

December 2019

Type 252 Filter

Introduction

Scope of the Manual

This manual provides instructions for installation, maintenance and parts information for the Type 252 filter.

Product Description

The Type 252 filter is designed to clean gas or air before it enters pilots on pilot operated regulators, pneumatic instruments or other devices that require clean mediums to operate properly. It prevents paint chips, dirt, pipe scale and some moisture from reaching the pilot or other equipment it is protecting.

To cover a wide variety of gas and air applications, the Type 252 filter is available in aluminum or stainless steel with a standard or extended length filter body. The difference between the standard and extended versions is the length of the body. The extended body has more storage capacity for moisture and debris removed from the air or gas.

The Type 252 filter has temperature capabilities from -40 to 180°F / -40 to 82°C. The aluminum filter has a working pressure of up to 2150 psig / 148 bar and the stainless steel filter has a working pressure of up to 2750 psig / 190 bar.

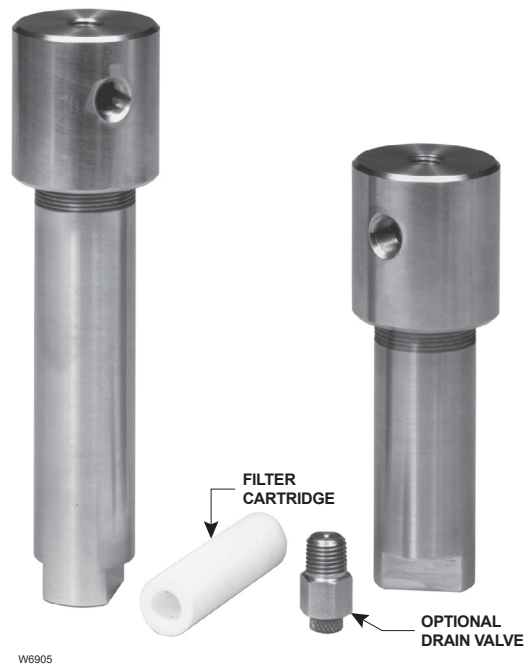

Figure 1. Type 252 Filters

If a leak develops in the system, the escaping gas may accumulate and become a fire or explosion hazard. Immediately call qualified service personnel in case of trouble.



WARNING

Installation, operation and maintenance procedures performed by unqualified personnel may result in unsafe operation. This condition may result in equipment damage or personal injury. Use qualified personnel when installing, operating and maintaining these filters.

Installation

Thoroughly clean and blow all pipelines to remove pipe scale and other foreign matter which accelerate the clogging of the filter.

When installing the filter, follow established piping practices. Apply a good grade of pipe compound to the male pipeline threads. Install the filter in the line with the flow as indicated by the in and out markings on the filter head.

Type 252

Specifications

The Specifications section on this page provides the ratings and other specifications for the Type 252. Factory specification such as type, maximum casing pressure and maximum temperature are stamped on the nameplate fastened on the filter at the factory.

Inlet and Outlet Connections Size NPS 1/4, NPT	Maximum Differential 100 psig / 6.9 bar
Maximum Working Pressure⁽¹⁾⁽²⁾ Aluminum: 2150 psig / 148 bar Stainless steel: 2750 psig / 190 bar	Approximate Weights Standard Body: <i>Aluminum:</i> 0.8 lb / 0.3 kg <i>Stainless steel:</i> 2.3 lbs / 1 kg
Maximum Temperature Capabilities⁽¹⁾ -40 to 180°F / -40 to 82°C	Extended Body: <i>Aluminum:</i> 1 lb / 0.4 kg <i>Stainless steel:</i> 3 lbs / 1.4 kg
Filter Rating 20 microns	

1. The pressure/temperature limits in this Instruction Manual and any applicable standard or code limitation should not be exceeded.
2. A pressure exceeding this value can cause failure of or leakage from, pressure-containing components.



WARNING

Personal injury, equipment damage or leakage due to escaping gas or bursting of pressure-containing parts may result if the filter is installed where its capabilities can be exceeded or where conditions exceed any ratings of the adjacent piping or piping connections. To avoid this, install a filter where:

- Service conditions are within unit capabilities.
- Service conditions are within applicable codes, regulations or standards. Physical damage to the filter could result in breakage, causing personal injury and property damage due to escaping gas. To avoid such injury or damage, install the unit in a safe location.

Maintenance

Filter parts are subject to normal wear and must be inspected periodically and replaced as necessary. The frequency of inspection and replacement depends upon the severity of service conditions and upon applicable codes and government regulations.

To ensure a tight seal, check the condition of the O-ring and lubricate it with Multi-Purpose

Polytetrafluoroethylene (PTFE) lubricant whenever opening the filter. When inspecting filters with the optional drain valves, make sure valves are free of any debris that may restrict the drain flow.

The upper seat is lightly pressed into the filter head. To replace the upper seat, it may be necessary to remove the 1/4 in. / 6.35 mm pipe plug and push the upper seat out of the filter head.



WARNING

Avoid personal injury or damage to property from sudden release of pressure or uncontrolled gas or other process fluid. Before starting disassembly, carefully release all pressures from the filter.

- Never loosen the filter body while the unit is underpressure.
- Do not remove any pipe plugs from the unit while it is underpressure.
- Use a gauge to monitor pressure while releasing it.
- The optional drain valve is for releasing fluid.
- Direct the flow stream in a safe direction.
- The filter head and filter body must be constructed from the same material to reduce galvanic corrosion.

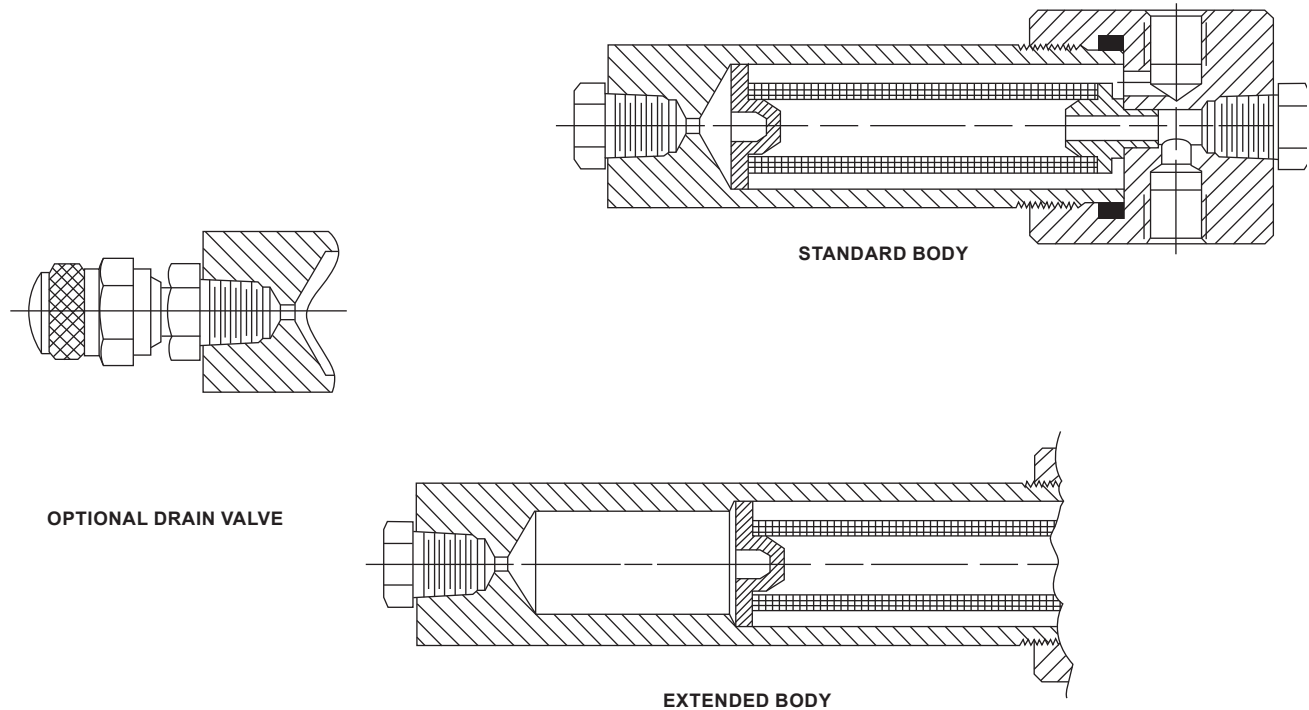

A7013

Figure 2. Type 252 Filter

To Replace Type 252 Filter Cartridge

1. Close the upstream and downstream shutoff valves.
2. Bleed off the pressure.
3. Open the drain valve and drain the moisture from the filter body.
4. Unscrew the filter body from the filter head. Inspect the O-ring and replace if damaged.
5. Remove the filter cartridge. Install the new filter element.
6. Lubricate the O-ring with Multi-Purpose PTFE lubricant and reassemble the filter.

Universal NACE Compliance

Optional materials are available for applications handling sour gases. These constructions comply with the recommendations of NACE International sour service standards.

The manufacturing processes and materials used by Emerson Process Management Regulator Technologies, Inc. assure that all products specified for sour gas service comply with the chemical, physical and metallurgical requirements of NACE MR0175 and/or NACE MR0103. Customers have the responsibility to specify correct materials. Environmental limitations may apply and shall be determined by the user.

Parts Ordering

When corresponding with your local Sales Office about this filter, always reference the FS number.

When ordering replacement parts, specify the complete 11-character part number from the following parts list.

Type 252

Parts List

Key	Description	Part Number	Key	Description	Part Number
	Parts Kit (Included are keys 3, 4, 5 and 8)	R252X000012	4*	Filter Cartridge, Polyethylene	17B6813X012
2	Filter Body		5*	O-ring, Nitrile (NBR)	1F269206992
	Aluminum		6	Pipe Plug, 316 Stainless steel	1A767535072
	Standard	-----	7	Drain Valve (Optional),	
	Extended	-----		316 Stainless steel	18B0909X012
	316 Stainless steel		8*	Upper Seat, Delrin®	17B6814X012
	Standard	-----	9	Filter Head	
	Extended	-----		Aluminum	-----
3*	Lower Seat, Delrin®	17B6816X012		316 Stainless steel	-----

*Recommended Spare Part
Delrin® is a mark owned by E.I. du Pont de Nemours and Co.

 Webadmin.Regulators@emerson.com

 [Facebook.com/EmersonAutomationSolutions](https://www.facebook.com/EmersonAutomationSolutions)

 Fisher.com

 [LinkedIn.com/company/emerson-automation-solutions](https://www.linkedin.com/company/emerson-automation-solutions)

 [Twitter.com/emr_automation](https://twitter.com/emr_automation)

Emerson Automation Solutions

Americas

McKinney, Texas 75070 USA
T +1 800 558 5853
+1 972 548 3574

Europe

Bologna 40013, Italy
T +39 051 419 0611

Asia Pacific

Singapore 128461, Singapore
T +65 6777 8211

Middle East and Africa

Dubai, United Arab Emirates
T +971 4 811 8100

D102465X012 © 1997, 2019 Emerson Process Management Regulator Technologies, Inc. All rights reserved. 12/19.
The Emerson logo is a trademark and service mark of Emerson Electric Co. All other marks are the property of their prospective owners. Fisher™ is a mark owned by Fisher Controls International LLC, a business of Emerson Automation Solutions.

The contents of this publication are presented for informational purposes only, and while every effort has been made to ensure their accuracy, they are not to be construed as warranties or guarantees, express or implied, regarding the products or services described herein or their use or applicability. All sales are governed by our terms and conditions, which are available upon request. We reserve the right to modify or improve the designs or specifications of such products at any time without notice.

Emerson Process Management Regulator Technologies, Inc. does not assume responsibility for the selection, use or maintenance of any product. Responsibility for proper selection, use and maintenance of any Emerson Process Management Regulator Technologies, Inc. product remains solely with the purchaser.

