

# Agilent 7890 Series Gas Chromatograph

## Maintaining Your GC



# Notices

© Agilent Technologies, Inc. 2014

No part of this manual may be reproduced in any form or by any means (including electronic storage and retrieval or translation into a foreign language) without prior agreement and written consent from Agilent Technologies, Inc. as governed by United States and international copyright laws.

## Manual Part Number

G3430-90052

## Edition

Third edition, September 2014  
Second edition, December 2013  
First edition, January 2013

Printed in USA

Agilent Technologies, Inc.  
2850 Centerville Road  
Wilmington, DE 19808-1610 USA

安捷伦科技（上海）有限公司  
上海市浦东新区外高桥保税区  
英伦路 412 号  
联系电话：（800）820 3278

## Warranty

**The material contained in this document is provided “as is,” and is subject to being changed, without notice, in future editions. Further, to the maximum extent permitted by applicable law, Agilent disclaims all warranties, either express or implied, with regard to this manual and any information contained herein, including but not limited to the implied warranties of merchantability and fitness for a particular purpose. Agilent shall not be liable for errors or for incidental or consequential damages in connection with the furnishing, use, or performance of this document or of any information contained herein. Should Agilent and the user have a separate written agreement with warranty terms covering the material in this document that conflict with these terms, the warranty terms in the separate agreement shall control.**

## Safety Notices

### CAUTION

A **CAUTION** notice denotes a hazard. It calls attention to an operating procedure, practice, or the like that, if not correctly performed or adhered to, could result in damage to the product or loss of important data. Do not proceed beyond a **CAUTION** notice until the indicated conditions are fully understood and met.

### WARNING

A **WARNING** notice denotes a hazard. It calls attention to an operating procedure, practice, or the like that, if not correctly performed or adhered to, could result in personal injury or death. Do not proceed beyond a **WARNING** notice until the indicated conditions are fully understood and met.

# Contents

## 1 About Maintaining the GC

- Overview of Maintenance 10
- Tools and Materials Required for Maintenance 11
- Maintenance Methods for the 7890 Series GC 13
- Safety Information 15
- Finding a Replacement Part Number 16

## 2 Removing Covers

- To Remove the Detector Top Cover 18
- To Remove the Pneumatics Cover 19
- To Remove the Electronics Cover 20

## 3 Maintaining the GC

- Consumables and Parts for General GC Maintenance 22
- Parts Identification 24
- To Change the Hydrogen Sensor Calibration Gas Cylinder 25
- Using the removable oven door 27

## 4 Maintaining Capillary Columns

- Consumables and Parts for Columns 30
- To Install a Capillary Column Hanger 32
- To Install Capillary Column Clips 33
- To Condition a Capillary Column 34
- To Cut a Loop from a Column 37
- To Reverse a Column and Bakeout Contaminants 38
- To Attach a Capillary Column Using SilTite Metal Fittings 40
- To Disconnect Fused Silica Tubing From a SilTite Fitting 42

## 5 Maintaining the Split/Splitless Inlet

- Consumables and Parts for the Split/Splitless Inlet 44
- Exploded Parts View of the Split/Splitless Inlet 47
- To Install a Capillary Column with the Split/Splitless Inlet 48
- To Change the Septum on the Split/Splitless Inlet 52

To Clean the Septum Seat in the Insert Assembly of the Split/Splitless Inlet	54
To Change the Liner and O-Ring on the Split/Splitless Inlet	56
To Replace the Gold Seal on the Split/Splitless Inlet	59
To Replace the Filter in the Split Vent Line for the Split/Splitless Inlet	61
To Clean the Split/Splitless Inlet	64
To Bakeout Contaminants from the Split/Splitless Inlet	66

## **6 Maintaining the Purged Packed Inlet**

Consumables and Parts for the Purged Packed Inlet	68
Exploded Parts View of the Purged Packed Inlet	71
To Install a Capillary Column with the Purged Packed Inlet	72
To Change the Septum on the Purged Packed Inlet	77
To Clean the Septum Seat in the Purged Packed Inlet	79
To Install an Adapter on the Purged Packed Inlet	81
To Change the O-Ring on the Purged Packed Inlet	83
To Change the Glass Liner on the Purged Packed Inlet	84
To Install an Insulation Cup on the Purged Packed Inlet	86
To Clean the Purged Packed Inlet	87
To Bakeout Contaminants from the Purged Packed Inlet	89
To Install a Packed Metal Column	90
To Install a Packed Column Adapter on a Detector Fitting	92
To Install a Packed Glass Column	94
To Condition a Packed Column	97
To Install Ferrules on a Packed Metal Column	99

## **7 Maintaining the COC Inlet**

Consumables and Parts for the COC Inlet	102
Exploded Parts View of the COC Inlet	106
To Install a Capillary Column with the COC Inlet	107
To Check the Needle-to-Column Size on the COC Inlet	110
To Change a Septum on the COC Inlet	112
To Install an Insert on the COC Inlet	114
To Clean the COC Inlet	116

- To Replace the 7693A Injector Needle Support Guide 118
- To Replace the Needle Support Assembly in a 7683B Injector 119
- To Replace a Needle in a Syringe 122
- To Replace the Fused Silica Needle in a Syringe for the COC Inlet 123
- To Bakeout Contaminants from the COC Inlet 125

## 8 Maintaining the MMI

- Consumables and Parts for the MMI 128
- Exploded Parts View of the MMI 131
- To Install the Column Nut Adapter 132
- To Install a Capillary Column with the MMI 133
- To Change the Septum on the MMI 137
- To Clean the Septum Seat in the Insert Assembly of the MMI 139
- To Change the Liner and O-Ring on the MMI 141
- To Replace the Filter in the Split Vent Line for the MMI 144
- To Clean the Multimode Inlet 147
- To Bakeout Contaminants from the MMI 149

## 9 Maintaining the PTV Inlet

- Consumables and Parts for the PTV Inlet 152
- Exploded Parts View of the PTV Inlet 154
- To Install a Capillary Column with the PTV Inlet 155
- To Clean the Septumless Head on the PTV Inlet 158
- To Replace the Septumless Head PTFE Ferrule on the PTV Inlet 161
- To Change the Septum on the PTV Inlet 163
- To Clean the Septum Seat in the Septum Head Assembly of the PTV Inlet 165
- To Change the Liner on the PTV Inlet 167
- To Replace the Inlet Adapter for the PTV Inlet 170
- To Replace the Filter in the Split Vent Line for the PTV Inlet 172
- To Bakeout Contaminants from the PTV Inlet 175

## 10 Maintaining the VI

- Consumables and Parts for the VI 178
- Exploded Parts View of the VI 180

- To Install a Capillary Column with the VI [181](#)
- To Remove the VI Interface [185](#)
- To Clean the VI [187](#)
- To Install the VI Interface [189](#)
- To Replace the Filter in the Split Vent Line for the VI [190](#)
- To Bakeout Contaminants from the VI Inlet [193](#)

## **11 Maintaining the FID**

- Consumables and Parts for the FID [196](#)
- Exploded Parts Views of the FID [199](#)
- Selecting an FID Jet [201](#)
- To Attach a Capillary Column Adapter on an Adaptable FID [203](#)
- To Install a Capillary Column in the FID [205](#)
- To Replace the FID Collector Assembly [209](#)
- To Replace an FID Jet [212](#)
- To Perform Maintenance on the FID Collector Assembly [216](#)
- To Check the FID Leakage Current [224](#)
- To Check the FID Baseline [225](#)
- To Install the FID Insulation Cup Assembly (Adaptable FID Only) [226](#)
- To Install the Optional FID PTFE Chimney Insert [228](#)
- To Bakeout the FID [229](#)

## **12 Maintaining the TCD**

- Consumables and Parts for the TCD [232](#)
- To Install a Capillary Column in the TCD [234](#)
- To Install the Optional TCD Capillary Column Adapter [236](#)
- To Install a Capillary Column with the Optional TCD Capillary Column Adapter [237](#)
- To Bakeout Contaminants from the TCD [240](#)

## **13 Maintaining the uECD**

- Important Safety Information About the uECD [242](#)
- Consumables and Parts for the uECD [244](#)
- Exploded Parts View of the uECD [246](#)

- To Replace the uECD Fused Silica Indented Mixing Liner and Install the Makeup Gas Adapter 247
- To Install a Capillary Column in the uECD 251
- To Install the Insulating Cup for the uECD 254
- To Bakeout the uECD 256

## 14 Maintaining the NPD

- Consumables and Parts for the NPD 260
- Exploded Parts View of the NPD 263
- Selecting an NPD Jet 264
- To Attach a Capillary Column Adapter on an Adaptable NPD 266
- To Install a Capillary Column in the NPD 268
- To Replace the NPD Bead Assembly 272
- To Maintain the NPD Collector, Ceramic Insulators, and Jet 279
- To Check the NPD Leakage Current 285
- To Bakeout the NPD 286

## 15 Maintaining the FPD<sup>+</sup>

- Consumables and Parts for the FPD<sup>+</sup> 290
- Exploded Parts View of the FPD<sup>+</sup> 292
- To Install a Packed Column Adapter in the FPD<sup>+</sup> 293
- To Attach a Capillary Column to the FPD<sup>+</sup> 295
- To Change the FPD<sup>+</sup> Wavelength Filter 297
- To Remove the FPD<sup>+</sup> Cover 300
- To Replace the FPD<sup>+</sup> Ignitor 302
- To Install the FPD<sup>+</sup> Cover 304
- Cleaning the FPD<sup>+</sup> Brazement 305

## 16 Maintaining the G3435A/G3436A FPD

- Consumables and Parts for the FPD 308
- Exploded Parts View of the FPD 310
- To Install a Capillary Column Adapter in the FPD 311
- To Attach a Capillary Column to the FPD 313
- To Change the FPD Wavelength Filter 315
- To Remove the FPD Vent Tube 318

- To Replace the FPD Ignitor 320
- To Install the FPD Vent Tube and Cover 322

## **17 Maintaining the Aux EPC**

- Consumables and Parts for the Aux EPC 324
- Installing or Replacing Frits in the Aux EPC 326

## **18 Maintaining the PCM**

- Consumables and Parts for the PCM 330
- Calibrating the PCM Interface 331
- Installing or Replacing Frits in the PCM 332

## **19 Maintaining a Valve**

- Consumables and Parts for Valves 336
- Exploded Parts View of GC Rotary Valves 337
- To Replace a Gas Sampling Valve Loop 338
- To Align a Rotary Valve Rotor 340
- To Replace a Rotary Valve in the Valve Box 341
- To Remove the Upper Valve Box 344
- To Install the Upper Valve Box 346

## **20 Swagelok Connections**

- Making Swagelok Connections 350
- Using a Swagelok Tee 354



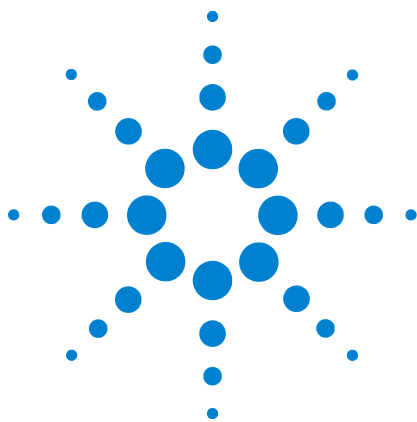

# 1 About Maintaining the GC

Overview of Maintenance	10
Tools and Materials Required for Maintenance	11
Maintenance Methods for the 7890 Series GC	13
Safety Information	15
Finding a Replacement Part Number	16

This section provides an overview of the maintenance procedures included in this document. It also lists the tools needed for routine maintenance and the safety information one should be aware of before performing a maintenance task.



## Overview of Maintenance

This manual details the routine tasks needed to maintain the 7890 Series Gas Chromatograph (GC). The procedures assume a basic knowledge of tool use and of GC operation. Readers are, for example, expected to know how to:

- Safely turn devices on and off
- Load methods
- Change component temperatures, flows, and pressures
- Make typical pneumatic connections using Swagelok and other standard fittings
- Reset GC service counters

### Where to find a procedure

Included in this manual are chapters on maintaining the following GC components:

- Capillary Columns
- Split/Splitless Inlet
- Purged Packed Inlet
- COC Inlet
- Multimode Inlet
- PTV Inlet
- Volatiles Inlet (VI)
- FID
- TCD
- uECD
- NPD
- FPD<sup>+</sup>
- FPD
- Auxiliary EPC
- PCM
- Valves

Each chapter includes:

- A list of the most commonly used consumables and parts for the component
- An exploded parts view of the component
- Detailed procedures for routine maintenance tasks associated with the component

## Tools and Materials Required for Maintenance

**Table 1** lists the tools needed for most GC maintenance procedures. The specific tools required to perform a maintenance procedure are listed in step 1 of the procedure.

**Table 1** Tools and materials for GC maintenance

<b>Common tools</b>
Wrench, angled, septum nut (19251-00100)
Wrench, open-end, 1/4-inch and 5/16-inch (8710-0510)*
Wrench, open-end, 9/16-inch and 7/16-inch (8710-0803)
Wrench, capillary inlet ( G3452-20512 )*
Flathead screwdriver
Column cutter, wafer (5181-8836, 4/pk)*
Driver, nut, 1/4-inch (8710-1561)*
T-20 Torx key (8710-1807) or screwdriver
T-10 Torx key (8710-2140) or screwdriver
3-mm hex key wrench (8710-2411)
Electronic flow meter(s) or bubble meter(s) capable of calibrated measurements at 1, 10, and 100 mL/min flow ranges.
Electronic leak detector
Magnifying loupe, 20X (430-1020)
Metric ruler
Bench vise (for setting Swagelok fittings)
Razor or sharp knife
Tweezers (8710-0007) or thin needle-nose pliers (8710-0004)
Needle-nose pliers
ESD wrist strap (for installing new components)
Gloves, heat-resistant (for handling hot parts)
Wooden cotton swab (for removing FID filters)
<b>Tools and materials for cleaning procedures</b>
Cleaning brushes—The FID cleaning kit (9301-0985) contains appropriate brushes for cleaning detectors and inlets
Cleaning brushes—(8710-1346) For cleaning split/splitless inlet split vent fitting, FID and collectors

**Table 1** Tools and materials for GC maintenance (continued)

---

Jet cleaning wire (.010 inch)

---

Clean, lint-free cloth (to protect contamination-sensitive detector parts)

---

Small ultrasonic cleaning bath with aqueous detergent (for cleaning detector and inlet parts)

---

Gloves, clean, lint-free, nylon (large: 8650-0030, small: 8650-0029) (for handling contamination-sensitive parts)

---

Steel wool, 0- or 00-grade (for cleaning an inlet's septum seating surfaces)

---

\* Included with the GC ship kits

## Maintenance Methods for the 7890 Series GC

Before most maintenance procedures, the GC must be made ready. Agilent recommends that you create and store the following maintenance methods into the GC. The methods below will:

- Prevent damage to the instrument (electronics, columns, etc.)
- Avoid injury to the user (burns, shocks, etc.)
- Allow you to perform maintenance on specific areas while leaving the rest of the GC components at operating temperature

### NOTE

Inlets and detectors at operating temperature may require 12 hours or longer to reach the maintenance method setpoints below.

For information regarding programming, saving, and loading methods, refer to the [7890 Series Advanced User Guide](#) or your data system help.

### General GC Maintenance Method

Create this method for instrument column maintenance, detector maintenance, and general GC maintenance tasks.

- Set the oven temperature to **35 °C**. This allows the oven fan to assist cooling.
- Set all inlet temperatures to **35 °C** and set inlet gas pressures to **0.0**.
  - If performing column maintenance, remember to wait for the oven and column to cool down before turning off column carrier gas flow at the source. Also remember to cap both ends of the column to keep air out once it is removed.
  - If you are not performing column maintenance, keep inert carrier gas (helium or nitrogen) flowing to protect the column.
- Set all detector temperatures to **35 °C**.
  - If performing FPD maintenance, turn off the GC and unplug the power cord.
  - Some detectors (FID, NPD) use high voltages. For these detectors, turn the electrometer **Off** to disable the high voltage.

- The filament in the TCD will be damaged if exposed to air while hot. To protect the filament, turn it **Off**.
- Set all detector flows to **Off**.

Once the zones reach  $< 70$  °C, you can perform general GC maintenance.

### **WARNING**

**Be careful! The oven, inlet, and/or detector may be hot enough to cause burns. If the oven, inlet, or detector is hot, wear heat-resistant gloves to protect your hands.**

---

## Inlet Maintenance Method

This method prepares the inlet for maintenance while leaving the detector at operating temperature.

- Set the oven temperature to **35 °C**. This allows the oven fan to assist cooling.
- Set all inlet temperatures to **Off** and set inlet gas pressures to **0.0**.
  - If performing column maintenance, remember to wait for the oven and column to cool down before turning off column carrier gas flow at the source. Also remember to cap both ends of the column to keep air out once it is removed.
  - If you are not performing column maintenance, keep inert carrier gas (helium or nitrogen) flowing to protect the column.
- Maintain all temperature setpoints for installed detectors, if desired.
  - The filament in the TCD will be damaged if exposed to air while hot. To protect the filament, turn it **Off**.

Once the zones reach  $< 70$  °C, you can perform general GC maintenance.

### **WARNING**

**Be careful! The oven, inlet, and/or detector may be hot enough to cause burns. If the oven, inlet, or detector is hot, wear heat-resistant gloves to protect your hands.**

---

## Safety Information

Before performing a maintenance task, read the important safety and regulatory information found in the [7890 Series Safety and Regulatory Information](#) book.

## Finding a Replacement Part Number

Agilent now provides the Parts Finder tool to help you locate replacement and consumable part numbers. If using an Agilent data system, Parts Finder will be installed. If you want to install the tool on another computer, Parts Finder is included on the Agilent *GC and GC/MS User Manuals & Tools DVD*.

To find a consumable or replacement part using Parts Finder, navigate to the part graphically, based on the part's location in the GC.

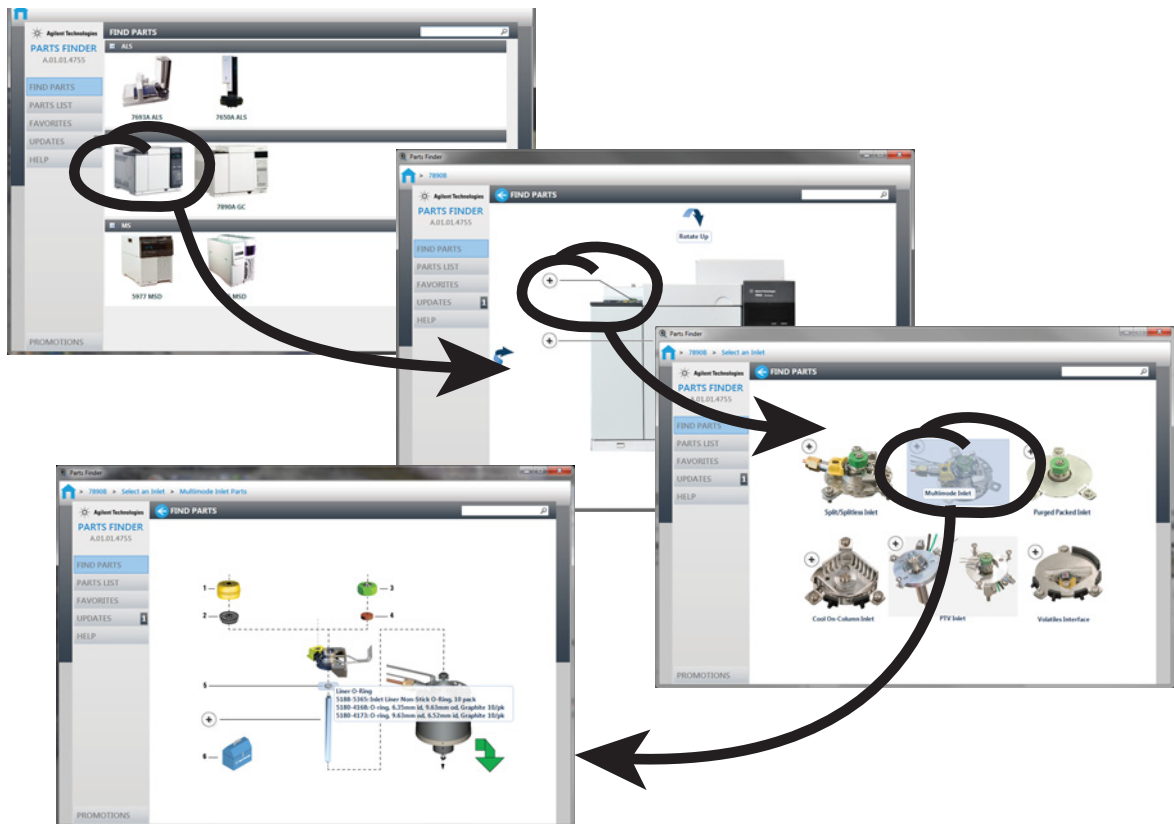

**Figure 1** Quickly navigate to replacement parts by clicking on images of GC components

Part numbers are also included in this manual.



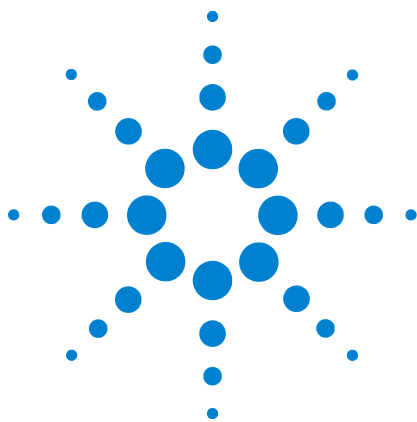

## 2 Removing Covers

- To Remove the Detector Top Cover 18
- To Remove the Pneumatics Cover 19
- To Remove the Electronics Cover 20

This section describes how to remove covers as needed for routine maintenance.

Only the covers listed in this chapter should be removed. Removing other GC covers can compromise the safety features of the GC, leading to personal injury or damage to the instrument.



## To Remove the Detector Top Cover

This cover protects the detectors, valve box, and valve assembly. To remove the detector top cover:

- 1 Raise it to a vertical position
- 2 Lift the right side and disengage the pin on the lower left side.

**CAUTION**

Do not force the cover, either when installing it or closing it. This could break the plastic parts.

---

To replace the cover, make certain that the slot in the bushing (lower right corner) is vertical and that the bushing is fully seated. Installation is then the reverse of removal.

## To Remove the Pneumatics Cover

The pneumatics cover protects the flow manifolds in the back top of the GC.

- 1 Disconnect any vent tubing connected to the split and septum purge vents.
- 2 Two large buttons on each side of the GC secure the cover to the detector frame. Press both buttons and lift the cover off.

## To Remove the Electronics Cover

You may need to raise the electronics cover to perform NPD maintenance. The steps required depend on whether or not an FPD is installed.

**CAUTION**

Raising the electronics cover exposes the GC electronics.

---

Without FPD installed:

- 1 Raise or remove the detector top cover.
- 2 Loosen the screw on the left side of the electronics cover.
- 3 Raise the cover to the vertical position.

With FPD installed:

- 1 Raise or remove the detector top cover.
- 2 Loosen the screw on the left side of the electronics cover.
- 3 Loosen the two thumbscrews in the tray below the PMT, and remove the two screws in the back of the tray.

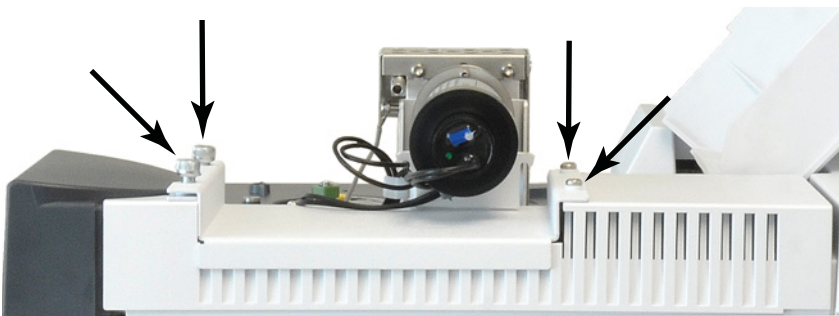

- 4 Remove the tray from the electronics cover.
- 5 Raise the cover to the vertical position.

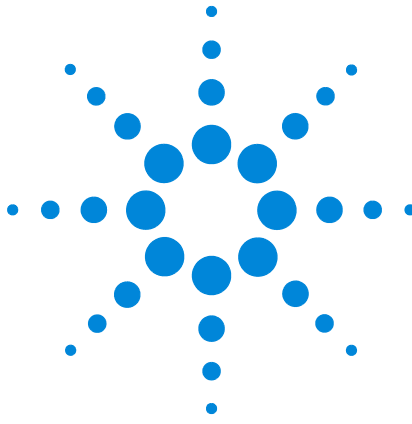

### 3 Maintaining the GC

Consumables and Parts for General GC Maintenance	22
Parts Identification	24
To Change the Hydrogen Sensor Calibration Gas Cylinder	25
Using the removable oven door	27

## Consumables and Parts for General GC Maintenance

Table 2 lists consumable parts for the hydrogen sensor module accessory and for general GC maintenance.

**Table 2** G3447A Hydrogen Sensor Module Accessory parts

Description	Part number
<b>Hydrogen sensor parts</b>	
Calibration gas cylinder, 2 percent hydrogen gas in 17 L compressed air	5190-6890
Cylinder stand with locking screw	1400-3583
Pressure regulator, with gage	G3440-80153
<b>Fittings and hardware</b>	
Fittings kit, 1/8-in. brass, 20/pk	5080-8750
Plug, 1/8-in. brass 6/pk	5180-4124
Tee, 1/8-in. brass 2/pk	5180-4160
Union, 1/8-in. brass 2/pk	5180-4127
Cross, union 1/8-in. brass	0100-0161
GC Supply Gas Installation Kit with Gas Purifiers	19199N
Installation kit for GCs without gas purifiers	19199M
PTFE tape	0460-1266
Copper tubing, 1/8-in. 12 ft.	5021-7107
Copper tubing, 1/8-in. od, 50 ft	5180-4196
<b>Gas regulators</b>	
Regulator, 2-stage, brass body, stainless steel diaphragms, 125 psi max, CGA350, hydrogen, argon/methane, with 1/8-in. fitting. For 1/4-in. tubing purchase a 1/4-in. adapter.	5183-4642
Regulator, 2-stage, brass body, stainless steel diaphragms, 125 psi max, CGA346, air, with 1/8-in. fitting. For 1/4-in. tubing purchase a 1/4-in. adapter.	5183-4641
Regulator, 2-stage, brass body, stainless steel diaphragms, 125 psi max, CGA590, industrial air, with 1/8-in. fitting. For 1/4-in. tubing purchase a 1/4-in. adapter.	5183-4645
Regulator, 2-stage, brass body, stainless steel diaphragms, 125 psi max, CGA580, helium, argon, nitrogen, 1/8-in. fitting. For 1/4-in. tubing purchase a 1/4-in. adapter.	5183-4644
Regulator, 2-stage, brass body, stainless steel diaphragms, 125 psi max, CGA540, oxygen, 1/8-in. fitting. For 1/4-in. tubing purchase a 1/4-in. adapter.	5183-4643
<b>Gas Clean Filters</b>	
Gas Clean connecting unit, 1-position), 1/4-in.	CP7980
Gas Clean connecting unit, 1-position), 1/8-in.	CP7988
Gas Clean connecting unit, 2-position), 1/4-in.	CP738406
Gas Clean connecting unit, 2-position), 1/8-in.	CP738407
Connect unit, Gas Clean, 4 filter, 1/4-in., 1/pk	CP7989

**Table 2** G3447A Hydrogen Sensor Module Accessory parts

<b>Description</b>	<b>Part number</b>
Gas Clean connecting unit, 4-position), 1/8-in. fittings	CP736520
Gas Clean high-flow connecting unit, 2-position), with 1/4-in. fittings, for high-flow applications such as ICP-MS or ICP-OES	CP17984
High flow connecting unit 1/8-in.	CP17985
Gas Clean filter GC-MS, 1/pk	CP17973
Gas Clean filter oxygen, 1/pk	CP17970
Gas Clean filter moisture, 1/pk	CP17971
Gas Clean filter charcoal, 1/pk	CP17972
Gas Clean filter kit for TCD	CP738408
Gas Clean filter starter kit for FID	CP7995
Gas Clean filter starter kit for FID	CP736530
Gas Clean filter kit for GC/MS	CP17976
Gas Clean filter kit for GC/MS	CP17977
Gas Clean filter install kit GC-MS, 1/pk	CP17978
Flush head, Gas Clean connecting unit, used to purge gas lines after installing connecting unit	CP7987
Gas Clean wall-mounting bracket for 1-position) connecting unit only	CP7981

For additional general and filters, refer to the Agilent web site and Parts Finder software. For additional information about choosing the correct gas line filters, see the *GC, GC/MS, and ALS Site Preparation Guide* and visit the Agilent web site.

## Parts Identification

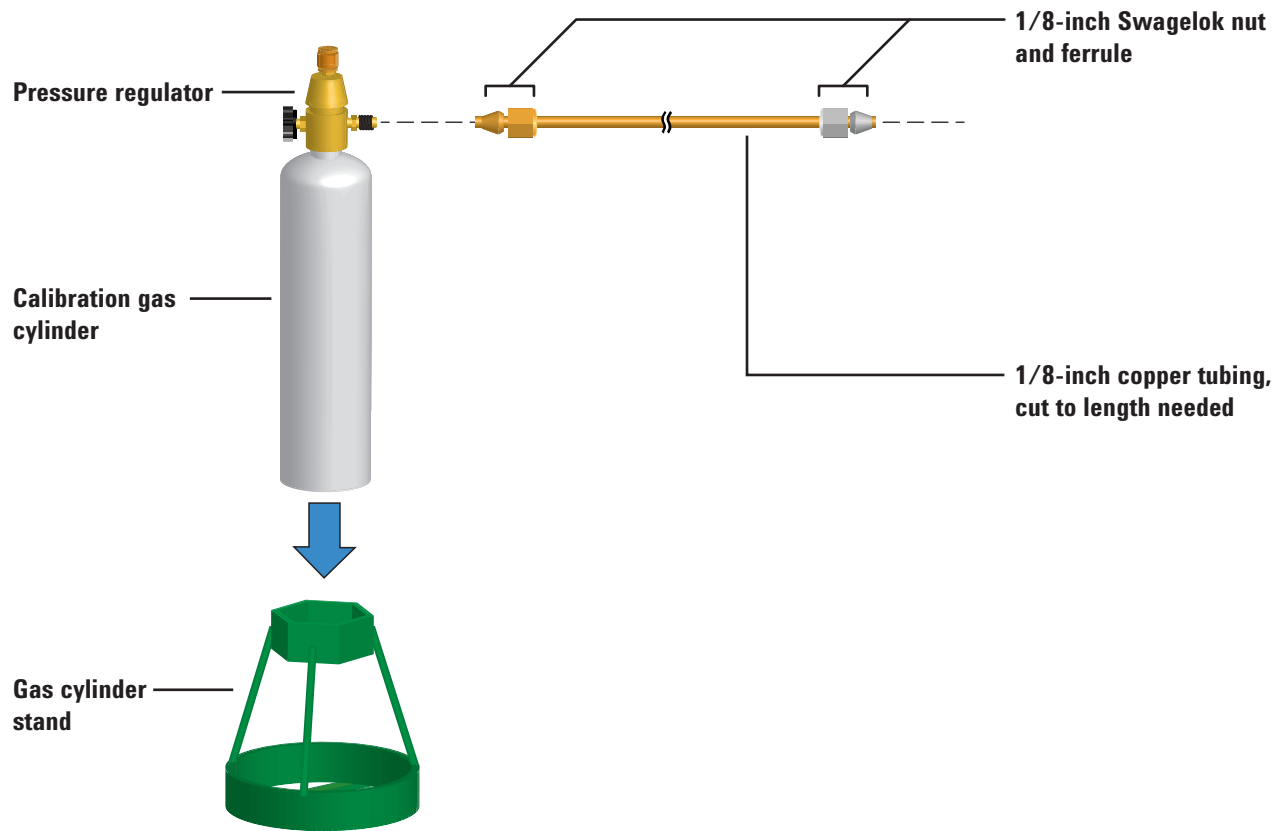



## To Change the Hydrogen Sensor Calibration Gas Cylinder

Replace the calibration gas cylinder when you cannot adjust it to provide the correct flow rate during calibration, or if it expires.

### WARNING

**Connect only the Agilent calibration gas to the hydrogen sensor fitting. The calibration gas is 2% hydrogen in air and is not potentially explosive. Gases with higher concentrations of hydrogen can create a dangerous condition in the oven or damage the hydrogen sensor.**

- 1 Make sure the old cylinder is empty.
- 2 Turn the pressure regulator completely off and set the output pressure as low as possible (full CCW).
- 3 Remove the pressure regulator from the old cylinder and install it onto the new cylinder.
- 4 Install the new cylinder into the stand.
- 5 Turn on the pressure in the new cylinder.
- 6 Open the GC oven door and connect a flowmeter tube to the sensor tube in the oven.

Connect the flow meter to the hydrogen sensor tube next to the oven heater shroud

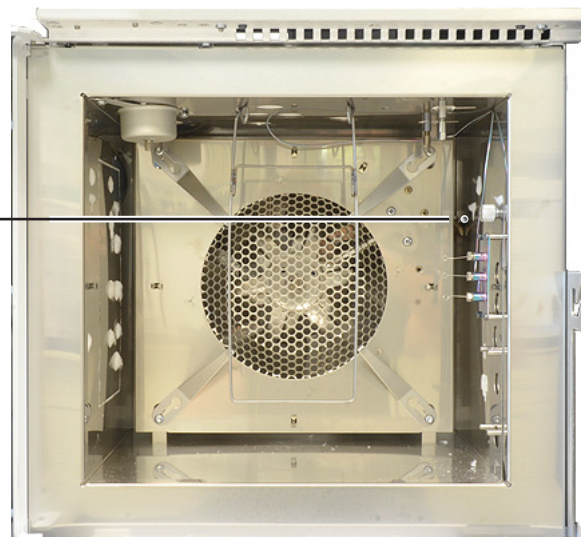

- 7 Press **[Options]** then go to **Calibration > Hydrogen Sensor** and press **[Enter]**.
- 8 Scroll to **Start Calibration Cycle?** and press **[On/Yes]**. The calibration cycle begins. The hydrogen sensor module will wait to stabilize, then will begin to send calibration gas across the sensor.

### **3 Maintaining the GC**

- 9** While continuing to measure the flow rate from the tube, adjust the pressure regulator on the calibration gas cylinder until the flow rate is approximately 30 mL/min. Remove the flowmeter and close the oven door.
- 10** Allow the calibration cycle to complete (approximately 5 minutes total).
- 11** Check for leaks.

## Using the removable oven door

All LVO GCs ship with a removable oven door that allows easier access to the oven.

### WARNING

**To prevent personal injury, when removing the door, take care to adequately support the door using both hands or a second person. Failure to properly support the door could cause it to fall.**

To remove the oven door:

- 1 Cool the GC oven to ambient temperature.
- 2 Open the oven door, then turn the top hinge lever to unlock it. See [Figure 2](#).



**Figure 2** Removing the oven door

- 3 Pull the top hinge lever down and tilt the top of the door out to release the top pin from the hinge.
- 4 Using both hands, carefully lift off the oven door from the lower oven door pin and remove the door from the GC.

To install the oven door:

- 1 Using both hands, carefully place the oven door onto the lower door pin.
- 2 Tilt the door up and under the upper hinge, then engage the top pin into the hinge.
- 3 Lock the lever.

### **3 Maintaining the GC**

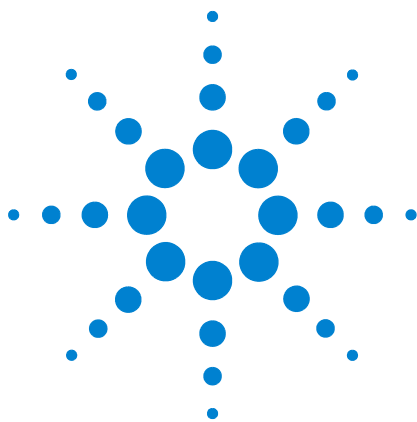

## 4 Maintaining Capillary Columns

Consumables and Parts for Columns	30
To Install a Capillary Column Hanger	32
To Install Capillary Column Clips	33
To Condition a Capillary Column	34
To Cut a Loop from a Column	37
To Reverse a Column and Bakeout Contaminants	38
To Attach a Capillary Column Using SilTite Metal Fittings	40
To Disconnect Fused Silica Tubing From a SilTite Fitting	42



## Consumables and Parts for Columns

See the Agilent catalog for consumables and supplies for a more complete listing, or visit the Agilent Web site for the latest information ([www.agilent.com/chem/supplies](http://www.agilent.com/chem/supplies)).

**Table 3** Nuts, ferrules, and hardware for capillary columns

Column id (mm)	Description	Typical use	Part number/quantity
.530	Ferrule, Vespel/graphite, 0.8-mm id	0.45-mm and 0.53-mm capillary columns	5062-3512 (10/pk)
	Ferrule, graphite, 1.0-mm id	0.53-mm capillary columns	5080-8773 (10/pk)
	Ferrule, graphite, 0.8-mm id	0.53-mm capillary columns	500-2118 (10/pk)
	Column nut, finger-tight (for 0.53-mm columns)	Connect column to inlet or detector	5020-8293
.320	Ferrule, Vespel/graphite, 0.5-mm id	0.32-mm capillary columns	5062-3514 (10/pk)
	Ferrule, graphite, 0.5-mm id	0.1-mm, 0.2-mm, 0.25-mm, and 0.32-mm capillary columns	5080-8853 (10/pk)
	Column nut, finger-tight (for .100- to .320-mm columns)	Connect column to inlet or detector	5020-8292
.250	Ferrule, Vespel/graphite, 0.4-mm id	0.1-mm, 0.2-mm, and 0.25-mm capillary columns	5181-3323 (10/pk)
	Ferrule, graphite, 0.5-mm id	0.1-mm, 0.2-mm, 0.25-mm, and 0.32-mm capillary columns	5080-8853 (10/pk)
	Column nut, finger-tight (for .100- to .320-mm columns)	Connect column to inlet or detector	5020-8292
.100 and .200	Ferrule, Vespel/graphite, 0.37-mm id	0.1-mm and 0.2-mm capillary columns	5062-3516 (10/pk)
	Ferrule, Vespel/graphite, 0.4-mm id	0.1-mm, 0.2-mm, and 0.25-mm capillary columns	5181-3323 (10/pk)
	Ferrule, graphite, 0.5-mm id	0.1-mm, 0.2-mm, 0.25-mm, and 0.32-mm capillary columns	5080-8853 (10/pk)
	Ferrule, graphite, 0.4-mm id		500-2114 (10/pk)
	Column nut, finger-tight (for .100- to .320-mm columns)	Connect column to inlet or detector	5020-8292
All	Ferrule, no-hole	Testing	5181-3308 (10/pk)
	Capillary column blanking nut	Testing—use with any ferrule	5020-8294
	Column nut, universal	Connect column to inlet or detector	5181-8830 (2/pk)

**Table 3** Nuts, ferrules, and hardware for capillary columns (continued)

<b>Column id (mm)</b>	<b>Description</b>	<b>Typical use</b>	<b>Part number/quantity</b>
	Column cutter, ceramic wafer	Cutting capillary columns	5181-8836 (4/pk)
	Pencil, diamond tipped	Cutting capillary columns	420-1000
	Ferrule tool kit	Ferrule installation	440-1000

**Table 4** Capillary column hangers

<b>Description</b>	<b>Part Number</b>
Column hanger	1460-1914
Capillary column clip kit, for 7-inch column basket	G1530-61580

## To Install a Capillary Column Hanger

**WARNING**

Be careful! The oven may be hot enough to cause burns. If the oven is hot, wear heat-resistant gloves to protect your hands.

---

**WARNING**

Wear safety glasses to protect your eyes from flying particles while handling, cutting, or installing glass or fused silica capillary columns. Use care in handling these columns to prevent puncture wounds.

---

- 1 Select either the front or back hanger position. (Hanger is shown in back position.)

Front position  
Back position

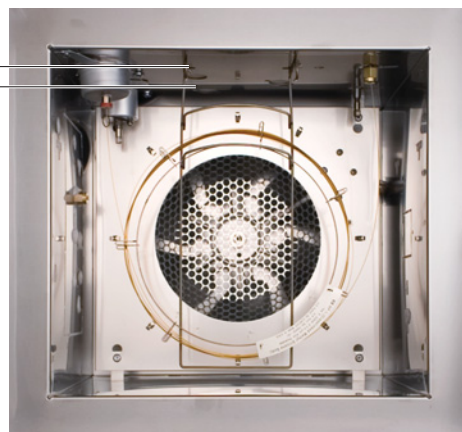

- 2 Insert the ends of the hanger into the slots in the selected position.



## To Install Capillary Column Clips

**WARNING**

Be careful! The oven may be hot enough to cause burns. If the oven is hot, wear heat-resistant gloves to protect your hands.

---

**WARNING**

Wear safety glasses to protect your eyes from flying particles while handling, cutting, or installing glass or fused silica capillary columns. Use care in handling these columns to prevent puncture wounds.

---

- 1 Gather the following:
  - Capillary column clip kit (see [“Consumables and Parts for Columns”](#) on page 30.)
  - T-20 Torx screwdriver
- 2 Loosen the four corner mounting screws, but do not remove.

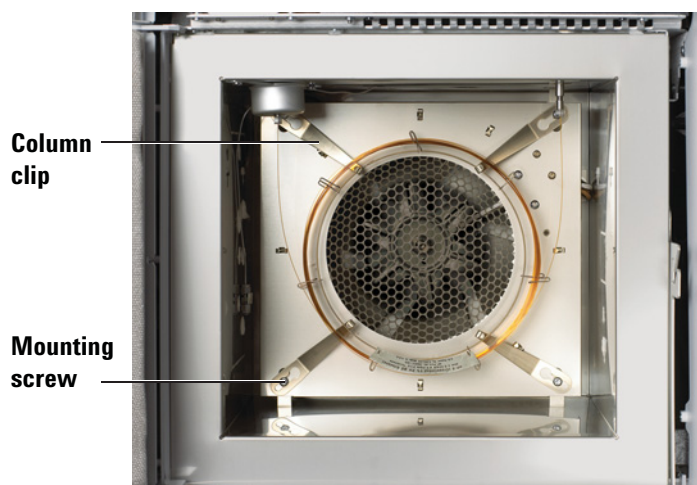

- 3 Slip each corner screw through the large hole on the clip.
- 4 Slide the clip so that the screw is positioned in the slot.
- 5 Tighten the screws enough to hold the clips in place.  
Once the column is installed, fully tighten the four corner screws to secure the clips and column to the oven wall.

## To Condition a Capillary Column

- 1 Gather the following:
  - One 7/16-inch, and 1/4-inch wrenches
  - No-hole ferrule (See [“Consumables and Parts for Columns”](#) on page 30.)
  - Column nut

**WARNING**

**Do not use hydrogen as the carrier for conditioning! It could vent into the oven and present an explosion hazard.**

---

- 2 Load the [GC maintenance method](#) and wait for the GC to become ready.

**WARNING**

**Be careful! The oven and/or detector may be hot enough to cause burns. If the detector is hot, wear gloves to protect your hands.**

---

**WARNING**

**Wear safety glasses to protect your eyes from flying particles while handling, cutting, or installing glass or fused silica capillary columns. Use care in handling these columns to prevent puncture wounds.**

---

- 3 Install the column into the inlet using the new ferrules. See:
  - [To Install a Capillary Column with the Split/Splitless Inlet](#)
  - [“To Install a Capillary Column with the Multimode Inlet”](#)
  - [To Install a Capillary Column with the Purged Packed Inlet](#)
  - [To Install a Capillary Column with the COC Inlet](#)
  - [To Install a Capillary Column with the PTV Inlet](#)
  - [To Install a Capillary Column with the VI](#)

- 4 Cap the detector column fitting.

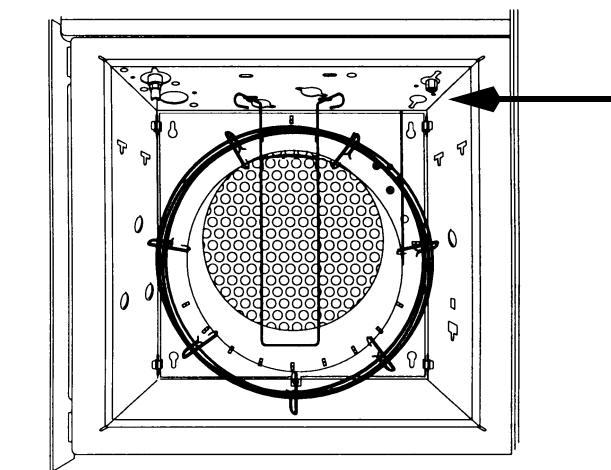

- 5 Set a minimum velocity of 30 cm/s, or as recommended by the column manufacturer. Let gas flow through the column at room temperature for 15 to 30 minutes to remove air.
- 6 Program the oven from room temperature to the maximum temperature limit for the column. Increase the temperature at a rate of 10 to 15 °C/min. Hold at the maximum temperature for 30 minutes.
- 7 Load the [GC maintenance method](#) and wait for the GC to become ready.

**WARNING**

**Be careful! The oven and/or detector may be hot enough to cause burns. If the detector is hot, wear gloves to protect your hands.**

**WARNING**

**Wear safety glasses to protect your eyes from flying particles while handling, cutting, or installing glass or fused silica capillary columns. Use care in handling these columns to prevent puncture wounds.**

- 8 Attach the column to the detector. For details, select your specific detector from the following list:
- [To Install a Capillary Column in the FID](#)
  - [To Install a Capillary Column in the NPD](#)
  - [To Install a Capillary Column in the TCD](#)
  - [To Install a Capillary Column in the uECD](#)
  - [To install a Capillary Column in the FPD Plus](#)

## 4 Maintaining Capillary Columns

- To Install a Capillary Column Adapter in the FPD
- 9 Restore the analytical method.
    - For FID or any FPD, immediately turn off the flame.
    - For NPD, immediately turn off the bead.
  - 10 After the GC becomes ready, wait 10 minutes, then ignite the detector flame or bead.

## To Cut a Loop from a Column

- 1 Gather the following:
  - New ferrule(s) for the column inlet connection
  - Column cutter
- 2 Load the [inlet maintenance method](#) and wait for the GC to become ready.

**WARNING**

**Be careful! The oven and/or inlet may be hot enough to cause burns. If the inlet is hot, wear heat-resistant gloves to protect your hands.**

---

**WARNING**

**Wear safety glasses to protect your eyes from flying particles while handling, cutting, or installing glass or fused silica capillary columns. Use care in handling these columns to prevent puncture wounds.**

---

- 3 Loosen the inlet column nut and remove the column from the inlet.
- 4 Uncoil one loop of column from the column hanger.
- 5 Cut the unwanted loop from the column.
- 6 Install the column into the inlet using the new ferrules. See:
  - [To Install a Capillary Column with the Split/Splitless Inlet](#)
  - [To Install a Capillary Column with the Multimode Inlet](#)
  - [To Install a Capillary Column with the Purged Packed Inlet](#)
  - [To Install a Capillary Column with the COC Inlet](#)
  - [To Install a Capillary Column with the PTV Inlet](#)
  - [To Install a Capillary Column with the VI](#)

## To Reverse a Column and Bakeout Contaminants

- 1 Gather the following:
  - 1/4-inch wrench
  - Column cutter
- 2 Load the [maintenance method](#) and wait for the GC to become ready.

**WARNING**

**Be careful! The oven and/or detector may be hot enough to cause burns. If the detector is hot, wear gloves to protect your hands.**

---

**WARNING**

**Wear safety glasses to protect your eyes from flying particles while handling, cutting, or installing glass or fused silica capillary columns. Use care in handling these columns to prevent puncture wounds.**

---

- 3 Disconnect the column from the inlet and detector.
- 4 If necessary, cut a loop from the column. (See [“To Cut a Loop from a Column”](#) on page 37.) Do not attach the column to the inlet.
- 5 Remove the column from the hanger and reverse its position (inlet and detector ends) and place the column back on the hanger.
- 6 Attach the column to the inlet.

Select your specific inlet from the following list:

- [To Install a Capillary Column with the Split/Splitless Inlet](#)
- [To Install a Capillary Column with the Purged Packed Inlet](#)
- [To Install a Capillary Column with the COC Inlet](#)
- [To Install a Capillary Column with the Multimode Inlet](#)
- [To Install a Capillary Column with the PTV Inlet](#)
- [To Install a Capillary Column with the VI](#)

- 7 Attach your column to the detector.

Select your specific detector from the following list:

- [To Install a Capillary Column in the FID](#)
- [To Install a Capillary Column in the NPD](#)

- To Install a Capillary Column in the TCD
  - To Install a Capillary Column in the uECD
  - To install a Capillary Column in the FPD Plus
  - To Install a Capillary Column Adapter in the FPD
- 8** Set the column flow to the normal operating value, or set the capillary column gas velocity to 30 cm/s.  
  
For Multimode, Split/Splitless, PTV, and VI inlets, select split mode and set the split vent flow to 200 mL/min.
  - 9** Purge the column with carrier flow for at least 10 minutes before heating the oven.
  - 10** Set the inlet temperature to 300 °C or 25 °C above the normal operating temperature.
  - 11** Set the column oven 25 °C above the GC method final oven temperature to bake contaminants out of the inlet, mostly through the split vent. Do not exceed the column manufacturer's maximum temperature limit.
  - 12** Bakeout for 30 minutes.

## To Attach a Capillary Column Using SilTite Metal Fittings

This procedure is used to attach a capillary column to a splitter or switch or an Ultimate Union.

1 Gather the following:

- SilTite ferrules (see [Table 5](#))
- Swaging tool (G2855-60200) or Swaging nut for SilTite ferrules (G2855-20555)
- Two 1/4-inch open-end wrenches
- One 7/16-inch open-end wrench
- Column cutting tool (5181-8836)
- Internal nut (G2855-20530)
- Lint free gloves

**Table 5** Available SilTite metal ferrule packages

Part number	SilTite ferrule description
5188-5361	For 0.2- to 0.25-mm columns
5188-5362	For 0.32-mm columns
5188-5363	For 0.53-mm columns

### CAUTION

Wear clean, lint-free gloves to prevent contamination of parts with dirt and skin oils.

2 Pass the tubing end through the internal nut and SilTite ferrule leaving approximately 1 cm of fused silica tubing protruding beyond the ferrule. Thread the swaging tool over the column.

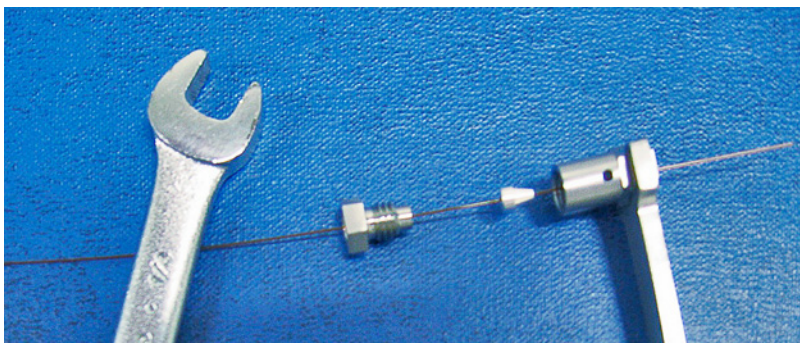



- 3 Using a wrench and the swaging tool to tighten the nut into the tool a little at a time, occasionally checking to see if the ferrule is gripping the tube. When the ferrule just starts to grip, notice the position of the nut and then tighten by turning 45 to 60 degrees of rotation, but no more than 60 degrees (one flat).
- 4 Remove the swaging tool.

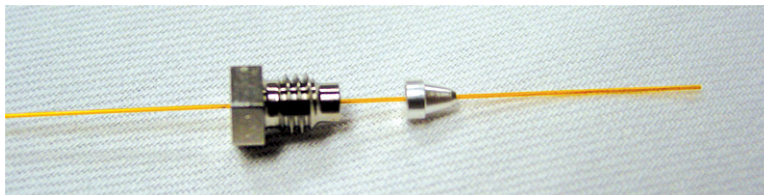

- 5 Using a wafer column cutter, trim the tubing at the small end of the ferrule, leaving approximately 0.3 mm of tubing extending beyond the ferrule.

Check the end of the tube with a magnifier. The end of the tube need not be perfectly square, but should not have cracks that extend under the ferrule.

**NOTE**

It is important that the tube end does not extend beyond 0.5 mm from the end of the ferrule.

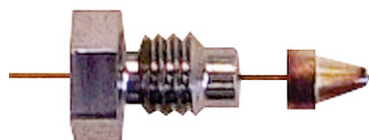

- 6 Insert the assembled ferrule and nut into the SilTite fitting. Tighten with a wrench by only 15 to 20 degrees of rotation.

## To Disconnect Fused Silica Tubing From a SilTite Fitting

Loosen and remove the internal nut. If tubing and ferrule do not come free, insert a pointed object (pen, paper clip) into the ferrule release hole and press firmly. You will hear a click as the ferrule releases.

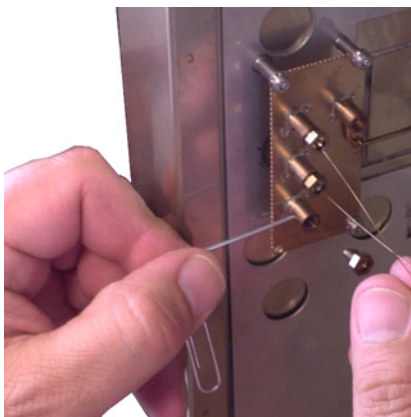

The SilTite ferrule seal should remain leak-free for many disconnections and reconnections.

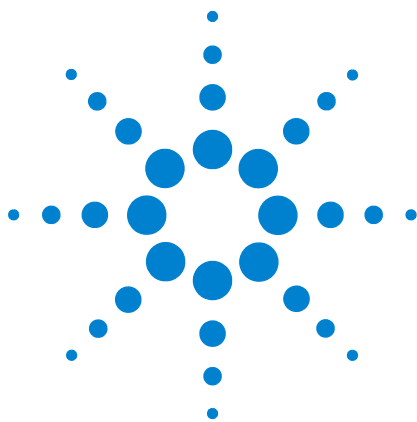

## 5 Maintaining the Split/Splitless Inlet

- Consumables and Parts for the Split/Splitless Inlet 44
- Exploded Parts View of the Split/Splitless Inlet 47
- To Install a Capillary Column with the Split/Splitless Inlet 48
- To Change the Septum on the Split/Splitless Inlet 52
- To Clean the Septum Seat in the Insert Assembly of the Split/Splitless Inlet 54
- To Change the Liner and O-Ring on the Split/Splitless Inlet 56
- To Replace the Gold Seal on the Split/Splitless Inlet 59
- To Replace the Filter in the Split Vent Line for the Split/Splitless Inlet 61
- To Clean the Split/Splitless Inlet 64
- To Bakeout Contaminants from the Split/Splitless Inlet 66



## Consumables and Parts for the Split/Splitless Inlet

See the Agilent catalog for consumables and supplies for a more complete listing, or visit the Agilent Web site for the latest information ([www.agilent.com/chem/supplies](http://www.agilent.com/chem/supplies)).

**Table 6** Split, splitless, direct, and direct connect inlet liners

Mode	Description	Deactivated	Part number
Split	Low-pressure drop, glass wool, single taper, 870 $\mu$ L	Yes	5183-4647
Split	Glass wool, 990 $\mu$ L	No	19251-60540
Split	MS Certified, single taper, glass wool	Yes	5188-6576
Split—Manual only	Empty pin and cup, 800 $\mu$ L	No	18740-80190
Split—Manual only	Packed pin and cup, 800 $\mu$ L	No	18740-60840
Split or splitless	Ultra Inert, low pressure drop, glass wool	Yes	5190-2295
Splitless	Single taper, glass wool, 900 $\mu$ L	Yes	5062-3587
Splitless	Single taper, no glass wool, 900 $\mu$ L	Yes	5181-3316
Splitless	Dual taper, no glass wool, 800 $\mu$ L	Yes	5181-3315
Splitless	MS Certified, single taper, glass wool	Yes	5188-6568
Splitless—Direct inject	2-mm id, quartz, 250 $\mu$ L	No	18740-80220
Splitless—Direct inject	2-mm id, 250 $\mu$ L	Yes	5181-8818
Direct inject —Headspace or purge and trap	1.5-mm id, 140 $\mu$ L	No	18740-80200
Direct column connect	Single taper, splitless 4-mm id	Yes	G1544-80730
Direct column connect	Dual taper, splitless 4-mm id	Yes	G1544-80700

**Table 7** Nuts, ferrules, and hardware for capillary columns

Column id (mm)	Description	Typical use	Part number/quantity
.530	Ferrule, Vespel/graphite, 0.8-mm id	0.45-mm and 0.53-mm capillary columns	5062-3512 (10/pk)
	Ferrule, graphite, 1.0-mm id	0.53-mm capillary columns	5080-8773 (10/pk)
	Ferrule, graphite, 0.8-mm id	0.53-mm capillary columns	500-2118 (10/pk)
	Column nut, finger-tight (for 0.53-mm columns)	Connect column to inlet or detector	5020-8293

**Table 7** Nuts, ferrules, and hardware for capillary columns (continued)

Column id (mm)	Description	Typical use	Part number/quantity
.320	Ferrule, Vespel/graphite, 0.5-mm id	0.32-mm capillary columns	5062-3514 (10/pk)
	Ferrule, graphite, 0.5-mm id	0.1-mm, 0.2-mm, 0.25-mm, and 0.32-mm capillary columns	5080-8853 (10/pk)
	Column nut, finger-tight (for .100- to .320-mm columns)	Connect column to inlet or detector	5020-8292
.250	Ferrule, Vespel/graphite, 0.4-mm id	0.1-mm, 0.2-mm, and 0.25-mm capillary columns	5181-3323 (10/pk)
	Ferrule, graphite, 0.5-mm id	0.1-mm, 0.2-mm, 0.25-mm, and 0.32-mm capillary columns	5080-8853 (10/pk)
	Column nut, finger-tight (for .100- to .320-mm columns)	Connect column to inlet or detector	5020-8292
.100 and .200	Ferrule, Vespel/graphite, 0.37-mm id	0.1-mm and 0.2-mm capillary columns	5062-3516 (10/pk)
	Ferrule, Vespel/graphite, 0.4-mm id	0.1-mm, 0.2-mm, and 0.25-mm capillary columns	5181-3323 (10/pk)
	Ferrule, graphite, 0.5-mm id	0.1-mm, 0.2-mm, 0.25-mm, and 0.32-mm capillary columns	5080-8853 (10/pk)
	Ferrule, graphite, 0.4-mm id		500-2114 (10/pk)
	Column nut, finger-tight (for .100- to .320-mm columns)	Connect column to inlet or detector	5020-8292
All	Ferrule, no-hole	Testing	5181-3308 (10/pk)
	Capillary column blanking nut	Testing—use with any ferrule	5020-8294
	Column nut, universal	Connect column to inlet or detector	5181-8830 (2/pk)
	Column cutter, ceramic wafer	Cutting capillary columns	5181-8836 (4/pk)
	Pencil, diamond tipped	Cutting capillary columns	420-1000
	Ferrule tool kit	Ferrule installation	440-1000

**Table 8** Other consumables and parts for the split/splitless inlet

Description/quantity	Part number
Septum retainer nut for headspace	18740-60830
Septum retainer nut	18740-60835
11-mm septum, high-temperature, low-bleed, 50/pk	5183-4757

**Table 8** Other consumables and parts for the split/splitless inlet

<b>Description/quantity</b>	<b>Part number</b>
11-mm septum, prepierced, long life, 50/pk	5183-4761
Merlin Microseal septum (high-pressure)	5182-3444
Merlin Microseal septum (30 psi)	5181-8815
Nonstick fluorocarbon liner O-ring (for temperatures up to 350 °C), 10/pk	5188-5365
Graphite O-ring for split liner (for temperatures above 350 °C), 10/pk	5180-4168
Graphite O-ring for splitless liner (for temperatures above 350 °C), 10/pk	5180-4173
Split vent trap PM kit, single cartridge	5188-6495
Retaining nut	G1544-20590
Gold-plated seal (standard application)	5188-5367
Gold-plated seal with cross (high split flows) (includes SS washer)	5182-9652
Stainless steel washer (0.375-inch od), 12/pk	5061-5869
Reducing nut	18740-20800
Column nut, blanking plug	5020-8294
Capillary inlet preventative maintenance kit, split	5188-6496
Capillary inlet preventative maintenance kit, splitless	5188-6497

## Exploded Parts View of the Split/Splitless Inlet

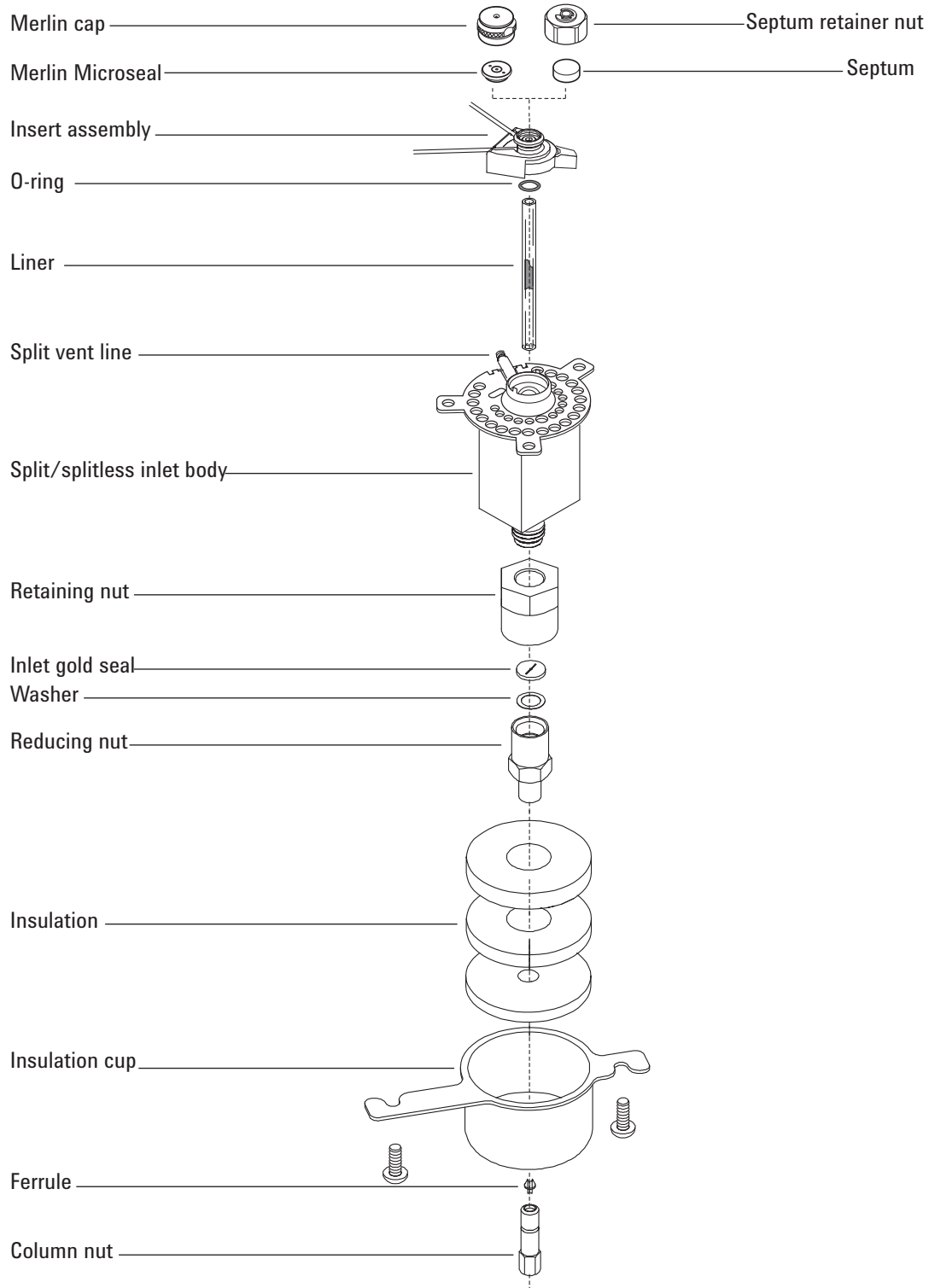

## To Install a Capillary Column with the Split/Splitless Inlet

**WARNING**

Do not use hydrogen as the carrier for conditioning! It could vent into the oven and present an explosion hazard.

---

- 1 Gather the following (see “Consumables and Parts for the Split/Splitless Inlet” on page 44):
  - Column
  - Ferrule(s)
  - Column nut
  - Septum
  - Column cutter
  - Isopropanol
  - Lab tissue
  - Metric ruler
  - 1/4-inch open-end wrench
  - Lint-free gloves
- 2 Load the [GC maintenance method](#) and wait for the GC to become ready.

**WARNING**

Be careful! The oven and/or inlet may be hot enough to cause burns. If either is hot, wear heat-resistant gloves to protect your hands.

---

**WARNING**

Wear safety glasses to protect your eyes from flying particles while handling, cutting, or installing glass or fused silica capillary columns. Use care in handling these columns to prevent puncture wounds.

---

- 3 Verify that the correct glass liner is installed. (See “Consumables and Parts for the Split/Splitless Inlet” on page 44.)
- 4 Place the column on the hanger with the ends pointing up and the label to the front.



**CAUTION**

Wear clean, lint-free gloves to prevent contamination of parts with dirt and skin oils.

- Place a septum, capillary column nut, and ferrule on the column.

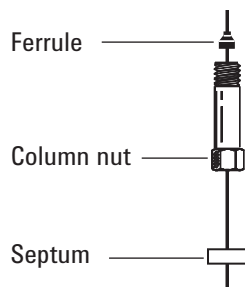

- Score the column using a glass scribing tool. The score must be square to ensure a clean break.

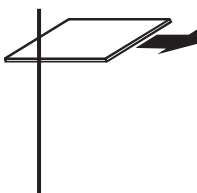

- Break off the column end by supporting it against the column cutter opposite the scribe. Inspect the end with a magnifying loupe to make certain there are no burrs or jagged edges.

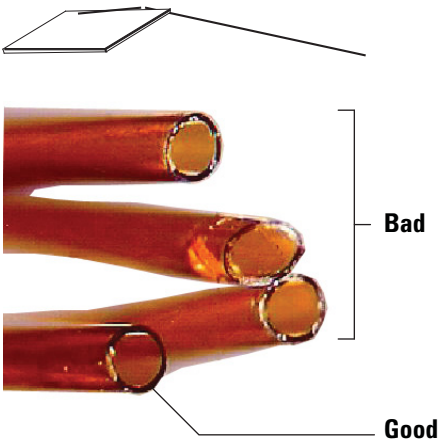

- Wipe the column walls with a tissue dampened with isopropanol to remove fingerprints and dust.

- 9 Position the column so it extends 4 to 6 mm above the end of the ferrule. Slide the septum up the column to hold the column nut at this position.

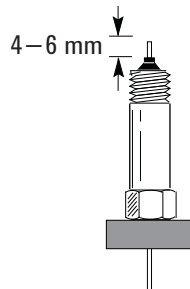

- 10 Thread the column nut into the inlet but do not tighten.

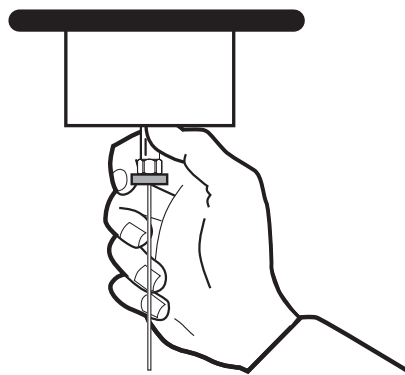

- 11 Adjust the column position so that the septum contacts the bottom of the column nut. Finger-tighten the column nut until it begins to grip the column.
- 12 Tighten the column nut an additional 1/4 to 1/2 turn with a wrench so that the column cannot be pulled from the fitting with gentle pressure.
- 13 Configure the new column. If using the optional barcode scanner, scan the column directly into your data system software configuration, then download the changes to the GC.
- 14 Condition the column per the manufacturer's recommendation. (See [To Condition a Capillary Column.](#))
- 15 Install the column into the detector. See:
- [To Install a Capillary Column in the FID](#)
  - [To Install a Capillary Column in the NPD](#)
  - [To Install a Capillary Column in the TCD](#)
  - [To Install a Capillary Column in the uECD](#)
  - [To install a Capillary Column in the FPD Plus](#)
  - [To Install a Capillary Column Adapter in the FPD](#)

- 16 After the column is installed at both inlet and detector, establish a flow of carrier gas and purge as recommended by the column manufacturer.
- 17 Restore the analytical method.
  - For FID or FPD, immediately turn off the flame.
  - For NPD, immediately turn off the bead.
- 18 After the GC becomes ready, wait 10 minutes then ignite the detector flame or bead.

**WARNING**

**Be careful! The oven, inlet, and/or detector may be hot enough to cause burns. If they are hot, wear heat-resistant gloves to protect your hands.**

---

- 19 Allow the oven, inlet, and detector to equilibrate at operating temperature, then retighten the fittings.
- 20 Reset the EMF counter. See [To Reset an EMF Counter](#) in the *Operation Manual*.

## To Change the Septum on the Split/Splitless Inlet

- 1 Gather the following:
  - Replacement septum. (See “Consumables and Parts for the Split/Splitless Inlet” on page 44.)
  - Wrench, hex for changing septum
  - 0- or 00-grade steel wool (optional)
  - Tweezers
  - Wrench, capillary inlet (optional)
- 2 Load the [inlet maintenance method](#) and wait for the GC to become ready.

**WARNING**

**Be careful! The oven and/or inlet may be hot enough to cause burns. If the inlet is hot, wear heat-resistant gloves to protect your hands.**

- 3 Remove the septum retainer nut or Merlin cap.
- 4 Use tweezers to remove the septum or Merlin Microseal from the insert assembly. Do not gouge or scratch the interior of the insert assembly.

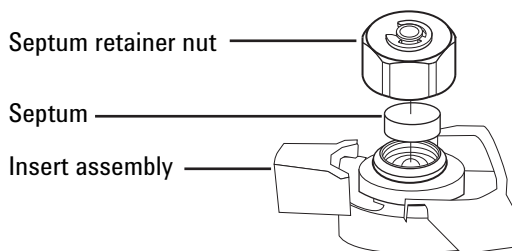

- 5 Firmly press the new septum or Merlin Microseal into the fitting. The metal parts side of the Merlin Microseal should face down (toward the oven).



- 6 Install the septum retainer nut or Merlin cap and finger-tighten. Tighten the septum retainer nut until the C-ring is about 1 mm above the nut.

**CAUTION**

Overtightening the septum nut can cause contamination.

---

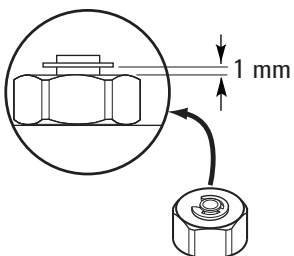

- 7 Restore the analytical method.
- 8 Reset the EMF counter. See [To Reset an EMF Counter](#) in the *Operation Manual*.

## To Clean the Septum Seat in the Insert Assembly of the Split/Splitless Inlet

- 1 Gather the following:
  - Replacement septum (See “Consumables and Parts for the Split/Splitless Inlet” on page 44.)
  - Wrench, hex for changing septum
  - 0- or 00-grade steel wool (optional)
  - Tweezers
  - Compressed, filtered, dry air or nitrogen
  - Wrench, capillary inlet (optional)
- 2 Load the [inlet maintenance method](#) and wait for the GC to become ready.

**WARNING**

**Be careful! The oven and/or inlet may be hot enough to cause burns. If either is hot, wear heat-resistant gloves to protect your hands.**

- 3 Slide the locking tab forward (counterclockwise). Lift the septum assembly straight up and away from the inlet to avoid chipping or breaking the liner.

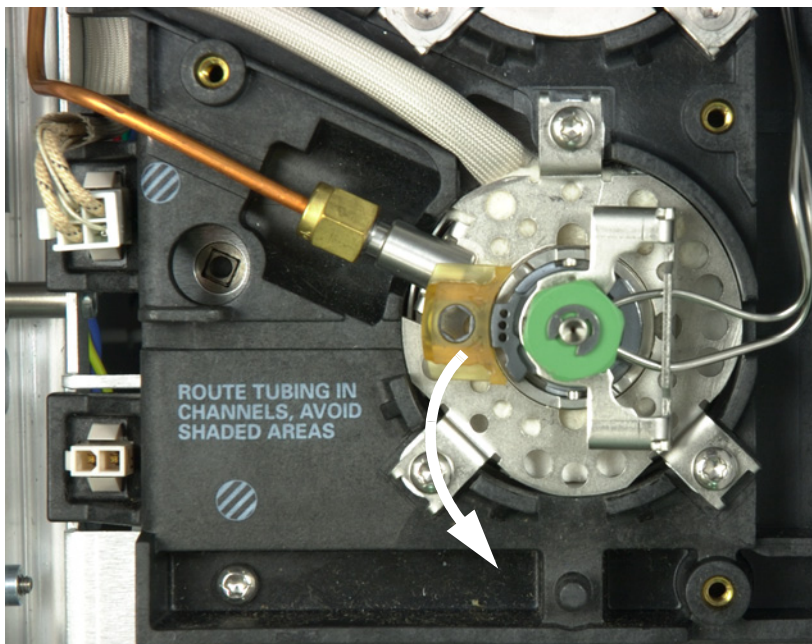

- 4 Remove the septum retainer nut or Merlin cap.

- 5 Use tweezers to remove the septum or Merlin Microseal from the retainer nut. (See [“To Change the Septum on the Split/Splitless Inlet”](#) on page 52.)
- 6 Scrub the residue from the retainer nut and septum holder with a small piece of rolled-up steel wool and tweezers. Do not do this over the inlet.
- 7 Use compressed air or nitrogen to blow away the pieces of steel wool and septum.
- 8 Line up the tab on the bottom of the septum assembly with the slot on the insert assembly and push down to connect. Slide the locking tab to the left.

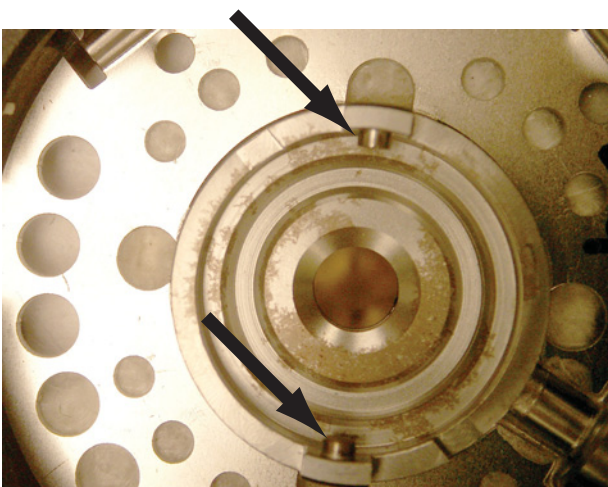

- 9 Firmly press the new septum or Merlin Microseal into the fitting. (See [“To Change the Septum on the Split/Splitless Inlet”](#) on page 52.)
- 10 Replace the septum retainer nut or Merlin cap and finger-tighten. (See [“To Change the Septum on the Split/Splitless Inlet”](#) on page 52.)
- 11 Restore the analytical method.
- 12 Reset the EMF counter. See [To Reset an EMF Counter](#) in the *Operation Manual*.

## To Change the Liner and O-Ring on the Split/Splitless Inlet

- 1 Gather the following:
  - Replacement O-ring (See “Consumables and Parts for the Split/Splitless Inlet” on page 44.)
  - Replacement liner
  - Tweezers
  - Wrench, hex for changing septum
  - Wrench, capillary inlet (optional)
  - Lint-free gloves
- 2 Load the [inlet maintenance method](#) and wait for the GC to become ready.

**WARNING**

**Be careful! The oven and/or inlet may be hot enough to cause burns. If either is hot, wear heat-resistant gloves to protect your hands.**

- 3 Slide the locking tab forward (counterclockwise). Lift the septum assembly straight up and away from the inlet to avoid chipping or breaking the liner.

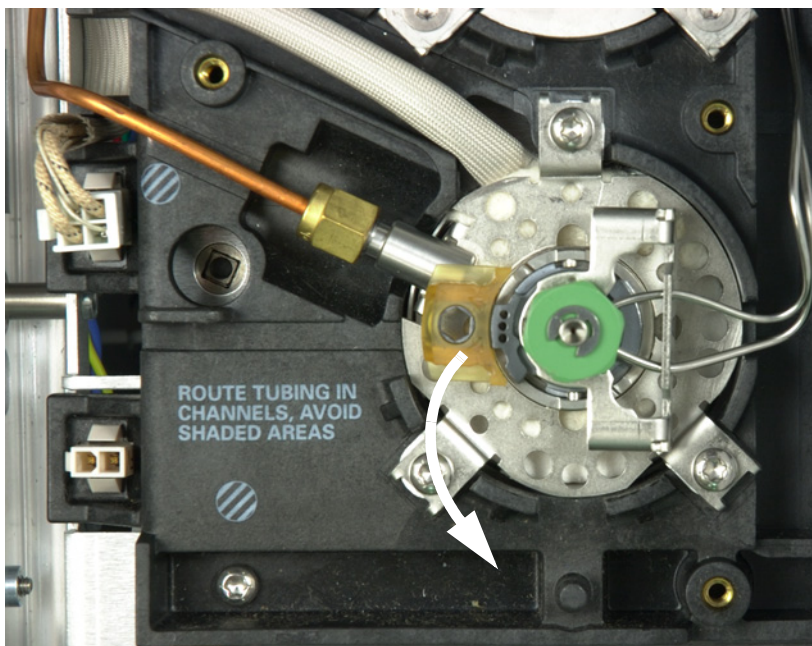

- 4 Loosen the O-ring from the sealing surface with tweezers.



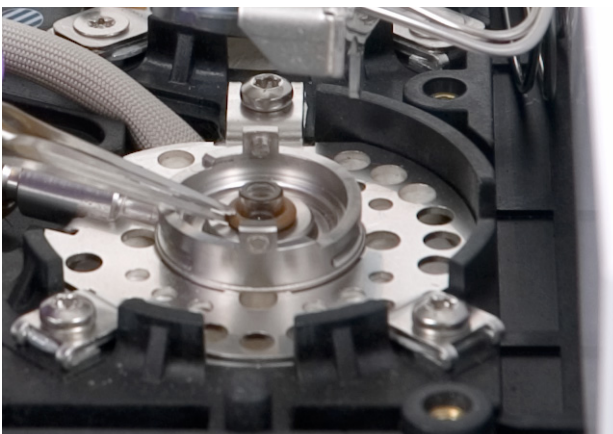

5 Grasp the liner with tweezers and pull it out.



6 Inspect the surface of the gold seal for graphite or rubber septum contamination. If required, replace the gold seal. (See [“To Replace the Gold Seal on the Split/Splitless Inlet”](#) on page 59.)



Clean the inlet if there is visible or suspected contamination. (See [“To Clean the Split/ Splitless Inlet”](#) on page 64.)

Clean O-ring residue from sealing surface.

### CAUTION

Wear clean, lint-free gloves to prevent contamination of parts with dirt and skin oils.

- 7 Slide a new O-ring onto the replacement liner.
- 8 Return the liner to the inlet, pushing it all the way in until the liner contacts the gold seal.



- 9 Line up the tab on the bottom of the septum assembly with the slot on the insert assembly and push down to connect. Slide the locking tab to the back.
- 10 Turn on the inlet. Allow the inlet and column to purge with carrier gas for 15 minutes before heating the inlet or the column oven.
- 11 Bakeout contaminants. (See [“To Bakeout Contaminants from the Split/ Splitless Inlet”](#) on page 66.)
- 12 Restore the analytical method.
- 13 Reset the liner counter. See [To Reset an EMF Counter](#) in the *Operation Manual*.
- 14 If using the optional barcode scanner, scan the liner information directly into your data system software configuration, then download the changes to the GC.
- 15 Check for leaks.

## To Replace the Gold Seal on the Split/Splitless Inlet

- 1 Gather the following:
  - Replacement gold seal (See “Consumables and Parts for the Split/Splitless Inlet” on page 44.)
  - Replacement washer
  - 1/4-inch wrench (for column)
  - 1/2-inch wrench
  - Lint-free gloves
- 2 Load the [inlet maintenance method](#) and wait for the GC to become ready.

**WARNING**

**Be careful! The oven and/or inlet may be hot enough to cause burns. If either is hot, wear heat-resistant gloves to protect your hands.**

---

- 3 Remove the inlet liner.
- 4 Remove the column from the inlet. Cap the open end of the column to prevent contamination. Remove the insulation cup around the base of the inlet.

Remove insulation cup

Disconnected, capped column



- 5 Loosen and remove the reducing nut. Remove the washer and seal inside the reducing nut.



**CAUTION**

Wear clean, lint-free gloves to prevent contamination of parts with dirt and skin oils.

- Put on gloves to protect the new gold seal and washer from contamination. Put a new washer in the reducing nut and place the new gold seal on top of it (raised portion facing down).

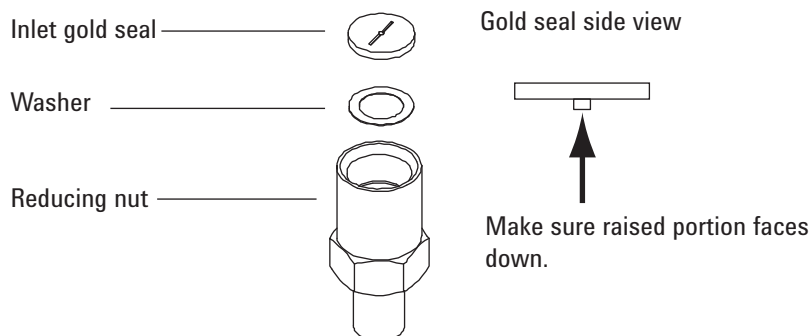

- Replace the reducing nut and tighten securely with a wrench.
- Replace the inlet liner.
- Install the column and the insulation cup.
- Bakeout contaminants. (See [“To Bakeout Contaminants from the Split/Splitless Inlet”](#) on page 66.)
- Restore the analytical method.
- Reset the EMF counter. See [To Reset an EMF Counter](#) in the *Operation Manual*.
- Check for leaks.

## To Replace the Filter in the Split Vent Line for the Split/Splitless Inlet

- 1 Gather the following:
  - New filter cartridge. (See “Consumables and Parts for the Split/Splitless Inlet” on page 44.)
  - T-20 Torx screwdriver
- 2 Load the [inlet maintenance method](#) and wait for the GC to become ready.

**WARNING**

Be careful! The oven and/or inlet may be hot enough to cause burns. If either is hot, wear heat-resistant gloves to protect your hands.

**WARNING**

The split vent trap may contain residual amounts of any samples or other chemicals you have injected into the GC. Follow your company’s safety procedures for handling these types of substances while replacing the trap filter cartridge.

- 3 Remove the [pneumatics cover](#) (top, back of GC).
- 4 Remove the retaining clip.

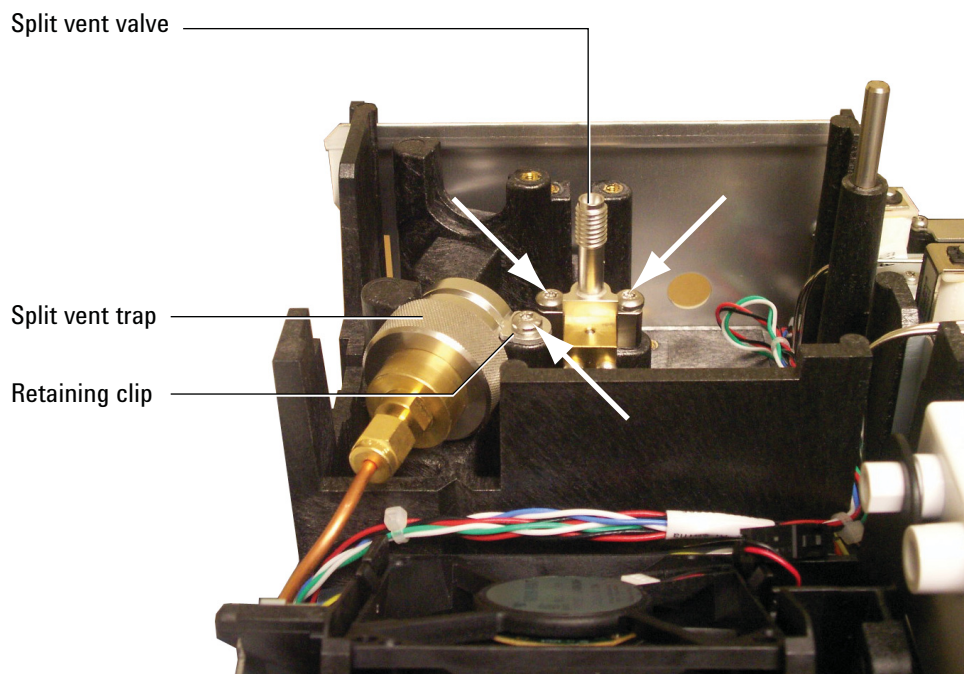

- 5** Completely loosen the two screws that secure the split vent valve in place.
- 6** Lift the filter trap assembly and split vent valve from the mounting bracket together and unscrew the split vent front weldment on the filter trap assembly. Be careful not to stress the tubing between the split vent valve and the trap.

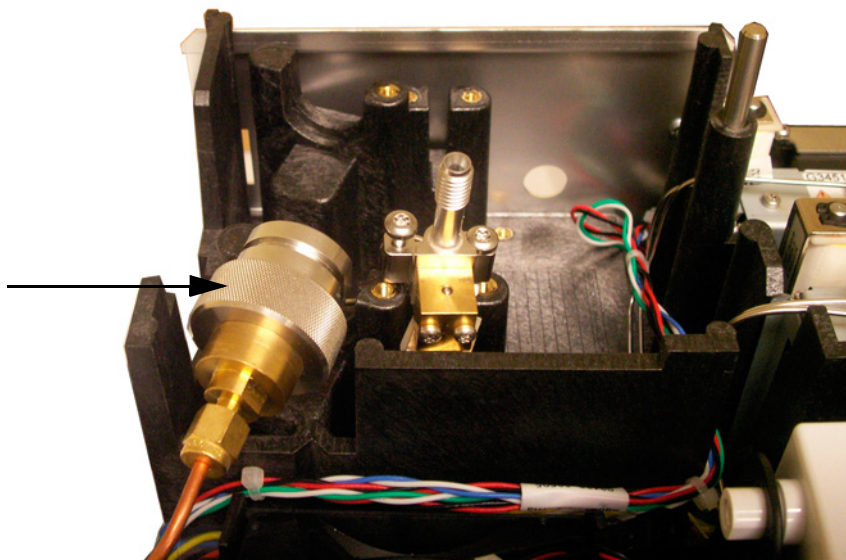

- 7** Remove the old filter cartridge and two O-rings.

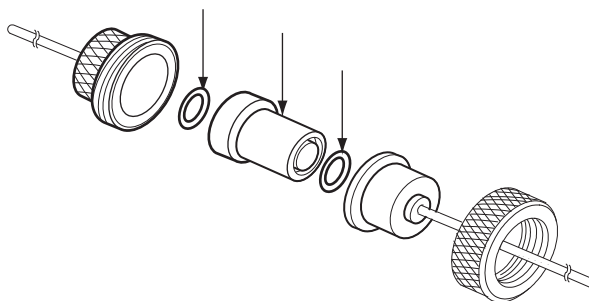

- 8** Verify the new O-rings are seated properly on the new filter cartridge.
- 9** Install the new filter cartridge then reassemble the trap. Do not fully tighten yet.
- 10** Place the filter trap assembly in the mounting bracket and install the retaining clip.
- 11** Install the split vent valve.
- 12** Fully tighten the split vent front weldment onto the trap.
- 13** Check for leaks.

- 14 Reset the EMF counter. See [To reset an EMF counter](#).
- 15 Restore the analytical method.
- 16 Reset the split vent trap counter.
- 17 Install the pneumatics cover.

## To Clean the Split/Splitless Inlet

- 1 Gather the following:
  - Replacement septum (See “[Consumables and Parts for the Split/Splitless Inlet](#)” on page 44.)
  - Replacement liner
  - Replacement O-ring
  - Replacement gold seal
  - Replacement washer
  - Solvent that will clean the type of deposits in your inlet
  - Compressed, filtered, dry air or nitrogen
  - Beaker
  - Cleaning brushes—The FID cleaning kit (part number 9301-0985) contains appropriate brushes
  - Lint-free gloves
- 2 Load the [inlet maintenance method](#) and wait for the GC to become ready.

**WARNING**

**Be careful! The oven and/or inlet may be hot enough to cause burns. If the inlet is hot, wear heat-resistant gloves to protect your hands.**

---

- 3 Remove the inlet liner. (See “[To Change the Liner and O-Ring on the Split/Splitless Inlet](#)” on page 56.)
- 4 Disconnect the column from the inlet.
- 5 Remove the reducing nut and gold seal. (See “[To Replace the Gold Seal on the Split/Splitless Inlet](#)” on page 59.)
- 6 Place a beaker in the oven under the inlet to catch the solvent.

**CAUTION**

Wear clean, lint-free gloves to prevent contamination of parts with dirt and skin oils.

---

- 7 Soak a cleaning brush in the solvent and scrub the inside of the inlet weldment. Repeat 10 times.
- 8 Rinse the inlet with the solvent.



- 9 Blow the inside of the inlet dry with compressed air or nitrogen.
- 10 Install the gold seal and reducing nut.
- 11 Install the liner and O-ring.
- 12 Install the column. (See [“To Install a Capillary Column with the Split/Splitless Inlet”](#) on page 48.)
- 13 Check for leaks.
- 14 Bakeout contaminants. (See [“To Bakeout Contaminants from the Split/Splitless Inlet”](#) on page 66.)
- 15 Restore the analytical method.
- 16 Reset the septum and liner EMF counters. See [To Reset an EMF Counter](#) in the *Operation Manual*.

## To Bakeout Contaminants from the Split/Splitless Inlet

- 1 Put the inlet into split mode.
- 2 Set the column flow to the normal operating value, or set the capillary column gas velocity to 30 cm/s.
- 3 Set the inlet split vent flow to 200 mL/min.
- 4 Purge the column with carrier flow for at least 10 minutes before heating the oven.
- 5 If the column is attached to the detector, set the detector 25 °C above normal operating temperature.

**WARNING**

**Be careful! The oven, inlet, and/or detector may be hot enough to cause burns. If they are hot, wear heat-resistant gloves to protect your hands.**

---

If the column is not attached to the detector, cap the detector fitting.

- 6 Set the inlet temperature to 300 °C or 25 °C above the normal operating temperature to bakeout contaminants from the inlet, mostly through the split vent.
- 7 Set the column oven 25 °C above the GC method final oven temperature to bake contaminants from the column. Do not exceed the column manufacturer's maximum temperature limit.
- 8 Bakeout for 30 minutes or until the detector baseline is free of contamination peaks.



## 6 Maintaining the Purged Packed Inlet

Consumables and Parts for the Purged Packed Inlet	68
Exploded Parts View of the Purged Packed Inlet	71
To Install a Capillary Column with the Purged Packed Inlet	72
To Change the Septum on the Purged Packed Inlet	77
To Clean the Septum Seat in the Purged Packed Inlet	79
To Install an Adapter on the Purged Packed Inlet	81
To Change the O-Ring on the Purged Packed Inlet	83
To Change the Glass Liner on the Purged Packed Inlet	84
To Install an Insulation Cup on the Purged Packed Inlet	86
To Clean the Purged Packed Inlet	87
To Bakeout Contaminants from the Purged Packed Inlet	89
To Install a Packed Metal Column	90
To Install a Packed Column Adapter on a Detector Fitting	92
To Install a Packed Glass Column	94
To Condition a Packed Column	97
To Install Ferrules on a Packed Metal Column	99



## Consumables and Parts for the Purged Packed Inlet

See the Agilent catalog for consumables and supplies for a more complete listing, or visit the Agilent Web site for the latest information ([www.agilent.com/chem/supplies](http://www.agilent.com/chem/supplies)).

**Table 9** Purged packed inlet parts

Description	Part number/quantity
Preventative maintenance kit	5188-6498
<b>Purged packed glass liners and column adapters</b>	
Glass liner	5080-8732 (25/pack) or 5181-3382 deactivated (5/pack)
0.53-mm column adapter	19244-80540
1/8-inch column adapter	19243-80530
1/4-inch column adapter	19243-80540
<b>Recommended septa and O-rings for the purged packed inlet</b>	
11-mm solid septum, low-bleed, red	5181-1263 (50/pk)
11-mm septum with partial through-hole, low-bleed, red	5181-3383 (50/pk)
11-mm septum, low-bleed, gray	5080-8896 (50/pk)
Merlin Microseal septum (30 psi)	5181-8815
11-mm high-temperature silicone septum (350 °C and higher)	5182-0739 (50/pk)
Viton O-ring (Top insert weldment)	5080-8898 (12/pk)

**Table 10** Nuts and ferrules for packed columns

Description	Typical use	Part number/quantity
1/8-inch id Swagelok stainless steel nut, front ferrule, back ferrule	1/8-inch column	5080-8751 (20 each/pk)
1/8-inch id Swagelok brass nut, front ferrule, back ferrule	1/8-inch column	5080-8750 (20 each/pk)
1/8-inch id Vespel/ graphite ferrule	1/8-inch column	0100-1332 (10/pk)

**Table 10** Nuts and ferrules for packed columns (continued)

Description	Typical use	Part number/quantity
1/8-inch id brass tubing nut	1/8-inch column	5180-4103 (10/pk)
1/4-inch id Swagelok stainless steel nut, front ferrule, back ferrule	1/4-inch column	5080-8753 (20 each/pk)
1/4-inch id Swagelok brass nut, front ferrule, back ferrule	1/4-inch column	5080-8752 (20 each/pk)
1/4-inch id Vespel/ graphite ferrule	Inlet/detector liner/adapters 1/4-inch column	5080-8774 (10/pk)
1/4-inch id brass tubing nut	1/4-inch column	5180-4105 (10/pk)

**Table 11** Nuts, ferrules, and hardware for capillary columns

Column id (mm)	Description	Typical use	Part number/quantity
.530	Ferrule, Vespel/graphite, 0.8-mm id	0.45-mm and 0.53-mm capillary columns	5062-3512 (10/pk)
	Ferrule, graphite, 1.0-mm id	0.53-mm capillary columns	5080-8773 (10/pk)
	Ferrule, graphite, 0.8-mm id	0.53-mm capillary columns	500-2118 (10/pk)
	Column nut, finger-tight (for 0.53-mm columns)	Connect column to inlet or detector	5020-8293
.320	Ferrule, Vespel/graphite, 0.5-mm id	0.32-mm capillary columns	5062-3514 (10/pk)
	Ferrule, graphite, 0.5-mm id	0.1-mm, 0.2-mm, 0.25-mm, and 0.32-mm capillary columns	5080-8853 (10/pk)
	Column nut, finger-tight (for .100- to .320-mm columns)	Connect column to inlet or detector	5020-8292
.250	Ferrule, Vespel/graphite, 0.4-mm id	0.1-mm, 0.2-mm, and 0.25-mm capillary columns	5181-3323 (10/pk)
	Ferrule, graphite, 0.5-mm id	0.1-mm, 0.2-mm, 0.25-mm, and 0.32-mm capillary columns	5080-8853 (10/pk)
	Column nut, finger-tight (for .100- to .320-mm columns)	Connect column to inlet or detector	5020-8292
.100 and .200	Ferrule, Vespel/graphite, 0.37-mm id	0.1-mm and 0.2-mm capillary columns	5062-3516 (10/pk)

## 6 Maintaining the Purged Packed Inlet

**Table 11** Nuts, ferrules, and hardware for capillary columns (continued)

Column id (mm)	Description	Typical use	Part number/quantity
	Ferrule, Vespel/graphite, 0.4-mm id	0.1-mm, 0.2-mm, and 0.25-mm capillary columns	5181-3323 (10/pk)
	Ferrule, graphite, 0.5-mm id	0.1-mm, 0.2-mm, 0.25-mm, and 0.32-mm capillary columns	5080-8853 (10/pk)
	Ferrule, graphite, 0.4-mm id		500-2114 (10/pk)
	Column nut, finger-tight (for .100- to .320-mm columns)	Connect column to inlet or detector	5020-8292
All	Ferrule, no-hole	Testing	5181-3308 (10/pk)
	Capillary column blanking nut	Testing—use with any ferrule	5020-8294
	Column nut, universal	Connect column to inlet or detector	5181-8830 (2/pk)
	Column cutter, ceramic wafer	Cutting capillary columns	5181-8836 (4/pk)
	Pencil, diamond tipped	Cutting capillary columns	420-1000
	Ferrule tool kit	Ferrule installation	440-1000

## Exploded Parts View of the Purged Packed Inlet

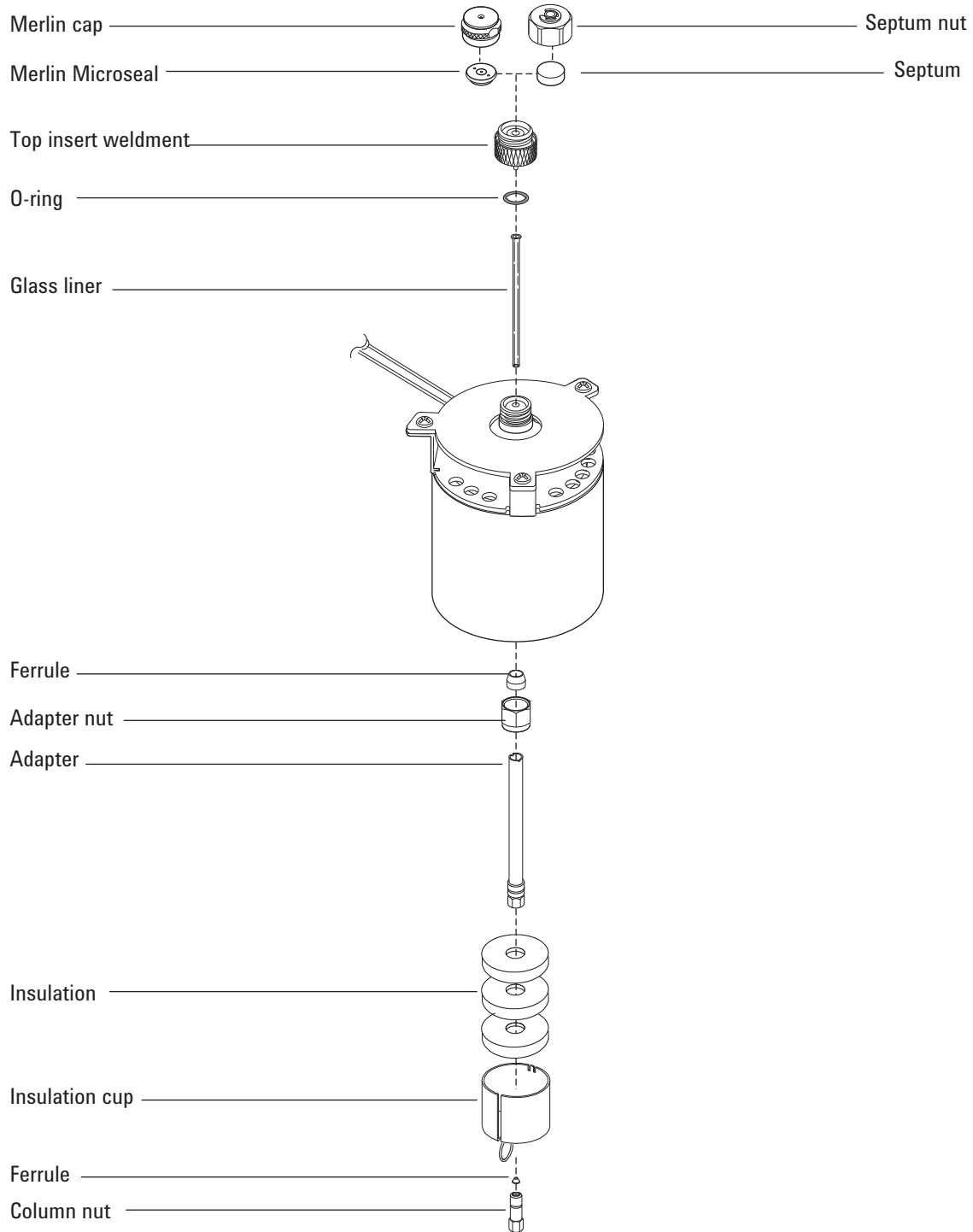

## To Install a Capillary Column with the Purged Packed Inlet

- 1 Gather the following:
  - Column
  - Ferrule (See [“Consumables and Parts for the Purged Packed Inlet”](#) on page 68.)
  - Column nut
  - Glass liner
  - Viton O-ring
  - 0.53-mm column adapter
  - Septum
  - 1/4-inch wrench
  - Metric ruler
  - Lint-free gloves
- 2 Load the [inlet maintenance method](#) and wait for the GC to become ready.

**WARNING**

**Be careful! The oven and/or inlet may be hot enough to cause burns. If the inlet is hot, wear heat-resistant gloves to protect your hands.**

---

**WARNING**

**Wear safety glasses to protect your eyes from flying particles while handling, cutting, or installing glass or fused silica capillary columns. Use care in handling these columns to prevent puncture wounds.**

---

- 3 Install a 0.53-mm column adapter. (See [“To Install an Adapter on the Purged Packed Inlet”](#) on page 81.)

**CAUTION**

Wear clean, lint-free gloves to prevent contamination of parts with dirt and skin oils.

---

- 4 Install a new Viton O-ring. (See [“To Change the O-Ring on the Purged Packed Inlet”](#) on page 83.)
- 5 Place a septum, capillary column nut, and ferrule on the column.



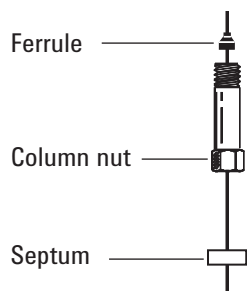

- 6 Score the column using a glass scribing tool. The score must be square to ensure a clean break.

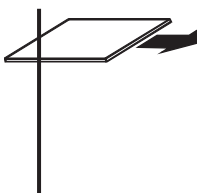

- 7 Break off the column end by supporting it against the column cutter opposite the scribe. Inspect the end with a magnifying loupe to make certain there are no burrs or jagged edges.

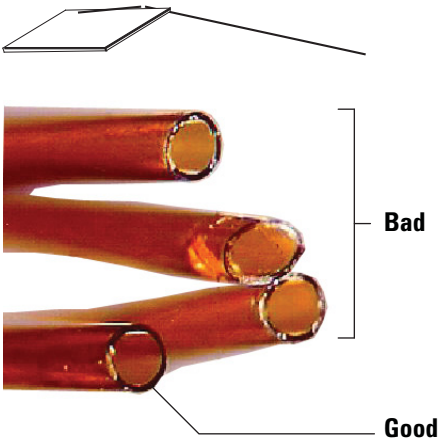

- 8 Wipe the column walls with a tissue dampened with isopropanol to remove fingerprints and dust.
- 9 Position the column so it extends 1 to 2 mm above the end of the ferrule. Slide the septum up the column to hold the column nut at this fixed position.

## 6 Maintaining the Purged Packed Inlet

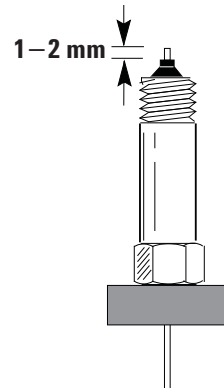

- 10** Thread the column nut into the inlet adapter but do not tighten.

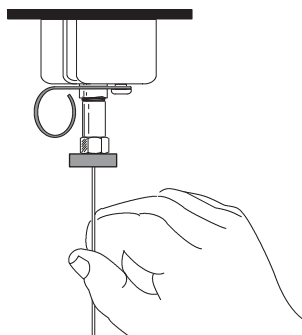

- 11** Adjust the column position so that the septum is even with the bottom of the column nut. Finger-tighten the column nut until it begins to grip the column.
- 12** Tighten the column nut an additional 1/4 to 1/2 turn with a wrench so that the column cannot be pulled from the fitting with gentle pressure.
- 13** Configure the new column. If using the optional barcode scanner, scan the column directly into your data system software configuration, then download the changes to the GC.
- 14** Condition the column per the manufacturer's recommendation. (See [To Condition a Capillary Column.](#))
- 15** Install the column into the detector. See:
- [To Install a Capillary Column in the FID](#)
  - [To Install a Capillary Column in the NPD](#)
  - [To Install a Capillary Column in the TCD](#)
  - [To Install a Capillary Column in the uECD](#)
  - [To install a Capillary Column in the FPD Plus](#)
  - [To Install a Capillary Column Adapter in the FPD](#)
- 16** After the column is installed at both inlet and detector, establish a flow of carrier gas and purge as recommended by the column manufacturer.
- 17** Restore the analytical method.
- For FPD, immediately turn off the flame.
  - For NPD, immediately set the bead voltage to 0.0.
- 18** After the GC becomes ready, wait 10 minutes then ignite the detector flame or adjust offset on the NPD bead.

**WARNING**

**Be careful! The oven, inlet, and/or detector may be hot enough to cause burns. If the oven, inlet, or detector is hot, wear heat-resistant gloves to protect your hands.**

---

- 19 Allow the oven, inlet, and detector to equilibrate at operating temperature, then retighten the fittings.
- 20 Reset the column EMF counters. See [To Reset an EMF Counter](#) in the *Operation Manual*.

## To Change the Septum on the Purged Packed Inlet

- 1 Gather the following:
  - Replacement septum (See “Consumables and Parts for the Purged Packed Inlet” on page 68.)
  - Septum nut wrench
  - 0- or 00-grade steel wool (optional)
  - Tweezers
- 2 Load the [inlet maintenance method](#) and wait for the GC to become ready.

### WARNING

**Be careful! The oven and/or inlet may be hot enough to cause burns. If the inlet is hot, wear heat-resistant gloves to protect your hands.**

- 3 Remove the septum retainer nut or Merlin cap.
- 4 Use tweezers to remove the septum or Merlin Microseal from the retainer nut. Do not gouge or scratch the interior of the septum head.

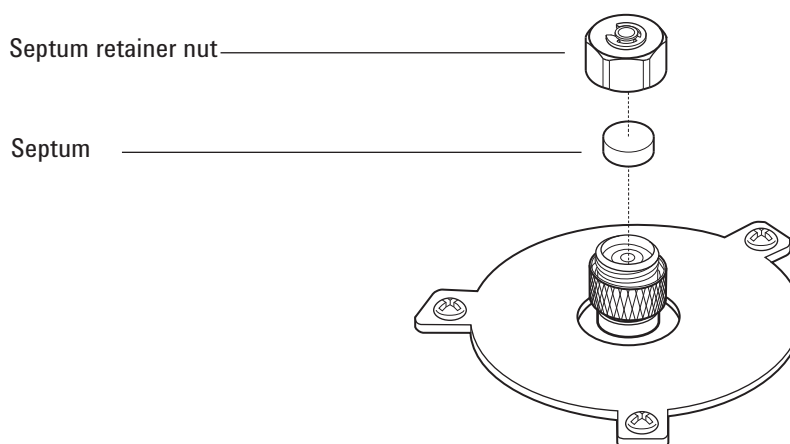

- 5 Firmly press the new septum or Merlin Microseal into the fitting. The metal parts side of the Merlin Microseal should face down (toward the oven).

## 6 Maintaining the Purged Packed Inlet

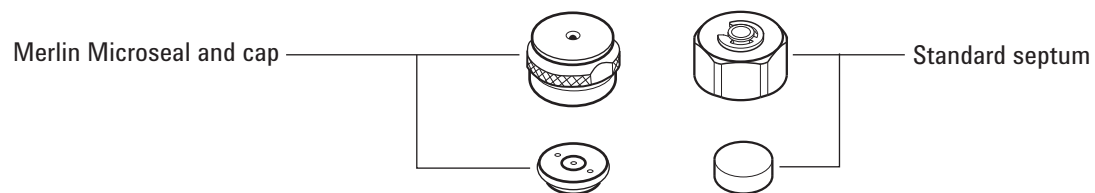

- 6 Replace the septum retainer nut or Merlin cap and finger-tighten. Tighten the septum retainer nut until the C-ring is about 1 mm above the nut.

### CAUTION

Overtightening the septum nut can cause contamination.

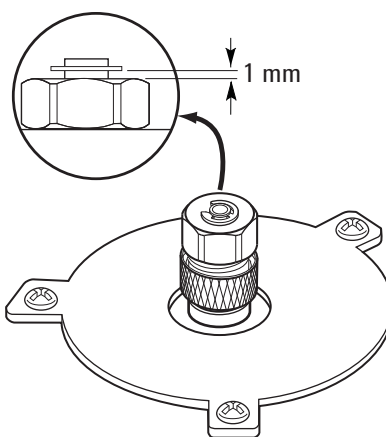

- 7 Restore the analytical method.
- 8 Reset the septum counter.

## To Clean the Septum Seat in the Purged Packed Inlet

- 1 Gather the following:
  - Replacement septum (See “Consumables and Parts for the Purged Packed Inlet” on page 68.)
  - Septum nut wrench
  - 0- or 00-grade steel wool (optional)
  - Tweezers
  - Compressed, filtered, dry air or nitrogen
  - Ultrasonic cleaning bath
  - Lint-free gloves
- 2 Load the [inlet maintenance method](#) and wait for the GC to become ready.

### WARNING

**Be careful! The oven and/or inlet may be hot enough to cause burns. If the inlet is hot, wear heat-resistant gloves to protect your hands.**

---

- 3 Remove the septum retainer nut or Merlin cap.
- 4 Loosen the top insert weldment and remove.

### CAUTION

Wear clean, lint-free gloves to prevent contamination of parts with dirt and skin oils.

---

- 5 Use tweezers to remove the septum or Merlin Microseal from the top insert weldment. Do not gouge or scratch the interior of the septum head.
- 6 Scrub the residue from the top insert weldment and septum nut with a small piece of rolled-up steel wool and tweezers. Ultrasonically clean the retainer nut and top insert weldment.
- 7 Use compressed air or nitrogen to blow away the pieces of steel wool and septum.
- 8 Wearing gloves, inspect the O-ring and replace, if necessary. (See “[To Change the O-Ring on the Purged Packed Inlet](#)” on page 83.)
- 9 Install the top insert weldment and hand-tighten firmly.

- 10** Firmly press the new septum or Merlin Microseal into the fitting.
- 11** Install the septum retainer nut or Merlin cap and finger-tighten. Tighten the septum retainer nut until the C-ring is about 1 mm above the nut.

**CAUTION**

Overtightening the septum nut can cause contamination.

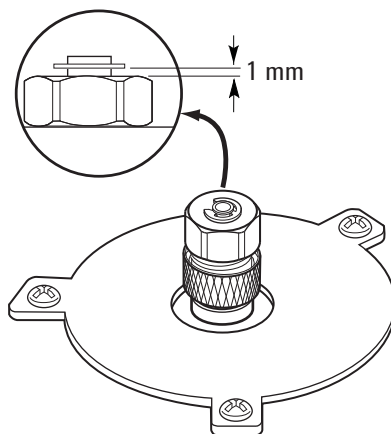

- 12** Restore the analytical method.
- 13** Reset the septum counter.



## To Install an Adapter on the Purged Packed Inlet

- 1 Gather the following:
  - Brass tubing nut (see “Consumables and Parts for the Purged Packed Inlet” on page 68.)
  - Adapter (0.53 mm, 1/8-inch packed, or 1/4-inch packed)
  - 7/16-inch and 9/16-inch wrench
  - Vespel/graphite ferrule
  - Methanol
  - Lint-free gloves
- 2 Load the [inlet maintenance method](#) and wait for the GC to become ready.

**WARNING**

**Be careful! The oven and/or inlet may be hot enough to cause burns. If the inlet is hot, wear heat-resistant gloves to protect your hands.**

---

**CAUTION**

Wear clean, lint-free gloves to prevent contamination of parts with dirt and skin oils.

---

- 3 Clean the end of the adapter with a lint-free cloth and methanol to remove contamination such as fingerprints.
- 4 Place the tubing nut and Vespel/graphite ferrule on the adapter.

## 6 Maintaining the Purged Packed Inlet

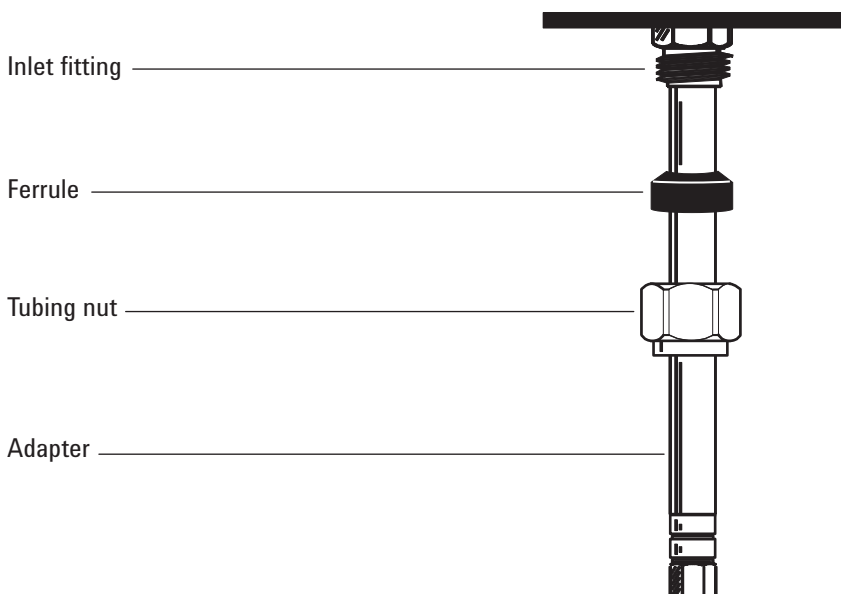

- 5 Insert the adapter straight into the inlet base as far as possible.
- 6 Hold the adapter in this position and finger-tighten the nut.
- 7 Tighten an additional 1/4 turn with a wrench.

## To Change the O-Ring on the Purged Packed Inlet

- 1 Gather the following:
  - Replacement O-ring (See [“Consumables and Parts for the Purged Packed Inlet”](#) on page 68.)
  - Septum nut wrench
  - Tweezers
  - Lint-free gloves
- 2 Load the [inlet maintenance method](#) and wait for the GC to become ready.

### WARNING

**Be careful! The oven and/or inlet may be hot enough to cause burns. If the inlet is hot, wear heat-resistant gloves to protect your hands.**

- 3 Loosen the top insert weldment to remove the top portion of the inlet.

### CAUTION

Wear clean, lint-free gloves to prevent contamination of parts with dirt and skin oils.

- 4 Use tweezers to remove the old O-ring.

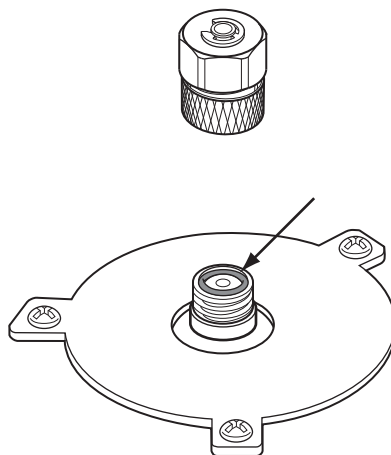

- 5 Insert a new O-ring.
- 6 Install and tighten the top insert weldment.
- 7 Restore the analytical method.
- 8 Reset the EMF counter. See [To Reset an EMF Counter](#) in the *Operation Manual*.

## To Change the Glass Liner on the Purged Packed Inlet

- 1 Gather the following:
  - Replacement glass liner (See “Consumables and Parts for the Purged Packed Inlet” on page 68.)
  - 9/16-inch wrench
  - Lint-free gloves
- 2 Load the [inlet maintenance method](#) and wait for the GC to become ready.

**WARNING**

**Be careful! The oven and/or inlet may be hot enough to cause burns. If the inlet is hot, wear heat-resistant gloves to protect your hands.**

---

- 3 Loosen the top insert weldment to remove the top portion of the inlet.

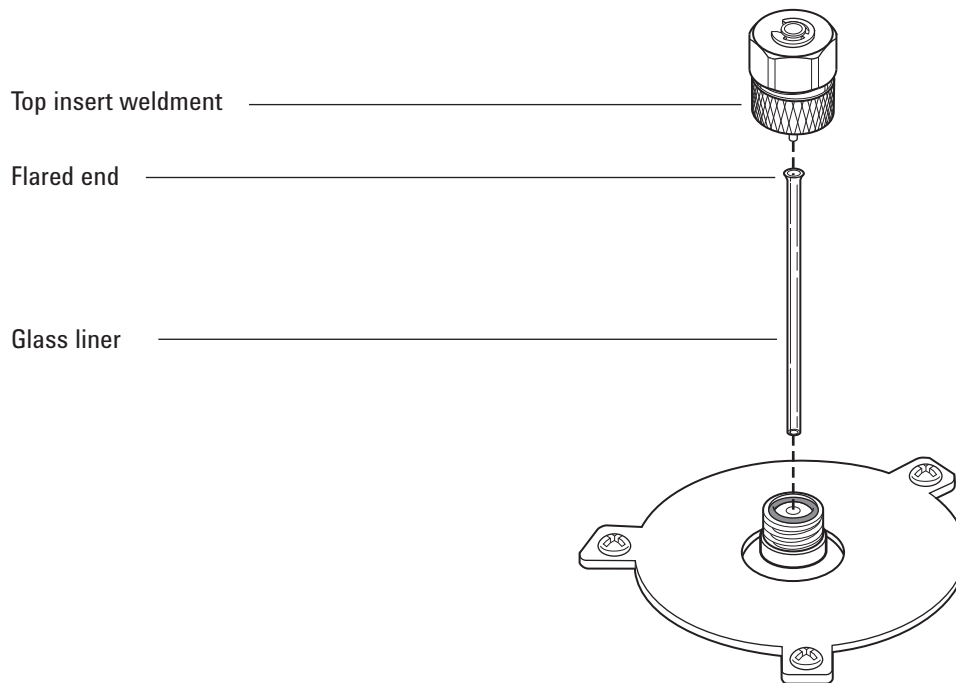

- 4 Use a thin wire or wood splint to carefully lift and remove the old glass liner.

**CAUTION**

**Wear clean, lint-free gloves to prevent contamination of parts with dirt and skin oils.**

---

- 5 Wearing gloves, inspect the O-ring and replace, if necessary. (See [“To Change the O-Ring on the Purged Packed Inlet”](#) on page 83.)
- 6 Wearing gloves, grasp the flared end (top) of the replacement glass liner with tweezers and install it in the inlet. If the glass liner does not seat properly because a capillary column is installed, remove the column, install the glass liner, and replace the column. (See [“To Install a Capillary Column with the Purged Packed Inlet”](#) on page 72.)
- 7 Install the top insert weldment and hand-tighten firmly.
- 8 Restore the analytical method.
- 9 Configure the new liner. If using the optional barcode scanner, scan the liner directly into your data system software configuration, then download the changes to the GC.
- 10 Reset the EMF counter. See [To Reset an EMF Counter](#) in the *Operation Manual*.

## To Install an Insulation Cup on the Purged Packed Inlet

- 1 Gather the following:
  - No-hole ferrule
  - Column nut
- 2 Install a plug (for example, a column nut with no-hole ferrule) in the inlet capillary adapter.

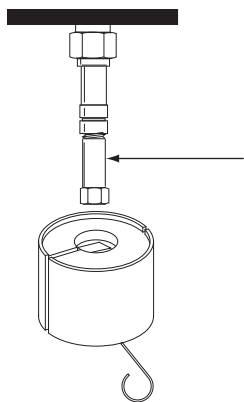

- 3 Push the cup spring to the right. Slide the cup over the inlet fitting so that the insulation at the top of the cup is flush against the oven roof.

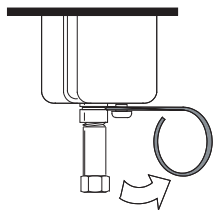

- 4 Place the spring into the groove in the inlet liner. Remove the column nut and no-hole ferrule.

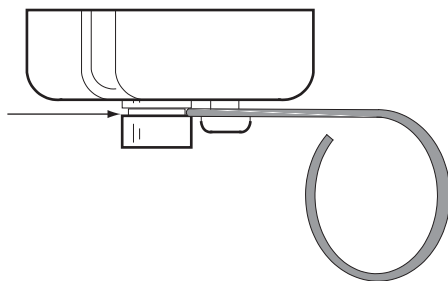

## To Clean the Purged Packed Inlet

- 1 Gather the following:
  - Replacement O-ring (See “Consumables and Parts for the Purged Packed Inlet” on page 68.)
  - Replacement glass liner
  - Replacement septum
  - Solvent that will clean the type of deposits in your inlet
  - Compressed, filtered, dry air or nitrogen
  - Beaker
  - Cleaning brushes—The FID cleaning kit (part number 9301-0985) contains appropriate brushes
  - Lint-free gloves
- 2 Load the [inlet maintenance method](#) and wait for the GC to become ready.

**WARNING**

**Be careful! The oven and/or inlet may be hot enough to cause burns. If the inlet is hot, wear heat-resistant gloves to protect your hands.**

---

- 3 Remove the column.
- 4 Remove the septum nut and septum.
- 5 Remove the top insert weldment.
- 6 Remove the glass liner and O-ring.
- 7 If used, remove the adapter.
- 8 Ultrasonically clean the septum nut, top insert weldment, and adapter (if used) in a suitable solvent.
- 9 Place a beaker in the oven under the inlet to catch the solvent.

**CAUTION**

Wear clean, lint-free gloves to prevent contamination of parts with dirt and skin oils.

---

- 10 Soak a cleaning brush with the solvent and vigorously scrub the interior walls of the inlet.

- 11 Blow the inside of the inlet dry with compressed air or nitrogen.
- 12 Install the adapter, if used. (See [“To Install an Adapter on the Purged Packed Inlet”](#) on page 81.)
- 13 Install the glass liner and O-ring. (See [“To Change the Glass Liner on the Purged Packed Inlet”](#) on page 84.)
- 14 Install the top insert weldment and finger-tighten.
- 15 Install the septum and septum nut. (See [“To Change the Septum on the Purged Packed Inlet”](#) on page 77.)
- 16 Attach the column. (See [“To Install a Capillary Column with the Purged Packed Inlet”](#) on page 72.)
- 17 Check for leaks.
- 18 Restore the analytical method.
- 19 Set the septum and glass liner counters.



## To Bakeout Contaminants from the Purged Packed Inlet

- 1 Set the column flow to the normal operating value, or set the capillary column gas velocity to 30 cm/s.
- 2 Purge the column with carrier flow for at least 10 minutes before heating the oven.
- 3 If the column is attached to the detector, set the detector 25 °C above normal operating temperature.

If the column is not attached to the detector, cap the detector fitting.

- 4 Set the inlet temperature to 300 °C or 25 °C above the normal operating temperature.
- 5 Set the column oven 25 °C above the GC method final oven temperature to bake contaminants out of the inlet. Do not exceed the column manufacturer's maximum temperature limit.
- 6 Bakeout for 30 minutes or until the detector baseline is free of contamination peaks.

## To Install a Packed Metal Column

- 1 Gather the following:
  - 7/16-inch, 9/16-inch, and 1/2-inch wrenches
  - Lint-free gloves
- 2 Load the [GC maintenance method](#) and wait for the GC to become ready.
- 3 Prepare the packed metal column. (See [“To Install Ferrules on a Packed Metal Column”](#) on page 99.)

### WARNING

**Be careful! The oven, inlet, and/or detector may be hot enough to cause burns. If the oven, inlet, or detector is hot, wear heat-resistant gloves to protect your hands.**

---

- 4 Install the 1/8-inch or 1/4-inch packed column inlet adapter, if necessary. (See [“To Install an Adapter on the Purged Packed Inlet”](#) on page 81.)

### CAUTION

Wear clean, lint-free gloves to prevent contamination of parts with dirt and skin oils.

---

- 5 Attach the column to the inlet adapter. Finger-tighten the nut.
- 6 Tighten the nut an additional 1/4 turn with a wrench (for a 1/8-inch column) or an additional 3/4 turn (for a 1/4-inch column).

Use two wrenches, one on the column nut and the other on the adapter, to prevent the adapter from rotating.

- 7 Press **[Config]**, **[Column 1]** or **[Column 2]**, enter **0.00** in either **Length** or **Diameter**, and identify the inlet and detector to which the column is attached.

### WARNING

**Do not use hydrogen as the carrier for conditioning! It could vent into the oven and present an explosion hazard.**

---

- 8 Condition the column, if necessary. (See [“To Condition a Packed Column”](#) on page 97.)

- 9 Load the [GC maintenance method](#) and wait for the GC to become ready.

**WARNING**

**Be careful! The oven, inlet, and/or detector may be hot enough to cause burns. If the oven, inlet, or detector is hot, wear heat-resistant gloves to protect your hands.**

---

- 10 If required, install the detector adapter. (See “[To Install a Packed Column Adapter on a Detector Fitting](#)” on page 92.)
- 11 Attach the column to the detector or detector adapter. Finger-tighten the nut.
- 12 Tighten the nut an additional 1/4 turn with a wrench (for a 1/8-inch column) or an additional 3/4 turn (for a 1/4-inch column).
- 13 Establish a flow of carrier gas and purge as recommended by the packing manufacturer. Generally:
  - 20 to 30 mL/min for 2-mm id glass or 1/8-inch od metal columns
  - 50 to 60 mL/min for 4-mm id glass or 1/4-inch od metal columns
- 14 Restore the analytical method.
  - For FPD, immediately turn off the flame.
  - For NPD, immediately set the bead voltage to 0.0.
- 15 After the GC becomes ready, wait 10 minutes then ignite the detector flame or adjust offset on the NPD bead.

**WARNING**

**Be careful! The oven, inlet, and/or detector may be hot enough to cause burns. If the oven, inlet, or detector is hot, wear heat-resistant gloves to protect your hands.**

---

- 16 Allow the oven, inlet, and detector to equilibrate at operating temperature, then retighten the fittings.

## To Install a Packed Column Adapter on a Detector Fitting

- 1 Gather the following:
  - 7/16-inch, 9/16-inch, and 1/2-inch wrenches
  - Vespel/graphite ferrule (See [“Consumables and Parts for the Purged Packed Inlet”](#) on page 68.)
  - Brass column nut
  - Lint-free gloves
  - Adapter.

Select the appropriate adapter from one of the parts lists shown below:

- [Consumables and Parts for the FID](#) (Packed columns can only be installed on an adaptable FID.)
  - [Consumables and Parts for the TCD](#)
  - [Consumables and Parts for the NPD](#)
  - [Consumables and Parts for the FPD](#)
  - For uECD, 1/4-inch packed columns require no adapter. For 1/8-inch packed columns, see [Consumables and Parts for the uECD](#).
- 2 Load the [GC maintenance method](#) and wait for the GC to become ready.

---

**WARNING**

**Be careful! The detector may be hot enough to cause burns. If the detector is hot, wear heat-resistant gloves to protect your hands.**

---

**CAUTION**

Wear clean, lint-free gloves to prevent contamination of parts with dirt and skin oils.

- 3 Assemble a nut and a ferrule onto the adapter.

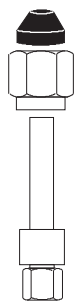

- 4 Insert the adapter straight into the detector base as far as possible.

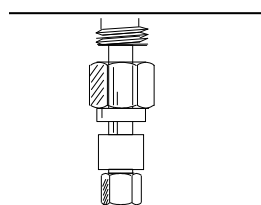

- 5 Hold the adapter in this position and finger-tighten the nut.
- 6 Tighten an additional 1/4 turn with a wrench (for a 1/8-inch column) or an additional 3/4 turn (for a 1/4-inch column).

## To Install a Packed Glass Column

- 1 Gather the following:
  - 9/16-inch wrench
  - Two 1/4-inch brass nuts (See “Consumables and Parts for the Purged Packed Inlet” on page 68.)
  - Two 1/4-inch Vespel/graphite ferrules
  - Lint-free gloves
- 2 Load the [GC maintenance method](#) and wait for the GC to become ready.

### WARNING

**Be careful! The oven, inlet, and/or detector may be hot enough to cause burns. If the oven, inlet, or detector is hot, wear heat-resistant gloves to protect your hands.**

---

### CAUTION

Wear clean, lint-free gloves to prevent contamination of parts with dirt and skin oils.

---

- 3 Assemble a brass nut and Vespel/graphite ferrule on each end of the column.



Glass columns must be simultaneously inserted into the inlet and detector and installed parallel to the oven door. When conditioning the column, do not attach the column to the detector.

- 4 If conditioning the column, insert the column into the purged packed inlet until it bottoms. Withdraw the column 1 to 2 mm. Finger-tighten the inlet column nut. (See “[To Condition a Packed Column](#)” on page 97.)

### CAUTION

Overtightening the column nut or forcing it to bottom in either the inlet or detector may shatter the column.

---

5 Tighten the inlet column nut 1/4 turn with a wrench.

**WARNING**

**Do not use hydrogen as the carrier for conditioning! It could vent into the oven and present an explosion hazard.**

- 6 After conditioning, remove the column from the inlet.
- 7 Simultaneously insert the column into the inlet and detector fittings but *do not* force it. It may be necessary to start the long end of the column in the inlet at an angle to clear the oven floor.

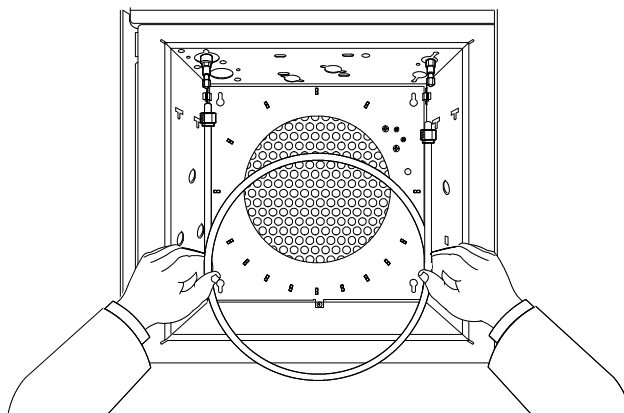

8 Withdraw the column 1 to 2 mm from both the inlet and detector. Finger-tighten both column nuts.

**CAUTION**

Overtightening the column nut or forcing it to bottom in either the inlet or detector may shatter the column.

- 9 Tighten both column nuts 1/4 turn with a wrench.
- 10 Press **[Config]**, **[Column 1]** or **[Column 2]**, enter **0.00** in either **Length** or **Diameter**, and identify the inlet and detector to which the column is connected.
- 11 Establish a flow of carrier gas and purge as recommended by the packing manufacturer. Generally:
- 20 to 30 mL/min for 2-mm id glass or 1/8-inch od metal columns
  - 50 to 60 mL/min for 4-mm id glass or 1/4-inch od metal columns
- 12 Restore the analytical method.
- For FPD, immediately turn off the flame.

## 6 Maintaining the Purged Packed Inlet

- For NPD, immediately set the bead voltage to 0.0.
- 13 After the GC becomes ready, wait 10 minutes then ignite the detector flame or adjust offset on the NPD bead.

### **WARNING**

**Be careful! The oven, inlet, and/or detector may be hot enough to cause burns. If the oven, inlet, or detector is hot, wear heat-resistant gloves to protect your hands.**

---

- 14 Allow the oven, inlet, and detector to equilibrate at operating temperature, then retighten the fittings.



## To Condition a Packed Column

- 1 Gather the following:
  - Capillary adapter, column nut, and no-hole ferrule (for FID and NPD), or 1/8-inch Swagelok cap (for TCD and FPD)
  - Two 7/16-inch wrenches
  - 1/4-inch open-end wrench
  - Lint-free gloves

**WARNING**

**Do not use hydrogen as the carrier for conditioning! It could vent into the oven and present an explosion hazard.**

---

- 2 Load the [GC maintenance method](#) and wait for the GC to become ready.

**WARNING**

**Be careful! The oven, inlet, and/or detector may be hot enough to cause burns. If the oven, inlet, or detector is hot, wear heat-resistant gloves to protect your hands.**

---

**CAUTION**

Wear clean, lint-free gloves to prevent contamination of parts with dirt and skin oils.

---

- 3 Install the proper liner in the inlet and attach the column. (See [“To Install a Packed Metal Column”](#) on page 90.)
- 4 Cap the detector(s) fittings with the capillary adapter, no-hole ferrule and column nut (FID and NPD) or 1/8-inch cap (FPD and TCD).
- 5 Enter a column flow as recommended by the packing manufacturer or an appropriate flow as follows:
  - 20 to 30 mL/min for 2-mm id glass or 1/8-inch od metal columns
  - 50 to 60 mL/min for 4-mm id glass or 1/4-inch od metal columns
- 6 Raise the oven temperature slowly to the conditioning temperature for the column. The conditioning temperature

## 6 Maintaining the Purged Packed Inlet

is never higher than the maximum temperature limit for the column; 30 °C less than the maximum is usually sufficient.

- 7 Continue conditioning overnight at the final temperature. Cool the oven to room temperature with carrier flow on.
- 8 Attach the column to the detector and maintain established flow. (See [“To Install a Packed Metal Column”](#) on page 90.)

## To Install Ferrules on a Packed Metal Column

- 1 Gather the following:
  - Wrenches
  - Stainless steel male Swagelok fitting, 1/4- or 1/8-inch od
  - Brass Swagelok nut and ferrule set (See “Consumables and Parts for the Purged Packed Inlet” on page 68.)
  - Lint-free gloves
- 2 Verify that the column end is cut square and is free of burns and deformation.
- 3 Secure the fitting in a bench vise.

### CAUTION

Wear clean, lint-free gloves to prevent contamination of parts with dirt and skin oils.

- 4 Assemble a Swagelok nut and ferrules onto the column.

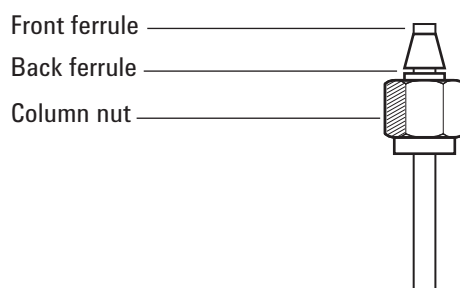

- 5 Fully insert the column into the vise-held fitting, then withdraw 1–2 mm. Finger-tighten the nut.
- 6 Tighten the nut an additional 3/4 turn with a wrench (for a 1/8-inch column) or an additional 1-1/4 turn (for a 1/4-inch column).
- 7 Unscrew the column nut from the vise-held fitting and remove the column. Ferrules should now be set in place on the column with the column end correctly positioned.

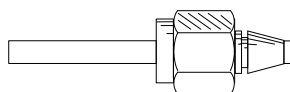

## **6 Maintaining the Purged Packed Inlet**

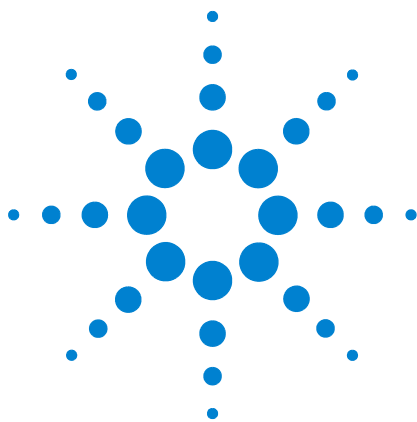

## 7 Maintaining the COC Inlet

- Consumables and Parts for the COC Inlet [102](#)
- Exploded Parts View of the COC Inlet [106](#)
- To Install a Capillary Column with the COC Inlet [107](#)
- To Check the Needle-to-Column Size on the COC Inlet [110](#)
- To Change a Septum on the COC Inlet [112](#)
- To Install an Insert on the COC Inlet [114](#)
- To Clean the COC Inlet [116](#)
- To Replace the 7693A Injector Needle Support Guide [118](#)
- To Replace the Needle Support Assembly in a 7683B Injector [119](#)
- To Replace a Needle in a Syringe [122](#)
- To Replace the Fused Silica Needle in a Syringe for the COC Inlet [123](#)
- To Bakeout Contaminants from the COC Inlet [125](#)



## Consumables and Parts for the COC Inlet

See the Agilent catalog for consumables and supplies for a more complete listing, or visit the Agilent Web site for the latest information ([www.agilent.com/chem/supplies](http://www.agilent.com/chem/supplies)).

**Table 12** Recommended parts for injections onto 0.53-mm fused silica columns

Column type	Part number
Insert, fused silica, 0.53-mm id	19245-20580 (no rings)
Septum nut, 530 $\mu$ m	G1545-80520
Syringe barrel, removable needle, 5 $\mu$ L	5182-0836
Needle, 530 $\mu$ m (3/pk)	5182-0832
Plunger button, 10/pk, for manual injections using syringe barrel 5182-0836	5181-8866
On-column insert spring	19245-60760
Needle support assembly, 530 $\mu$ m, for 7683B injector	G2913-60977

**Table 13** Recommended parts for injections onto 0.53-mm aluminum-clad columns

Column type	Part number
Insert, aluminum-clad, 0.53-mm id	19245-20780 (4 rings)
Septum nut, 530 $\mu$ m	G1545-80520
Syringe barrel, removable needle, 5 $\mu$ L	5182-0836
Needle, 530 $\mu$ m (3/pk)	5182-0832
Plunger button, 10/pk, for manual injections using syringe barrel 5182-0836	5181-8866
On-column insert spring	19245-60760
Needle support assembly, 530 $\mu$ m, for 7683B injector	G2913-60977

**Table 14** Recommended parts for injections onto 0.32-mm fused silica columns

Column type	Part number
Insert, fused silica, 0.32-mm id	19245-20525 (5 rings)
Septum nut, 250/320 $\mu$ m	19245-80521
Syringe barrel, removable needle, 5 $\mu$ L	5182-0836
Needle, 320 $\mu$ m (3/pk)	5182-0831
Plunger button, 10/pk, for manual injections using syringe barrel 5182-0836	5181-8866
On-column insert spring	19245-60760
Needle support assembly, 250/320 $\mu$ m, for 7683B injector	G2913-60978

**Table 15** Recommended parts for injections onto 0.25-mm fused silica columns

Column type	Part number
Insert, 0.25-mm id	19245-20515 (6 rings)
Septum nut, 250/320 $\mu$ m	19245-80521
Syringe barrel, removable needle, 5 $\mu$ L	5182-0836
Needle, 250 $\mu$ m (3/pk)	5182-0833
Plunger button, 10/pk, for manual injections using syringe barrel 5182-0836	5181-8866
On-column insert spring	19245-60760
Needle support assembly, 250/320 $\mu$ m, for 7683B injector	G2913-60978

**Table 16** Recommended parts for injections onto 0.2-mm fused silica columns

Description	Part number/quantity
Insert, fused silica, 0.20-mm id	19245-20510
Cooling tower assembly	19320-80625
Syringe barrel, for fused silica needle, 10 $\mu$ L	9301-0658
Replacement needles, fused silica, 0.18 mm	19091-63000 (6/pk)

**Table 16** Recommended parts for injections onto 0.2-mm fused silica columns (continued)

Description	Part number/quantity
Replacement PTFE ferrule for fused silica syringe	0100-1389
Removable stainless steel needle syringe, 10 $\mu$ L	5182-9633
Replacement stainless steel needles, 0.23 mm	5182-9645 (3/pk)
On-column insert spring	19245-60760

**Table 17** Recommended septa for the COC inlet

Description	Part number/quantity
<b>For 0.53-mm and 0.25/0.32-mm septum nuts</b>	
5-mm solid septum for manual and automatic injection	5181-1261
5-mm long-life septum	5183-4762 (50/pk)
5-mm advanced green septum	5183-4760 (50/pk)
5-mm, high-temperature, low-bleed septum	5183-4758 (50/pk)
5-mm through-hole septum for automatic injection	5181-1260 (25/pk)
<b>For the duckbill septum</b>	
Duckbill septum for manual injection only (must use cooling tower with duckbill)	19245-40050 (10/pk)

**Table 18** Nuts, ferrules, and hardware for capillary columns

Column id (mm)	Description	Typical use	Part number/quantity
.530	Ferrule, Vespel/graphite, 0.8-mm id	0.45-mm and 0.53-mm capillary columns	5062-3512 (10/pk)
	Ferrule, graphite, 1.0-mm id	0.53-mm capillary columns	5080-8773 (10/pk)
	Ferrule, graphite, 0.8-mm id	0.53-mm capillary columns	500-2118 (10/pk)
	Column nut, finger-tight (for 0.53-mm columns)	Connect column to inlet or detector	5020-8293



**Table 18** Nuts, ferrules, and hardware for capillary columns (continued)

Column id (mm)	Description	Typical use	Part number/quantity
.320	Ferrule, Vespel/graphite, 0.5-mm id	0.32-mm capillary columns	5062-3514 (10/pk)
	Ferrule, graphite, 0.5-mm id	0.1-mm, 0.2-mm, 0.25-mm, and 0.32-mm capillary columns	5080-8853 (10/pk)
	Column nut, finger-tight (for .100- to .320-mm columns)	Connect column to inlet or detector	5020-8292
.250	Ferrule, Vespel/graphite, 0.4-mm id	0.1-mm, 0.2-mm, and 0.25-mm capillary columns	5181-3323 (10/pk)
	Ferrule, graphite, 0.5-mm id	0.1-mm, 0.2-mm, 0.25-mm, and 0.32-mm capillary columns	5080-8853 (10/pk)
	Column nut, finger-tight (for .100- to .320-mm columns)	Connect column to inlet or detector	5020-8292
.100 and .200	Ferrule, Vespel/graphite, 0.37-mm id	0.1-mm and 0.2-mm capillary columns	5062-3516 (10/pk)
	Ferrule, Vespel/graphite, 0.4-mm id	0.1-mm, 0.2-mm, and 0.25-mm capillary columns	5181-3323 (10/pk)
	Ferrule, graphite, 0.5-mm id	0.1-mm, 0.2-mm, 0.25-mm, and 0.32-mm capillary columns	5080-8853 (10/pk)
	Ferrule, graphite, 0.4-mm id		500-2114 (10/pk)
	Column nut, finger-tight (for .100- to .320-mm columns)	Connect column to inlet or detector	5020-8292
All	Ferrule, no-hole	Testing	5181-3308 (10/pk)
	Capillary column blanking nut	Testing—use with any ferrule	5020-8294
	Column nut, universal	Connect column to inlet or detector	5181-8830 (2/pk)
	Column cutter, ceramic wafer	Cutting capillary columns	5181-8836 (4/pk)
	Pencil, diamond tipped	Cutting capillary columns	420-1000
	Ferrule tool kit	Ferrule installation	440-1000

## Exploded Parts View of the COC Inlet

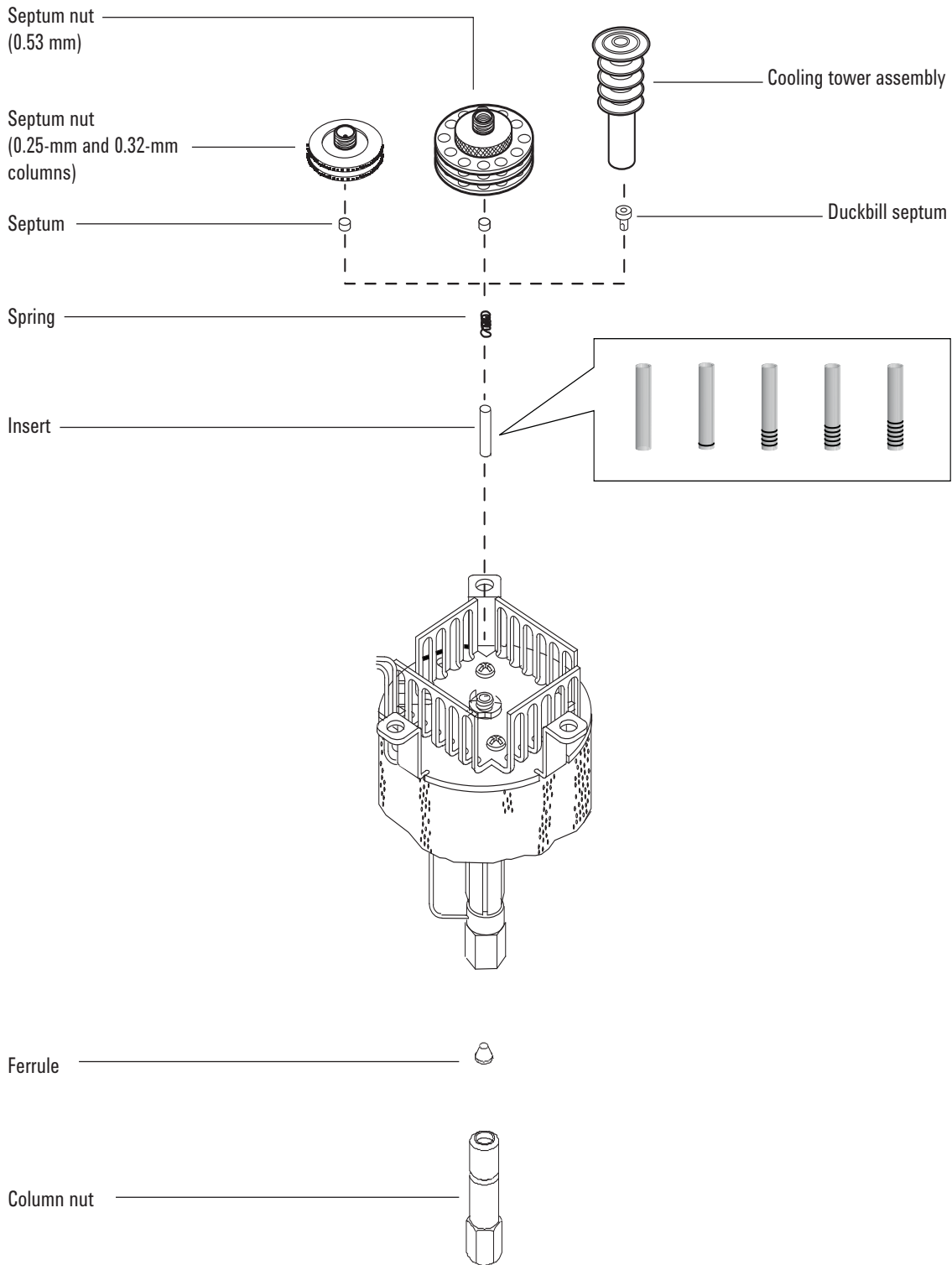

## To Install a Capillary Column with the COC Inlet

- 1 Gather the following:
  - Column nut and ferrule. (See [“Consumables and Parts for the COC Inlet”](#) on page 102.)
  - Column cutter
  - 1/4-inch and 5/16-inch wrenches
  - Lint-free gloves
- 2 Load the [inlet maintenance method](#) and wait for the GC to become ready.

### WARNING

**Be careful! The oven and/or inlet may be hot enough to cause burns. If either is hot, wear heat-resistant gloves to protect your hands.**

### WARNING

**Wear safety glasses to protect your eyes from flying particles while handling, cutting, or installing glass or fused silica capillary columns. Use care in handling these columns to prevent puncture wounds.**

### CAUTION

Wear clean, lint-free gloves to prevent contamination of parts with dirt and skin oils.

- 3 Before installing the column, be sure the correct insert is installed for the needle and column. (See [“To Install an Insert on the COC Inlet”](#) on page 114.)
- 4 Place a capillary column nut and ferrule on the column.

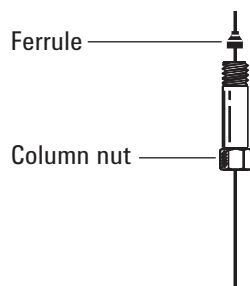

- 5 Score the column using a glass scribing tool. The score must be square to ensure a clean break.

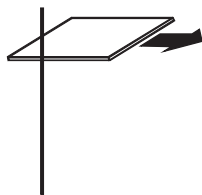

- 6 Break off the column end by supporting it against the column cutter opposite the scribe. Inspect the end with a magnifying loupe to make certain there are no burrs or jagged edges.

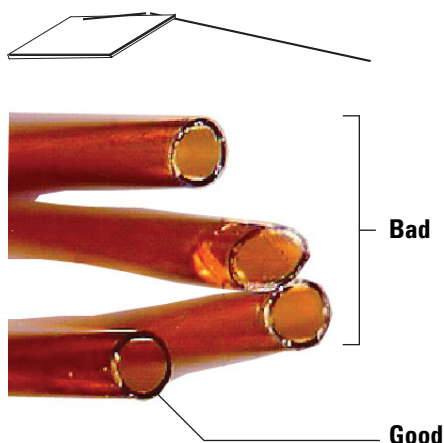

- 7 Wipe the column walls with a tissue dampened with isopropanol to remove fingerprints and dust.
- 8 Gently insert the column into the inlet until it bottoms. You should feel spring tension as you push up on the column. (Do not withdraw the column.)
- 9 Insert the column nut into the inlet fitting and finger-tighten.

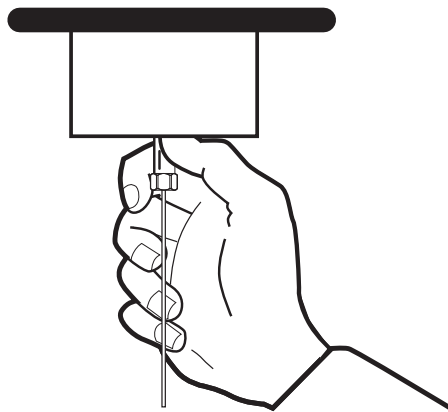

**WARNING**

**To avoid bending the inlet, always use two wrenches. Use a 5/16-inch wrench to support the inlet while tightening the column nut with a 1/4-inch wrench.**

---

- 10 Tighten the column nut an additional 1/4 turn with a wrench or until the column does not move.
- 11 If using an automatic injection system with a 0.25-mm or 0.32-mm column, verify that the column installation by manually pushing the syringe into the inlet.
- 12 Configure the new column. If using the optional barcode scanner, scan the column directly into your data system software configuration, then download the changes to the GC.
- 13 Condition the column per the manufacturer's recommendation. (See [To Condition a Capillary Column.](#))
- 14 Install the column into the detector. See:
  - [To Install a Capillary Column in the FID](#)
  - [To Install a Capillary Column in the NPD](#)
  - [To Install a Capillary Column in the TCD](#)
  - [To Install a Capillary Column in the uECD](#)
  - [To install a Capillary Column in the FPD Plus](#)
  - [To Install a Capillary Column Adapter in the FPD](#)
- 15 After the column is installed at both inlet and detector, establish a flow of carrier gas and purge as recommended by the column manufacturer.
- 16 Restore the analytical method.
  - For FPD, immediately turn off the flame.
  - For NPD, immediately set the bead voltage to 0.0.
- 17 After the GC becomes ready, wait 10 minutes then ignite the detector flame or adjust offset on the NPD bead.

**WARNING**

**Be careful! The oven, inlet, and/or detector may be hot enough to cause burns. If they are hot, wear heat-resistant gloves to protect your hands.**

---

- 18 Allow the oven, inlet, and detector to equilibrate at operating temperature, then retighten the fittings.
- 19 Reset the column EMF counters. See [To Reset an EMF Counter](#) in the *Operation Manual*.

## To Check the Needle-to-Column Size on the COC Inlet

- 1 Gather the following:
  - Insert (See [“Consumables and Parts for the COC Inlet”](#) on page 102.)
  - Syringe needle
- 2 Load the [inlet maintenance method](#) and wait for the GC to become ready.

**WARNING**

**Be careful! The oven and/or inlet may be hot enough to cause burns. If either is hot, wear heat-resistant gloves to protect your hands.**

---

**WARNING**

**Wear safety glasses to protect your eyes from flying particles while handling, cutting, or installing glass or fused silica capillary columns. Use care in handling these columns to prevent puncture wounds.**

---

- 3 Check that the needle is the correct size for the desired column id. If needed, replaced the needle with one of the correct size. See [“Consumables and Parts for the COC Inlet”](#) on page 102, and [“To Replace a Needle in a Syringe”](#) on page 122 or [“To Replace the Fused Silica Needle in a Syringe for the COC Inlet”](#) on page 123.
- 4 Identify the correct insert for the column size. (See [“Consumables and Parts for the COC Inlet”](#) on page 102.) Use the insert that is the same size as the syringe needle to verify that the column you plan to use is the correct size.
- 5 Make a clean cut on the end of the column. (See [“To Install a Capillary Column with the COC Inlet”](#) on page 107.)
- 6 Insert the column into one end of the insert.

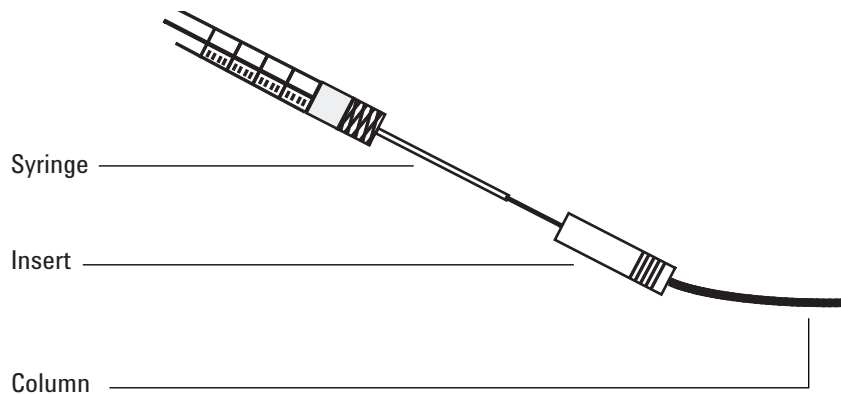

- 7 Insert the syringe needle through the other end of the insert and into the column. The needle should visibly enter the column without any obstruction. If the needle cannot pass easily into the column, reverse the insert to try the needle and column in the other end.

## To Change a Septum on the COC Inlet

- 1 Gather the following:
  - Replacement septum. (See “Consumables and Parts for the COC Inlet” on page 102.)
  - Tweezers
  - A thin wire (0.2-inch diameter) for removing septum from inlet
  - Lint-free gloves
- 2 Load the [inlet maintenance method](#) and wait for the GC to become ready.

### WARNING

**Be careful! The oven and/or inlet may be hot enough to cause burns. If either is hot, wear heat-resistant gloves to protect your hands.**

### CAUTION

Wear clean, lint-free gloves to prevent contamination of parts with dirt and skin oils.

- 3 Replace the septum.
  - If you are using a septum nut, grasp the knurling and unscrew. Remove the old septum with tweezers. Use tweezers to install a new septum. Push the septum into the septum nut until properly seated. Firmly tighten the nut.

For 250/320- $\mu\text{m}$   
automated injections

For 530- $\mu\text{m}$  automated  
injections

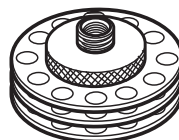



- If you are using a cooling tower, grasp the three rings and unscrew. The spring and duckbill septum may pop out of the inlet when you remove the cooling tower. Be careful not to lose them. If they do not pop out, use a thin wire to remove them from the inlet. Insert the replacement duckbill septum into the spring and place in the inlet. Reattach the cooling tower assembly, then finger-tighten.

For manual 200- $\mu\text{m}$  injections with fused silica needle

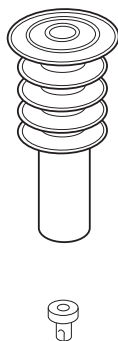

- 4 Before making an injection, check the alignment of the entire assembly using the proper size syringe.
- 5 Restore the analytical method.
- 6 Reset the septum EMF counter. See [To Reset an EMF Counter](#) in the *Operation Manual*.

## To Install an Insert on the COC Inlet

- 1 Gather the following:
  - Lint-free gloves
  - Replacement insert. (See [“Consumables and Parts for the COC Inlet”](#) on page 102.)
- 2 Load the [inlet maintenance method](#) and wait for the GC to become ready.

**WARNING**

**Be careful! The oven and/or inlet may be hot enough to cause burns. If either is hot, wear heat-resistant gloves to protect your hands.**

---

**CAUTION**

Wear clean, lint-free gloves to prevent contamination of parts with dirt and skin oils.

---

- 3 Remove the column from the inlet.
- 4 Locate the septum nut or cooling tower assembly at the top of the inlet and remove it. If the septum remains in the septum nut, do not remove it unless you want to change it. If necessary, replace the existing septum or duckbill with a new one. (See [“To Change a Septum on the COC Inlet”](#) on page 112.)
- 5 Remove the spring from the inlet with an extraction wire (or tweezers) and set it aside. Be careful not to lose or damage it because you will use the spring to keep the new insert in position.

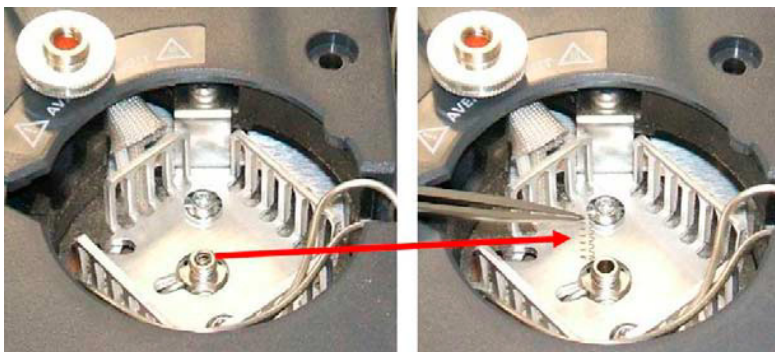

- 6 Remove the existing insert from the inlet by gently pushing it out from below with a wire or piece of column. Store the insert for possible later use.



- 7 Check that the insert is the correct size for both the needle and column. (See [“To Check the Needle-to-Column Size on the COC Inlet”](#) on page 110.)
- 8 Lower the new insert straight into the inlet from the top. The insert can be installed either end up.
- 9 Install the spring on top of the insert.
- 10 Install the septum and septum nut or duckbill septum and cooling tower assembly and finger-tighten.
- 11 Install the column. (See [“To Install a Capillary Column with the COC Inlet”](#) on page 107.)

## To Clean the COC Inlet

- 1 Gather the following:
  - 1/4-inch and 5/16-inch wrenches
  - Cleansing bath
  - Aqueous detergent
  - Distilled water
  - Methanol
  - Compressed, filtered, dry air or nitrogen
  - Lint-free gloves
- 2 Load the [inlet maintenance method](#) and wait for the GC to become ready.

---

**WARNING**

**Be careful! The oven and/or inlet may be hot enough to cause burns. If either is hot, wear heat-resistant gloves to protect your hands.**

---

**WARNING**

**Wear safety glasses to protect your eyes from flying particles while handling, cutting, or installing glass or fused silica capillary columns. Use care in handling these columns to prevent puncture wounds.**

---

**CAUTION**

Wear clean, lint-free gloves to prevent contamination of parts with dirt and skin oils.

---

- 3 Remove the column.
- 4 Remove the septum nut or cooling tower and then remove the septum.
- 5 Remove the existing insert from the inlet by gently pushing it out from below with a wire or piece of column. Store the insert for possible later use.

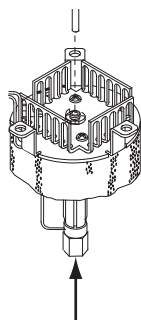

- 6 Fill an ultrasonic cleansing bath with aqueous detergent and place the spring and insert into it. Sonicate for 1 minute.
- 7 Drain the aqueous detergent and fill the bath with distilled water. Sonicate for 1 minute.
- 8 Remove the spring and insert from the bath and rinse thoroughly with water and methanol.
- 9 Dry the spring and insert with compressed air or nitrogen.
- 10 Install the insert. (See [“To Install an Insert on the COC Inlet”](#) on page 114.)
- 11 Install the column. (See [“To Install a Capillary Column with the COC Inlet”](#) on page 107.)

## To Replace the 7693A Injector Needle Support Guide

Before using a 7693A ALS to make injections onto the COC inlet, install the on-column needle support guide.

Refer to the [7693A ALS documentation](#) for complete details.

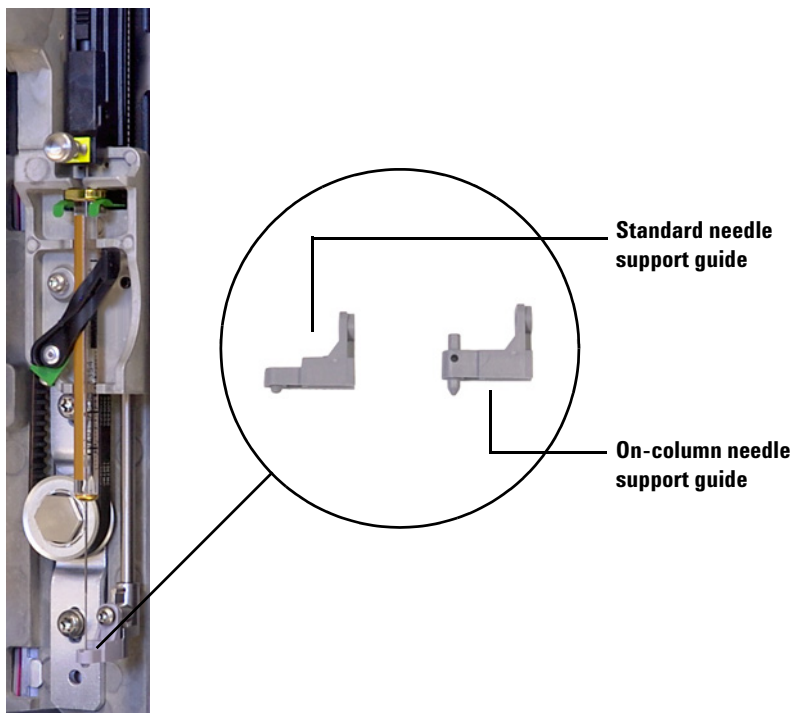

- 1 Open the injector door.
- 2 Remove the syringe.
- 3 Slide the syringe carriage up to the top position.
- 4 Completely remove the T-10 Torx screw from the support foot. Be careful to not let the screw fall into the turret assembly.
- 5 Slide off the support foot.
- 6 Slide on the new support foot.
- 7 Replace the T-10 Torx screw and tighten.
- 8 Install the appropriate syringe.
- 9 Close the injector door.
- 10 Align the injector.

## To Replace the Needle Support Assembly in a 7683B Injector

- 1 Gather a 7683B needle support assembly for injections onto 530- $\mu\text{m}$  or 250/320- $\mu\text{m}$  columns.



250  $\mu\text{m}$ /320  $\mu\text{m}$   
(G2913-60978)



530  $\mu\text{m}$   
(standard, G2913-60978)

- 2 Remove all vials and bottles from the turret, and disconnect the injector cable from the GC.
- 3 Open the injector door.
- 4 Remove the syringe.
- 5 With your finger under the shaft near the bearing on the needle support assembly, pull gently to release the bearing from the bearing clip in the syringe carriage.

## 7 Maintaining the COC Inlet

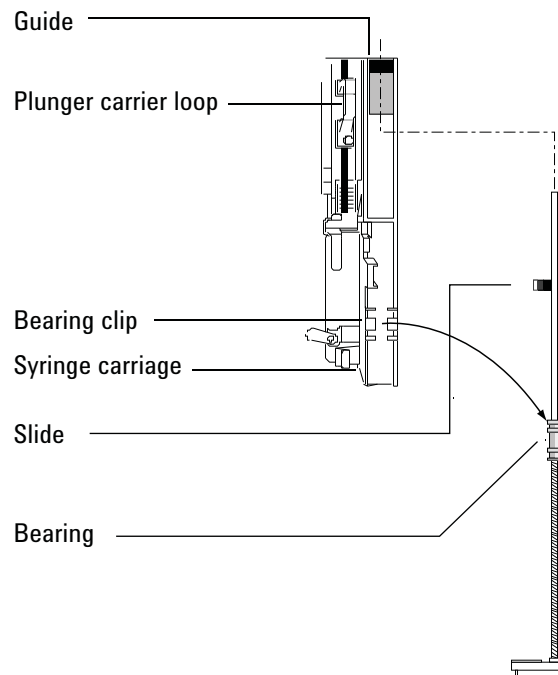

### CAUTION

Do not pull the assembly by its metal shaft, as it is easily bent.

- 6 Carefully use the bearing to pull the rod down until you can lift the assembly out of the syringe carriage.
- 7 To install the needle support assembly, use your right hand to insert the upper end of the rod into the plastic guide to the right of the plunger carrier loop.



- 8 Turn the needle support assembly so that the flat surface of the slide glides up and down the syringe carriage tracks.

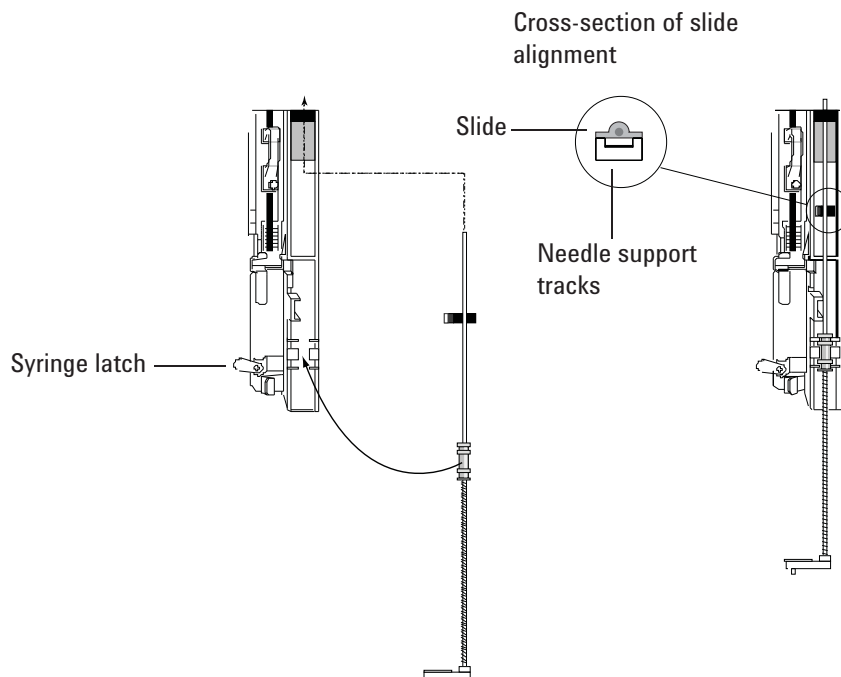

- 9 Align the bearing on the needle support assembly with the plastic bearing clip to the right of the syringe latch and push gently on the bearing until the assembly snaps into place.

**CAUTION**

Be careful not to bend the needle during installation.

Do not operate the injector without a syringe or align the probe in place because the free-swinging syringe latch may interfere with the motor and jam the syringe carriage.

- 10 Install the syringe.

## To Replace a Needle in a Syringe

- 1 Gather the following (see Table 15, “Recommended parts for injections onto 0.25-mm fused silica columns,” on page 103):
  - Syringe barrel
  - Needle, 250- $\mu\text{m}$  or 320- $\mu\text{m}$
- 2 Unscrew the syringe barrel cap and remove the spring.
- 3 Make sure that the needle has the PTFE disk as shown below. If the syringe barrel does not have the PTFE disk, use the instructions in the syringe box to wrap the needle.

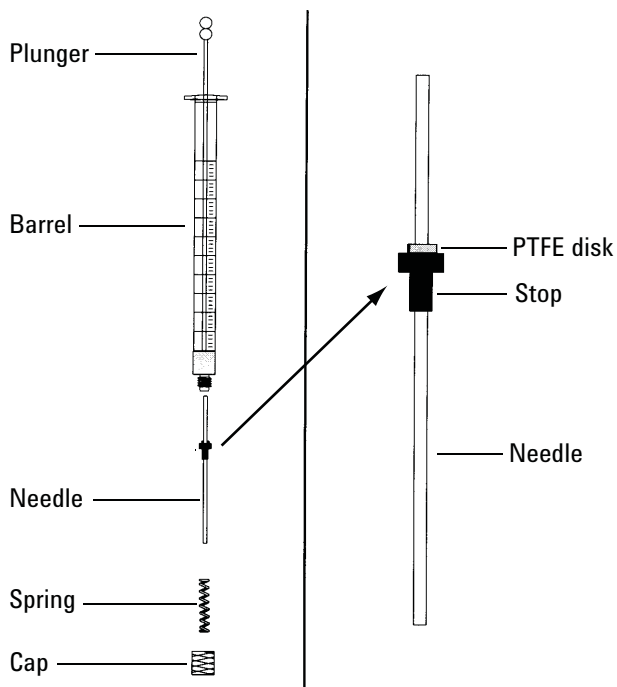

- 4 Check the new needle for a small wire inserted for shipment. Remove the wire if present.
- 5 Slide the spring and the cap over the needle.
- 6 Insert the needle into the syringe barrel.
- 7 Screw the cap back on the syringe barrel.

## To Replace the Fused Silica Needle in a Syringe for the COC Inlet

### NOTE

The fused silica needle and syringe are only used with the cooling tower and duckbill septum for manual, on-column injections onto 200- $\mu$ m columns.

- 1 Gather the following:
  - New fused silica syringe needle (See “Consumables and Parts for the COC Inlet” on page 102.)
  - Solvent

### WARNING

**Wear safety glasses to protect your eyes from flying particles while handling, cutting, or installing glass or fused silica capillary columns. Use care in handling these columns to prevent puncture wounds.**

- 2 Loosen the retaining nut and remove the old needle.
- 3 Hold the syringe vertically and insert the new fused silica needle so it is visible inside the syringe barrel. If the needle cannot be inserted into the syringe barrel, the PTFE ferrule may be blocked. You may need to replace the ferrule.
- 4 Push the plunger down until it bottoms. The needle will be flush with the plunger end.

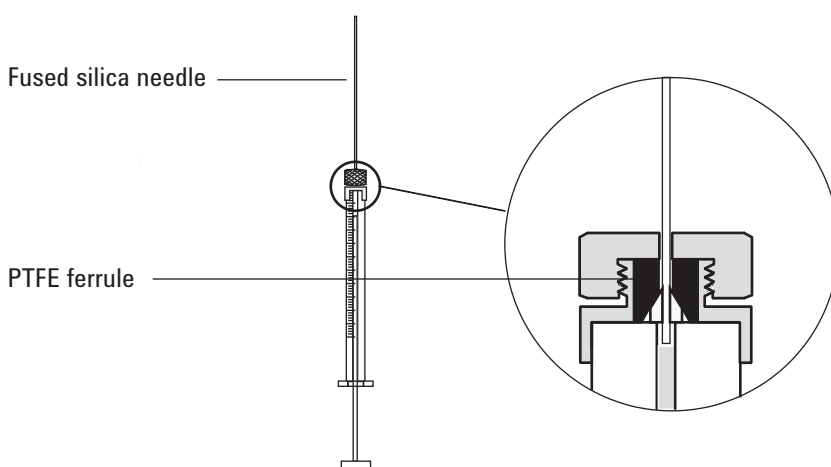

- 5 Finger-tighten the retaining nut. Pull the needle gently to be sure the PTFE ferrule has formed a tight seal with the needle. Tighten the retaining nut further, if necessary.

## **7** Maintaining the COC Inlet

- 6** Loosen the retaining nut just enough so the needle is again free.
- 7** Depress the syringe plunger slowly until it pushes the needle to the end of the barrel, then finger-tighten the retaining nut.
- 8** Use a solvent to rinse the syringe and check for leaks or blocks. Leaks may be fixed by further tightening the retaining nut. Blocks or serious leaks require repeating this procedure.

## To Bakeout Contaminants from the COC Inlet

- 1 Set the column flow to the normal operating value, or set the capillary column gas velocity to 30 cm/s.
- 2 Purge the column with carrier flow for at least 10 minutes before heating the oven.
- 3 Set the inlet mode to **Oven Track**.
- 4 If the column is attached to the detector, set the detector 25 °C above normal operating temperature.

If the column is not attached to the detector, cap the detector fitting.

- 5 Set the column oven 25 °C above the GC method final oven temperature to bake contaminants out of the inlet. Do not exceed the column manufacturer's maximum temperature limit.
- 6 Bakeout for 30 minutes or until the detector baseline is free of contamination peaks.

## **7 Maintaining the COC Inlet**



## 8 Maintaining the MMI

- Consumables and Parts for the MMI 128
- Exploded Parts View of the MMI 131
- To Install the Column Nut Adapter 132
- To Install a Capillary Column with the MMI 133
- To Change the Septum on the MMI 137
- To Clean the Septum Seat in the Insert Assembly of the MMI 139
- To Change the Liner and O-Ring on the MMI 141
- To Replace the Filter in the Split Vent Line for the MMI 144
- To Clean the Multimode Inlet 147
- To Bakeout Contaminants from the MMI 149



## Consumables and Parts for the MMI

See the Agilent catalog for consumables and supplies for a more complete listing, or visit the Agilent Web site for the latest information ([www.agilent.com/chem/supplies](http://www.agilent.com/chem/supplies)).

**Table 19** Split, splitless, direct, and direct connect inlet liners

Mode	Description	Deactivated	Part number
Split	Low-pressure drop, glass wool, single taper, 870 $\mu$ L	Yes	5183-4647
Split	Glass wool, 990 $\mu$ L	No	19251-60540
Split—Manual only	Empty pin and cup, 800 $\mu$ L	No	18740-80190
Split—Manual only	Packed pin and cup, 800 $\mu$ L	No	18740-60840
Splitless	Single taper, glass wool, 900 $\mu$ L	Yes	5062-3587
Splitless	Single taper, no glass wool, 900 $\mu$ L	Yes	5181-3316
Splitless	Dual taper, no glass wool, 800 $\mu$ L	Yes	5181-3315
Splitless—Direct inject	2-mm id, quartz, 250 $\mu$ L	No	18740-80220
Splitless—Direct inject	2-mm id, 250 $\mu$ L	Yes	5181-8818
Direct inject —Headspace or purge and trap	1.5-mm id, 140 $\mu$ L	No	18740-80200
Direct column connect	Single taper, splitless 4-mm id	Yes	G1544-80730
Direct column connect	Dual taper, splitless 4-mm id	Yes	G1544-80700

**Table 20** Nuts, ferrules, and hardware for capillary columns

Column id (mm)	Description	Typical use	Part number/quantity
.530	Ferrule, Vespel/graphite, 0.8-mm id	0.45-mm and 0.53-mm capillary columns	5062-3512 (10/pk)
	Ferrule, graphite, 1.0-mm id	0.53-mm capillary columns	5080-8773 (10/pk)
	Ferrule, graphite, 0.8-mm id	0.53-mm capillary columns	500-2118 (10/pk)
	Column nut, finger-tight (for 0.53-mm columns)	Connect column to inlet or detector	5020-8293
.320	Ferrule, Vespel/graphite, 0.5-mm id	0.32-mm capillary columns	5062-3514 (10/pk)
	Ferrule, graphite, 0.5-mm id	0.1-mm, 0.2-mm, 0.25-mm, and 0.32-mm capillary columns	5080-8853 (10/pk)
	Column nut, finger-tight (for .100- to .320-mm columns)	Connect column to inlet or detector	5020-8292



**Table 20** Nuts, ferrules, and hardware for capillary columns (continued)

Column id (mm)	Description	Typical use	Part number/quantity
.250	Ferrule, Vespel/graphite, 0.4-mm id	0.1-mm, 0.2-mm, and 0.25-mm capillary columns	5181-3323 (10/pk)
	Ferrule, graphite, 0.5-mm id	0.1-mm, 0.2-mm, 0.25-mm, and 0.32-mm capillary columns	5080-8853 (10/pk)
	Column nut, finger-tight (for .100- to .320-mm columns)	Connect column to inlet or detector	5020-8292
.100 and .200	Ferrule, Vespel/graphite, 0.37-mm id	0.1-mm and 0.2-mm capillary columns	5062-3516 (10/pk)
	Ferrule, Vespel/graphite, 0.4-mm id	0.1-mm, 0.2-mm, and 0.25-mm capillary columns	5181-3323 (10/pk)
	Ferrule, graphite, 0.5-mm id	0.1-mm, 0.2-mm, 0.25-mm, and 0.32-mm capillary columns	5080-8853 (10/pk)
	Ferrule, graphite, 0.4-mm id		500-2114 (10/pk)
	Column nut, finger-tight (for .100- to .320-mm columns)	Connect column to inlet or detector	5020-8292
All	Ferrule, no-hole	Testing	5181-3308 (10/pk)
	Capillary column blanking nut	Testing—use with any ferrule	5020-8294
	Column nut, universal	Connect column to inlet or detector	5181-8830 (2/pk)
	Column cutter, ceramic wafer	Cutting capillary columns	5181-8836 (4/pk)
	Pencil, diamond tipped	Cutting capillary columns	420-1000
	Ferrule tool kit	Ferrule installation	440-1000

**Table 21** Other consumables and parts for the multimode inlet (MMI)

Description/quantity	Part number
Septum retainer nut for headspace	18740-60830
Septum retainer nut	18740-60835
11-mm septum, high-temperature, low-bleed, 50/pk	5183-4757
11-mm septum, prepierced, long life, 50/pk	5183-4761
Merlin Microseal septum (high-pressure)	5182-3444
Merlin Microseal septum (30 psi)	5181-8815
Nonstick fluorocarbon liner O-ring (for temperatures up to 350 °C), 10/pk	5188-5365

**Table 21** Other consumables and parts for the multimode inlet (MMI)

<b>Description/quantity</b>	<b>Part number</b>
Graphite O-ring for split liner (for temperatures above 350 °C), 10/pk	5180-4168
Graphite O-ring for splitless liner (for temperatures above 350 °C), 10/pk	5180-4173
Split vent trap PM kit, single cartridge	5188-6495
Column nut, blanking plug	5020-8294
Cleaning kit, multimode inlet. (Contains 5 each abrasive swabs and 5 each cotton swabs.)	G3510-60820
Column nut adapter	G3510-20018

## Exploded Parts View of the MMI

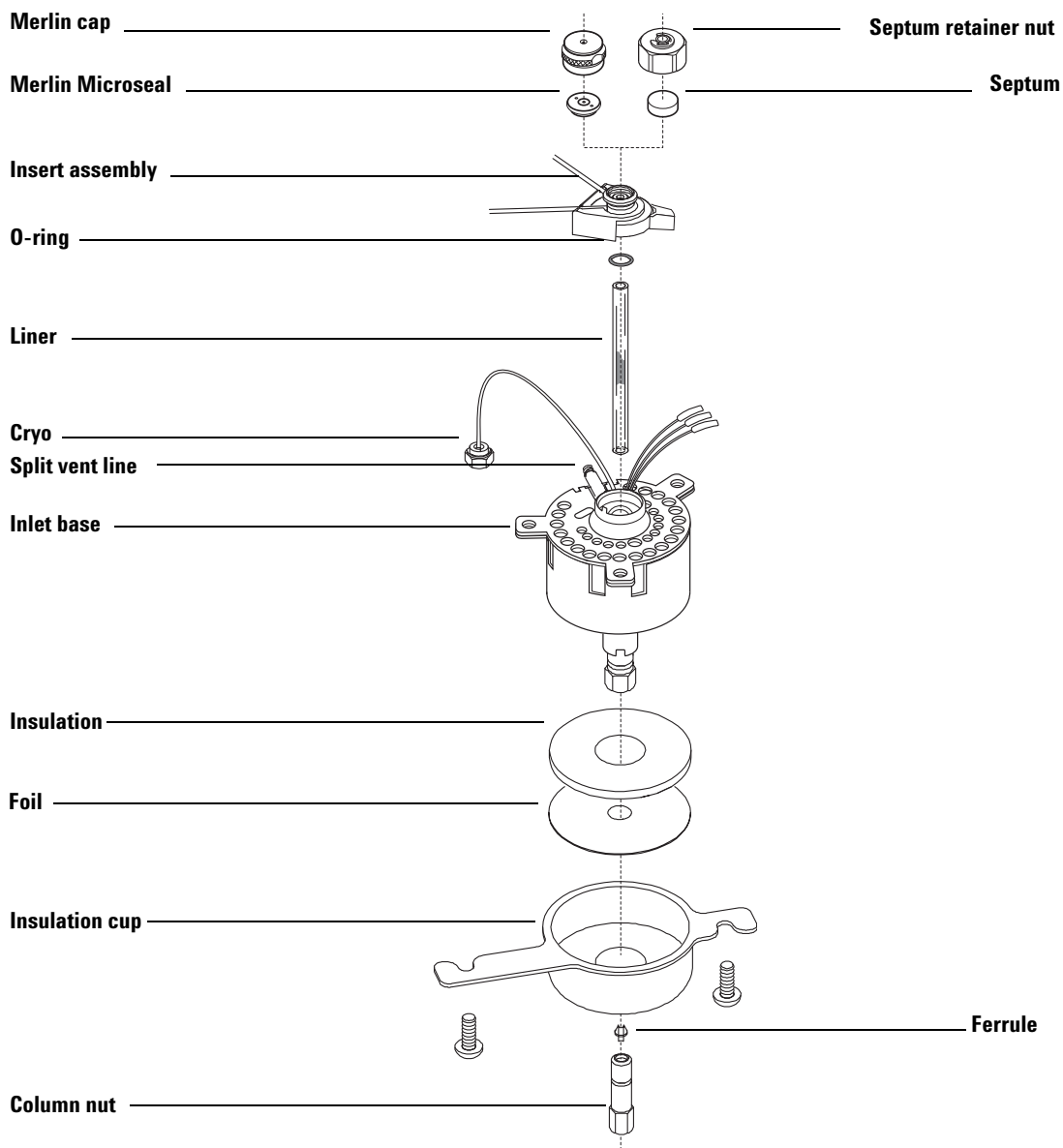

## To Install the Column Nut Adapter

- 1 Gather the following (see “Consumables and Parts for the MMI” on page 128):
  - Column nut adapter
- 2 Load the [GC maintenance method](#) and wait for the GC to become ready.

**WARNING**

**Be careful! The oven and/or inlet may be hot enough to cause burns. If either is hot, wear heat-resistant gloves to protect your hands.**

- 3 When the GC becomes ready, open the GC oven door.
- 4 Thread the column adapter nut onto the base of the inlet.

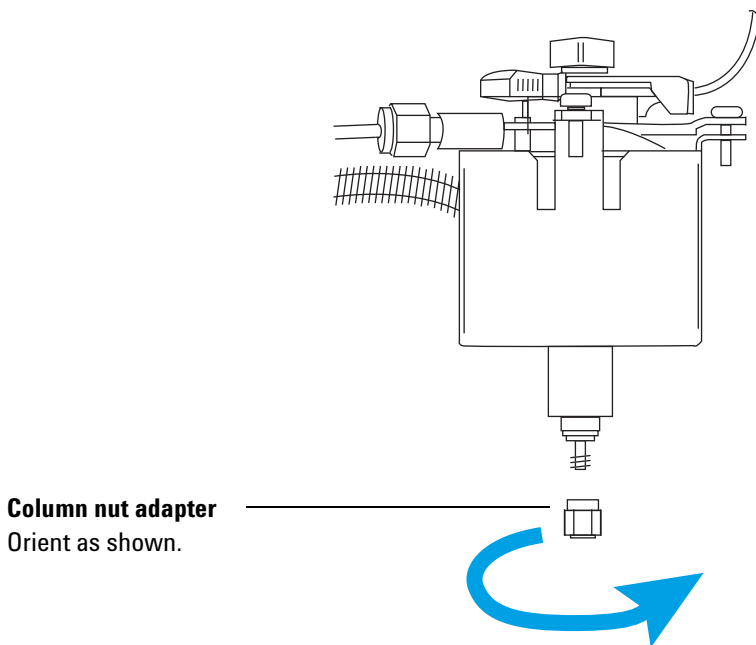

The nut must spin freely before it can be used to install a column.

## To Install a Capillary Column with the MMI

**WARNING**

Do not use hydrogen as the carrier for conditioning! It could vent into the oven and present an explosion hazard.

---

- 1 Gather the following (see “Consumables and Parts for the MMI” on page 128):
  - Column
  - Ferrule(s)
  - Column nut
  - Septum
  - Column cutter
  - Isopropanol
  - Lab tissue
  - Metric ruler
  - 1/4-inch open-end wrenches
  - Lint-free gloves
- 2 Load the [GC maintenance method](#) and wait for the GC to become ready.

**WARNING**

Be careful! The oven and/or inlet may be hot enough to cause burns. If either is hot, wear heat-resistant gloves to protect your hands.

---

**WARNING**

Wear safety glasses to protect your eyes from flying particles while handling, cutting, or installing glass or fused silica capillary columns. Use care in handling these columns to prevent puncture wounds.

---

- 3 Verify that the correct glass liner is installed. (See “Consumables and Parts for the MMI” on page 128.)
- 4 Place the column on the hanger with the ends pointing up and the label to the front.

**CAUTION**

Wear clean, lint-free gloves to prevent contamination of parts with dirt and skin oils.

---

- 5 Place a septum, capillary column nut, and ferrule on the column.

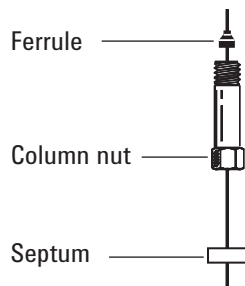

- 6 Score the column using a glass scribing tool. The score must be square to ensure a clean break.

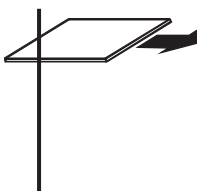

- 7 Break off the column end by supporting it against the column cutter opposite the scribe. Inspect the end with a magnifying loupe to make certain there are no burrs or jagged edges.

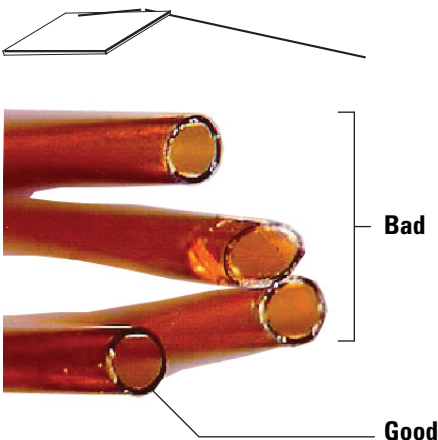

- 8 Wipe the column walls with a tissue dampened with isopropanol to remove fingerprints and dust.
- 9 Position the column so it extends 10 to 12 mm above the end of the ferrule. Slide the septum up the column to hold the column nut at this position.

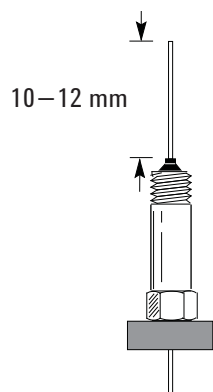

- 10** While holding the inlet base with a wrench thread the column nut into the inlet (but do not tighten).

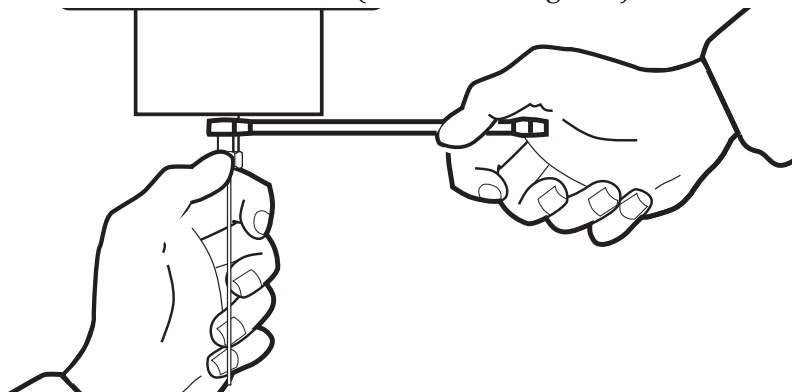

- 11** Adjust the column position so that the septum contacts the bottom of the column nut. Finger-tighten the column nut until it begins to grip the column.
- 12** While holding the inlet base with one wrench, use the second wrench to tighten the column nut an additional 1/4 to 1/2 turn so that the column cannot be pulled from the fitting with gentle pressure.

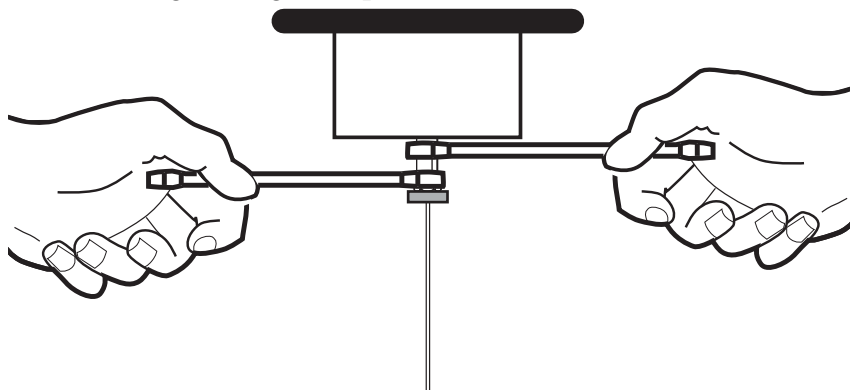

- 13** Configure the new column. If using the optional barcode scanner, scan the column directly into your data system software configuration, then download the changes to the GC.

- 14 Condition the column per the manufacturer's recommendation. (See [To Condition a Capillary Column.](#))
- 15 Install the column into the detector. See:
  - [To Install a Capillary Column in the FID](#)
  - [To Install a Capillary Column in the NPD](#)
  - [To Install a Capillary Column in the TCD](#)
  - [To Install a Capillary Column in the uECD](#)
  - [To install a Capillary Column in the FPD Plus](#)
  - [To Install a Capillary Column Adapter in the FPD](#)
- 16 After the column is installed at both inlet and detector, establish a flow of carrier gas and purge as recommended by the column manufacturer.
- 17 Restore the analytical method.
  - For FID or FPD, immediately turn off the flame.
  - For NPD, immediately turn off the bead.
- 18 After the GC becomes ready, wait 10 minutes then ignite the detector flame or bead.

**WARNING**

**Be careful! The oven, inlet, and/or detector may be hot enough to cause burns. If they are hot, wear heat-resistant gloves to protect your hands.**

---

- 19 Allow the oven, inlet, and detector to equilibrate at operating temperature, then retighten the fittings.
- 20 Reset the column EMF counters. See [To Reset an EMF Counter](#) in the *Operation Manual*.



## To Change the Septum on the MMI

- 1 Gather the following:
  - Replacement septum. (See “Consumables and Parts for the MMI” on page 128.)
  - Wrench, hex for changing septum
  - 0- or 00-grade steel wool (optional)
  - Tweezers
- 2 Load the [inlet maintenance method](#) and wait for the GC to become ready.

### WARNING

**Be careful! The oven and/or inlet may be hot enough to cause burns. If the inlet is hot, wear heat-resistant gloves to protect your hands.**

- 3 Remove the septum retainer nut or Merlin cap.
- 4 Use tweezers to remove the septum or Merlin Microseal from the insert assembly. Do not gouge or scratch the interior of the insert assembly.

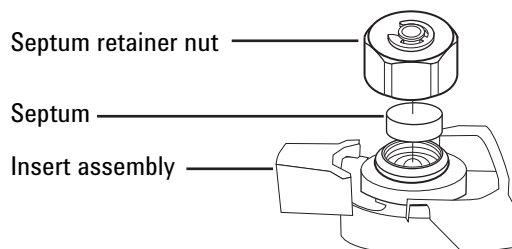

- 5 Firmly press the new septum or Merlin Microseal into the fitting. The metal parts side of the Merlin Microseal should face down (toward the oven).



- 6 Install the septum retainer nut or Merlin cap and finger-tighten. Tighten the septum retainer nut until the C-ring is about 1 mm above the nut.

**CAUTION**

Overtightening the septum nut can cause contamination.

---

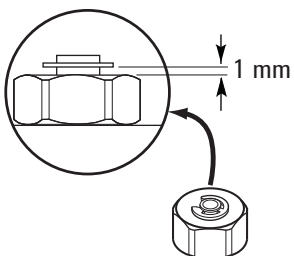

- 7 Restore the analytical method.
- 8 Reset the septum EMF counter. See [To Reset an EMF Counter](#) in the *Operation Manual*.

## To Clean the Septum Seat in the Insert Assembly of the MMI

- 1 Gather the following:
  - Replacement septum (See “Consumables and Parts for the MMI” on page 128.)
  - Wrench, hex for changing septum
  - 0- or 00-grade steel wool (optional)
  - Tweezers
  - Compressed, filtered, dry air or nitrogen
- 2 Load the [inlet maintenance method](#) and wait for the GC to become ready.

**WARNING**

**Be careful! The oven and/or inlet may be hot enough to cause burns. If either is hot, wear heat-resistant gloves to protect your hands.**

---

- 3 Slide the locking tab forward (counterclockwise). Lift the septum assembly straight up and away from the inlet to avoid chipping or breaking the liner.

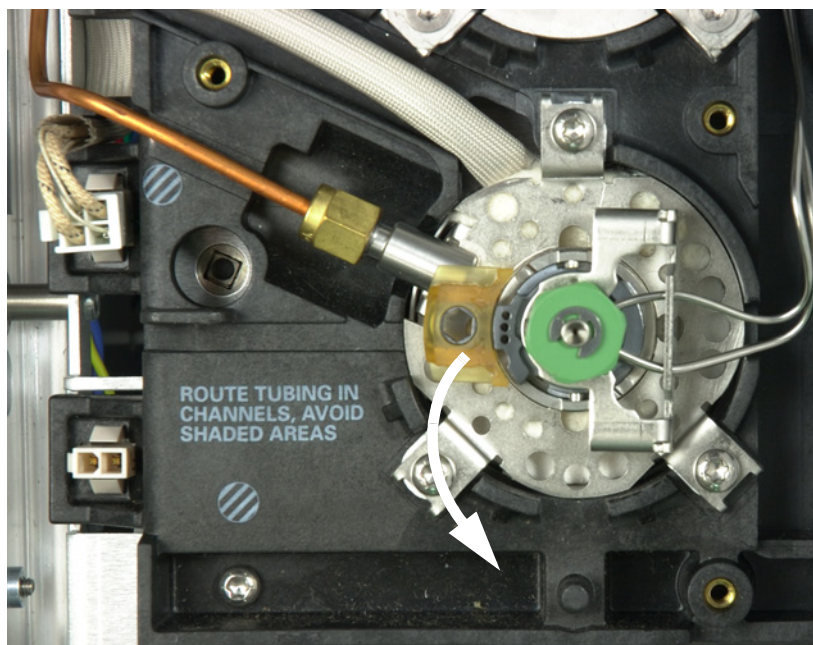

- 4 Remove the septum retainer nut or Merlin cap.

- 5 Use tweezers to remove the septum or Merlin Microseal from the retainer nut. (See [“To Change the Septum on the MMI”](#) on page 137.)
- 6 Scrub the residue from the retainer nut and septum holder with a small piece of rolled-up steel wool and tweezers. Do not do this over the inlet.
- 7 Use compressed air or nitrogen to blow away the pieces of steel wool and septum.
- 8 Line up the tab on the bottom of the septum assembly with the slot on the insert assembly and push down to connect. Slide the locking tab to the left.

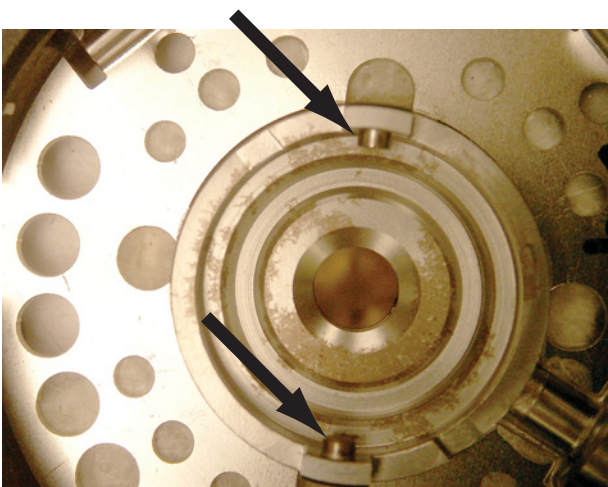

- 9 Firmly press the new septum or Merlin Microseal into the fitting. (See [“To Change the Septum on the MMI”](#) on page 137.)
- 10 Replace the septum retainer nut or Merlin cap and finger-tighten. (See [“To Change the Septum on the MMI”](#) on page 137.)
- 11 Restore the analytical method.
- 12 Reset the septum counter. See [To Reset an EMF Counter](#) in the *Operation Manual*.

## To Change the Liner and O-Ring on the MMI

- 1 Gather the following:
  - Replacement O-ring (See “Consumables and Parts for the MMI” on page 128.)
  - Replacement liner
  - Tweezers
  - Wrench, hex for changing septum
  - Lint-free gloves
- 2 Load the [inlet maintenance method](#) and wait for the GC to become ready.

**WARNING**

**Be careful! The oven and/or inlet may be hot enough to cause burns. If either is hot, wear heat-resistant gloves to protect your hands.**

- 3 Slide the locking tab forward (counterclockwise). Lift the septum assembly straight up and away from the inlet to avoid chipping or breaking the liner.

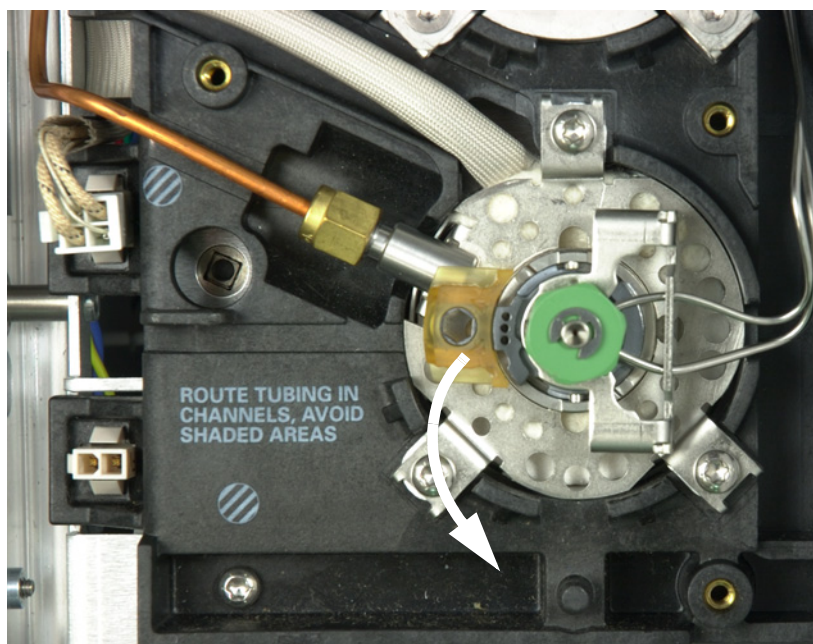

- 4 Loosen the O-ring from the sealing surface with tweezers.

## 8 Maintaining the MMI

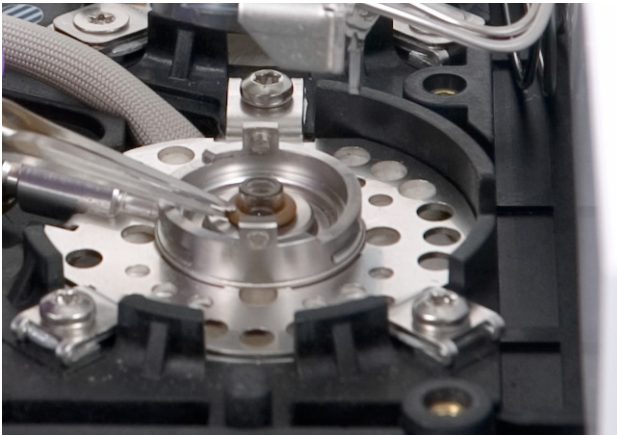

5 Grasp the liner with tweezers and pull it out.



6 Inspect the surface of the seal for contamination. If required, clean with cotton swabs.

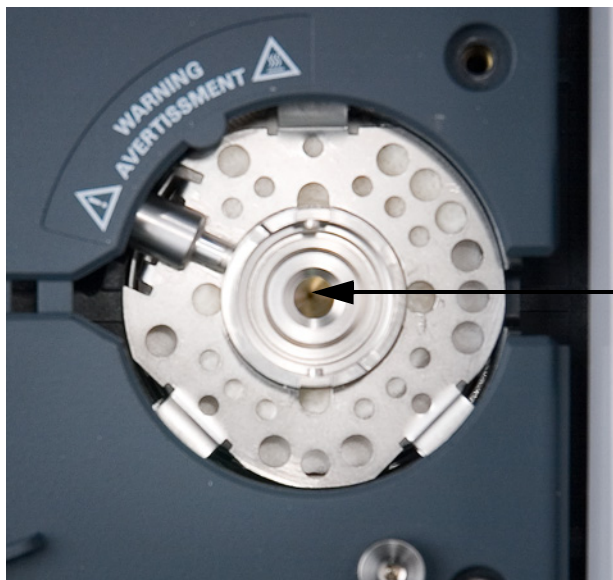

Clean the inlet if there is visible or suspected contamination. (See [“To Clean the Multimode Inlet”](#) on page 147.)

Clean O-ring residue from sealing surface.

**CAUTION**

Wear clean, lint-free gloves to prevent contamination of parts with dirt and skin oils.

- 7 Slide a new O-ring onto the replacement liner.
- 8 Return the liner to the inlet, pushing it all the way in until the liner contacts the seal.



- 9 Line up the tab on the bottom of the septum assembly with the slot on the insert assembly and push down to connect. Slide the locking tab to the back.
- 10 Turn on the inlet. Allow the inlet and column to purge with carrier gas for 15 minutes before heating the inlet or the column oven.
- 11 Bakeout contaminants. (See [“To Bakeout Contaminants from the MMI”](#) on page 149.)
- 12 Restore the analytical method.
- 13 Reset the liner counter. See [To Reset an EMF Counter](#) in the *Operation Manual*.
- 14 If using the optional barcode scanner, scan the liner information directly into your data system software configuration, then download the changes to the GC.
- 15 Check for leaks.

## To Replace the Filter in the Split Vent Line for the MMI

- 1 Gather the following:
  - New filter cartridge. (See “Consumables and Parts for the MMI” on page 128.)
  - T-20 Torx screwdriver
- 2 Load the [inlet maintenance method](#) and wait for the GC to become ready.

**WARNING**

**Be careful! The oven and/or inlet may be hot enough to cause burns. If either is hot, wear heat-resistant gloves to protect your hands.**

**WARNING**

**The split vent trap may contain residual amounts of any samples or other chemicals you have injected into the GC. Follow your company’s safety procedures for handling these types of substances while replacing the trap filter cartridge.**

- 3 Remove the [pneumatics cover](#) (top, back of GC).
- 4 Remove the retaining clip.

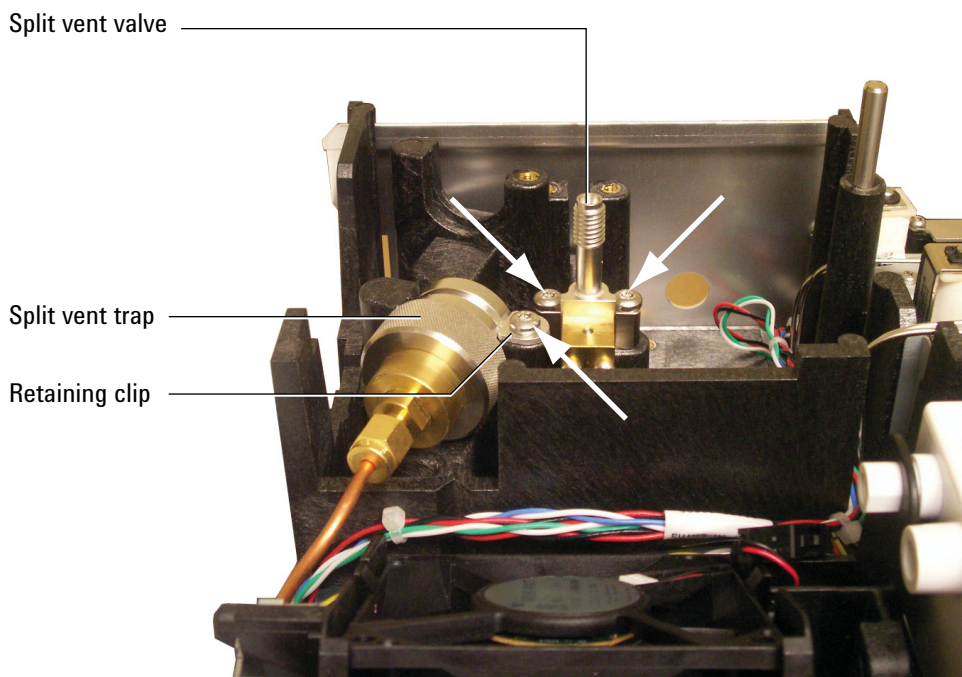



- 5 Completely loosen the two screws that secure the split vent valve in place.
- 6 Lift the filter trap assembly and split vent valve from the mounting bracket together and unscrew the split vent front weldment on the filter trap assembly. Be careful not to stress the tubing between the split vent valve and the trap.

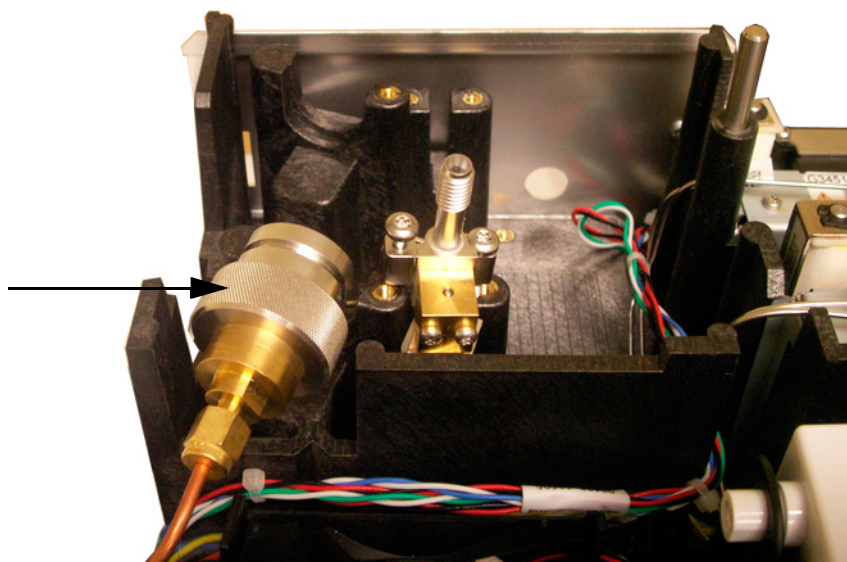

- 7 Remove the old filter cartridge and two O-rings.

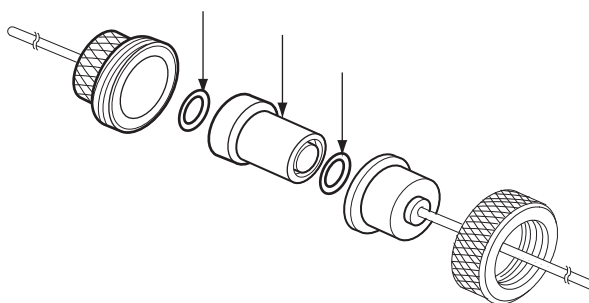

- 8 Verify the new O-rings are seated properly on the new filter cartridge.
- 9 Install the new filter cartridge then reassemble the trap. Do not fully tighten yet.
- 10 Place the filter trap assembly in the mounting bracket and install the retaining clip.
- 11 Install the split vent valve.
- 12 Fully tighten the split vent front weldment onto the trap.
- 13 Check for leaks.

## **8** Maintaining the MMI

- 14** Reset the EMF counter. See [To reset an EMF counter](#).
- 15** Restore the analytical method.
- 16** Reset the split vent trap counter.
- 17** Install the pneumatics cover.

## To Clean the Multimode Inlet

This procedure explains how to clean the Multi Mode Inlet (MMI). Depending on the inlet mode used, the liner installed, and the cleanliness of the sample, the frequency of cleaning may range from weekly to monthly. Start with a visual inspection of the inlet bottom whenever changing the liner. A small ring of material will collect at the bottom of the inlet when injecting dirty samples such as food extracts or solid waste. Try an initial cleaning schedule of every two weeks for dirty samples and every two months for clean samples and adjust as needed.

- 1 Gather the following:
  - Cleaning kit, multimode inlet (G3510-60820). Contains 5 each abrasive swabs and 5 each cotton swabs.
  - Solvent for cleaning (at least 25 mL of acetone, isopropanol, or hexane, whichever is most appropriate for your sample matrix).
  - 100 mL beaker or similar container to the catch solvent rinse.
- 2 Load the [inlet maintenance method](#) and wait for the GC to become ready.

**WARNING**

**Be careful! The oven and/or inlet may be hot enough to cause burns. If the inlet is hot, wear heat-resistant gloves to protect your hands.**

---

- 3 Turn off the GC.

**CAUTION**

Wear clean, lint-free gloves to prevent contamination of parts with dirt and skin oils.

---

- 4 Remove the inlet liner. (See [“To Change the Liner and O-Ring on the MMI”](#) on page 141.)
- 5 Remove the column from the inlet. (See [“To Install a Capillary Column with the MMI”](#) on page 133.)
- 6 Place the glass beaker or other container in the GC oven, below the MMI inlet, so it will catch any solvent that drips through the inlet body.

- 7** Moisten a cotton swab with solvent and wipe the inside bottom seal of the inlet repeatedly to remove any loose material from the MMI. If desired, the cotton swab can be used to clean the bore of the inlet. For most samples, this is not necessary. Dispose of the swab after a single use.
- 8** Using a dry abrasive swab, place the swab all the way to the bottom of the inlet and with moderate pressure, twist the swab forwards and backwards while it is in contact with the bottom of the MMI (approximately 20 cycles should be sufficient). The abrasive swab can be used multiple times.
- 9** Using a second solvent moistened cotton swab, wipe the bottom of the inlet to remove any residue. Depending on the amount of use and maximum temperature used, the bottom of the inlet may still show some oxidation (light brown color). This is normal and will not affect inlet performance. Repeat steps 3-5 (if necessary) to remove any remaining deposits.
- 10** Using clean solvent, rinse the inlet volume several times but never overfill the inlet bore. Position a container under the column opening in the inlet to catch the used solvent exiting the bottom of the MMI.
- 11** Allow the inlet to dry.
- 12** Install the liner and O-ring.
- 13** Reinstall the column.
- 14** Turn on the GC.
- 15** Check for leaks.
- 16** Restore the analytical method.

## To Bakeout Contaminants from the MMI

- 1 Put the inlet into split mode.
- 2 Set the column flow to the normal operating value, or set the capillary column gas velocity to 30 cm/s.
- 3 Set the inlet split vent flow to 200 mL/min.
- 4 Purge the column with carrier flow for at least 10 minutes before heating the oven.
- 5 If the column is attached to the detector, set the detector 25 °C above normal operating temperature.

**WARNING**

**Be careful! The oven, inlet, and/or detector may be hot enough to cause burns. If they are hot, wear heat-resistant gloves to protect your hands.**

---

If the column is not attached to the detector, cap the detector fitting.

- 6 Set the inlet temperature to 300 °C or 25 °C above the normal operating temperature to bakeout contaminants from the inlet, mostly through the split vent.
- 7 Set the column oven 25 °C above the GC method final oven temperature to bake contaminants from the column. Do not exceed the column manufacturer's maximum temperature limit.
- 8 Bakeout for 30 minutes or until the detector baseline is free of contamination peaks.

## **8 Maintaining the MMI**



## 9 Maintaining the PTV Inlet

- Consumables and Parts for the PTV Inlet [152](#)
- Exploded Parts View of the PTV Inlet [154](#)
- To Install a Capillary Column with the PTV Inlet [155](#)
- To Clean the Septumless Head on the PTV Inlet [158](#)
- To Replace the Septumless Head PTFE Ferrule on the PTV Inlet [161](#)
- To Change the Septum on the PTV Inlet [163](#)
- To Clean the Septum Seat in the Septum Head Assembly of the PTV Inlet [165](#)
- To Change the Liner on the PTV Inlet [167](#)
- To Replace the Inlet Adapter for the PTV Inlet [170](#)
- To Replace the Filter in the Split Vent Line for the PTV Inlet [172](#)
- To Bakeout Contaminants from the PTV Inlet [175](#)



## Consumables and Parts for the PTV Inlet

See the Agilent catalog for consumables and supplies for a more complete listing, or visit the Agilent Web site for the latest information ([www.agilent.com/chem/supplies](http://www.agilent.com/chem/supplies)).

**Table 22** PTV liners and ferrules

Description	Part number
Single baffle, 2-mm id, 180- $\mu$ L, deactivated, glass wool	5183-2038
Single baffle, 2-mm id, 200- $\mu$ L, deactivated	5183-2036
Multi-baffle, 1.5-mm id, 150- $\mu$ L, deactivated	5183-2037
Fritted glass, 1.5-mm id, 150- $\mu$ L, deactivated	5183-2041
Graphpak 3D ferrules for liner	5182-9749 (5/pk)
Installation tool for 3D ferrules	G2617-80540

**Table 23** Other consumables and parts for the PTV inlet

Description	Part number
Syringe, 5- $\mu$ L, 23-gauge fixed-needle	9301-0892
Syringe, 10- $\mu$ L, 23-gauge fixed-needle	9301-0713
Syringe, 50- $\mu$ L, 23-gauge fixed-needle, for large volume injections	5183-0318
Syringe, 100- $\mu$ L, 23-gauge fixed-needle, for large volume injections	5183-2058
Split vent trap PM kit, single cartridge	5188-6495
<b>Septumless head</b>	
Septumless head	G2617-60507
PTFE ferrules (needle seal)	5182-9748 (10/pk)
Septumless head rebuild kit (includes Viton seal, Kalrez seal, and pressure spring)	5182-9747
Carrier gas tube for septumless head	G2617-80550
Ferrule, 1/16-inch PTFE, for septumless head carrier gas tube	0100-1375
<b>Septum head</b>	
Merlin Microseal septum (high-pressure)	5182-3444
11-mm septa, red	5181-1263 (50/pk)

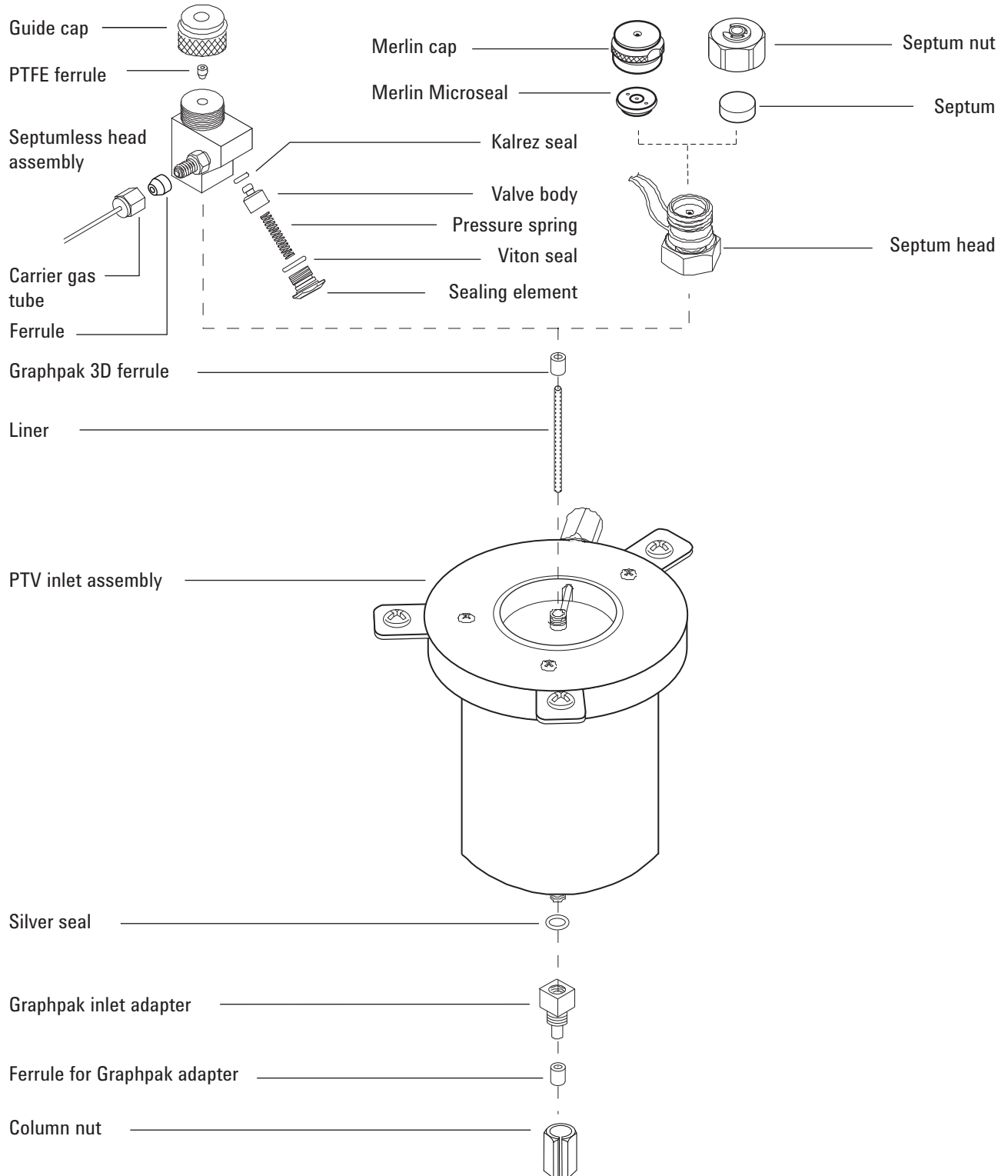

**Table 23** Other consumables and parts for the PTV inlet (continued)

<b>Description</b>	<b>Part number</b>
<b>Column adapter parts</b>	
Silver seal	5182-9763 (5/pk)
Graphpak 2M inlet adapter, 0.20-mm id*	5182-9754
Graphpak 2M inlet adapter, 0.25- to 0.33-mm id*	5182-9761
Graphpak 2M inlet adapter, 0.53-mm id*	5182-9762
Ferrules for Graphpak 2M inlet, 0.20-mm id	5182-9756 (10/pk)
Ferrules for Graphpak 2M inlet, 0.25-mm id	5182-9768 (10/pk)
Ferrules for Graphpak 2M inlet, 0.32-mm id	5182-9769 (10/pk)
Ferrules for Graphpak 2M inlet, 0.53-mm id	5182-9770 (10/pk)
Split nut for Graphpak adapter	5062-3525

\* Includes (1) adapter, (1) silver seal, and (1) split column nut.

## Exploded Parts View of the PTV Inlet



## To Install a Capillary Column with the PTV Inlet

- 1 Gather the following (see [“Consumables and Parts for the PTV Inlet”](#) on page 152):
  - Column
  - Graphpak 2M ferrule
  - Column nut
  - Column cutter
  - Septum
  - Isopropanol
  - Lab tissue
  - Metric ruler
  - 5-mm and 6-mm wrenches
  - Typewriter correction fluid or a marker
  - Lint-free gloves
- 2 Load the [GC maintenance method](#) and wait for the GC to become ready.

**WARNING**

**Be careful! The oven and/or inlet may be hot enough to cause burns. If either is hot, wear heat-resistant gloves to protect your hands.**

---

**WARNING**

**Wear safety glasses to protect your eyes from flying particles while handling, cutting, or installing glass or fused silica capillary columns. Use care in handling these columns to prevent puncture wounds.**

---

- 3 Before installing the column, install the correct column adapter. (See [“To Replace the Inlet Adapter for the PTV Inlet”](#) on page 170.)

**CAUTION**

Wear clean, lint-free gloves to prevent contamination of parts with dirt and skin oils.

---

- 4 Place the column on the hanger with the ends pointing up and the label to the front.
- 5 Place a Graphpak 2M ferrule onto the column, with the graphite facing up towards the inlet.

- 6 Score the column using a glass scribing tool. The score must be square to ensure a clean break.

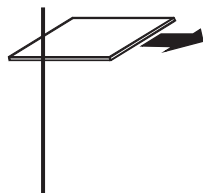

- 7 Break off the column end by supporting it against the column cutter opposite the scribe. Inspect the end with a magnifying loupe to make certain that there are no burrs or jagged edges.

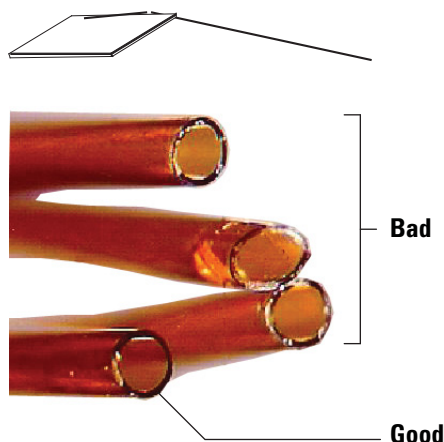

- 8 Wipe the column walls with a tissue dampened with isopropanol to remove fingerprints and dust.
- 9 Position the column so it extends 17 mm above the end of the ferrule. Mark the column behind the ferrule with typewriter correction fluid or a marker. Slide the nut over the column.



- 10 Insert the column into the adapter and finger-tighten the column nut. Looking through the slot in the nut, adjust

the column until the mark is correctly positioned below the Graphpak 2M ferrule.

- 11 Tighten the column nut an additional 1/8 to 1/4 turn with a wrench. Do not overtighten.
- 12 Configure the new column. If using the optional barcode scanner, scan the column directly into your data system software configuration, then download the changes to the GC.
- 13 Condition the column per the manufacturer's recommendation. (See [To Condition a Capillary Column.](#))
- 14 Install the column into the detector. See:
  - [To Install a Capillary Column in the FID](#)
  - [To Install a Capillary Column in the NPD](#)
  - [To Install a Capillary Column in the TCD](#)
  - [To Install a Capillary Column in the uECD](#)
  - [To install a Capillary Column in the FPD Plus](#)
  - [To Install a Capillary Column Adapter in the FPD](#)
- 15 After the column is installed at both inlet and detector, establish a flow of carrier gas and purge as recommended by the column manufacturer.
- 16 Restore the analytical method.
  - For FPD, immediately turn off the flame.
  - For NPD, immediately set the bead voltage to 0.0.
- 17 After the GC becomes ready, wait 10 minutes then ignite the detector flame or adjust offset on the NPD bead.

**WARNING**

**Be careful! The oven, inlet, and/or detector may be hot enough to cause burns. If they are hot, wear heat-resistant gloves to protect your hands.**

---

- 18 Allow the oven, inlet, and detector to equilibrate at operating temperature, then retighten the fittings.
- 19 Reset the column EMF counters. See [To Reset an EMF Counter](#) in the *Operation Manual*.

## To Clean the Septumless Head on the PTV Inlet

- 1 Gather the following:
  - Syringe with 23-gauge needle (See “Consumables and Parts for the PTV Inlet” on page 152.)
  - Septumless head rebuild kit
  - Hexane
  - Clean, lint-free gloves
  - 5/16-inch wrench
  - Lint-free gloves
- 2 Load the [inlet maintenance method](#) and wait for the GC to become ready.
- 3 Disconnect the carrier gas line.

**WARNING**

**Be careful! The oven and/or inlet may be hot enough to cause burns. If either is hot, wear heat-resistant gloves to protect your hands.**

---

- 4 Unscrew and remove the septumless head assembly from the inlet.

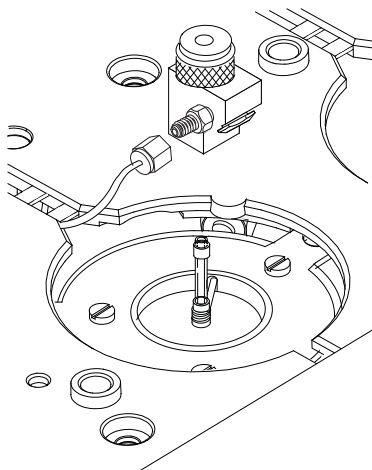

- 5 Unscrew the sealing element from the head assembly and carefully remove the Viton seal and the pressure spring

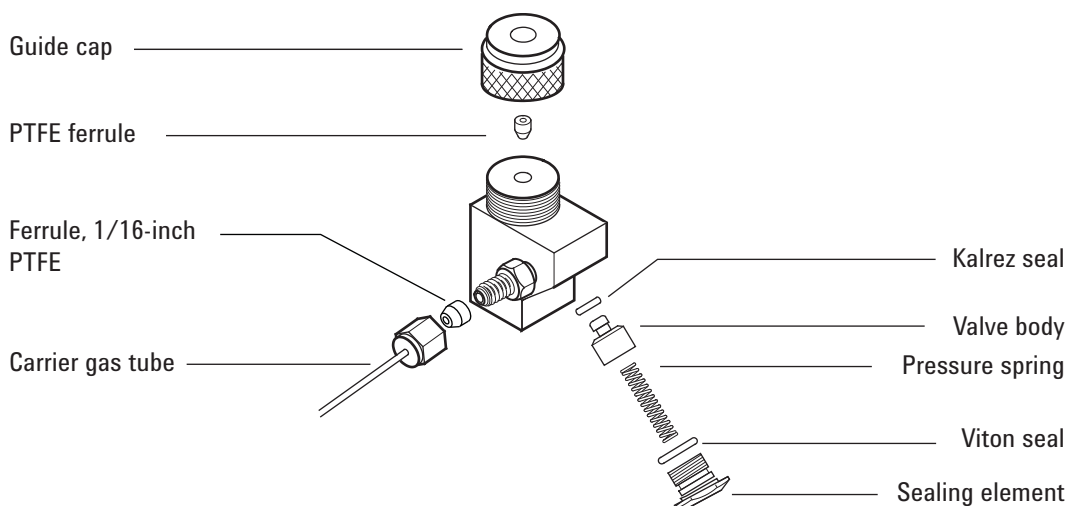

- 6 Unscrew the guide cap from the head and remove the PTFE ferrule.
- 7 Carefully insert a syringe with a 23-gauge needle into the head to press the valve body and Kalrez seal slightly out of the head.
- 8 Gently tap the head on a soft, smooth surface so that the valve body falls out completely or slips out far enough to grasp with fingers.
- 9 Remove the Kalrez seal from the valve body.
- 10 Clean all components in hexane.

**CAUTION**

Wear clean, lint-free gloves to prevent contamination of parts with dirt and skin oils.

- 11 Replace the PTFE ferrule. (See [“To Replace the Septumless Head PTFE Ferrule on the PTV Inlet”](#) on page 161.)
- 12 Wearing clean lint-free gloves, reassemble the head in reverse order. Be sure that the seals and the pressure spring are not damaged.
- 13 Finger-tighten the septumless head, then tighten an additional 1/8 turn with a wrench.
- 14 Reconnect the carrier gas line.
- 15 Check for leaks; if necessary, slightly tighten the guide cap with the syringe needle inserted.
  - If the head leaks with the syringe inserted, replace the PTFE ferrule.

## 9 Maintaining the PTV Inlet

- If the head leaks without the syringe inserted, replace the Kalrez and Viton seals.

**16** Restore the analytical method.



## To Replace the Septumless Head PTFE Ferrule on the PTV Inlet

- 1 Gather the following:
  - Syringe with 23-gauge needle (See “Consumables and Parts for the PTV Inlet” on page 152.)
  - Replacement PTFE ferrule
- 2 Load the [inlet maintenance method](#) and wait for the GC to become ready.

### WARNING

**Be careful! The oven and/or inlet may be hot enough to cause burns. If either is hot, wear heat-resistant gloves to protect your hands.**

- 3 Unscrew the guide cap from the septumless head and remove the PTFE ferrule.
- 4 Push the guide cap and replacement ferrule over the syringe needle so that at least 10 mm of the needle tip is exposed.

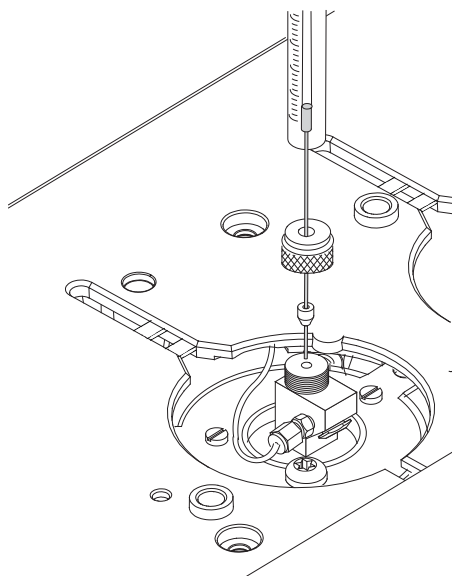

- 5 Guide the end of the needle into the septumless head until the ferrule meets the septumless head.
- 6 Loosely install the guide cap.
- 7 If not configured, configure the column.
- 8 Put the inlet into **Splitless** mode.
- 9 Set the column flow to 5 mL/min and the purge flow to 60 mL/min.

- 10 After the inlet pressurizes, press [**Prep Run**] twice.
- 11 Observe the inlet **Total Flow**. Tighten the guide cap until the **Total Flow** stops decreasing (typically near 8 mL/min).
- 12 Remove the syringe from the inlet and press [**Stop**].
- 13 Restore the analytical method.
- 14 Reset the EMF counter. See [To Reset an EMF Counter](#) in the *Operation Manual*.

## To Change the Septum on the PTV Inlet

- 1 Gather the following:
  - Replacement septum. (See “Consumables and Parts for the PTV Inlet” on page 152.)
  - 5/8-inch wrench
- 2 Load the [inlet maintenance method](#) and wait for the GC to become ready.

### WARNING

**Be careful! The oven and/or inlet may be hot enough to cause burns. If either is hot, wear heat-resistant gloves to protect your hands.**

- 3 Remove the septum retainer nut or Merlin cap. If the septum head begins to turn during removal, support it manually while removing the cap.
- 4 Use tweezers to remove the septum or Merlin Microseal from the retainer nut. Do not gouge or scratch the interior of the septum head.
- 5 Firmly press the new septum or Merlin Microseal into the fitting. The metal parts side of the Merlin Microseal should face down (toward the oven).

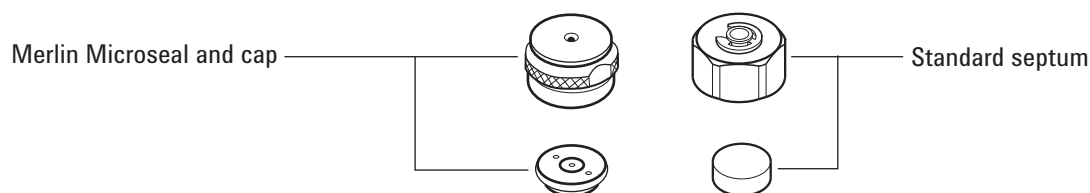

- 6 Replace the septum retainer nut or Merlin cap and finger-tighten. Tighten the septum retainer nut until the C-ring is about 1 mm above the nut.

### CAUTION

Overtightening the septum nut can cause contamination.

## 9 Maintaining the PTV Inlet

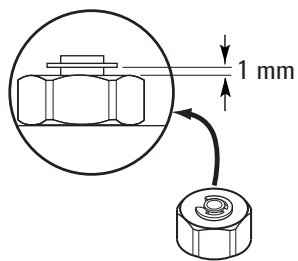

- 7 Restore the analytical method.
- 8 Reset the septum counter. See [To Reset an EMF Counter](#) in the *Operation Manual*.

## To Clean the Septum Seat in the Septum Head Assembly of the PTV Inlet

- 1 Gather the following:
  - Replacement septum (See “Consumables and Parts for the PTV Inlet” on page 152.)
  - 5/8-inch wrench
  - Tweezers
  - Compressed, filtered, dry air or nitrogen
  - Lint-free gloves
- 2 Load the [inlet maintenance method](#) and wait for the GC to become ready.

**WARNING**

**Be careful! The oven and/or inlet may be hot enough to cause burns. If either is hot, wear heat-resistant gloves to protect your hands.**

---

**CAUTION**

Wear clean, lint-free gloves to prevent contamination of parts with dirt and skin oils.

---

- 3 Remove the septum retainer nut or Merlin cap. If the septum head begins to turn during removal, support it manually while removing the cap.
- 4 Unscrew the septum head assembly from the inlet and move it up and away from the inlet.
- 5 Use tweezers to remove the septum or Merlin Microseal from the retainer nut. Do not gouge or scratch the interior of the septum head.
- 6 Scrub the residue from the retainer nut and septum holder with a small piece of rolled-up steel wool and tweezers. Do not do this over the inlet.
- 7 Use compressed air or nitrogen to blow away the pieces of steel wool and septum.
- 8 Replace the septum head assembly on the inlet. Finger-tighten the septum head and then tighten an additional 1/2 turn with a wrench.
- 9 Firmly press the new septum or Merlin Microseal into the fitting. (See “To Change the Septum on the PTV Inlet” on page 163.)

- 10** Replace the septum retainer nut or Merlin cap and finger-tighten. (See [“To Change the Septum on the PTV Inlet”](#) on page 163.)
- 11** Restore the analytical method.
- 12** Reset the septum counter. See [To Reset an EMF Counter](#) in the *Operation Manual*.

## To Change the Liner on the PTV Inlet

- 1 Gather the following:
  - Installation tool for 3D ferrules (See “Consumables and Parts for the PTV Inlet” on page 152.)
  - Assembly tool (part number G2617-80540)
  - Replacement liner
  - Graphpak 3D ferrule
  - 5/16-inch wrench
  - Lint-free gloves
- 2 Load the [inlet maintenance method](#) and wait for the GC to become ready.

**WARNING**

**Be careful! The oven and/or inlet may be hot enough to cause burns. If either is hot, wear heat-resistant gloves to protect your hands.**

---

**CAUTION**

Wear clean, lint-free gloves to prevent contamination of parts with dirt and skin oils.

---

- 3 Remove the head from the inlet:
  - For septumless head, disconnect the carrier gas line and unscrew and remove the septumless head assembly from the inlet.
  - For septum head, loosen the septum head assembly from the inlet. Lift the head to clear the inlet and push to either side. Do not bend the 1/16-inch lines too much.
- 4 Grasp the liner by the Graphpak 3D ferrule. Remove the liner from the inlet.

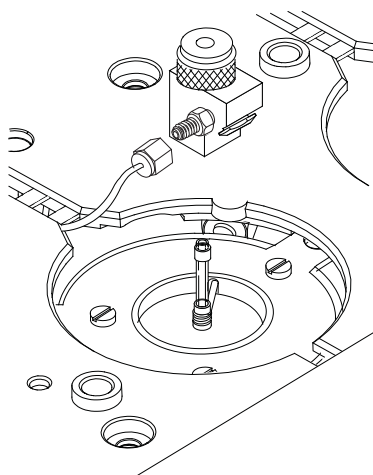

- 5 Unscrew the assembly tool into two pieces: the ferrule guide and the compression fitting.

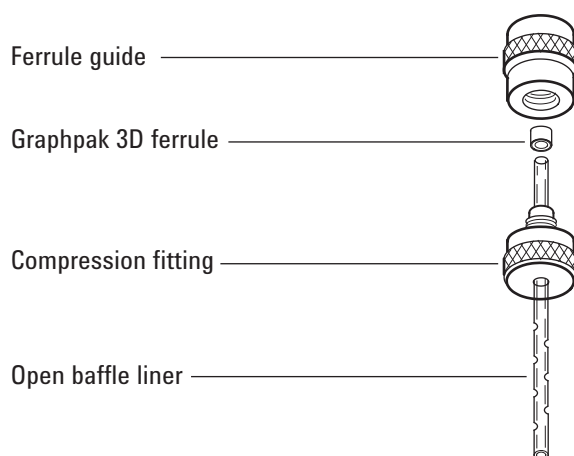

- 6 Slide the compression fitting onto the longer, straight end of the new liner with the threads pointing toward the end of the liner.
- 7 Place a Graphpak 3D ferrule on the same end of the liner with the recessed graphite end towards the compression fitting. Slide the ferrule so that about 2 mm of the liner is exposed beyond the ferrule.
- 8 Slide the compression fitting up to meet the ferrule. Finger-tighten the ferrule guide onto the compression fitting.
- 9 Unscrew and remove the ferrule guide.
- 10 Slide the compression fitting off the other end of the liner. The ferrule should now be set with 1 mm of the liner exposed. Check that the graphite within the ferrule is flush with the top of the metal collar.



- 11 Insert the glass liner into the inlet from above until the unpacked side of the ferrule rests on the top of the inlet.
- 12 Replace the head:
  - For septumless head, screw the head onto the inlet and tighten 1/8 turn past finger-tight with a wrench. Reconnect the carrier gas line.
  - For septum head, align the head with the inlet and manually engage the free-spinning nut to the inlet. Tighten 1/2 turn past finger-tight with a wrench.
- 13 Check all connections for leaks. If necessary, tighten them again by hand.
- 14 Restore the analytical method.
- 15 Configure the new liner. If using the optional barcode scanner, scan the liner directly into your data system software configuration, then download the changes to the GC.
- 16 Reset the liner counters. See [To Reset an EMF Counter](#) in the *Operation Manual*.

## To Replace the Inlet Adapter for the PTV Inlet

- 1 Select from the following list an adapter with the smallest hole diameter that will accept the column. The adapter number is stamped on the side of the adapter. (Also see [“Consumables and Parts for the PTV Inlet”](#) on page 152.)

**Table 24** PTV inlet adapters

Column id	Inlet adapter number*	Part number
0.20 mm	31	5182-9754
0.25 to 0.33 mm	45	5182-9761
0.53 mm	70	5182-9762

\* Includes (1) adapter, (1) silver seal, and (1) split column nut.

- 2 Gather the following:
  - Replacement adapter
  - Replacement silver seal
  - 6-mm wrench
  - 5-mm wrench
  - Lint-free gloves
- 3 Load the [inlet maintenance method](#) and wait for the GC to become ready.

### WARNING

**Be careful! The oven and/or inlet may be hot enough to cause burns. If either is hot, wear heat-resistant gloves to protect your hands.**

### CAUTION

Wear clean, lint-free gloves to prevent contamination of parts with dirt and skin oils.

- 4 Unscrew the column nut from the adapter. Remove the nut and the column from the inlet.

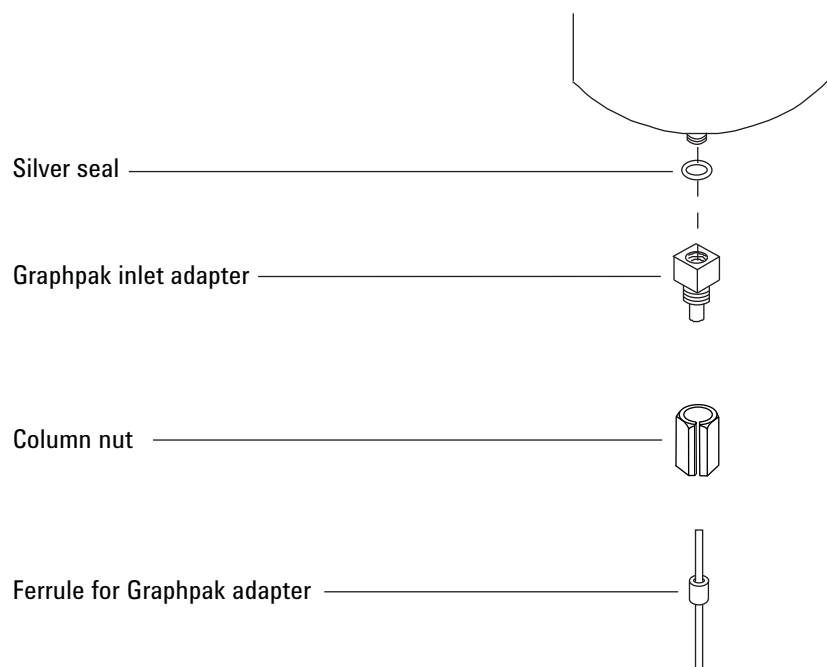

- 5 Remove the inlet adapter and discard the old silver seal.
- 6 Insert a new silver seal into the adapter and finger-tighten the adapter onto the inlet. Tighten an additional  $1/16$  to  $1/8$  turn with a wrench; overtightening will damage the inlet.
- 7 Install the column. (See [“To Install a Capillary Column with the PTV Inlet”](#) on page 155.)
- 8 Check the adapter for leaks.
- 9 Restore the analytical method.
- 10 Reset the silver seal EMF counter. See [To Reset an EMF Counter](#) in the *Operation Manual*.

## To Replace the Filter in the Split Vent Line for the PTV Inlet

- 1 Gather the following:
  - New filter cartridge. (See “Consumables and Parts for the PTV Inlet” on page 152.)
  - T-20 Torx screwdriver
- 2 Load the [inlet maintenance method](#) and wait for the GC to become ready.

**WARNING**

**Be careful! The oven and/or inlet may be hot enough to cause burns. If either is hot, wear heat-resistant gloves to protect your hands.**

---

**WARNING**

**The split vent trap may contain residual amounts of any samples or other chemicals you have injected into the GC. Follow your company’s safety procedures for handling these types of substances while replacing the trap filter cartridge.**

---

- 3 Remove the [pneumatics cover](#) (top, back of GC).
- 4 Remove the retaining clip.

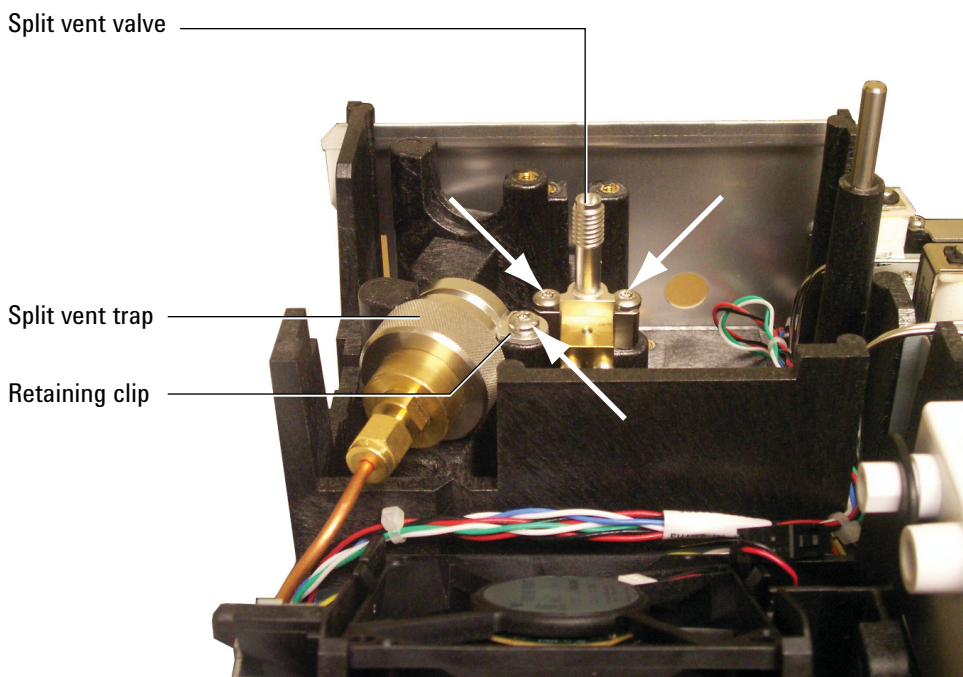

- 5 Completely loosen the two screws that secure the split vent valve in place.
- 6 Lift the filter trap assembly and split vent valve from the mounting bracket together and unscrew the split vent front weldment on the filter trap assembly. Be careful not to stress the tubing between the split vent valve and the trap.

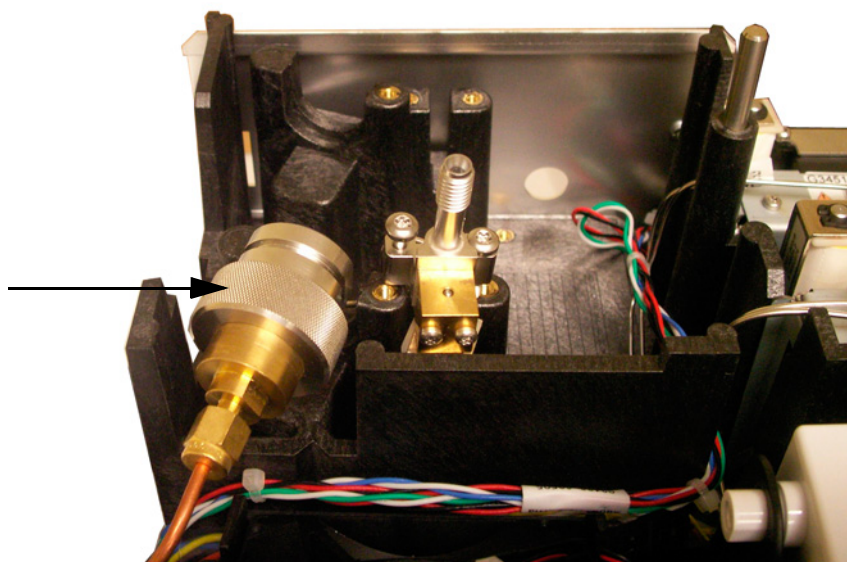

- 7 Remove the old filter cartridge and two O-rings.

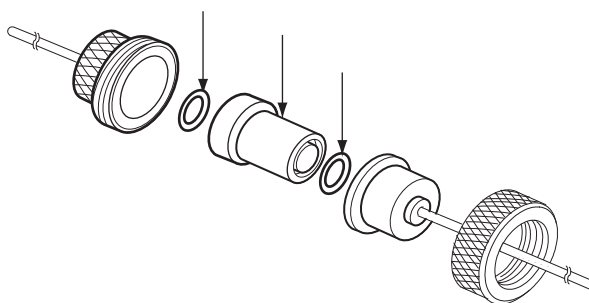

- 8 Verify the new O-rings are seated properly on the new filter cartridge.
- 9 Install the new filter cartridge then reassemble the trap. Do not fully tighten yet.
- 10 Place the filter trap assembly in the mounting bracket and install the retaining clip.
- 11 Install the split vent valve.
- 12 Fully tighten the split vent front weldment onto the trap.
- 13 Check for leaks.

## **9** Maintaining the PTV Inlet

- 14** Reset the EMF counter. See [To reset an EMF counter](#).
- 15** Restore the analytical method.
- 16** Reset the split vent trap counter.
- 17** Install the pneumatics cover.

## To Bakeout Contaminants from the PTV Inlet

- 1 Put the inlet into split mode.
- 2 Set the column flow to the normal operating value, or set the capillary column gas velocity to 30 cm/s.
- 3 Set the inlet split vent flow to 200 mL/min.
- 4 Purge the column with carrier flow for at least 10 minutes before heating the oven.
- 5 If the column is attached to the detector, set the detector 25 °C above normal operating temperature.

**WARNING**

**Be careful! The oven, inlet, and/or detector may be hot enough to cause burns. If they are hot, wear heat-resistant gloves to protect your hands.**

---

If the column is not attached to the detector, cap the detector fitting.

- 6 Set the inlet temperature to 300 °C or 25 °C above the normal operating temperature to bakeout contaminants from the inlet, mostly through the split vent.
- 7 Set the column oven 25 °C above the GC method final oven temperature to bake contaminants from the column. Do not exceed the column manufacturer's maximum temperature limit.
- 8 Bakeout for 30 minutes or until the detector baseline is free of contamination peaks.

## **9 Maintaining the PTV Inlet**



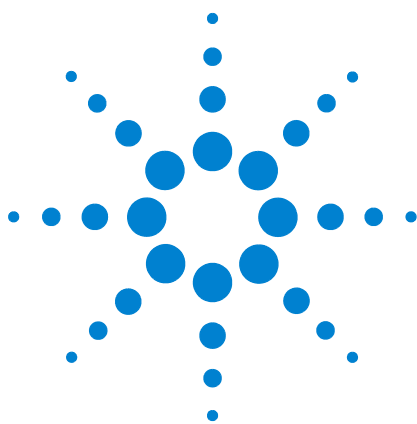

## 10 Maintaining the VI

- Consumables and Parts for the VI [178](#)
- Exploded Parts View of the VI [180](#)
- To Install a Capillary Column with the VI [181](#)
- To Remove the VI Interface [185](#)
- To Clean the VI [187](#)
- To Install the VI Interface [189](#)
- To Replace the Filter in the Split Vent Line for the VI [190](#)
- To Bakeout Contaminants from the VI Inlet [193](#)



## Consumables and Parts for the VI

See the Agilent catalog for consumables and supplies for a more complete listing, or visit the Agilent Web site for the latest information ([www.agilent.com/chem/supplies](http://www.agilent.com/chem/supplies)).

**Table 25** Parts for the VI

Description	Part number
Clamping plate	G2319-20540
Volatiles interface	G2319-60505
Long column nut (65 mm)	G3504-20504
Nut, for transfer, pressure sensing, or split vent line	19258-20830
Ferrule, for transfer, pressure sensing, or split vent line	19258-20870
Split vent trap PM kit, single cartridge	5188-6495

**Table 26** Nuts, ferrules, and hardware for capillary columns

Column id (mm)	Description	Typical use	Part number/quantity
.530	Ferrule, Vespel/graphite, 0.8-mm id	0.45-mm and 0.53-mm capillary columns	5062-3512 (10/pk)
	Ferrule, graphite, 1.0-mm id	0.53-mm capillary columns	5080-8773 (10/pk)
	Ferrule, graphite, 0.8-mm id	0.53-mm capillary columns	500-2118 (10/pk)
	Column nut, finger-tight (for 0.53-mm columns)	Connect column to inlet or detector	5020-8293
.320	Ferrule, Vespel/graphite, 0.5-mm id	0.32-mm capillary columns	5062-3514 (10/pk)
	Ferrule, graphite, 0.5-mm id	0.1-mm, 0.2-mm, 0.25-mm, and 0.32-mm capillary columns	5080-8853 (10/pk)
	Column nut, finger-tight (for .100- to .320-mm columns)	Connect column to inlet or detector	5020-8292
.250	Ferrule, Vespel/graphite, 0.4-mm id	0.1-mm, 0.2-mm, and 0.25-mm capillary columns	5181-3323 (10/pk)
	Ferrule, graphite, 0.5-mm id	0.1-mm, 0.2-mm, 0.25-mm, and 0.32-mm capillary columns	5080-8853 (10/pk)
	Column nut, finger-tight (for .100- to .320-mm columns)	Connect column to inlet or detector	5020-8292

**Table 26** Nuts, ferrules, and hardware for capillary columns (continued)

Column id (mm)	Description	Typical use	Part number/quantity
.100 and .200	Ferrule, Vespel/graphite, 0.37-mm id	0.1-mm and 0.2-mm capillary columns	5062-3516 (10/pk)
	Ferrule, Vespel/graphite, 0.4-mm id	0.1-mm, 0.2-mm, and 0.25-mm capillary columns	5181-3323 (10/pk)
	Ferrule, graphite, 0.5-mm id	0.1-mm, 0.2-mm, 0.25-mm, and 0.32-mm capillary columns	5080-8853 (10/pk)
	Ferrule, graphite, 0.4-mm id		500-2114 (10/pk)
	Column nut, finger-tight (for .100- to .320-mm columns)	Connect column to inlet or detector	5020-8292
All	Ferrule, no-hole	Testing	5181-3308 (10/pk)
	Capillary column blanking nut	Testing—use with any ferrule	5020-8294
	Column nut, universal	Connect column to inlet or detector	5181-8830 (2/pk)
	Column cutter, ceramic wafer	Cutting capillary columns	5181-8836 (4/pk)
	Pencil, diamond tipped	Cutting capillary columns	420-1000
	Ferrule tool kit	Ferrule installation	440-1000

## Exploded Parts View of the VI

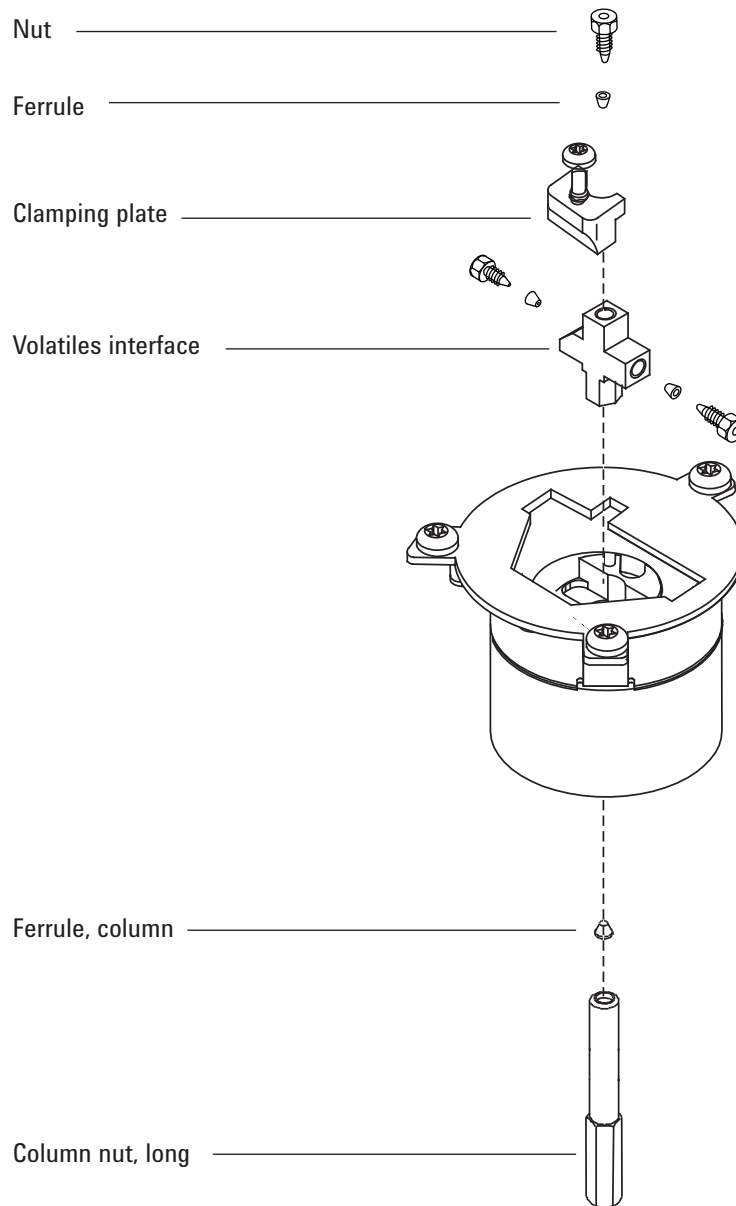

## To Install a Capillary Column with the VI

- 1 Gather the following:
  - Long (65 mm) column nut
  - Column
  - Ferrule
  - Column cutter
  - Isopropanol
  - Septum
  - 1/4-inch wrench
  - Lab tissue
  - Metric ruler
  - Lint-free gloves
- 2 Load the [inlet maintenance method](#) and wait for the GC to become ready.

**WARNING**

**Be careful! The oven and/or inlet may be hot enough to cause burns. If either is hot, wear heat-resistant gloves to protect your hands.**

---

**WARNING**

**Wear safety glasses to protect your eyes from flying particles while handling, cutting, or installing glass or fused silica capillary columns. Use care in handling these columns to prevent puncture wounds.**

---

**CAUTION**

Wear clean, lint-free gloves to prevent contamination of parts with dirt and skin oils.

---

- 3 Place the column on the hanger with the ends pointing up and the label to the front.
- 4 Place a septum, long capillary column nut, and ferrule on the column.

Use a long column nut. (See [“Consumables and Parts for the VI”](#) on page 178.)

If you are using a standard column nut, you must remove the interface. For this reason it is recommended that you use the long column nut. (See “To Remove the VI Interface” on page 185.)

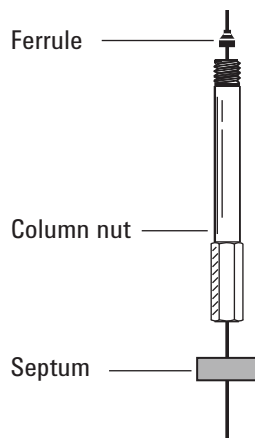

- 5 Score the column using a glass scribing tool. The score must be square to ensure a clean break.

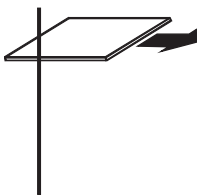

- 6 Break off the column end by supporting it against the column cutter opposite the scribe. Inspect the end with a magnifying loupe to make certain that there are no burrs or jagged edges.

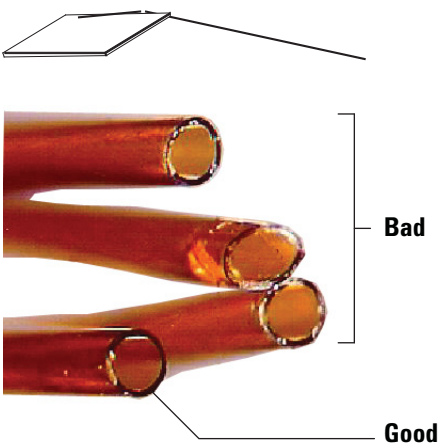

- 7 Wipe the column walls with a tissue dampened with isopropanol to remove fingerprints and dust.

- 8 Position the column so it extends 6 mm above the end of the ferrule. Slide the septum up the column to hold the column nut at this fixed position.

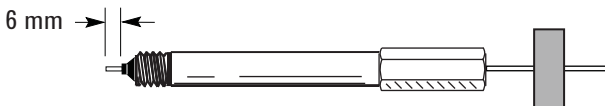

- 9 Insert the column into the interface and finger-tighten the column nut.
- 10 Adjust the column (*not* the septum) position until the septum is snug against the bottom of the nut.
- 11 Tighten the column nut an additional 1/4 to 1/2 turn with a wrench so that the column cannot be pulled from the fitting with gentle pressure.
- 12 Configure the new column. If using the optional barcode scanner, scan the column directly into your data system software configuration, then download the changes to the GC.
- 13 With the sample transfer line attached and the column attached to the inlet and detector, establish a flow of carrier gas through the transfer line. Purge as recommended by the column manufacturer.
- 14 Condition the column per the manufacturer's recommendation. (See [To Condition a Capillary Column.](#))
- 15 Install the column into the detector. See:
- [To Install a Capillary Column in the FID](#)
  - [To Install a Capillary Column in the NPD](#)
  - [To Install a Capillary Column in the TCD](#)
  - [To Install a Capillary Column in the uECD](#)
  - [To install a Capillary Column in the FPD Plus](#)
  - [To Install a Capillary Column Adapter in the FPD](#)
- 16 After the column is installed at both inlet and detector, establish a flow of carrier gas and purge as recommended by the column manufacturer.
- 17 Restore the analytical method.
- For FPD, immediately turn off the flame.
  - For NPD, immediately set the bead voltage to 0.0.
- 18 After the GC becomes ready, wait 10 minutes then ignite the detector flame or adjust offset on the NPD bead.

**WARNING**

**Be careful! The oven, inlet, and/or detector may be hot enough to cause burns. If the oven, inlet, or detector is hot, wear heat-resistant gloves to protect your hands.**

---

- 19 Allow the oven, inlet, and detector to equilibrate at operating temperature, then retighten the fittings.
- 20 Reset the column EMF counters. See [To Reset an EMF Counter](#) in the *Operation Manual*.



## To Remove the VI Interface

- 1 Gather the following:
  - 1/4-inch and 7-mm wrench
  - T-20 Torx screwdriver
- 2 Load the [inlet maintenance method](#) and wait for the GC to become ready.

**WARNING**

**Be careful! The interface may be hot enough to cause burns. If the interface is hot, wear gloves to protect your hands.**

---

- 3 Remove the column.
- 4 Remove the transfer line by loosening the nut, then lift it from the interface.
- 5 Loosen the five inlet cover screws and remove the inlet cover.
- 6 Remove the clamping plate from the interface by loosening the captive screw.

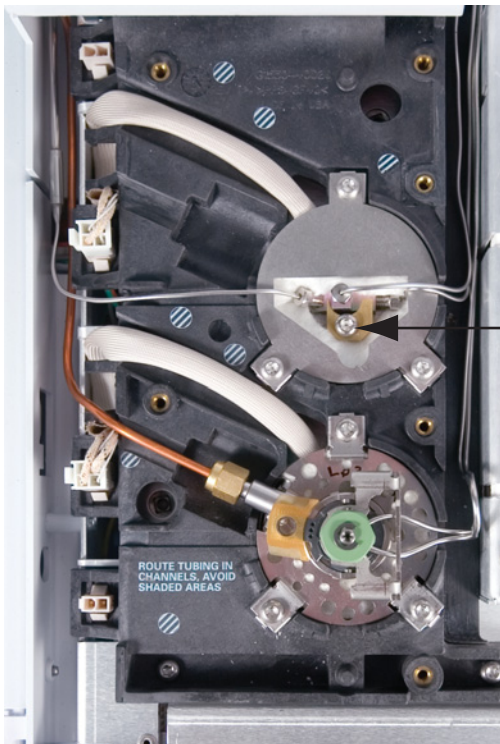

- 7 Lift the interface out of the heater block.

## 10 Maintaining the VI

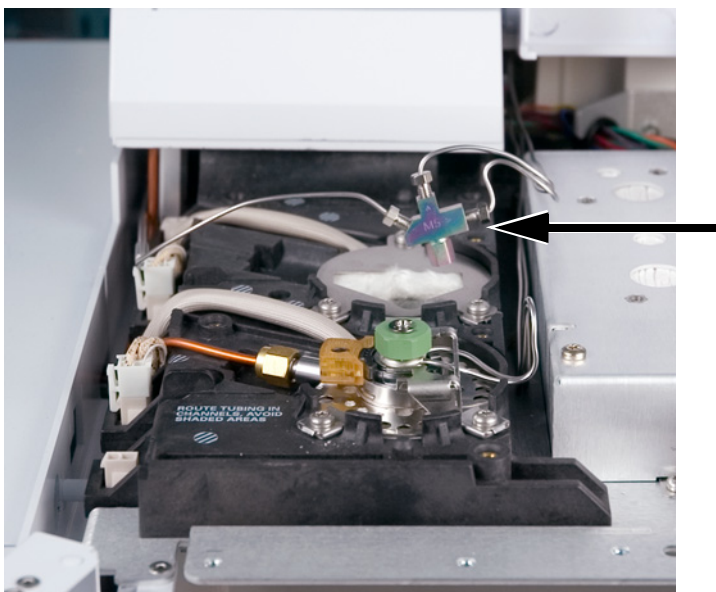

## To Clean the VI

- 1 Gather the following:
  - 1/4-inch and 7-mm wrench
  - T-20 Torx screwdriver
  - Lint-free gloves
- 2 Load the [inlet maintenance method](#) and wait for the GC to become ready.
- 3 Remove the interface. (See [“To Remove the VI Interface”](#) on page 185.)

**WARNING**

**Be careful! The oven and/or inlet may be hot enough to cause burns. If either is hot, wear heat-resistant gloves to protect your hands.**

---

**WARNING**

**The split vent trap and line may contain residual amounts of any samples or other chemicals you have injected into the GC. Follow your company's safety procedures for handling these types of substances.**

---

- 4 Remove the split vent and pressure sensing lines by loosening the nuts.

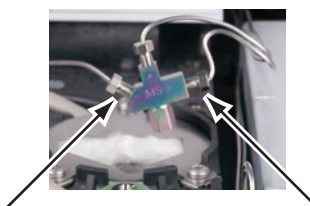
**CAUTION**

**Wear clean, lint-free gloves to prevent contamination of parts with dirt and skin oils.**

---

- 5 Clean the interface using an ultrasonic bath. Sonicate twice, then rinse and air dry.
- 6 Inspect the split vent line. If clogged, contact Agilent for service.

## 10 Maintaining the VI

- 7 Install the interface. (See [“To Install the VI Interface”](#) on page 189.)

## To Install the VI Interface

- 1 Gather the following:
  - 1/4-inch and 7-mm wrench
  - T-20 Torx screwdriver
- 2 Attach the split vent line and pressure sensing lines and finger-tighten the nuts. Tighten an additional 1/4 turn with a wrench.
- 3 Place the interface into the heater block and reseal the tubing as needed.
- 4 Install the clamping plate and tighten the screw.



- 5 Install the inlet cover. Be sure the cover does not damage any tubing.
- 6 Attach the sample transfer line.
- 7 Install the column. (See [“To Install a Capillary Column with the VI”](#) on page 181.)

## To Replace the Filter in the Split Vent Line for the VI

- 1 Gather the following:
  - New filter cartridge. (See “Consumables and Parts for the VI” on page 178.)
  - T-20 Torx screwdriver
- 2 Load the [inlet maintenance method](#) and wait for the GC to become ready.

**WARNING**

**Be careful! The oven and/or inlet may be hot enough to cause burns. If either is hot, wear heat-resistant gloves to protect your hands.**

**WARNING**

**The split vent trap may contain residual amounts of any samples or other chemicals you have injected into the GC. Follow your company’s safety procedures for handling these types of substances while replacing the trap filter cartridge.**

- 3 Remove the [pneumatics cover](#) (top, back of GC).
- 4 Remove the retaining clip.

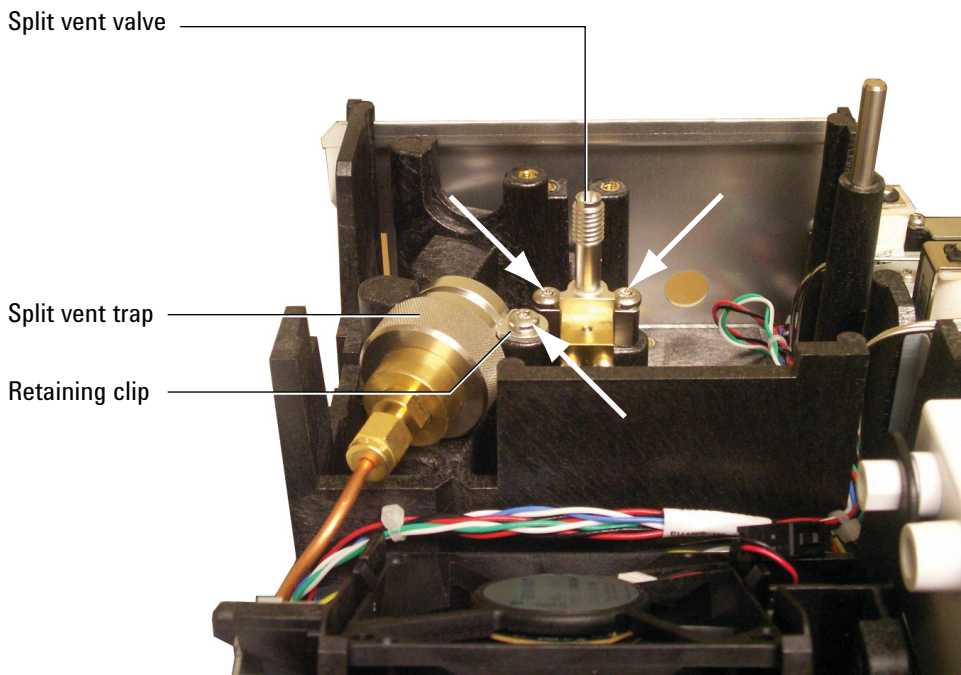

- 5 Completely loosen the two screws that secure the split vent valve in place.
- 6 Lift the filter trap assembly and split vent valve from the mounting bracket together and unscrew the split vent front weldment on the filter trap assembly. Be careful not to stress the tubing between the split vent valve and the trap.

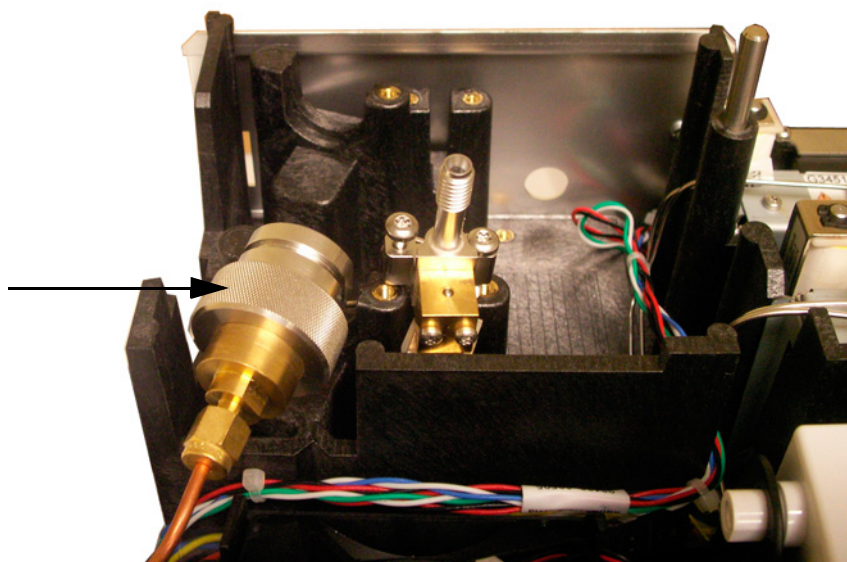

- 7 Remove the old filter cartridge and two O-rings.

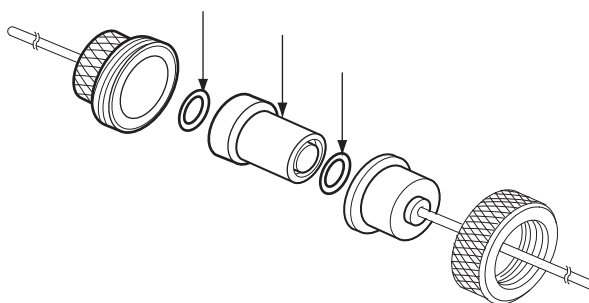

- 8 Verify the new O-rings are seated properly on the new filter cartridge.
- 9 Install the new filter cartridge then reassemble the trap. Do not fully tighten yet.
- 10 Place the filter trap assembly in the mounting bracket and install the retaining clip.
- 11 Install the split vent valve.
- 12 Fully tighten the split vent front weldment onto the trap.
- 13 Check for leaks.

## 10 Maintaining the VI

- 14 Reset the EMF counter. See [To reset an EMF counter](#).
- 15 Restore the analytical method.
- 16 Reset the split vent trap counter.
- 17 Install the pneumatics cover.



## To Bakeout Contaminants from the VI Inlet

- 1 Put the inlet into split mode.
- 2 Set the column flow to the normal operating value, or set the capillary column gas velocity to 30 cm/s.
- 3 Set the inlet split vent flow to 200 mL/min.
- 4 Purge the column with carrier flow for at least 10 minutes before heating the oven.
- 5 If the column is attached to the detector, set the detector 25 °C above normal operating temperature.

**WARNING**

**Be careful! The oven, inlet, and/or detector may be hot enough to cause burns. If they are hot, wear heat-resistant gloves to protect your hands.**

---

If the column is not attached to the detector, cap the detector fitting.

- 6 Set the inlet temperature to 300 °C or 25 °C above the normal operating temperature to bakeout contaminants from the inlet, mostly through the split vent.
- 7 Set the column oven 25 °C above the GC method final oven temperature to bake contaminants from the column. Do not exceed the column manufacturer's maximum temperature limit.
- 8 Bakeout for 30 minutes or until the detector baseline is free of contamination peaks.



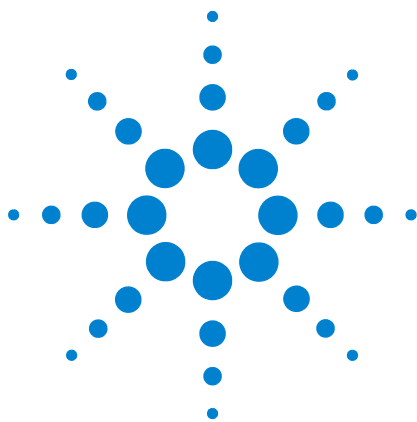

## 11 Maintaining the FID

- Consumables and Parts for the FID [196](#)
- Exploded Parts Views of the FID [199](#)
- Selecting an FID Jet [201](#)
- To Attach a Capillary Column Adapter on an Adaptable FID [203](#)
- To Install a Capillary Column in the FID [205](#)
- To Replace the FID Collector Assembly [209](#)
- To Replace an FID Jet [212](#)
- To Perform Maintenance on the FID Collector Assembly [216](#)
- To Check the FID Leakage Current [224](#)
- To Check the FID Baseline [225](#)
- To Install the FID Insulation Cup Assembly (Adaptable FID Only) [226](#)
- To Install the Optional FID PTFE Chimney Insert [228](#)
- To Bakeout the FID [229](#)



## Consumables and Parts for the FID

See the Agilent catalog for consumables and supplies for a more complete listing, or visit the Agilent Web site for the latest information ([www.agilent.com/chem/supplies](http://www.agilent.com/chem/supplies)).

**Table 27** Nuts, ferrules, and hardware for capillary columns

Column id (mm)	Description	Typical use	Part number/quantity
.530	Ferrule, Vespel/graphite, 0.8-mm id	0.45-mm and 0.53-mm capillary columns	5062-3512 (10/pk)
	Ferrule, graphite, 1.0-mm id	0.53-mm capillary columns	5080-8773 (10/pk)
	Ferrule, graphite, 0.8-mm id	0.53-mm capillary columns	500-2118 (10/pk)
	Column nut, finger-tight (for 0.53-mm columns)	Connect column to inlet or detector	5020-8293
.320	Ferrule, Vespel/graphite, 0.5-mm id	0.32-mm capillary columns	5062-3514 (10/pk)
	Ferrule, graphite, 0.5-mm id	0.1-mm, 0.2-mm, 0.25-mm, and 0.32-mm capillary columns	5080-8853 (10/pk)
	Column nut, finger-tight (for .100- to .320-mm columns)	Connect column to inlet or detector	5020-8292
.250	Ferrule, Vespel/graphite, 0.4-mm id	0.1-mm, 0.2-mm, and 0.25-mm capillary columns	5181-3323 (10/pk)
	Ferrule, graphite, 0.5-mm id	0.1-mm, 0.2-mm, 0.25-mm, and 0.32-mm capillary columns	5080-8853 (10/pk)
	Column nut, finger-tight (for .100- to .320-mm columns)	Connect column to inlet or detector	5020-8292
.100 and .200	Ferrule, Vespel/graphite, 0.37-mm id	0.1-mm and 0.2-mm capillary columns	5062-3516 (10/pk)
	Ferrule, Vespel/graphite, 0.4-mm id	0.1-mm, 0.2-mm, and 0.25-mm capillary columns	5181-3323 (10/pk)
	Ferrule, graphite, 0.5-mm id	0.1-mm, 0.2-mm, 0.25-mm, and 0.32-mm capillary columns	5080-8853 (10/pk)
	Ferrule, graphite, 0.4-mm id		500-2114 (10/pk)
	Column nut, finger-tight (for .100- to .320-mm columns)	Connect column to inlet or detector	5020-8292
All	Ferrule, no-hole	Testing	5181-3308 (10/pk)
	Capillary column blanking nut	Testing—use with any ferrule	5020-8294
	Column nut, universal	Connect column to inlet or detector	5181-8830 (2/pk)

**Table 27** Nuts, ferrules, and hardware for capillary columns (continued)

Column id (mm)	Description	Typical use	Part number/quantity
	Column cutter, ceramic wafer	Cutting capillary columns	5181-8836 (4/pk)
	Pencil, diamond tipped	Cutting capillary columns	420-1000
	Ferrule tool kit	Ferrule installation	440-1000

**Table 28** FID parts and subassemblies

Description	Part number/quantity
Screw, M4 × 25 mm, Torx, T20	0515-2712 (3/pk)
PTFE chimney (optional)	19231-21050
Collector assembly	G1531-60690
FID/NPD capillary column adapter	19244-80610
FID/NPD 1/8-inch packed column adapter	19231-80520
FID/NPD 1/4-inch packed column adapter	19231-80530
Insulation	19234-60715 (1/pk)
Insulation cup assembly	19234-60700
Nut, 1/4-inch, brass, for packed column adapters	5180-4105 (10/pk)
Ferrule, Vespel, 1/4-inch, for packed column adapters	5080-8774 (10/pk)

**Table 29** Jets for capillary adaptable fittings

Jet type	Part number	Jet tip id	Length
Capillary	19244-80560	0.29 mm (0.011 inch)	61.5 mm
Capillary, high-temperature (use with simulated distillation)	19244-80620	0.47 mm (0.018 inch)	61.5 mm
Packed	18710-20119	0.46 mm (0.018 inch)	63.6 mm
Packed, wide-bore (use with high-bleed applications)	18789-80070	0.76 mm (0.030 inch)	63.6 mm

**Table 30** Jets for capillary optimized fittings

Jet type	Part number	Jet tip ID	Length
Capillary	G1531-80560	0.29 mm (0.011 inch)	43 mm
High-temperature (use with simulated distillation)	G1531-80620	0.47 mm (0.018 inch)	48 mm

**Table 31** FID collector assembly parts

<b>Description</b>	<b>Part number/quantity</b>
Screw, M4 × 25 mm, Torx, T20	0515-2712 (3/pk)
Collector assembly	G1531-60690
Collector nut	19231-20940
Spring washer	3050-1246
Ignitor castle	19231-20910
Ignitor castle, Hastelloy	19231-21060
Upper/lower collector insulator	G1531-20700
Collector body	G1531-20690
Collector body, Hastelloy	G1531-21090
Spanner nut (collector)	19231-20980
Collector mount	G1531-20550
Collector housing	G1531-20740
Gasket	5180-4165 (12/pk)
Ignitor (glow plug) assembly with O-ring	19231-60680

## Exploded Parts Views of the FID

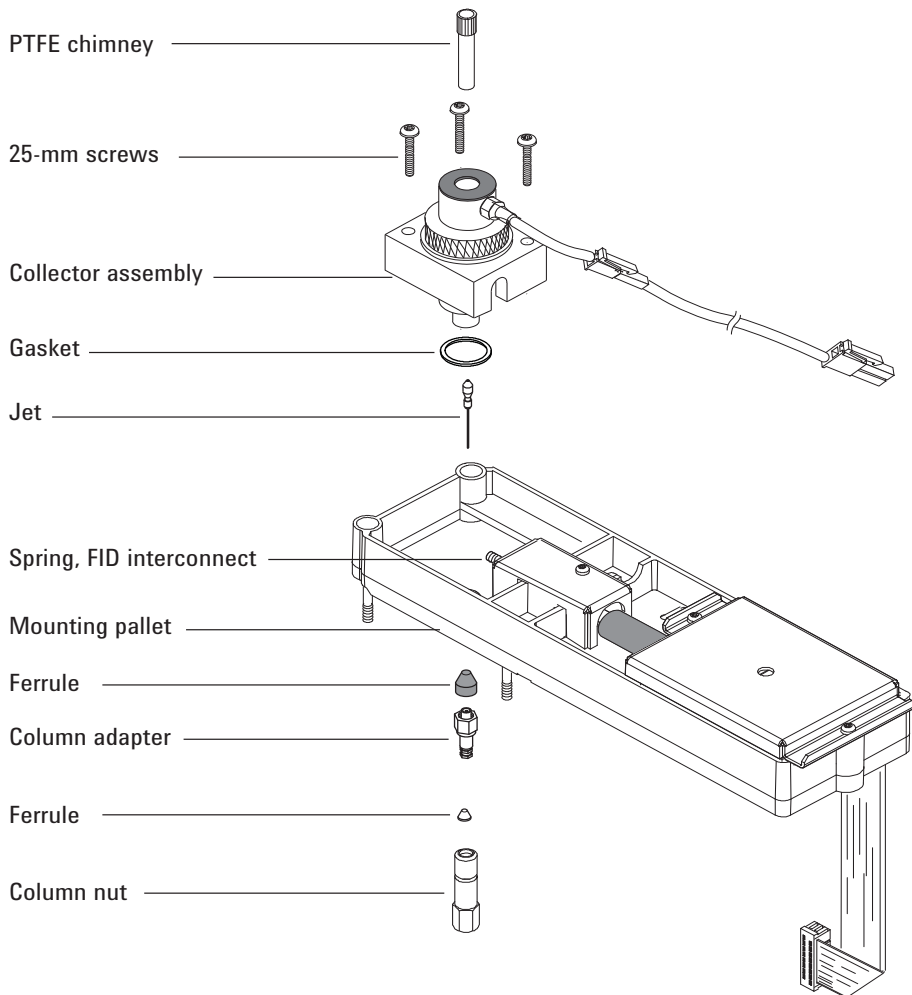

# 11 Maintaining the FID

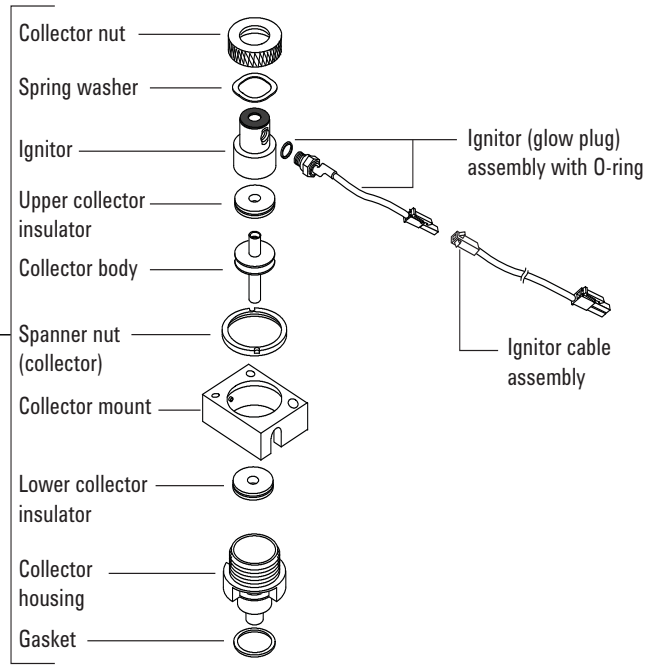
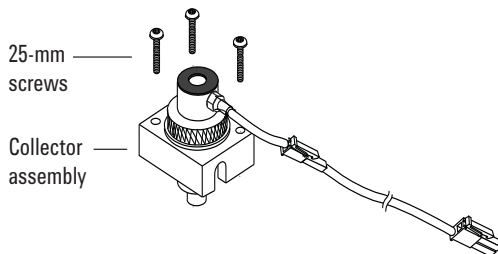
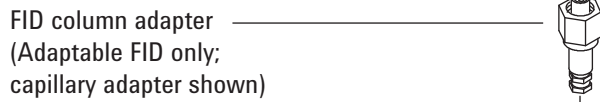
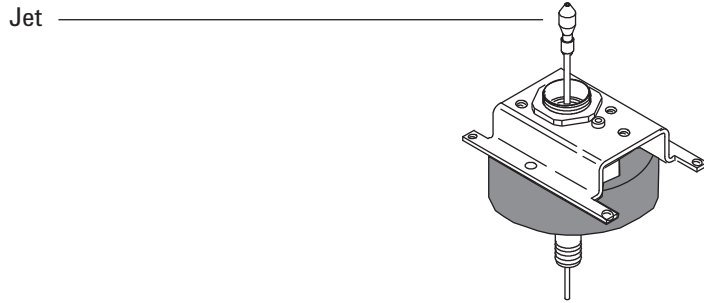



## Selecting an FID Jet

Open the oven door and locate the column connection fitting at the base of the detector. It will look like either a capillary optimized fitting or an adaptable fitting.

Capillary optimized fitting

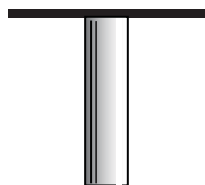

Adaptable fitting



- If you have an application that tends to clog the jet, select a jet with a wider tip id.
- When using packed columns in high column-bleed applications, the jet tends to clog with silicon dioxide.
- In simulated distillation applications, the high-boiling hydrocarbons tend to clog the jet.

For capillary optimized fittings, select a jet from [Table 32](#). For adaptable fittings, select a jet from [Table 33](#).

**Table 32** Jets for capillary optimized fittings

Figure 1 ID	Jet type	Part number	Jet tip id	Length
1	Capillary	G1531-80560	0.29 mm (0.011 inch)	43 mm
2	High-temperature (use with simulated distillation)	G1531-80620	0.47 mm (0.018 inch)	48 mm



**Figure 3** Capillary optimized jets

## 11 Maintaining the FID

**Table 33** Jets for capillary adaptable fittings

Figure 2 ID	Jet type	Part number	Jet tip id	Length
1	Capillary	19244-80560	0.29 mm (0.011 inch)	61.5 mm
2	Capillary, high-temperature (use with simulated distillation)	19244-80620	0.47 mm (0.018 inch)	61.5 mm
3	Packed	18710-20119	0.46 mm (0.018 inch)	63.6 mm
4	Packed, wide-bore (use with high-bleed applications)	18789-80070	0.76 mm (0.030 inch)	63.6 mm



**Figure 4** Capillary adaptable jets

## To Attach a Capillary Column Adapter on an Adaptable FID

- 1 Gather the following materials:
  - Adapter (See “Consumables and Parts for the FID” on page 196.)
  - 1/4-inch brass nut
  - 1/4-inch Vespel/graphite ferrule
  - Column cutter
  - 1/4-inch wrench
  - 9/16-inch open-end wrench
  - Lint-free gloves
- 2 Load the [GC maintenance method](#) and wait for the GC to become ready.

### WARNING

**Be careful! The oven, inlet, and/or detector may be hot enough to cause burns. If the oven, inlet, or detector is hot, wear heat-resistant gloves to protect your hands.**

### CAUTION

Wear clean, lint-free gloves to prevent contamination of parts with dirt and skin oils.

- 3 Assemble the nut and ferrule onto the adapter.

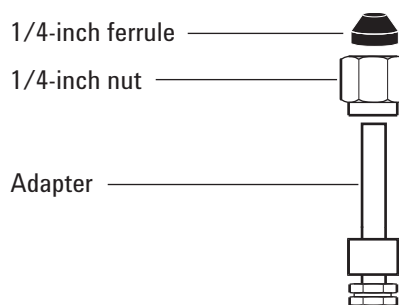

- 4 Insert the adapter straight into the detector base as far as possible.
- 5 Hold the adapter in this position and finger-tighten the nut.

## 11 Maintaining the FID

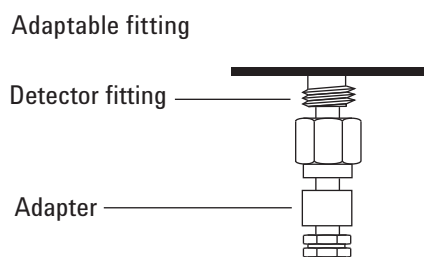

**6** Tighten an additional 1/4 turn with a wrench.

## To Install a Capillary Column in the FID

- 1 Gather the following materials (see [“Consumables and Parts for the FID”](#) on page 196.):
  - Column
  - Ferrule(s)
  - Column nut
  - Column cutter
  - 1/4-inch open-end wrench
  - Septum
  - Isopropanol
  - Lab tissue
  - Lint-free gloves
- 2 Load the [GC maintenance method](#) and wait for the GC to become ready.

**WARNING**

**Be careful! The oven, inlet, and/or detector may be hot enough to cause burns. If the oven, inlet, or detector is hot, wear heat-resistant gloves to protect your hands.**

---

**WARNING**

**Wear safety glasses to protect your eyes from flying particles while handling, cutting, or installing glass or fused silica capillary columns. Use care in handling these columns to prevent puncture wounds.**

---

- 3 If using the adaptable detector, verify that the adapter is installed. (See [“To Attach a Capillary Column Adapter on an Adaptable FID”](#) on page 203.)



**CAUTION**

Wear clean, lint-free gloves to prevent contamination of parts with dirt and skin oils.

- 4 Place a septum (if the column id is  $\leq 0.1$  mm), capillary column nut, and ferrule on the column.

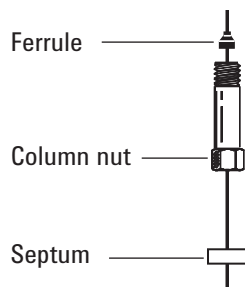

- 5 Score the column using a glass scribing tool. The score must be square to ensure a clean break.

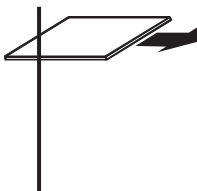

- 6 Break off the column end by supporting it against the column cutter opposite the scribe. Inspect the end with a magnifying loupe to make certain there are no burrs or jagged edges.

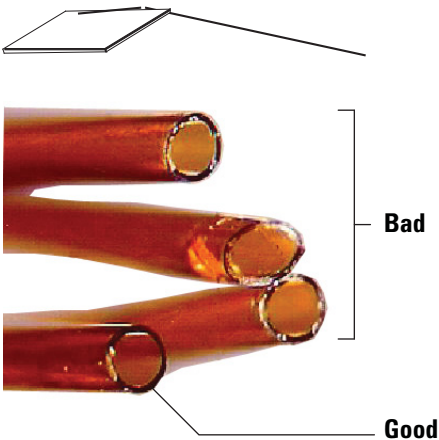

- 7 Wipe the column walls with a tissue dampened with isopropanol to remove fingerprints and dust.
- 8 Install the capillary column.

If the column id is greater than 0.1 mm:

- a Gently insert the column into the detector until it bottoms; do not attempt to force it further.
- b Finger-tighten the column nut, then withdraw the column about 1 mm. Tighten the nut an additional 1/4 turn with a wrench.

If the column id is 0.1 mm or less position the column so it extends above the ferrule by 48 mm (*capillary optimized fitting*) or 68 mm (*adaptable fitting*). Slide the septum up to hold the column nut and ferrule at this fixed position.

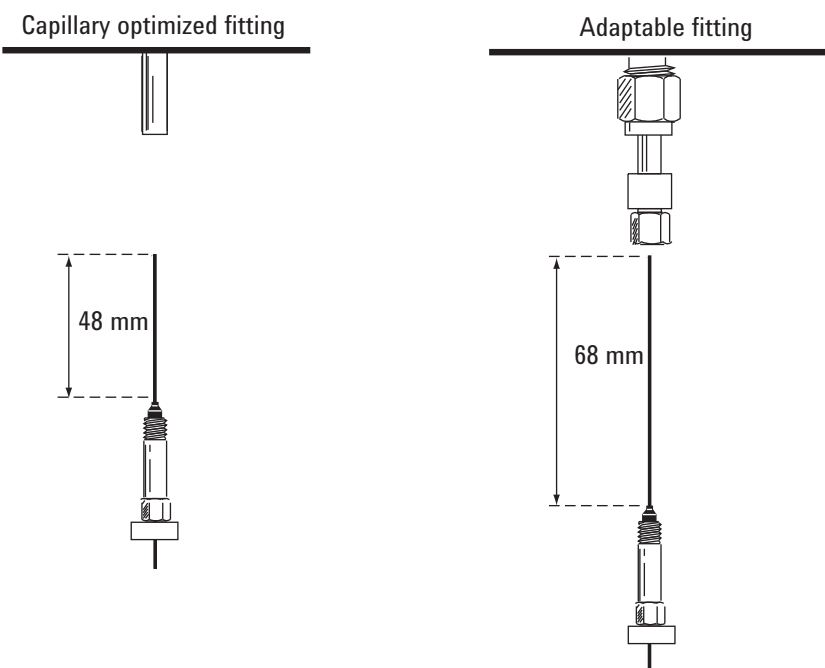

- c Insert the column into the detector. Slide the nut and ferrule up the column to the detector base. Finger-tighten the column nut until it grips the column.
- d Adjust the column (*not* the septum) position so that the septum is even with the bottom of the column nut. Tighten the nut an additional 1/4 turn with a wrench.

## 11 Maintaining the FID

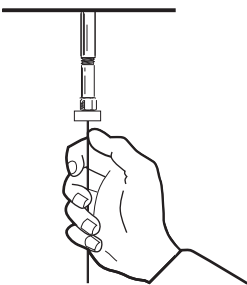



## To Replace the FID Collector Assembly

- 1 Gather the following:
  - New FID collector assembly. (See “Consumables and Parts for the FID” on page 196.)
  - T-20 Torx screwdriver
  - 1/4-inch nut driver
  - Tweezers
  - Lint-free gloves

**CAUTION**

To avoid contaminating the FID, wear clean, lint-free gloves when handling the collector assembly.

---

- 2 Load the [GC maintenance method](#) and wait for the GC to become ready.
- 3 Disconnect the ignitor cable assembly.

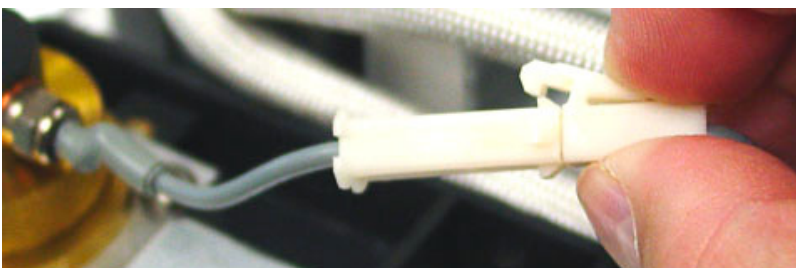

- 4 Remove the three screws holding the collector assembly to the mounting pallet.

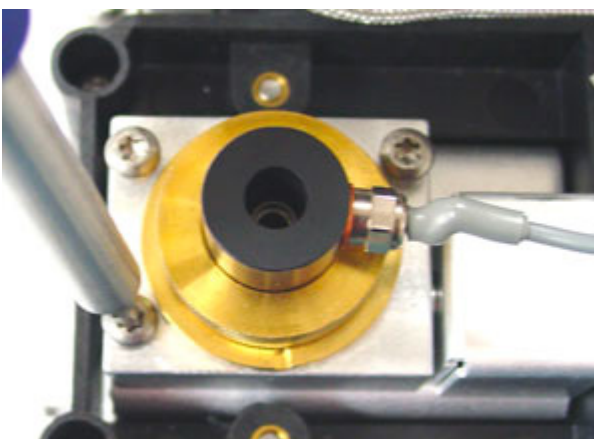

**CAUTION**

This step exposes the interconnect spring. Be careful not to touch or disfigure the spring while working on the FID. Any dirt or bending will reduce the sensitivity of your detector.

- 5 Lift and remove the assembly from the pallet.

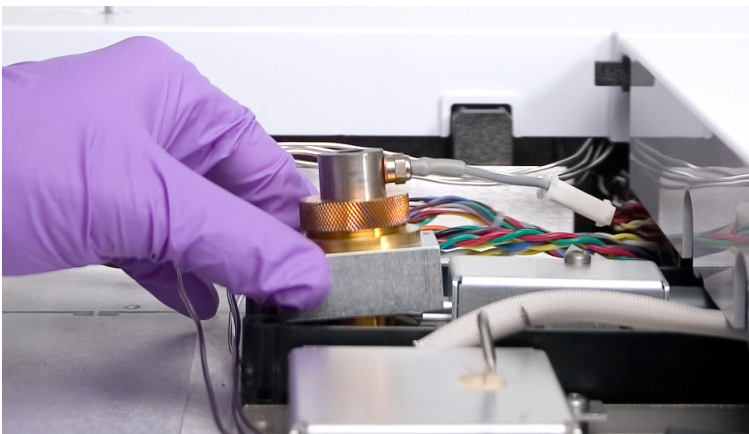

- 6 Remove the ignitor cable assembly from the new collector assembly, if present.
- 7 Remove any protective caps from the new collector assembly, if present.
- 8 Lower the new collector assembly into the housing.
- 9 Insert the three screws and tighten (to 18 inch-pounds).

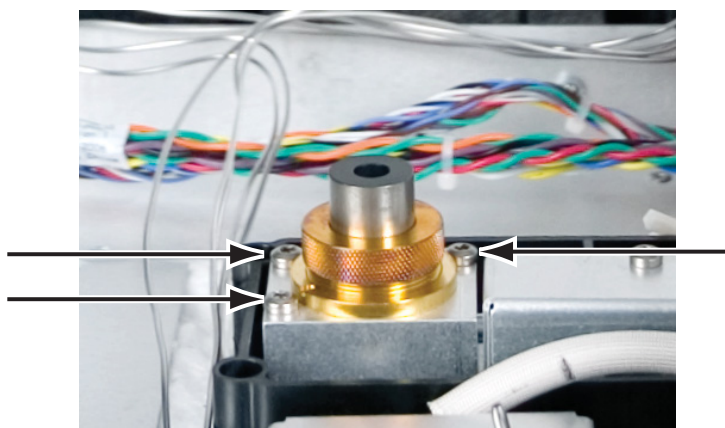

- 10 Connect the ignitor extension cable.
- 11 Verify assembly:
  - a Check the FID leakage current. (See [“To Check the FID Leakage Current”](#) on page 224.)
  - b Check the FID baseline. (See [“To Check the FID Baseline”](#) on page 225.)

- 12 Reset the EMF counter. See [To Reset an EMF Counter](#) in the *Operation Manual*.

## To Replace an FID Jet

- 1 Gather the following:
  - Replacement jet (See [“Selecting an FID Jet”](#) on page 201.)
  - T-20 Torx screwdriver
  - 1/4-inch nut driver
  - Tweezers
  - Compressed, filtered, dry air or nitrogen
  - Solvent that will clean the type of deposits in your detector
  - Clean cloth
  - Cotton swab
  - Lint-free gloves
- 2 Load the [GC maintenance method](#) and wait for the GC to become ready.

**WARNING**

**Be careful! The oven and/or detector may be hot enough to cause burns. If the detector is hot, wear gloves to protect your hands.**

---

**WARNING**

**Wear safety glasses to protect your eyes from flying particles while handling, cutting, or installing glass or fused silica capillary columns. Use care in handling these columns to prevent puncture wounds.**

---

- 3 If installed, remove the capillary column from the detector.

**CAUTION**

Wear clean, lint-free gloves to prevent contamination of parts with dirt and skin oils.

---

- 4 Remove the FID collector assembly and place it on a clean cloth. (See [“To Replace the FID Collector Assembly”](#) on page 209.)

- 5 Locate the jet inside the housing.

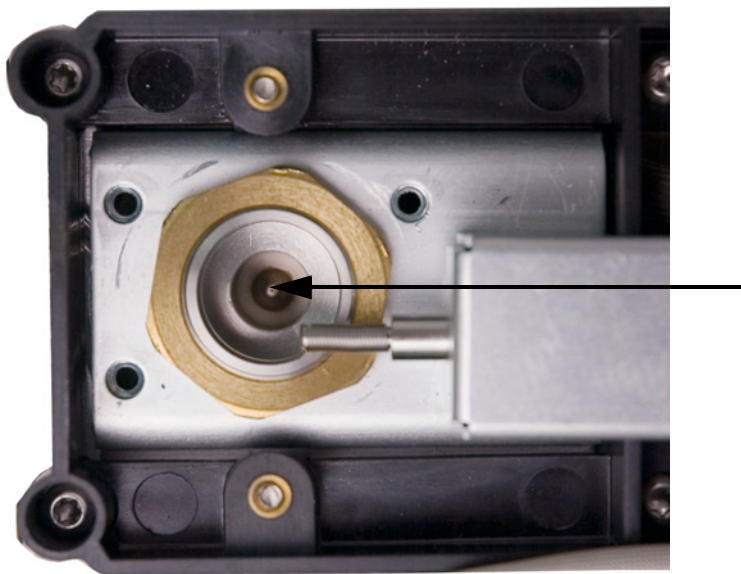

**CAUTION**

Handle the clean or new jet only with tweezers, or wear gloves.

- 6 Loosen the jet, then lift it out of the housing with tweezers.

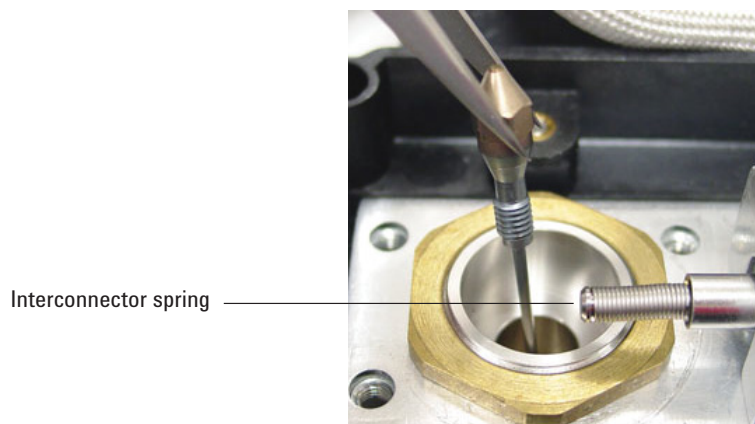

- 7 Clean the detector base cavity using solvent, a swab, and compressed air or nitrogen.
- 8 Use tweezers to lower the new jet into the housing.

### CAUTION

Do not overtighten the jet! Overtightening may permanently deform and damage the jet, the detector base, or both. The torque specification is 10 inch-pounds.

- 9 Carefully screw the jet into the housing. Tighten 1/6-turn past finger-tight (1/6-turn is one “flat” on a typical screwdriver handle, or the jet head).

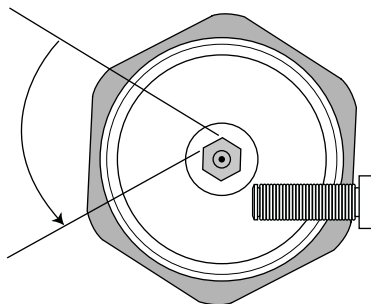
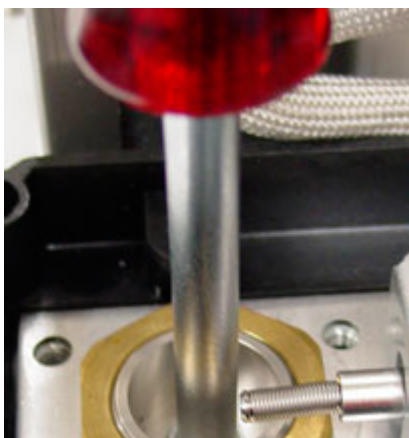

- 10 Install the collector assembly. (See [“To Replace the FID Collector Assembly”](#) on page 209.)
- 11 Reset the jet counter. See [To Reset an EMF Counter](#) in the *Operation Manual*.
- 12 Attach the capillary column to the detector.
  - a Install the column in the detector. (See [“To Install a Capillary Column in the FID”](#) on page 205.)
  - b After the column is installed at both inlet and detector, establish a flow of carrier gas and purge as recommended by the column manufacturer.
  - c Check the FID leakage current. (See [“To Check the FID Leakage Current”](#) on page 224.)
  - d Bakeout the detector. (See [“To Bakeout the FID”](#) on page 229.)
  - e Restore the analytical method.

### WARNING

Be careful! The oven, inlet, and/or detector may be hot enough to cause burns. If the oven, inlet, or detector is hot, wear heat-resistant gloves to protect your hands.

- f** Allow the oven, inlet, and detector to equilibrate at operating temperature, then retighten the fittings.
- 13** Check the FID baseline. (See [“To Check the FID Baseline”](#) on page 225.)

## To Perform Maintenance on the FID Collector Assembly

**NOTE**

Perform only the steps and gather only the parts that apply to the desired maintenance task(s).

---

**1** Gather the following:

- Replacement ignitor assembly (See “Consumables and Parts for the FID” on page 196.)
- Replacement ignitor castle
- Two collector insulators
- Collector
- Spring washer
- Gasket
- T-20 Torx screwdriver
- 1/4-inch nut driver
- Tweezers
- 5/16-inch wrench
- Lint-free gloves
- Clean cloth

**CAUTION**

To avoid contaminating the FID, wear clean, lint-free gloves when handling the collector assembly.

---

- 2** Load the [GC maintenance method](#) and wait for the GC to become ready.

**WARNING**

**Be careful! The oven and/or detector may be hot enough to cause burns. If the detector is hot, wear gloves to protect your hands.**

---



- 3 Remove the FID ignitor.
  - a Disconnect the ignitor cable assembly.

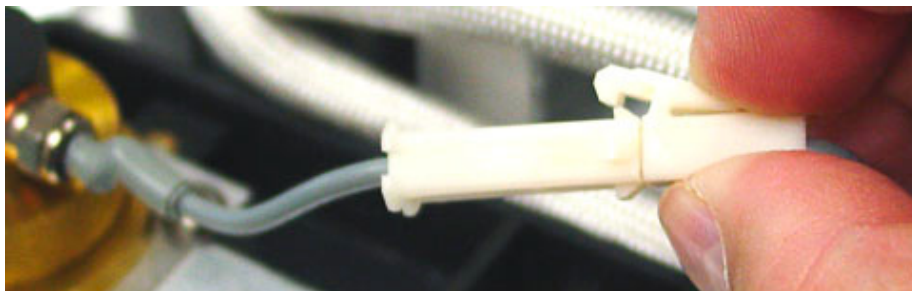

- b Loosen the ignitor with a wrench.



- c Turn the nut counterclockwise by hand. Remove the ignitor and copper washer.
- 4 If replacing only the FID ignitor assembly with copper washer, skip to [step 16](#) for assembly.
- 5 Remove the three screws that hold the collector mount to the FID thermal strap.

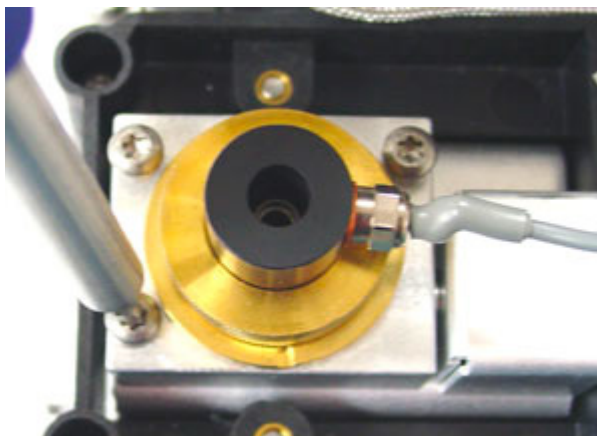

### CAUTION

This step exposes the interconnect spring. Be careful not to touch or disfigure the spring while working on the FID. Any dirt or bending will reduce the sensitivity of your detector.

- 6 Remove the collector assembly. Place it on a clean cloth for additional disassembly.



- 7 Remove the gasket from the bottom of the assembly, if necessary.
- 8 Remove the FID ignitor castle.
  - a Loosen the collector nut.
  - b Remove the collector nut and the spring washer.



- c Lift the castle out of the collector housing. When removing the castle, some of the collector parts may be attached. Set these on a clean cloth to protect from scratches or dirt.



**9** If only replacing the FID castle, skip to [step 15](#) for reassembly.

**10** Remove the collector and insulators.

- a** If needed, remove the collector and upper insulator from the FID housing. The lower insulator may come out with the collector, but often remains in the FID housing. Place the parts on a clean cloth.

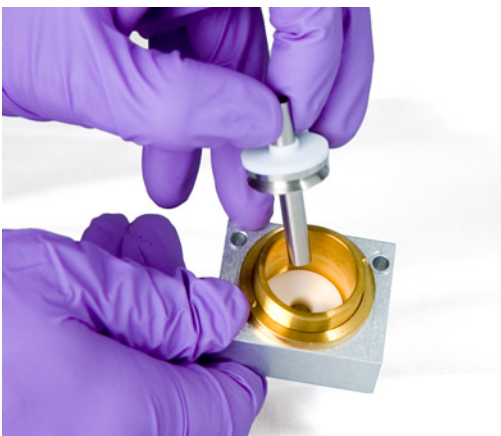

- b** Remove the lower insulator with tweezers and place the parts on a clean cloth.

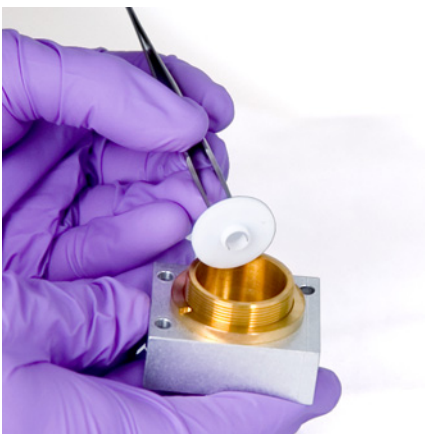

**11** Remove the collector housing from the mount, if necessary.

**12** Use tweezers to remove the gasket from the bottom of the housing.

The collector assembly is now completely disassembled.  
Reassemble as follows:

**13** Use tweezers to install a new gasket onto the housing, being sure that it lays flat on the brass surface.

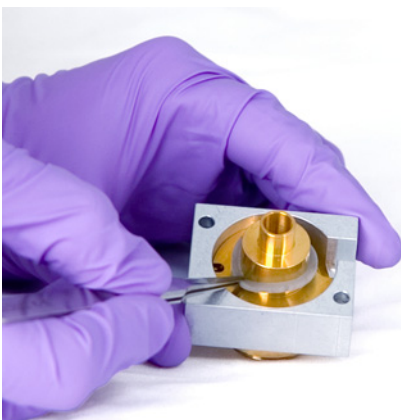

**14** Install the collector insulators.

**a** Insert one of the insulators into the base of the housing. Seat the insulator with the flat surface facing out of the housing.

**b** Insert the long end of collector into the housing and lower insulator.

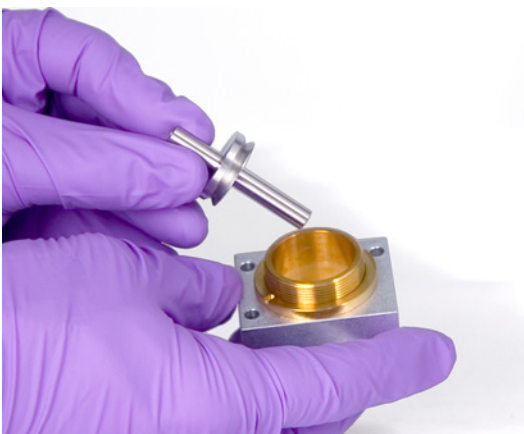

- c Insert the other insulator onto the top of the collector, with the flat surface facing towards the housing.

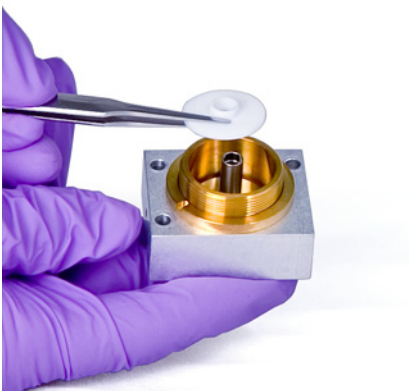

**15** Install the FID ignitor castle.

- a Orient the castle so that the threaded hole for the ignitor faces toward the electronics.



- b Insert the FID castle into the collector housing.
- c Install the spring washer over the castle.

## 11 Maintaining the FID



- d** Install the collector nut over the castle and tighten firmly. The seal should be airtight. Maintain the orientation of the ignitor hole with the base as shown below.

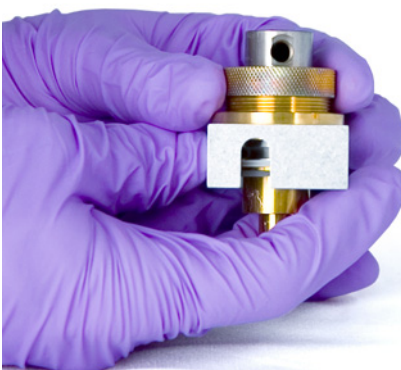

### 16 Install the FID ignitor.

- a** Insert the ignitor and copper seal into the threaded hole of the castle. Keep the mating threads clean.



- b** Tighten the ignitor with a wrench. Ignition requires a good electrical contact that is free of any dirt.

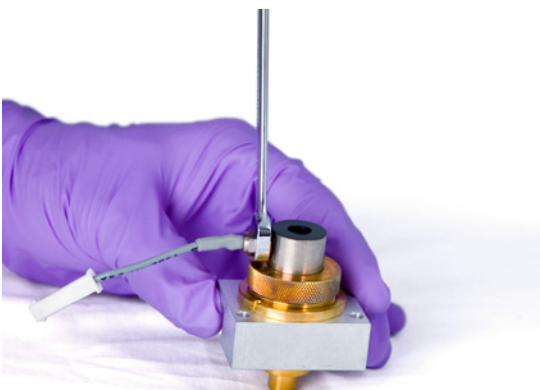

- 17** Lower the collector assembly into the housing.
- 18** Insert the three screws and tighten (to 18 inch-pounds).

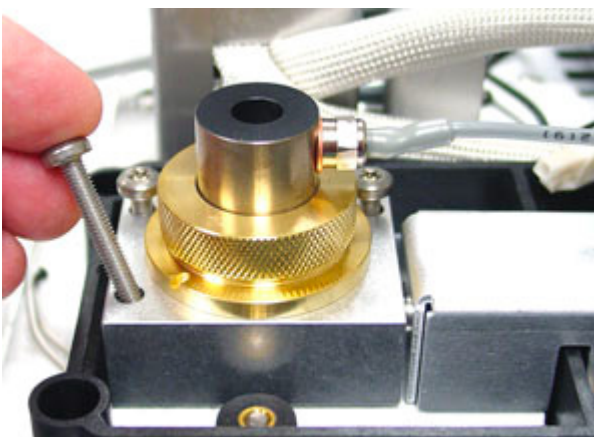

- 19** Connect the ignitor extension cable.
- 20** Verify assembly:
- a** Check the FID leakage current. (See [“To Check the FID Leakage Current”](#) on page 224.)
  - b** Bakeout the detector. (See [“To Bakeout the FID”](#) on page 229.)
  - c** Check the FID baseline. (See [“To Check the FID Baseline”](#) on page 225.)
- 21** Reset the EMF counters. See [To Reset an EMF Counter](#) in the *Operation Manual*.

## To Check the FID Leakage Current

- 1 Load the analytical method.
  - Make sure flows are acceptable for ignition.
  - Heat the detector to operating temperature or 300 °C.
- 2 Turn off the FID flame.
- 3 Press **[Front Detector]** or **[Back Detector]**, then scroll to **Output**.
- 4 Verify that the output is stable and  $< 1.0$  pA.

If the output is unstable or  $> 1.0$  pA, turn off the GC and check for proper assembly of the upper FID parts and contamination. If this contamination is confined to the detector, bakeout the FID. (See “[To Bakeout the FID](#)” on page 229.)

- 5 Turn on the flame.



## To Check the FID Baseline

- 1 With the column installed, load your checkout method.
- 2 Set the oven temperature to 35 °C.
- 3 Press [**Front Detector**] or [**Back Detector**], then scroll to **Output**.
- 4 When the flame is lit and the GC is ready, verify that the output is stable and < 20 pA.

If the output is not stable or > 20 pA, the system or gas may be contaminated. If this contamination is isolated to the detector, then bakeout the FID. (See [“To Bakeout the FID”](#) on page 229.)

## To Install the FID Insulation Cup Assembly (Adaptable FID Only)

- 1 Gather the following:
  - Insulation (See “Consumables and Parts for the FID” on page 196.)
  - Insulation cup assembly
- 2 Load the [GC maintenance method](#) and wait for the GC to become ready.

**WARNING**

**Be careful! The detector may be hot enough to cause burns. If the detector is hot, wear heat-resistant gloves to protect your hands.**

---

- 3 Assemble the insulation in the cup. Line up the slots in the insulation with the slot in the cup.

Capillary columns should be attached to the detector before installing the cup. When attaching a packed column to the detector, cap the detector fitting before installing the cup to prevent insulation contamination of the detector.



- 4 Push the wire spring lever to the right to uncover the hole.

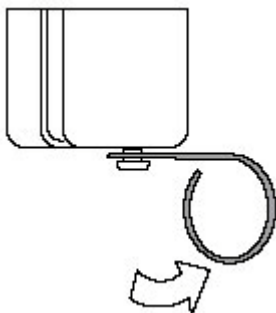

- 5 From inside the oven with the column installed, pass the column through the slot in the cup. Move the cup up over the detector fitting so that the cup touches the top of the oven. You should be able to see the groove in the fitting.
- 6 Release the spring into the groove of the fitting.

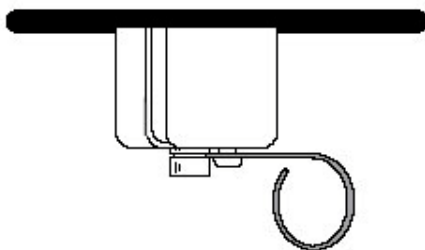

## To Install the Optional FID PTFE Chimney Insert

**WARNING**

Be careful! The detector may be hot enough to cause burns. If the detector is hot, wear heat-resistant gloves to protect your hands.

---

- 1 Light the FID flame.
- 2 Insert the PTFE chimney into the FID castle.



**NOTE**

When installed, the PTFE chimney insert prevents ignition.

---

## To Bakeout the FID

**WARNING**

If using hydrogen as a carrier gas, turn off the hydrogen supply and cap the end of the column to prevent an oven explosion.

---

- 1 Bakeout the FID with the column installed or uninstalled. If uninstalled, gather the following (see “Consumables and Parts for the FID” on page 196):
  - Capillary adapter (adaptable FID only)
  - Column nut
  - No-hole ferrule
- 2 Load the [GC maintenance method](#) and wait for the GC to become ready.

**WARNING**

Be careful! The detector may be hot enough to cause burns. If the detector is hot, wear heat-resistant gloves to protect your hands.

---

- 3 If the column is uninstalled, plug the detector connection with the capillary adapter, column nut, and no-hole ferrule.

Maintain inert carrier gas flow through the column, or remove the column from the GC.
- 4 Set the detector temperature at 350 to 375 °C.
- 5 Set normal operating flows.
- 6 Light the FID flame.
- 7 Set the oven temperature to 250 °C or 25 °C above the normal maximum operating temperature. Do not exceed the column’s temperature limit.

- 8 Hold at temperature for 30 minutes or until the baseline settles at a lower value. The baseline will typically rise, then fall to a final value lower than the initial baseline.

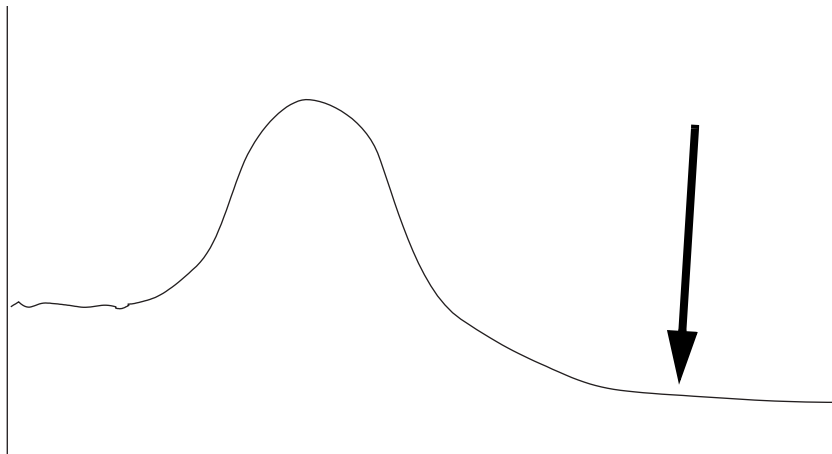

- 9 Restore the analytical method and allow the FID to equilibrate.
- 10 Check the FID output value. It should be lower than the first reading. If it is not, contact your Agilent service representative.  
  
Without a column installed, a clean system baseline should be  $<20$  pA.
- 11 If the column is not installed in the FID, install it. (See [“To Install a Capillary Column in the FID”](#) on page 205.)

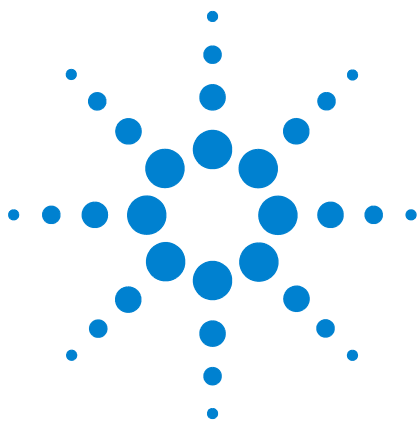

## 12 Maintaining the TCD

Consumables and Parts for the TCD [232](#)

To Install a Capillary Column in the TCD [234](#)

To Install the Optional TCD Capillary Column Adapter [236](#)

To Install a Capillary Column with the Optional TCD Capillary Column Adapter [237](#)

To Bakeout Contaminants from the TCD [240](#)



## Consumables and Parts for the TCD

See the Agilent catalog for consumables and supplies for a more complete listing, or visit the Agilent Web site for the latest information ([www.agilent.com/chem/supplies](http://www.agilent.com/chem/supplies)).

### Standard TCD column hardware

**Table 34** Standard parts for attaching columns to the TCD

Column	Description	Unit	Part number
Capillary	Nut, 1/8-inch id, brass Swagelok	10/pk	5180-4103
	Back ferrule, for 0.1-mm to 0.53-mm capillary columns	10/pk	5182-3477
	Front ferrule, 0.53-mm capillary columns	10/pk	5182-9673
	Front ferrule, 0.32-mm capillary columns	10/pk	5182-9676
	Front ferrule, 0.1-mm, 0.2-mm, and 0.25-mm capillary columns	10/pk	5182-9677
	1/8-inch Swagelok plug		5180-4124
1/4-inch packed	1/4-inch packed column adapter		G1532-20710
	1/8-inch id Vespel/graphite ferrule	10/pk	0100-1332
	Nut, 1/8-inch id, brass	10/pk	5180-4103
	Ferrule, Vespel, 1/4-inch	10/pk	5080-8774
	1/4-inch id tubing nut, brass	10/pk	5180-4105
	1/8-inch Swagelok plug		5180-4124
1/8-inch packed	Ferrule, 1/8-inch Vespel/graphite	10/pk	0100-1332
	Nut, 1/8-inch id, brass	10/pk	5180-4103
	1/8-inch Swagelok plug		5180-4124

### Optional TCD capillary column hardware

**Table 35** Optional TCD capillary column adapter hardware

Description	Unit	Part number
Capillary adapter		G1532-80540
Ferrule, Vespel, 1/8-inch	10/pk	0100-1332
Nut, brass, 1/8-inch	10/pk	5180-4103



**Table 36** Nuts, ferrules, and hardware for capillary columns

Column id (mm)	Description	Typical use	Part number/quantity
.530	Ferrule, Vespel/graphite, 0.8-mm id	0.45-mm and 0.53-mm capillary columns	5062-3512 (10/pk)
	Ferrule, graphite, 1.0-mm id	0.53-mm capillary columns	5080-8773 (10/pk)
	Ferrule, graphite, 0.8-mm id	0.53-mm capillary columns	500-2118 (10/pk)
	Column nut, finger-tight (for 0.53-mm columns)	Connect column to inlet or detector	5020-8293
.320	Ferrule, Vespel/graphite, 0.5-mm id	0.32-mm capillary columns	5062-3514 (10/pk)
	Ferrule, graphite, 0.5-mm id	0.1-mm, 0.2-mm, 0.25-mm, and 0.32-mm capillary columns	5080-8853 (10/pk)
	Column nut, finger-tight (for .100- to .320-mm columns)	Connect column to inlet or detector	5020-8292
.250	Ferrule, Vespel/graphite, 0.4-mm id	0.1-mm, 0.2-mm, and 0.25-mm capillary columns	5181-3323 (10/pk)
	Ferrule, graphite, 0.5-mm id	0.1-mm, 0.2-mm, 0.25-mm, and 0.32-mm capillary columns	5080-8853 (10/pk)
	Column nut, finger-tight (for .100- to .320-mm columns)	Connect column to inlet or detector	5020-8292
.100 and .200	Ferrule, Vespel/graphite, 0.37-mm id	0.1-mm and 0.2-mm capillary columns	5062-3516 (10/pk)
	Ferrule, Vespel/graphite, 0.4-mm id	0.1-mm, 0.2-mm, and 0.25-mm capillary columns	5181-3323 (10/pk)
	Ferrule, graphite, 0.5-mm id	0.1-mm, 0.2-mm, 0.25-mm, and 0.32-mm capillary columns	5080-8853 (10/pk)
	Ferrule, graphite, 0.4-mm id		500-2114 (10/pk)
	Column nut, finger-tight (for .100- to .320-mm columns)	Connect column to inlet or detector	5020-8292
All	Ferrule, no-hole	Testing	5181-3308 (10/pk)
	Capillary column blanking nut	Testing—use with any ferrule	5020-8294
	Column nut, universal	Connect column to inlet or detector	5181-8830 (2/pk)
	Column cutter, ceramic wafer	Cutting capillary columns	5181-8836 (4/pk)
	Pencil, diamond tipped	Cutting capillary columns	420-1000
	Ferrule tool kit	Ferrule installation	440-1000

## To Install a Capillary Column in the TCD

- 1 Gather the following:
  - Front ferrule (See “Consumables and Parts for the TCD” on page 232.)
  - Back ferrule
  - Column nut
  - Column cutter
  - 7/16-inch wrench
  - Lab tissue
  - Lint-free gloves
- 2 Load the [GC maintenance method](#) and wait for the GC to become ready.

**WARNING**

**Be careful! The oven and/or inlet may be hot enough to cause burns. If the inlet is hot, wear heat-resistant gloves to protect your hands.**

---

**WARNING**

**Wear safety glasses to protect your eyes from flying particles while handling, cutting, or installing glass or fused silica capillary columns. Use care in handling these columns to prevent puncture wounds.**

---

**CAUTION**

**Wear clean, lint-free gloves to prevent contamination of parts with dirt and skin oils.**

---

- 3 Assemble the ferrules and 1/8-inch brass Swagelok nut on the column.

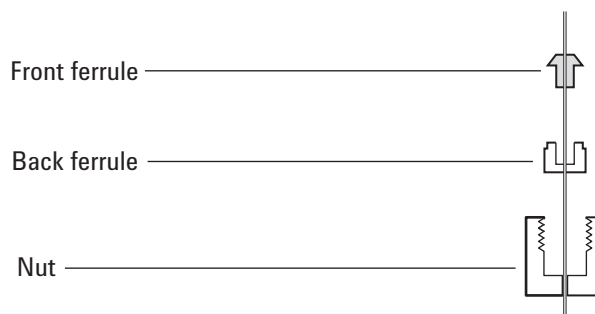

- 4 Score the column using a glass scribing tool. The score must be square to ensure a clean break.

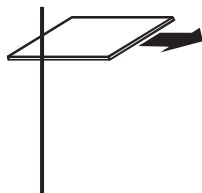

- 5 Break off the column end by supporting it against the column cutter opposite the scribe. Inspect the end with a magnifying loupe to make certain that there are no burrs or jagged edges.

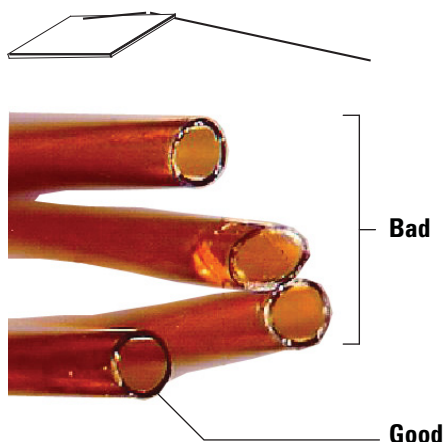

- 6 Wipe the column walls with a tissue dampened with isopropanol to remove fingerprints and dust.
- 7 Insert the column into the detector until it bottoms.
- 8 Slide the column nut and ferrules up the column to the detector and finger-tighten the nut.
- 9 Pull out 1 mm of column. Tighten the nut an additional 1/4 turn with a wrench or until the column does not move.

## To Install the Optional TCD Capillary Column Adapter

- 1 Gather the following:
  - Capillary column adapter (See “Consumables and Parts for the TCD” on page 232.)
  - 1/4-inch and 7/16-inch wrenches
  - 1/8-inch brass nut
  - 1/8-inch Vespel ferrule
  - Lint-free gloves
- 2 Load the [GC maintenance method](#) and wait for the GC to become ready.

**CAUTION**

Wear clean, lint-free gloves to prevent contamination of parts with dirt and skin oils.

- 3 Assemble the brass nut and ferrule onto the capillary column adapter.

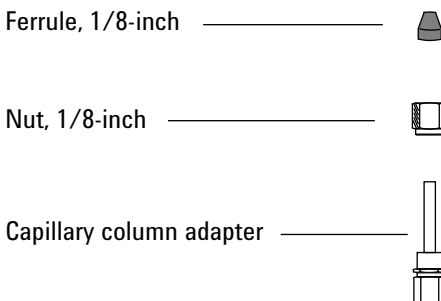

- 4 Install the adapter assembly into the detector fitting and tighten finger-tight. Use a wrench to tighten until snug.

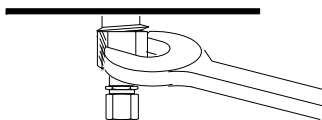

## To Install a Capillary Column with the Optional TCD Capillary Column Adapter

- 1 Gather the following:
  - Ferrule (See “Consumables and Parts for the TCD” on page 232.)
  - Column cutter
  - Column nut
  - 1/4-in. and 7/16-in. wrenches
  - Lint-free gloves
- 2 Load the [GC maintenance method](#) and wait for the GC to become ready.

**WARNING**

**Be careful! The detector may be hot enough to cause burns. If the detector is hot, wear heat-resistant gloves to protect your hands.**

---

**WARNING**

**Wear safety glasses to protect your eyes from flying particles while handling, cutting, or installing glass or fused silica capillary columns. Use care in handling these columns to prevent puncture wounds.**

---

**CAUTION**

**Wear clean, lint-free gloves to prevent contamination of parts with dirt and skin oils.**

---

- 3 Place a capillary column nut and ferrule on the column.

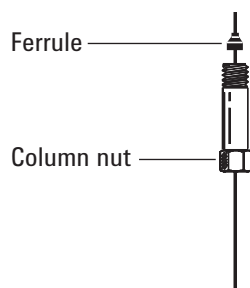

- 4 Score the column using a glass scribing tool. The score must be square to ensure a clean break.

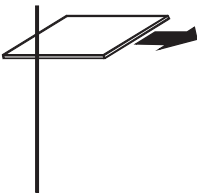

- 5 Break off the column end by supporting it against the column cutter opposite the scribe. Inspect the end with a magnifying loupe to make certain there are no burrs or jagged edges.

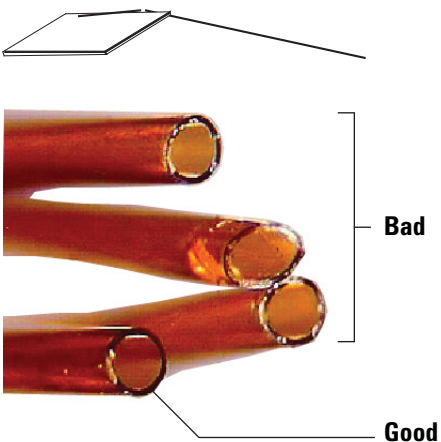

- 6 Wipe the column walls with a tissue dampened with isopropanol to remove fingerprints and dust.
- 7 Gently insert the column into the detector until it bottoms. Do not attempt to force it further.

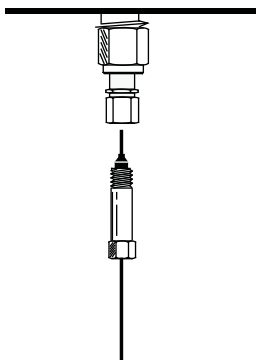

- 8 Slide the column nut and ferrule up the column to the adapter and tighten the nut finger tight.

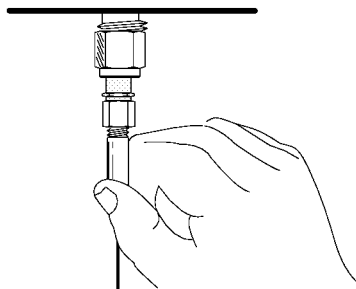

- 9 Pull the column out 1 mm. Use a wrench to tighten the nut an additional 1/4-turn. The column should not move.

## To Bakeout Contaminants from the TCD

The bakeout can be performed with the column installed or the detector capped.

**CAUTION**

If the column is not installed, you must turn off the TCD filament and cap the detector column fitting to prevent irreparable damage to the filament caused by oxygen entering the detector.

---

- 1 If the column is not installed, cap the detector.

**WARNING**

**Be careful! The detector may be hot enough to cause burns. If the detector is hot, wear heat-resistant gloves to protect your hands.**

---

- 2 Turn off the TCD filament.
- 3 If the column is attached to the inlet, maintain inert carrier gas flow through the column.

**WARNING**

**If using hydrogen as a carrier gas, turn off the hydrogen supply and cap the end of the column to prevent an oven explosion.**

---

- 4 Set the reference gas flow rate between 20 and 30 mL/min.
- 5 Set the detector temperature to 375 °C.
- 6 Hold at 375 °C for several hours.
- 7 If the column is uninstalled, install it. (See [“To Install a Capillary Column in the TCD”](#) on page 234.)
- 8 Load the analytical method.

**WARNING**

**Be careful! The oven or detector fittings may be hot enough to cause burns.**

---

- 9 Allow the oven, inlet, and detector to equilibrate at operating temperature, then re-tighten the fittings.



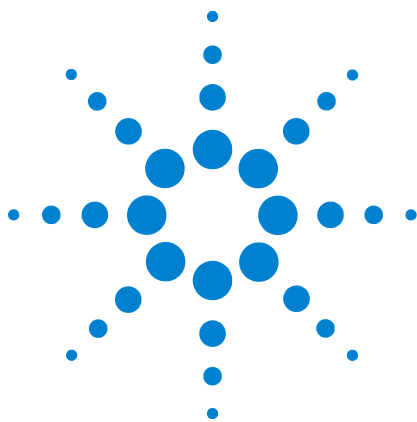

## 13 Maintaining the uECD

- Important Safety Information About the uECD [242](#)
- Consumables and Parts for the uECD [244](#)
- Exploded Parts View of the uECD [246](#)
- To Replace the uECD Fused Silica Indented Mixing Liner and Install the Makeup Gas Adapter [247](#)
- To Install a Capillary Column in the uECD [251](#)
- To Install the Insulating Cup for the uECD [254](#)
- To Bakeout the uECD [256](#)

This section describes the routine maintenance tasks for the micro-Electron Capture Detector (uECD). For important regulatory and safety information for this detector, refer to the general information booklet and CD provided with the detector.



## Important Safety Information About the uECD

The uECD contains a cell plated with  $^{63}\text{Ni}$ , a radioactive isotope. The beta particles released at the energy level in the detector have little penetrating power—the surface layer of the skin or a few sheets of paper will stop most of them—but they may be hazardous if the isotope is ingested or inhaled. For this reason, handle the cell with care. Cap the detector inlet and outlet fittings when the detector is not in use. Never introduce corrosive chemicals into the detector. Vent detector exhaust outside the laboratory environment.

Refer to the safety documentation provided with the detector for important details about safety, maintenance, and compliance with local government regulation.

**WARNING**

**Materials that may react with the  $^{63}\text{Ni}$  source, either to form volatile products or to cause physical degradation of the plated film, must be avoided. These materials include oxidizing compounds, acids, wet halogens, wet nitric acid, ammonium hydroxide, hydrogen sulfide, PCBs, and carbon monoxide. This list is not exhaustive but indicates the kinds of compounds that may cause damage to  $^{63}\text{Ni}$  detectors.**

---

**WARNING**

**In the extremely unlikely event that both the oven and the detector-heated zone should go into thermal runaway (maximum, uncontrolled heating in excess of 400 °C) at the same time and the detector remains exposed to this condition for more than 12 hours, take the following steps:**

- 1 After turning off the main power and allowing the instrument to cool, cap the detector inlet and exhaust vent openings. Wear disposable plastic gloves and observe normal laboratory safety precautions.**
- 2 Return the cell for disposal, following directions included with the License Verification Form (part number 19233-90750).**
- 3 Include a letter stating the condition of abuse.**

**It is unlikely, even in this very unusual situation, that radioactive material will escape the cell. However, permanent damage to the  $^{63}\text{Ni}$  plating within the cell is possible; therefore, the cell must be returned for exchange.**

---

**WARNING**

**Do not use solvents to clean the uECD.**

---

**WARNING**

**You may not open the uECD cell unless authorized to do so by your local nuclear regulatory agency. Do not disturb the four socket-head bolts. These hold the cell halves together. United States customers removing or disturbing them is a violation of the terms of the exemption and could create a safety hazard.**

---

When handling uECDs:

- Never eat, drink, or smoke.
- Always wear safety glasses when working with or near open uECDs.
- Wear protective clothing such as laboratory jackets, safety glasses, and gloves, and follow good laboratory practices. Wash hands thoroughly with a mild nonabrasive cleaner after handling uECDs.
- Cap the inlet and outlet fittings when the uECD is not in use.
- Connect the uECD exhaust vent to a fume hood or vent it to the outside. See the latest revision of 10 CFR Part 20 (including Appendix B), or the applicable state regulation. For other countries, consult with the appropriate agency for equivalent requirements.

Agilent Technologies recommends a vent line internal diameter of 6 mm (1/4-inch) or greater. With a line of this diameter, the length is not critical.

## Consumables and Parts for the uECD

See the Agilent catalog for consumables and supplies for a more complete listing, or visit the Agilent Web site for the latest information ([www.agilent.com/chem/supplies](http://www.agilent.com/chem/supplies)).

**Table 37** uECD consumables and parts

Description	Part number/quantity
Fused silica indented mixing liner	G2397-20540
Makeup gas adapter	G3433-63000
ECD wipe test kit	18713-60050
Insulation	19234-60715 (1/pk)
Insulation cup assembly	19234-60700
Nut, 1/4-inch Swagelok adapter	5180-4105 (10/pk)
Ferrule, graphitized Vespel, 1/4-inch	5080-8774 (10/pk)
Capillary column blanking nut	5020-8294
1/4-inch Detector adapter, for 1/8-inch packed columns	19301-80530

**Table 38** Nuts, ferrules, and hardware for capillary columns

Column id (mm)	Description	Typical use	Part number/quantity
.530	Ferrule, Vespel/graphite, 0.8-mm id	0.45-mm and 0.53-mm capillary columns	5062-3512 (10/pk)
	Ferrule, graphite, 1.0-mm id	0.53-mm capillary columns	5080-8773 (10/pk)
	Ferrule, graphite, 0.8-mm id	0.53-mm capillary columns	500-2118 (10/pk)
	Column nut, finger-tight (for 0.53-mm columns)	Connect column to inlet or detector	5020-8293
.320	Ferrule, Vespel/graphite, 0.5-mm id	0.32-mm capillary columns	5062-3514 (10/pk)
	Ferrule, graphite, 0.5-mm id	0.1-mm, 0.2-mm, 0.25-mm, and 0.32-mm capillary columns	5080-8853 (10/pk)
	Column nut, finger-tight (for .100- to .320-mm columns)	Connect column to inlet or detector	5020-8292

**Table 38** Nuts, ferrules, and hardware for capillary columns (continued)

Column id (mm)	Description	Typical use	Part number/quantity
.250	Ferrule, Vespel/graphite, 0.4-mm id	0.1-mm, 0.2-mm, and 0.25-mm capillary columns	5181-3323 (10/pk)
	Ferrule, graphite, 0.5-mm id	0.1-mm, 0.2-mm, 0.25-mm, and 0.32-mm capillary columns	5080-8853 (10/pk)
	Column nut, finger-tight (for .100- to .320-mm columns)	Connect column to inlet or detector	5020-8292
.100 and .200	Ferrule, Vespel/graphite, 0.37-mm id	0.1-mm and 0.2-mm capillary columns	5062-3516 (10/pk)
	Ferrule, Vespel/graphite, 0.4-mm id	0.1-mm, 0.2-mm, and 0.25-mm capillary columns	5181-3323 (10/pk)
	Ferrule, graphite, 0.5-mm id	0.1-mm, 0.2-mm, 0.25-mm, and 0.32-mm capillary columns	5080-8853 (10/pk)
	Ferrule, graphite, 0.4-mm id		500-2114 (10/pk)
	Column nut, finger-tight (for .100- to .320-mm columns)	Connect column to inlet or detector	5020-8292
All	Ferrule, no-hole	Testing	5181-3308 (10/pk)
	Capillary column blanking nut	Testing—use with any ferrule	5020-8294
	Column nut, universal	Connect column to inlet or detector	5181-8830 (2/pk)
	Column cutter, ceramic wafer	Cutting capillary columns	5181-8836 (4/pk)
	Pencil, diamond tipped	Cutting capillary columns	420-1000
	Ferrule tool kit	Ferrule installation	440-1000

## Exploded Parts View of the uECD

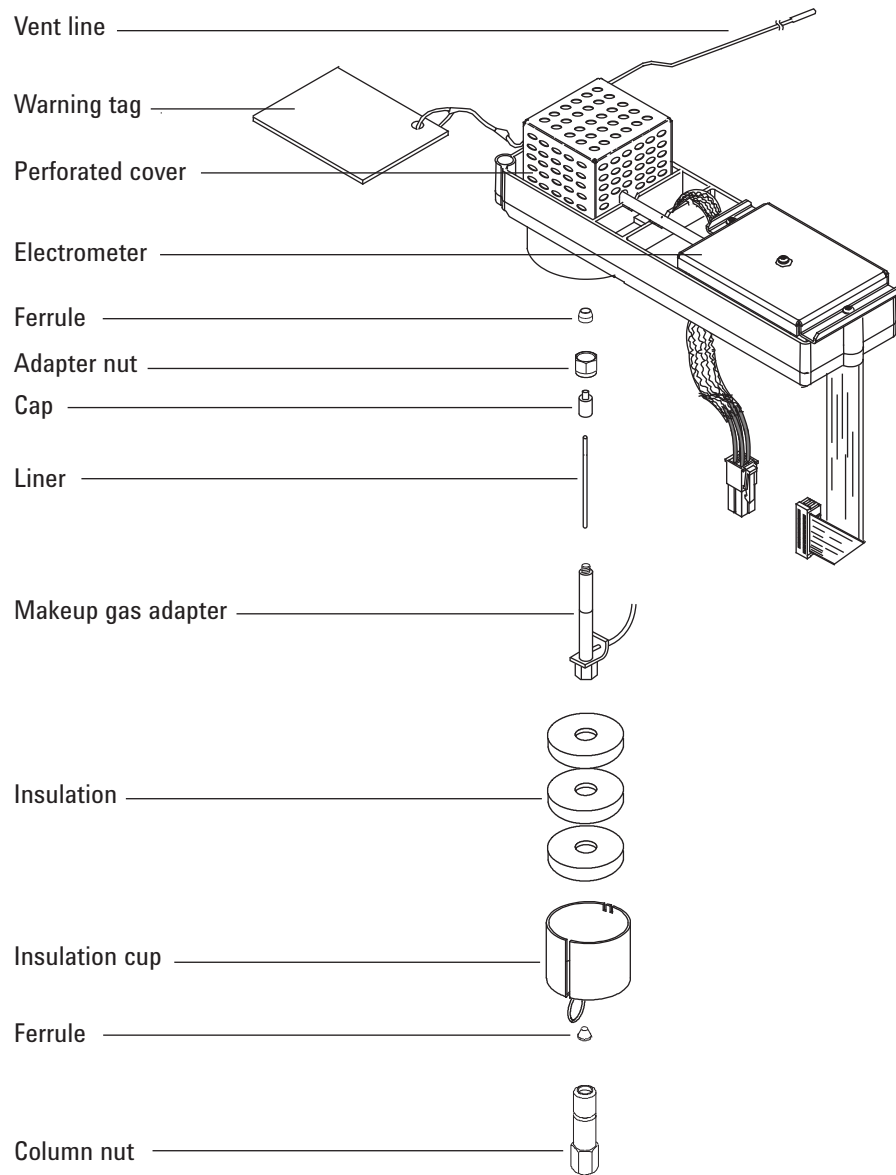

## To Replace the uECD Fused Silica Indented Mixing Liner and Install the Makeup Gas Adapter

- 1 Gather the following:
  - Fused silica indented mixing liner (See “Consumables and Parts for the uECD” on page 244.)
  - 1/4-inch Swagelok nut
  - 1/4-inch Vespel/graphite ferrule
  - 9/16-inch wrench
  - Methanol
  - Lint-free gloves
- 2 Load the [GC maintenance method](#) and wait for the GC to become ready.

**WARNING**

**Be careful! The oven and/or detector may be hot enough to cause burns. If the detector is hot, wear gloves to protect your hands.**

---

**WARNING**

**Wear safety glasses to protect your eyes from flying particles while handling, cutting, or installing glass or fused silica capillary columns. Use care in handling these columns to prevent puncture wounds.**

---

- 3 Remove the insulating cup from the detector base.
- 4 Remove the column from the makeup gas adapter.

**CAUTION**

To prevent damage avoid flexing/bending the tubing on the makeup gas adapter.

---

- 5 Remove the makeup gas adapter.
  - a Loosen the adapter nut with a wrench and slide out the makeup gas adapter from the uECD. Remove the ferrule.

The makeup gas adapter will remain attached to the supply tubing and hang suspended in the oven.

- b Adjust the adapter's position so that maintenance can be performed on the adapter easily and without obstruction.

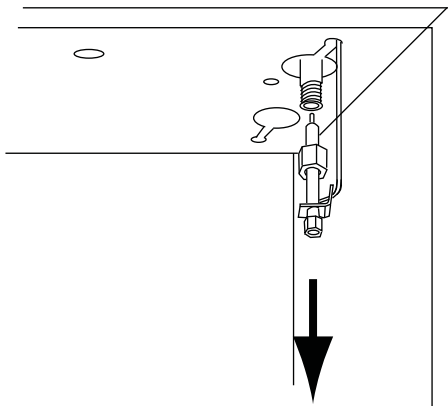

- 6 Unscrew and remove the adapter cap.

**CAUTION**

Wear clean, lint-free gloves to prevent contamination of parts with dirt and skin oils.

- 7 Remove the fused silica indented mixing liner and inspect. Replace it if it is broken or contaminated with sample or graphite.
- 8 Ultrasonically clean the adapter cap in methanol. Clean the outer surfaces of the makeup gas adapter with methanol.
- 9 Install the fused silica indented mixing liner into the makeup gas adapter, then install the cap. The indentation on the fused silica indented mixing liner must be at the cap end of the adapter.



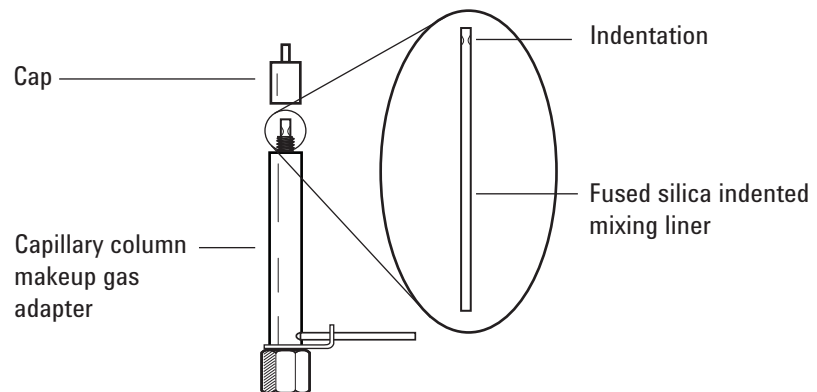

- 10** Place a new 1/4-inch Swagelok nut and ferrule onto the makeup gas adapter.

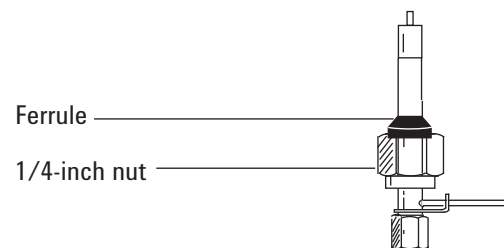

- 11** Slowly install the adapter straight into the detector fitting. Jiggle the adapter, if necessary, to make sure it is seated all the way into the detector fitting. Be careful not to break the column end.

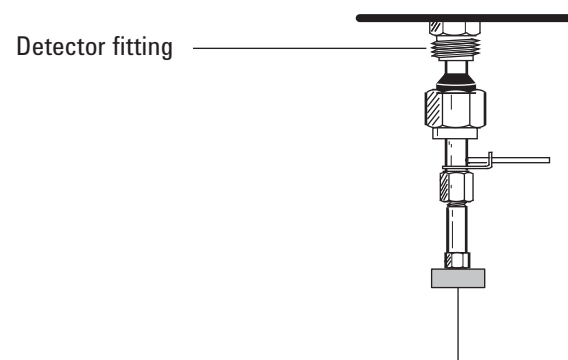

- 12** Tighten the nut finger-tight and then use a 9/16-inch wrench to tighten until snug.

If the adapter is properly installed, the distance between the 1/4-inch nut and the bottom of the adapter will be  $19 \pm 1$  mm. If the distance is 22 to 23 mm, install the adapter into the detector fitting.

## 13 Maintaining the uECD

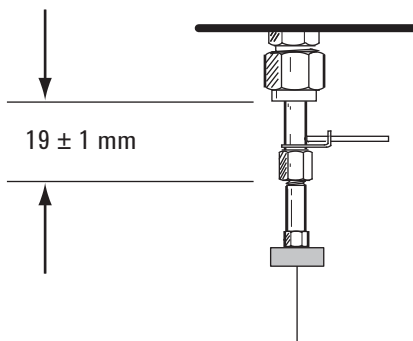

- 13 Attach the column. (See [“To Install a Capillary Column in the uECD”](#) on page 251.)
- 14 Reset the EMF counter. See [To Reset an EMF Counter](#) in the *Operation Manual*.

## To Install a Capillary Column in the uECD

- 1 Gather the following:
  - Ferrule (See “Consumables and Parts for the uECD” on page 244.)
  - Column nut
  - Septum
  - Column
  - 1/4-inch, 5/16-inch, and 9/16-inch wrenches
  - Column cutter
  - Lint-free gloves
- 2 Load the [GC maintenance method](#) and wait for the GC to become ready.

**WARNING**

**Be careful! The oven and/or detector may be hot enough to cause burns. If the detector is hot, wear gloves to protect your hands.**

---

**WARNING**

**Wear safety glasses to protect your eyes from flying particles while handling, cutting, or installing glass or fused silica capillary columns. Use care in handling these columns to prevent puncture wounds.**

---

- 3 Load the [inlet maintenance method](#) and wait for the GC to become ready.

**CAUTION**

Wear clean, lint-free gloves to prevent contamination of parts with dirt and skin oils.

---

- 4 Place a septum (if the column id is  $\leq 0.2$  mm), capillary column nut, and ferrule on the column.

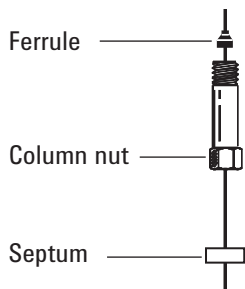

- 5 Score the column using a glass scribing tool. The score must be square to ensure a clean break.

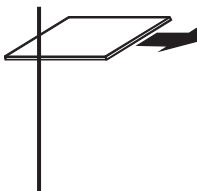

- 6 Break off the column end by supporting it against the column cutter opposite the scribe. Inspect the end with a magnifying loupe to make certain there are no burrs or jagged edges.

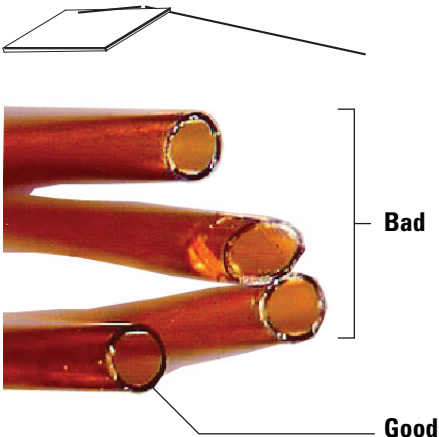

- 7 Wipe the column walls with a tissue dampened with isopropanol to remove fingerprints and dust.
- 8 Install the column.

**If the column id is 200 um or more**, push the column into the adapter until it stops at the indentation. Pull it back 1 to 2 mm and tighten the column nut with one 5/16-inch wrench on the adapter and another 1/4-inch wrench on the column nut.

If the id is less the 200  $\mu\text{m}$ , mark the column with a septum  $70 \pm 1$  mm from the end. Insert column and nut into the adapter with the septum at the rear of the column nut, and tighten the column nut with one  $5/16$ -inch wrench on the adapter and another  $1/4$ -inch wrench on the column nut.

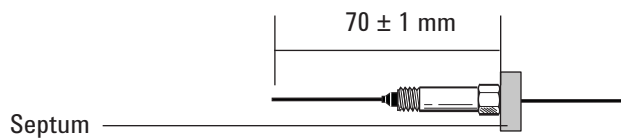

- 9 After heating the detector, retighten the  $9/16$ -inch makeup adapter nut and  $1/4$ -inch column nut.

## To Install the Insulating Cup for the uECD

- 1 Gather the following:
  - Nut warmer insulation (See “Consumables and Parts for the uECD” on page 244.)
  - Insulation cup assembly
- 2 Load the [GC maintenance method](#) and wait for the GC to become ready.

**WARNING**

**Be careful! The oven and/or detector may be hot enough to cause burns. If the detector is hot, wear gloves to protect your hands.**

---

- 3 Install the insulation in the cup. Line up the slots in the insulation with the slot in the cup.



- 4 Push the wire spring lever to the right to uncover the hole.

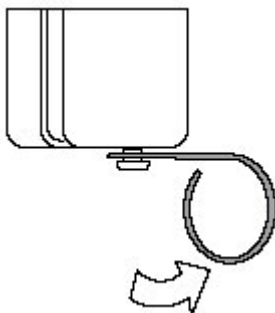

- 5 With a capillary column installed to prevent insulation contamination of the detector, slide the column into the slot on the insulation cup and place the cup over the makeup gas adapter.

- 6 Slide the cup up so that the cup touches the top of the oven and you can see the groove in the makeup gas adapter.
- 7 Release the spring into the groove of the makeup gas adapter.

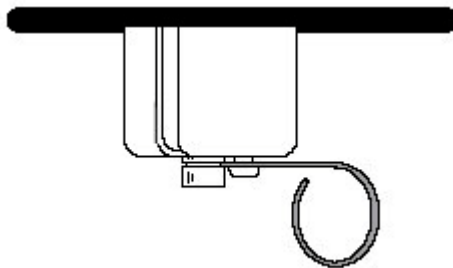

## To Bakeout the uECD

**WARNING**

Detector disassembly and/or cleaning procedures other than thermal should be performed only by personnel trained and licensed appropriately to handle radioactive materials. Trace amounts of radioactive  $^{63}\text{Ni}$  may be removed during other procedures, causing possible hazardous exposure to b- and x-radiation.

---

**CAUTION**

To prevent possible hazardous contamination of the area with radioactive material, the detector exhaust vent always must be connected to a fume hood or otherwise vented in compliance with the latest revision of 10 CFR Part 20, or with state regulations with which the Nuclear Regulatory Commission has entered into an agreement (USA only). For other countries, consult with the appropriate agency for equivalent requirements.

---

- 1 Gather the following:
  - Column nut and no-hole ferrule (See [“Consumables and Parts for the uECD”](#) on page 244.)
  - Blanking nut with any column ferrule
- 2 With the detector and oven at normal operating temperatures, show the detector output. Press **[Front Det]** or **[Back Det]**. Note the value of **Output** for later comparison.
- 3 Load the [GC maintenance method](#) and wait for the GC to become ready.

**WARNING**

**Be careful! The oven and/or detector may be hot enough to cause burns. If the detector is hot, wear gloves to protect your hands.**

---

**WARNING**

**Wear safety glasses to protect your eyes from flying particles while handling, cutting, or installing glass or fused silica capillary columns. Use care in handling these columns to prevent puncture wounds.**

---

- 4 If the column maximum temperature is  $< 250\text{ }^{\circ}\text{C}$ , remove the column from the detector.



- 5 If the column is uninstalled, plug the detector connection with the column nut and no-hole ferrule.

Maintain inert carrier gas flow through the column, or remove the column from the GC.

- 6 Set the uECD temperature to 350 to 375 °C, the makeup gas flow to 60 mL/min, and the oven temperature to 250 °C. If the column is uninstalled, leave the oven off to protect the column.
- 7 If the column is installed in the uECD, set the oven temperature to 250 °C. If the column is uninstalled, leave the oven off to protect the column.
- 8 Allow thermal cleaning to continue for several hours and then cool the system to normal operating temperatures. The figure below shows detector output during a typical cleaning cycle.

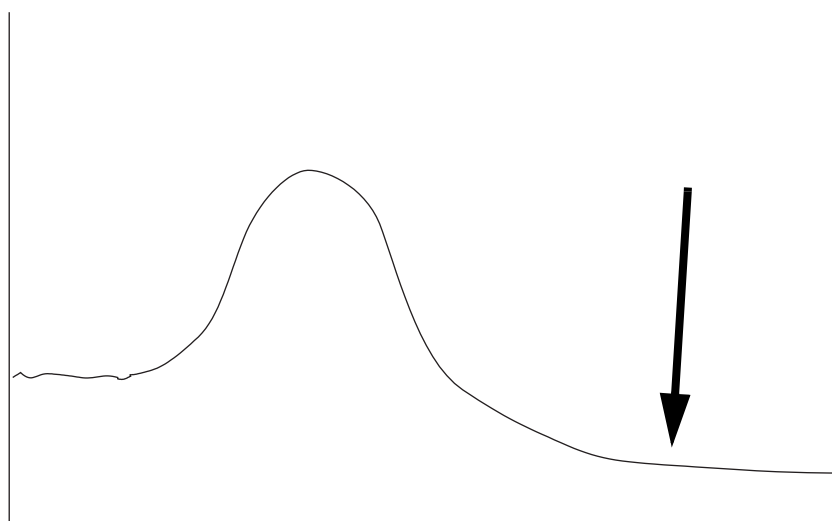

- 9 Check the uECD output value on the control table. It should be lower than the first reading. If it is not, contact your Agilent service representative.
- 10 Reinstall the column.
- 11 Restore the analytical method.

## 13 Maintaining the uECD



## 14 Maintaining the NPD

- Consumables and Parts for the NPD [260](#)
- Exploded Parts View of the NPD [263](#)
- Selecting an NPD Jet [264](#)
- To Attach a Capillary Column Adapter on an Adaptable NPD [266](#)
- To Install a Capillary Column in the NPD [268](#)
- To Replace the NPD Bead Assembly [272](#)
- To Maintain the NPD Collector, Ceramic Insulators, and Jet [279](#)
- To Check the NPD Leakage Current [285](#)
- To Bakeout the NPD [286](#)



## Consumables and Parts for the NPD

See the Agilent catalog for consumables and supplies for a more complete listing, or visit the Agilent Web site for the latest information ([www.agilent.com/chem/supplies](http://www.agilent.com/chem/supplies)).

Before selecting a jet, see “Selecting an NPD Jet” on page 264.

**Table 39** NPD parts

Description	Part number/quantity
Collector	G1534-20530
Screw, M3 × 0.5 × 8 mm	0515-0655
NPD white ceramic bead assembly	G1534-60570
NPD black ceramic bead assembly	5183-2007
NPD Blos bead assembly	G3434-60806
Screw, M4 × 10 mm	0515-2495
J-clamp	1400-0015
NPD ceramic insulator kit <ul style="list-style-type: none"> <li>• Metal C-rings, top and bottom</li> <li>• Ceramic insulators, upper and lower</li> </ul>	5182-9722
Insulation cup	19234-60720
NPD chemical sample kit solution of 0.65 ppm azobenzene, 1000 ppm octadecane, 1 ppm malathion in isooctane, 3 ampoules	18789-60060
NPD lid standoff	G1534-20590
<b>Column adapters, for adaptable NPD only</b>	
FID/NPD capillary column adapter	19244-80610
1/8-inch packed column adapter	19231-80520
1/4-inch packed column adapter	19231-80530
1/4-inch packed glass column adapter	G1532-20710
1/4-inch column nut	5180-4105 10/pk
1/4-inch Vespel/graphite ferrule	5080-8774 10/pk

**Table 40** Jets for capillary optimized fittings

Jet type	Part number	Jet tip id	Length
Capillary with extended jet (recommended)	G1534-80580	0.29 mm (0.011 inch)	51.5 mm
Capillary	G1531-80560	0.29 mm (0.011 inch)	43 mm
High-temperature	G1531-80620	0.47 mm (0.018 inch)	43 mm

**Table 41** Jets for adaptable fittings

Jet type	Part number	Jet tip id	Length
Capillary with extended jet (recommended)	G1534-80590	0.29 mm (0.11 inch)	70.5 mm
Capillary	19244-80560	0.29 mm (0.011 inch)	61.5 mm
Capillary, high-temperature	19244-80620	0.47 mm (0.018 inch)	61.5 mm
Packed	18710-20119	0.46 mm (0.018 inch)	63.6 mm

**Table 42** Nuts, ferrules, and hardware for capillary columns

Column id (mm)	Description	Typical use	Part number/quantity
.530	Ferrule, Vespel/graphite, 0.8-mm id	0.45-mm and 0.53-mm capillary columns	5062-3512 (10/pk)
	Ferrule, graphite, 1.0-mm id	0.53-mm capillary columns	5080-8773 (10/pk)
	Ferrule, graphite, 0.8-mm id	0.53-mm capillary columns	500-2118 (10/pk)
	Column nut, finger-tight (for 0.53-mm columns)	Connect column to inlet or detector	5020-8293
.320	Ferrule, Vespel/graphite, 0.5-mm id	0.32-mm capillary columns	5062-3514 (10/pk)
	Ferrule, graphite, 0.5-mm id	0.1-mm, 0.2-mm, 0.25-mm, and 0.32-mm capillary columns	5080-8853 (10/pk)
	Column nut, finger-tight (for .100- to .320-mm columns)	Connect column to inlet or detector	5020-8292

**Table 42** Nuts, ferrules, and hardware for capillary columns (continued)

Column id (mm)	Description	Typical use	Part number/quantity
.250	Ferrule, Vespel/graphite, 0.4-mm id	0.1-mm, 0.2-mm, and 0.25-mm capillary columns	5181-3323 (10/pk)
	Ferrule, graphite, 0.5-mm id	0.1-mm, 0.2-mm, 0.25-mm, and 0.32-mm capillary columns	5080-8853 (10/pk)
	Column nut, finger-tight (for .100- to .320-mm columns)	Connect column to inlet or detector	5020-8292
.100 and .200	Ferrule, Vespel/graphite, 0.37-mm id	0.1-mm and 0.2-mm capillary columns	5062-3516 (10/pk)
	Ferrule, Vespel/graphite, 0.4-mm id	0.1-mm, 0.2-mm, and 0.25-mm capillary columns	5181-3323 (10/pk)
	Ferrule, graphite, 0.5-mm id	0.1-mm, 0.2-mm, 0.25-mm, and 0.32-mm capillary columns	5080-8853 (10/pk)
	Ferrule, graphite, 0.4-mm id		500-2114 (10/pk)
	Column nut, finger-tight (for .100- to .320-mm columns)	Connect column to inlet or detector	5020-8292
All	Ferrule, no-hole	Testing	5181-3308 (10/pk)
	Capillary column blanking nut	Testing—use with any ferrule	5020-8294
	Column nut, universal	Connect column to inlet or detector	5181-8830 (2/pk)
	Column cutter, ceramic wafer	Cutting capillary columns	5181-8836 (4/pk)
	Pencil, diamond tipped	Cutting capillary columns	420-1000
	Ferrule tool kit	Ferrule installation	440-1000

## Exploded Parts View of the NPD

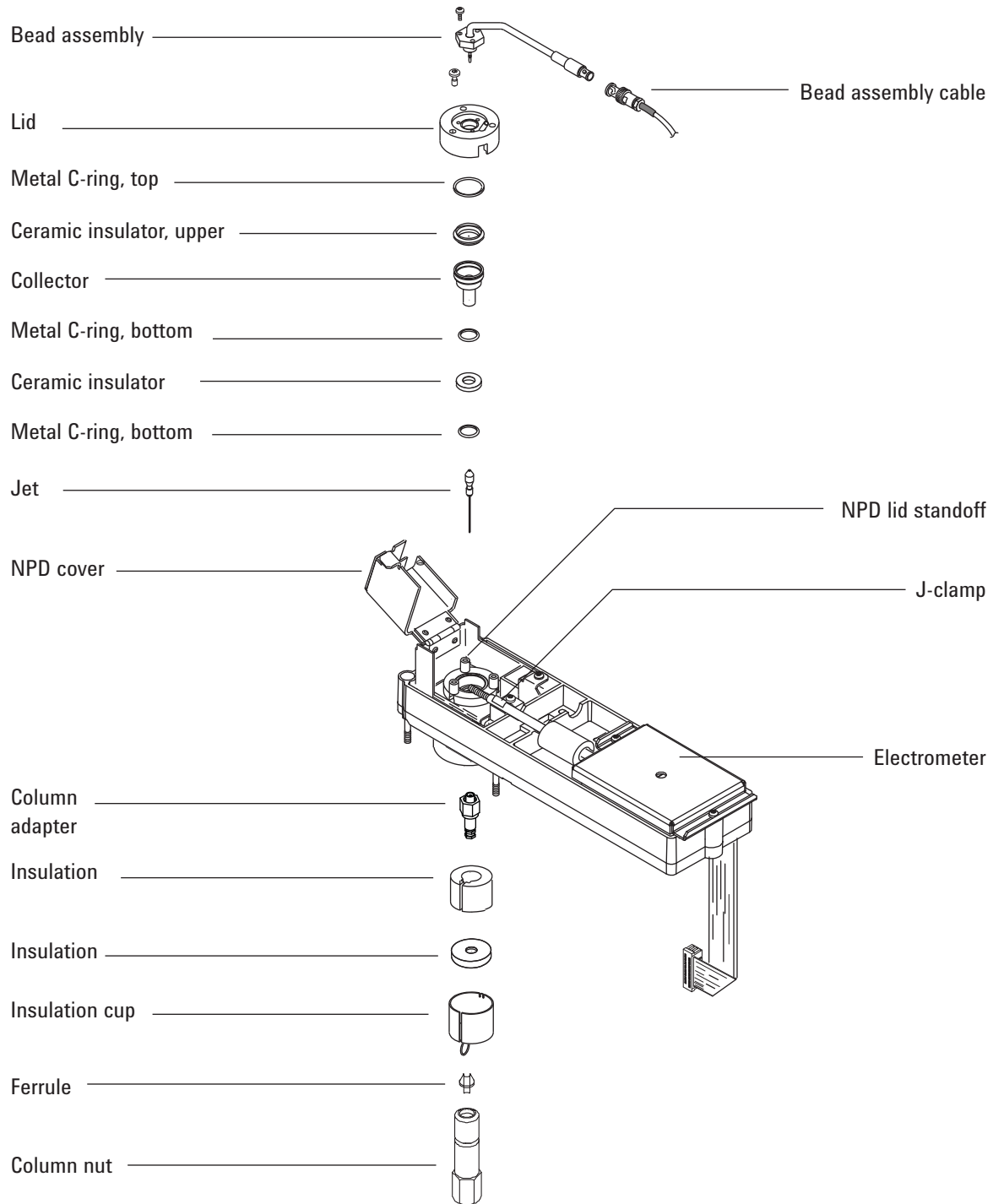

## Selecting an NPD Jet

Open the oven door and locate the column connection fitting at the base of the detector. It will look like either a capillary optimized fitting or an adaptable fitting.

Capillary optimized fitting



Adaptable fitting



- If you have an application that tends to clog the jet, select a jet with a wider tip id.
- When using packed columns in high column-bleed applications, the jet tends to clog with silicon dioxide.

For capillary optimized fittings, select one of the following from [Table 43](#).

**Table 43** Jets for capillary optimized fittings

Figure 3 ID	Jet type	Part number	Jet tip id	Length
1	Capillary with extended jet (recommended)	G1534-80580	0.29 mm (0.011 inch)	51.5 mm
2	Capillary	G1531-80560	0.29 mm (0.011 inch)	43 mm
3	High-temperature	G1531-80620	0.47 mm (0.018 inch)	43 mm



**Figure 5** Capillary optimized NPD jets

For adaptable fittings, select one of the following from [Table 44](#).



**Table 44** Jets for adaptable fittings

Figure 4 ID	Jet type	Part number	Jet tip id	Length
1	Capillary with extended jet (recommended)	G1534-80590	0.29 mm (0.011 inch)	70.5 mm
2	Capillary	19244-80560	0.29 mm (0.011 inch)	61.5 mm
3	Capillary, high-temperature	19244-80620	0.47 mm (0.018 inch)	61.5 mm
4	Packed	18710-20119	0.46 mm (0.018 inch)	63.6 mm



**Figure 6** Adaptable NPD jets

## To Attach a Capillary Column Adapter on an Adaptable NPD

- 1 Gather the following materials:
  - Adapter (See “Consumables and Parts for the NPD” on page 260.)
  - 1/4-inch nut
  - 1/4-inch ferrule
  - Column cutter
  - 1/4-inch wrench
  - 9/16-inch open-end wrench
  - Lint-free gloves
- 2 Load the [GC maintenance method](#) and wait for the GC to become ready.

**WARNING**

**Be careful! The oven, inlet, and/or detector may be hot enough to cause burns. If the oven, inlet, or detector is hot, wear heat-resistant gloves to protect your hands.**

**WARNING**

**Wear safety glasses to protect your eyes from flying particles while handling, cutting, or installing glass or fused silica capillary columns. Use care in handling these columns to prevent puncture wounds.**

**CAUTION**

Wear clean, lint-free gloves to prevent contamination of parts with dirt and skin oils.

- 3 Assemble a brass nut and Vespel/graphite ferrule onto the adapter.

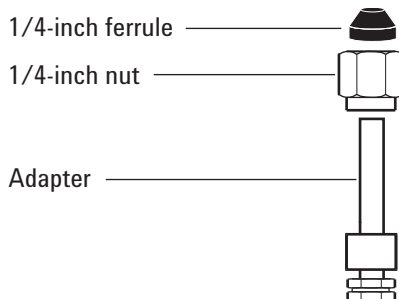

- 4 Insert the adapter straight into the detector base as far as possible.
- 5 Hold the adapter in this position and finger-tighten the nut.

Adaptable fitting



- 6 Tighten an additional 1/4 turn with a wrench.

## To Install a Capillary Column in the NPD

- 1 Gather the following materials:
  - Column
  - Ferrule(s) (See [“Consumables and Parts for the NPD”](#) on page 260.)
  - Column nut
  - Column cutter
  - 1/4-inch open-end wrench
  - Septum
  - Isopropanol
  - Lab tissue
  - Lint-free gloves
- 2 Load the [GC maintenance method](#) and wait for the GC to become ready.

**WARNING**

**Be careful! The oven, inlet, and/or detector may be hot enough to cause burns. If the oven, inlet, or detector is hot, wear heat-resistant gloves to protect your hands.**

---

**WARNING**

**Wear safety glasses to protect your eyes from flying particles while handling, cutting, or installing glass or fused silica capillary columns. Use care in handling these columns to prevent puncture wounds.**

---

If using the adaptable detector, verify that the adapter is installed. (See [“To Attach a Capillary Column Adapter on an Adaptable NPD”](#) on page 266.)



**CAUTION**

Wear clean, lint-free gloves to prevent contamination of parts with dirt and skin oils.

- Place a septum (if the column id is  $\leq 0.1$  mm), capillary column nut, and ferrule on the column.

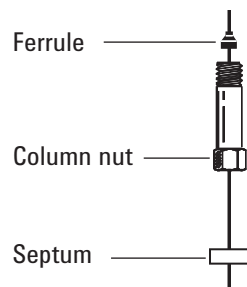

- Score the column using a glass scribing tool. The score must be square to ensure a clean break.

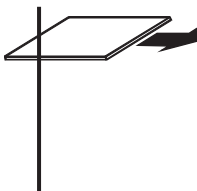

- Break off the column end by supporting it against the column cutter opposite the scribe. Inspect the end with a magnifying loupe to make certain there are no burrs or jagged edges.

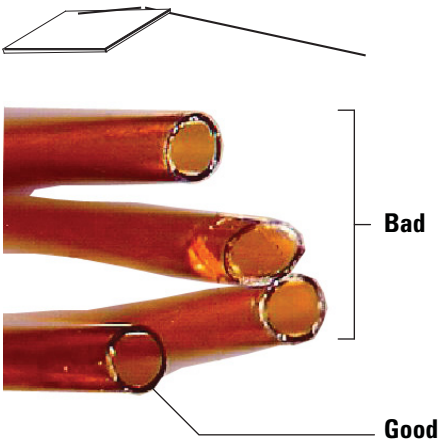

- Wipe the column walls with a tissue dampened with isopropanol to remove fingerprints and dust.
- Install the capillary column.

If the column id is greater than 0.1 mm:

- a Gently insert the column into the detector until it bottoms; do not attempt to force it further.
- b Finger-tighten the column nut, then withdraw the column about 1 mm. Tighten the nut an additional 1/4 turn with a wrench.

If the column id is 0.1 mm or less position the column so it extends above the ferrule by 48 mm (*capillary optimized fitting*) or 68 mm (*adaptable fitting*). Slide the septum up to hold the column nut and ferrule at this fixed position.

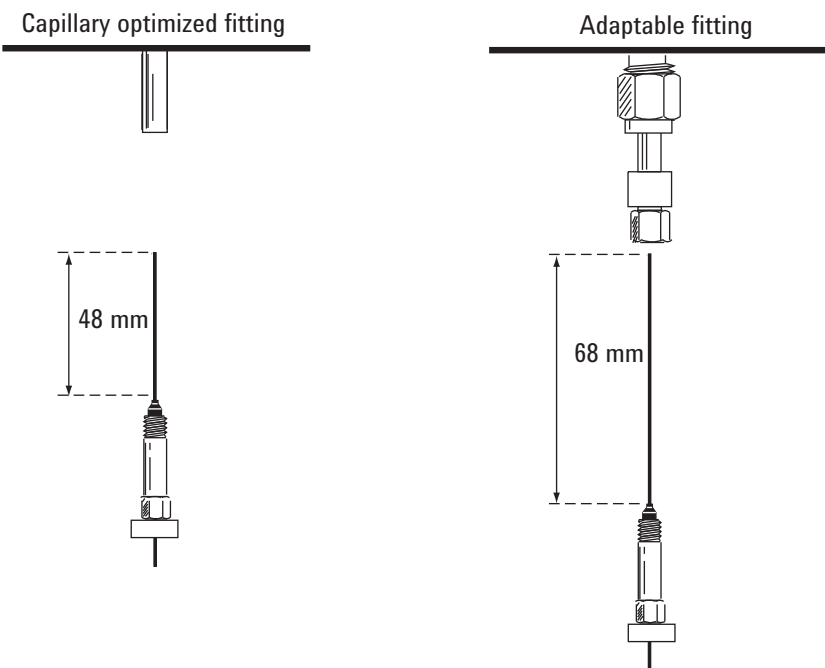

- c Insert the column into the detector. Slide the nut and ferrule up the column to the detector base. Finger-tighten the column nut until it grips the column.
- d Adjust the column (*not* the septum) position so that the septum is even with the bottom of the column nut. Tighten the nut an additional 1/4 turn with a wrench.

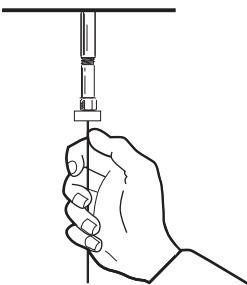

## To Replace the NPD Bead Assembly

- 1 Gather the following:
  - Replacement NPD bead assembly. (See [“Consumables and Parts for the NPD”](#) on page 260.)
  - Lint-free gloves
  - T-10 Torx screwdriver

**CAUTION**

The bead is delicate. Be careful not to break or crack the bead. When performing maintenance on the NPD, avoid touching the bead with your fingers, and prevent it from coming in contact with other surfaces.

---

- 2 Set the NPD bead voltage to **0.0**, then turn it off. (Setting the bead voltage to zero first makes sure that when you turn the bead back on, the voltage is safe. Otherwise, turning off the bead voltage will save a high setpoint that can damage a new bead.)

Agilent data system users: After setting the bead voltage to 0.0, save the data system method and shut down the instrument session. (Note that in some data system versions, you may need to use the GC keypad to set the voltage. To do this, the keypad must be unlocked and you must close the GC parameters screen of the data system. Upload the revised setting, then save the method and shut down the instrument session.)

- 3 Set **Adjust Offset** to **Off**.
- 4 Cool the detector to 60 °C or lower. Leave all gas flows on. To cool the detector faster, raise the GC detector cover and open the hinged NPD cover.
- 5 Remove the GC detector top cover.

**WARNING**

**Hazardous voltages are present when the electronics top cover is open.**

---

- 6 Remove the electronics cover. See [“To Remove the Electronics Cover”](#).





- 7 Put on lint-free gloves before touching any of the detector parts.

**WARNING**

**Be careful! The oven or detector fittings may be hot enough to cause burns.**

---

**CAUTION**

Wear clean, lint-free gloves to prevent contamination of parts with dirt and skin oils.

---

- 8 Twist the ring to disconnect the bead assembly cable. Push and twist the lock so that the button slides up in the groove, then pull the cable ends apart.

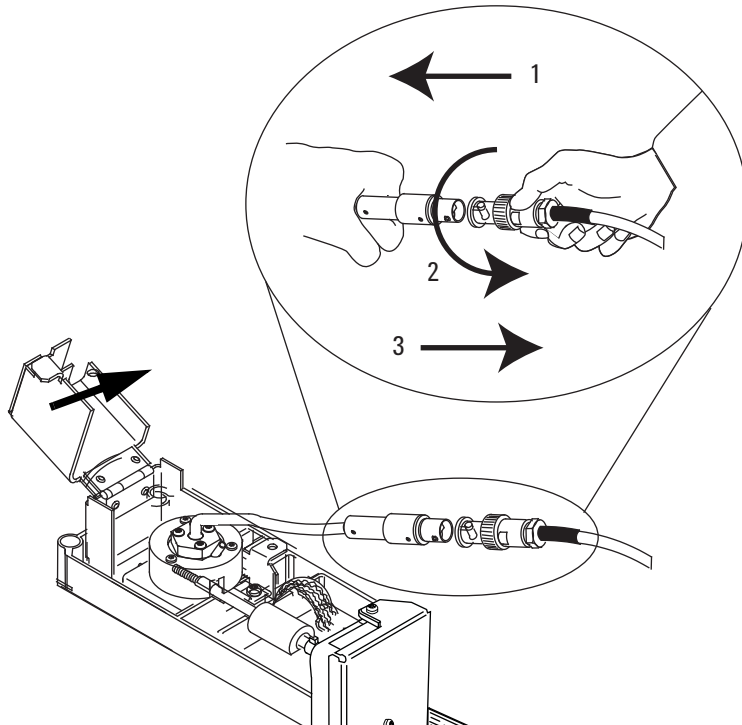
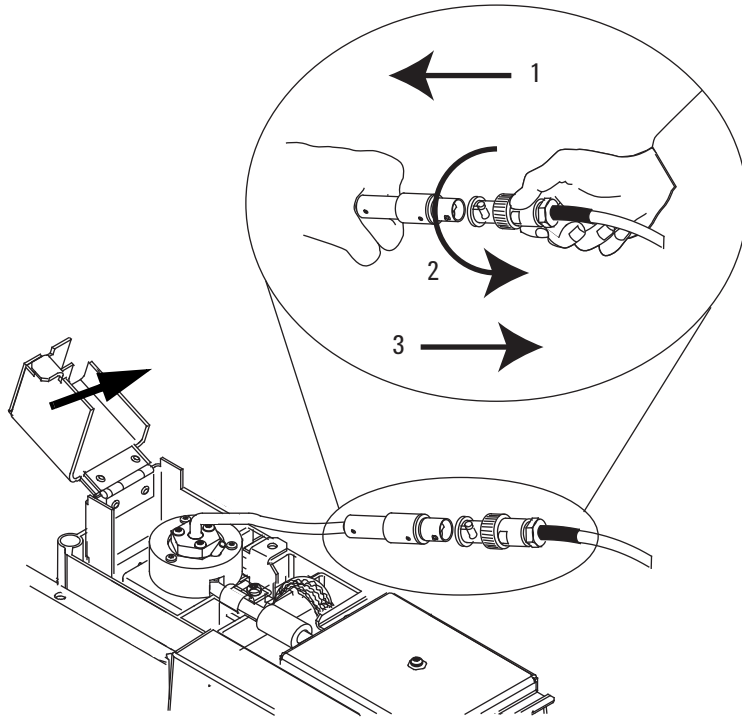

- 9 Remove the 3 T-10 Torx screws from the bead assembly.

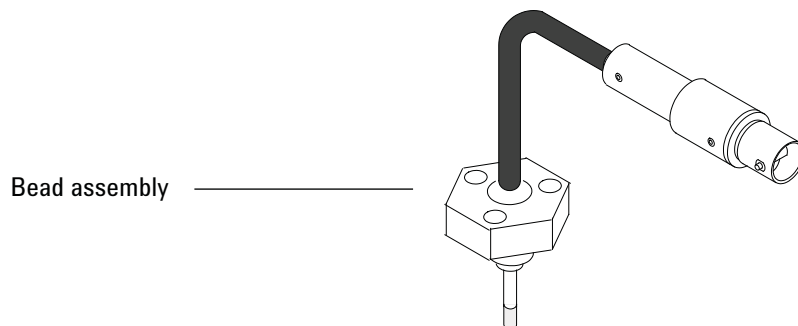

- 10 Gently lift up and remove the old bead assembly. Avoid bumping the bead on the sides of the collector.

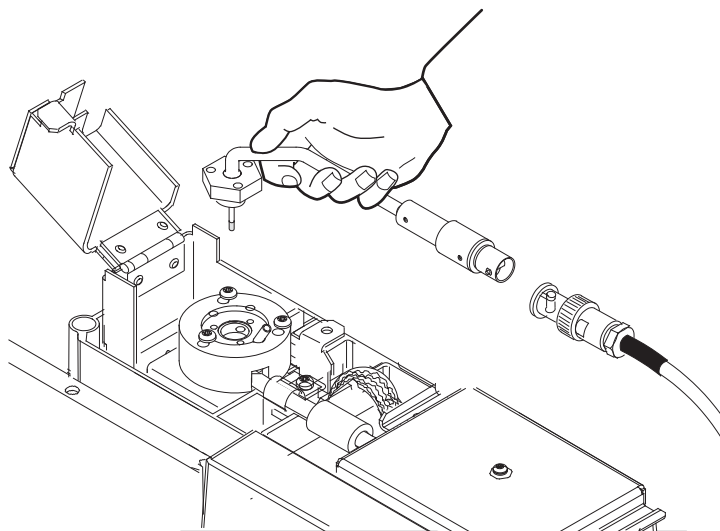

- 11 Remove the protective cap covering the new bead.
- 12 Mount the new bead assembly on the NPD lid. Be careful not to bump the bead on the sides of the lid or collector.
- 13 Replace the screws. Finger-tighten the first screw; tighten the remaining screws normally and then completely tighten the first screw. Do not overtighten the screws.

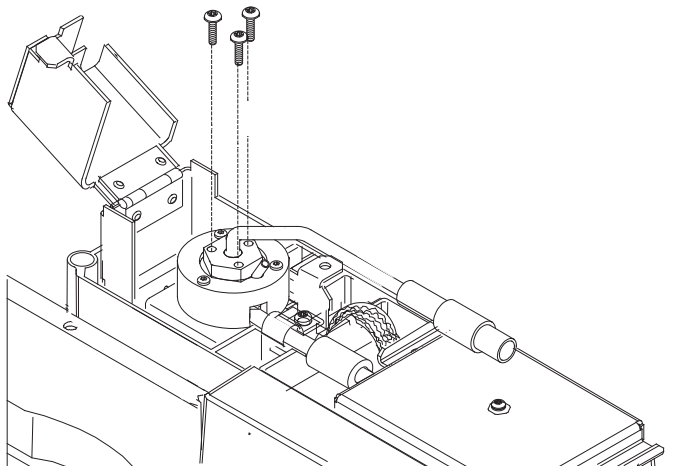

**14** Carefully bend the bead assembly cable 90 °.

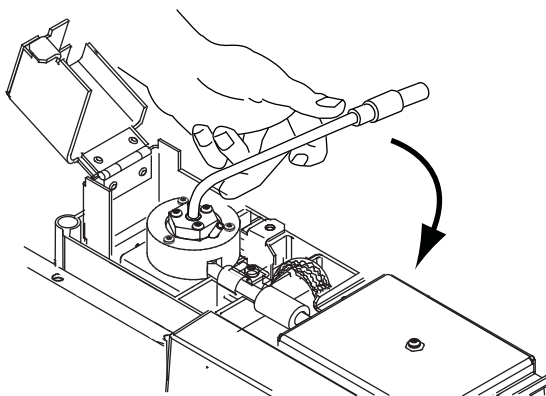

**15** Reconnect the bead assembly cable to the NPD cable and twist the ring to lock the connection.

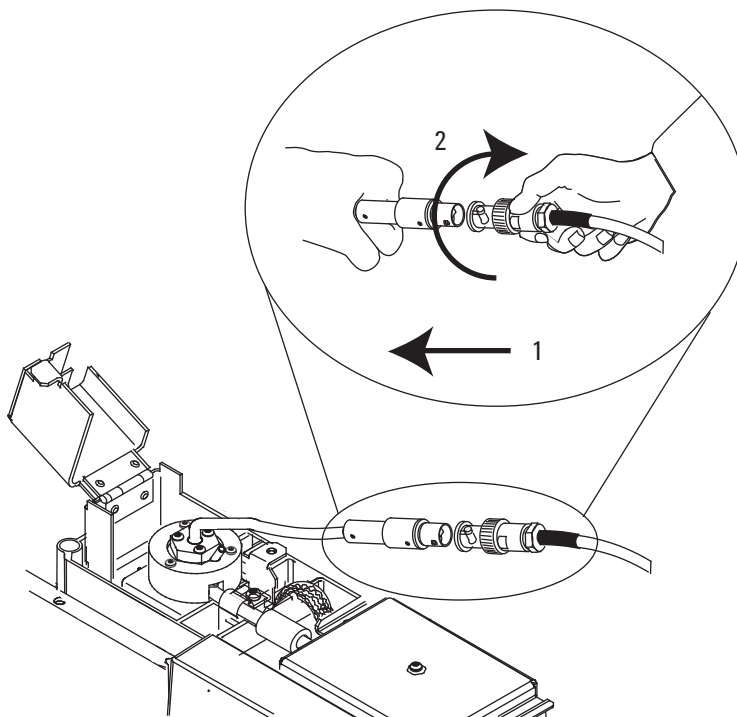

- 16 Close the NPD cover, install the GC detector top cover, and install the electronics top cover. All covers must be closed to get a stable NPD baseline.
- 17 Configure the new bead.
  - Set the bead type.
  - Review the **Maximum Bead Voltage** setting and adjust, if necessary.
  - Review the **Dry Bead** and **Auto Adjust Bead** settings.
- 18 Restore normal NPD operating gas flows.
- 19 With all gases on, heat the detector to 150 °C and hold for about 15 minutes, then increase the temperature to 250 °C and hold for 15 minutes.
- 20 Increase the temperature to operating value (310 to 320 °C recommended). Allow 15 minutes for equilibration.
- 21 Check the NPD leakage current. (See [“To Check the NPD Leakage Current”](#) on page 285.) If > 2.0 pA, verify bead installation or see the [Troubleshooting manual](#).
- 22 If using an Agilent data system, connect to the instrument.
- 23 Restore the analytical method. Confirm the detector hydrogen, air, makeup gas flow rates.

- 24 Start the **Adjust offset** process. Enter the desired offset in the **Target offset** field. The default offset is 20 pA for Blos beads, and 30 pA for white or black beads. For white and black beads, an offset of 25 to 30 pA is sufficient for most applications. The bead life may be shortened at a higher offset.
- 25 Reset the bead counter. See [To Reset an EMF Counter](#) in the *Operation Manual*.

## To Maintain the NPD Collector, Ceramic Insulators, and Jet

When replacing the jet, always install a new collector, ceramic insulators, and metal C-rings.

When replacing the collector, Agilent recommends replacing the ceramic insulators and metal C-rings.

1 Gather the following:

- NPD ceramic insulator kit (see [“Consumables and Parts for the NPD”](#) on page 260.)
- Collector
- Cap for the bead
- T-10 and T-20 Torx screwdrivers
- Tweezers
- Cotton swab
- Solvent
- Methanol
- Jet (see [“Selecting an NPD Jet”](#) on page 264)
- Lint-free gloves
- Compressed, filtered dry air or nitrogen

### CAUTION

The bead is delicate. Be careful not to break or crack the bead. When performing maintenance on the NPD, avoid touching the bead with your fingers, and prevent it from coming in contact with other surfaces.

2 Set the bead voltage to **0.0** and **Adjust Offset** to **Off**.

3 Check and note the NPD leakage current for reference. (See [“To Check the NPD Leakage Current”](#) on page 285.)

4 Load the [GC maintenance method](#) and wait for the GC to become ready.

### WARNING

**Be careful! The oven or detector fittings may be hot enough to cause burns.**

5 Remove the bead. (See [“To Replace the NPD Bead Assembly”](#) on page 272.)

**CAUTION**

This step exposes the interconnect spring. Be careful not to touch or disfigure the spring while working on the FID. Any dirt or bending will reduce the sensitivity of your detector.

**CAUTION**

Wear clean, lint-free gloves to prevent contamination of parts with dirt and skin oils.

- 6 Remove the screws that secure the lid, and remove it. The top metal C-ring and upper ceramic insulator may be attached to the lid.

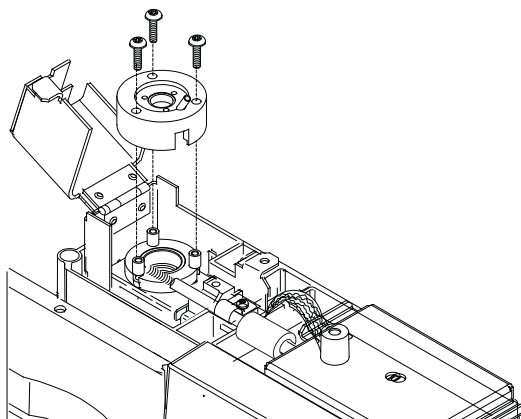

- 7 Remove the screws that secure the electrometer and the interconnect.

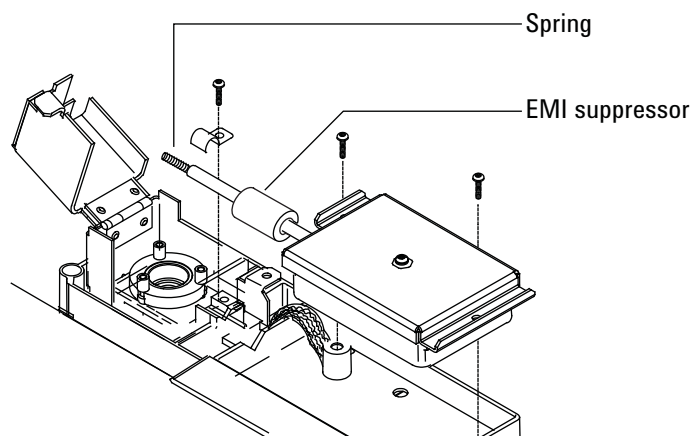

- 8 Pull the electrometer away from the detector to free the interconnect. Turn the electrometer to the right to obtain working space. Be careful not to touch or bend the spring. Be careful not to lose the EMI suppressor.



- 9 Remove the large metal C-ring and the upper ceramic insulator if they were not attached to the lid.
- 10 Remove the collector. If the detector is operated at high temperatures, the collector parts may stick inside the detector. Gently push and wiggle them to break the seal.

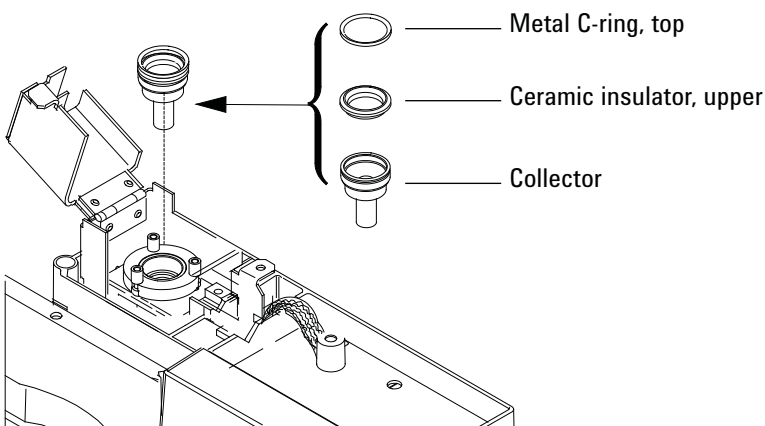

**Figure 7** NPD collector, upper insulator, and metal C-ring

- 11 Use tweezers to remove the lower ceramic insulator and the two small metal C-rings located above and below the collector. If these parts are stuck together, do not separate them. If they are not stuck, remember which metal ring was on top of the insulator and which was below it. The pieces must be reassembled in the same orientation.

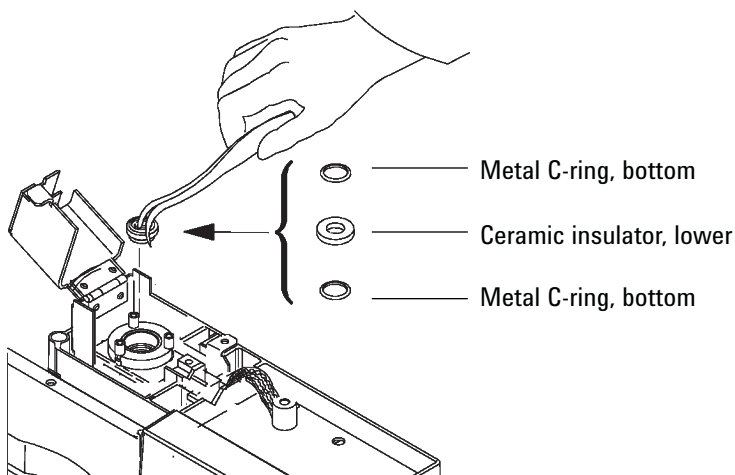

**Figure 8** NPD lower ceramic insulator and metal C-rings

- 12 If not replacing the jet, skip to [step 19](#).
- 13 Remove the column from the detector.

- 14 Loosen the jet with a nut driver.

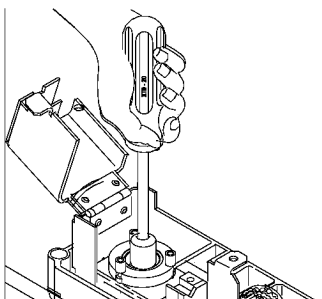

- 15 Pull the jet straight out of the detector. Use tweezers, if necessary.

**CAUTION**

The adaptable NPD jet is longer than the capillary optimized NPD extended jet and should never be installed in a capillary optimized detector.

- 16 Place the jet in the detector body.
- 17 Using a nut driver, tighten the jet 1/6 turn past finger-tight. *Do not overtighten.*
- 18 Attach the column to the detector. (See [“To Attach a Capillary Column Adapter on an Adaptable NPD”](#) on page 266.)
- 19 Use a cotton swab wetted with solvent to clean the residue from the inside of the collector and around the jet. If the collector appears very dirty, replace it with a new one.

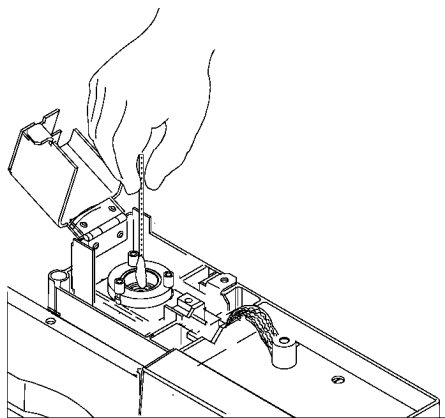

- 20 Install the bottom metal C-ring, the lower ceramic insulator, and the top metal C-ring. See [Figure 7](#).
- 21 Install the collector.

- 22** Install the upper ceramic insulator and top metal C-ring above the collector. See [Figure 8](#).
- 23** Install the lid, making sure that the NPD lid standoffs are in their slots. Hold the lid flat while each of the screws is tightened until they touch the lid. Tighten each screw evenly, 1/2 turn at a time, until tight. Do not overtighten.

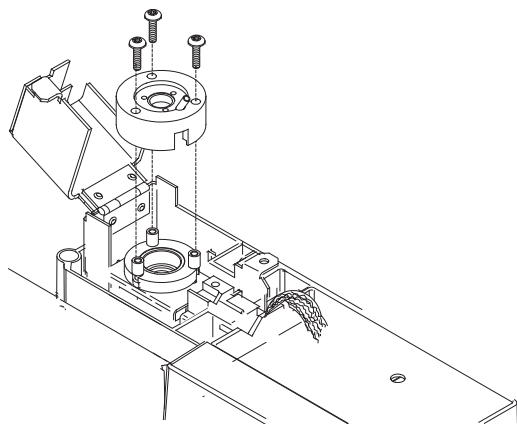

- 24** Slide the electrometer interconnect into the slot on the lid and lower the electrometer into the mounting tray. Be careful not to touch or bend the spring.

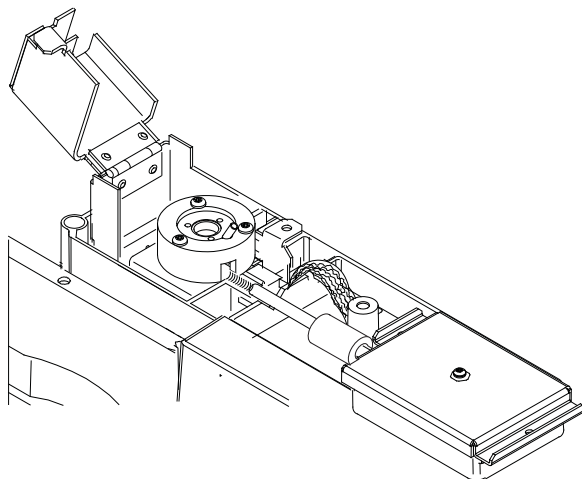

- 25** Install the J-clamp and screws to secure the electrometer to the pallet.

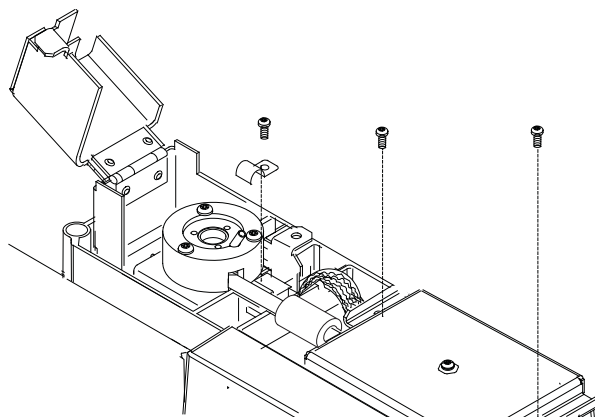

- 26** Install the bead assembly and restore normal operating conditions. (See [“To Replace the NPD Bead Assembly”](#) on page 272.) (Do not reset the bead counter unless replaced.)

After installing new collector parts, the NPD leakage current should be lower. (See [“To Check the NPD Leakage Current”](#) on page 285.) If the leakage current is abnormal, check for proper reassembly of the detector (especially where the electrometer interconnect contacts the collector assembly) and for leaks.

- 27** Reset the EMF counters. See [To Reset an EMF Counter](#) in the *Operation Manual*.

## To Check the NPD Leakage Current

- 1 Load the analytical method.
- 2 Set the **NPD Adjust Offset** to **Off** and the **Bead Voltage** to **0.00 V**.
  - Leave the NPD at operating temperature
  - Leave flows on or off
- 3 Press [**Front Detector**] or [**Back Detector**], then scroll to **Output**.
- 4 Verify that the output (leakage current) is stable and < 2.0 pA.

The output should slowly drop towards 0.0 pA, and should stabilize in the *tenths* of a picoamp. Current > 2.0pA indicates a problem.

## To Bakeout the NPD

**WARNING**

If using hydrogen as a carrier gas, turn off the hydrogen supply and cap the end of the column to prevent an oven explosion.

---

- 1 Bakeout the NPD with the column installed or uninstalled. If uninstalled, gather the following (see [“Consumables and Parts for the NPD”](#) on page 260):
  - Capillary adapter (adaptable NPD only)
  - Column nut
  - No-hole ferrule
- 2 Load the [GC maintenance method](#) and wait for the GC to become ready.

**WARNING**

Be careful! The detector may be hot enough to cause burns. If the detector is hot, wear heat-resistant gloves to protect your hands.

---

- 3 Set the bead voltage to 0, then turn it Off.
- 4 If the column is uninstalled, plug the detector connection with the capillary adapter, column nut, and no-hole ferrule.

Maintain inert carrier gas flow through the column, or remove the column from the GC.
- 5 Set normal operating flows.
- 6 Set the detector temperature at 25 °C above the typical method setpoint temperature.
- 7 Set the oven temperature to 250 °C or 25 °C above the normal maximum operating temperature. Do not exceed the column’s temperature limit.
- 8 Hold at temperature for 15 to 30 minutes.
- 9 If the column is not installed in the NPD, install it. (See [“To Install a Capillary Column in the NPD”](#) on page 268.)
- 10 Restore the analytical method and allow the NPD to equilibrate at operating temperatures and flows for 10 to 30 minutes.
- 11 Check the NPD leakage current. See [“To Check the NPD Leakage Current”](#) on page 285.

**12** Start the NPD bead Auto Adjust process. See the [7890 Series Advanced User Guide](#) for details.

Allow 4 to 24 hours for a new ceramic bead to equilibrate, or 1 to 2 hours for a new Blos bead.







## 15

### Maintaining the FPD<sup>+</sup>

- Consumables and Parts for the FPD<sup>+</sup> 290
- Exploded Parts View of the FPD<sup>+</sup> 292
- To Install a Packed Column Adapter in the FPD<sup>+</sup> 293
- To Attach a Capillary Column to the FPD<sup>+</sup> 295
- To Change the FPD<sup>+</sup> Wavelength Filter 297
- To Remove the FPD<sup>+</sup> Cover 300
- To Replace the FPD<sup>+</sup> Ignitor 302
- To Install the FPD<sup>+</sup> Cover 304
- Cleaning the FPD<sup>+</sup> Brazement 305



## Consumables and Parts for the FPD<sup>+</sup>

See the Agilent catalog for consumables and supplies for a more complete listing, or visit the Agilent Web site for the latest information ([www.agilent.com/chem/supplies](http://www.agilent.com/chem/supplies)).

**Table 45** FPD supplies

Description	Part number/quantity
Sulfur filter	1000-1437
Sulfur filter spacer	19256-20910
Phosphorus filter	19256-80010
Exit tube assembly	G3435-60330
O-ring for exit tube assembly	0905-1014
Ignitor	19256-60750
Screw, M3 × 6 mm, T-10	0515-0680
Collet	19256-20690
Column measuring tool	G3435-81380
Spring to secure photomultiplier tube	1460-1160
1/8-inch Packed column adapter assembly, includes:	G3435-60350
• 1/8-inch Packed column adapter, inert	G3435-60340
• 1/8-inch Packed column adapter nut	G3435-20375
• 1/8-inch Packed column adapter ferrule (10/pk)	5062-3538
Preventive maintenance kit, single FPD <sup>+</sup>	G3435-67000
Preventive maintenance kit, dual FPD <sup>+</sup>	G3436-67000

**Table 46** Nuts, ferrules, and hardware for capillary columns

Column id (mm)	Description	Typical use	Part number/quantity
.530	Ferrule, Vespel/graphite, 0.8-mm id	0.45-mm and 0.53-mm capillary columns	5062-3512 (10/pk)
	Ferrule, graphite, 1.0-mm id	0.53-mm capillary columns	5080-8773 (10/pk)
	Ferrule, graphite, 0.8-mm id	0.53-mm capillary columns	500-2118 (10/pk)
	Column nut, finger-tight (for 0.53-mm columns)	Connect column to inlet or detector	5020-8293
.320	Ferrule, Vespel/graphite, 0.5-mm id	0.32-mm capillary columns	5062-3514 (10/pk)
	Ferrule, graphite, 0.5-mm id	0.1-mm, 0.2-mm, 0.25-mm, and 0.32-mm capillary columns	5080-8853 (10/pk)
	Column nut, finger-tight (for .100- to .320-mm columns)	Connect column to inlet or detector	5020-8292
.250	Ferrule, Vespel/graphite, 0.4-mm id	0.1-mm, 0.2-mm, and 0.25-mm capillary columns	5181-3323 (10/pk)
	Ferrule, graphite, 0.5-mm id	0.1-mm, 0.2-mm, 0.25-mm, and 0.32-mm capillary columns	5080-8853 (10/pk)
	Column nut, finger-tight (for .100- to .320-mm columns)	Connect column to inlet or detector	5020-8292
.100 and .200	Ferrule, Vespel/graphite, 0.37-mm id	0.1-mm and 0.2-mm capillary columns	5062-3516 (10/pk)
	Ferrule, Vespel/graphite, 0.4-mm id	0.1-mm, 0.2-mm, and 0.25-mm capillary columns	5181-3323 (10/pk)
	Ferrule, graphite, 0.5-mm id	0.1-mm, 0.2-mm, 0.25-mm, and 0.32-mm capillary columns	5080-8853 (10/pk)
	Ferrule, graphite, 0.4-mm id		500-2114 (10/pk)
	Column nut, finger-tight (for .100- to .320-mm columns)	Connect column to inlet or detector	5020-8292
All	Ferrule, no-hole	Testing	5181-3308 (10/pk)
	Capillary column blanking nut	Testing—use with any ferrule	5020-8294
	Column nut, universal	Connect column to inlet or detector	5181-8830 (2/pk)
	Column cutter, ceramic wafer	Cutting capillary columns	5181-8836 (4/pk)
	Pencil, diamond tipped	Cutting capillary columns	420-1000
	Ferrule tool kit	Ferrule installation	440-1000

## Exploded Parts View of the FPD<sup>+</sup>

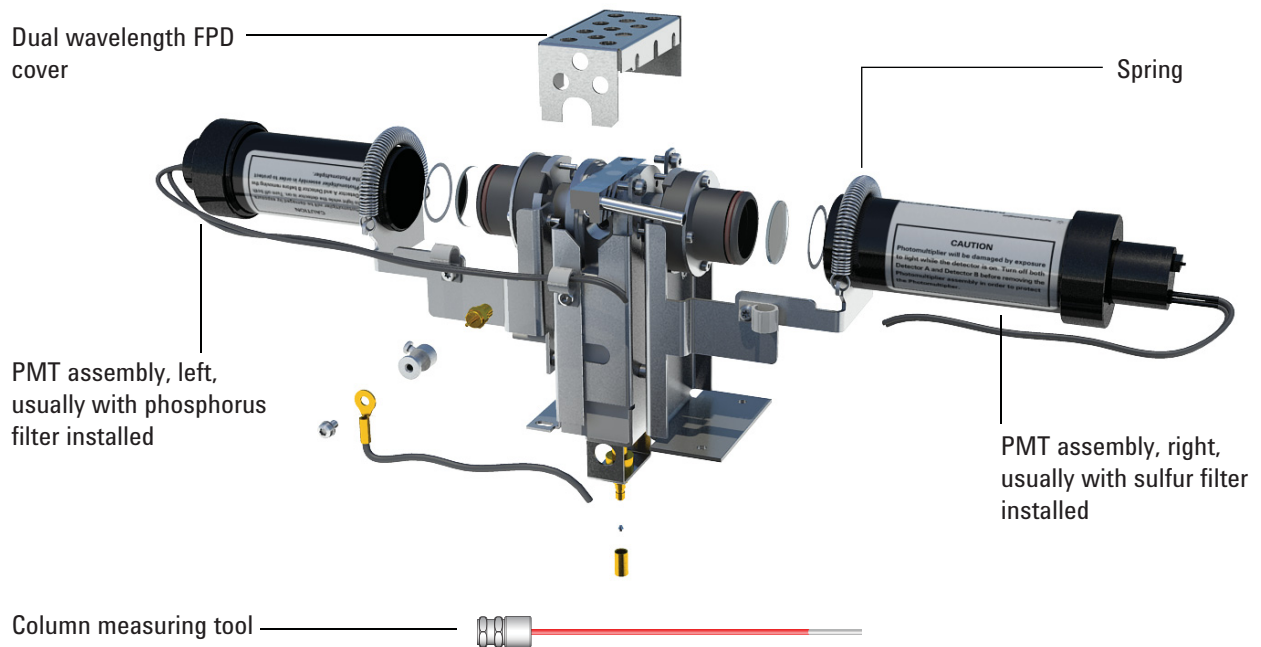
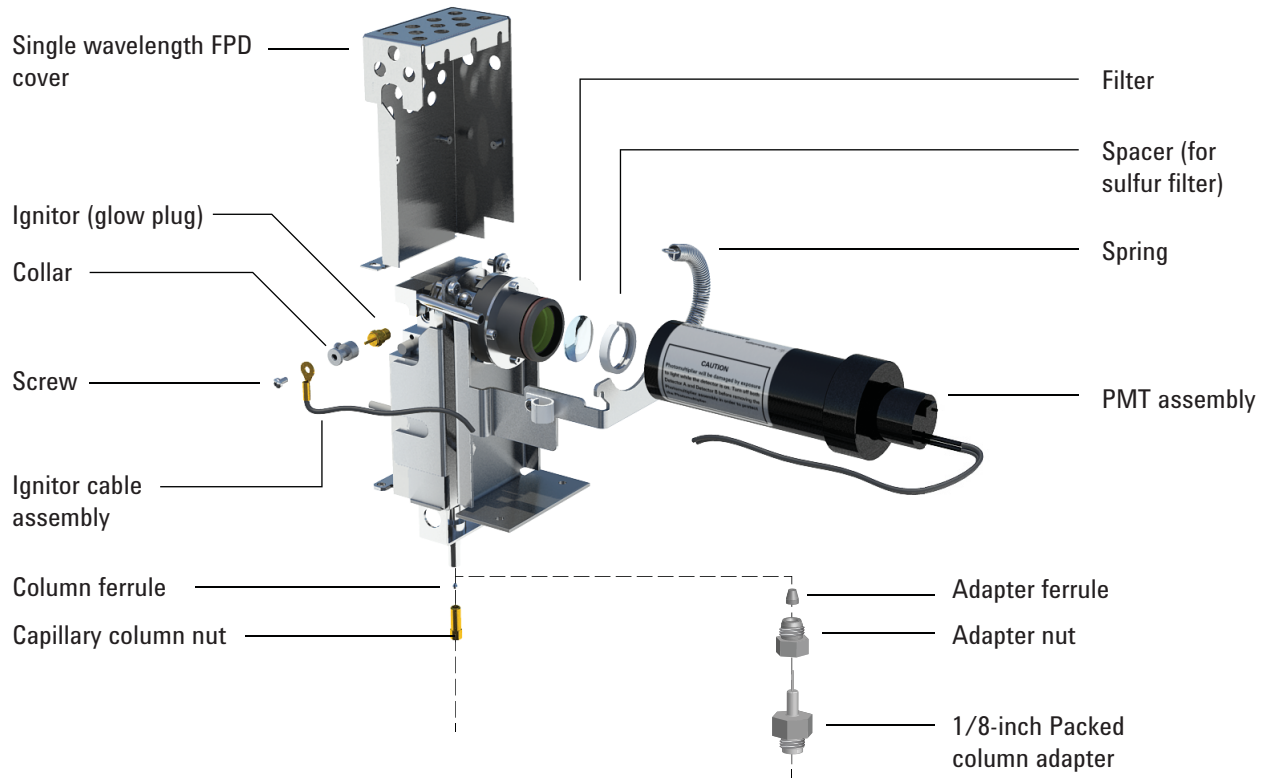

## To Install a Packed Column Adapter in the FPD<sup>+</sup>

This procedure applies to 1/8-inch packed metal columns.

- Gather the following:
  - FPD packed column adapter (See “Consumables and Parts for the FPD<sup>+</sup>” on page 290.)
  - Polyimide ferrule for 530- $\mu$ m column
  - 7/16-inch wrench
  - 5/16-inch wrench
  - 1/8-inch nut and ferrule for a 1/8-inch packed column
  - Adapter nut
  - Lint-free gloves
- Load the [GC maintenance method](#) and wait for the GC to become ready.

### WARNING

**Be careful! The oven and/or detector may be hot enough to cause burns. If the detector is hot, wear gloves to protect your hands.**

### CAUTION

Wear clean, lint-free gloves to prevent contamination of parts with dirt and skin oils.

- Place a 1/8-inch nut and ferrule onto the packed column.

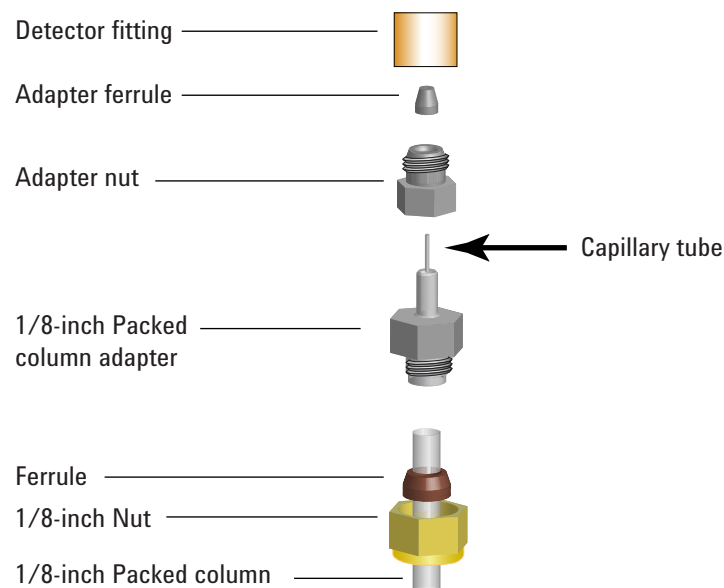

- 4 Install the 1/8-inch packed metal column onto the column adapter.
- 5 Finger-tighten the column, then tighten an additional 1/8 turn using two wrenches.

**CAUTION**

Handle the adapter carefully and install the packed column before installing the adapter into the detector base. The thin-walled capillary tube that carries the sample into the detector can be damaged by rough handling.

---

- 6 Place the adapter nut and ferrule onto the adapter.
- 7 Carefully install the adapter assembly into the detector fitting. Align the adapter so the it enters the detector fitting as vertically as possible. Avoid stressing the adapter capillary tube. The adapter nut should turn freely.

## To Attach a Capillary Column to the FPD<sup>+</sup>

- 1 Gather the following:
  - Column measuring tool (See “Consumables and Parts for the FPD<sup>+</sup>” on page 290.)
  - Column cutter
  - 1/4-inch and 7/16-inch wrenches
  - Column nut
  - Ferrule
  - Capillary column
  - Lint-free gloves
- 2 Load the [GC maintenance method](#) and wait for the GC to become ready.

**WARNING**

**Be careful! The oven and/or detector may be hot enough to cause burns. If the detector is hot, wear gloves to protect your hands.**

---

**WARNING**

**Wear safety glasses to protect your eyes from flying particles while handling, cutting, or installing glass or fused silica capillary columns. Use care in handling these columns to prevent puncture wounds.**

---

**CAUTION**

**Wear clean, lint-free gloves to prevent contamination of parts with dirt and skin oils.**

---

- 3 Assemble a septum, column nut, and ferrule on the end of the column.

- 4 Insert the end of the column through the column measuring tool so that the end protrudes beyond the tool.

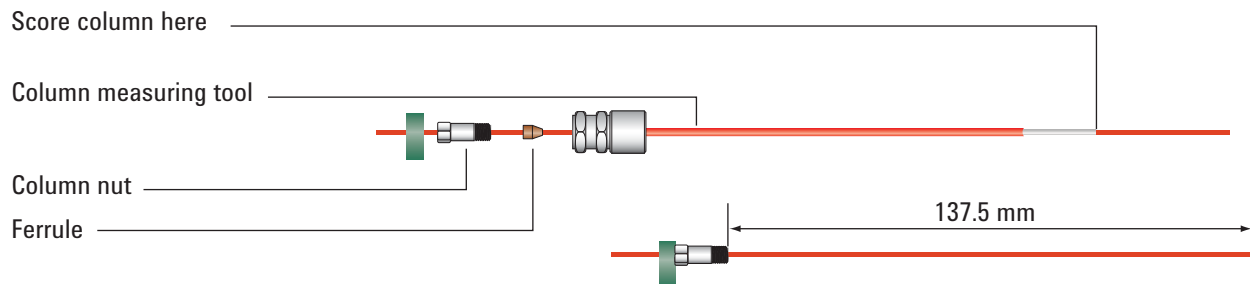

- 5 Tighten the column nut until it grips the column. Tighten the nut an additional 1/8 to 1/4 turn with a pair of wrenches. Snug the septum against the base of the column nut.
- 6 Use a wafer cutter at 45° to score the column.
- 7 Snap off the column end. The column may protrude about 1 mm beyond the end of the tool. Inspect the end with a magnifying loupe to make certain that there are no burrs or jagged edges.

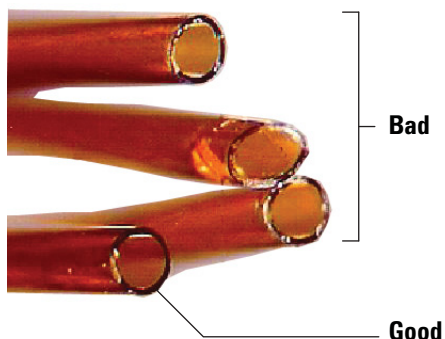

- 8 Remove the column, nut, and swaged ferrule from the tool.
- 9 Wipe the column walls with a tissue dampened with isopropanol to remove fingerprints and dust.
- 10 Carefully thread the swaged column up into the detector fitting. Finger-tighten the column nut, then use a wrench to tighten an additional 1/8 turn.



## To Change the FPD<sup>+</sup> Wavelength Filter

**CAUTION**

Do not touch the filter with your bare hands. For optimum performance and to avoid scratches, use lint-free gloves for assembling and inserting the filter into the assembly.

---

- 1 Gather the following:
  - Sulfur filter with filter spacer (See “Consumables and Parts for the FPD<sup>+</sup>” on page 290.)
  - Phosphorus filter
  - Cotton swab
  - Lens tissue
  - Lint-free gloves
- 2 Load the [GC maintenance method](#) and wait for the GC to become ready.
- 3 Turn off the photomultiplier tube (PMT).
  - a Select **[Front Det]** or **[Back Det]**.
  - b Scroll to **PMT voltage**.
  - c Press **Off**.

**WARNING**

**Be careful! The detector may be hot enough to cause burns. If the detector is hot, wear heat-resistant gloves to protect your hands.**

---

**CAUTION**

The photomultiplier tube (PMT) is extremely sensitive to light. Always turn off the electrometer (which turns off the high voltage to the PMT) before removing the PMT housing or opening the emissions chamber. Failing to do this can destroy the PMT.

Even with the electrometer off, protect the PMT from room light. Cap the housing after it is removed, place it end down to exclude light, or reduce the room light level before exposing the PMT. A brief exposure (always with the electrometer turned off) will not damage it, but prolonged exposure will cause a gradual loss of sensitivity.

---

- 4 Disconnect the retaining spring that holds the PMT assembly to the bracket. With a rotating motion, pull the assembly away from the filter housing.



- 5 To prevent light from damaging the PMT, cap the end or place it face down.

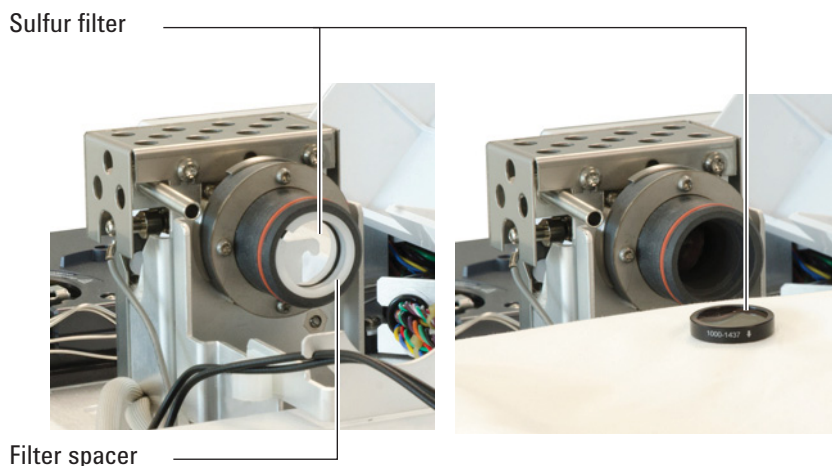

- 6 Place a clean cloth under the filter housing to catch the filter.
- For phosphorus filter, use the sharpened wooden tip of a toothpick or cotton swab to dislodge the filter from the housing.
  - For sulfur filter (shown below), use the wooden tip of the cotton swab to remove the filter spacer. Then dislodge the filter from the housing.

**CAUTION**

Do not use cleaning fluids. Cleaning fluids will damage lens coatings.

7 Clean the new filter with lens tissue.

**CAUTION**

Filters are designed for the light of the flame to pass through in a specific direction. The triangle (on the edge of the phosphorus filter) and the arrow (on the edge of the sulfur filter) should face *away* from the flame and *toward* the PMT.

8 Install the filter in the filter housing. Install the sulfur filter spacer, if necessary.

9 Replace the PMT assembly and secure with the spring.

10 Route the PMT wires through the clips as shown. Avoid placing the wires very near heated areas (such as the emission block or oven top).

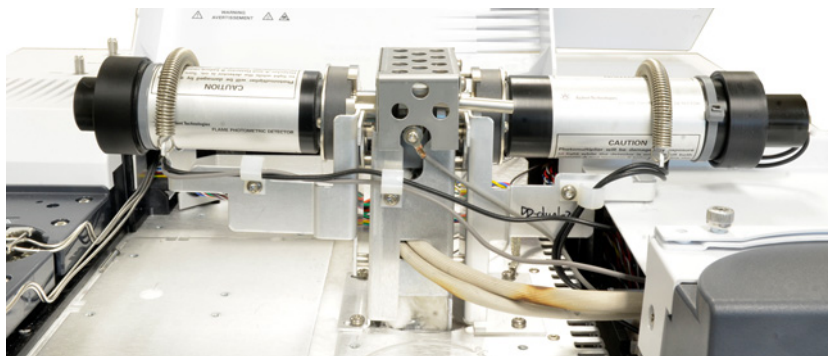

11 Restore the analytical method.

## To Remove the FPD<sup>+</sup> Cover

- 1 Gather the following:
  - T-20 Torx screwdriver
- 2 Load the [GC maintenance method](#) and wait for the GC to become ready.

**CAUTION**

When turning off the GC, first turn off the flame to prevent condensation from dripping into the jet and column.

---

**WARNING**

**Be careful! The detector may be hot enough to cause burns. If the detector is hot, wear heat-resistant gloves to protect your hands.**

---

- 3 Open the FPD detector top cover.
- 4 Loosen the screws securing the FPD cover to the top of the detector.

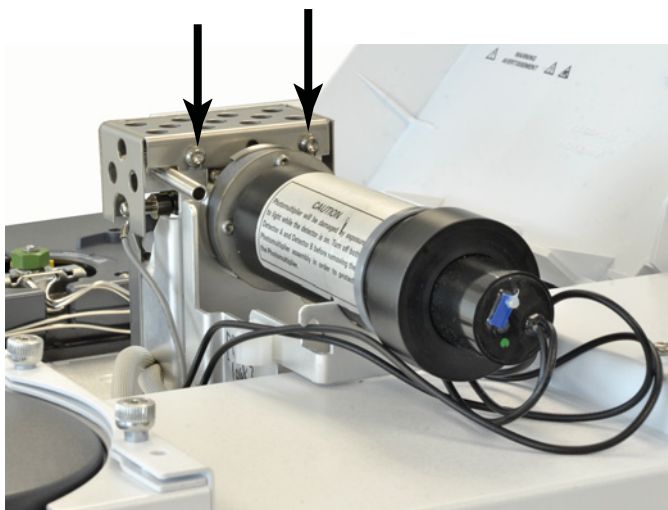

- 5 For a single wavelength FPD, remove the two screws at the bottom left of the cover.

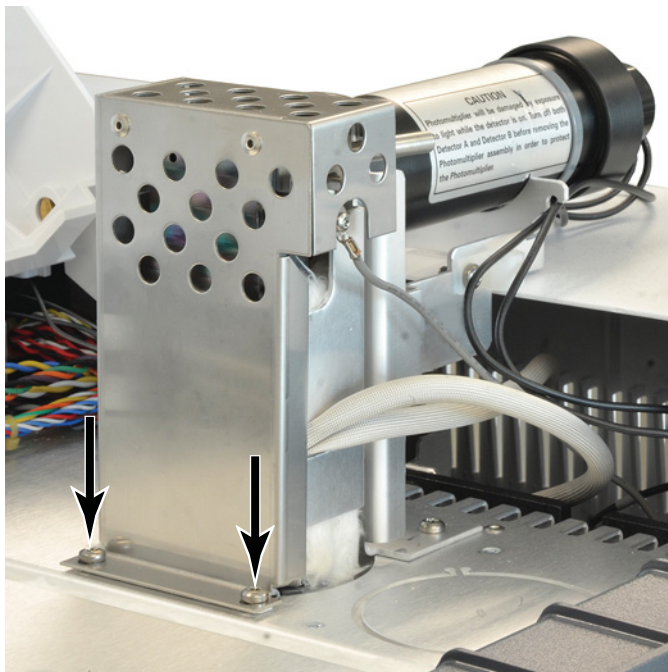

- 6 Lift the cover off the detector.

## To Replace the FPD<sup>+</sup> Ignitor

- 1 Gather the following:
  - Ignitor replacement kit. (See “Consumables and Parts for the FPD<sup>+</sup>” on page 290.)
  - Torx screwdrivers, T-20 and T-10
  - 5/16-inch nut driver (or wrench)
- 2 Load the [GC maintenance method](#) and wait for the GC to become ready.

**WARNING**

**Be careful! The detector may be hot enough to cause burns. If the detector is hot, wear heat-resistant gloves to protect your hands.**

- 3 Remove the FPD cover. (See “To Remove the FPD<sup>+</sup> Cover” on page 300.)
- 4 Loosen the collet screw holding the cable assembly to the ignitor. Remove the collet and cable assembly.

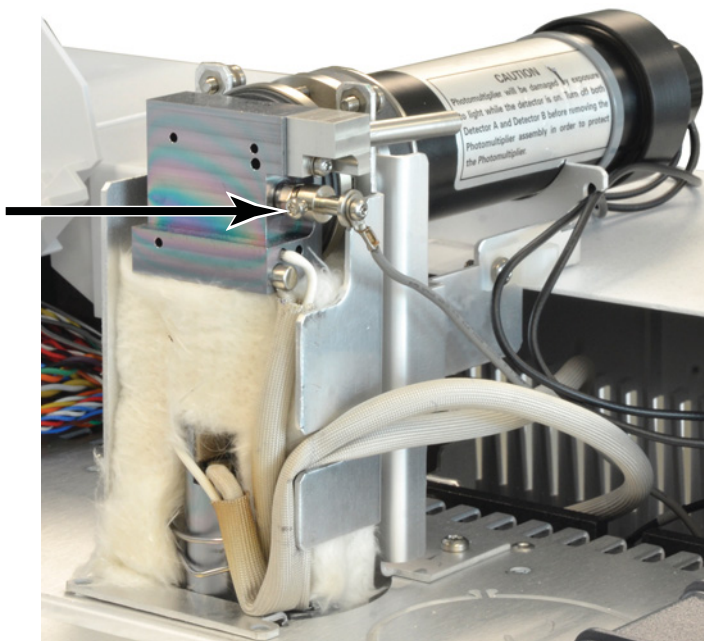

- 5 Use a nut driver to loosen and remove the glow plug.
  - If using a 5/16-inch wrench, you may need to remove the exit tube assembly using a T-10 Torx driver

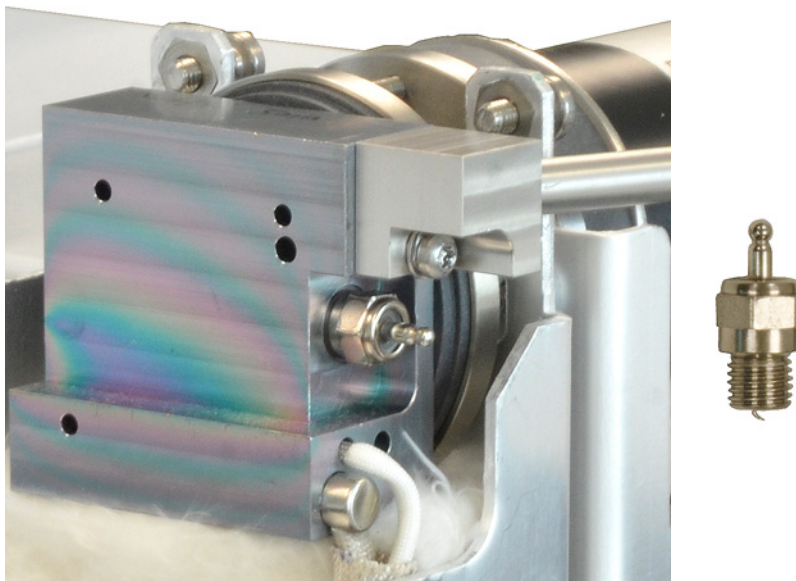

- 6 Install the new ignitor assembly and tighten with the nut driver. Do not overtighten. (If the ignitor comes with a copper washer, discard the copper washer.)
- 7 Replace the ignitor collet and cable assembly and tighten the screw. Align the collet set screw as shown. Do not let the collet screw touch metal parts, such as the emission block or PMT bracket (dual wavelength detector).

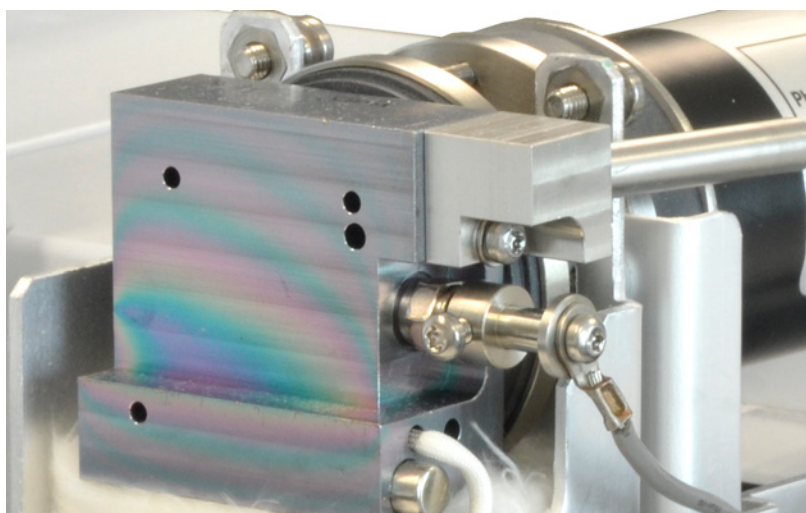

- 8 Replace the FPD cover. (See [“To Install the FPD<sup>+</sup> Cover”](#) on page 304.)
- 9 Restore the analytical method.
- 10 Wait 20 min. for the detector to heat up, then ignite the flame.
- 11 Reset the EMF counter. See [To Reset an EMF Counter](#) in the *Operation Manual*.

## To Install the FPD<sup>+</sup> Cover

1 Gather the following:

- T-20 Torx screwdriver

2 Install the cover.

Single-wavelength detector:

- a Start the two screws on the right side of the cover.
- b Start and tighten the screws at the base on the left side.
- c Tighten the screws on the right side.

Dual-wavelength detector: Install the cover (two screws).

3 Close the FPD detector top cover.



## Cleaning the FPD<sup>+</sup> Brazement

### CAUTION

The brazement uses an inert coating layer. Abrasives may scratch this layer. Hard scrubbing can scratch this layer. Solutions or soaps with a pH > 8 can also damage this layer. Do not steam clean.

---

The FPD<sup>+</sup> brazement, which consists of the transfer line and emission block assemblies, uses an inert coating layer to provide better performance. Normally, manually cleaning the brazement is not required. However, if it becomes necessary to clean the brazement to remove contamination, note that exposing the inert coating to abrasives or certain solvents will degrade the coating. If cleaning is needed, follow the recommendations below for best results:

- Rinse with a solvent appropriate to dissolve the expected contaminants. Avoid abrasive or highly basic solutions (see the caution above). Recommended solvents: dichloromethane, acetone, or methanol.
- Mildly sonicate if needed, but excessive sonication can damage the coating layer.
- Gently remove solids using a soft, nylon bristle brush. Do not scrub hard. Recommended brush: Use the MMI inlet cleaning brush from the MMI cleaning kit (G3510-80820). (Do **NOT** use the MMI inlet abrasive cleaning swab, G3510-80829.)

## 15 Maintaining the FPD<sup>+</sup>



## 16 Maintaining the G3435A/G3436A FPD

Consumables and Parts for the FPD	308
Exploded Parts View of the FPD	310
To Install a Capillary Column Adapter in the FPD	311
To Attach a Capillary Column to the FPD	313
To Change the FPD Wavelength Filter	315
To Remove the FPD Vent Tube	318
To Replace the FPD Ignitor	320
To Install the FPD Vent Tube and Cover	322

This section describes how to maintain the Agilent G3435A/G3436A Single or Dual Flame Photometric detector. This detector is typically available only on a 7890A GC; however, this detector may be available on a 7890B GC which has been upgraded from a 7890A. To determine the FPD version, lift the detector top cover and locate the metal FPD cover (see [“Exploded Parts View of the FPD”](#) on page 310). If the cover is solid, the FPD is a G3435A or G3436A. Refer to the maintenance procedures in this section. If the cover is perforated (has round vent holes), the detector is an FPD<sup>+</sup> (see [“Maintaining the FPD<sup>+</sup>”](#) on page 289).



## Consumables and Parts for the FPD

See the Agilent catalog for consumables and supplies for a more complete listing, or visit the Agilent Web site for the latest information ([www.agilent.com/chem/supplies](http://www.agilent.com/chem/supplies)).

**Table 47** FPD supplies

Description	Part number/quantity
Sulfur filter	1000-1437
Sulfur filter spacer	19256-20910
Phosphorus filter	19256-80010
Exit tube assembly, aluminum	19256-60700
Exit tube assembly, stainless steel	19256-20705
Ferrule, Vespel, 1/4-inch id, 10/pk	5080-8774
Ferrule, 1/4-inch id, front, 10/pk	5180-4111
Ferrule, 1/4-inch id, back, 10/pk	5180-4117
Ignitor replacement kit <ul style="list-style-type: none"> <li>• O-ring</li> <li>• Spacer</li> <li>• Glow plug</li> </ul>	19256-60800
Screw, M3 × 66 mm, T-10	0515-0680
Collar	19256-20690
Capillary adapter nut	19256-21150
Capillary adapter seat	19256-21140
1/4-inch packed adapter	G1532-20710
Column measuring tool	19256-80640
Spring to secure photomultiplier tube	1460-1160
1/8-inch packed adapter nut	0100-0057
1/8-inch Vespel ferrule for packed adapter	0100-1332

**Table 48** Nuts, ferrules, and hardware for capillary columns

Column id (mm)	Description	Typical use	Part number/quantity
.530	Ferrule, Vespel/graphite, 0.8-mm id	0.45-mm and 0.53-mm capillary columns	5062-3512 (10/pk)
	Ferrule, graphite, 1.0-mm id	0.53-mm capillary columns	5080-8773 (10/pk)
	Ferrule, graphite, 0.8-mm id	0.53-mm capillary columns	500-2118 (10/pk)
	Column nut, finger-tight (for 0.53-mm columns)	Connect column to inlet or detector	5020-8293
.320	Ferrule, Vespel/graphite, 0.5-mm id	0.32-mm capillary columns	5062-3514 (10/pk)
	Ferrule, graphite, 0.5-mm id	0.1-mm, 0.2-mm, 0.25-mm, and 0.32-mm capillary columns	5080-8853 (10/pk)
	Column nut, finger-tight (for .100- to .320-mm columns)	Connect column to inlet or detector	5020-8292
.250	Ferrule, Vespel/graphite, 0.4-mm id	0.1-mm, 0.2-mm, and 0.25-mm capillary columns	5181-3323 (10/pk)
	Ferrule, graphite, 0.5-mm id	0.1-mm, 0.2-mm, 0.25-mm, and 0.32-mm capillary columns	5080-8853 (10/pk)
	Column nut, finger-tight (for .100- to .320-mm columns)	Connect column to inlet or detector	5020-8292
.100 and .200	Ferrule, Vespel/graphite, 0.37-mm id	0.1-mm and 0.2-mm capillary columns	5062-3516 (10/pk)
	Ferrule, Vespel/graphite, 0.4-mm id	0.1-mm, 0.2-mm, and 0.25-mm capillary columns	5181-3323 (10/pk)
	Ferrule, graphite, 0.5-mm id	0.1-mm, 0.2-mm, 0.25-mm, and 0.32-mm capillary columns	5080-8853 (10/pk)
	Ferrule, graphite, 0.4-mm id		500-2114 (10/pk)
	Column nut, finger-tight (for .100- to .320-mm columns)	Connect column to inlet or detector	5020-8292
All	Ferrule, no-hole	Testing	5181-3308 (10/pk)
	Capillary column blanking nut	Testing—use with any ferrule	5020-8294
	Column nut, universal	Connect column to inlet or detector	5181-8830 (2/pk)
	Column cutter, ceramic wafer	Cutting capillary columns	5181-8836 (4/pk)
	Pencil, diamond tipped	Cutting capillary columns	420-1000
	Ferrule tool kit	Ferrule installation	440-1000

## Exploded Parts View of the FPD

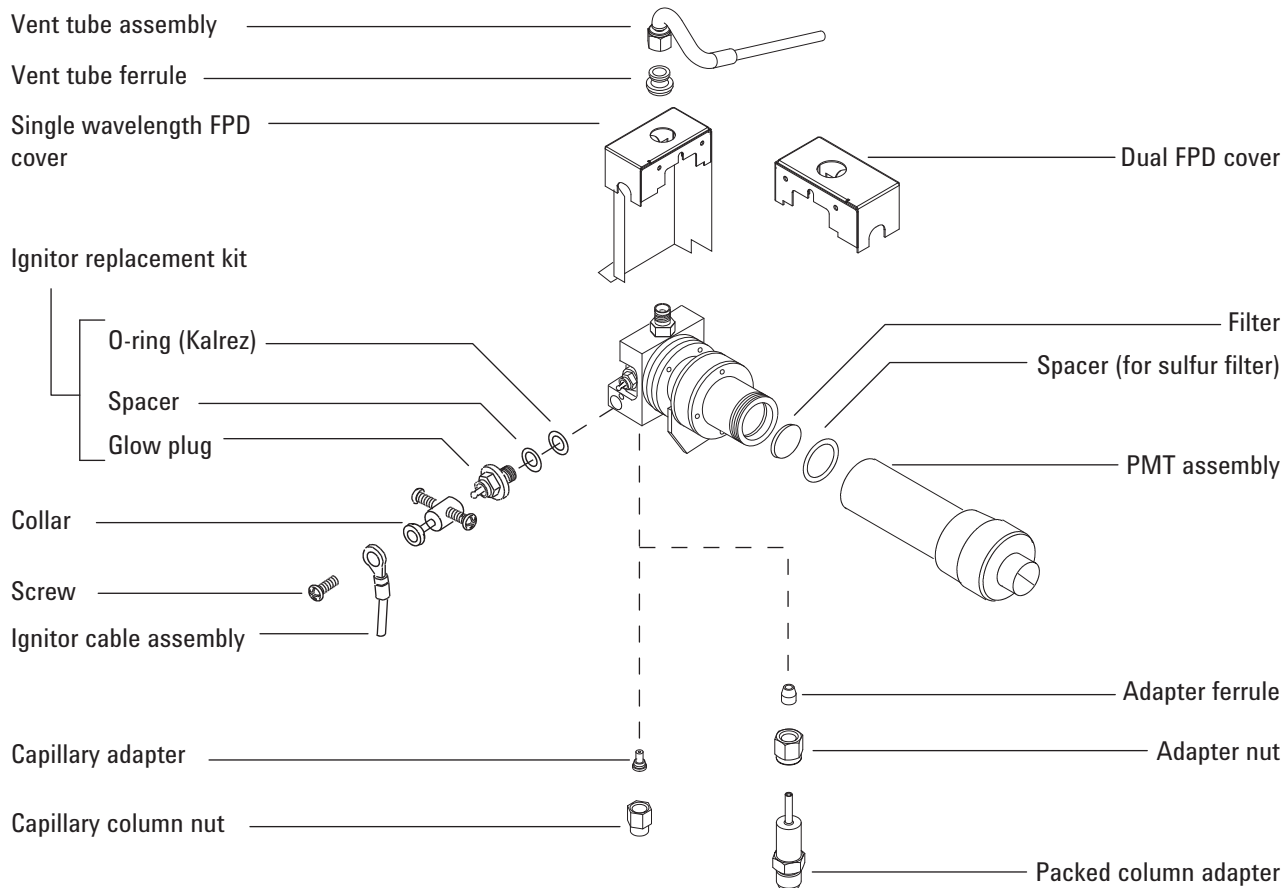

## To Install a Capillary Column Adapter in the FPD

- 1 Gather the following:
  - FPD capillary column adapter (See “Consumables and Parts for the FPD” on page 308.)
  - Column cutter
  - 1/4-inch wrench
  - 9/16-inch wrench
  - Metric ruler
  - 1/8-inch nut
  - Lint-free gloves
- 2 Load the [GC maintenance method](#) and wait for the GC to become ready.

**WARNING**

**Be careful! The oven and/or detector may be hot enough to cause burns. If the detector is hot, wear gloves to protect your hands.**

---

**WARNING**

**Wear safety glasses to protect your eyes from flying particles while handling, cutting, or installing glass or fused silica capillary columns. Use care in handling these columns to prevent puncture wounds.**

---

**CAUTION**

Wear clean, lint-free gloves to prevent contamination of parts with dirt and skin oils.

---

- 3 Insert the capillary adapter into the 1/8-inch nut as shown, then thread the nut onto the detector fitting.

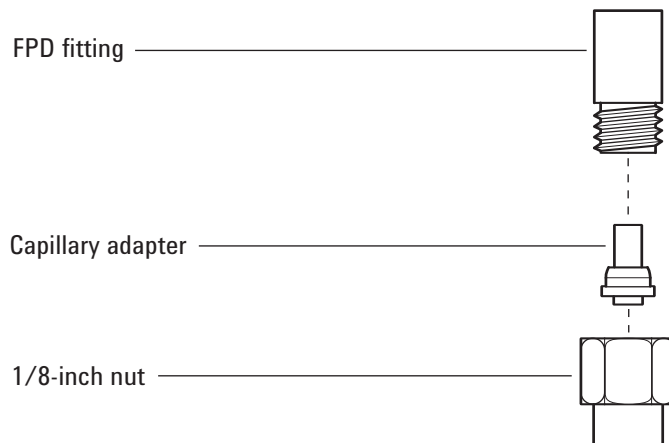

- 4 Finger-tighten the nut, then tighten an additional 1/8 turn with a wrench.



## To Attach a Capillary Column to the FPD

- 1 Gather the following:
  - Column measuring tool (See “Consumables and Parts for the FPD” on page 308.)
  - Column cutter
  - 1/4-inch and 7/16-inch wrenches
  - Column nut
  - Ferrule
  - Capillary column
  - Lint-free gloves
- 2 Load the [GC maintenance method](#) and wait for the GC to become ready.

**WARNING**

**Be careful! The oven and/or detector may be hot enough to cause burns. If the detector is hot, wear gloves to protect your hands.**

---

**WARNING**

**Wear safety glasses to protect your eyes from flying particles while handling, cutting, or installing glass or fused silica capillary columns. Use care in handling these columns to prevent puncture wounds.**

---

**CAUTION**

Wear clean, lint-free gloves to prevent contamination of parts with dirt and skin oils.

---

- 3 Assemble a septum, column nut, and ferrule on the end of the column.
- 4 Insert the end of the column through the column measuring tool so that the end protrudes beyond the tool.

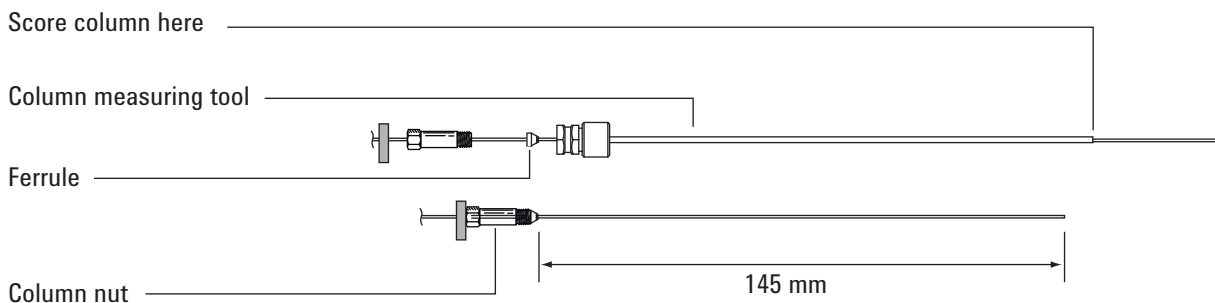

- 5 Tighten the column nut until it grips the column. Tighten the nut an additional 1/8 to 1/4 turn with a pair of wrenches. Snug the septum against the base of the column nut.
- 6 Use a wafer cutter at 45° to score the column.
- 7 Snap off the column end. The column may protrude about 1 mm beyond the end of the tool. Inspect the end with a magnifying loupe to make certain that there are no burrs or jagged edges.

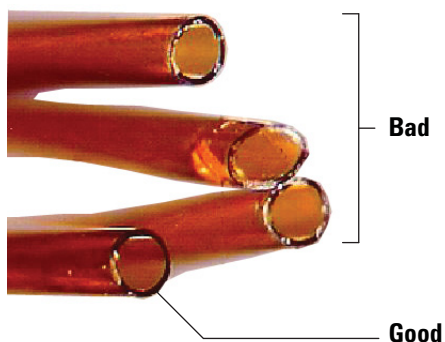

- 8 Remove the column, nut, and swaged ferrule from the tool.
- 9 Wipe the column walls with a tissue dampened with isopropanol to remove fingerprints and dust.
- 10 Verify that a capillary adapter is installed in the detector fitting. (See [“To Install a Capillary Column Adapter in the FPD”](#) on page 311.)
- 11 Carefully thread the swaged column up into the adapter. Finger-tighten the column nut, then use a wrench to tighten an additional 1/8 turn.

## To Change the FPD Wavelength Filter

**CAUTION**

Do not touch the filter with your bare hands. For optimum performance and to avoid scratches, use lint-free gloves for assembling and inserting the filter into the assembly.

---

- 1 Gather the following:
  - Sulfur filter with filter spacer (See “Consumables and Parts for the FPD” on page 308.)
  - Phosphorus filter
  - Cotton swab
  - Lens tissue
  - Lint-free gloves
- 2 Load the [GC maintenance method](#) and wait for the GC to become ready.
- 3 Turn off the photomultiplier tube (PMT).
  - a Select **[Front Det]** or **[Back Det]**.
  - b Scroll to **PMT voltage**.
  - c Press **Off**.

**WARNING**

**Be careful! The detector may be hot enough to cause burns. If the detector is hot, wear heat-resistant gloves to protect your hands.**

---

**CAUTION**

The photomultiplier tube (PMT) is extremely sensitive to light. Always turn off the electrometer (which turns off the high voltage to the PMT) before removing the PMT housing or opening the emissions chamber. Failing to do this can destroy the PMT.

Even with the electrometer off, protect the PMT from room light. Cap the housing after it is removed, place it end down to exclude light, or reduce the room light level before exposing the PMT. A brief exposure (always with the electrometer turned off) will not damage it, but prolonged exposure will cause a gradual loss of sensitivity.

---

- 4 Disconnect the retaining spring that holds the PMT assembly to the bracket. With a rotating motion, pull the assembly away from the filter housing.

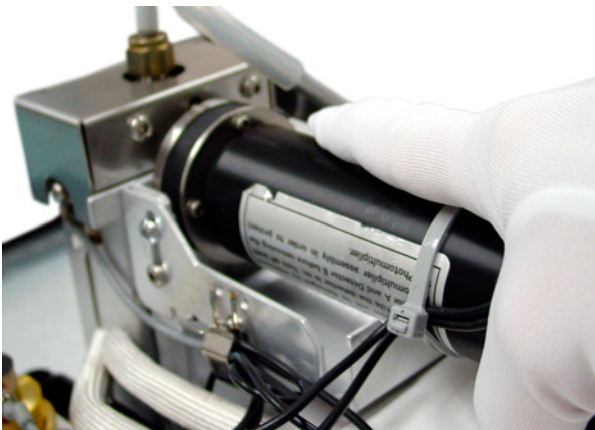

- 5 To prevent light from damaging the PMT, cap the end or place it face down.

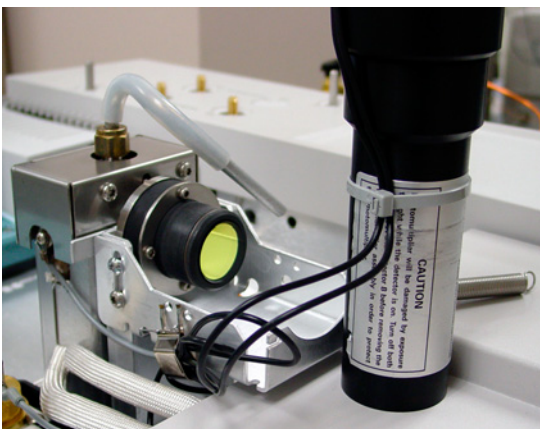

- 6 Place a clean cloth under the filter housing to catch the filter.
  - For phosphorus filter, use the sharpened wooden tip of a toothpick or cotton swab to dislodge the filter from the housing.
  - For sulfur filter (shown below), use the wooden tip of the cotton swab to remove the filter spacer. Then dislodge the filter from the housing.

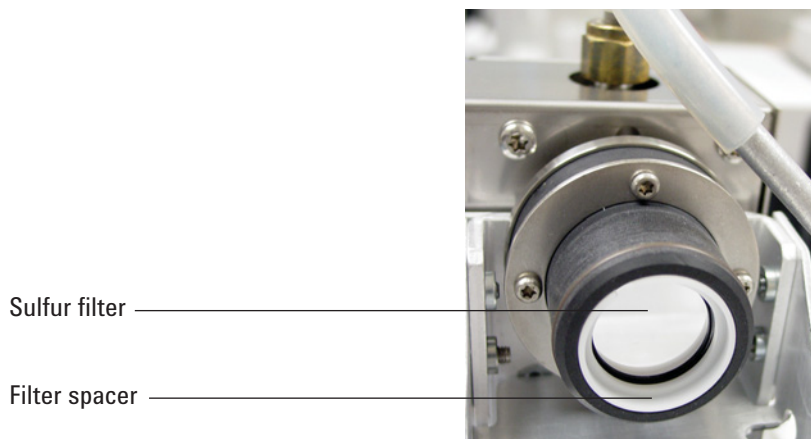
**CAUTION**

Do not use cleaning fluids. Cleaning fluids will damage lens coatings.

7 Clean the new filter with lens tissue.

**CAUTION**

Filters are designed for the light of the flame to pass through in a specific direction. The triangle (on the edge of the phosphorus filter) and the arrow (on the edge of the sulfur filter) should face *away* from the flame and *toward* the PMT.

8 Install the filter in the filter housing. Install the sulfur filter spacer, if necessary.

9 Replace the PMT assembly and secure with the spring.

10 Restore the analytical method.

## To Remove the FPD Vent Tube

- 1 Gather the following:
  - T-20 Torx screwdriver
  - 9/16-inch wrench
- 2 Load the [GC maintenance method](#) and wait for the GC to become ready.

### CAUTION

When turning off the GC, first turn off the flame to prevent condensation from dripping into the jet and column.

### WARNING

**Be careful! The detector may be hot enough to cause burns. If the detector is hot, wear heat-resistant gloves to protect your hands.**

- 3 Drain any water from the flexible vent tubing and discard.
- 4 Open the FPD cover.
- 5 Remove the flexible tubing from the FPD vent tube.
- 6 Loosen and remove the vent tube assembly with a wrench.

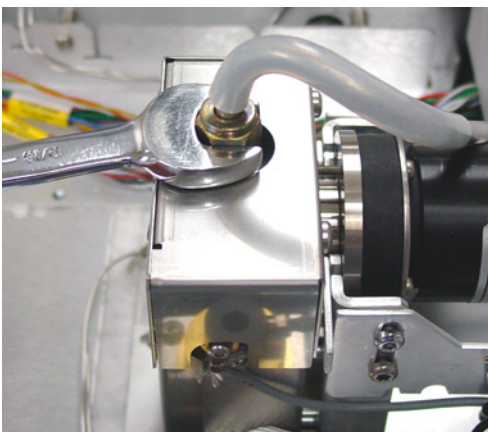

- 7 Remove the screws securing the FPD cover.
  - The single-wavelength detector has two screws at the bottom of the left side (top photo below) and two screws at the top of the right side (bottom photo below).
  - The dual-wavelength detector has two screws at the top of the right side (bottom photo below).

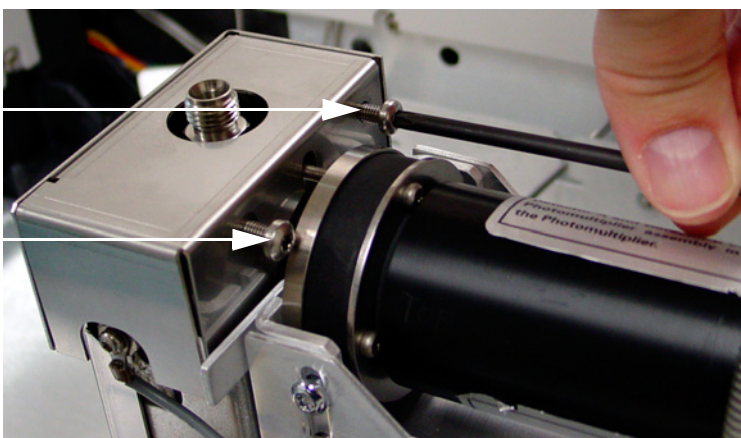
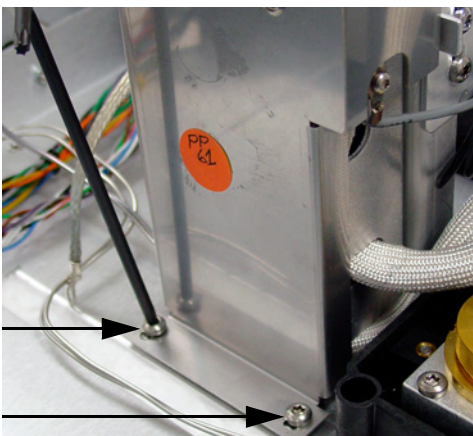

8 Lift the cover off the detector.

## To Replace the FPD Ignitor

- 1 Gather the following:
  - Ignitor replacement kit. (See “Consumables and Parts for the FPD” on page 308.)
  - Torx screwdrivers, T-20 and T-10
  - 9/16-inch wrench
  - Tweezers
- 2 Load the [GC maintenance method](#) and wait for the GC to become ready.

**WARNING**

**Be careful! The detector may be hot enough to cause burns. If the detector is hot, wear heat-resistant gloves to protect your hands.**

---

- 3 Remove the vent tube assembly and cover. (See “To Remove the FPD Vent Tube” on page 318.)
- 4 Loosen the collar screw (some have two screws) holding the cable assembly to the ignitor. Remove the collar and cable assembly.

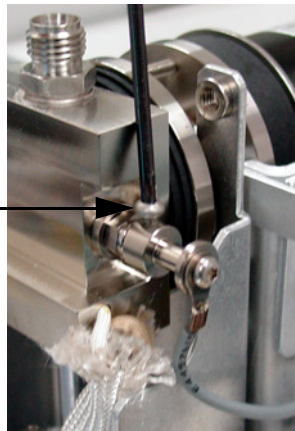

- 5 Use a wrench to loosen and remove the glow plug.



- 6 Remove the O-ring with tweezers.
- 7 Assemble the parts for the new ignitor.

Glow plug

Spacer

O-ring



- 8 Install the new ignitor assembly and tighten with a wrench. Do not overtighten.
- 9 Replace the ignitor collar and cable assembly and tighten the screw.

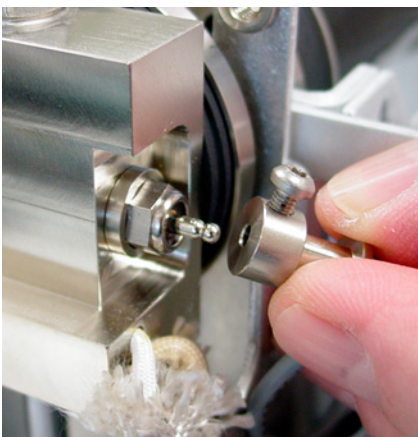

- 10 Replace the cover and the vent tube assembly. (See [“To Install the FPD Vent Tube and Cover”](#) on page 322.)
- 11 Restore the analytical method.
- 12 Wait 20 minutes for the detector to heat up, then ignite the flame.
- 13 Reset the EMF counter. See [To Reset an EMF Counter](#) in the *Operation Manual*.

## To Install the FPD Vent Tube and Cover

1 Gather the following:

- T-20 Torx screwdriver
- 9/16-inch wrench

2 Install the cover.

Single-wavelength detector:

- a Start the two screws on the right side of the cover.
- b Start and tighten the screws at the base on the left side.
- c Tighten the screws on the right side.

Dual-wavelength detector: Install the cover (two screws).

3 Install the vent tube assembly.

4 Reconnect the flexible tubing to the vent tube assembly and route the open end to waste.

5 Close the FPD cover.

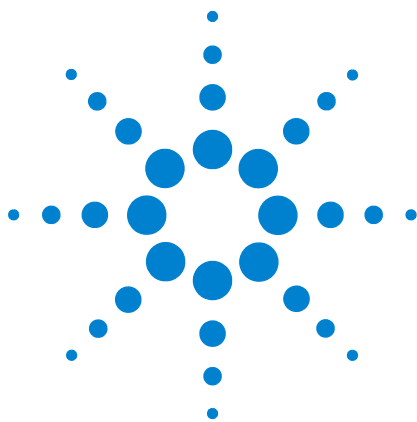

## 17 Maintaining the Aux EPC

Consumables and Parts for the Aux EPC	324
Installing or Replacing Frits in the Aux EPC	326

## Consumables and Parts for the Aux EPC

See the Agilent catalog for consumables and supplies for a more complete listing, or visit the Agilent Web site for the latest information ([www.agilent.com/chem/supplies](http://www.agilent.com/chem/supplies)).

**Table 49** Aux EPC consumables

Description	Part number
O-rings, package of 6	5181-3344
Blue dot frit, high flow resistance	G3430-80063
Red dot frit, medium flow resistance	G3430-80062
Brown dot frit, low flow resistance	G3430-80061
No frit (brass tube), zero flow resistance	G3430-20011

**Table 50** Auxiliary channel frits

Frit marking	Flow resistance	Flow characteristic	Often used with
Three rings Blue	High	$3.33 \pm 0.3$ SCCM @ 15 PSIG	NPD Hydrogen
Two rings Red	Medium	$30 \pm 1.5$ SCCM H <sub>2</sub> @ 15 PSIG	FID Hydrogen
One ring Brown	Low	$400 \pm 30$ SCCM AIR @ 40 PSIG	FID Air, QuickSwap, Purged splitters, Deans Switch

**Table 50** Auxiliary channel frits (continued)

Frit marking	Flow resistance	Flow characteristic	Often used with
None (brass tube) 	Zero	No restriction	Headspace vial pressurization, purged splitter and Deans Switch when using backflush

## Installing or Replacing Frits in the Aux EPC

To install or replace a frit in the Aux EPC block:

- 1 Gather the following:
  - T-10 Torx screwdriver
  - Appropriate O-ring and frit
  - Tweezers
- 2 Turn off the gas supply to the channel.
- 3 Select the appropriate frit. For information on selecting auxiliary channel frits, refer to the [7890 Series Advanced User Guide](#) and “Consumables and Parts for the Aux EPC”.
- 4 Loosen the captured screw for the channel that you want to change.
- 5 Lift up the pneumatic tubing block. Remove the frit and O-ring using the tweezers. Be careful to avoid scratching the metal surfaces.
- 6 Place a new O-ring on the new frit and press it down into the block.



- 7 Place the pneumatic tubing block on the new frit and tighten the captured screw firmly.
- 8 Restore the gas supply.

**WARNING**

**When hydrogen is used, dangerously high flows are possible if insufficient flow resistance is provided downstream of the supply tube. Always use either the High (Blue dot) or Medium (Red dot) frit with hydrogen.**

---

After installing or replacing a frit, be sure to update the PIDs used with your Aux EPC. For more information, refer to the [7890 Series Advanced User Guide](#).





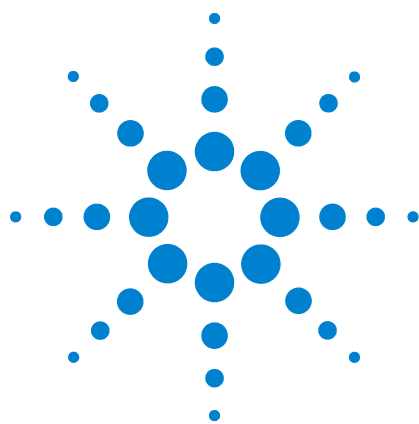

## 18 Maintaining the PCM

Consumables and Parts for the PCM 330

Calibrating the PCM Interface 331

Installing or Replacing Frits in the PCM 332

## Consumables and Parts for the PCM

See the Agilent catalog for consumables and supplies for a more complete listing, or visit the Agilent Web site for the latest information ([www.agilent.com/chem/supplies](http://www.agilent.com/chem/supplies)).

**Table 51** PCM consumables

Description	Part number
O-rings, package of 12	5180-4181
Proportional valve, Carrier	G3430-67013
Proportional valve, AUX	G3430-67016

## Calibrating the PCM Interface

The interface's flow module contains a pressure sensor that must be zeroed after it is installed on the GC. Calibration ensures an accurate interface pressure display.

Do not connect the carrier gas to the flow module until you have zeroed the interface's pressure sensor. For more information on zeroing the pressure sensor, refer to the [7890 Series Advanced User Guide](#).

- 1 If the gas supply is connected to the GC, turn off the supply at the source, then disconnect the supply line from the PCM inlet fitting.
- 2 Turn on the GC and wait 15 minutes to allow it to reach thermal equilibrium.
- 3 When the GC has reached thermal equilibrium, press **[Options]**, scroll to Calibration and press **[Enter]**.
- 4 Scroll to the module to be zeroed and press **[Enter]**.
- 5 Scroll to a zero line and press **[Info]**. The GC will remind you of the conditions necessary for zeroing that specific sensor.

Flow sensors. Verify that the gas is connected and flowing (turned on).

Pressure sensors. Disconnect the gas supply line at the back of the GC. Turning it off is not adequate; the valve may leak.

- 6 Press **[On/Yes]** to zero or **[Clear]** to cancel.
- 7 Turn off the GC.
- 8 Plumb the carrier gas to the flow module.
- 9 Turn on the GC.

If you were calibrating the flow sensor after replacing the PCM, check for leaks.

## Installing or Replacing Frits in the PCM

To install or replace a frit:

- 1 Gather the following:
  - O-rings, package of 12, 5180-4181
  - Restrictor
  - Tweezers
- 2 Turn off the gas supply to the channel.
- 3 Select the appropriate frit. For information on selecting PCM channel frits, refer to the [7890 Series Advanced User Guide](#).
- 4 Remove the screw holding the tubing block with the output tubing.
- 5 Remove the tubing block. Remove the frit and O-ring using the tweezers. Be careful to avoid scratching the metal surfaces.
- 6 Remove the other O-ring as well. Replace it with a new O-ring.

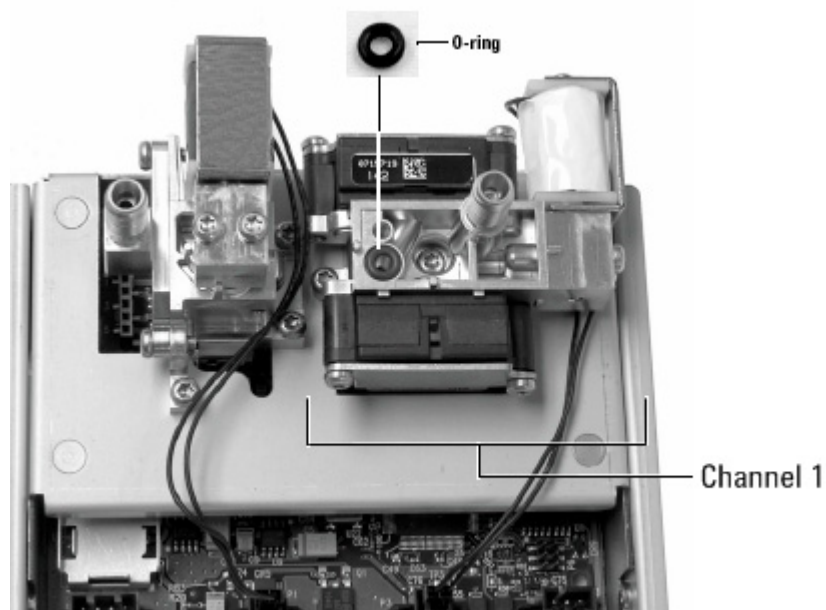

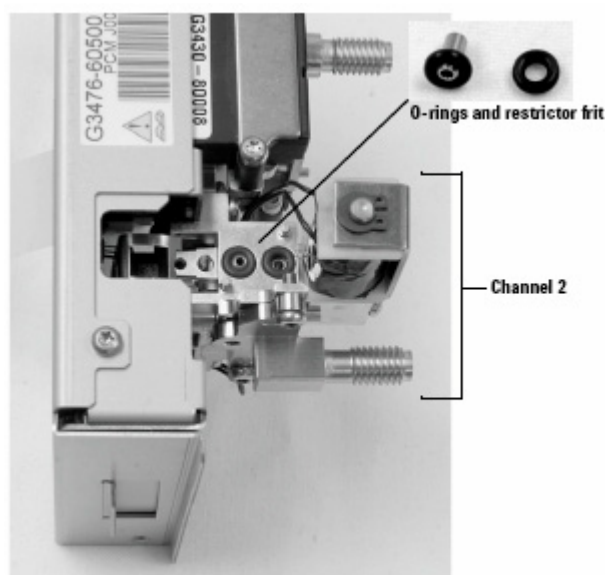

- 7 Place a new O-ring on the new frit and press it down into the block.
- 8 Place the block on the module and tighten the screw firmly.
- 9 Restore the gas supply.

**WARNING**

**When hydrogen is used, dangerously high flows are possible if insufficient flow resistance is provided downstream of the supply tube. Always use either the High (Blue dot) or Medium (Red dot) frit with hydrogen.**

After installing or replacing a frit, be sure to update the PIDs used with your PCM. For more information, refer to the [7890 Series Advanced User Guide](#).





## 19 Maintaining a Valve

- Consumables and Parts for Valves 336
- Exploded Parts View of GC Rotary Valves 337
- To Replace a Gas Sampling Valve Loop 338
- To Align a Rotary Valve Rotor 340
- To Replace a Rotary Valve in the Valve Box 341
- To Remove the Upper Valve Box 344
- To Install the Upper Valve Box 346



## Consumables and Parts for Valves

See the Agilent catalog for consumables and supplies for a more complete listing, or visit the Agilent Web site for the latest information ([www.agilent.com/chem/supplies](http://www.agilent.com/chem/supplies)).

**Table 52** Valve supplies

Description	Part number
<b>Valves, gas sampling</b>	
6-port, 300 psi	0101-0584
6-port, 400 psi, 225 °C maximum temperature	5062-9508
6-port, 300 °C maximum temperature	0101-0460
6-port Hastelloy, 400 psi, 225 °C maximum temperature	5062-9509
10-port, 400 psi, 225 °C maximum temperature	5062-9510
10-port Nitronic 60, 300 psi, 350 °C maximum temperature	0101-0585
10-port Hastelloy, 400 psi, 225 °C maximum temperature	5062-9511
<b>Valves, liquid sampling</b>	
0.2- $\mu$ L, 1000 psi, stainless steel, 175 °C maximum temperature	0101-0636
0.5- $\mu$ L, 5000 psi, 175 °C maximum temperature	0101-0639
0.5- $\mu$ L, 1000 psi, stainless steel, 175 °C maximum temperature	0101-0637
1.0- $\mu$ L, 1000 psi, stainless steel, 175 °C maximum temperature	0101-0638
<b>Gas sampling valve sample loops</b>	
0.25-cc	0101-0303
0.50-cc	0101-0282
1.00-cc	0101-0299
2.00-cc	0101-0300
2.0-mL nickel loop, 1/16-inch	0101-0955
5.00-cc	0101-0301
10.00-cc	0101-0302
Ferrule, 1/16 inch stainless steel (10/pk)	5181-1291
Nut, 1/16 inch (10/pk)	5181-1292



## Exploded Parts View of GC Rotary Valves

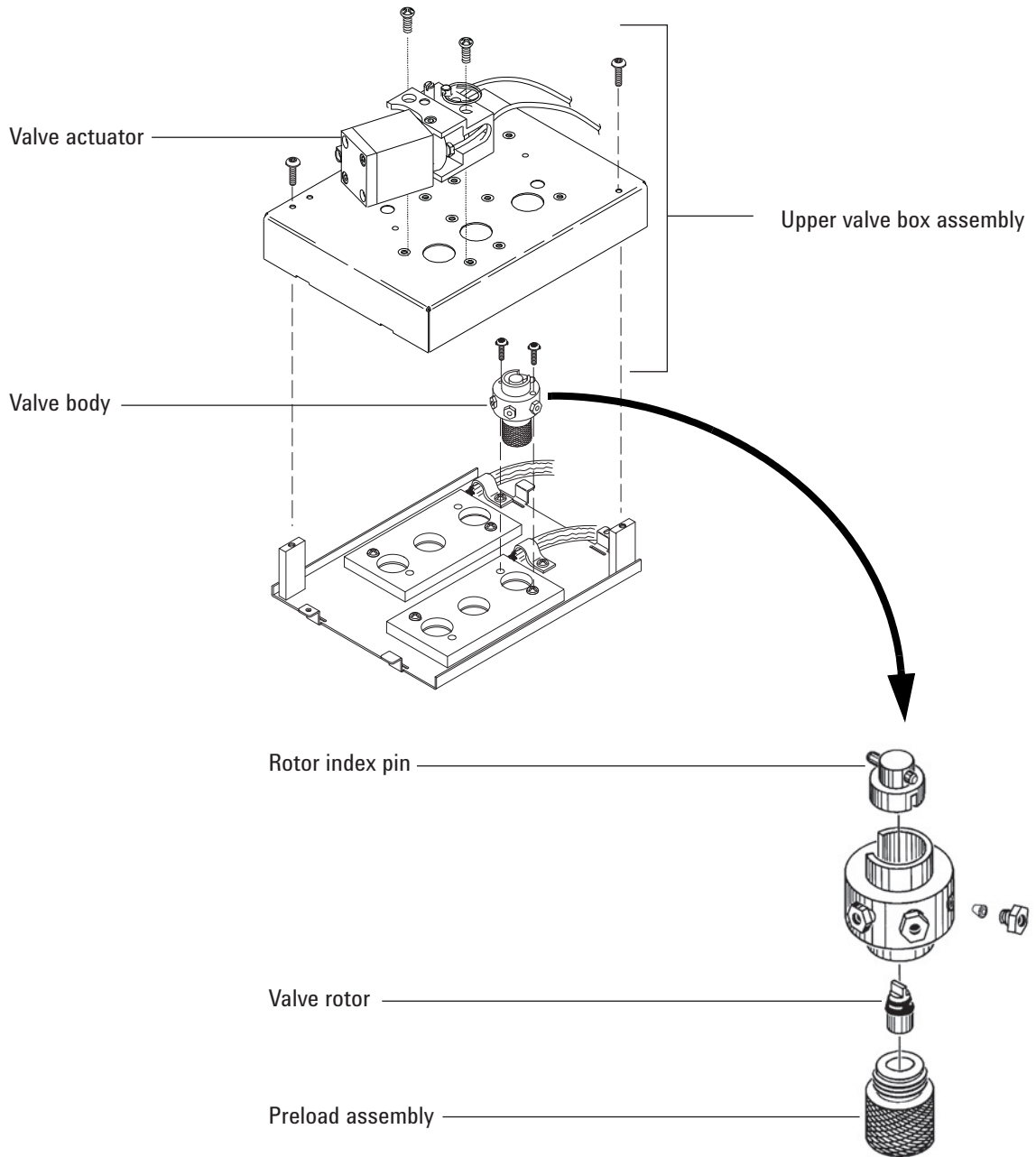

## To Replace a Gas Sampling Valve Loop

- 1 Gather the following:
  - Replacement sample loop. (See “Consumables and Parts for Valves” on page 336.)
  - 1/4-inch wrench
  - Vacuum cleaner
- 2 Load the [GC maintenance method](#) and wait for the GC to become ready.
- 3 Turn off the detector.

### WARNING

The oven, inlet, detector, and valve box may be very hot.

Sample and/or harmful gases may be present. Refer to your company's standard operating procedures for purging the chemicals from the sample line.

---

- 4 Set all valve box valves to **Off**.
- 5 Leave on the GC and valve actuator air.
- 6 Turn off the carrier gas and sample line flows and relieve any back pressure to the valve.

### WARNING

The valve box insulation is made of refractory ceramic fibers (RCFs). To avoid inhaling RCF particles, we recommend these safety procedures:

1. Ventilate your work area
  2. Wear long sleeves, gloves, safety glasses, and a disposable dust/mist respirator
  3. Dispose of insulation in a sealed plastic bag
  4. Vacuum any residual particles and discard
  5. Wash your hands with mild soap and cold water after handling RCFs.
- 

- 7 Remove the upper valve box. (See “To Remove the Upper Valve Box” on page 344.)
- 8 Vacuum any loose particulate insulation.
- 9 When the valve is cool, loosen the sample loop's two 1/4-inch fittings on the valve head and remove the loop.

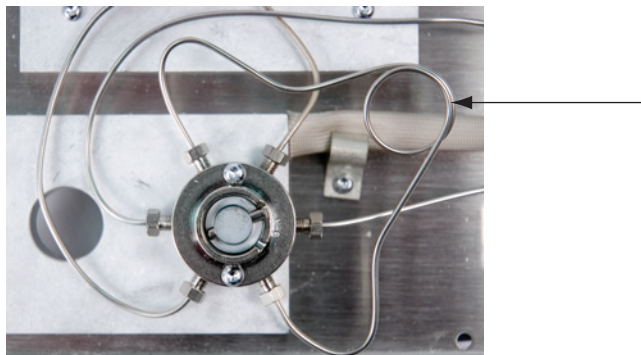

- 10 Install the new sample loop.
- 11 Repressurize the sample loop and check for leaks.
- 12 Install the upper valve box. (See [“To Install the Upper Valve Box”](#) on page 346.)
- 13 Restore the analytical method.

## To Align a Rotary Valve Rotor

- 1 Gather the following:
  - Flathead screwdriver
  - 3-mm hex key wrench
  - T-20 Torx screwdriver
- 2 Set the oven and valve box heated zones to a safe handling temperature (25 °C).
- 3 Set all valves to **Off**.

**WARNING**

**The oven, inlet, detector, and valve box may be very hot. If they are hot, wear heat-resistant gloves to protect your hands.**

---

- 4 Loosen the adjustment set screw.

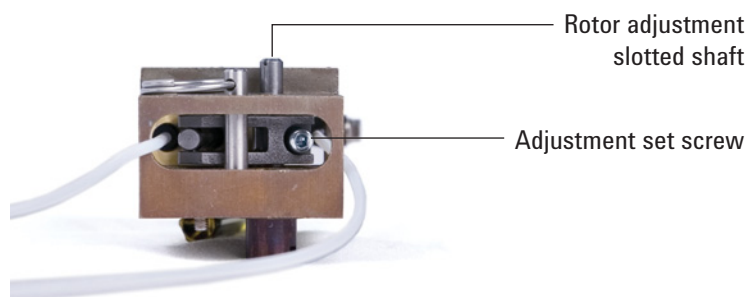

- 5 Locate the rotor adjustment shaft on top of the actuator. Using a flathead screwdriver, rotate the valve rotor counterclockwise until it stops, then back it off a small amount to set one end of the rotor's motion (< 1 mm).
- 6 Tighten the adjustment set screw.
- 7 Turn the valve **On**, turn **Off** to check for smooth operation.
- 8 Restore the analytical method.

## To Replace a Rotary Valve in the Valve Box

**WARNING**

Do not install a liquid sampling valve (LSV) in the valve box if you plan to heat the box above 75 °C. Heating an LSV over 75 °C can cause a leak and subsequent explosion. LSVs should be mounted in the side location to avoid potential explosions.

---

- 1 Gather the following:
  - Replacement valve (See “Consumables and Parts for Valves” on page 336.)
  - T-10 Torx screwdriver
  - 1/4-inch wrench
  - Needle-nosed pliers
  - Vacuum
- 2 Load the [GC maintenance method](#) and wait for the GC to become ready.

**WARNING**

**The oven, inlet, detector, and valve box may be very hot.**

**Sample and/or harmful gases may be present. Refer to your company’s standard operating procedures for purging the chemicals from the sample line.**

---

- 3 Set all valves to **Off**.
- 4 Leave on the GC and valve actuator air.
- 5 Turn off the carrier gas and sample line flows and relieve any back pressure to the valve.

**WARNING**

The valve box insulation is made of refractory ceramic fibers (RCFs). To avoid inhaling RCF particles, we recommend these safety procedures:

1. Ventilate your work area
2. Wear long sleeves, gloves, safety glasses, and a disposable dust/mist respirator
3. Dispose of insulation in a sealed plastic bag
4. Vacuum any residual particles and discard
5. Wash your hands with mild soap and cold water after handling RCFs.

- 6 Remove the upper valve box. (See “To Remove the Upper Valve Box” on page 344.) Vacuum any RCF insulation particulates from the valve box area.
- 7 Note the tubing connections to the existing valve and label if desired.
- 8 Disconnect the existing valve fittings.
- 9 Remove the two T-10 Torx screws attaching the valve to the valve box, then remove the valve from the valve box.
- 10 Place the new valve in the valve box. The gap in the index ring on top of a 6-port valve points toward the back of the GC if installed correctly. This is the **On** position. Install and tighten the two screws with a screwdriver.

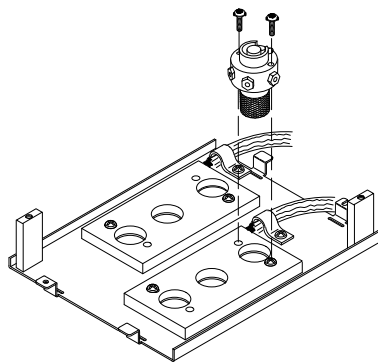

- 11 Use needle-nosed pliers to move the valve rotor index pin of the valve counterclockwise until the pin touches the valve stop **Off** position.

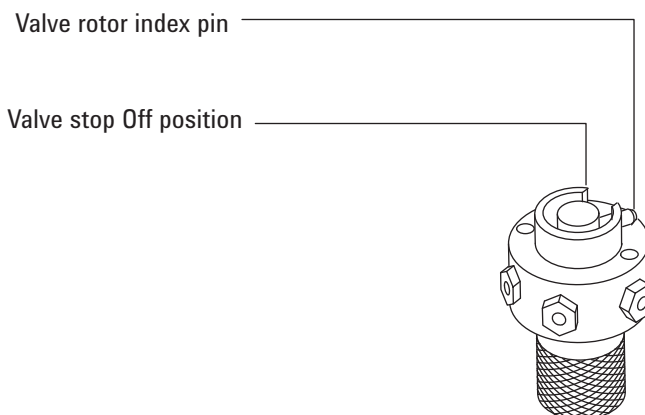

12 Plumb the new valve using the existing fittings.

**WARNING**

**Hazardous sample gases may be present.**

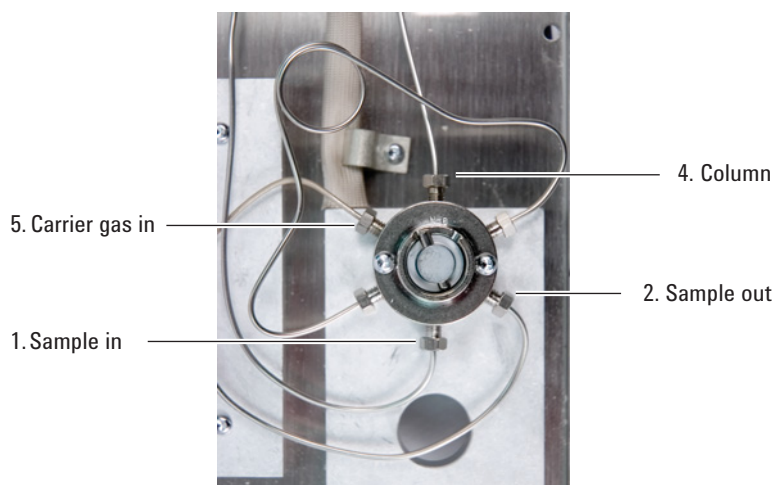

13 Turn on the carrier and sample gases, then check for leaks at the valve fittings.

- Using the needle-nosed pliers to toggle the valve, check both the **On** and **Off** positions.
- When leak free, set the valve to **Off** (see [step 11](#)).

14 Install the upper valve box assembly. (See [“To Install the Upper Valve Box”](#) on page 346.)

15 Restore the analytical method.

16 Reset the valve EMF counters. See [To Reset an EMF Counter](#) in the *Operation Manual*.

## To Remove the Upper Valve Box

- 1 Gather a T-20 Torx screwdriver.
- 2 Set the valve box to a safe handling temperature (25 °C), or load the [GC maintenance method](#).

**WARNING**

**The oven, inlet, detector, and valve box may be very hot. If they are hot, wear heat-resistant gloves to protect your hands.**

---

- 3 Lift and remove the detector cover.
- 4 Remove the mounting screws from the upper valve box.

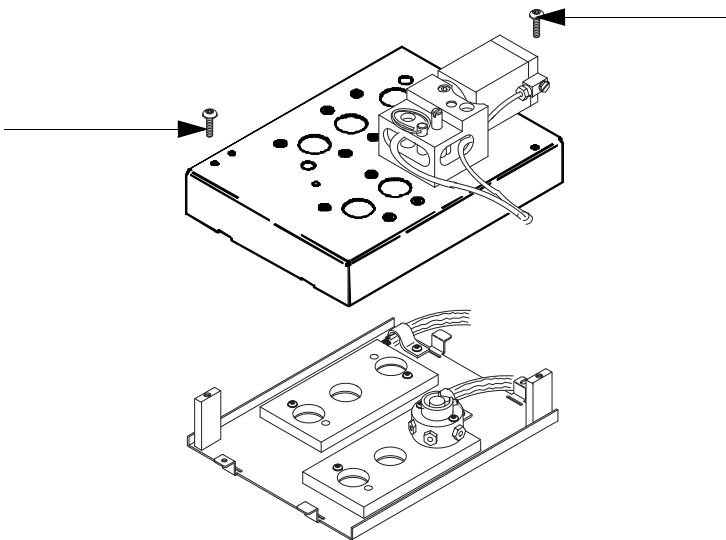

- 5 Lift up and set aside.



**WARNING**

The valve box insulation is made of refractory ceramic fibers (RCFs). To avoid inhaling RCF particles, we recommend these safety procedures:

1. Ventilate your work area
  2. Wear long sleeves, gloves, safety glasses, and a disposable dust/mist respirator
  3. Dispose of insulation in a sealed plastic bag
  4. Vacuum any residual particles and discard
  5. Wash your hands with mild soap and cold water after handling RCFs.
-

## To Install the Upper Valve Box

- 1 Gather the following:
  - T-20 Torx screwdriver
  - 3-mm hex key wrench
  - Flathead screwdriver
- 2 Verify that all valve rotors are in the full counterclockwise position (valve **Off**).
- 3 For each actuator that mates with a newly installed valve:
  - a Loosen the adjustment set screw.

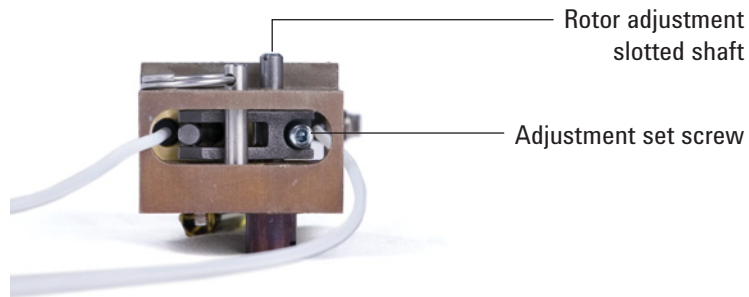

- b Locate the rotor adjustment shaft on top of the actuator. Use a screwdriver to rotate the valve rotor counterclockwise until it stops.

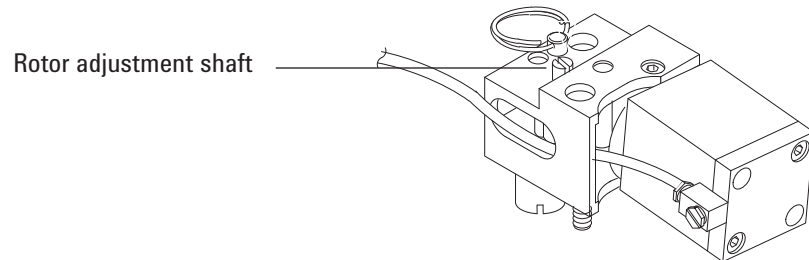

- 4 Locate the two half-moon cutouts at the bottom back of the upper valve box. Place the upper valve box on top of the lower valve assembly, routing the heater/sensor wires through the cutouts. Secure with two T-20 mounting screws.
- 5 Push each coupling/shaft assembly downward with a flathead screwdriver until the slot on the coupling engages the rotor index pin.

If the coupling and valve do not engage, check that both are fully counterclockwise and try again. If necessary, turn the shaft slightly to engage the coupling.

- 6 For each newly installed valve:
  - a Using a flathead screwdriver, turn the rotor adjustment shaft counterclockwise until it stops, then back it off a small amount ( $< 1$  mm) to set one end of the rotor's motion.
  - b Tighten the adjustment set screw.
- 7 Install the detector cover.
- 8 Restore normal operating condition.

## 19 Maintaining a Valve



## A Swagelok Connections

Making Swagelok Connections 350

Using a Swagelok Tee 354

The gas supply tubing is attached with Swagelok fittings. If you are not familiar with Swagelok connections, review the following procedures.



## Making Swagelok Connections

### Objective

To make a tubing connection that does not leak and that can be taken apart without damaging the fitting

### Materials needed:

- 1/8-inch (or 1/4-inch, if used) preconditioned copper tubing
- 1/8-inch (or 1/4-inch, if used) Swagelok nuts
- Front and back ferrules
- Two 7/16-inch (for 1/8-inch nuts) or 9/16-inch (for 1/4-inch nuts) wrenches

- 1 Place a Swagelok nut, back ferrule, and front ferrule to the tubing as shown in [Figure 9](#).

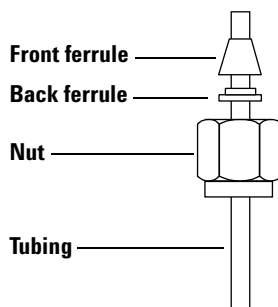

**IMPORTANT!**  
The narrow end of the back ferrule fits into the rear of the front ferrule.

**Figure 9** Swagelok nuts and ferrules

- 2 Clamp a stainless steel plug or similar fitting in a bench vise.

### CAUTION

Use a separate stainless steel fitting in a vise for initial tightening of the nut. Do not use an inlet or detector fitting. Strong forces are required to properly set the ferrules, and damage to an inlet or detector fitting is very costly to repair.

- 3 Push the tubing into the stainless steel plug ([Figure 10](#)).
- 4 Make sure that the front ferrule is touching the plug. Slide the Swagelok nut over the ferrule and thread it onto the plug.

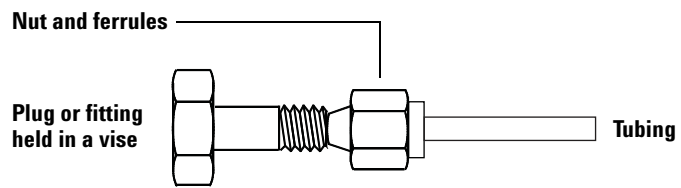

**Figure 10** Assembling the fitting

- 5 Push the tube fully into the plug, then withdraw it approximately 1 to 2 mm ([Figure 11](#)).

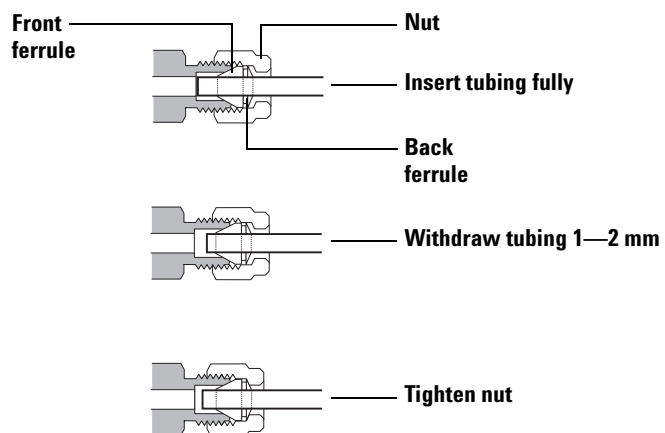

**Figure 11** Insert the tubing

- 6 Finger-tighten the nut.
- 7 Mark the nut with a pencil line ([Figure 12](#)).

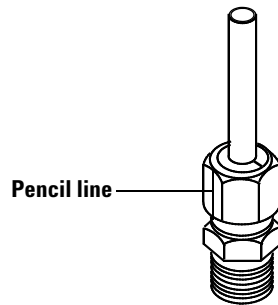

**Figure 12** Marking the fitting

- 8** For 1/8-inch Swagelok fittings, use a pair of 7/16-inch wrenches to tighten the fitting 3/4 of a turn (Figure 13). For 1/4-inch fittings, use a pair of 9/16-inch wrenches to tighten them 1-1/4 turn (Figure 13).

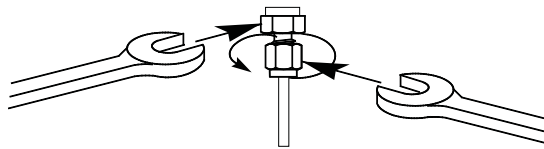

**Figure 13** Final tightening

- 9** Remove the plug from the fitting. To connect the tubing, with nut and ferrules, to another fitting, finger-tighten the nut, then use a wrench to tighten it 3/4 (1/8-inch fittings) or 1-1/4 (1/4-inch fittings) of a turn.
- 10** Both correctly- and incorrectly-swaged connections are shown in Figure 14. Note that the end of the tubing in a correctly-swaged fitting is not crushed and does not interfere with the action of the ferrules.



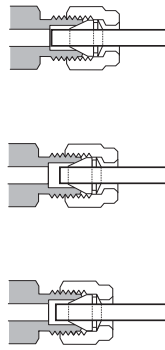

**Figure 14** Completed fitting

## Using a Swagelok Tee

To supply gas from a single source to more than one input, use a Swagelok Tee.

**NOTE**

Do not combine valve actuator air with flame ionization air. The valve action will cause major upsets in the detector signal.

**Materials needed:**

- 1/8-inch preconditioned copper tubing
  - Tubing cutter
  - 1/8-inch Swagelok nuts and front and back ferrules
  - 1/8-inch Swagelok Tee
  - Two 7/16-inch wrenches
  - 1/8-inch Swagelok cap (optional)
- 1 Cut the tubing where you want to install the Tee. Connect the tubing and Tee with a Swagelok fitting. See [Figure 15](#).

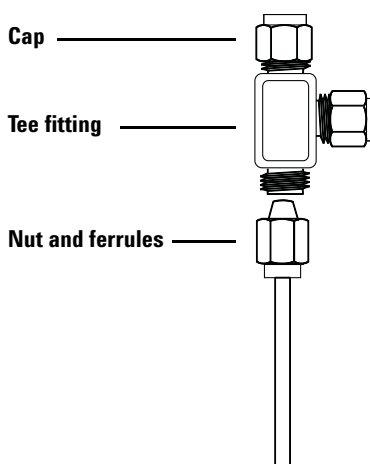

**Figure 15** Swagelok tee

- 2 Measure the distance from the Tee to the GC inlets. Attach copper tubing to the open Tee ends with Swagelok fittings.