

HGST CinemaStar™ Z5K500.B

HCC545050B7E360



Revision 1.0 (November 18, 2016)

Revision 1.1 (August 10, 2017)

One MB is equal to one million bytes, one GB is equal to one billion bytes and one TB equals 1,000GB (one trillion bytes) when referring to storage capacity. Accessible capacity will vary from the stated capacity due to formatting and partitioning of the drive, the computer's operating system, and other factors.

The following paragraph does not apply to any jurisdiction where such provisions are inconsistent with local law: THIS PUBLICATION IS PROVIDED "AS IS" WITHOUT WARRANTY OF ANY KIND, EITHER EXPRESS OR IMPLIED, INCLUDING, BUT NOT LIMITED TO, THE IMPLIED WARRANTIES OF MERCHANTABILITY OR FITNESS FOR A PARTICULAR PURPOSE.

This publication could include technical inaccuracies or typographical errors. Changes are periodically made to the information herein; these changes will be incorporated in new editions of the publication. There may be improvements or changes in any products or programs described in this publication at any time. It is possible that this publication may contain reference to, or information about, HGST products (machines and programs), programming, or services that are not announced in your country. Such references or information must not be construed to mean that Western Digital Corporation intends to announce such HGST products, programming, or services in your country. Technical information about this product is available by contacting your local HGST product representative or on the Internet at: support.hgst.com.

Western Digital Corporation may have patents or pending patent applications covering subject matter in this document. The furnishing of this document does not give you any license to these patents.

© 2017 Western Digital Corporation or its affiliates.

Western Digital, the HGST logo, CacheFlow, CinemaStar, Data Lifeguard and SilkStream logo are registered trademarks or trade-marks of Western Digital Corporation or its affiliates in the U.S. and/or other countries. All other trademarks are the property of their respective owners.

References in this publication to HGST-branded products, programs, or services do not imply that they will be made available in all countries. Product specifications provided are sample specifications and do not constitute a warranty. Actual specifications for unique part numbers may vary. Please visit the Support section of our website, support.hgst.com, for additional information on product specifications. Pictures shown may vary from actual products.

HGST CinemaStar Z5K500.B

Technical Reference Manual

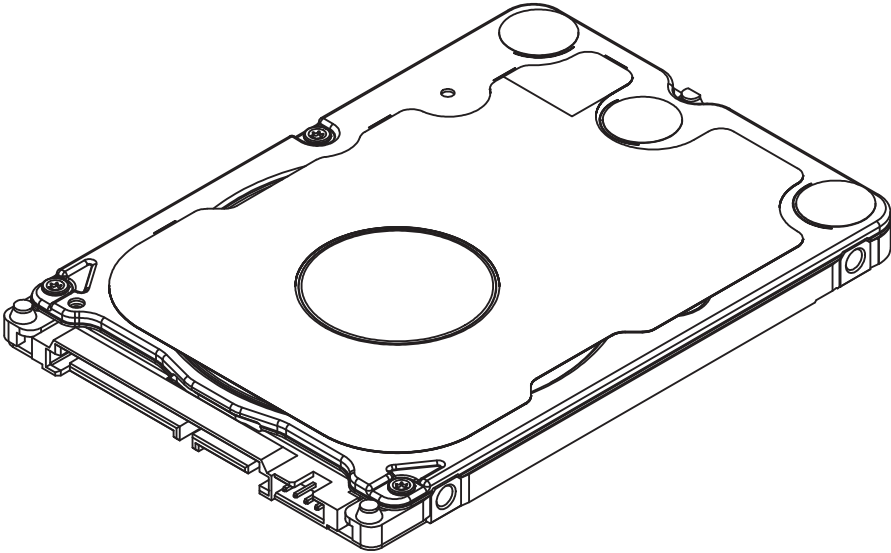

TABLE OF CONTENTS

1. DESCRIPTION AND FEATURES	9
1.1 General Description.....	9
1.2 Product Features	9
2. SPECIFICATIONS.....	11
2.1 Performance Specifications.....	11
2.2 Physical Specifications.....	12
2.2.1 Physical Dimensions.....	12
2.3 Mechanical Specifications.....	13
2.4 Electrical Specifications.....	14
2.4.1 Current Requirements and Power Dissipation.....	14
2.4.2 Input Voltage Requirements	14
2.4.3 Ripple.....	14
2.4.4 ESD.....	14
2.5 Environmental Specifications	15
2.5.1 Shock and Vibration	15
2.5.2 Temperature and Humidity	16
2.5.3 Thermocouple Location	16
2.5.4 Cooling.....	17
2.5.5 Atmospheric Pressure	17
2.5.6 Acoustics.....	17
2.5.7 RoHS (Restriction of Hazardous Substances)	17
2.6 Reliability Specification and Characteristics	18
2.6.1 Average AFR Spectrum.....	18
2.7 Device Plug Connector Pin Definitions	19
2.8 Agency Approvals.....	20
2.9 Full Model Number Specification.....	20
3. PRODUCT FEATURES.....	21
3.1 SATA 3 Gb/s	22
3.2 ATA-8 Streaming.....	22
3.3 SilkStream	22
3.4 Advanced Format Technology	22
3.5 Perpendicular Magnetic Recording (PMR).....	23
3.6 Reduced Power Spinup (RPS).....	23
3.7 System-on-Chip (SOC)	23
3.8 S.M.A.R.T. Command Transport (SCT).....	23
3.8.1 Write Same.....	24
3.8.2 Temperature Reporting	24
3.9 Reliability Features Set	24
3.9.1 Data Lifeguard™	24
3.9.2 Thermal Management.....	25
3.9.3 Internal Environmental Protection System	25
3.9.4 Recoverable Errors.....	25
3.9.5 Unrecoverable Errors.....	25
3.9.6 Self Test	25
3.9.7 ATA Error Logging	26
3.9.8 Defect Management.....	26
3.10 Automatic Defect Retirement.....	26
3.10.1 Error Recovery Process.....	26
3.11 Hot Plug Support	27
3.12 Active LED Status.....	27
3.13 Fluid Dynamic Bearings (FDB)	27
3.14 Staggered Spinup and Activity Indication (SATA Power Pin 11).....	27
3.14.1 Staggered Spinup	27
3.14.2 Activity Indication	28
3.15 CacheFlow™.....	28

3.15.1	Write Cache	28
3.15.2	Read Cache	28
3.15.3	48-bit Logical Block Addressing (LBA)	29
3.16	Power Management	29
3.17	Self-Monitoring, Analysis, and Reporting Technology (S.M.A.R.T.)	29
3.18	Security Mode	29
3.18.1	Master and User Passwords	29
3.18.2	Security Levels	30
4.	ATA COMMAND SET	31
4.1	Host Interface Commands	31
4.1.1	ACS3 Commands	31
4.1.2	Download MicroCode -92h	32
4.1.3	Obsolete Commands	32
4.1.4	SCT Commands	33
4.2	S.M.A.R.T. (B0h)	33
4.2.1	Read Attribute Values Sub-Command	33
4.2.2	Supported Attributes	35
4.2.3	Read Log Sector	36
4.3	Identify Device (ECh)	37
4.4	Set Features (EFh)	48
5.	INSTALLATION AND SETUP PROCEDURES	49
5.1	Unpacking	49
5.1.1	Handling Precautions	49
5.1.2	Inspection of Shipping Container	50
5.1.3	Removal From Shipping Container	50
5.1.4	Removal From Static Shielding Bag	50
5.1.5	Moving Precautions	51
5.2	Mounting Restrictions	51
5.2.1	Orientation	51
5.2.2	Screw Size Limitations	51
5.2.3	Grounding	51
5.3	Jumper Settings	52
6.	MAINTENANCE	54
7.	GLOSSARY	55

LIST OF FIGURES

Figure 2-1 Mounting Dimensions	13
Figure 2-2 Drive Base Casting Thermocouple Location	16
Figure 2-3 Forced Airflow Direction	17
Figure 2-4 Average AFR Spectrum	18
Figure 2-5 Standard Factory Connectors	19
Figure 5-1 Drive Handling Precautions	49
Figure 5-2 Hard Drive Removal From Static Shielding Bag.....	50
Figure 5-3 Grounding Diagram.....	51
Figure 5-4 Jumper Settings	53

LIST OF TABLES

Table 2-1 Shock and Vibration	15
Table 2-2 Device Pin Connector Pin Definitions.....	19
Table 2-3 Full Model Number Description.....	20
Table 4-1 ACS3 Command Opcodes.....	31
Table 4-2 Download Microcode Subcommand field.....	32
Table 4-3 Obsolete Command Opcodes	32
Table 4-4 SCT Action Codes.....	33
Table 4-5 Definitions for the 512 Bytes.....	33
Table 4-6 Log Address Definition	36
Table 4-7 Identify Device Command.....	37

1.0 DESCRIPTION AND FEATURES

1.1 General Description

HGST CinemaStar SATA hard drives are specially engineered to offer cool quiet operation while providing maximum reliability in 24x7 always-on environments. With support for multiple simultaneous HD video streams, these drives are perfect for DVRs, set-top boxes and digital video surveillance.

HGST's rugged and reliable hard drives are designed and manufactured to the highest standards of quality and reliability. Built to last, this SATA hard drive is made for years of cool-running, high-performance operation around the clock. Before shipping, every drive undergoes over 200 rigorous tests to ensure functionality and compatibility.

1.2 Product Features

- **Serial ATA (SATA)** — Serial ATA (SATA) is the next generation bus interface for 2.5-inch hard drives. It is designed to replace Parallel ATA, and has many advantages including increased transfer rate, improved signal integrity, enhanced data protection, and hot plug support.
- **ATA-8 Streaming Commands**— The industry standard ATA-8 streaming command set enhances streaming performance in personal video recorders and other CE devices. HGST drives compatible with ATA-8 streaming commands can handle multiple data streams without degradation in video quality, and are optimal for AV storage applications.
- **SilkStream™**— Optimized for smooth, continuous digital video playback of up to twelve simultaneous HD streams. SilkStream is compatible with the ATA streaming command set so CE customers can use standard streaming management and error recovery options.
- **Dynamic Fly Height Control** — Designed to compensate for head/media separation changes due to temperature and altitude. This feature adds video quality margins across temperature and altitude changes.
- **Advanced Format Technology** — Technology adopted by HGST and other drive manufacturers to increase media format efficiencies, thus enabling larger drive capacities.
- **Perpendicular Magnetic Recording (PMR)** — With PMR technology the magnetization of each data bit is aligned vertically to the spinning disk, rather than longitudinally as has been the case in hard drive technology for decades. This enables more data on a given disk than is possible with conventional longitudinal recording, and provides a platform for future expansion of hard drive densities.
- **Reduced Power Spinup (RPS)** — This optimized start up feature specifically designed for the external hard drive and Consumer Electronics (CE) market. Specific focus for RPS is to minimize the duration and magnitude of the peak power consumption from the hard drive.
- **System-on-Chip** - The System-on-Chip (SOC) is the foundation for HGST's next generation electronics and firmware architecture. The native SATA SOC lowers component count by integrating a hard disk controller, high performance processor, high speed execution SRAM, and read channel in a 128-pin package.
- **S.M.A.R.T. Command Transport (SCT)** — The SCT Command Transport feature set provides a method for a host to send commands and data to a device and for a device to send data and status to a host using log pages.

- **Reliability Features Set-Data Lifeguard™** — Representing HGST's ongoing commitment to data protection, Data Lifeguard includes features that enhance the drive's ability to prevent data loss. Data Lifeguard data protection utilities include thermal management, an environmental protection system, and embedded error detection and repair features that automatically detect, isolate, and repair problem areas that may develop over the extended use of the hard drive. With these enhanced data reliability features, the drive can perform more accurate monitoring, error repair, and deliver exceptional data security.
- **Hot Plug Support** — SATA supports hot plugging (also known as “hot swapping”), the ability to swap out a failed hard drive without having to power down the system or reboot. This capability contributes to both data availability and serviceability without any associated downtime, making it a critical feature for extending SATA into enterprise applications.
- **Active LED Status** — These drives support external LED requirements. It provides an activity LED output which is ON during command execution and OFF otherwise.
- **Fluid Dynamic Bearings (FDB)** — Bearing design that incorporates a layer of high-viscosity lubricant instead of ball bearings in the hard drive spindle motor. As an alternative to conventional ball bearing technology, FDB designs provide increased non-operational shock resistance, speed control, and improved acoustics.
- **Staggered Spin-Up** — Native SATA feature that allows the system to control whether the drive will spin up immediately or wait until the interface is fully ready.
- **CacheFlow™** — This unique, multi-generation caching algorithm evaluates the way data is read from and written to the drive and adapts “on-the-fly” to the optimum read and write caching methods. CacheFlow minimizes disk seek operations and overheads due to rotational latency. CacheFlow supports sequential and random write cache. With write cache and other CacheFlow features, the user can cache both read and write data. The cache can hold multiple writes and collectively write them to the hard drive.
- **48-bit Logical Block Addressing (LBA)** — The drives support both 48-bit and 28-bit LBA and CHS-based addressing. LBA is included in advanced BIOS and operating system device drivers and ensures high capacity disk integration.
- **Power Management** — The drives support the ATA and Serial ATA power management command set, allowing the host to reduce the power consumption of the drive by issuing a variety of power management commands.
- **Automatic Defect Retirement** — If the drive detects a defective sector while reading, writing, or performing offline data collection, it automatically relocates the sector without end-user intervention.
- **Self-Monitoring, Analysis, and Reporting Technology (S.M.A.R.T.)** — S.M.A.R.T. enables a drive's internal status to be monitored through diagnostic commands at the host level and during offline activities. S.M.A.R.T. devices employ data analysis algorithms that are used to predict the likelihood of some near-term degradation or fault conditions. When used with a S.M.A.R.T. application, the drive can alert the host system of a negative reliability status condition. The host system can then warn the user of the impending risk of data loss and recommend an appropriate action.
- **ATA Security** — The drives support the ATA Security Mode Feature set. The ATA Security Mode feature set allows the user to create a device lock password that prevents unauthorized hard disk access even if the drive is removed from the host computer. The correct password must be supplied to the hard drive in order to access user data. Both the User and Master Password features are supported, along with the High and Maximum security modes. The Master Password Revision code is also supported.

2.0 SPECIFICATIONS

2.1 Performance Specifications

Average Seek ¹ - Read - Write	11.0 ms average 12.0 ms average
Full Stroke Seek	21 ms average
Index Pulse Period	11.1 ms (nominal)
Average Latency	5.5 ms
Rotational Speed	5400 RPM
Data Transfer Rate (maximum) ² - Buffer to Host - Max buffer to disk	3 Gb/s 147 MB/s maximum
Buffer Size	16MB
Error Rate - Unrecoverable	<1 in 10 ¹⁴ bits read
Spindle Start Time - From Power-on to Drive Ready ³ - From Power-on to Rotational Speed ⁴	<3.5s average 2.0s average
Spindle Stop Time	8s average
Load/Unload Cycles ⁵	600,000

¹ During continuous Seek, Read, or Write commands, an algorithm in the code will add latency as required to keep the VCM motor from overheating. Seek performance will be impacted under this condition.

² As used for storage capacity, one megabyte (MB) = one million bytes, one gigabyte (GB) = one billion bytes, and one terabyte (TB) = one trillion bytes. Total accessible capacity varies depending on operating environment. As used for buffer or cache, one megabyte (MB) = 1,048,576 bytes. As used for transfer rate or interface, megabyte per second (MB/s) = one million bytes per second, and gigabit per second (Gb/s) = one billion bits per second. Effective maximum SATA 3 Gb/s transfer rate calculated according to the Serial ATA specification published by the SATA-IO organization as of the date of this specification sheet. Visit www.sata-io.org for details.

³ Defined as the time from power-on to the setting of Drive Ready and Seek Complete including calibration.

⁴ Defined as the time from power-on to when the full spindle rotational speed is reached.

⁵ Controlled unload at ambient condition.

2.2 Physical Specifications

Physical Specifications	HCC545050B7E360
Capacity ¹	500,107MB
Interface	SATA 3 Gb/s
Number of Disks	1
Data Surfaces	2
Number of Heads	2
Physical bytes per sector	4096
Host bytes per sector	512
User Sectors per Drive	976,773,168
Recording Method	LDPC Target
¹ As used for storage capacity, one megabyte (MB) = one million bytes, one gigabyte (GB) = one billion bytes, and one terabyte (TB) = one trillion bytes. Total accessible capacity varies depending on operating environment. As used for buffer or cache, one megabyte (MB) = 1,048,576 bytes. As used for transfer rate or interface, megabyte per second (MB/s) = one million bytes per second, and gigabit per second (Gb/s) = one billion bits per second. Effective maximum SATA 3 Gb/s transfer rate calculated according to the Serial ATA specification published by the SATA-IO organization as of the date of this specification sheet. Visit www.sata-io.org for details.	

2.2.1 Physical Dimensions

	English		Metric	
	Dimension	Tolerance	Dimension	Tolerance
Height	0.27 inches	±0.01 inch	6.8 mm	±0.20 mm
Length	3.94 inches	±0.01 inch	100.20 mm	±0.25 mm
Width	2.75 inches	±0.01 inch	69.85 mm	±0.25 mm
Weight (typical)	0.20 pounds	—	92 g	—

2.3 Mechanical Specifications

Figure 2-1 shows the mounting dimensions and locations of the screw holes for the drive.

Figure 2-1. Mounting Dimensions

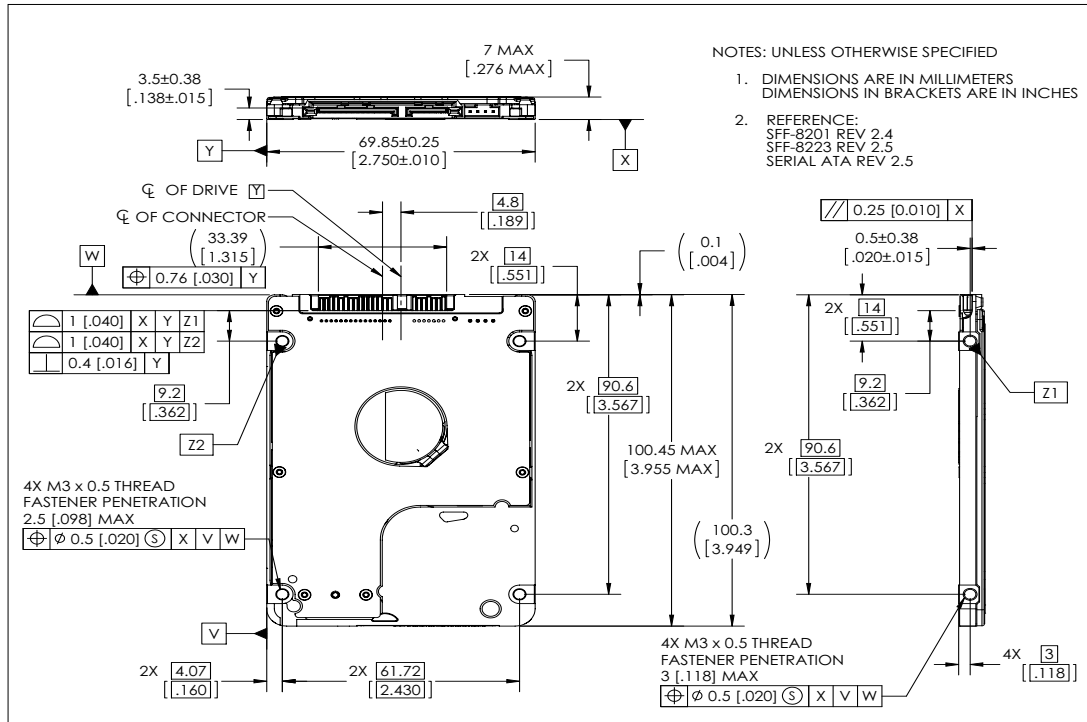

2.4 Electrical Specifications

2.4.1 Current Requirements and Power Dissipation

Operating Mode	Current ¹	Power ¹
	5 VDC	
Spinup (max)	985 mA	4.9W
Read/Write (average)	320 mA	1.65W
Seek (average)	359 mA	1.8W

POWER MANAGEMENT COMMANDS		
Operating Mode	Current ¹	Power ¹
	5 VDC	
Idle (E1H)(average)	259 mA	1.29W
Standby (E0H)(average)	31 mA	0.16W
Sleep (E6H)(average)	31 mA	0.16W

¹ All values are typical (25°C and 5V input) except where specified as maximum.

2.4.2 Input Voltage Requirements

The input voltage requirement for these drives is +5.0V ± 5%.

2.4.3 Ripple

	+5 VDC
Maximum Frequency	100 mV (peak-to-peak) 10 KHz - 30 MHz

2.4.4 ESD

The ESD specification compliance is determined at room ambient conditions with nominal power supply settings, unless otherwise specified.

Op-System Level	Minimum
Direct contact discharges	8 kV
Direct air discharges	15 kV
Indirect contact discharges (VCP & HCP)	8 kV
Indirect air discharges (VCP & HCP)	15 kV
Non-Op Drive Level	
Direct contact discharges	8 kV
Direct air discharges	15 kV

2.5 Environmental Specifications

2.5.1 Shock and Vibration

Table 2-1. Shock and Vibration

Shock	
Operating (2 ms)	400G
Non-operating (2 ms)	1000G
<i>Note: Half-sine wave, measured without shock isolation and without non-recoverable errors.</i>	
Vibration	
Operating ¹	0.063g ² /Hz, 5 Hz-40 Hz; 0.063g ² /Hz-0.0006g ² /Hz, 40 Hz-500 Hz
Non-operating ²	0.06984 g ² /Hz, 10-500 Hz
Drive Generated Vibration	
Operating (average)	0.22 gm-mm
Rotational Shock Non-Operating	
Amplitude	50K rad/sec ²
Duration	2 ms

¹ 2.2 G_{rms}, measured using random write/read ratio of 1:3 at block size of 256.
² 5.8 G_{rms}.

Operating Vibration

Drives are tested by applying a random or swept sinusoidal excitation in each linear axis, one axis at a time. The drive incurs no physical damage and no hard errors while operating and subjected to continuous vibration not exceeding the level listed in Table 2-1. Operating performance may degrade during periods of exposure to continuous vibration.

Non-Operating Vibration

Note: This specification applies to handling and transportation of unmounted drives.

Drives are tested by applying a random or swept sinusoidal excitation in each linear axis, one axis at a time. The drive incurs no physical damage when subjected to continuous vibration not exceeding the level listed in Table 2-1.

Drive Generated Vibration

Drives are tested by supporting a single drive horizontally in a free-free state and measuring the side-to-side vibration. Self vibration may not exceed the level listed in Table 2-1.

Rotational Shock Non-Operating

Drives are tested by applying a rotational force centered around the actuator pivot. The drive incurs no physical damage when subjected to the rotational force specified in Table 2-1.

Packaged Shock and Vibration

The shipping packaging is designed to meet the National/International Safe Transit Association (N/ISTA) standards for packaged products. The drive incurs no physical damage when subjected to the N/ISTA standards.

2.5.2 Temperature and Humidity

Operation	
Min-Max Base Casting Temperature ¹	0°C to 65°C (32°F to 149°F)
Humidity	8-90% RH non-condensing 29.4°C (maximum wet bulb)
Thermal Gradient	20°C/hour (maximum)
Humidity Gradient	20%/hour (maximum)
Non-Operation	
Non-operating Temperature	-40°C to 70°C (-40°F to 158°F)
Humidity	5-95% RH non-condensing 40°C (maximum wet bulb)
Thermal Gradient	30°C/hour (maximum)
Humidity Gradient	20%/hour (maximum)
¹ The system environment must allow sufficient air flow to limit maximum base casting temperatures as defined in Figure 2-2 below.	

2.5.3 Thermocouple Location

Component	Location
Drive base casting	See Figure 2-2

Figure 2-2. Drive Base Casting Thermocouple Location

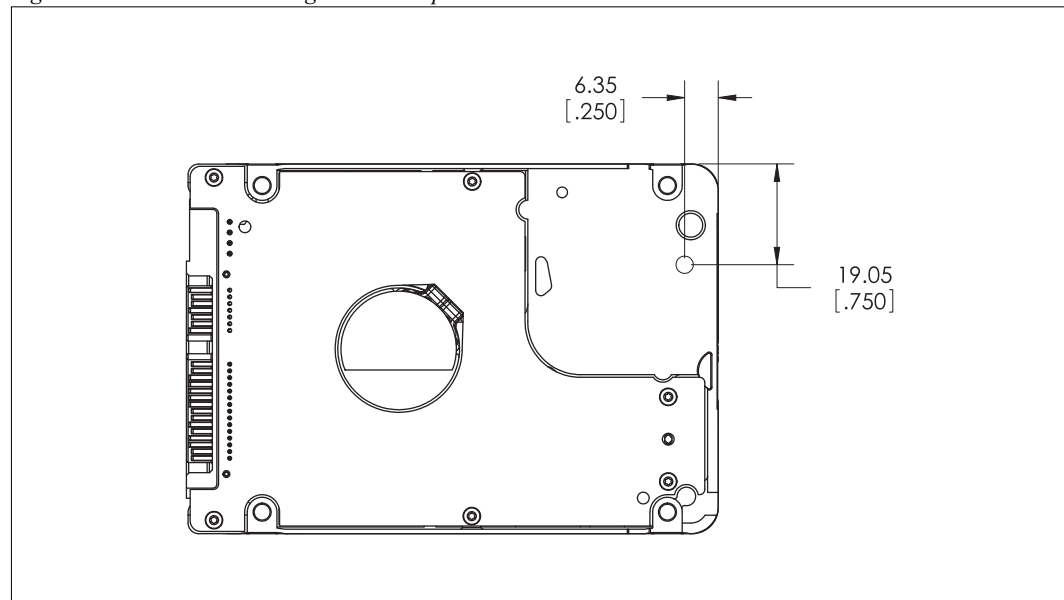

2.5.4 Cooling

If forced air cooling is required, the drive must be positioned to receive airflow from one or more fans as indicated in Figure 2-3.

Figure 2-3. Forced Airflow Direction

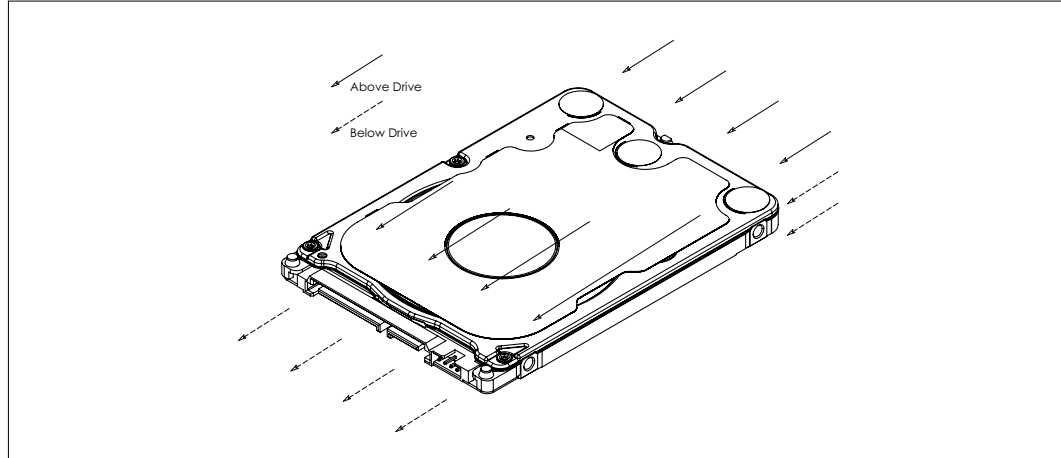

2.5.5 Atmospheric Pressure

Altitude	
Operating	-1,000 feet to 10,000 feet (-305M to 3,048M)
Non-operating	-1,000 feet to 40,000 feet (-305M to 12,192M)

2.5.6 Acoustics

TYPICAL SOUND POWER LEVEL ¹	
Idle Mode (typical dBA) ²	17
Seek Mode (typical dBA) ³	22

¹ Measured per ECMA-74/ISO 7779.
² No audible pure tones.
³ Random seek at a rate of 26 seeks per second.

2.5.7 RoHS (Restriction of Hazardous Substances)

HGST hard drive products manufactured and sold worldwide after June 8, 2011, meet or exceed Restriction of Hazardous Substances (RoHS) compliance requirements as mandated by the RoHS Directive 2011/65/EU. RoHS aims to protect human health and the environment by restricting the use of certain hazardous substances in new equipment, and consists of restrictions on lead, mercury, cadmium, and other substances.

2.6 Reliability Specification and Characteristics

The average Annualized Failure Rate (AFR) calculations assumes the reliability characteristics below. Workload is defined as the number of bytes transferred by the user to/from the drive. If the system(s) that the drive is installed in are not capable of meeting the characteristics listed below, please use a HGST drive that matches your system(s)' capability. Operating drives outside any of the reliability characteristics below will result in a higher AFR.

Reliability Specification	
Average AFR over the Limited Warranty Period	0.50%
Reliability Characteristics	
Base Casting Temperature	40°C
Annual Power on Hours (POH)	<=8760
Total Workload over the Limited Warranty Period	<=90 TB

2.6.1 Average AFR Spectrum

The average AFR spectrum is charted below in

Figure 2-4. Average AFR Spectrum

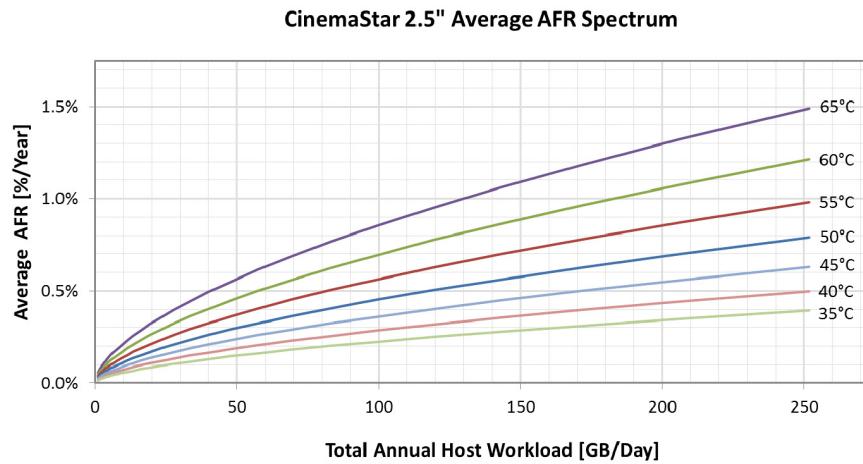

2.7 Device Plug Connector Pin Definitions

The drive interfaces with the host I/O bus via the SATA interface connection, and receives power from the SATA power connection, illustrated in Figure 2-5 below. Table 2-2 identifies the pin definitions of the SATA connectors and the corresponding signal names and signal functions.

Figure 2-5. Standard Factory Connectors

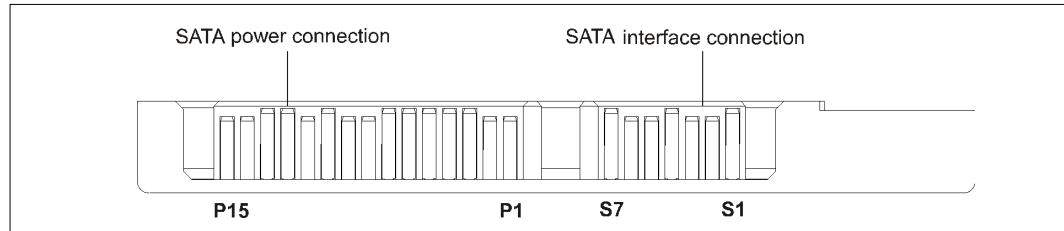

Table 2-2. Device Pin Connector Pin Definitions

Signal segment	S1	Gnd	2nd mate
	S2	A+	Differential signal pair A from Phy
	S3	A-	
	S4	Gnd	2nd mate
	S5	B-	Differential signal pair B from Phy
	S6	B+	
	S7	Gnd	2nd mate
Key and spacing separate signal and power segments			
Power segment	P1	V ₃₃	3.3 V power, NOT CONNECTED
	P2	V ₃₃	3.3 V power, NOT CONNECTED
	P3	V ₃₃	3.3 V power, pre-charge, 2nd mate, NOT CONNECTED
	P4	Gnd	1st mate, GROUND
	P5	Gnd	2nd mate, GROUND
	P6	Gnd	2nd mate, GROUND
	P7	V ₅	5V power, Precharge, 2nd mate
	P8	V ₅	5V power
	P9	V ₅	2nd mate, 5V power
	P10	Gnd	2nd mate, GROUND
	P11	ACT-	Activity LED- (O.D.)/Staggered Spin-up Disable Control
	P12	Gnd	1st mate, GROUND
	P13	V ₁₂	12 V power, pre-charge, 2nd mate, NOT CONNECTED
	P14	V ₁₂	12 V power, NOT CONNECTED
	P15	V ₁₂	12 V power, NOT CONNECTED

2.8 Agency Approvals

CinemaStar Z5K500.B Regulatory Number (R/N): 800025

These drives meet the standards of the following regulatory agencies:

- **Federal Communication Commission:** Verified to comply with FCC Rules for Radiated and Conducted Emission, Part 15, Subpart B, for Class B Equipment.
- **Underwriters Laboratories:** Bi-National UL Standard CAN/CSA-C22.2 No. 60950/UL 60950-1. Standard for Safety of Information Technology Equipment, including Electrical Business Equipment (File E101559).
- **TUV NORD CERT GmbH:** IEC-950 (EN60950) Standard for Safety of Information Technology Equipment, including Electrical Business Equipment. EN60065. Standard of Safety for Audio, Video, and Similar Electronic Apparatus.
- **CE Compliance for Europe:** Complies with EN 55022: 2010 RF/Conducted Emissions and EN 55024; 2010 Immunity requirements. Including EU Directive 2011/65/EU RoHS II requirements.
- **RCM Compliance for Australia and New Zealand:** Verified to comply with AS/NZS CISPR 22 for RF Emissions as required by the Australian Communications Authority.
- **Korean KC Mark:** Registered as a Class-B product with the South Korean Ministry of Information and Communication.
- **Taiwan BSMI EMI Certification:** Certified as a Class-B product with the Bureau of Standards Metrology and Inspection (BSMI).

2.9 Full Model Number Specification

Table 2-3 below provides a summary specification of the model number suffix for this product platform.

Table 2-3. Full Model Number Description

Model Number Format	Product Brand	RPM	Description
HCC545050B7E360	CinemaStar Z5K500.B	5400	CinemaStar Z5K500.B 16MB SATA 3 Gb/s

3.0 PRODUCT FEATURES

- SATA 3 Gb/s
- ATA-8 Streaming
- SilkStream™
- Advanced Format Technology
- Perpendicular Magnetic Recording (PMR)
- Reduced Power Spinup (RPS)
- System-on-Chip (SOC)
- S.M.A.R.T. Command Transport (SCT)
- Reliability Features Set—Data Lifeguard™
- Automatic Defect Retirement
- Hot Plug Support
- Active LED Status
- Fluid Dynamic Bearings (FDB)
- Staggered Spin-Up and Activity Indication (SATA Power Pin 11)
- CacheFlow™
- 48-bit Logical Block Addressing (LBA)
- Power Management
- Self-Monitoring, Analysis, and Reporting Technology (S.M.A.R.T.)
- Security Mode

3.1 SATA 3 Gb/s

SATA 3 Gb/s is the next generation interface for SATA hard drives. It adds to the functionality of the SATA I interface with the following features:

- **Improved Power Management**— provides improved power management features including Host Initiated SATA Power Management (HIPM) and Device Initiated SATA Power Management (DIPM).
- **Staggered Spin-up** — allows the system to control whether the drive will spin up immediately or wait until the interface is fully ready before spinning up.
- **Asynchronous Signal Recovery (ASR)** — robustness feature that improves signal recovery.
- **Enclosure Services** — defines external enclosure management and support features.
- **Backplane Interconnect** — defines how to lay out signal line traces in a backplane.
- **Auto-activate DMA** — provides increased command efficiency through automated activation of the DMA controller.
- **Device Configuration Overlay (DCO)** — allows hiding of supported features via a SATA feature mask.

3.2 ATA-8 Streaming

The industry standard ATA/ATAPI-8 streaming feature command set enhances streaming performance in personal video recorders and other CE devices. ATA-8 streaming commands enable a standardized method of streaming A/V files that offers increased caching performance and reduced error recovery overhead. HGST drives compatible with ATA-8 streaming commands can handle multiple data streams without degradation in video quality, and are optimal for A/V storage applications.

3.3 SilkStream

Optimized for smooth, continuous digital video playback of multiple simultaneous HD streams. SilkStream is compatible with the ATA streaming command set so CE customers can use standard streaming management and error recovery options.

3.4 Advanced Format Technology

Advanced Format Technology is adopted by HGST and other drive manufacturers to increase media format efficiencies, thus enabling larger drive capacities.

In Advanced Formatting, each physical sector is composed of eight 512 byte logical sectors, totalling 4096 bytes. HGST is shipping Advanced Formatting drives as 512 Byte Emulated Devices until full operating system support for the Advanced Formatting host interface is available. 512 Byte Emulated Device drives are backward compatible with 512 byte sector accesses.

3.5 Perpendicular Magnetic Recording (PMR)

In perpendicular magnetic recording (PMR), the magnetization of each data bit is aligned vertically to the spinning disk, rather than longitudinally as has been the case in hard drive technology for decades. In longitudinal recording, as the bits become smaller and closer together, they experience an increasing demagnetizing field, much like two bar magnets that are placed end-to-end repel one another. A property of the media called coercivity must be increased to counteract the demagnetization to keep the bits stable under thermal fluctuations; otherwise data corruption may occur over time. Higher media coercivity has pushed the recording head write field to the limit of known materials.

In perpendicular recording, the adjacent bits attract instead of repel (as with bar magnets placed side by side,) creating more thermally stable bits. In addition, the media contains a magnetically soft underlayer (SUL) beneath the recording layer. This SUL allows a larger effective write field, thus higher coercivity media, enabling further increases in density. Lastly, because of the vertical orientation of the bits, the PMR recording layer tends to be thicker than that used for longitudinal recording, providing increased signal for the read heads. All of these benefits enable HGST engineers to reliably pack more data on a given disk than is possible with conventional longitudinal recording.

3.6 Reduced Power Spinup (RPS)

Applications for 2.5-inch hard drives include USB external hard drives, notebook systems, and Consumer Electronics (CE). Due to the fact that many of these applications are portable in nature, an option for limiting startup current levels and increasing spinup speed is necessary.

To address this requirement, HGST has developed Reduced Power Spinup (RPS) mode. RPS-enabled drives use minimal power consumption during spin up, allowing a greater range of compatibility with various systems and cables in the marketplace.

RPS mode is set via jumper. See Figure 5-4 for more information.

3.7 System-on-Chip (SOC)

The System-on-Chip (SOC) is the foundation for HGST's next generation electronics and firmware architecture. The native SATA SOC lowers component count by integrating a hard disk controller, high performance processor, high speed execution SRAM, and read channel in a 128-pin package. The processor has a 5-stage pipeline which can execute instructions in a single cycle and a DSP engine for enhanced operations. The SOC has on-chip tightly coupled memory for high speed code and data execution that maximizes the processing bandwidth for timing critical operations. It has a high performance disk controller that incorporates maximum flexibility, modularity, performance, and low power consumption. The read/write channel has advanced detection capabilities for high-density drives.

3.8 S.M.A.R.T. Command Transport (SCT)

The SCT Command Transport feature set provides a method for a host to send commands and data to a device and for a device to send data and status to a host using log pages. Standard ATA commands may be interspersed with SCT commands, but SCT commands cannot be nested. SCT commands that do not require a subsequent data transfer operation are not interspersed with any ATA commands or each other.

The SCT Command Transport feature set provides a method for a host to send commands and data to a device and for a device to send data and status to a host using log pages. This capability is used to pass commands through a driver interface or a bridge where new or unknown commands may be filtered and not passed to the drive. SCT is also used for issuing commands that require more than 8 parameter bytes. ATA8-ACS provides detailed information on the usage and capabilities of SCT. The SCT feature set includes the following commands:

- Write Same
- Temperature Reporting

3.8.1 Write Same

The Write Same command allows the host to erase the media, or write a pattern repeatedly across the media, with a minimum of data transfer from the host. The host can clear the entire media to zeros or a specific pattern by sending this command with the pattern as a parameter—no data transfer is necessary. Write Same can write the entire media, or just a portion of the media. The host can monitor the progress of the Write Same by issuing SCT Status requests. This frees the host system to do other tasks while the media is being cleared.

3.8.2 Temperature Reporting

The SCT Temperature Reporting (SCT TR) feature allows a host system to access temperature information in the drive. This information can be used to control fans or adjust the usage of various system components to keep the drive within its normal operating temperature. Applications include Enterprise, Laptop, Desktop and Consumer Electronics. SCT TR reports the maximum and minimum sustained operating limits, warning level limits, and drive damage limits. In addition to reporting the limits, SCT TR returns the current drive temperature (a temperature history which the host can use to predict heating or cooling trends) and the maximum temperature achieved during the lifetime of the drive as well as the highest temperature achieved since the power was applied to the drive. Detailed information on this capability can be found in ATA8-ACS.

3.9 Reliability Features Set

3.9.1 Data Lifeguard™¹

Representing HGST's ongoing commitment to data protection, Data Lifeguard includes features that enhance the drive's ability to prevent data loss. Data Lifeguard data protection utilities include thermal management, an environmental protection system, and embedded error detection and repair features that automatically detect, isolate, and repair problem areas that may develop over the extended use of the hard drive. With these enhanced data reliability features, the drive can perform more accurate monitoring, error repair, and deliver exceptional data security.

This self-tuning feature is performed during offline data collection scan. All user sectors on the hard drive are scanned during times of no activity from the host. Any sector determined to be written poorly (e.g., off-track), or that is difficult to recover (e.g., because of a developing media defect or thermal asperity), is marked for repair. Data Lifeguard actively guards your data, even if S.M.A.R.T. operations are disabled.

All HGST drives are defect-free and low-level formatted at the factory. After prolonged use, any drive, including a HGST drive, may develop defects. If you continue receiving data errors in any given file, use the Data Lifeguard Diagnostics utility to recover, relocate and rewrite the user data to the nearest spare sector and maintain a secondary defect list.

CAUTION: As with all format utilities, some options in the Data Lifeguard Diagnostics utility will overwrite user data.

¹ Default shipping configuration has Data Lifeguard feature disabled for power management optimization.

3.9.2 Thermal Management

The drive is designed with Thermal Management features for high reliability.

- **State-of-the-art mechanical design**—Mechanical design is optimized to reduce the drive's temperature. State-of-the-art thermal dissipation and windage design is employed.
- **Closed loop servo management**—Thermal management monitors the drive temperature and can control servo operations to maintain a stable operating temperature under high temperature conditions. This is a closed loop servo and thermal control system.
- **S.M.A.R.T. HDA Temperature Attribute**—The S.M.A.R.T. HDA Temperature Attribute is supported.
- **Ducted airflow**—Provides protection to the Read/Write element from heated air.

3.9.3 Internal Environmental Protection System

This system protects the inside environment of the drive from contamination. System features include:

- Filtration System to ensure fast clean-up times
- Directed airflow to maximize mechanical cooling
- Increase casting surface area to maximize cooling
- Ducted air flow to protect read/write elements from heated air
- Breather filter located at low pressure area
- Enhanced heat dissipation

3.9.4 Recoverable Errors

A sector marked for repair is written back to the same location. The sector is then read several times to be sure that it was written correctly and that there is no media damage at its location (sector test). If the sector does not easily and consistently read correctly, the sector is then relocated with original data.

3.9.5 Unrecoverable Errors

If an unrecoverable error is found during the offline scan, the sector is marked. Future reads from this location will continue to perform full error recovery. However, the next write to this location will perform a sector test to be sure the media is not damaged, and the sector relocated if the sector test fails.

3.9.6 Self Test

Self Test is a quick way to determine the operation status of a drive. The following Self Tests are supported:

- **Quick Test**: Completes in less than two minutes.
- **Extended Test**: Tests all the critical subsystems of the drive.
- **Conveyance Test**: Quickly identifies issues caused by handling damage.
- **Selective Test**: Scans host-defined sections of the drive.

The test may be run to completion or be performed as a background task as the drive processes other commands from the host. The host may then poll the drive for runtime status and test results. Since the test is embedded in the drive's firmware, it is always available, requires no installation and can be faster and more effective than a software-based drive test.

3.9.7 ATA Error Logging

ATA Error Logging provides an industry standard means to record error events and supporting information that is then accessible by the host. The event record includes the exact command that caused the failure, the response of the drive, the time of the event and information about the four commands immediately prior to the errant command. Error Logging can reliably and quickly determine whether a system problem is the result of a hard drive failure or other component malfunction. Error Logging retains total error count for the life of the drive and complete records for the last five errors.

3.9.8 Defect Management

Every HGST drive undergoes factory-level intelligent burn in, which thoroughly tests for and maps out defective sectors on the media before the drive leaves the manufacturing facility. Following the factory tests, a primary defect list is created. The list contains the cylinder, head, and sector numbers for all defects.

Defects managed at the factory are sector slipped. Grown defects that can occur in the field are mapped out by relocation to spare sectors on the inner cylinders of the drive.

3.10 Automatic Defect Retirement

The automatic defect retirement feature automatically maps out defective sectors while reading or writing. If a defective sector appears, the drive finds a spare sector.

The following item is specific to automatic defect retirement on writes (write auto-relocation):

- Data is always written to disk (using automatic defect retirement if required) and no error is reported.

The following item is specific to automatic defect retirement on reads (read auto-relocation):

- When host retries are enabled, the drive will internally flag any unrecoverable errors (DAMNF or ECC). This flagging allows subsequent write commands to this location to relocate the sector only if the sector test fails.

3.10.1 Error Recovery Process

The drive has five means of error recovery:

- ECC On-the-Fly
- Read/Write Retry Procedure
- Extended Read Retry Procedure

ECC On-the-Fly – If an ECC error occurs, the drive attempts to correct it on-the-fly without retries. Data can be corrected in this manner without performance penalty. The details of the correction algorithm appear in the next section.

Read/Write Retry Procedure – This retry procedure is used by all disk controller error types. If the procedure succeeds in reading or writing the sector being tried, then recovery is complete and the controller continues with the command. Each retry operation also checks for servo errors. The procedure ends when error recovery is achieved or when all possible retries have been attempted.

Extended Read Retry Procedure – This retry procedure tries combinations of positive/negative track offsets and data DAC manipulations to recover the data. This retry procedure applies only to read data recovery. The Read/Write Retry procedure performs the actual retry operation.

When an extended retry operation is successful, the controller continues with the command. The controller clears any changes in track offset or data DAC settings before the command continues.

3.11 Hot Plug Support

SATA supports hot plugging (also known as “hot swapping”), the ability to swap out a failed hard drive without having to power down the system or reboot. This capability contributes to both data availability and serviceability without any associated downtime, making it a critical feature for extending SATA into enterprise applications.

HGST SATA drives support hot plugging only in systems where a SATA hard drive storage backplane is used.

The Serial ATA revision 2.5 specification requires staggered pins for both the hard drive and drive receptacles. Staggered pins mate the power signals in the appropriate sequences required for powering up the hot plugged device. These pins are also specified to handle in excess of the maximum allowed inrush current that occurs during drive insertion. SATA-compliant devices thus need no further modification to be hot pluggable and provide the necessary building blocks for a robust hot plug solution, which typically includes:

- Device detection even with power downed receptacles (typical of server applications).
- Pre-charging resistors to passively limit inrush current during drive insertion.
- Hot plug controllers to actively limit inrush current during drive insertion.

3.12 Active LED Status

The drive supports external LED requirements. It provides an activity LED output which is ON during command execution and OFF otherwise.

The drive strength of this open drain drive active signal is that it can sink 12mA to 0.4V Max. It is 5V tolerant, meaning that the external LED may be driven from +5V or +3.3V so long as the Host system provides a series resistor to limit the LED current to the lower of 12mA or the rated operating current of the LED. As an example with +5V and a 2 volt forward drop across a 10mA LED, a 300 Ohm 5% 1/16W resistor would be suitable. In the case of a 3.3V supply for the same LED, the resistor would be 130 Ohm 5% 1/16W.

The pin corresponding to P11 shall be used for Active LED (see “Device Pin Connector Pin Definitions” on page 19).

3.13 Fluid Dynamic Bearings (FDB)

Bearing design that incorporates a layer of high-viscosity lubricant instead of ball bearings in the hard drive spindle motor. As an alternative to conventional ball bearing technology, FDB designs provide increased non-operational shock resistance, speed control, and improved acoustics.

3.14 Staggered Spinup and Activity Indication (SATA Power Pin 11)

SATA device power connector pin 11 (see “Standard Factory Connectors” on page 19) is defined as a means by the host to DISABLE staggered spinup and it may also be used by the device to provide the host with an activity indication. According to the SATA II specs, "Staggered Spin-up Disable and Activity Signal shall not be enabled at the same time."

3.14.1 Staggered Spinup

When multiple disks are installed in an enclosure, it is desirable to provide a simple mechanism by which a subsystem controller can sequence hard drive initialization to minimize the current load presented during power up. Staggered spinup provides this mechanism by preventing the hard drives from spinning up until after successful PHY initialization (i.e., after PHY enters DP7:DR_Ready state).

Staggered spinup is only applicable during initial power-up. If a drive is spun down using ATA commands—as a result of having been placed in Standby or Sleep power modes, for example—the

drive shall spin up following the rules that govern spinup from low power modes described in ATA/ATAPI-6 or later.

3.14.2 Activity Indication

The host controller through SATA power pin 11 may access storage device status and activity. The signal provided by the device for activity indication is a low-voltage low-current signal. It is not suitable for directly driving an LED. A buffer circuit external to the device must be employed to drive the LED. The activity signal is based on an open-collector or open-drain active low driver. The device shall tolerate the activity signal being shorted to ground.

3.15 CacheFlow™

CacheFlow is HGST's unique, multi-generation disk caching system. It incorporates read cache with write cache.

HGST designed CacheFlow to obtain maximum performance with today's most popular operating systems and applications. CacheFlow increases performance over prior caching algorithms by increasing the number of times that requested data is in the cache. This reduces the number of host commands that require actual media access thereby improving overall drive performance.

Typical applications perform a variety of access patterns, such as random, sequential, and repetitive. CacheFlow is designed to dynamically adapt to the changes in access patterns that occur during the course of application execution.

Random mode is the default operational mode for CacheFlow. Once CacheFlow detects a sequential access pattern, it leaves random mode. CacheFlow also performs predictive read operations to increase the probability that data requested in future commands already exists in the cache.

CacheFlow partitions the buffer into multiple segments to allow for the fact that applications may access multiple non-contiguous areas on the disk. CacheFlow tracks the amount of valid data in each segment and controls the deallocation of segments to maximize drive performance.

3.15.1 Write Cache

CacheFlow is designed to improve both single and multi-sector write performance by reducing delays caused by seek time and rotational latency.

The write cache adaptively detects random and sequential access patterns during application execution.

If a defective sector is found during a write cache operation, that sector is automatically relocated before the write occurs.

3.15.2 Read Cache

CacheFlow implements a multiple segment read cache. Cache segments are assigned to read commands as they are received from the host.

Each read segment consists of pre and post read sectors in addition to the host-requested sectors. This maximizes the amount of cache data in the drive's buffer, thereby increasing the likelihood of cache hits and improving overall performance.

3.15.3 48-bit Logical Block Addressing (LBA)

The 48-bit Address feature set allows devices with capacities up to approximately 281 tera sectors or approximately 144 peta bytes. In addition, the number of sectors that may be transferred by a single command are increased by increasing the allowable sector count to 16 bits.

48-bit Address					
Bits (47:40)	Bits (39:32)	Bits (31:24)	Bits (23:16)	Bits (15:8)	Bits (7:0)
LBA High (exp)	LBA Mid (exp)	LBA Low (exp)	LBA High	LBA Mid	LBA Low

16-bit Sector Count	
Bits (15:8)	Bits (7:0)
Sector Count (exp)	Sector Count

3.16 Power Management

The drives support the ATA power management commands that lower the average power consumption of the hard drives. For example, to take advantage of the lower power consumption modes of the drive, an energy efficient host system could implement a power management scheme that issues a Standby Immediate command when a host resident disk inactivity timer expires. The Standby Immediate command causes the drive to spin down and enter a low-power mode. Subsequent disk access commands would cause the drive to spin up and execute the new command.

To avoid excessive wear on the drive due to the starting and stopping of the HDA, set the host's disk inactivity timer to no shorter than ten minutes.

The drives also support the SATA power management feature that lowers the average power consumption of the SATA interface.

3.17 Self-Monitoring, Analysis, and Reporting Technology (S.M.A.R.T.)

S.M.A.R.T. helps you monitor a drive's internal status through diagnostic commands at the host level.

The drive monitors Read Error Rate, Start/Stop Count, Re-allocated Sector Count, Seek Error Rate, Power-on Hours Count, Spin-up Retry Count, Drive Calibration Retry Count, Drive Power Cycle Count, Offline Scan Uncorrectable Sector Count, Ultra ATA CRC Error Rate, Multi-zone Error Rate, Spin-up Time, Relocation Event Count, and Current Pending Sector Count. The hard drive updates and stores these attributes in the reserved area of the disk. The drive also stores a set of attribute thresholds that correspond to the calculated attribute values. Each attribute threshold indicates the point at which its corresponding attribute value achieves a negative reliability status.

3.18 Security Mode

The Security Mode feature set allows the user to create a device lock password that prevents unauthorized hard drive access even if the drive is removed from the computer.

3.18.1 Master and User Passwords

The manufacturer/dealer can set a master password using the Security Set Password command, without enabling the device lock function. The user password should be given or changed by a system user.

Master Password Identifier is supported and set to a default value of 00FE. If a Master Password is set via a Security Set Password Command, a valid Master Password Revision code value of 0001h – 00FEh must be used. A Master Password Identifier of 0000h is ignored.

When the master password is set, the drive does *not* enable the device lock function. When the user password is set, the drive enables the device lock function, and the drive is locked after the next power on reset or hard reset.

3.18.2 Security Levels

High - If High level security is set and the user password is forgotten, the master password can be used to unlock the drive and access the data.

Maximum - If Maximum level security is set and the user password is forgotten, data access is impossible. Only the master password with a Security Erase Unit command can unlock the drive when the device lock function is enabled and the user password has been forgotten. When the Security Erase Unit command is used to unlock the drive, all user data is erased.

4.0 ATA COMMAND SET

4.1 Host Interface Commands

4.1.1 ACS3 Commands

Table 4-1 lists the hexadecimal codes specific to each ACS3 command supported by these hard drives. Refer to the T13/2161-D ACS3 specification for full details on each command.

Table 4-1. ACS3 Command Opcodes

COMMAND	HEX OPCODE
CHECK POWER MODE	E5
OBSOLETE	B1
DOWNLOAD MICROCODE	92
EXECUTE DEVICE DIAGNOSTIC	90
FLUSH CACHE	E7
FLUSH CACHE EXT	EA
IDENTIFY DEVICE	EC
IDLE	E3
IDLE IMMEDIATE	E1
NOP	00
READ BUFFER	E4
READ DMA	C8
READ DMA EXT	25
READ FPDMA QUEUED	60
READ LOG EXT	2F
READ LOG DMA EXT	47
READ MULTIPLE	C4
READ MULTIPLE EXT	29
READ NATIVE MAX ADDRESS	F8
READ NATIVE MAX ADDRESS EXT	27
READ SECTOR(S)	20
READ SECTORS(S) EXT	24
READ VERIFY SECTOR(S) EXT	42
READ VERIFY SECTORS(S)	40
S.M.A.R.T.	B0
SECURITY DISABLE PASSWORD	F6
SECURITY ERASE PREPARE	F3
SECURITY ERASE UNIT	F4
SECURITY FREEZE LOCK	F5
SECURITY SET PASSWORD	F1
SECURITY UNLOCK	F2
SET FEATURES	EF
SET MAX	F9
SET MAX ADDRESS EXT	37
SET MULTIPLE	C6
SLEEP	E6
STANDBY	E2

COMMAND	HEX OPCODE
STANDBY IMMEDIATE	E0
WRITE BUFFER	E8
WRITE DMA	CA
WRITE DMA EXT	35
WRITE FPDMA QUEUED	61
WRITE LOG EXT	3F
WRITE MULTIPLE	C5
WRITE MULTIPLE EXT	39
WRITE SECTOR(S)	30
WRITE SECTOR(S) EXT	34
WRITE UNCORRECTABLE EXT	45
CONFIGURE STREAM	51
READ STREAM EXT	2B
READ STREAM DMA EXT	2A
WRITE STREAM EXT	3A
WRITE STREAM DMA EXT	3B

4.1.2 Download MicroCode -92h

Table 4-2 lists the Download Microcode command allows the host to download the hard drive's firmware.

Table 4-2. Download Microcode Subcommand field

CODE	Subcommand Description
03h	Download with offsets and save microcode for immediate and future use.
07h	Download and save microcode for immediate and future use.
0Eh	Download with offsets and save microcode for future use.
0Fh	Activate downloaded microcode.

4.1.3 Obsolete Commands

Table 4-3 lists the hexadecimal codes specific to each obsolete command supported by these hard drives.

Table 4-3. Obsolete Command Opcodes

COMMAND	HEX OPCODE
INITIALIZE DEVICE PARAMETERS	91
RECALIBRATE	10
SEEK	70
DEVICE CONFIGURATION OVERLAY	B1

4.1.4 SCT Commands

SCT commands provide capabilities not covered in ATA/ATAPI-7 for commands that do not fit the ATA command delivery model. Some SCT commands report completion when the command begins execution. Execution progress for these commands may be checked by requesting SCT status. For instance, the host can track the progress of a Write Same command by issuing a status request once per minute. See ATA8-ACS for a full description of SCT.

Table 4-4. SCT Action Codes

ACTION CODE	DESCRIPTION
0000h	RESERVED
0001h	Long Sector Access
0002h	Write Same
0003h	SCT Error Recovery Control command
0004h	Features Control
0005h	SCT Data Tables
0006h	Vendor specific
0007h	BFFFh Reserved
C000h	FFFFh Vendor specific

4.2 S.M.A.R.T. (B0h)

The S.M.A.R.T. command provides access to attribute values, S.M.A.R.T. status, and other S.M.A.R.T. information. These commands can be used for logging and reporting purposes, and for accommodating special user needs.

Prior to writing the S.M.A.R.T. command to the Command Register, the host must write key values into the LBA Mid and LBA High Registers (4Fh, C2h) or the command will be aborted and an error will be reported.

The S.M.A.R.T. command has several sub-commands that are selectable via the Features Register when the host issues the S.M.A.R.T. command. To select a sub-command, the host must write the appropriate sub-command code to the Features Register before issuing the S.M.A.R.T. command. The sub-commands and their respective codes are listed below. For more detailed information on executing S.M.A.R.T. commands, please see the ATA specification.

4.2.1 Read Attribute Values Sub-Command

This command returns a sector of data with the drive's S.M.A.R.T. data structure.

Table 4-5. Definitions for the 512 Bytes.

BYTE	VALUE	DESCRIPTION
0 - 1	0010h	S.M.A.R.T. Data Structure Revision
2 - 361	XX	S.M.A.R.T. Attribute Data
362	XX	Offline data collection status 0Xh OL disabled 8Xh OL enabled X0h scan not run X2h scan complete X4h scan suspended X5h scan aborted
363	XX	Self-Test execution status byte. 00h The previous self-test routine completed without error or no self-test has ever been run 01h The self-test routine was aborted by the host

BYTE	VALUE	DESCRIPTION
		02h The self-test routine was interrupted by the host with a hard or soft reset 03h A fatal error or unknown test error occurred while the device was executing its self-test routine. The device was unable to complete the self-test routine. 04h The previous self-test completed having a test element that failed. The test element that failed is not known. 05h The previous self-test completed having a test element that failed. The electrical element of the test failed. 06h The previous self-test completed having a test element that failed. The servo (and/or seek) test element of the test failed. 07h The previous self-test completed having a test element that failed. The read element of the test failed. 08h The previous self-test completed having a test element that failed. The element damage is suspected to be caused by handling. 09-0Eh Reserved 0Fh Self-test routine in progress
364 - 365	XX	Total time in seconds to complete offline data collection activity
366	XX	Reserved
367	7Bh	Offline data collection capability. Bits are as follows: 0 1 = Offline Immediate Command supported 1 1 = Auto Offline enable\disable command supported 2 0 = Offline will suspend on and will resume after host command 3 1 = Offline read scan implemented 4 1 = DST Short and Extended tests supported 5 1 = DST Conveyance test supported 6 1 = DST Selective test supported 7 0 = Reserved
368 - 369	0003h	S.M.A.R.T. Capability. Bits are as follows: 1 1 = The device saves SMART data prior to going into a power saving mode 1 1 = Device complies with SMART data autosave after an event 2-15 Reserved
370	01h	Error logging capability. Bits are as follows: 0 1 = Error logging supported 1 Reserved
371	XX	Reserved
372	XX	Short self-test routine completion time in minutes
373	XX	Extended self-test routine completion time in minutes
374	XX	Conveyance self-test routine completion time in minutes
375 - 510	XX	Reserved
511	XX	Checksum

4.2.2 Supported Attributes

The drive supports the following attributes.

Attribute	Attribute ID Number	Pre-Failure/Advisory Bit (Status Flags bit 0) ¹
Read Error Rate	1	Pre-Failure
Spin-up Time	3	Pre-Failure
Start/Stop Count	4	Advisory
Re-allocated Sector Count	5	Pre-Failure
Seek Error Rate	7	Advisory
Power-on Hours Count	9	Advisory
Spin-up Retry Count	10	Advisory
Drive Calibration Retry Count	11	Advisory
Drive Power Cycle Count	12	Advisory
Emergency Retract Cycles	192	Advisory
Load/Unload Cycles	193	Advisory
HDA Temperature ²	194	Advisory
Relocation Event Count	196	Advisory
Current Pending Sector Count	197	Advisory
Offline Scan Uncorrectable Sector Count	198	Advisory
Ultra DMA CRC Error Rate	199	Advisory
Multi-zone Error Rate	200	Advisory

¹ Status bits are typical but may vary.
² See "Temperature Reporting" on page 24 for a better mechanism.

Attributes that use the Pre-Failure/Advisory Bit Set can predict potential future degrading or faulty conditions. Attributes with the Failure/Advisory Bit Clear are used for informational purposes only, they do not indicate impending drive failure.

The S.M.A.R.T. data saving process is a background task. After a pre-determined idle period, the self-monitoring data is automatically saved to the disk.

4.2.3 Read Log Sector

There are several logs that can be read with the S.M.A.R.T. Read Log Sector sub-command. The LBA Low Register indicates the log sector to be returned.

Table 4-6. Log Address Definition

Log Address	Log Name	Feature Set	R/W	Access
00h	Log directory	none	RO	GPL, SL
01h	Summary SMART Error log	SMART	RO	SLa
02h	Comprehensive SMART Error log	SMART	RO	SLa
03h	Extended Comprehensive SMART Error log	SMART	RO	GPLb
04h	Device Statistics	N/A	RO	GPL, SL
05h	Reserved for CFA	Reserved		
06h	SMART Self-Test log,	SMART	RO	SLa
07h	Extended SMART Self-Test log	SMART	RO	GPLb
08h	Power Conditions	Reserved	RO	GPLb
09h	Selective Self-Test log	SMART	R/W	SLa
0Ah	Device Statistics Notification,	Reserved	R/W	GPLb
0Bh	Reserved for CFA			
0Ch	Reserved			
0Dh	LPS Mis-alignment log	Reserved	RO	GPL, SL
0Eh-0Fh	Reserved			
10h	NCQ Command Error log	NCQ	RO	GPLb
11h	SATA Phy Event Counters log	none	RO	GPLb
12h	SATA NCQ Queue Management log	NCQ	RO	GPLb
13h	SATA NCQ Send and Receive log	NCQ	RO	GPLb
14h-17h	Reserved for Serial ATA			
18h	Reserved			
19h	LBA Status	none	RO	GPLb
1Ah-20h	Reserved			
20h	Obsolete			
21h	Write Stream Error log	Streaming	RO	GPLb
22h	Read Stream Error log	Streaming	RO	GPLb
23h	Obsolete			
24h	Current Device Internal Status Data log	none	RO	GPLb
25h	Saved Device Internal Status Data log	none	RO	GPLb
26h-2Fh	Reserved			
30h	IDENTIFY DEVICE data	none	RO	GPL, SL
31h-7Fh	Reserved			
80h-9Fh	Host Specific	SMART	R/W	GPL, SL
A0h-DFh	Device Vendor Specific	SMART	VS	GPL, SL
E0h	SCT Command/Status	Reserved	R/W	GPL, SL
E1h	SCT Data Transfer	Reserved	R/W	GPL, SL

Log Address	Log Name	Feature Set	R/W	Access
E2h-FFh	Reserved			
RO - Log is read only. R/W - Log is read or written. VS - Log is vendor specific thus read/write ability is vendor specific. GPL - General Purpose Logging SL - SMART Logging The device shall return command aborted if a GPL feature set (see 4.11) command accesses a log that is marked only with SL. The device shall return command aborted if a SMART feature set (see 4.19) command accesses a log that is marked only with GPL.				

4.3 Identify Device (ECh)

The Identify Device command transfers 512 bytes of data that specify the drive's parameters. Table 4-7 lists the parameters read by the host.

Table 4-7. Identify Device Command

WORD	FIELD DESCRIPTION	f = fixed v = variable x = not defined	Drive Program Power-on Default Value
	X 14:8 Retired	X	
	X 7:6 Obsolete	X	
	X 5:3 Retired	X	
	V 2 Incomplete response	V	
	X 1 Retired	X	
	0 Reserved		
1	Obsolete (Number of logical cylinders)	X	3FFFh
2	Specific Configuration	V	C837h
3	Obsolete (Number of logical cylinders)	X	0010h
4-5	Retired	X	0000h
6	Obsolete (Number of logical sectors per logical track)	X	003Fh
7-8	Reserved for assignment by the CompactFlash™ Association	F	0000h
9	Retired	X	0000h
10-19	Serial Number (ATA String)	V	"nnnnnnnn"
20-21	Retired	X	00008000h
22	Obsolete	X	0000h
23-26	Firmware Revision (ATA String)	F	"nn.nnnnn"
27-46	Model Numbers (ATA String)	F	"HGST HCC545050B7E360"
47	READ/WRITE MULTIPLE support Bits 15-8: 80h Bits 7-0: 00h = Reserved 01h-FFh = Maximum number of logical sectors that shall be transferred per DRQ data block on READ/WRITE MULTIPLE commands	F F	8010h

WORD	FIELD DESCRIPTION	f = fixed v = variable x = not defined	Drive Program Power-on Default Value
48	Trusted Computing feature set options Bit 15: Shall be cleared to zero Bit 14: Shall be set to one Bit 13-1: Reserved for the Trusted Computing Group Bit 0: If set, Trusted Computing feature set is supported	F F F	4000h
49	Capabilities Bits 15-14: Reserved for the IDENTIFY PACKET DEVICE command. Bit 13: If set, Standby timer values as specified in this standard are supported 0 = Standby timer values shall be managed by the device Bit 12: Reserved for the IDENTIFY PACKET DEVICE command. Bit 11: If set, IORDY supported Bit 10: If set, IORDY may be disabled Bit 9: If set, LBA supported Bit 8: If set, DMA supported Bits 7-2: Reserved Bit 1: Long Physical Sector Alignment Error reporting	F F F F F V	2F00h
50	Capabilities Bit 15: Shall be cleared to zero. Bit 14: Shall be set to one. Bit 13-2: Reserved. Bit 1: Obsolete Bit 0: 1 = There is a minimum Standby time value and it is vendor specific. 0 = There is no minimum Standby timer value.	F F X F	4001h
51-52	Obsolete	X	0000h
53	Additional Words Valid Bit 8-15: Free-fall Control Sensitivity 00h = Vendor's recommended setting 01h-FFh = Sensitivity level. A larger number is a more sensitive setting. Bit 7-3: Reserved Bit 2: If set, the fields reported in word 88 are valid Bit 1: If set, the fields reported in words 70-64 are valid Bit 0: Obsolete	V F F X	0006h
54-58	Obsolete Word 54: Number of current logical cylinders Word 55: Number of current logical heads Word 56: Number of current logical sectors per track Word 57-58: Current capacity in sectors	X	3FFF0010003FFC1000FBh

WORD	FIELD DESCRIPTION	f = fixed v = variable x = not defined	Drive Program Power-on Default Value
59	Current Blocking Factor Bit 15: If set, The BLOCK ERASE EXT command is supported Bit 14: If set, The OVERWRITE EXT command is supported Bit 13: If set, The CRYPTO Scramble EXT command is supported Bit 12: If set, The Sanitize feature set is supported Bit 11: If =1, commands allowed during sanitize operation are as specified by this standard if = 0, commands allowed during sanitize are as specified by ACS-2 Bit 10: The SANITIZE ANTIFREEZE LOCK EXT command is supported Bit 9 Reserved Bit 8: If set, Multiple local sector setting is valid Bits 7-0: Current setting for number of logical sectors that shall be transferred per DRQ data block on READ/WRITE Multiple commands	F F F F F F V V	0100h
60-61	Total number of user addressable logical sectors for 28 bit commands (DWord)	F	::: '\$::: h
62	Obsolete	X	0000h
63	Multi-Word DMA Transfer Mode Supported Bit 15-11: Reserved Bit 10: If set, Multiword DMA mode 2 is selected Bit 9: If set, Multiword DMA mode 1 is selected Bit 8: If set, Multiword DMA mode 0 is selected Bit 7-3: Reserved Bit 2: If set, Multiword DMA mode 2 Bit 1: If set, Multiword DMA mode 1 Bit 0: If set, Multiword DMA mode 0	V V V F F F	0107h
64	Advanced PIO Modes Supported Bits 15-2: Reserved Bits 1-0: PIO Modes 3 and 4 supported	F	0003h
65	Min. Multi-Word DMA Transfer Cycle Time	F	0078h
66	Manufacturer Recommended Multi-Word DMA Cycle Time	F	0078h
67	Min. PIO Transfer Cycle Time without flow control	F	0078h
68	Min. PIO Transfer Cycle Time with IORDY flow control	F	0078h

WORD	FIELD DESCRIPTION	f = fixed v = variable x = not defined	Drive Program Power-on Default Value
82	Command and feature sets supported Bit 15: Obsolete Bit 14: If set, NOP command supported Bit 13: If set, Read buffer command supported Bit 12: If set, Write buffer command supported Bit 11-10: Obsolete Bit 9: If set, Device Reset command supported Bit 8-7: Obsolete Bit 6: If set, read look-ahead supported Bit 5: If set, The volatile write cache supported Bit 4: Cleared to 0 to indicate that the PACKET feature set is not supported. Bit 3: If set, mandatory Power Management Feature Set supported Bit 2: Obsolete Bit 1: If set, Security Feature Set supported Bit 0: If set, SMART Feature Set supported	X F F F X F X F F F F X F F	746Bh
83	Command and feature sets supported Bit 15: Shall be cleared to 0 Bit 14: Shall be set to 1 Bit 13: If set, Flush Cache EXT command supported Bit 12: If set, mandatory Flush Cache command supported Bit 11: Obsolete Bit 10: If set, 48-bit Address Feature Set supported Bit 9-8: Obsolete Bit 7: Reserved Bit 6: If set, Set Features subcommand required to spin-up after power-up Bit 5: If set, PUIS feature set supported Bit 4: Obsolete Bit 3: If set, APM feature set supported Bit 2: If set, CFA feature set supported Bit 1: Obsolete Bit 0: If set, Download Microcode command supported	F F F F X F X F F X F F X F	7D69h
84	Command and feature sets supported Bit 15: Shall be cleared to 0 Bit 14: Shall be set to 1 Bit 13: If set, Idle Immediate with Unload Feature supported Bit 12-11: Obsolete Bits 10-9: Obsolete Bit 8: If set, World wide name supported Bit 7: Obsolete Bit 6: If set, Write DMA FUA EXT and Write Multiple FUA EXT commands supported Bit 5: If set, GPL feature set supported Bit 4: If set, Streaming Feature Set supported Bit 3: Obsolete Bit 2: Reserved Bit 1: If set, SMART Self-Test supported Bit 0: If set, SMART Error Logging supported	F F F X X F X F F F F F X F F	6733h

WORD	FIELD DESCRIPTION	f = fixed v = variable x = not defined	Drive Program Power-on Default Value
85	<p>Command and feature sets supported or enabled</p> <ul style="list-style-type: none"> Bit 15: Obsolete Bit 14: If set, NOP command supported Bit 13: If set, Read Buffer command supported Bit 12: If set, Write Buffer command supported Bit 11: Obsolete Bit 10: Obsolete Bit 9: If set, DEVICE RESET command supported Bit 8: Obsolete (SERVICE interrupt enabled) Bit 7: Obsolete (Release Interrupt enabled) Bit 6: If set, Read look-ahead enabled Bit 5: If set, Volatile Write cache enabled Bit 4: Shall be cleared to 0 to indicate that the PACKET feature set is not supported Bit 3: Shall be set to 1 to indicate that the Mandatory Power Management feature set is supported Bit 2: Obsolete Bit 1: If set, Security Feature Set enabled Bit 0: If set, SMART Feature Set enabled 	<ul style="list-style-type: none"> X F F F X X F X X V V F F X V V 	7469h
86	<p>Commands and feature sets supported or enabled</p> <ul style="list-style-type: none"> Bit 15: If set, Words 119-120 are valid Bit 14: Reserved Bit 13: If set, Flush Cache EXT command supported Bit 12: If set, Flush Cache command supported Bit 11: Obsolete Bit 10: If set, 48-bit Address Feature Set supported Bit 9-8: Obsolete Bit 7: Obsolete (Reserved for Address offset reserved Area Boot Method) Bit 6: If set, Set Features subcommand required to spin-up after power-up Bit 5: If set, PUIS feature set enabled Bit 4: Obsolete Bit 3: If set, APM feature set enabled Bit 2: If set, CFA Feature Set enabled Bit 1: Obsolete Bit 0: If set, Download Microcode command supported 	<ul style="list-style-type: none"> F F F F X F X X F V X V F F X F 	BC49h
87	<p>Commands and feature sets supported or enabled</p> <ul style="list-style-type: none"> Bit 15: Shall be cleared to zero Bit 14: Shall be set to 1 Bit 13: If set, Idle Immediate with Unload Feature supported Bit 12-11 Obsolete Bit 10-9: Obsolete Bit 8: If set, 64-bit World wide name supported Bit 7: Obsolete Bit 6: If set, Write DMA FUA EXT and Write Multiple FUA EXT commands supported Bit 5: If set, GPL Feature Set supported Bit 4: Obsolete Bit 3: Obsolete Bit 2: If set, Media serial number is valid Bit 1: If set, SMART Self-Test supported Bit 0: If set, SMART Error Logging supported 	<ul style="list-style-type: none"> F F F X X F X F F X X X V F F 	6723h

WORD	FIELD DESCRIPTION	f = fixed v = variable x = not defined	Drive Program Power-on Default Value
88	Ultra DMA modes Bit 15: Reserved Bit 14: If set, Ultra DMA Mode 6 is selected Bit 13: If set, Ultra DMA Mode 5 is selected Bit 12: If set, Ultra DMA Mode 4 is selected Bit 11: If set, Ultra DMA Mode 3 is selected Bit 10: If set, Ultra DMA Mode 2 is selected Bit 9: If set, Ultra DMA Mode 1 is selected Bit 8: If set, Ultra DMA Mode 0 is selected Bit 7: Reserved Bit 6: Ultra DMA mode 6 supported Bit 5: Ultra DMA mode 5 supported Bit 4: Ultra DMA mode 4 supported Bit 3: Ultra DMA mode 3 supported Bit 2: Ultra DMA mode 2 supported Bit 1: Ultra DMA mode 1 supported Bit 0: Ultra DMA mode 0 supported	V V V V V V V V F F F F F F F	007Fh
89	Bit 15: If set, Extended Time is reported in bits 14:0 if set 0, Time is reported in bits 7:0 and bits 14:8 are served Bit 14-8: Extended Time required for Normal Erase mode SECURITY ERASE UNIT command Bit 7-0: Time required for Normal Erase mode SECURITY ERASE UNIT command	F	803(h
90	Bit 15: If set, Extended Time is reported in bits 14:0 if set 0, Time is reported in bits 7:0 and bits 14:8 are served Bit 14-8: Extended Time required for Normal Erase mode SECURITY ERASE UNIT command Bit 7-0: Time required for Normal Erase mode SECURITY ERASE UNIT command	F	803(h
91	Bit 15-8: Reserved Bit 7-0: Current APM level value	V	0080h
92	Master Password Identifier	V	::: 9h

WORD	FIELD DESCRIPTION	f = fixed v = variable x = not defined	Drive Program Power-on Default Value
93	<p>Hardware reset result</p> <p>Bit 15: Shall be cleared to zero.</p> <p>Bit 14: Shall be set to one for PATA devices.</p> <p>Bit 13: 1 = device detected the CBLID-above ViHB (see ATA8-APT) 0 = device detected the CBLID-below ViL (see ATA8-APT)</p> <p>Bit 12:8 Device 1 hardware reset result. Device 0 shall clear these bits to zero. Device 1 shall set these bits as follows:</p> <p>12 Reserved</p> <p>11 Device 1 asserted PDIAG-.</p> <p>10:9 These bits indicate how Device 1 determined the device number:</p> <p>00 = Reserved</p> <p>01 = a jumper was used.</p> <p>10 = the CSEL signal was used.</p> <p>11 = some other method was used or the method is unknown.</p> <p>8 Shall be set to one.</p> <p>Bit 7:0 Device 0 hardware reset result. Device 1 shall clear these bits to zero. Device 0 shall set these bits as follows:</p> <p>7 Reserved</p> <p>6 Device 0 responds when Device 1 is selected.</p> <p>5 Device 0 detected the assertion of DASP-.</p> <p>4 Device 0 detected the assertion of PDIAG-.</p> <p>3 Device 0 passed diagnostics.</p> <p>Bit 2:1 These bits indicate how Device 0 determined the device number:</p> <p>00 = Reserved</p> <p>01 = a jumper was used.</p> <p>10 = the CSEL signal was used.</p> <p>11 = some other method was used or the method is unknown.</p> <p>Bit 0 Shall be set to one for PATA devices.</p>	<p>F</p> <p>F</p> <p>V</p> <p>V</p> <p>F</p> <p>F</p> <p>V</p> <p>V</p> <p>V</p> <p>V</p> <p>F</p>	0000h
94	Obsolete	X	0000h
95	Stream Minimum Request Size	F	0008h
96	Stream Transfer Time - DMA	V	0000h
97	Stream Access Latency -DMA and PIO	V	0000h
98-99	Stream Performance Granularity (Dword)	F	86A0 0001h
100-103	Total number of User Addressable Logical Sectors (QWord)	V	*\$' '\$' 5', '\$\$\$\$ '\$\$\$\
104	Streaming Transfer Time - PIO	V	0000h
105	Maximum number of 512 byte blocks per Data Set Management command	V	0000h
106	<p>Physical sector size / logical sector size</p> <p>Bit 15: Shall be cleared to 0</p> <p>Bit 14: Shall be set to 1</p> <p>Bit 13: If set, Device has multiple logical sectors per physical sector.</p> <p>Bit 12: If set, Device Logical Sector longer than 256 Words</p> <p>Bits 11-4: Reserved</p> <p>Bits 3-0: 2X logical sectors per physical sector</p>	<p>F</p> <p>F</p> <p>F</p> <p>F</p> <p>F</p>	6003h
107	Inter-seek delay for ISO 7779 standard acoustic testing	F	0000h
108-111	World Wide Name	F) \$\$%(99*) 6: , '+* , +\

WORD	FIELD DESCRIPTION	f = fixed v = variable x = not defined	Drive Program Power-on Default Value
168	Device Nominal Form Factor Bit 15-4: Reserved Bit 3-0: Device Nominal Form Factor	F	0003h
169	Data Set Management Command Bit 15-1: Reserved Bit 0: if set, the Trim bit in the Data Set Management command supported	F	0000h
170-173	Additional Product Identifier	F	0000h
174-175	Reserved		0000h
176-205	Current Media Serial number	F	0000h
206	SCT Command Transport Bit 15-12: Vendor Specific Bit 11-8: Reserved Bit 7: Reserved for Serial ATA Bit 6: Reserved Bit 5: If set, SCT Data tables command supported Bit 4: If set, SCT Features Control command supported Bit 3: If set, SCT Error Recovery Control command supported Bit 2: If set, SCT Write Same command supported Bit 1: If set, Obsolete Bit 0: If set, SCT Command Transport supported	X F F F F F X F	3035h
207-208	Reserved		0000h
209	Alignment of logical blocks within a physical block Bit 15: Shall be cleared to zero Bit 14: Shall be set to one Bits 13-0: Logical sector offset within the first physical sector where the first logical sector is placed.	F F F	4000h
210-211	Write-Read-Verify Sector Count Mode 3	V	0000h
212-213	Write-Read-Verify Sector Count Mode 2	F	0000h
214-216	Obsolete	X	0000h
217	Nominal media rotation rate	F	1518h
218	Reserved		0000h
219	Obsolete	X	0000h
220	Bit 15-8: Reserved Bit 7-0: Write-Read-Verify feature set current mode	V	0000h
221	Reserved		0000h
222	Transport major version number 0000h or FFFFh=device does not report version Bits 15-12: Transport Type (0h=Parallel 1h=Serial 2h-Fh=Reserved) Bits 11-7: Reserved Bit 6 : SATA Rev. 3.1 Bit 5: SATA Rev. 3.0 Bit 4: SATA Rev. 2.6 Bit 3: SATA Rev. 2.5 Bit 2 : SATA II: Extensions Bit 1: SATA 1.0a Bit 0: ATA8-AST	F F F F F F F	107Eh
223	Transport minor version number	F	0000h
224-229	Reserved		0000h

WORD	FIELD DESCRIPTION	f = fixed v = variable x = not defined	Drive Program Power-on Default Value
230-233	Extended Number of User Addressable Sectors (Qword)	V	0000h
234	Minimum number of 512-byte data blocks per DOWNLOAD MICROCODE command for mode 03h	F	0001h
235	Maximum number of 512-byte data blocks per DOWNLOAD MICROCODE command for mode 03h	F	1000h
236-254	Reserved		0000h
255	Integrity Word Bit 15-8: Checksum Bit 7-0: Checksum Validity Indicator	V	B8A5h

4.4 Set Features (EFh)

The Set Features command enables or disables the features listed in the following table:

FUNCTION	FEATURES REGISTER	SECTOR COUNT REGISTER
Enable read look-ahead ¹	AAh	Don't care
Disable read look-ahead ¹	55h	Don't care
Enable write cache ¹	02h	Don't care
Disable write cache ¹	82h	Don't care
Set Transfer Mode	03h	Don't care
Enable use of Serial ATA Feature	10h	02h-DMA Setup FIS Auto-Activate optimization 03h-Device-initiated interface power state transitions 06h-Software Settings Preservation
Disable use of Serial ATA Feature	90h	02h-DMA Setup FIS Auto-Activate optimization 03h-Device-initiated interface power state transitions 06h-Software Settings Preservation
Enable the PUIS feature set ¹	06h	Don't care
Disable the PUIS feature set ¹	86h	Don't care
PUIS feature set device spinup ¹	07h	Don't care
Enable/disable reverting to defaults ¹	66h	Don't care

¹ Changes are only valid while power remains applied to the drive. After power is cycled, the drive reverts to the default settings.

5.0 INSTALLATION AND SETUP PROCEDURES

Hard drives are precision instruments that must be handled with care to prevent damage. It is important to understand that drives are typically damaged due to electrostatic discharge (ESD), pressing on the top cover, rough handling, or shock and vibration.

Important: If your system does not support hot plugging (see “Hot Plug Support” on page 27), it must be turned off and unplugged before installing your hard drive.

5.1 Unpacking

5.1.1 Handling Precautions

HGST products are designed to withstand normal handling during unpacking and installation. Take care to avoid excessive mechanical shock, pressing on the top cover, or electrostatic discharge (ESD) which can permanently damage the hard drive and void the warranty. Hard drives are typically damaged because of ESD, rough handling, or shock and vibration.

Figure 5-1. Drive Handling Precautions

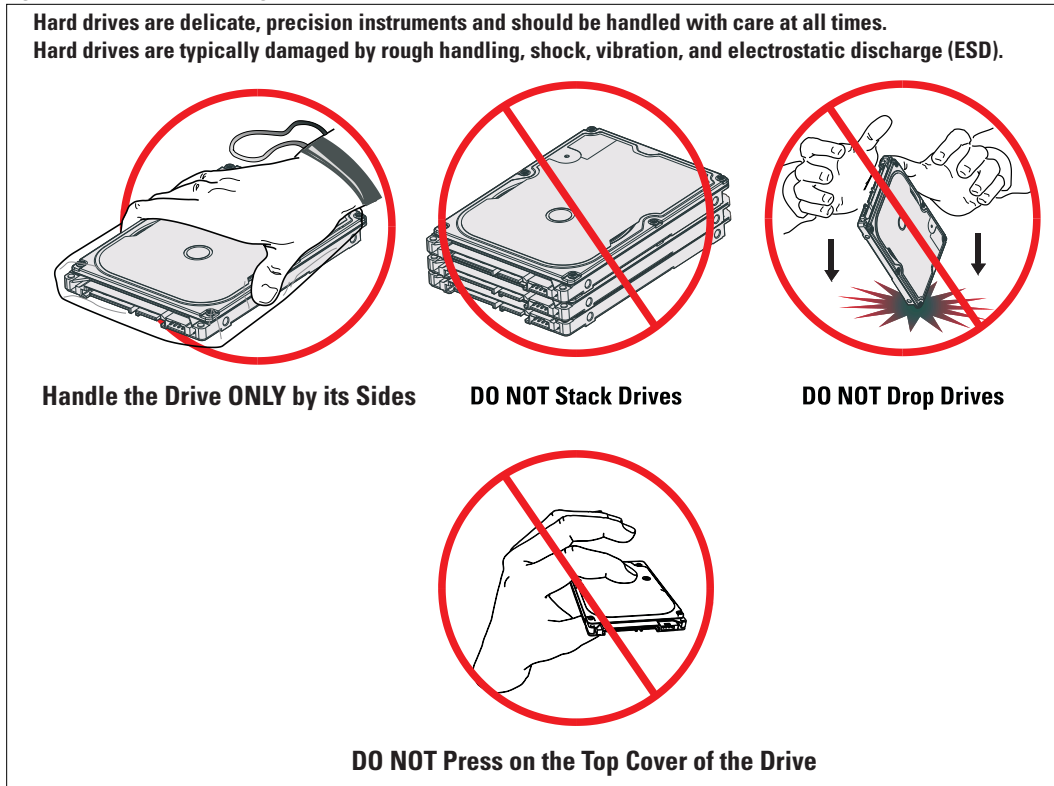

To avoid ESD problems, wear a properly grounded wrist strap when handling the hard drive. Articles of clothing generate static electricity. Do not allow clothing to come in direct contact with the hard drive or circuit board components.

When the drive is not in its shipping container or installed in its proper host enclosure, it must remain in the antistatic bag. To prevent damage, do not unpack your drive until you are ready to install it.

CAUTION: To avoid damage to internal drive components, do not apply a load greater than 2.6 lbf to a circular 10 mm diameter area anywhere on the top cover. Chassis design should allow for sufficient clearance and support to prevent loads from being transferred to the drive top cover.

5.1.2 Inspection of Shipping Container

Carefully examine the container for obvious shipping damage, such as: holes, signs of crushing, or stains. Notify the carrier and your HGST representative if you observe any shipment damage. Always move the shipping container in the upright position indicated by the arrows on the container.

5.1.3 Removal From Shipping Container

Remove the drive from the shipping container only for inspection or installation. Carefully open the box. When removing the drive from the box, follow these precautions:

- Grasp the drive by the sides only; avoid touching the circuit board components.
- Gently place the drive on its antistatic bag on a clean, level, grounded work area.
- Do not stack drives or stand the drive on its edge.

CAUTION: When removing the drive from the shipping container, be careful not to drop it. Dropping the drive can severely damage the head disk assembly or printed circuit board.

5.1.4 Removal From Static Shielding Bag

Before removing the drive from its static shielding bag:

- Make sure that your work station is properly grounded.
- Wear a properly grounded wrist strap with good skin contact.
- Avoid contact with any component on the printed circuit board.

Figure 5-2. Hard Drive Removal From Static Shielding Bag

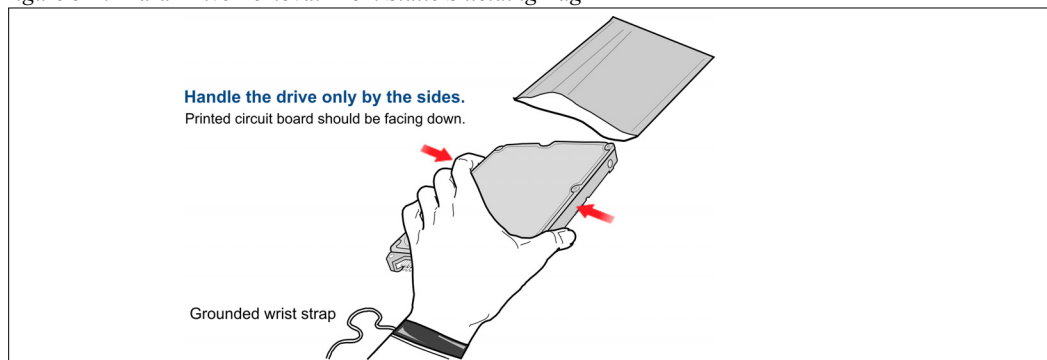

After attaching your wrist strap, gently remove the drive from the static shielding bag.

- Handle the drive by the sides only; avoid touching the printed circuit board.
- Handle the drive with the printed circuit board facing downward during installation.
- The unit should not be moved during drive activity.
- The unit is not intended as a portable device.
- Do not attempt to open the drive and service it yourself. Removing the cover may expose you

to harmful electrical voltages and will void the warranty.

- To allow ventilation, do not block the air slots on the underside and rear of the enclosure.
- Do not remove the tape seal or any labels from the drive; this will void the warranty.

5.1.5 Moving Precautions

If you need to move your computer, turn off the power to automatically unload the heads. This helps protect the media and the heads from accidental damage due to vibration, moving, or shipping.

5.2 Mounting Restrictions

Important: Your system must be turned off and unplugged before installing your hard drive.

5.2.1 Orientation

You can mount the hard drive in the X, Y, or Z axis, depending upon the physical design of your system. For best results, mount the drive with all four screws grounded to the chassis. If all four screws are not used, see "Grounding" on page 51.

5.2.2 Screw Size Limitations

The hard drive should be mounted to the chassis using four M3 screws. Recommended screw torque is 5 in-lb. Maximum screw torque is 6 in-lb.

CAUTION: Screws that are too long can damage the hard drive. Hard drive screw penetration can differ between products depending upon hard drive design. HGST's minimum design criteria is to always meet the SFF 8201 industry standard specification. The industry standard as defined in the SFF 8201 specifies for Side Mounting a maximum of 3 mm screw penetration, and a minimum of 3 threads engagement; and for Bottom Mounting a maximum of 2.5 mm screw penetration, and a minimum of 2.5 threads engagement.

5.2.3 Grounding

The PCBA and HDA grounds are always connected together in the drive and cannot be disconnected.

The drive mounting screws, unless intentionally isolated, will provide additional ground connections between the HDA and the system chassis.

When mounting the drive in a chassis or system, the chassis or system should never contact the crosshatched area "E" to prevent electrical shorting of the PCBA or drive. Contact should be limited to the side mounting (A, B, C, and D) or top facing mounting (1, 2, 3, and 4).

Figure 5-3. Grounding Diagram

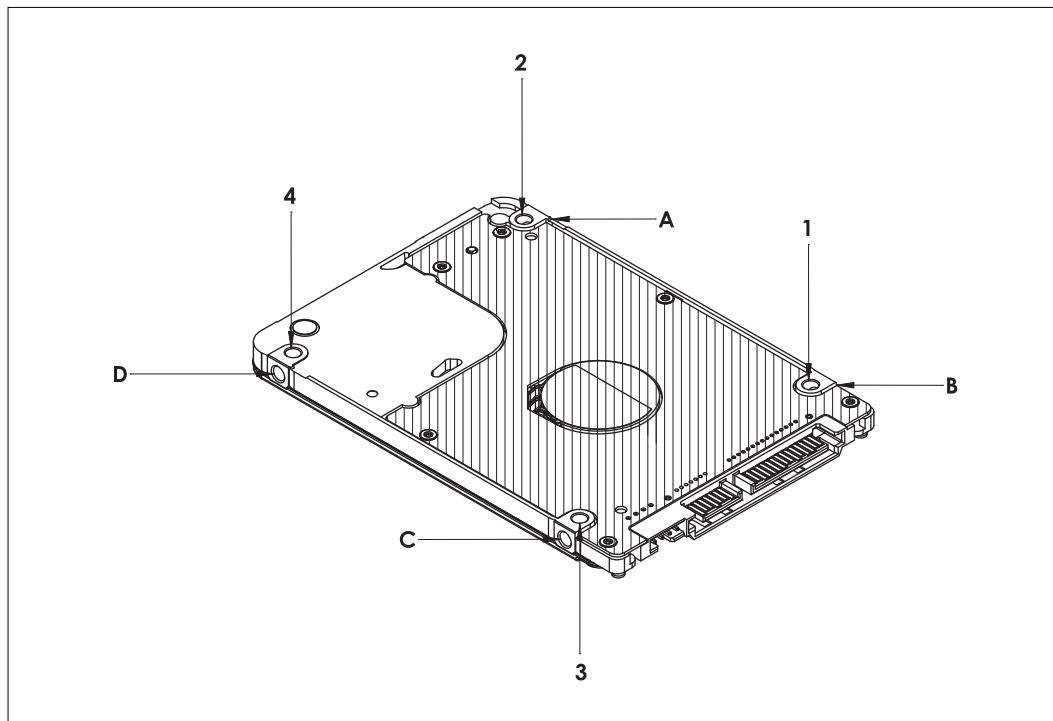

Side Mounting – Use four metal screws in A, B, C, and D. If less than four screws are used, remove in this order: C, D, and then B. You must use a screw in position A.

Top face Mounting–Use four metal screws in 1, 2, 3 and 4. If less than four screws are used, remove in this order: 2, 4, and then 3. You must use a screw in position 1.

5.3 Jumper Settings

It is not necessary to put a jumper shunt on the drive for notebook use. Advanced settings for the drive are as follows:

SSC Mode – Spread spectrum clocking feature. Default setting is disabled.

RPS Mode – RPS feature. Default setting is disabled

Figure 5-4. Jumper Settings

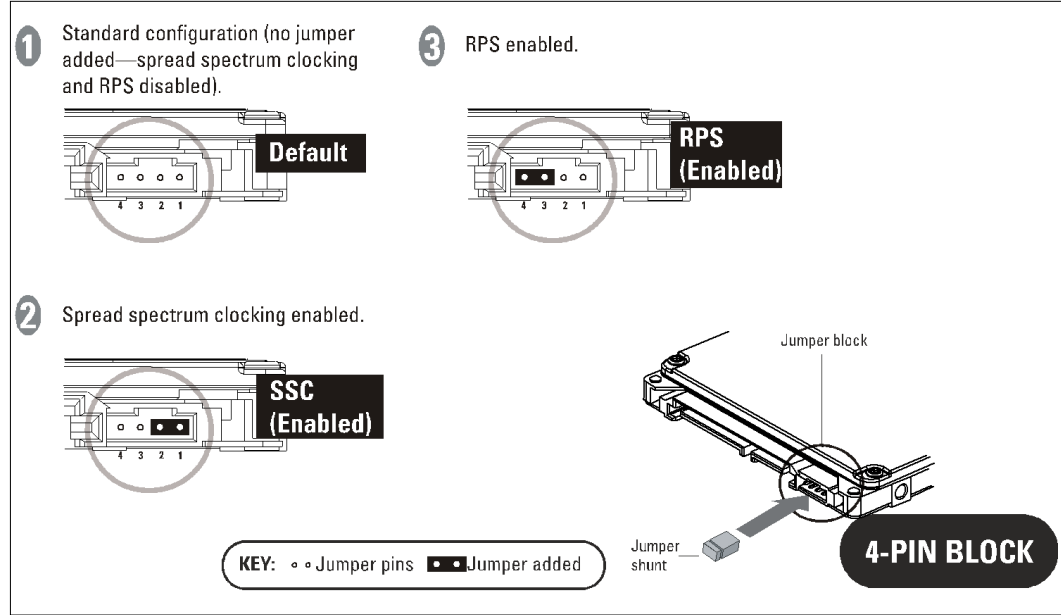

6.0 MAINTENANCE

The hard drive requires no preventative maintenance and contains no user-serviceable parts. The service and repair of HGST drives can only be performed at a HGST Service Center. Please contact your HGST representative for warranty information and service/return procedures.

Observe the following precautions to prolong the life of the drive:

- Do not attempt to open the sealed compartment of the HGST drive as this will void the warranty.
- Do not lift a HGST drive by the printed circuit board.
- Avoid static discharge when handling a HGST drive.
- Avoid harsh shocks or vibrations.
- Do not touch the components on the printed circuit board.
- Do not obstruct or cover any holes on the drive's cover. Air must be able to pass through these holes to the external air filter for normal operation of the drive.
- Observe the environmental limits specified for this product.
- If it becomes necessary to move your computer system, turn off the power to automatically unload the heads. This helps protect the media and the heads from accidental damage due to vibration while moving or shipping.
- To protect your data, back it up regularly. HGST assumes no responsibility for loss of data. For information about back-up and restore procedures, consult your operating system manual. There are also a number of utility programs available that you can use to back up your data.

7.0 GLOSSARY

Active LED Status - HGST SATA drives support external LED requirements. It provides an activity LED output which is ON during command execution and OFF otherwise.

Advanced Format Technology — Technology adopted by HGST and other drive manufacturers to increase media format efficiencies, thus enabling larger drive capacities.

Annualized Failure Rate (AFR) - A method of measuring failure rates or trends for a group of units at a site. The rates are based on the monthly total number of returned field failure units divided by the total cumulative installed base and multiplied by 12 (to annualize the failure rate).

ATA-8 Streaming Commands - The industry standard ATA-8 streaming command set enhances streaming performance in personal video recorders and other CE devices.

Automatic Defect Retirement - If defective sectors are found during a read or write, they are automatically mapped out and relocated.

Block - A group of bytes handled, stored, and accessed as a logical data unit, such as an individual file record.

Buffer - A temporary data storage area that compensates for a difference in data transfer rates and/or data processing rates between sender and receiver.

Data Lifeguard™ — Representing HGST's ongoing commitment to data protection, Data Lifeguard data protection utilities include thermal management, an environmental protection system, and embedded error detection and repair features that automatically detect, isolate, and repair problem areas that may develop over the extended use of the hard drive.

Data Transfer Rate -The rate that digital data is transferred from one point to another, expressed in bits per second or bytes per second.

- Data Transfer Rate to Disk: The internal disk transfer rate in Mbits per second.
- Data Transfer Rate from the Buffer to the Host: Based on the transfer of buffered data in MB per second.

Defect Management -A general methodology of eliminating data errors on a recording surface by mapping out known bad areas of the media.

Dynamic Fly Height Control — This feature is designed to compensate for head/media separation changes due to temperature and altitude. It adds video quality margins across temperature and altitude changes.

ECC On-the-Fly -A hardware correction technique that corrects errors in the read buffer prior to host transfer without any performance penalties. These error corrections are invisible to the host system because they do not require assistance from the drive's firmware.

Error Correction Code (ECC) -A mathematical algorithm that can detect and correct errors in a data field by adding check bits to the original data.

F.I.T. (Functional Integrity Testing) - A suite of tests HGST performs on all its drive products to ensure compatibility with different hosts, operating systems, application programs, and peripherals. This testing must be performed before the product can be released to manufacturing.

Fluid Dynamic Bearings (FDB) - Bearing design that incorporates a layer of high-viscosity lubricant instead of ball bearings in the hard drive spindle motor. As an alternative to conventional ball bearing technology, FDB designs provide increased non-operational shock resistance, speed control, and improved acoustics.

Formatted Capacity - The actual capacity available to store data in a mass storage device. The formatted capacity is the gross capacity minus the capacity taken up by the overhead data required for formatting the media.

Hot Plugging - The ability to swap out a failed hard drive without having to power down the system or reboot.

Latency - The period of time that the read/write heads wait for the disk to rotate the data to an accessible position. For a disk rotating at 5400 RPM, the average latency is 5.5 milliseconds.

Logical Address - A storage location address that may or may not relate directly to a physical location. The

logical address is usually used when requesting information from a controller. The controller performs a logical-to-physical address conversion and retrieves the data from a physical location in the storage device.

Logical Block Address - An alternative addressing methodology of identifying a given location on an SATA drive that permits disk sizes greater than 528 MB.

Perpendicular Magnetic Recording (PMR) - In PMR, the magnetization of each data bit is aligned vertically rather than longitudinally to the spinning disk. The adjacent bits attract instead of repel (as with bar magnets placed side by side), creating more thermally stable bits.

PRML (Partial Response Maximum Likelihood) - A read channel using sampled data, active equalization and Viterbi detection to accurately retrieve the user data off the disk.

Reduced Power Spinup (RPS) — HGST's optimized start up feature specifically designed for the external hard drive and Consumer Electronics (CE) market. Specific focus for RPS is to minimize the duration and magnitude of the peak power consumption from the hard drive.

RoHS (Restriction of Hazardous Substances) — HGST complies with the Restriction of Hazardous Substances (RoHS) Directive 2002/95/EC of the European Parliament, which is effective in the EU beginning July 1, 2006. RoHS aims to protect human health and the environment by restricting the use of certain hazardous substances in new equipment, and consists of restrictions on lead, mercury, cadmium, and other substances.

Rotational Latency - The amount of delay in obtaining information from a hard drive that can be attributed to the rotation of the disk.

RPM (Revolutions per Minute) - Rotational speed of the media (disk), also known as the spindle speed. Hard drives spin at one constant speed. The slower the RPM, the higher the mechanical latencies. Disk RPM is a critical component of hard drive performance because it directly impacts the rotational latency of the disk transfer rate.

Serial ATA (SATA) - SATA is the next generation bus interface for hard drives. It is designed to replace Parallel ATA, and has many advantages including increased transfer rate, improved signal integrity, enhanced data protection, and hot plugging.

Sector - A 512-byte packet of data.

Seek Time - The time it takes for the read/write head to move to a specific block of data on the hard drive. The average seek time is computed by dividing the time it takes to complete a large number of random seeks by the number of seeks performed.

Self-Monitoring, Analysis, and Reporting Technology (S.M.A.R.T.) - A technology to assist the user in preventing possible system down time due to hard drive failure.

SilkStream™ - Optimized for smooth, continuous digital video playback of up to twelve simultaneous HD streams. SilkStream is compatible with the ATA streaming command set so CE customers can use standard streaming management and error recovery options.

S.M.A.R.T. Command Transport (SCT) — The SCT Command Transport feature set provides a method for a host to send commands and data to a device and for a device to send data and status to a host using log pages.

System-on-Chip - The System-on-Chip (SOC) is the foundation for HGST's next generation electronics and firmware architecture. The native SATA SOC lowers component count by integrating a hard disk controller, high performance processor, high speed execution SRAM, and read channel in a 128-pin package.

Unrecoverable Error - A read error that cannot be overcome by an ECC scheme or by rereading the data when host retries are enabled.

Write Cache - A feature in CacheFlow that posts "command complete" prior to completing the actual write.

INDEX

—A—

Acoustics, 17, 20
Active LED Status, 27
Activity indication, 28
Advanced Formatting, 22
Agency Approvals, 20
Annualized Failure Rate, 55
ATA-7 streaming commands
 SilkStream, 22
 streaming commands, 22
Atmospheric Pressure, 17
Automatic Defect Retirement, 26

—B—

Buffer Size, 11
Bytes per Sector, 12

—C—

CacheFlow, 28
Commands
 SCT, 33
Cooling, 17
 Airflow, 17
Current Requirements, 14

—D—

Data Lifeguard, 24
Data Surfaces, 12
Data Transfer Rate, 11
Defect Management, 26
Device Plug Connector Pin Definitions, 19
Dimensions, 12

—E—

Error Rate, 11
Error Recovery Process, 26
ESD, 14

—F—

Fluid Dynamic Bearings (FDB), 27
Full Stroke Seek, 11

—G—

Glossary, 55
Grounding, 51

—H—

Host Interface Commands, 31
 Identify Drive, 37
 S.M.A.R.T., 33
 Set Features, 48
Hot Plug Support, 27

—I—

Input Voltage Requirements, 14
Installation and Setup, 49
Internal Environmental Protection System, 25

—J—

Jumper Settings, 52
 Jumper Settings Diagram, 53

—L—

Latency, 11
LED
 active status, 27
 activity indication, 28
Load/unload cycles, 11
Logical Block Addressing
 48-bit, 29

—M—

Maintenance, 54
Model number specification, 20
Mounting Restrictions
 Orientation, 51
 Screw Size Limitations, 51

—P—

Perpendicular Magnetic Recording (PMR), 23
Power Conservation, 29
Power Dissipation, 14, 16

—R—

Read Cache, 28
Recording Method, 12
Reduced Power Spinup (RPS), 23
Reliability features set, 24
Ripple, 14
RoHS (Restriction of Hazardous Substances), 17
Rotational Speed, 11

—S—

S.M.A.R.T., 29
S.M.A.R.T. Command Transport (SCT), 23
SATA 1.5 Gb/s, 22
SATA 3 Gb/s, 22
SCT, 23
SCT commands, 33
SCT feature set
 temperature reporting, 24
 write same, 24
Security Mode, 29
 Passwords, 29
 Security Levels, 30
Seek Time, 11
Shock, 15
SilkStream, 22

- Specifications, 11
 - Electrical, 14
 - Environmental, 15
 - Mechanical, 13
 - Performance, 11
 - Physical, 12
 - Reliability, 18
- Spindle Start Time, 11
- Staggered Spinup, 27
- System-on-Chip (SOC), 23

—T—

- Temperature
 - airflow, 17
 - cooling, 17
 - thermocouple location, 16
- Temperature and Humidity, 16
- Thermal Management, 25
- Thermocouple location, 16

—U—

- Unpacking
 - Container Inspection, 50
 - Drive Removal - Container, 50
 - Drive Removal - Static Shielding Bag, 50
 - Handling Precautions, 49
 - Moving Precautions, 51
- User Sectors per Drive, 12

—V—

- Vibration, 15

—W—

- Write Cache, 28

