

# EK-Quantum Vector RX 6800/6900 Backplate

BACKPLATE

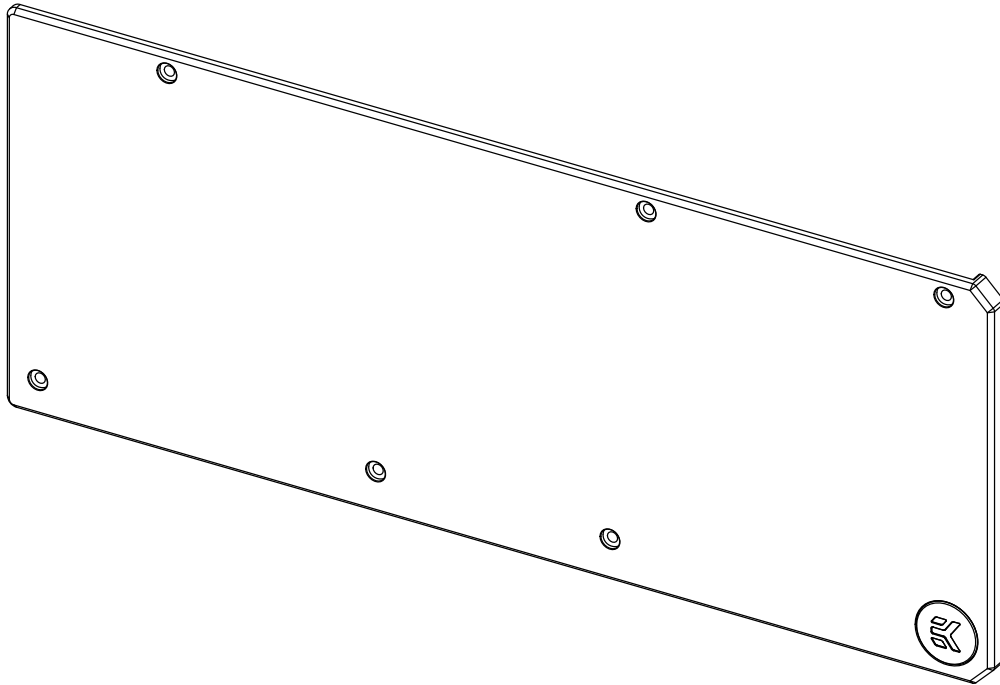

This product is intended for installation by expert users only. Please consult with a qualified technician. Improper installation may result in damage to your equipment. EK assumes no liability whatsoever, expressed or implied, for the use of this product or its installation. The following instructions are subject to change without notice. Please, read the manual carefully before beginning with the installation process. For updates, you can visit our official website **[www.ekwb.com](http://www.ekwb.com)**.

Before you start using this product, please follow these basic guidelines:

**Carefully read the manual before beginning with the installation process.**

**Remove your graphics card from the computer for the safest mounting process, to prevent any possible damage to your GPU or its circuit board (PCB).**

# TABLE OF CONTENTS

<b>BOX CONTENTS</b> .....	<b>4</b>
<b>BACKPLATE DIMENSIONS</b> .....	<b>5</b>
<b>REQUIRED TOOLS</b> .....	<b>5</b>
<b>INSTALLING THE BACKPLATE</b> .....	<b>6</b>
PREPARING THE GRAPHICS CARD.....	6
CUTTING AND PLACING THERMAL PADS.....	6
ATTACHING THE BACKPLATE.....	7
<b>TESTING THE LOOP</b> .....	<b>8</b>
<b>WARRANTY</b> .....	<b>8</b>
<b>SUPPORT AND SERVICE</b> .....	<b>9</b>
<b>SOCIAL MEDIA</b> .....	<b>9</b>

## BOX CONTENTS

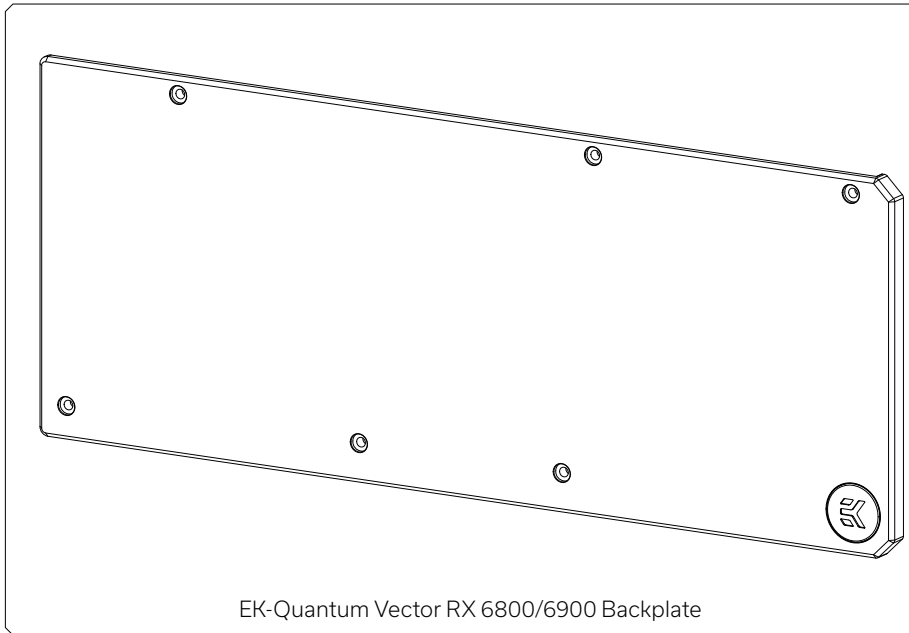

**Universal Mounting Mechanism** - You may not need every screw from this package.

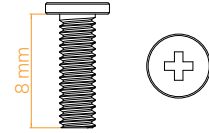

M2.5x8 AX1 Screw (8 pcs)

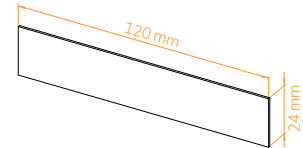

Thermal PAD G 1.5 mm - (120x24mm) (2 pc)

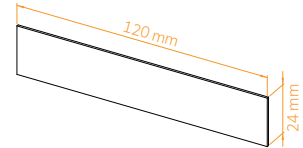

Thermal PAD G 2.0 mm - (120x24mm) (1 pcs)

## BACKPLATE DIMENSIONS

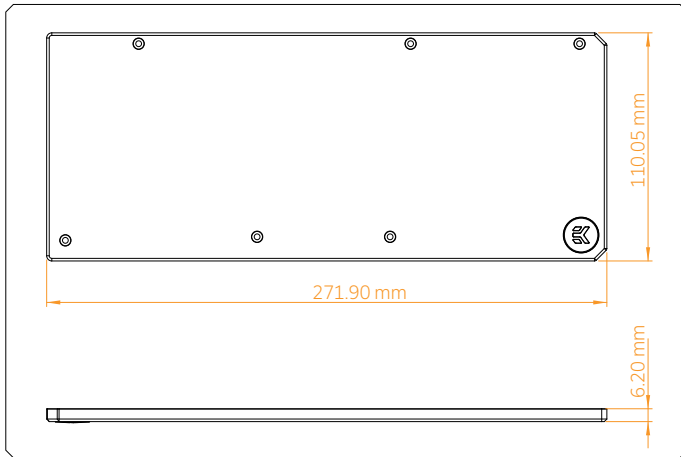

## REQUIRED TOOLS

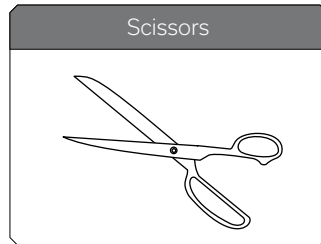
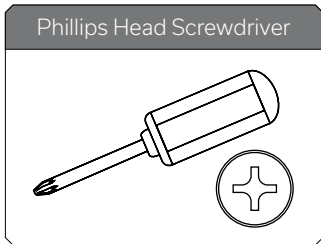

## INSTALLING THE BACKPLATE

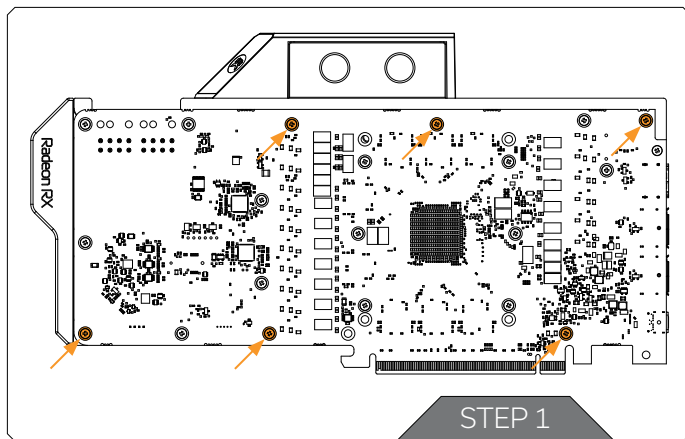

### STEP 1

#### PREPARING THE GRAPHICS CARD

First, complete the installation of your EK-Quantum Vector RX 6800/6900 water block according to its installation manual.

In case the water block is already installed, remove the six (6) AX1 screws and their PVC washers, as shown in the image.



### STEP 2

#### CUTTING AND PLACING THERMAL PADS

Your backplate comes with thermal pads that have to be cut into smaller pieces to cover all the VRM components. EK made sure to provide you with more than an adequate quantity of thermal pads to complete this Step.



**CAUTION:** You must remove the protective foil from both sides of the thermal pad before installation.

Replacement thermal pads:

2x Thermal PAD G 1,5 mm - (120 x 24 mm) - EAN: 3830046996749

1x Thermal PAD G 2,0 mm - (120 x 24 mm) - EAN: 3830046996756

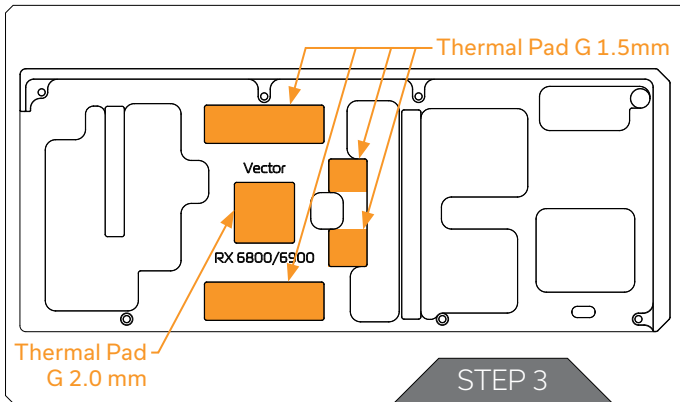

### STEP 3

Once cut to size, thermal pads should be placed on the backplate, as illustrated below.

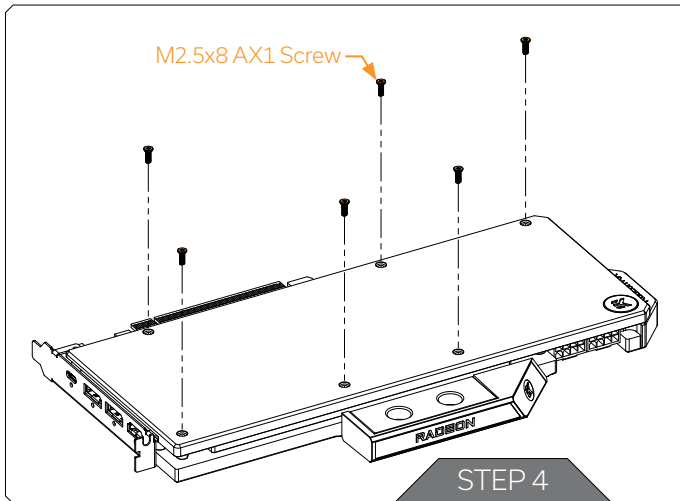

### STEP 4

#### ATTACHING THE BACKPLATE

Place the backplate on the PCB and make sure all holes are aligned. Position an M2.5x8 AX1 screw in each of the six (6) mounting holes (as shown in the image) and tighten them evenly with a Phillips head screwdriver. **Do not use excessive force!**

For this Step, you will need:

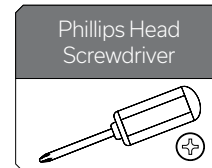

Phillips Head  
Screwdriver

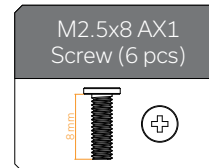

M2.5x8 AX1  
Screw (6 pcs)

## TESTING THE LOOP

To ensure the installation of EK components was successful, we recommend you perform a 24-hour leak test.

When your loop is complete and filled with coolant, connect the pump to a PSU outside your system. Do not connect power to any of the other components. Turn on the PSU and let the pump run continuously.

Inspect all parts of the loop, and in case the coolant leaks, fix the issue and repeat the testing process. To prevent possible damage, please ensure that all hardware is dry before the system is powered on.

## WARRANTY

Our products are warranted against defects of materials and quality for a period of 24 months, starting with the date of delivery to the end-user. During this period, products will be repaired or have parts replaced at our discretion, provided that 1) the product is returned to the agent from whom it was purchased; 2) the product has been purchased by the end-user and has not been used for commercial purposes; 3) the product has not been misused, handled carelessly, or used in a manner other than the way described in the instructions manual. This warranty does not confer rights other than those expressly set out above and does not cover any claims for consequential loss or damage. This warranty is offered as an extra benefit and does not affect your statutory rights as a consumer. This warranty is voided if the product comes in contact with aggressive UV additives or other improper liquids. EK water blocks are sealed with a warranty-voiding circular label, proving the water block has withstood a pressure leak test. Removing the label will void the leak-free guarantee, but not the guarantee on the product itself. Any other RMA issues can be reported to EK Customer Support at [www.ekwb.com/support](http://www.ekwb.com/support) for further analysis.



## SUPPORT AND SERVICE

In case you need assistance, please contact:

<http://support.ekwb.com/>

EKWB d.o.o.  
Pod lipami 18  
1218 Komenda  
Slovenia - EU

## SOCIAL MEDIA

 EKWaterBlocks

 @EKWaterBlocks

 ekwaterblocks

 EKWBofficial

 ekwaterblocks

