



1-800-846-9659

www.equalizersystems.com

AUTO-LEVEL™

&

Slide-Out

Forest River Georgetown
Operation and Warranty Guide



*Prepared Specifically For Forest River Owners
Effective February 2011*

Note: This Manual pertains to Systems using Pump # 3043 & Controller # 3055

TABLE OF CONTENTS

| | |
|---|-------|
| Precaution / Warnings | 2 |
| AUTO-LEVEL™ System Operation | 3-5 |
| Helpful Hints | 6 |
| Maintenance | 6 |
| Slide-Out Operation..... | 7 |
| Manual Override Procedures | 7-8 |
| Wiring and Hose Connection Guides | 9-10 |
| Troubleshooting | 11-13 |
| Equalizer Systems Warranty | 14 |

Important Warnings and Precautions

WARNING

READ ENTIRE INSTRUCTIONS AND ALL PRECAUTIONS PRIOR TO INSTALLING, USING, OR TROUBLESHOOTING THIS EQUIPMENT



- The system operates using hydraulic fluid under high pressure. Extreme fluid pressure can be present even if the system is not operating. System forces and pressures can cause severe injury or death if used improperly or modified. Service work should only be performed by trained technicians.
- Do not attempt to operate any portion of the hydraulic systems when the vehicle is in motion.
- Visually confirm that all leveling jacks are retracted prior to travel.
- Make sure there are no obstructions in the extend or retract paths of the jacks or slide-outs.
- Do not use the leveling jacks to lift the unit to perform any kind of service work or to change tires. The system is designed as a leveling and stabilizing system and is not meant to lift the coach off the ground.
- Do not go under vehicle when leveling jacks are extended.
- Do not operate any system functions while anyone is under the coach.
- Do not allow excessive motion in the coach during the AUTO-LEVEL™ operation. This could cause the system to level improperly.
- Modification of any factory-supplied item may result in the denial of all warranty claims. Call Equalizer Systems Technical Support prior to any modifications.
- Do not attempt any technical repairs without first consulting the troubleshooting guide in this manual and/or calling Equalizer Systems Technical Support at 1-800-845-9659. Failure to do so may result in denial of warranty claims.

AUTO-LEVEL™ Operation Guide

Controller # 3055 and Keypad # 3012

Manual Operation

- **Ignition Key On / Engine Run Position and Power On, Park Brake Applied:** Press and release the POWER keypad button to engage power. The LED in the POWER button should be lit RED when power is on. You need to have the ignition key in the On / Engine On Position to extend the jacks.
Park Brake Must Be Applied. It is Recommended to have the Engine Running to Insure proper Battery Voltage.

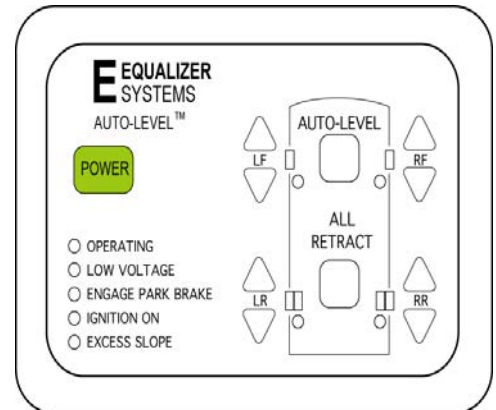

- **Planting the Jacks:** Using the DOWN ▼ Keypad Button, Extend each Jack until they contact the ground (this is referred to as “Planting” the Jacks). As you extend the first jack, All (4) of the Jacks Down LED Lights will come On and Flash. This is Normal, it only Indicates that the Jack (s) are not in Their Stowed Position. Jacks may be operated individually or in pairs. **Do not Manually Over Extend Individual Jacks. This may cause unwanted stress on the Coach or the Jacks.**
- **Leveling the Coach:** Use a bubble level on a flat surface in the center of the coach as a reference. Level the vehicle by using DOWN ▼ or UP ▲ keypad buttons until the vehicle is level. Jacks may be operated individually or in pairs as long as they are operated in the same direction. Do not attempt to lift the vehicle off the tires. Once level, Press and release the POWER button. Note: The keypad may be left on once level has been achieved. The keypad will enter “sleep mode” after five minutes of inactivity.

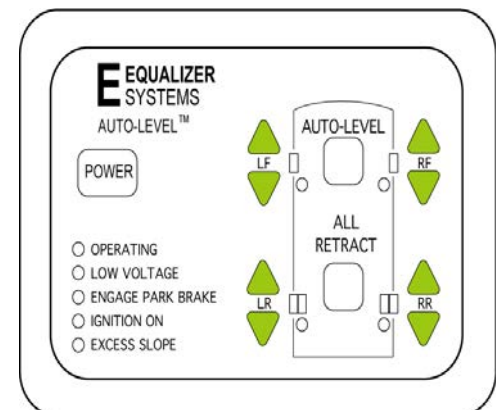

Power OFF: Turn Ignition Key Off, The Panel can now be Turned Off

- **Retracting the Jacks:** To retract Jacks, Press and Release the ALL RETRACT button. All jacks will automatically retract and return to stowed position. The pump will run in retract mode until all of the jacks are fully stowed (plus an additional 5 seconds) up to a maximum of 60 seconds. You may stop the ALL RETRACT by pressing any button on the keypad. An individual jack can be retracted by using the UP ▲ button for each individual jack. The Jack (s) Down LED Light Can Not be turned Off by using the Manual Up Buttons, The All Retract Button Must be used to Fully Stow the Jacks and Turn Off the Jack (s) Down Led Lights. **It is Recommended to have the Engine Running to Insure proper Battery Voltage.**

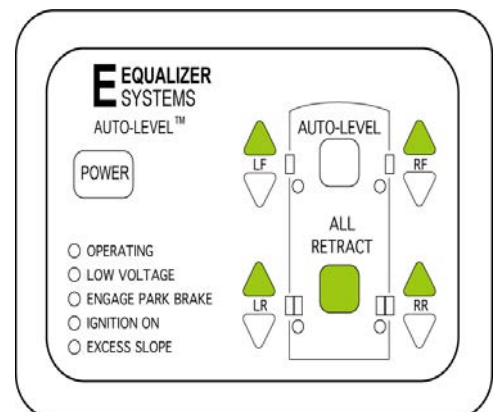

Visually confirm All Jacks are Retracted prior to Travel.
When the Key is turned On / Engine Running, Park Brake Released, An Auto Retract Mode will Start, If the Controller Believes the Jacks are Not Stowed. This is An Added Safety.
It is Not to be “Relied On” for Proper Retaction , Before Traveling.

- **Note:** There are Specific Instances when Manual Extension of one (or more) jacks is inhibited (Deny Tone when down is depressed). This Situation is caused by the “anti-twist” protocol in the software in the control box. Simply stated, the ‘anti-twist’ protocol denies jack extension if the system senses that a specific corner of the coach is approximately 3 degrees higher than the rest. You will be able to extend other jacks to over come the slope. If the system incorrectly senses excessive slope, this can be over come by resetting the Null. This will allow manual extension of all jacks. **Remember to re-set the Null after Manually Leveling the Coach.**

- **Setting the Null:** The Null or “Level Position” has been preset from the Factory. However, if the coach is not level following an attempt to AUTO-LEVEL™, the Null is easy to reprogram. To set the Null, Apply Park Brake, Turn the Ignition Key On, push and release the Keypad POWER Button to engage power. The POWER Button and Ignition On (LED’s), should be lit RED when power is on. Level the coach by deploying jacks manually (using the DOWN ▼ keypad buttons, extend each jack until the coach is level), or by simply parking the coach on a Level Site. You do not need to have jacks deployed to set the Null. Use a bubble level on a flat surface in the center of the coach as a reference. Once the coach is leveled, turn the Ignition Key Off and the Panel can now be turned Off. Now Depress and hold the AUTO-LEVEL™ Button, Continue to hold the AUTO-LEVEL™ Button and then press and release the POWER button, Listen for a Series of Beeps. After the panel has beeped 5 to 6 seconds, release the AUTO-LEVEL™ button (the keypad will continue to beep as long as the AUTO-LEVEL™ Button is held). The New Null Setting has been set and the panel will maintain this setting. Press and release the ALL RETRACT Button to retract the jacks to the Stowed / Travel position.

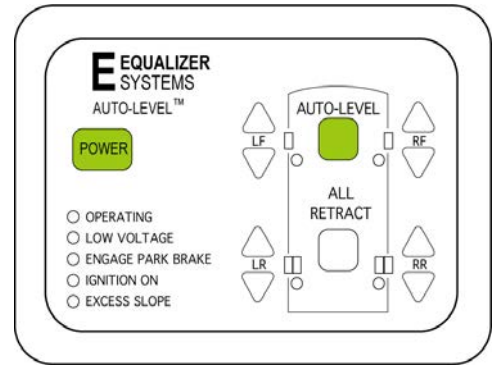

Automatic AUTO-LEVEL™ Operation

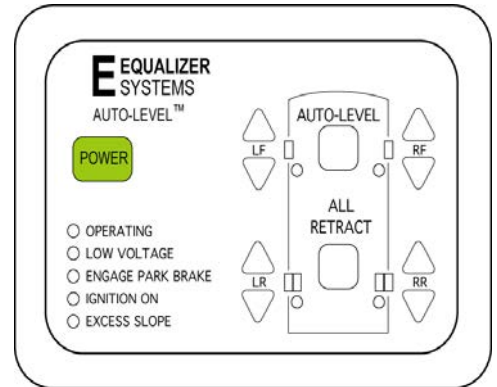

- **Ignition Key On / Engine Run Position, Park Brake Applied, Power On:** Push and release the POWER button to engage power. The LED light in the POWER button and Ignition On should be lit, when power is on. You will need to have the ignition key in the On / Engine Run position to extend the jacks. **It is Recommended to have the Engine Running to Insure Proper Battery Voltage.**
- **AUTO-LEVEL™:** Press the AUTO-LEVEL™ button and release. The system will send out a continuous series of beeps, the ‘OPERATING’ LED will flash RED to let you know AUTO-LEVEL™ is operating and will Automatically Level the Coach, the Jacks Down LED Lights will come on. When completed, the keypad will signal a successful level with a dual-level tone. Press and release the POWER button. Note: The keypad may be left on once level has been achieved. The keypad will enter “sleep mode” after five minutes of inactivity. **Ignition On light should be lit when the Key is Turned On.**

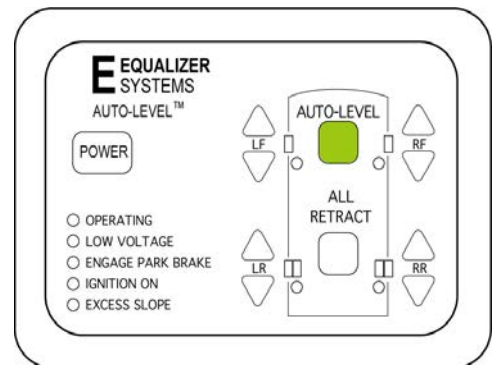

Power OFF: Turn Ignition Key Off, The Panel can now be Turned Off

- **Retracting the Jacks: Turn Ignition Key On / Engine Run Position:** The Equalizer System provides the ability to retract the jacks using the ALL RETRACT button or the UP/ Down button for each individual jack. All jacks will automatically retract and return to stowed position when the ALL RETRACT button is pressed and released. The pump will run in retract mode until all of the jacks are fully stowed (plus an additional 5 seconds) up to a maximum of 60 seconds. You may stop the ALL RETRACT by pressing any button on the keypad. The Jack (s) Down LED Light Can Not be turned Off by using the Manual Up Buttons, The All Retract Button Must be used to Fully Stow the Jacks and Turn Off the Jack (s) Down Led Lights. **It is Recommended to have the Engine Running to Insure proper Battery Voltage.**

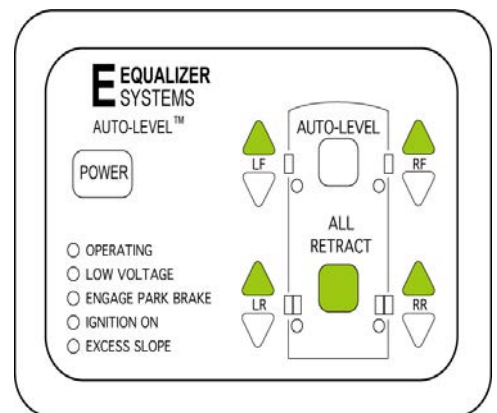

Visually confirm all jacks are retracted prior to travel.
When the Ignition Key is turned On / Engine Running, Park Brake Released, An Auto Retract Mode will Start, If the Controller Believes the Jacks are Not Stowed. This is An Added Safety. It is Not to be “Relied On” for Proper Retaction , Before Traveling.

Keypad Indicator LED's

There are ten (10) LED indicators on the AUTO-LEVEL™ Keypad. The functions of these LED's are detailed below.

During Typical Operation, the LED Lights that should lit are the 'OPERATING' LED, and "Ignition On" LED

- 'POWER' LEDON Red when power is ON
OFF when power is OFF
FLASH every 5 sec. In Sleep Mode
- 'JACK' LED (4 each) ON Red when jack(s) are deployed
OFF when jack(s) are stowed
- 'OPERATING' LEDFLASHING Red w/ Auto Level or All Retract
OFF when keypad is idle or 'sleeping'
- 'LOW VOLTAGE' LED ON Red when Voltage is below 10.5 volts DC
OFF when Voltage is above 10.5 volts DC
- 'ENGAGE PARK BRAKE' LED ON Red when Park Brake is Not Applied
OFF when Park Brake is Applied
- 'IGNITION ON' LEDON Red when Ignition is in the ON position
OFF when Ignition is OFF
- 'EXCESS SLOPE' LED ON Red following an Auto Level attempted, if
system cannot overcome slope
OFF when slope is not excessive

If the LOW VOLTAGE, ENGAGE PARK BRAKE, EXCESS SLOPE LED's are illuminate, an 'error' condition is present and must be corrected prior to operating the jacks.

Note: To Extend Jacks Down in Auto Level or Manual Mode, the following needs to be Present, Ignition Key On / Engine Run Position, "Ignition On" LED Lit. Park Brake MUST Be Applied, "Park Brake" LED Off.

It is Recommended to have the Engine Running to Insure Proper Battery Voltage

Note: If the Jacks are Not Fully Retracted (Jack Down LED Light On) The Keypad Can Not be Turned Off, if the Ignition Key is in the On / Engine Run Position.

Helpful Hints

- If your coach is equipped with air suspension, it is recommended that the coach be started / running and chassis air pressure allowed to build before pressing ALL RETRACT. This will ensure adequate air supply to the chassis air valves.
- Your system may be equipped with a manual override option (consult vehicle manufacturer). Refer to the Manual Override section of this manual for the proper procedure. It is usually better to review this procedure prior to its actual use, rather than having to learn a new procedure in difficult environments.
- You may allow any automatic function to run for the entire programmed time (and stop automatically), or you may stop the action by pressing any button on the keypad.
- To ensure proper leveling, do not move around in the coach during the AUTO-LEVEL™ process. Leveling may be unsuccessful if motion is present.
- AUTO-LEVEL™ is a microprocessor-controlled system. Proper and adequate battery voltage and permanent chassis ground are essential.
- Operate jacks first, then slide-outs
- When operating slide-outs, the Jacks Down indicator lights may illuminate.

Maintenance

- Maintain the reservoir level to a minimum of 3/4 full with Dexron III Transmission fluid, with All Slide-outs and Jacks Retracted
- Change fluid if the reservoir shows signs of contamination: debris or water.
- If the vehicle is parked in an extremely hot and/or humid environment with jacks and slide-outs extended for long periods (over 30 days), spray the cylinder rods with WD40 to prevent corrosion.
- The slide-out mechanisms are designed to operate without added lubrication. Greases and oils can trap and collect dirt that can lead to premature wear. If desired, a coating of WD40 or silicone spray can be applied to the mechanism to prevent rust. Wipe off any excess.
- Proper maintenance of the vehicles electrical system is important for proper system operation. Proper voltage and grounding is critical. Follow the battery manufacturer's guidelines regarding battery care and maintenance.

Slide-Out Operation

Park and level the unit prior to extending the slide-outs. To prepare for travel, retract the slide-outs prior to retracting the leveling jacks.

Slide rooms will operate with the ignition key in the 'OFF' position ONLY.

To **EXTEND** the Slide-Out rooms:

Press and hold the OUT / EXTEND button. Hold the button until the room reaches the end of its travel

To **RETRACT** the Slide-Out rooms:

Press and hold the IN / RETRACT button. Hold the button until the room reaches the end of its travel

Note: Slide-Out systems are designed to fully run through each extension or retraction cycle. Make every effort to fully extend or fully retract a slide-out room each time it is operated. Changing the direction of slide-out movement when the room is in a position other than either fully extended or fully retracted may result in uneven operation of the room.

When retracting rooms, a delay may be present until the hydraulic pump builds enough pressure to retract the room. Just continue to press the switch until the room retracts.

Low voltage at the pump assembly can cause erratic operation of the slide-out rooms. Be sure to keep batteries fully charged to prevent erratic operation.

When operating slide-outs, the Jacks Down indicator lights may illuminate. The same hydraulic pump assembly powers both the slide-out and leveling systems. If the leveling control panel is turned ON with the jacks retracted, extending the slide-outs may cause the JACKS DOWN LED to illuminate.

If the Slide-Out is a cable Support and Timing Mechanism for the Main Slide Room, It was manufactured by Norco Industries in Elkhart Indiana. The Cylinders and Under Room Supports are Supplied by Equalizer Systems. This portion of the slide-out mechanism should not require maintenance during the normal life of the vehicle. The component parts of the slide-out mechanism carry a 1 year limited warranty through the final stage manufacturer. If questions arise regarding the function of this mechanism, please refer to the Norco Industries web site at www.norcoind.com or call the service department (800) 347-2232.

Manual Override Procedures

If Electrical Power is lost to the Leveling or Slide-Out System, your system has been equipped with a Manual override Option.

Bi-Rotational Pump # 3043 Shown

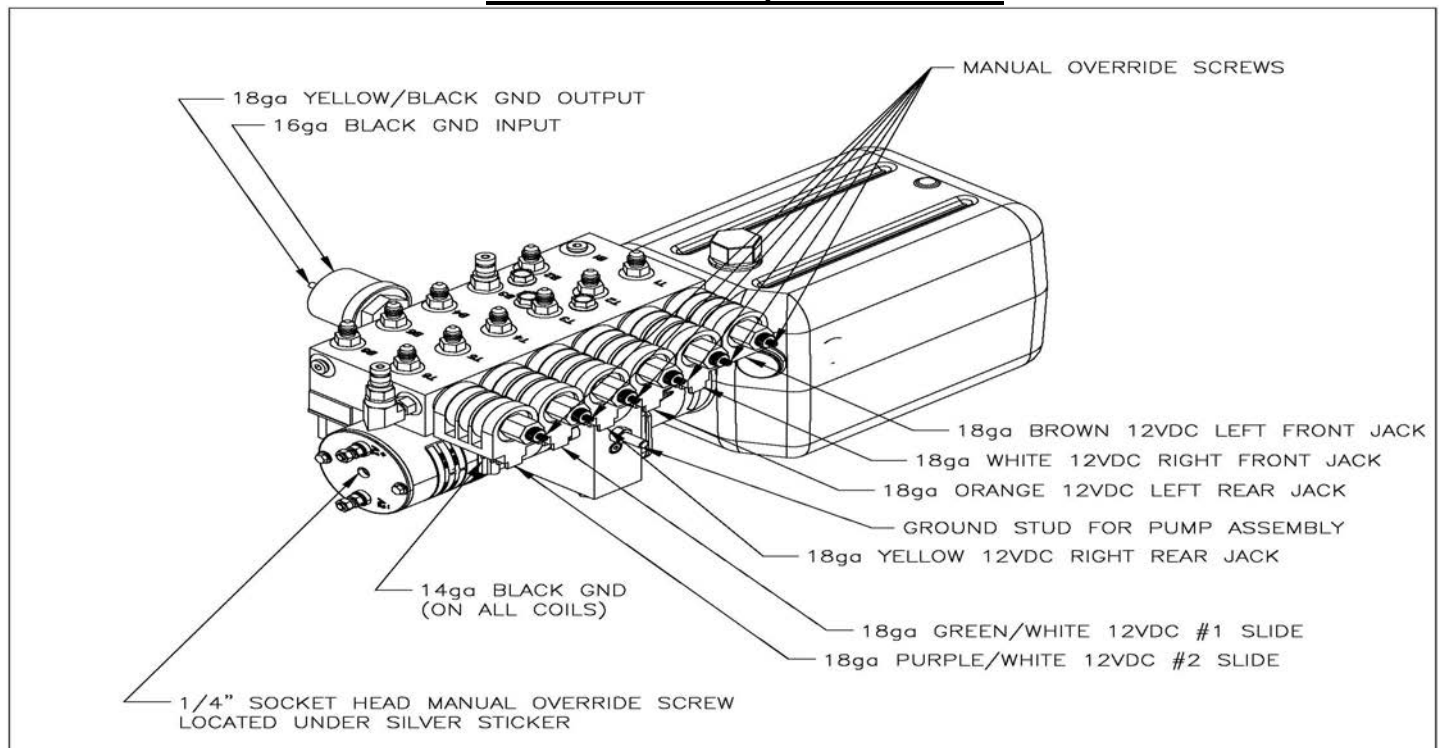

To Manually Override (bi-rotational pump assembly): Pump #'s 2390, 2532, 2542, 3043

The individual cartridge valves are clustered together on the side of the pump manifold. Valves for leveling jacks are labeled 1 thru 4. See the hose connection section in the Operations Manual to identify the valves for slide-out functions. Locate the screws on the appropriate cartridge valve(s). Using a Small Flat Blade Screwdriver, or an Allen Wrench, turn the screw (s) clockwise, all the way in and lightly seated (approx 2.5 turns). An individual slide-out room or leveling jack can be manually overridden by only opening the valve associated with that function.

- 1) Access the manual override coupler: Remove the Black Plastic Cap or Silver (Foil) Seal, from the end of the motor (use a small flat head screwdriver). Place a drill (2000 rpm minimum) equipped with a 1/4 " (6mm) Allen Drive Socket or 7/16" (11mm) Hex Socket on the manual override coupler. Care Must be taken to ensure that the drill and socket don't contact any wires or hoses.
- 2) **If Equipped, Open the DV2 Valve.**
To identify a pump equipped with a **DV2 Valve**, examine the manifold above the motor. **DV2** is a solenoid operated cartridge valve with a red knurled knob or an Allen Screw.
To Open: Pull out on the red knob and turn ¼ turn by hand (either direction), Or Screw the Allen Screw In (clockwise). The valve should lock in the out/open position.

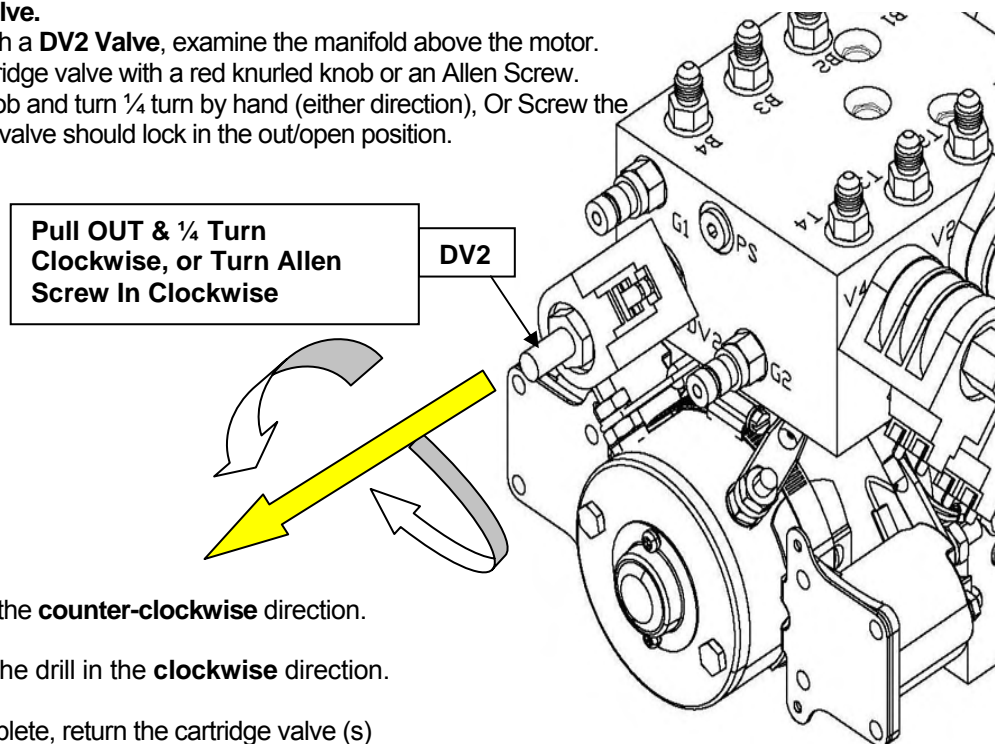

- 3) To **Retract** your jack(s) run the drill in the **counter-clockwise** direction.
- 4) To **Extend** your jack(s), run the drill in the **clockwise** direction.
- 5) When Manual Override is complete, return the cartridge valve (s) And DV2 (if equipped) to the Normal Positions.
Reinstall Black Plastic Cap / Silver (Foil) Seal on motor.

***** **Caution** *****

Following manual override operation, return all valves to normal operational position. Failure to do so may result in drifting from the retracted (stowed) position of slide-outs or leveling jacks. Cartridge valves: Rotate the center screw fully counter-clockwise until lightly seated. DV2: Turn the red knob and allow the valve handle to snap IN or Closed. Operate DV2 by hand only- NO TOOLS!

Valve Identification/Hose Connections

| Valve #- Function | Hose Label Color- Extend | Hose Label Color- Retract | Cartridge Valve Wire Color |
|--------------------------------|--------------------------|---------------------------|----------------------------|
| V1= Left Front Leveling Jack | Brown | Brown w/ stripes | Brown |
| V2= Right Front Leveling Jack | White | White w/ stripes | White |
| V3= Left Rear Leveling Jack | Orange | Orange w/ stripes | Orange |
| V4= Right Rear Leveling Jack | Yellow | Yellow w/ stripes | Yellow |
| V5= Slide-Out #1 (if equipped) | Green | Green w/ stripes | Green |
| V6= Slide-Out #2 (if equipped) | Purple | Purple w/ stripes | Purple |
| V7= Slide-Out #3 (if equipped) | Grey | Grey w/ stripes | Grey |
| V8= Slide-Out #4 (if equipped) | Red | Red w/ stripes | Red |

Pump Wiring- pump #'s 2390, 2532, 2542

HYDRAULIC PUMP FUNCTION WIRING

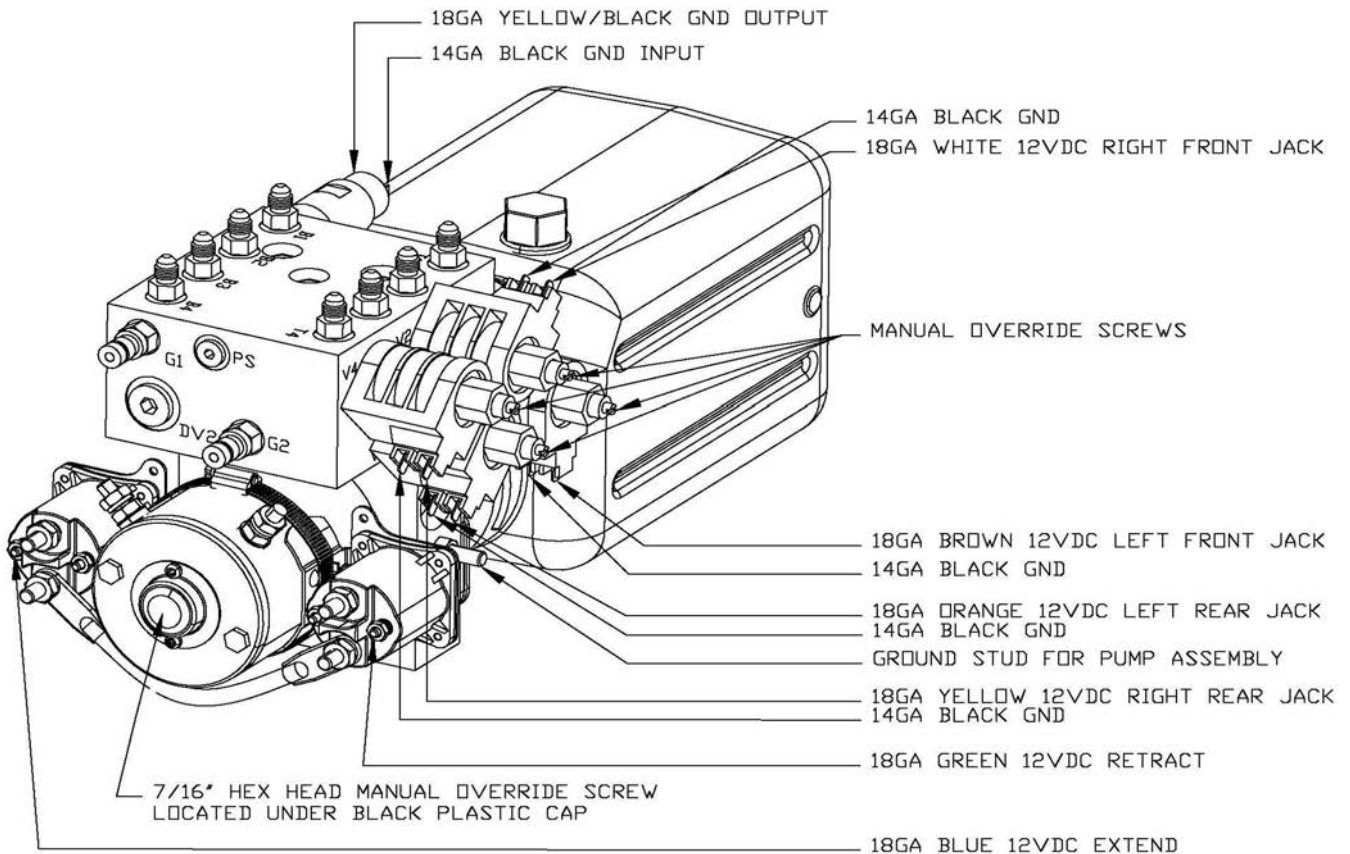

Assembly Wiring

Solenoid Wiring Bi-Rot Pump #'s 2390, 2532, 2542

BIROTATIONAL WIRING CONFIGURATION

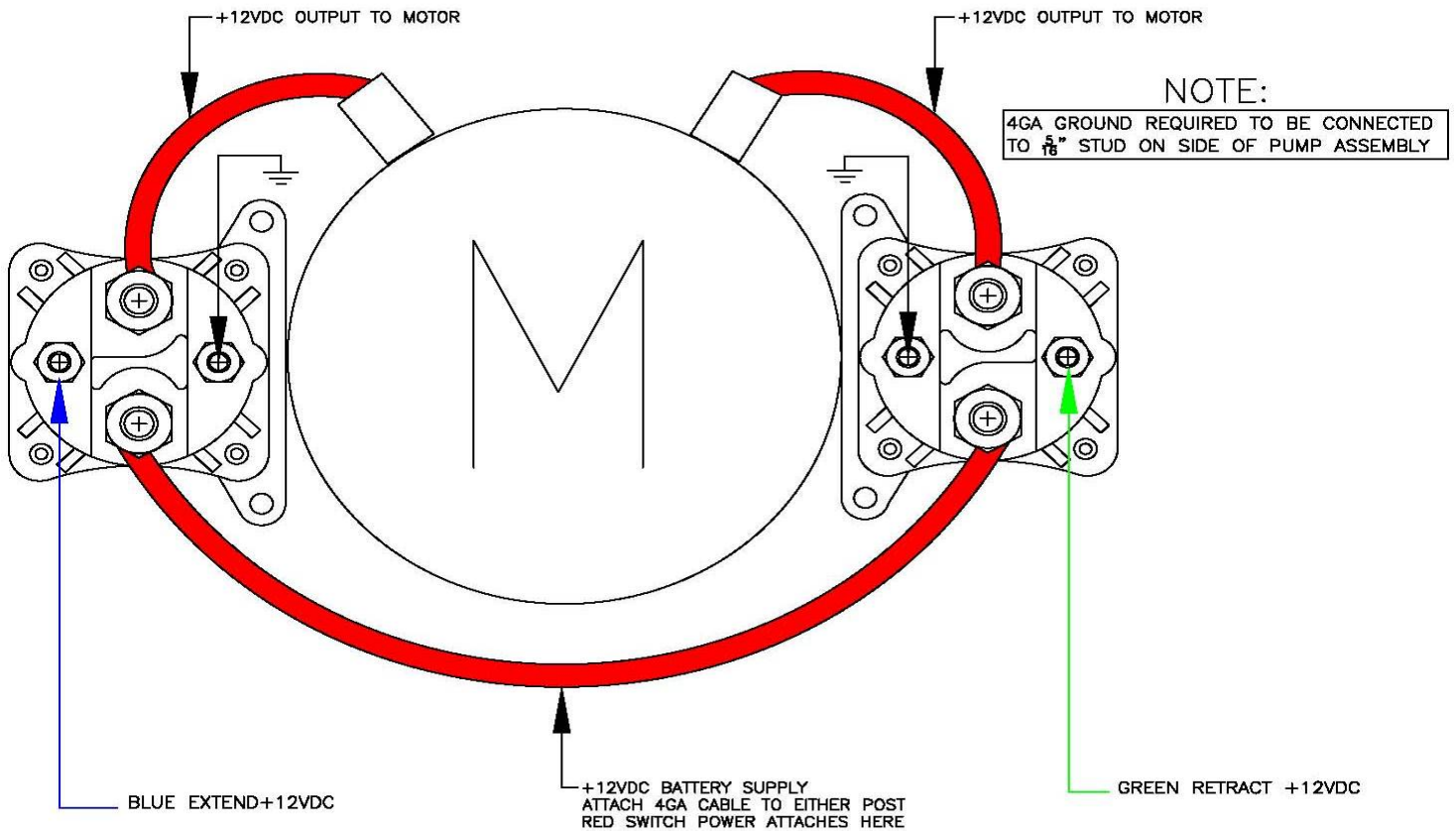

Wiring for Pump # 3043

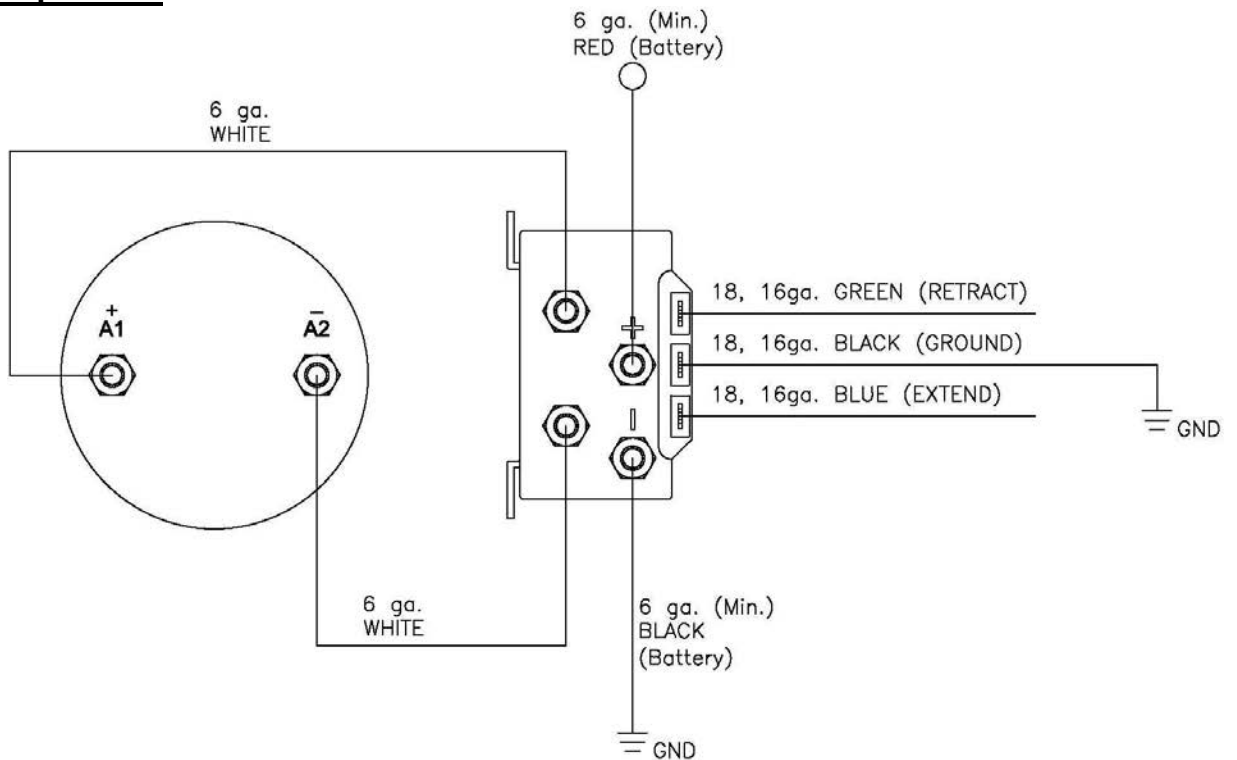

Troubleshooting Guide

Symptom

Possible Cause

Corrective Action

| | | |
|--|---|---|
| Keypad will not turn on | Blown fuse at pump harness or in fuse panel | Replace fuse |
| | Faulty ground or power wire | Trace and repair |
| | Low Battery Voltage | Charge chassis and/or coach batteries |
| | Defective Keypad or Controller | Call Equalizer Tech Support |
| | Defective Keypad harness | Trace and repair |
| Keypad turns on – Jacks will not operate | Low Battery Voltage to Pump | Charge chassis and/or coach batteries |
| | Faulty electrical connection | Trace and repair |
| | Defective Keypad or Controller | Call Equalizer Tech Support |
| | Defective pump motor or solenoid | Replace |
| | Other system defect | Call Equalizer Tech Support |
| Jacks will retract but will not extend | Low Battery Voltage to Pump | Charge chassis and/or coach batteries |
| | Park Brake not set | Set park brake |
| | System Null not set | Set Null |
| | Anti-Twist Software Protocol has been Initiated | Lower opposite side of coach and/or Re-set Null and Level Coach |
| | Ignition Switch in wrong position | Check and change as needed |
| | Defective Keypad or Controller | Call Equalizer Tech Support |
| | Faulty electrical connection | Trace and repair |
| | System Defect | Call Equalizer Tech Support |

Troubleshooting Guide

| Symptom | Possible Cause | Corrective Action |
|--|---|---------------------------------------|
| Jacks will extend but will not retract | Low battery voltage | Charge chassis and/or coach batteries |
| | Incorrect hose connection at pump or jack | Trace and repair |
| | DV1 --faulty wire or valve | Check and repair |
| | Defective Keypad or Controller | Call Equalizer Tech Support |
| AUTO-LEVEL™ will not level | System Null not set | Set Null |
| | Controller installed improperly or has moved | Check controller orientation |
| | Ignition Switch in wrong position | Check and change as needed |
| | Damaged or defective Keypad harness | Call Equalizer Tech Support |
| | Defective Keypad | Call Equalizer Tech Support |
| | Other System Defect | Call Equalizer Tech Support |
| AUTO-LEVEL™ stops mid-cycle | Low battery voltage | Charge chassis and/or coach batteries |
| | Excessive vehicle motion during leveling sequence | Reset Control Panel and re-try |
| | System Null not set | Set Null |
| | Damaged or defective Controller | Check and replace |
| | Damaged or defective Keypad harness | Call Equalizer Tech Support |
| | Other System Defect | Call Equalizer Tech Support |
| Jack LED's on panel stay on | Defective Pressure Switch or wiring | Trace and repair or replace |
| | Defective Keypad Harness | Trace and repair or replace |
| | Defective Keypad | Call Equalizer Tech Support |

Troubleshooting Guide

| Symptom | Possible Cause | Corrective Action |
|---|--|---|
| Hydraulic pump inoperative | Low battery voltage | Charge chassis and/or coach batteries |
| | Blown fuse or breaker in fuse panel | Replace fuse or reset breaker |
| | Faulty electrical connection | Trace and repair |
| | Defective pump motor or solenoid | Replace |
| Jack(s) bleed down from leveled position or stowed position | Air in hydraulic system | Purge air |
| | External fluid leak | Trace and repair |
| | Defective valve in pump | Clean or replace valve |
| | Defective jack | Replace jack |
| Jack(s) are jerky when retracting | Air in the system | Purge air |
| | Fluid level low | Check fluid level and add as necessary |
| Jack(s) will not retract from full extension | Low Battery Voltage at Pump | Charge chassis and/or coach batteries |
| | Low battery voltage or poor ground to Keypad | Charge chassis and/or coach batteries and ensure proper grounding |
| | Damaged or defective harness from Keypad to pump | Trace and repair |
| | Fluid level low | Check fluid level and add as necessary |

Avoid the most common issues! Always ensure & verify proper charge on the batteries!

Proper and adequate grounding of the pump is essential!

90% of the phone calls we receive are found to be a discharged battery or poor ground!

**If your problem is not listed or persists, call
Equalizer Systems at 1-800-846-9659. EXT: 339
Please gain prior Authorization for Warranty Service or Repair.**



Equalizer Systems Limited Warranty Policy

1. Only warranty claims with prior written or verbal authorization from Equalizer Systems will be recognized, all other claims will be denied.
2. Equalizer Systems warrants slide out and leveling system components for a period of **two years** from the date of original sale of the vehicle. This warranty covers defects in material and workmanship only. Equalizer Systems is not liable for any damage due to abuse, neglect, misuse, negligence, misapplication, error of operation, accidental or purposeful damage or damage due to an "act of God" such as, wind or rain damage, flood, lightning or other natural occurrence of the like. Equalizer Systems limited warranty is applicable to the Equalizer Systems components only and does not apply to the vehicle, apparatus or property to which it is attached. Warranty parts will be shipped at no charge if the repair is authorized by an Equalizer Systems representative. Purchased components used in authorized warranty repairs will be reimbursed at the original purchase price.
3. Labor and freight expenses due to warrantable parts defects or workmanship will be reimbursed for a period of **one year** from the date of original sale of the vehicle. Freight expenses will either be prepaid by Equalizer Systems or reimbursed at the UPS Ground rate only. Any additional shipping charges or requirements are the obligation of the vehicle owner or service center performing the warranty repair. The owner or service center's obligation may include overseas shipping charges, border fees, brokerage fees and any other additional fee of the like.
4. Warranty labor will be reimbursed only for claims that have prior written or verbal authorization from an Equalizer Systems representative. Warranty labor compensation is required to correspond with the "Warranty Parts Replacement Time Guideline" published by Equalizer Systems. Any warranty repair not listed on this guideline will require prior authorization from an Equalizer Systems representative. A reasonable time allowance will be determined by the Equalizer Systems representative. Any warranty repair that is not listed on this guideline that is performed without prior authorization will be denied without exception. Time associated with learning about the repair or excessive diagnostic and installation time will not be reimbursed. Warranty labor will be reimbursed at the authorized service center's published shop rate if the rate is reasonable for that region. Overtime labor will not be reimbursed without exception.
5. Labor, parts and freight credit (if applicable) will be sent after the parts are tested and the warranty claim is validated. Returned parts that are found to be in normal operating condition are not warrantable and will be charged to the owner or service center. Equalizer Systems reserves the right to charge back the service center for labor claim payments previously submitted if the installation of the warranted part is found to be inadequate at a later date.
6. Claims will be denied if the date submitted is greater than 30 days from the repair date.
7. Prior authorization is required before parts may be sent back to Equalizer Systems. A Return Authorization Number is required for items to be accepted.
8. Complete systems are not warranted unless authorized by an Equalizer Systems representative. There are absolutely no exceptions to this clause.
9. Consideration should be taken regarding the location and protection of Equalizer Systems' components prior to installation. Please reference our installation manuals for recommended locations and maintenance, or visit www.equalizersystems.com for more information. The failure of any Equalizer Systems' component due to extreme environmental conditions, improper installation, or lack of maintenance will not be covered under warranty.
10. Warranty coverage for parts or systems sold by non-authorized resellers (such as live or internet auctions) will be at the discretion of Equalizer Systems.
11. This warranty begins upon the original sale date of the vehicle and is transferable, with limitation, to subsequent owners upon furnishing the original sale date of the vehicle and proof of purchase. Only the remainder of the two year parts warranty is applicable. Warranty labor and freight are only applicable to original owner of the vehicle.
12. Equalizer Systems is not liable for loss of time, manufacturing costs, labor, material, loss of profits, direct or indirect damages incurred by the vehicle manufacturer.
13. Excessive warranty labor resulting from inadequate access to the Equalizer Systems product will not be reimbursed.
14. Equalizer Systems will not pay a markup on warranty parts unless required by law.
15. Travel expenses, hotel, telephone, fuel or any other expenses of the like are not covered under warranty.

Replacement Parts:

1. Replacement parts are warranted under the same guidelines listed above for the remainder of the original warranty or 90 days, whichever is longer. Proof of warranty repair date and original vehicle purchase date are required.

No additional warranties, expressed or implied, are authorized by Equalizer Systems

This warranty voids all previous issues. Questions concerning this warranty should be directed to:

Equalizer Systems
P.O. Box 668
Elkhart, IN 46515
(800) 846-9659
(574) 266-6083 fax

Effective: January 1, 2010

800/846-9659

www.equalizersystems.com