



FRM-1010 Continuous Band Sealer Instruction Manual

Distributed By:

Version 2.9
Last Updated: 9/11/19

Copyright © 2013 by Stephanie Hwang

All rights reserved. No part of this publication may be reproduced, distributed, or transmitted in any form or by any means, including photocopying, recording, or other electronic or mechanical methods, without the prior written permission of the publisher, except in the case of brief quotations embodied in critical reviews and certain other noncommercial uses permitted by copyright law. For permission requests, write to the publisher, addressed "Attention: Permissions Coordinator," at the address below.

Sealer Sales, Inc.
8820 Baird Avenue
Northridge, Ca 91324
www.sealersales.com

Printed in the United States of America

General Information

Thank you for purchasing our FRM-1010 Impressé continuous band sealer.

This owner's manual contains information relating to your band sealer machine. The manual will provide you with basic information concerning both operation and maintenance of your new machine. Please read it carefully as failure to do so may result in bodily injury and/or damage to the equipment.

Please fill in the information below. You will find the information on the machine identification plate. You will need this information when ordering replacement parts or making technical inquiries.

No part of this manual may be duplicated, reproduced, stored in a retrieval system, translated, transcribed, or transmitted in any form without the express prior written permission of Sealer Sales.

FRM - 1010 EQUIPMENT INFORMATION

❖ Model #

❖ Serial #

❖ Purchase Date:

❖ Reference # (found on packing slip)

❖ Owner:

Table of Contents

Safety Instructions	1
Introduction.....	3
Operation	9
Maintenance.....	19
Parts Diagram.....	24
Troubleshooting.....	39
Spare Parts List.....	42
Quality Control Testing.....	43

Safety Instructions



WARNING! Below are general safety precautions and warnings that should be understood prior to setting up or operating your equipment. Read and fully understand all instructions and warnings prior to using this unit. Your safety is most important! Failure to comply with procedures may result in serious injury or property damage. Remember: **Your personal safety is your responsibility.**

Unsafe practices or unauthorized modifications could result in accidents or property damage. Failure to follow these safety rules and take necessary precautions can result in serious injury as well as damage to equipment.

- ❖ Never operate or service your band sealer until you have read this manual completely and understand it fully.
- ❖ Plug the band sealer into a standard 120 Volt, 60Hz wall outlet or surge protector. We highly suggest using a surge protector. Some special order units are 220 Volt, 50Hz. Make adjustments as necessary.
- ❖ Do not use the band sealer if the power cord, plug or any other parts are damaged. Be sure not to allow the power cord to drape into your work area. Check that all parts are operating properly and perform the intended functions. Check for all other conditions that may affect the operation.
- ❖ Reduce risk of unintentional starting. Make sure the power switch is in the "OFF" position before plugging into the power source.
- ❖ Always disconnect sealer from power source before servicing, changing accessories or cleaning the unit.
- ❖ To provide protection against the risk of electrical shock, the power connection must be properly grounded at all times.
- ❖ Do not leave the sealer unattended when in use. Disconnect the sealer from the power source before leaving the work area.
- ❖ Band sealer is used solely for sealing thermoplastic materials. Using the machine for any other purpose can cause damage to the machine and operator. Do NOT use the machine for any other purpose other than to seal thermoplastic materials. Doing so may result in damage to the machine and injury to the operator.
- ❖ Always operate machine on a flat stable surface.
- ❖ While operating machinery, wear close-fitting clothing and tie back long hair to prevent any external items from getting caught in the machine. Do not wear jewelry when operating the band sealer.

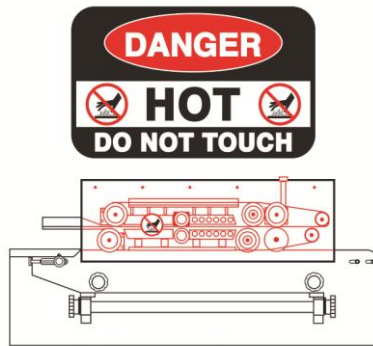

- ❖ While machine is operating do not touch the heating and/or cooling blocks. Blocks will be extremely hot and may burn your hands.



- ❖ While machine is in operation, do not place fingers, tools, or other foreign objects on or into the machine. Do not touch any moving parts while machine is operating. Fingers may get caught in between the gears / pinch points and cause significant injury.
- ❖ Thermoplastic bags and material are hand fed into the machine. Place bag on the guide and carefully feed the bag through the band sealer. Fingers may be placed on the guide but do not allow fingers to touch any of the moving parts on the band sealer.
- ❖ Use emergency stop to turn off machine should material/bags get jammed into the machine. Carefully pull material out of the band sealer. Do NOT use fingers to touch any part of the machine.
- ❖ The band sealer is not water resistant or water proof. Spraying down the machine will damage machine or cause electrical shock. Do not submerge the band sealer into water or liquid.
- ❖ Do not operate band sealer in a corrosive or humid environment.
- ❖ Always keep the machine clean, lubricated and in good working condition. Follow any maintenance and lubrication procedures outlined in this manual. Make sure unit is disconnected from power source before cleaning.
- ❖ NEVER use any accessories or parts from other manufacturers. Machine should not be altered or modified using parts that are not genuine authorized parts. Doing so will VOID YOUR WARRANTY.
- ❖ Never leave the band sealer unattended. Be safe, disconnect the band sealer from power source before leaving work area.
- ❖ Close supervision is necessary when any machine is near children or persons with reduced physical, sensory or mental capabilities or lack of experience and knowledge. This sealer is NOT to be used by children or by persons with reduced physical, sensory or mental capabilities or lack of experience and knowledge.
- ❖ DO NOT use the band sealer outdoors.
- ❖ DO NOT use the band sealer while under the influence of drugs, medications or alcohol.

SAVE THESE INSTRUCTIONS - REFER TO THEM OFTEN AND USE THEM TO INSTRUCT OTHERS.

Introduction

FRM-1010 is equipped with an electronic temperature controller and variable speed conveyor to seal all types of thermoplastic materials (PP, PE, stand up pouches, gusseted bags, moisture barrier bags, etc.). Seals are created using PTFE bands which maintain high seal quality and produce consistently strong, clean seals on all heat sealable bags. Because bags are placed on a conveyor system, the width of the bag does not matter. These versatile machines offer several adjustments which allow them to be used for a wide range of applications. These machines are used extensively in the food, medical, chemical, cosmetic, and electronic industries.

The FRM-1010 band sealer adopts dry ink coding designed to print date and lot codes at the seal line. Ink dries instantly upon contact with packaging materials and produces clear and legible characters. Standard font size is 18PT which allows for two-line printing. An optional 10.5PT font size which allows for three-line printing can be purchased separately. Please ask your distributor for more information.

There are two configurations for the FRM-1010 band sealer. The horizontal configuration (FRM-1010I) is primarily used for sealing dry materials and when you can lay flat your pouch. The vertical configuration (FRM-1010II) typically seals small solid products (ex: powders, grains, coffee) and liquids. In addition, sealing using the vertical configuration also works best with stand up pouches.

Features of the FRM-1010 Band Sealer

Your band sealer is equipped with a wide range of standard features and capabilities.

- ❖ Simple to use – minimal operator training
- ❖ Fast warm up time
- ❖ Unit feeds right to left
- ❖ Rust inhibiting stainless steel construction
- ❖ Equipped with bag entry guide for easy bag feeding and straight seals
- ❖ Control panel includes industrial grade safety emergency stop switch
- ❖ 10amp protection power surge breaker
- ❖ Equipped with photo sensor for optimal printing precision
- ❖ Dry ink coder for printing characters at the seal line
- ❖ Wide seal (15mm) to assure airtight seal / 20mm wide seal band sealer available via special order
- ❖ PTFE sealing belts
- ❖ NeXt Gen heating blocks - larger heating blocks for more efficient heat penetration
- ❖ Extended forced-air cooling system with extra wide cooling bars and 6 heat transfer orifices
- ❖ One pair of brass sealing bars
- ❖ Sealing method – constant heat
- ❖ Adjustable 2-way pulley system for optimal stability and embossing clarity
- ❖ Knurled pressure rolls with variable pressure adjustment
- ❖ PID digital temperature controller 0-300°C (572°F) with dual alphanumeric displays (target & current temp)

- ❖ Motorized rubber conveyor with speed control
- ❖ Capable of speeds up to 472 inches/minute

How Does the FRM-1010 Work?

Basic

Principles

FRM-1010 is easy to use. To seal, adjust temperature and place bag on conveyor

FRM-1010 is comprised of a stainless steel frame, speed adjusting mechanism, sealing temperature control system and transmission system. Turning on the heat for the band sealer will cause a rapid rise in the temperature of the heating blocks. Required temperature and speed can be adjusted via the temperature controller and speed adjusting device. Plastic material to be sealed is placed on the guide and conveyor. Conveyor will then take the material between the two heating blocks to fuse the material together. Material will then pass through the cooling blocks to allow the material to congeal. Material will then pass through the embossing wheel for a meshed seal line. Finally, a photoelectric sensor will direct the dry ink coder to print a clear and legible print at the seal line.

The motor drives the sealing belts, drive belts and conveyor simultaneously.

Specifications

	FRM-1010I (Horizontal)	FRM-1010II (Vertical)
Power	110V/60Hz	
Motor Power	60W	
Sealing Speed	0-472 inches/minutes	
Sealing Width	15mm (Optional 20mm width unit available via special order)	
Temperature Range	0-300°C (572°F)	
Conveyor Size	42" x 8"	
Max Conveyor Load	6.6lbs	
Min/Max Height of Bag (<i>Vertical Only</i>)	N/A	7.9" / 12.6"
Printing Heating Power	40 x 2 (W)	
Character Size	3x5x7mm / 18PT – 2 lines 2x3x7mm / 10.5PT – 3 lines (additional option available)	
Printing Colors	Black, Blue, Green, Red, White, Yellow	
Dimensions	42" x 18" x 14"	42" x 16" x 27"
Net Weight	119lbs	132lbs

FRM-1010 Diagram

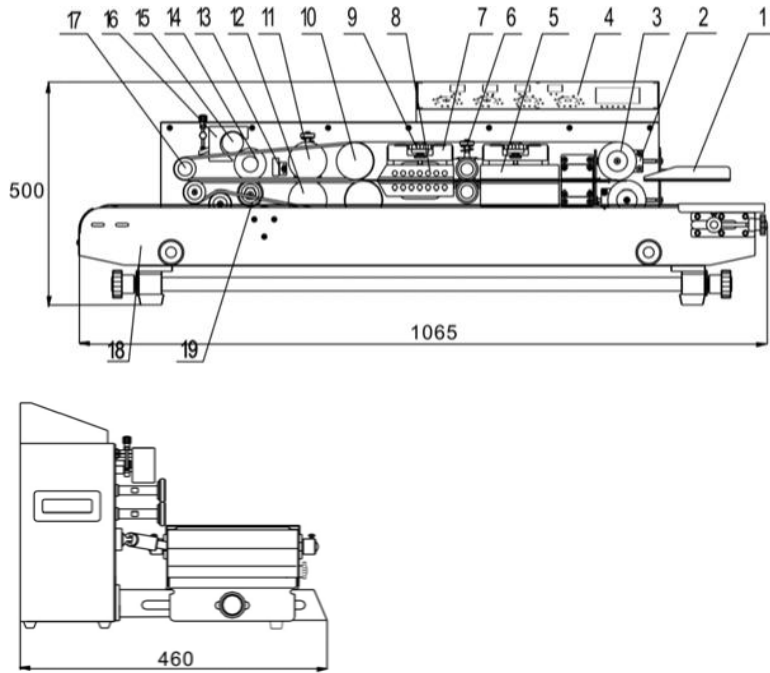

Figure 1. Horizontal Band Sealer - FRM-1010 (1) Guide, (2) Driven Wheel Seat (Adjusting Block), (3) Driven Wheel, (4) Control Panel, (5) Heating Block, (6) Pinch Roller (7) Heating/Cooling Block Seats, (8) Cooling Block, (9) Block Control Knob, (10) Driving Wheel (11) Embossing Wheel, (12) Silicone Wheel for Embossing (13) Photoelectric Sensor, (14) Printing Wheel, (15) Ink Roller, (16) Ink Roller Heating Block, (17) Guide Wheel (Small), (18) Conveyor Table, (19) Silicone Wheel

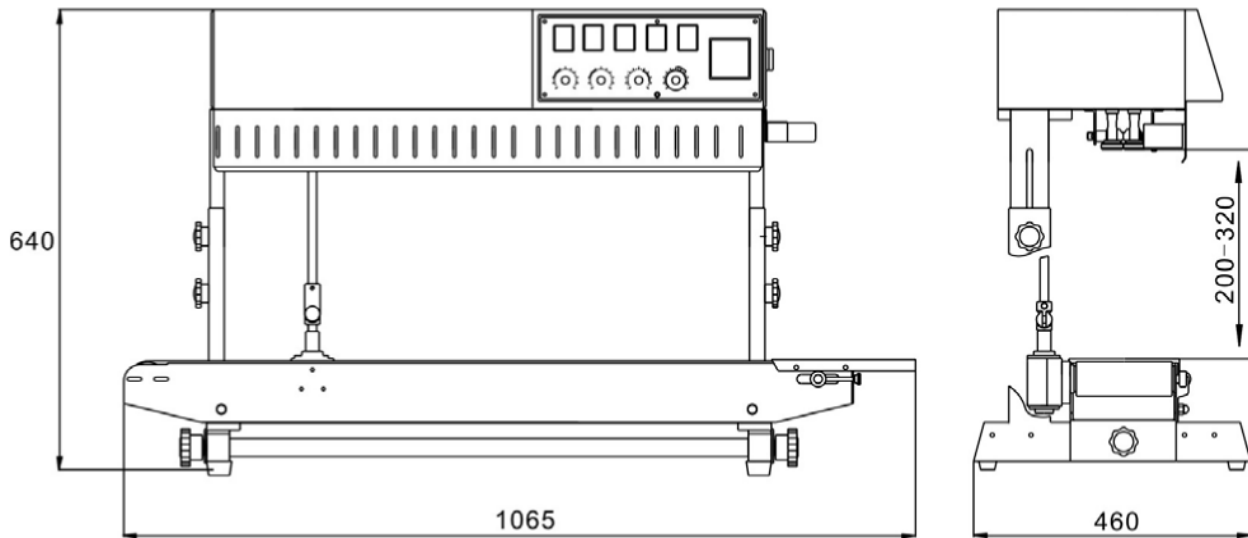

Figure 2. Vertical Band Sealer FRM-1010II

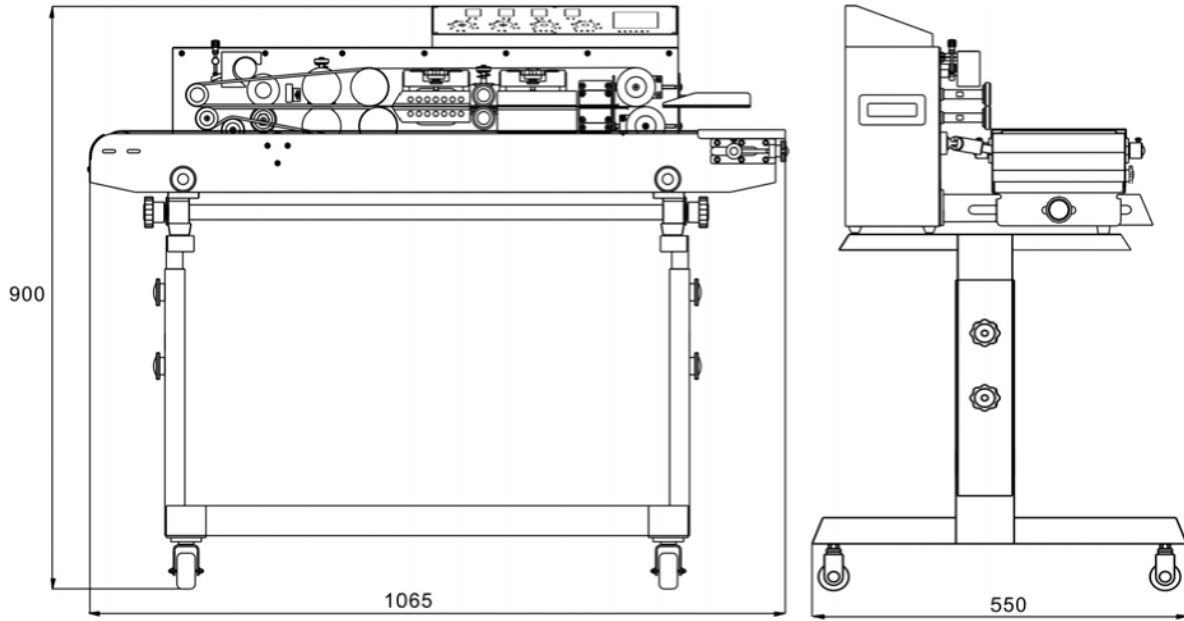
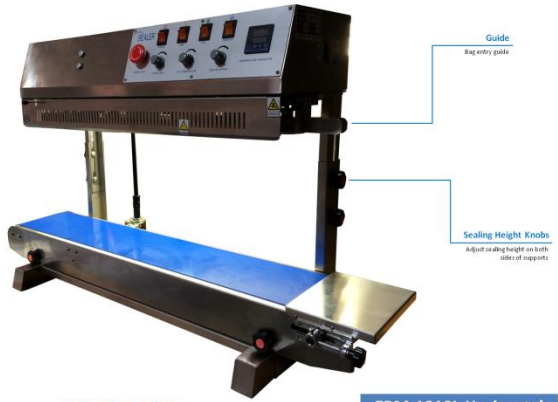

Figure 3. Horizontal Band Sealer with Stand. Optional stand available for FRM-1010. Please ask your distributor.

Getting to Know your Band Sealer

FRM-1010II - Vertical



FRM-1010I -Horizontal



Control Panel



Electrical Circuit Diagram

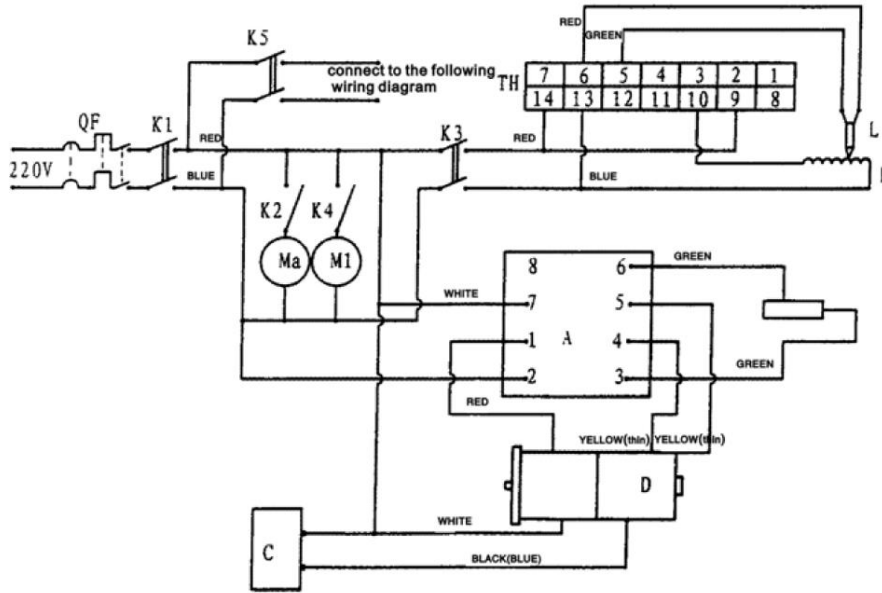

Figure 4. Electrical Circuit Diagram.

- | | | | |
|-------------------------------|-----------------------------|---------------------|--------------------------|
| QF - Switch/On/Off | K1 - Switch/Start | K2 - Switch/Fan | K3 - Switch/Heat Seal |
| K4 - Switch/Air Suction (N/A) | K5 - Switch/Printer | L - Thermocouple | Ma - AC Fan |
| M1 - Air Suction Pump (N/A) | Th - Temperature Controller | C - Capacitance | D - Variable Speed Motor |
| W - Potentiometer | R - Heating Element | A - Speed Regulator | |

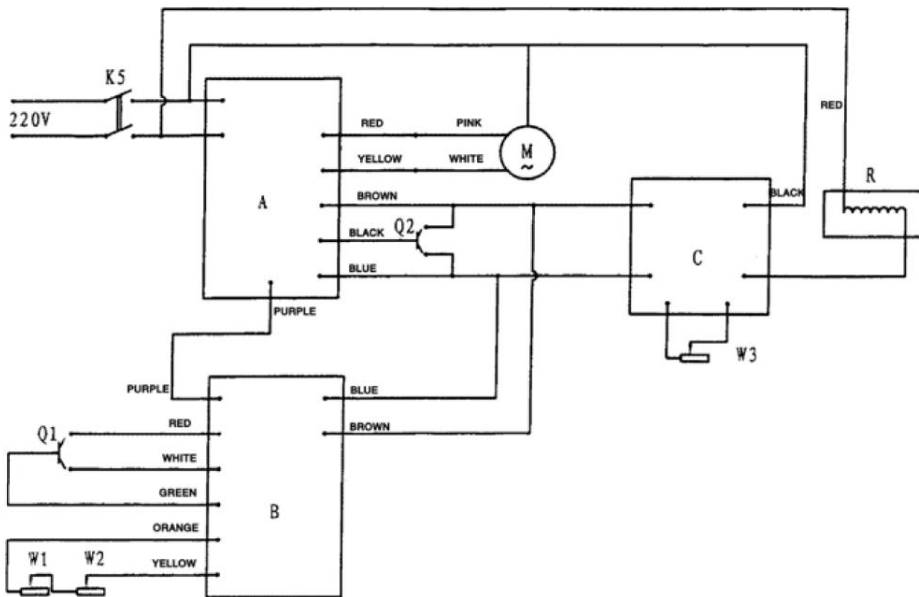

Figure 5. Electrical Circuit Diagram.

- | | | | |
|--|--|---------------------------|-----------------------|
| K5 - Switch/Printer | W1 - Speed Adjusting Potentiometer (fine tuning) | Q1 - Photoelectric Sensor | Q2 - Proximity Switch |
| W2 - Speed Adjusting Potentiometer (coarse tuning) | B - Auxiliary PCB | C - Heating PCB | R - Heating Element |
| A - Main Control PCB | M3 - Temperature Regulator | | |
| M - AC Motor | | | |

Operation

Operation Set-up

1. Our machines are equipped with a three-prong grounded plug. Make sure the plug is well-connected in the socket to ensure safe operation.
2. Make sure the circuit breaker is in the “ON” position. (Levers pointing up)
3. First time operation. Allow the machine to pre-heat by running at a low temperature for a few minutes. This would apply if the machine has not been in operation for a long time. The machine can sometimes be damp from storage or shipment and running at a low temperature will dry out any residual moisture.
4. For some materials, an adjustment to the clearance between the upper heating block and the bottom heating block may be necessary. The clearance can be adjusting by turning the block control knob (Figure 6, Item #1). Turning the knob clockwise will raise the upper heating block (increase the clearance) and turning the knob counter clockwise will lower the upper heating block (decrease the clearance). Similar adjustments should also be made with the cooling blocks. The clearance should be equal to the thickness of one layer of your material to be packaged. This will ensure high seal quality and embossing. ***Please note that the majority of materials sealed will NOT need adjustments.***

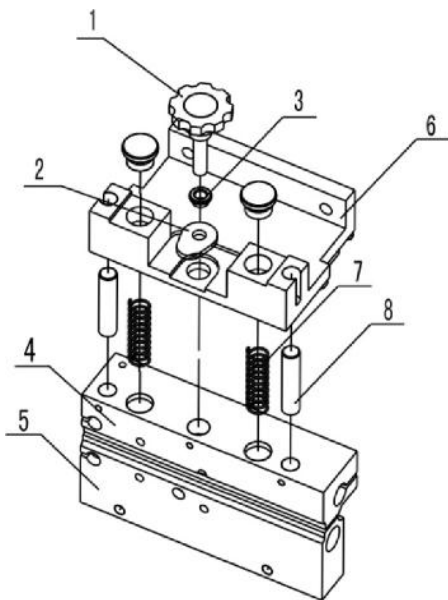

Figure 6. (1) Control Block Knob, (2) Adjusting Nut, (3) Nut, (4) Upper Heating Block, (5) Lower Heating Block, (6) Block Holding Plate, (7) Spring, (8) Guide Post

5. Adjust the conveyor position forwards or backwards. Refer to **Figure 7** for knob adjustments. For vertical configuration only, adjust the height of the band sealer appropriate for your bag to be sealed.

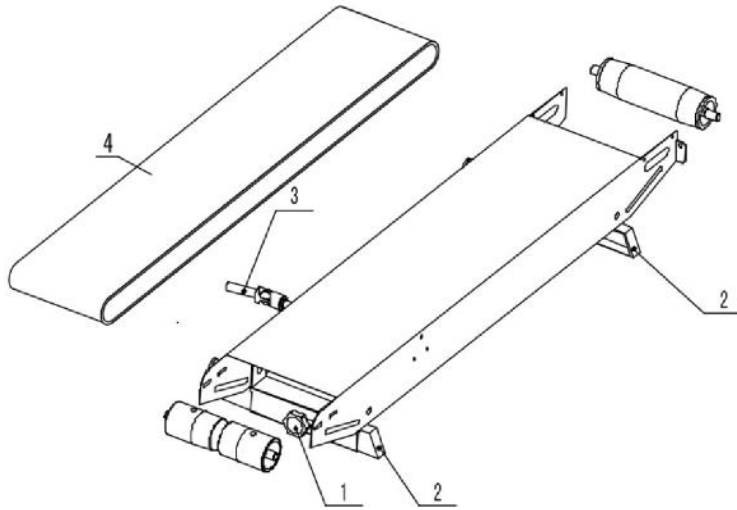

Figure 7. (1) Adjusting Knob, (2) Foot Rest, (3) Gimbal Assembly, (4) Conveyor Belt.

6. Adjust the guide to adjust seal width and position of seal line on your material.



To adjust the position of the seal line, move the guide forwards or backwards. Moving the guide forward (left) will move the seal line towards the top of the bag and moving the guide back (right) will move the seal line towards the bottom of the bag.

Figure 8. Band Sealer Guide

Operation



Figure 9. Control Panel of FRM-1010

1. Switch the circuit breaker to the "On" position.
2. Turn Power, Heater, and Fan switches to the "On" position. Belts and conveyor will begin to move simultaneously.
3. Emergency Stop – Press the emergency stop to turn off the machine. In order to restart the machine, you must release the emergency stop by turning the knob 120° clockwise.
4. Adjust the conveyor speed.
5. Adjust the temperature controller to the temperature desired to seal your material. Temperature settings will vary based on bag material and thickness. If you are unsure what temperature setting to use, we recommend starting at a low temperature (150°C) and gradually increase to a temperature that will seal your material. We highly discourage sealing material at a temperature above 200°C. **Please note: Temperature will be in Celsius, not Fahrenheit.** The temperature controller cannot be displayed in Fahrenheit.

The PV value (red light) is the actual temperature and the SV value (green light) is the desired temperature setting.

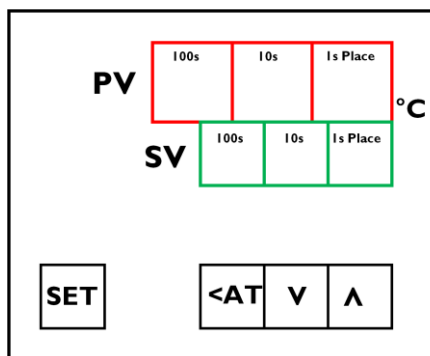

Figure 10. FRM-1010 Temperature Controller

- a. To set the temperature, press the SET button.
 - b. Press the <AT (auto tuning) button to move from the ones, tens, and hundreds place. Adjust the value using the up and down arrows.
 - c. Press the SET button to save the temperature settings. Your desired temperature settings should appear in green in the SV Value.
 - d. Wait until the PV temperature matches the SV temperature which should take approximately 5-10 minutes.
 - e. **Please note:** Temperature will be in **Celsius**, not Fahrenheit. Do not attempt to make additional adjustments to the temperature controller besides the temperature. The temperature controller CANNOT be displayed in Fahrenheit and is ALWAYS in Celsius. **Please do not set the temperature controller above 200°C.** Please contact your local distributor if you need assistance.
6. Adjust the pressure knob on your band sealer depending on the thickness of your bag material.
 7. Place material on the guide (**Figure 36, Item #1**) and allow the band sealer to pull your material through. Make sure your material is flat on the guide. While the material is moving through the band sealer, do not push or pull the material as this will cause irregular sealing.
 8. If the sealing belt is running off the guide wheels, make adjustments to the screws that are found on the driven wheel seat (**Figure 11, Item #1 & 2**)

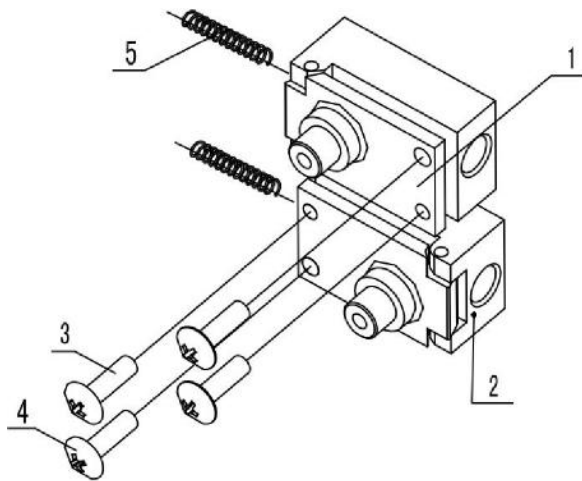

Figure 11. (1) Driven Wheel Seat (Adjusting Block), (2) Driven Wheel Seat (Adjusting Block), (3)/(4) Adjusting Screws, (5) Springs

9. Emergency Stop – Press the emergency stop to turn off the machine. In order to restart the machine, you must release the emergency stop by turning the knob 120° clockwise.
10. To shut down, turn off the heater switch and allow the temperature of the machine to drop before turning off the power and fan switches. *Following this shut down procedure will significantly prolong the life of machine and sealing belts.*

Sealing Optimization

1. Sealing performance can be adjusted with the sealing temperature and sealing speed. The higher the speed the less exposure the material to heating blocks and therefore a higher temperature will be required to seal the material.
2. Try a variety of different sealing temperatures and conveyor speeds to get the optimal seal for your material.

Printing Operation

FRM-1010 is equipped with a dry ink coding feature capable of printing characters at the seal line. Ink dries instantly upon contact with packaging materials and produces clear and legible letters/numbers. Standard font size is 18PT which allows for two-line printing up to 20 characters per line. Optional print wheel which allows for 40 characters per line is available to be purchased separately. In addition, we also carry 10.5PT font size which allows for three-line printing can also be purchased separately. Ask your distributor for more details. Check our YouTube channel (<https://www.youtube.com/user/sealersales>) for a video demo.



Figure 12. Standard font size - 18PT

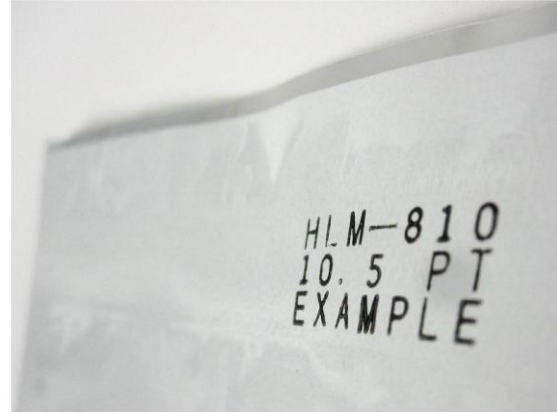

Figure 13. Optional 10.5PT font size available for purchase

1. **Removing Print Wheel.** To remove the printing wheel from the base, push the red handle in and turn clockwise until you feel the handle unlock. (See [Figure 14](#) and [Figure 15](#) for locked and unlocked positions). You may need to turn the wheel a few times until the red handle unlocks and pops out of its locked position.

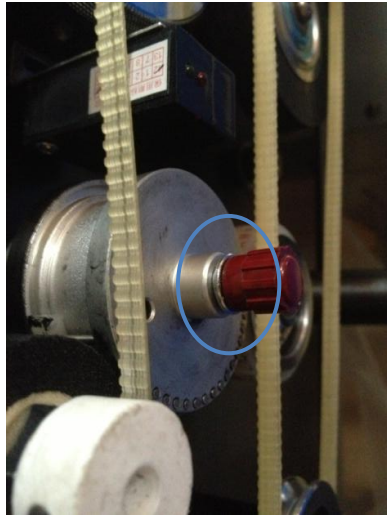

Figure 14. Locked Handle Position

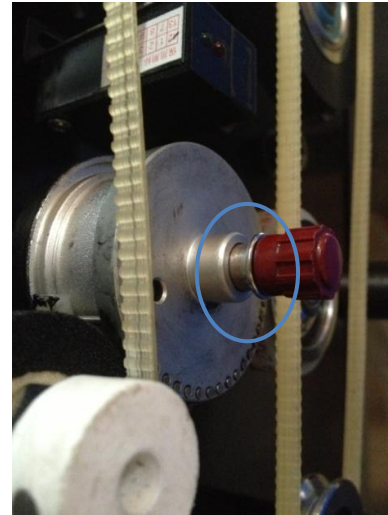

Figure 15. Unlocked Handle Position

- 2. Installing Types/Characters on Print Wheel.** Place selected characters in the grooves of the printing wheel. Be sure to insert the characters from right to left to ensure actual imprint prints correctly on your packaging material. Once completed, insert the silicone pin at the top of the printing wheel to hold the characters in place.



Figure 16. Place characters from right to left.



Figure 17. Place silicone pin to lock characters in place.

- 3. Installing the Print Wheel.** To insert the spring-loaded print wheel into the print wheel base, ensure that the pins on the printing wheel are aligned with the notches of the print wheel base. Gently insert the print wheel into the base. Lock the print wheel by pushing the red handle in until you feel the handle lock into place.



Figure 18. Ensure two holes and pins line up with the base

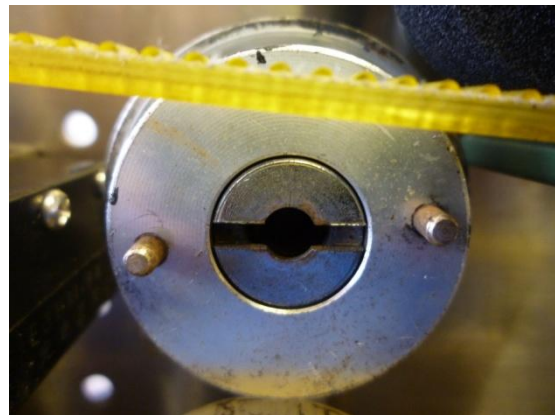

Figure 19. Ensure two holes and pins line up with the base

4. **Install Ink Roller into the Ink Roller Holder.** Remove the metal ring found on the ink roller holder using an allen wrench. Place the ink roller onto the ink roller holder and place the metal ring back on the ink roller holder to hold the ink roller in place. Please note that for 30mm wide ink roller, the metal ring will not be used.



Figure 20. Remove metal ring found on the ink roller holder



Figure 21. Ink roller installed on ink roller holder

5. **Insert Ink Roller in the Ink Wheel Heating Block.** When inserting the ink roller, ensure the ink roller lines up with the type on the printing wheel. If the ink roller is pushed in too far, the printing wheel will not print correctly. *Note: Do not allow the ink roller to heat continuously when machine is not in use as heating block may melt the ink roller.*

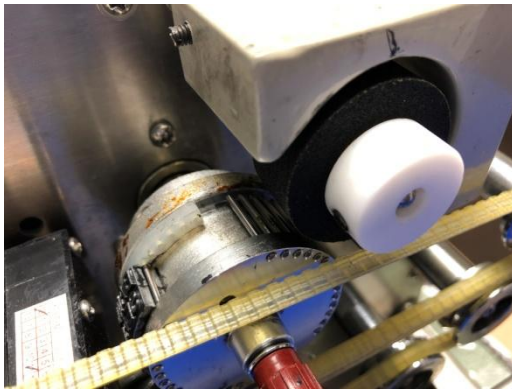

Figure 22. Correct Ink Roller Position

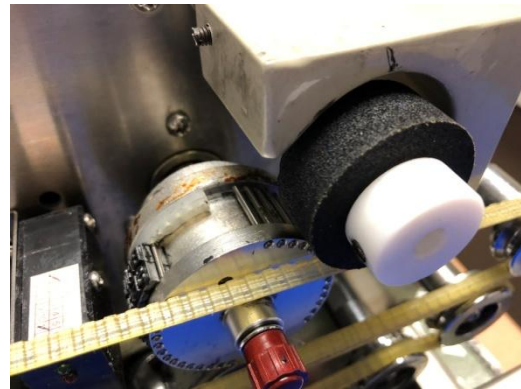

Figure 23. Incorrect Ink Roller Position

Test the ink roller position relative to the printing wheel. Place your finger under the photoelectric sensor (Figure 40, Item #29). The sensor light will turn green and allow the printing wheel to rotate.

6. **Make Adjustments to Ink Wheel Adjusting Device.** As the print wheel rotates, check that the printing wheel makes contact with the ink roller. Make adjustments using the ink wheel adjusting device (Figure 24, Item #5) if necessary. Turning the adjusting screw clockwise will move the ink roller away from the print wheel and turning the adjusting screw counterclockwise will move the ink roller closer to the print wheel.

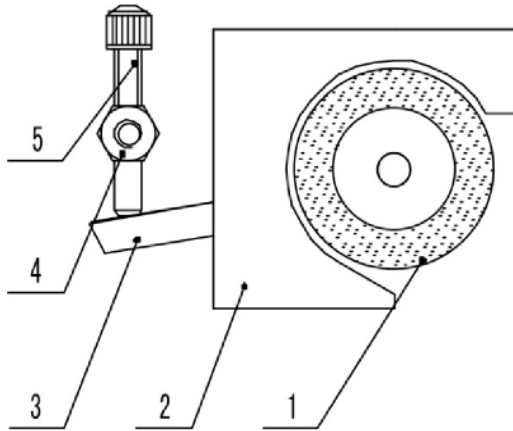

Figure 24. (1) Ink Roller, (2) Ink Roller Heating Block, (3) Swing Pole, (4) Adjusting Strut, (5) Ink Wheel Adjusting Device

7. **Make Adjustments Between Printing Wheel and Silicone Wheel.** The typesets/characters on the printwheel should only touch the silicone wheel during the printing process. The characters should not touch the silicone wheel at any other time. If the band sealer is used to seal relatively thicker materials, the screw (Figure 25, Item #4) should be loosened. Rotate the eccentric sleeve (Figure 25, Item #3) to ensure the characters/typesets slightly touch the silicone wheel's surface. Refasten the screw after making adjustments.

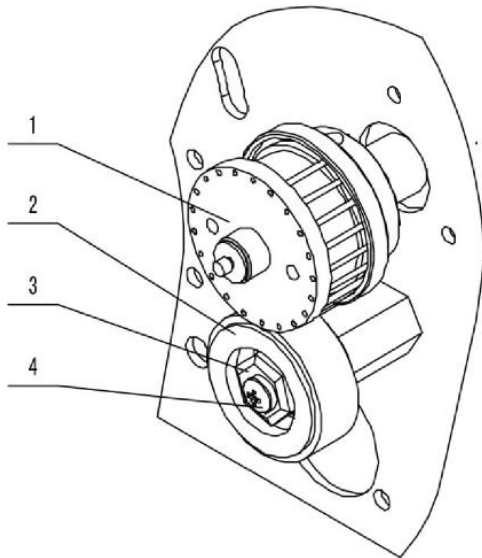

Figure 25. (1) Printing Wheel, (2) Silicone Wheel, (3) Eccentric Sleeve, (4) Screw

8. **Setting Printing Temperature.** We recommend setting the ink temperature on the higher end. Allow 5-10 minutes for the ink heating block and ink roller to reach the correct temperature. *Note: If band sealer is not in use right away, do not leave ink roller in the unit while temperature is on. This may result in the ink roller melting and producing messy print.*
9. **Adjusting Printing Position.** The coding seat knob determines printing position on your material. For example, if you want to print on the right side of your bag, turn the coding seat to

its lowest setting (or counterclockwise). If you want to print on the left side of the bag, turn the coding seat to a higher setting (or clockwise).

Printing Optimization

1. Print quality will be determined by the degree of ink melting, distance between the ink roller and printing wheel and distance between the silicone wheel and printing wheel.
2. Over time, decrease the gap between the ink roller and printing wheel.
3. A newer ink roller will require a lower temperature vs. an older ink roller. Make adjustments to ink temperature as necessary.
4. Ensure there is adequate pressure on the silicone wheel (**Figure 36, Item #31**) by the printing wheel. We suggest using factory default settings before making any adjustments. Adjustments may be needed based on material thickness.
5. If the printing wheel rotates and there is no thermoplastic material running through the band sealer, excess ink will rub off on the silicone wheel. Clean the silicone wheel with a shop cloth and silicone spray to remove any excess ink.
6. ***Remove the ink roller from unit until sealer is ready for use. If ink roller is left in the machine while not in use, this may result in melting of the ink roller and messy print. To clean, wipe down belts, silicone wheel, and other parts with silicone spray and cloth.***

Maintenance

The following maintenance procedures should be followed to ensure the longevity of your FRM-1010 band sealer.

Inspection and Cleaning

1. Inspect your machine daily.
2. Check if there is any foreign matter or dirt adhering to the band sealer.
3. To clean your band sealer, wipe down your sealer with silicone spray and a shop cloth. Do not apply silicone directly to your sealer. Definitely DO NOT wash down your machine with water.

Sealing and Drive Belts

1. Check and replace the belts as necessary. Both the sealing and drive belts are consumable items. Replace sealing belts when there are burn marks or if the belts become hard and brittle. Replace drive belts when the belts break or become badly cracked.
2. To change out the belts, make sure the machine is turned off.
3. Lift the safety cover. You may need to remove the safety cover.
4. Remove the two drive belts. Gently tug both belts out of the small pulleys and release belts from driving wheel.
5. To remove the sealing belts, push on the adjustment blocks ([Figure 36, Item #51](#)) and the sealing belts should easily slip off.
6. Put new sealing back on the machine. Test the machine, making adjustments as necessary.
 - a. To install the upper sealing belts, place the belt in between the drive and driving wheels. Push the adjustment blocks and slide the sealing belts in place. Lift the adjusting screws on top of the heating and cooling blocks and adjustment placement of the sealing blocks.

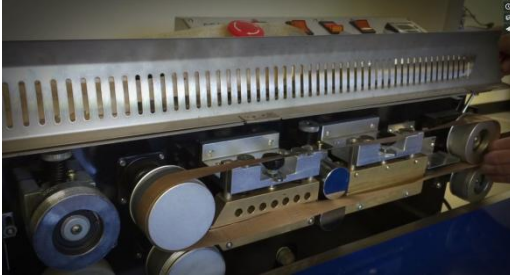

Figure 26.



Figure 27.

- b. To install the lower sealing belts, first remove the guide (Part#FRM-1010-34). Push the adjustment blocks and slide the sealing belts in place. Guide the sealing belts in place.



Figure 28.



Figure 29.

7. Install the new drive belts. Start by placing them on the grooves found on the driving wheel and small pulley

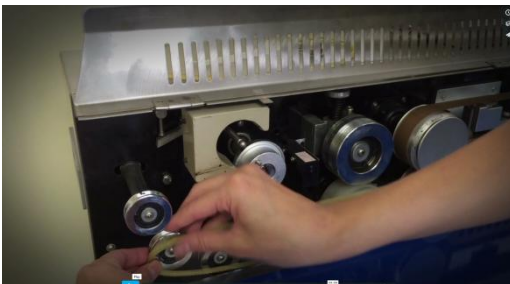

Figure 30.



Figure 31.

8. Replace the safety cover.
9. Check out our video demonstration (<https://vimeo.com/270233770>) for more information.

Turbocase Maintenance

1. Remove dust and clean motor at regular intervals. Avoid contact with alcohol, gasoline and benzene chemicals.
2. The turbocase should be oiled monthly with 50g 20# oil by:
 - a. Remove the back cover.
 - b. Locate the turbocase and unscrew the cap. Replenish any depleted gear oil with 50g 20# oil.
3. The motor brush (**Part# BS-29A**) is designed to be used 2,500 hours continuously. Replace carbon brush at regular intervals.

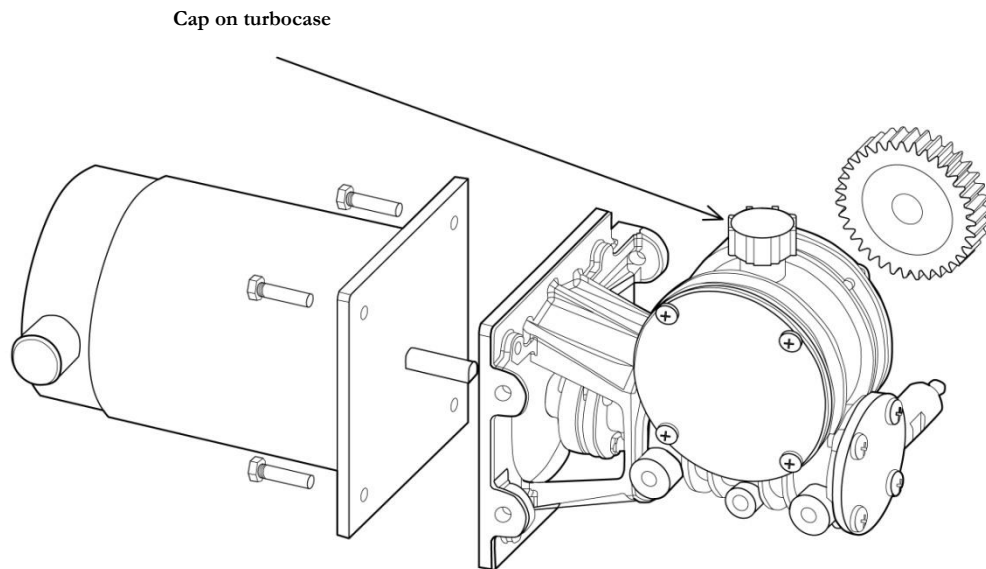

Figure 32. Turbocase cap

Printing Maintenance

FRM-1010 band sealers are equipped with an ink temperature potentiometer which is attached to a PC Board. This part controls the temperature that is transmitted to both the ink heating block as well as the printing wheel. The part is located behind the ink temperature knob. **(Figure 45, Item #3-3)** You should change the ink temperature potentiometer w/ PC Board when both ink heating block and printing wheel on your band sealer are not achieving optimal heat temperatures.

1. Turn off and unplug your band sealer.
2. Remove ink temperature knob from potentiometer and remove the washer that holds the ink temperature potentiometer on the panel.



Figure 33. Remove Ink Temperature Knob



Figure 34. Remove Washer Holding Ink Temperature Potentiometer

3. Remove the band sealer display panel. There should be six screws to remove.
4. Unplug the ink temperature potentiometer and plug in a new ink temperature potentiometer. Make sure the part is plugged in properly and tight.

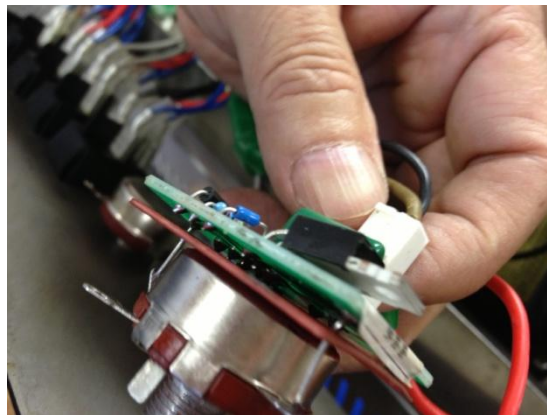

Figure 35. Unplug Ink Temperature Potentiometer w/ PC Board and Replace with a New Ink Temperature Potentiometer w/ PC Board

Parts Diagram

To order spare parts, please use diagram and part #s below:

Figure 36 – Spare Parts Diagram Overview

Figure 38 – Heating / Cooling Blocks

Figure 40 – Dry Ink Coding

Figure 42 – Conveyor Table

Figure 44 – Motor / Turbocase

Figure 45 – Sealer Body

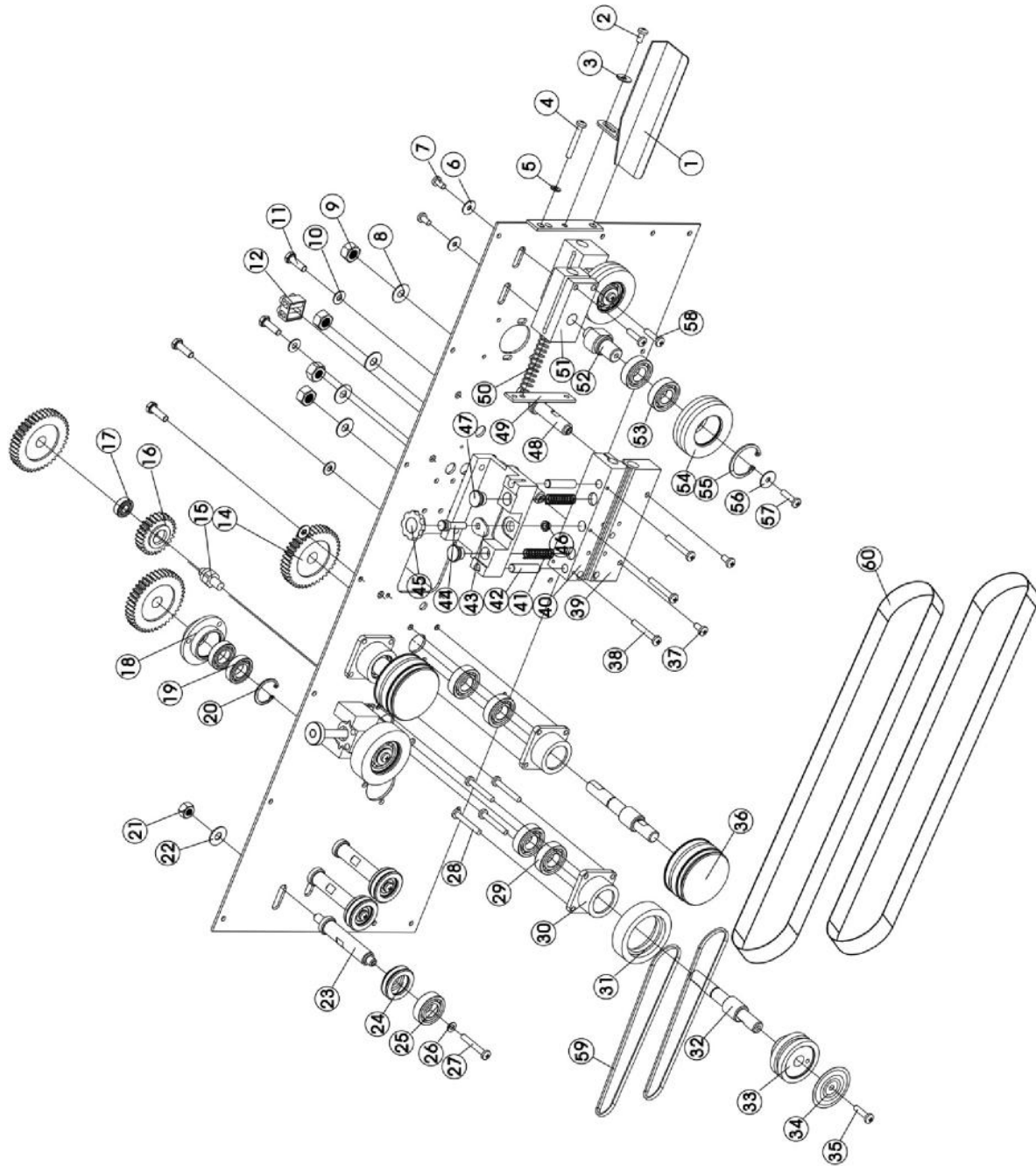

Figure 36. Spare Parts Diagram Overview

Figure 37. Spare Parts Diagram Overview

Item	Part #	Quantity	Description	Comments
1	FRM-1010-44	1	feed opening	
2			plus screw	
3			washer	
4			plus screw	
5			washer	
6			washer	
7			screw	
8			washer	
9			hexagon nut	
10			washer	
11			hexagon nut	
12	BS-33A	1	wiring terminal(H5219-2T)	
14	FRM-1010-35B		drive gear	
15		1	driven wheel shaft	
16	FRM-1010-35E		driven gear	
17			bearing of driven wheel	
18		1	bearing seat	
19			bearing	
20			circlip	
21			hexagon nut	
22			washer	
23		2	shaft of small pulley	
24		2	small pulley	
25			bearing of small pulley	
26			washer	
27			plus screw	
28			plus screw	
29			bearing of silicone wheel	
30	CBS-880-6-27A	2	bearing seat	

FRM-1010 INSTRUCTION MANUAL

Item	Part #	Quantity	Description	Comments
31	BS-57A	1	silicone wheel	
32		1	silicone wheel shaft	
33			silicone wheel	
34	BS-57	1	cover of silicone wheel	
35			plus screw	
36	FRM-1010-6	2	driving wheel	
37	Screw-BS-M3x6		screw M3x6	
38	Screw-BS-M4x35		screw M4x35	
39	FRM-1010-9A	1	bottom heating block	Includes #39, 40
40	FRM-1010-9A	1	upper heating block	Includes #39, 40
41	FRM-1010-8/9-41		regulating spring	
42	FRM-1010-8/9-42	2	guide post	
43	FRM-1010-8/9-43		adjusting nut	
44	FRM-1010-8/9-44.46	2	adjusting screw	Includes #44, 46
45	FRM-1010-8/9-45		knob of control rod	
46	FRM-1010-8/9-44.46		spring seat	Includes #44, 46
47	FRM-1010-8/9-47	4	adjusting screw	
48		2	shaft of heating block	
49		1	spring seat of driven wheel	
50			adjusting spring of driven wheel	
51	FRM-1010-13	2	adjusting seat of driven wheel	
52		2	driven wheel shaft	
53	FRM-1010-12		bearing	Includes #53,54
54	FRM-1010-12	1	driven wheel	Includes #53,54
55			circlip	
56			washer	
57			plus screw	
58			plus screw	
59	FRM-1010-26	2	guiding belt	
60	FRM-1010-10	2	sealing belt	

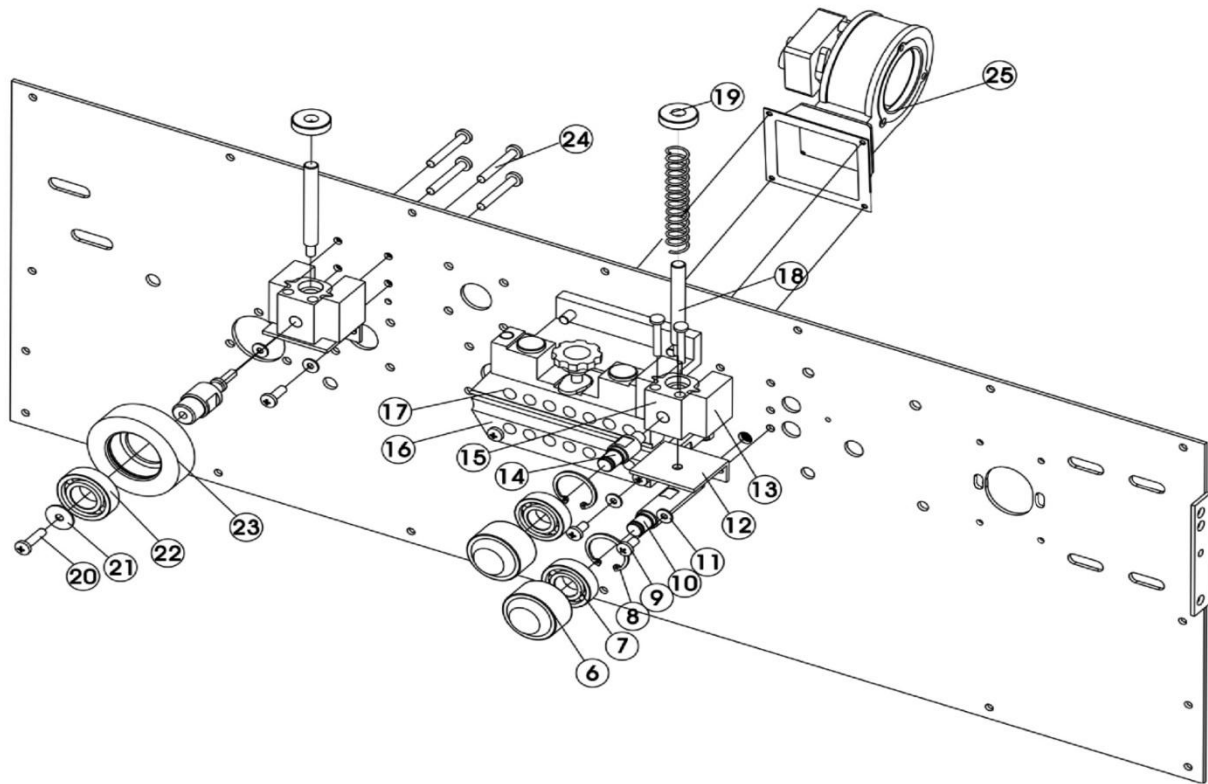

Figure 38. Heating / Cooling Blocks

Figure 39. Heating / Cooling Blocks

Item	Part #	Quantity	Description	Comments
6	FRM-1010-21	2	pinch roller	Includes #6, #7
7	FRM-1010-21		bearing of pinch roller	Includes #6, #7
8			circlip	
9			plus screw	
10		1	shaft of pinch roller	
11			washer	
12			seat for adjusting screw	
13			guide rail of embossing roller seat	
14			upper pinch roller seat	
15		1	embossing roller seat	
16	FRM-1010-8	1	bottom cooling block	Includes #16, 17
17	FRM-1010-8	1	upper cooling block	Includes #16, 17
18			control rod	
19			knob of control rod	
20			plus screw	
21			washer	
22			bearing	
23		1	embossing roller	
24			plus screw	
25	HL-M810-32	1	fan assembly (CY063)	
26				
27				
28				
29				
30				
31				

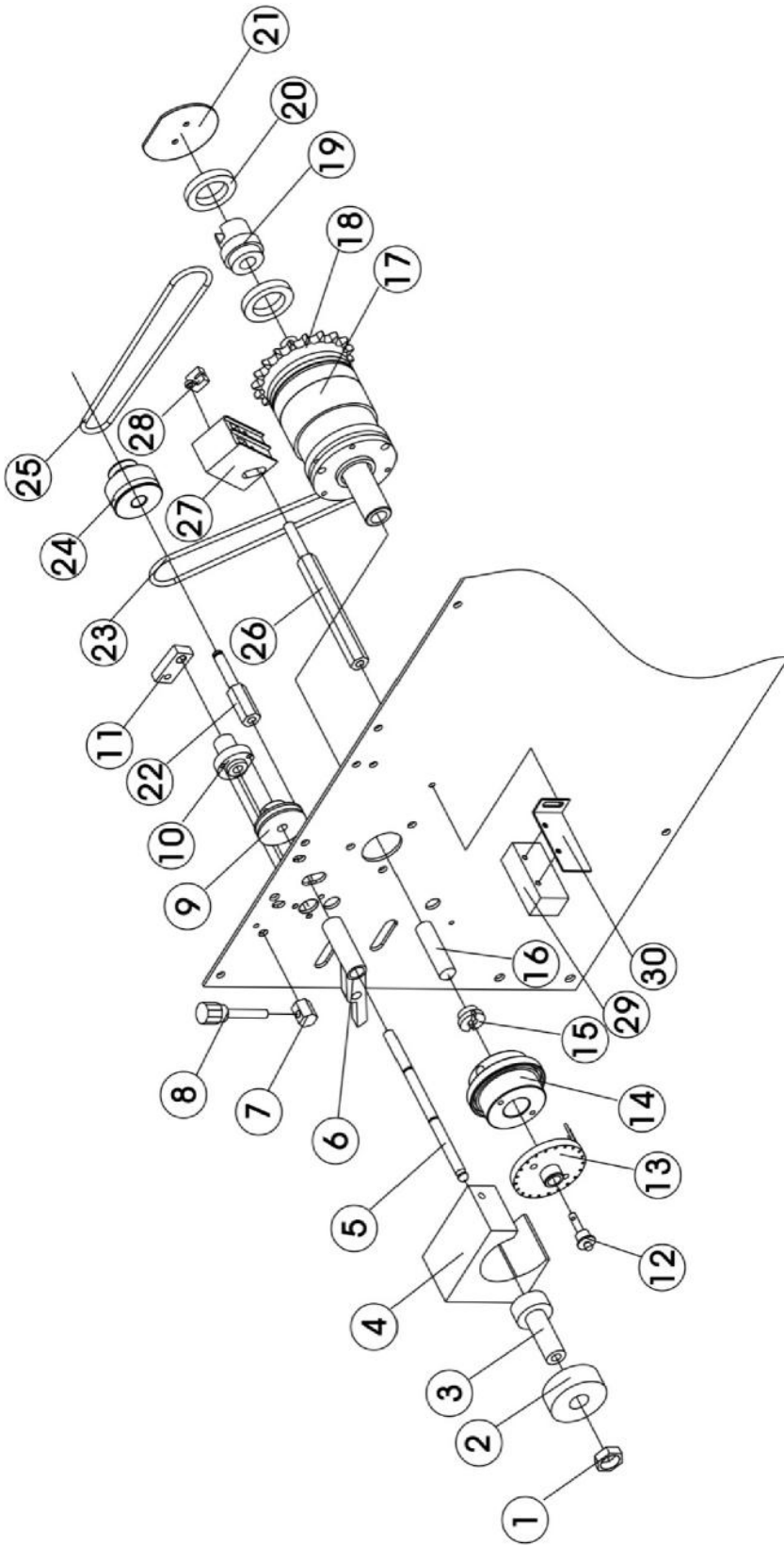

Figure 40. Dry Ink Coding

Figure 41. Dry Ink Coding

Item	Part #	Quantity	Description	Comments
1	BS-58	1	jam nut	Includes #1, 3
2	IT-IR-15-Color	1	ink roller (15mm)	
	IT-IR-30-Color		ink roller (30mm)	
3	BS-58	1	ink roller sleeve	Includes #1, 3
4	FRM-1120C-47	1	heating block of ink roller	
5	BS-46	1	ink roller shaft	
6	BS-62E-FRM	1	swing pole of ink roller	
7	BS-62		adjusting post for ink roller's swing pole	Includes #7, 8
8	BS-62		adjusting knob for ink roller's swing pole	Includes #7, 8
9	BS-54C	1	pulley of ink roller shaft	
10	BS-54C-34	1	seat for ink roller swing pole shaft	
11	BS-62H	1	pull rod	
12	BS-48A	1	holding latch for printing wheel	Includes #12,13
13	BS-48A	1	printing wheel cover	Includes #12,13
14	BS-48B	1	printing wheel seat assembly	
15	BS-48D	1	end cover of printing wheel shaft	
16	BS-48C	1	heating tube $\Phi 10$ 110V 40W	
17	BS-139-FRM-1010	1	electromagnetic clutch assembly	Includes #17-20
18	BS-139-FRM-1010	1	driven sprocket	Includes #17-20
19	BS-139-FRM-1010	1	slip ring core	Includes #17-20
20	BS-139-FRM-1010	2	copper slip ring	Includes #17-20
21	BS-140		anti-dazzling screen	
22	BS-54B-35	1	middle pulley shaft	
23	BS-54	1	O-Ring ($\Phi 30 \times 60$)	
24	BS-54B	1	middle pulley	
25	BS-53	1	O-Ring ($\Phi 30 \times 50$)	
26	BS-64B	1	support for brush	
27	BS-64A	1	carbon brush holder	
	BS-64	2	carbon brush	
28	BS-65	1	groove sensor	
29	BS-60	1	photoelectric sensor	
30	BS-60-18	1	support for photoelectric sensor	

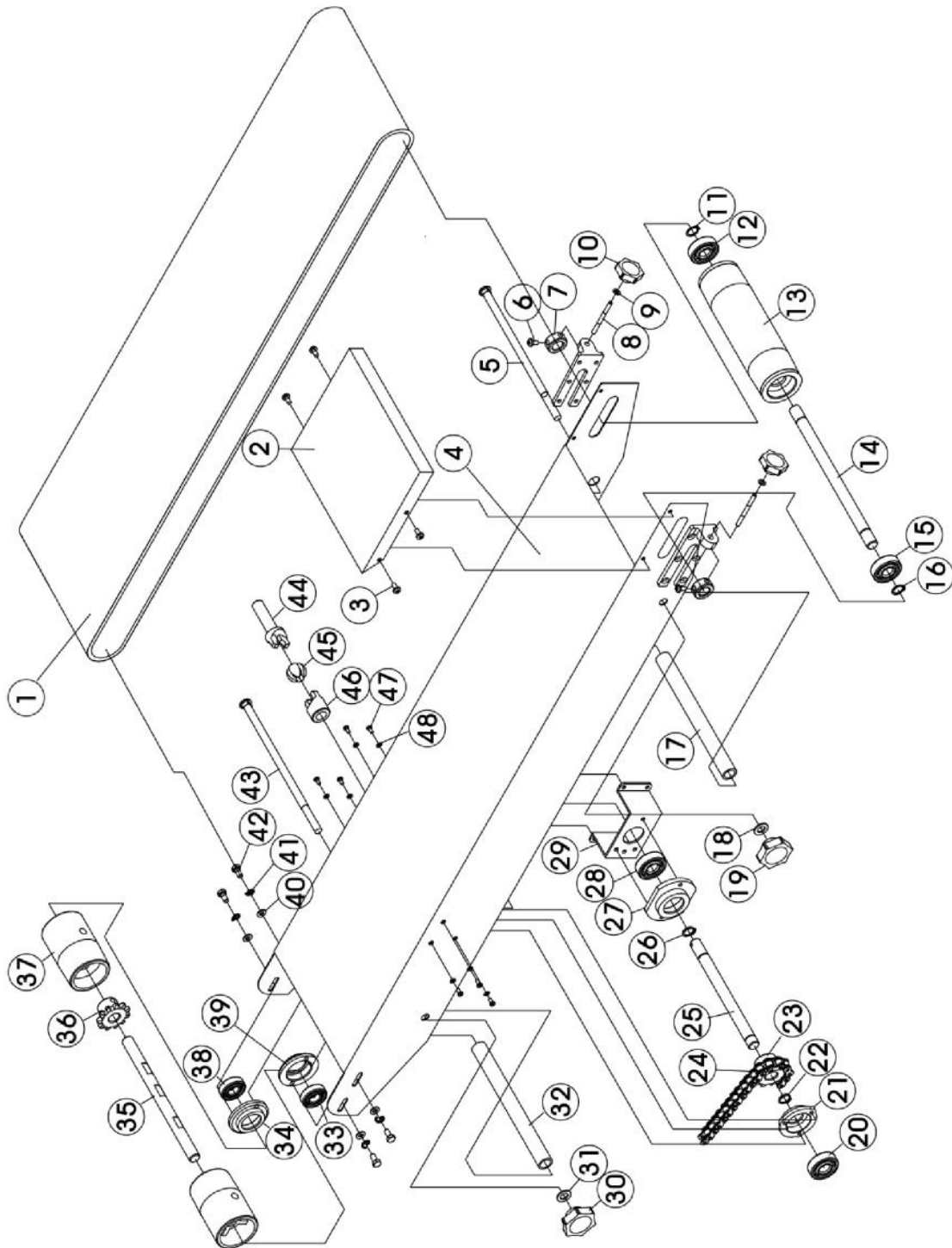

Figure 42. Conveyor Table

Figure 43. Conveyor Table

Item	Part #	Quantity	Description	Comments
1	FRM-1010-1	1	conveyor belt	
2	FRM-1010-15	1	stock supporting plate	
3			plus screw	
4	FRM-1010-20		conveyor table	
5	FRM-1010-18		half-round square neck bolt	Includes #5, 17-19
6	FRM-1010-16		plus screw	Includes #6-10
7	FRM-1010-16		adjusting block of conveyor belt	Includes #6-10
8	FRM-1010-16		double end bolt	Includes #6-10
9	FRM-1010-16		washer	Includes #6-10
10	FRM-1010-16	4	knob	Includes #6-10
11	FRM-1010-36		circlip	Includes #11-16
12	FRM-1010-36		bearing	Includes #11-16
13	FRM-1010-36	1	rear roller (right conveyor roller)	Includes #11-16
14	FRM-1010-36	1	rear roller shaft	Includes #11-16
15	FRM-1010-36		bearing	Includes #11-16
16	FRM-1010-36		circlip	Includes #11-16
17	FRM-1010-18	2	separating tube	Includes #5, 17-19
18	FRM-1010-18		washer	Includes #5, 17-19
19	FRM-1010-18	8	knob	Includes #5, 17-19
20	FRM-1010-41		bearing	Includes #20-23, 25-29
21	FRM-1010-41		bearing seat	Includes #20-23, 25-29
22	FRM-1010-41		circlip	Includes #20-23, 25-29
23	FRM-1010-41	1	sprocket of conveyor table	Includes #20-23, 25-29
24	FRM-1010-38	1	chain	
25	FRM-1010-41	1	middle shaft of conveyor table	Includes #20-23, 25-29
26	FRM-1010-41		circlip	Includes #20-23, 25-29
27	FRM-1010-41		bearing seat	Includes #20-23, 25-29
28	FRM-1010-41		bearing	Includes #20-23, 25-29
29	FRM-1010-41		underlay plate of middle shaft	Includes #20-23, 25-29
30	BS-17		knob	
31	FRM-1010-18		washer	
32	FRM-1010-18		separating tube	
33	FRM-1010-37		bearing	Includes #33-39
34	FRM-1010-37		bearing seat	Includes #33-39
35	FRM-1010-37		front roller shaft (left)	Includes #33-39
36	FRM-1010-37	1	sprocket of conveyor table	Includes #33-39
37	FRM-1010-37	1	front roller	Includes #33-39
38	FRM-1010-37		bearing	Includes #33-39
39	FRM-1010-37		bearing seat	Includes #33-39
40			flat washer	
41			spring washer	
42			plus screw	
43			half-round square neck bolt	
44	FRM-1010-40A		adjusting shaft	Includes #44-46
45	FRM-1010-40A		connecting ball	Includes #44-46
46	FRM-1010-40A		connector	Includes #44-46
47			plus screw	
48			flat washer	

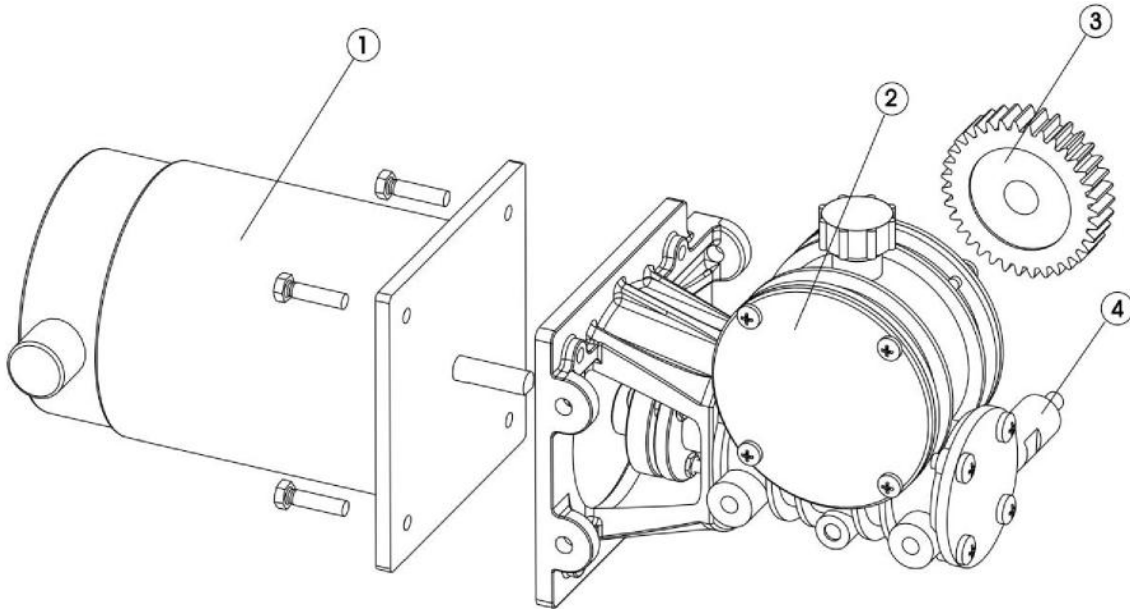

Figure 44. Motor / Turbocase

Item	Part #	Description	Quantity	Comments
1	CBS-880-29	110V DC motor	1	
	FRM-1010-20_Gen2.0	110V DC motor	1	
	BS-29A	motor brush	2	Not shown.
2	FRM-1010-30	worm-gear case assembly	1	
3		driving gearwheel	1	
4		pig iron gearwheel / turbocase support	1	

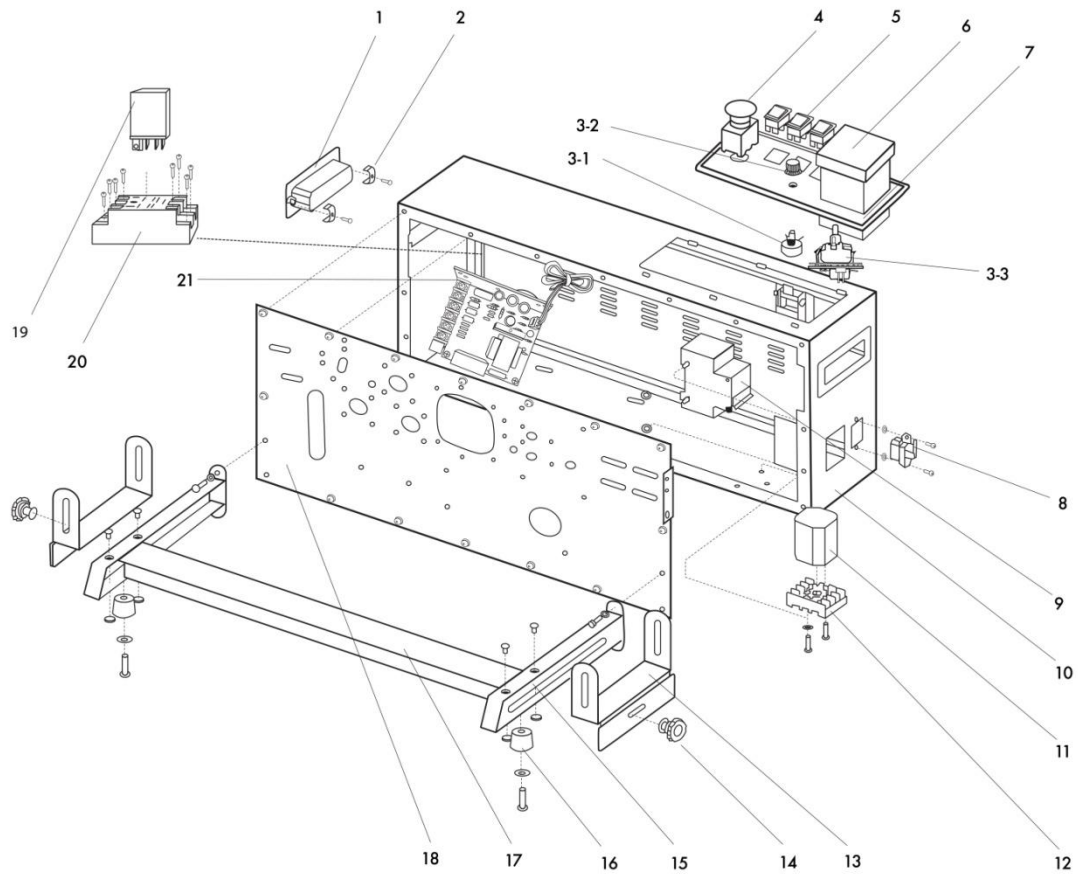

Figure 45. Sealer Body

Figure 46. Sealer Body

Item	Part #	Description	Quantity	Comments
1	FRM-1010-88-1	handle support	2	Includes #1, #2
2	FRM-1010-88-1	handle clamp	4	Includes #1, #2
3-1	BS-25	carbon-film potentiometer 220K	1	
3-2	BS-25A	K18-2 knob	1	
3-3	BS-50A	ink temperature potentiometer w/ PC Board	1	
4	BS-22A	emergency stop switch	1	
5	BS-22	springboard switch	3	specify large or small
6	TMC-XMTG-1000-2	2301 temperature controller	1	
	TMC-NG-5000	temperature controller	1	determine version
7	FRM-1010-83	plastic panel	1	A: old gen / B: new gen
8	BS-14	10 ³ socket		
9	BS-27	DZ47-2P/5A breaker	1	
10	FRM-1010-88	housing	1	
11	BS-52A	speed-regulating plate (8 PINS)	1	
12	BS-45A	PF083A socket	1	
13	FRM-1010-18	transition table support	2	Includes #13, #14
14	BS-17	(674 Knob) handle	2	Includes #13, #14
15	FRM-1010-68	foot	2	specify left or right
16	BS-67B	rubber foot pad	2	specify A or B
17	FRM-1010-68B	rail	1	
18	FRM-1010-88-18	soleplate (electrophoresis)	1	Steel: 102102-3
19	R-JQX-13F	relay	1	
20	BS-74A	seat for relay	1	
21	FRM-1010-31	PC Board	1	

Troubleshooting

Problem	Possible Causes	Solution
Sealing belt is off tracking.	Driving wheel shaft is not parallel to driven wheel shaft	Adjust two adjusting screws on the adjusting block seat (Part# FRM-1010-13)
Sealing belts are tearing	<ol style="list-style-type: none"> 1. Too much tension on sealing belt 2. Sealing belt is off tracking 3. Creases on the sealing belt 4. Residual film or other debris attached to the sealing belt 	<ol style="list-style-type: none"> 1. Adjust the vertical adjusting screw on driven wheel seal to decrease tension on sealing belt 2. see above 3. When installing belt, make sure no creases are found on belt 4. Clean surface of belt with cloth
Seal is crumpled and film sticks to sealing belts	<ol style="list-style-type: none"> 1. Temperature is too high 2. Guide belt is not correctly in place 3. Plastic melted on the sealing belt 	<ol style="list-style-type: none"> 1. Reduce temperature 2. Adjust guide belt 3. Clean or replace sealing belt <p>If any plastic melts on the sealing belt, your bags will stick to the melted plastic</p>
Embossing is not clear	<ol style="list-style-type: none"> 1. Embossing roller is worn out 2. Pressure spring on embossing roller needs to be tightened 	<ol style="list-style-type: none"> 1. Replace embossing roller 2. Adjust the embossing roller spring (Part# BS-5)
Material will not pass through sealing blocks	Clearance between heating blocks or cooling blocks may be too small	Adjust the clearance between blocks by adjusting the springs and stopping flakes found above the blocks
Conveyor belt is off tracking	Driving roller shaft is not parallel to the driven roller shaft	Adjust using the conveyor belt adjustment (Part# BS-16)
Conveyor and sealing belt are not moving at same speed	Not enough tension on conveyor belt	<ol style="list-style-type: none"> 1. Tighten the chain of driving roller shaft (front shaft) and middle shaft. (Parts # HL-M810-36 and HL-M810-41) 2. Tighten the conveyor belt
Temperature doesn't rise or cannot be controlled	<ol style="list-style-type: none"> 1. Heat switch is damaged 2. Heater (BS-9B) is damaged 3. Temperature Controller 4. Coupling 	Replace: <ol style="list-style-type: none"> 1. Heat switch (BS-22-Large) 2. Heater (BS-9B) 3. Temperature Controller 4. Thermocouple (FRM-1010-34)

Problem	Possible Causes	Solution
Printing wheel does not rotate	<ol style="list-style-type: none"> 1. Sensor is blocked 2. Sensor is not clean and eye is blocked by dust 	<ol style="list-style-type: none"> 1. Make sure sensor is not blocked 2. Clean sensor 3. Replace PCB (BS-53C)
Printing wheel does not stop rotating	<ol style="list-style-type: none"> 1. Sensor (groove) is damaged or dirty 2. Photoelectric sensor is damaged or dirty 	<ol style="list-style-type: none"> 1. Replace or correct position of the groove sensor or clean its surface (BS-65) 2. Replace or clean photoelectric sensor (BS-60)
No heat on the ink heating block	<ol style="list-style-type: none"> 1. Heating element in heating block is damaged 2. Heating PCB is damaged 3. Potentiometer w/ PC Board (BS-50A) is damaged 4. Carbon brush is not in place 5. Carbon brush is damaged 	<ol style="list-style-type: none"> 1. Replace element (BS-48C) in heating block 2. Replace PCB (BS-50A) 3. Replace potentiometer with PC Board (BS-50A) 4. Adjust and tighten nut on carbon brush seat 5. Replace carbon brush
Temperature of heating block for ink roller cannot be regulated	Relay for temperature control PCB is damaged	Check and replace temperature control PCB (BS-50A)
Printing position cannot be regulated	<ol style="list-style-type: none"> 1. Tighten screw on printing wheel 2. Coding seat potentiometer may be damaged 	<ol style="list-style-type: none"> 1. Tighten screw on printing wheel. 2. Replace coding seat potentiometer (BS-51)
Motor runs at a high speed and cannot be regulated	Speed controller has malfunctioned	Replace the speed controller (BS-52A)
Power, heater, and or fan switches do not light up	<ol style="list-style-type: none"> 1. No AC Voltage 2. Open Fuse 3. Lamp is damaged 	<p>Check power source / power cord</p> <p>Connect the power</p> <p>Replace the fuse</p> <p>Replace the lamp</p>

Problem	Possible Causes	Solution
Machine does not run	<ol style="list-style-type: none"> 1. Board for speed regulation is abnormal 2. Doesn't connect well 3. Brushes in the motor are too short because of friction 	<ol style="list-style-type: none"> 1. Replace the speed board (BS-52A) 2. Tighten the connecting screws 3. Replace motor brushes (BS-29A) <p>If the temperature controller works and the power lamp illuminates but the motor does not move, start off by checking the motor and turbocase connection. Remove the back of the machine and you will see bushing where the motor connects to the gear box. Ensure the bushing is not broken. There is also a set screw that connects the bushing to the gear box / motor shafts. Ensure that these are tight so that when the motor turns, the turbocase turns as well.</p> <p>If the turbocase is noisy before it stopped working, the gear box could be broken inside. Lack of oil could cause this.</p> <p>If the lamp illuminates and the motor does not turn, the motor speed controller may need to be replaced.</p>

Spare Parts List

Included with your band sealer are the following parts. Please note that spare parts included with your band sealer are subject to change without notice.

- ❖ Typeset Box which includes numbers (0-9), Letters – EXP, MFD, silicone pins (Part# BS-59), tweezers, and allen wrench
- ❖ Power Cord (Part# PWC-CBS)
- ❖ PTFE Sealing Belts (Part# FRM-1010-10)
- ❖ Drive Belts (Part# FRM-1010-26)
- ❖ Speed Adjusting PC Board (Part# BS-52A)
- ❖ Central Circuit PC Board (Part# BS-52C)
- ❖ Ink Temperature Potentiometer with Heat PC Board (Part# BS-50A)
- ❖ O-Rings (Part#s BS-53 and BS-54)
- ❖ Silicone Ring (Part#BS-57A)
- ❖ Ink Roller Holder (Part# BS-58)
- ❖ Ink Rollers, 15mm (Part# IT-IR-15-BLK)
- ❖ Groove (Trough) Sensor (BS#BS-65)
- ❖ Carbon Brush for Printer (BS#64)
- ❖ Philips Screwdriver
- ❖ Flat Screwdriver
- ❖ Allen Wrench (3mm and 5mm)
- ❖ Wrench

Quality Control Testing

Our band sealers are manufactured in a facility which is certified in accordance with ISO 9001:2008. In addition, we quality test all of our band sealers in our facility following a rigorous and exacting standards to ensure that the product you purchased is a high quality reliable machine.

✓ Steps	Description
	Inspect all wiring on the unit, nothing is loosely attached. Make sure all wires are connected correctly.
	Make sure all connections are tight and properly mounted. (Ex: PC Board, Relay)
	Check parts to ensure they are in proper working order (ex: wheels, belts, knobs, etc)
	CBS-880 only - Attach the conveyor to the body via the drive shaft (Part #40). Detach after testing.
	Turn on machine - start, seal, fan, printer Check all knobs to make sure they start and end in the correct position
	Make adjustments as necessary if there is any unusual noise. Noise should be under 80db.
	Check fan - There should be air coming out of the cooling blocks
	Check motor - motor brushes should be held in tightly
	Check conveyor belt to make sure the belt is running smoothly and evenly
	Run machine for at least 20 minutes - after the seal temperature has been reached, seal bag sample to ensure good quality seal
	<u>Band Sealers w/ Printing Option:</u>
	Printing - make sure ink heating block, ink printing wheel are at optimal heat temperature
	Sensor and Coding Seat - test the sensor and coding seat are working properly; make adjustments as necessary
	Clean machine
	Enter serial # of the unit in the manual
	Repackage sealer w/ QC form, sealed bag / printed sample and manual.

Date:

Technician:

