

ProDispense™

3A3469F
EN

Used to meter and dispense paints, coatings, solvents, water, and lubrication fluids. For professional use only.

Not approved for use in explosive atmospheres or hazardous locations.



Important Safety Instructions

Read all warnings and instructions in this manual. **Save these instructions.**

*See page 3 for approvals.
See page 5 for maximum working
fluid pressure and system component
information.*

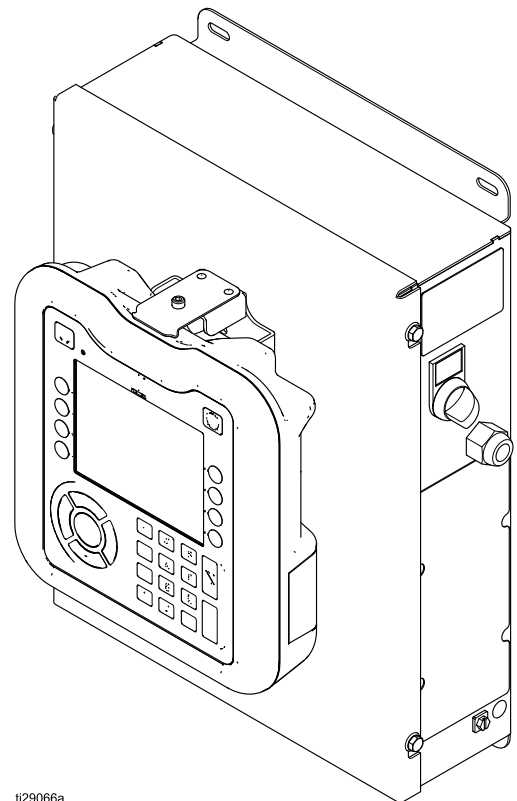

t129066a

Contents



Related Manuals	3	USB Download Procedure	42
Models	3	USB Upload Procedure	43
Automation Gateway Assemblies	4	Troubleshooting	44
Fluid Panel Kits	5	Fluid Panel	44
Warnings	6	Flow Meter	44
Important Isocyanate (ISO) Information	8	Dispense Valve	45
Overview	10	Recipe Troubleshooting	45
System Overview	10	Gateway Module	46
System Components	12	LED Diagnostic Information	46
Control Panel Assembly Overview	13	Errors	47
FCM	14	Maintenance	50
Control Gateway Modules (CGM)	15	Preventive Maintenance Schedule	50
ADM Display	16	Flushing	50
Fluid Panel Assembly Overview	17	Cleaning the ADM	50
Remote Operator Station	18	Software Installation and Update	51
Installation	19	Repair	53
Overview	19	Replace ADM	53
Communication Configuration	21	Replace Control Panel Power Supply	54
Install Control Panel	22	Replace Control Panel FCM	55
Install Fluid Panels	24	Replace Fluid Panel FCM	56
Install Cables	26	Replace Fluid Panel Junction Box	57
Install Fluid Supplies	27	Servicing Fluid Panel 26A129	59
Install Remote Operator Station	27	Servicing Fluid Panel 26A130	61
Grounding	27	Servicing Fluid Panel 26A131 or	
Check Resistance	27	26A165	63
Advanced Display Module (ADM)	28	Servicing Fluid Panel 26A132	65
ADM Keys and Indicators	28	Servicing Fluid Panel 26A071 and	
Soft Key Icons	29	26A247	67
Screen Icons	30	Parts	69
Navigating the Screens	31	Control Panel Parts	69
System Setup	32	Fluid Panel Parts	71
Brief Overview	32	Remote Operator Station Parts	85
Detailed Configuration Overview	33	Glossary of Terms	87
Operation	35	Technical Data	88
Pre-operation Checklist	35	California Proposition 65	91
Flush Before Using Equipment	35	Notes	91
Startup	35	Appendix A – Advanced Display Module (ADM)	
Dispense	37	Operation	93
Pressure Relief Procedure	39	Run Mode Screens	93
Shutdown	39	Setup Mode Screens	99
System Performance	40	Appendix B - System Design	114
Dispense Accuracy	40	Appendix C - Communications Gateway	
USB Data	41	Module	115
USB Logs	41	Install Fieldbus Connections	115
System Configurations Setting File	41	CGM I/O Data Map	119
Custom Language File	42	Commands	128

Related Manuals

The following is a list of component manuals written in English. These manuals and any available translations can be found at www.graco.com.

Manual No.	Description
308778	Volumetric Fluid Flow Meter, Instruction/Parts
308245	Electronic Pulse Meters, Instructions/Parts
313599	Coriolis Meter Kits, Instructions/Parts
306715	Dispensing Valve, Instructions/Parts
334183	Modbus TCP Gateway Module, Instructions/Parts
312864	Communications Gateway Module, Instructions/Parts
312493	Light Tower Kit, Instructions/Parts



Models

Part No.	Maximum Fluid Panels	Operating Voltage	Approvals
26A070	8	85–240 VAC, Single Phase	  Intertek 9902741 CSA STD C22.2 No. 14 UL STD 508A
26A071	—	—	
26A129	—	—	
26A130	—	—	
26A131	—	—	
26A132	—	—	
26A165	—	—	
26A247	—	—	

ProDispense Control Panel
 PART NO. SERIES
 VOLTAGE AMP
 120/240 1/.5

Read Instruction Manual



 GRACO INC.
 P.O. Box 1441
 Minneapolis, MN
 55440 U.S.A.
 Artwork No. 294553 Rev. C







 Intertek
 9902471
 Conforms to UL STD 508A
 Certified to CSA STD C22.2 No. 14

ProDispense Fluid Panel
 PART NO. SERIES
 MAX FLUID WPR MAX AIR WPR

Read Instruction Manual

 GRACO INC.
 P.O. Box 1441
 Minneapolis, MN
 55440 U.S.A.
 Artwork No. 294525 Rev. C

 Intertek
 9902471
 Conforms to UL STD 508A
 Certified to CSA STD C22.2 No. 14

Automation Gateway Assemblies

The control panel comes with one FCM installed. If an automation gateway is desired, it must be ordered separately. The automation gateway module is one of the Communications Gateway Modules (CGM). To order a CGM, see the following table. You will also need to order software upgrade token (17N369) There is room in the control panel for installation of one CGM or another FCM.

User Interface Description	Gateway Part Number to Order	Rotary Switch Position
DeviceNet™ (CGM)	CGMDN0	Any
EtherNet/IP™ (CGM)	CGMEP0	Any
PROFINET™ (CGM)	CGMPN0	Any
Modbus TCP	24W462	0 or 1

Fluid Panel Kits











NOTE: The fluid panel kit numbers are listed below.









Fluid Panel*	Maximum Working Pressure	Meter Description	K-factor (cc/pulse)	Includes:		
				Meter	Valve Type	Fluids Moved
26A129	2000 psi (13.8 MPa, 138 bar)	Graco lube meter; electronic pulse	5.48	26C765	solenoid	oil/lubricant
26A130	500 psi (3.4 MPa, 34 bar)	Water/ Antifreeze oil	2.82	26C766	solenoid	water/ antifreeze oil
26A131	3000 psi (21 MPa, 207 bar)	G3000	0.119	289813	205162, auto dispense; 116463, pneumatic solenoid	grease/paint
26A132	3000 psi (21 MPa, 207 bar)	HG6000; Helical gear with sensor	0.286	246190	205162, auto dispense; 116463, pneumatic solenoid	sealants paint
26A165	3000 psi (21 MPa, 207 bar)	S3000, solvent, low flow	0.061	258718	205162, auto dispense; 116463, pneumatic solenoid	solvent
26A071	3000 psi (21 MPa, 207 bar)	No meter	NA	none	205162, auto dispense; 116463, pneumatic solenoid	various lubes, paints, solvents
26A247	2300 psi (15.9 MPa, 158.5 bar)	Coriolis, 1.4 in. Cube Mass	0.062 default, configurable 0.020-0.200	16M519	205162, auto dispense; 116463, pneumatic solenoid	shear sensitive fiber-filled

* Remote operator station 26A133 can be used with any fluid panel. Ordered separately.

Warnings

The following warnings are for the setup, use, grounding, maintenance and repair of this equipment. The exclamation point symbol alerts you to a general warning and the hazard symbol refers to procedure-specific risks. When these symbols appear in the body of this manual or on warning labels, refer back to these Warnings. Product-specific hazard symbols and warnings not covered in this section may appear throughout the body of this manual where applicable.





 <h2 style="margin: 0;">WARNING</h2>	
   	<p>FIRE AND EXPLOSION HAZARD</p> <p>Flammable fumes, such as solvent and paint fumes, in work area can ignite or explode. Paint or solvent flowing through the equipment can cause static sparking. To help prevent fire and explosion:</p> <ul style="list-style-type: none"> • Use equipment only in well ventilated area. • Eliminate all ignition sources; such as pilot lights, cigarettes, portable electric lamps, and plastic drop cloths (potential static arc). • Keep work area free of debris, including solvent, rags and gasoline. • Do not plug or unplug power cords, or turn power or light switches on or off when flammable fumes are present. • Ground all equipment in the work area. See Grounding instructions. • Use only grounded hoses. • Hold gun firmly to side of grounded pail when triggering into pail. Do not use pail liners unless they are antistatic or conductive. • Stop operation immediately if static sparking occurs or you feel a shock, Do not use equipment until you identify and correct the problem. • Keep a working fire extinguisher in the work area.
    	<p>SKIN INJECTION HAZARD</p> <p>High-pressure fluid from dispensing device, hose leaks, or ruptured components will pierce skin. This may look like just a cut, but it is a serious injury that can result in amputation. Get immediate surgical treatment.</p> <ul style="list-style-type: none"> • Do not point dispensing device at anyone or at any part of the body. • Do not put your hand over the fluid outlet. • Do not stop or deflect leaks with your hand, body, glove, or rag. • Follow the Pressure Relief Procedure when you stop dispensing and before cleaning, checking, or servicing equipment. • Tighten all fluid connections before operating the equipment. • Check hoses and couplings daily. Replace worn or damaged parts immediately.

 <h1 style="margin: 0;">WARNING</h1>	
 	<p>ELECTRIC SHOCK HAZARD This equipment must be grounded. Improper grounding, setup, or usage of the system can cause electric shock.</p> <ul style="list-style-type: none"> • Turn off and disconnect power at main switch before disconnecting any cables and before servicing or installing equipment. • Connect only to grounded power source. • All electrical wiring must be done by a qualified electrician and comply with all local codes and regulations.
 	<p>TOXIC FLUID OR FUMES Toxic fluids or fumes can cause serious injury or death if splashed in the eyes or on skin, inhaled, or swallowed.</p> <ul style="list-style-type: none"> • Read SDSs to know the specific hazards of the fluids you are using. • Store hazardous fluid in approved containers, and dispose of it according to applicable guidelines. • Always wear chemically impermeable gloves when spraying, dispensing, or cleaning equipment.
	<p>PERSONAL PROTECTIVE EQUIPMENT Always wear appropriate personal protective equipment and cover all skin when spraying, servicing equipment, or when in the work area. Protective equipment helps prevent serious injury, including long-term exposure; inhalation of toxic fumes, mists or vapors; allergic reaction; burns; eye injury, and hearing loss. This protective equipment includes but is not limited to:</p> <ul style="list-style-type: none"> • A properly fitting respirator, which may include a supplied-air respirator, chemically impermeable gloves, protective clothing and foot coverings as recommended by the fluid manufacturer and local regulatory authority. • Protective eyewear, and hearing protection.
 	<p>EQUIPMENT MISUSE HAZARD Misuse can cause death or serious injury.</p> <ul style="list-style-type: none"> • Do not operate the unit when fatigued or under the influence of drugs or alcohol. • Do not exceed the maximum working pressure or temperature rating of the lowest rated system component. See Technical Data in all equipment manuals. • Use fluids and solvents that are compatible with equipment wetted parts. See Technical Data in all equipment manuals. Read fluid and solvent manufacturer's warnings. For complete information about your material, request SDS from distributor or retailer. • Do not leave the work area while equipment is energized or under pressure. • Turn off all equipment and follow the Pressure Relief Procedure when equipment is not in use. • Check equipment daily. Repair or replace worn or damaged parts immediately with genuine manufacturer's replacement parts only. • Do not alter or modify equipment. Alterations or modifications may void agency approvals and create safety hazards. • Make sure all equipment is rated and approved for the environment in which you are using it. • Use equipment only for its intended purpose. Call your distributor for information. • Route hoses and cables away from traffic areas, sharp edges, moving parts, and hot surfaces. • Do not kink or over bend hoses or use hoses to pull equipment. • Keep children and animals away from work area. • Comply with all applicable safety regulations.

Important Isocyanate (ISO) Information

Isocyanates (ISO) are catalysts used in two component materials.



Isocyanate Conditions

			
---	---	---	---

Spraying or dispensing materials that contain isocyanates creates potentially harmful mists, vapors, and atomized particulates.

- Read and understand the fluid manufacturer's warnings and safety data sheet (SDS) to know specific hazards and precautions related to isocyanates.
- Use of isocyanates involves potentially hazardous procedures. Do not spray with this equipment unless you are trained, qualified, and have read and understood the information in this manual and in the fluid manufacturer's application instructions and SDS.
- Use of incorrectly maintained or mis-adjusted equipment may result in improperly cured material. Equipment must be carefully maintained and adjusted according to instructions in the manual.
- To prevent inhalation of isocyanate mists, vapors, and atomized particulates, everyone in the work area must wear appropriate respiratory protection. Always wear a properly fitting respirator, which may include a supplied-air respirator. Ventilate the work area according to instructions in the fluid manufacturer's SDS.
- Avoid all skin contact with isocyanates. Everyone in the work area must wear chemically impermeable gloves, protective clothing, and foot coverings as recommended by the fluid manufacturer and local regulatory authority. Follow all fluid manufacturer recommendations, including those regarding handling of contaminated clothing. After spraying, wash hands and face before eating or drinking.

Keep Components A and B Separate

				
---	--	---	--	--

Cross-contamination can result in cured material in fluid lines which could cause serious injury or damage equipment. To prevent cross-contamination:

- **Never** interchange component A and component B wetted parts.
- Never use solvent on one side if it has been contaminated from the other side.

Moisture Sensitivity of Isocyanates

Exposure to moisture (such as humidity) will cause ISO to partially cure; forming small, hard, abrasive crystals, which become suspended in the fluid. Eventually a film will form on the surface and the ISO will begin to gel, increasing in viscosity.

NOTICE

Partially cured ISO will reduce performance and the life of all wetted parts.

- Always use a sealed container with a desiccant dryer in the vent, or a nitrogen atmosphere. **Never** store ISO in an open container.
- Keep the ISO pump wet cup or reservoir (if installed) filled with appropriate lubricant. The lubricant creates a barrier between the ISO and the atmosphere.
- Use only moisture-proof hoses compatible with ISO.
- Never use reclaimed solvents, which may contain moisture. Always keep solvent containers closed when not in use.
- Always lubricate threaded parts with an appropriate lubricant when reassembling.

NOTE: The amount of film formation and rate of crystallization varies depending on the blend of ISO, the humidity, and the temperature.

Changing Materials

NOTICE

Changing the material types used in your equipment requires special attention to avoid equipment damage and downtime.

- When changing materials, flush the equipment multiple times to ensure it is thoroughly clean.
- Always clean the fluid inlet strainers after flushing.
- Check with your material manufacturer for chemical compatibility.
- When changing between epoxies and urethanes or polyureas, disassemble and clean all fluid components and change hoses. Epoxies often have amines on the B (hardener) side. Polyureas often have amines on the A (resin) side.

Overview

System Overview

The ProDispense fluid metering system is a flexible electronic system that accurately dispenses preset amounts of fluids. It allows durable goods manufactures to quickly and accurately fill cavities with oil, grease, water or other industrial fluids. It can deliver from one to eight different fluids at multiple dispense points with accuracy up to +/-1%. Fluids can be configured to dispense independently or tied to recipes. They can be dispensed simultaneously or in defined sequences within recipes. The system can be configured to operate manually through user input or integrated into automation with available fieldbus gateway modules. Dispense results are tracked

and can be accessed from the control panel, USB download, or through a gateway module.

Typical Applications

- Oil dispense
- Lubricant dispense
- Paint dispense
- Antifreeze dispense
- Water dispense
- Sealant dispense
- Solvent dispense

Typical Installation - Single Fluid Panel

This is an example of what a system with a single fluid panel might look like. When designing a system, power consumption may be the limiting factor in the design of the system. Refer to [Appendix B - System Design, page 114](#) for additional guidance in designing a system.

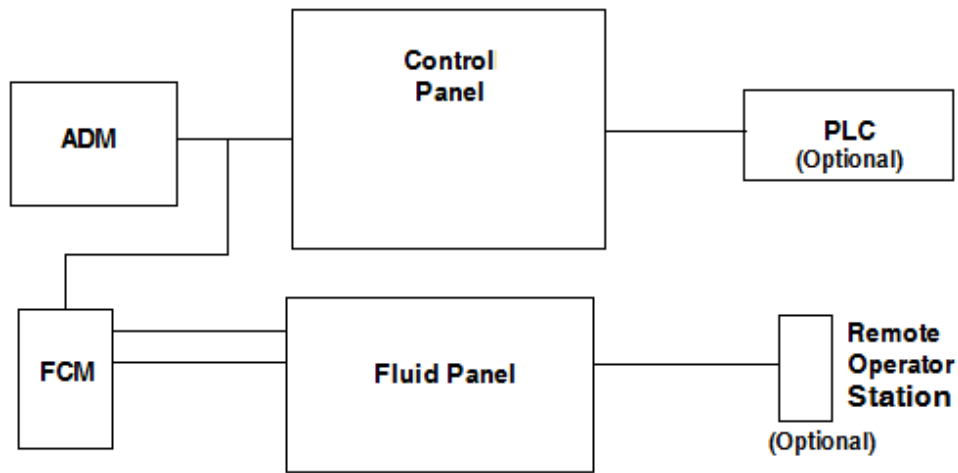

ADM – Advanced Display Module
FCM – Fluid Control Module
PLC – Programmable Logic Controller

Typical Installation - Multiple Fluid Panels

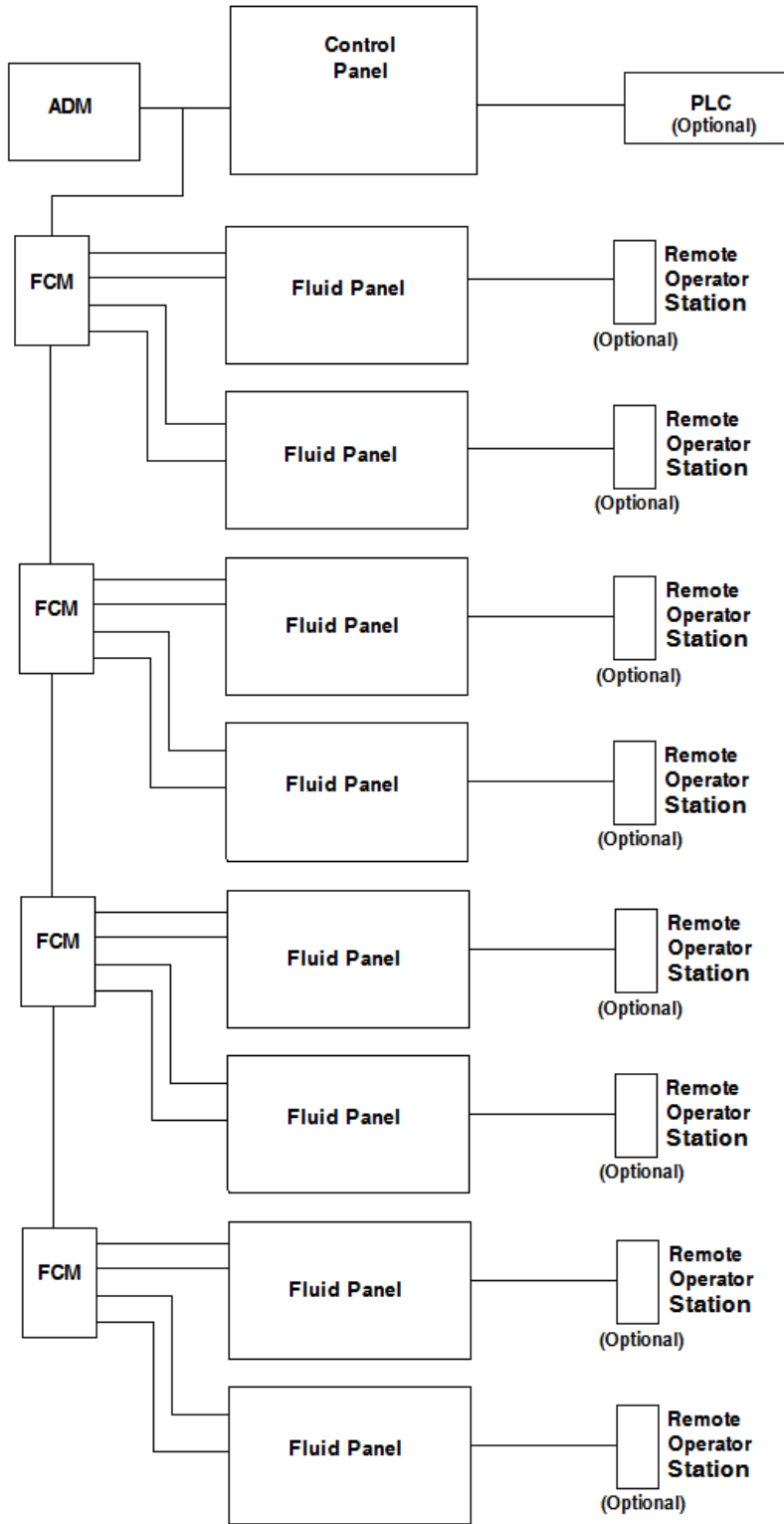

System Components

A single ProDispense system can be comprised of 1 fluid panel up to maximum of 8 fluid panels. A single system will require a control panel with ADM, an FCM, and a fluid panel. Other components such as the Remote Operator Station can be added for operator control, or control panel connection to a PLC through a communication network.

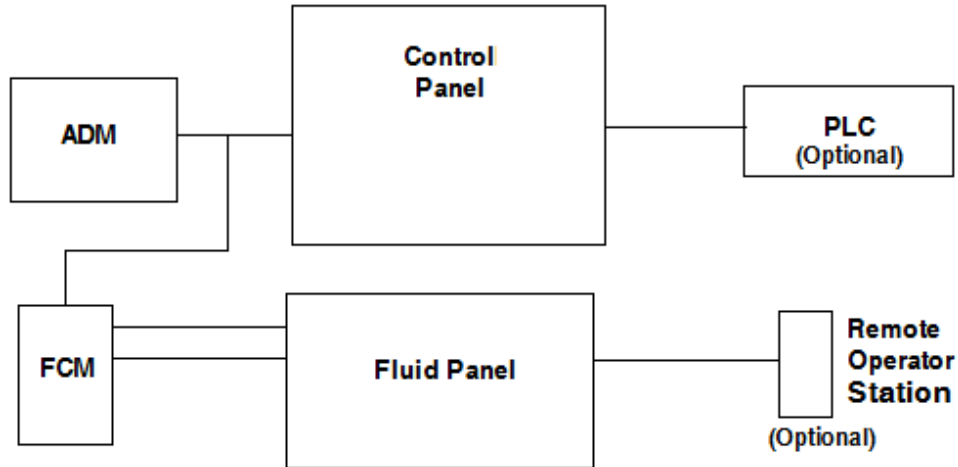

Control Panel (User Interface)

The control panel uses the Advance Display Module (ADM) to communicate with the fluid panel assembly to control fluid dispense operation.

The control panel receives operator or an automation controller (such as a PLC) input and uses this input to determine dispense activity for the fluid panel assembly.

Fluid Control Module (FCM)

Each FCM communicates with up to 2 fluid panels. The FCM receives communication from the control panel and delivers appropriate communications to the desired fluid panel. The FCMs are configured in a daisy-chain structure that will route communications through to the subsequent FCMs.

The control panel includes one FCM which comes installed in the control panel. Additional FCMs must be purchased separately.

For protection from the install environment and any potential exposure to undesirable materials, Graco recommends that additional FCMs be installed inside of the controller (if no CGM installed), or within one of the two fluid panels it connects with.

Fluid Panel Assembly

The fluid panel assembly contains components that control and monitor fluid dispensing. A fluid metering system can have up to 8 fluid panels, and simultaneously dispense a different fluid at each fluid panel.

Remote Operator Station

The remote operator station can be used by the operator at the location of the fluid panel to start or stop fluid dispensing,

Control Panel Assembly Overview

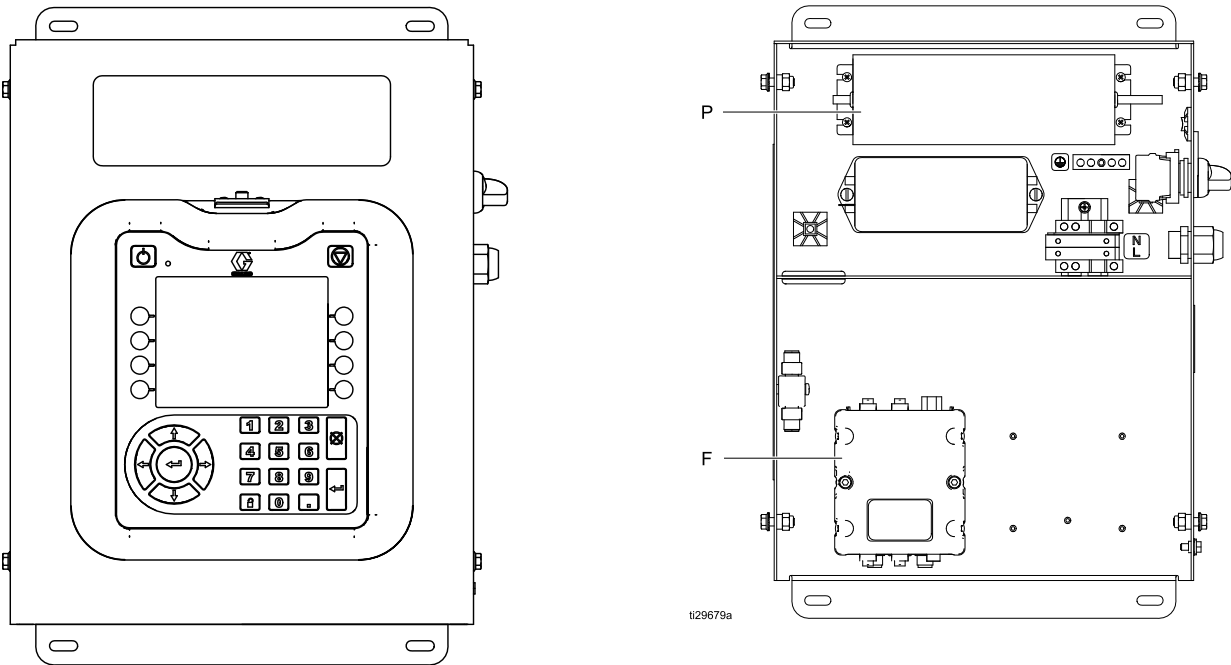

The control panel includes the following components:

- Advanced Display Module (ADM) with USB; see [ADM Display, page 16](#) for details.
- ADM mounting bracket.
- Power ON/OFF switch
- 24 VDC and 100-240 VAC power supply module (P).
- FCM (F).
- Additionally, space is available for mounting a second FCM or a Control Gateway Module (CGM).

FCM

The FCM provides the communication path between the control panel and the fluid panels. One FCM will accommodate 2 fluid panels.

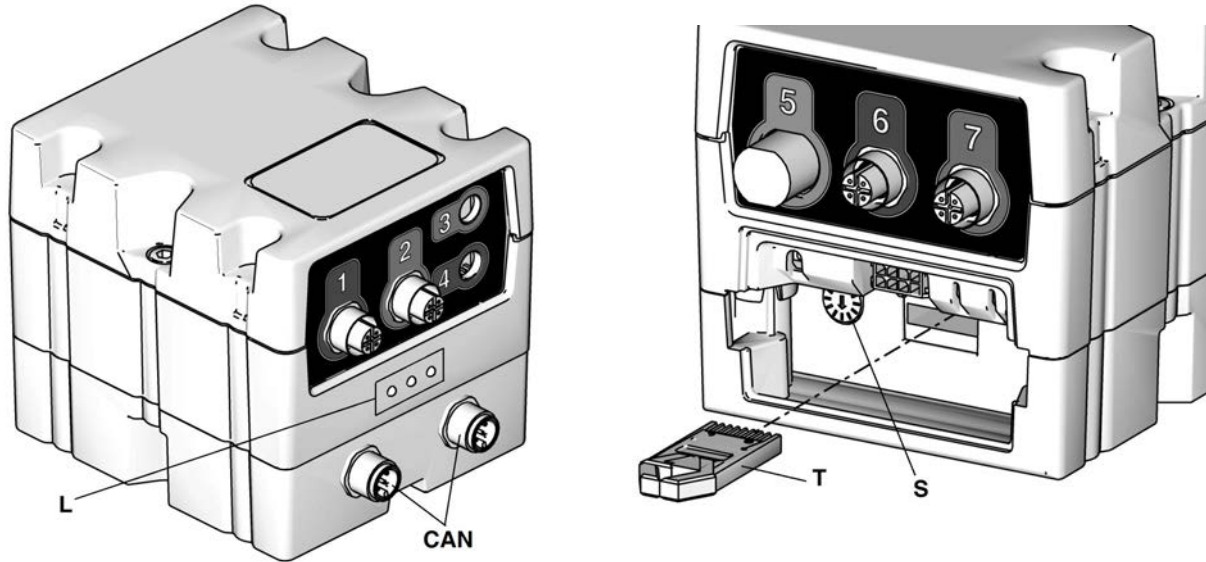

Connector No.	Function
1	Fluid panel 2 (Solenoid) – color code=red
2	Fluid panel 1 (Solenoid) – color code=blue
3	Fluid panel 1 (Meter) – color code=blue
4	Fluid panel 2 (Meter) – color code=red
5	Not used
6	Not used
7	Not used

CAN	Communication cable connections between control panel (ADM) and each FCM.	
Rotary Switch (S)	The rotary switch (S) on the FCM must be set to a valid position and each FCM must have a unique rotary switch position. The FCM rotary switch position determines which number to assign to that fluid panel.	
	Fluid panels	Rotary switch position
	0/1	0 (default)
	2/3	1
	4/5	2
	6/7	3
Status LEDs (L)	Refer to LED Diagnostic Information, page 46 for definitions of LEDs.	

NOTE: The token (T) is only required to update operation software. It must be removed for system operation. Token 17K873 is available separately. Token 17K873 is included in FCM and ADM replacement parts.

Control Gateway Modules (CGM)

Gateway modules can be mounted in the Control Panel for communication with an external control system, such as a PLC. A Gateway should be selected from the information below:

User Interface Description	Gateway Part Number	Rotary Switch Position
DeviceNet™	CGMDN0	Any
EtherNet/IP™	CGMEP0	Any
PROFINET™	CGMPN0	Any
Modbus TCP	24W462	0 or 1

FRONT VIEW

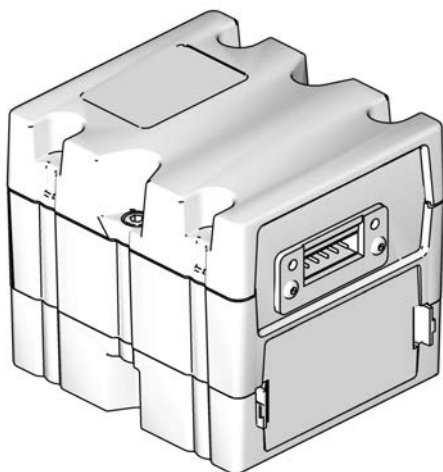

BACK VIEW

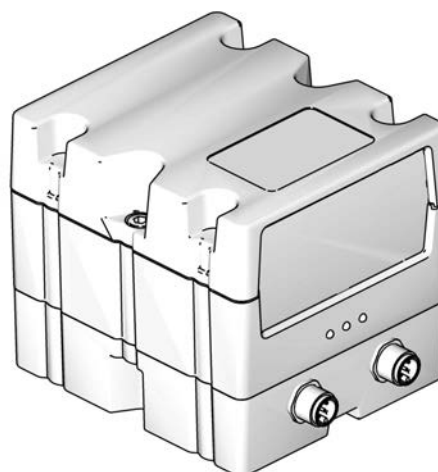

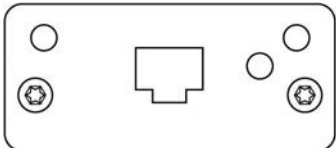
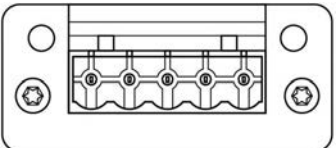
 <p>PROFINET or EtherNet/IP or Modbus TCP Connector</p>	 <p>DeviceNet Connector</p>
--	---

ADM Display

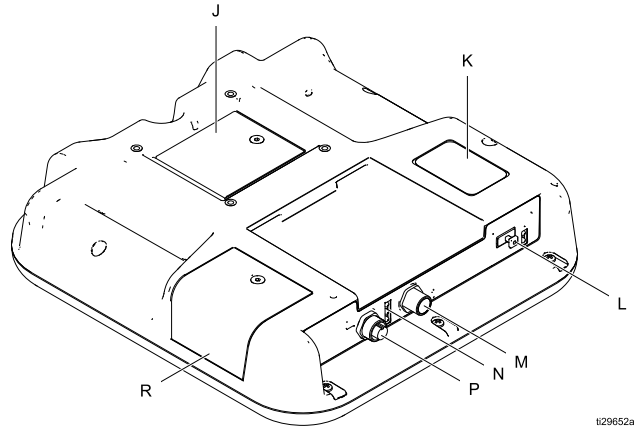
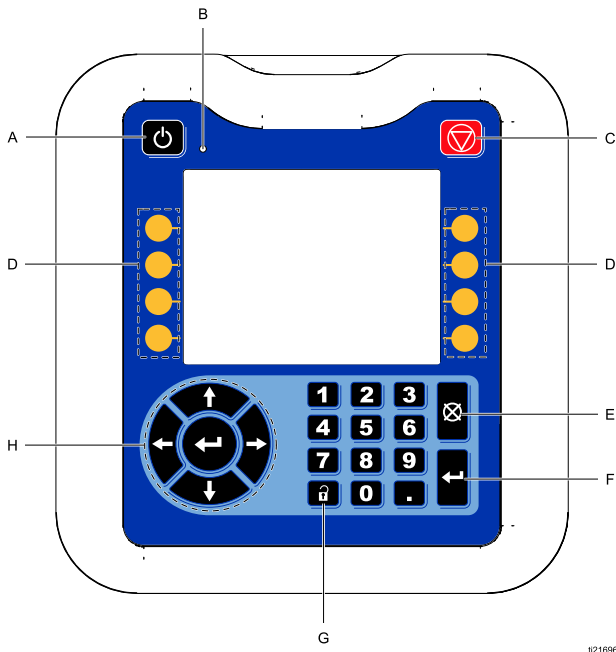

Key:

Callout	Function
A	Power On/Off Powers system on and off.
B	System Status Indicator LED Displays system status.
C	Stop Stop all system processes. However, it is not a safety or emergency stop.
D	Soft Keys Functions vary depending on selected screen.
E	Cancel Cancel a selection or number entry while in the process of entering a number or making a selection.
F	Enter Acknowledge changing a value or making a selection.
G	Lock/Setup Toggle between run and setup screens. If setup screens are password protected, button toggles between run and password entry screen, or current setup screen to the run screen.

Callout	Function
H	Navigation Navigate within a screen or to a new screen.
J	Battery Cover
K	Model Number Tag Model number
L	USB Module Interface USB port and USB indicator LEDs
M	CAN Connector Power connection
N	Module Status LEDs See for signal definitions.
P	Accessory Cable Connection
R	Token Access Cover

NOTICE

To prevent damage to the softkey buttons, do not press the buttons with sharp objects such as pens, plastic cards, or fingernails.

Fluid Panel Assembly Overview

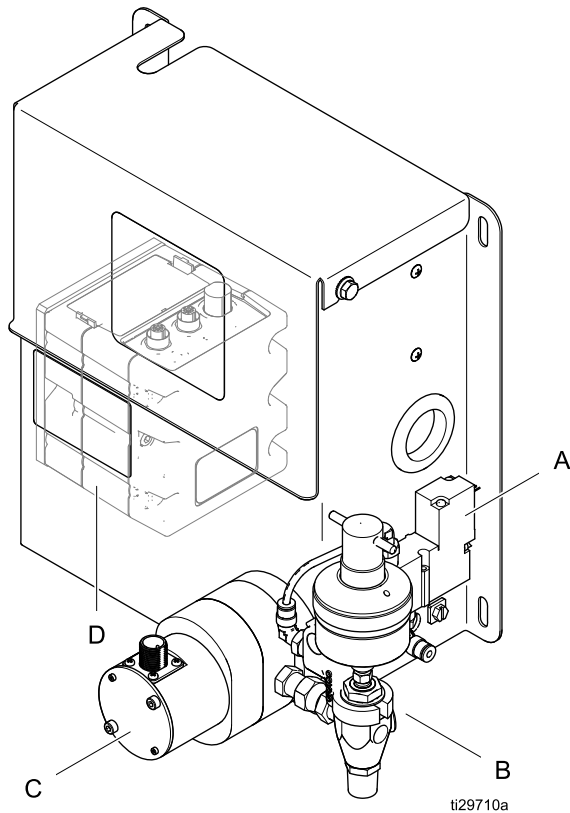

Fluid Panel Components

The fluid panel contains components to measure and dispense fluids and terminal connections for communication with the control panel. The main components of the fluid panel assembly include:

- Fluid flow meter (C) (optional)
- Solenoid valve (A) to control the dispense valve; may function as the dispense valve in some instances
- Dispense valve (B)
- FCM (D) for communication with the control panel; one FCM supports 2 fluid panels

Fluid Flow Meter

The fluid flow meter precisely measures the flow rate and volume of fluid dispensed. Offered meters installed on fluid panels include:

- G3000
- S3000
- HG6000
- Coriolis
- Water meter
- Oil meter

A meterless fluid panel is available to accommodate a customer-supplied fluid flow meter.

Dispense Valve

The dispense valve is set up to deliver the fluid at a precise flow rate while the solenoid valve is open.

Solenoid Valve

The solenoid valve enables/disables the activation of the dispense valve. When activated, the solenoid provides an air supply to the dispense valve which will then activate the dispense valve and allow fluid output from the dispense valve.

Some fluid panels contain a solenoid valve which is also the dispense valve. These valves are limited to use with some liquids which are low viscosity or are compatible with the materials which comprise the valve.

Remote Operator Station

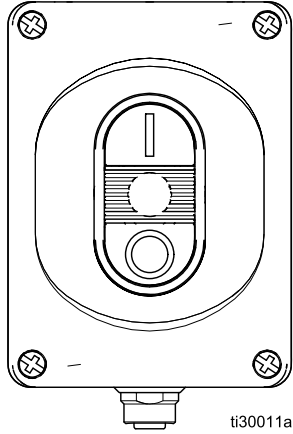

The remote operator station provides local control of a single fluid panel. The remote operator station can be mounted near the point of dispense for the connected fluid panel.

The remote operator station, part number 26A133 is ordered separately (kit includes a 50 ft [16 m] cable, PN 123659). A shorter cable (1.5 ft [0.5 m]), part number 122030, is available and is ordered separately.

Installation

Prior to Installation

- Have all system and component documentation available during installation.
- See component manuals for specific data on component requirements. Data presented here applies to a basic ProDispense system.
- Be sure all accessories are adequately sized and pressure-rated to meet system requirements.
- Use the ProDispense control panel with ProDispense fluid panel assemblies.

Overview

Figure 1 is not an actual system design. Contact your Graco distributor for assistance in designing your system.

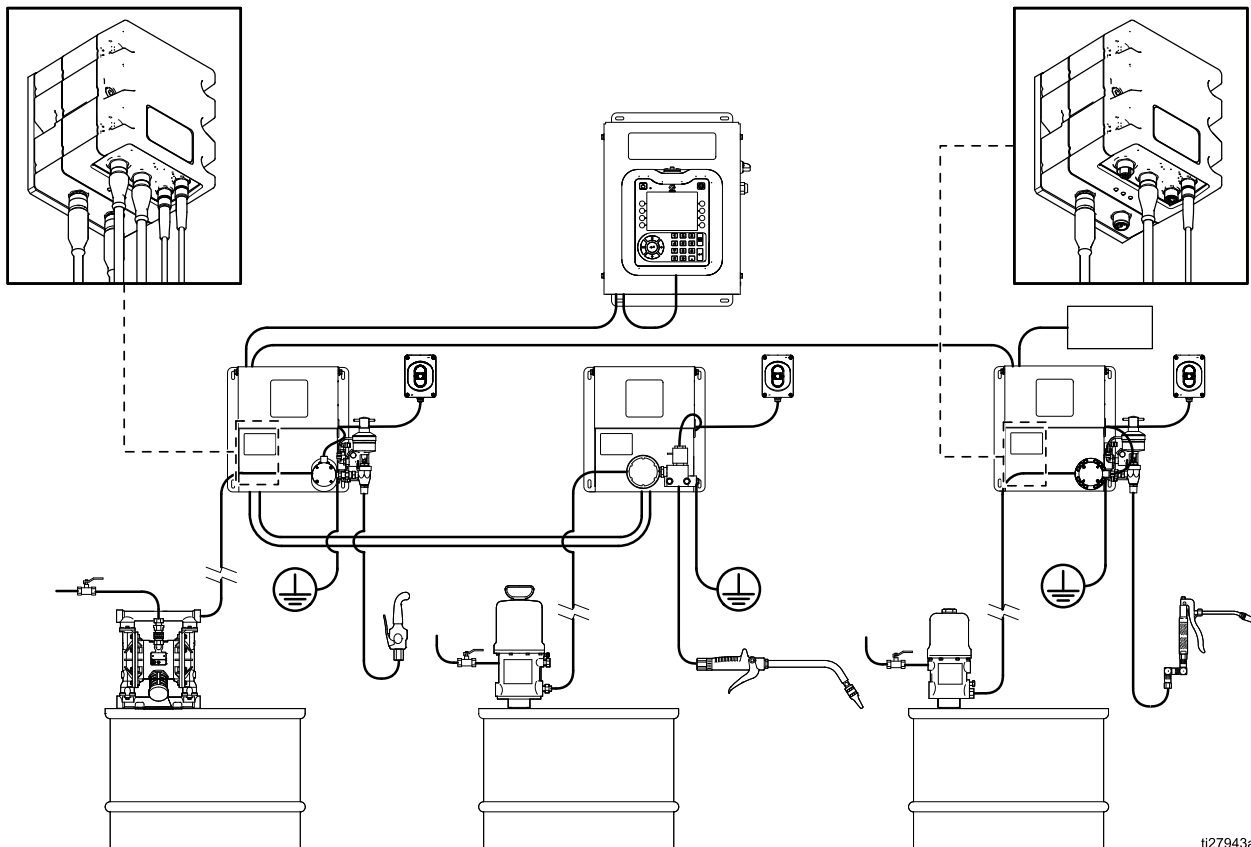

ti27943a

Figure 1 Sample ProDispense Installation

Installation

Component	Description
Fluid Control Modules (FCM)	<ul style="list-style-type: none"> • Fluid Control Module (FCM); up to four
Fluid Panels*	<ul style="list-style-type: none"> • Fluid Panels; up to two per FCM; up to eight total <ul style="list-style-type: none"> – Oil and Lubrication – Water and Antifreeze (not ETL listed) – Grease and Paint – Meterless (meter supplied by user)
Advanced Display Module	Use to set up, display, operate, and monitor the system. Use for daily functions including choosing recipes, reading/clearing errors, and placing the system in Diagnostic Mode. Locate in a non-hazardous area.
Remote Operation Station	Use for local control of one fluid panel.

* NOTE: Fluid Panels from earlier systems can be used if the junction box is upgraded (Kit 26A243) and the Operator Station is replaced with a Remote Operator Station (Kit 26A133).

The basic steps to install a system are shown below. See the separate component manuals for detailed information.

1. Mount the control panel.
2. *For systems with multiple fluid panels*, mount an FCM on one of each 2 fluid panels being used. See [Mount FCM in Fluid Panel, page 24](#).
3. Mount each fluid panel assembly.
4. Ground each fluid panel assembly.
5. Check ground continuity.
6. Connect fluid lines between each fluid panel and applicator. Connect fluid supply line and air supply to module.
7. Plumb air filter assembly near air supply drop site that will be used for fluid panel assembly.
8. Connect other fluid and air lines to additional system components as instructed in their manuals.
9. Install fluid panel and gateway cable assemblies.
10. Install Gateway interface.

Communication Configuration

When installing a system, each component requires communication cables. See the diagram below for sample configurations.

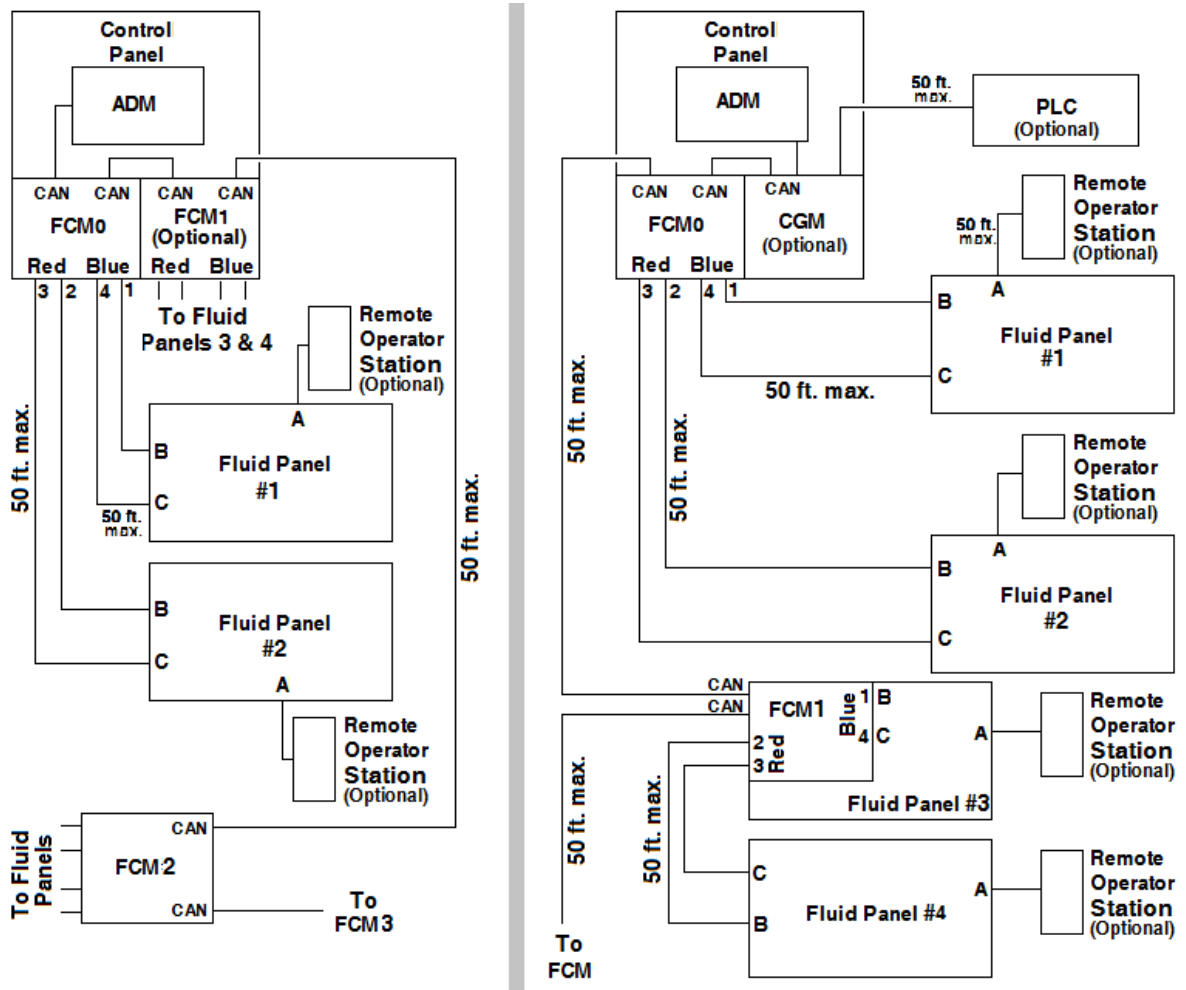

Typical Communication Connections

NOTE: The last FCM in the system must have the CAN termination resistor installed on the uncabled CAN connector to properly terminate the circuit. The termination resistor is installed on the FCM in the control panel in the factory. It will need to be relocated if additional FCMs are installed in the system.

Install Control Panel

Mount Control Panel

Ensure the following criteria are met before mounting the control panel:

- Select a location for the control panel that allows adequate space for installation, service, and use of the equipment.
- For best viewing, the ADM should be 60-64 in. (152-163 cm) from the floor.
- Ensure there is sufficient clearance around the control panel to run cables to other components.
- Ensure there is adequate access to an appropriate electrical power source. For example, the U.S. National Electric Code requires 3 ft (0.91 m) of space in front of the control panel.
- Ensure there is easy access to the power switch.
- Ensure the mounting surface can support the weight of the control panel and the cables attached to it.

Secure the control panel with appropriate size bolts (1/4 in. diameter) through each of the slotted mounting holes in the base plate.

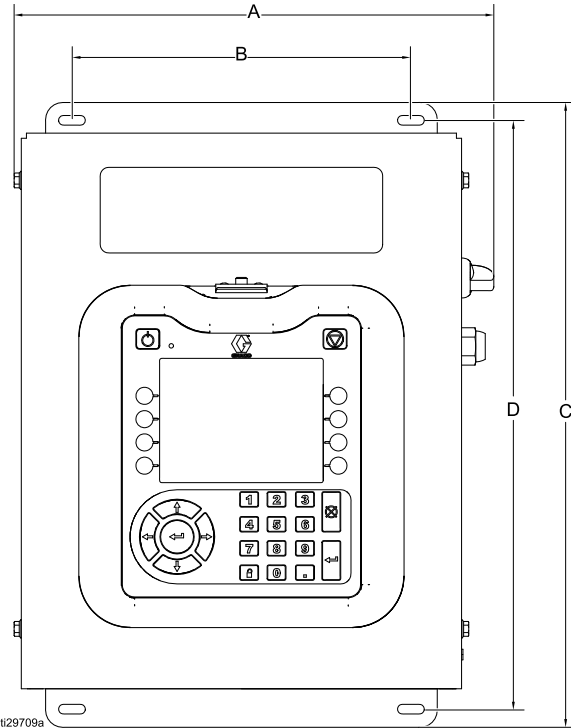

A	14 in. (356 mm)
B	9.9 in. (251 mm)
C	18.25 in. (464 mm)
D	17.2 in. (437 mm)
Slot width	0.28 in. (7 mm)

Electrical Connections

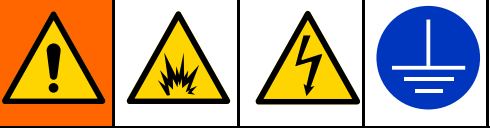

To reduce the risk of fire, explosion, or electric shock, when ensuring grounding, connecting cables, connecting to a power source or making other electrical connections:

- The control center must be electrically connected to a true earth ground; the ground in the electrical system may not be sufficient. Refer to your local code for the requirements for a “true earth ground” in your area.
- All wires used for grounding must be 18 AWG minimum.
- A qualified electrician must complete all grounding and wiring connections.
- Incoming power wiring must be guarded from the enclosure. Use a protective grommet or strain relief where the power wiring enters the enclosure to prevent wear.

NOTICE

If power and grounding connections are not done properly, the equipment will be damaged and the warranty voided.

Install Light Tower

The light tower accessory will provide a visual indication from a distance whether an abnormal condition exists within the system.

1. Order the 255468 Light Tower Accessory as a diagnostic indicator for the system.
2. Locate a mounting position near the control panel that is close enough to attach the cable to the ADM. Mount the light tower assembly at the mounting location.
NOTE: If an extension cable is needed to place the Light tower a further distance from the ADM location, the following cables can be ordered separately:
 - 122487, 5 ft (1.5 m)
 - 124003, 15 ft (5 m)
 - 121006, 150 ft (50 m)
3. Connect the cable from the light tower to the I/O port located on the bottom of the ADM.

Signal	Description
Green	No errors.
Yellow	An advisory exists.
Yellow flashing	A deviation exists.
Red solid	An alarm exists. One or more fluid panels may be shutdown.

NOTE: See [Errors, page 47](#) for error definitions.

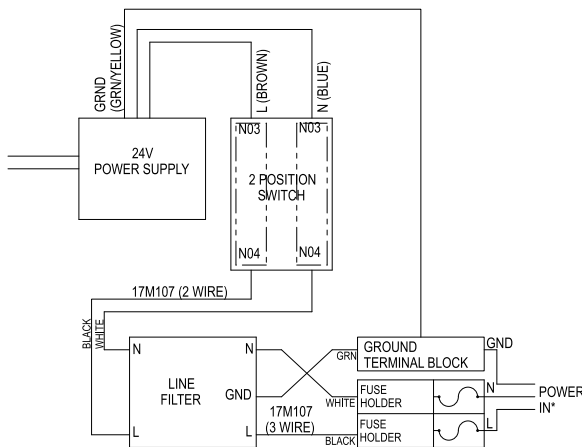
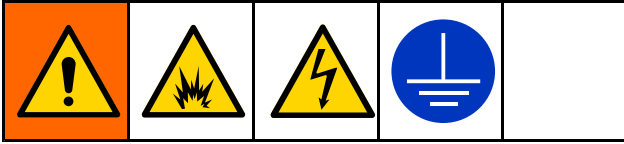

Figure 2 85-240 VAC Wiring

Install Fluid Panels



To install the fluid panel assemblies:

- Mount the fluid panel assemblies. See below.
- Ground the fluid panel assemblies. See [Ground Fluid Panel, page 26](#).
- Connect each fluid panel to the system. See [Install Cables, page 26](#).
- Connect fluid lines, air lines, and cables. See [Connect Air and Fluid Lines, page 26](#)

Mount FCM in Fluid Panel

Systems with more than 2 fluid panels require additional FCMs. Graco recommends mounting the additional FCMs within a fluid panel for protection from external sources. The FCM kit 26A134 includes a mounting plate which will make attachment to the fluid panel easier.

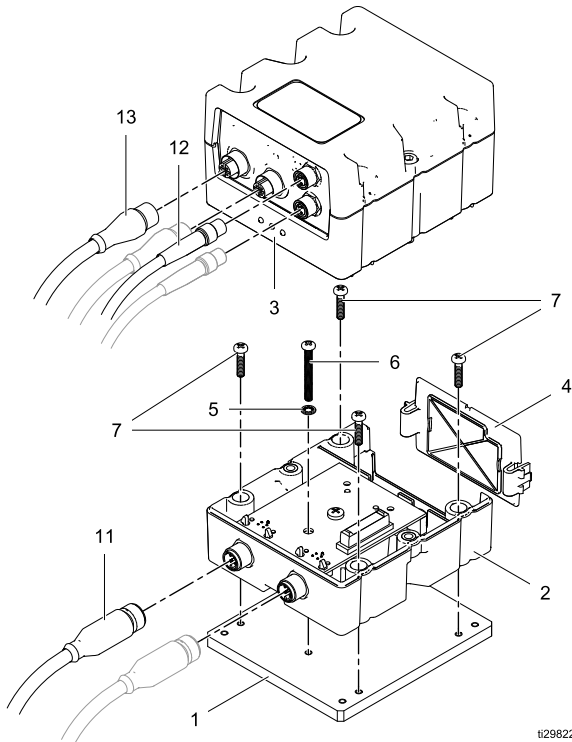

ti29822a

1. With the FCM open, using screw (6) and washer (5), insert the screw through the ground hole in the base (2) and attach loosely to the ground hole on the adaptor plate (1).
NOTE: Screws (7) do not have a lock washer attached to them. The screws with the attached lock washer are used to mount the adaptor plate to the fluid panel.
2. Loosely attach the four screws (7) through the base and into the threaded holes on the adaptor plate. Once all five screws are threaded into the adaptor plate, tighten screws to secure the base to the adaptor plate and the ground screw to make contact with the circuit board. Do not overtighten.
3. Position the adaptor plate and FCM (D) within the fluid panel as shown below. Align the unused adaptor plate holes with the mounting holes on the left side of the fluid panel. Loosely install the four screws with the attached lockwashers in each of the four holes and into the threaded holes on the adaptor plate. Once all screws are started, tighten to secure the adaptor plate to the fluid panel. Do not overtighten.

NOTE: If this FCM is not going to be connected to another FCM, the termination resistor must be installed on the uncabled CAN connector to properly terminate the circuit.

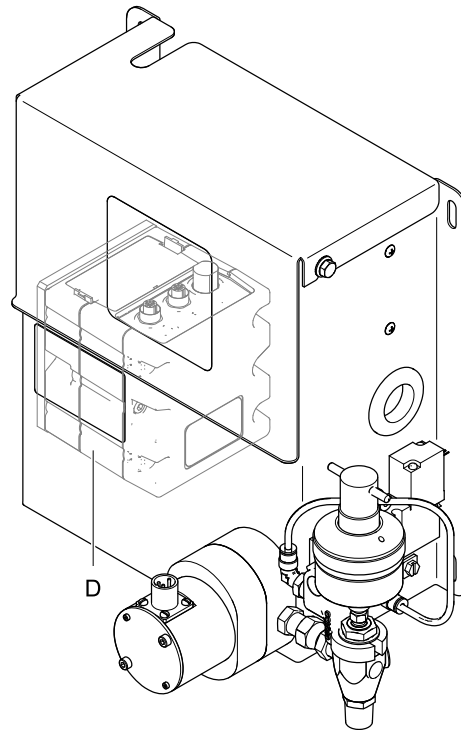

ti29710a_FCM

Before Mounting Fluid Panel

- See component manuals for specific information on component requirements. Information presented here pertains to the fluid panel only.
- Have all system and subassembly documentation available during installation.
- Be sure all accessories are adequately sized and pressure-rated to meet the system's requirements.
- Use only a Graco fluid panel with the control panel.

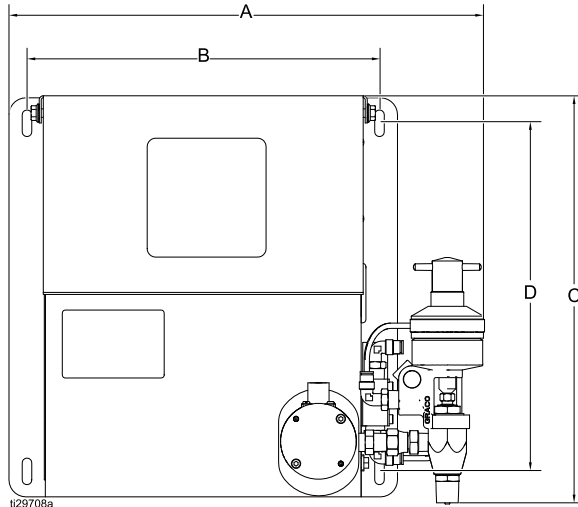

Mount Fluid Panels

1. Select a location for the fluid panel assembly. Keep the following in mind:
 - Allow sufficient space for installing the equipment.
 - Make sure all fluid lines, cables and hoses easily reach the components to which they will be connected.
 - Make sure the fluid panel provides easy access for servicing its components.
2. Mount and secure the fluid panel assembly to the mounting surface with appropriate size bolts (1/4 in. diameter) through each of the 4 slotted mounting holes of the base plate. The mounting hole dimensions are shown below.
3. On fluid panels 26A071 and 26A247, the tubing length between the solenoid air valve and the dispense valve must be less than, or equal to, 10 feet.

Panel	A	B	C	D	Slot width
26A129	11.4 in (290 mm)	10.4 in. (264 mm)	11.8 in (300 mm)	10.2 in. (259 mm)	0.28 in. (7 mm)
26A130	13.4 in (340 mm)	10.4 in. (264 mm)	11.8 in (300 mm)	10.2 in. (259 mm)	0.28 in. (7 mm)
26A131	14.5 in (268 mm)	10.4 in. (264 mm)	12.0 in. (305 mm)	10.2 in. (259 mm)	0.28 in. (7 mm)
26A132	15.0 in (381 mm)	10.4 in. (264 mm)	11.8 in (300 mm)	10.2 in. (259 mm)	0.28 in. (7 mm)
26A071	11.6 in (295 mm)	10.4 in. (264 mm)	11.8 in (300 mm)	10.2 in. (259 mm)	0.28 in. (7 mm)
26A247	11.6 in (295 mm)	10.4 in. (264 mm)	11.8 in (300 mm)	10.2 in. (259 mm)	0.28 in. (7 mm)
26A165	14.0 in (356 mm)	10.4 in. (264 mm)	12.0 in. (305 mm)	10.2 in. (259 mm)	0.28 in. (7 mm)
Coriolis Kit bracket	7.9 in (201 mm)	6.9 (175 mm)	9.7 in (246 mm)	8.7 in (221 mm)	0.38 in. (9.7 mm)

Convert Fluid Panels

If fluid panels used with a 244561 controller are going to be used with the 26A070 control panel, they will require a junction box upgrade so that the fluid panel is able to communicate with the 26A070 control panel. The junction box upgrade kit 26A243 can be ordered separately. The kit will upgrade one fluid panel junction box.

NOTE: Ensure that the power consumption of the older panels is taken into consideration prior to connection. See

[Appendix B - System Design, page 114](#) for information on available power and how to calculate the power consumption of the various system components. The requirement that one FCM can communicate with two fluid panels will also apply to the converted fluid panels. FCM kit 26A134 can not be mounted within converted fluid panels due to fluid panel size restrictions. From an FCM protection standpoint, consider combining one new fluid panel with one converted fluid panel on an FCM during the layout planning for your system.

Meterless Fluid Panel

Connection of a meter to a meterless panel will require attaching the meter wires into the fluid panel junction box. For information about the meter connections of all fluid panel meters, refer to the schematics shown in [Replace Fluid Panel Junction Box, page 57](#).

Ground Fluid Panel

Ensure that every fluid panel is appropriately grounded prior to operation. For grounding instructions, refer to [Grounding, page 27](#).

Connect Air and Fluid Lines

NOTICE

Route all fluid and air lines carefully. Avoid pinching and premature wear due to excessive flexing or rubbing. Hose life is directly related to how well they are supported.

Follow the instructions in your separate component manuals to connect air and fluid lines. The following are only general guidelines.

- The fluid panel assembly should be installed on the automation unit or in another appropriate place, as close as practical to the dispense location.
- Connect a fluid line between the fluid panel dispense valve and the dispense assembly. Smaller diameter and shorter fluid lines (hoses) will provide better fluid system response.
- Connect a fluid supply line to the flow meter fluid inlet.
- If required for the selected fluid panel, connect an air line to the solenoid on the fluid panel. Air must

be clean and dry, between 85-120 psi (0.59-0.82 MPa, 5.9-8.27 bar). Flush air line before plumbing in an air filter assembly. Plumb in air filter assembly near air drop site (upstream of fluid panel module). Adding an air regulator to this line will provide more consistent dispense valve response times.





NOTE: To maximize system performance keep the dispense hose length and ID as small as the application will allow.

Install Cables

NOTE: To prevent system errors, only connect cables with the power off. See [Communication Configuration, page 21](#) for cable connections.

1. For systems with more than two fluid panels: Use a CAN cable to connect the control panel FCM to another FCM. Use additional CAN cables to connect remaining FCMs together in sequence. Ensure each FCM rotary switch has been set to indicate its order within the system. See [FCM, page 14](#) for rotary switch settings and location of CAN connectors.
2. Connect cables from the control panel FCM blue (or red) connectors to fluid panel connectors A and C. If more than one fluid panel is being attached, repeat this step using the red (or blue) connectors to the second fluid panel.
NOTE: Each fluid panel must be configured on the Fluid screen to tell the system which color FCM connectors were used for that fluid panel. See [Fluid Screen, page 103](#).
3. For fluid panels which will have a Remote Operator Station installed, attach the remote operator station cable to fluid panel connector A.

Install Fluid Supplies

				
<ul style="list-style-type: none"> To reduce the risk of equipment overpressurization and rupture which can cause injury, including skin injection, do not exceed the pressure rating of the lowest rated system component. See the identification label for the maximum working pressure of the equipment. To reduce the risk of injury, including skin injection, you must install a shutoff valve between each fluid supply line and the meter. Use the valves to shut off fluid during maintenance and service. 				

ProDispense fluid panels can be supplied by pressure tanks, pail or drum pumps, or central recirculating lines.





The fluid supply must be free of pressure spikes, commonly caused by a pump stroke changeover. If necessary, install pressure regulators or a surge tank on the fluid supply outlets. Note that this will also reduce the fluid supply pressure.

Install Remote Operator Station

Mount the operator station in a convenient location for the operator. Connect the cable to the fluid panel junction box connector marked **C**.

NOTE: 20 ft. (6.1 m) station cable extension, 198456, is available.

Grounding

				
<p>This equipment must be grounded to reduce the risk of static sparking and electric shock. Electric or static sparking can cause fumes to ignite or explode. Improper grounding can cause electric shock. Grounding provides an escape wire for the electric current.</p>				

Control Panel: Connect a ground wire to the grounding lug on the bottom of the controller. Connect the other end of the ground wire to a true earth ground.

Fluid Panels: Connect a ground wire to the grounding lug on the junction box bracket. Connect the other end of the ground wire to a true earth ground.



Feed Pumps or Pressure Pots: See your separate pump or pressure pot manual.

Air and Fluid Hoses: Use only grounded hoses.

Fluid Supply Container: Ground the container according to your local code.

Solvent Pails Used when Purging: Ground pails according to your local code. Use conductive, metal pails, placed on a grounded surface. Do not place pails on nonconductive surfaces, such as paper or cardboard.

Check Resistance

				
<p>To reduce the risk of fire, explosion, or electric shock, the resistance between the ProDispense components and true earth ground must be less than 1 ohm.</p>				



Check the resistance between each ProDispense component and true earth ground. If the resistance is 1 ohm or greater, a different ground site may be required. Do not operate the system until the problem has been corrected.





Advanced Display Module (ADM)

ADM Keys and Indicators

The ADM display shows graphics, text, information related to setup, and operational details.

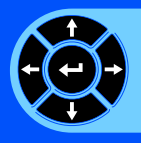
NOTICE
To prevent damage to the softkey buttons, do not press the buttons with sharp objects such as pens, plastic cards, or fingernails.

Key	Function
 <p>Startup/Shutdown Key and Indicator</p>	<p>Press to startup or shutdown the system.</p> <ul style="list-style-type: none"> • Solid green indicates that system is in Standby (Ready) mode. • Solid yellow indicates that system is off. • Blinking green or yellow indicates that the system is in Setup mode.
 <p>Stop</p>	<p>Press to immediately stop the system and fluid dispense on all fluid panels.</p>
 <p>Soft Keys</p>	<p>Press to select the specific screen or operation shown on the display directly next to each key. The top left soft key is the Edit key, which allows access to any settable fields on a screen.</p>











Key	Function
 <p>Navigation Keys</p>	<ul style="list-style-type: none"> • <i>Left/Right Arrows:</i> Use to move from screen to screen. • <i>Up/Down Arrows:</i> Use to move among fields on a screen, items on a dropdown menu, or multiple screens within a function.
<p>Numeric Keypad</p>	<p>Use to input values. See ADM Display, page 16.</p>
 <p>Cancel</p>	<p>Use to cancel a data entry field.</p>
 <p>Setup</p>	<p>Press to enter or exit Setup mode.</p>
 <p>Enter</p>	<p>Press to choose a field to update, to make a selection, to save a selection or value, to enter a screen, or to acknowledge an event.</p>

Soft Key Icons

The following icons appear in the ADM display, directly to the left or right of the soft key which activates that operation.

NOTICE

To prevent damage to the softkey buttons, do not press the buttons with sharp objects such as pens, plastic cards, or fingernails.

Key	Function
	Enter Screen Press to enter screen for editing. Highlights editable data on a screen. Use Up/Down arrows to move between data fields on the screen.
	Exit Screen Press to exit screen after editing.
	Cancel <ul style="list-style-type: none"> • Home Screen - Press to cancel current recipe dispense. • Calibration screen - Press to cancel calibration procedure.
	Run/Start <ul style="list-style-type: none"> • Home Screen - Press to start recipe dispense. • Calibration screen - Press to start calibration procedure.
	Counter Reset Press to reset the current usage counter.
	Move Cursor to Left Appears on the User ID Keyboard screen. Use to move cursor to the left.
	Move Cursor to Right Appears on the User ID Keyboard screen. Use to move cursor to the right.
	Erase All Appears on the User ID Keyboard screen. Use to erase all characters.
	Backspace Appears on the User ID Keyboard screen. Use to erase one character at a time.
	Upper Case/Lower Case Appears on the User ID Keyboard screen. Use to change case (upper/lower).

Screen Icons

As you move through the screens, you will notice that icons are used frequently to simplify global communication. The following descriptions explain what each icon represents.

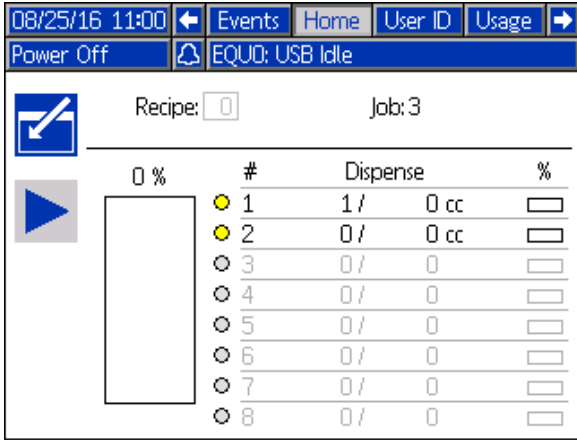

Key	Function
	User ID
	Recipe Number
	Date
	Time
	Job Number
	Volume
	Fluid Number
	Alarm
	Deviation
	Advisory
	Progress Bar
	Fluid Progress
	Fluid Panel Status

Navigating the Screens

Screen navigation will depend on using various keys on the ADM. As the various screens appear, the menu bar above them will indicate a variety of information. The menu bar is shown below.



There are two sets of screens:

- The Run screens control dispensing operations and display system status and data.
- The Setup screens control system parameters and advanced features.

Press  on any Run screen to enter the Setup screens. If the system has a password lock, the Password screen displays. If the system is not locked (password is set to 0000), System Screen 1 displays.

Press  on any Setup screen to return to the Home screen.

Press the Enter soft key  to activate the editing function on any screen.

Press the Exit soft key  to exit any screen.

Use the other softkeys to select the function adjacent to them.

System Setup

Brief Overview

The first step in performing system setup is to define how the system will be configured. The manner in which fluids will be dispensed can vary for each type of fluid. Some fluids may be dispensed entirely by the use of a recipe, only when an operator triggers the fluid dispense, or by either method. The table below explains these dispense modes and a short version of the System Setup Sequence. For a more detailed overview of the setup steps, see [Detailed Configuration Overview, page 33](#).

Configura- tion	Description	Setup Sequence (Short version)
Recipe Mode	The recipe controls the order of fluid dispenses, defines the amount of fluid to be dispensed to a very precise amount, and does not require operator actions at a fluid panel to dispense the fluid.	<ul style="list-style-type: none"> • Install system components. • Establish fluid supplies and connect to fluid panels. <p>NOTE: For detailed operating instructions for use of the ADM, see ADM Display, page 16 and Appendix A – Advanced Display Module (ADM) Operation, page 93.</p> <ul style="list-style-type: none"> • At the ADM, configure system. See Setup Mode Screens, page 99. • Configure fluid panels. See Fluid Screen, page 103. • Set up Maintenance Schedule/Parameters for each fluid panel. See Setup Maintenance Schedule / Parameters, page 108. • Configure Gateway Settings. See Gateway Screen, page 109. • Set up recipes. See Recipe Screen, page 100. Setup guidelines and an example recipe can be found at Setup Recipes, page 101 • Configure Advanced Settings. See Advanced Screen 1, page 112. • Calibrate each fluid panel. See Calibration Procedure, page 106.
Station Mode	The timing of fluid dispensed at each fluid panel is not controlled by the ADM. Dispensing occurs when an operator at a fluid panel activates the dispense with the Remote Operator Station.	
Combination Mode	A recipe is created that will dispense fluids from some fluid panels automatically, in a given sequence, while other fluid panels are entered in the recipe as being in station mode. The fluid panels being operated in station mode require operator action to dispense.	

Detailed Configuration Overview

Initial configuration will involve settings that will not change once the system is placed into operation. The system configuration includes the following:

System settings — These are used to define the number of fluids used in the system, as well as activating the diagnostic mode. Activation of diagnostic mode will display a flow rate instead of a progress bar on the Run screen.

Advanced settings — These are used to configure the language, set the time, define a password, establish the units of measure, and USB settings. Installed system and component software versions are also found on the Advanced screens.

For detailed information about available settings, see [Advanced Screen 1, page 112](#) through [Advanced Screen 4, page 113](#).

Configure fluid panels — Each fluid panel needs definition for the panel address, hardware configuration, operation mode, and presets.

For detailed information about fluid panel configuration screen fields, see [Fluid Screen, page 103](#).

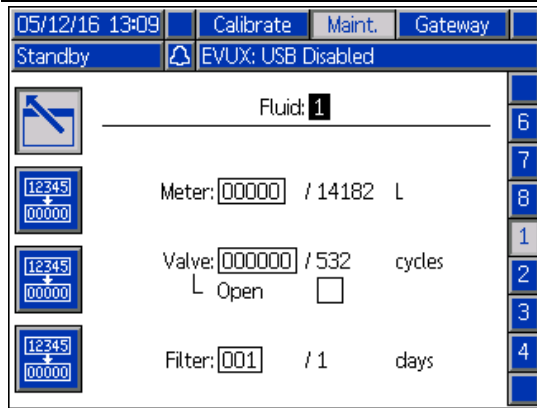

Define maintenance alarm parameters — The ProDispense system has the ability to monitor each fluid panel for the volume of liquids that have been metered, the number of times the dispense valve has cycled, and the number of days that have elapsed since the meter filter has been checked.

For detailed maintenance alarm parameters, see [Maintenance Screen, page 107](#).

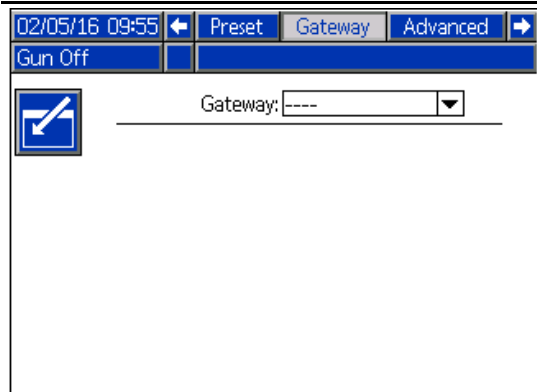

Configure gateway — The gateway configuration screens are used to configure the fieldbus gateways. The ProDispense system supports the following types of gateway:

- Modbus TCP
- Ethernet/IP
- PROFINET
- DeviceNet

For a detailed step-by-step gateway configuration, see [Gateway Screen, page 109](#).

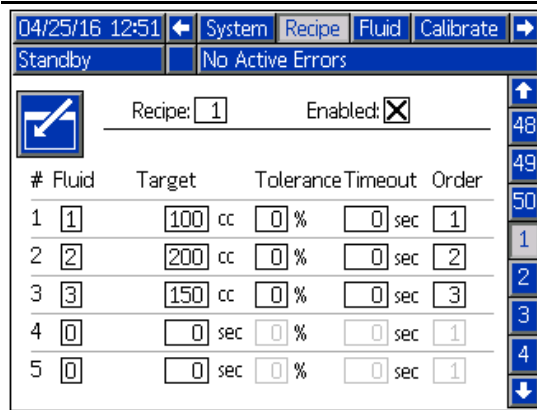

Configure recipes — The ProDispense system has the ability to handle up to 50 recipes. Each recipe can contain up to 10 preset items, which appear on 2 separate screens for each recipe. When defining a recipe, the preset items do not require sequential or contiguous entries.

For detailed step-by-step recipe setup, see [Setup Recipes, page 101](#).

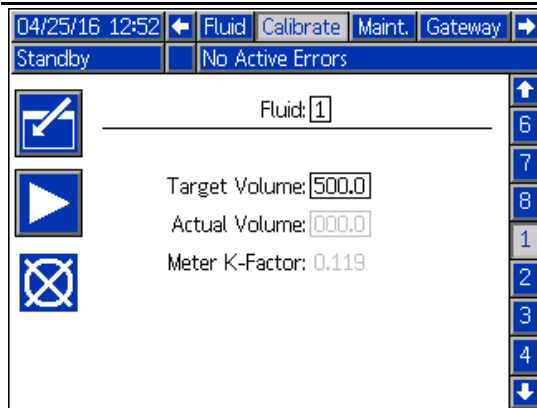

Calibrate fluid panel — After a fluid panel is configured, it is necessary to calibrate the fluid output to ensure accurate dispensing.

See [Calibration Procedure, page 106](#).

Operation

During normal operation, the system can dispense recipe presets or individual dispenses when it receives a command from the control panel, a remote operator station, or an Automation source (PLC). The system operates using the concept of recipes using combined fluid panels, and can also function with each fluid panel being autonomous and providing individual fluid dispense.

For information regarding how to configure your system, see [System Overview, page 10](#) and [Detailed Configuration Overview, page 33](#).

The control panel operates using the concept of jobs. For a detailed explanation of jobs and how they work, see below. For a detailed explanation of recipes and how they work, see [Setup Recipes, page 101](#).

Pre-operation Checklist

Go through the Pre-Operation Checklist daily, before each use.

✓	Checklist
	System grounded Verify all grounding connections were made. See Grounding, page 27
	All connections tight and correct Verify all electrical, fluid, air, and system connections are tight and installed according to the Installation manual.
	Fluid supply containers filled Check component A and B and solvent supply containers.
	Solenoid pressure set 85-120 psi inlet air supply (0.59-0.82 MPa, 5.9-8.2 bar).

Flush Before Using Equipment

The pump fluid section was tested with lightweight oil, which is left in the fluid passages to protect parts. To avoid contaminating your fluid with oil, flush the equipment with a compatible solvent before using the equipment.

Startup

Follow this procedure to start the ProDispense system for the first time (initial startup) or after the system has been shut down.

1. Turn on the power. The ProDispense system startup screen will display while the system is starting, then the Run screen or System Startup screen will appear, depending on the mode of operation the system is in.
2. If this is the initial startup, change to the Setup Mode and complete the setup procedures.
3. Change to the Dispense Mode Run screen if you are not there already.
4. Make sure the dispense lines run into the proper reservoir.
5. Load the fluids.

Loading Fluid Lines

NOTE: This procedure is performed for a single fluid. Repeat as necessary for additional fluids.

1. Ensure that the following conditions exist prior to loading a fluid:
 - a. The supply line has been flushed to remove any contaminants.
 - b. The fluid line contains only fluids or solvents which are compatible with the fluid being loaded.
 - c. The supply line has been pressurized.
2. On the ADM, navigate to the Maintenance Screen.

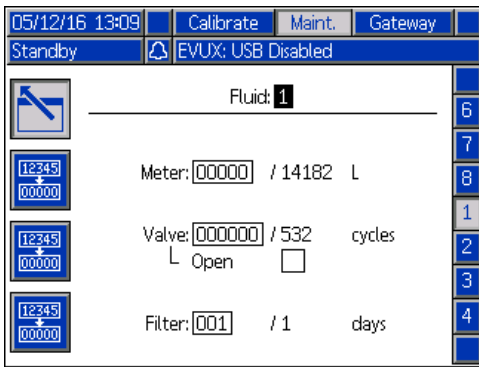

3. Select the desired fluid.
4. **NOTE:** If the dispense location has an applicator which must be triggered for fluid to dispense, this step can be performed after step 5. At the dispense location, place the dispense line (or direct the dispense valve) into a waste container.
5. On the Maintenance screen, select the Open checkbox. The dispense valve on the selected fluid panel is now open.
6. At the dispense applicator, dispense fluid into the waste container until a desired fluid dispense is achieved. If possible, stop the dispense applicator.
7. At the ADM, uncheck the Open checkbox. The fluid panel dispense valve is now closed.

Purging Fluid Lines

<p>This equipment stays pressurized while purging fluid lines. To help prevent splashing fluid, operate the equipment at the minimum pressure necessary to purge the fluid lines.</p>				

NOTE: This procedure is performed for a single fluid. Repeat as necessary for additional fluids.

1. Ensure that the following conditions exist prior to purging a fluid:
 - a. The supply line has been connected to a compatible solvent supply.
 - b. The fluid line pressure is at a low level to minimize splashing.
2. At the dispense location, direct the fluid outlet into a grounded metal pail.
3. On the ADM, navigate to the Maintenance Screen.

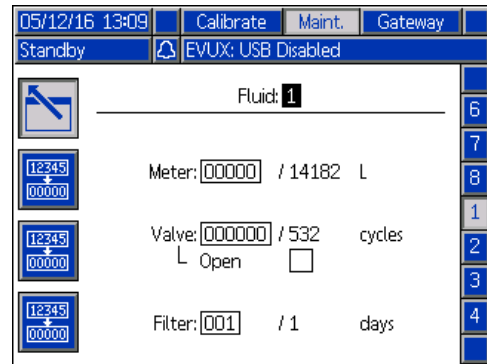

4. Select the desired fluid.
5. Select the Open checkbox. The dispense valve on the selected fluid panel is now open.
6. At the dispense location, dispense fluid into the waste container until fluid lines are clear. If possible, stop the dispense applicator.
7. At the ADM, uncheck the Open checkbox. The fluid panel dispense valve is now closed.

NOTE: If this fluid will be changed over to a different type of fluid, ensure that the new fluid will be compatible with the solvent currently in the supply line. If it is not compatible, purge the line again with a solvent that will be compatible with the new fluid to be used.

Dispense

Fluid dispensing occurs under the following conditions:

- Station dispense
- Top off
- Recipe dispense

Station Dispense

In station mode the fluid dispense presets are loaded using the fluid screen. See [Fluid Screen, page 103](#). Dispense activity is controlled by the Remote Operator Station connected to the fluid panel. The action that will be performed by the stop button of the Remote Operator Station must also be defined on the fluid screen.

By configuring the Top Off field on the fluid screen, it is possible to allow additional fluid, in excess of the target volume. This field does not limit the amount of fluid, but does limit the amount of time after the target volume is reached to dispense additional fluid.

1. Navigate to the ADM Home screen. Observe that the desired fluid has the desired target volume displayed for the desired fluid.
NOTE: Verify that the Remote Operator Station operation is understood before starting the dispense. The stop button may not allow pausing the dispense.
2. At the fluid panel Remote Operator Station, use the start and stop buttons to achieve the desired volume dispense.

Top Off

If the top off feature is configured for a fluid panel operating in station mode, (see [Setup Recipes, page 101](#) and [Fluid Screen, page 103](#)) after initial target dispense is complete, the Remote Operator Station LED will indicate that the fluid panel is in the top off state (see LED information in [Remote Operator Station Operation, page 38](#)). During the top off time, the operator can use the Remote Operator Station buttons to resume, pause or stop fluid dispense at this fluid panel. If the top off timer is reached, the Remote Operator Station LED will extinguish and no further fluid can be dispensed until a new recipe is started.

Top off volume is accounted for in the current job log.

Recipe Dispense

In recipe the dispense presets and operation is controlled by the control panel. See [Setup Recipes, page 101](#) for instruction in creating a recipe. To initiate a defined recipe, on the ADM, navigate to the Home screen, select the desired

recipe, and press the  key.

The recipe will begin dispensing on any fluid panels which are in recipe mode. If a fluid panel is encountered which is in station mode and has not been configured as independent station dispense (Order = 0), the recipe is placed in pause and the indicator light on the Remote Operator Station will light, indicating to the operator that the fluid can now be dispensed by pressing the start (1) button on the Remote Operator Station. The Remote Operator Panel stop button (0) must also be used to indicate completion of the dispense. Depending on how the recipe is configured, this may require a single push (Stop btn. = standby) of the button, or pushing and holding for at least 2 seconds (Stop btn. = pause/standby).

Fluid panels which are in station mode and have been configured in the recipe for independent station dispense (Order=0) are able to dispense fluids independent of how other fluids are dispensed in the recipe. The independent fluid panel in station mode is also able to dispense without regard to quantities or frequency stated in the recipe.

Status Indication

Station and recipe dispense progress can be observed on the home screen. Each fluid dispense progress is indicated individually by current over target dispense volumes and by progress bar.

If the system is dispensing a recipe, the Home screen displays the current recipe number and a progress bar indicates the overall progress of the dispensing recipe.

Job Records

A job record is generated after each successful station dispense with a unique job identifier. If the station dispense is part of a recipe, it is contained within that recipe job.

Station Dispense — In station dispense mode, each fluid panel dispense cycle is logged individually with a unique sequential job number for each dispense.

Recipe Dispense — In recipe mode all fluids that are part of recipe are logged with the same unique sequential job number that is associated with the whole recipe dispense. Stations which are configured

as independent dispense stations (Order = 0), will have their own job number identifiers.

Remote Operator Station Operation

The Remote Operator Station is used to control dispense operations at the fluid panel it is connected with. The Remote Operator Station functions in different manners, dependant on its operation mode. Some of the Remote Operator Station functions can be defined on the fluid screen. See [Fluid Screen, page 103](#).

Remote Operator Station Function	Dispense Mode	
	Station	Recipe
Start Button	Press to initiate fluid station dispense. LED will indicate dispense.	Press to start the recipe. This will only occur if the recipe is not currently running.
Stop Button	Press to pause or stop fluid dispense. For information about configuring the button function, see Fluid Screen, page 103 .	Terminate the current recipe without finishing.
LED	Lit during dispense. 2 blinks at end of dispense (100 ms @ 6.6 Hz) Short blinks when paused (100 ms @ 1 Hz) Short blinks during top off time (100 ms @ 1 Hz)	Lit during dispense.

Pressure Relief Procedure



Follow the **Pressure Relief Procedure** whenever you see this symbol.



This equipment stays pressurized until pressure is manually relieved. To help prevent serious injury from pressurized fluid, such as skin injection, and splashing fluid, follow the **Pressure Relief Procedure** when you stop spraying and before cleaning, checking, or servicing the equipment.

NOTE: Follow the additional instructions in brackets if a dispense valve is installed on the dispense line.

1. Shut off the fluid supply to the ProDispense fluid panel. Follow the **Pressure Relief Procedure** for the fluid supply system.
2. Place the dispense line [or direct the dispense valve] into a waste container.
3. Navigate to the Maintenance screen and select the desired fluid panel. To begin dispensing, select the Open checkbox [and trigger the dispense valve].
4. When fluid stops flowing and pressure is relieved, [release the dispense valve trigger and] deselect the Open checkbox to stop dispensing.
5. Repeat the process for each fluid panel as needed.
6. Shut off compressed air (if used) to each fluid panel.
7. Turn the main power switch on the control panel to the OFF position.

8. If you suspect the dispense valve tip or hose is clogged or that pressure has not been fully relieved:
 - a. **VERY SLOWLY** loosen the hose end coupling or a fitting on the dispense side of the dispense valve to relieve pressure gradually.
 - b. Loosen the nut or the coupling completely.
 - c. Clear the obstruction in the hose or tip.
 - d. If this does not remove the clog, cover the hose end coupling with a rag then very slowly loosen the hose end coupling to relieve pressure gradually, then loosen the coupling completely. Clear the valves or hose. Do not pressurize the system until the blockage is cleared.

Shutdown

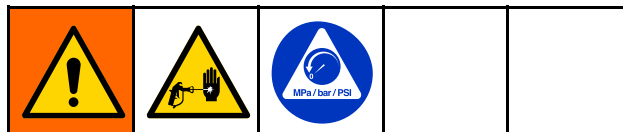

Follow this procedure before servicing the equipment and to avoid having fluid dry in the equipment and fluid lines when the equipment is not being operated.

1. On the ADM, press the  key.
2. Shut off the material supply to the fluid panel/meter.
3. Follow the [Pressure Relief Procedure, page 39](#).
4. Turn off the compressed air supply to the ProDispense system.
5. Turn off the ProDispense controller power switch.

System Performance

Dispense Accuracy

For the best accuracy and repeatability, follow the table below.

Dispense Parameter/Fluid Panel		Dispense Requirements		
Accuracy		1%	3%	5%
Minimum dispense time	26A071, 26A131, 26A132, 26A165, 26A247	3 sec	2 sec	2 sec
	26A129, 26A130	35 sec	30 sec	25 sec
Minimum dispense volume	26A165 (S3000, 0.020 cc/pulse)	3 cc	2 cc	2 cc
	26A247 (Coriolis, 0.062 cc/pulse)	7 cc	3 cc	2 cc
	26A131 (G3000, 0.119 cc/pulse)	12 cc	5 cc	3 cc
	26A132 (HG6000, 0.273 cc/pulse)	27 cc	10 cc	8 cc
	26A129 (Oil meter, 5.48 cc/pulse)	600 cc	200 cc	125 cc
	26A130 (Water meter, 2.82 cc/pulse)	300 cc	180 cc	60 cc
Maximum supply pressure variation		5%	10%	20%

Dispense Time

The longer the dispense time, the better the accuracy and repeatability. As the dispense time is lengthened, the flow rate decreases and the relationship between valve shutoff lag time and dispense time increases.

Meter Resolution

To determine dispense accuracy for a given flow meter, divide the dispense target volume by the K-Factor of the meter.
For example, 10 cc dose/0.119 K-Factor = 1.19% of dispense per pulse (84.03 pulses/dispense).

Dispense Volume

Minimum dispense volumes are calculated based on meter resolution. Larger dispense volumes will result in greater accuracy.

Flow Rate

Dispense flow rate should be tuned in relationship to dispense time and dispense volume.

$$\text{Flow rate} = \text{Volume} / (\text{Time} * 60) = \text{volume/minute}$$

Fluid Supply

Fluid viscosity consistency is required to maintain consistent dispense repeatability. When viscosity changes, flow rates change, resulting in dispense accuracy fluctuation.

USB Data

All files downloaded from the USB are put in a DOWNLOAD folder on the drive. For example: "E:\GRACO\12345678\DOWNLOAD"

The 8-digit numeric folder name matches the 8-digit ADM serial number. When downloading from multiple ADMs, there will be one sub-folder in the GRACO folder for each ADM.

USB Logs

During operation, ProDispense stores system and performance related information to memory in the form of log files. ProDispense maintains three types of log files: a job log, an event log, and dispense data logs. Follow the [USB Download Procedure, page 42](#), to retrieve log files.

Job Log

The job log file name is 2-JOB.CSV and is stored in the DOWNLOAD folder.

The job log maintains a record of the last 10,000 jobs. At the completion of each job the following data is stored in the log file:

- Date
- Time
- Job ID1, Job ID2, Job ID3
- Job Number
- Recipe
- Material
- Target
- Actual
- Error

Event Log

The event log file name is 1-EVENT.CSV and is stored in the DOWNLOAD folder.

The event log maintains a record of the last 1,000 events. Each event record in the log file contains the date and time the event occurred, the event type, event code, and event description.

System Configurations Setting File

The system configuration settings file name is SETTINGS.TXT and is stored in the DOWNLOAD folder.

A system configuration settings file automatically downloads each time a USB flash drive is inserted. Use this file to back up system settings for future recovery or to easily replicate settings across multiple ProDispense systems. Refer to the [USB Upload Procedure, page 43](#), for instructions on how to use this file.

It is recommended to retrieve the SETTINGS.TXT file after all system settings are set as desired. Store the file for future use as a backup in case the settings are changed and need to be quickly changed back to the desired setup.

NOTE: System settings may not be compatible between different versions of the ProDispense software.

NOTE: Do not modify the contents of this file.

Custom Language File

The custom language file name is DISPTEXT.TXT and is stored in the DOWNLOAD folder.

A custom language file automatically downloads each time a USB flash drive is inserted. If desired, use this file to create a user-defined set of custom language strings to be displayed within the ADM.

The ProDispense system is able to display the following Unicode characters. For characters outside of this set, the system will display the Unicode replacement character, which appears as a white question mark inside of a black diamond.

- U+0020 - U+007E (Basic Latin)
- U+00A1 - U+00FF (Latin-1 Supplement)
- U+0100 - U+017F (Latin Extended-A)
- U+0386 - U+03CE (Greek)
- U+0400 - U+045F (Cyrillic)

Create Custom Language Strings

The custom language file is a tab-delimited text file that contains two columns. The first column consists of a list of strings in the language selected at the time of download. The second column can be used to enter the custom language strings. If a custom language was previously installed, this column contains the custom strings. Otherwise the second column is blank.

Modify the second column of the custom language file as needed and then follow the [USB Upload Procedure, page 43](#), to install the file.

The format of the custom language file is critical. The following rules must be followed in order for the installation process to succeed.

- The file name must be DISPTEXT.TXT.
- The file format must be a tab-delimited text file using Unicode (UTF-16) character representation.
- The file must contain only two columns, with columns separated by a single tab character.
- Do not add or remove rows in the file.
- Do not change the order of the rows.
- Define a custom string for each row in the second column.

USB Download Procedure

Use the USB port on the ADM to download or upload data.

1. Enable USB downloads.
2. Remove the cover from the USB port on the bottom of the ADM. Insert the USB drive.
3. During the download, USB BUSY appears on the screen.
4. When the download is complete, USB IDLE appears on the screen. The USB drive may then be removed.

NOTE: If the download operation takes longer than 60 seconds, the message disappears. To determine if the USB is busy or idle, check the Error Status bar on the screen. If idle, remove the USB.

5. Insert the USB flash drive into the USB port of the computer.
 6. The USB flash drive window automatically opens. If it does not, open the USB flash drive from within Windows® Explorer.
 7. Open Graco folder.
 8. Open system folder. If downloading data from more than one system, there will be more than one folder. Each folder is labeled with the corresponding serial number of the ADM. (The serial number is on the back of the ADM.)
 9. Open DOWNLOAD folder.
 10. Open LOG FILES folder labeled with the highest number. The highest number indicates the most recent data download.
 11. Open log file. Log files open in Microsoft® Excel® by default if the program is installed. They also can be opened in any text editor or Microsoft® Word.
- NOTE:** All USB logs are saved in Unicode (UTF-16) format. If opening the log file in Microsoft Word, select Unicode encoding.
12. Always reinstall the USB cover after removing the USB, to keep the drive free of dirt and dust.

USB Upload Procedure

Use this procedure to install a system configuration file and/or a custom language file.

1. If necessary, follow the **USB Download Procedure**, to automatically generate the proper folder structure on the USB flash drive.
2. Insert the USB flash drive into the USB port of the computer.
3. The USB flash drive window automatically opens. If it does not, open the USB flash drive from within Windows Explorer.
4. Open the Graco folder.
5. Open the system folder. If working with more than one system, there will be more than one folder within the Graco folder. Each folder is labeled with the corresponding serial number of the ADM. (The serial number is on the back of the module.)
6. If installing the system configuration settings file, place SETTINGS.TXT file into UPLOAD folder.
7. If installing the custom language file, place DISPTXT.TXT file into UPLOAD folder.
8. Remove the USB flash drive from the computer.
9. Install the USB flash drive into the USB port of the ProDispense system USB port.
10. During the upload, USB BUSY displays on the screen. Wait for USB activity to complete.
11. Remove the USB flash drive from the USB port.

NOTE: If the custom language file was installed, users can now select the new language from the Language drop-down menu in the Advanced Setup Screen 1.

Troubleshooting

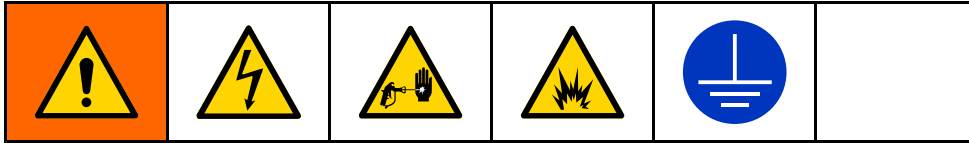

NOTE: Check all possible solutions in the chart below before you disassemble the system.

Fluid Panel

Problem	Cause	Solution
No outlet pressure or flow	Air pressure low	Verify air pressure is above 80 psi (551 kPa, 5.5 bar)
High outlet pressure	Supply pump pressure high	Service and adjust supply pressure
Air leaks from fluid plate	Loose air connections	Check air connections; tighten if necessary
	Worn gaskets	Check/replace gaskets on solenoid valve

Flow Meter

Problem	Cause	Solution
False measurement	Flow meter not calibrated	Calibrate flow meter, Calibrate Screen, page 106
	System not grounded properly	Verify system ground
	Noisy power source	Verify clean power supply power to main enclosure
Flow reported is not correct or inconsistent	Flow meter not calibrated	Calibrate flow meter, Calibrate Screen, page 106
	Flow meter is worn	Replace flow meter
	Material supply pressure is inconsistent	Fix supply system
No flow measurement	Flow meter pick-up sensor loose	Tighten flow meter pick-up sensor
	Flow too low	Verify flow rate is above minimum for the installed flow meter
	Loose wiring	Verify connection from flow meter to FCM
	Damaged flow meter pick-up sensor	Replace pick-up sensor
	Flow meter stuck, worn, damaged, or contaminated	Service flow meter

Dispense Valve

Problem	Cause	Solution
Valve not opening	Air not getting to the open port	Verify air pressure to solenoid
Valve not shutting off	Valve seal is worn and needs seal replacement	Verify air pressure to solenoid
		Verify solenoid operation
		Verify air line routing and connections
Sluggish open/close	Air pressure low	Verify air pressure is above 60 psi (410 kPa, 4.1 bar) Replace air filter
	Needle/seat worn	Rebuild valve; replace needle/seat
	Pressurized material past the valve shut-off is escaping	Reduce running pressure
		Reduce nozzle length
		Increase nozzle orifice size
	Faulty solenoid valve	Replace solenoid valve
Solenoid valve muffler restricted	Clean or replace muffler	
Material leaks from back of valve	Shaft seal worn, shaft is worn, or dirty valve	Rebuild valve; replace seals
Air leaks from dispense valve	Loose air connections	Check air connections; tighten if necessary
	Worn piston o-ring	Rebuild valve; replace piston o-ring

Recipe Troubleshooting

Problem	Cause	Solution
Fluid number has red background	Fluid is disabled or offline	If required, enable fluid
Order number = 99, red background	Order = 0; fluid in recipe mode	
	Order = 0; timer selected	
	Duplicate entry for selected fluid	

Gateway Module

Problem	Cause	Solution
No communication	Incorrect wiring	Check wiring per fieldbus standard. Refer to ProDispense Gateway LED status indicators and Appendix C - Communications Gateway Module, page 115 .
	Incorrect fieldbus settings	Confirm fieldbus settings at automation controller (fieldbus master) and ProDispense Gateway (fieldbus slave). Refer to Appendix A – Advanced Display Module (ADM) Operation, page 93 , for information on ProDispense Gateway configuration settings.
Incorrect data	Incorrect fieldbus configuration file installed on automation controller (fieldbus master)	Download ProDispense fieldbus configuration file from www.graco.com , and install on automation controller (fieldbus master).
	Incorrect map installed on ProDispense Gateway	Confirm correct ProDispense data map is installed on ProDispense Gateway. Refer to Appendix A – Advanced Display Module (ADM) Operation, page 93 for information on how to determine installed data map. If necessary, install a new Gateway data map.

LED Diagnostic Information

The following LED signals, diagnosis, and solutions apply to the Advanced Display Module, Fluid Control Module, and Gateway module.

Module Status LED Signal	Diagnosis	Solution
Green on	System is powered up	-
Yellow	Internal communication in progress	-
Red solid	Hardware failure	Replace module
Red flashing fast	Uploading software	-
Red flashing slow	Token error	Remove token and upload software token again.
Red flashes three times, pauses, then repeats	Invalid rotary switch position (FCM only)	Change rotary switch position to a valid position then restart the system. See FCM, page 14 .

Errors

Error codes are stored in the events log and are displayed on the event screen. Gateway error numbers are reported over the Gateway interface.

View Errors

When an error occurs, a flashing error pop-up is displayed that takes up the entire screen until the

error is acknowledged at the ADM by pressing . Errors can also be acknowledged over the gateway. Active errors are displayed in the menu bar.



Except for record errors, which only appear in the events log, all errors are displayed on the Events

screen. Previous errors can be viewed by navigating through the various event screens.

There are three levels of errors; alarms, deviations, and advisories. Alarms cause the system to shut down. Deviations and advisories do not shut down the system.

NOTE:

- Alarms set the fluid panel to standby.
- Advisories and deviations **do not** set the fluid panel to standby.
- Records are informational entries in the events log and do not modify system operation.

Codes and Troubleshooting

When a code is displayed on the lower portion of the screen, it has the 4-character code followed by a dash and another character. The character after the dash indicates the type of error.

- A: Alarm; will generate an audible alarm at the ADM and cause an attached light bar to modify its lighting.
- D: Deviation; will generate an audible alarm at the ADM and cause an attached light bar to modify its lighting.
- V: Advisory; only displayed in the menu bar.
- R: Record; only appears in the events log.

Refer to the table below for error information.

Errors

Code	Type	Text	Troubleshooting
System Nodes			
CAC0	ALARM	Communication Error FCM3 0	Inspect cables for damage on fluid panels 0&1 Software malfunction/replace software
CAC1	ALARM	Communication Error FCM3 1	Tighten CAN cable fittings for lost communications Software malfunction/replace software
CAC2	ALARM	Communication Error FCM3 2	
CAC3	ALARM	Communication Error FCM3 3	
CAGX	ALARM	Communication Error CGM	Check cable
CAG0	ALARM	Communication Error MB_TCP 0	Gateway specific error Check gateway cables Gateway Software or hardware malfunction
CAG1	ALARM	Communication Error MB_TCP 1	
CDC(0-3)	ALARM	Duplicate FCM3 (0-3)	Check rotary switch
CD0X	ALARM	Duplicate ADM	Check FCM rotary switches for duplicate settings
Fluid Panel			
WXC(1-8)	ALARM	Hardware Failure Fluid (1-8)	Power down/up module Check all cables Load latest software
WKC(1-8)	ALARM	Dispense Valve Failure Fluid (1-8)	Power down/up module Check solenoid cables Disconnect solenoid to identify if it is causing the alarm Replace FCM
WFC(1-8)	ALARM	Flow Meter Failure Fluid (1-8)	Power down/up module Check flow meter cables Disconnect flow meter to identify if it is causing the alarm
WHC(1-8)	ALARM	Regulator Failure Fluid 1	N/A
EJD(1-8)	DEVIATION	Timeout Dispense Fluid (1-8)	Increase fluid flow or increase dispense timeout Replace FCM
F8D(1-8)	ALARM	Flow Not Detected Fluid (1-8)	Check fluid flow from supply Check solenoid wires and functionality Confirm meter sensor functionality Clean or replace dirty or stuck meter
B9D(1-8)	DEVIATION	Volume Dispense Tolerance Fluid (1-8)	Reduce flow Increase dispense tolerance
B7D(1-8)	ALARM	Dispense Leak Detected Fluid (1-8)	Follow the dispense tolerance guidelines for flow rates and dispense size recommendations
B91(1-8)	RECORD	Volume Rollover Job Fluid (1-8)	Maximum totalizer volume exceeded
B9A(1-8)	RECORD	Volume Rollover Grand Fluid (1-8)	
USB			
EAUX	ADVISORY	USB Busy	System uploading/downloading files. Do not unplug USB drive.
EBUX	RECORD	USB Drive Removed	—
EQU1	RECORD	System Settings Downloaded	—
EQU2	RECORD	System Settings Uploaded	—
EQU3	RECORD	Custom Lang. Downloaded	—
EQU4	RECORD	Custom Language Uploaded	—
EQU5	RECORD	Logs Downloaded	—
EVUX	ADVISORY	USB Disabled	Enable USB download/upload in Advanced Settings to use USB port
WXUD	DEVIATION	USB Upload Error	Check/replace USB drive Verify content of upload files USB drive may not be compatible with system
WXUU	DEVIATION	USB Download Error	Check/replace USB drive USB drive may not be compatible with system

Code	Type	Text	Troubleshooting
EQU0	ADVISORY	USB Idle	Safe to remove USB drive
MMUX	ADVISORY	Maintenance USB Logs Full	ADM memory/storage full
WSUX	ADVISORY	USB Configuration Error	Check/replace USB drive Check upload files Re-install software
General			
WX00	ALARM	Software Errors	Cycle power to cause software reboot
CA0X	ALARM	Communication Error ADM	Check communication cables Power, but no communication with ADM
EB00	RECORD	Stop Button Pressed	Stop button on ADM was pressed
ES00	ALARM	Factory Defaults	System reset to factory defaults
EC00	RECORD	Setup Value Changed	System setup was changed
EM00	RECORD	Power Off	Main power supply was interrupted
EL00	RECORD	Power On	Main power supply was restored
Maintenance			
MED (1-8)	ADVISORY	Maintenance Valve Fluid (1-8)	Maintenance due – Check the valve – Perform required valve maintenance – Reset valve maintenance on the Maintenance screen
MFD (1-8)	ADVISORY	Maintenance Meter Flow Fluid (1-8)	Maintenance due – Check the flow meter – Perform required meter maintenance – Reset meter maintenance on the Maintenance screen
MGD (1-8)	ADVISORY	Maintenance Filter Fluid (1-8)	Maintenance due – Check filter – Clean/replace filter element – Reset filter maintenance on the Maintenance screen
Calibration			
END (1-8)	RECORD	Calibration Flow Meter Fluid (1-8)	Meter calibration complete
Dispense			
B9DX	ALARM	Volume Dispense Tolerance Job	Recipe dispense has been interrupted check recipe for failure point in dispense process.

Maintenance

Preventive Maintenance Schedule

The operating conditions of your particular system determine how often maintenance is required. Establish a preventive maintenance schedule by recording when and what kind of maintenance is needed, and then determine a regular schedule for checking your system.

The recommended maintenance procedures and frequencies to operate the equipment are shown below. The maintenance is divided between mechanical and electrical tasks. Maintenance must be performed by trained personnel per this schedule.

Task	Operator	Maintenance Person				
	Daily	Weekly	Monthly	3-6 months or 125,000 cycles	18-24 months or 500,000 cycles	36-48 months or 1,000,000 cycles
Mechanical						
Inspect system for leaks	✓					
Depressurize fluid, after operation	✓					
Inspect air filter bowls and drain		✓				
Check hoses for wear		✓				
Check/tighten fluid connections		✓				
Check/tighten air connections		✓				
Lubricate dispense valves*			✓			
Rebuild dispense valve*				✓		
Replace air filter					✓	
Replace Solenoid						✓
Electrical						
Check cables for wear		✓				
Verify cable connections		✓				

* Check component manual for more detailed maintenance information.

Flushing

Flush before changing fluids, before fluid can dry in the equipment, at the end of the day, before storing, and before repairing equipment. To perform this operation, see [Purging Fluid Lines, page 36](#).

Cleaning the ADM

Use any alcohol-based household cleaner, such as glass cleaner, to clean the ADM.

Software Installation and Update

Update ADM, FCMs, and CGM

Back up the system configuration and custom language file (if installed) before updating software. See [USB Data, page 41](#) for more information.

NOTE: This procedure will update the software version on the ADM, followed by update of recognized FCMs and CGM (if installed). This update is performed over the CAN connections with those devices. If a new or replacement FCM is installed in the system, it will require separate software installation using the token that was provided with it.

1. At the control panel, turn off power to the system.
2. Remove the token access panel.

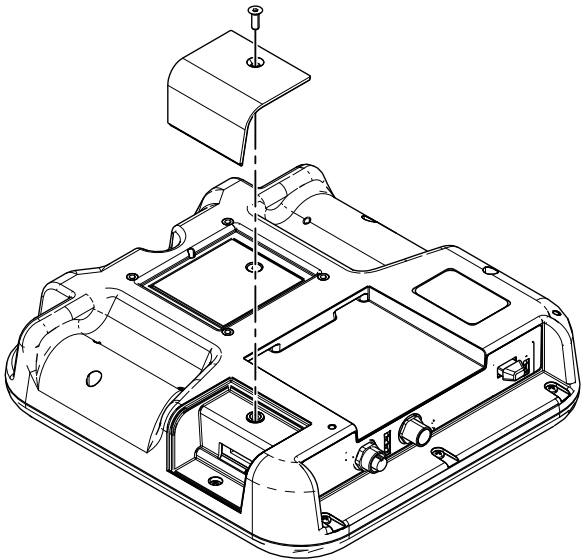

ti21699a

3. Insert and press software token firmly into slot.
NOTE: There is no preferred orientation of token.

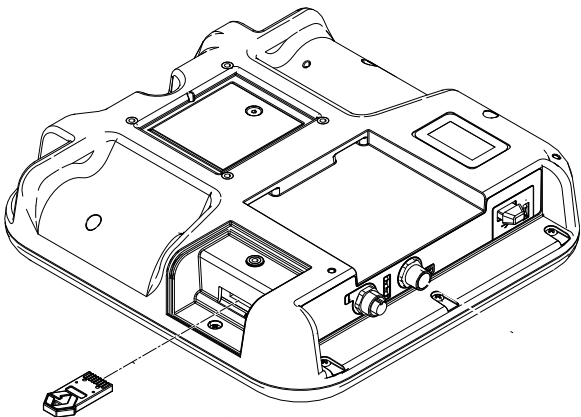

4. Turn on power to the system. The red indicator light next to the USB port will flash until new software is completely loaded.
5. After the red indicator light shuts off, turn off power to the system.
6. Remove software token.
7. Replace token access panel.

Load FCM Software

NOTE: The FCM connection is temporarily disabled during the use of the software token.

Except for the control panel FCM, which has software loaded at the factory, this procedure must be performed at each FCM installed in the system at the time they are first placed into use. If any FCM has not had the operation software installed or if it differs in version from the ADM, it will not function during system operation.

NOTE: Ensure that the FCM CAN cable is attached to the system. Without connection, the FCM will have no power.

1. Turn off power to the system.
2. Remove access cover.

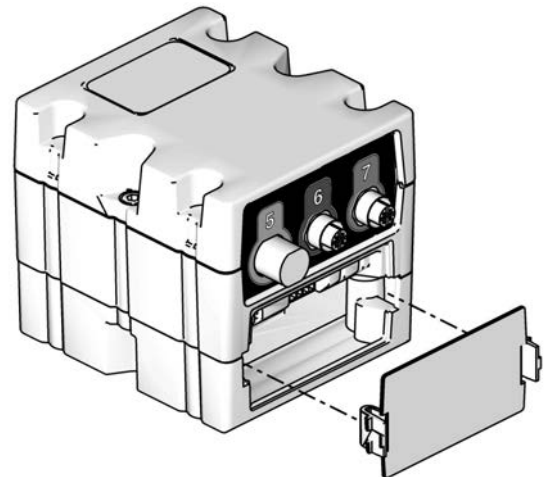

Maintenance

3. Insert and press software token firmly into slot.
NOTE: There is no preferred orientation of token.

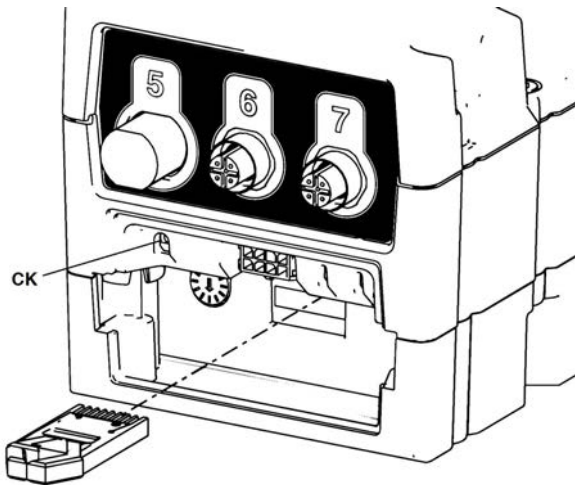

4. Turn on power to the system. The red indicator light (CK) will flash until new software is completely loaded.
5. After the red indicator light shuts off, turn off power to the system.
6. Remove software token.
7. Replace access cover.

NOTE: Loading the software on the token may install a more recent version than is currently installed in the system. If this is the case, use the software update using the ADM to update all other system components to this newer version software. Refer to [Update ADM, FCMs, and CGM, page 51](#).

Upgrade CGM

Upgrading a CGM involves two updates. First, update the software from the ADM and then update the Fieldbus Map.

Update Fieldbus Map

NOTE: The fieldbus connection is temporarily disabled during the use of a map token. The following instructions apply to all Gateway modules.

1. Perform the software update before performing this procedure. See [Update ADM, FCMs, and CGM, page 51](#).

2. Remove the access cover.

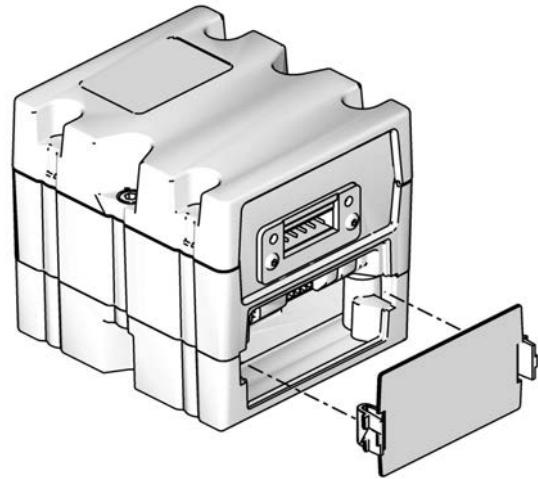

3. Insert and press map token firmly into slot. This is a different token than the one containing the software update.
NOTE: There is no preferred orientation of token.
4. Press and hold the push button (CB) for three seconds and then release. The red indicator light (CK) will flash twice, pause, and then once after the data map is uploaded.

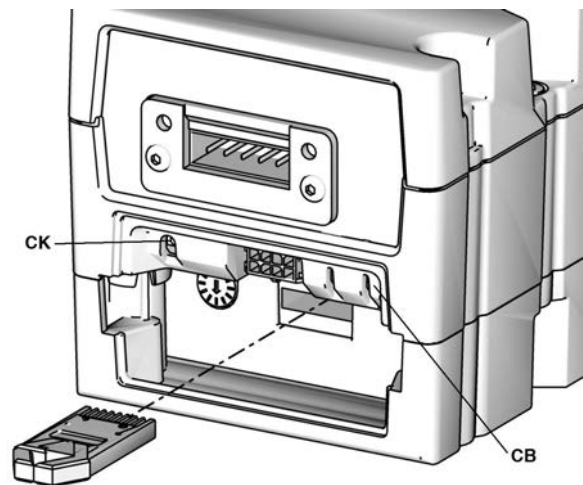

5. Remove map token when software has successfully uploaded.
6. Replace access cover.

Repair

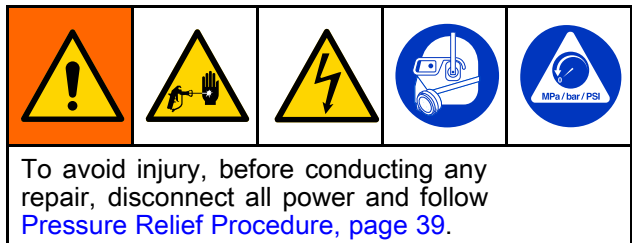

Replace ADM

If ADM functionality allows, prior to replacing the ADM, Graco recommends downloading the configuration and system settings for upload into the new ADM. See [USB Download Procedure, page 42](#).

1. If ADM functionality allows, perform [Shutdown, page 39](#).
2. Turn off the control panel power switch.
3. Disconnect all cables attached to the ADM.
4. Remove the ADM from the mounting bracket.
5. If not already installed in new ADM, install the battery.
6. Connect cables removed in step 3 to the new ADM.
7. Turn on the control panel power switch.
8. Upload all system configuration and system settings into the new ADM. See [USB Upload Procedure, page 43](#).
9. Navigate to the Advanced Screen 4 and observe the software version for the ADM matches all other installed modules. If the ADM has a newer version software, all other modules will need to be updated to the same version as the ADM. See [Update ADM, FCMs, and CGM, page 51](#) to bring all modules to the same version.
10. If desired, return the ADM to the mounting bracket.

Replace Control Panel Power Supply

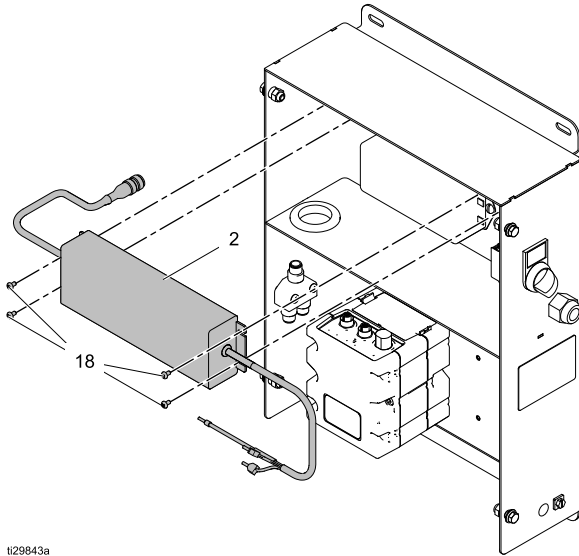

t29843a

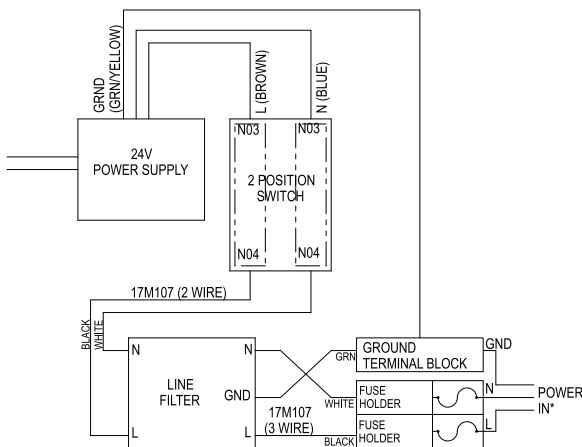

1. Turn off the control panel power switch and disconnect the input power to the switch by disconnecting from the power source or turn off the circuit breaker for this system.
NOTE: To enable removing the cover without needing to remove things attached to it, the cover can be moved so that the 2 mounting slots on the right side of the cover attach to the 2 mounting screws on the left side of the control panel assembly.
2. Loosen the 4 cover attachment screws and remove the cover.
NOTE: Remove wire ties as necessary from tie-down points.
3. Disconnect the power supply output cable from the CAN splitter.
4. Disconnect the power supply wires from the ground bus and power switch.
5. Remove the 4 screws (18) and remove the power supply from the control panel assembly.
6. Install the new power supply by performing steps 1 - 5 in reverse order.
NOTE: Wire zip ties must be supplied by customer.
7. Restore input power to the control panel assembly.

Replace Control Panel FCM

This procedure will require shutting down the entire system. Ensure all processes have been placed into a condition that will allow the shutdown without affecting a dispense activity.

This procedure will work for any FCM installed in the control panel.

NOTE: If you have 2 fluid panels attached to this FCM, ensure that you mark the 4 cables attached to connectors 1–4 for easy identification during the connection to the new FCM.

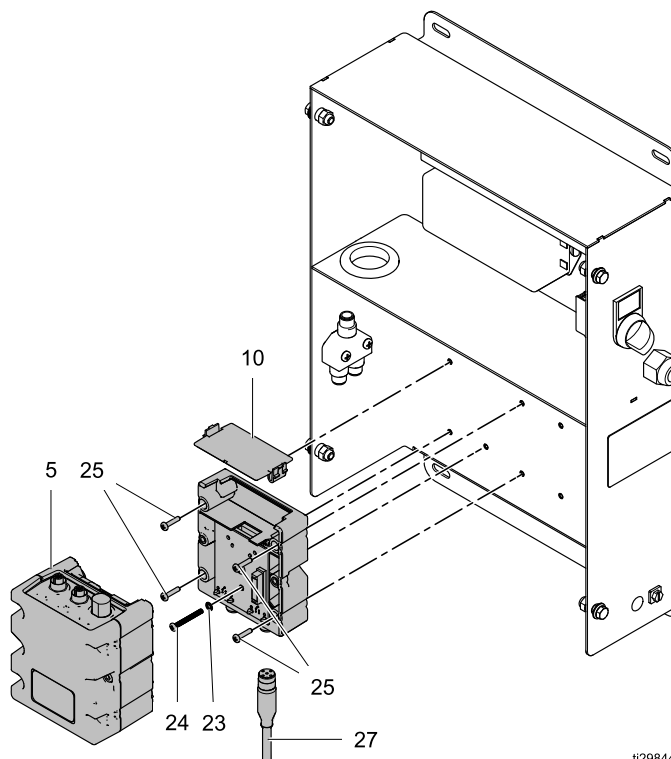

1. Turn off the control panel power switch.
2. Disconnect all cables from the bottom of the ADM.
3. Loosen the 4 control panel front cover screws. Remove the cover and set aside.
4. Remove all cables attached to the FCM.

NOTE: If a termination resistor is attached to a CAN connection on the FCM, remove it and retain for installation on the new FCM.
5. Remove the two screws half way up each side of the FCM and unplug the center section from the FCM base.
6. Loosen the ground screw (24) so that it isn't contacting the back of the control panel
7. Remove the 4 base mounting screws and remove the FCM base.
8. Set the new FCM rotary switch to the same setting as the FCM being removed.
9. Perform the removal steps in reverse order to install the replacement.

Replace Fluid Panel FCM

This procedure will require shutting down the entire system. Ensure all processes have been placed into a condition that will allow the shutdown without affecting a dispense activity.

This procedure will work for any FCM installed in a fluid panel.

NOTE: If you have 2 fluid panels attached to this FCM, ensure that you mark the 4 cables attached to connectors 1–4 for easy identification during the connection to the new FCM.

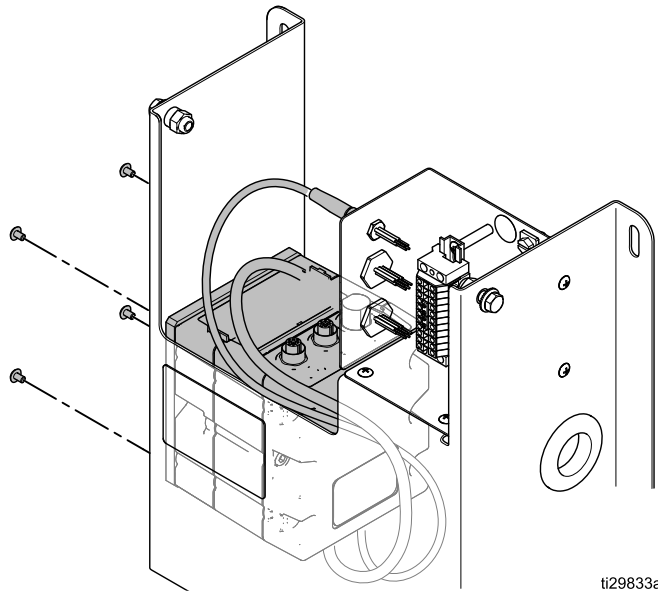

NOTE: Prior to beginning this operation, prepare the replacement by mounting it on the provided mounting plate.

1. Turn off the control panel power switch.
2. Remove all cables attached to the FCM.

NOTE: If a termination resistor is attached to a CAN connection on the FCM, remove it and retain for installation on the new FCM.

3. Remove the 4 screws attaching the FCM mounting plate to the fluid panel.

4. Set the new FCM rotary switch to the same setting as the FCM being removed.

NOTE: The new FCM must have software installed prior to use. If necessary, connect CAN cables from the FCM being replaced and power up the system long enough to load software in the FCM. For instruction on loading the FCM software, see [Load FCM Software, page 51](#). After the FCM software has been installed, power down the system and complete this procedure.

5. Perform the removal steps in reverse order to install the replacement.

Replace Fluid Panel Junction Box

NOTE: Replacing the junction box from a single fluid panel will require shutting down the entire system. Before performing this repair, ensure that all other processes have been completed or can be shut down.

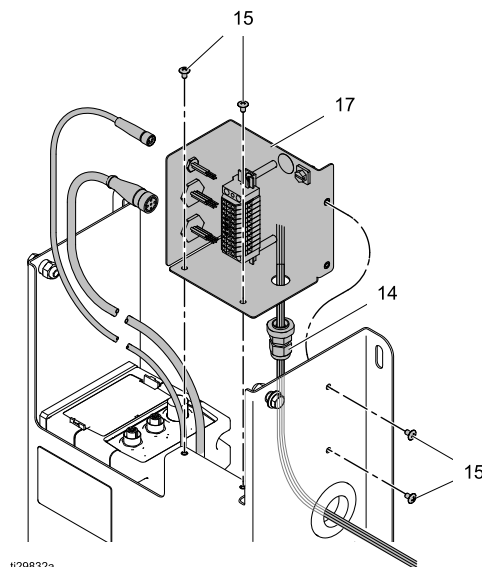

NOTE: Remote Operator Station cable not shown. If present, it is attached to connector A of the Junction Box.

1. Turn off the control panel power switch.
2. Disconnect all cable connectors from the left side of the junction box (17). There will be 2 or 3 cables present, depending on whether a remote operator station is present for this fluid panel.
3. Remove the 4 screws (15) which attach the junction box to the fluid panel. Retain screws for re-use.
NOTE: The meter and solenoid wires enter the junction box through the strain relief (14) at the bottom right of the junction box. Verify that the existing junction box terminal wiring is documented before removing wires from terminal strip.
4. Remove the meter and solenoid wires from the terminal strip.
NOTE: Your meter may have resistors or diodes attached to the meter wiring at the terminal strip. Ensure that these components are not damaged during the replacement process.
5. Loosen strain relief and remove meter and solenoid wires.
6. Loosen the strain relief on the new junction box and insert the meter and solenoid wires.
7. Connect the meter and solenoid wires to the appropriate terminal block connections. Refer to the schematics and any notes made prior to wire disconnection in step 4. Do not overtighten terminal block screws.
8. Position meter and solenoid wires within the strain relief so that strain is not present and tighten the strain relief to hold the wires in position. Do not overtighten the strain relief.
9. Position the junction box and attach to the fluid panel using the four screws (15).
10. Reconnect the 2 (or 3) cables to the left side of the junction box.

Schematics of meter and solenoid wiring for fluid panels.

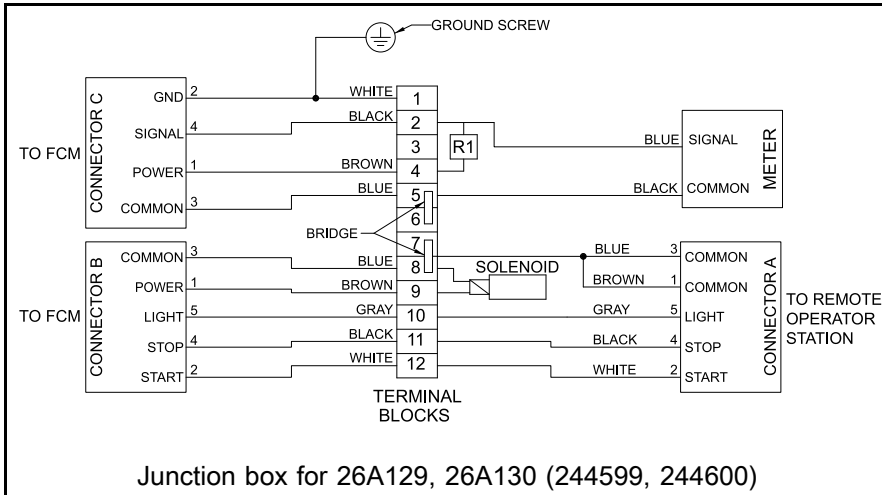

Junction box 244660 is mounted on the outside of fluid panels 244599, 244600, 244601, 246837, 244838, and 246839. These fluid panels were used with controller 244561.

Upgrading fluid panel junction box 244660 on each desired fluid panel with junction box upgrade kit 26A243 will allow that fluid panel to be connected to controller 26A070 via an FCM. **NOTE:** Before connecting any of these older panels to the 26A070 control panel, review the power usage currently consumed by the current configuration. The relationship between the old fluid panels and the new fluid panels can be seen in the schematics. Use the values for the new fluid panels to determine the approximate values which will apply in calculating power consumption for the older panels. See [Appendix B - System Design, page 114.](#)

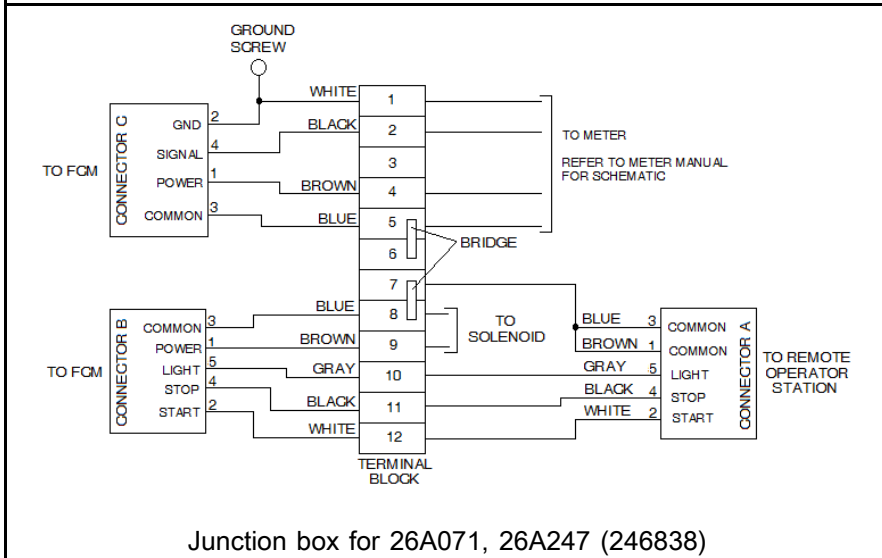
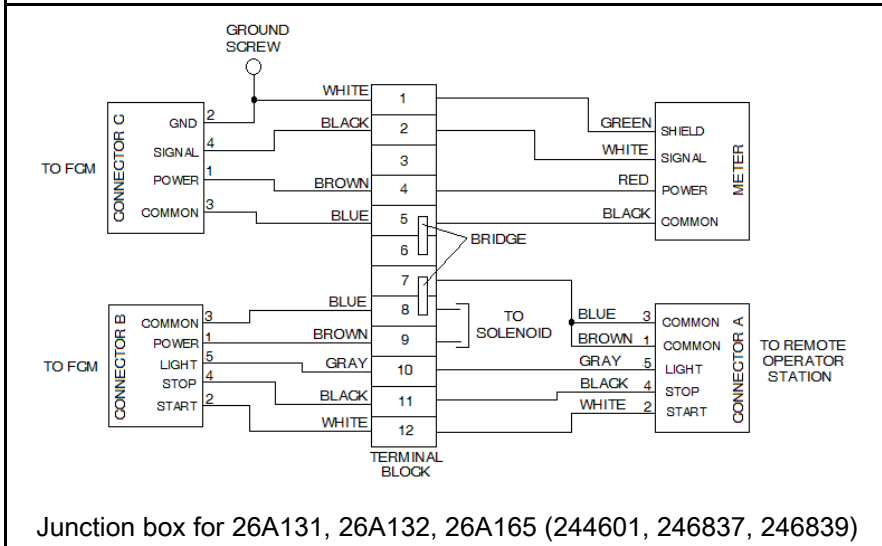

Servicing Fluid Panel 26A129

NOTE: Servicing the fluid panel will require shutting down the entire system. Before performing this repair, ensure that all other processes have been completed or can be shut down.

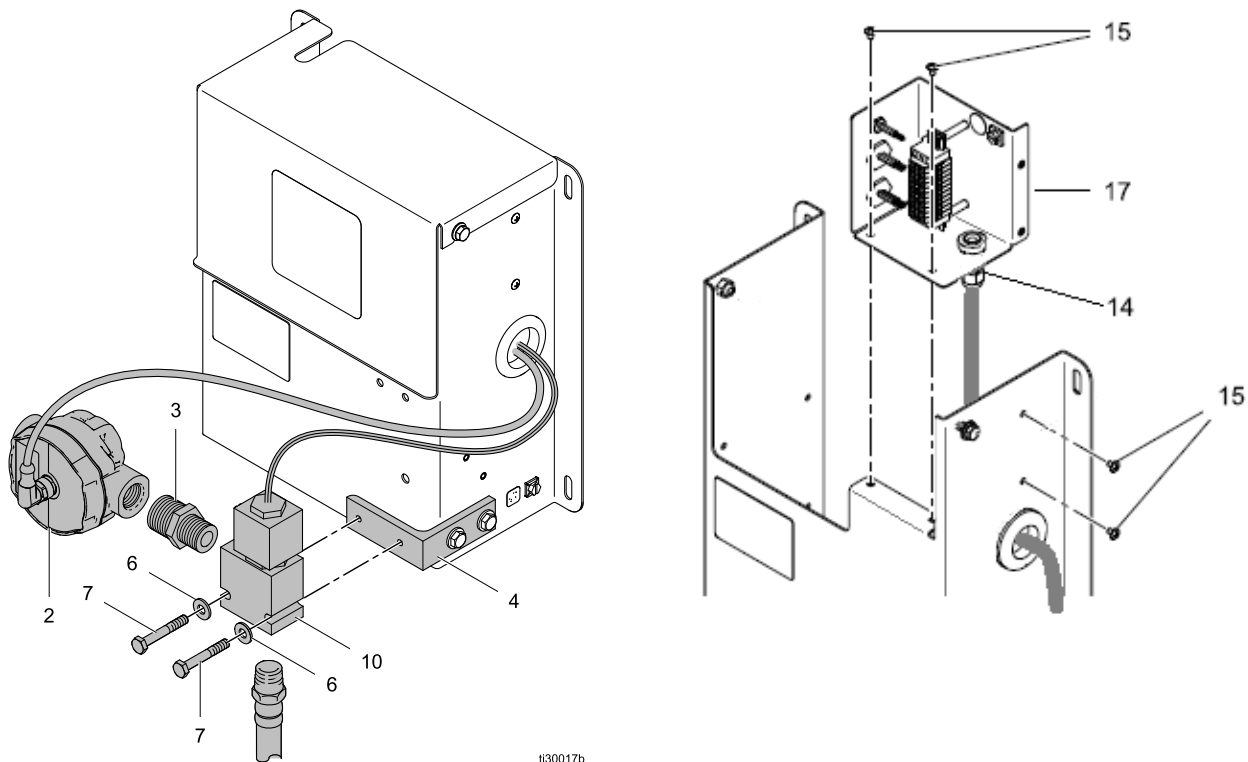

Fluid panel 26A129 junction box schematic:

NOTE: The schematic below also represents how to wire the solenoid and meter into the 26A243 junction box upgrade on a 244599 fluid panel.

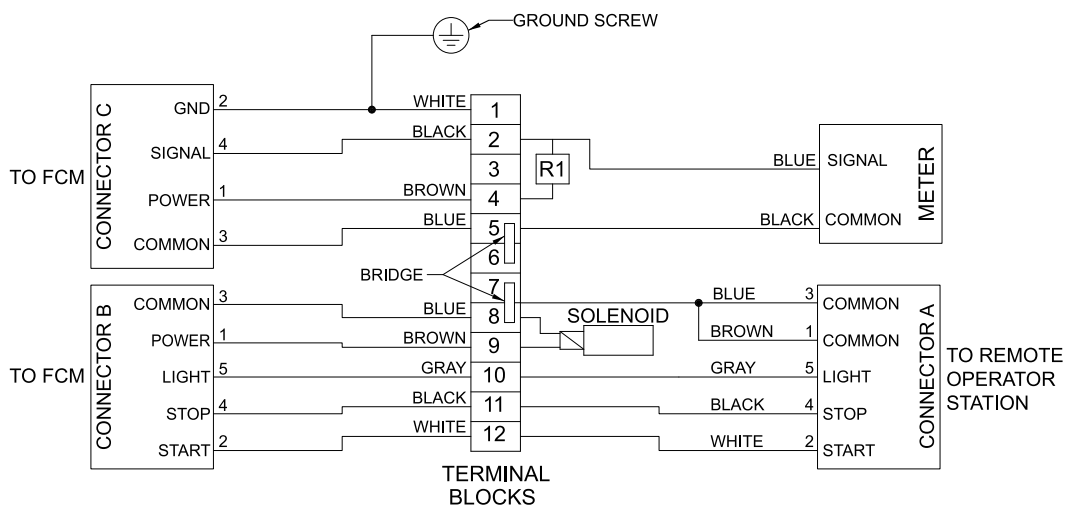

Repair

1. Purge the supply line. See [Purging Fluid Lines, page 36](#).
2. Perform [Pressure Relief Procedure, page 39](#).
3. Turn off control panel power switch.
4. Remove the fluid panel top cover.
5. At the junction box, disconnect the meter leads and if the solenoid is being replaced, disconnect the solenoid leads.
NOTE: Loosening the strain relief (14) may require removing screws (15) so that the junction box can be moved.
6. Loosen the strain relief and remove the wiring for the meter from the fluid panel. If the solenoid is being replaced, remove the solenoid wiring from the strain relief and fluid panel.
7. Disconnect the fluid supply line fitting on the inlet (left side) of the meter.
8. **If replacing the meter (2):**
 - a. Disconnect the meter from the fitting on the outlet side of the meter.
NOTE: Apply thread tape to fitting threads.
 - b. Attach the replacement meter to the solenoid valve fitting.
 - c. Attach the fluid supply line to the meter inlet.
 - d. Proceed to step 10.
9. **If replacing the solenoid valve (10):**
 - a. Disconnect the fluid line at the bottom of the solenoid valve.
 - b. Loosen screws (7). Remove one of the screws. Remove the solenoid valve and meter.
 - c. In a vice, gently clamp the solenoid valve. Remove the fitting from the inlet to the solenoid valve.
NOTE: Wrap thread tape on the fluid line fittings on the solenoid valve.
 - d. Place the new solenoid valve in the vice and install the fluid line fitting on the meter into the solenoid valve.
 - e. Install the solenoid valve on the fluid panel mounting bracket using screws (7) and washers (6).
 - f. Attach the meter fluid supply line fitting to the meter inlet.
 - g. Attach the fluid line fitting to the bottom of the solenoid valve.
10. Route all removed wiring through the access hole on the side of the fluid panel and the junction box strain relief (14).
11. Refer to the schematic for the fluid panel junction box and attach all meter and solenoid wiring.
12. Position all wires passing through the junction box strain relief so that the terminal block connections are not under strain and tighten the strain relief. Do not overtighten.
13. If necessary, reattach the junction box to the fluid panel.
14. Attach the fluid panel top cover.
15. At the control panel, turn on the power.
16. Under low pressure, load the fluid line and monitor for leaks at all fittings on the fluid panel. Tighten fittings as needed. If necessary, refer to [Loading Fluid Lines, page 36](#).
17. If necessary, calibrate the fluid panel.

Servicing Fluid Panel 26A130

NOTE: Servicing the fluid panel will require shutting down the entire system. Before performing this repair, ensure that all other processes have been completed or can be shut down.

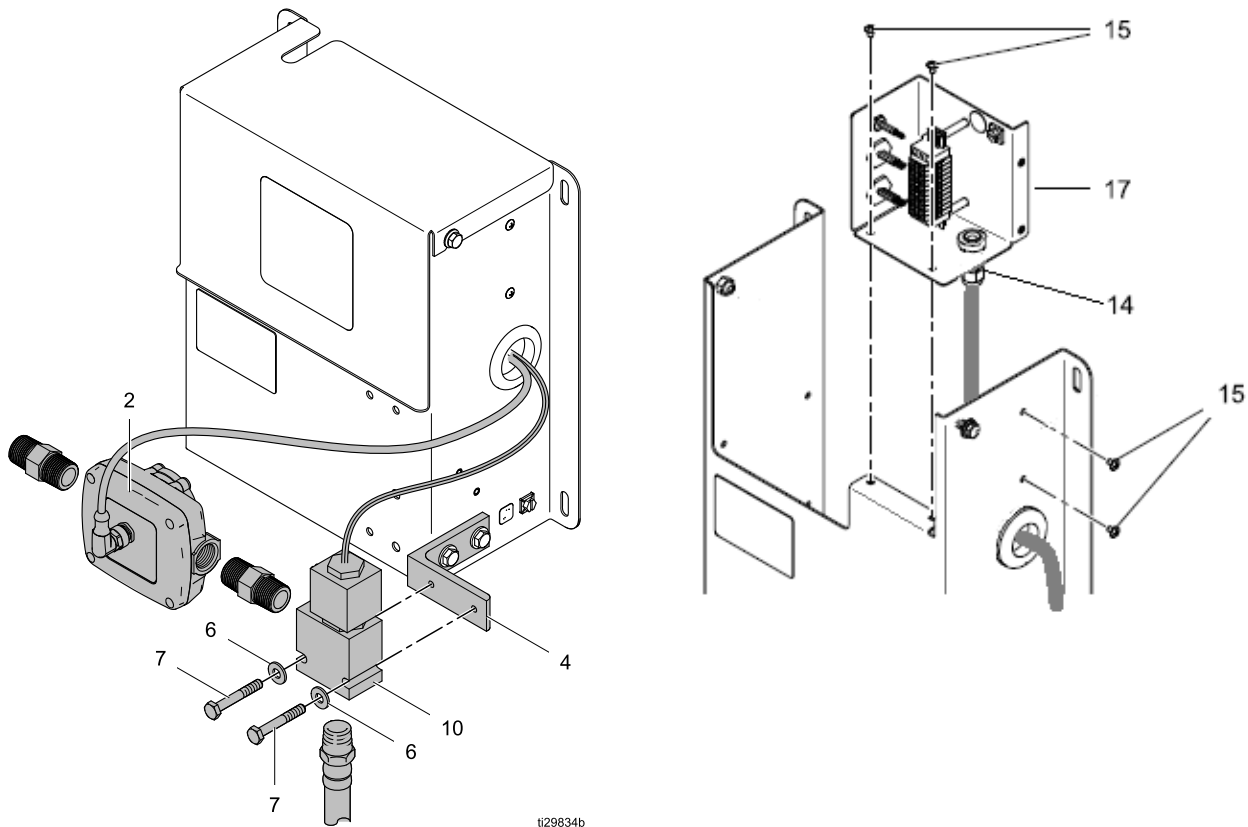

Fluid panel 26A130 junction box schematic:

NOTE: The schematic below also represents how to wire the solenoid and meter into the 26A243 junction box upgrade on a 244600 fluid panel.

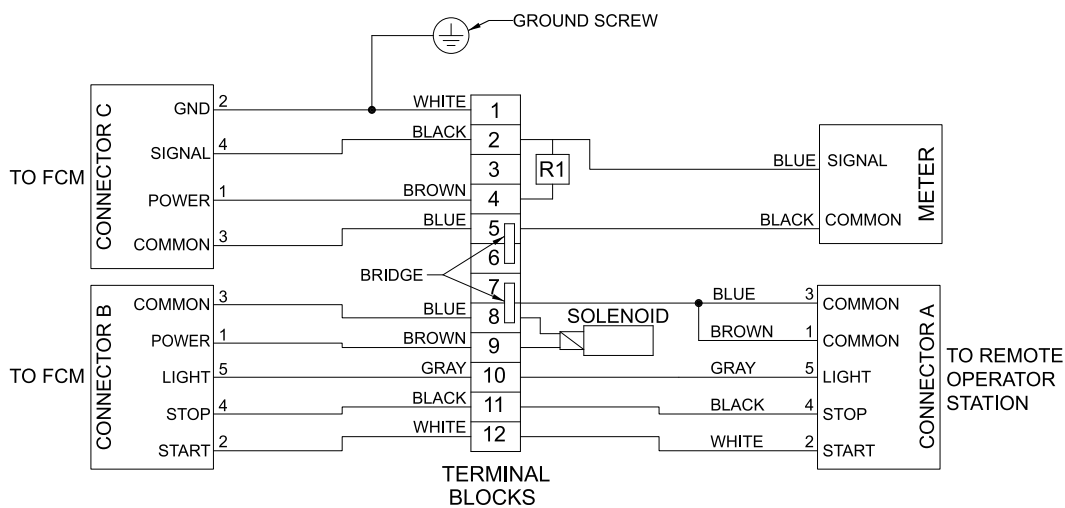

Repair

1. Purge the supply line. See [Purging Fluid Lines, page 36](#).
2. Perform [Pressure Relief Procedure, page 39](#).
3. Turn off control panel power switch.
4. Remove the fluid panel top cover.
5. At the junction box, disconnect the meter leads and if the solenoid is being replaced, disconnect the solenoid leads.
NOTE: Loosening the strain relief (14) may require removing screws (15) so that the junction box can be moved.
NOTE: The diode and resistors attached to the meter leads must be handled carefully to prevent damage while passing through the strain relief.
6. Loosen the strain relief and remove the wiring for the meter from the fluid panel. If the solenoid is being replaced, remove the solenoid wiring from the strain relief and fluid panel.
7. **If replacing the meter (2):**
 - a. Disconnect the fluid supply line fitting on the inlet (left side) of the meter.
 - b. Disconnect the fitting on the outlet side of the meter.
 - c. On the replacement meter, disconnect the fittings on both sides.
NOTE: The fluid inlet side of the meter contains a screen which can be cleaned. When installing the meter, observe the flow direction arrows on the meter body.
 - d. Connect the meter to both fittings from steps a and b above.
 - e. Proceed to step 9.
8. **If replacing the solenoid valve (10):**
 - a. Disconnect the fluid line at the bottom of the solenoid valve.
 - b. Disconnect the fitting on the outlet side of the meter and set the meter aside.
 - c. Loosen screws (7). Remove one of the screws. Remove the solenoid valve.
 - d. In a vice, gently clamp the solenoid valve. Disconnect the fluid line from the solenoid valve.
NOTE: Wrap thread tape on the fluid line fittings on the solenoid valve.
 - e. Place the new solenoid valve in the vice and install the fluid line into the solenoid valve.
 - f. Install the solenoid valve on the fluid panel mounting bracket using screws (7) and washers (6).
 - g. Attach the meter outlet fitting to the solenoid valve.
 - h. Attach the fluid line fitting to the bottom of the solenoid valve.
9. Route all removed wiring through the access hole on the side of the fluid panel and the junction box strain relief (14).
10. Refer to the schematic for the fluid panel junction box and attach all meter and solenoid wiring.
11. Position all wires passing through the junction box strain relief so that the terminal block connections are not under strain and tighten the strain relief. Do not overtighten.
12. If necessary, reattach the junction box to the fluid panel.
13. Attach the fluid panel top cover.
14. At the control panel, turn on the power.
15. Under low pressure, load the fluid line and monitor for leaks at all fittings on the fluid panel. Tighten fittings as needed. If necessary, refer to [Loading Fluid Lines, page 36](#).
16. If necessary, calibrate the fluid panel.

Servicing Fluid Panel 26A131 or 26A165

NOTE: Servicing the fluid panel will require shutting down the entire system. Before performing this repair, ensure that all other processes have been completed or can be shut down.

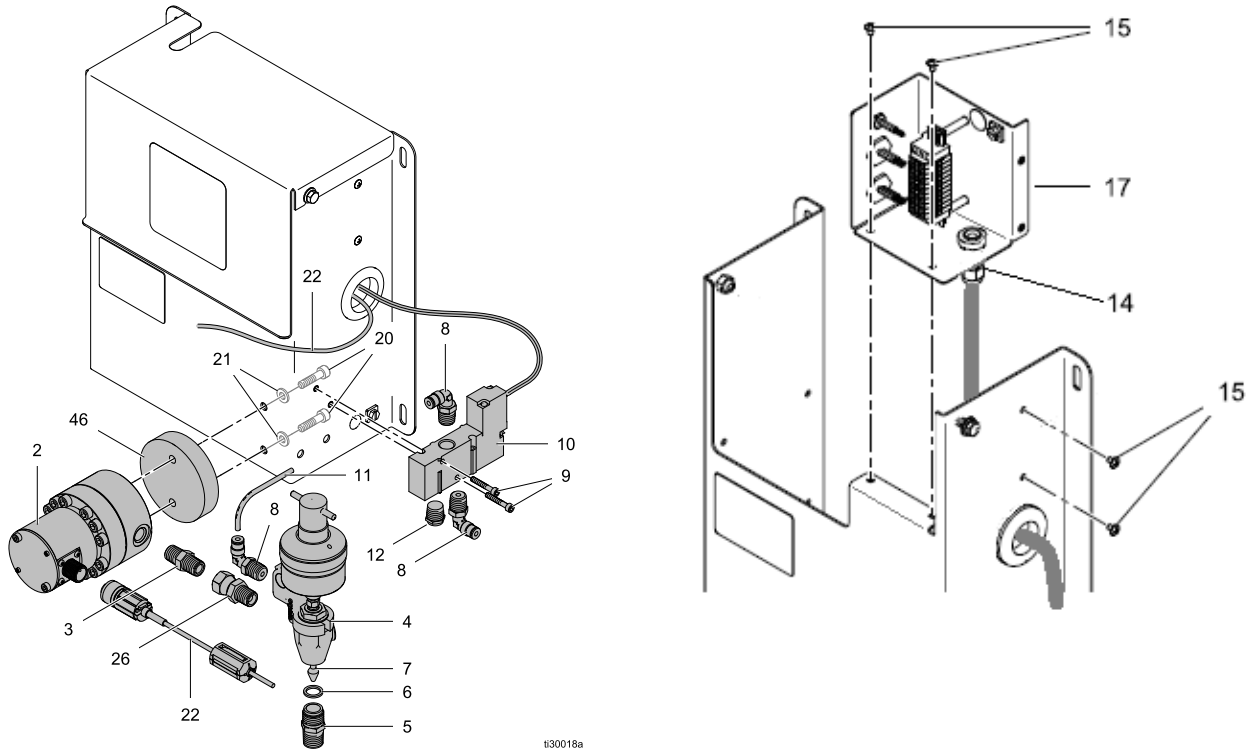

Fluid panel 26A131 shown

Fluid panel junction box schematic:

NOTE: The schematic below also represents how to wire the solenoid and meter into the 26A243 junction box upgrade on a 244601 or 246837 fluid panel.

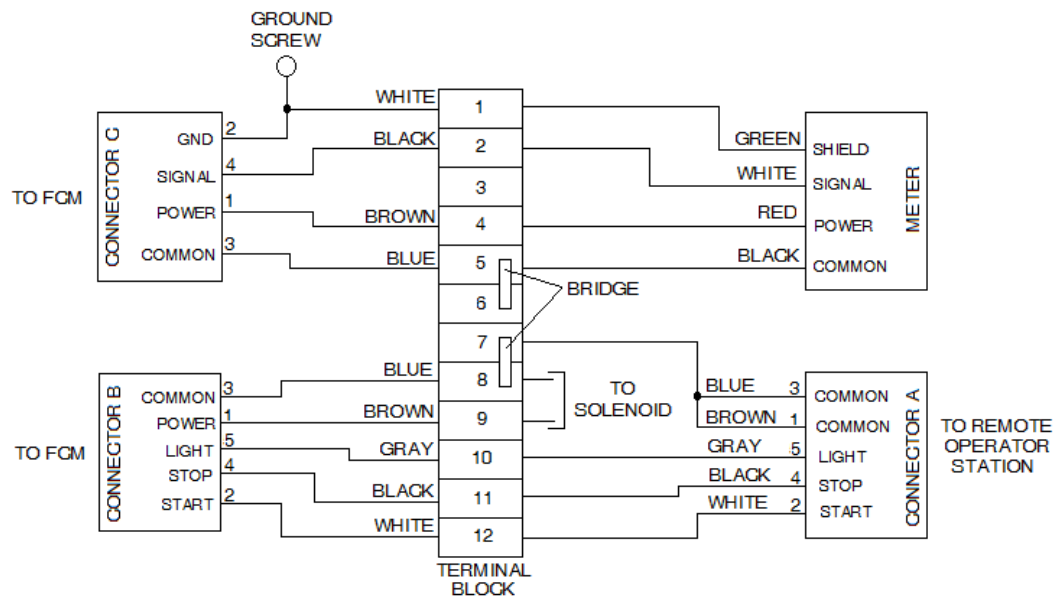

Repair

1. Purge the supply line. See [Purging Fluid Lines, page 36](#).
2. Perform [Pressure Relief Procedure, page 39](#).
3. Turn off control panel power switch.
4. Remove the fluid panel top cover.
5. At the junction box, if the meter or dispense valve are being replaced, disconnect the meter leads and if the solenoid is being replaced, disconnect the solenoid leads.
NOTE: Loosening the strain relief (14) may require removing screws (15) so that the junction box can be moved.
6. Loosen the strain relief and remove the wiring for the meter from the fluid panel. If the solenoid is being replaced, remove the solenoid wiring from the strain relief and fluid panel.
NOTE: Remove fittings from old components and reinstall in new components as needed.
7. **If replacing the meter (2):**
 - a. Disconnect the fluid supply line fitting on the inlet (left side) of the meter.
 - b. Disconnect the air line from the solenoid air valve to the dispense valve.
 - c. If necessary, disconnect the fluid supply line on the outlet of the dispense valve.
 - d. Remove screws (20) and washers (21) and remove the meter and dispense valve assembly.
 - e. Place a wrench on the fitting (5) and disconnect the meter.
NOTE: Observe any flow direction arrow on the meter when installing. Use thread tape on supply line fittings.
 - f. Perform steps a-e above in reverse order to install the meter.
 - g. Proceed to step 10.
8. **If replacing the dispense valve:**
 - a. Perform steps 7.a - 7.d.
 - b. Place a wrench on the fitting (26) and disconnect the dispense valve.
NOTE: Use thread tape on supply line fittings.
 - c. Attach fitting (26) to the dispense valve.
 - d. Perform steps 7.a. - 7.d. in reverse order to install the meter and dispense valve.
 - e. Proceed to step 10.
9. **If replacing the solenoid and air valve (10):**
 - a. Shut off and bleed the air supply to the solenoid air valve.
 - b. Disconnect the inlet and outlet air lines at the solenoid air valve.
 - c. Remove screws (9) and remove the solenoid air valve.
 - d. Using screws (9), install the new solenoid air valve.
 - e. Attach the air lines to the solenoid air valve.
10. Route all removed wiring through the access hole on the side of the fluid panel and the junction box strain relief (14).
11. Refer to the schematic for the fluid panel junction box and attach all meter and solenoid wiring.
12. Position all wires passing through the junction box strain relief so that the terminal block connections are not under strain and tighten the strain relief. Do not overtighten.
13. If necessary, reattach the junction box to the fluid panel.
14. Attach the fluid panel top cover.
15. At the control panel, turn on the power.
16. Pressurize the air supply line and check for leaks.
17. If the fluid supply line was disconnected, under low pressure, load the fluid line and monitor for leaks at all fittings on the fluid panel. Tighten fittings as needed. If necessary, refer to [Loading Fluid Lines, page 36](#).
18. If necessary, calibrate the fluid panel.

Servicing Fluid Panel 26A132

NOTE: Servicing the fluid panel will require shutting down the entire system. Before performing this repair, ensure that all other processes have been completed or can be shut down.

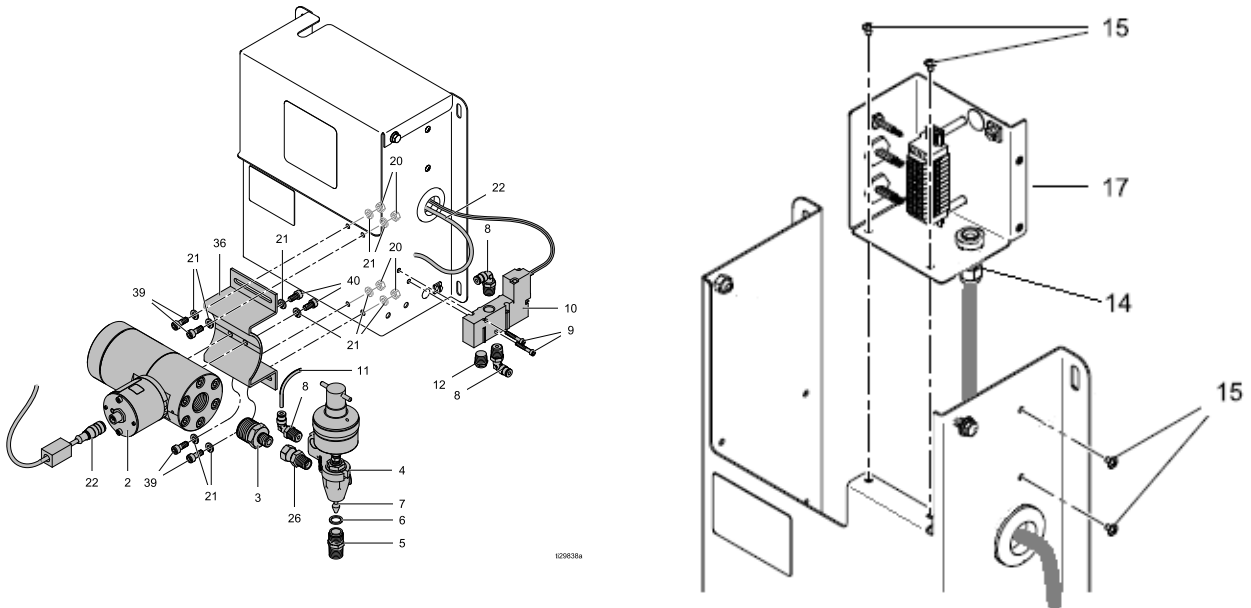

Fluid panel 26A132 junction box schematic:

NOTE: The schematic below also represents how to wire the solenoid and meter into the 26A243 junction box upgrade on a 246839 fluid panel.

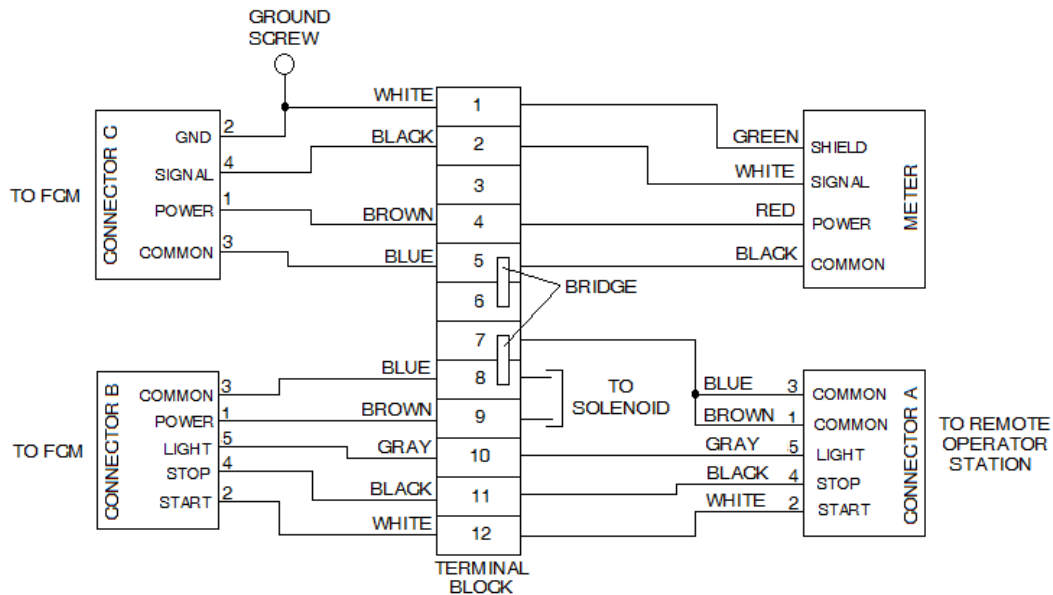

Repair

1. Purge the supply line. See [Purging Fluid Lines, page 36](#).
2. If necessary, perform [Pressure Relief Procedure, page 39](#).
3. Turn off control panel power switch.
NOTE: If not replacing the solenoid air valve, skip steps 4 - 6.
4. Remove the fluid panel top cover.
5. At the junction box, if the solenoid is being replaced, disconnect the solenoid leads.
NOTE: Loosening the strain relief (14) may require removing screws (15) so that the junction box can be moved.
6. Loosen the strain relief and remove the wiring for the meter from the fluid panel. If the solenoid is being replaced, remove the solenoid wiring from the strain relief and fluid panel.
NOTE: Remove fittings from old components and reinstall in new components as needed.
7. **If replacing the meter (2):**
 - a. At the meter, disconnect the meter cable.
 - b. Disconnect the fluid supply line fitting on the inlet (left side) of the meter.
 - c. Disconnect the air line from the solenoid air valve to the dispense valve.
 - d. If necessary, disconnect the fluid supply line on the outlet of the dispense valve.
 - e. Remove screws, washers, and nuts (20, 21, 37) and remove the meter, meter bracket, and dispense valve assembly.
 - f. Move the meter bracket to the new meter.
 - g. Place a wrench on the fitting (3) and disconnect the meter.
NOTE: Use thread tape on supply line fittings.
 - h. Perform steps a-e above in reverse order to install the meter.
 - i. Proceed to step 10.
8. **If replacing the dispense valve:**
 - a. Disconnect the air line from the solenoid air valve to the dispense valve.
 - b. Disconnect the fluid supply line on the outlet of the dispense valve.
NOTE: If additional room is needed to allow disconnecting the dispense valve from the meter fitting, the meter mounting bracket can be loosened and slid to the right.
 - c. Place a wrench on the fitting (26) and disconnect the dispense valve.
NOTE: Use thread tape on supply line fittings.
 - d. Attach the dispense valve to fitting (26).
 - e. If the meter mounting bracket was moved, place in the desired location and tighten the screws.
 - f. Attach the air line from the solenoid air valve to the dispense valve.
 - g. Attach the fluid supply line to the outlet of the dispense valve.
 - h. Proceed to step 10.
9. **If replacing the solenoid and air valve (10):**
 - a. Shut off and bleed the air supply to the solenoid air valve.
 - b. Disconnect the inlet and outlet air lines at the solenoid air valve.
 - c. Remove screws (9) and remove the solenoid air valve.
 - d. Using screws (9), install the new solenoid air valve.
 - e. Attach the air lines to the solenoid air valve.
 - f. Route all removed wiring through the access hole on the side of the fluid panel and the junction box strain relief (14).
 - g. Refer to the schematic for the fluid panel junction box and attach the solenoid wiring.
 - h. Position all wires passing through the junction box strain relief so that the terminal block connections are not under strain and tighten the strain relief. Do not overtighten.
 - i. If necessary, reattach the junction box to the fluid panel.
 - j. Attach the fluid panel top cover.
10. At the control panel, turn on the power.
11. Pressurize the air supply line and check for leaks.
12. If the fluid supply line was disconnected, under low pressure, load the fluid line and monitor for leaks at all fittings on the fluid panel. Tighten fittings as needed. If necessary, refer to [Loading Fluid Lines, page 36](#).
13. If necessary, calibrate the fluid panel.

Servicing Fluid Panel 26A071 and 26A247

NOTE: Servicing the fluid panel will require shutting down the entire system. Before performing this repair, ensure that all other processes have been completed or can be shut down.

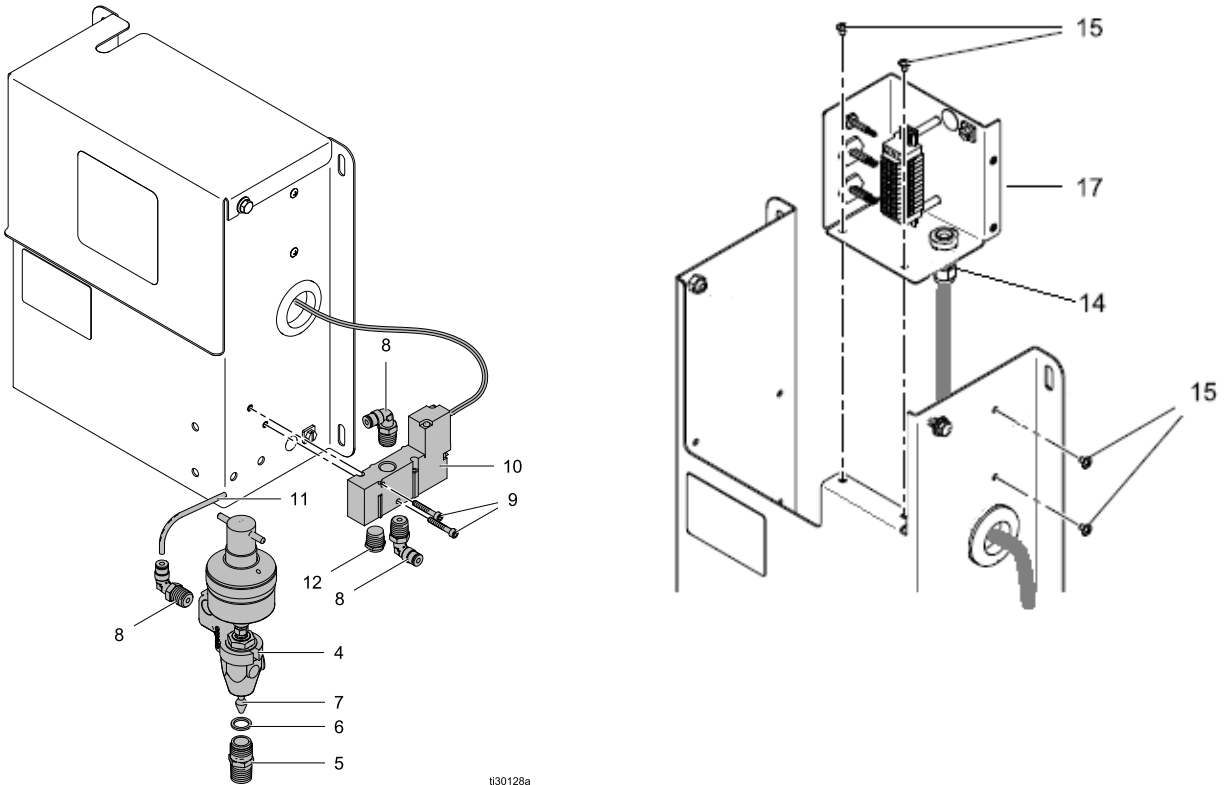

030128a

Fluid panel 26A071 shown

Fluid panel 26A071 and 26A247 junction box schematic:

NOTE: The schematic below also represents how to wire the solenoid and meter into the 26A243 junction box upgrade on a 246838 fluid panel.

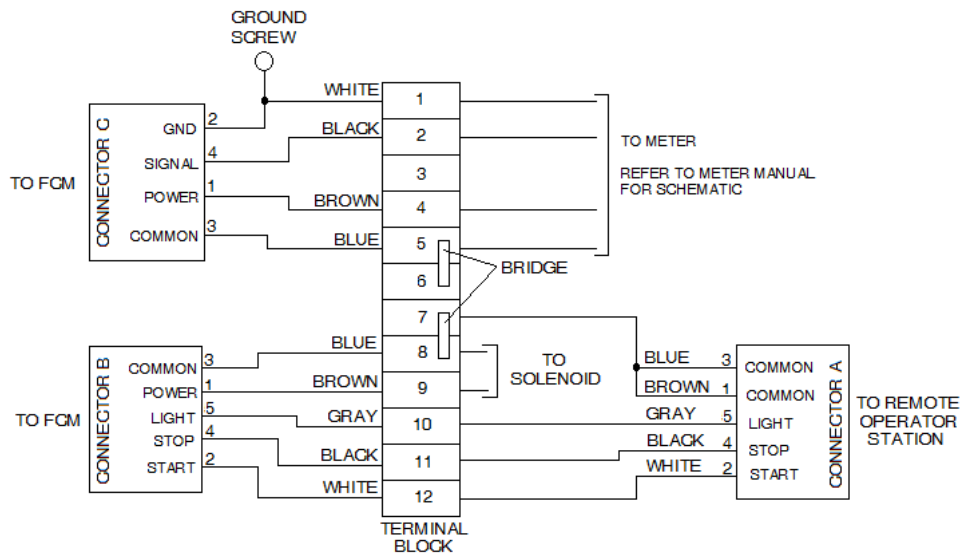

Repair

1. Purge the supply line. See [Purging Fluid Lines, page 36](#).
2. Perform [Pressure Relief Procedure, page 39](#).
3. Turn off control panel power switch.
4. Remove the fluid panel top cover.
5. At the junction box, if the meter or dispense valve are being replaced, disconnect the meter leads and if the solenoid is being replaced, disconnect the solenoid leads.
NOTE: Loosening the strain relief (14) may require removing screws (15) so that the junction box can be moved.
6. Loosen the strain relief and remove the wiring for the meter from the fluid panel. If the solenoid is being replaced, remove the solenoid wiring from the strain relief and fluid panel.
NOTE: Remove fittings from old components and reinstall in new components as needed.
7. **If replacing the dispense valve:**
 - a. Perform steps 7.a - 7.d.
 - b. Place a wrench on the fitting (26) and disconnect the dispense valve.
NOTE: Use thread tape on supply line fittings.
 - c. Attach fitting (26) to the dispense valve.
 - d. Perform steps 7.a. - 7.d. in reverse order to install the meter and dispense valve.
 - e. Proceed to step 9.
8. **If replacing the solenoid and air valve (10):**
 - a. Shut off and bleed the air supply to the solenoid air valve.
 - b. Disconnect the inlet and outlet air lines at the solenoid air valve.
 - c. Remove screws (9) and remove the solenoid air valve.
 - d. Using screws (9), install the new solenoid air valve.
 - e. Attach the air lines to the solenoid air valve.
9. Route all removed wiring through the access hole on the side of the fluid panel and the junction box strain relief (14).
10. Refer to the schematic for the fluid panel junction box and attach all meter and solenoid wiring.
11. Position all wires passing through the junction box strain relief so that the terminal block connections are not under strain and tighten the strain relief. Do not overtighten.
12. If necessary, reattach the junction box to the fluid panel.
13. Attach the fluid panel top cover.
14. At the control panel, turn on the power.
15. Pressurize the air supply line and check for leaks.
16. If the fluid supply line was disconnected, under low pressure, load the fluid line and monitor for leaks at all fittings on the fluid panel. Tighten fittings as needed. If necessary, refer to [Loading Fluid Lines, page 36](#).
17. If necessary, calibrate the fluid panel.

Parts

Control Panel Parts

Part No. 26A070 Control Panel

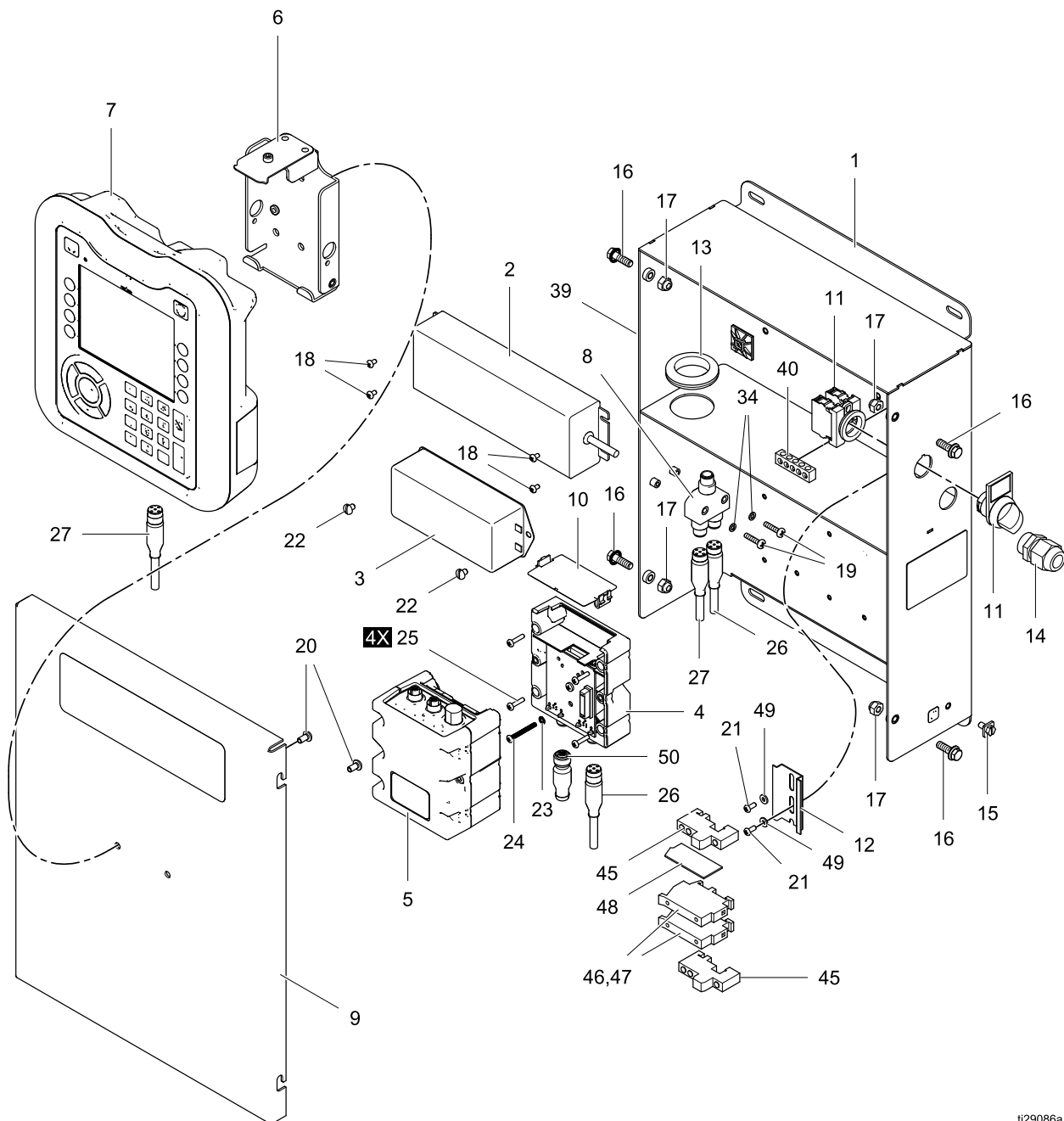

ti29086a

Parts

Part No. 26A070 Controller

Ref	Part	Description	Qty
1	-----	PANEL, system control	1
2	16T660	POWER SUPPLY, 24 VDC	1
3	16V446	FILTER, line power, 10A	1
4	289697	MODULE, GCA, cube, base	1
5	289696	MODULE, GCA, cube, FCM	1
6	-----	BRACKET, mounting, ADM	1
7	26A259	MODULE, GCA, ADM (includes token 17K873)	1
8	121807	CONNECTOR, splitter	1
9	-----	COVER, system control	1
10	-----	ENCLOSURE, cube door	1
11	16U725	SWITCH, selector, 2 position	1
12	-----	RAIL, DIN	1
13	-----	GROMMET, air fitting	1
14	110515	CONNECTOR, cord strain relief	1
15	-----	SCREW, ground	1
16	-----	SCREW, flanged, hex hd	4
17	-----	NUT, lock, hex	4
18	-----	SCREW, machine, bdgh	4
19	-----	SCREW, machine, pnh	2

Ref	Part	Description	Qty
20	-----	SCREW, machine, pnh	2
21	-----	SCREW, SEMS	2
22	-----	SCREW, machine	2
23	-----	WASHER, lock, #6	1
24	867551	SCREW, 6-3 2X 1.25, ph pn hd	1
25	-----	SCREW, machine, pan hd, #6 x .625	4
26	121000	CABLE, CAN, f/f 0.5 m	1
27	121003	CABLE, CAN, f/f 3.0 m	1
29	17M107	HARNESS, wiring	1
34	-----	WASHER, lock	2
35	17M094	LABEL	1
39▲	17L768	LABEL, warning (not shown)	1
40	-----	CONNECTOR, ground	1
45	-----	BLOCK, end	2
46	-----	HOLDER, fuse	2
47	114835	FUSE, time lag, 250V, 4A	2
48	-----	STOP, end, fuse holder	1
49	-----	WASHER, flat	2
50	120999	TERMINATION RESISTOR, CAN	1

Items marked ----- are not available separately.

▲ Replacement Warning labels are available at no cost.

Fluid Panel Parts

Part No. 26A071 Fluid Panel

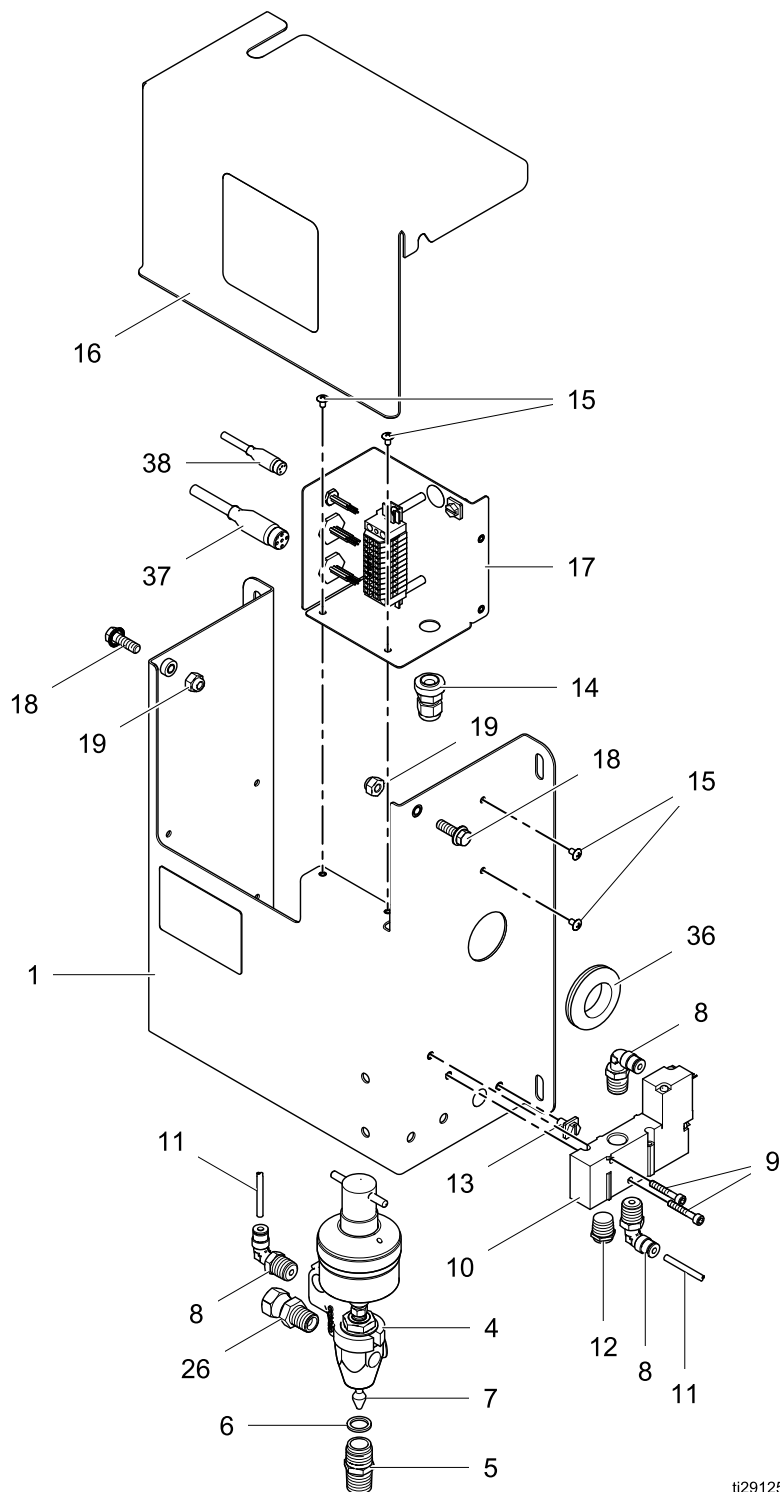

ti29125a

Parts

Part No. 26A071 Fluid Panel

Ref	Part	Description	Qty
1	— — —	PANEL, fluid	1
4	205612	VALVE, dispense, auto	1
5	164749	TIP, valve	1
6	164111	WASHER, non-metallic	1
7	181526	NEEDLE, fluid	1
8	— — —	ELBOW, m swivel	4
9	— — —	SCREW, cap, sch, sst	2
10	116463	VALVE, solenoid op, 3-way	1
11	598095	TUBE, 5.32 in. OD, nylon	6
12	— — —	MUFFLER	1
13	— — —	SCREW, ground	1
14	— — —	CONNECTOR, cord strain relief	1
15	— — —	SCREW, SEMS, machine, phillips, truss	4
16	— — —	COVER, fluid panel	1

Ref	Part	Description	Qty
17	26A072	JUNCTION BOX, fluid panel	1
18	— — —	SCREW, flanged, hex hd	2
19	— — —	NUT, lock, hex	2
26	156823	UNION, swivel	1
30▲	17L768	LABEL, warning (not shown)	1
36	— — —	GROMMET, air fitting	1
37		CABLE, m12, 5-pin, m/f, 50 ft (16 m)	1
	123659		1
	122030	1.5 ft (0.5 m)	1
38		CABLE, GCA, m8, 4-pin, m/f, 15 m	1
	17M099		1
	17M096	1.5 ft (0.5 m)	1

Items marked — — — are not available separately.

▲ Replacement Warning labels are available at no cost.

Fluid Panel Parts

Part No. 26A129 Fluid Panel

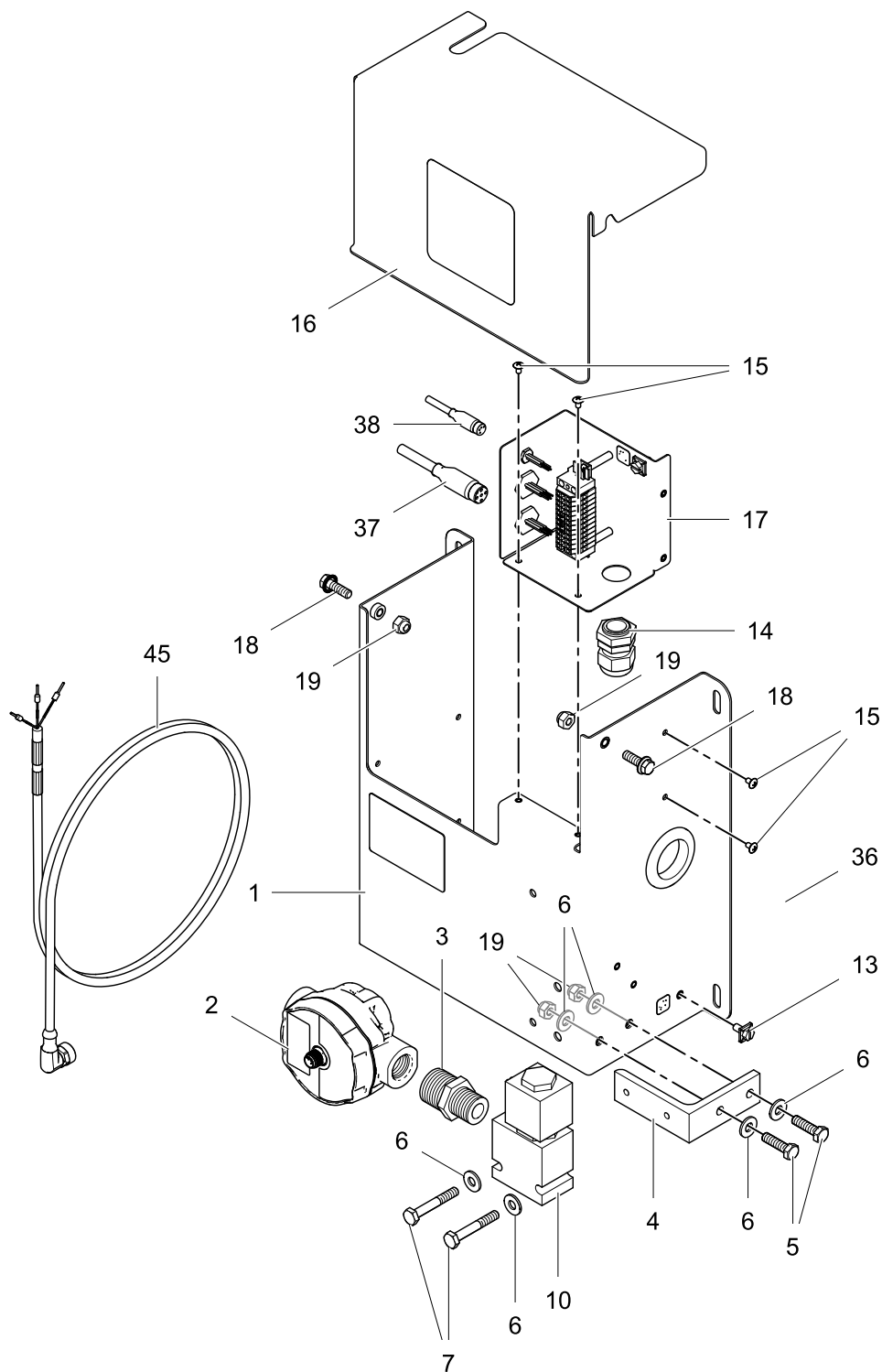

ti29121b

Parts

Part No. 26A129 Fluid Panel

Ref	Part	Description	Qty
1	— — —	PANEL, fluid	1
2	26C765	METER, electronic pulse	1
3	— — —	NIPPLE	1
4	— — —	BRACKET, solenoid mount	1
5	— — —	SCREW, cap hex hd	2
6	— — —	WASHER, plain	6
7	102313	SCREW, cap, hex, 1/4 in	2
10	— — —	VALVE, solenoid	1
13	— — —	SCREW, ground	1
14	— — —	CONNECTOR, cord strain relief	1
15	— — —	SCREW, SEMS, machine, phillips, truss	4
16	— — —	COVER, fluid panel	1
17	26A072	JUNCTION BOX, fluid panel	1
18	— — —	SCREW, flanged, hex hd	2
19	— — —	NUT, lock hex	4

Ref	Part	Description	Qty
25	223547	WIRE, assembly, 25 ft.	1
30▲	17L768	LABEL, warning (not shown)	1
36	— — —	GROMMET, air fitting	1
37	123659 122030	CABLE, m12, 5-pin, m/f, 50 ft (16 m) 1.5 ft (0.5 m)	1 1
38	17M099 17M096	CABLE, GCA, m8, 4-pin, m/f, 15 m 50 ft (16 m) 1.5 ft (0.5 m)	1 1
41	26C918	CABLE, water meter (not shown)	1
45	17K518	CABLE, CAN, 90, pigtail, f, 2 m	1

Items marked — — — are not available separately.

▲ Replacement Warning labels are available at no cost.

Fluid Panel Parts

Part No. 26A130 Fluid Panel

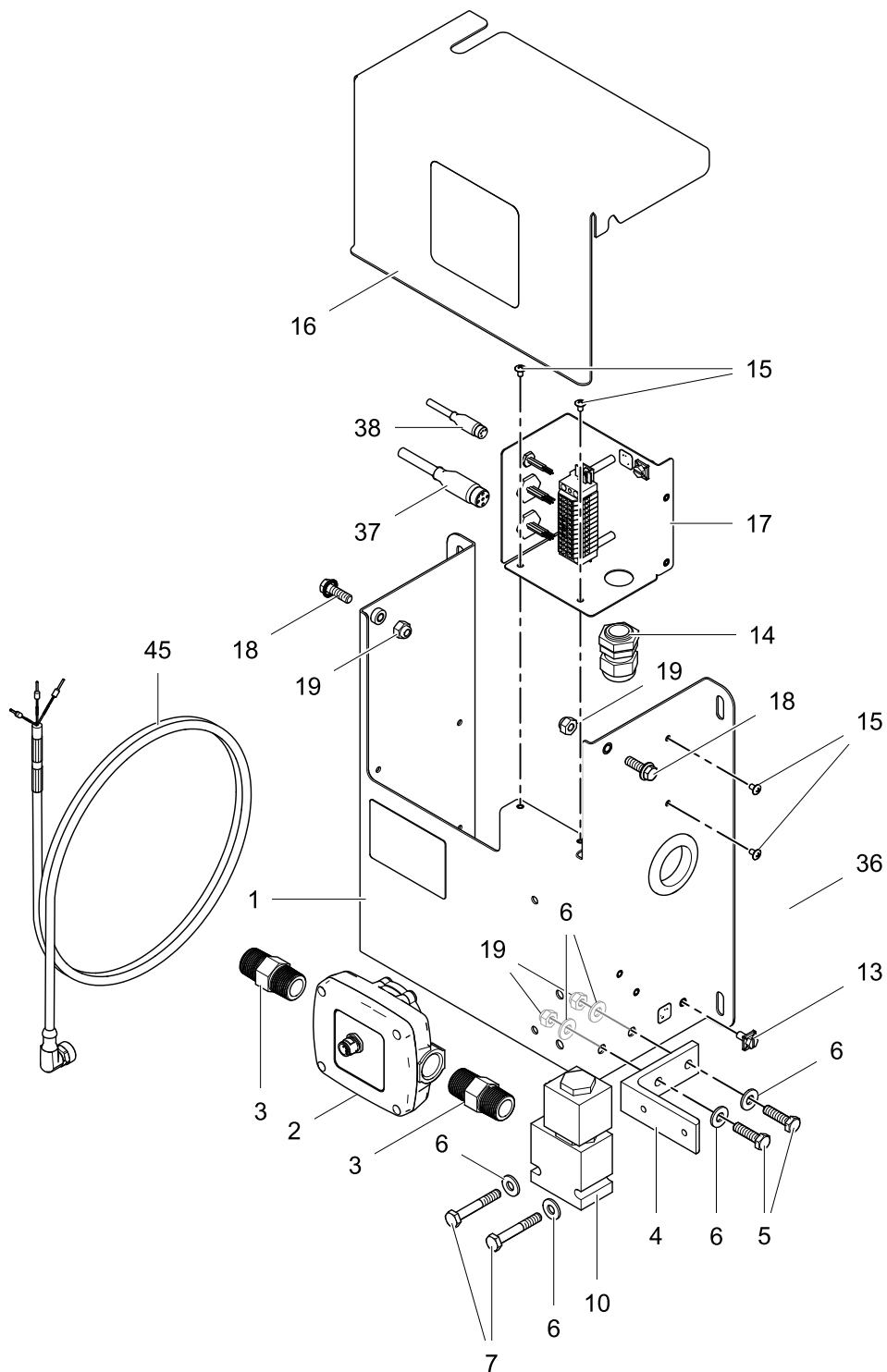

ti29122b

Parts

Part No. 26A130 Fluid Panel

Ref	Part	Description	Qty
1	----	PANEL, fluid	1
2	26C766	METER, pulse, water compatible, includes ref 2a	1
2a	----	FERRULE	2
3	----	NIPPLE	2
4	----	BRACKET, solenoid mount	1
5	----	SCREW, cap hex hd	2
6	----	WASHER, plain	6
7	102313	SCREW, cap, hex, 1/4 in	2
10	----	VALVE, solenoid	1
13	----	SCREW, ground	1
14	----	CONNECTOR, cord strain relief	1
15	----	SCREW, SEMS, machine, Phillips, truss	4
16	----	COVER, fluid panel	1
17	26A072	JUNCTION BOX, fluid panel	1
18	----	SCREW, flanged, hex hd	2
19	----	NUT, lock hex	4

Ref	Part	Description	Qty
23	----	FERRULE, wire, awg-18	2
25	----	WIRE, assembly, 25 ft.	1
30▲	17L768	LABEL, warning (not shown)	1
36	----	GROMMET, air fitting	1
37	123659	CABLE, m12, 5-pin, m/f, 50 ft (16 m)	1
	122030	1.5 ft (0.5 m)	1
38	17M099	CABLE, GCA, m8, 4-pin, m/f, 15 m 50 ft (16 m)	1
	17M096	1.5 ft (0.5 m)	1
41	26C918	CABLE, water meter (not shown)	1
45	17K518	CABLE, CAN, 90, pigtail, f, 2 m	1

Items marked — — — are not available separately.

▲ Replacement Warning labels are available at no cost.

Fluid Panel Parts

Part No. 26A131 Fluid Panel

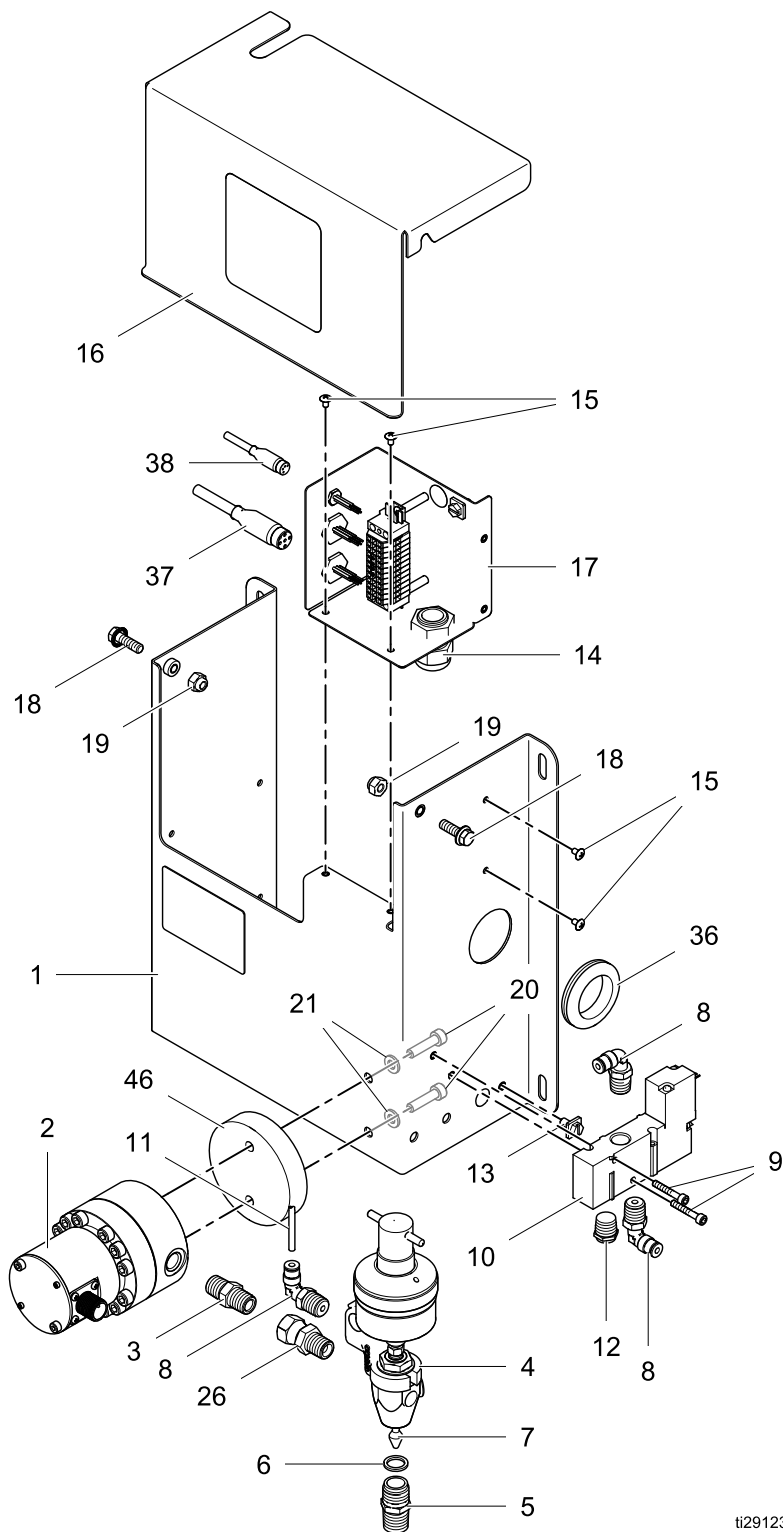

ti29123a

Parts

Part No. 26A131 Fluid Panel

Ref	Part	Description	Qty
1	— — —	PANEL, fluid	1
2	289813	METER, gear, assembly, G3000	1
3	156971	NIPPLE, short	1
4	205612	VALVE, dispense, auto	1
5	164749	TIP, valve	1
6	164111	WASHER, non-metallic	1
7	181526	NEEDLE, fluid	1
8	— — —	ELBOW, m swivel	4
9	— — —	SCREW, cap, sch, sst	2
10	116463	VALVE, solenoid op, 3-way	1
11	598095	TUBE, 5/32 in. OD, nylon	6
12	— — —	MUFFLER	1
13	— — —	SCREW, ground	1
14	— — —	CONNECTOR, cord strain relief	1
15	— — —	SCREW, SEMS, machine, phillips, truss	4
16	— — —	COVER, fluid panel	1
17	26A072	JUNCTION BOX, fluid panel	1
18	— — —	SCREW, cap, hex hd	2

Ref	Part	Description	Qty
19	— — —	NUT, lock, hex	2
20	— — —	SCREW, cap, hex hd	2
21	— — —	WASHER, plain	2
22	17C909	HARNESS, cable, G3000 16 in.	1
23	— — —	FERRULE, wire, awg-18	2
25	223547	WIRE, assembly, 25 ft.	1
26	156823	UNION, swivel	1
30▲	17L768	LABEL, warning (not shown)	1
36	— — —	GROMMET, air fitting	1
37		CABLE, m12, 5-pin, m/f, 50 ft (16 m)	1
	123659	50 ft (16 m)	1
	122030	1.5 ft (0.5 m)	1
38		CABLE, GCA, m8, 4-pin, m/f, 15 m	1
	17M099	50 ft (16 m)	1
	17M096	1.5 ft (0.5 m)	1
46	— — —	PLATE	1

Items marked — — — are not available separately.

▲ Replacement Warning labels are available at no cost.

Fluid Panel Parts

Part No. 26A132 Fluid Panel

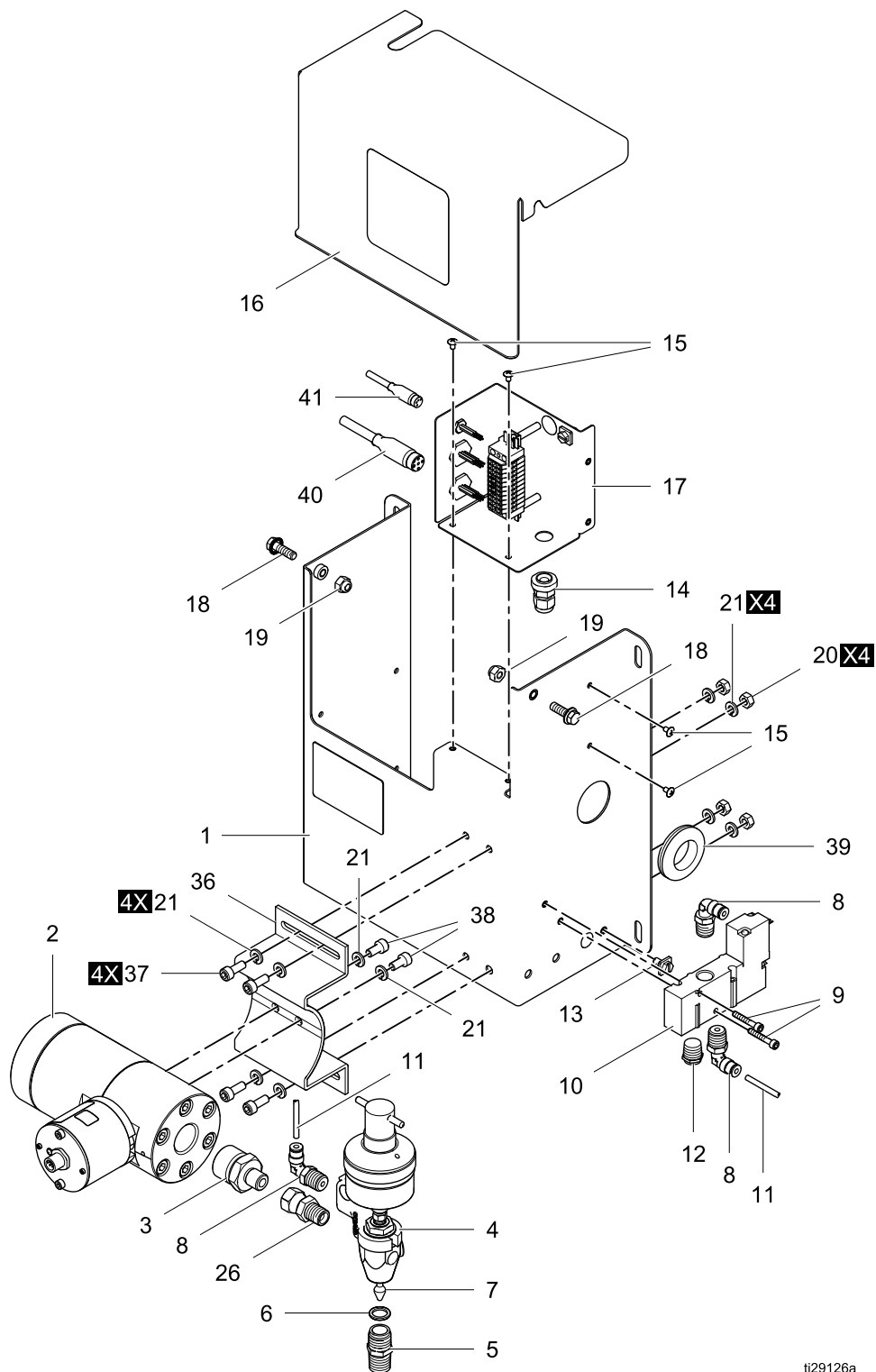

ti29126a

Parts

Part No. 26A132 Fluid Panel

Ref	Part	Description	Qty
1	----	PANEL, fluid	1
2	----	METER, heli gear, amb w/sensor	1
3	----	NIPPLE, reducing 3/4 in. x 1/4 in.	1
4	205612	VALVE, dispense, auto	1
5	164749	TIP, valve	1
6	164111	WASHER, non-metallic	1
7	181526	NEEDLE, fluid	1
8	----	ELBOW, m swivel	4
9	----	SCREW, cap, sch, sst	2
10	116463	VALVE, solenoid op, 3-way	1
11	598095	TUBE, 5/32 in. OD, nylon	6
12	----	MUFFLER	1
13	----	SCREW, ground	1
14	----	CONNECTOR, cord strain relief	1
15	----	SCREW, SEMS, machine, phillips, truss	4
16	----	COVER, fluid panel	1
17	26A072	JUNCTION BOX, fluid panel	1
18	----	SCREW, flanged, hex hd	2
19	----	NUT, lock, hex	2

Ref	Part	Description	Qty
20	----	NUT, hex	4
21	115226	WASHER, lock, spring, m6	10
22	----	CABLE, adapter, helical sensor	1
25	223547	WIRE, assembly, 25 ft.	1
26	156823	UNION, swivel	1
30▲	17L768	LABEL, warning (not shown)	1
36	----	BRACKET, helical gear, conversion	1
37	----	SCREW, schs me x 16	4
38	----	SCREW, cap, such, hex	2
39	----	GROMMET, air fitting	1
40		CABLE, Mme., 5th, m/f, 50 ft (16 m)	1
	123659		
	122030	1.5 ft (0.5 m)	1
41		CABLE, GCA, m8, 4-pin, m/f, 15 m	1
		50 ft (16 m)	
	17M096	1.5 ft (0.5 m)	1

Items marked ---- are not available separately.

▲ Replacement Warning labels are available at no cost.

Fluid Panel Parts

Part No. 26A165 Fluid Panel

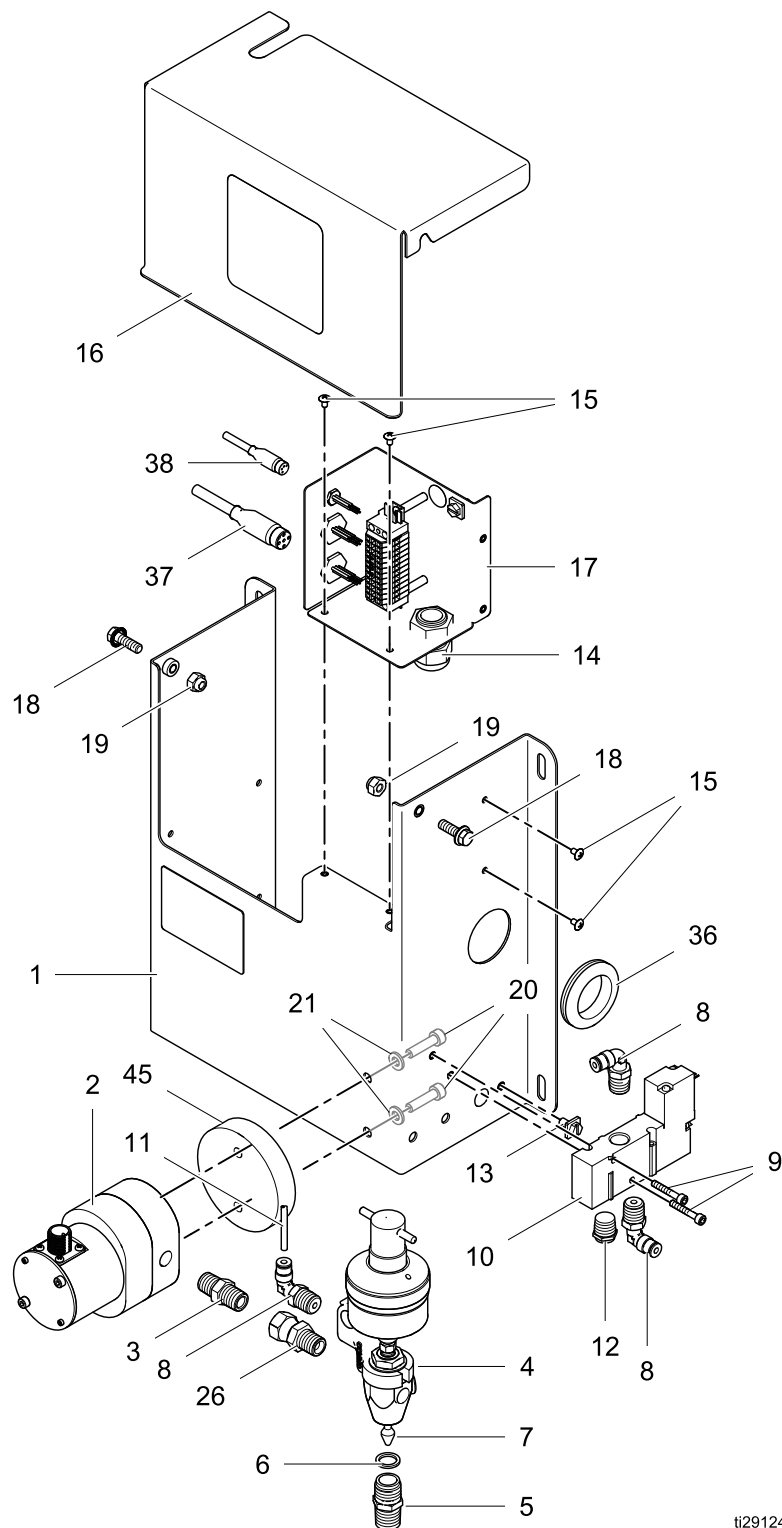

ti29124a

Parts

Part No. 26A165 Fluid Panel

Ref	Part	Description	Qty
1	— — —	PANEL, fluid	1
2	258718	METER, solvent, low flow, assembly	1
3	156971	NIPPLE, short	1
4	205612	VALVE, disp, auto	1
5	164749	TIP, valve	1
6	164111	WASHER, non-metallic	1
7	181526	NEEDLE, fluid	1
8	— — —	ELBOW, m swivel	4
9	— — —	SCREW, cap, sch, sst	2
10	116463	VALVE, solenoid op, 3-way	1
11	598095	TUBE, 5/32 in. OD, nylon	6
12	— — —	MUFFLER	1
13	— — —	SCREW, ground	1
14	— — —	CONNECTOR, cord strain relief	1
15	— — —	SCREW, sems, machine, phillips, truss	4
16	— — —	COVER, fluid panel	1
17	26A072	JUNCTION BOX, fluid panel	1
18	— — —	SCREW, flanged, hex hd	2

Ref	Part	Description	Qty
19	— — —	NUT, lock, hex	2
20	— — —	SCREW, cap, hex hd	2
21	— — —	WASHER, plain	2
22	17C909	HARNESS, cable, G3000 16 in.	1
23	— — —	FERRULE, wire, awg-18	2
25	— — —	WIRE, assembly, 25 ft.	1
26	156823	UNION, swivel	1
30▲	17L768	LABEL, warning (not shown)	1
36	— — —	GROMMET, air fitting	1
37		CABLE, m12, 5-pin, m/f,	
	123659	50 ft (16 m)	1
	122030	1.5 ft (0.5 m)	1
38		CABLE, GCA, m8, 4-pin, m/f, 15 m	
	17M099	50 ft (16 m)	1
	17M096	1.5 ft (0.5 m)	1
45	— — —	PLATE	1

Items marked — — — are not available separately.

▲ Replacement Warning labels are available at no cost.

Fluid Panel Parts

Part No. 26A247 Fluid Panel

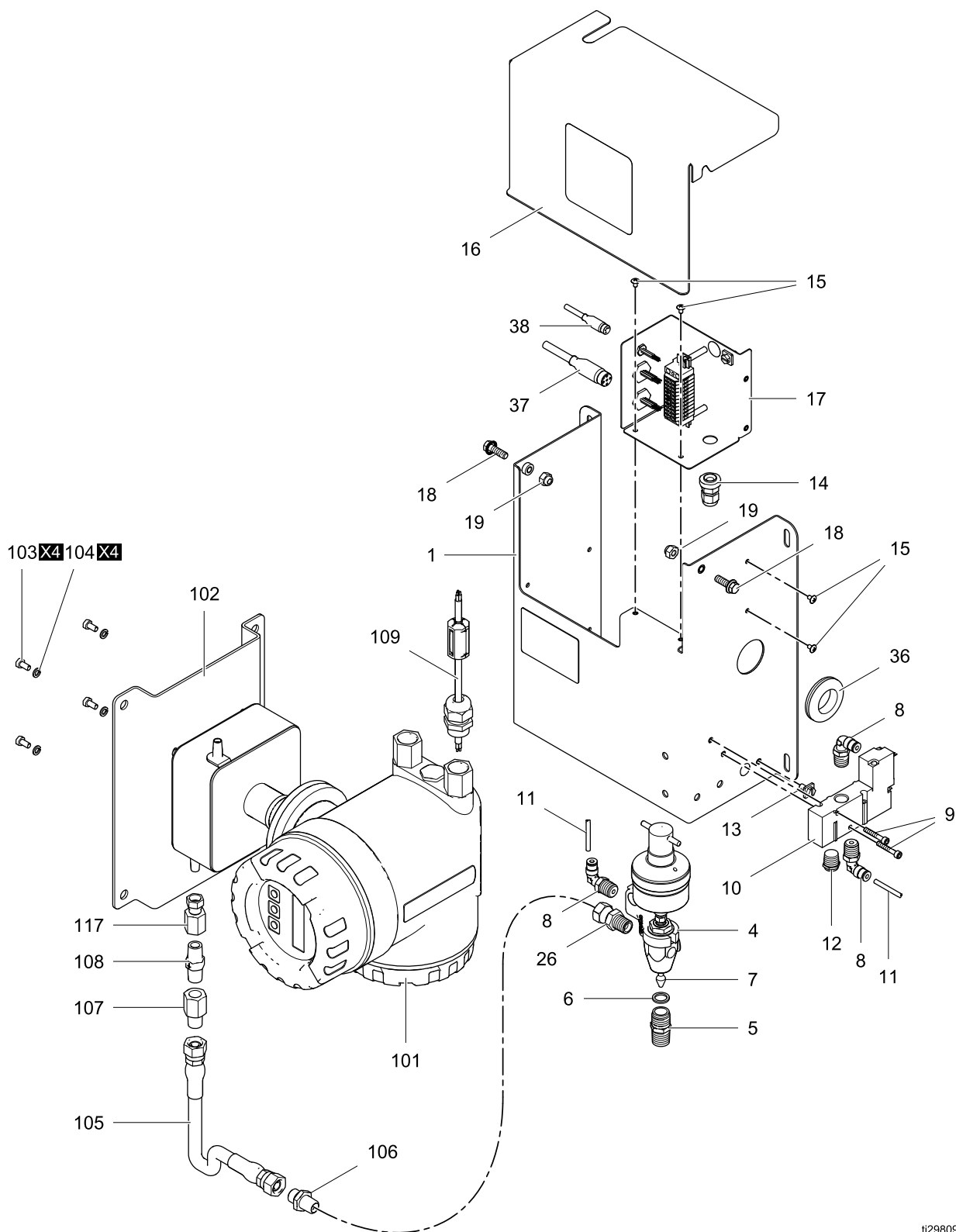

ti29809a

Parts

Part No. 26A247 Fluid Panel

Ref	Part	Description	Qty
1	— — —	PANEL, fluid	1
4	205612	VALVE, dispense, auto	1
5	164749	TIP, valve	1
6	164111	WASHER, non-metallic	1
7	181526	NEEDLE, fluid	1
8	— — —	ELBOW, m swivel	4
9	— — —	SCREW, cap, sch, sst	2
10	116463	VALVE, solenoid op, 3-way	1
11	598095	TUBE, 5.32 in. OD, nylon	6
12	— — —	MUFFLER	1
13	— — —	SCREW, ground	1
14	— — —	CONNECTOR, cord strain relief	1
15	— — —	SCREW, sems, machine, phillips, truss	4
16	— — —	COVER, fluid panel	1
17	26A072	JUNCTION BOX, fluid panel	1
18	— — —	SCREW, flanged, hex hd	2
19	— — —	NUT, lock, hex	2
26	156823	UNION, swivel	1
30▲	17L768	LABEL, warning (not shown)	1

Ref	Part	Description	Qty
36	— — —	GROMMET, air fitting	1
37		CABLE, m12, 5-pin, m/f,	
	123659	50 ft (16 m)	1
	122030	1.5 ft (0.5 m)	1
38		CABLE, GCA, m8, 4-pin, m/f, 15 m	
	17M099	50 ft (16 m)	1
	17M096	1.5 ft (0.5 m)	1
101	16M519	METER, coriolis	1
102	— — —	BRACKET	1
103	— — —	SCREW, cap, hex hd	4
104	— — —	WASHER, lock, spring	4
105	24N347	HOSE, coupled, 5.0 ft.	1
106	166846	FITTING, adapter	1
107	17A106	FITTING, adapter, 30 degree	1
108	501867	VALVE, check	1
109	258743	CABLE, installation	1
117	— — —	SWIVEL, union	1

Items marked — — — are not available separately.

▲ Replacement Warning labels are available at no cost.

Remote Operator Station Parts

Part No. 26A133 Remote Operator Station

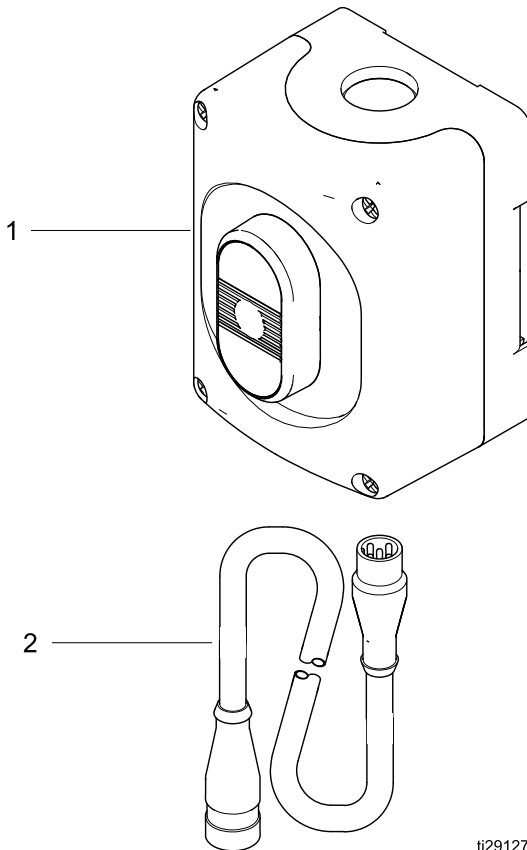

ti29127a

Part No. 26A133 Remote Operator Station

Ref	Part	Description	Qty	Items marked — — — are not available separately.
1	— — —	CONTROL, fluid	1	* Cable 122030 (1.5 ft) is available separately.
2	123659*	CABLE, 5-pin, m/f, 16 m	1	

FCM Parts

Part No. 26A134 FCM

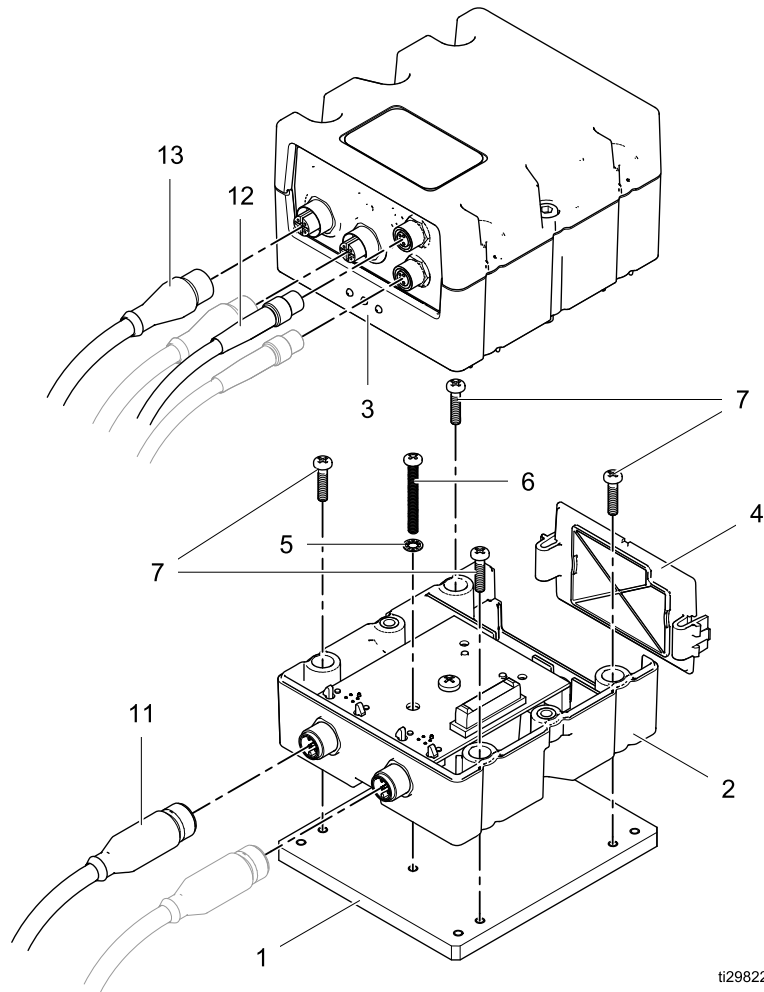

ti29822a

Ref	Part	Description	Qty
1	17K868	PLATE, adapter	1
2	289697	MODULE, base	1
3*	289696	MODULE, cube	1
4	— — —	DOOR, cube	1
5	— — —	WASHER, lock, #6	1
6	867551	SCREW, 6-32 x 1.25	1
7	— — —	SCREW, panhead #6 x 0.625	4
8	— — —	SCREW, 6-32 x 0.25	4
11	— — —	CABLE, CAN, 50 ft. (15 m)	1

* Kit 26A260 is available separately and contains this part and a token (17K873).

Glossary of Terms

Advanced Display Module (ADM) - the user interface for the system. See [Advanced Display Module \(ADM\), page 28](#).

Fluid Control Module (FCM) - the fluid controller for the system.

Fluid Panel/Fluid - Fluid panel

Grand Total - a non-resettable value that shows the total amount of material dispensed through the system.

Intrinsically Safe (IS) - refers to the ability to locate certain components in a hazardous location.

Job Total - a resettable value that shows the amount of material dispensed through the system for one job. A job is complete when the user presses the Job Complete key on the Booth Control or ADM.

K-Factor - the amount of material dispensed per stroke.

Purge - when all mixed material is flushed from the mix manifold, hose, and gun.

Recipe - preset, repeatable list of fluids, the order, and amounts to be dispensed

Run Screens - The Run screens provide a graphical depiction of system operation and current status. See [Run Mode Screens, page 93](#).

Setup Screens - The Setup screens allow the user to define the system, setup recipes, and establish system operating parameters. See [Setup Mode Screens, page 99](#).

Standby - refers to the status of the system.

Technical Data

ProDispense	U.S.	Metric
Power Requirements		
Electrical	85/240 VAC, 1.6 amp maximum, 50 or 60 Hz, single phase	
Pneumatic 26A071, 26A131, 26A132, 26A165	85–120 psi (0.59–0.82 MPa, 5.9–8.2 bar) at 1/4 cfm maximum (filtered to 10 micron)	
Number of fluids	1–8 fluid panels NOTE: See Appendix B - System Design, page 114 for information on the power consumption for each system component. This may affect how many fluid panels can be used with this system.	
Totalizers	Last Dispense; Resettable; Grand	
Number of Recipes	50 maximum	
Operating Temperature	40–121°F	4–50°C
Weight (Control panel and ADM only)	25 lb	11.3 kg

Fluid Panels	U.S.	Metric
26A129 Oil/Lubricant Oil meter		
Flow rate	0.25–20 gpm	0.95–75.7 lpm
Viscosity range	10 wt. oil – 90 wt. oil	
Accuracy	See Dispense Accuracy, page 40	
Resolution	5.48 cc/pulse	
Maximum working pressure	2000 psi	13.8 MPa, 138 bar
Fluid inlet	3/4 npt(f)	
Fluid outlet	3/4 npt(f)	
Weight	12.5 lb	5.7 kg
26A130 Water/Antifreeze (not ETL listed) Water meter		
Flow rate	0.5–5 gpm	1.9–19 lpm
Viscosity range	1 – 20 cps	
Accuracy	See Dispense Accuracy, page 40	
Resolution	2.82 cc/pulse	
Maximum working pressure	500 psi	3.4 MPa, 34 bar
Fluid inlet	1/2 npt(f)	
Fluid outlet	1/2 npt(f)	
Weight	13 lb	5.9 kg

Fluid Panels	U.S.	Metric
26A131 Grease/Paint G3000 meter		
Flow rate	0.02–1 gpm	0.76–3.8 lpm
Viscosity range	20–3000 cps	
Accuracy	See Dispense Accuracy, page 40	
Resolution	0.119 cc/pulse	
Maximum working pressure	3000 psi	21 MPa, 207 bar
Maximum air pressure	120 psi	0.8 MPa, 8 bar
Fluid inlet	1/4 npt(f)	
Fluid outlet	3/8 npt(m)	
Air inlet	1/4 npt(f)	
Weight	18.5 lb	8.4 kg
26A165 Solvent S3000 meter		
Flow rate	0.01–0.42 gpm	0.05–1.6 lpm
Viscosity range	20–500 cps	
Accuracy	See Dispense Accuracy, page 40	
Resolution	0.020 cc/pulse	
Maximum working pressure	3000 psi	21 MPa, 207 bar
Maximum air pressure	120 psi	0.8 MPa, 8 bar
Fluid inlet	1/4 npt(f)	
Fluid outlet	3/8 npt(m)	
Air inlet	1/4 npt(f)	
Weight	18.5 lb	8.4 kg
26A132 Grease/Paint/Sealant HG6000 meter		
Flow rate	0.1–6 gpm	0.05–22.7 lpm
Viscosity range	30–1,000,000 cps	
Accuracy	See Dispense Accuracy, page 40	
Resolution	0.286 cc/pulse	
Maximum working pressure	3000 psi	21 MPa, 207 bar
Maximum air pressure	120 psi	0.8 MPa, 8 bar
Fluid inlet	3/4 npt(f)	
Fluid outlet	3/8 npt(m)	
Air inlet	1/4 npt(f)	
Weight	29 lb	13.2 kg

Technical Data

Fluid Panels	U.S.	Metric
26A247 Shear Sensitive/Fiber-filled Coriolis meter		
Flow rate	0.005–1.6 gpm (20–4000 cc/min)	0.019–6.06 lpm
Viscosity range	20–5000 cps	
Accuracy	see Endress+Hauser manual	
Resolution	settable 0.020-0.150 cc/pulse	
Maximum working pressure	2300 psi	15.9 MPa, 159 bar
Maximum air pressure	120 psi	0.8 MPa, 8 bar
Fluid inlet	1/4 nps(m)	
Fluid outlet	3/8 npt(m)	
Air inlet	1/4 npt(f)	
Weight	28.5 lb	12.9 kg
26A071 Meter-less (flow meter supplied by user)		
Flow rate	User supplied Refer to meter manufacturer's manual	
Viscosity range		
Accuracy		
Resolution		
Input signal range	0–24 VDC	
Trigger voltages	H to L transition: 5V L to H transition: 12V	
Minimum pulse width	300 µs	
Maximum working pressure	3000 psi	21 MPa, 207 bar
Maximum air pressure	120 psi	0.8 MPa, 8 bar
Fluid inlet	User supplied Refer to meter manufacturer's manual	
Fluid outlet	1/4 npt(f)	
Air inlet	1/4 npt(f)	
Weight	11.5 lb	5.2 kg

Wetted Parts

26A129	Aluminum, stainless steel, carbon steel, acetal, nitrile rubber, Geolast™
26A130	Nickel, zinc, PTFE, ETFE, LCP, polyolefm, nitrile rubber, aluminum, zinc plating, carbon steel
26A131	303, 313, 316, 400 series, and 416 stainless steel, Tungsten carbide, PTFE, carbon steel, chrome, UHMWPE, leather
26A132	303, 313, 316, 416, 440 stainless steel, PTFE, carbide, carbon steel, chrome, UHMWPE, leather
26A165	303, 313, 316, 416, 17–4 stainless steel, PTFE, carbon steel, chrome, UHMWPE, leather
26A247	1.4539/904L stainless steel alloy, C-22.2.4602/N 06022, 303, 304, 313, 316, 416 stainless steel, PTFE, carbon steel, chrome, UHMWPE, leather
25A071	313, 316, 416 stainless steel, carbon steel, chrome, UHMWPE, leather

California Proposition 65

CALIFORNIA RESIDENTS

 **WARNING:** Cancer and reproductive harm — www.P65warnings.ca.gov.

Notes

Notes

Appendix A – Advanced Display Module (ADM) Operation

Run Mode Screens

NOTE: Selection fields and buttons that are grayed-out on the screens are not currently active.

Splash Screen

At power up, the Graco logo will display for approximately 5 seconds, followed by the Home screen.



NOTE: The ADM will start the Run screens at the Home screen. From the Run screens, press  to access the Setup screens.

Home Screen

The Home screen displays the current status of the system. The following table details the information shown.

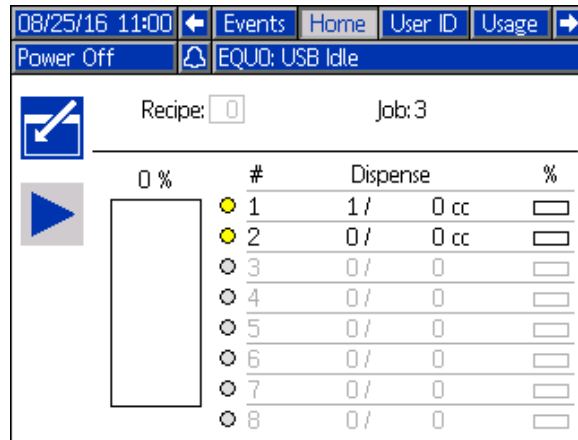

Description	Details
Job Details	<p>Displays details about the current job:</p> <ul style="list-style-type: none"> • Recipe: Recipe to dispense • Job: Current job number, automatically increments with each completed job • Main % bar: Represents the percentage of total recipe dispensed • List of fluid panels: <ul style="list-style-type: none"> – Fluid Status Indicator: <ul style="list-style-type: none"> ○ Disabled or Offline ● Power Off mode ● Standby On mode ● Currently Dispensing ● Error – Fluid Number – Current and Target Dispense Volume – Percentage of individual fluids dispensed OR if in diagnostic mode, displays individual fluid flow rate <p><u>% values during dispensing</u></p> <p>Red Done dispensing, out of tolerance Green Done dispensing, within tolerance Orange Currently dispensing</p>

User ID Screen

The User ID screen displays a custom user ID and associated job IDs. This information is associated with each job log and logged. It is possible to download these logs to a USB drive. See [USB Download Procedure, page 42](#).

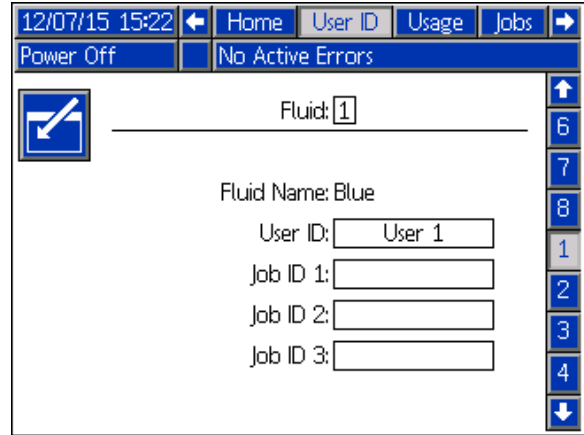

Field	Description
Fluid:	The number of the fluid panel being defined. Numeric value, 1–8. Entering a value for a fluid panel which has not been defined is not allowed.
Fluid Name:	Name assigned to this fluid panel on the Fluid screen. See Fluid Screen, page 103 .
User ID:	Optional. Name assigned by individual user. This User ID will appear in the job log. Field can contain up to 10 alphanumeric characters and spaces.
Job ID 1:	Optional. Job ID assigned by individual user. This Job ID will appear in the job log. Field can contain up to 10 alphanumeric characters and spaces.
Job ID 2:	Optional. Job ID assigned by individual user. This Job ID will appear in the job log. Field can contain up to 10 alphanumeric characters and spaces.
Job ID 3:	Optional. Job ID assigned by individual user. This Job ID will appear in the job log. Field can contain up to 10 alphanumeric characters and spaces.
Numbers on vertical elevator bar	One number for each possible Fluid Panel. Use the up/down arrow keys to navigate, or enter the desired value in the Fluid: field.

Typewriter Keyboard

NOTE: When typing numbers, the on-screen keyboard or the ADM number keypad can be used.

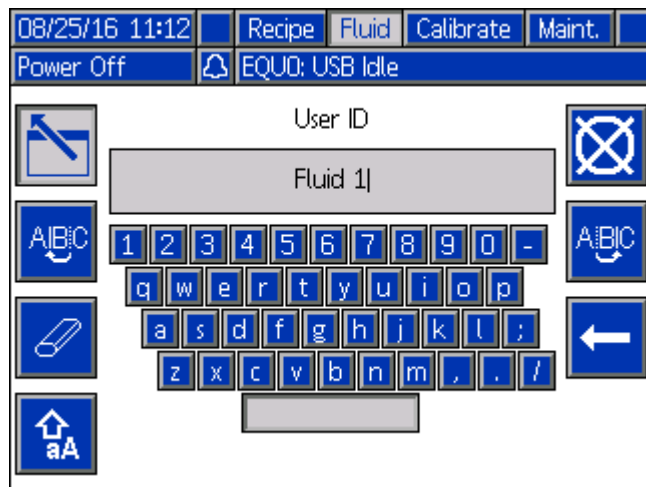

Usage Screen

The Usage screen displays information about fluid panel usage and total job dispense volume. The Totalizer fields can be reset.

05/20/16 13:58		User ID	Usage	Jobs	Events
Power Off		EQUO: USB Idle			
#	Grand Total (L)	Valve	Totalizer (L)	Reset	
1	14193	585	0.59	<input type="checkbox"/>	
2	0	0	0.00	<input type="checkbox"/>	
3	0	8	0.00	<input type="checkbox"/>	
4	0	4	0.00	<input type="checkbox"/>	
5	0	0	0.00	<input type="checkbox"/>	
6	0	0	0.00	<input type="checkbox"/>	
7	0	0	0.00	<input type="checkbox"/>	
8	0	0	0.00	<input type="checkbox"/>	
			0.59	<input type="checkbox"/>	

Field	Description
#	Fluid number. Undefined fluid panels are grayed out.
Grand Total (L or gal)	Based on the units value selected on Advanced Screen 2.
Valve	Number of times the dispense valve has been activated.
Totalizer (L or gal)	Based on the units value selected on Advanced Screen 2.
Reset	Reset the selected Totalizer value.

Jobs Screen





The Jobs screen displays the 990 most recent job numbers, recipes, fluid panel numbers, and dispense volumes; with date, time, and User ID. All logs listed can be downloaded on a USB flash drive. See [USB Download Procedure, page 42](#).



08/25/16 17:09		Usage	Jobs	Events	Home		
Power Off		No Active Errors					
12/07/15	14:55	User 1	00294	3	1	77 cc	
12/07/15	14:01	User 1	00293	3	1	77 cc	
12/07/15	12:35	User 1	00292	3	1	76 cc	
12/07/15	12:35	User 1	00291	3	1	35 cc	
12/07/15	12:34	User 1	00290	3	1	34 cc	
12/07/15	12:20	User 1	00289	3	1	34 cc	
12/07/15	12:18	User 1	00288	3	1	67 cc	
12/07/15	12:17	User 1	00287	3	1	66 cc	
12/04/15	19:16	User 1	00286	2	1	12 cc	
12/03/15	16:01		00285	1	2	5 cc	

Field	Description
	Date: The date the job occurred. The date format appears in the format selected on advanced screen 1 at the time of the occurrence. If the date format is changed on advanced screen 1 after the job occurs, the date here will remain as it was when the job was completed.
	Time: The time the job began.
	User ID: User-defined value. If no value has been defined for the selected job, this value is blank.
	Job Number: System-assigned as each recipe or station dispense job begins.
	Recipe number: Number of the recipe that performed the dispense. If the dispense was done in Station mode or Top Off mode, no recipe number is shown.
	Fluid number: Number of the fluid panel that performed the dispense.
	Volume: Amount of material dispensed.
Numbers on vertical elevator bar	Total number of screens with jobs listed. A system will begin with only one screen number. As a new job is added, it is the top entry on screen 1 and all other jobs move down one position. When screen 1 is full, a new screen is created at the end of the number list. Jobs are moved down to subsequent screens as the list grows. When the maximum number of screens is reached (99), jobs moved off the data at the bottom of the last screen are no longer displayed. The job data will remain available in the job log unless the job log has reached its maximum content.



Events Screen

The Events screen displays the 990 most recent Event Codes in a log, with date, time, and description. All events can be downloaded on a USB flash drive.

05/20/16 13:55		←	Jobs	Events	Home	User ID	→
Power Off		↻	EQUO: USB Idle				
							
05/20/16	12:55	EB00-V	Stop Button Pressed				10
05/20/16	12:55	EAUX-V	USB Busy				11
05/20/16	12:55	CDG1-V	Duplicate Gateway Modbus TCP				12
05/20/16	12:55	CDG0-V	Duplicate Gateway Modbus TCP				13
05/20/16	12:55	CDGX-V	Duplicate Gateway				14
05/20/16	12:55	CDCF-V	Duplicate Fluid Module 15				15
05/20/16	12:55	CDCE-V	Duplicate Fluid Module 14				16
05/20/16	12:55	CDCD-V	Duplicate Fluid Module 13				
05/20/16	12:55	CDCC-V	Duplicate Fluid Module 12				
05/20/16	12:55	CDCB-V	Duplicate Fluid Module 11				

Field	Description
	Date: The date the event occurred. The date format appears in the format selected on advanced screen 1 the time of the occurrence. If the date format is changed on advanced screen 1 after the event occurs, the date here will remain as it was when the event occurred.
	Time: The time the event occurred.
	Alarm code: Code of the generated event. See Errors, page 47 for more information.
Numbers on vertical elevator bar	Total number of screens with events listed. A system will begin with only one screen number. As a new event is added, it is the top entry on screen 1 and all other events move down one position. When screen 1 is full, a new screen is created and added to the number list. Events are moved down to subsequent screens as the list grows.

Setup Mode Screens

The ADM will start the Run screens at the Home screen, From the Run screens, press  to access the Setup screens. The system defaults with no password, entered as 0000. If requested, enter the current password then press . Press the left/right arrows to navigate through the Setup Mode screens.

NOTE: Selection fields and buttons that are grayed-out on the screens are not currently active.

System Screen

The System screen includes the following fields which define your system.

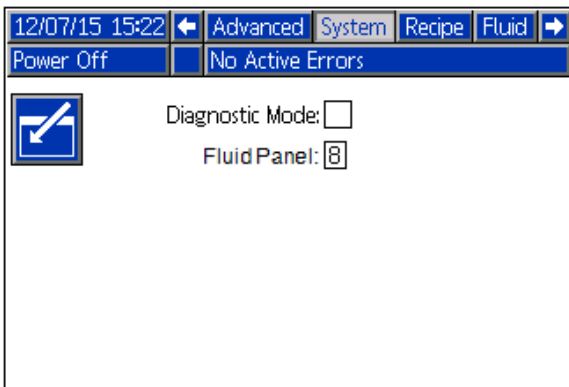

Field	Description
Diagnostic Mode	Enables/disables individual fluid flow rates that are displayed on the Run screen.
Fluid Panel	The number of fluid panels used in the system. Up to eight fluid panels are possible.

Recipe Screen

The Recipe screen can be used to create and manage up to 50 recipes. Each line on the Recipe screen corresponds to one dispense batch or time delay within a recipe, with a maximum of ten items per recipe. The first screen contains items 1–5 and the second screen contains items 6–10.

#	Fluid	Target	Tolerance	Timeout	Order
1	1	100 cc	0 %	0 sec	1
2	2	200 cc	0 %	0 sec	2
3	3	150 cc	0 %	0 sec	3
4	0	0 sec	0 %	0 sec	1
5	0	0 sec	0 %	0 sec	1

Field	Description
Recipe	Enter a value to select a specific recipe. An alternate method for recipe selection can be done by using the up/down arrow keys.
Enabled	If an X is displayed in this box, the recipe is available for use by the system. If the box is empty, this recipe is not available for use. Leave this box empty until all items have been defined as desired for this recipe.
#	Item number: Each recipe can contain up to 10 items. Multiple items can occur simultaneously. This is not the order in which things will occur. Refer to the Order field to specify which items will occur and their order.
Fluid	Number of the fluid panel that will dispense fluid. If a value of 0 is used, this item can define a time value only. All other fields to the right for this item are disabled. A time value can be used to delay when the next item, based on the Order field, will occur. For example, if a time delay is chosen as order 2, the fluid dispensed as order 3 will not dispense until the order 2 duration has completed. NOTE: If a valid fluid has been defined in the past but the field now displays a red background, that fluid is either disabled or offline. If a value is entered for a fluid which has not been defined, such as trying to select a “3” when only fluid panels 1 and 2 exist, this field will display an “0” and set the Order field to “99”. To correct the Order field will require entering a valid fluid value, changing the order field, and then changing the Fluid field back to a “0”.
Target	Numeric value (“999” (sec/Oz/cc) or “999.99” (L/gal)) When a non-zero value is entered in the Fluid field, the Target field changes over to the dispense value defined in Fluid Screen, Volume Units Field for this particular fluid. Since different fluids may dispense in different volume units, different values may appear on this screen. See Fluid Screen, page 103 for more information regarding Volume Units.
Tolerance	Define how much volume tolerance can occur from the value defined in the Target field before an alarm is triggered. This value only applies to volume shortage or overage. The tolerance is disabled for timer presets. 0 = No tolerance check 1 – 99 = Percentage of deviation short/over Target value that will cause alarm NOTE: A setting of 5 would mean 95-105% of Target value is acceptable.

Field	Description
Timeout	Allowed time in seconds for dispensing of the selected fluid. The Timeout is disabled for timer presets. 0 = No timeout limit 1 – 99 Number of seconds allowed to dispense; if the Tolerance field is a zero, this value does not apply.
Order	Numeric value 0–10. Defines the order in which defined items will occur. Multiple items can occur at the same time. It is not necessary for each item to have a different order number. It is not necessary to use sequential order numbers. NOTE: A value of 99 with a red background will appear if the chosen fluid and entered order number combination have already been defined for this recipe. Check the other screen for this recipe to verify that is the case. 0 = Fluid panel is operating in Station Mode and can dispense at any time during the recipe 1 – 10 = The order to perform the specified items
Numbers on vertical elevator bar	Numeric values, 1/2 or 1–50 1 or 2 appear when defining a recipe. During definition, the first screen contains items 1–5 and the second screen contains items 6–10. Items can appear on either screen and do not require entry in sequential or contiguous order. 1–50 appear when a recipe is not being defined. These numbers correlate with available recipes. The desired recipe can be reached using the ADM up/down keys or by entering the desired number in the Recipe field.

Setup Recipes

Each recipe can contain up to 10 preset items, which appear on 2 separate screens for each recipe. When defining a recipe, the preset items do not require sequential or contiguous entries.

NOTE: Since the unit of dispense depends on the configuration of the fluid panel, it is recommended that the fluid panels be configured before defining recipes.

Presets for a recipe are defined in the recipe screens 1 and 2 for each recipe.

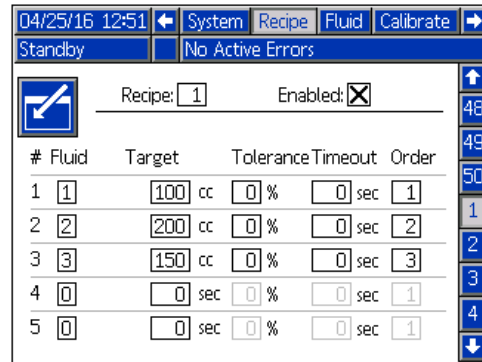

Recipe 1, Screen 1 shown

Recipe Example

For this example, the table defines how the fluid panels are defined for this example system and how the recipe might appear to dispense the following liquids for a motor vehicle:

- 5 quarts of motor oil
- 12.5 quarts of transmission fluid
- 1.5 gallons of water, mixed with 1.5 gallons of antifreeze by dispensing simultaneously but in segments to allow the engine to be started to circulate the liquid.

Fluid Panel	Fluid	Volume Unit	Required Volume
1	Water	gal	1.5 gal
2	Antifreeze	gal	1.5 gal
3	Motor Oil	Oz	5 quarts (160 Oz)
4	Transmission Fluid	gal	12.5 quarts (3.125 gal)

The desired order of events will be:

1. Dispense all needed motor oil within 10 minutes.
2. Dispense all needed transmission fluid within 10 minutes after the motor oil is dispensed.
3. Dispense 0.5 gal each of water and antifreeze simultaneously.
4. Allow 60 seconds to start engine so that coolant can begin circulation.
5. Dispense remaining water and antifreeze simultaneously within 3 minutes.

NOTE: The failure to dispense remaining water and antifreeze could result in the engine overheating. If the dispense has not been completed within that time, an alarm will result.

To perform these steps will require the recipe to be configured as follows:

NOTE: When a non-zero value is entered in the Target field, the Volume units will change to reflect the setting for that fluid in the Fluid screen. If they are not in the units desired, it will be necessary to either change them on the Fluid screen, or convert the desired volume to the Volume units shown on the screen.

#	Fluid	Target	Tolerance (%)	Timeout (sec)	Order
---	-------	--------	---------------	---------------	-------

Entries on screen 1:

1	3	160 (Oz)	0	600	1
2	4	3.125 (gal)	0	600	2
3	1	0.5 (gal)	0	0	3
4	2	0.5 (gal)	0	0	3
5	0	60 (sec)	—	—	4

Entries on screen 2:

6	1	1.0 (gal)	0	180	5
7	2	1.0 (gal)	0	180	5
8	—	—	—	—	—
9	—	—	—	—	—
10	—	—	—	—	—

Verify that the Volume units are for the quantities desired for this recipe.

Select the Enabled checkbox, making this recipe available for dispensing.

Fluid Screen

The Fluid screen is used to manage fluids and their units, and whether they are dispensed manually or by a preset recipe.

Fluid Screen

Fluid Screen with Auto Adjust

Fluid Screen in Station Mode

Fluid Screen with Fluid Disabled

Field	Description
Fluid:	The number of the fluid panel being defined. If a fluid panel does not exist with the selected number, it will not remain, but will revert to an "8" with a red background.
Enabled:	Used to make the selected fluid available for use by recipes or by the fluid panel being operated in station mode. Station mode fluid dispensing is controlled by a remote operator station at the fluid panel. Selected: This fluid can be dispensed. Deselected: This fluid can not be dispensed.
FCM3 ID:	Indicates the FCM number within the system layout. Valid values 0–3, depending on total number of fluid panels installed.
FCM3 Port:	Select which FCM ports the selected fluid panel is connected to. Blue (1,4) Red (2,3)

Field	Description
Fluid Name:	Alphanumeric field. Select the  key to display the on-screen keyboard. Enter a name for the selected fluid panel. Maximum name length 10 characters. An entry is not required.
K Factor:	Numeric value (0.001–999.999). Default value = 0.119. Enter the K-factor for the flow meter used on the selected fluid panel. To determine the exact value to enter, run calibration on this fluid plate. See Calibrate Screen, page 106 .
Volume Units:	Select the desired units of volume to use during dispensing. <ul style="list-style-type: none"> • cc • Oz • L • gal <p>NOTE: Changing this setting after recipes have been created can result in dispensing error. Always review recipes after changing this setting.</p>
Leak :	The allowed tolerance before a leak triggers an alarm. Leak detection is active in Standby, On, and Pause modes; and monitors leak volume within past minute. <ul style="list-style-type: none"> • Range — 0.0–99.9 cc/min • Default — 0.0 cc/min
Settling Time:	Enter the time necessary for the system to physically settle after dispense is done. <ul style="list-style-type: none"> • Range — 0.00–99.99 sec • Default — 0.00 sec
Auto Adjust:	Selecting “Auto Adjust” will allow the system to compensate for dispense overshoots.
Mode:	Toggles between Recipe and Station modes. <ul style="list-style-type: none"> • Recipe — Fluid dispense controlled by recipe. • Station — Each fluid panel acts as independent fluid dispenser with the following Station-only options: <ul style="list-style-type: none"> – Stop – Target – Tolerance – Timeout – Top Off
Stop Btn.:	Configure the function of the Stop button for the remote operator station. <ul style="list-style-type: none"> • Standby — The Stop button will finish dispense at any given time by putting system in standby. • Pause — The Stop button will pause the current dispense. The dispense Timeout timer (if configured) will continue running. • Pause-Standby — The Stop button will pause the current dispense, or will finish dispense if the button is held for two seconds.

Field	Description
Target (cc, Oz, L, gal):	<p>Enter the target dispense volume for Station mode.</p> <ul style="list-style-type: none"> • Range (gal and L) — 0–999.99 • Range (Oz and cc) — 0–999 • Default — 0 <p>NOTE: Target is reset on unit change.</p>
Tolerance (%):	<p>Enter the allowed dispense tolerance, as a percentage, before an alarm is triggered.</p> <ul style="list-style-type: none"> • Range — 0 (Tolerance off) - 99% • Default — 0%
Timeout (sec):	<p>Enter the allowed time to dispense before the timeout alarm is triggered.</p> <ul style="list-style-type: none"> • Range — 0 (no Timeout) - 999 sec • Default — 0 sec
Top Off (sec)	<p>Enter the allowed time to “top off”, after which the system will go into Standby mode.</p> <ul style="list-style-type: none"> • Range — 0–999 sec • Default — 0 sec
Numbers on vertical elevator bar	<p>One number for each possible Fluid Panel. Use the up/down arrow keys to navigate, or enter the desired value in the Fluid field.</p>

Some fields are only available for edit if the fluid panel is in Station Mode. These fields are only applicable when the fluid panel is dispensing while in Station Mode. If a recipe calls for this fluid panel

to dispense while in Station Mode, the recipe must specify the amount to dispense and have an Order of 0 for this fluid panel.

Calibrate Screen

The Calibrate screen is used to individually calibrate each fluid panel flow meter.

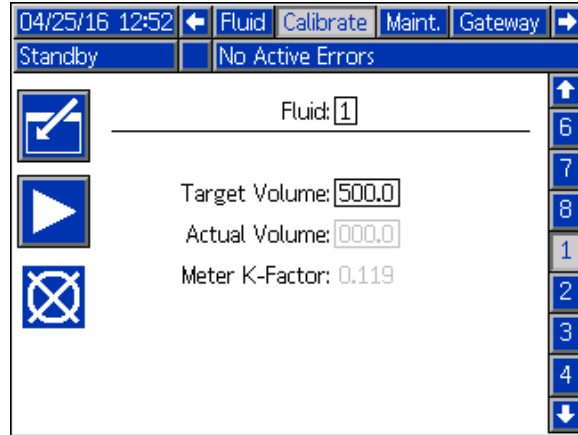

Field	Description
Fluid:	Displays the current fluid panel. Enter a number of a different panel or use the up/down arrows to select another fluid panel.
Target Volume:	Enter the target calibration volume (in cc). <ul style="list-style-type: none"> • Range — 0–999.9 • Default — 500
Actual Volume:	Set/enter the actual calibration volume (in cc) dispensed. <ul style="list-style-type: none"> • Range — 0–999.9 • Default — 0
Meter K-Factor:	Displays the calculated K-Factor. This value can only be changed on the Fluid Screen. See Fluid Screen, page 103 .
Numbers on vertical elevator bar	One number for each possible Fluid Panel. Use the up/down arrow keys to navigate, or enter the desired value in the Fluid: field.

Calibration Procedure

Prior to dispensing fluids in a production environment, it is necessary to calibrate each fluid panel to ensure accurate dispense.

NOTE: Prior to performing this procedure, the supply line must be loaded and pressurized. See [Loading Fluid Lines, page 36](#).

Navigate to the Calibrate screen on the ADM.

1. Select the fluid panel to calibrate by using the Up/Down arrows or entering the fluid panel number in the **Fluid** field.
2. Enter the target calibration volume in the **Target Volume** field.
3. Use a calibrated beaker able to measure the targeted calibration volume.

4. Press Play softkey to start calibration.

NOTE: The beaker collecting the sample must be positioned to collect the sample from the dispense location for the selected fluid. The dispense tool must be opened to enable fluid dispense into the beaker.
5. Wait for the fluid to be dispensed into the beaker.

NOTE: After the fluid is dispensed, close the dispense tool.
6. In the **Actual Volume** field, enter the actual volume measured in the beaker to calculate and save the K-Factor for the current fluid.

NOTE: You can press the Cancel softkey to cancel calibration. Calibration will also be cancelled if you leave the Calibrate screen.

Maintenance Screen

The Maintenance screen is used to set the alarm targets for meter volume, valve cycles, and filter calendar days. Each can be reset using the corresponding Reset softkey.

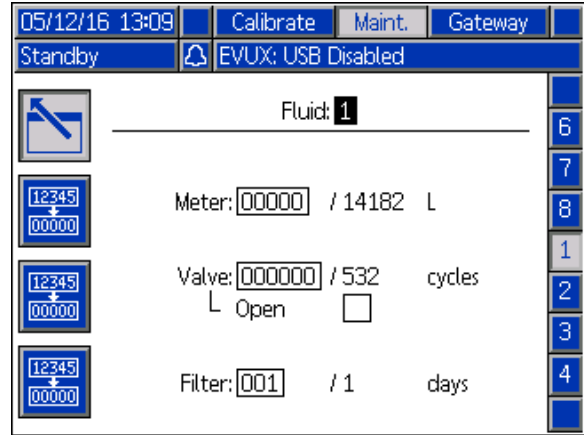

Field	Description
Fluid	Displays the current fluid panel. Enter a number of a different panel or use the up/down arrows to select another fluid panel.
Meter:	Enter the target meter volume. The actual meter volume is displayed to the right of the editable field. <ul style="list-style-type: none"> • Range — 0–99999 • Default — 0
Valve:	Enter the target valve cycle. The actual valve cycles is displayed to the right of the editable field. <ul style="list-style-type: none"> • Range — 0–9999999 • Default — 0 <p>NOTE: Valve operation can be checked manually by toggling the Open check box. The Open check box will be grayed out when not available for editing.</p>
Open:	Select to open the fluid panel valve for maintenance or troubleshooting.
Filter:	Enter the target filter calendar days. The actual calendar days are displayed to the right of the editable field. <ul style="list-style-type: none"> • Range — 0–999 • Default — 0
Numbers on vertical elevator bar	One number for each possible Fluid Panel. Use the up/down arrow keys to navigate, or enter the desired value in the Fluid: field.

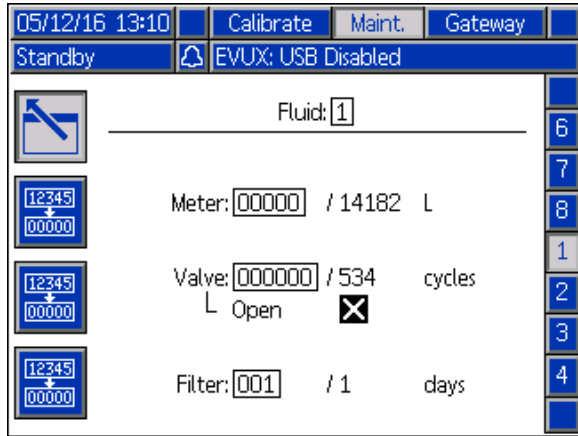

Maintenance Screen — Valve Open and available for editing

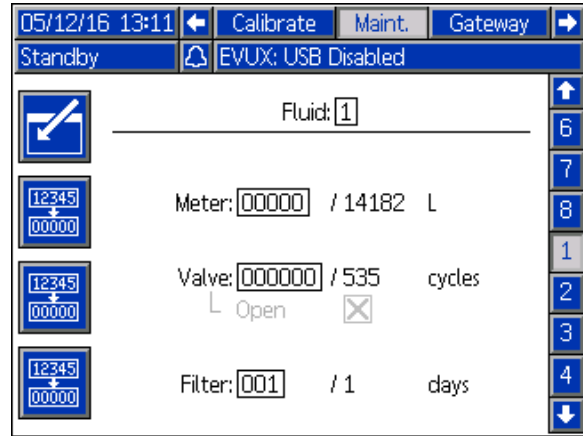

Maintenance Screen — Valve Open and not available for editing

Setup Maintenance Schedule / Parameters

Maintenance schedule values will need to be entered for each installed fluid panel.

NOTE: Parameter values of zero will not generate a maintenance advisory for that parameter.

Set the value that will trigger a maintenance advisory for the flow meter, fluid panel valve, and supply line filter.

The actual value column, shown to the right of the slash (/) displays the current totalizer value. If this value exceeds the set limit, the value will turn red and a maintenance advisory is issued. See [Maintenance Screen, page 107](#) for more information about maintenance totalizers.

After a maintenance value causes an advisory, a new value which is higher than the actual reading must be entered.

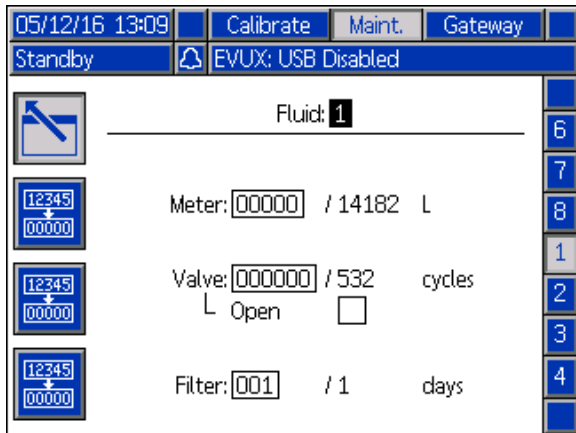

Gateway Screen

If your system has no gateway installed, the following screen displays when the Gateway tab is selected.

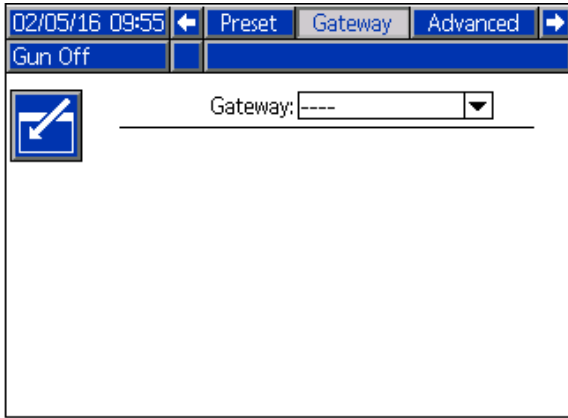

DeviceNet Gateway Screen 1

Use this screen to enter and save DeviceNet configuration information.

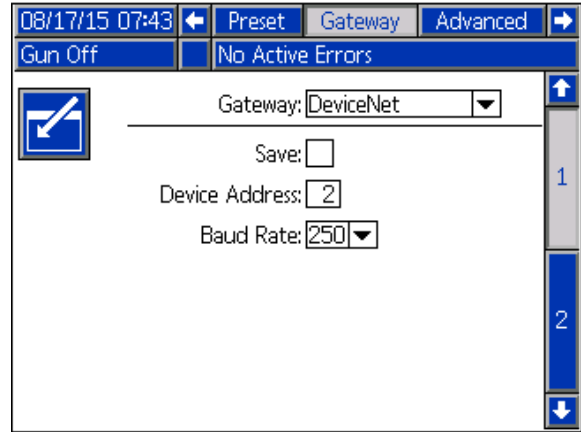

- Enter the address used to identify the device on the DeviceNet network (0-63).
- Select the desired baud rate from the dropdown menu.
 - 125 kbps
 - 250 kbps
 - 500 kbps
- Check the Save box to write the settings to the Gateway. (Wait) displays on the screen to indicate changes are being applied.

DeviceNet Gateway Screen 2

This screen displays the hardware revision number, system serial number, map ID, map name, map revision number, and map install date.

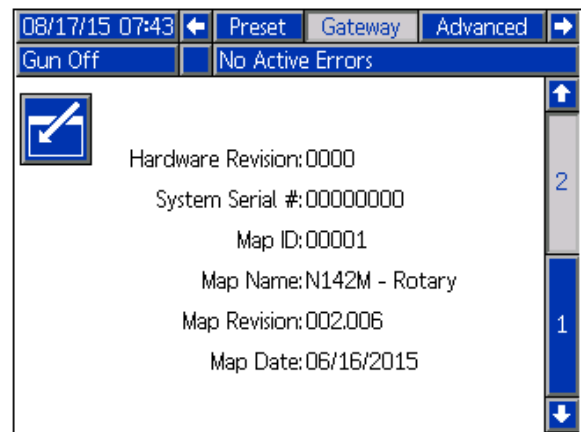

EtherNet/IP Gateway Screen 1

Use this screen to enter and save EtherNet/IP configuration information.

- Enter the DHCP address, the IP address, the subnet mask, the Gateway address, DNS 1, and DNS 2.
- Check the Save box to write the settings to the Gateway.

EtherNet/IP Gateway Screen 2

This screen displays the hardware revision number, system serial number, map ID, map name, map revision number, and map install date.

Modbus TCP Gateway Screen

Use this screen to enter and save Modbus TCP configuration information.

- Make sure the Enable box is unchecked.
- Enter the DHCP address, the IP address, the subnet mask, the Gateway address, DNS 1, and DNS 2.
- Check the Enable box to write the settings to the Gateway.

PROFINET Gateway Screen 1

Use this screen to enter and save PROFINET configuration information.

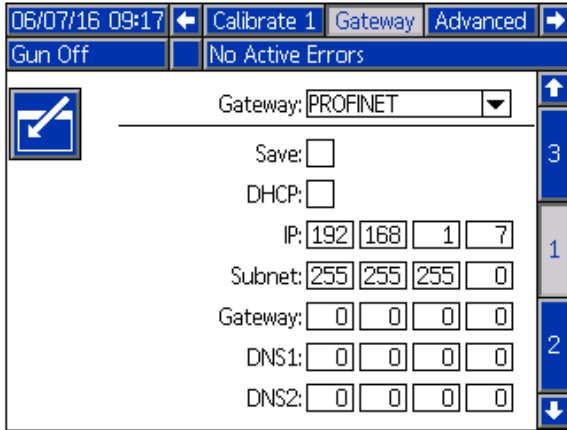

- Enter the DHCP address, the IP address, the subnet mask, the Gateway address, DNS 1, and DNS 2.
- Check the Save box to write the settings to the Gateway.

PROFINET Gateway Screen 2

This screen displays the device address, install date, function tag, and system description.

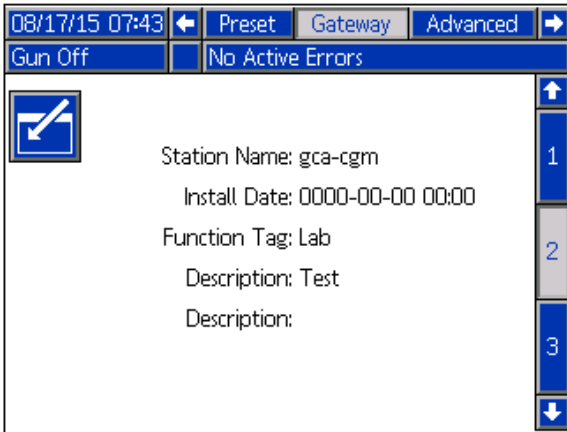

PROFINET Gateway Screen 3

This screen displays the hardware revision number, system serial number, map ID, map name, map revision number, and map install date.

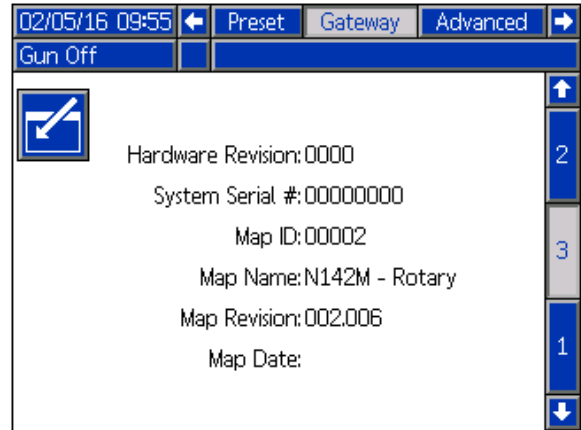

Advanced Screen 1

Advanced screen 1 sets the following display parameters.

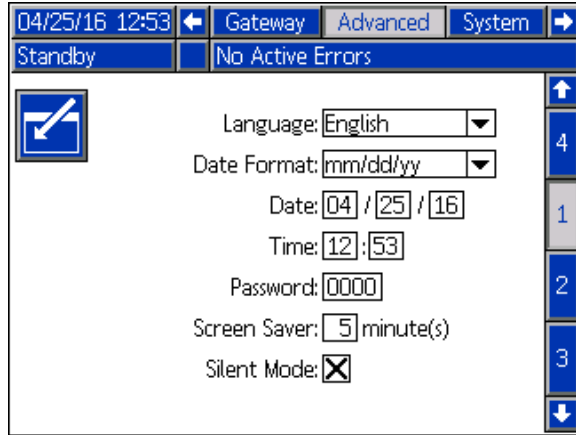

Field	Description
Language:	Define the language all screens will display. Select one of the following. <ul style="list-style-type: none"> • English (default) • Spanish (Spain) • French (France) • German • Japanese • Chinese (Simplified) • Korean • Dutch • Italian • Portuguese (Portugal) • Swedish • Russian
Date Format:	Select mm/dd/yy, dd/mm/yy, or yy/mm/dd.
Date:	Enter the date, using the format selected. Use two digits for the month, day, and year.
Time:	Enter current time in hours (24 hour clock) and minutes. Seconds are not adjustable.
Password:	The password is only used to enter Setup mode. The default is 0000, which means no password is required to enter Setup. If a password is desired, enter a number from 0001 to 9999. NOTE: Be sure to write down the password and keep it in a secure location.
Screen Saver:	Select the desired screen timeout in minutes (00-99). 5 is the default. Select zero (0) to disable the screen saver.
Silent Mode:	Select Silent Mode to disable the alarm buzzer and audible feedback.
Numbers on vertical elevator bar	Represents which Advanced Screen is selected. Use the up/down arrows to move between Advanced screens.

Advanced Screen 2

Advanced screen 2 sets display units (US or metric).

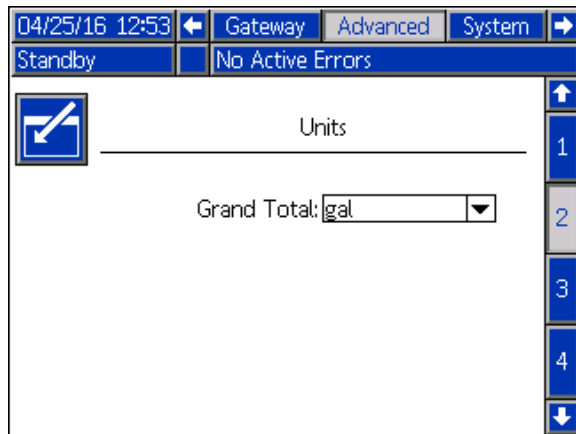

Advanced Screen 3

Advanced screen 3 enables USB downloads and uploads.

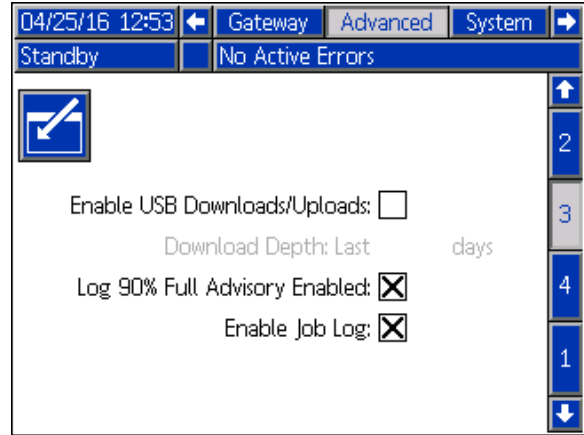

Field	Description
Enable USB Downloads/Uploads:	Select this box to enable USB downloads and uploads. Enabling USB activates the Download Depth field.
Download Depth:	Enter the number of days for which you want to retrieve data. For example, to retrieve data for the previous week, enter 7.
Log 90% Full Advisory Enabled:	Enabled by default. When enabled, the system will issue an advisory if the memory log has reached 90% of capacity. Perform a download to avoid loss of data. NOTE: If memory capacity is reached, the oldest data is lost as new data is generated.
Enable Job Log:	Select this box to enable the job log. NOTE: If job log data exists and this box is deselected, the existing data is retained, but no new data will be generated.

Advanced Screen 4

Advanced screen 4 displays the software part numbers and versions for the system components. This is not an editable screen.

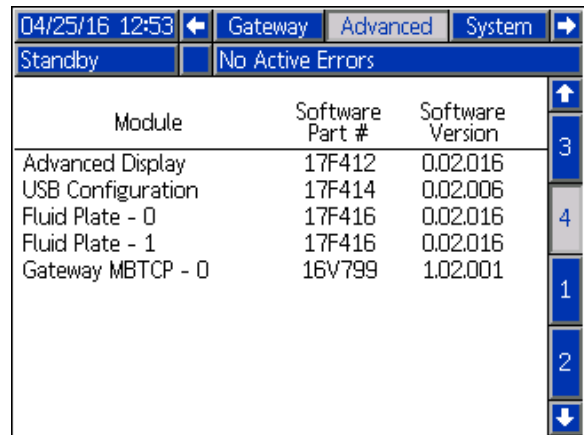

Appendix B - System Design

Power

The finished system is limited to a power level of 100 Watts. When defining how the system will be used, it is important to ensure that power demand at any given moment does not exceed the available power.

Item	Power Requirement
Control Panel with FCM and ADM	25 W
Fluid panel	
26A071	Solenoid – 14.64 W max The power consumption for the meter being supplied by the customer must be added into this value if it will draw power from the ProDispense system.
26A129	Solenoid – 14.64 W max Meter – 0.16 W
26A130	Solenoid – 14.64 W max Meter – 0.16 W
26A131	Solenoid – 5.4 W Meter – 0.16 W
26A132	Solenoid – 5.4 W Meter – 0.16 W
26A165	Solenoid – 5.4 W Meter – 0.16 W
26A247	Solenoid – 5.4 W Meter – 15.6 W
Light Bar Accessory	Negligible
Remote Operator Station	Negligible
FCM	Negligible
CGM	Negligible

System Size

The maximum distance a system can cover is approximately 250 feet from one side to another. This limitation is because of the maximum length of the communication cables used to configure the system.

Appendix C - Communications Gateway Module

Install Fieldbus Connections

Connect cables to fieldbus per fieldbus standards.

PROFINET

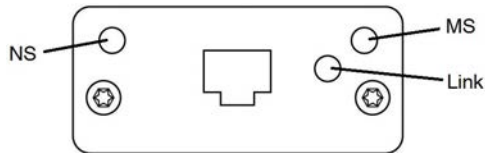

The Ethernet interface operates at 100Mbit, full duplex, as required by PROFINET. The Ethernet interface is auto-polarity sensing and auto-crossover capable.

Network Status (NS)

State	Description	Comments
Off	Offline	<ul style="list-style-type: none"> No power No connection with IO Controller
Green	On-line, (RUN)	<ul style="list-style-type: none"> Connection with IO Controller established IO Controller with RUN state
Flashing Green	On-line, (STOP)	<ul style="list-style-type: none"> Connection with IO Controller established IO Controller in STOP state

Module Status (MS)

State	Description	Comments
Off	Not initialized	No power or module in "SETUP" or "NW_INIT" state
Green	Normal operation	Diagnostic event(s) present
Flashing Green	Initialized, diagnostic event(s) present	Used by engineering tools to identify node on network
Red	Exception error	Module in state "EXCEPTION"
Red (1 flash)	Configuration error	Expected identification differs from Real Identification
Red (2 flashes)	IP Address not set	Set IP address via system monitor or DNS server
Red (3 flashes)	Station Name not set	Set Station Name via system monitor
Red (4 flashes)	Major Internal Error	Cycle system power; replace module

Link/Activity (Link)

State	Description
Off	No Link, no communication present
Green	Link established, no communication present
Green, flashing	Link established, communication present

EtherNet/IP

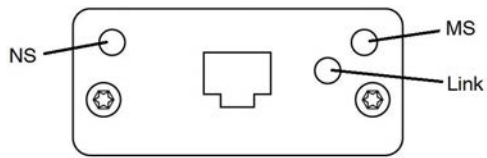

The Ethernet interface operates at 100Mbit, full duplex, as required by PROFINET. The Ethernet interface is auto-polarity sensing and auto-crossover capable.

Network Status (NS)

State	Description
Off	No power or no IP address
Green	On-line, one or more connections established (CIP Class 1 or 3)
Flashing Green	On-line, no connections established
Red	Duplicate IP address, FATAL error
Flashing Red	One or more connections timed out (CIP Class 1 or 3)

Module Status (MS)

State	Description
Off	No power
Green	Controller by a Scanner in Run state
Flashing Green	Not configured, or Scanner in idle state
Red	Major fault (EXCEPTION-state, FATAL error etc.)
Flashing Red	Recoverable fault(s)

Link/Activity (Link)

State	Description
Off	No Link, no activity
Green	Link established
Flashing Green	Activity

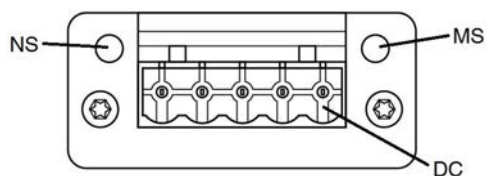
DeviceNet**Network Status (NS)**

State	Description
Off	Not online / No power
Green	On-line, one or more connections are established
Flashing Green (1 Hz)	On-line, no connections established
Red	Critical link failure
Flashing Red (1 Hz)	One or more connections timed-out
Alternating Red/Green	Self test

Module Status (MS)

State	Description
Off	No power or not initialized
Green	Initialized
Flashing Green (1 Hz)	Missing or incomplete configuration, device needs commissioning
Red	Unrecoverable Fault(s)
Flashing Red (1 Hz)	Recoverable fault(s)
Alternating Red/Green	Self test

DeviceNet Connector (DC)

Pin	Signal	Description
1	V-	Negative bus supply voltage
2	CAN_L	CAN low bus line
3	SHIELD	Cable shield
4	CAN_H	CAN high bus line
5	V+	Positive bus supply voltage

Modbus TCP

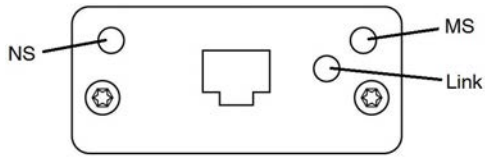

The Ethernet interface supports 10/100 Mbit, full or half duplex operation.

Network Status (NS)

State	Description
Off	No power or no IP address
Green	Connection established. Module is in the Process Active state or the Idle state.
Flashing Green	Waiting for connection
Red	Duplicate IP address or FATAL error
Flashing Red	Process Active timeout

Module Status (MS)

State	Description
Off	No power
Green	No operation
Red	Major fault. The module is in the state of EXCEPTION (or FATAL event)
Flashing Red	Minor fault in diagnostic object or IP conflict
Flashing Red (3 flashes, pause, repeat)	The host of the mapped property is not responding. <ul style="list-style-type: none"> • Check whether all system devices are powered on. • Check cabling between all system devices
Flashing Red (4 flashes, pause, repeat)	The host device (ADM) has not initiated property mapping <ul style="list-style-type: none"> • Disable and then re-enable the module from the ADM
Flashing Red (5 flashes, pause, repeat)	The module is not connected <ul style="list-style-type: none"> • Verify that the module is connected
	The system has an invalid network configuration <ul style="list-style-type: none"> • Ensure proper network configuration

Link/Activity (Link)

State	Description
Off	No Link, no communication present
Green	Link established, no communication present
Flashing Green	Link established, communication present

CGM I/O Data Map

All variables are little-endian 32-bit (long word) unsigned integers. The order is presented in high-byte/low-byte order during data transfer.

Automation Inputs (signals from ProDispense via Ethernet/IP, PROFINET, DeviceNet)

Byte	Description	Zone
0	Current System State	System
	0 = Uninitialized 1 = Standby Off 2 = Standby On 3 = Dispensing >3 = not valid	
4	Current Recipe	System
	0 = no recipe active 1-50 = recipe number >50 = not valid	
8	Current Job Number	System
	System-assigned job number	
12	Fluid Panel State	Fluid 1
16	Fluid Panel State	Fluid 2
20	Fluid Panel State	Fluid 3
24	Fluid Panel State	Fluid 4
28	Fluid Panel State	Fluid 5
32	Fluid Panel State	Fluid 6
36	Fluid Panel State	Fluid 7
40	Fluid Panel State	Fluid 8
44	Current Job Volume	Fluid 1
48	Current Job Volume	Fluid 2
52	Current Job Volume	Fluid 3
56	Current Job Volume	Fluid 4
60	Current Job Volume	Fluid 5
64	Current Job Volume	Fluid 6
68	Current Job Volume	Fluid 7
72	Current Job Volume	Fluid 8
	Values (in cc) apply for each Fluid Panel (value is represented with the last 2 digits being hundredths of a cc) For example, a value of 1250 = 12.50 cc	
76	Fluid Panel Event Raised	Fluid 1-8
	0 = Fluid Panel 1 1 = Fluid Panel 2 2 = Fluid Panel 3 3 = Fluid Panel 4 4 = Fluid Panel 5 5 = Fluid Panel 6 6 = Fluid Panel 7 7 = Fluid Panel 8 >7 = not valid	

Appendix C - Communications Gateway Module

Byte	Description		Zone
80	Displayed Event	Values apply for each Fluid Panel 0 = Communication Error 1 = General Fluid Panel Error 2 = Hardware Dispense Valve Error 3 = Hardware Flow Meter Error 4 = Hardware Regulator Error 5 = Hardware Operator Station Error 6 = Dispense No Flow 7 = Dispense Timeout 8 = Dispense Tolerance 9 = System Fluid Leak 10 = Advisory Job Rollover 11 = Advisory Grand Total Rollover >11 = not valid	System
Command interface			
84	Command Status	0 = NOP (default state, ready for command processing) 1 = Busy (current command being processed; no new incoming commands accepted) 2 = Ack (command successfully processed) 3 = Nak* 4 = Error* NOTE: Nak or Error indicates unsuccessful command processing. Possible issues: <ul style="list-style-type: none"> • Wrong command • Wrong command arguments *System is ready for command processing	System
88	Command Return 1	Values in these bytes depend on the command that was received. For information regarding the values, see the Command Structures, page 129 section and locate the command that was sent to determine the expected responses.	System
92	Command Return 2		System
96	Command Return 3		System
100	Command Return 4		System
104	Command Return 5		System
108	Command Return 6		System
112	Command Return 7		System
116	Command Return 8		System
120	Command Return 9		System
124	Command Return 10		System
128	Command Return 11		System
132	Command Return 12		System
136	Command Return 13		System
140	Command Return 14		System
144	Command Return 15		System

Automation Outputs (signals to ProDispense via Ethernet/IP, PROFINET, DeviceNet)

Byte	Description	Zone	
0	Set Current Recipe	0 = no recipe active 1-50 = recipe number >50 = not valid	System
4	Set System State	0 = Uninitialized 1 = Standby Off 2 = Standby On 3 = Dispense >3 = not valid	System
8	Set Job Number	User-assigned job number	System
Command interface			
12	Command Argument 1	Instructions to the ProDispense from the Automation (PLC) source. The number of arguments required vary by type of command being sent. The available commands are listed in byte 72 below.	System
16	Command Argument 2		System
20	Command Argument 3		System
24	Command Argument 4		System
28	Command Argument 5		System
32	Command Argument 6		System
36	Command Argument 7		System
40	Command Argument 8		System
44	Command Argument 9		System
48	Command Argument 10		System
52	Command Argument 11		System
56	Command Argument 12		System
60	Command Argument 13		System
64	Command Argument 14		System
68	Command Argument 15		System
72	Command ID	0 = NOP 1 = Write user ID (5 arguments) 2 = Write recipe (8 arguments) 3 = Write fluid panel command (5 arguments) 4 = Write fluid panel configuration (12 arguments) 100 = Read user ID (2 arguments) 101 = Read recipe (2 arguments) 102 = Read job record (1 argument) 103 = Read event record (1 argument) 104 = Read fluid panel status (1 argument) 105 = Read fluid panel configuration (1 argument) NOTE: See Command Process, page 128 for how to present arguments and what information is returned.	System

Automation Inputs (signals from ProDispense via Modbus TCP)

Register	Description		Zone
40100	Current System State	0 = Uninitialized 1 = Standby Off 2 = Standby On 3 = Dispensing >3 = not valid	System
40102	Current Recipe	0 = no recipe active 1-50 = recipe number >50 = not valid	System
40104	Current Job Number	System-assigned job number	System
40106	Fluid Panel State	Values apply for each Fluid Panel 0 = Uninitialized 1 = Disabled 2 = Offline 3 = Standby Off 4 = Standby On 5 = Dispensing 6 = Pausing >6 = reserved	Fluid 1
40108	Fluid Panel State		Fluid 2
40110	Fluid Panel State		Fluid 3
40112	Fluid Panel State		Fluid 4
40114	Fluid Panel State		Fluid 5
40116	Fluid Panel State		Fluid 6
40118	Fluid Panel State		Fluid 7
40120	Fluid Panel State		Fluid 8
40122	Fluid Panel Status	Register number shown for each fluid has bits with assigned purpose; next sequential register is not used Values apply for each Fluid Panel Bit Definitions: 0 = Flow meter enabled 1 = Flow meter volume reset 2 = Valve state (0=off, 1=on) 3 = Valve triggered 4 = Dispense pause 5 = Dispense top off 6 = Dispense complete 7 = Job complete 8-15 unused	Fluid 1
40124	Fluid Panel Status		Fluid 2
40126	Fluid Panel Status		Fluid 3
40128	Fluid Panel Status		Fluid 4
40130	Fluid Panel Status		Fluid 5
40132	Fluid Panel Status		Fluid 6
40134	Fluid Panel Status		Fluid 7
40136	Fluid Panel Status		Fluid 8

Register	Description		Zone
40138	Fluid Panel Events	Register number shown for each fluid has bits with assigned purpose; next sequential register is not used Values apply for each Fluid Panel Bit Definitions: 0 = Communication error 1 = General fluid panel error 2 = Hardware dispense valve error 3 = Hardware flow meter error 4 = Hardware regulator error 5 = Hardware operator station error 6 = Dispense no flow 7 = Dispense timeout 8 = Dispense tolerance 9 = System fluid leak 10 = Advisory job rollover 11 = Advisory grand total rollover 12-15 = unused	Fluid 1
40140	Fluid Panel Events		Fluid 2
40142	Fluid Panel Events		Fluid 3
40144	Fluid Panel Events		Fluid 4
40146	Fluid Panel Events		Fluid 5
40148	Fluid Panel Events		Fluid 6
40150	Fluid Panel Events		Fluid 7
40152	Fluid Panel Events		Fluid 8
40154	Current Job Volume	Values (in cc) apply for each Fluid Panel (value is represented with the last 2 digits being hundredths of a cc) For example, a value of 1250 = 12.50 cc	Fluid 1
40156	Current Job Volume		Fluid 2
40158	Current Job Volume		Fluid 3
40160	Current Job Volume		Fluid 4
40162	Current Job Volume		Fluid 5
40164	Current Job Volume		Fluid 6
40166	Current Job Volume		Fluid 7
40168	Current Job Volume		Fluid 8
40170	Last Job Volume	Values (in cc) apply for each Fluid Panel (value is represented with the last 2 digits being hundredths of a cc) For example, a value of 1250 = 12.50 cc	Fluid 1
40172	Last Job Volume		Fluid 2
40174	Last Job Volume		Fluid 3
40176	Last Job Volume		Fluid 4
40178	Last Job Volume		Fluid 5
40180	Last Job Volume		Fluid 6
40182	Last Job Volume		Fluid 7
40184	Last Job Volume		Fluid 8
40186	Current Flow	Flow in cc/min. Value has fixed-point value with the lower 10 digits being the value to the right of the decimal point. To obtain the integer value, ignore the lowest 10 digits. Values apply for each Fluid Panel	Fluid 1
40188	Current Flow		Fluid 2
40190	Current Flow		Fluid 3
40192	Current Flow		Fluid 4
40194	Current Flow		Fluid 5
40196	Current Flow		Fluid 6
40198	Current Flow		Fluid 7
40200	Current Flow		Fluid 8

Appendix C - Communications Gateway Module

Register	Description		Zone
40202	Dispense Target	Values (in cc) apply for each Fluid Panel (value is represented with the last 2 digits being hundredths of a cc) For example, a value of 1250 = 12.50 cc	Fluid 1
40204	Dispense Target		Fluid 2
40206	Dispense Target		Fluid 3
40208	Dispense Target		Fluid 4
40210	Dispense Target		Fluid 5
40212	Dispense Target		Fluid 6
40214	Dispense Target		Fluid 7
40216	Dispense Target		Fluid 8
40218	Dispense Tolerance	Values (in percent) apply for each Fluid Panel For example, a value of 12 = 12%	Fluid 1
40220	Dispense Tolerance		Fluid 2
40222	Dispense Tolerance		Fluid 3
40224	Dispense Tolerance		Fluid 4
40226	Dispense Tolerance		Fluid 5
40228	Dispense Tolerance		Fluid 6
40230	Dispense Tolerance		Fluid 7
40232	Dispense Tolerance		Fluid 8
40234	Grand Total Volume	Values (in cc) apply for each Fluid Panel	Fluid 1
40236	Grand Total Volume		Fluid 2
40238	Grand Total Volume		Fluid 3
40240	Grand Total Volume		Fluid 4
40242	Grand Total Volume		Fluid 5
40244	Grand Total Volume		Fluid 6
40246	Grand Total Volume		Fluid 7
40248	Grand Total Volume		Fluid 8
40250	Fluid Panel Event Raised	Register number 40250 has bits with assigned purpose; register 40251 is not used. A fluid panel event is indicated by a value of 1 in the bit position attributed to the applicable fluid panel. NOTE: It is possible for multiple panels to have an event indicated. Bit Definition: 0 = Fluid Panel 1 1 = Fluid Panel 2 2 = Fluid Panel 3 3 = Fluid Panel 4 4 = Fluid Panel 5 5 = Fluid Panel 6 6 = Fluid Panel 7 7 = Fluid Panel 8 8-15 unused	System
40252	Displayed Event		System

Register	Description		Zone
Command interface			
40900	Command Status	0 = NOP (default state, ready for command processing) 1 = Busy (current command being processed; no new incoming commands accepted) 2 = Ack (command successfully processed) 3 = Nak* 4 = Error* NOTE: Nak or Error indicates unsuccessful command processing. Possible issues: <ul style="list-style-type: none"> • Wrong command • Wrong command arguments *System is ready for command processing	System
40902	Command Return 1	Values in these registers depend on the command that was received. For information regarding the values, see the Command Structures, page 129 section and locate the command that was sent to determine the expected responses.	System
40904	Command Return 2		System
40906	Command Return 3		System
40908	Command Return 4		System
40910	Command Return 5		System
40912	Command Return 6		System
40914	Command Return 7		System
40916	Command Return 8		System
40918	Command Return 9		System
40920	Command Return 10		System
40922	Command Return 11		System
40924	Command Return 12		System
40926	Command Return 13		System
40928	Command Return 14		System
40930	Command Return 15		System

Automation Outputs (signals to ProDispense via Modbus TCP)

Register	Description		Zone
40400	Set Current Recipe	0 = no recipe active, reset fluid panel presets 1-50 = recipe number >50 = not valid	System
40402	Set System State	0 = Uninitialized 1 = Standby Off 2 = Standby On 3 = Dispense >3 = not valid	System

Appendix C - Communications Gateway Module

Register	Description		Zone
40404	Set Job Number	User-assigned job number to be used with the current job Range allowed = 0-99999	System
40406	Grand Total Units		System
40408	Number of Fluid Panels	Define the number of installed fluid panels 1-8 = Quantity installed >8 = not valid	System
40410	Fluid Panel Enabled	Values apply for each Fluid Panel 0 = Not enabled 1 = Enabled >1 not valid	Fluid 1
40412	Fluid Panel Enabled		Fluid 2
40414	Fluid Panel Enabled		Fluid 3
40416	Fluid Panel Enabled		Fluid 4
40418	Fluid Panel Enabled		Fluid 5
40420	Fluid Panel Enabled		Fluid 6
40422	Fluid Panel Enabled		Fluid 7
40424	Fluid Panel Enabled		Fluid 8
40426	Fluid Panel Job Units		Values apply for each Fluid Panel 0 = cc 1 = L 2 = oz 3 = gal >3 = not valid
40428	Fluid Panel Job Units	Fluid 2	
40430	Fluid Panel Job Units	Fluid 3	
40432	Fluid Panel Job Units	Fluid 4	
40434	Fluid Panel Job Units	Fluid 5	
40436	Fluid Panel Job Units	Fluid 6	
40438	Fluid Panel Job Units	Fluid 7	
40440	Fluid Panel Job Units	Fluid 8	
Command interface			
40800	Command Argument 1	Instructions to the ProDispense from the Automation (PLC) source. The number of arguments required vary by type of command being sent. The available commands are listed in register 40830 below.	System
40802	Command Argument 2		System
40804	Command Argument 3		System
40806	Command Argument 4		System
40808	Command Argument 5		System
40810	Command Argument 6		System
40812	Command Argument 7		System
40814	Command Argument 8		System
40816	Command Argument 9		System
40818	Command Argument 10		System
40820	Command Argument 11		System
40822	Command Argument 12		System
40824	Command Argument 13		System
40826	Command Argument 14		System

Register	Description		Zone
40828	Command Argument 15		System
40830	Command ID	0 = NOP 1 = Write user ID (5 arguments) 2 = Write recipe (8 arguments) 3 = Write fluid panel command (5 arguments) 4 = Write fluid panel configuration (12 arguments) 100 = Read user ID (2 arguments) 101 = Read recipe (2 arguments) 102 = Read job record (1 argument) 103 = Read event record (1 argument) 104 = Read fluid panel status (1 argument) 105 = Read fluid panel configuration (1 argument) NOTE: See Command Process, page 128 for how to present arguments and what information is returned.	System

Commands

All parameters specified in the commands are 32 bit (long word) unsigned integer values.

Command Process

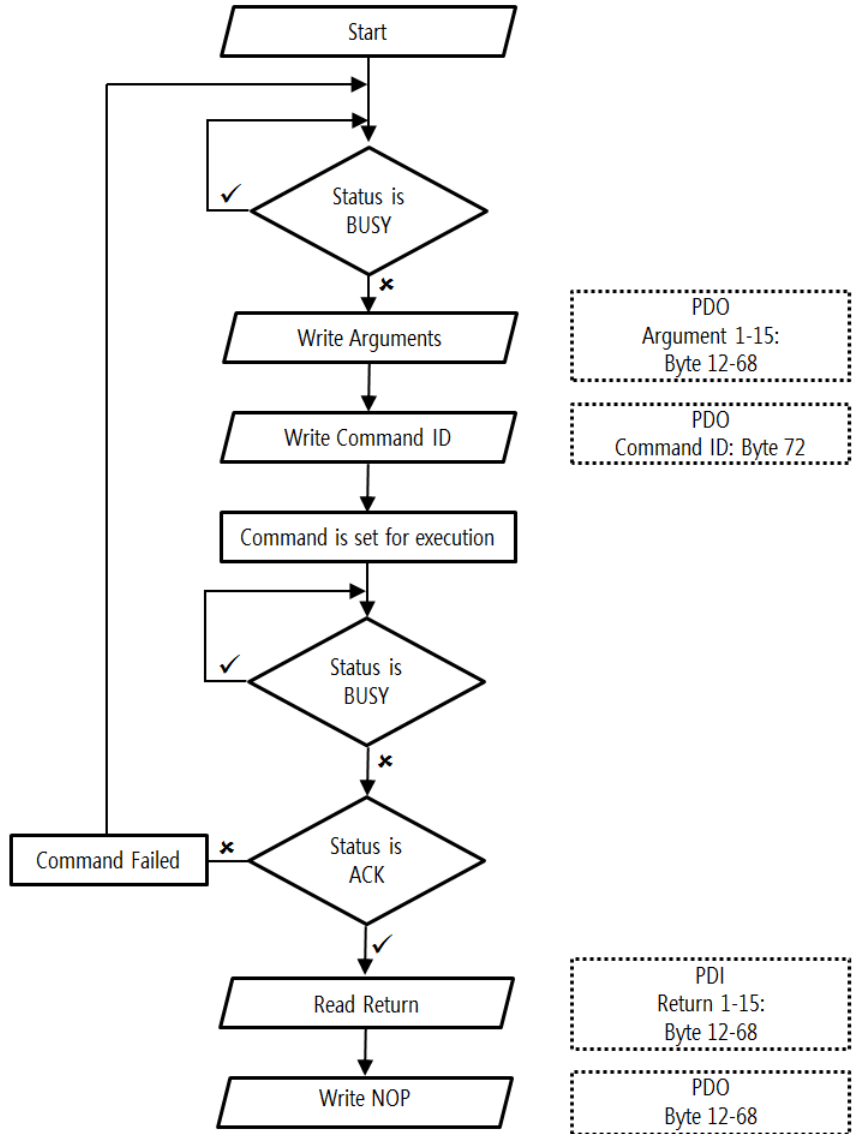

Using the flowchart:

The ProDispense makes status information available to the Automation source on a continuous basis. The information contained in the bytes of the message stream (for non-Modbus TCP) or in the registers (Modbus TCP). To determine whether that information is usable, the Automation source must monitor the command status (byte 84 for non-Modbus TCP CGMs or register 40900 for Modbus CGM). Commands to the ProDispense will only be accepted

if the command status is in the NOP, Nak, or Error state.

1. Monitor the Command Status (byte 84 or register 40900) value provided by the ProDispense system. When the Command Status value is 0, 2, 3, or 4, a new command can be sent to the ProDispense system.
2. Create the arguments for the new command and place them in bytes 12–68 or registers 40800–40828. To determine the needed arguments, see [Command Structures, page 129](#).

3. Create the Command ID in byte 72 or register 40830.
4. Send the command to the ProDispense system and monitor the Command Status value. Any value except 1 (Busy) means the command was processed. Refer to byte 84 or register 40900 to determine whether the command completed successfully.
5. **If the Command Status equals a 2 (Ack):**
 - a. The responses to the command are now available for viewing in bytes 88–144 or registers 40902–40930. For the meanings of those responses, refer to the table for the command that was sent in [Command Structures, page 129](#).
 - b. Create a new command with a Command ID of 0 (NOP) and send to the ProDispense.
6. **If the Command Status equals a 3 (Nak):** Examine the information provided with the last command to determine whether one or more arguments were not configured correctly. After correcting the arguments, go to step 3 above.
7. **If the Command Status equals a 4 (Error):**
 - a. Ensure that the arguments not necessary for the command were empty.
 - b. After correcting the arguments, go to step 3 above.

Command Structures

There are two types of commands, write and read. A write command is used to assign values to ProDispense system settings or components. A read command is used to obtain current information about the ProDispense system and its individual components.

NOTE: A write command will overwrite existing conditions. Perform a read first to determine if the current settings need to be retained.

Available write commands:

- Write User ID (only 1 fluid panel at a time can be written)
- Write Recipe (only 1 recipe at a time can be written)
- Write Fluid Panel (only 1 fluid panel at a time can be written)
- Write Fluid Panel Configuration (only 1 fluid panel at a time can be written)

Available read commands:

- Read User ID
- Read Recipe
- Read Job Record
- Read Event Record
- Read Fluid Panel Status
- Read Fluid Panel Configuration

Write User ID

Parameter	Description	Value Range
Command ID	Write User ID	1
Argument 1	Fluid Panel Number	1 = Fluid panel 1 2 = Fluid panel 2 . . . 8 = Fluid panel 8
Argument 2	ID Field NOTE: If more than 1 ID field is desired for a single fluid panel, a new write command will be necessary for each ID	0 = User ID 1 = Job ID 1 2 = Job ID 2 3 = Job ID 3
Argument 3	ID characters 3-0	Ascii characters
Argument 4	ID characters 7-4	Ascii characters
Argument 5	ID characters 9-8	Ascii characters
Return 1	Fluid Panel Number	1-8
Return 2	ID Field	0 = User ID 1 = Job ID 1 2 = Job ID 2 3 = Job ID 3
Return 3	ID characters 3-0	Ascii characters
Return 4	ID characters 7-4	Ascii characters
Return 5	ID characters 9-8	Ascii characters

Write Recipe

This command will only populate one row of a recipe. It may be necessary to send up to 11 commands to fully define the recipe and enable it for use.

Parameter	Description	Value Range
Command ID	Write Recipe	2
Argument 1	Recipe Number	1–50
Argument 2	Batch Number NOTE: If an existing recipe is overwritten and one row already exists in the recipe and it is not overwritten prior to enabling the recipe, an error may occur due to duplication.	0 = Use Argument 3 1–10 = These correspond with the # column of the recipe screen.
Argument 3	Enable/Disable Recipe NOTE: Only used if Argument 2 = 0	0 = Disable 1 = Enable
Argument 4	Fluid Number	1–8
Argument 5	Target (in sec or cc)	1–268435456
Argument 6	Tolerance (%)	0–99
Argument 7	Timeout (ms)	0–4294967296
Argument 8	Order (fluid sequence) NOTE: Fluids with the same order number will occur simultaneously.)	0 = Interpret Argument 5 as being sec. 1–10
Return 1	Recipe Number	1–8
Return 2	Batch Number	1–268435456
Return 3	Enable/Disable Recipe (Valid if Batch = 0)	0 = Disable 1 = Enable
Return 4	Fluid Number	1–8
Return 5	Target (in sec or cc)	1–268435456
Return 6	Tolerance (%)	0–99
Return 7	Timeout (ms)	0–4294967296
Return 8	Order	0 = Interpret Return 5 as being sec. 1–10

Write Fluid Panel

Parameter	Description	Value Range
Command ID	Write Fluid Panel	3
Argument 1	Fluid Panel Number	1-8
Argument 2	Fluid Panel Command	0 = Off 1 = Standby On 2 = Dispense 3 = Pause / Resume
Argument 3	Target (in cc)	0-268435456
Argument 4	Tolerance (%)	0-99
Argument 5	Timeout (ms)	0-4294967296
Return 1	Fluid Panel Number	1-8
Return 2	State	0 = Uninitialized 1 = Disabled 2 = Offline 3 = Off 4 = Standby On 5 = Dispense 6 = Pause
Return 3	Valve State	0 = Closed 1 = Open
Return 4	Job Volume (in 0.1 cc)	0-268435456
Return 5	Flow Rate (in cc/min)	0-4194304
Return 6	Last Job Volume (in 0.1 cc)	0-268435456
Return 7	Meter Grand Total (in cc)	0-4294967296
Return 8	Job Events	Bit Assignment (0=no event) 0 = Communication error 1 = General error 2 = Valve error 3 = Flow meter error 4 = Regulator error 5 = Operation status error 6 = No flow 7 = Timeout 8 = Tolerance 9 = Leak 10 = Job rollover 11 = Grand rollover All other bits reserved

Write Fluid Panel Configuration

Parameter	Description	Value Range
Command ID	Write Fluid Panel Configuration	4
Argument 1	Fluid Panel Number	1 = Fluid panel 1 2 = Fluid panel 2 3 = Fluid panel 3 4 = Fluid panel 4 5 = Fluid panel 5 6 = Fluid panel 6 7 = Fluid panel 7 8 = Fluid panel 8
Argument 2	Target (in cc)	1-268435456
Argument 3	Tolerance (%)	0-99
Argument 4	Timeout (in ms)	0-4294967296
Argument 5	Top Off Time (in ms)	0-4294967296
Argument 6	K-Factor (in 0.001)	1-999999
Argument 7	Leak Rate (in 0.1 cc/min)	0-268435456
Argument 8	Settling Time (in ms)	0-99999
Argument 9	Auto Adjust Enable	0 = Disable 1 = Enable
Argument 10	Auto Adjust Time (in ms)	0-10000
Argument 11	Op Station Mode	0 = Station 1 = Recipe
Argument 12	Op Station Stop Function	0 = Standby 1 = Pause 2 = Pause - Standby
Return 1	Fluid Panel Number	1- 8
Return 2	Target (in cc)	1-268435456
Return 3	Tolerance (%)	0-99
Return 4	Timeout (in ms)	0-4294967296
Return 5	Top Off Time (in ms)	0-4294967296
Return 6	K-Factor (in 0.001)	1-999999
Return 7	Leak Rate (in 0.1 cc/min)	0-268435456
Return 8	Settling Time (in ms)	0-99999
Return 9	Auto Adjust Enable	0 = Disable 1 = Enable
Return 10	Auto Adjust Time (in ms)	0-10000
Return 11	Op Station Mode	0 = Station 1 = Recipe
Return 12	Op Station Stop Function	0 = Standby 1 = Pause 2 = Pause - Standby

Read User ID

Parameter	Description	Value Range
Command ID	Read User ID	100
Argument 1	Fluid Panel Number	1 = Fluid panel 1 2 = Fluid panel 2 3 = Fluid panel 3 4 = Fluid panel 4 5 = Fluid panel 5 6 = Fluid panel 6 7 = Fluid panel 7 8 = Fluid panel 8
Argument 2	ID Field NOTE: If more than 1 ID field is desired for a single fluid panel, a new write command will be necessary for each ID	0 = User ID 1 = Job ID 1 2 = Job ID 2 3 = Job ID 3
Return 1	Fluid Panel Number	1–8
Return 2	ID Field	0 = User ID 1 = Job ID 1 2 = Job ID 2 3 = Job ID 3
Return 3	ID characters 3–0	Ascii characters
Return 4	ID characters 7–4	Ascii characters
Return 5	ID characters 9–8	Ascii characters

Read Recipe

This command will only read one row of a recipe. It may be necessary to send up to 11 commands to fully read the recipe and determine if it is enabled for use.

Parameter	Description	Value Range
Command ID	Read Recipe	101
Argument 1	Recipe Number	1-50
Argument 2	Batch Number	0 = Display Enable/Disable Recipe value 1-10 = These correspond with the # column of the recipe screen.
Return 1	Recipe Number	1-8
Return 2	Batch Number	0 = Return 3 has valid data 1-10
Return 3	Enable/Disable Recipe (Valid if Batch = 0)	0 = Disable 1 = Enable
Return 4	Fluid Number	0 = Timer 1-8 = Fluid number
Return 5	Target (in sec or cc)	1-268435456
Return 6	Tolerance (%) NOTE: Data not valid if Return 2 = 0	0-99
Return 7	Timeout (ms) NOTE: Data not valid if Return 2 = 0	0-4294967296
Return 8	Order	0-10

Read Job Record

Parameter	Description	Value Range
Command ID	Read Event Record	102
Argument 1	Record Index	≥ 0
Return 1	Date	—
Return 2	Time	—
Return 3	Job Number	0–99999
Return 4	Recipe Number	0–50
Return 5	Fluid Panel	1–8
Return 6	Target Volume	—
Return 7	Actual Volume	—
Return 8	ID characters 3–0	Ascii characters
Return 9	ID characters 7–4	Ascii characters
Return 10	ID characters 9–8	Ascii characters

Read Event Record

Parameter	Description	Value Range
Command ID	Read Event Record	103
Argument 1	Record Index	≥ 0
Return 1	Date	
Return 2	Time	
Return 3	Event Code characters (0:3)	Ascii
Return 4	Event Type	0 = Record 1 = Advisory 2 = Deviation 3 = Alarm
Return 5	Event Action	0 = Set 1 = Acknowledge 2 = Clear

Read Fluid Panel Status

Parameter	Description	Value Range
Command ID	Read Fluid Panel	3
Argument 1	Fluid Panel Number	1-8
Return 1	Fluid Panel Number	1-8
Return 2	State	0 = Uninitialized 1 = Disabled 2 = Offline 3 = Off 4 = Standby On 5 = Dispense 6 = Pause
Return 3	Valve State	0 = Closed 1 = Open
Return 4	Job Volume (in 0.1 cc)	0-268435456
Return 5	Flow Rate (in 0.01 cc/min)	0-4194304
Return 6	Last Job Volume (in 0.1 cc)	0-268435456
Return 7	Meter Grand Total (in cc)	0-4294967296
Return 8	Job Events	Bit Assignment (0=no event) 0 = Communication error 1 = General error 2 = Valve error 3 = Flow meter error 4 = Regulator error 5 = Operation status error 6 = No flow 7 = Timeout 8 = Tolerance 9 = Leak 10 = Job rollover 11 = Grand rollover All other bits reserved

Read Fluid Panel Configuration

Parameter	Description	Value Range
Command ID	Read Fluid Panel Configuration	105
Argument 1	Fluid Panel Number	1–8
Return 1	Fluid Panel Number	1– 8
Return 2	Target (in cc)	1–268435456
Return 3	Tolerance (%)	0–99
Return 4	Timeout (in ms)	0–4294967296
Return 5	Top Off Time (in ms)	0–4294967296
Return 6	K-Factor (in 0.001)	1–999999
Return 7	Leak Rate (in 0.1 cc/min)	0–268435456
Return 8	Settling Time (in ms)	0–99999
Return 9	Auto Adjust Enable	0 = Disable 1 = Enable
Return 10	Auto Adjust Time (in ms)	0–10000
Return 11	Op Station Mode	0 = Station 1 = Recipe
Return 12	Op Station Stop Function	0 = Standby 1 = Pause 2 = Pause – Standby

Graco Standard Warranty

Graco warrants all equipment referenced in this document which is manufactured by Graco and bearing its name to be free from defects in material and workmanship on the date of sale to the original purchaser for use. With the exception of any special, extended, or limited warranty published by Graco, Graco will, for a period of twelve months from the date of sale, repair or replace any part of the equipment determined by Graco to be defective. This warranty applies only when the equipment is installed, operated and maintained in accordance with Graco's written recommendations.

This warranty does not cover, and Graco shall not be liable for general wear and tear, or any malfunction, damage or wear caused by faulty installation, misapplication, abrasion, corrosion, inadequate or improper maintenance, negligence, accident, tampering, or substitution of non-Graco component parts. Nor shall Graco be liable for malfunction, damage or wear caused by the incompatibility of Graco equipment with structures, accessories, equipment or materials not supplied by Graco, or the improper design, manufacture, installation, operation or maintenance of structures, accessories, equipment or materials not supplied by Graco.

This warranty is conditioned upon the prepaid return of the equipment claimed to be defective to an authorized Graco distributor for verification of the claimed defect. If the claimed defect is verified, Graco will repair or replace free of charge any defective parts. The equipment will be returned to the original purchaser transportation prepaid. If inspection of the equipment does not disclose any defect in material or workmanship, repairs will be made at a reasonable charge, which charges may include the costs of parts, labor, and transportation.

THIS WARRANTY IS EXCLUSIVE, AND IS IN LIEU OF ANY OTHER WARRANTIES, EXPRESS OR IMPLIED, INCLUDING BUT NOT LIMITED TO WARRANTY OF MERCHANTABILITY OR WARRANTY OF FITNESS FOR A PARTICULAR PURPOSE.

Graco's sole obligation and buyer's sole remedy for any breach of warranty shall be as set forth above. The buyer agrees that no other remedy (including, but not limited to, incidental or consequential damages for lost profits, lost sales, injury to person or property, or any other incidental or consequential loss) shall be available. Any action for breach of warranty must be brought within two (2) years of the date of sale.

GRACO MAKES NO WARRANTY, AND DISCLAIMS ALL IMPLIED WARRANTIES OF MERCHANTABILITY AND FITNESS FOR A PARTICULAR PURPOSE, IN CONNECTION WITH ACCESSORIES, EQUIPMENT, MATERIALS OR COMPONENTS SOLD BUT NOT MANUFACTURED BY GRACO. These items sold, but not manufactured by Graco (such as electric motors, switches, hose, etc.), are subject to the warranty, if any, of their manufacturer. Graco will provide purchaser with reasonable assistance in making any claim for breach of these warranties.

In no event will Graco be liable for indirect, incidental, special or consequential damages resulting from Graco supplying equipment hereunder, or the furnishing, performance, or use of any products or other goods sold hereto, whether due to a breach of contract, breach of warranty, the negligence of Graco, or otherwise.

FOR GRACO CANADA CUSTOMERS

The Parties acknowledge that they have required that the present document, as well as all documents, notices and legal proceedings entered into, given or instituted pursuant hereto or relating directly or indirectly hereto, be drawn up in English. Les parties reconnaissent avoir convenu que la rédaction du présente document sera en Anglais, ainsi que tous documents, avis et procédures judiciaires exécutés, donnés ou intentés, à la suite de ou en rapport, directement ou indirectement, avec les procédures concernées.

Graco Information

For the latest information about Graco products, visit www.graco.com.

To place an order, contact your Graco Distributor or call to identify the nearest distributor.

Phone: 612-623-6921 **or Toll Free:** 1-800-328-0211 **Fax:** 612-378-3505

All written and visual data contained in this document reflects the latest product information available at the time of publication.

Graco reserves the right to make changes at any time without notice.

For patent information, see www.graco.com/patents.

Original Instructions. This manual contains English. MM 3A3469

Graco Headquarters: Minneapolis

International Offices: Belgium, China, Japan, Korea

GRACO INC. AND SUBSIDIARIES • P.O. BOX 1441 • MINNEAPOLIS MN 55440-1441 • USA

Copyright 2015, Graco Inc. All Graco manufacturing locations are registered to ISO 9001.

www.graco.com
Revision F, 2/2020