

INSTALLATION INSTRUCTIONS

⚠ WARNING

Improper installation, adjustment, alteration, service or maintenance can cause property damage, personal injury or loss of life. Installation and service must be performed by a licensed professional HVAC installer or equivalent, service agency, or the gas supplier

LGH/LCH036, 048, 060, 072 & 074

3, 4, 5 and 6 Ton

GAS AND COOLING PACKAGED UNITS
507410-05
4/2019
Supersedes 10/2018

Table Of Contents

Dimensions	Page 2
Parts Arrangements	Page 3
Shipping and Packing List	Page 5
General	Page 5
Requirements	Page 5
Unit Support	Page 6
Duct Connection	Page 6
Rigging Unit For Lifting	Page 7
Horizontal Air Discharge	Page 7
Condensate Drains	Page 7
Gas Piping	Page 9
Pressure Test Gas Piping	Page 10

High Altitude Derate	Page 10
Electrical Connections	Page 11
Blower Operation and Adjustments	Page 13
Cooling Start-Up	Page 46
Cooling Operation	Page 57
Gas Heat Start-Up	Page 60
Heating Operation and Adjustments	Page 61
Electric Heat Start-Up	Page 62
Advanced Air Flow Control Start-Up	Page 62
Hot Gas Reheat Startup	Page 65
Service	Page 67
Factory Unit Controller Settings	Page 70

⚠ CAUTION

As with any mechanical equipment, contact with sharp sheet metal edges can result in personal injury. Take care while handling this equipment and wear gloves and protective clothing.

RETAIN THESE INSTRUCTIONS FOR FUTURE REFERENCE

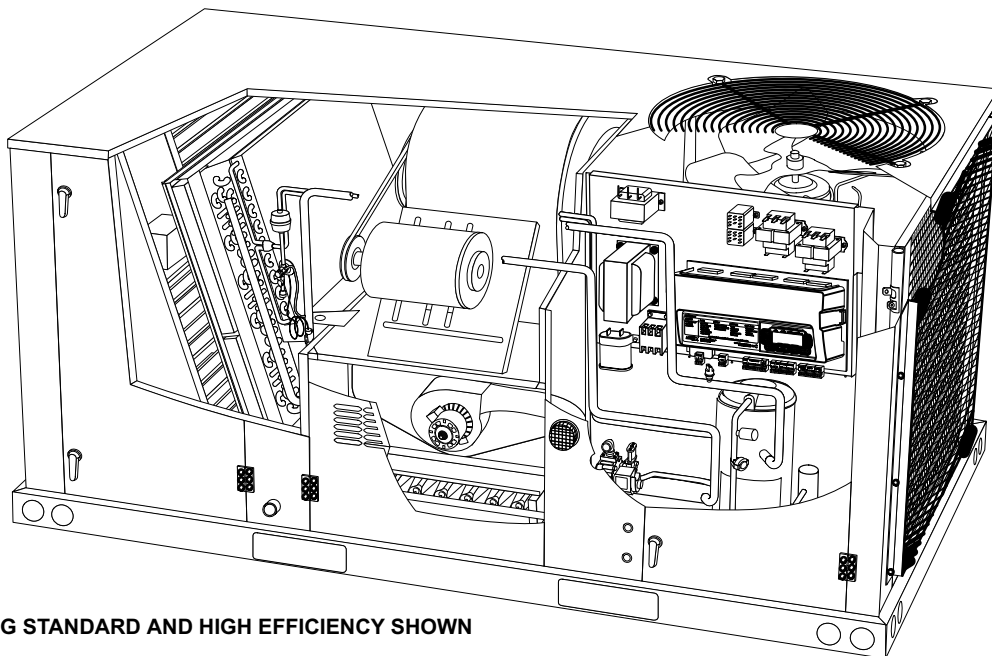

LG STANDARD AND HIGH EFFICIENCY SHOWN

LGH/LCH036, 048, 060, 072 & 074 DIMENSIONS in. - Gas heat section shown

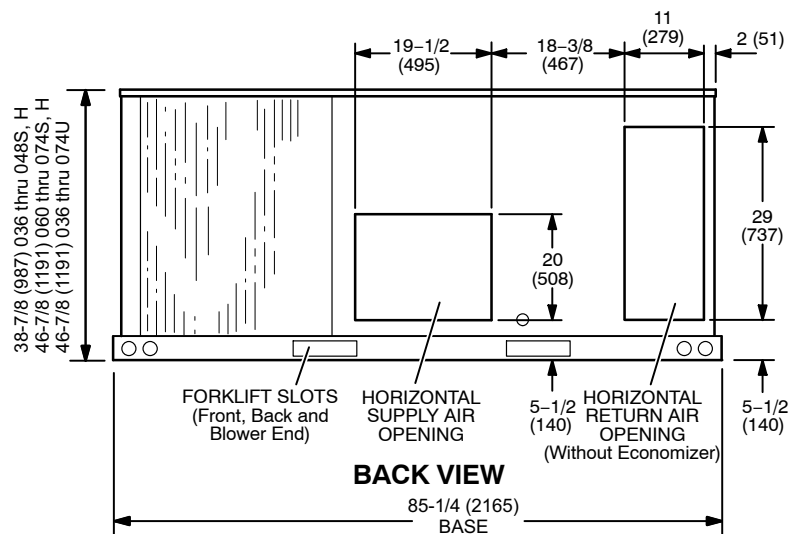
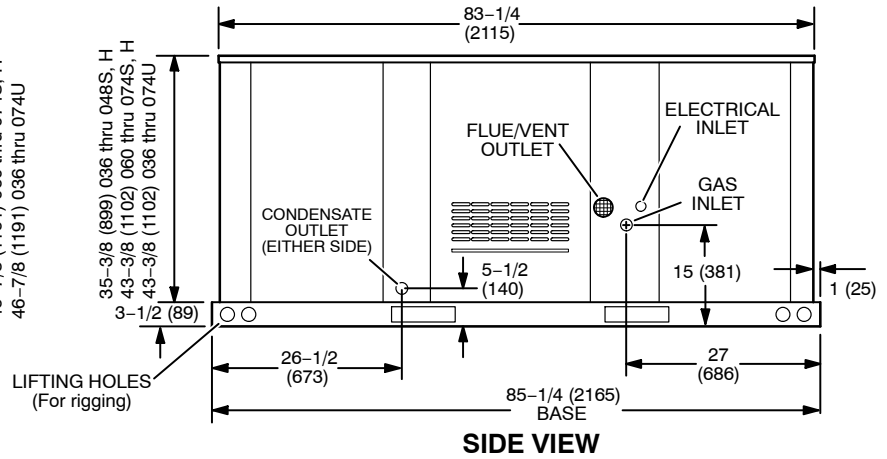
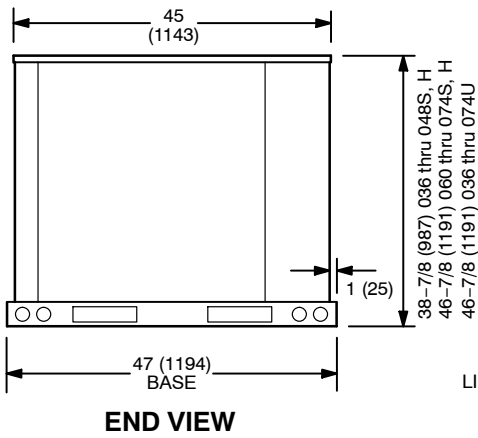
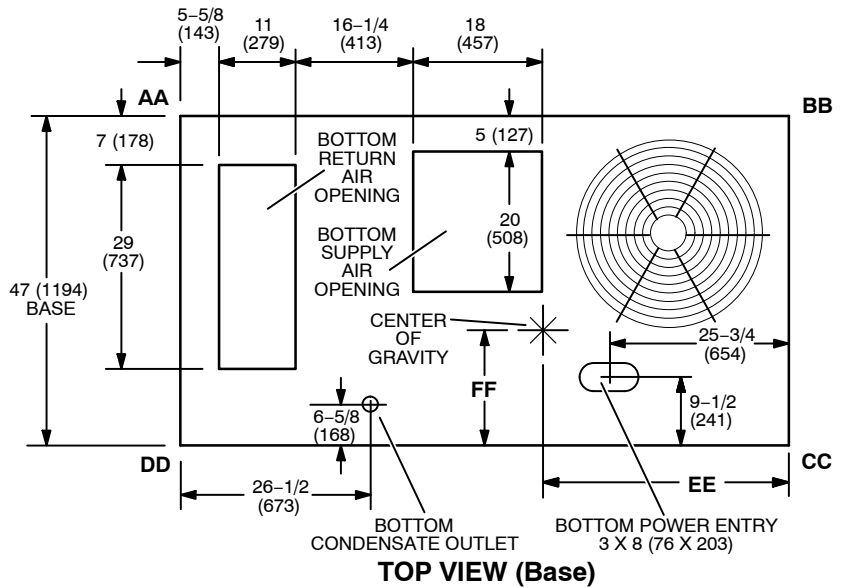

LGH036, 048, 060S, H & 072, 074H PARTS ARRANGEMENT

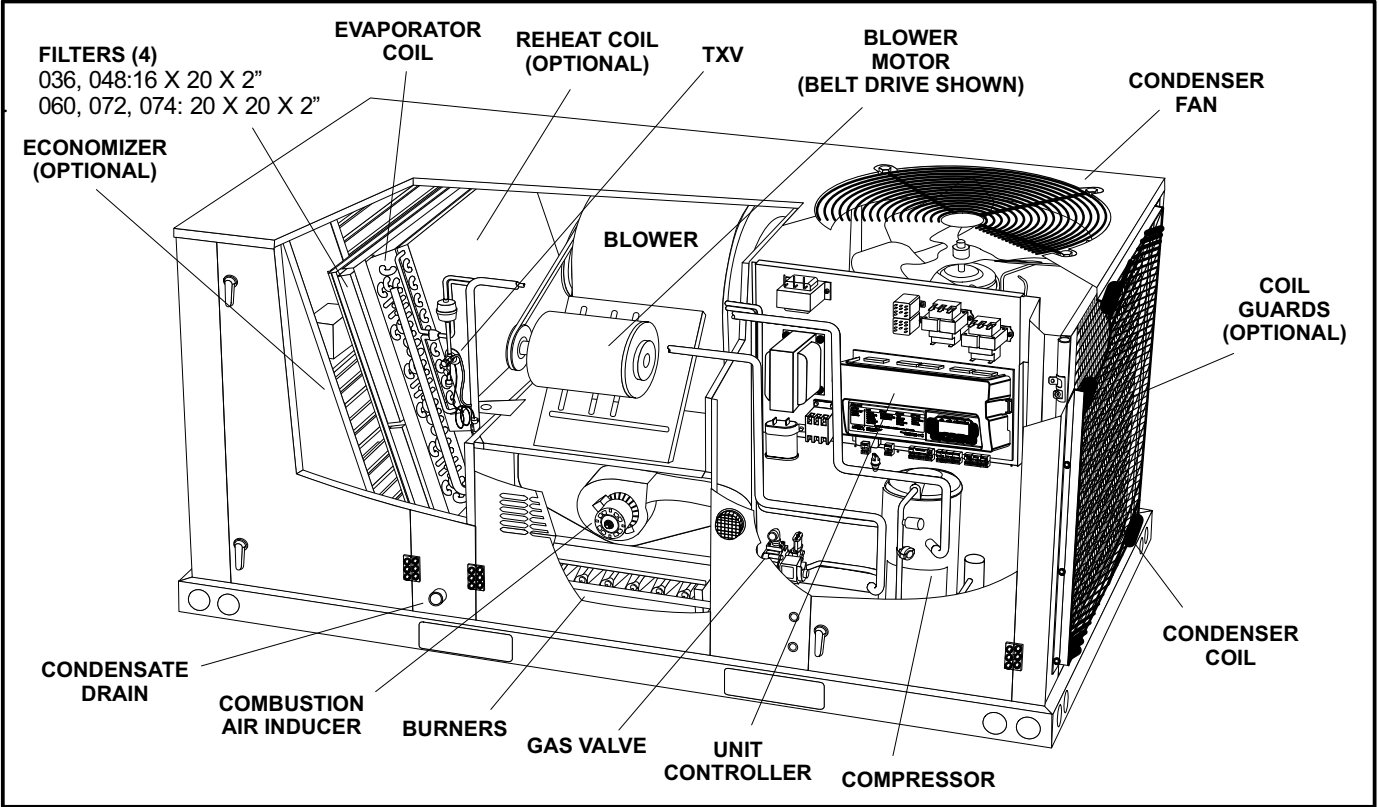

LCH036, 048, 060S, H & 072, 074H PARTS ARRANGEMENT

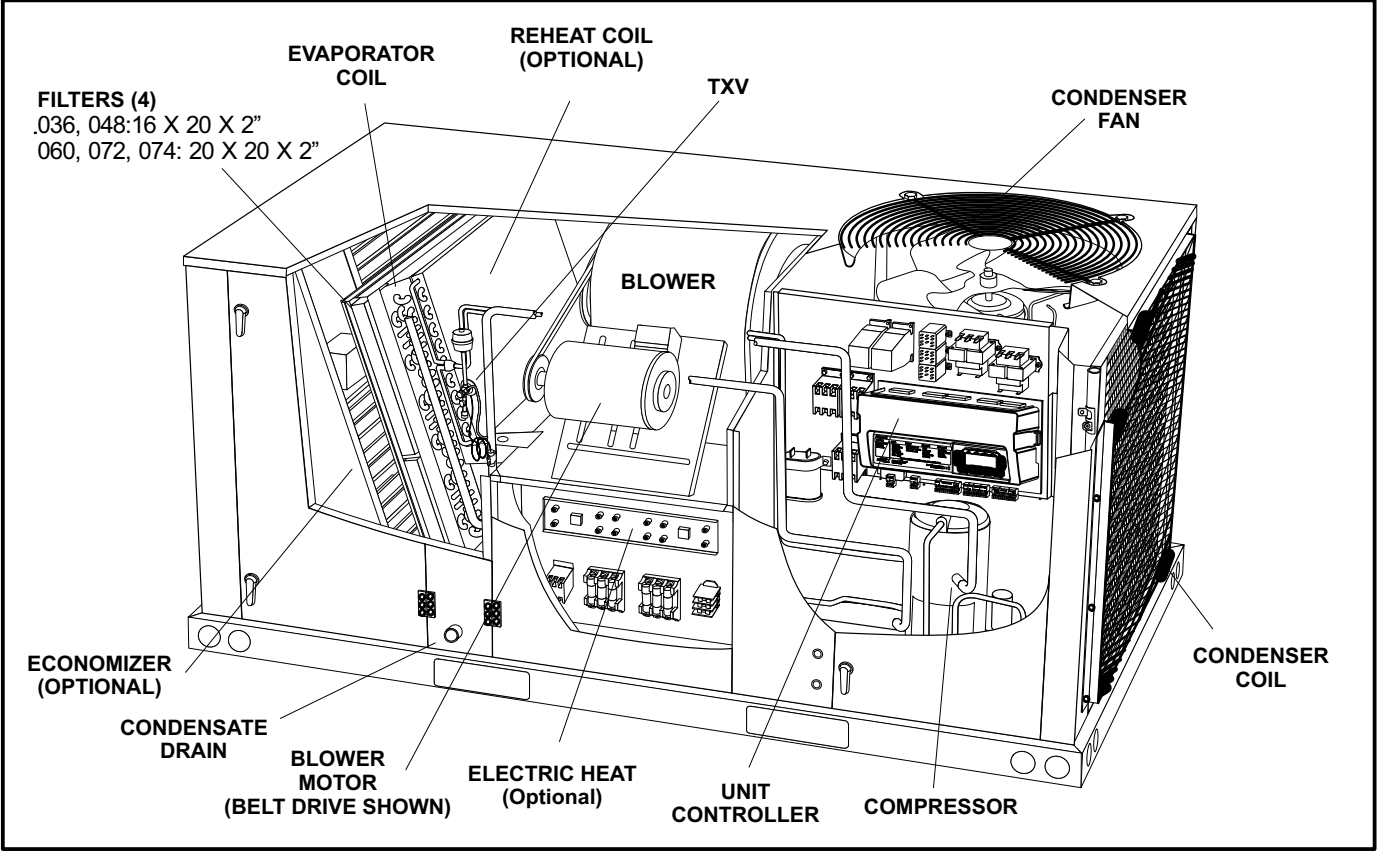

LGH036, 048, 060, 074U PARTS ARRANGEMENT

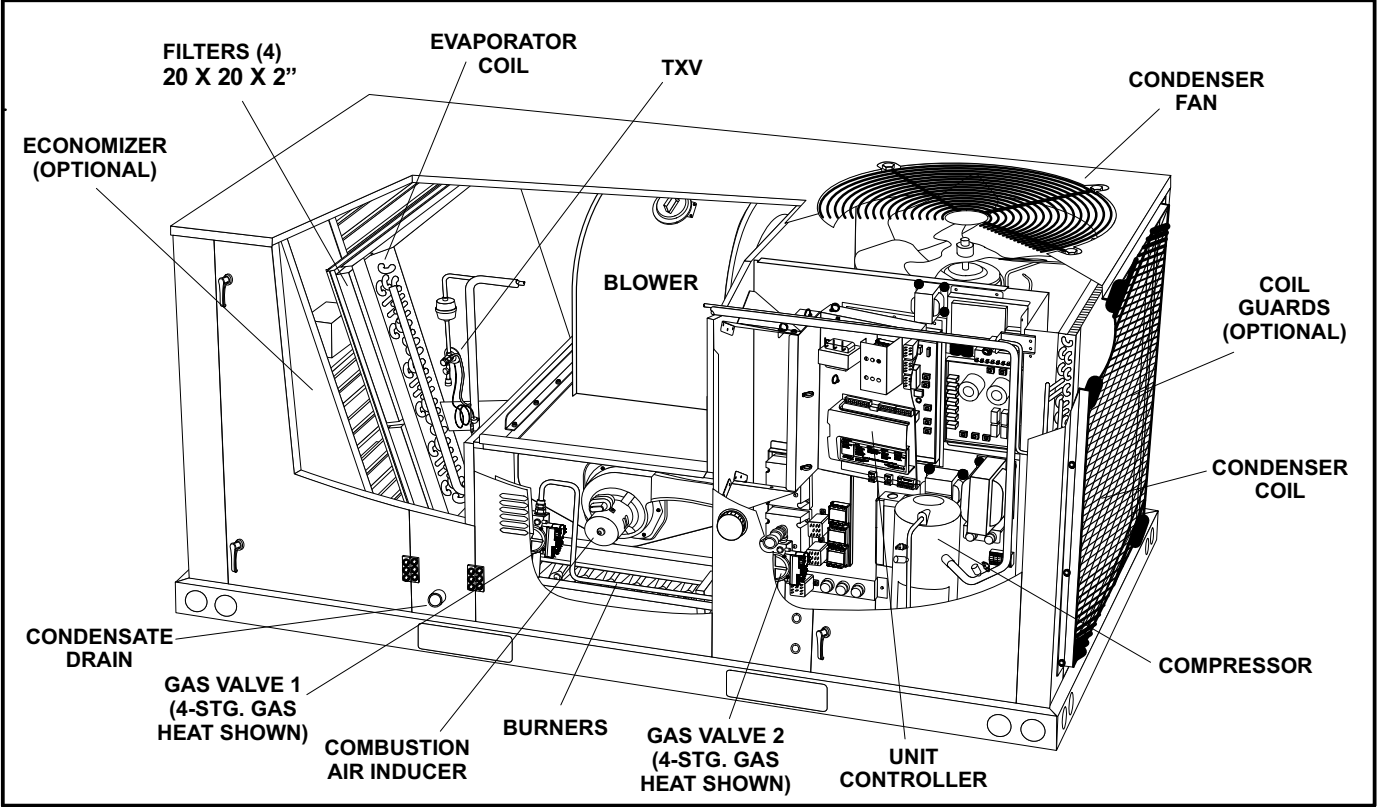

LCH036, 048, 060, 074U PARTS ARRANGEMENT

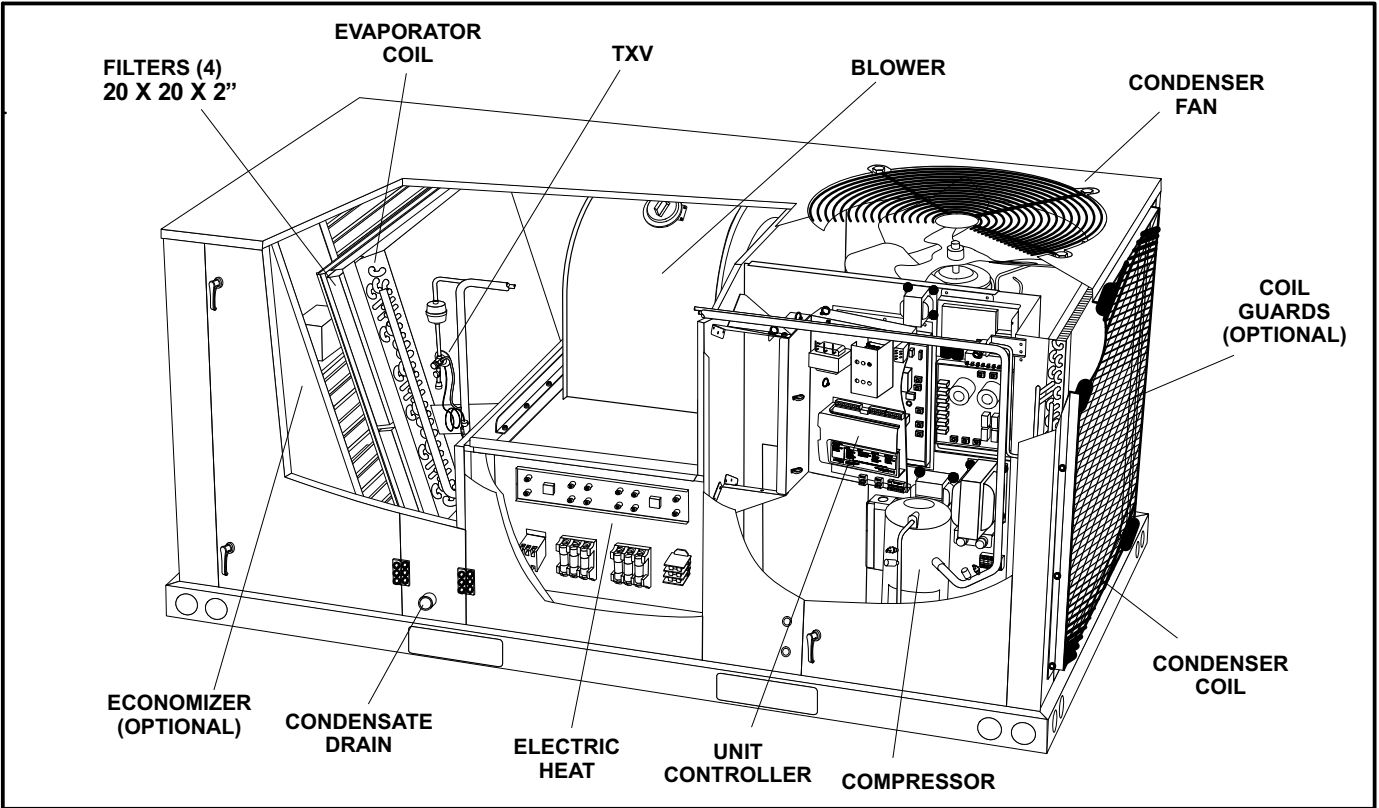

Shipping and Packing List

Package 1 of 1 contains:

1- Assembled unit
 Check unit for shipping damage. Receiving party should contact last carrier immediately if shipping damage is found.

General

These instructions are intended as a general guide and do not supersede local codes in any way. Authorities having jurisdiction should be consulted before installation.

The LGH units are available in several heating inputs. The LCH cooling packaged rooftop unit is the same basic design as the LGH unit except for the heating section. Optional electric heat is available for LCH units. LGH and LCH units have identical refrigerant circuits with respective 3, 4, 5, and 6 ton cooling capacities.

Standard and high efficiency units are equipped with a lightweight, all-aluminum condenser coil; optional fin/tube condenser coils are available. Ultra high efficiency units are equipped with fin/tube condenser coils.

Units are equipped with the compressors shown in table 1.

**TABLE 1
 COMPRESSORS**

Unit	T'Stat	Compressor
072H	2-Stage	Single-Speed
036S, 048S, 060S, 036H, 048H, 060H, 074H	2- or 3-Stage	2-Step Capacity
036U, 048U, 060U, 074U	2- or 3-Stage	Variable Speed, 2-Step Capacity
036U, 048U, 060U, 074U	Zone Sensor	Variable Speed

In addition to standard heating and cooling, hot gas reheat units provide a dehumidifying mode of operation. Refer to Reheat Operation section.

High efficiency units may be equipped with a Unit Controller that is factory-configured for "Advanced Air Flow Control". This option allows the installer to enter both the design-specified supply air CFM and outdoor air CFM. See the *Advanced Air Flow Control Start-Up* section. These units are equipped with a variable speed, direct drive blower and an economizer.

Availability of units and options varies by brand.

Requirements

See figure 1 for unit clearances.

⚠️ IMPORTANT

The Clean Air Act of 1990 bans the intentional venting of refrigerant (CFC's and HCFC's) as of July 1, 1992. Approved methods of recovery, recycling or reclaiming must be followed. Fines and/or incarceration may be levied for non-compliance.

⚠️ WARNING

Electric shock hazard and danger of explosion. Can cause injury, death or product or property damage. Turn off gas and electrical power to unit before performing any maintenance or servicing operations on the unit. Follow lighting instructions attached to unit when putting unit back into operation and after service or maintenance.

⚠️ NOTICE

Roof Damage!
 This system contains both refrigerant and oil. Some rubber roofing material may absorb oil, causing the rubber to swell. Bubbles in the rubber roofing material can cause leaks. Protect the roof surface to avoid exposure to refrigerant and oil during service and installation. Failure to follow this notice could result in damage to roof surface.

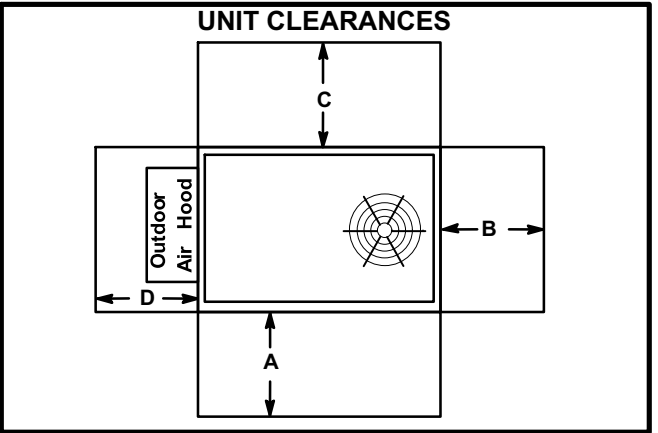

FIGURE 1

¹ Unit Clearance	A in.(mm)	B in.(mm)	C in.(mm)	D in.(mm)	Top Clearance
Service Clearance	48 (1219)	36 (914)	36 (914)	36 (914)	Unob- structed
Clearance to Combustibles	36 (914)	1 (25)	1 (25)	1 (25)	Unob- structed
Minimum Operation Clearance	36 (914)	36 (914)	36 (914)	36 (914)	Unob- structed

Note - Entire perimeter of unit base requires support when elevated above mounting surface.

- ¹ **Service Clearance** - Required for removal of serviceable parts.
- Clearance to Combustibles** - Required clearance to combustible material (gas units).
- Minimum Operation Clearance** - Required clearance for proper unit operation.

Use of this unit as a construction heater or air conditioner is not recommended during any phase of construction. Very low return air temperatures, harmful vapors and operation of the unit with clogged or misplaced filters will damage the unit.

If this unit has been used for heating or cooling of buildings or structures under construction, the following conditions must be met or the warranty will be void:

- A room thermostat must control the unit. The use of fixed jumpers that will provide continuous heating or cooling is not allowed.
- A pre-filter must be installed at the entry to the return air duct.
- The return air duct must be provided and sealed to the unit.
- Return air temperature range between 55°F (13°C) and 80°F (27°C) must be maintained.
- Air filters must be replaced and pre-filters must be removed upon construction completion.
- The input rate and temperature rise must be set per the unit rating plate.
- The heat exchanger, components, duct system, air filters and evaporator coil must be thoroughly cleaned following final construction clean-up.
- The unit operating conditions (including airflow, cooling operation, ignition, input rate, temperature rise and venting) must be verified according to these installation instructions.

Unit Support

In downflow discharge installations, install the unit on a non-combustible surface only. Unit may be installed on combustible surfaces when used in horizontal discharge applications or in downflow discharge applications when installed on an T1CURB / C1CURB / E1CURB roof mounting frame.

NOTE - Securely fasten roof frame to roof per local codes.

⚠ CAUTION

To reduce the likelihood of supply / return air bypass and promote a proper seal with the RTU, duct work / duct drops / diffuser assemblies must be supported independently to the building structure.

A-Downflow Discharge Application

Roof Mounting with T1CURB / C1CURB / E1CURB

- 1- The roof mounting frame must be installed, flashed and sealed in accordance with the instructions provided with the frame.
- 2- The roof mounting frame should be square and level to 1/16" per linear foot (5mm per linear meter) in any direction.

- 3- Duct must be attached to the roof mounting frame and not to the unit; supply and return plenums must be installed before setting the unit.

Installer's Roof Mounting Frame

Many types of roof frames can be used to install the unit depending upon different roof structures. Items to keep in mind when using the building frame or supports are:

- 1- The base is fully enclosed and insulated, so an enclosed frame is not required.
- 2- The frames or supports must be constructed with non-combustible materials and should be square and level to 1/16" per linear foot (5mm per linear meter) in any direction.
- 3- Frame or supports must be high enough to prevent any form of moisture from entering unit. Recommended minimum frame height is 14" (356mm).
- 4- Duct must be attached to the roof mounting frame and not to the unit. Supply and return plenums must be installed before setting the unit.
- 5- Units require support along all four sides of unit base. Supports must be constructed of steel or suitably treated wood materials.

NOTE-When installing a unit on a combustible surface for downflow discharge applications, a T1CURB / C1CURB / E1CURB roof mounting frame is required.

B-Horizontal Discharge Applications

- 1- Units which are equipped with an optional economizer and installed in horizontal airflow applications must use a horizontal conversion kit.
- 2- Specified installation clearances must be maintained when installing units. Refer to figure 1.
- 3- Top of support slab should be approximately 4" (102mm) above the finished grade and located so no run-off water from higher ground can collect around the unit.
- 4- Units require support along all four sides of unit base. Supports must be constructed of steel or suitably treated wood materials.

Duct Connection

All exterior ducts, joints and openings in roof or building walls must be insulated and weather-proofed with flashing and sealing compounds in accordance with applicable codes. Any duct passing through an unconditioned space must be insulated.

⚠ CAUTION

In downflow applications, do not drill or punch holes in base of unit. Leaking in roof may occur if unit base is punctured.

Rigging Unit For Lifting

Rig unit for lifting by attaching four cables to holes in unit base rail. See figure 2.

- 1- Detach wooden base protection before rigging.
- 2- Remove all six base protection brackets before setting unit.
- 3- Connect rigging to the unit base using both holes in each corner.
- 4- All panels must be in place for rigging.
- 5- Place field-provided H-style pick in place just above top edge of unit. Frame must be of adequate strength and length. (H-style pick prevents damage to unit.)

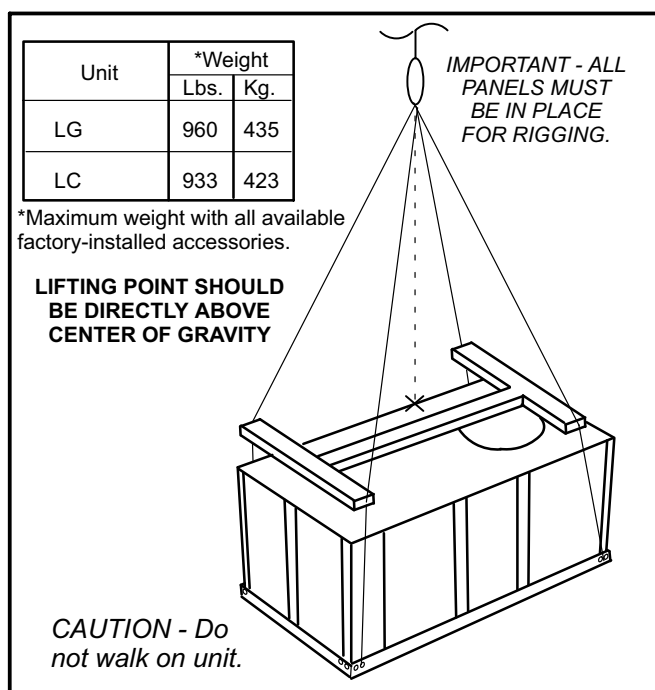

FIGURE 2

Horizontal Air Discharge

Unit is shipped with panels covering the horizontal supply and return air openings. Remove horizontal covers and place over downflow openings for horizontal air discharge. See figure 3. Secure in place with sheet metal screws.

Units Equipped With An Optional Economizer

- 1- Remove the horizontal supply air cover and position over the downflow supply air opening. Secure with sheet metal screws.
- 2- Leave the horizontal return air cover in place.
- 3- Locate the separately ordered horizontal air discharge kit. Place the kit panel over the downflow return air opening.
- 4- Remove and retain the barometric relief dampers and lower hood.

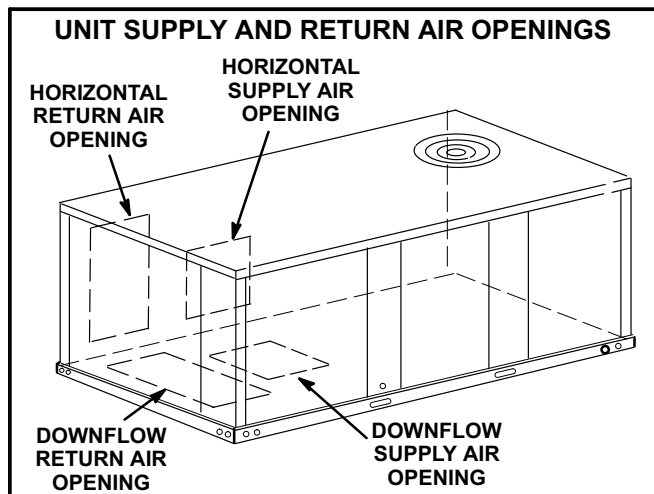

FIGURE 3

- 5- Install return air duct beneath outdoor air intake. See figure 4. Install barometric relief damper in lower hood and install in ductwork as shown in figure 4.

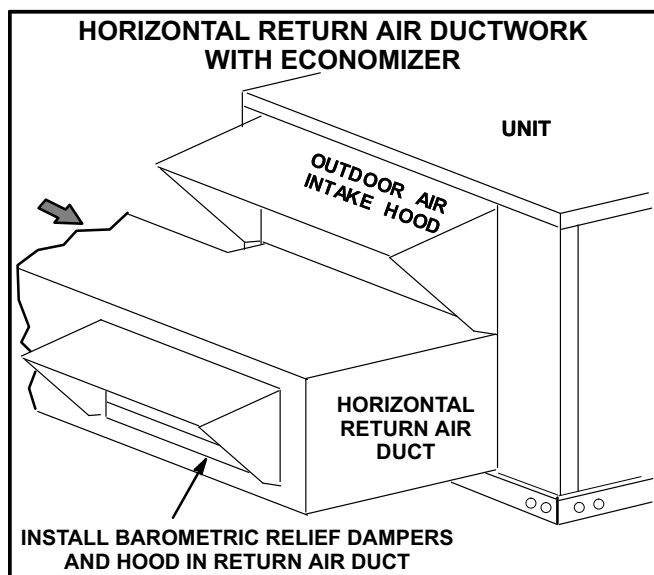

FIGURE 4

Condensate Drains

Make drain connection to the drain coupling provided on unit. Older model units have a 3/4" N.P.T. coupling and newer model units have a 1" N.P.T. coupling.

Note - The drain pan is made with a glass reinforced engineered plastic capable of withstanding typical joint torque but can be damaged with excessive force. Tighten pipe nipple hand tight and turn an additional quarter turn.

A trap must be installed between drain connection and an open vent for proper condensate removal. See figure 5 or 6. It is sometimes acceptable to drain condensate onto the roof or grade; however, a tee should be fitted to the trap to direct condensate downward. The condensate line must be vented. Check local codes concerning condensate disposal. Refer to pages 1 and 2 for condensate drain location.

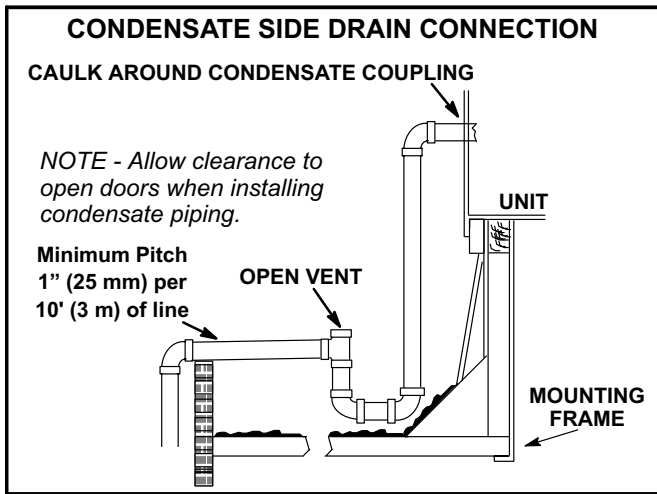

FIGURE 5

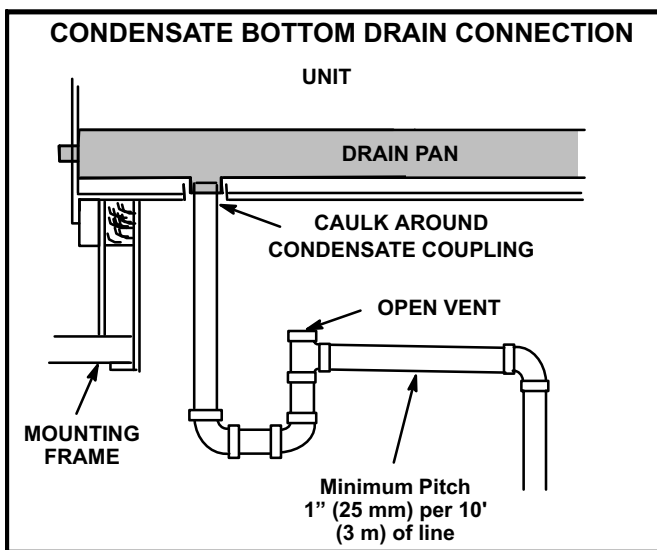

FIGURE 6

Units are shipped with the drain coupling facing the front of the unit. Condensate can be drained from the back or bottom of the unit with the following modifications. The unit can be installed in either downflow or horizontal air discharge regardless of condensate drain location.

Rear Drain Connection

- 1- Remove the condensate drain mullion. See figure 7. Remove the two panels on each side of the mullion.

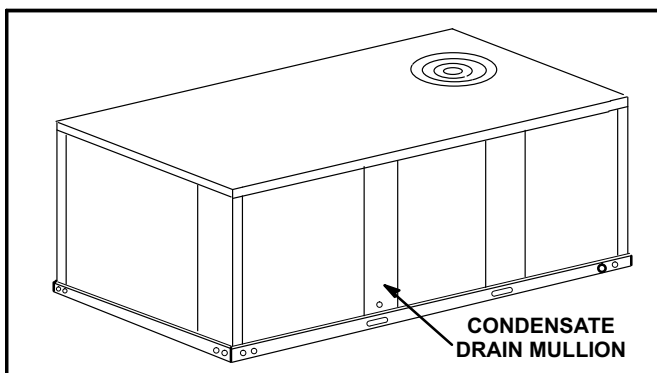

FIGURE 7

Two hinge screws must be removed in addition to the mullion screws. See figure 8.

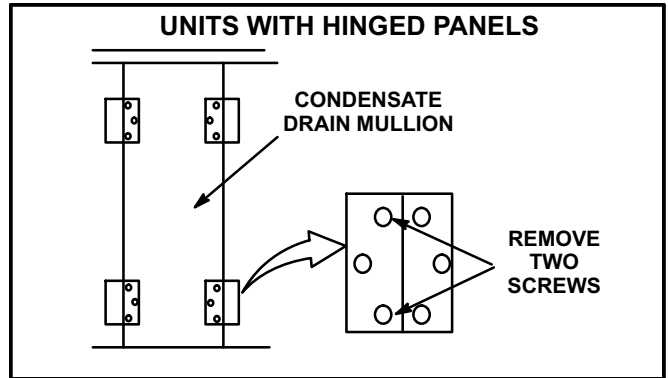

FIGURE 8

- 2- Lift the front edge of the drain pan and slide pan out of unit. See figure 9.

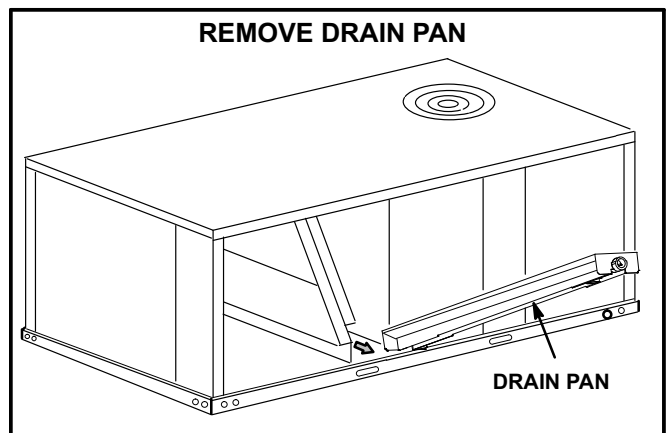

FIGURE 9

- 3- Make sure the cap over the unit bottom drain hole is secure.
- 4- Rotate the drain pan until the downward slope is toward the back of the unit. Slide the drain pan back into the unit. Be careful not to dislodge the cap over the bottom drain hole.
- 5- From the back side of the unit, pull the drain pan coupling through the rear condensate opening.
- 6- Replace the condensate drain mullion.

Bottom Drain Connection

- 1- Remove the condensate drain mullion. See figure 7.
- 2- Lift the front edge of the drain pan and slide pan out of unit. See figure 9.
- 3- Turn the drain pan upside down and drill a pilot hole through the bottom of the drain pan in the center of the coupling. See figure 10.

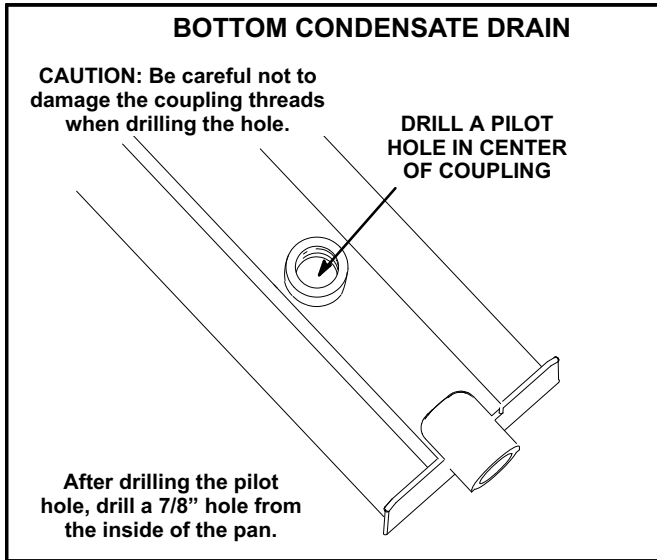

FIGURE 10

- 4- From the inside of the pan, use a Vari-Bit® bit to enlarge the hole to 7/8". Do not damage coupling threads.
- 5- Remove the cap over the unit bottom drain hole.
- 6- Slide the drain pan back into the unit.
- 7- From the back side of the unit, pull the drain pan coupling through the rear condensate opening.
- 8- From the front side of the unit, move the drain pan until the bottom coupling settles into the unit bottom drain opening. Once in place, check to make sure the coupling is still positioned through the rear condensate drain hole.
- 9- Use a field-provided 3/4" plug to seal side drain connection.
- 10- Replace the condensate drain mullion.

Connect Gas Piping (Gas Units)

Before connecting field-provided piping, check with gas company or authorities having jurisdiction for local code requirements. When installing gas supply piping, length of run from gas meter must be considered in determining pipe size for 0.5" w.c. (.12kPa) maximum pressure drop. Do not use supply pipe smaller than unit gas connection. Operating pressures at the unit gas connection must be as shown in table 2.

**TABLE 2
OPERATING PRESSURE AT GAS CONNECTION "w.c."**

	Natural Gas		LP / Propane Gas	
	Min.	Max.	Min.	Max.
036-074	4.5	10.5	11	13

When making piping connections a drip leg should be installed on vertical pipe runs to serve as a trap for sediment or condensate. A 1/8" N.P.T. plugged tap is located on gas valve for test gauge connection. Refer to Heating Start-Up section for tap location. Install a ground joint union between the gas control manifold and the main manual shut-off valve. See figure 11 for gas supply piping entering outside the unit. Figure 12 shows complete bottom gas entry piping.

Compounds used on threaded joints of gas piping shall be resistant to the action of liquified petroleum gases.

Do not use Teflon® tape to seal gas piping. Use a moderate amount of pipe compound on the gas pipe only. Make sure the two end threads are bare.

⚠ CAUTION

If a flexible gas connector is required or allowed by the authority that has jurisdiction, black iron pipe shall be installed at the gas valve and extend outside the furnace cabinet.

⚠ WARNING

Do not exceed 600 in-lbs (50 ft.-lbs) torque when attaching the gas piping to the gas valve.

⚠ IMPORTANT

Compounds used on threaded joints of gas piping must be resistant to the actions of liquified petroleum gases.

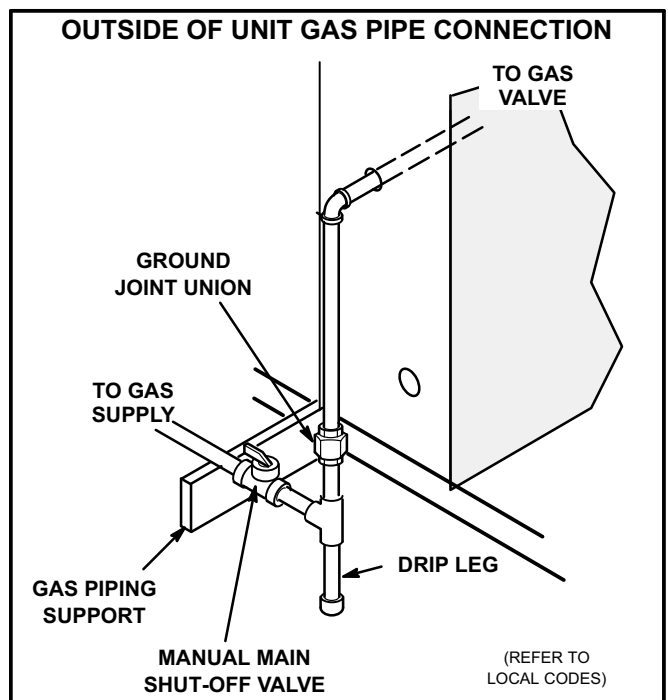

FIGURE 11

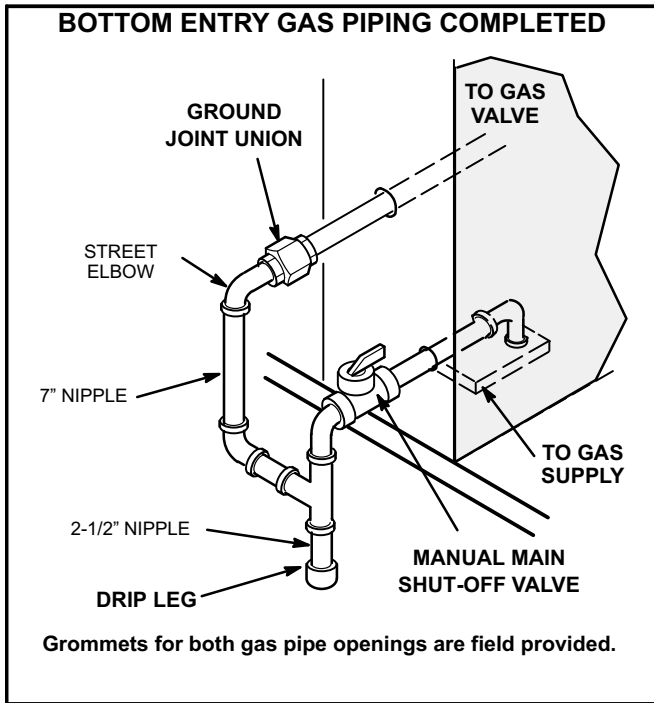

FIGURE 12

Pressure Test Gas Piping (Gas Units)

When pressure testing gas lines, the gas valve must be disconnected and isolated. Gas valves can be damaged if subjected to more than 0.5 psig (3.48kPa). See figure 13.

NOTE-Codes may require that manual main shut-off valve and union (furnished by installer) be installed in gas line external to unit. Union must be of the ground joint type.

After all connections have been made, check all piping connections for gas leaks. Also check existing unit gas connections up to the gas valve; loosening may occur during installation. Use a leak detection solution or other preferred means. Do not use matches candles or other sources of ignition to check for gas leaks.

⚠ CAUTION

Some soaps used for leak detection are corrosive to certain metals. Carefully rinse piping thoroughly after leak test has been completed. Do not use matches, candles, flame or othe sources of ignition to check for gas leaks.

⚠ WARNING

 Danger of explosion. Can cause injury or product or property damage. Do not use matches, candles, flame or other sources of ignition to check for leaks.

NOTE-In case emergency shut down is required, turn off the main manual shut-off valve and disconnect main power to unit. These devices should be properly labeled by the installer.

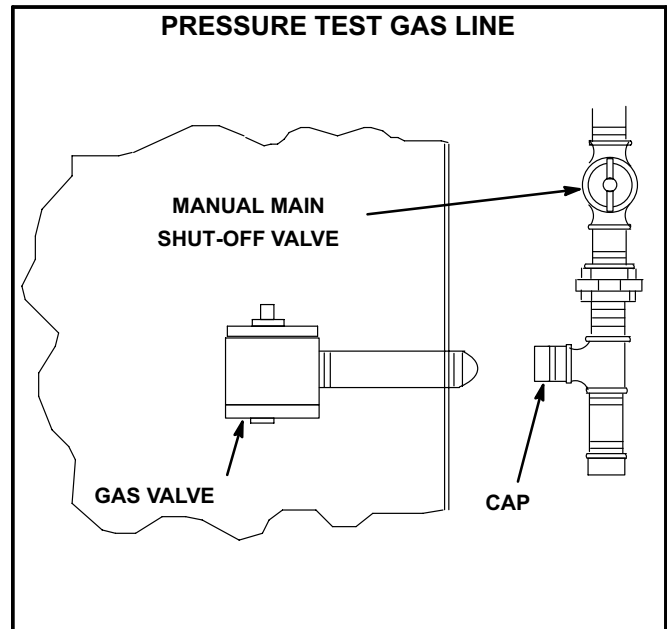

FIGURE 13

High Altitude Derate

Locate the high altitude conversion sticker in the unit literature bag. Fill out the conversion sticker and affix next to the unit nameplate.

Refer to table 3 for high altitude adjustments.

**TABLE 3
HIGH ALTITUDE DERATE**

Altitude Ft.*	Gas Manifold Pressure
2000-4500	See Unit Nameplate
4500 And Above	Derate 2% / 1000 Ft. Above Sea Level

*Units installed at 0-2000 feet do not need to be modified.

NOTE - This is the only permissible derate for these units.

Electrical Connections

POWER SUPPLY

Do not apply power or close disconnect switch until installation is complete. Refer to start-up directions. Refer closely to unit wiring diagram.

Refer to unit nameplate for minimum circuit ampacity and maximum fuse size.

- 1- Units are factory-wired for 230,460,575 volt supply. **For 208V supply**, remove the insulated terminal cover from the 208V terminal on the control transformer. Move the wire from the transformer 240V terminal to the 208V terminal. Place the insulated terminal cover on the unused 240V terminal.
- 2- Route power through the bottom power entry area and connect to L1, L2, and L3 on the top of K1 in control area above compressor. Secure power wiring with factory-installed wire ties provided in control box. Route power to TB2 on units equipped with electric heat. Route power to S48 or CB10 if unit is equipped with the optional disconnect switch or circuit breaker. See unit wiring diagram.

CONTROL WIRING

⚠ CAUTION

Electrostatic discharge can affect electronic components. Take precautions during unit installation and service to protect the electronic controls. Precautions will help to avoid control exposure to electrostatic discharge by putting the unit, the control and the technician at the same electrostatic potential. Neutralize electrostatic charge by touching hands and all tools on an unpainted unit surface, such as the gas valve or blower deck, before performing any service procedure.

A-Thermostat Location

Room thermostat mounts vertically on a standard 2" X 4" handy box or on any non-conductive flat surface.

Locate thermostat approximately 5 feet (1524mm) above the floor in an area with good air circulation at average temperature. Avoid locating the room thermostat where it might be affected by:

- drafts or dead spots behind doors and in corners
- hot or cold air from ducts
- radiant heat from sun or appliances
- concealed pipes and chimneys

B-Control Wiring

The Unit Controller will operate the unit from a thermostat or zone sensor based on the System Mode. The default System Mode is the thermostat mode. Refer to the Unit Controller Installation and Setup Guide to change the System Mode. Use the menu navigation arrows and select button; see *Settings - Install*.

Thermostat Mode

- 1- Route thermostat cable or wires from subbase to control area above compressor (refer to unit dimensions to locate bottom and side power entry).

IMPORTANT - Unless field thermostat wires are rated for maximum unit voltage, they must be routed away from line voltage wiring. Use wire ties located near the lower left corner of the controls mounting panel to secure thermostat cable.

Use 18 AWG wire for all applications using remotely installed electro-mechanical and electronic thermostats.

- 2- Install thermostat assembly in accordance with instructions provided with thermostat.
- 3- Connect thermostat wiring to Unit Controller on the lower side of the controls hat section.
- 4- Wire as shown in figure 14 for electro-mechanical and electronic thermostats. If using other temperature control devices or energy management systems see instructions and wiring diagram provided by manufacturer.

IMPORTANT - Terminal connections at the wall plate or subbase must be made securely. Loose control wire connections may allow unit to operate but not with proper response to room demand.

Zone Sensor Mode

The Unit Controller will operate heating and cooling based on the Unit Controller internal setpoints and the temperature from the A2 zone sensor. An optional Network Control Panel (NCP) can also be used to provide setpoints. A thermostat or return air sensor can be used as a back-up mode. Make zone sensor wiring connections as shown in figure 15.

Wire runs over 150 feet (mm):

Use a local, isolated 24VAC transformer such as Lennox cat #18M13 (20VA minimum) to supply power to RH sensor as shown in figure 17. Use two shielded cables containing 20AWG minimum, twisted pair conductors with overall shield. Belden type 8762 or 88760 (plenum) or equivalent.

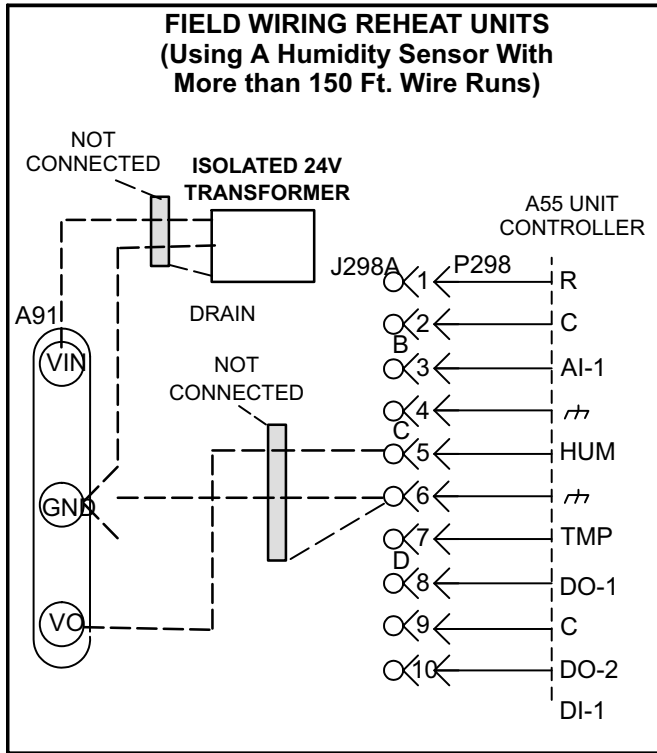

FIGURE 17

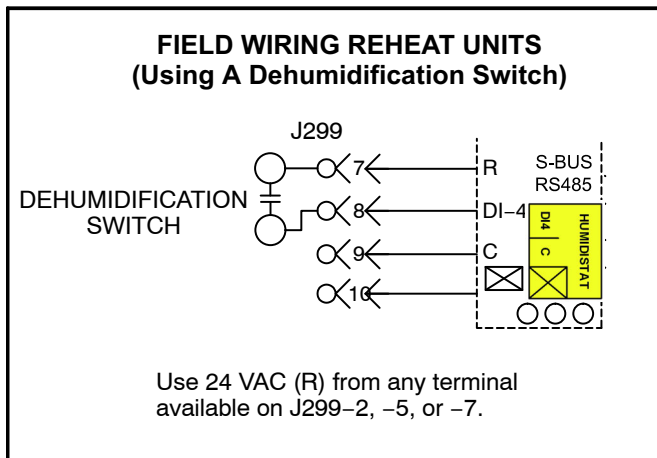

FIGURE 18

Blower Operation and Adjustments

Units are equipped with one of three factory-installed blower options. The ninth character in the model number identifies the blower as follows:

E= High efficiency three-, four- and five-ton units are equipped with a variable speed, direct drive blower. When these units are also equipped with an economizer and configured for Advanced Air Flow Control, the installer is able to enter the design-specified supply and outdoor air CFM into the Unit Controller. This eliminates the need to manually take measurements and adjust settings. See *Advanced Air Flow Control Start-Up* section.

Ultra high efficiency units are also equipped with a variable speed, direct drive blower. The installer is able to enter the design-specified supply air CFM into the Unit Controller for optimal efficiency. The Unit Controller calibrates the supply air volume which eliminates the need to manually take duct static measurements. Refer to *D-Adjusting Unit CFM - Ultra High Efficiency Direct Drive Blowers*.

T= Units are equipped with a two-stage belt drive blower.

B= Units are equipped with a single-stage belt drive blower.

Note - Six-ton, non-ultra high efficiency units are available with belt drive blowers only.

⚠ IMPORTANT

Three phase scroll compressors must be phased sequentially for correct compressor and blower rotation. Follow "COOLING START-UP" section of installation instructions to ensure proper compressor and blower operation.

A-Blower Operation

Refer to the Unit Controller Installation and Setup Guide to energize blower. Use the menu navigation arrows and select button; see *SERVICE > TEST*.

B-Determining Unit CFM

- 1- The following measurements must be made with air filters in place.

IMPORTANT - High Efficiency Units -

On units equipped with direct drive blowers, a low speed adjustment less than 2/3 of high speed will improve humidity removal; refer to product data for more information.

- 2- With all access panels in place, measure static pressure external to unit (from supply to return). Blower performance data is based on static pressure readings taken in locations shown in figure 19.

Note - Static pressure readings can vary if not taken where shown.

- 3- Measure the indoor blower wheel RPM.
- 4- Referring to the Blower Data tables, use static pressure and RPM readings to determine unit CFM. Use the Accessory Air Resistance tables when installing units with any of the options or accessories listed. Refer to table 4 or 5 for minimum airflow when electric heat is installed.

**TABLE 4
MINIMUM AIRFLOW-LCH UNITS WITH ELECTRIC HEAT (DIRECT DRIVE)**

kW	CFM	
	Downflow & Horizontal Airflow	
LCH036H, U	1080	
LCH048H, U	1280	
LCH060H, U LCH074U	1600	

**TABLE 5
MINIMUM AIRFLOW-LCH UNITS WITH ELECTRIC HEAT (BELT DRIVE)**

kW	CFM	
	Downflow	Horizontal
30	1900	2000
22.5	1500	1600
15	1200	1300
7.5	1050	1200

C-Adjusting Unit CFM - High Efficiency Direct Drive Blowers

Note - To adjust CFM on units configured for optional "Advanced Air Flow Control", refer to Advanced Air Flow Control Start-Up section.

The supply CFM can be adjusted by changing Unit Controller settings. Refer to table 6 for menu paths and default settings. Adjustments can also be made by using optional software. Record any CFM changes on the parameter settings label located on the inside of the compressor access panel.

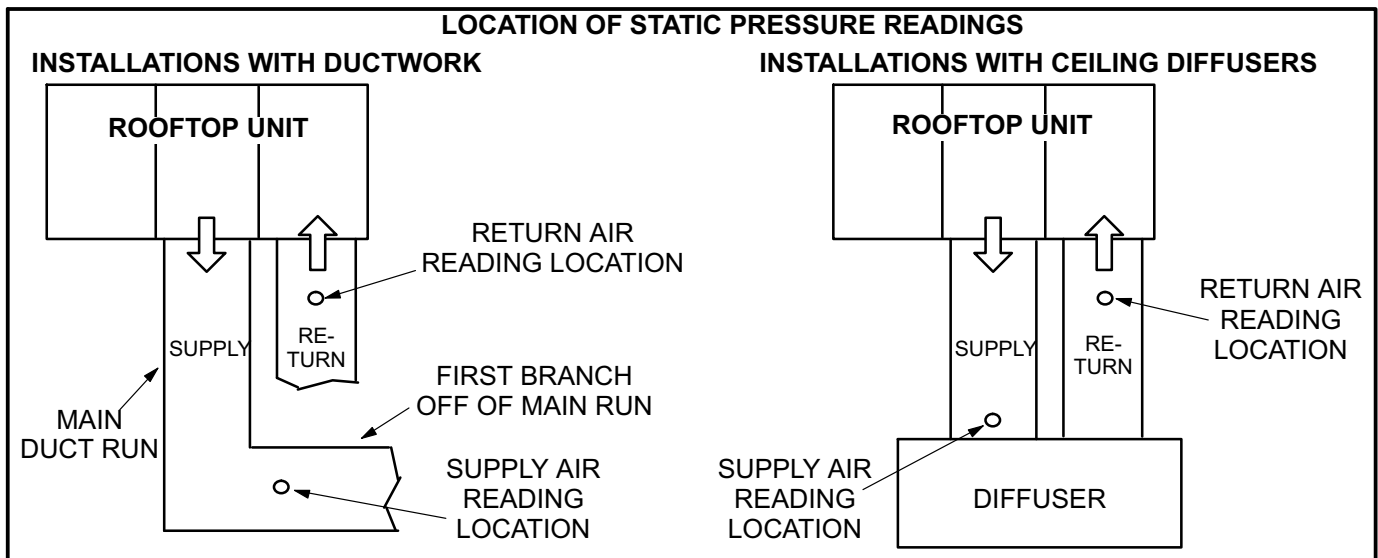

FIGURE 19

D-Adjusting Unit CFM - Ultra High Efficiency Direct Drive Blowers

The supply CFM can be adjusted by changing Unit Controller settings. Refer to table 7 for menu paths and default settings. Record any CFM changes on the parameter settings label located on the inside of the compressor access panel.

CAUTION

The BLOWER CALIBRATION process starts the indoor blower at operational speeds and moves the economizer damper blades. Before starting this process, replace any access panels and close all unit doors except compressor compartment door.

Blower calibration is required only on units that are newly installed or if there is a change in the duct work or air filters after installation. After the new CFM values are entered, use the down and up arrow buttons to select START CALIBRATION. Push SAVE to start calibration. The

blower calibration status is displayed as a % complete. Upon successful completion, the Unit Controller will display CALIBRATION SUCCESS and go back to the blower calibration screen. Press the MAIN MENU button to go to the main menu and press the BACK button to go to the status screen.

If only the CFM values are updated, use the down and up arrow buttons to select "CALIBRATION DONE". Push SAVE to enter the updated values. This selection will not initiate calibration, resulting in less setup time. Press the MAIN MENU button to go to the main menu and press the BACK button to go to the status screen.

IMPORTANT - On ultra high efficiency units, the default value for Cooling Low CFM is lower than a traditional single- or two-speed unit. If operating the unit with a 2- or 3-stage controller (2- or 3-stage thermostat, DDC controller, etc.), it is recommended to increase the Cooling Low CFM default value to a suitable level for part load cooling (typically 60% of full load CFM).

TABLE 6
036, 048, 060H DIRECT DRIVE PARAMETER SETTINGS

Parameter	LGH/LCH Unit Factory Default Settings				Field Setting	Description
	036 H4E	048 H4E	060 H4E	036-060 S4T		
SETUP > TEST & BALANCE > BLOWER						
HIGH SPEED	55%	58%	59%	Not Applicable		Percentage torque for indoor blower high speed.
LOW SPEED	28%	33%	36%	Not Applicable		Percentage torque for indoor blower low speed.
SETUP > TEST & BALANCE > DAMPER						
BLOWER ON HIGH	0%	0 %	0 %	0 %		Minimum damper position during high speed blower operation.
BLOWER ON LOW	0%	0%	0%	Not Applicable		Minimum damper position during low speed blower operation.
SETTINGS > RTU OPTIONS > EDIT PARAMETER = 6						
BLOWER SMOKE OUTPUT	55%	58%	59%	Not Applicable		Percentage torque for indoor blower smoke speed.
SETTINGS > RTU OPTIONS > EDIT PARAMETER = 10 (Applies to Thermostat Mode ONLY)						
FREE COOLING STAGE-UP DELAY	300 sec.	300 sec.	300 sec.	300 sec.	sec	Number of seconds to hold indoor blower at low speed before switching to indoor blower at high speed.

Installer: Circle applicable unit model number and record any parameter changes under "Field Setting" column. Settings need to be recorded by installer for use when Unit Controller is replaced or reprogrammed.

TABLE 7
036, 048, 060, 074U DIRECT DRIVE PARAMETER SETTINGS

LGH/LCH036-074U4E Parameter Settings						
Parameter	Factory Setting				Field Setting	Description
	036	048	060	074		
Note: Any changes to Smoke CFM setting must be adjusted before the other CFM settings. Use SETTINGS > RTU OPTIONS > EDIT PARAMETERS = 12						
BLOWER SMOKE CFM	1200	1600	2000	2400	CFM	Smoke blower speed
SETUP > TEST & BALANCE > BLOWER						
BLOWER HEATING HIGH CFM	1200	1600	2000	2000	CFM	High heat blower speed
BLOWER HEATING LOW CFM	N/A	1250	1250	1250	CFM	Low heat blower speed (applies to 150kBtuh 4-stg. gas heat only)
BLOWER COOLING HIGH CFM	1100	1450	1825	2200	CFM	High cooling blower speed
BLOWER COOLING LOW CFM	575	750	950	950	CFM	Low cooling blower speed
BLOWER VENTILATION CFM	575	750	950	1150	CFM	Ventilation blower speed
SETUP > TEST & BALANCE > DAMPER						
BLOWER HIGH CFM DAMPER POS %	0%	0%	0%	0%	%	Minimum damper position for high speed blower operation.
BLOWER LOW CFM DAMPER POS %	0%	0%	0%	0%	%	Minimum damper position for low speed blower operation.
POWER EXHAUST DAMPER POS %	50%	50%	50%	50%	%	Minimum damper position for power exhaust operation.
SETTINGS > RTU OPTIONS > EDIT PARAMETERS = 216						
POWER EXHAUST DEAD-BAND %	10%	10%	10%	10%	%	Deadband % for power exhaust operation.
SETTINGS > RTU OPTIONS > EDIT PARAMETER = 10 (Applies to Thermostat Mode ONLY)						
FREE COOLING STAGE-UP DELAY	300 sec.	300 sec.	300 sec.	300 sec.	sec	Number of seconds to hold indoor blower at low speed before switching to indoor blower at high speed.

Installer: Circle applicable unit model number and record any parameter changes under "Field Setting" column. Settings need to be recorded by installer for use when Unit Controller is replaced or reprogrammed.

D-Adjusting Unit CFM - Belt Drive Blowers

The blower RPM can be adjusted at the motor pulley. Loosen Allen screw and turn adjustable pulley clockwise to increase CFM. Turn counterclockwise to decrease CFM. See figure 21. Do not exceed minimum and maximum number of pulley turns as shown in table 8.

**TABLE 8
MINIMUM AND MAXIMUM PULLEY ADJUSTMENT**

Belt	Min. Turns Open	Maxi. Turns Open
A Section	No minimum	5

E-Blower Belt Adjustment - Belt Drive

Maximum life and wear can be obtained from belts only if proper pulley alignment and belt tension are maintained. Tension new belts after a 24-48 hour period of operation. This will allow belt to stretch and seat grooves. Make sure blower and motor pulley are aligned as shown in figure 20.

- 1- Loosen four bolts securing motor base to mounting frame. See figure 21.
- 2- *To increase belt tension* - Slide blower motor downward to tighten the belt. This increases the distance between the blower motor and the blower housing.

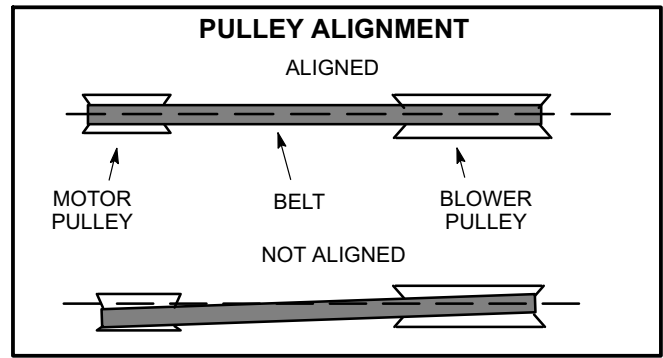

FIGURE 20

3- *To loosen belt tension* -

Slide blower motor upward to loosen the belt. This decreases the distance between the blower motor and the blower housing.

- 4- Tighten four bolts securing motor base to the mounting frame.

F-Blower Belt Adjustment - Units Equipped With An Optional Belt Tensioner

- 1- Remove blower belt.
- 2- Remove bracket from blower housing. See figure 23.
- 3- Remove the screw from the back side of the bracket.
- 4- Move the tensioner to the appropriate adjustment hole and reinstall screw.
- 5- Replace bracket.
- 6- Replace blower belt. See figure 24.

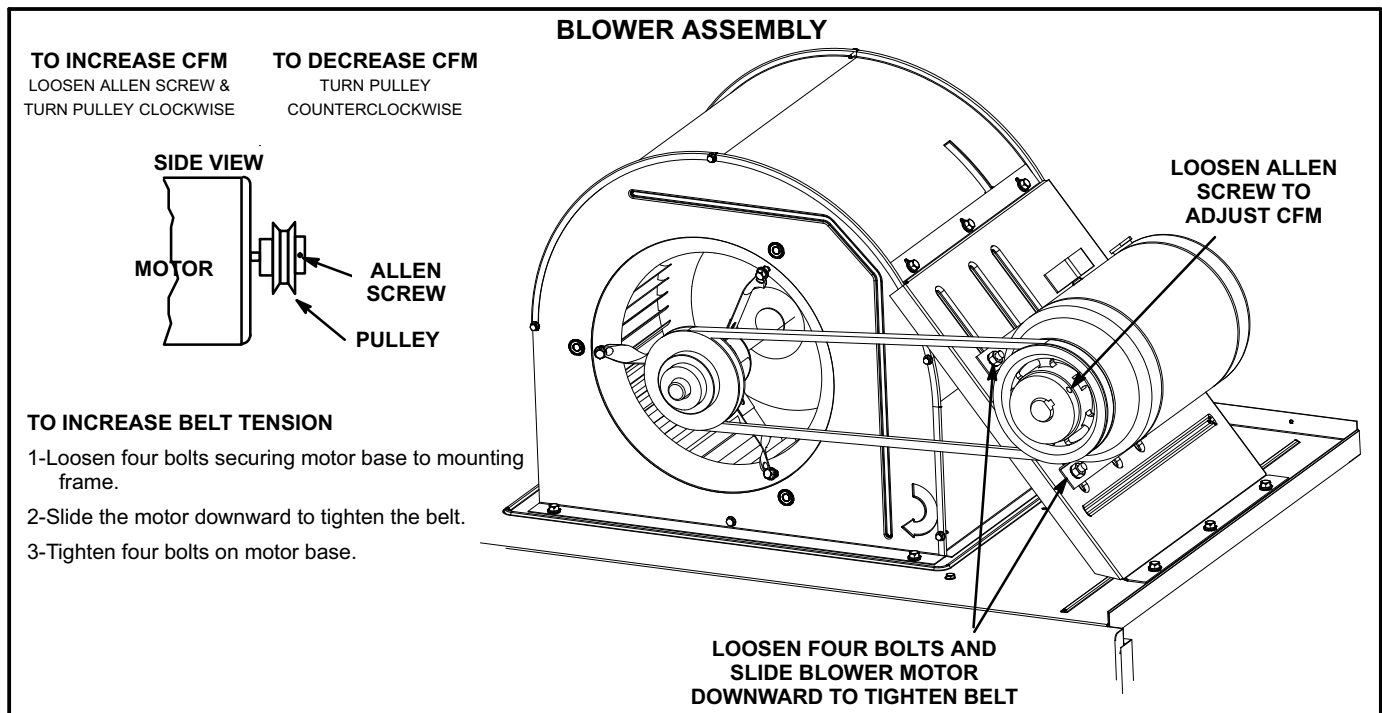

FIGURE 21

G-Check Belt Tension

Overtensioning belts shortens belt and bearing life. Check belt tension as follows:

- 1- Measure span length X. See figure 22.
- 2- Apply perpendicular force to center of span (X) with enough pressure to deflect belt 1/64" for every inch of span length or 1.5mm per 100mm of span length.
Example: Deflection distance of a 40" span would be 40/64" or 5/8".
Example: Deflection distance of a 400mm span would be 6mm.

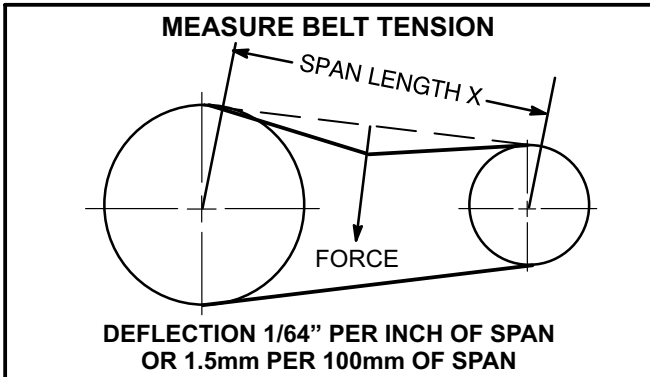

FIGURE 22

- 3- Measure belt deflection force. For a used belt, the deflection force should be 5 lbs. (35kPa). A new belt deflection force should be 7 lbs. (48kPa).
A force below these values indicates an undertensioned belt. A force above these values indicates an overtensioned belt.

H-Field-Furnished Blower Drives

For field-furnished blower drives, use page 20 through 44 to determine BHP and RPM required. Reference page 45 to determine the drive kit number. Reference table 9 for manufacturer's drive numbers.

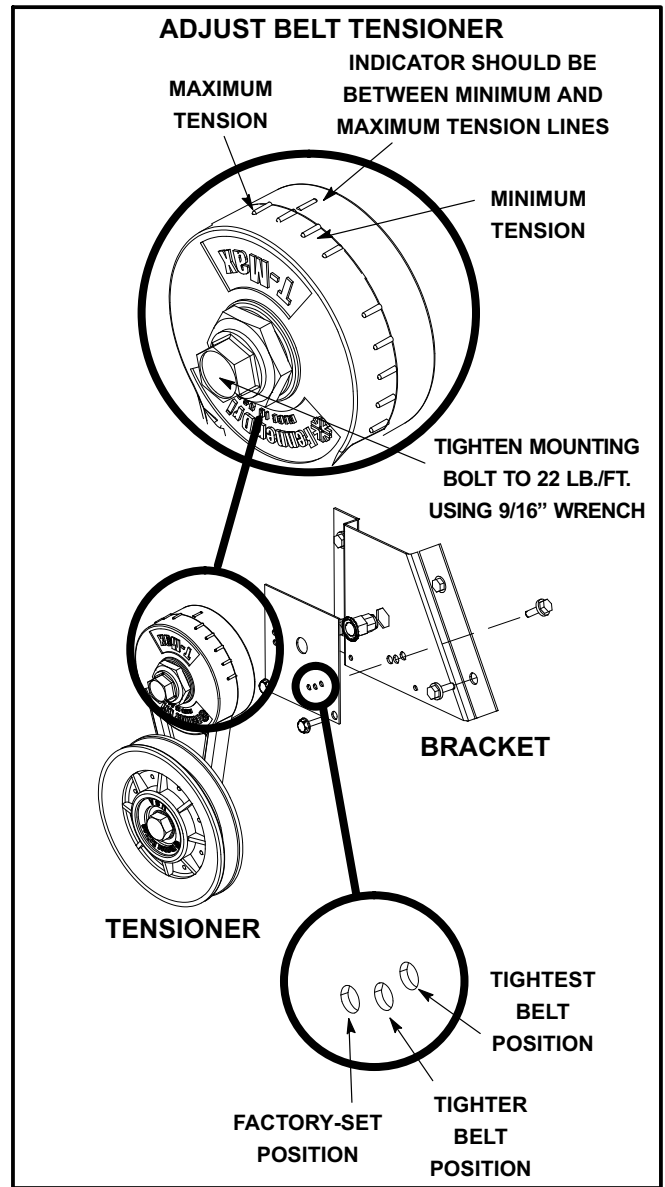
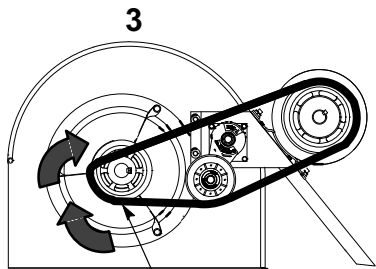
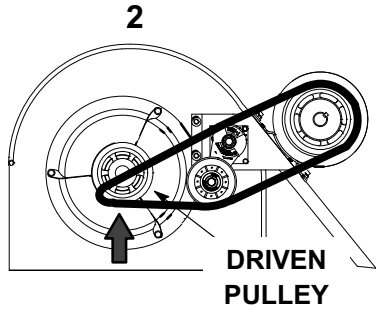
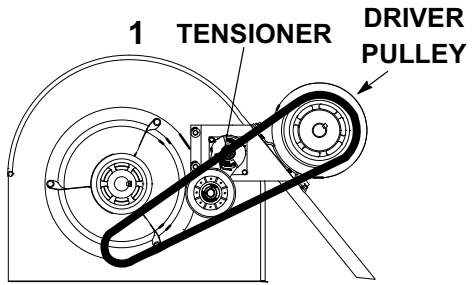

FIGURE 23

INSTALL BELT



ROTATE DRIVEN PULLEY TO SEAT BELT

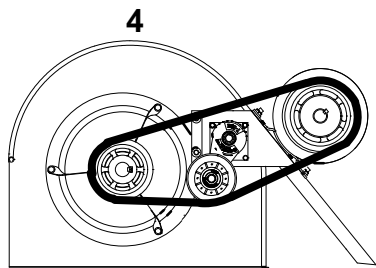

FIGURE 24

BLOWER DATA - LGH DIRECT DRIVE - 3 TON - HIGH EFFICIENCY

BLOWER TABLE INCLUDES RESISTANCE FOR BASE UNIT ONLY WITH DRY INDOOR COIL AND AIR FILTERS IN PLACE.FOR ALL UNITS.ADD:

1 - Any factory installed options air resistance (heat section, economizer, etc.).

2 - Any field installed accessories air resistance (duct resistance, diffuser, etc.).

See page 45 for wet coil and options/accessory air resistance data.

NOTE - Default Speed Settings (percentage of blower torque) - Low 28% / High 55%

DOWNFLOW

External Static Press. in. w.g.	Percentage of Total Motor Torque																										
	20%		30%		40%		50%		60%		70%		80%		90%		100%										
	Cfm	Watts	RPM	Cfm	Watts	RPM	Cfm	Watts	RPM	Cfm	Watts	RPM	Cfm	Watts	RPM	Cfm	Watts	RPM									
0	796	39	407	975	69	451	1154	98	494	1298	140	567	1442	181	639	1570	236	692	1697	292	744	1807	357	785	1917	422	825
0.1	719	44	482	915	76	523	1110	108	564	1257	151	626	1404	193	687	1537	248	733	1670	304	779	1784	369	815	1898	433	850
0.2	663	49	538	864	83	585	1064	117	633	1220	160	679	1375	203	725	1508	259	770	1641	316	815	1754	384	853	1866	452	891
0.3	593	55	607	806	91	651	1018	126	695	1174	171	737	1330	216	780	1471	272	815	1612	328	850	1724	398	890	1835	469	930
0.4	527	60	665	749	97	708	971	135	751	1136	180	783	1300	225	815	1435	285	858	1569	344	900	1689	413	930	1809	481	959
0.5	460	65	722	692	104	761	924	143	801	1090	190	833	1256	238	866	1398	296	899	1540	355	932	1662	424	960	1784	493	988
0.6	---	---	---	---	---	---	855	154	864	1033	202	889	1211	250	914	1361	308	939	1511	365	963	1629	437	995	1746	508	1028
0.7	---	---	---	---	---	---	808	161	898	995	209	922	1181	258	946	1325	319	976	1468	379	1007	1588	450	1036	1708	522	1065
0.8	---	---	---	---	---	---	743	170	942	940	220	966	1137	269	991	1281	331	1020	1425	392	1049	1548	463	1074	1670	533	1100
0.9	---	---	---	---	---	---	676	178	979	884	229	1006	1092	280	1033	1237	342	1061	1381	404	1088	1513	472	1105	1645	539	1121
1.0	---	---	---	---	---	---	605	187	1011	819	240	1049	1032	294	1087	1192	353	1100	1352	411	1112	1474	480	1137	1595	549	1161
1.1	---	---	---	---	---	---	---	---	---	---	---	---	988	304	1124	1142	364	1141	1295	424	1158	1420	490	1177	1544	555	1195
1.2	---	---	---	---	---	---	---	---	---	---	---	---	---	---	---	---	---	---	1251	433	1189	1373	495	1207	1494	558	1225

HORIZONTAL

External Static Press. in. w.g.	Percentage of Total Motor Torque																										
	20%		30%		40%		50%		60%		70%		80%		90%		100%										
	Cfm	Watts	RPM	Cfm	Watts	RPM	Cfm	Watts	RPM	Cfm	Watts	RPM	Cfm	Watts	RPM	Cfm	Watts	RPM									
0	807	44	372	982	65	431	1157	86	490	1299	126	546	1441	167	602	1565	214	647	1688	262	692	1795	328	734	1901	393	776
0.1	708	50	468	906	77	513	1103	104	559	1247	143	612	1391	183	666	1522	231	704	1652	280	742	1766	346	779	1879	413	815
0.2	634	56	541	841	88	583	1048	120	625	1206	156	663	1363	192	701	1491	243	742	1619	294	783	1731	361	820	1843	429	857
0.3	523	63	648	759	98	669	994	134	690	1150	171	729	1306	209	769	1446	258	796	1585	307	823	1696	376	860	1807	444	896
0.4	437	69	732	688	107	742	939	146	752	1101	183	785	1263	221	818	1399	273	849	1535	326	881	1653	392	908	1771	458	935
0.5	344	75	823	615	116	817	885	156	812	1053	194	838	1220	232	865	1361	285	892	1502	339	918	1614	406	949	1725	473	980
0.6	---	---	---	---	---	---	817	167	883	990	207	905	1162	246	927	1307	301	949	1451	356	971	1570	420	993	1689	484	1014
0.7	---	---	---	---	---	---	762	174	938	941	215	954	1119	256	971	1269	312	988	1418	367	1005	1536	430	1026	1653	494	1047
0.8	---	---	---	---	---	---	708	178	991	892	222	1002	1076	266	1013	1222	324	1034	1368	383	1054	1484	444	1073	1599	506	1092
0.9	---	---	---	---	---	---	645	182	1050	832	230	1059	1019	277	1068	1168	337	1084	1317	397	1100	1431	456	1117	1545	516	1134
1.0	---	---	---	---	---	---	584	184	1105	780	235	1106	976	285	1107	1122	348	1125	1267	411	1144	1379	467	1158	1491	522	1172
1.1	---	---	---	---	---	---	---	---	---	---	---	---	923	295	1155	1070	359	1169	1217	423	1184	1327	475	1195	1436	526	1207
1.2	---	---	---	---	---	---	---	---	---	---	---	---	---	---	---	---	---	---	1166	434	1222	1265	481	1234	1364	527	1246

BLOWER DATA - LCH DIRECT DRIVE - 3 TON - HIGH EFFICIENCY

BLOWER TABLE INCLUDES RESISTANCE FOR BASE UNIT ONLY WITH DRY INDOOR COIL AND AIR FILTERS IN PLACE.

FOR ALL UNITS ADD:

- 1 - Any factory installed options air resistance (heat section, economizer, etc.).
- 2 - Any field installed accessories air resistance (duct resistance, diffuser, etc.).

See Page 45 for blower motors and drives and wet coil and options/accessory air resistance data.

DOWNFLOW

External Static Press. in. w.g.	Percentage of Total Motor Torque																										
	20%		30%		40%		50%		60%		70%		80%		90%		100%										
	Cfm	RPM	Cfm	RPM	Cfm	RPM	Cfm	RPM	Cfm	RPM	Cfm	RPM	Cfm	RPM	Cfm	RPM	Cfm	RPM	Cfm	RPM							
0	785	38	407	969	68	468	1152	98	529	1301	140	581	1449	182	634	1571	236	683	1693	290	732	1799	352	770	1904	414	809
0.1	720	44	475	919	74	522	1117	104	569	1264	150	626	1411	195	684	1539	248	724	1667	301	765	1772	366	805	1877	431	844
0.2	645	50	550	851	83	593	1056	116	637	1218	161	680	1380	205	722	1509	259	762	1638	313	802	1744	380	840	1849	446	879
0.3	570	56	620	793	90	651	1016	124	681	1175	172	730	1334	220	779	1468	274	813	1601	328	846	1708	396	883	1815	464	920
0.4	505	60	678	731	97	712	956	135	746	1130	182	781	1303	229	815	1434	286	852	1564	342	889	1676	410	920	1787	477	951
0.5	432	65	740	663	105	775	895	145	810	1076	194	839	1257	243	867	1396	298	895	1534	353	923	1647	421	952	1759	489	981
0.6	---	---	---	---	---	---	855	152	852	1033	204	884	1211	256	917	1351	312	944	1490	369	971	1604	437	997	1718	505	1024
0.7	---	---	---	---	---	---	792	163	916	986	213	933	1180	264	949	1320	321	975	1460	379	1002	1575	447	1026	1690	515	1050
0.8	---	---	---	---	---	---	734	173	975	934	224	985	1134	275	995	1275	334	1021	1416	393	1046	1533	460	1067	1649	527	1088
0.9	---	---	---	---	---	---	674	183	1034	881	234	1037	1088	286	1039	1230	346	1064	1371	406	1088	1490	471	1106	1608	537	1123
1.0	---	---	---	---	---	---	613	193	1095	820	246	1094	1026	300	1093	1184	357	1104	1342	414	1115	1448	480	1140	1553	547	1165
1.1	---	---	---	---	---	---	---	---	---	---	---	---	980	309	1131	1139	367	1142	1297	425	1154	1404	488	1173	1511	551	1192
1.2	---	---	---	---	---	---	---	---	---	---	---	---	---	---	---	---	---	---	1253	436	1190	1355	495	1207	1456	554	1225

HORIZONTAL

External Static Press. in. w.g.	Percentage of Total Motor Torque																										
	20%		30%		40%		50%		60%		70%		80%		90%		100%										
	Cfm	RPM	Cfm	RPM	Cfm	RPM	Cfm	RPM	Cfm	RPM	Cfm	RPM	Cfm	RPM	Cfm	RPM	Cfm	RPM	Cfm	RPM	Cfm	RPM	Cfm	RPM	Cfm	RPM	
0	796	43	372	975	64	447	1155	85	524	1302	126	560	1448	168	597	1566	214	639	1684	260	680	1786	323	720	1888	386	761
0.1	709	50	461	909	75	512	1110	101	564	1254	143	613	1398	185	662	1523	231	695	1649	277	729	1754	344	769	1858	411	810
0.2	617	57	553	828	88	591	1040	118	629	1204	156	664	1368	194	698	1492	243	734	1616	291	771	1721	358	808	1826	424	845
0.3	503	64	662	747	97	668	992	131	676	1151	172	722	1310	212	768	1442	260	794	1574	308	820	1681	374	853	1787	440	887
0.4	419	69	747	671	107	746	924	146	747	1095	185	782	1266	225	818	1398	275	844	1530	325	870	1640	389	899	1749	454	927
0.5	323	75	843	589	117	832	857	159	821	1039	198	844	1221	237	867	1359	287	888	1496	337	909	1598	403	941	1701	470	973
0.6	---	---	---	---	---	---	817	165	871	990	208	900	1162	252	929	1296	306	954	1431	360	979	1546	421	995	1662	481	1010
0.7	---	---	---	---	---	---	747	176	957	933	219	966	1118	262	974	1264	314	987	1410	367	1000	1523	427	1016	1636	487	1032
0.8	---	---	---	---	---	---	700	181	1026	886	226	1022	1073	271	1018	1216	327	1035	1359	383	1051	1469	442	1066	1579	501	1081
0.9	---	---	---	---	---	---	643	187	1110	829	235	1091	1015	283	1073	1161	341	1087	1307	399	1101	1409	456	1118	1510	513	1136
1.0	---	---	---	---	---	---	592	190	1197	781	241	1154	970	291	1113	1114	352	1130	1258	413	1147	1355	467	1161	1452	520	1176
1.1	---	---	---	---	---	---	---	---	---	---	---	---	915	300	1162	1067	362	1171	1219	424	1180	1312	473	1192	1405	522	1204
1.2	---	---	---	---	---	---	---	---	---	---	---	---	---	---	---	---	---	---	1168	437	1223	1248	480	1235	1329	523	1246

BLOWER DATA - LGH DIRECT DRIVE - 4 TON - HIGH EFFICIENCY

BLOWER TABLE INCLUDES RESISTANCE FOR BASE UNIT ONLY WITH DRY INDOOR COIL AND AIR FILTERS IN PLACE.FOR ALL UNITS ADD:

1 - Any factory installed options air resistance (heat section, economizer, etc.).

2 - Any field installed accessories air resistance (duct resistance, diffuser, etc.).

See page 45 for wet coil and options/accessory air resistance data.

NOTE - Default Speed Settings (percentage of blower torque) - Low 40% / High 80%

DOWNFLOW

External Static Press. in. w.g.	Percentage of Total Motor Torque																								
	20%		30%		40%		50%		60%		70%		80%		90%		100%								
	Cfm	Watts	RPM	Cfm	Watts	RPM	Cfm	Watts	RPM	Cfm	Watts	RPM	Cfm	Watts	RPM	Cfm	Watts	RPM							
0	1048	80	507	1261	135	582	1473	190	657	1655	274	729	1836	359	801	1987	461	863	924	2291	698	975	2445	832	1025
0.1	1000	88	560	1218	146	633	1436	204	706	1624	289	771	1812	374	836	1965	479	896	956	2261	716	1004	2403	849	1052
0.2	944	97	624	1177	156	683	1409	214	743	1595	304	812	1781	393	881	1940	497	934	2098	2235	729	1032	2372	856	1077
0.3	906	104	666	1139	166	728	1372	228	790	1561	320	858	1750	412	925	1915	515	970	2079	2079	619	1015	2341	863	1100
0.4	849	113	728	1093	177	783	1336	241	837	1531	333	897	1726	425	957	1889	532	1004	2052	2177	754	1090	2302	869	1129
0.5	793	121	790	1047	188	837	1300	254	883	1501	346	935	1702	438	987	1864	548	1036	2026	2145	766	1120	2263	874	1155
0.6	---	---	---	---	---	---	1263	267	929	1467	361	978	1671	454	1027	1836	564	1071	2000	2116	775	1145	2232	876	1175
0.7	---	---	---	---	---	---	1226	280	974	1433	375	1019	1639	470	1065	1807	578	1104	1974	2080	782	1173	2186	878	1203
0.8	---	---	---	---	---	---	1195	291	1012	1402	388	1057	1608	485	1101	1778	591	1135	1948	2052	787	1195	2155	878	1220
0.9	---	---	---	---	---	---	1162	304	1060	1367	401	1097	1572	498	1134	1741	603	1168	1909	2009	792	1223	2109	875	1244
1.0	---	---	---	---	---	---	1133	316	1104	1333	414	1136	1533	511	1167	1702	612	1198	1870	2129	791	1251	2047	868	1272
1.1	---	---	---	---	---	---	---	---	---	---	---	---	1490	524	1200	1654	618	1228	1817	2129	786	1273	2000	859	1289
1.2	---	---	---	---	---	---	---	---	---	---	---	---	---	---	---	1765	701	1272	1844	2129	771	1293	1923	840	1314

HORIZONTAL

External Static Press. in. w.g.	Percentage of Total Motor Torque																										
	20%		30%		40%		50%		60%		70%		80%		90%		100%										
	Cfm	Watts	RPM	Cfm	Watts	RPM	Cfm	Watts	RPM	Cfm	Watts	RPM	Cfm	Watts	RPM	Cfm	Watts	RPM									
0	1025	80	472	1238	131	552	1450	182	632	1626	254	702	1802	326	771	1936	414	824	2071	502	878	2231	634	931	2391	767	983
0.1	978	85	546	1199	138	610	1420	191	675	1601	265	738	1781	339	801	1930	441	862	2079	544	923	2222	663	968	2365	783	1013
0.2	927	89	602	1157	145	661	1387	201	720	1568	279	783	1749	357	845	1906	458	897	2062	559	949	2205	679	993	2348	798	1038
0.3	851	98	684	1098	156	731	1344	214	777	1531	295	833	1717	375	888	1876	478	938	2035	581	988	2166	694	1030	2297	807	1072
0.4	801	105	738	1051	166	785	1300	227	832	1493	309	881	1685	392	930	1847	496	977	2009	600	1023	2128	707	1064	2247	813	1105
0.5	725	118	817	991	179	850	1256	239	883	1455	324	926	1653	408	970	1814	516	1019	1974	623	1068	2091	720	1099	2207	817	1130
0.6	---	---	---	---	---	---	1212	251	931	1417	337	969	1621	423	1008	1784	531	1053	1947	638	1098	2057	729	1126	2166	820	1154
0.7	---	---	---	---	---	---	1169	263	975	1380	350	1010	1590	437	1045	1756	544	1086	1921	651	1127	2014	736	1157	2106	821	1187
0.8	---	---	---	---	---	---	1114	277	1027	1331	366	1059	1547	454	1091	1717	560	1126	1886	666	1161	1976	743	1184	2066	821	1207
0.9	---	---	---	---	---	---	1062	290	1077	1283	380	1106	1504	470	1135	1669	575	1170	1833	680	1204	1919	749	1220	2005	817	1236
1.0	---	---	---	---	---	---	1007	304	1127	1240	392	1147	1473	481	1166	1627	584	1202	1780	687	1238	1853	748	1253	1925	809	1269
1.1	---	---	---	---	---	---	---	---	---	---	---	---	1429	497	1211	1569	590	1240	1709	683	1269	1787	741	1280	1864	799	1291
1.2	---	---	---	---	---	---	---	---	---	---	---	---	---	---	---	1604	651	1284	1684	714	1303	1763	777	1321	1763	840	1314

BLOWER DATA - LCH DIRECT DRIVE - 4 TON - HIGH EFFICIENCY

BLOWER TABLE INCLUDES RESISTANCE FOR BASE UNIT ONLY WITH DRY INDOOR COIL AND AIR FILTERS IN PLACE.

FOR ALL UNITS ADD:

- 1 - Any factory installed options air resistance (heat section, economizer, etc.).
- 2 - Any field installed accessories air resistance (duct resistance, diffuser, etc.).

See Page 45 for blower motors and drives and wet coil and options/accessory air resistance data.

DOWNFLOW

External Static Press. in. w.g.	Percentage of Total Motor Torque																										
	20%		30%		40%		50%		60%		70%		80%		90%		100%										
	Cfm	RPM	Cfm	RPM	Cfm	RPM	Cfm	RPM	Cfm	RPM	Cfm	RPM	Cfm	RPM	Cfm	RPM	Cfm	RPM	Cfm	RPM							
0	1046	77	485	1257	134	565	1468	191	646	1639	271	715	1810	351	784	1960	445	837	2109	539	890	2251	674	947	2393	810	1004
0.1	992	85	543	1211	145	619	1430	205	695	1609	285	755	1788	365	814	1937	463	870	2086	561	925	2227	691	977	2367	822	1029
0.2	926	95	612	1166	154	669	1405	214	727	1580	299	793	1755	384	859	1909	482	909	2063	581	959	2200	708	1008	2336	835	1056
0.3	883	101	657	1125	164	715	1367	227	774	1551	311	831	1734	396	888	1891	495	934	2048	593	980	2181	719	1028	2314	844	1076
0.4	818	111	724	1074	175	772	1329	240	820	1515	327	875	1701	414	930	1859	515	975	2017	617	1021	2147	737	1064	2276	857	1107
0.5	752	121	791	1022	187	828	1291	253	865	1485	339	911	1679	425	957	1837	529	1003	1994	632	1049	2120	749	1090	2245	866	1131
0.6	---	---	---	---	---	---	1253	265	908	1450	354	952	1646	442	996	1809	544	1036	1972	646	1076	2094	760	1114	2215	873	1153
0.7	---	---	---	---	---	---	1202	282	965	1408	370	999	1613	458	1034	1777	560	1071	1941	662	1109	2063	771	1141	2185	879	1174
0.8	---	---	---	---	---	---	1164	294	1006	1372	383	1038	1580	473	1070	1745	574	1104	1910	676	1138	2025	781	1171	2139	886	1204
0.9	---	---	---	---	---	---	1126	306	1046	1337	396	1075	1548	487	1105	1714	587	1135	1880	687	1165	1987	788	1198	2094	889	1230
1.0	---	---	---	---	---	---	1081	320	1092	1298	410	1115	1515	500	1138	1675	599	1169	1834	699	1200	1941	794	1227	2048	889	1254
1.1	---	---	---	---	---	---	---	---	---	---	---	---	1476	514	1174	1632	609	1201	1788	704	1229	1896	795	1251	2003	886	1274
1.2	---	---	---	---	---	---	---	---	---	---	---	---	---	---	---	---	---	---	1728	702	1256	1835	790	1277	1942	878	1298

HORIZONTAL

External Static Press. in. w.g.	Percentage of Total Motor Torque																										
	20%		30%		40%		50%		60%		70%		80%		90%		100%										
	Cfm	RPM	Cfm	RPM	Cfm	RPM	Cfm	RPM	Cfm	RPM	Cfm	RPM	Cfm	RPM	Cfm	RPM	Cfm	RPM	Cfm	RPM	Cfm	RPM	Cfm	RPM	Cfm	RPM	
0	1023	78	452	1234	131	536	1445	183	621	1611	251	688	1776	319	754	1910	400	800	2043	480	846	2192	613	904	2340	746	963
0.1	970	82	529	1192	137	596	1414	192	664	1586	261	722	1757	330	780	1902	427	837	2048	523	893	2189	640	942	2330	758	991
0.2	909	86	590	1146	144	647	1383	201	705	1553	275	764	1723	349	824	1876	444	873	2028	540	923	2170	659	970	2312	779	1018
0.3	829	95	675	1084	154	718	1339	213	761	1520	287	807	1701	361	853	1853	459	903	2005	557	953	2138	673	1001	2271	789	1049
0.4	772	104	734	1032	165	774	1293	226	814	1477	304	859	1661	382	904	1818	480	949	1975	579	993	2098	690	1039	2222	802	1084
0.5	688	118	818	967	178	841	1247	238	864	1439	317	902	1631	396	940	1787	498	986	1943	599	1032	2066	704	1069	2189	809	1106
0.6	---	---	---	---	---	---	1202	249	910	1400	330	944	1597	411	978	1758	512	1018	1920	613	1059	2035	715	1095	2150	817	1132
0.7	---	---	---	---	---	---	1146	265	967	1355	345	990	1565	426	1014	1727	527	1053	1889	629	1092	1997	726	1125	2105	822	1158
0.8	---	---	---	---	---	---	1085	280	1021	1302	362	1040	1520	443	1060	1685	544	1095	1849	646	1130	1950	737	1160	2051	828	1191
0.9	---	---	---	---	---	---	1029	292	1064	1255	376	1085	1481	460	1106	1643	560	1137	1805	660	1167	1898	745	1194	1991	830	1222
1.0	---	---	---	---	---	---	961	308	1114	1207	389	1126	1456	471	1137	1601	571	1173	1746	672	1209	1836	751	1230	1926	829	1251
1.1	---	---	---	---	---	---	---	---	---	---	---	---	1416	488	1185	1549	581	1213	1682	675	1241	1774	750	1258	1867	824	1276
1.2	---	---	---	---	---	---	---	---	---	---	---	---	---	---	---	---	---	---	1570	652	1268	1675	732	1286	1780	812	1305

BLOWER DATA - LGH DIRECT DRIVE - 5 TON - HIGH EFFICIENCY

BLOWER TABLE INCLUDES RESISTANCE FOR BASE UNIT ONLY WITH DRY INDOOR COIL AND AIR FILTERS IN PLACE. FOR ALL UNITS ADD:

1 - Any factory installed options air resistance (heat section, economizer, etc.).

2 - Any field installed accessories air resistance (duct resistance, diffuser, etc.).

See page 45 for wet coil and options/accessory air resistance data.

NOTE - Default Speed Settings (percentage of blower torque) - Low 36% / High 59%

DOWNFLOW

External Static Press. in. w.g.	Percentage of Total Motor Torque																										
	20%			30%			40%			50%			60%			70%			80%			90%			100%		
	Cfm	Watts	RPM	Cfm	Watts	RPM	Cfm	Watts	RPM	Cfm	Watts	RPM	Cfm	Watts	RPM	Cfm	Watts	RPM	Cfm	Watts	RPM	Cfm	Watts	RPM	Cfm	Watts	RPM
0	1132	79	438	1353	146	524	1575	212	610	1765	300	670	1954	388	730	2126	513	796	2298	638	861	2445	792	913	2591	946	965
0.1	1061	86	494	1305	155	568	1548	223	641	1743	315	702	1937	407	764	2110	531	823	2282	654	883	2426	808	935	2570	963	987
0.2	990	94	550	1253	165	614	1516	236	678	1716	330	735	1916	423	793	2088	549	851	2260	675	910	2405	827	959	2549	979	1009
0.3	920	102	606	1202	175	659	1484	248	713	1687	345	770	1890	442	828	2065	568	882	2239	694	937	2384	844	983	2528	994	1030
0.4	849	111	662	1151	185	705	1452	260	747	1658	360	804	1863	460	861	2041	586	911	2218	713	962	2363	861	1006	2508	1009	1050
0.5	779	121	718	1094	198	754	1410	275	790	1626	374	838	1842	473	886	2020	601	936	2197	730	987	2342	876	1028	2487	1023	1070
0.6	---	---	---	---	---	---	1368	289	830	1589	390	876	1810	492	921	1993	619	966	2176	746	1010	2316	895	1054	2456	1043	1099
0.7	---	---	---	---	---	---	1325	303	868	1552	406	911	1778	509	954	1966	635	993	2154	761	1033	2295	908	1075	2435	1055	1117
0.8	---	---	---	---	---	---	1261	321	920	1504	423	952	1746	524	984	1934	653	1024	2122	782	1064	2268	925	1100	2414	1067	1135
0.9	---	---	---	---	---	---	1211	337	964	1462	437	988	1714	538	1012	1902	669	1053	2090	801	1094	2237	942	1127	2383	1084	1161
1.0	---	---	---	---	---	---	1151	354	1013	1412	454	1029	1672	553	1045	1871	682	1078	2069	811	1112	2211	955	1149	2352	1099	1185
1.1	---	---	---	---	---	---	---	---	---	---	---	---	1629	566	1073	1828	698	1109	2027	830	1146	2174	971	1177	2321	1112	1208
1.2	---	---	---	---	---	---	---	---	---	---	---	---	---	---	---	---	---	---	1984	844	1175	2137	984	1202	2290	1124	1230

HORIZONTAL

External Static Press. in. w.g.	Percentage of Total Motor Torque																										
	20%			30%			40%			50%			60%			70%			80%			90%			100%		
	Cfm	Watts	RPM	Cfm	Watts	RPM	Cfm	Watts	RPM	Cfm	Watts	RPM	Cfm	Watts	RPM	Cfm	Watts	RPM	Cfm	Watts	RPM	Cfm	Watts	RPM	Cfm	Watts	RPM
0	1127	82	426	1367	141	504	1607	200	582	1806	296	644	2005	391	706	2167	495	764	2328	599	822	2463	749	872	2598	899	922
0.1	1071	86	476	1326	148	543	1580	210	610	1781	311	675	1981	411	740	2145	516	795	2309	620	849	2456	775	898	2602	931	947
0.2	1010	91	529	1268	160	598	1525	229	668	1735	332	724	1945	434	781	2117	537	828	2289	640	875	2438	795	921	2587	949	967
0.3	930	100	597	1214	169	647	1497	239	696	1707	345	755	1917	452	814	2093	556	857	2269	660	900	2417	817	948	2565	975	995
0.4	869	109	646	1156	184	699	1442	258	751	1665	364	798	1888	469	845	2066	577	889	2243	685	933	2393	842	978	2543	998	1022
0.5	813	119	689	1114	193	734	1414	267	778	1637	376	827	1860	485	876	2039	597	920	2217	709	963	2373	861	1002	2528	1013	1040
0.6	---	---	---	---	---	---	1358	286	831	1595	394	868	1832	501	905	2012	616	949	2191	731	993	2349	882	1028	2506	1033	1064
0.7	---	---	---	---	---	---	1330	296	857	1560	409	903	1789	523	949	1977	638	985	2164	753	1020	2324	902	1054	2484	1052	1088
0.8	---	---	---	---	---	---	1275	315	908	1518	426	942	1761	536	977	1950	655	1011	2138	773	1046	2296	923	1081	2454	1073	1116
0.9	---	---	---	---	---	---	1233	329	946	1483	439	975	1732	549	1004	1922	670	1037	2112	792	1071	2272	939	1104	2432	1087	1136
1.0	---	---	---	---	---	---	1192	343	982	1441	455	1012	1690	567	1043	1881	692	1074	2072	818	1105	2237	960	1133	2402	1102	1161
1.1	---	---	---	---	---	---	---	---	---	---	---	---	1662	578	1068	1854	706	1097	2046	833	1126	2206	975	1157	2365	1117	1188
1.2	---	---	---	---	---	---	---	---	---	---	---	---	---	---	---	---	---	---	1994	861	1163	2165	993	1185	2336	1125	1206

BLOWER DATA - LCH DIRECT DRIVE - 5 TON - HIGH EFFICIENCY

BLOWER TABLE INCLUDES RESISTANCE FOR BASE UNIT ONLY WITH DRY INDOOR COIL AND AIR FILTERS IN PLACE.

FOR ALL UNITS ADD:

1 - Any factory installed options air resistance (heat section, economizer, etc.).

2 - Any field installed accessories air resistance (duct resistance, diffuser, etc.).

See Page 45 for blower motors and drives and wet coil and options/accessory air resistance data.

DOWNFLOW

External Static Press. in. w.g.	Percentage of Total Motor Torque																												
	20%			30%			40%			50%			60%			70%			80%			90%			100%				
	Cfm	RPM	Watts	Cfm	RPM	Watts	Cfm	RPM	Watts	Cfm	RPM	Watts	Cfm	RPM	Watts	Cfm	RPM	Watts	Cfm	RPM	Watts	Cfm	RPM	Watts	Cfm	RPM	Watts	Cfm	RPM
0	1102	76	420	1324	143	510	1545	211	601	1740	302	667	1934	393	734	2096	519	797	2258	645	860	2396	791	910	2534	938	959	986	1003
0.1	1038	85	484	1284	153	559	1529	221	633	1722	315	698	1914	410	763	2078	535	823	2242	660	882	2378	810	934	2514	960	986	1003	1003
0.2	975	94	546	1235	165	611	1495	236	677	1692	332	737	1888	429	798	2057	553	851	2225	677	905	2363	825	954	2501	973	1003	1003	1003
0.3	911	104	603	1192	175	654	1473	245	706	1672	343	763	1871	441	820	2040	566	874	2208	692	928	2348	839	974	2488	987	1020	1020	1020
0.4	847	114	657	1143	187	702	1439	259	747	1642	359	800	1845	458	852	2015	585	904	2185	712	956	2327	858	1000	2469	1005	1044	1044	1044
0.5	784	124	708	1095	198	747	1406	273	785	1613	374	835	1819	475	884	1994	600	931	2168	726	977	2309	874	1022	2450	1022	1066	1066	1066
0.6	721	134	761	1046	211	792	1372	285	822	1583	388	868	1793	490	915	1969	617	959	2145	743	1004	2288	890	1046	2431	1037	1087	1087	1087
0.7	658	144	814	999	223	833	1339	297	856	1553	401	900	1767	505	944	1945	633	987	2122	760	1029	2267	906	1068	2411	1051	1108	1108	1108
0.8	595	154	864	952	255	874	1294	313	899	1518	416	936	1741	519	973	1920	647	1013	2099	776	1054	2246	920	1090	2392	1064	1127	1127	1127
0.9	532	164	914	900	287	911	1249	327	937	1478	432	974	1706	537	1010	1891	663	1043	2076	790	1077	2221	934	1113	2366	1078	1150	1150	1150
1.0	469	174	964	846	319	948	1193	343	980	1437	446	1008	1680	549	1036	1867	676	1067	2053	803	1098	2200	945	1132	2347	1087	1166	1166	1166
1.1	406	184	1014	791	351	987	1130	355	1019	1376	460	1037	1649	562	1066	1834	691	1097	2019	821	1129	2164	961	1162	2308	1100	1194	1194	1194
1.2	343	194	1064	738	383	1026	1066	367	1048	1305	474	1066	1649	562	1066	1834	691	1097	1984	836	1157	2133	971	1184	2282	1106	1211	1211	1211

HORIZONTAL

External Static Press. in. w.g.	Percentage of Total Motor Torque																												
	20%			30%			40%			50%			60%			70%			80%			90%			100%				
	Cfm	RPM	Watts	Cfm	RPM	Watts	Cfm	RPM	Watts	Cfm	RPM	Watts	Cfm	RPM	Watts	Cfm	RPM	Watts	Cfm	RPM	Watts	Cfm	RPM	Watts	Cfm	RPM	Watts	Cfm	RPM
0	1129	85	418	1343	146	512	1556	208	606	1740	306	679	1923	405	752	2084	530	812	2245	655	872	2377	807	927	2508	959	982	1002	1023
0.1	1063	88	464	1295	154	550	1527	220	635	1715	318	705	1903	417	776	2070	546	835	2237	675	895	2368	823	948	2498	972	1002	1002	1023
0.2	984	95	534	1234	166	607	1483	237	680	1681	335	743	1878	432	807	2046	562	863	2214	691	920	2347	842	971	2479	993	1023	1023	1023
0.3	917	103	606	1178	179	665	1438	255	724	1645	351	780	1852	447	836	2018	580	894	2183	712	952	2321	862	997	2459	1012	1043	1043	1043
0.4	862	112	681	1128	192	725	1393	272	768	1604	370	823	1814	468	878	1987	598	927	2160	728	975	2298	881	1021	2435	1034	1067	1067	1067
0.5	818	124	760	1091	204	779	1364	283	798	1576	383	851	1788	482	905	1963	612	951	2137	742	997	2274	898	1044	2410	1055	1090	1090	1090
0.6	764	134	838	1042	216	811	1319	300	842	1541	398	886	1762	495	931	1934	628	979	2106	761	1026	2244	919	1071	2381	1076	1115	1115	1115
0.7	701	144	902	993	228	842	1274	317	885	1499	415	926	1724	513	967	1900	646	1010	2075	779	1054	2219	934	1093	2362	1089	1131	1131	1131
0.8	638	154	972	944	250	873	1245	328	914	1466	429	957	1686	531	1001	1865	663	1040	2044	796	1080	2188	951	1117	2332	1106	1154	1154	1154
0.9	575	164	1040	896	282	904	1200	344	957	1424	446	995	1647	547	1032	1830	679	1069	2013	812	1105	2154	968	1143	2294	1124	1181	1181	1181
1.0	512	174	1108	848	314	935	1155	360	1000	1382	461	1030	1609	563	1061	1796	695	1095	1983	826	1129	2124	980	1164	2264	1134	1200	1200	1200
1.1	449	184	1176	790	344	966	1100	372	1029	1300	474	1059	1570	577	1087	1753	712	1124	1936	847	1162	2086	994	1189	2235	1141	1216	1216	1216
1.2	386	194	1244	734	374	997	1066	383	1048	1249	487	1087	1500	589	1116	1700	724	1143	1905	859	1182	2041	1003	1213	2176	1146	1244	1244	1244

BLOWER DATA - LGH BELT DRIVE - 3 TON - STANDARD EFFICIENCY

BLOWER TABLE INCLUDES RESISTANCE FOR BASE UNIT ONLY WITH DRY INDOOR COIL AND AIR FILTERS IN PLACE.

FOR ALL UNITS ADD:

1 - Any factory installed options air resistance (heat section, economizer, etc.).

2 - Any field installed accessories air resistance (duct resistance, diffuser, etc.).

See page 45 for blower motors and drives and wet coil and options/accessory air resistance data.

DOWNFLOW

Air Volume (cfm)	External Static (in.w.g.)																			
	0.10		0.20		0.30		0.40		0.50		0.60		0.70		0.80		0.9		1.0	
	RPM	BHP	RPM	BHP	RPM	BHP	RPM	BHP	RPM	BHP	RPM	BHP	RPM	BHP	RPM	BHP	RPM	BHP	RPM	BHP
700	453	0.07	523	0.11	596	0.14	679	0.17	762	0.18	828	0.21	878	0.24	927	0.26	979	0.29	1029	0.31
800	471	0.09	542	0.13	614	0.16	696	0.19	777	0.21	841	0.23	889	0.26	938	0.29	990	0.31	1042	0.34
900	493	0.11	563	0.15	634	0.19	715	0.21	793	0.23	854	0.26	902	0.29	950	0.32	1002	0.34	1054	0.36
1000	517	0.14	587	0.18	657	0.21	736	0.24	811	0.26	869	0.29	916	0.32	964	0.35	1015	0.37	1067	0.4
1100	544	0.17	613	0.21	683	0.24	759	0.27	831	0.3	886	0.32	931	0.36	978	0.38	1028	0.41	1078	0.43
1200	574	0.2	643	0.24	711	0.27	784	0.3	852	0.33	904	0.36	947	0.39	993	0.42	1042	0.45	1091	0.47
1300	608	0.24	676	0.28	743	0.31	812	0.34	875	0.37	923	0.4	964	0.44	1010	0.46	1057	0.49	1104	0.51
1400	645	0.28	711	0.31	776	0.35	842	0.38	898	0.41	942	0.44	983	0.48	1028	0.51	1074	0.53	1120	0.56

Air Volume (cfm)	External Static (in.w.g.)																			
	1.1		1.2		1.3		1.4		1.5		1.6		1.7		1.8		1.9		2.0	
	RPM	BHP	RPM	BHP	RPM	BHP	RPM	BHP	RPM	BHP	RPM	BHP	RPM	BHP	RPM	BHP	RPM	BHP	RPM	BHP
700	1078	0.33	1124	0.36	---	---	---	---	---	---	---	---	---	---	---	---	---	---	---	---
800	1091	0.36	1137	0.39	1180	0.41	1221	0.44	1260	0.47	---	---	---	---	---	---	---	---	---	---
900	1105	0.39	1150	0.42	1192	0.45	1232	0.47	1270	0.5	1307	0.53	1345	0.56	1382	0.59	1420	0.62	---	---
1000	1117	0.42	1162	0.45	1203	0.48	1242	0.51	1279	0.54	1316	0.57	1353	0.6	1390	0.63	1427	0.66	1465	0.7
1100	1126	0.46	1171	0.49	1212	0.52	1251	0.56	1288	0.59	1325	0.62	1361	0.65	1397	0.68	1433	0.71	1470	0.75
1200	1137	0.5	1180	0.54	1222	0.57	1260	0.6	1298	0.64	1334	0.67	1369	0.7	1404	0.73	1440	0.77	1477	0.8
1300	1149	0.55	1191	0.58	1232	0.62	1270	0.65	1307	0.69	1343	0.72	1378	0.76	1413	0.79	1449	0.82	1486	0.86
1400	1163	0.6	1204	0.63	1243	0.67	1281	0.71	1317	0.74	1353	0.78	1388	0.82	1423	0.85	1459	0.89	1496	0.92

BLOWER DATA - LGH BELT DRIVE - 3 TON - STANDARD EFFICIENCY

BLOWER TABLE INCLUDES RESISTANCE FOR BASE UNIT ONLY WITH DRY INDOOR COIL AND AIR FILTERS IN PLACE.

FOR ALL UNITS ADD:

1 - Any factory installed options air resistance (heat section, economizer, etc.).

2 - Any field installed accessories air resistance (duct resistance, diffuser, etc.).

See page 45 for blower motors and drives and wet coil and options/accessory air resistance data.

HORIZONTAL

Air Volume (cfm)	External Static (in.w.g.)																			
	0.10		0.20		0.30		0.40		0.50		0.60		0.70		0.80		0.9		1.0	
	RPM	BHP	RPM	BHP	RPM	BHP	RPM	BHP	RPM	BHP	RPM	BHP	RPM	BHP	RPM	BHP	RPM	BHP	RPM	BHP
700	440	0.07	510	0.1	585	0.12	657	0.14	726	0.17	793	0.2	856	0.23	915	0.25	967	0.28	1016	0.31
800	456	0.08	526	0.11	600	0.14	672	0.16	739	0.19	804	0.22	866	0.25	923	0.28	975	0.31	1025	0.34
900	474	0.1	544	0.13	617	0.16	688	0.18	754	0.21	818	0.24	877	0.27	932	0.3	984	0.33	1034	0.36
1000	495	0.12	565	0.15	637	0.18	707	0.21	771	0.23	832	0.27	889	0.3	943	0.33	993	0.36	1043	0.39
1100	518	0.14	588	0.18	659	0.21	727	0.23	789	0.26	848	0.3	903	0.33	954	0.37	1003	0.4	1052	0.43
1200	544	0.17	613	0.21	682	0.24	748	0.27	809	0.29	866	0.33	918	0.37	967	0.4	1014	0.43	1062	0.46
1300	572	0.21	640	0.24	707	0.27	771	0.3	830	0.33	884	0.37	934	0.41	981	0.44	1027	0.47	1073	0.5
1400	602	0.24	669	0.28	733	0.31	795	0.34	851	0.37	903	0.41	950	0.45	995	0.49	1040	0.52	1086	0.55

Air Volume (cfm)	External Static (in.w.g.)																			
	1.1		1.2		1.3		1.4		1.5		1.6		1.7		1.8		1.9		2.0	
	RPM	BHP	RPM	BHP	RPM	BHP	RPM	BHP	RPM	BHP	RPM	BHP	RPM	BHP	RPM	BHP	RPM	BHP	RPM	BHP
700	1065	0.33	---	---	---	---	---	---	---	---	---	---	---	---	---	---	---	---	---	---
800	1075	0.36	1122	0.39	1164	0.42	1203	0.45	1241	0.47	---	---	---	---	---	---	---	---	---	---
900	1086	0.39	1133	0.42	1174	0.45	1213	0.48	1250	0.51	1286	0.54	1322	0.57	1357	0.6	1392	0.64	---	---
1000	1094	0.43	1142	0.46	1183	0.49	1222	0.52	1259	0.55	1295	0.58	1330	0.62	1365	0.65	1400	0.68	1435	0.71
1100	1102	0.46	1148	0.49	1191	0.53	1230	0.56	1267	0.6	1303	0.63	1338	0.66	1373	0.69	1408	0.73	1444	0.76
1200	1110	0.5	1156	0.53	1198	0.57	1238	0.61	1275	0.64	1311	0.68	1346	0.71	1381	0.74	1416	0.78	1452	0.81
1300	1120	0.54	1164	0.58	1207	0.62	1246	0.65	1283	0.69	1319	0.73	1354	0.76	1389	0.79	1424	0.83	1460	0.86
1400	1131	0.59	1175	0.63	1216	0.67	1255	0.7	1292	0.74	1327	0.78	1362	0.81	1397	0.84	1432	0.88	1468	0.91

BLOWER DATA - LCH BELT DRIVE - 3 TON - STANDARD EFFICIENCY

BLOWER TABLE INCLUDES RESISTANCE FOR BASE UNIT ONLY WITH DRY INDOOR COIL AND AIR FILTERS IN PLACE.

FOR ALL UNITS ADD:

1 - Any factory installed options air resistance (heat section, economizer, etc.).

2 - Any field installed accessories air resistance (duct resistance, diffuser, etc.).

See Page 45 for blower motors and drives and wet coil and options/accessory air resistance data.

DOWNFLOW

Air Volume (cfm)	External Static (in.w.g.)																			
	0.10		0.20		0.30		0.40		0.50		0.60		0.70		0.80		0.9		1.0	
	RPM	BHP	RPM	BHP	RPM	BHP	RPM	BHP	RPM	BHP	RPM	BHP	RPM	BHP	RPM	BHP	RPM	BHP	RPM	BHP
700	447	0.09	517	0.12	589	0.15	663	0.17	739	0.19	815	0.2	883	0.23	938	0.25	988	0.27	1039	0.29
800	465	0.1	534	0.14	605	0.17	678	0.19	753	0.21	825	0.23	890	0.25	946	0.27	996	0.3	1047	0.32
900	486	0.12	554	0.16	623	0.2	695	0.22	767	0.23	836	0.25	897	0.28	953	0.3	1004	0.33	1055	0.35
1000	508	0.15	576	0.19	643	0.22	713	0.24	783	0.26	848	0.28	907	0.3	961	0.33	1011	0.36	1062	0.38
1100	533	0.18	599	0.22	665	0.25	733	0.27	800	0.28	863	0.31	919	0.34	971	0.36	1020	0.39	1070	0.41
1200	560	0.21	625	0.25	689	0.28	755	0.3	820	0.32	879	0.34	932	0.37	983	0.4	1031	0.43	1079	0.45
1300	591	0.24	654	0.28	716	0.31	779	0.33	841	0.35	897	0.38	948	0.41	996	0.44	1044	0.47	1091	0.49
1400	631	0.26	690	0.3	748	0.34	807	0.36	864	0.39	916	0.42	964	0.46	1011	0.49	1058	0.51	1105	0.54

Air Volume (cfm)	External Static (in.w.g.)																			
	1.1		1.2		1.3		1.4		1.5		1.6		1.7		1.8		1.9		2.0	
	RPM	BHP	RPM	BHP	RPM	BHP	RPM	BHP	RPM	BHP	RPM	BHP	RPM	BHP	RPM	BHP	RPM	BHP	RPM	BHP
700	1088	0.31	---	---	---	---	---	---	---	---	---	---	---	---	---	---	---	---	---	---
800	1098	0.34	1144	0.36	1185	0.39	1224	0.42	---	---	---	---	---	---	---	---	---	---	---	---
900	1106	0.37	1152	0.4	1193	0.43	1232	0.46	1269	0.49	1305	0.52	1340	0.55	1376	0.59	---	---	---	---
1000	1111	0.41	1157	0.43	1199	0.47	1238	0.5	1276	0.53	1311	0.56	1347	0.6	1382	0.63	1417	0.67	1452	0.7
1100	1118	0.44	1163	0.47	1206	0.51	1245	0.54	1282	0.58	1318	0.61	1353	0.65	1388	0.68	1423	0.72	1458	0.75
1200	1127	0.48	1171	0.52	1213	0.55	1252	0.59	1289	0.62	1324	0.66	1358	0.7	1393	0.73	1428	0.77	1463	0.81
1300	1137	0.53	1181	0.56	1221	0.6	1259	0.64	1296	0.68	1330	0.71	1364	0.75	1398	0.78	1432	0.82	1467	0.86
1400	1150	0.57	1191	0.61	1231	0.65	1268	0.69	1303	0.73	1337	0.77	1371	0.8	1404	0.84	1437	0.88	1473	0.91

BLOWER DATA - LCH BELT DRIVE - 3 TON - STANDARD EFFICIENCY

BLOWER TABLE INCLUDES RESISTANCE FOR BASE UNIT ONLY WITH DRY INDOOR COIL AND AIR FILTERS IN PLACE.

FOR ALL UNITS ADD:

1 - Any factory installed options air resistance (heat section, economizer, etc.).

2 - Any field installed accessories air resistance (duct resistance, diffuser, etc.).

See Page 45 for blower motors and drives and wet coil and options/accessory air resistance data.

HORIZONTAL

Air Volume (cfm)	External Static (in.w.g.)																			
	0.10		0.20		0.30		0.40		0.50		0.60		0.70		0.80		0.9		1.0	
	RPM	BHP	RPM	BHP	RPM	BHP	RPM	BHP	RPM	BHP	RPM	BHP	RPM	BHP	RPM	BHP	RPM	BHP	RPM	BHP
700	445	0.08	516	0.11	591	0.13	670	0.15	753	0.16	820	0.19	870	0.22	918	0.24	969	0.27	1021	0.29
800	463	0.09	534	0.12	608	0.14	685	0.16	766	0.18	830	0.21	878	0.24	926	0.27	977	0.29	1030	0.32
900	485	0.11	554	0.14	627	0.16	703	0.18	780	0.21	841	0.23	888	0.27	935	0.3	986	0.32	1039	0.35
1000	509	0.13	578	0.16	649	0.19	722	0.21	796	0.23	854	0.26	900	0.29	947	0.33	997	0.35	1048	0.38
1100	537	0.16	605	0.19	674	0.21	744	0.24	813	0.26	868	0.29	913	0.33	959	0.36	1008	0.39	1059	0.41
1200	567	0.19	633	0.22	700	0.24	768	0.27	833	0.3	884	0.33	928	0.37	974	0.4	1022	0.43	1071	0.45
1300	599	0.22	664	0.25	729	0.28	793	0.3	853	0.33	902	0.37	945	0.41	990	0.44	1037	0.47	1085	0.5
1400	634	0.26	697	0.29	758	0.31	819	0.34	875	0.38	921	0.42	964	0.46	1008	0.49	1054	0.52	1100	0.54

Air Volume (cfm)	External Static (in.w.g.)																			
	1.1		1.2		1.3		1.4		1.5		1.6		1.7		1.8		1.9		2.0	
	RPM	BHP	RPM	BHP	RPM	BHP	RPM	BHP	RPM	BHP	RPM	BHP	RPM	BHP	RPM	BHP	RPM	BHP	RPM	BHP
700	1071	0.32	---	---	---	---	---	---	---	---	---	---	---	---	---	---	---	---	---	---
800	1082	0.34	1128	0.37	1169	0.4	1205	0.42	---	---	---	---	---	---	---	---	---	---	---	---
900	1090	0.37	1137	0.4	1177	0.43	1214	0.46	1248	0.49	1280	0.51	1310	0.54	1340	0.57	---	---	---	---
1000	1098	0.41	1143	0.44	1184	0.47	1221	0.5	1255	0.53	1287	0.56	1318	0.59	1347	0.61	1377	0.64	1406	0.67
1100	1107	0.44	1150	0.47	1191	0.51	1228	0.54	1263	0.57	1295	0.6	1325	0.63	1355	0.66	1384	0.69	1413	0.72
1200	1117	0.48	1160	0.52	1200	0.55	1237	0.59	1271	0.62	1303	0.66	1334	0.69	1363	0.72	1392	0.75	1420	0.78
1300	1130	0.53	1171	0.57	1210	0.6	1246	0.64	1280	0.68	1312	0.71	1342	0.74	1372	0.78	1400	0.81	1429	0.84
1400	1144	0.58	1183	0.62	1221	0.66	1256	0.7	1290	0.73	1321	0.77	1352	0.8	1381	0.84	1410	0.87	1439	0.9

BLOWER DATA - LGH BELT DRIVE - 4 TON - STANDARD EFFICIENCY

BLOWER TABLE INCLUDES RESISTANCE FOR BASE UNIT ONLY WITH DRY INDOOR COIL AND AIR FILTERS IN PLACE.

FOR ALL UNITS ADD:

1 - Any factory installed options air resistance (heat section, economizer, etc.).

2 - Any field installed accessories air resistance (duct resistance, diffuser, etc.).

See page 45 for blower motors and drives and wet coil and options/accessory air resistance data.

DOWNFLOW

Air Volume (cfm)	External Static (in.w.g.)																			
	0.10		0.20		0.30		0.40		0.50		0.60		0.70		0.80		0.9		1.0	
	RPM	BHP	RPM	BHP	RPM	BHP	RPM	BHP	RPM	BHP	RPM	BHP	RPM	BHP	RPM	BHP	RPM	BHP	RPM	BHP
900	502	0.12	573	0.15	644	0.19	725	0.22	802	0.24	861	0.26	908	0.29	957	0.32	1009	0.34	1061	0.37
1000	528	0.14	598	0.18	668	0.22	747	0.24	821	0.27	877	0.3	923	0.33	971	0.35	1022	0.38	1074	0.4
1100	557	0.17	626	0.21	695	0.25	772	0.28	841	0.3	894	0.33	939	0.36	986	0.39	1037	0.41	1087	0.44
1200	589	0.21	657	0.25	725	0.28	798	0.31	864	0.33	913	0.37	956	0.4	1003	0.43	1052	0.45	1100	0.48
1300	625	0.25	692	0.28	759	0.32	827	0.34	887	0.37	933	0.41	975	0.44	1021	0.47	1068	0.49	1115	0.52
1400	665	0.29	730	0.32	794	0.35	857	0.38	911	0.42	953	0.45	995	0.49	1040	0.52	1086	0.54	1131	0.57
1500	706	0.33	768	0.36	829	0.39	886	0.43	934	0.46	974	0.5	1015	0.54	1060	0.56	1105	0.59	1149	0.62
1600	746	0.37	805	0.4	862	0.44	914	0.48	957	0.52	996	0.55	1037	0.59	1081	0.62	1126	0.64	1167	0.68
1700	784	0.42	840	0.45	893	0.49	940	0.53	980	0.57	1019	0.61	1060	0.64	1104	0.67	1147	0.7	1187	0.74
1800	821	0.47	874	0.51	923	0.55	967	0.59	1006	0.63	1044	0.67	1085	0.7	1128	0.73	1170	0.77	1208	0.82
1900	857	0.53	906	0.57	952	0.62	994	0.66	1032	0.7	1071	0.73	1112	0.76	1154	0.8	1194	0.85	1230	0.9
Air Volume (cfm)	External Static (in.w.g.)																			
	1.1		1.2		1.3		1.4		1.5		1.6		1.7		1.8		1.9		2.0	
	RPM	BHP	RPM	BHP	RPM	BHP	RPM	BHP	RPM	BHP	RPM	BHP	RPM	BHP	RPM	BHP	RPM	BHP	RPM	BHP
900	1111	0.39	1156	0.42	1197	0.45	1236	0.48	1275	0.51	1312	0.54	1349	0.56	1387	0.59	1424	0.62	---	---
1000	1124	0.43	1168	0.46	1209	0.49	1247	0.52	1285	0.55	1322	0.58	1358	0.61	1395	0.64	1432	0.67	1470	0.7
1100	1134	0.47	1178	0.5	1219	0.53	1258	0.56	1295	0.6	1331	0.63	1367	0.66	1403	0.69	1439	0.72	1477	0.75
1200	1146	0.51	1189	0.54	1230	0.58	1268	0.61	1305	0.65	1341	0.68	1376	0.71	1411	0.74	1447	0.77	1485	0.81
1300	1159	0.55	1201	0.59	1241	0.63	1279	0.66	1315	0.7	1351	0.73	1386	0.77	1421	0.8	1457	0.83	1495	0.87
1400	1173	0.61	1214	0.64	1253	0.68	1290	0.72	1327	0.75	1362	0.79	1397	0.82	1432	0.86	1468	0.89	1506	0.93
1500	1189	0.66	1228	0.7	1266	0.74	1303	0.78	1339	0.81	1374	0.85	1409	0.89	1445	0.92	1481	0.96	1519	1
1600	1206	0.72	1244	0.76	1281	0.8	1317	0.84	1353	0.88	1388	0.92	1423	0.96	1459	1	1496	1.04	1535	1.08
1700	1224	0.79	1261	0.83	1298	0.87	1334	0.91	1369	0.95	1404	0.99	1440	1.03	1476	1.07	1513	1.12	1552	1.16
1800	1244	0.86	1280	0.91	1316	0.95	1352	0.99	1387	1.03	1422	1.07	1457	1.11	1494	1.16	1532	1.2	1570	1.24
1900	1265	0.95	1301	1	1336	1.04	1371	1.08	1406	1.12	1441	1.16	1477	1.2	1515	1.24	1553	1.29	1592	1.33

BLOWER DATA - LGH BELT DRIVE - 4 TON - STANDARD EFFICIENCY

BLOWER TABLE INCLUDES RESISTANCE FOR BASE UNIT ONLY WITH DRY INDOOR COIL AND AIR FILTERS IN PLACE.

FOR ALL UNITS ADD:

1 - Any factory installed options air resistance (heat section, economizer, etc.).

2 - Any field installed accessories air resistance (duct resistance, diffuser, etc.).

See page 45 for blower motors and drives and wet coil and options/accessory air resistance data.

HORIZONTAL

Air Volume (cfm)	External Static (in.w.g.)																			
	0.10		0.20		0.30		0.40		0.50		0.60		0.70		0.80		0.9		1.0	
	RPM	BHP	RPM	BHP	RPM	BHP	RPM	BHP	RPM	BHP	RPM	BHP	RPM	BHP	RPM	BHP	RPM	BHP	RPM	BHP
900	483	0.1	554	0.13	627	0.16	699	0.19	765	0.22	826	0.24	882	0.27	935	0.3	986	0.33	1039	0.36
1000	505	0.12	576	0.16	648	0.19	719	0.21	784	0.24	842	0.27	896	0.3	947	0.33	998	0.37	1050	0.4
1100	530	0.15	601	0.18	671	0.21	741	0.24	804	0.27	860	0.3	912	0.34	961	0.37	1010	0.4	1060	0.43
1200	558	0.18	627	0.22	696	0.25	764	0.28	824	0.3	878	0.34	928	0.37	975	0.41	1023	0.44	1072	0.47
1300	588	0.22	656	0.25	723	0.28	788	0.31	846	0.34	897	0.38	945	0.42	990	0.45	1037	0.48	1084	0.51
1400	621	0.25	687	0.29	752	0.32	814	0.35	868	0.38	916	0.42	962	0.46	1006	0.5	1052	0.53	1098	0.56
1500	655	0.29	719	0.33	781	0.36	839	0.39	890	0.43	936	0.47	979	0.51	1023	0.55	1068	0.58	1113	0.61
1600	690	0.33	751	0.37	810	0.4	865	0.44	912	0.48	955	0.52	997	0.56	1041	0.6	1086	0.63	1129	0.66
1700	725	0.38	784	0.41	839	0.45	891	0.49	935	0.53	975	0.58	1017	0.62	1060	0.65	1104	0.68	1147	0.72
1800	761	0.42	816	0.46	868	0.5	916	0.55	957	0.59	997	0.64	1038	0.68	1081	0.71	1124	0.74	1165	0.79
1900	795	0.48	848	0.52	897	0.56	942	0.61	981	0.66	1020	0.7	1060	0.74	1103	0.77	1145	0.81	1183	0.85

Air Volume (cfm)	External Static (in.w.g.)																			
	1.1		1.2		1.3		1.4		1.5		1.6		1.7		1.8		1.9		2.0	
	RPM	BHP	RPM	BHP	RPM	BHP	RPM	BHP	RPM	BHP	RPM	BHP	RPM	BHP	RPM	BHP	RPM	BHP	RPM	BHP
900	1091	0.4	1138	0.43	1180	0.46	1220	0.49	1257	0.53	1293	0.56	1329	0.59	1364	0.62	1400	0.65	1435	0.69
1000	1101	0.43	1149	0.46	1190	0.5	1229	0.53	1266	0.57	1302	0.6	1338	0.63	1373	0.66	1408	0.7	1444	0.73
1100	1110	0.46	1156	0.5	1199	0.54	1238	0.57	1275	0.61	1311	0.64	1346	0.67	1381	0.71	1416	0.74	1452	0.78
1200	1119	0.5	1165	0.54	1207	0.58	1247	0.62	1284	0.65	1319	0.69	1355	0.72	1389	0.75	1425	0.79	1460	0.82
1300	1130	0.55	1175	0.59	1216	0.63	1255	0.66	1292	0.7	1328	0.74	1363	0.77	1398	0.8	1433	0.84	1469	0.87
1400	1143	0.6	1186	0.63	1226	0.67	1265	0.71	1302	0.75	1337	0.79	1372	0.82	1406	0.85	1441	0.89	1477	0.93
1500	1156	0.65	1198	0.69	1237	0.73	1275	0.77	1311	0.8	1346	0.84	1381	0.88	1415	0.91	1450	0.95	1486	0.98
1600	1171	0.7	1211	0.74	1249	0.78	1286	0.82	1321	0.86	1356	0.9	1390	0.93	1425	0.97	1460	1.01	1496	1.05
1700	1186	0.76	1225	0.8	1262	0.84	1298	0.88	1333	0.92	1367	0.96	1401	1	1436	1.03	1471	1.07	1507	1.12
1800	1202	0.83	1240	0.87	1276	0.91	1311	0.95	1345	0.99	1380	1.03	1413	1.07	1448	1.11	1483	1.15	1520	1.19
1900	1220	0.9	1256	0.94	1291	0.99	1326	1.03	1360	1.07	1393	1.1	1427	1.14	1462	1.18	1497	1.22	1534	1.27

BLOWER DATA - LCH BELT DRIVE - 4 TON - STANDARD EFFICIENCY

BLOWER TABLE INCLUDES RESISTANCE FOR BASE UNIT ONLY WITH DRY INDOOR COIL AND AIR FILTERS IN PLACE.

FOR ALL UNITS ADD:

1 - Any factory installed options air resistance (heat section, economizer, etc.).

2 - Any field installed accessories air resistance (duct resistance, diffuser, etc.).

See Page 45 for blower motors and drives and wet coil and options/accessory air resistance data.

DOWNFLOW

Air Volume (cfm)	External Static (in.w.g.)																			
	0.10		0.20		0.30		0.40		0.50		0.60		0.70		0.80		0.9		1.0	
	RPM	BHP	RPM	BHP	RPM	BHP	RPM	BHP	RPM	BHP	RPM	BHP	RPM	BHP	RPM	BHP	RPM	BHP	RPM	BHP
900	496	0.13	568	0.16	640	0.18	711	0.2	779	0.22	844	0.25	905	0.28	960	0.3	1010	0.33	1061	0.35
1000	521	0.15	592	0.18	662	0.2	731	0.23	796	0.25	858	0.28	916	0.31	969	0.34	1019	0.36	1069	0.38
1100	548	0.18	618	0.21	686	0.23	752	0.25	814	0.28	873	0.31	929	0.34	980	0.37	1029	0.39	1078	0.42
1200	577	0.21	646	0.24	712	0.26	775	0.29	834	0.31	890	0.35	943	0.38	993	0.41	1041	0.43	1089	0.46
1300	611	0.24	677	0.27	740	0.3	800	0.32	856	0.35	909	0.39	959	0.42	1007	0.45	1055	0.47	1102	0.5
1400	654	0.26	713	0.29	771	0.33	826	0.36	878	0.39	928	0.43	976	0.47	1023	0.49	1070	0.52	1117	0.55
1500	698	0.28	751	0.32	802	0.36	852	0.4	901	0.44	948	0.48	995	0.51	1041	0.54	1088	0.57	1133	0.6
1600	738	0.32	785	0.36	831	0.41	878	0.45	923	0.49	969	0.53	1014	0.57	1061	0.59	1107	0.62	1151	0.66
1700	773	0.36	816	0.41	859	0.46	903	0.51	947	0.55	991	0.58	1036	0.62	1082	0.65	1128	0.68	1169	0.72
1800	803	0.42	844	0.47	886	0.52	929	0.57	972	0.61	1016	0.64	1060	0.68	1106	0.71	1150	0.74	1189	0.79
1900	831	0.48	872	0.54	915	0.59	957	0.63	1000	0.67	1043	0.71	1087	0.74	1131	0.78	1173	0.81	1208	0.86

Air Volume (cfm)	External Static (in.w.g.)																			
	1.1		1.2		1.3		1.4		1.5		1.6		1.7		1.8		1.9		2.0	
	RPM	BHP	RPM	BHP	RPM	BHP	RPM	BHP	RPM	BHP	RPM	BHP	RPM	BHP	RPM	BHP	RPM	BHP	RPM	BHP
900	1112	0.38	1157	0.4	1198	0.43	1236	0.46	1273	0.49	1309	0.52	1344	0.56	1380	0.59	---	---	---	---
1000	1119	0.41	1164	0.44	1206	0.47	1244	0.5	1281	0.54	1317	0.57	1352	0.6	1387	0.64	1422	0.67	1458	0.71
1100	1126	0.45	1171	0.48	1213	0.51	1252	0.55	1288	0.58	1324	0.62	1359	0.65	1394	0.69	1429	0.72	1464	0.76
1200	1136	0.49	1180	0.52	1221	0.56	1259	0.6	1296	0.63	1331	0.67	1365	0.7	1400	0.74	1435	0.78	1471	0.81
1300	1148	0.53	1190	0.57	1230	0.61	1268	0.65	1304	0.68	1338	0.72	1372	0.76	1406	0.79	1440	0.83	1476	0.87
1400	1161	0.58	1202	0.62	1240	0.66	1277	0.7	1312	0.74	1346	0.78	1379	0.81	1412	0.85	1446	0.89	1482	0.92
1500	1175	0.64	1214	0.68	1252	0.72	1287	0.76	1321	0.8	1355	0.83	1387	0.87	1420	0.91	1454	0.95	1490	0.99
1600	1190	0.7	1228	0.74	1264	0.78	1298	0.82	1332	0.86	1364	0.9	1397	0.93	1430	0.97	1464	1.01	1499	1.06
1700	1206	0.76	1242	0.8	1277	0.84	1310	0.88	1343	0.92	1375	0.96	1407	1	1440	1.04	1475	1.09	1510	1.13
1800	1223	0.83	1257	0.87	1291	0.91	1324	0.95	1356	0.99	1388	1.03	1420	1.08	1453	1.12	1487	1.16	1523	1.21
1900	1240	0.91	1273	0.95	1306	0.99	1338	1.03	1369	1.07	1401	1.12	1433	1.16	1467	1.2	1501	1.25	1537	1.29

BLOWER DATA - LCH BELT DRIVE - 4 TON - STANDARD EFFICIENCY

BLOWER TABLE INCLUDES RESISTANCE FOR BASE UNIT ONLY WITH DRY INDOOR COIL AND AIR FILTERS IN PLACE.

FOR ALL UNITS ADD:

1 - Any factory installed options air resistance (heat section, economizer, etc.).

2 - Any field installed accessories air resistance (duct resistance, diffuser, etc.).

See Page 45 for blower motors and drives and wet coil and options/accessory air resistance data.

HORIZONTAL

Air Volume (cfm)	External Static (in.w.g.)																			
	0.10		0.20		0.30		0.40		0.50		0.60		0.70		0.80		0.9		1.0	
	RPM	BHP	RPM	BHP	RPM	BHP	RPM	BHP	RPM	BHP	RPM	BHP	RPM	BHP	RPM	BHP	RPM	BHP	RPM	BHP
900	493	0.12	564	0.14	637	0.17	712	0.19	788	0.21	847	0.24	894	0.27	942	0.3	993	0.33	1046	0.35
1000	520	0.14	589	0.17	660	0.19	733	0.21	805	0.24	861	0.27	907	0.3	954	0.33	1004	0.36	1056	0.38
1100	549	0.16	617	0.19	686	0.22	756	0.24	823	0.27	876	0.3	921	0.33	968	0.37	1017	0.39	1067	0.42
1200	582	0.19	648	0.22	714	0.25	781	0.27	843	0.3	893	0.34	938	0.37	984	0.41	1032	0.43	1081	0.46
1300	624	0.22	686	0.25	747	0.28	808	0.31	865	0.34	912	0.38	956	0.42	1001	0.45	1048	0.48	1096	0.5
1400	670	0.24	726	0.27	782	0.31	837	0.35	887	0.39	932	0.43	975	0.47	1020	0.5	1066	0.52	1112	0.55
1500	714	0.26	765	0.31	814	0.35	863	0.39	910	0.44	953	0.48	996	0.52	1041	0.55	1086	0.58	1130	0.61
1600	752	0.3	798	0.35	844	0.4	889	0.45	933	0.49	975	0.53	1018	0.57	1062	0.6	1107	0.63	1149	0.67
1700	785	0.35	827	0.4	871	0.46	914	0.51	957	0.55	999	0.59	1042	0.63	1085	0.66	1129	0.69	1169	0.73
1800	813	0.42	855	0.47	898	0.52	940	0.57	983	0.62	1025	0.66	1067	0.69	1110	0.72	1152	0.76	1190	0.8
1900	841	0.49	883	0.54	926	0.6	969	0.65	1011	0.69	1052	0.72	1094	0.76	1136	0.79	1176	0.83	1212	0.89

Air Volume (cfm)	External Static (in.w.g.)																			
	1.1		1.2		1.3		1.4		1.5		1.6		1.7		1.8		1.9		2.0	
	RPM	BHP	RPM	BHP	RPM	BHP	RPM	BHP	RPM	BHP	RPM	BHP	RPM	BHP	RPM	BHP	RPM	BHP	RPM	BHP
900	1097	0.38	1142	0.41	1182	0.43	1218	0.46	1252	0.49	1284	0.52	1314	0.55	1344	0.57	---	---	---	---
1000	1105	0.41	1149	0.44	1190	0.47	1226	0.5	1260	0.53	1292	0.56	1322	0.59	1352	0.62	1381	0.65	1410	0.68
1100	1115	0.45	1158	0.48	1198	0.51	1235	0.55	1269	0.58	1301	0.61	1331	0.64	1360	0.67	1389	0.7	1418	0.73
1200	1126	0.49	1168	0.53	1208	0.56	1244	0.6	1278	0.63	1309	0.66	1340	0.69	1369	0.72	1398	0.75	1426	0.78
1300	1140	0.54	1180	0.57	1218	0.61	1254	0.65	1287	0.68	1319	0.72	1349	0.75	1378	0.78	1407	0.81	1436	0.84
1400	1154	0.59	1193	0.63	1230	0.67	1265	0.7	1298	0.74	1330	0.78	1360	0.81	1389	0.85	1418	0.88	1447	0.91
1500	1170	0.65	1208	0.69	1244	0.73	1278	0.77	1310	0.8	1341	0.84	1371	0.88	1401	0.91	1430	0.95	1459	0.98
1600	1187	0.71	1223	0.75	1258	0.79	1291	0.83	1323	0.87	1354	0.91	1384	0.95	1414	0.99	1443	1.02	1474	1.06
1700	1204	0.78	1240	0.82	1274	0.86	1306	0.9	1338	0.95	1369	0.99	1399	1.03	1429	1.06	1459	1.1	1490	1.14
1800	1223	0.85	1258	0.9	1291	0.94	1323	0.99	1354	1.03	1385	1.07	1415	1.11	1445	1.15	1476	1.19	1507	1.23
1900	1243	0.94	1277	0.99	1309	1.03	1341	1.08	1372	1.12	1402	1.16	1433	1.2	1464	1.24	1495	1.28	1527	1.32

BLOWER DATA - BELT DRIVE - 5 TON

BLOWER TABLE INCLUDES RESISTANCE FOR BASE UNIT ONLY WITH DRY INDOOR COIL AND AIR FILTERS IN PLACE.

FOR ALL UNITS ADD:

1 - Any factory installed options air resistance (heat section, economizer, etc.).

2 - Any field installed accessories air resistance (duct resistance, diffuser, etc.).

See page 45 for blower motors and drives and wet coil and options/accessory air resistance data.

DOWNFLOW

Air Volume (cfm)	External Static (in.w.g.)																			
	0.10		0.20		0.30		0.40		0.50		0.60		0.70		0.80		0.9		1.0	
	RPM	BHP	RPM	BHP	RPM	BHP	RPM	BHP	RPM	BHP	RPM	BHP	RPM	BHP	RPM	BHP	RPM	BHP	RPM	BHP
1100	529	0.17	591	0.21	653	0.24	724	0.26	810	0.26	886	0.26	942	0.28	982	0.32	1022	0.36	1064	0.40
1200	553	0.20	615	0.24	677	0.27	747	0.30	829	0.30	902	0.30	955	0.33	994	0.36	1034	0.40	1075	0.44
1300	579	0.23	640	0.27	701	0.31	770	0.33	850	0.34	918	0.35	969	0.37	1007	0.41	1047	0.45	1088	0.49
1400	609	0.27	669	0.31	729	0.34	796	0.37	871	0.38	936	0.39	983	0.41	1022	0.45	1061	0.49	1102	0.53
1500	658	0.28	715	0.32	771	0.36	832	0.39	898	0.41	955	0.43	999	0.46	1037	0.50	1077	0.54	1117	0.58
1600	720	0.28	769	0.33	819	0.37	871	0.41	926	0.44	975	0.47	1016	0.51	1054	0.55	1093	0.60	1133	0.63
1700	779	0.30	822	0.35	864	0.39	908	0.44	953	0.48	995	0.52	1034	0.57	1072	0.61	1111	0.65	1150	0.69
1800	828	0.34	864	0.39	901	0.43	938	0.48	977	0.53	1015	0.58	1053	0.63	1091	0.67	1130	0.71	1169	0.75
1900	857	0.41	892	0.45	927	0.50	962	0.55	999	0.60	1036	0.65	1074	0.69	1112	0.73	1150	0.77	1188	0.81
2000	879	0.47	913	0.52	948	0.56	984	0.61	1020	0.67	1058	0.72	1096	0.76	1134	0.80	1172	0.84	1210	0.88
2100	900	0.53	935	0.58	970	0.63	1007	0.69	1044	0.74	1081	0.79	1119	0.84	1157	0.88	1195	0.91	1233	0.95
2200	922	0.60	958	0.65	994	0.71	1031	0.76	1068	0.82	1106	0.87	1143	0.91	1180	0.95	1218	0.99	1255	1.03
2300	947	0.67	983	0.73	1020	0.79	1057	0.85	1094	0.90	1131	0.95	1168	1.00	1205	1.03	1242	1.07	1277	1.13
2400	974	0.76	1010	0.82	1047	0.88	1084	0.94	1120	0.99	1157	1.04	1193	1.08	1230	1.12	1267	1.16	1300	1.23

Air Volume (cfm)	External Static (in.w.g.)																			
	1.1		1.2		1.3		1.4		1.5		1.6		1.7		1.8		1.9		2.0	
	RPM	BHP	RPM	BHP	RPM	BHP	RPM	BHP	RPM	BHP	RPM	BHP	RPM	BHP	RPM	BHP	RPM	BHP	RPM	BHP
1100	1106	0.44	1151	0.47	1197	0.49	1238	0.52	1272	0.56	---	---	---	---	---	---	---	---	---	---
1200	1117	0.48	1161	0.51	1206	0.53	1245	0.57	1278	0.60	1312	0.64	1346	0.67	1380	0.71	---	---	---	---
1300	1129	0.52	1172	0.55	1216	0.58	1254	0.61	1287	0.65	1320	0.69	1354	0.72	1388	0.76	1421	0.79	1455	0.82
1400	1143	0.57	1185	0.60	1227	0.63	1264	0.66	1296	0.70	1329	0.74	1363	0.77	1397	0.81	1430	0.85	1464	0.88
1500	1157	0.62	1199	0.65	1239	0.68	1275	0.71	1306	0.75	1339	0.79	1373	0.83	1406	0.87	1440	0.90	1473	0.94
1600	1173	0.67	1214	0.70	1253	0.73	1288	0.77	1318	0.81	1351	0.85	1384	0.89	1417	0.93	1451	0.96	1484	1.00
1700	1190	0.72	1230	0.76	1268	0.79	1301	0.83	1331	0.87	1363	0.92	1396	0.95	1429	0.99	1462	1.03	1495	1.07
1800	1208	0.78	1247	0.82	1285	0.86	1317	0.90	1345	0.94	1377	0.98	1410	1.02	1442	1.06	1475	1.10	1508	1.14
1900	1227	0.85	1267	0.88	1303	0.92	1333	0.97	1360	1.02	1392	1.06	1424	1.10	1457	1.14	1489	1.18	1522	1.22
2000	1248	0.92	1286	0.96	1321	1.00	1350	1.05	1377	1.10	1409	1.14	1441	1.18	1473	1.22	1505	1.26	1537	1.30
2100	1269	1.00	1306	1.04	1339	1.09	1367	1.14	1395	1.19	1426	1.23	1458	1.27	1490	1.31	1522	1.35	1554	1.39
2200	1290	1.09	1324	1.14	1356	1.19	1385	1.24	1413	1.28	1444	1.32	1476	1.36	1508	1.41	1540	1.45	1572	1.49
2300	1310	1.20	1343	1.26	1374	1.30	1403	1.34	1432	1.38	1464	1.42	1495	1.46	1527	1.51	1559	1.55	1591	1.59
2400	1332	1.31	1364	1.37	1394	1.41	1423	1.45	1453	1.48	1484	1.53	1516	1.57	1547	1.61	1579	1.65	1612	1.70

BLOWER DATA - LGH BELT DRIVE - 5 TON - STANDARD EFFICIENCY

BLOWER TABLE INCLUDES RESISTANCE FOR BASE UNIT ONLY WITH DRY INDOOR COIL AND AIR FILTERS IN PLACE.

FOR ALL UNITS ADD:

1 - Any factory installed options air resistance (heat section, economizer, etc.).

2 - Any field installed accessories air resistance (duct resistance, diffuser, etc.).

See page 45 for blower motors and drives and wet coil and options/accessory air resistance data.

HORIZONTAL

Air Volume (cfm)	External Static (in.w.g.)																			
	0.10		0.20		0.30		0.40		0.50		0.60		0.70		0.80		0.9		1.0	
	RPM	BHP	RPM	BHP	RPM	BHP	RPM	BHP	RPM	BHP	RPM	BHP	RPM	BHP	RPM	BHP	RPM	BHP	RPM	BHP
1100	503	0.14	569	0.17	636	0.20	703	0.23	769	0.26	842	0.28	909	0.30	964	0.33	1008	0.36	1049	0.40
1200	525	0.16	590	0.20	657	0.23	722	0.26	787	0.29	857	0.31	921	0.34	974	0.37	1016	0.40	1056	0.43
1300	548	0.19	613	0.23	679	0.26	743	0.29	806	0.32	873	0.35	934	0.37	984	0.41	1026	0.44	1065	0.47
1400	574	0.22	638	0.26	702	0.30	765	0.33	827	0.36	891	0.39	949	0.41	996	0.45	1037	0.48	1076	0.51
1500	609	0.25	671	0.29	733	0.33	793	0.36	851	0.39	911	0.42	965	0.46	1010	0.49	1049	0.53	1088	0.56
1600	654	0.28	712	0.32	769	0.36	825	0.39	879	0.43	933	0.47	982	0.50	1024	0.54	1063	0.58	1101	0.61
1700	703	0.31	756	0.35	807	0.39	858	0.43	906	0.47	955	0.51	999	0.55	1039	0.59	1078	0.63	1117	0.66
1800	752	0.34	798	0.38	844	0.43	889	0.48	933	0.52	977	0.57	1017	0.61	1056	0.65	1094	0.68	1133	0.72
1900	796	0.38	837	0.43	878	0.48	918	0.53	958	0.58	997	0.62	1036	0.67	1074	0.71	1112	0.74	1151	0.77
2000	833	0.43	870	0.48	907	0.54	943	0.59	980	0.64	1018	0.69	1055	0.73	1093	0.77	1131	0.80	1170	0.83
2100	864	0.50	897	0.55	931	0.60	966	0.65	1002	0.71	1038	0.76	1075	0.80	1113	0.83	1151	0.87	1189	0.90
2200	887	0.57	920	0.62	953	0.67	988	0.73	1024	0.78	1060	0.83	1097	0.87	1135	0.90	1173	0.94	1210	0.98
2300	909	0.64	942	0.70	976	0.75	1011	0.81	1046	0.86	1083	0.91	1120	0.95	1157	0.98	1195	1.02	1231	1.06
2400	931	0.72	965	0.78	999	0.83	1035	0.89	1071	0.94	1108	0.99	1144	1.03	1181	1.07	1217	1.10	1252	1.15

Air Volume (cfm)	External Static (in.w.g.)																			
	1.1		1.2		1.3		1.4		1.5		1.6		1.7		1.8		1.9		2.0	
	RPM	BHP	RPM	BHP	RPM	BHP	RPM	BHP	RPM	BHP	RPM	BHP	RPM	BHP	RPM	BHP	RPM	BHP	RPM	BHP
1100	1090	0.42	1132	0.45	1175	0.47	1216	0.50	1257	0.53	1296	0.56	1334	0.59	1370	0.62	1405	0.65	1439	0.69
1200	1097	0.46	1139	0.49	1181	0.51	1222	0.54	1263	0.57	1301	0.60	1338	0.63	1374	0.67	1409	0.70	1443	0.74
1300	1106	0.50	1147	0.53	1189	0.55	1230	0.58	1270	0.61	1307	0.65	1344	0.68	1379	0.72	1414	0.75	1447	0.79
1400	1116	0.54	1157	0.57	1198	0.60	1239	0.63	1278	0.66	1315	0.70	1351	0.74	1385	0.77	1419	0.81	1452	0.85
1500	1128	0.59	1168	0.62	1209	0.64	1249	0.68	1287	0.71	1323	0.75	1358	0.79	1393	0.83	1426	0.87	1458	0.91
1600	1141	0.64	1181	0.67	1222	0.70	1261	0.73	1298	0.77	1333	0.81	1367	0.85	1401	0.89	1433	0.93	1465	0.97
1700	1156	0.69	1196	0.72	1235	0.75	1273	0.79	1309	0.83	1344	0.87	1377	0.91	1410	0.96	1442	1.00	1473	1.04
1800	1172	0.75	1211	0.78	1250	0.81	1287	0.85	1322	0.90	1355	0.94	1388	0.98	1420	1.02	1451	1.07	1482	1.11
1900	1190	0.81	1228	0.84	1265	0.88	1301	0.92	1335	0.97	1367	1.01	1399	1.05	1431	1.10	1462	1.14	1492	1.18
2000	1208	0.87	1245	0.91	1281	0.96	1316	1.00	1349	1.04	1380	1.09	1412	1.13	1443	1.18	1473	1.22	1503	1.26
2100	1227	0.94	1263	0.99	1298	1.04	1331	1.08	1363	1.13	1394	1.17	1425	1.22	1455	1.26	1485	1.31	1515	1.35
2200	1246	1.02	1281	1.07	1315	1.12	1347	1.17	1379	1.22	1409	1.26	1439	1.31	1469	1.36	1499	1.40	1529	1.45
2300	1266	1.11	1300	1.16	1333	1.22	1364	1.27	1395	1.32	1424	1.36	1454	1.41	1484	1.46	1513	1.50	1543	1.55
2400	1286	1.20	1319	1.26	1351	1.32	1382	1.38	1411	1.43	1440	1.48	1470	1.52	1499	1.57	1528	1.61	1558	1.66

BLOWER DATA - LCH BELT DRIVE - 5 TON - HIGH EFFICIENCY

BLOWER TABLE INCLUDES RESISTANCE FOR BASE UNIT ONLY WITH DRY INDOOR COIL AND AIR FILTERS IN PLACE.

FOR ALL UNITS ADD:

1 - Any factory installed options air resistance (heat section, economizer, etc.).

2 - Any field installed accessories air resistance (duct resistance, diffuser, etc.).

See Page 45 for blower motors and drives and wet coil and options/accessory air resistance data.

DOWNFLOW

Air Volume (cfm)	External Static (in.w.g.)																			
	0.10		0.20		0.30		0.40		0.50		0.60		0.70		0.80		0.9		1.0	
	RPM	BHP	RPM	BHP	RPM	BHP	RPM	BHP	RPM	BHP	RPM	BHP	RPM	BHP	RPM	BHP	RPM	BHP	RPM	BHP
1100	512	0.15	571	0.19	630	0.23	690	0.26	770	0.26	854	0.26	922	0.27	970	0.30	1006	0.35	1045	0.39
1200	535	0.18	593	0.22	651	0.26	710	0.29	788	0.30	868	0.30	933	0.31	978	0.34	1013	0.38	1053	0.42
1300	559	0.22	616	0.26	674	0.29	732	0.32	807	0.34	883	0.34	944	0.35	987	0.38	1022	0.42	1062	0.46
1400	584	0.26	641	0.29	698	0.33	755	0.36	827	0.37	899	0.38	956	0.40	997	0.43	1033	0.47	1072	0.51
1500	615	0.29	671	0.33	726	0.36	782	0.39	850	0.41	917	0.42	970	0.44	1009	0.47	1045	0.52	1085	0.56
1600	665	0.30	716	0.34	768	0.38	819	0.41	879	0.44	937	0.46	985	0.49	1022	0.52	1059	0.57	1098	0.61
1700	723	0.31	768	0.35	814	0.39	860	0.43	910	0.47	959	0.50	1001	0.54	1037	0.58	1074	0.62	1113	0.66
1800	779	0.32	818	0.37	857	0.41	897	0.46	939	0.50	980	0.55	1018	0.59	1054	0.64	1091	0.68	1129	0.72
1900	826	0.36	859	0.41	894	0.45	928	0.50	964	0.56	1000	0.61	1036	0.66	1072	0.70	1109	0.75	1146	0.79
2000	857	0.42	889	0.47	920	0.52	952	0.57	986	0.62	1020	0.68	1055	0.73	1091	0.77	1128	0.82	1164	0.86
2100	878	0.49	909	0.54	940	0.59	973	0.64	1006	0.70	1041	0.75	1076	0.80	1112	0.85	1148	0.89	1185	0.93
2200	897	0.55	929	0.61	961	0.66	994	0.72	1028	0.78	1063	0.83	1099	0.89	1134	0.93	1170	0.97	1206	1.01
2300	918	0.62	950	0.68	983	0.74	1017	0.80	1052	0.86	1087	0.92	1122	0.97	1157	1.02	1193	1.06	1228	1.09
2400	941	0.70	974	0.77	1008	0.83	1042	0.90	1077	0.96	1111	1.01	1146	1.06	1181	1.11	1216	1.15	1250	1.19

Air Volume (cfm)	External Static (in.w.g.)																			
	1.1		1.2		1.3		1.4		1.5		1.6		1.7		1.8		1.9		2.0	
	RPM	BHP	RPM	BHP	RPM	BHP	RPM	BHP	RPM	BHP	RPM	BHP	RPM	BHP	RPM	BHP	RPM	BHP	RPM	BHP
1100	1089	0.43	1134	0.46	---	---	---	---	---	---	---	---	---	---	---	---	---	---	---	---
1200	1095	0.46	1139	0.50	1186	0.53	1230	0.57	1266	0.60	---	---	---	---	---	---	---	---	---	---
1300	1104	0.50	1146	0.54	1192	0.57	1234	0.60	1269	0.64	1301	0.68	1334	0.71	1367	0.75	---	---	---	---
1400	1114	0.55	1155	0.58	1199	0.61	1240	0.65	1275	0.68	1305	0.72	1338	0.76	1372	0.80	1406	0.83	1440	0.87
1500	1125	0.60	1165	0.63	1208	0.66	1248	0.69	1281	0.73	1311	0.77	1344	0.81	1378	0.85	1412	0.89	1446	0.92
1600	1138	0.65	1177	0.68	1218	0.71	1257	0.75	1290	0.79	1319	0.83	1352	0.87	1385	0.91	1418	0.95	1452	0.98
1700	1152	0.70	1190	0.74	1231	0.77	1268	0.80	1299	0.84	1328	0.89	1360	0.93	1393	0.97	1426	1.01	1459	1.05
1800	1167	0.76	1205	0.80	1244	0.83	1280	0.87	1310	0.91	1338	0.95	1370	0.99	1402	1.04	1434	1.08	1466	1.11
1900	1183	0.82	1221	0.86	1260	0.90	1294	0.94	1323	0.98	1349	1.02	1380	1.07	1412	1.11	1443	1.15	1475	1.19
2000	1201	0.89	1239	0.93	1276	0.97	1310	1.01	1336	1.06	1362	1.10	1392	1.15	1423	1.19	1454	1.23	1485	1.27
2100	1221	0.97	1258	1.01	1294	1.05	1325	1.09	1351	1.14	1376	1.19	1406	1.23	1436	1.27	1466	1.31	1497	1.35
2200	1242	1.05	1277	1.09	1311	1.14	1341	1.18	1365	1.23	1390	1.28	1420	1.32	1450	1.36	1480	1.41	1510	1.45
2300	1262	1.14	1295	1.19	1327	1.24	1355	1.29	1380	1.33	1406	1.37	1435	1.42	1465	1.46	1494	1.50	1524	1.54
2400	1282	1.24	1313	1.30	1343	1.36	1371	1.40	1396	1.44	1423	1.48	1452	1.52	1481	1.56	1510	1.60	1540	1.64

BLOWER DATA - LCH BELT DRIVE - 5 TON - HIGH EFFICIENCY

BLOWER TABLE INCLUDES RESISTANCE FOR BASE UNIT ONLY WITH DRY INDOOR COIL AND AIR FILTERS IN PLACE.

FOR ALL UNITS ADD:

1 - Any factory installed options air resistance (heat section, economizer, etc.).

2 - Any field installed accessories air resistance (duct resistance, diffuser, etc.).

See Page 45 for blower motors and drives and wet coil and options/accessory air resistance data.

HORIZONTAL

Air Volume (cfm)	External Static (in.w.g.)																			
	0.10		0.20		0.30		0.40		0.50		0.60		0.70		0.80		0.9		1.0	
	RPM	BHP	RPM	BHP	RPM	BHP	RPM	BHP	RPM	BHP	RPM	BHP	RPM	BHP	RPM	BHP	RPM	BHP	RPM	BHP
1100	509	0.15	562	0.18	624	0.20	691	0.22	771	0.24	852	0.25	919	0.28	970	0.31	1010	0.35	1049	0.38
1200	535	0.18	589	0.21	650	0.23	715	0.25	792	0.27	869	0.29	932	0.32	980	0.35	1019	0.38	1058	0.42
1300	564	0.21	618	0.24	678	0.27	741	0.29	815	0.31	887	0.33	946	0.36	991	0.39	1030	0.43	1068	0.47
1400	604	0.24	657	0.27	715	0.30	775	0.33	842	0.35	908	0.37	962	0.40	1004	0.43	1042	0.47	1080	0.51
1500	656	0.26	706	0.30	760	0.33	814	0.36	874	0.39	931	0.41	979	0.45	1019	0.48	1056	0.53	1094	0.57
1600	712	0.29	758	0.32	807	0.36	855	0.39	906	0.43	955	0.46	997	0.50	1035	0.54	1071	0.58	1109	0.62
1700	766	0.32	808	0.36	850	0.40	892	0.44	936	0.47	978	0.51	1016	0.56	1052	0.60	1088	0.64	1126	0.68
1800	814	0.36	851	0.40	888	0.44	925	0.49	963	0.53	1000	0.57	1035	0.62	1071	0.66	1107	0.70	1143	0.74
1900	853	0.41	886	0.46	919	0.50	952	0.55	986	0.60	1021	0.64	1056	0.69	1091	0.73	1126	0.77	1163	0.81
2000	883	0.48	913	0.53	944	0.57	976	0.62	1009	0.67	1043	0.71	1078	0.76	1112	0.80	1148	0.84	1183	0.88
2100	906	0.56	936	0.60	967	0.65	999	0.70	1033	0.75	1067	0.79	1101	0.84	1135	0.88	1170	0.92	1206	0.96
2200	930	0.64	960	0.68	991	0.73	1024	0.78	1058	0.83	1092	0.88	1126	0.92	1160	0.96	1195	1.00	1230	1.04
2300	954	0.72	985	0.77	1017	0.82	1051	0.87	1085	0.92	1119	0.96	1152	1.00	1186	1.04	1220	1.08	1254	1.13
2400	981	0.81	1013	0.86	1046	0.91	1079	0.96	1113	1.00	1146	1.05	1180	1.09	1213	1.13	1245	1.18	1278	1.22

Air Volume (cfm)	External Static (in.w.g.)																			
	1.1		1.2		1.3		1.4		1.5		1.6		1.7		1.8		1.9		2.0	
	RPM	BHP	RPM	BHP	RPM	BHP	RPM	BHP	RPM	BHP	RPM	BHP	RPM	BHP	RPM	BHP	RPM	BHP	RPM	BHP
1100	1091	0.42	1134	0.45	1176	0.48	1218	0.51	1258	0.54	1297	0.57	1335	0.59	---	---	---	---	---	---
1200	1099	0.46	1141	0.49	1182	0.52	1223	0.55	1263	0.58	1302	0.61	1339	0.64	1376	0.67	1410	0.70	1444	0.72
1300	1108	0.50	1149	0.53	1190	0.56	1230	0.59	1270	0.63	1308	0.66	1345	0.70	1381	0.73	1415	0.75	1449	0.78
1400	1120	0.55	1160	0.58	1200	0.61	1240	0.65	1278	0.68	1315	0.72	1352	0.75	1387	0.78	1421	0.81	1454	0.84
1500	1133	0.60	1172	0.63	1212	0.67	1250	0.70	1288	0.74	1324	0.77	1360	0.81	1394	0.84	1428	0.87	1460	0.90
1600	1147	0.66	1186	0.69	1225	0.72	1263	0.76	1299	0.80	1334	0.83	1369	0.87	1402	0.90	1435	0.94	1467	0.96
1700	1164	0.72	1202	0.75	1240	0.78	1276	0.82	1311	0.86	1345	0.90	1379	0.93	1411	0.97	1443	1.00	1475	1.03
1800	1181	0.78	1219	0.81	1256	0.85	1291	0.89	1324	0.93	1357	0.97	1390	1.00	1421	1.04	1453	1.07	1483	1.10
1900	1200	0.85	1237	0.88	1273	0.92	1306	0.96	1339	1.00	1371	1.04	1402	1.08	1433	1.11	1463	1.15	1493	1.18
2000	1220	0.92	1257	0.96	1291	1.00	1323	1.04	1354	1.08	1385	1.12	1416	1.16	1446	1.20	1476	1.23	1505	1.26
2100	1242	1.00	1277	1.04	1310	1.08	1340	1.13	1371	1.17	1401	1.21	1431	1.25	1460	1.29	1489	1.32	1519	1.36
2200	1265	1.08	1299	1.13	1330	1.18	1359	1.23	1388	1.27	1418	1.31	1447	1.35	1476	1.39	1504	1.42	1533	1.45
2300	1288	1.17	1320	1.23	1350	1.28	1378	1.34	1406	1.38	1435	1.42	1464	1.46	1492	1.50	1521	1.53	1549	1.56
2400	1311	1.28	1341	1.33	1370	1.40	1397	1.45	1425	1.50	1454	1.54	1482	1.57	1510	1.61	1538	1.64	1567	1.67

BLOWER DATA - LGH BELT DRIVE - 6 TON - HIGH EFFICIENCY

BLOWER TABLE INCLUDES RESISTANCE FOR BASE UNIT ONLY WITH DRY INDOOR COIL AND AIR FILTERS IN PLACE.

FOR ALL UNITS ADD:

1 - Any factory installed options air resistance (heat section, economizer, etc.).

2 - Any field installed accessories air resistance (duct resistance, diffuser, etc.).

See page 45 for blower motors and drives and wet coil and options/accessory air resistance data.

DOWNFLOW

Air Volume (cfm)	External Static (in.w.g.)																			
	0.10		0.20		0.30		0.40		0.50		0.60		0.70		0.80		0.9		1.0	
	RPM	BHP	RPM	BHP	RPM	BHP	RPM	BHP	RPM	BHP	RPM	BHP	RPM	BHP	RPM	BHP	RPM	BHP	RPM	BHP
1900	510	0.45	544	0.5	579	0.55	614	0.6	649	0.65	684	0.7	718	0.74	752	0.79	784	0.83	812	0.88
2000	526	0.49	560	0.55	595	0.6	629	0.65	663	0.7	697	0.75	730	0.79	763	0.84	794	0.88	820	0.93
2100	542	0.54	576	0.59	610	0.65	644	0.7	678	0.75	711	0.8	743	0.84	775	0.89	804	0.94	830	0.98
2200	560	0.59	593	0.64	627	0.7	660	0.75	693	0.8	725	0.85	757	0.9	787	0.94	814	0.99	840	1.03
2300	578	0.64	610	0.7	644	0.75	676	0.81	709	0.86	740	0.91	770	0.95	799	1	826	1.05	851	1.09
2400	597	0.7	629	0.75	661	0.81	693	0.86	725	0.91	755	0.96	784	1.01	812	1.06	838	1.11	862	1.15
2500	617	0.76	648	0.81	679	0.87	710	0.92	741	0.97	770	1.03	799	1.08	825	1.13	850	1.17	875	1.22
2600	637	0.82	667	0.87	698	0.93	728	0.98	758	1.04	786	1.09	814	1.15	839	1.2	864	1.24	887	1.28
2700	658	0.88	687	0.94	717	1	746	1.05	775	1.11	802	1.16	829	1.22	853	1.27	877	1.31	901	1.36
2800	679	0.95	708	1.01	736	1.07	764	1.12	792	1.18	819	1.24	844	1.3	868	1.35	892	1.39	915	1.43
2900	701	1.02	728	1.08	756	1.14	783	1.2	809	1.26	835	1.32	860	1.38	884	1.43	907	1.47	930	1.52
Air Volume (cfm)	External Static (in.w.g.)																			
	1.1		1.2		1.3		1.4		1.5		1.6		1.7		1.8		1.9		2.0	
	RPM	BHP	RPM	BHP	RPM	BHP	RPM	BHP	RPM	BHP	RPM	BHP	RPM	BHP	RPM	BHP	RPM	BHP	RPM	BHP
1900	837	0.92	861	0.96	886	1	913	1.04	939	1.07	966	1.11	992	1.16	1017	1.21	1041	1.27	1065	1.33
2000	845	0.97	870	1.01	895	1.05	921	1.09	948	1.12	974	1.17	999	1.22	1023	1.27	1047	1.33	1070	1.39
2100	855	1.02	879	1.06	904	1.1	930	1.14	956	1.18	982	1.22	1006	1.28	1030	1.34	1053	1.4	1075	1.46
2200	865	1.08	889	1.12	914	1.15	940	1.19	966	1.24	990	1.29	1014	1.34	1037	1.41	1059	1.47	1081	1.54
2300	875	1.13	900	1.17	925	1.21	951	1.25	976	1.3	999	1.35	1022	1.41	1044	1.48	1066	1.55	1087	1.62
2400	887	1.19	912	1.23	936	1.27	961	1.32	986	1.37	1009	1.43	1031	1.49	1052	1.57	1073	1.64	1094	1.71
2500	899	1.25	923	1.29	948	1.34	973	1.39	996	1.44	1018	1.51	1039	1.58	1060	1.65	1080	1.73	1101	1.8
2600	912	1.32	936	1.36	960	1.41	984	1.46	1007	1.52	1028	1.59	1049	1.67	1069	1.75	1089	1.82	1109	1.89
2700	925	1.4	949	1.44	973	1.49	996	1.55	1018	1.61	1038	1.69	1058	1.76	1078	1.84	1098	1.92	1118	1.99
2800	939	1.47	962	1.52	985	1.57	1008	1.64	1029	1.71	1049	1.79	1069	1.87	1088	1.94	1107	2.02	1127	2.09
2900	953	1.56	976	1.61	998	1.67	1020	1.73	1041	1.81	1060	1.89	1079	1.98	1098	2.06	1117	2.13	1137	2.21

BLOWER DATA - LGH BELT DRIVE - 6 TON - HIGH EFFICIENCY

BLOWER TABLE INCLUDES RESISTANCE FOR BASE UNIT ONLY WITH DRY INDOOR COIL AND AIR FILTERS IN PLACE.

FOR ALL UNITS ADD:

1 - Any factory installed options air resistance (heat section, economizer, etc.).

2 - Any field installed accessories air resistance (duct resistance, diffuser, etc.).

See page 45 for blower motors and drives and wet coil and options/accessory air resistance data.

HORIZONTAL

Air Volume (cfm)	External Static (in.w.g.)																			
	0.10		0.20		0.30		0.40		0.50		0.60		0.70		0.80		0.9		1.0	
	RPM	BHP	RPM	BHP	RPM	BHP	RPM	BHP	RPM	BHP	RPM	BHP	RPM	BHP	RPM	BHP	RPM	BHP	RPM	BHP
1900	485	0.55	516	0.57	549	0.59	583	0.62	618	0.65	654	0.69	689	0.73	724	0.77	758	0.82	790	0.86
2000	499	0.59	531	0.61	563	0.63	597	0.66	631	0.7	666	0.73	701	0.77	734	0.82	767	0.86	798	0.91
2100	514	0.63	546	0.65	578	0.68	611	0.71	645	0.74	679	0.78	712	0.82	745	0.86	777	0.91	806	0.96
2200	530	0.68	562	0.7	594	0.73	627	0.76	660	0.79	693	0.83	725	0.87	757	0.92	787	0.96	816	1.01
2300	548	0.73	579	0.75	610	0.78	643	0.81	675	0.85	707	0.88	738	0.93	769	0.97	798	1.02	826	1.06
2400	566	0.78	596	0.81	628	0.84	659	0.87	691	0.9	722	0.94	752	0.98	782	1.03	810	1.08	837	1.12
2500	585	0.84	615	0.86	645	0.9	676	0.93	707	0.96	737	1	767	1.05	795	1.09	822	1.14	848	1.19
2600	604	0.9	634	0.93	664	0.96	694	0.99	724	1.03	753	1.07	781	1.11	809	1.15	835	1.2	861	1.25
2700	624	0.96	653	0.99	682	1.02	712	1.06	741	1.09	769	1.13	796	1.18	823	1.22	849	1.27	873	1.32
2800	645	1.02	673	1.05	701	1.09	730	1.12	758	1.16	785	1.2	812	1.25	838	1.29	862	1.34	886	1.39
2900	665	1.09	693	1.12	721	1.16	748	1.19	775	1.23	802	1.27	827	1.32	852	1.36	877	1.41	900	1.46

Air Volume (cfm)	External Static (in.w.g.)																			
	1.1		1.2		1.3		1.4		1.5		1.6		1.7		1.8		1.9		2.0	
	RPM	BHP	RPM	BHP	RPM	BHP	RPM	BHP	RPM	BHP	RPM	BHP	RPM	BHP	RPM	BHP	RPM	BHP	RPM	BHP
1900	819	0.9	846	0.94	871	0.98	897	1.02	922	1.05	948	1.09	974	1.13	999	1.18	1025	1.23	1050	1.28
2000	826	0.95	852	0.99	877	1.03	902	1.06	928	1.1	953	1.14	979	1.18	1004	1.23	1029	1.28	1054	1.34
2100	834	1	859	1.04	884	1.08	909	1.12	934	1.15	960	1.2	985	1.24	1010	1.29	1034	1.35	1058	1.4
2200	842	1.05	868	1.1	892	1.13	917	1.17	942	1.21	967	1.26	992	1.3	1016	1.36	1040	1.41	1063	1.47
2300	852	1.11	877	1.15	901	1.19	926	1.23	950	1.27	975	1.32	999	1.37	1023	1.42	1046	1.48	1069	1.54
2400	862	1.17	887	1.21	911	1.25	935	1.3	959	1.34	983	1.39	1007	1.44	1030	1.5	1053	1.56	1075	1.62
2500	873	1.23	897	1.28	921	1.32	945	1.36	969	1.41	992	1.46	1016	1.52	1038	1.58	1060	1.64	1082	1.7
2600	885	1.3	909	1.34	932	1.39	955	1.43	979	1.49	1002	1.54	1025	1.6	1047	1.66	1069	1.73	1090	1.79
2700	897	1.37	920	1.41	944	1.46	967	1.51	990	1.57	1012	1.62	1034	1.69	1056	1.75	1077	1.82	1098	1.89
2800	910	1.44	933	1.49	955	1.54	978	1.6	1001	1.65	1023	1.72	1044	1.78	1066	1.85	1086	1.92	1107	1.99
2900	923	1.52	945	1.57	968	1.63	990	1.68	1012	1.75	1034	1.81	1055	1.88	1076	1.95	1096	2.02	1116	2.09

BLOWER DATA - LCH BELT DRIVE - 6 TON - HIGH EFFICIENCY

BLOWER TABLE INCLUDES RESISTANCE FOR BASE UNIT ONLY WITH DRY INDOOR COIL AND AIR FILTERS IN PLACE.

FOR ALL UNITS ADD:

1 - Any factory installed options air resistance (heat section, economizer, etc.).

2 - Any field installed accessories air resistance (duct resistance, diffuser, etc.).

See Page 45 for blower motors and drives and wet coil and options/accessory air resistance data.

DOWNFLOW

Air Volume (cfm)	External Static (in.w.g.)																			
	0.10		0.20		0.30		0.40		0.50		0.60		0.70		0.80		0.9		1.0	
	RPM	BHP	RPM	BHP	RPM	BHP	RPM	BHP	RPM	BHP	RPM	BHP	RPM	BHP	RPM	BHP	RPM	BHP	RPM	BHP
1900	480	0.38	512	0.44	545	0.51	579	0.57	614	0.63	648	0.7	683	0.76	719	0.83	752	0.89	781	0.95
2000	493	0.43	525	0.49	558	0.56	592	0.62	626	0.68	659	0.75	693	0.81	728	0.88	759	0.94	788	1
2100	507	0.48	539	0.54	572	0.61	605	0.67	639	0.74	671	0.8	704	0.86	737	0.93	768	0.99	795	1.04
2200	522	0.53	554	0.6	587	0.66	619	0.73	652	0.79	684	0.86	716	0.92	747	0.98	777	1.04	803	1.1
2300	537	0.59	569	0.65	602	0.72	634	0.79	666	0.85	697	0.91	728	0.98	758	1.04	786	1.1	812	1.15
2400	553	0.65	585	0.71	617	0.78	649	0.85	680	0.91	711	0.98	740	1.04	769	1.1	796	1.15	821	1.21
2500	570	0.71	602	0.78	633	0.84	665	0.91	695	0.97	725	1.04	753	1.1	781	1.16	807	1.22	832	1.27
2600	588	0.77	619	0.84	650	0.91	680	0.97	710	1.04	739	1.1	767	1.16	793	1.22	818	1.28	842	1.33
2700	607	0.84	637	0.91	667	0.97	697	1.04	726	1.11	753	1.17	780	1.23	806	1.29	830	1.35	854	1.4
2800	626	0.91	655	0.97	684	1.04	713	1.11	741	1.18	768	1.24	794	1.3	819	1.36	842	1.42	866	1.47
2900	646	0.98	674	1.05	702	1.11	730	1.18	757	1.25	783	1.32	808	1.38	832	1.44	855	1.49	878	1.54

Air Volume (cfm)	External Static (in.w.g.)																			
	1.1		1.2		1.3		1.4		1.5		1.6		1.7		1.8		1.9		2.0	
	RPM	BHP	RPM	BHP	RPM	BHP	RPM	BHP	RPM	BHP	RPM	BHP	RPM	BHP	RPM	BHP	RPM	BHP	RPM	BHP
1900	807	1	832	1.04	857	1.07	883	1.11	912	1.14	941	1.17	968	1.21	993	1.25	1017	1.29	1039	1.34
2000	813	1.04	838	1.08	862	1.12	889	1.15	917	1.19	945	1.22	972	1.26	997	1.3	1020	1.35	1042	1.4
2100	820	1.09	844	1.13	869	1.17	895	1.21	923	1.24	951	1.28	977	1.32	1001	1.36	1024	1.41	1046	1.46
2200	828	1.14	852	1.18	877	1.22	903	1.26	930	1.3	957	1.33	983	1.37	1006	1.42	1028	1.47	1050	1.53
2300	836	1.2	861	1.24	885	1.28	911	1.31	938	1.35	964	1.39	989	1.43	1012	1.48	1033	1.54	1054	1.6
2400	846	1.25	870	1.29	895	1.33	920	1.37	947	1.41	972	1.45	996	1.5	1018	1.55	1039	1.61	1059	1.67
2500	856	1.31	880	1.35	905	1.39	930	1.43	956	1.47	980	1.52	1003	1.57	1024	1.63	1044	1.69	1064	1.76
2600	866	1.38	891	1.42	915	1.46	940	1.5	965	1.54	988	1.59	1010	1.65	1031	1.71	1050	1.78	1069	1.84
2700	878	1.44	902	1.48	926	1.52	950	1.57	974	1.61	997	1.67	1018	1.73	1037	1.8	1056	1.87	1075	1.93
2800	889	1.51	913	1.55	937	1.59	961	1.64	984	1.69	1006	1.75	1026	1.82	1044	1.89	1063	1.96	1081	2.03
2900	902	1.58	925	1.63	949	1.67	972	1.72	994	1.78	1015	1.84	1034	1.91	1052	1.99	1069	2.06	1087	2.13

BLOWER DATA - LCH BELT DRIVE - 6 TON - HIGH EFFICIENCY

BLOWER TABLE INCLUDES RESISTANCE FOR BASE UNIT ONLY WITH DRY INDOOR COIL AND AIR FILTERS IN PLACE.

FOR ALL UNITS ADD:

1 - Any factory installed options air resistance (heat section, economizer, etc.).

2 - Any field installed accessories air resistance (duct resistance, diffuser, etc.).

See Page 45 for blower motors and drives and wet coil and options/accessory air resistance data.

HORIZONTAL

Air Volume (cfm)	External Static (in.w.g.)																			
	0.10		0.20		0.30		0.40		0.50		0.60		0.70		0.80		0.9		1.0	
	RPM	BHP	RPM	BHP	RPM	BHP	RPM	BHP	RPM	BHP	RPM	BHP	RPM	BHP	RPM	BHP	RPM	BHP	RPM	BHP
1900	507	0.55	538	0.58	571	0.6	604	0.63	639	0.66	673	0.7	707	0.74	740	0.78	772	0.82	802	0.86
2000	522	0.59	554	0.62	586	0.64	620	0.67	653	0.71	687	0.74	720	0.78	752	0.82	783	0.87	812	0.91
2100	539	0.63	571	0.66	603	0.69	636	0.72	669	0.75	702	0.79	734	0.83	765	0.88	795	0.92	823	0.97
2200	557	0.68	588	0.71	620	0.74	652	0.77	685	0.81	717	0.84	748	0.89	778	0.93	807	0.98	834	1.03
2300	576	0.73	607	0.76	638	0.79	670	0.83	701	0.86	733	0.9	763	0.95	792	0.99	820	1.04	846	1.09
2400	596	0.79	626	0.82	657	0.85	688	0.89	718	0.92	749	0.96	778	1.01	806	1.06	833	1.11	858	1.16
2500	616	0.85	645	0.88	676	0.91	706	0.95	736	0.99	765	1.03	794	1.08	821	1.13	847	1.18	871	1.23
2600	636	0.91	665	0.94	695	0.98	724	1.02	754	1.06	782	1.1	809	1.15	836	1.2	861	1.25	885	1.3
2700	657	0.97	685	1.01	714	1.04	743	1.08	771	1.13	799	1.17	826	1.22	851	1.27	875	1.32	899	1.37
2800	677	1.03	706	1.07	734	1.11	762	1.16	790	1.2	816	1.25	842	1.3	867	1.35	890	1.4	913	1.45
2900	698	1.1	726	1.14	754	1.19	781	1.23	808	1.28	834	1.33	859	1.38	883	1.43	906	1.48	928	1.54

Air Volume (cfm)	External Static (in.w.g.)																			
	1.1		1.2		1.3		1.4		1.5		1.6		1.7		1.8		1.9		2.0	
	RPM	BHP	RPM	BHP	RPM	BHP	RPM	BHP	RPM	BHP	RPM	BHP	RPM	BHP	RPM	BHP	RPM	BHP	RPM	BHP
1900	830	0.91	857	0.95	883	0.99	910	1.04	937	1.09	964	1.13	991	1.18	1017	1.23	1042	1.28	1067	1.34
2000	839	0.96	865	1	891	1.05	917	1.09	944	1.14	970	1.19	996	1.24	1022	1.29	1047	1.34	1071	1.4
2100	849	1.02	874	1.06	900	1.11	926	1.15	952	1.2	978	1.25	1003	1.3	1028	1.35	1052	1.41	1075	1.46
2200	860	1.08	885	1.12	910	1.17	935	1.21	960	1.26	986	1.31	1010	1.36	1034	1.42	1058	1.48	1081	1.53
2300	871	1.14	895	1.19	920	1.23	945	1.28	969	1.33	994	1.38	1018	1.43	1042	1.49	1065	1.55	1087	1.61
2400	883	1.21	907	1.25	931	1.3	955	1.35	979	1.4	1003	1.45	1027	1.51	1050	1.57	1072	1.63	1094	1.69
2500	895	1.28	919	1.32	942	1.37	966	1.42	990	1.48	1013	1.53	1036	1.59	1059	1.65	1081	1.71	1102	1.78
2600	908	1.35	931	1.4	955	1.45	978	1.5	1001	1.56	1024	1.62	1046	1.68	1068	1.74	1089	1.8	1110	1.87
2700	922	1.43	945	1.48	967	1.53	990	1.59	1013	1.65	1035	1.71	1056	1.77	1078	1.84	1099	1.9	1119	1.96
2800	936	1.51	958	1.56	980	1.62	1003	1.68	1025	1.74	1046	1.8	1067	1.87	1088	1.93	1109	2	1129	2.06
2900	950	1.6	972	1.66	994	1.72	1016	1.78	1037	1.84	1058	1.91	1079	1.97	1099	2.04	1119	2.11	1139	2.17

BLOWER DATA - DIRECT DRIVE - 3 TON - ULTRA HIGH EFFICIENCY

036 DIRECT DRIVE BLOWER - BASE UNIT

BLOWER TABLE INCLUDES RESISTANCE FOR BASE UNIT ONLY WITH DRY INDOOR COIL AND AIR FILTERS IN PLACE.

FOR ALL UNITS ADD:

1 - Any factory installed options air resistance (heat section, economizer, etc.).

2 - Any field installed accessories air resistance (duct resistance, diffuser, etc.).

See page 45 for blower motors and drives and wet coil and options/accessory air resistance data.

DOWNFLOW

External Static Press. in. w.g.	Percentage of Total Motor Torque																													
	10%			20%			30%			40%			50%			60%			70%			80%			90%			100%		
	Cfm	RPM	Watts	Cfm	RPM	Watts	Cfm	RPM	Watts	Cfm	RPM	Watts	Cfm	RPM	Watts	Cfm	RPM	Watts	Cfm	RPM	Watts	Cfm	RPM	Watts	Cfm	RPM	Watts	Cfm	RPM	Watts
0.1	459	29	380	698	47	414	903	76	475	1069	110	539	1224	153	598	1374	195	632	1500	248	677	1617	312	723	1729	375	763	1821	447	803
0.2	357	32	464	596	55	520	828	86	563	1023	120	597	1180	165	634	1331	210	685	1461	264	727	1590	325	757	1704	387	796	1796	460	835
0.3	255	36	554	521	61	596	772	94	607	977	130	654	1137	177	706	1302	220	720	1435	274	776	1550	344	808	1666	406	843	1772	473	866
0.4	166	39	637	445	67	669	716	102	694	916	143	728	1108	185	740	1258	235	772	1397	289	808	1523	356	841	1641	417	874	1735	492	911
0.5	---	---	---	369	72	739	661	111	759	869	153	782	1050	200	807	1214	249	822	1358	304	855	1483	372	889	1603	434	919	1710	504	940
0.6	---	---	---	---	---	---	---	---	---	823	162	834	1006	212	856	1171	262	872	1319	318	900	1456	383	920	1565	450	962	1674	521	983
0.7	---	---	---	---	---	---	---	---	---	762	175	901	963	223	903	1127	275	920	1280	331	944	1416	398	966	1540	460	991	1637	536	1024
0.8	---	---	---	---	---	---	---	---	---	716	184	950	905	237	964	1083	287	968	1241	344	986	1376	412	1011	1502	474	1032	1612	546	1050
0.9	---	---	---	---	---	---	---	---	---	670	193	997	862	247	1007	1040	299	1014	1202	356	1027	1336	425	1054	1464	488	1072	1576	560	1088
1.0	---	---	---	---	---	---	---	---	---	623	202	1043	818	257	1049	981	314	1074	1151	371	1079	1296	437	1095	1426	501	1110	1539	573	1125
1.1	---	---	---	---	---	---	---	---	---	---	---	---	---	---	938	325	1118	1112	1112	1112	1117	1256	447	1135	1388	513	1147	1490	589	1171
1.2	---	---	---	---	---	---	---	---	---	---	---	---	---	---	---	---	---	---	---	---	---	1215	457	1174	1344	526	1188	1453	600	1204

HORIZONTAL

External Static Press. in. w.g.	Percentage of Total Motor Torque																															
	10%			20%			30%			40%			50%			60%			70%			80%			90%			100%				
	Cfm	RPM	Watts	Cfm	RPM	Watts	Cfm	RPM	Watts	Cfm	RPM	Watts	Cfm	RPM	Watts	Cfm	RPM	Watts	Cfm	RPM	Watts	Cfm	RPM	Watts	Cfm	RPM	Watts	Cfm	RPM	Watts	Cfm	RPM
0.1	432	29	395	674	49	443	882	79	511	1053	115	567	1211	156	617	1334	205	676	1463	260	725	1583	322	769	1692	391	813	1791	466	852		
0.2	334	32	479	581	56	537	822	87	582	1021	122	609	1178	165	659	1308	215	712	1439	270	758	1560	333	801	1670	402	843	1771	477	877		
0.3	217	36	578	517	61	603	763	96	651	953	137	696	1128	179	720	1265	230	768	1400	286	809	1522	350	850	1634	420	888	1737	494	920		
0.4	149	39	636	436	68	684	703	105	719	918	145	738	1079	193	781	1237	239	805	1374	297	842	1498	361	881	1611	431	917	1714	505	947		
0.5	---	---	---	372	73	749	644	114	786	867	155	799	1046	201	820	1194	254	858	1335	312	891	1460	377	927	1576	447	960	1680	521	987		
0.6	---	---	---	---	---	---	---	---	---	816	166	858	997	214	879	1152	267	909	1296	326	938	1435	387	957	1552	457	987	1645	536	1026		
0.7	---	---	---	---	---	---	---	---	---	765	176	915	948	227	936	1109	280	959	1257	339	983	1398	401	1000	1517	471	1026	1611	550	1063		
0.8	---	---	---	---	---	---	---	---	---	714	185	970	915	235	974	1081	288	991	1231	348	1013	1360	415	1041	1482	484	1064	1588	558	1087		
0.9	---	---	---	---	---	---	---	---	---	663	194	1022	866	247	1030	1024	304	1052	1179	364	1070	1322	427	1081	1434	500	1112	1542	575	1133		
1.0	---	---	---	---	---	---	---	---	---	611	203	1073	816	259	1085	981	315	1096	1140	376	1112	1285	438	1118	1399	511	1146	1508	586	1165		
1.1	---	---	---	---	---	---	---	---	---	---	---	---	---	---	939	325	1138	1138	1138	1138	1152	1235	452	1166	1364	521	1178	1474	596	1197		
1.2	---	---	---	---	---	---	---	---	---	---	---	---	---	---	---	---	---	---	---	---	---	1198	461	1200	1323	532	1214	1439	606	1227		

BLOWER DATA - DIRECT DRIVE - 4 TON - ULTRA HIGH EFFICIENCY

048 DIRECT DRIVE BLOWER - BASE UNIT

BLOWER TABLE INCLUDES RESISTANCE FOR BASE UNIT ONLY WITH DRY INDOOR COIL AND AIR FILTERS IN PLACE.

FOR ALL UNITS ADD:

- 1 - Any factory installed options air resistance (heat section, economizer, etc.).
- 2 - Any field installed accessories air resistance (duct resistance, diffuser, etc.).

See page 45 for blower motors and drives and wet coil and options/accessory air resistance data.

DOWNFLOW

External Static Press. in. w.g.	Percentage of Total Motor Torque																													
	10%			20%			30%			40%			50%			60%			70%			80%			90%			100%		
	Cfm	RPM	Watts	Cfm	RPM	Watts	Cfm	RPM	Watts	Cfm	RPM	Watts	Cfm	RPM	Watts	Cfm	RPM	Watts	Cfm	RPM	Watts	Cfm	RPM	Watts	Cfm	RPM	Watts	Cfm	RPM	Watts
0.1	682	46	420	894	79	499	1148	131	579	1366	192	651	1551	268	726	348	781	1885	445	840	2031	550	893	2165	669	950	2290	790	993	
0.2	583	52	510	836	87	562	1105	142	635	1329	204	697	1530	279	756	368	827	1856	466	883	2006	567	925	2149	683	972	2271	813	1023	
0.3	484	59	601	778	96	629	1062	152	688	1292	217	744	1500	294	800	380	856	1837	479	910	1981	585	958	2125	704	1005	2252	834	1051	
0.4	410	64	666	720	105	697	1019	162	739	1255	231	792	1469	309	841	397	898	1808	498	950	1956	603	992	2100	723	1036	2233	851	1076	
0.5	---	---	---	662	114	764	961	176	805	1218	244	840	1428	327	895	414	937	1780	515	987	1931	622	1025	2076	741	1066	2205	874	1111	
0.6	---	---	---	---	---	---	---	---	---	1182	257	887	1398	341	934	429	974	1751	532	1022	1906	641	1058	2052	758	1095	2186	886	1131	
0.7	---	---	---	---	---	---	---	---	---	1145	270	933	1367	354	972	443	1009	1722	548	1056	1874	663	1098	2028	774	1122	2148	903	1167	
0.8	---	---	---	---	---	---	---	---	---	1096	287	992	1326	372	1021	462	1056	1693	564	1090	1850	679	1129	1996	792	1157	2111	913	1196	
0.9	---	---	---	---	---	---	---	---	---	1047	302	1047	1296	385	1058	476	1090	1664	579	1123	1824	693	1157	1963	807	1188	2073	916	1219	
1.0	---	---	---	---	---	---	---	---	---	1010	312	1085	1255	403	1107	491	1125	1635	594	1155	1787	710	1195	1931	818	1216	2036	912	1236	
1.1	---	---	---	---	---	---	---	---	---	---	---	---	---	---	1425	505	1160	1606	609	1188	1762	717	1216	1883	828	1250	1960	890	1260	
1.2	---	---	---	---	---	---	---	---	---	---	---	---	---	---	---	---	---	---	---	---	1687	715	1254	1834	827	1275	1848	834	1274	

HORIZONTAL

External Static Press. in. w.g.	Percentage of Total Motor Torque																													
	10%			20%			30%			40%			50%			60%			70%			80%			90%			100%		
	Cfm	RPM	Watts	Cfm	RPM	Watts	Cfm	RPM	Watts	Cfm	RPM	Watts	Cfm	RPM	Watts	Cfm	RPM	Watts	Cfm	RPM	Watts	Cfm	RPM	Watts	Cfm	RPM	Watts	Cfm	RPM	Watts
0.1	641	46	443	875	82	522	1127	137	614	1334	202	691	1524	280	762	367	827	1866	470	881	1997	581	955	2119	699	1010	2241	830	1058	
0.2	568	50	505	831	90	582	1097	144	650	1310	211	723	1504	290	793	379	859	1829	484	921	1977	600	986	2106	715	1032	2227	846	1080	
0.3	483	56	584	778	98	647	1050	155	706	1269	225	777	1470	308	844	396	900	1799	498	957	1953	621	1022	2079	743	1072	2199	873	1118	
0.4	398	62	661	724	106	707	1004	167	764	1228	240	831	1436	325	891	413	941	1777	511	985	1930	640	1055	2062	758	1096	2181	888	1140	
0.5	---	---	---	671	113	763	957	179	822	1201	250	867	1413	335	921	427	973	1748	530	1025	1906	657	1087	2036	777	1129	2153	904	1170	
0.6	---	---	---	---	---	---	---	---	---	1161	265	919	1378	350	964	447	1019	1718	549	1064	1874	676	1124	2000	796	1166	2115	917	1202	
0.7	---	---	---	---	---	---	---	---	---	1120	279	970	1344	365	1006	459	1049	1696	564	1093	1850	688	1150	1974	805	1189	2078	922	1228	
0.8	---	---	---	---	---	---	---	---	---	1093	288	1003	1310	379	1047	477	1091	1667	583	1131	1818	700	1180	1930	812	1220	2040	919	1246	
0.9	---	---	---	---	---	---	---	---	---	1052	302	1051	1275	393	1087	488	1118	1644	595	1158	1779	711	1213	1896	812	1239	1984	903	1265	
1.0	---	---	---	---	---	---	---	---	---	1012	314	1096	1241	407	1128	502	1155	1615	610	1191	1747	715	1235	1843	802	1259	1910	865	1276	
1.1	---	---	---	---	---	---	---	---	---	---	---	---	---	---	1386	516	1201	1571	625	1232	1684	713	1266	1738	760	1277	1760	775	1282	
1.2	---	---	---	---	---	---	---	---	---	---	---	---	---	---	---	---	---	---	---	---	1620	697	1282	1633	707	1283	1667	736	1296	

BLOWER DATA - DIRECT DRIVE - 5 AND 6 TON - ULTRA HIGH EFFICIENCY

060/074 DIRECT DRIVE BLOWER - BASE UNIT

BLOWER TABLE INCLUDES RESISTANCE FOR BASE UNIT ONLY WITH DRY INDOOR COIL AND AIR FILTERS IN PLACE.

FOR ALL UNITS ADD:

- 1 - Any factory installed options air resistance (heat section, economizer, etc.).
- 2 - Any field installed accessories air resistance (duct resistance, diffuser, etc.).

See page 45 for blower motors and drives and wet coil and options/accessory air resistance data.

DOWNFLOW

External Static Press. in. w.g.	Percentage of Total Motor Torque																																				
	10%			20%			30%			40%			50%			60%			70%			80%			90%			100%									
	Cfm	RPM	Watts	Cfm	RPM	Watts	Cfm	RPM	Watts	Cfm	RPM	Watts	Cfm	RPM	Watts	Cfm	RPM	Watts	Cfm	RPM	Watts	Cfm	RPM	Watts	Cfm	RPM	Watts	Cfm	RPM	Watts	Cfm	RPM	Watts				
0.1	743	58	428	992	100	492	1284	161	556	1526	231	607	737	1890	427	686	2220	800	848	2362	842	901	2478	996	938												
0.2	661	65	497	928	110	556	1231	175	610	1479	251	662	761	1872	440	705	2198	827	876	2344	860	925	2468	1016	969												
0.3	579	71	563	881	118	602	1179	188	663	1431	270	716	807	1835	466	724	2024	863	903	2322	881	952	2448	1035	993												
0.4	518	76	611	818	128	662	1126	202	716	1400	283	751	837	1811	483	743	1995	898	930	2301	900	978	2428	1053	1016												
0.5	---	---	---	754	138	719	1074	216	768	1352	301	801	881	1775	507	769	2120	925	968	2280	919	1002	2403	1074	1043												
0.6	---	---	---	---	---	---	---	---	---	1305	319	850	922	1738	529	785	2098	963	992	2248	945	1037	2383	1090	1064												
0.7	---	---	---	---	---	---	---	---	---	1273	330	882	948	1714	544	808	2064	1000	1026	2227	961	1059	2353	1113	1094												
0.8	---	---	---	---	---	---	---	---	---	1226	347	928	986	1678	564	830	2031	1033	1058	2195	983	1090	2323	1133	1121												
0.9	---	---	---	---	---	---	---	---	---	1178	363	972	1022	1641	583	849	1998	1065	1088	2163	1004	1119	2293	1151	1147												
1.0	---	---	---	---	---	---	---	---	---	1147	374	1000	1057	1605	601	873	1953	1094	1125	2131	1022	1146	2263	1167	1170												
1.1	---	---	---	---	---	---	---	---	---	---	---	---	---	1556	623	1099	1755	1129	1151	2089	1043	1177	2203	1193	1211												
1.2	---	---	---	---	---	---	---	---	---	---	---	---	---	---	---	---	---	---	---	1875	906	1181	2036	1211	1227												

HORIZONTAL

External Static Press. in. w.g.	Percentage of Total Motor Torque																																					
	10%			20%			30%			40%			50%			60%			70%			80%			90%			100%										
	Cfm	RPM	Watts	Cfm	RPM	Watts	Cfm	RPM	Watts	Cfm	RPM	Watts	Cfm	RPM	Watts	Cfm	RPM	Watts	Cfm	RPM	Watts	Cfm	RPM	Watts	Cfm	RPM	Watts	Cfm	RPM	Watts	Cfm	RPM	Watts					
0.1	695	49	431	1051	88	470	1280	157	562	1430	314	665	807	1798	526	687	2100	793	848	2228	947	979	2351	1107	1022													
0.2	610	55	495	973	96	543	1233	166	607	1382	332	715	847	1762	547	705	2079	808	847	2207	965	1002	2332	1126	1043													
0.3	525	61	560	914	104	612	1186	177	657	1347	345	752	873	1738	561	737	1907	890	927	2047	982	1024	2308	1148	1069													
0.4	461	66	611	856	115	695	1138	190	714	1312	358	788	893	1702	581	811	1877	958	958	2026	1046	1046	2289	1164	1088													
0.5	---	---	---	822	122	749	1095	202	772	1277	370	823	936	1678	593	864	1995	987	1030	2144	1013	1067	2264	1182	1111													
0.6	---	---	---	---	---	---	---	---	---	1242	382	857	972	1642	612	877	1974	1007	1050	2112	1035	1096	2239	1197	1133													
0.7	---	---	---	---	---	---	---	---	---	1194	398	901	1029	1618	624	896	1943	1044	1079	2091	1048	1115	2208	1213	1158													
0.8	---	---	---	---	---	---	---	---	---	1148	413	943	1061	1582	641	914	1912	1071	1107	2059	1065	1142	2184	1223	1176													
0.9	---	---	---	---	---	---	---	---	---	1112	424	974	1092	1546	657	928	1880	1096	1135	2028	1081	1167	2147	1233	1200													
1.0	---	---	---	---	---	---	---	---	---	1069	438	1011	1092	1510	673	948	1849	1129	1162	1996	1095	1191	2110	1238	1221													
1.1	---	---	---	---	---	---	---	---	---	---	---	---	---	1474	688	1122	1652	1156	1188	1984	1107	1212	2060	1235	1243													
1.2	---	---	---	---	---	---	---	---	---	---	---	---	---	---	---	---	---	---	---	1781	982	1217	1912	1245	1258													

BLOWER DATA

BELT DRIVE KIT SPECIFICATIONS - 036-074

Model No.	Motor HP		No. of Speeds	Drive Kits and RPM Range					
	Nominal	Maximum		A01	A02	A03	A05	A06	A07
036	0.75	0.86	2	low 449-673 high 673-1010	---	---	---	---	---
	1	1.15	2	---	---	---	low 598-897 high 897-1346	---	---
048	0.75	0.86	2	---	low 497-673 high 745-1117	---	---	---	---
	2	2.3	2	---	---	---	---	low 714-953 high 1071-1429	---
060	1	1.15	2	---	---	low 555-833 high 833-1250	---	---	---
	2	2.3	2	---	---	---	---	---	low 808-1032 high 1212-1548

BELT DRIVE KIT SPECIFICATIONS - 072, 074

Model No.	Motor HP		No. of Speeds			
	Nominal	Maximum		AA01	AA02	AA03
072	1	1.15	1	522-784	---	---
074	2	2.3	1	---	632-875	798-1105

FACTORY INSTALLED OPTIONS/FIELD INSTALLED ACCESSORY AIR RESISTANCE - in. w.g.

Air Volume cfm	Wet Indoor Coil			Humiditrol Dehumidification Coil	Gas Heating		Economizer	Filters	
	036	048	060, 072, 074		Medium Heat	High Heat		MERV 8	MERV 13
036-048 MODELS									
800	0.01	0.01	---	0.00	0.02	0.02	0.04	0.04	0.05
1000	0.02	0.02	---	0.00	0.02	0.02	0.04	0.04	0.07
1200	0.03	0.04	---	0.01	0.02	0.02	0.04	0.04	0.07
1400	0.04	0.05	---	0.02	0.02	0.03	0.04	0.04	0.07
1600	0.05	0.06	---	0.03	0.03	0.04	0.04	0.04	0.07
1800	0.06	0.07	---	0.04	0.04	0.05	0.05	0.04	0.07
2000	0.08	0.09	---	0.04	0.04	0.06	0.05	0.05	0.08
060-074 MODELS									
1000	---	---	0.02	0.00	0.02	0.02	0.04	0.03	0.05
1200	---	---	0.04	0.00	0.02	0.02	0.04	0.03	0.07
1400	---	---	0.05	0.01	0.02	0.03	0.04	0.04	0.07
1600	---	---	0.07	0.02	0.03	0.04	0.04	0.04	0.07
1800	---	---	0.08	0.02	0.03	0.05	0.05	0.05	0.07
2000	---	---	0.10	0.03	0.04	0.06	0.05	0.05	0.07
2200	---	---	0.11	0.04	0.04	0.07	0.05	0.05	0.08
2400	---	---	0.13	0.04	0.05	0.08	0.05	0.05	0.08
2600	---	---	0.15	0.05	0.05	0.09	0.06	0.05	0.08
2800	---	---	0.16	0.05	0.06	0.10	0.06	0.05	0.08
3000	---	---	0.18	0.06	0.07	0.11	0.06	0.05	0.08

POWER EXHAUST FAN PERFORMANCE

Return Air System Static Pressure in. w.g.	Air Volume Exhausted cfm
0.00	2000
0.05	1990
0.10	1924
0.15	1810
0.20	1664
0.25	1507
0.30	1350
0.35	1210

**TABLE 9
MANUFACTURER'S DRIVE COMPONENT NUMBERS**

Drive No.	DRIVE COMPONENTS					
	Motor Pulley		Blower Pulley		Belt	
	Supplier No.	OEM Part No.	Supplier No.	OEM Part No.	Supplier No.	OEM Part No.
A01	1VP34x7/8	31K6901	AK54 x 1	100244-19	A40	100245-17
A02	1VP34x7/8	31K6901	AK49 x 1	100244-18	A39	100245-16
A03	1VP34x7/8	31K6901	AK44 x 1	100244-16	A39	100245-16
A05	1VP34x7/8	31K6901	AK41 x 1	100244-15	A39	100245-16
A06	1VP44x7/8	P-8-1488	AK51 x 1	18L2201	A41	100245-18
A07	1VP50x7/8	P-8-2187	AK54 x 1	100244-19	AX43	73K8201
AA01	1VP34x7/8	31K6901	AK69 x 1	37L4701	AX51	13H0101
AA02	1VP40x7/8	79J0301	BK80H ¹	100788-03	A53	P-8-4951
AA03	1VP40x7/8	79J0301	AK59 x 1	31K6801	A50	100245-29
AA04	1VP44x7/8	P-8-1488	AK59 x 1	31K6801	AX51	13H0101
A01T ²	1VP34x7/8	31K6901	AK54 x 1	100244-19	A41	100245-18
A02T ²	1VP34x7/8	31K6901	AK49 x 1	100244-18	A40	100245-17
A03T ²	1VP34x7/8	31K6901	AK44 x 1	100244-16	A40	100245-17
A05T ²	1VP34x7/8	31K6901	AK41 x 1	100244-15	A41	100245-18
A06T ²	1VP44x7/8	P-8-1488	AK51 x 1	18L2201	A41	100245-18
A07T ²	1VP50x7/8	P-8-2187	AK54 x 1	100244-19	AX43	73K8201
AA01T ²	1VP34x7/8	31K6901	AK69 x 1	37L4701	A50	100245-29
AA02T ²	1VP40x7/8	79J0301	BK80H*	100788-03	A52	100245-30
AA03T ²	1VP40x7/8	79J0301	AK59 x 1	31K6801	A49	100245-32
AA04T ²	1VP44x7/8	P-8-1488	AK59 x 1	31K6801	A50	100245-29

NOTES: ¹ Requires split taper bushing, Browning no. H1; OEM no. 100073-04 ² Includes tension assembly, Fenner no. FS0590; OEM no. 101994-02

Cooling Start-Up

A-Operation

1- Standard and High Efficiency Units -

Initiate first and second stage cooling demands according to instructions provided with Unit Controller Installation and Setup Guide. Use the menu navigation arrows and select button; see SERVICE > TEST

Ultra High Efficiency Units -

Initiate full load cooling operation using the following menu path:

SERVICE > TEST > COOL > COOL 3
(COOL 4 on 074U units)

Note - Refer to Cooling Operation section for ultra high efficiency unit operation in zone sensor mode.

2- No Economizer Installed in Unit -

A first-stage cooling demand (Y1) will energize the compressor and blower in low speed along with the condenser fan. An increased cooling demand (Y2) will increase the blower and compressor to high speed.

Units Equipped With Economizer -

When outdoor air is acceptable, a first-stage

cooling demand (Y1) will energize the economizer. An increased cooling demand (Y2) will energize the compressor and low speed blower along with the condenser fan. When outdoor air is not acceptable unit will operate as though no economizer is installed.

- 3- Units contain one refrigerant circuit or stage.
- 4- Unit is charged with R-410A refrigerant. See unit rating plate for correct amount of charge.
- 5- Refer to Cooling Operation and Adjustment section for proper method to check refrigerant charge.

B-Single Speed, Two-Step and Three Phase Scroll Compressor Voltage Phasing

Note - Does not apply to ultra high efficiency units.

Three phase scroll compressors must be phased sequentially to ensure correct compressor and blower rotation and operation. Compressor and blower are wired in phase at the factory. Power wires are color-coded as follows: line 1-red, line 2-yellow, line 3-blue.

- 1- Observe suction and discharge pressures and blower rotation on unit start-up.
- 2- Suction pressure must drop, discharge pressure must rise, and blower rotation must match rotation marking.

If pressure differential is not observed or blower rotation is not correct:

- 3- Disconnect all remote electrical power supplies.
- 4- Reverse any two field-installed wires connected to the line side of K1 contactor. Do not reverse wires at blower contactor.
- 5- Make sure the connections are tight.

Discharge and suction pressures should operate at their normal start-up ranges.

C-Refrigerant Charge and Check - All-Aluminum Coil
WARNING-Do not exceed nameplate charge under any condition.

This unit is factory charged and should require no further adjustment. If the system requires additional refrigerant, reclaim the charge, evacuate the system, and add required nameplate charge.

*NOTE - System charging is not recommended below 60°F (15°C). In temperatures below 60°F (15°C), the charge **must** be weighed into the system.*

If weighing facilities are not available, or to check the charge, use the following procedure:

IMPORTANT - Charge unit in standard cooling mode high stage only.

- 1- Make sure outdoor coil is clean. Attach gauge manifolds and operate unit at full CFM in cooling mode with economizer disabled until system stabilizes (approximately five minutes). Make sure all outdoor air dampers are closed.
- 2- Compare the normal operating pressures (see tables 10 - 18) to the pressures obtained from the gauges.

Check unit components if there are significant differences.

- 3- Measure the outdoor ambient temperature and the suction pressure. Refer to the appropriate circuit charging curve to determine a target liquid temperature.

Note - Pressures are listed for sea level applications.

- 4- Use the same thermometer to accurately measure the liquid temperature (in the outdoor section).
 - If measured liquid temperature is higher than the target liquid temperature, add refrigerant to the system.
 - If measured liquid temperature is lower than the target liquid temperature, recover some refrigerant from the system.
- 5- Add or remove charge in increments. Allow the system to stabilize each time refrigerant is added or removed.
- 6- Continue the process until measured liquid temperature agrees with the target liquid temperature. Do not go below the target liquid temperature when adjusting charge. Note that suction pressure can change as charge is adjusted.
- 7- Example LGH/LCH036H: At 95°F outdoor ambient and a measured suction pressure of 130psig, the target liquid temperature is 98°F. For a measured liquid temperature of 106°F, add charge in increments until measured liquid temperature agrees with the target liquid temperature.

TABLE 10
LGH/LCH036S/H NORMAL OPERATING PRESSURES - ALL-ALUMINUM COIL

Outdoor Coil Entering Air Temperature											
65 °F		75 °F		85 °F		95 °F		105 °F		115 °F	
Suct (psig)	Disc (psig)	Suct (psig)	Disc (psig)	Suct (psig)	Disc (psig)	Suct (psig)	Disc (psig)	Suct (psig)	Disc (psig)	Suct (psig)	Disc (psig)
114	239	117	279	118	329	119	381	122	441	124	516
121	242	123	284	126	328	128	379	129	442	132	517
138	252	142	291	145	335	148	382	151	434	152	506
156	266	160	301	164	344	168	393	172	446	175	503

**TABLE 11
LGH/LCH036S/H REHEAT NORMAL OPERATING PRESSURES - ALL-ALUMINUM COIL**

Outdoor Coil Entering Air Temperature											
65 °F		75 °F		85 °F		95 °F		105 °F		115 °F	
Suct (psig)	Disc (psig)	Suct (psig)	Disc (psig)	Suct (psig)	Disc (psig)	Suct (psig)	Disc (psig)	Suct (psig)	Disc (psig)	Suct (psig)	Disc (psig)
113	236	116	273	117	316	119	362	119	415	121	480
121	240	124	276	126	318	129	363	130	414	132	475
138	251	142	288	144	330	147	375	150	425	153	482
153	268	159	301	164	342	168	388	171	439	175	496

**TABLE 12
LGH/LCH048S/H NORMAL OPERATING PRESSURES - ALL-ALUMINUM COIL**

Outdoor Coil Entering Air Temperature											
65 °F		75 °F		85 °F		95 °F		105 °F		115 °F	
Suct (psig)	Disc (psig)	Suct (psig)	Disc (psig)	Suct (psig)	Disc (psig)	Suct (psig)	Disc (psig)	Suct (psig)	Disc (psig)	Suct (psig)	Disc (psig)
114	244	117	282	116	329	116	383	118	457	119	551
123	249	125	288	125	332	125	382	127	446	134	486
139	259	142	298	146	341	148	388	148	447	155	499
155	274	161	313	164	357	168	404	171	457	176	511

**TABLE 13
LGH/LCH048S/H REHEAT NORMAL OPERATING PRESSURES - ALL-ALUMINUM COIL**

Outdoor Coil Entering Air Temperature											
65 °F		75 °F		85 °F		95 °F		105 °F		115 °F	
Suct (psig)	Disc (psig)	Suct (psig)	Disc (psig)	Suct (psig)	Disc (psig)	Suct (psig)	Disc (psig)	Suct (psig)	Disc (psig)	Suct (psig)	Disc (psig)
112	250	115	288	118	331	120	380	119	445	121	533
122	254	124	292	127	333	126	391	129	447	130	551
139	264	143	302	146	344	149	392	151	444	154	502
157	280	161	318	166	360	170	406	173	457	176	512

**TABLE 14
LGH/LCH060S/H NORMAL OPERATING PRESSURES - ALL-ALUMINUM COIL**

Outdoor Coil Entering Air Temperature											
65 °F		75 °F		85 °F		95 °F		105 °F		115 °F	
Suct (psig)	Disc (psig)	Suct (psig)	Disc (psig)	Suct (psig)	Disc (psig)	Suct (psig)	Disc (psig)	Suct (psig)	Disc (psig)	Suct (psig)	Disc (psig)
111	238	114	274	115	316	117	364	119	420	121	488
128	233	122	278	124	320	126	367	128	422	130	486
137	253	141	292	144	329	146	375	148	427	150	486
154	267	160	300	163	344	167	389	170	438	173	494

**TABLE 15
LGH/LCH060S/H REHEAT NORMAL OPERATING PRESSURES - ALL-ALUMINUM COIL**

Outdoor Coil Entering Air Temperature											
65 °F		75 °F		85 °F		95 °F		105 °F		115 °F	
Suct (psig)	Disc (psig)	Suct (psig)	Disc (psig)	Suct (psig)	Disc (psig)	Suct (psig)	Disc (psig)	Suct (psig)	Disc (psig)	Suct (psig)	Disc (psig)
112	248	114	285	115	327	117	378	119	436	122	500
121	253	124	289	125	331	127	378	129	432	131	496
139	264	142	301	145	342	147	390	149	445	151	508
158	280	162	315	166	356	170	402	173	452	177	509

**TABLE 16
LGH/LCH072H NORMAL OPERATING PRESSURES - ALL-ALUMINUM COIL**

Outdoor Coil Entering Air Temperature											
65 °F		75 °F		85 °F		95 °F		105 °F		115 °F	
Suct (psig)	Disc (psig)	Suct (psig)	Disc (psig)	Suct (psig)	Disc (psig)	Suct (psig)	Disc (psig)	Suct (psig)	Disc (psig)	Suct (psig)	Disc (psig)
113	261	115	300	116	347	118	402	119	492	123	512
122	266	124	307	126	349	126	402	128	467	132	518
140	277	143	316	145	360	147	411	149	472	151	540
159	291	161	329	164	375	168	423	172	478	174	537

**TABLE 17
LGH/LCH072H REHEAT NORMAL OPERATING PRESSURES - ALL-ALUMINUM COIL**

Outdoor Coil Entering Air Temperature											
65 °F		75 °F		85 °F		95 °F		105 °F		115 °F	
Suct (psig)	Disc (psig)	Suct (psig)	Disc (psig)	Suct (psig)	Disc (psig)	Suct (psig)	Disc (psig)	Suct (psig)	Disc (psig)	Suct (psig)	Disc (psig)
109	260	111	300	112	348	114	403	118	459	119	524
122	270	120	304	121	351	124	405	126	463	128	526
135	279	139	318	142	362	144	408	145	470	148	540
154	299	158	336	162	378	165	425	169	476	172	533

**TABLE 18
LGH/LCH074H NORMAL OPERATING PRESSURES - ALL-ALUMINUM COIL**

Outdoor Coil Entering Air Temperature											
65 °F		75 °F		85 °F		95 °F		105 °F		115 °F	
Suct (psig)	Disc (psig)	Suct (psig)	Disc (psig)	Suct (psig)	Disc (psig)	Suct (psig)	Disc (psig)	Suct (psig)	Disc (psig)	Suct (psig)	Disc (psig)
112	257	113	298	114	348	116	403	118	476	121	602
120	261	122	301	123	347	124	403	127	466	129	556
136	271	140	310	143	354	145	401	145	460	147	525
154	290	157	327	161	370	165	416	168	468	171	526

**TABLE 19
LGH/LCH074H REHEAT NORMAL OPERATING PRESSURES - ALL-ALUMINUM COIL**

Outdoor Coil Entering Air Temperature											
65 °F		75 °F		85 °F		95 °F		105 °F		115 °F	
Suct (psig)	Disc (psig)	Suct (psig)	Disc (psig)	Suct (psig)	Disc (psig)	Suct (psig)	Disc (psig)	Suct (psig)	Disc (psig)	Suct (psig)	Disc (psig)
113	261	113	301	116	349	117	403	119	463	121	521
121	266	123	305	124	351	126	404	128	460	130	538
139	248	143	285	146	326	148	372	148	467	151	532
158	300	161	336	165	379	170	428	173	478	175	537

LGH/LCH036S/H CHARGING CURVE - ALL-ALUMINUM COIL

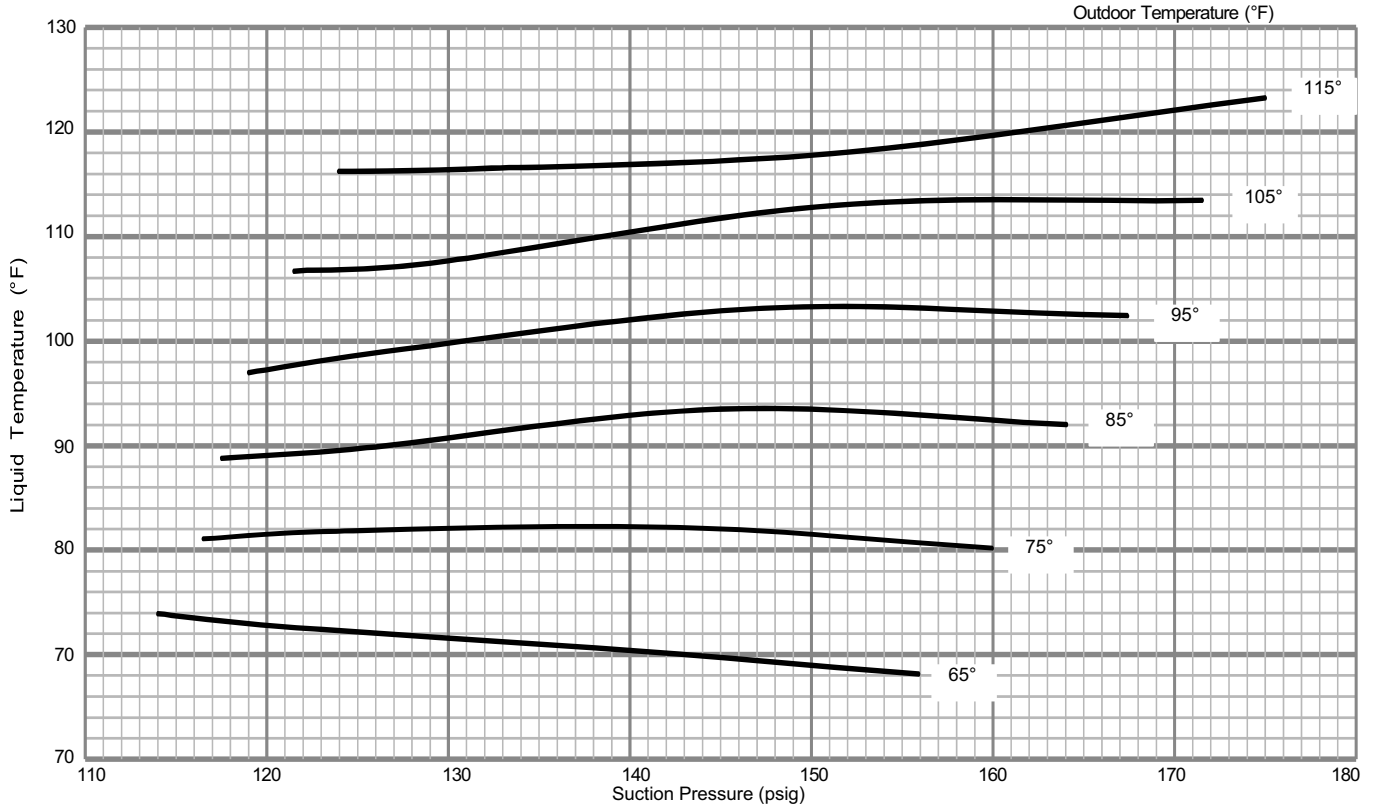

LGH/LCH036S/H REHEAT CHARGING CURVE - ALL-ALUMINUM COIL

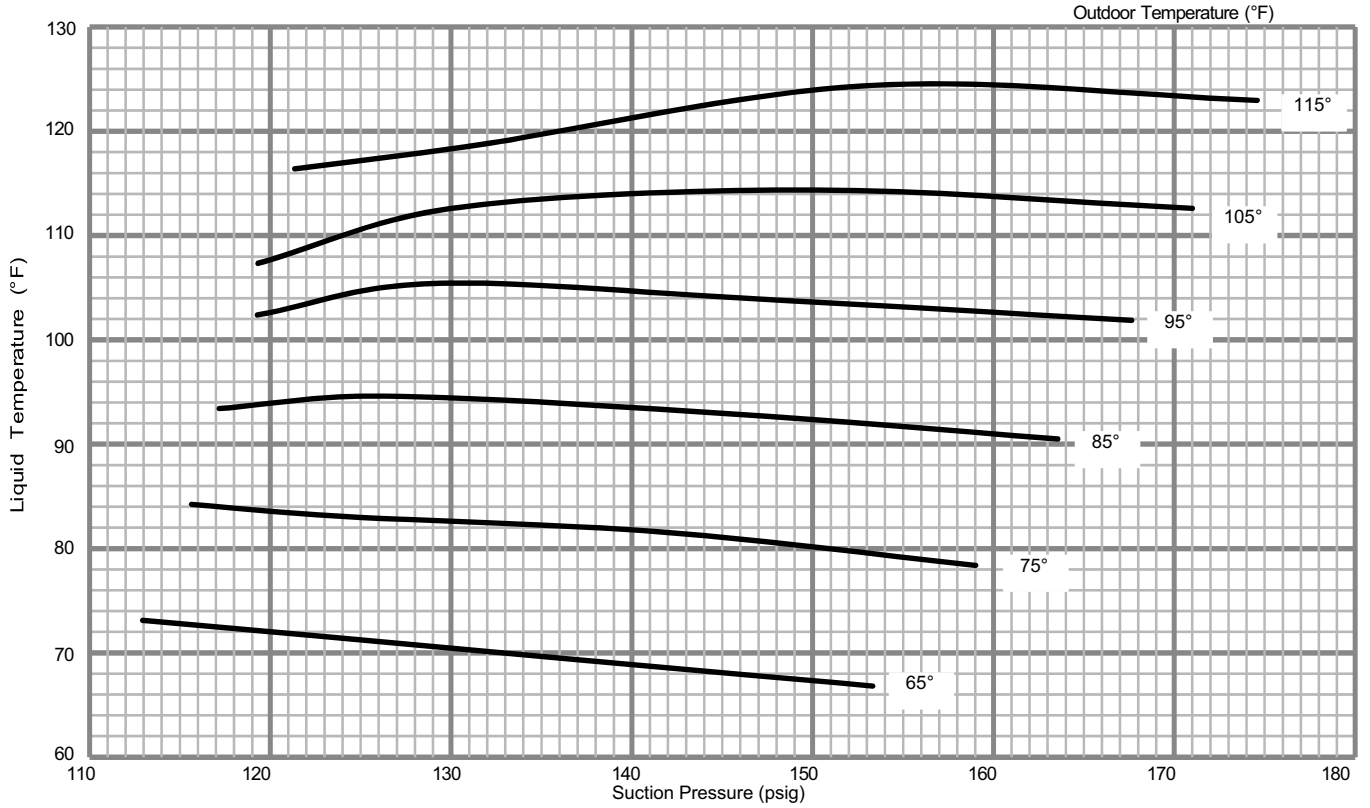

LGH/LCH048S/H CHARGING CURVE - ALL-ALUMINUM COIL

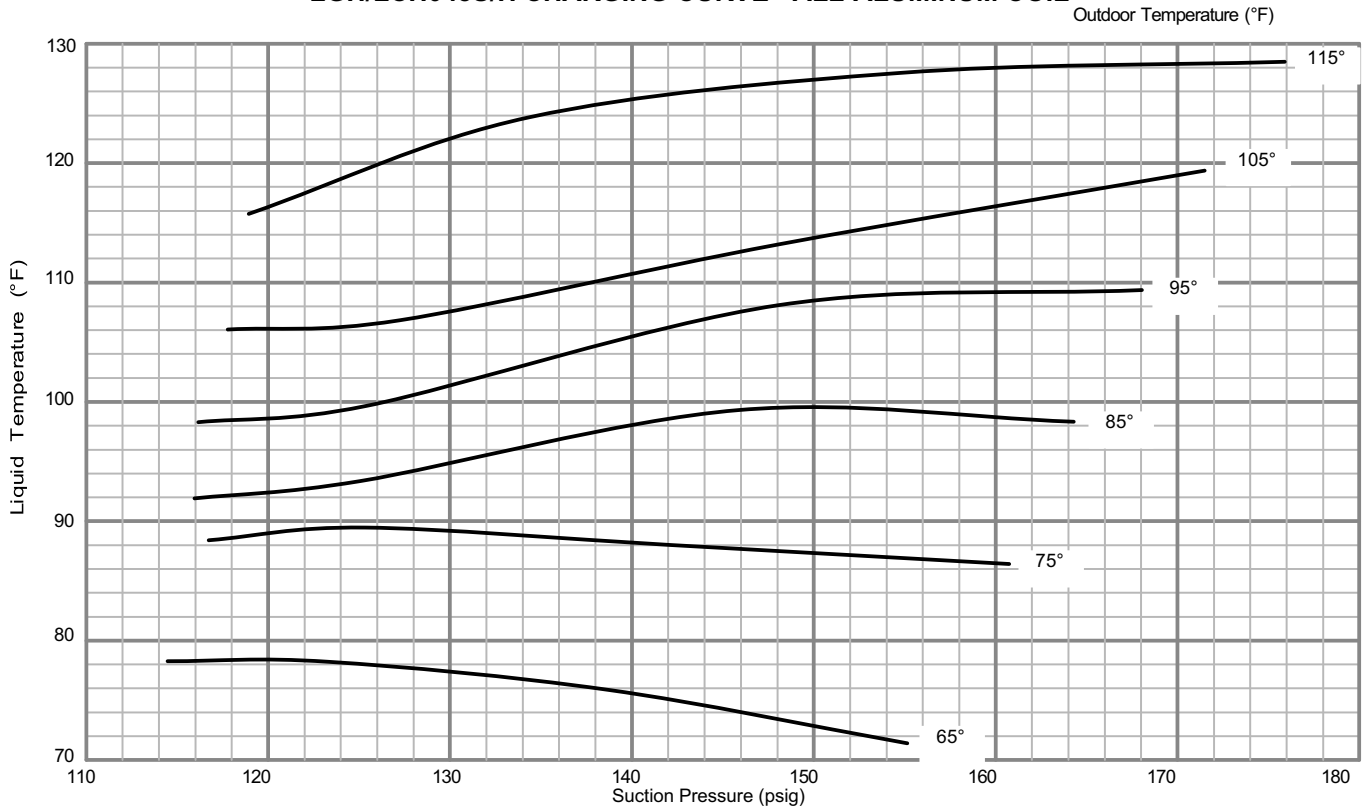

LGH/LCH048S/H REHEAT CHARGING CURVE - ALL-ALUMINUM COIL

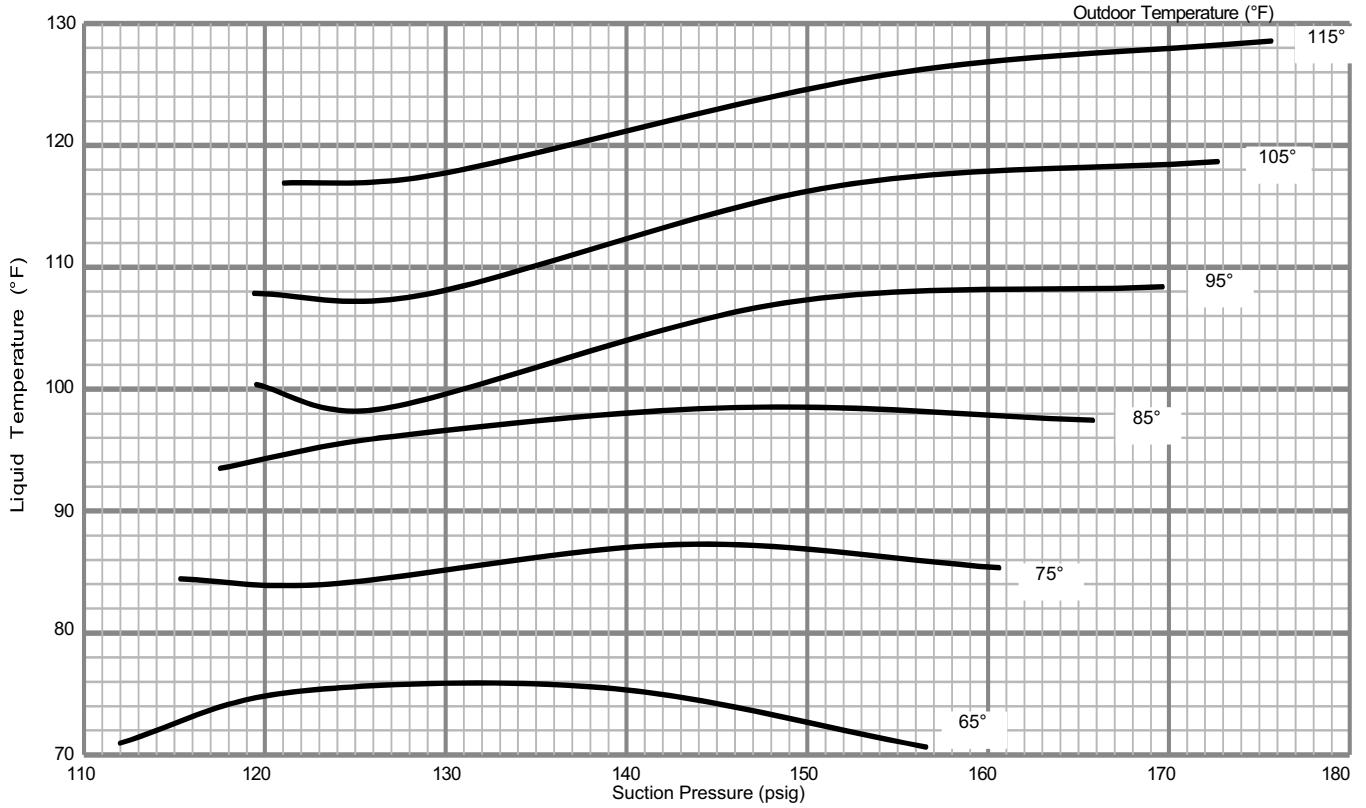

LGH/LCH060S/H CHARGING CURVE - ALL-ALUMINUM COIL

Outdoor Temperature (°F)

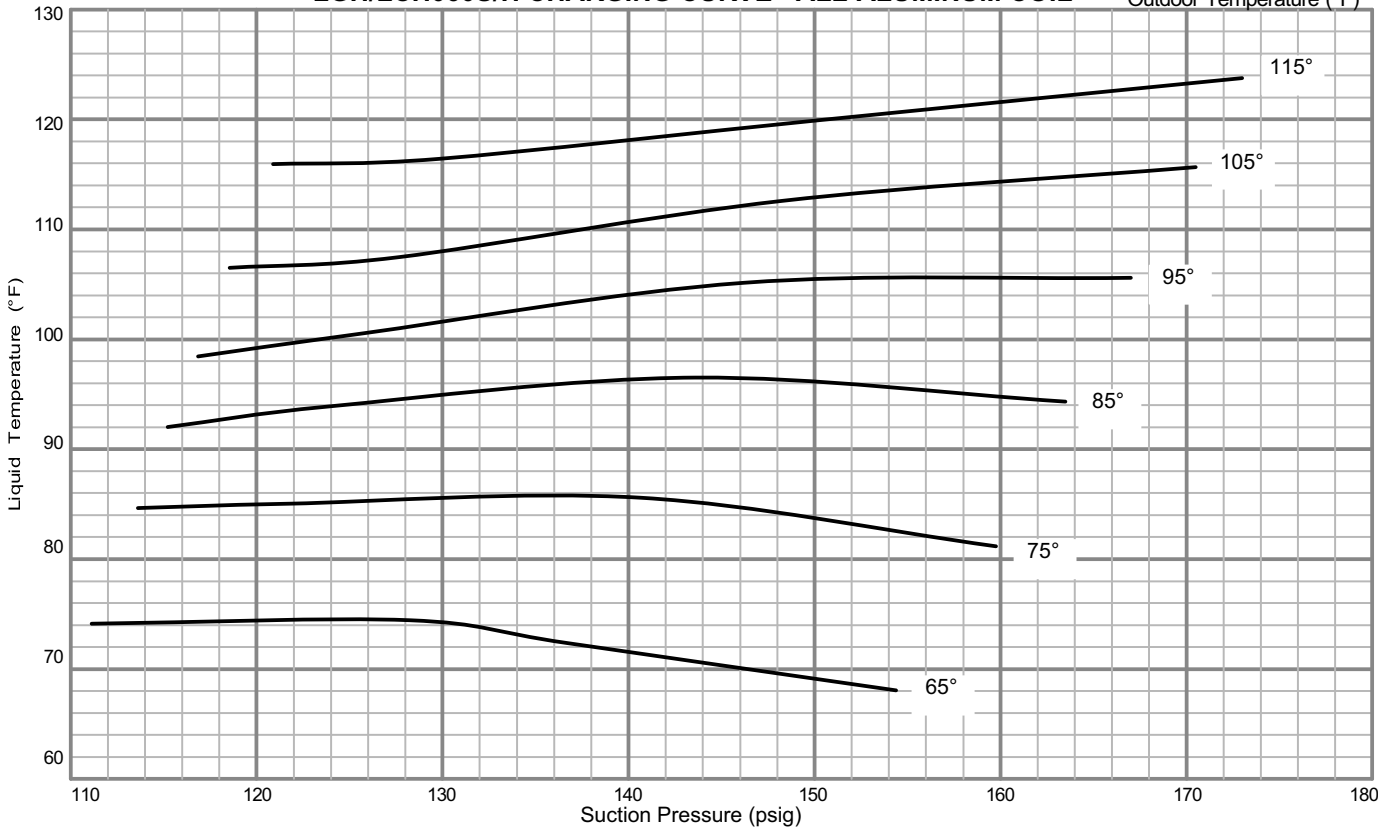

LGH/LCH060S/H REHEAT CHARGING CURVE - ALL-ALUMINUM COIL

Outdoor Temperature (°F)

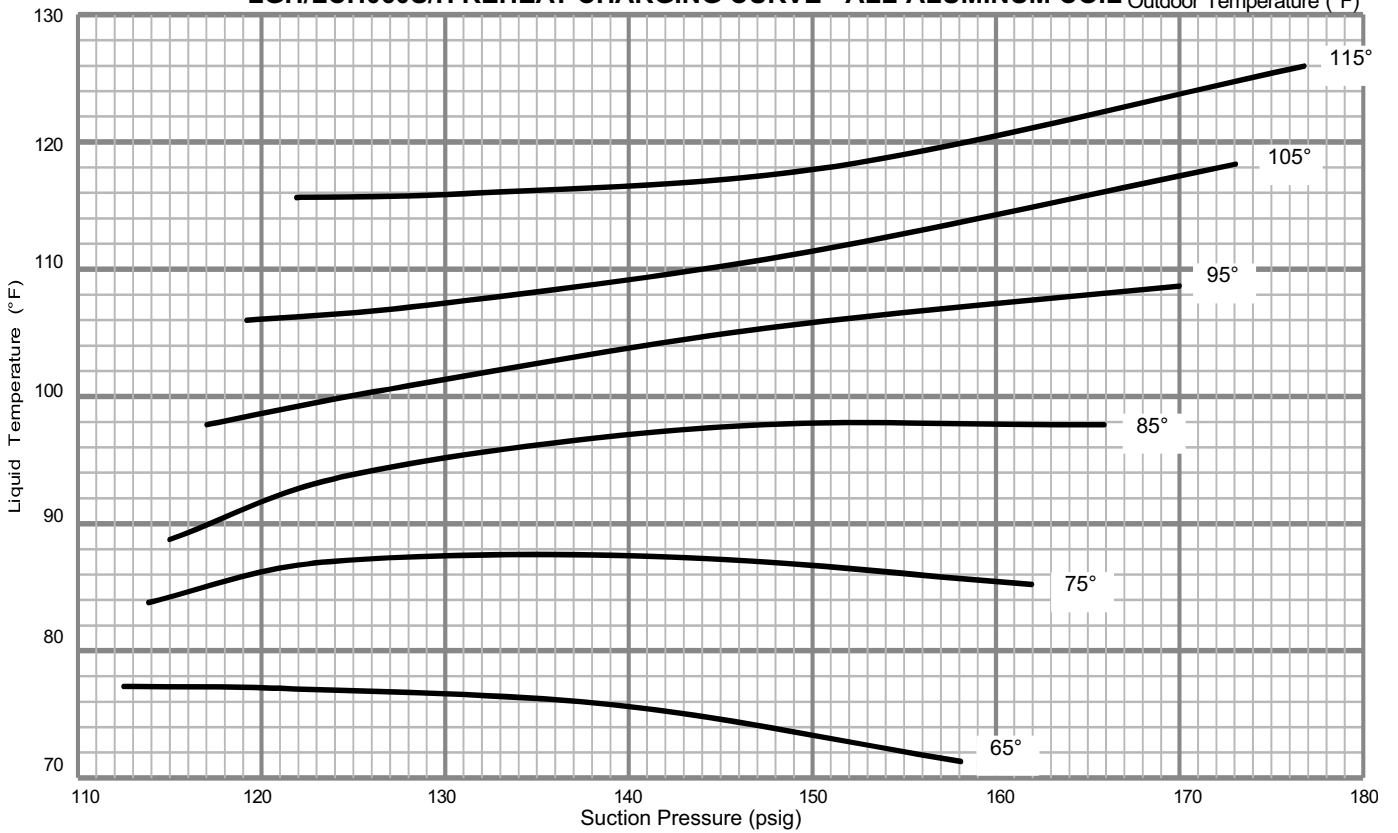

LGH/LCH072H CHARGING CURVE - ALL-ALUMINUM COIL

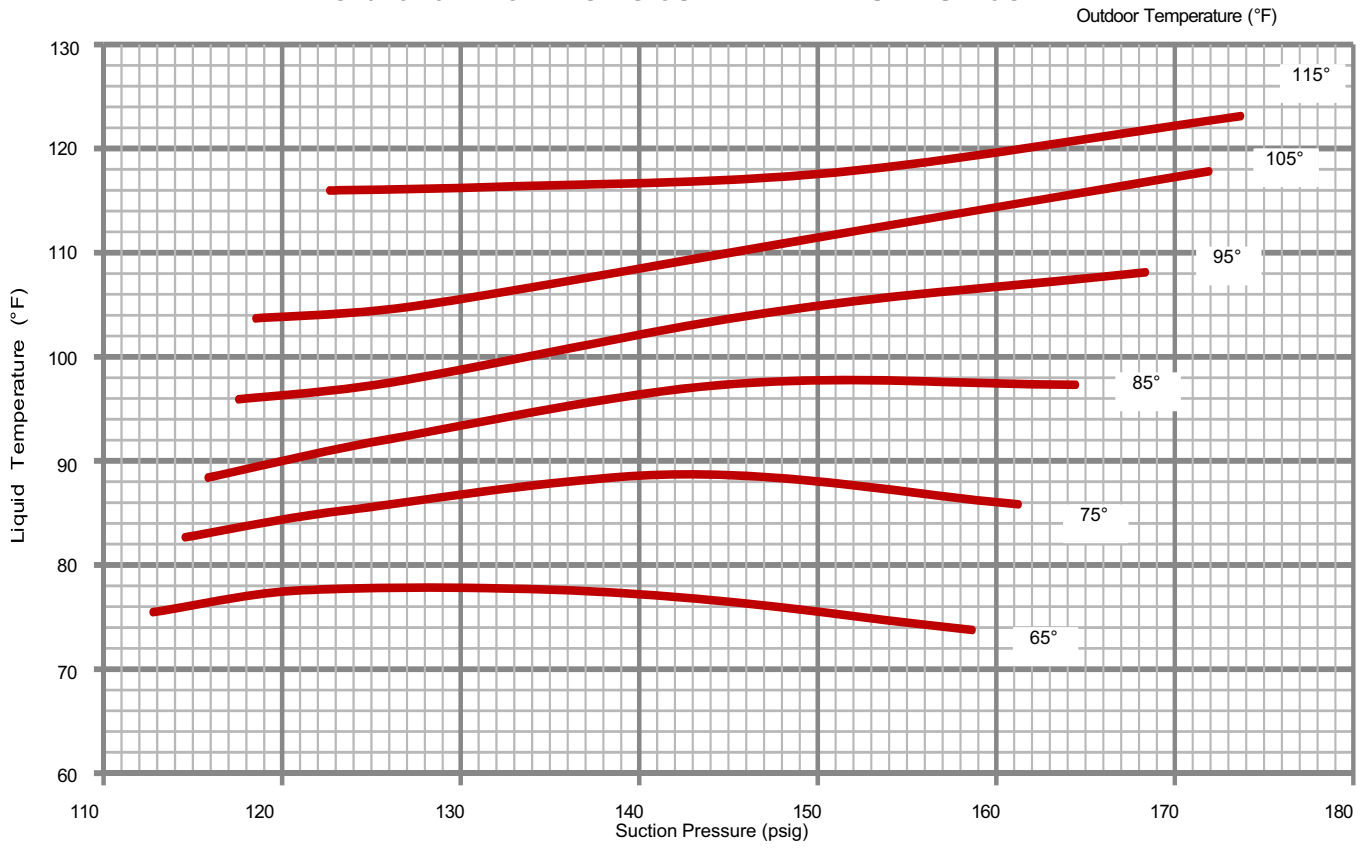

LGH/LCH072H REHEAT CHARGING CURVE - ALL-ALUMINUM COIL

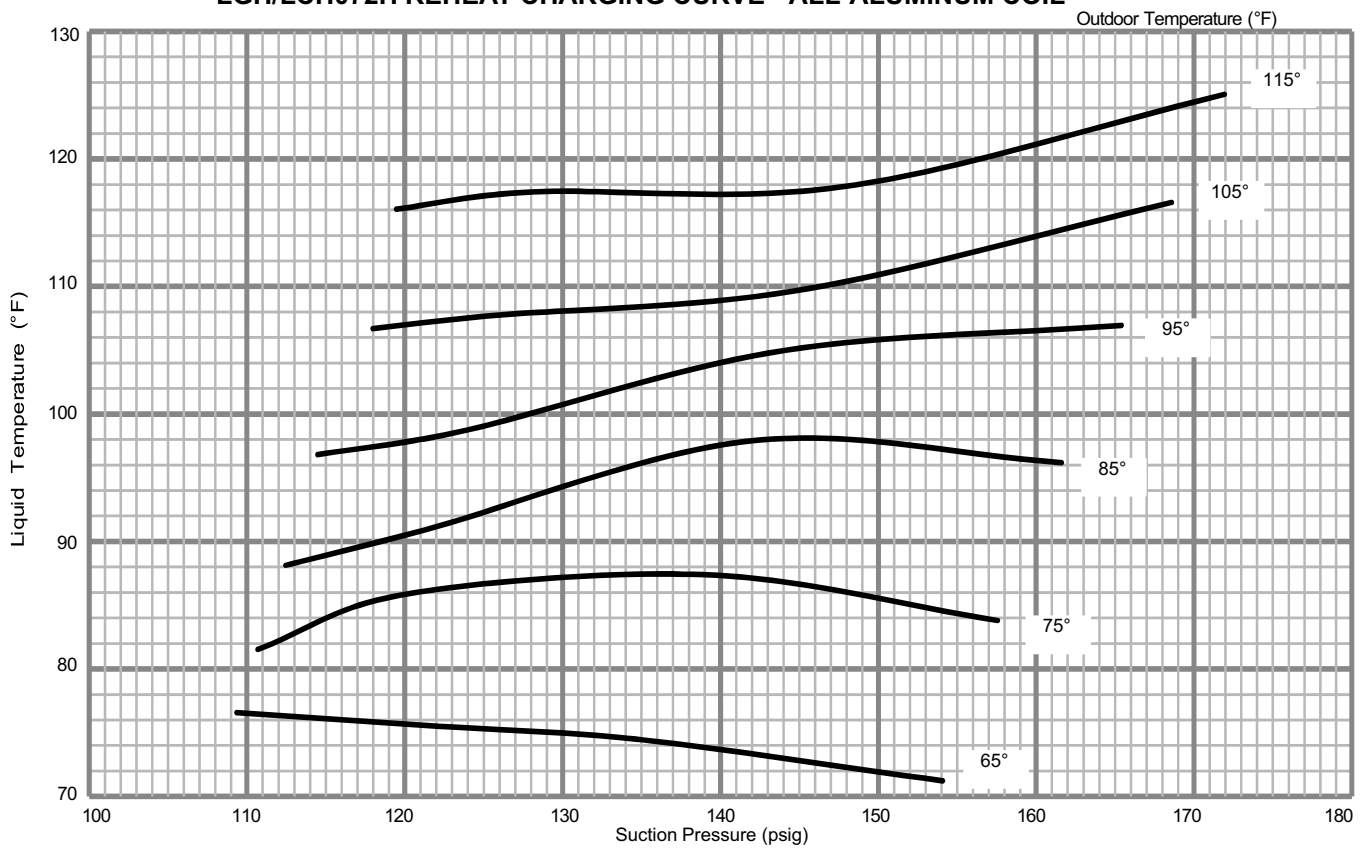

LGH/LCH074H CHARGING CURVE - ALL-ALUMINUM COIL

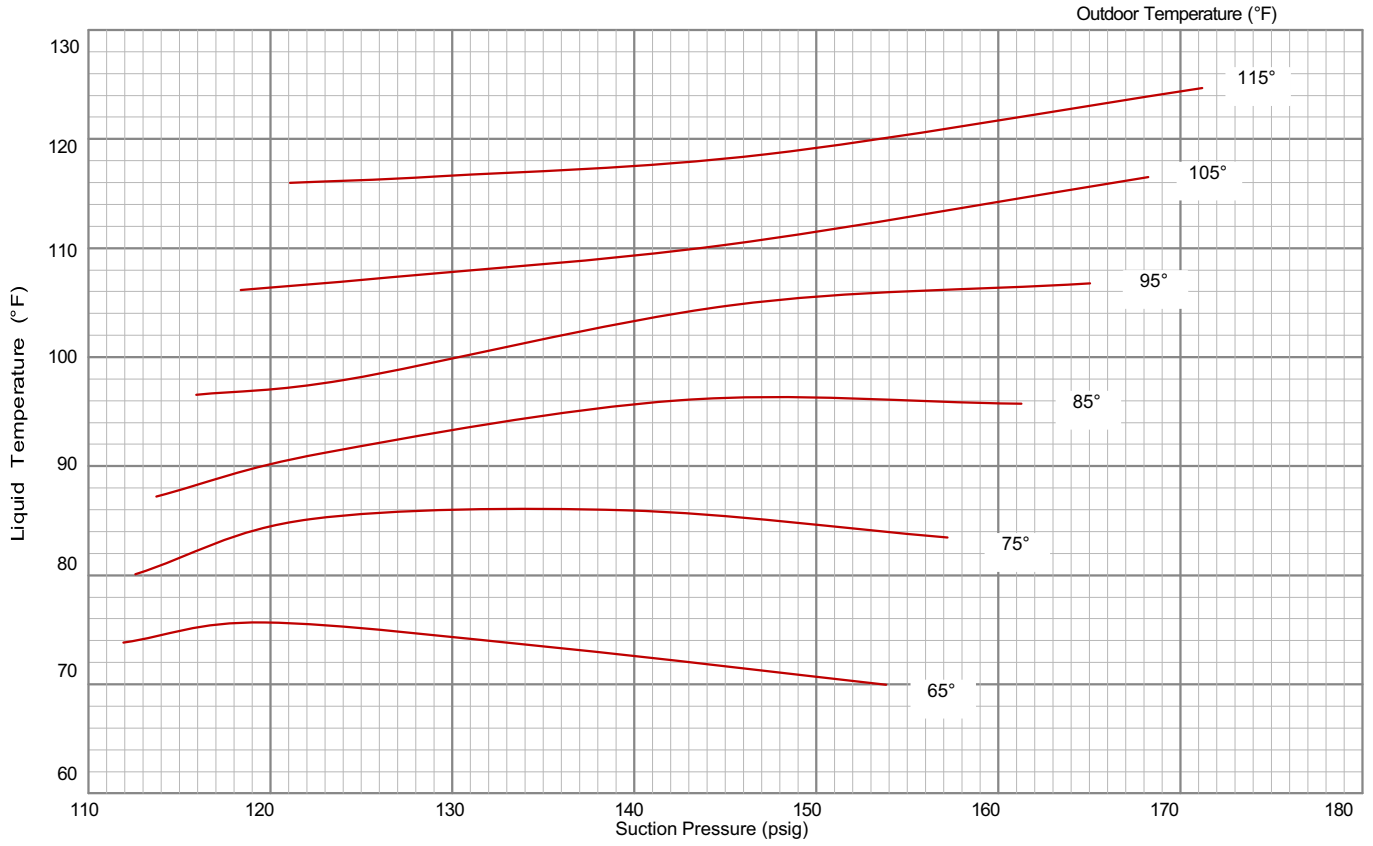

LGH/LCH074H REHEAT CHARGING CURVE - ALL-ALUMINUM COIL

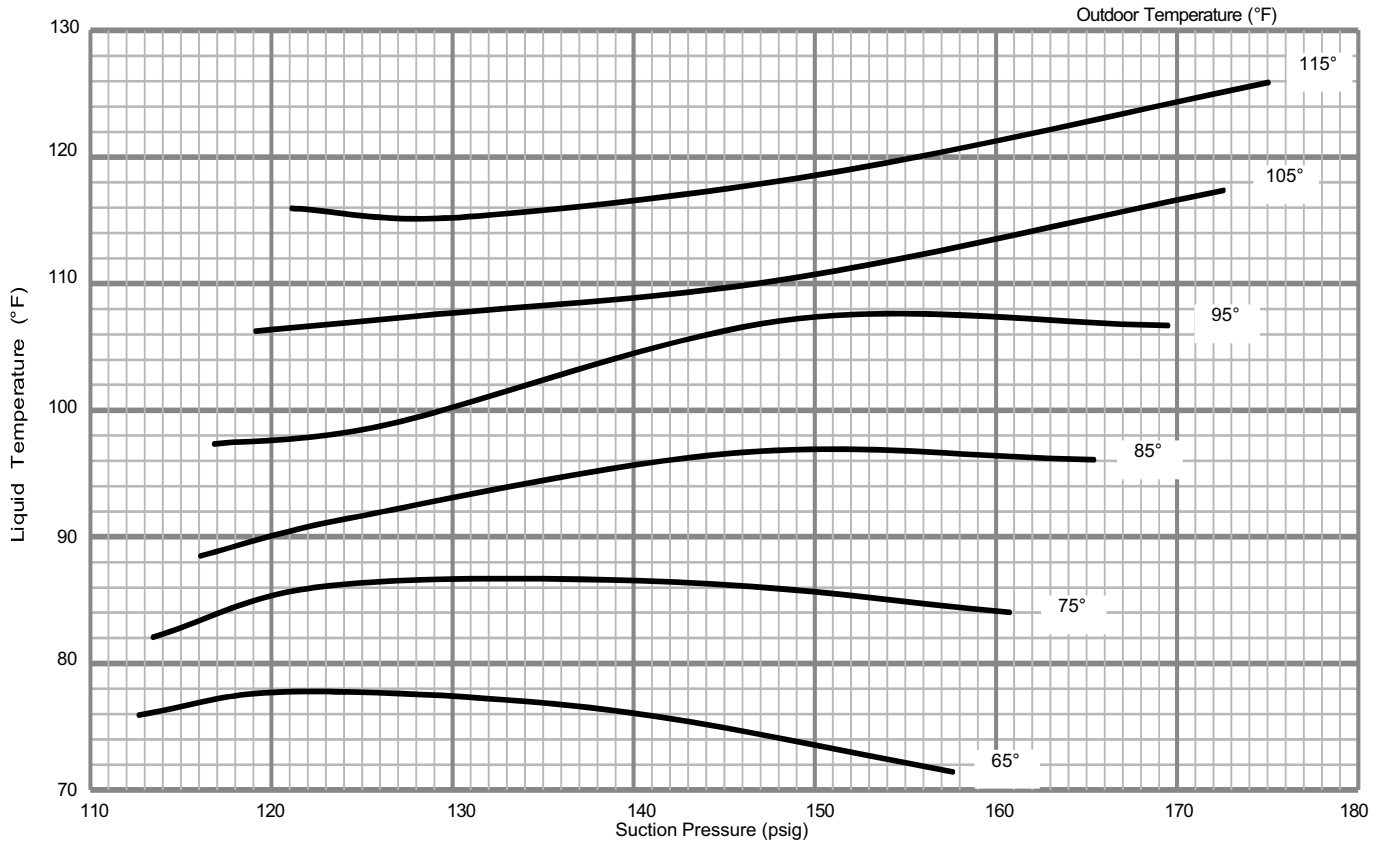

D-Refrigerant Charge and Check - Fin/Tube Coil

WARNING-Do not exceed nameplate charge under any condition.

This unit is factory charged and should require no further adjustment. If the system requires additional refrigerant, reclaim the charge, evacuate the system, and add required nameplate charge.

*NOTE - System charging is not recommended below 60°F (15°C). In temperatures below 60°F (15°C), the charge **must** be weighed into the system.*

If weighing facilities are not available, or to check the charge, use the following procedure:

- 1- Attach gauge manifolds and operate unit in cooling mode on **HIGH SPEED** with economizer disabled until system stabilizes (approximately five minutes). Make sure outdoor air dampers are closed.

Note - On Ultra high efficiency units, use Unit Controller menu path SERVICE > TEST > COOL > COOL 3 for 036, 048 and 060U units. Use COOL 4 for 074U units.

- 2- Use a thermometer to accurately measure the outdoor ambient temperature.
- 3- Apply the outdoor temperature to tables 20 through 32 to determine normal operating pressures. Pressures are listed for sea level applications at 80°F dry bulb and 67°F wet bulb return air.
- 4- Compare the normal operating pressures to the pressures obtained from the gauges. Minor variations in these pressures may be expected due to differences in installations. Significant differences could mean that the system is not properly charged or that a problem exists with some component in the system. **Correct any system problems before proceeding.**
- 5- If discharge pressure is high, remove refrigerant from the system. If discharge pressure is low, add refrigerant to the system.

- Add or remove charge in increments.
- Allow the system to stabilize each time refrigerant is added or removed.

- 6- Use one of the following charge verification methods along with the normal operating pressures to confirm readings.

E-Charge Verification - Fin/Tube Coil - AHRI TESTING

Approach Method - Standard and High Efficiency Units

- 1- Using the same thermometer, compare liquid temperature to outdoor ambient temperature.
Approach Temperature = Liquid temperature (at condenser outlet) minus ambient temperature.
- 2- Approach temperature should match values in table 33. An approach temperature greater than value shown indicates an undercharge. An approach temperature less than value shown indicates an overcharge.

- 3- The approach method is not valid for grossly over or undercharged systems. Use tables 20 through 32 as a guide for typical operating pressures.

Subcooling Method - Ultra High Efficiency Units

- 1- Attach gauge manifold to the liquid line. With the economizer disabled, operate the unit in **cooling mode at high speed** using the following Unit Controller menu path:

SERVICE > TEST > COOL > COOL 3
(COOL 4 on 074U units)

- 2- Use the liquid line pressure and a PT chart to determine the saturated liquid temperature.
- 3- Measure the liquid line temperature at the condenser outlet.

Subcooling Temperature = Liquid Saturated Temperature Minus Liquid Temperature.

- 4- The subcooling temperature should be as shown in figure 34. A subcooling temperature greater than this value indicates an overcharge. A subcooling temperature less than this value indicates an undercharge.

**TABLE 20
LG/LC 036S/H NORMAL OPERATING PRESSURES**

Outdoor Coil Entering Air Temp	Discharge ±10 psig	Suction ± 5 psig
65° F	265	140
75° F	299	143
85° F	348	145
95° F	394	148
105° F	445	150
115° F	500	153

**TABLE 21
LG/LC 036S/H REHEAT NORMAL OPERATING PRESSURES**

Outdoor Coil Entering Air Temp	Discharge ±10 psig	Suction ± 5 psig
65° F	262	139
75° F	300	141
85° F	342	144
95° F	388	148
105° F	437	150
115° F	491	153

**TABLE 22
LG/LC 036U NORMAL OPERATING PRESSURES**

Outdoor Coil Entering Air Temp	Discharge ±10 psig	Suction ± 5 psig
65° F	238	146
75° F	277	149
85° F	317	150
95° F	363	151
105° F	416	151
115° F	474	154

TABLE 23
LG/LC 048S/H NORMAL OPERATING PRESSURES

Outdoor Coil Entering Air Temp	Discharge ±10 psig	Suction ± 5 psig
65° F	258	126
75° F	299	135
85° F	343	143
95° F	389	147
105° F	440	154
115° F	495	157

TABLE 24
LG/LC 048S/H REHEAT NORMAL OPERATING PRESSURES

Outdoor Coil Entering Air Temp	Discharge ±10 psig	Suction ± 5 psig
65° F	260	139
75° F	299	142
85° F	341	145
95° F	389	148
105° F	440	151
115° F	496	154

TABLE 25
LG/LC 048U NORMAL OPERATING PRESSURES

Outdoor Coil Entering Air Temp	Discharge ±10 psig	Suction ± 5 psig
65° F	252	142
75° F	289	145
85° F	332	147
95° F	379	149
105° F	428	151
115° F	484	153

TABLE 26
LG/LC 060S/H NORMAL OPERATING PRESSURES

Outdoor Coil Entering Air Temp	Discharge ±10 psig	Suction ± 5 psig
65° F	253	135
75° F	291	138
85° F	333	141
95° F	379	145
105° F	428	148
115° F	481	151

TABLE 27
LG/LC 060S/H REHEAT NORMAL OPERATING PRESSURES

Outdoor Coil Entering Air Temp	Discharge ±10 psig	Suction ± 5 psig
65° F	263	139
75° F	300	142
85° F	339	143
95° F	383	146
105° F	431	148
115° F	483	151

TABLE 28
LG/LC 060U NORMAL OPERATING PRESSURES

Outdoor Coil Entering Air Temp	Discharge ±10 psig	Suction ± 5 psig
65° F	261	135
75° F	299	138
85° F	341	140
95° F	388	142
105° F	441	144
115° F	499	146

TABLE 29
LG/LC 072H NORMAL OPERATING PRESSURES

Outdoor Coil Entering Air Temp	Discharge ±10 psig	Suction ± 5 psig
65° F	271	136
75° F	312	139
85° F	357	141
95° F	405	144
105° F	458	147
115° F	515	151

TABLE 30
LG/LC 072H REHEAT NORMAL OPERATING PRESSURES

Outdoor Coil Entering Air Temp	Discharge ±10 psig	Suction ± 5 psig
65° F	272	137
75° F	312	139
85° F	356	140
95° F	403	142
105° F	453	145
115° F	507	148

TABLE 31
LG/LC 074H STD. & REHEAT NORMAL OPERATING PRESSURES

Outdoor Coil Entering Air Temp	Discharge ±10 psig	Suction ± 5 psig
65° F	287	139
75° F	325	141
85° F	366	143
95° F	411	146
105° F	460	149
115° F	513	152

TABLE 32
LG/LC 074U NORMAL OPERATING PRESSURES

Outdoor Coil Entering Air Temp	Discharge ±10 psig	Suction ± 5 psig
65° F	268	128
75° F	307	134
85° F	351	137
95° F	399	140
105° F	450	142
115° F	505	144

**TABLE 33
APPROACH TEMPERATURE**

LGH/LCH Unit	Liquid Temp. Minus Ambient Temp.
036S & H Std.; 036S & H Reheat; 048S & H Std.; 072H Std.; 074H Std.	6°F ± 1 (3.3°C ± 0.5)
048S & H Reheat; 072H Reheat; 074H Reheat	7°F ± 1 (3.9°C ± 0.5)
060S & H Std.; 060S/H Reheat	8°F ± 1 (4.4°C ± 0.5)

**TABLE 34
SUBCOOLING TEMPERATURE**

LGH/LCH Unit	Liquid Saturated Temp. Minus Liquid Temperature
036U; 060U	15°F ± 1 (8.3°C ± 0.5)
048U	15.5°F ± 1 (8.6°C ± 0.5)
074U	16°F ± 1 (8.8°C ± 0.5)

F-Compressor Controls

See unit wiring diagram to determine which controls are used on each unit. Optional controls are identified on wiring diagrams by arrows at junction points.

- 1- High Pressure Switch (S4)
The compressor circuit is protected by a high pressure switch which opens at 640 psig ± 10 psig (4413 kPa ± 70 kPa) and automatically resets at 475 psig ± 20 psig (3275kPa ± 138 kPa).
- 2- Low Pressure Switch (S87)
The compressor circuit is protected by a loss of charge switch. Switch opens at 40 psig ± 5 psig (276 ± 34 kPa) and automatically resets at 90 psig ± 5 psig (621 kPa ± 34 kPa).
- 3- Freezestat (S49)
The compressor is protected by a freezestat located on the indoor coil. The freezestat opens at 29°F±3 (-2°C±2) and closes at 58°F±4 (14°C±2).
- 4- Compressor Crankcase Heater (HR1)
Crankcase heater must be energized at all times to prevent compressor damage due to refrigerant migration. Energize crankcase heater 24 hours before unit start-up by setting thermostat so that there is no cooling demand (to prevent compressor from cycling) and apply power to unit.
- 5- Low Ambient Pressure Switch (S11)
Switch maintains adequate discharge pressure by de-energizing condenser fan when liquid pressure falls below 240 psig ±10 (1655 kPa±69). S11 is installed in the liquid line. Switch closes to energize condenser fan when pressure rises to 450 psig ±10 (3103kPa ± 69).

- 6- Discharge Line Thermostat (S40)
3 through 5 Ton Non-Ultra Units Only
Switch opens when discharge line temperature reaches 94°F±5 (34°C±3) and closes when temperature falls below 74°F±5 (23°C±3). Prevents crankcase heater operation in warm weather.

- 7- High Ambient Pressure Switch (S16)
Switch improves high ambient operation by activating the TXV assist circuit. Switch closes at 550psig ± 10 (3792kPa ± 70kPa) and automatically resets at 400 PSIG (2758kPa ± 70kPa).

Cooling Operation

036S/H, 048S/H, 060S/H, 074H UNITS

This is a summary of cooling operation. Refer to the sequence of operation provided in the Engineering Handbook or Service Manual for more detail.

Note - During a dehumidification demand the blower operates at low speed. Free cooling is locked-out during reheat operation. Refer to hot gas reheat start-up and operation section for details.

A-Two-Stage Thermostat

1-Economizer With Outdoor Air Suitable

Y1 Demand -
Compressor Off
Blower Low
Dampers modulate

Y2 Demand -
Compressor Off
Blower High
Dampers Modulate

Note - If dampers are at maximum open for three minutes, compressor is energized at high speed and blower stays on cooling high.

2-No Economizer or Outdoor Air Not Suitable

Y1 Demand -
Compressor Low
Blower Low
Dampers Minimum Position

Y2 Demand -
Compressor High
Blower High
Dampers Minimum Position

B-Three-Stage Thermostat OR Room Sensor

1-Economizer With Outdoor Air Suitable

Y1 Demand -
Compressors Off
Blower Cooling Low
Dampers modulate

Y2 Demand -
Compressors Off
Blower Cooling High
Dampers Modulate

Note - If dampers are at maximum open for three minutes, compressor 1 is energized and blower stays on cooling high.

Y3 Demand -
Compressors 1 and 2 On
Blower High
Dampers Maximum Open

072H UNITS

This is a summary of cooling operation. Refer to the sequence of operation provided in the Engineering Handbook or Service Manual for more detail.

Note - During a dehumidification demand the blower operates at low speed. Free cooling is locked-out during reheat operation. Refer to hot gas reheat start-up and operation section for details.

A-Two-Stage Thermostat

1-Economizer With Outdoor Air Suitable

Y1 Demand -
Compressors Off
Blower Cooling On
Dampers modulate

Note - If dampers are at maximum open for three minutes, compressor is energized.

Y2 Demand -
Compressors On
Blower Cooling On
Dampers Modulate

2-No Economizer or Outdoor Air Not Suitable

Y1 Demand -
Compressor 1 On
Blower Cooling On
Dampers Minimum Position

036U, 048U, 060U, 074U UNITS

A-Two-Stage Thermostat

1-Economizer With Outdoor Air Suitable

Y1 Demand -
Compressor Off
Blower Low
Dampers modulate

Y2 Demand -
Compressor Low
Blower Low
Dampers Full Open

Note - Compressor is energized after damper has been at full open for three minutes.

2-No Economizer or Outdoor Air Not Suitable

Y1 Demand -
Compressor Low
Blower Low
Dampers Minimum Position

Y2 Demand -
Compressor High
Blower High
Dampers Minimum Position

B-Three-Stage Thermostat OR Room Sensor

1-Economizer With Outdoor Air Suitable

Y1 Demand -
Compressors Off
Blower Low
Dampers Modulate

Y2 Demand -
Compressor Low
Blower Low
Dampers Full Open

Note - Compressor is energized after damper has been at full open for three minutes.

Y3 Demand -
Compressor High
Blower High
Dampers Full Open

2-No Economizer or Outdoor Air Not Suitable

Y1 Demand -
Compressor Low
Blower Low
Dampers Minimum Position

Y2 Demand -
Compressor High
Blower High
Dampers Minimum Position

Y3 Demand -
Compressor High
Blower High
Dampers Minimum Position

C-Zone Sensor

1-Economizer With Outdoor Air Suitable

Low Cooling Demand -

Compressor Off

Blower Variable

Dampers Modulate

High Cooling Demand -

Compressor Variable

Blower Variable

Dampers Full Open

Note - Compressor is energized after damper has been at full open for three minutes.

Note - Free cooling is locked out when a dehumidification demand is received. The unit operates in dehumidification mode as if the outdoor air is not suitable.

2-No Economizer or Outdoor Air Not Suitable

Any Demand -

Compressor Variable

Blower Variable

Damper Minimum Position

D-Verify Proper Operation In Zone Sensor Mode

The Unit Controller (A55) communicates the appropriate frequency (speed) to the compressor inverter (A192) to match the cooling load. Because the cooling load varies, the Unit Controller provides a test mode to initiate a predictable compressor speed. Use the following Unit Controller menu paths to change the compressor speed and verify discharge and suction pressures are changing appropriately. When the compressor speed **increases**, the discharge pressure will **increase** proportionately and the suction pressure will **decrease** proportionately. When the compressor speed **decreases**, the discharge pressure will **decrease** proportionately and the suction pressure will **increase** proportionately.

036, 048, 060U

High speed compressor operation:

SERVICE > TEST > COOL > COOL 3

Intermediate speed compressor operation:

SERVICE > TEST > COOL > COOL 2

Low speed compressor operation

SERVICE > TEST > COOL > COOL 1

074U Only

High speed compressor operation:

SERVICE > TEST > COOL > COOL 4

First intermediate speed compressor operation:

SERVICE > TEST > COOL > COOL 3

Second intermediate speed compressor operation:

SERVICE > TEST > COOL > COOL 2

Low speed compressor operation

SERVICE > TEST > COOL > COOL 1

Gas Heat Start-Up (Gas Units)

FOR YOUR SAFETY READ BEFORE LIGHTING

⚠️ WARNING



Electric shock hazard. Can cause injury or death. Do not use this unit if any part has been under water. Immediately call a qualified service technician to inspect the unit and to replace any part of the control system and any gas control which has been under water.

⚠️ WARNING



Danger of explosion. Can cause injury or product or property damage. If overheating occurs or if gas supply fails to shut off, shut off the manual gas valve to the appliance before shutting off electrical supply.

⚠️ WARNING



Electric shock hazard. Can cause injury or death. Before attempting to perform any service or maintenance, turn the electrical power to unit OFF at disconnect switch(es). Unit may have multiple power supplies.

⚠️ WARNING

SMOKE POTENTIAL

The heat exchanger in this unit could be a source of smoke on initial firing. Take precautions with respect to building occupants and property. Vent initial supply air outside when possible.

BEFORE LIGHTING smell all around the appliance area for gas. Be sure to smell next to the floor because some gas is heavier than air and will settle on the floor.

The gas valve may be equipped with either a gas control lever or gas control knob. Use only your hand to push the lever or turn the gas control knob. Never use tools. If the the lever will not move or the knob will not push in or turn by hand, do not try to repair it. Call a qualified service technician. Force or attempted repair may result in a fire or explosion.

⚠️ WARNING



Danger of explosion. Can cause injury or death. Do not attempt to light manually. Unit has a direct spark ignition system.

This unit is equipped with an automatic spark ignition system. There is no pilot. In case of a safety shutdown, move thermostat switch to **OFF** and return the thermostat switch to **HEAT** to reset ignition control.

A-Placing Unit In Operation

⚠️ WARNING



Danger of explosion and fire. Can cause injury or product or property damage. You must follow these instructions exactly.

Gas Valve Operation (figure 25 and 26)

- 1- Set thermostat to lowest setting.
- 2- Turn off all electrical power to appliance.
- 3- This appliance is equipped with an ignition device which automatically lights the burner. Do **not** try to light the burner by hand.
- 4- Open or remove the control access panel.

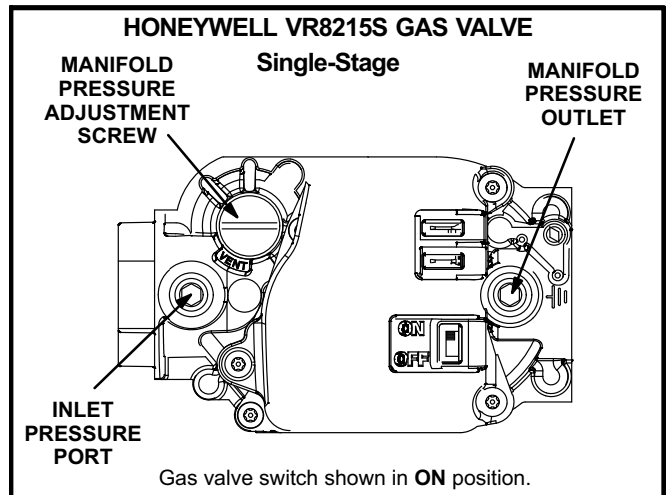

FIGURE 25

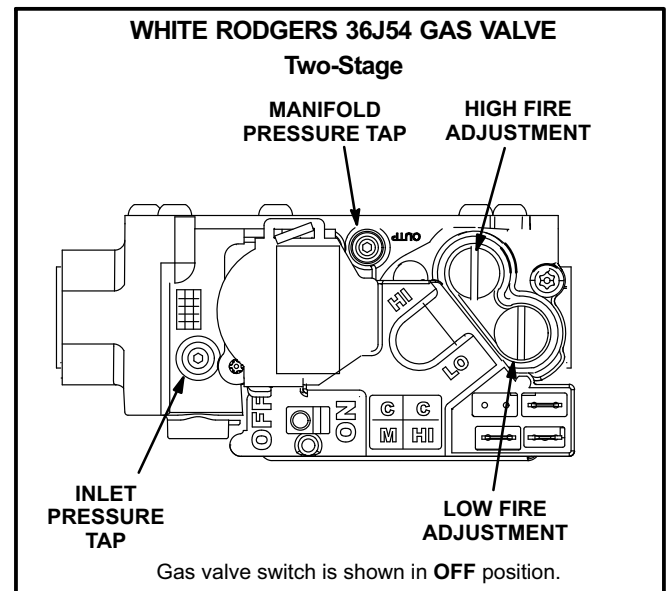

FIGURE 26

- 5- Move gas valve switch to **OFF**. See figure 25 or 26.
- 6- Wait five (5) minutes to clear out any gas. If you then smell gas, **STOP!** Immediately call your gas supplier from a neighbor's phone. Follow the gas supplier's instructions. If you do not smell gas, go to the next step.
- 7- Move gas valve switch to **ON**. See figure 25 or 26.
- 8- Close or replace the control access panel.
- 9- Turn on all electrical power to appliance.
- 10- Set thermostat to desired setting.

NOTE - When unit is initially started, steps 1 through 9 may need to be repeated to purge air from gas line.

- 11- The ignition sequence will start.
- 12- If the furnace does not light the first time (gas line not fully purged), it will attempt up to two more ignitions before locking out.
- 13- If lockout occurs, repeat steps 1 through 10.
- 14- If the appliance will not operate, follow the instructions "Turning Off Gas to Appliance" and call your service technician or gas supplier.

Turning Off Gas to Unit

- 1- If using an electromechanical thermostat, set to the lowest setting.
- 2- Before performing any service, turn off all electrical power to the appliance.
- 3- Open or remove the control access panel.
- 4- Move gas valve switch to **OFF**.
- 5- Close or replace the control access panel.

⚠ WARNING	
	Danger of explosion. Can cause injury or death. Do not attempt to light manually. Unit has a direct spark ignition system.

Heating Operation and Adjustments

(Gas Units)

A-Heating Sequence of Operation

Single- and Two-Stage

- 1- On a heating demand the combustion air inducer starts immediately.
- 2- Combustion air pressure switch proves inducer operation. After a 30-second pre-purge, power is allowed to ignition control. Switch is factory set and requires no adjustment.
- 3- Spark ignitor energizes and gas valve solenoid opens.
- 4- Spark ignites gas, ignition sensor proves the flame and combustion continues.
- 5- If flame is not detected after 8 seconds, the ignition control will repeat steps 3 and 4 two more times. The ignition control will wait 5 minutes before the ignition attempt recycles.

Four-Stage

- 1- On a heating demand, the combustion air inducer starts immediately.
- 2- Combustion air blower (CAB) prove switch allows inducer operation. Power is then supplied to the A3 ignition control, enabling 1st-stage gas heat. The CAB prove switch is factory-set and requires no adjustment.
- 3- After a 30-second pre-purge, the A3 spark ignitor energizes and gas valve 1 (GV1) solenoid opens.
- 4- Spark ignites gas on the first two burners, flame sensor 1 (FS1) proves the flame, and combustion continues. Timing circuits energize 1st-stage, low fire, for approximately 10 minutes.
- 5- If flame is not detected after 8 seconds, the ignition control will repeat steps 3 and 4 two more times. The ignition control will wait 5 minutes before the ignition attempt recycles.
- 6- Before the 10-minute delay applied to 1st stage expires, the timing circuits enable A12 ignition control.
- 7- After a 30-second pre-purge, the A12 spark ignitor energizes and gas valve 3 (GV3) solenoid opens.
- 8- Spark ignites gas on the remaining five burners, flame sensor 2 (FS2) proves the flame, and combustion continues. Timing circuits de-activate 1st-stage after approximately 10 minutes. The remaining 5 burners are energized in 2nd-stage, low fire.

- 9- While a W1 demand is present, 2nd-stage will operate indefinitely.
- 10- Once a W2 demand is applied with 2nd-stage active, power is supplied to the A3 ignition control.
- 11- After a 30-second pre-purge, the A3 spark ignitor energizes and gas valve 1 (GV1) solenoid opens.
- 12- Both 1st- and 2nd -stage active at the same time represents 3rd-stage. Timing circuits enable 3rd-stage, low fire, for approximately 10 minutes.
- 13- At the conclusion of the 10-minute time delay, timing circuits activate the CAB high speed and high fire for both gas valves; 4th-stage is energized.
- 14- If, at any time, the W2 demand is reduced to a W1 demand, the cycle restarts at step 4. Since the first two tubes are already firing, the pre-purge delay and gas ignition are not applicable.

B-Ignition Control Diagnostic LEDs

**TABLE 35
IGNITION CONTROL HEARTBEAT LED STATUS**

LED Flashes	Indicates
Steady Off	No power or control hardware fault.
Steady On	Power applied. Control OK.
3 Flashes	Ignition lockout from too many trials.
4 Flashes	Ignition lockout from too many flame losses within single call for heat.
5 Flashes	Control hardware fault detected.

C-Limit Controls

Limit controls are factory-set and are not adjustable. On single- and two-stage units, the primary limit is located to the right of the combustion air inducer. See figure 36. On four-stage units there are two primary limits; one is located to the right of the combustion air inducer and the other is located to the left of the combustion air inducer.

D-Heating Adjustment

Main burners are factory-set and do not require adjustment.

The following manifold pressures are listed on the gas valve.

- Natural Gas Units - Low Fire - 2.0" w.c.
- Natural Gas Units - High Fire - 3.5" w.c.
- LP Gas Units - Low Fire - 5.9" w.c.
- LP Gas Units - High Fire - 10.5" w.c.

Electric Heat Start-Up (LCH Units)

Optional electric heat will stage on and cycle with thermostat demand. See electric heat wiring diagram on unit for sequence of operation.

Advanced Air Flow Control Start-Up

High efficiency three-, four- and five-ton units equipped with a direct drive blower and optional economizer allows the installer to directly enter the design specified supply air (blower) and outdoor air volume (economizer minimum position) parameters without the need to manually take measurements and adjust settings. The system monitors supply air volume and outside air volume and also has customizable diagnostics.

Note - Unit Controller configuration I.D. 1 character 7 is factory-set to either S or L for the unit to operate in Advanced Air Flow Control mode. When character 7 is set to N or U, the Unit Controller will stage the indoor blower speed but it won't control the damper minimum position.

The economizer is equipped with a PT5 pressure transducer which provides feedback for damper minimum position. See figure 27 for PT5 location. Refer to the economizer installation instructions and Unit Controller manual for additional economizer set-up.

Note - Modulation of dampers for free cooling does not change.

A-Design Specifications

Use table 36 to fill in the field-provided, design-specified supply air CFM and minimum required outdoor/fresh air CFM.

**TABLE 36
FIELD-PROVIDED DESIGN SPECIFICATIONS**

Supply Air CFM	
Heating	CFM
Cooling High	CFM
Cooling Low	CFM
Ventilation	CFM
Economizer Minimum Position	
Outdoor Airflow	CFM

B-Enter Supply Air CFM Into Unit Controller

Use the following menu path to enter each supply air CFM into the Unit Controller. Make sure supply air CFM is within limitations shown in table 37. Refer to the Unit Controller manual provided with unit.

SETTING > RTU OPTIONS > BLOWER > SPEEDS

In the SPEEDS sub-menu, enter CFM values for HEAT, COOLING HIGH, COOLING LOW and VENTILATION. Use the down, up and save push buttons below the display to enter each value.

After the speed CFM are saved, the Unit Controller will cycle to BLOWER CALIBRATION.

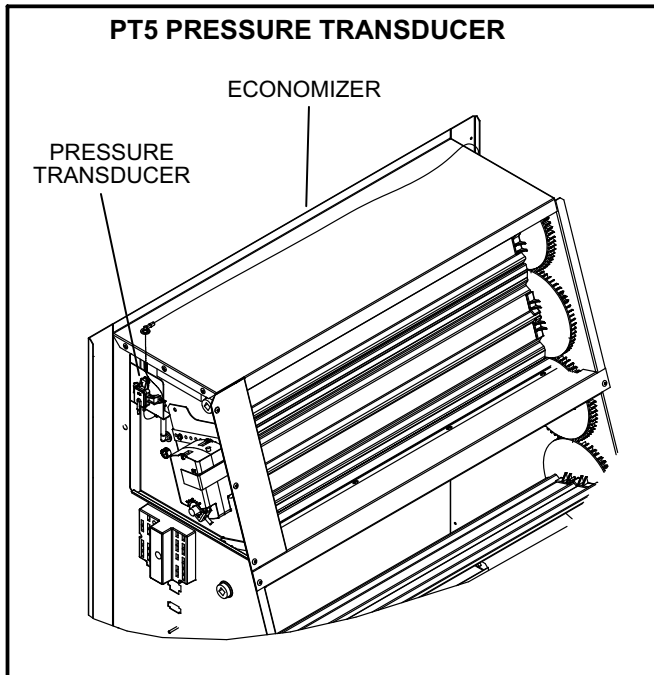

FIGURE 27

CAUTION

The BLOWER CALIBRATION process starts the indoor blower at operational speeds and moves the economizer damper blades. Before starting this process, replace any access panels and close all unit doors except compressor compartment door.

Blower calibration is required only on units that are newly installed or if there is a change in the duct work or air filters after installation. After the new CFM values are entered, use the down and up arrow buttons to select START

CALIBRATION. Push SAVE to start calibration. The blower calibration status is displayed as a % complete. Upon successful completion, the Unit Controller will display CALIBRATION SUCCESS and go back to the blower calibration screen. Press the MAIN MENU button to go to the main menu and press the BACK button to go to the status screen.

If only the CFM values are updated, use the down and up arrow buttons to select "CALIBRATION DONE". Push SAVE to enter the updated values. This selection will not initiate calibration, resulting in less setup time. Press the MAIN MENU button to go to the main menu and press the BACK button to go to the status screen.

C-Enter Outdoor Airflow Design Specifications Into Unit Controller

Use the following menu path to enter the outdoor airflow CFM (replaces minimum damper position set point) into the Unit Controller. Make sure outdoor airflow CFM is within limitations shown in table 37. Refer to the Unit Controller manual provided with unit.

SETTINGS > RTU OPTIONS > DAMPER

Press the SAVE button to cycle through the sub-menu until the OUTDOOR AIRFLOW input screen is displayed. Enter the value and press SAVE.

Press the MAIN MENU button to go to the main menu and press the BACK button to go to the status screen.

D-Operation

1- After calibration, the indoor blower will supply the CFM specified based on the thermostat demand signal received by the Unit Controller:

G – Ventilation CFM

W – Heating CFM

Y1 – Cooling Low CFM

Y2 – Cooling High CFM

2- The Unit Controller, using input from PT5 and the entered outdoor air flow CFM, will open the fresh air dampers to minimum position. In addition, the Unit Controller must have an occupied (OCP) thermostat demand.

**TABLE 37
MINIMUM / MAXIMUM CFM**

LGH/LCH036-060H Unit Parameter Settings			
Parameter Name	LCH/LGH Default Factory Settings		
	036H4E	048H4E	060H4E
SETUP > TEST & BALANCE > BLOWER			
COOLING HI SPEED / HEATING MAXIMUM (480 CFM/TON)	1440	1920	2400
COOLING HI SPEED MINIMUM (280 CFM/TON)	840	1120	1400
COOLING LOW SPEED MINIMUM (220 CFM/TON)	660	880	1100
GAS HEAT - STANDARD - MINIMUM CFM	970	970	970
GAS HEAT - MEDIUM - MINIMUM CFM	1120	1120	1120
GAS HEAT - HIGH - MINIMUM CFM	1310	1310	1310
ELECTRIC HEAT - MINIMUM CFM	1080	1280	1600
VENTILATION MINIMUM (150 CFM/TON)	450	600	750
SETUP > TEST & BALANCE > DAMPER			
OUTDOOR AIRFLOW CFM MAXIMUM CFM	450	600	750
SETTINGS > RTU OPTIONS > EDIT PARAMETER = 12			
In order for the SMOKE CFM change to take effect, go to SETUP > TEST & BALANCE > BLOWER and run the the wizard. Performing this task will recalculate the output to the desired CFM. No adjustments are required during this procedure.			
MSAV SMOKE CFM MAXIMUM	1440	1920	2400

Installer: Configuration ID 1, position 7 needs to be set to either S or L. Circle applicable unit model number and record any CFM changes under "Field Set CFM Value" column. **Settings need to be recorded by installer for use when Unit Controller is replaced or reprogrammed.**

SCR Electric Heat Controller (LCH Units)

Optional factory-installed SCR (A38) will provide small amounts of power to the electric heat elements to efficiently maintain warm duct air temperatures when there is no heating demand. The SCR maintains duct air temperature based on input from a field-provided and installed thermostat (A104) and duct sensor (RT20). SCR is located in the compressor section on the left wall. Use only with a thermostat or specified DDC control system.

Use the instructions provided with the thermostat to set DIP switches as follows: S1 On, S2 Off, S3 Off. Use the instructions provided with the duct sensor to install sensor away from electric element radiant heat and in a location where discharge air is a mixed average temperature.

Once power is supplied to unit, zero SCR as follows:

- 1- Adjust thermostat (A104) to minimum position.
- 2- Use a small screwdriver to slowly turn the ZERO potentiometer on the SCR until the LED turns solid red.
- 3- Very slowly adjust the potentiometer the opposite direction until the LED turns off.

Hot Gas Reheat Start-Up And Operation

General

Hot gas reheat units, available on standard and high efficiency units only, provide a dehumidifying mode of operation. These units contain a reheat coil adjacent to and downstream of the evaporator coil. Reheat coil solenoid valve, L14, routes hot discharge gas from the compressor to the reheat coil. Return air pulled across the evaporator coil is cooled and dehumidified; the reheat coil adds heat to supply air. See figure 28 for reheat refrigerant routing and figure 29 for standard cooling refrigerant routing.

L14 Reheat Coil Solenoid Valve

When Unit Controller input (Unit Controller J298-5 or J299-8) indicates room conditions require dehumidification, L14 reheat valve is energized (Unit Controller P269-3) and refrigerant is routed to the reheat coil.

Reheat Setpoint

Reheat is factory-set to energize when indoor relative humidity rises above 60% (default). The reheat setpoint can be adjusted by changing Unit Controller *Settings - Control* menu. A setting of 100% will operate reheat from an energy management system digital output. The reheat setpoint can also be adjusted using an optional Network Control Panel (NCP).

Reheat will terminate when the indoor relative humidity falls 3% (57% default) or the digital output de-energizes. The reheat deadband can be adjusted at *Settings - Control* menu.

Check-Out

Test reheat operation using the following procedure.

- 1- Make sure reheat is wired as shown in wiring section.
- 2- Make sure unit is in local thermostat mode.
- 3- Use Unit Controller key pad to elect SERVICE > TEST > DEHUMIDIFIER.

The blower and compressor (reheat) should be operating. DEHUMIDIFIER 1 ON will be appear on the Unit Controller display.

- 4- Press BACK on the Unit Controller display to stop the testing mode.

Compressor (reheat) and blower should de-energize.

Default Reheat Operation

During reheat mode free cooling is locked out.

No Y1 demand but a call for dehumidification:

Compressor is operating, blower is on, and the reheat valve is energized.

Y1 demand:

Compressor is operating, blower is on, and the reheat valve is energized.

Y2 demand:

Compressor is operating, blower is on, and the reheat valve is de-energized.

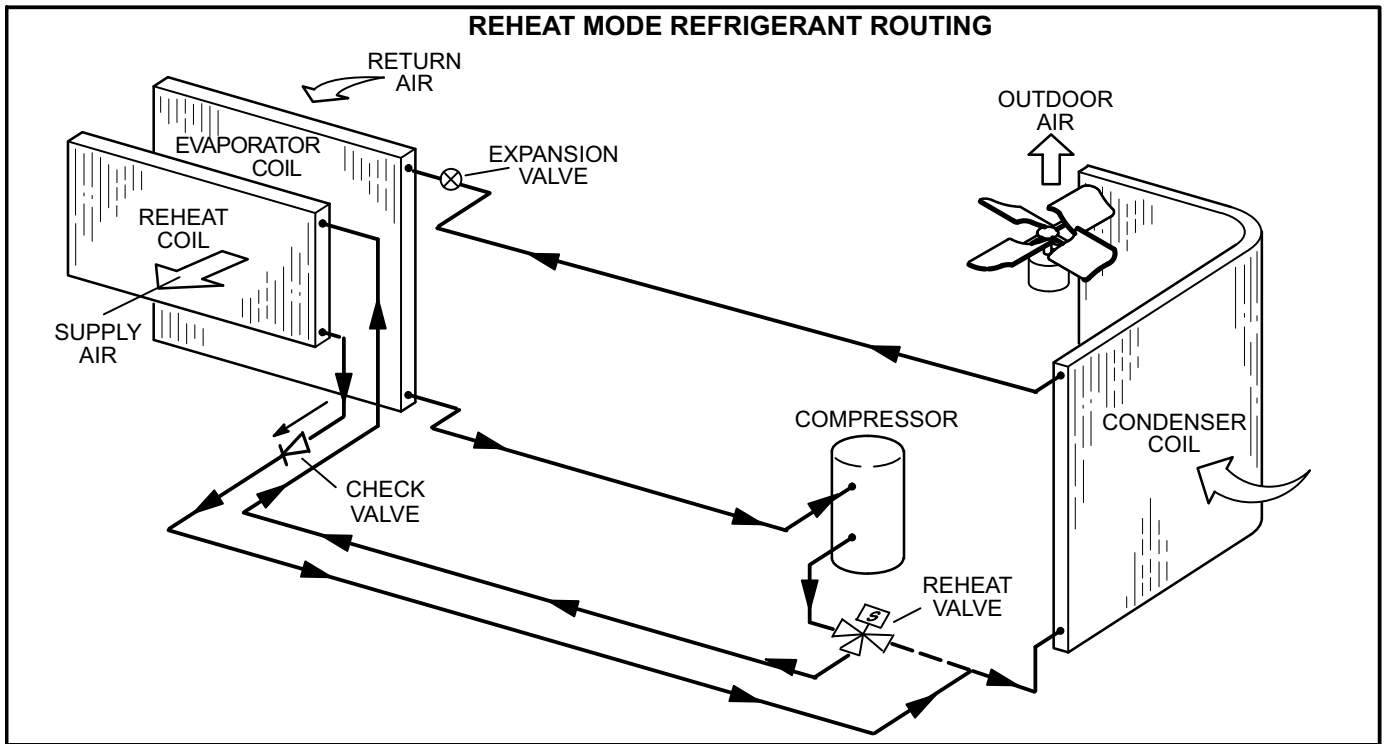

FIGURE 28

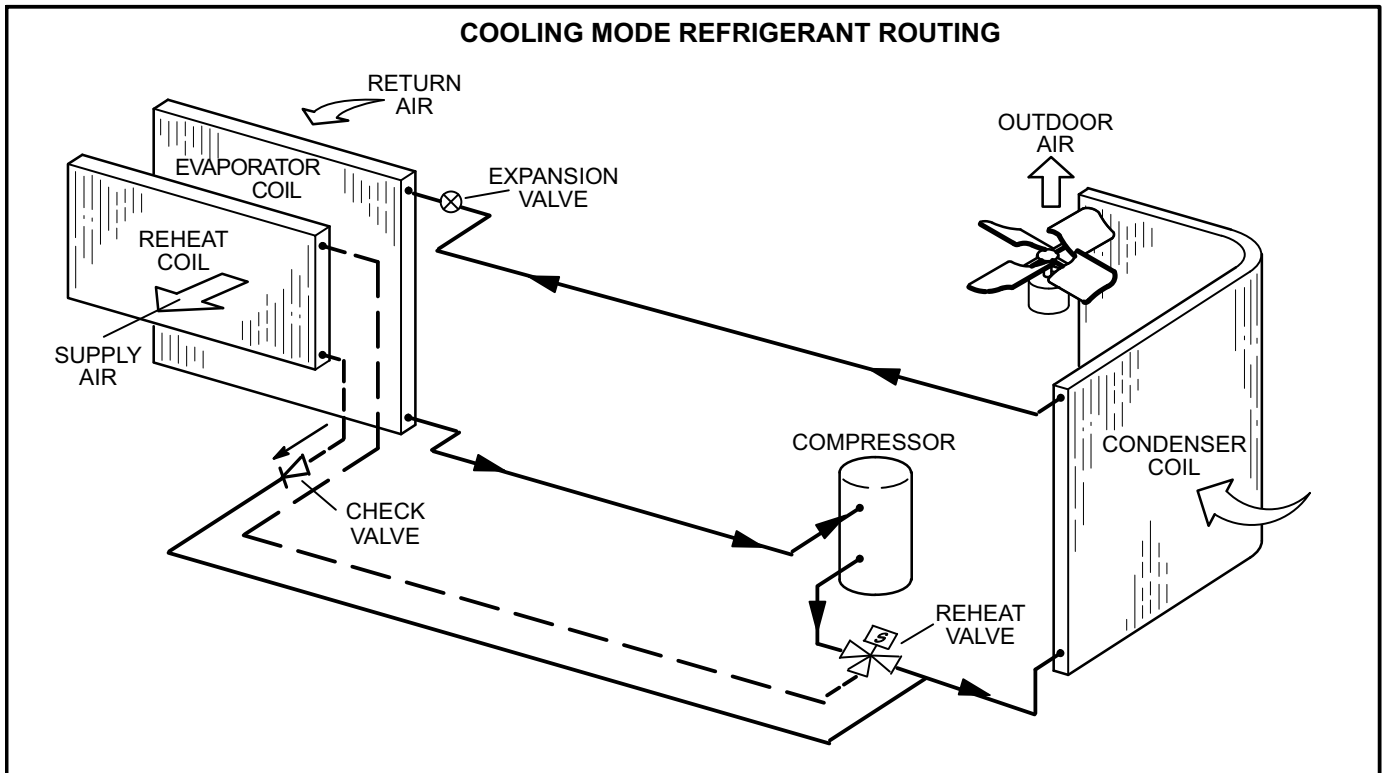

FIGURE 29

Service

The unit should be inspected once a year by a qualified service technician.

⚠ CAUTION

Label all wires prior to disconnection when servicing controls. Wiring errors can cause improper and dangerous operation. Verify proper operation after servicing.

A-Filters

Units are equipped with temporary filters which must be replaced prior to building occupation. See table 38 for correct filter size. Refer to local codes or appropriate jurisdiction for approved filters.

⚠ WARNING

Units are shipped from the factory with temporary filters. Replace filters before building is occupied. Damage to unit could result if filters are not replaced with approved filters. Refer to appropriate codes.

Approved filters should be checked monthly and replaced when necessary. Take note of air flow direction marking on filter frame when reinstalling filters. See figure 30.

**TABLE 38
UNIT FILTERS**

Unit	Qty	Filter Size - inches (mm)
036S, H; 048S, H	4	16 X 20 X 2 (406 X 508 X 51)
036U; 048U; 060S, H, U; 072H, 074U	4	20 X 20 X 2 (508 X 508 X 51)

NOTE-Filters must be U.L.C. certified or equivalent for use in Canada.

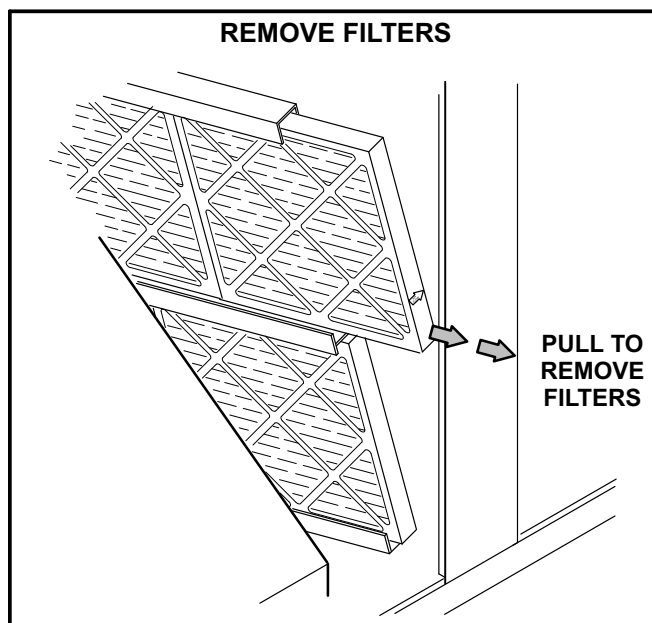

FIGURE 30

B-Lubrication

All motors are lubricated at the factory. No further lubrication is required.

C-Burners (Gas Units)

Periodically examine burner flames for proper appearance during the heating season. Before each heating season examine the burners for any deposits or blockage which may have occurred.

Clean burners as follows:

- 1- Turn off both electrical power and gas supply to unit.
- 2- Remove blower access panel.
- 3- Remove top burner box panel.
- 4- Remove screws securing burners to burner support and lift the individual burners or the entire burner assembly from the orifices. See figure 31 or 32. Clean as necessary.
- 5- Locate the ignitor under the right burner. Check ignitor spark gap with appropriately sized twist drills or feeler gauges. See figure 33.
- 6- Replace burners and screws securing burner. See figure 34 or 35.

⚠ WARNING



Danger of explosion. Can cause injury or death. Do not overtighten main burner mounting screws. Snug tighten only.

- 7- Replace access panel.

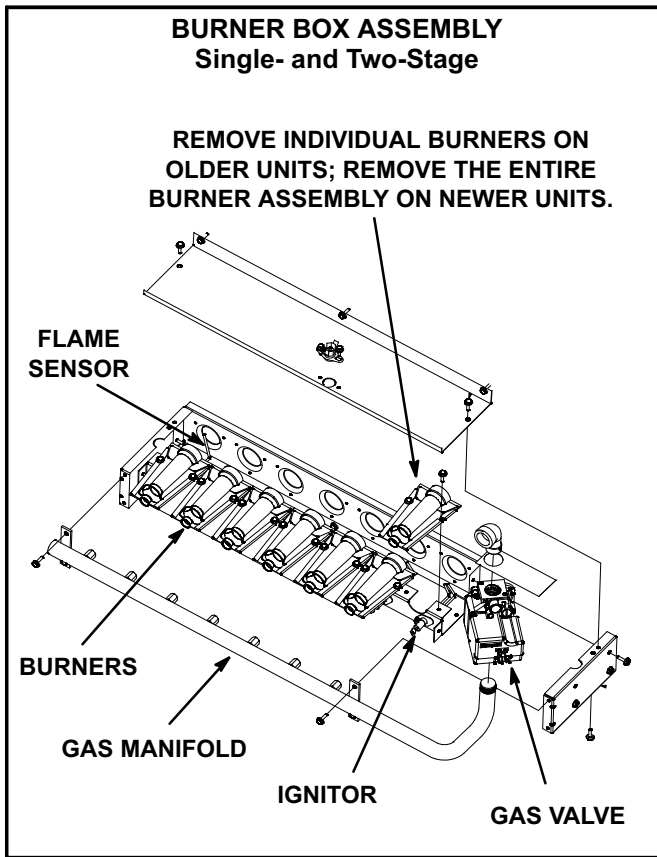

FIGURE 31

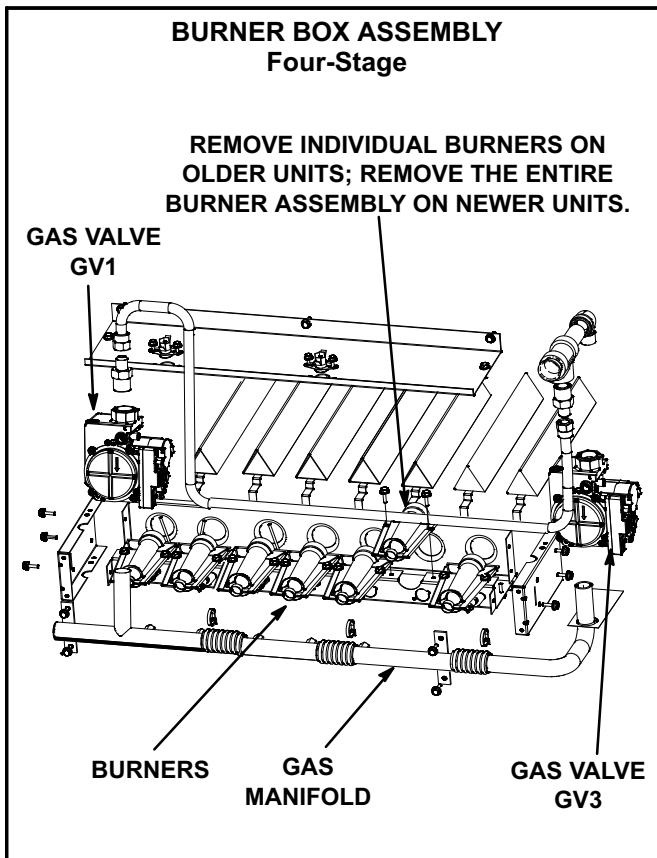

FIGURE 32

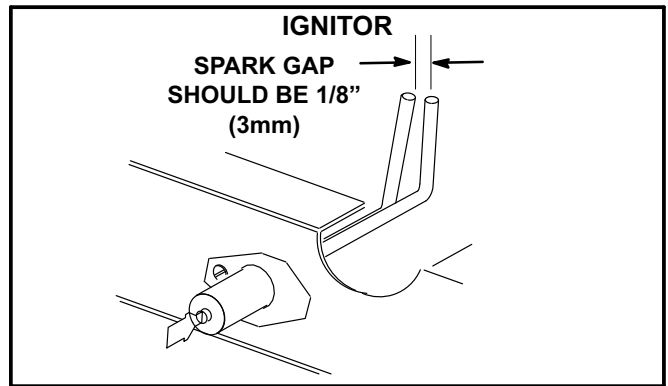

FIGURE 33

8- Restore electrical power and gas supply. Follow lighting instructions attached to unit and use inspection port in access panel to check flame.

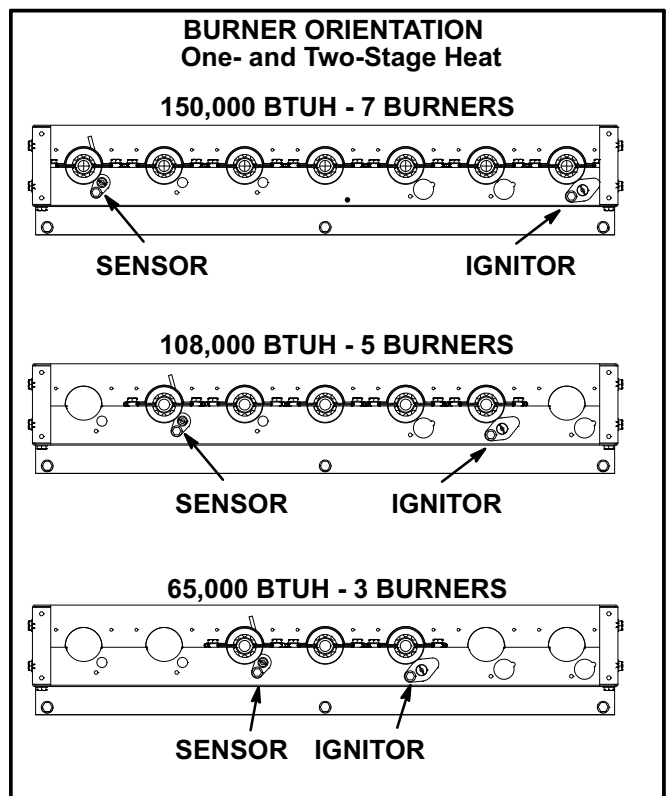

FIGURE 34

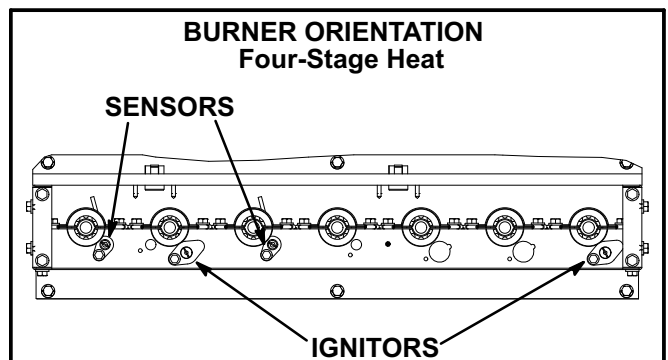

FIGURE 35

D-Combustion Air Inducer (Gas Units)

A combustion air proving switch checks combustion air inducer operation before allowing power to the gas controller. Gas controller will not operate if inducer is obstructed.

Under normal operating conditions, the combustion air inducer wheel should be checked and cleaned prior to the heating season. However, it should be examined periodically during the heating season to establish an ideal cleaning schedule.

Clean combustion air inducer as follows:

- 1- Shut off power supply and gas to unit.
- 2- Remove the mullion on the right side of the heat section.
- 3- Disconnect pressure switch air tubing from combustion air inducer port.
- 4- Remove and retain screws securing combustion air inducer to flue box. Remove vent connector. See figure 36.
- 5- Clean inducer wheel blades with a small brush and wipe off any dust from housing. Take care not to damage exposed fan blades. Clean accumulated dust from front of flue box cover.
- 6- Return combustion air inducer motor and vent connector to original location and secure with retained screws. It is recommended that gaskets be replaced during reassembly.

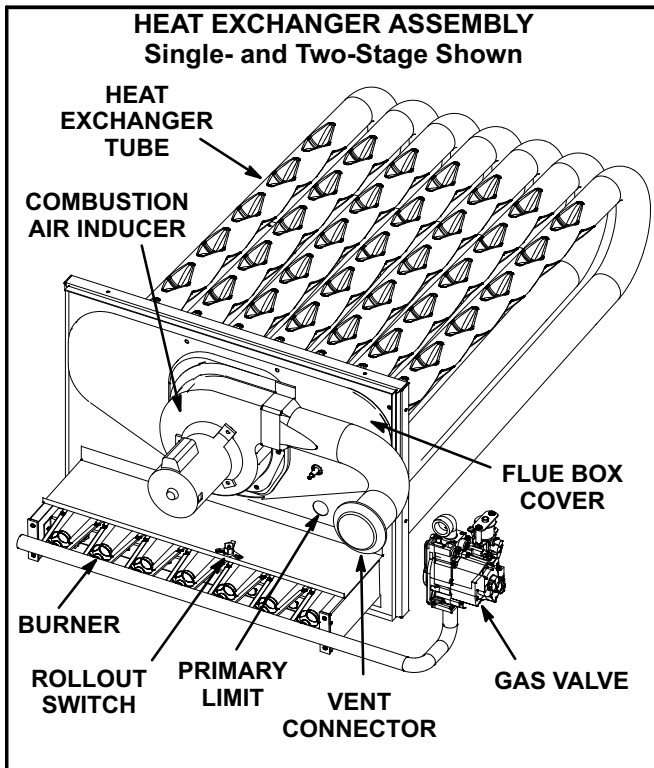

FIGURE 36

7- Replace mullion.

8- Clean combustion air inlet louvers on blower access panel using a small brush.

E-Flue Box (Gas Units)

Remove flue box cover only when necessary for equipment repair. Clean inside of flue box cover and heat exchanger tubes with a wire brush when flue box cover has to be removed. Install a new flue box cover gasket and replace cover. Make sure edges around flue box cover are tightly sealed.

F-Evaporator Coil

Inspect and clean coil at beginning of each cooling season. Clean using mild detergent or commercial coil cleaner. Flush coil and condensate drain with water taking care not to get insulation, filters and return air ducts wet.

G-Condenser Coil

All-Aluminum Coils -

Clean condenser coil annually with water and inspect monthly during the cooling season.

Clean the all-aluminum coil by spraying the coil steadily and uniformly from top to bottom. Do not exceed 900 psi or a 45° angle; nozzle must be at least 12 inches from the coil face. Take care not to fracture the braze between the fins and refrigerant tubes. Reduce pressure and work cautiously to prevent damage.

Fin/Tube Coils -

Clean condenser coil annually with detergent or commercial coil cleaner and inspect monthly during the cooling season.

Condenser coils are made of single and two formed slabs. On units with two slabs, dirt and debris may become trapped between the slabs. To clean between slabs, carefully separate coil slabs and wash them thoroughly. See figure 37. Flush coils with water following cleaning.

Note - Remove all screws and gaskets prior to cleaning procedure and replace upon completion.

H-Supply Air Blower Wheel

Annually inspect supply air blower wheel for accumulated dirt or dust. Turn off power before attempting to remove access panel or to clean blower wheel.

CLEAN CONDENSER COIL - UNITS WITH FIN/TUBE COILS

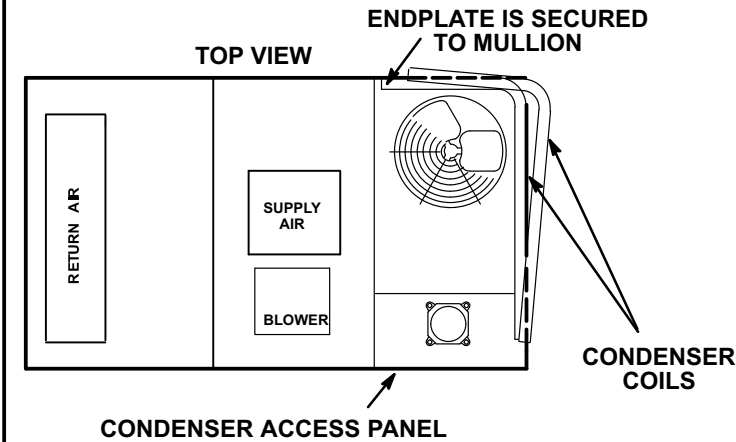

- 1- Remove unit top panel and condenser section access panel.
- 2- Remove screws securing coil end plate to mullion.
- 3- Remove wire ties connecting coils slabs and separate slabs 3-4" (76-102mm).
- 4- Clean coils with detergent or commercial coil cleaner.
- 5- Rinse thoroughly with water and reassemble. Use field-provided wire ties to connect coil slabs.

FIGURE 37

Factory Unit Controller Settings

Use the Unit Controller to adjust parameters; menu paths are shown in each table. Refer to the Unit Controller manual provided with each unit.

Tables 39 through 42 show factory settings (in degrees, % of fan CFM, etc.). Record adjusted settings on the label located inside the compressor access panel.

When field installing optional kits and accessories, the Unit Controller must be configured to identify the option before it will function. Refer to figures 38 and 39 to determine whether the Unit Controller configuration I.D. must change. To configure the option, use MAIN MENU > SETUP > INSTALL menu path. Press SAVE until CONFIGURATION ID 1 or 2 appears depending on the option installed. Change the appropriate character in the configuration I.D. For example, when an economizer is installed using a single enthalpy sensor, change configuration I.D. 1, the second character, to "S".

**TABLE 39
580730**

Units With BACnet Module Settings	
Use menu SETUP > NETWORK INTEGRATION. Set "BACNET" and network address.	
BACNET MAC ADDRESS:	

**TABLE 40
580732**

Units With Room Sensor, CPC/LSE Gateway Settings	
Use menu SETUP > NETWORK INTEGRATION. Set "L CONNECTION" and network address.	
LCONN ADDRESS:	

**TABLE 41
580734**

Units With Hot Gas Reheat			
Use SETTINGS > RTU OPTIONS > EDIT PARAMETERS			
Parameter	Factory Setting	Field Setting	Description
105	6		Hot Gas Reheat Option 6: Reheat is only possible if blower is energized during occupied periods. Controlled by RH sensor (A91) connected to input A55_P298_5 and set point set at parameter 106 (default 60%).
414	10 sec (-036, -048, -060 All-Aluminum Coils only)		HI CL REHEAT TMOUT: Number of seconds Reheat Valve remains energized upon thermostat call for high stage cooling (default 0 seconds).

**TABLE 42
580735**

Units with BACnet Module (Target) Settings			
Use menu SETUP > NETWORK INTEGRATION. Set "BACNET" and network address.			
BACNET MAC ADDRESS:			
Parameter	Factory Setting	Setting	Description
Use SETTINGS > RTU OPTIONS > EDIT PARAMETERS			
91	120		Sets the compressor minimum run time to 2 minutes.
106	99		Set reheat SP from connected sensor to 99% to basically disable. Reheat will be controlled over by BAS. Only applies to units with the reheat option.
111	3		Thermostat with three cooling stages.
117	0		DCV max. open damper. 0=controlled by network.
153	60		Time delay between heating and cooling mode.

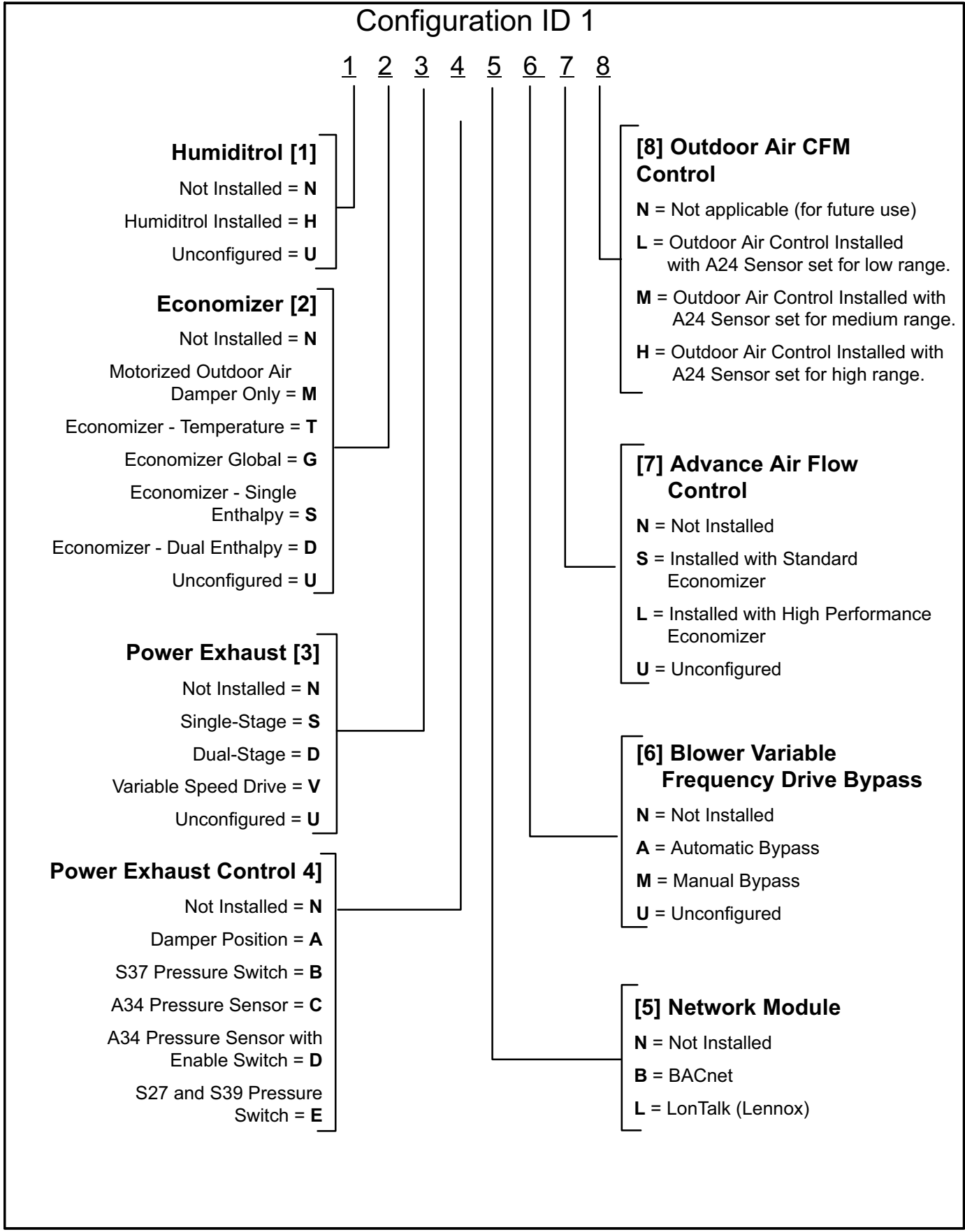

FIGURE 38

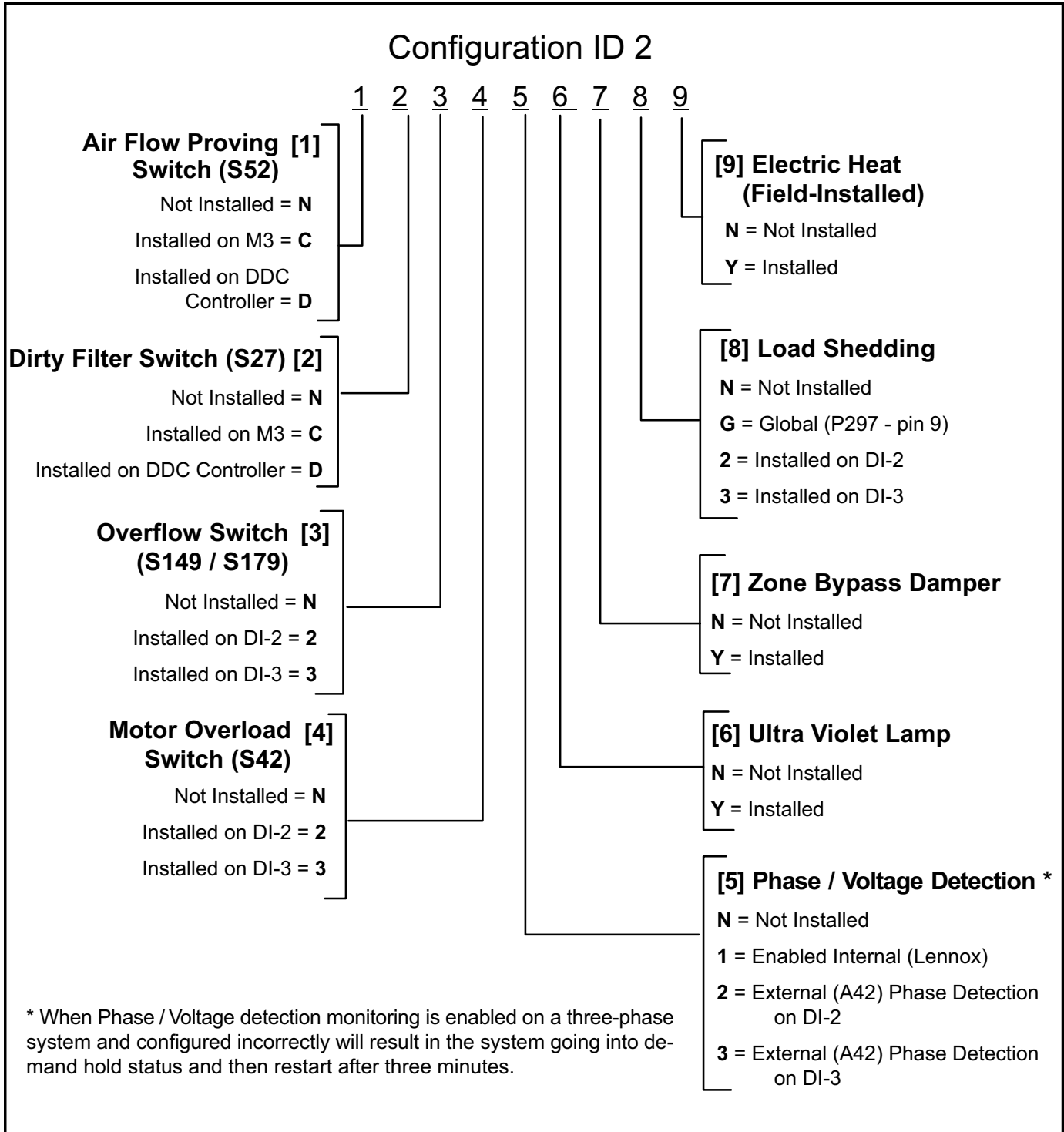

FIGURE 39