

## Technical Bulletin

# LEAD FREE\*

## LFF113RFP

### Flood Protection Shut Down Valve

- Installed upstream of Reduced Pressure Zone Backflow Preventer.
- Normally Open Valve - Closes when continuous discharge from RPZ Relief Valve is sensed or by engaging Solenoid By-Pass.
- Valve must be manually reset. Pressure gauge (provided) indicates valve reset for automatic service.
- Position Indicator provides local visual indication of valve closure.
- Reverse Flow Main Valve closes in the event of diaphragm failure for fail-safe operation
- Specially coated Valve Stem for added protection.
- Heavy duty Cover Spring.
- JB113 provided Valve mounted. FS99 field installed.

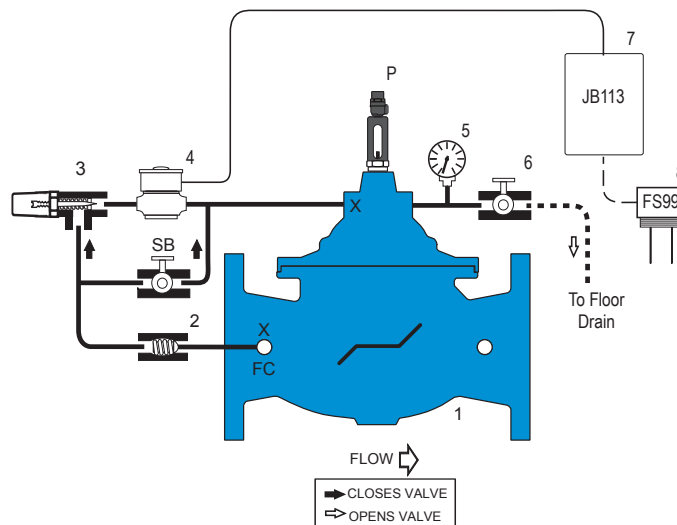

#### Standard Components

- 1 - Main Valve (Single Chamber)
- 2 - Check Valve
- 3 - Adjustable Closing Speed
- 4 - 2-Way Solenoid
- 5 - Pressure Gauge
- 6 - Manual Reset Ball Valve
- 7 - JB113 Junction Box
- 8 - FS99 Flow Sensor
- P - Position Indicator
- SB - Solenoid By-Pass
- X - Isolation Cocks
- FC - Flow Clean Strainer

#### Options and Accessories

- -LS (Single NEMA 4 Limit Switch)
- -LS2 (Dual NEMA 4 Limit Switch)

#### Materials

Body & Cover:	Ductile Iron ASTM A536
Coating:	NSF Listed Fusion Bonded Epoxy Lined and Coated
Trim:	316 Stainless Steel
Elastomers:	Buna-N (standard) EPDM Viton
Stem, Nut & Spring	Stainless Steel

#### NOTICE

The information contained herein is not intended to replace the full product installation and safety information available or the experience of a trained product installer. You are required to thoroughly read all installation instructions and product safety information before beginning the installation of this product.

**\*The wetted surface of this product contacted by consumable water contains less than 0.25% of lead by weight.**

Viton® is a registered trademark of DuPont Dow Elastomers.

Watts product specifications in U.S. customary units and metric are approximate and are provided for reference only. For precise measurements, please contact Watts Technical Service. Watts reserves the right to change or modify product design, construction, specifications, or materials without prior notice and without incurring any obligation to make such changes and modifications on Watts products previously or subsequently sold.

## Typical Installation

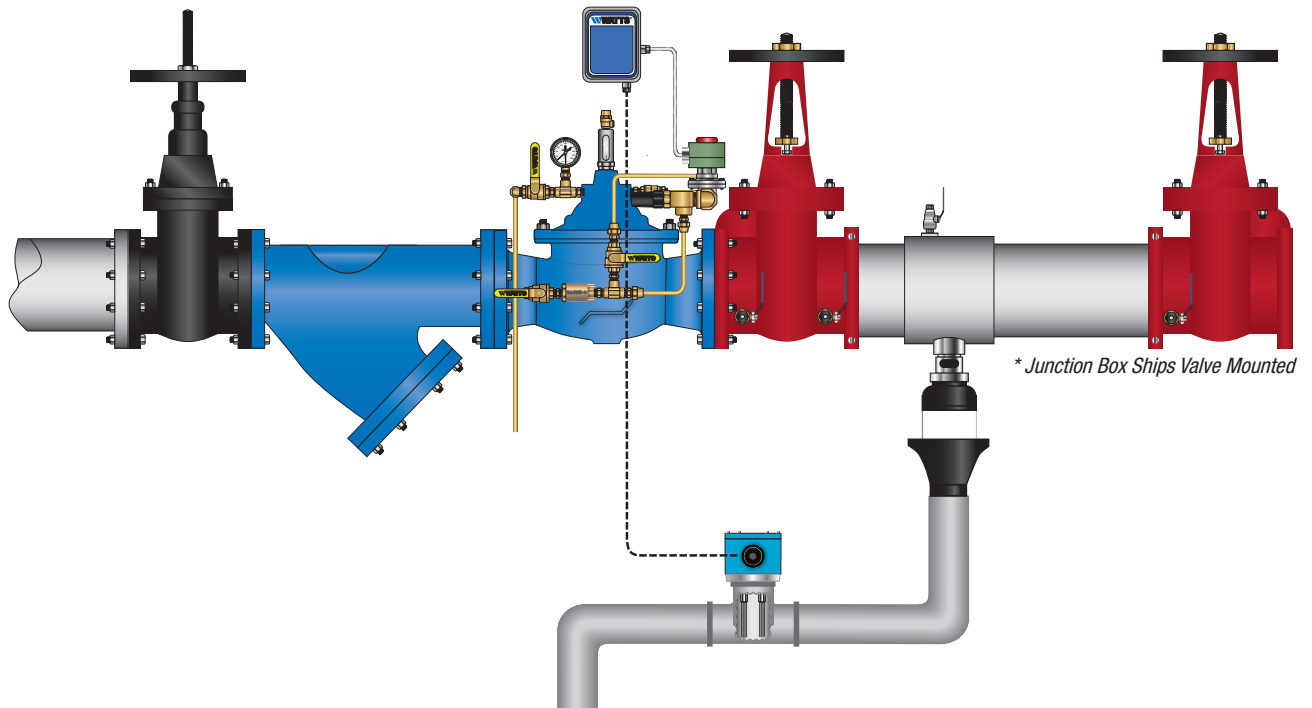

## Operation

The Watts Flood Protection Shutdown Valve system prevents catastrophic property damage that can occur due to Relief Valve discharge and/or a blocked or overwhelmed floor drain during normal relief valve operation. Typical conditions which can cause continuous relief valve discharge are:

- Fouled First Check Seat due to dirt, debris or rocks
- Failed First Check Spring
- Clogged or blocked Relief Valve Sensing Line
- Relief Valve Diaphragm failure

The Watts LFF113RFP Flood Protection Shutdown Valve is a normally open valve designed to be installed upstream of a Reduced Pressure Zone (RPZ) Backflow Prevention device. It is normally open and closes when continuous relief valve discharge through the drain pipe

is sensed by the FS99 Flow Sensor, energizing the Solenoid Pilot. The valve is equipped with a Solenoid By-Pass valve (normally closed) which manually closes the Main Valve when engaged. The valve mounted JB113 Junction Box is equipped with an adjustable time delay to avoid valve closure due to intermittent or nuisance relief valve discharge. The Position Indicator provides local, visual indication of valve closure and is useful during valve start-up and troubleshooting. The valve remains closed and cannot re-open if flow stops or electrical service is interrupted, and must be manually reset after the RPZ is diagnosed and/or repaired.

The valve comes complete with the valve mounted JB113 Junction Box with adjustable time delay, pre-wired Solenoid Valve, Manual Reset with Pressure Gauge, Position Indicator and FS99 Flow Sensor (field installed).

### NOTICE

If the LFF113RFP unit is installed in any orientation other than horizontal (Cover Up) or extreme space constraints exist, consult customer service prior to ordering.

# Technical Bulletin - LFF113RFP

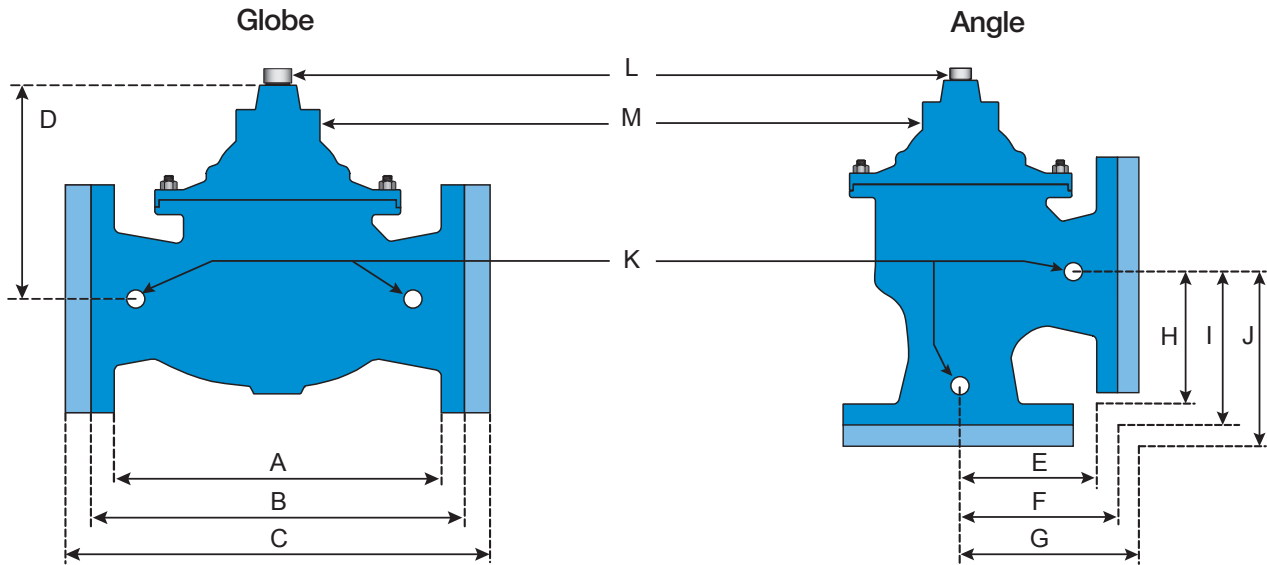

Operating Pressure	
Threaded =	400 psi
150 Flanged =	250 psi
300 Flanged =	400 psi

Operating Temperature	
Buna-N:	160°F Maximum
EPDM:	300°F Maximum
Viton:	250°F Maximum

Pilot System	
Solenoid	
Brass (NEMA 4 General Purpose 110-VAC)	

Tubing & Fittings	
Copper / Brass (Standard)	
Stainless Steel (Optional)	

## Dimensions

Valve Size	Globe Thread		Globe 150#		Globe 300#		Cover To Center		Angle Thread		Angle 150#		Angle 300#		Angle Thread		Angle 150#		Angle 300#		Port Size NPT	Port Size NPT	Port Size NPT	Shipping Weights*	
	A	B	C	D	E	F	G	H	I	J	K	L	M												
in.	in.	mm	in.	mm	in.	mm	in.	mm	in.	mm	in.	mm	in.	mm	in.	mm	in.	mm	in.	mm	in.	in.	in.	lbs.	kgs.
1¼	7¼	184					3½	89	3¼	83					1⅞	48					¼	½	⅛	15	7
1½	7¼	184	8½	216			3½	89	3¼	83	4	102			1⅞	48	4	102			¼	½	⅛	15	7
2	9¾	238	9¾	238	10	254	4⅞	125	4	102	4	102	4¼	108	4	102	4	102	4¼	108	½	½	¼	35	16
2½	11	279	11	279			7	178	5½	140	5½	140	5⅜	148	4	102	4	102	4⅞	110	½	½	⅜	65	30
3	10½	267	12	305	13¼	337	7	178	5¼	133	5¾	146	6⅞	156	5¼	133	5¾	146	6⅞	156	½	½	⅜	95	43
4			15	381	15¾	397	8¾	219			6¾	171	7⅞	181			6¾	171	7⅞	181	½	½	⅜	190	86
6			20	508	21	533	11¾	298			8½	216	8⅞	225			8½	216	8⅞	225	½	½	½	320	145
8			25¾	645	26¾	670	15¾	400			11	279	11½	292			11	279	11½	292	½	1	½	650	295

## Valve Cover Chamber Capacity

Valve Size - Inches	1¼	1½	2	2½	3	4	6	8
fl.oz.	4	4	4	10	10	22	70	
U.S. Gal								1¼

## Valve Travel

Valve Size - Inches	1¼	1½	2	2½	3	4	6	8
Travel - Inches	¾	¾	½	¾	¾	1	1½	2

# Technical Bulletin - LFF113RFP

## Flow Data - ACV F100 (Globe) / F1100 (Angle)

Valve Size - Inches		1¼	1½	2	2½	3	4	6	8
Suggested	Maximum Continuous Flow Rate Gpm (Water)	93	125	208	300	460	800	1800	3100
	Maximum Intermittent Flow Rate Gpm (Water)	115	158	260	370	570	1000	2300	3900
	Minimum Flow Rate Gpm (Water)	3	5	6	9	15	16	17	25
C <sub>v</sub>	Factor GPM (Globe)	29	34	55	75	125	220	460	775
	Factor GPM (Angle)	39	53	66	99	170	280	650	1100

- Maximum continuous flow based on velocity of 20 ft. per second.
- Maximum intermittent flow based on velocity of 25 ft. per second.
- Minimum flow rates based on a 20-40 psi pressure drop.
- The C<sub>v</sub> Factor of a valve is the flow rate in US GPM at 60°F that will cause a 1psi drop in pressure.
- C<sub>v</sub> factor can be used in the following equations to determine Flow (Q) and Pressure Drop (ΔP):

$$Q \text{ (Flow)} = C_v \sqrt{\Delta P} \quad \Delta P \text{ (Pressure Drop)} = (Q/C_v)^2$$

- The C factors stated are based upon a fully open valve.
- Many factors should be considered in sizing control valves including inlet pressure, outlet pressure and flow rates.
- For sizing questions including cavitation analysis consult Watts with system details.

### Headloss

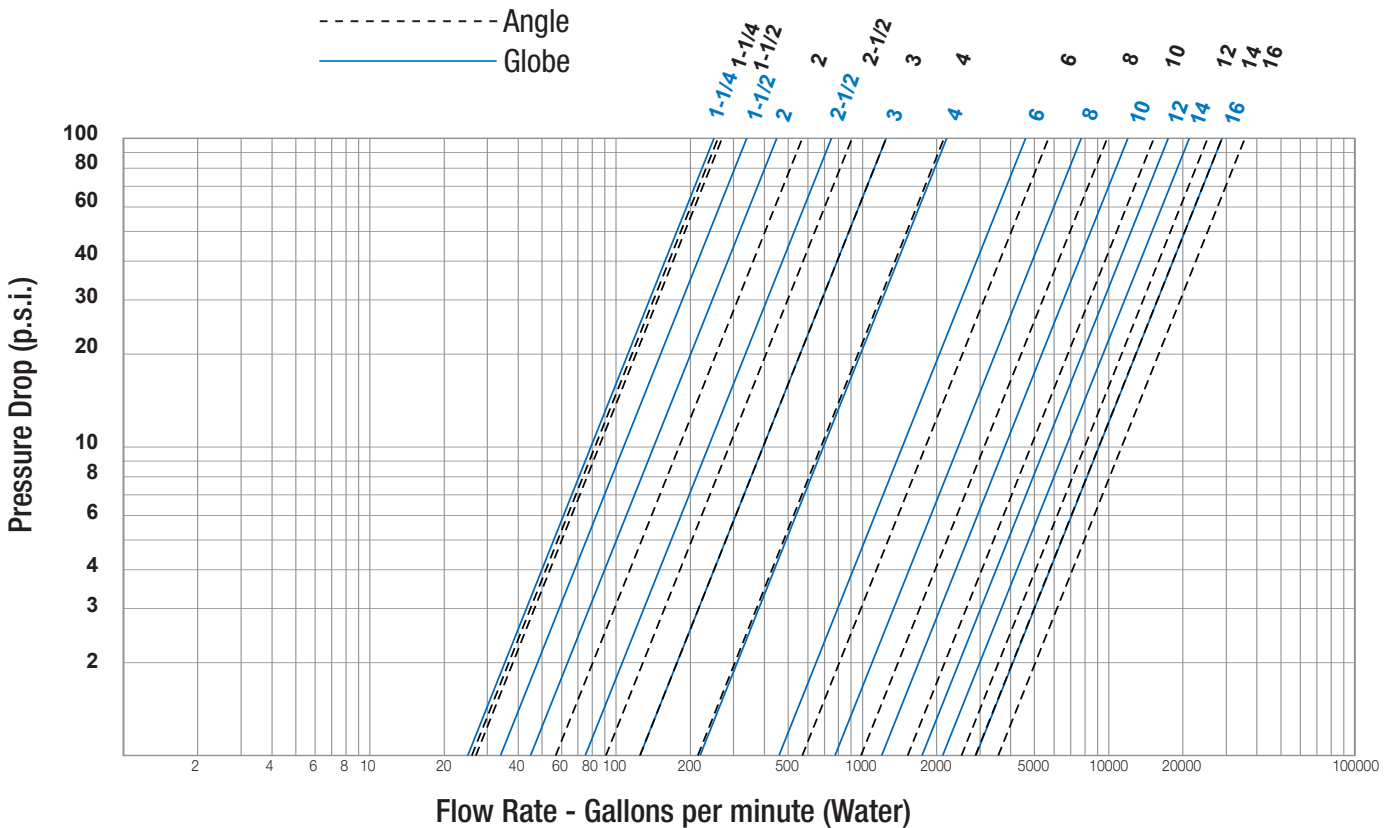

The C<sub>v</sub> Factor of a valve is the flow rate in US GPM at 60° F that will cause a 1 psi drop in pressure. The factors stated are based upon a fully open valve.

C<sub>v</sub> factor can be used in the following equations to determine Flow (Q) and Pressure Drop (Δ P):

$$Q \text{ (Flow)} = C_v \sqrt{\Delta P} \quad \Delta P \text{ (Pressure Drop)} = (Q/C_v)^2$$

# Technical Bulletin - LFF113RFP

## F100 Main Valve

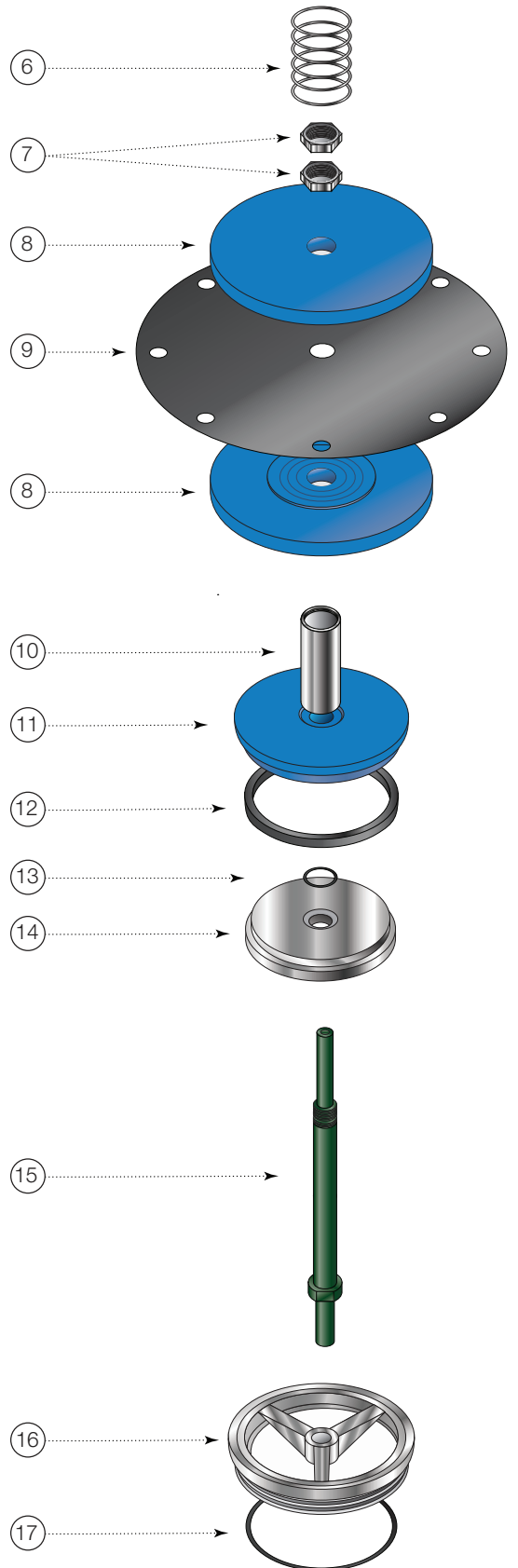
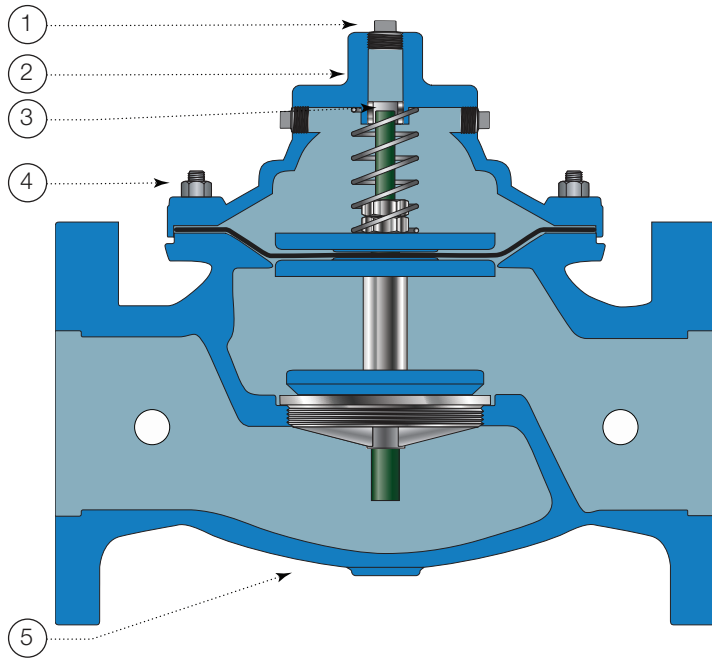

Item	Description	Material
1	Pipe Plug	Lead Free Brass
2	Cover	ASTM A536 65-45-12 Epoxy Coated Ductile Iron
3	Cover Bearing	ASTM A276 304 Stainless Steel
4	Stud with Cover Nut and Washer	ASTM A570 Gr.33 Zinc Plated Steel
5	Body	ASTM A536 65-45-12 Epoxy Coated Ductile Iron
6	Spring	ASTM A276 302 Stainless Steel
7	Stem Nut	ASTM A276 304 Stainless Steel
8	Diaphragm Washer	ASTM A536 65-45-12 Epoxy Coated Ductile Iron
9	Diaphragm*	Buna-N (Nitrile)
10	Spacer	ASTM A276 304 Stainless Steel
11	Quad Seal Retainer	ASTM A536 65-45-12 Epoxy Coated Ductile Iron
12	Quad Seal*	Buna-N (Nitrile)
13	O-Ring*	Buna-N (Nitrile)
14	Quad Seal Plate	ASTM A743 CF8M (316) Stainless Steel
15	Shaft / Stem	ASTM A276 304 Stainless Steel - Xylan Coated
16	Seat Ring	ASTM A743 CF8M (316) Stainless Steel
17	Seat Gasket*	Buna-N (Nitrile)

\* Contained in Main Valve Repair Kit

## Junction Box

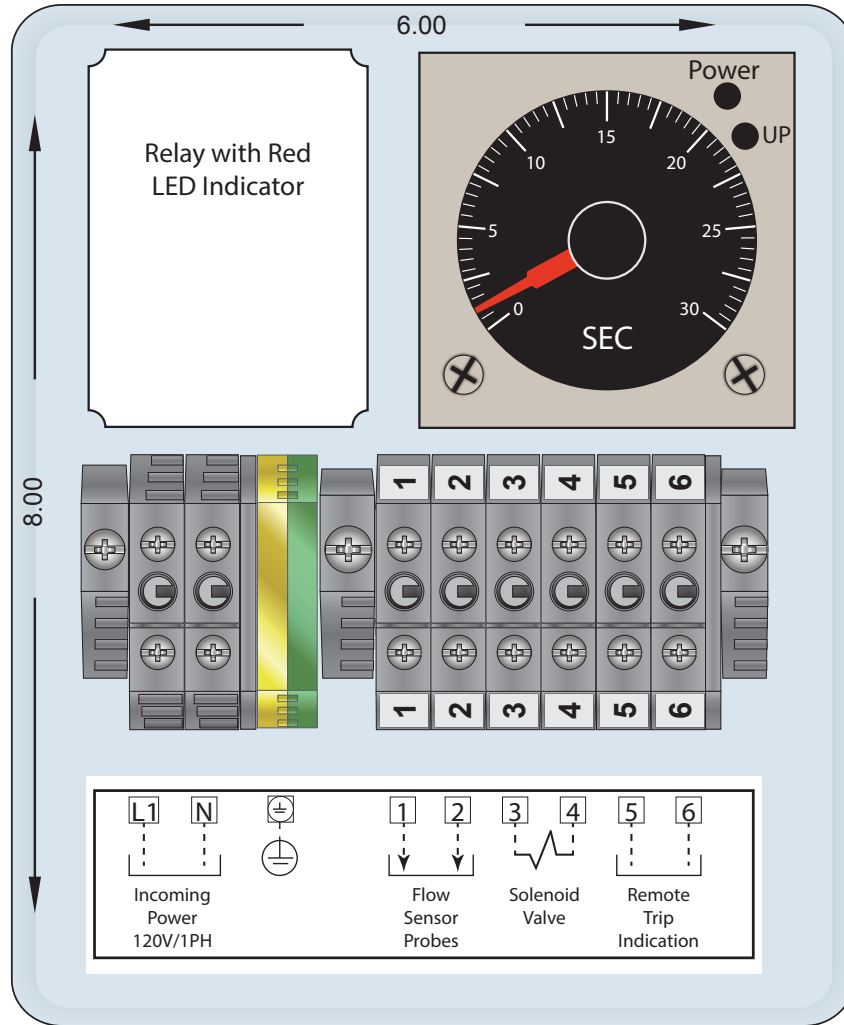

**CERTIFIED ELECTRICIAN TO CONNECT MAIN POWER AND FS99 FLOW SENSOR TO JB113 JUNCTION BOX**

The valve mounted JB113 Junction Box is a lockable NEMA 4 enclosure equipped with an adjustable time delay, electrical relay and terminal strip. There are three 3/4 inch conduit connections. The valve solenoid is prewired.

The valve is normally open and closes when continuous relief valve discharge through the drain pipe is sensed by the FS99 Flow Sensor.

The valve mounted JB113 Junction Box is equipped with an adjustable time delay to avoid valve closure due to intermittent or nuisance relief valve discharge. The time delay is adjustable from 0-30 seconds.

Adjusting the dial clockwise increases the time delay for valve closure. Adjusting the dial counterclockwise decreases the time delay for valve closure.

### Terminals 1 & 2:

Connect to FS99 Flow Sensor Probes.

### Terminals 3 & 4:

Prewired to the solenoid.

### Terminals 5 & 6:

Terminals 5 and 6 may be used for remote trip indication to an alarm or Building Management System.

### Installation Notes:

- Terminal block accepts 10-22 AWG
- Remote indication terminals 5 & 6 have a 120V, 10AMP maximum.
- Required voltage for JB114 Junction Box is 120V.
- Probe Voltage is 12VAC 1.5mA.
- Less than 1 amp draw.

## Accessories



### Model 50 - Position Indicator

The Model 50 Position Indicator is installed in the topmost cover port of the Main Valve and allows for visual indication of valve position. The Model 50 is also very useful during valve start-up and troubleshooting procedures.

A stainless steel indicating rod threads into the tapped portion of the Main Valve stem and moves inside of a cylindrical Pyrex sight tube. The indicating rod travels up and down, following Main Valve stem movement. The housing protects the sight tube and indicating rod, and allows visibility on two sides. The screw driver operated test cock installed on the top of the Model 50 housing provides a controlled method of removal of air from the cover chamber during start-up or troubleshooting of the Main Valve.

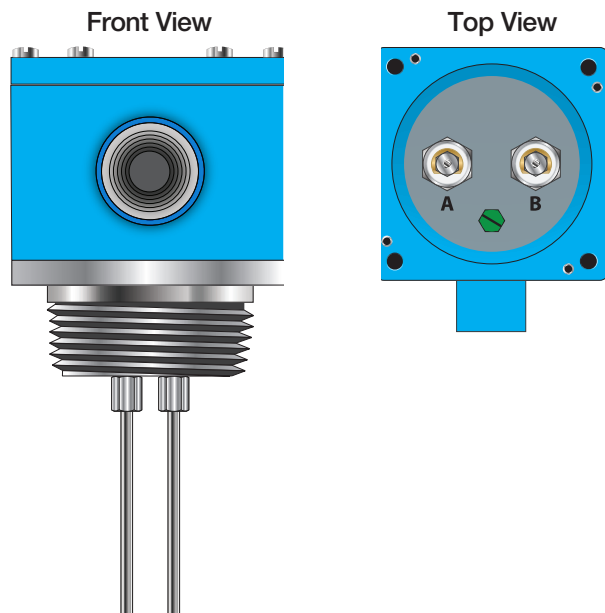

### FS99 - Flow Sensor

The FS99 Flow Sensor is field installed in the discharge piping from the RPZ Relief Valve. The FS99 senses water in the discharge piping signaling the JB113 Junction Box to close the valve.

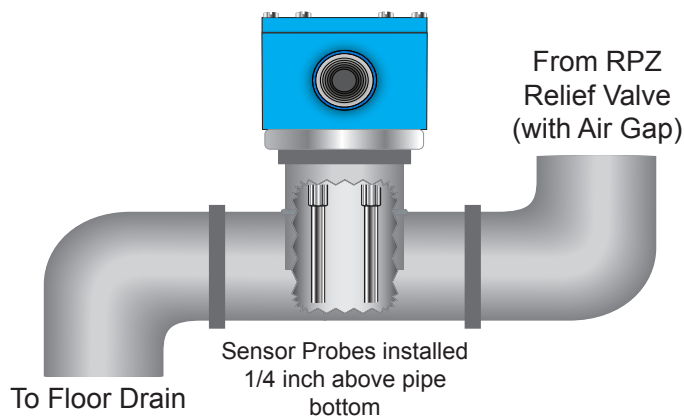

### NOTE TO INSTALLING CONTRACTOR

- Client/Contractor to provide installation Tee for Flow Sensor.
- Install Flow Sensor in RPZ discharge line in HORIZONTAL position as shown.
- Sensor Probes should be cut to length and installed 1/4 inch above pipe bottom.
- ENSURE SENSOR PROBES DO NOT CONTACT PIPE BOTTOM OR SIDES.
- CERTIFIED ELECTRICIAN TO CONNECT MAIN POWER AND FS99 FLOW SENSOR TO JB113 JUNCTION BOX

## Accessories

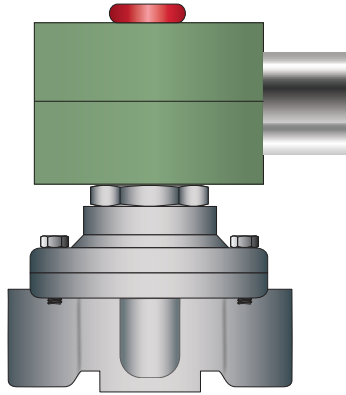

The Solenoid is prewired to the JB113 Junction Box and is equipped with a Solenoid By-Pass valve (normally closed) which manually closes the Main Valve when engaged.

Opening the Solenoid By-Pass Valve (SB) pressurizes the Main Valve cover as indicated by Pressure Gauge (5), closing the Main Valve.

Closing Solenoid By-Pass Valve and opening the Manual Reset Ball Valve (6) returns the Main Valve to the full open position. Pressure Gauge returns to zero when the Main Valve is fully open.

Note: Manual Reset Ball Valve must be closed for normal operation.

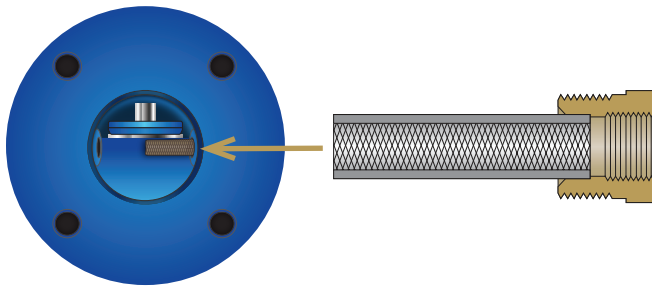

Valve Inlet

The valve pilot circuit is equipped with a Model 60 Flo-Clean Strainer which is used to filter the fluid passing through the control pilot circuit, and provide protection to pilot circuit speed controls and pilots. It is installed in the inlet body port of the main valve, exposing the strainer element to main line flow. The currents and flow across the screen create a self-scouring effect, cleaning the filter element.

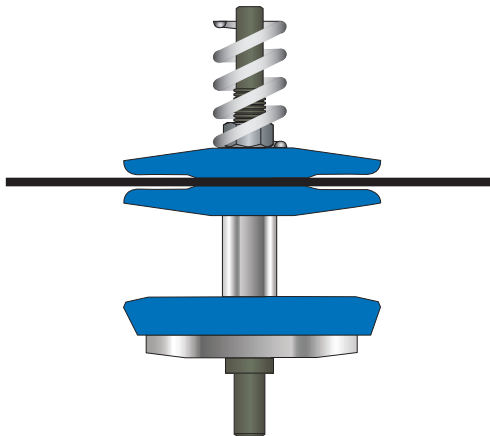

The Main Valve is provided standard with a specially coated Main Valve Stem for stand-by service. The special coating helps deter the effects of hard water and mineral deposits which may prohibit proper valve operation.

The Main Valve is also provided standard with a heavy cover spring to provide additional operating differential.



## Start-Up

Proper Automatic Control Valve start-up requires bringing the valve into service in a controlled manner. All adjustments to control pilots and speed controls should be made slowly, allowing the valve to respond and the system to stabilize. **NOTE: Control Valves should be set-up in a dynamic (flowing) condition for proper start-up. Provisions for flow must be made to insure proper settings.**

1. Refer to valve schematic. Close Solenoid By-Pass Valve (SB). Locate and open Manual Reset Ball Valve (6). Open upstream and downstream isolation valves to allow controlled filling of the Valve and Backflow Assembly. Open all Isolation Ball Valves.
2. Inlet pressure will open the valve fully. Close Manual Reset Ball Valve.
3. Open Solenoid By-Pass Valve to simulate electrical shutdown signal. Inlet pressure will be indicated on Pressure Gauge (5) and valve will begin to close. Due to low / no flow condition, valve closure may be slower than normal operation.
4. Close Solenoid By-Pass Valve and open Manual Reset Ball Valve. Pilot System Pressure Gauge will drop to zero. Valve will open fully and is ready for electrical activation. Allow for cover volume to discharge to floor drain. Refer to chart on Page 2 for Cover Chamber Volume. Close Manual Reset Ball Valve.
5. Open JB113 Junction Box. Apply power and observe the Electric Relay Control.
6. Pour adequate amount of water into RPZ Relief Valve Air Gap until the RED LED indicator light on the Electrical Relay illuminates / flashes. This indicates the FS99 Flow Sensor is properly installed and is sensing water in the discharge piping.
7. Trap water in discharge piping and observe RED LED on Electrical Relay. Solenoid will energize when duration of Time Delay elapses. Valve will go closed and must be manually reset. Adjust Time Delay to Customer / Project specifications. To manually reset valve refer to Step 4.
8. For final test simulate actual RPZ Relief Valve discharge and observe floor drain for excessive pooling or flooding. Re-adjust time delay and Adjustable Closing Speed (3) control as needed to achieve desired valve closure time.

## Technical Bulletin - LFF113RFP

### Specifications

The Flood Protection Shutdown Valve shall be a normally open Diaphragm Valve installed upstream of the Reduced Pressure Zone Backflow Assembly, and automatically close if the RPZ relief valve begins to discharge. A Time Delay supplied in the JB113 Junction Box shall prevent the valve from closing on intermittent discharges from the RPZ relief valve. If continuous Relief Valve discharge occurs, the FS99 Flow Sensor installed horizontally in the RPZ Relief Valve discharge piping shall send a signal to the JB113 Junction Box energizing Solenoid to close the main valve. Once closed the Flood Protection Shutdown Valve must be manually reset.

The JB113 Junction Box shall be valve mounted with the Solenoid pre-wired. The FS99 Flow Sensor shall be provided with the valve package and shall be field installed in a horizontal position in the RPZ Relief Valve discharge piping. Vertical installation of the Flow Sensor shall not be acceptable. The valve shall be equipped with a Position Indicator to provide local visual indication of valve closure. The Position Indicator shall be a stainless steel indicating rod which follows main valve stem movement as seen through a cylindrical Pyrex sight tube.

The Reduced Pressure Zone Backflow Assembly, Flood Protection Shutdown Valve, JB113 Junction Box and FS99 Flow Sensor shall be provided by the same manufacturer and be covered by a single warranty policy.

The main valve shall be a hydraulically operated, single diaphragm actuated, globe or angle pattern valve. Y-pattern valves shall not be permitted. The valve shall contain a disc and diaphragm assembly that forms a sealed chamber below the valve cover, separating operating pressure from line pressure. The diaphragm shall be constructed of nylon reinforced Buna-N, and shall not seal directly against the valve seat and shall be fully supported by the valve body and cover. Rolling diaphragm construction will not be allowed and there shall be no pistons operating the main valve or any pilot controls.

The main valve body and cover shall be Ductile Iron ASTM A536, and all internal cast components shall be Ductile Iron or CF8M (316) Stainless Steel. All Ductile Iron components, including the body and cover, shall be lined and coated with an NSF 61 Certified Epoxy Coating applied by the electrostatic heat fusion process. All main valve throttling components (valve seat and disc guide) shall be Stainless Steel. The valve body and cover must be machined with a 360-degree locating lip to assure proper alignment.

The disc and diaphragm assembly shall contain a Buna-N synthetic rubber disc with a rectangular cross-section that is securely retained on 3-1/2 sides by a disc retainer and disc guide. Diaphragm assemblies utilizing bolts or cap screws for component retention will not be permitted. Direction of flow through the valve shall be the under-the-disc design.

The exposed portion of the seat disc shall contact the valve seat and seal drip-tight. The disc and diaphragm assembly must be guided by two separate bearings, one installed in the valve cover and one concentrically located within the valve seat, to avoid deflection and assure positive disc-to-seat contact. Center guided valves will not be permitted. The main valve spring shall be the manufacturer's heavy or extra heavy spring design. All necessary repairs shall be made from the top of the valve while the body remains in line.

The Pilot Control System shall contain a Flo-Clean Strainer, NEMA 4, 120 VAC 60HZ 2-Way Solenoid with Manual Operator, Manual Reset Ball Valve, Pressure Gauge, Visual Position Indicator, JB113 Junction Box and Isolation Ball Valves on all body connections. The JB113 Junction Box shall be valve mounted and the FS99 Flow Sensor shall be field installed.

The valve shall be Watts Model LFF113RFP (globe) or LFF1113RFP (angle) Flood Protection Shutdown Valve.

# Series 009, 909, 919, 957 and 994

## Reduced Pressure Zone Assemblies

### Relief Valve Discharge Rates

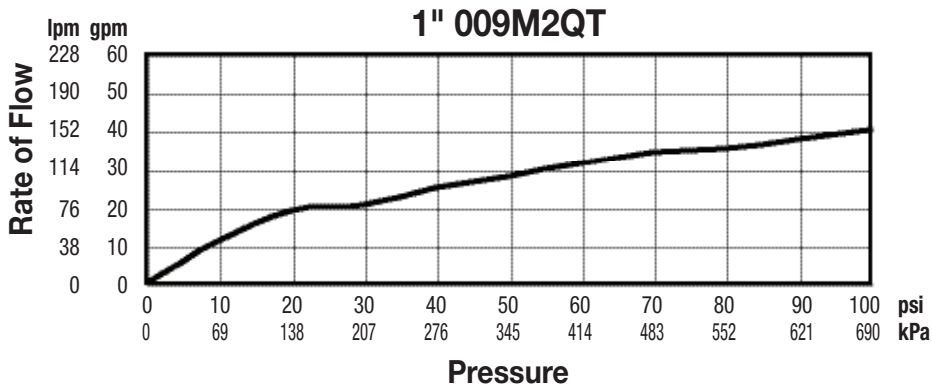
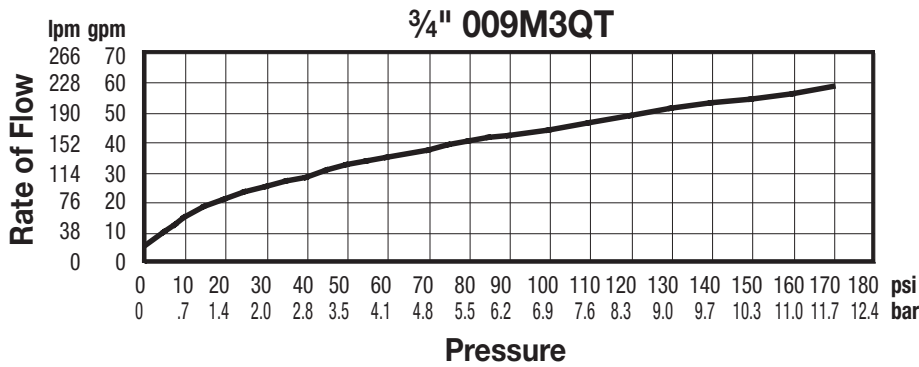
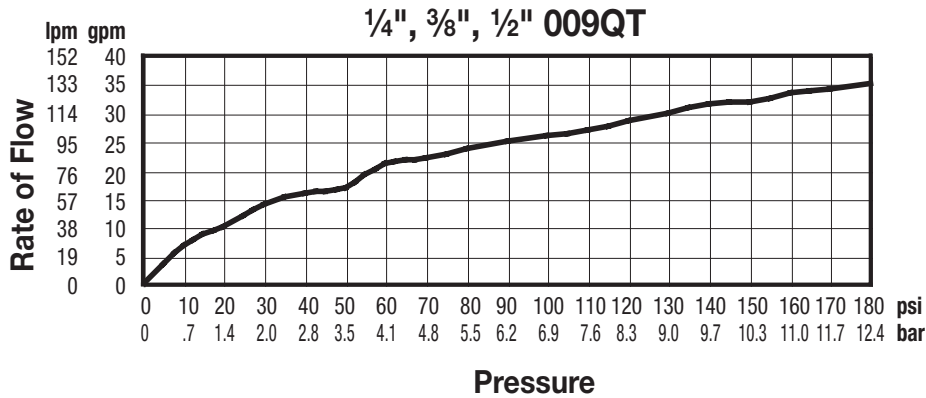

**Note:** These curves represent catastrophic or worst case discharge rates. These curves were developed by pressurizing the outlet of the backflow preventer with the second check valve's internals removed from the body.

# Technical Bulletin - LFF113RFP

## 1 1/4" 009M2QT

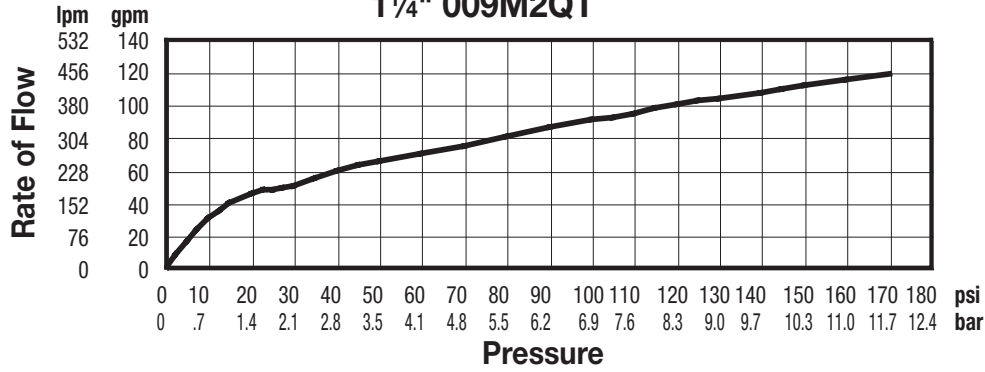

## 1 1/2" 009M2QT

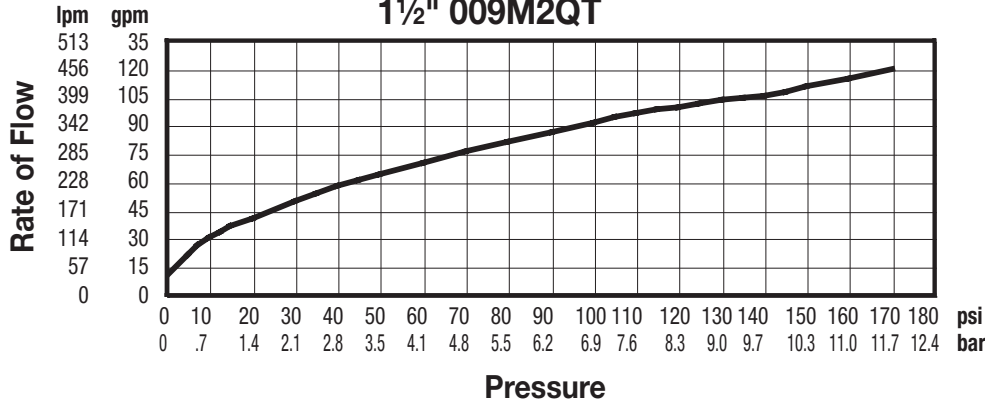

## 2" 009M2QT

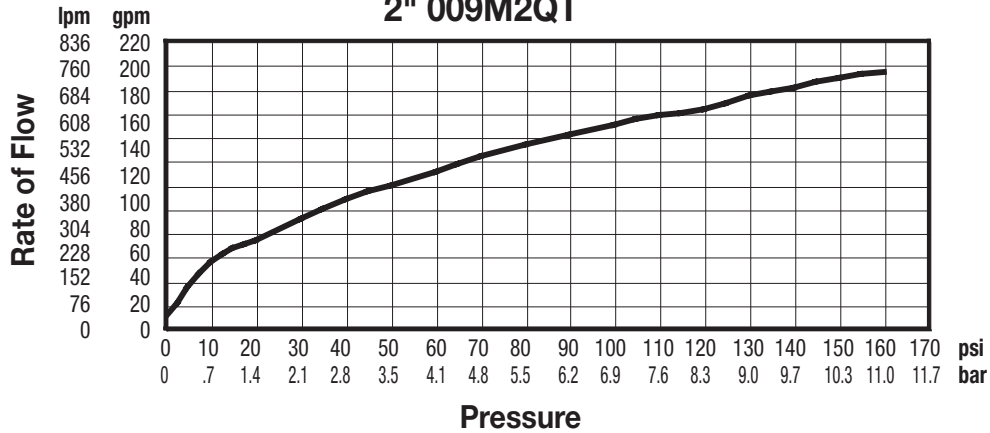

## 2 1/2", 3" 009

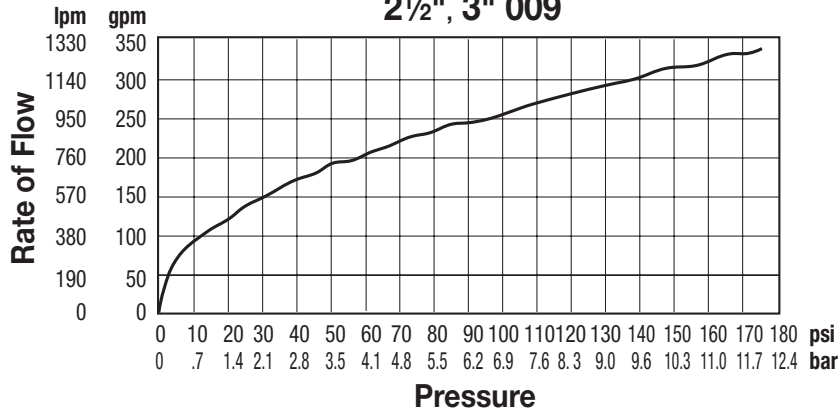

**Note:** These curves represent catastrophic or worst case discharge rates. These curves were developed by pressurizing the outlet of the backflow preventer with the second check valve's internals removed from the body.

# Technical Bulletin - LFF113RFP

### 3/4", 1" 909

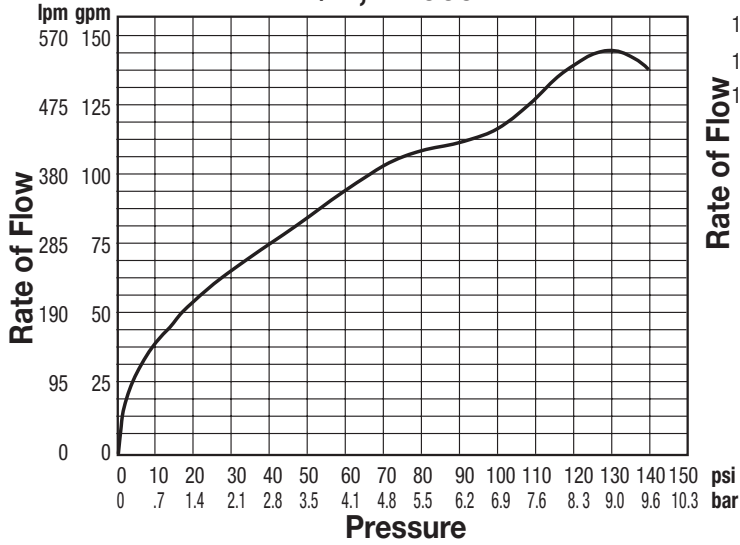

### 1 1/4", 1 1/2", 2" 909

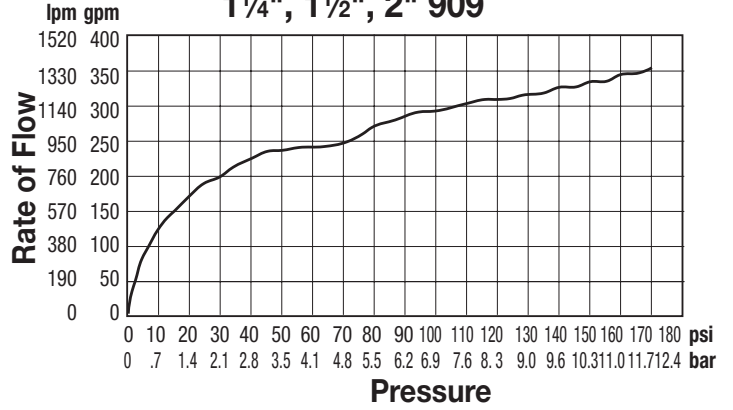

### 2 1/2" - 3" 909

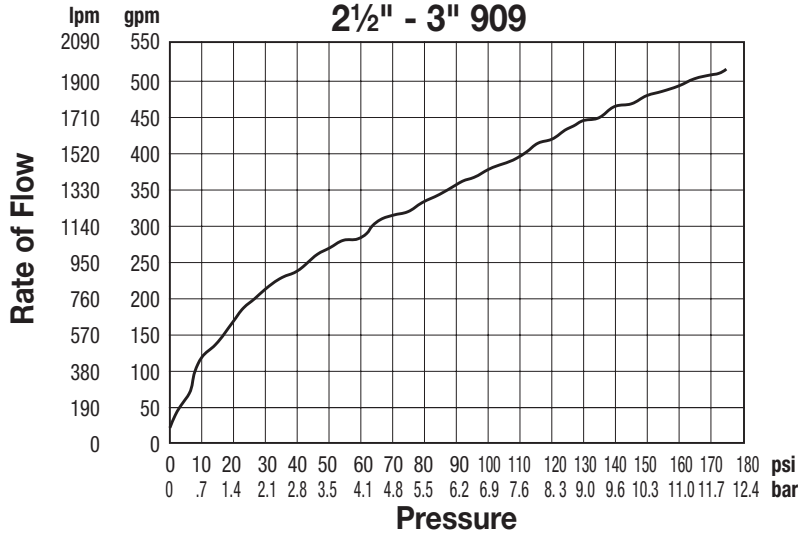

### 4", 6", 8", 10" 909

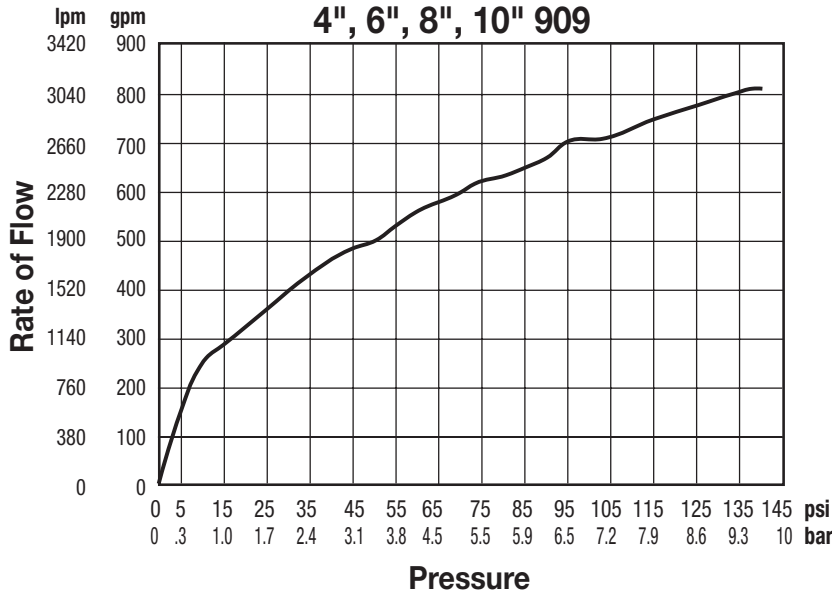

**Note:** These curves represent catastrophic or worst case discharge rates. These curves were developed by pressurizing the outlet of the backflow preventer with the second check valve's internals removed from the body.

# Technical Bulletin - LFF113RFP

**1" 919 RV**  
Capacity w/Second Check Removed

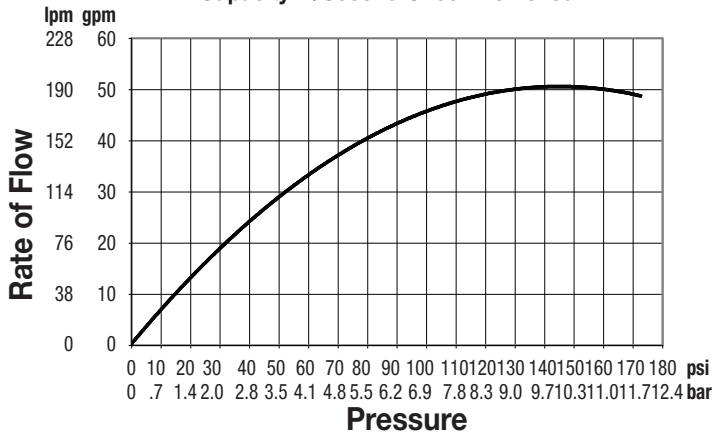

**2" 919 QT**  
Backpressure w/Second Check Poppet & Spring Removed

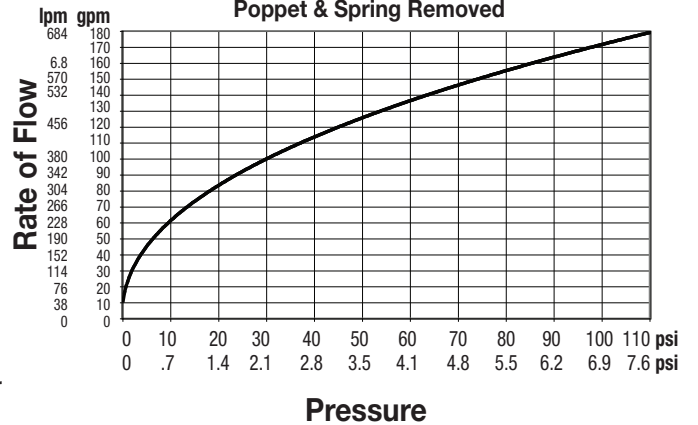

**2½" - 10" 994**

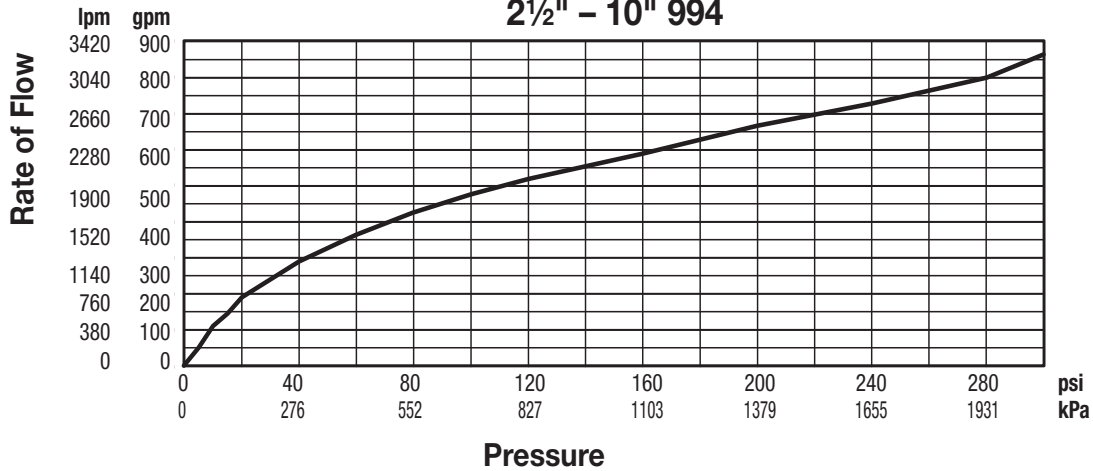

**2½" - 10" 957**

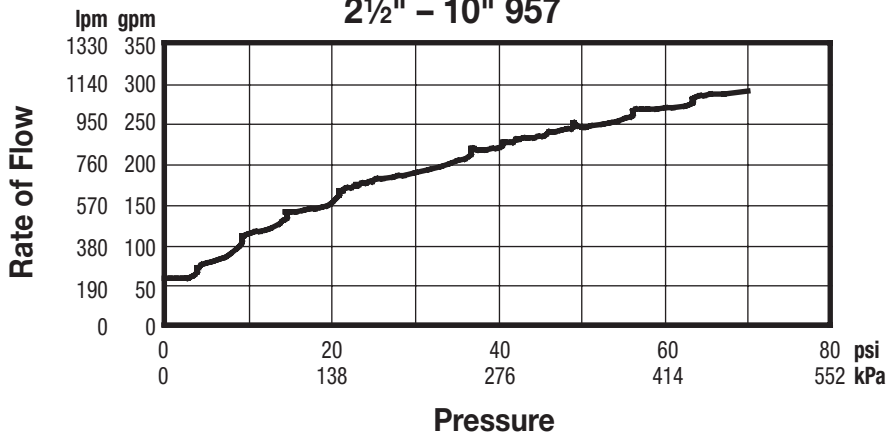

**Note:** These curves represent catastrophic or worst case discharge rates. These curves were developed by pressurizing the outlet of the backflow preventer with the second check valve's internals removed from the body.

Typical Flow Rates as sized by floor drain manufacturers		Drain Size
gpm	lpm	
55	209	2
112	426	3
170	646	4
350	1330	5

