



8403-060 Temperature and Humidity Controller with Ventilation Output

Introduction

The Bard 8403-060 Controller offers temperature, humidity, and ventilation control with easy setup. A large backlit display screen shows setpoints, indoor temperature, humidity, and user defined settings. A simple 5 button interface offers simple navigation and selection of features. Easy to navigate setup menus allow for the controller to be configured and the unit operational in a matter of minutes. The 8403-060 controller is a great economical solution for light commercial or school applications where ventilation and scheduling is required.



8403-060

Controller Features

Standard Features

- Easy to use 5 button control.
- Programmable scheduling.
- Retains settings.
- Easy to use interface.
- Ventilation control.
- Interchange between °C/°F
- Emergency Heat
- Humidity Control.
- Configurable Scheduler.
- Password Protection.
- easy to read backlit display.
- Smart recovery mode for energy savings.

Options and accessories

- Outdoor sensor 8403-061.
- Indoor sensor 8403-062.

Integration

- This controller is recommended for local control only. The 8403-060 does not use BACnet or Modbus remote communication for building management systems.

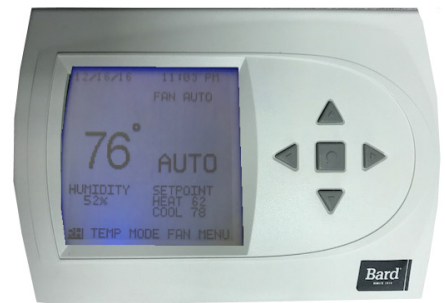

Backlit Display



8403-061



8403-062

Controller Summary

Feature	Description
Staging	3 Heating/3 Cooling Stages. Operates 1 or 2 stage compressor products.
Changeover Heat/Cool	Auto or Manual.
Fan Operation	Auto, On, or Programmed (on during occupied, off during unoccupied).
Operating Temperature Range	32°F to 104°F (0°C to 40°C).
Storage Temperature Range	-40°F to 135°F (-40°C to 57°C).
Heating and Cooling Setpoint Range	50°F to 99°F (10°C to 37°C). Max. Heating and Min. Cooling is adjustable.
Humidity Control Setpoint Range	45%RH to 95%RH.
Dehumidification Operation (Requires Unit with Dehumidification Option)	Occupied schedule or full time operation based on humidity setpoint. Uses mechanical reheat circuit in units with "D" option in unit nomenclature.
Ventilation Operation	Dedicated ventilation output (A). Scheduled occupancy operation.
Programmed Occupancy Schedule	7 Day, 5 + 2 Day, or non-programmable. Up to 4 events per day.
Power Loss Features	No Batteries. Permanently retains setpoints/setup. Time/date for min. 8 hrs.
Emergency Heat	Manually enabled in thermostat menu. Compressor lockout while enabled.
Hold function	Vacation or Permanent mode.
Outdoor Sensor (10K-Ohm)	Bard Part #8403-061. Needed for cooling, electric heat, heat pump lockout.
Cooling Lockout Range	40°F to 55°F (4°C to 13°C)
Electric Heat Lockout Range	5°F to 60°F (-15°C to 15°C)
Heat Pump Lockout Range	5°F to 50°F (-15°C to 10°C)
Indoor Sensor (10K-Ohm)	Bard Part #8403-062. Needed for Remote sensor only or sensor averaging.
Smart Recovery Mode for Energy Efficiency.	Enabled or disabled. If enabled slowly adjusts temperatures when transitioning to scheduled occupancy temperature setpoints.
Security Lockout Options	Temperature only, temperature and mode only, total keypad lockout.
Test Mode Operation	Manual operation of all outputs to test unit and field wiring.
Service Information	Input, temperature, and system status.
Service Information Runtime Tracking	Air filter, humidifier, UV lamp, air cleaner reminder based on operating time.
Differential Offset from Setpoint	Default is 2°F, adjustable between 1°F and 4°F.
Thermostat Color	Off-White
Screen	LCD, Light blue backlight for 30, 60, 90, 120 seconds or continuous.
Size	6.25" x 4.25" x 1.25" (15.875cm x 10.795cm x 3.175cm)
Units	F° or C°
Field Wiring to Unit	22AWG min, 18AWG recommended. Shielded twisted pair for ext. sensors.

Controller Dimensions

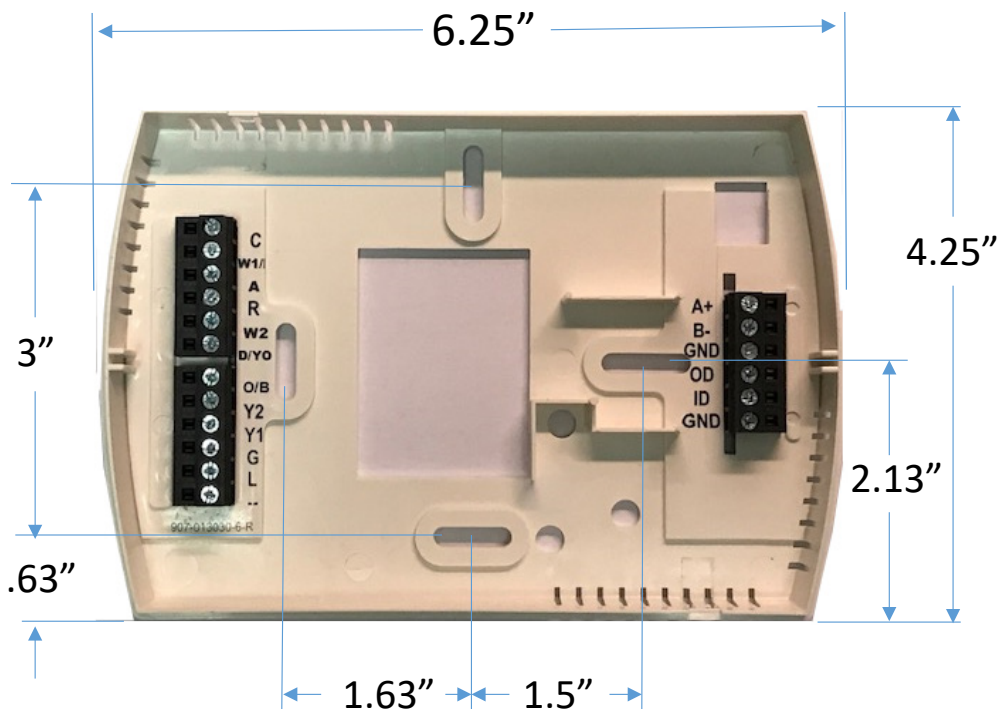

Controller Interface and Setup Screens

Setup screens are easy to navigate with the arrow keys and enter button. The main display shows all essential information needed to indicate unit operation and thermostat setpoints. Main menu items are easily accessible, and installer settings are available in an additional menu that is hidden for the standard user. Password protection allows lockout of various functions and menus.

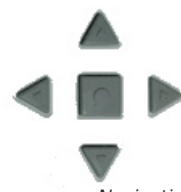

Navigation Buttons

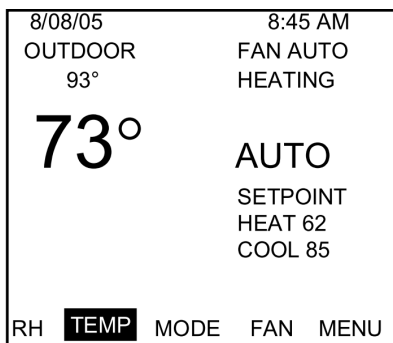

Main Display

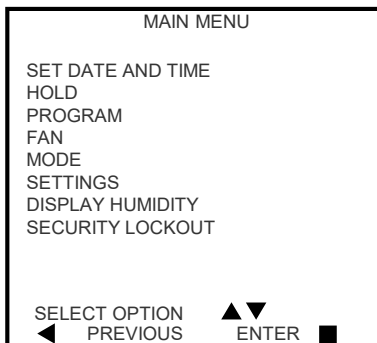

Main Menu

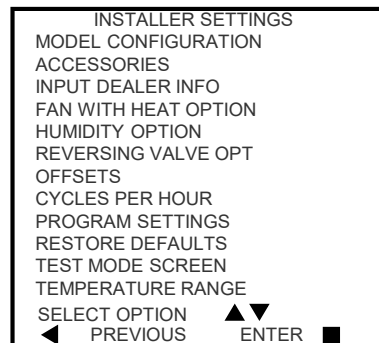

Installer Settings

Controller Connections and Operation

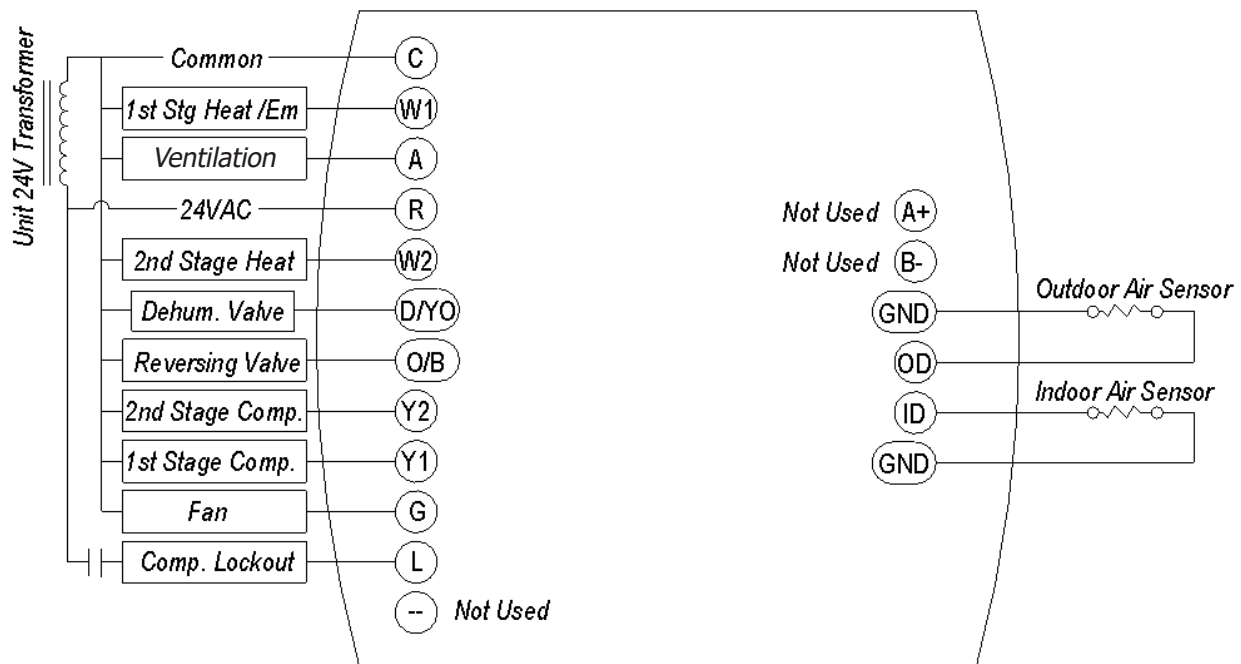

24VAC CONNECTIONS

- C – 24V Common for Control Circuit
- R – 24V Supply for Control Circuit
- W1/E – E Heat/ First Stage Heat
- W2 – Second Stage Heat
- O/B – Reversing Valve - energized in HEAT mode(B is default)
- Y1 – 1st Stage Compressor / Cooling / Heating
- Y2 – 2nd Stage Compressor / Cooling / Heating
- YO/D – Economizer / Dehumidifier output *
- A – Ventilation Output
- G – Fan
- L – Input for CS2000A or compressor fault
- A+, B – Not Used.
- GND – Ground **
- OD – Outdoor Temperature Sensor **
- ID – Indoor Temperature Sensor **

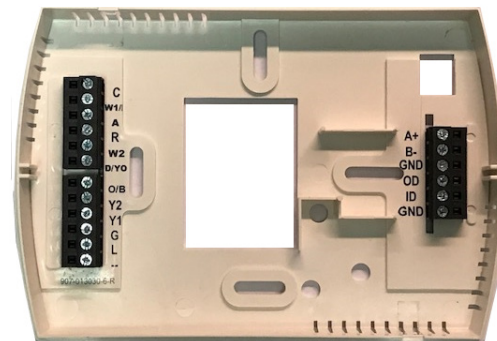

*Controller must be configured for “No Economizer” for dehumidification control to be active.

**Shielded twisted pair should be used for remote Indoor and Outdoor Sensors to avoid any possible interference from other electrical systems or other external sources. The shield (drain) should be connected to 24V Common (C) at the controller.



Bard Manufacturing Company, Inc.
Bryan, Ohio 43506
www.bardhvac.com

Due to our continuous product improvement policy, all specifications subject to change without notice.

Before purchasing this appliance, read important energy cost and efficiency information available from your retailer.

Form No.
S3570
August 2018

Supersedes: 518