

# zenitel

VINGTOR  STENTOFON PHONTECH



## VINGTOR-STENTOFON & PHONTECH MARITIME & ENERGY PRODUCT CATALOG

**BECAUSE**

 when communication is critical

# zenitel

Vingtor-Stentofon and Phontech products are developed by the Zenitel Group and include a range of high quality communications equipment and systems. Being in business since 1901, Zenitel's products are recognized globally for offering high quality communications for both offshore and onshore installations. On November 1, 2018, Zenitel Group acquired the Phontech business and products from Jotron AS. Primary system offerings within the Vingtor-Stentofon and Phontech portfolios are: Public Address & General Alarm, Telephony and Intercom, Special Communications Equipment, Wireless Communication, Info & Entertainment System. Zenitel and the company's global partner network, also integrate these systems with other security devices including Radio, CCTV, Access Control and Alarm for a comprehensive security solution.

Zenitel is world-renowned for its extensive knowledge in the design, construction, installation and maintenance of integrated marine communication systems incorporating Vingtor-Stentofon and Phontech products. Leveraging our long-term experience serving the maritime industry, we offer an impressive portfolio and provide cutting edge solutions to marine vessels worldwide under the brand names of Vingtor-Stentofon and Phontech. Both these brands underpin our reputation as a supplier of the most flexible, reliable and advanced communication systems available today.

## **MEETING YOUR REGULATORY REQUIREMENTS**

All Vingtor-Stentofon and Phontech products that form a part of critical communication have been tested according to IEC 60945, IEC 60533 standards, and comply with SOLAS regulations and codes relevant to on-board communication systems. Our systems are delivered in accordance with the rules of all major classification societies.

## **FOR ALL YOUR SALES & AFTER SERVICE REQUIREMENTS**

Zenitel is a specialist provider of spare parts, repairs, maintenance contracts and refit solutions. Responsibility and availability are our guidelines and customer support and service a first priority.

Zenitel is based in Horten, Norway.

Phone: +47 40 00 25 00

e-mail: [sales@zenitel.com](mailto:sales@zenitel.com)

[www.zenitel.com](http://www.zenitel.com)



<b>Public Address &amp; General Alarm Systems</b>	<b>4</b>
<b>Exigo IP Networked PA/GA</b>	<b>5</b>
<b>SPA-V2 PA/GA</b>	<b>13</b>
<b>MPA 1600 Energy Offshore PA/GA</b>	<b>21</b>
<b>Telephony &amp; Intercom Systems</b>	<b>23</b>
<b>ACM Communication System</b>	<b>24</b>
<b>ICS 6200 Communication System</b>	<b>35</b>
<b>Special Communications Equipment</b>	<b>40</b>
<b>8300 MkII Sound Reception System</b>	<b>41</b>
<b>CIS 3000 Talk-Back System</b>	<b>43</b>
<b>ITCS Hospital &amp; Refrigerator Alarm System</b>	<b>48</b>
<b>VSP Batteryless Telephone system</b>	<b>51</b>
<b>Information &amp; Entertainment Systems</b>	<b>57</b>
<b>Infotainment &amp; IPTV System</b>	<b>58</b>
<b>IP CCTV System</b>	<b>63</b>
<b>Master Clock System</b>	<b>69</b>
<b>Wireless Communication</b>	<b>72</b>
<b>Two-Way Radio Solution</b>	<b>73</b>
<b>IP DECT Solution</b>	<b>79</b>
<b>Common Equipment</b>	<b>83</b>
<b>Loudspeakers</b>	<b>84</b>
<b>Signal Units</b>	<b>89</b>
<b>UPS - Uninterruptible Power Supply</b>	<b>92</b>

# Public Address & General Alarm Systems

<b><u>Exigo IP Networked PA/GA System</u></b>	<b><u>5</u></b>
<b><u>Exigo Central Equipment</u></b>	<b><u>7</u></b>
<b><u>Exigo Indoor Access Panels</u></b>	<b><u>8</u></b>
<b><u>Exigo Outdoor Access Panels</u></b>	<b><u>10</u></b>
<b><u>Exigo Ex Access Panels</u></b>	<b><u>11</u></b>
<b><u>Flowire Cabling</u></b>	<b><u>12</u></b>
<b><u>SPA-V2 PA/GA System</u></b>	<b><u>13</u></b>
<b><u>SPA-V2 Central Equipment</u></b>	<b><u>14</u></b>
<b><u>SPA-V2 Access Panels / Microphones / Volume Controllers</u></b>	<b><u>17</u></b>
<b><u>MPA 1600 Energy Offshore PA/GA</u></b>	<b><u>21</u></b>

# EXIGO

## IP Networked Public Address & General Alarm System

The Exigo system is designed to meet the requirements of Public Address & General Alarm systems for offshore installations, ships and other demanding areas. The system is scalable and offers a set of standard and optional features making it ideal for all kinds of installations.

The Exigo system is a native IP system designed to use any type of network equipment and each device is self-monitoring. The devices themselves will report any faults to the system controller allowing for a centralized monitoring of all connected devices. The system controller is also the integration point for the system and enables a wide variety of integrations spanning from analog integration, digital IP-IP audio integration using SIP to remote monitoring using a SDK/API or SNMP.

The system can also utilize innovative addressable IP loudspeakers. The IP loudspeakers are individually addressable, configurable and monitored. Each IP loudspeaker features a maximum 10-watt audio effect and is powered over the Ethernet connection.

### Features

- Native IP PA/GA system for robust and demanding environments
- Full monitoring of system components, call panels and speaker loops
- Class-D amplifiers with 100/70-volt line and Ethernet interface
- Supports 250 PA zones
- Control inputs and outputs
- Analog audio inputs and outputs
- Mains 115/230 VAC and 24/48 Vdc emergency power with automatic switch over
- Integration with PBX, typhoon and fire alarm
- Supports Integrated PA, GA and intercom solution
- Addressable IP loudspeakers supporting PoE (10 Watts)



Learn more about EXIGO: [www.zenitel.com/exigo-ip-public-address-system](http://www.zenitel.com/exigo-ip-public-address-system)



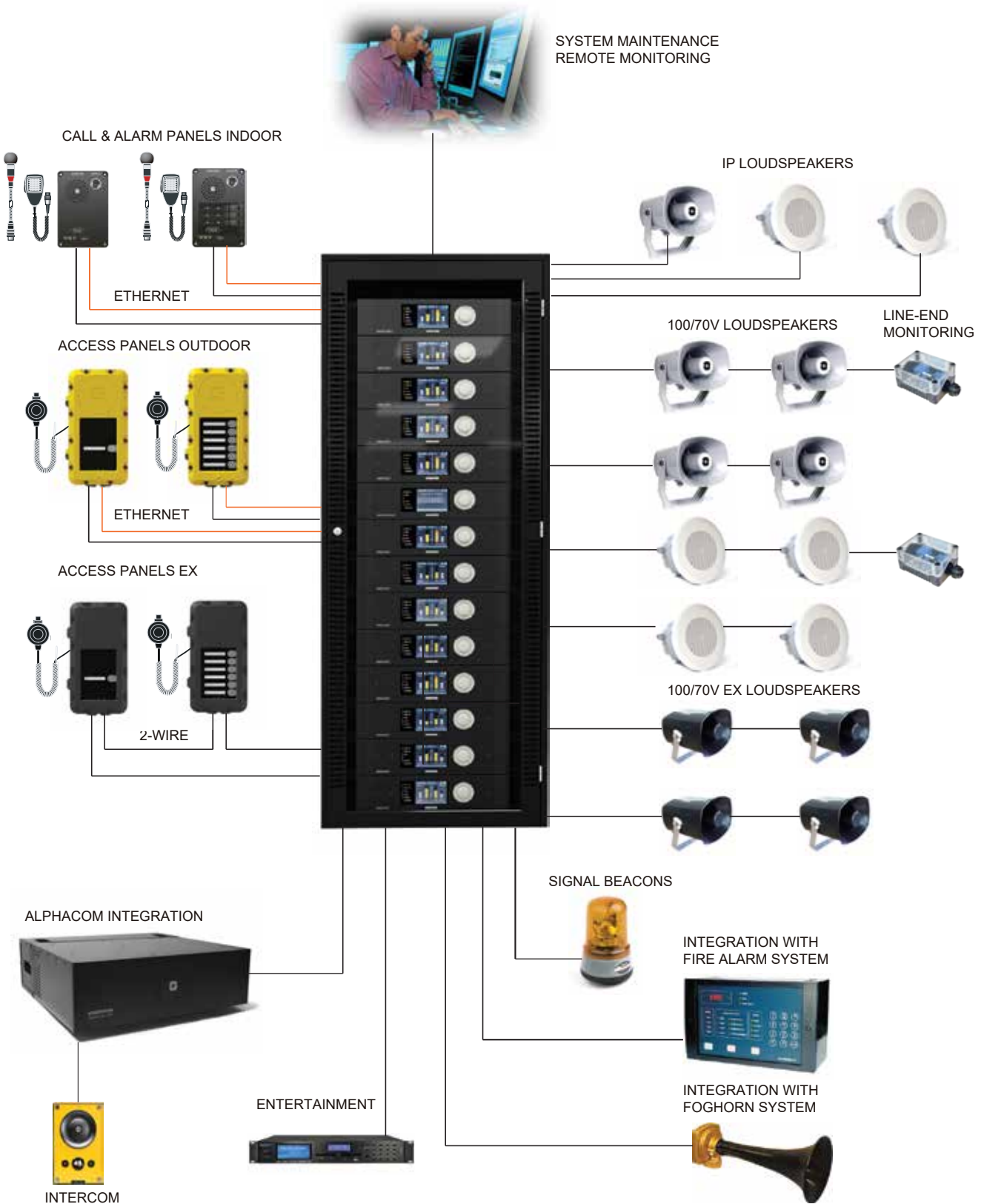

# EXIGO

## Central Equipment



1023000000

### ESC1 EXIGO System Controller

- Control and routing of audio channels
- 115 - 230 VAC primary power and 24 - 48 VDC secondary power
- Redundant Ethernet connections
- Digital audio processing
- Receives, handles and stores fault messages from the system
- Interface to PABX and iPBX
- Interface to telecom management, safety, automation and security systems
- Voice message storage
- Programmable alarm generator
- 6 configurable control outputs
- 6 configurable control input



Size (WxHxD): 482 x 87 x 390 mm Weight: 9.5 kg

Additional Information: IP-32

1023102200

### ENA2200 Exigo Network Amplifier 2 x 200W Power

- 2x 200 watt continuous GA effect
- 2x 200 watt PA effect
- Power efficient class D technology
- 110-230 VAC primary power and 24-48 VDC secondary power
- Redundant Ethernet connections
- Digital audio processing, equalizer and audio delay
- Tick tone generator
- Loudspeaker line monitoring
- Supports up to 10 Intelligent Line End Transponders
- Input for backup amplifier
- 6 configurable control outputs
- 6 configurable control inputs



Size (WxHxD): 482 x 87 x 390 mm Weight: 13.0 kg

Additional Information: IP-32

1023102400 / 1023102410

### ENA2400-DC / ENA2400-AC EXIGO Network Amplifier 2 x 400W Power

- 2x 400W continuous GA effect
- 2x 400W PA effect
- Power efficient class D technology
- Redundant Ethernet connections
- Digital audio processing, equalizer and audio delay
- Tick tone generator
- Loudspeaker line monitoring
- Supports up to 10 Intelligent Line End Transponders
- Input for backup amplifier
- 6 configurable control outputs
- 6 configurable control input
- ENA2400-DC : 48 VDC power
- ENA2400-AC : 110 - 230 VAC power



Size (WxHxD): 482 x 87 x 390 mm Weight: 13.5 kg

Additional Information: IP-32

1023102100

### ENA2100-AC EXIGO Network Amplifier 2 x 100W Power

- 2x 100W continuous GA effect
- Power efficient class D technology
- 115-230 VAC power
- Redundant Ethernet connections
- Digital audio processing
- Embedded tick tone generator
- Loudspeaker line monitoring
- Supports up to 10 Intelligent Line End Transponders
- Line Input
- 2 configurable control outputs
- 2 configurable control inputs



Size (WxHxD): 254 x 87 x 308 mm Weight: 5.75 kg

Additional Information: IP-32

1008095201

### IP-LCM-A IP Line Connection Module with Inputs/Outputs

- Expansion to TKIS-2 that adds high power relays and robust control inputs without extra wiring.
- DIN-rail mounting
- 8 relay outputs
- 8 control inputs
- Robust push-in connectors for cables up to 1.5 mm<sup>2</sup> / 16 AWG
- Device powered via the TKIS-2 kit using PoE or local power
- All TKIS-2 features available



Size (HxWxD): 125.4 x 270.5 x 66.6 mm  
Weight: 1 kg



# EXIGO

## Indoor Access Panels



1023200030

### ECPIR-P Exigo Call Panel, PTT Button, Pluggable Microphone

- Digital call panel for console mounting
- Communication and power over Ethernet
- Separate PTT button
- Indicators for power, call and fault
- Can be used with either handheld or gooseneck microphone
- For single or dual systems
- Up to four EBMDR-8 expansion modules can be connected



Size (WxHxD): 96 x 144 x 50 mm Weight: 0.5 kg

Additional Information: IP-32

1023200033

### ECPIR-3P Exigo Call Panel, PTT + 3 Buttons, Pluggable Microphone

- Digital call panel for console mounting
- Communication and power over Ethernet
- Three programmable buttons with individual labels and status indicators
- Separate PTT button
- Optional button protection covers
- Indicators for power, call and fault
- Can be used with either handheld or gooseneck microphone
- For single or dual systems
- Up to four EBMDR-8 expansion modules can be connected



Size (WxHxD): 96 x 144 x 50 mm Weight: 0.5 kg

Additional Information: IP-32

1023201008

### EAPR-8 Exigo Alarm Panel, 8 Buttons, Ethernet

- Digital alarm panel for console mounting
- Communication and power over Ethernet
- Eight programmable buttons with individual labels and status indicators
- Optional button protection covers
- Indicators for power, call and fault
- For single or dual systems
- Up to four EBMDR-8 expansion modules can be connected



Size (WxHxD): 96 x 144 x 50 mm Weight: 0.5 kg

Additional Information: IP-32

1023253008

### EBMDR-8 Exigo Button Expansion Module, 8 Buttons

- Button expansion module for Exigo access panels
- Powered from master access panels
- Eight programmable buttons with individual labels and status indicators
- Optional button protection covers
- For single or dual systems



Size (WxHxD): 96 x 144 x 50 mm Weight: 0.5 kg

Additional Information: IP-32



1008031000

### CRM-V IP Flush Master Station

- Made for Critical Communication over IP
- Connects directly to the IP network, no geographical limitations
- Large high contrast display with backlight for excellent readability
- White light behind all keys
- Four freely programmable single-touch keys (DAK)
- Superb audio technology
- Optional handset unit
- Remote upgrade, configuration and monitoring
- Note! For single PA system only



Size (WxHxD): 125 x 280 x 30 mm Weight: 0.37 kg

1008010100

### CRM-V-DAK48 Key Expansion Module for CRM-V, 48 keys

- Extends IP Flush Master Station with 48 programmable DAK keys (Direct Access Keys)
- Ideal for PA, talk-back calls
- Visual indications with two LEDs (green/red) per DAK key
- All keys have backlight (adjustable)
- Easy labelling of keys
- Note! For single PA system only



Size (WxHxD): 125 x 280 x 30 mm Weight: 0.65 kg

1008097500

### CRM-V-GN Gooseneck Microphone

- Noise-cancelling gooseneck microphone for CRM-V IP Flush Master station
- Ideal for Public Address and control room applications



Size (WxHxD): 90 x 32 x 45 mm Weight: 0.1 kg

Related items: 1008031000 CRM-V IP Flush Master

## Accessories for Indoor Panels

3005020033

### MB-30G Gooseneck Microphone

- Electret Microphone, 2K ohm
- 5-pin DIN plug
- Microphone for Exigo ECPIR family



Length: 460mm Weight: 0.1kg

Additional information: IP-rating IP-32

1023533012

### PAM1H Mic for ECPIR Panels

- Handheld PA microphone with bracket
- For indoor use
- Push-To-Talk button
- Electret and Noise Cancelling microphone



Size: Length 142 mm, Head Ø 29 mm, Body Ø 24 mm Weight: 0.19 kg Cord length: 1.5 m

Additional Information: IP-66

1023595010

### EMBR-1 Exigo Desktop Mounting Box for 1 Access Panel



Size (WxHxD): 104 x 188 x 74 mm Weight: 0.35 kg

1023595020

### EMBR-2 Exigo Desktop Mounting Box for 2 Access Panels



Size (WxHxD): 201 x 188 x 74 mm Weight: 0.7 kg

Additional information: 1023595060 EMBR-6 Exigo kit for joining Boxes

# EXIGO

## Outdoor Access Panels



1023201201

### EAPII-1 Exigo Industrial Access Panel, 1 Button

- Digital call and access panel for industrial environments
- DSP for acoustic signal processing
- Communication and power over Ethernet
- One programmable button with individual label and status indicators
- Optional button protection cover
- Indicators for power, call and fault
- Embedded or optional handheld microphone
- For single or dual systems (A and B systems)



Size (WxHxD): 178 x 346 x 101 mm Weight: 1.9 kg

Additional Information: IP-66  
1023594100 Optional button protection, info page 10

1023201206

### EAPII-6 Exigo Industrial Access Panel, 6 Buttons

- Digital call and access panel for industrial environments
- DSP for acoustic signal processing
- Communication and power over Ethernet
- Six programmable buttons with individual labels and status indicators
- Optional button protection covers
- Indicators for power, call and fault
- Embedded or optional handheld microphone
- For single or dual systems (A and B systems)



Size (WxHxD): 178 x 346 x 101 mm Weight: 1.9 kg

Additional Information: IP-66  
1023594100 Optional button protection, info page 10

## Accessories for Outdoor Panels

1008140100

### TA-10 Relay Module

- Designed for use with EAPII access panels
- Dual high-power relays (DPDT)
- Up to 400VAC /48 VDC per relay
- Up to 6A current per relay
- Heavy-duty spring-loaded terminals with spare grounding terminals
- Powered by Exigo EAPII access panels or Turbine Extended Kit (TKIE-1)



Size (WxHxD): 100 x 50 x 40 mm Weight: 0.1 kg

1023697006

### EPIPR-6

- Exigo Power Injector, Spare Pair PoE, 6 Ports
- PoE midspan injector supplying up to 15.7W per port for up to 6 devices
- Used for configurations with requirement for redundant A and B systems



Size (WxHxD): 132 x 57 x 32 mm Weight: 0.3 kg

1023533312

### EMMAI-2H Industrial Microphone

- PTT key on handset
- Noise cancelling microphone
- High quality digital background noise reduction
- HD voice compatible
- Designed for use with EAPII access panels



Size (WxHxD): 44 x 68 x 21.5 mm Weight: 0.22 kg

Additional Information: IP-66  
Wall-bracket included

1023540000

### ELTSI-1 Exigo Line End Transponder

- Loudspeaker line end transponder
- Powered from and communicates over the loudspeaker lines
- Small and simple to install
- Rugged and weather-proof housing
- Ensures reliable monitoring of the loudspeaker
- Up to 10 line end transponders may be connected to the same amplifier lines



Size (WxHxD): 80 x 106 x 53 mm Weight: 350 g

Additional Information: IP-67

# EXIGO Ex Access Panels



1023221511

## EAPFX-1 Exigo Industrial Ex Access Panel, 1 Button

- Digital call and access panel for explosive atmospheres
- Ex mb ib e IIC T4 Gb
- DSP for acoustic signal processing
- IP networking and power over Flowire technology
- One programmable button with individual label and status indicators
- Optional button protection covers
- Indicators for power, call and fault
- Embedded or optional handheld microphone
- For single or dual systems (A and B systems)



**Size (WxHxD): 178 x 346 x 101 mm Weight: 3.4 kg**

Additional Information: IP-66  
Ex class Ex mb ib e IIC T4 Gb  
Optional button protection

1023221516

## EAPFX-6 Exigo Industrial Ex Access Panel, 6 Buttons

- Digital call and access panel for explosive atmospheres
- Ex mb ib e IIC T4 Gb
- DSP for acoustic signal processing
- IP networking and power over Flowire technology
- Six programmable buttons with individual labels and status indicators
- Optional button protection covers
- Indicators for power, call and fault
- Embedded or optional handheld microphone
- For single or dual systems (A and B systems)



**Size (WxHxD): 178 x 346 x 101 mm Weight: 3.4 kg**

Additional Information: IP-66  
Ex mb ib e IIC T4 Gb  
Optional button protection

## Accessories for Ex Panels

AK5850HS / 1008150025

## TAX-2B Ex Headset with 10M Cable & Plugbox

- Rugged headset for Ex application
- Noise-cancelling microphone
- High quality digital background noise reduction
- HD-voice compatible
- High quality audio
- Optional in-ear monitors may be connected for added damping in extreme environments
- IP Rating: IP-66
- Standard 4-pole Nexus connector for easy connection/replacement
- Designed for Turbine Ex explosion-proof intercoms
- AK5850HS: Ex-Proof Headset
- 1008150025: TAX-2B Cable & Plugbox



**Weight: 0.4 kg**

Additional Information: IP-66  
1008150025 TAX-2b 10m Cable and Plugbox with PTT for AK5850HS

1023533511

## EMMAX-1H Ex Handheld Mic

- Handheld mic with PTT key for Ex applications
- Curled cord
- Noise cancelling microphone
- High quality digital background noise reduction
- HD voice compatible
- PTT key
- IP-66 Rating
- Designed for Exigo Ex access panels



**Size (WxHxD): 44 x 68 x 21.5 mm Weight: 0.22 kg**

Additional Information: IP-66  
Wall bracket included

1023594100

## EGA-1 Button Protection Covers

- Button Protection Covers (10x) for EAPII/EAPFX



**Size (WxHxD): 26.6 x 20.3 x 4.2**

Additional Information: Set of 10 pieces

## Flowire Cabling

The Flowire Converter enables Ethernet to run on the same two wires as power, enabling simpler cabling and opens up for longer cable hauls.

## Connection to Central Equipment Rack for Outdoor and Ex Access Panels

The Exigo Access Panels can use the 2-wire Flowire system for connection. Flowire is used to extend the Ethernet connection and support power distribution on the 2-wire cabling infrastructure.

The Ex access panel located in the hazardous zone is connected to the central equipment rack located in the safe zone using an Ex certified 2-wire cable.

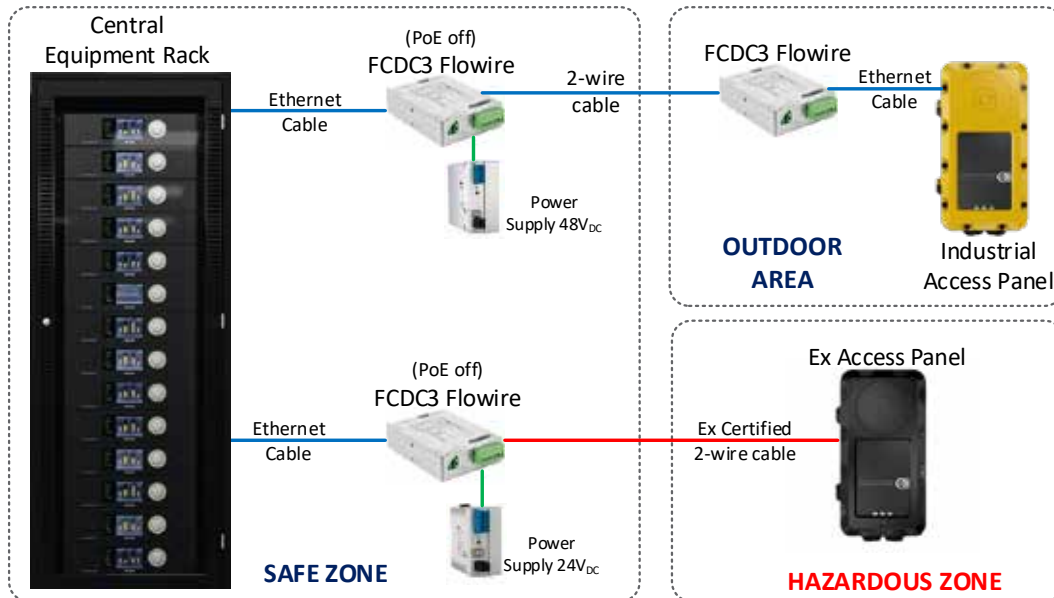

1008080310

### FCDC3 Flowire Ethernet Converter

- One single pair of cable can be used to distribute power and data
- The cable hauls can be longer, up to 2 km, reducing the need for switches and/or repeaters
- Up to 10 Flowire devices can be connected to the same 2-wire cluster star topology
- Existing infrastructure can be used, even though only a single pair is available. This reduces the total cost of retrofit projects
- The Flowire converter can be used with any Ethernet enabled device (not limited to Vingtor-Stentofon products)
- Enable/Disable PoE switch
- Ingress Protection Rating: IP-20
- Important:** 24V DC non-PoE for Ex equipment



Size (WxHxD): 112 x 74 x 26 mm

Weight: 0.3 kg

2990000063 / 2990000064 / 2990000065

### Power Supply 100-240 VAC 24/48VDC

- Switched-mode power supply
- Natural convection cooling when horizontally mounted
- Enclosed for use in switchgear cabinets
- Limited Power Source (LPS) per NEC Class 2
- Bounce-free switching signal (DC 0 K)
- Suitable for both parallel and series operation
- Electrically isolated output voltage (SELV) per EN 60950-1/UL 60950-1, PELV per EN 60204
- GL approval, also suitable for EMC 1 in conjunction with 787-980 Filter Module



Size (WxHxD): 132 x 37 x 128 mm, Weight: 0.92 kg

2990000066

### Power Supply 100-240VAC/48VDC 5A

- Switched-mode power supply
- Natural convection cooling when horizontally mounted
- Enclosed for use in switchgear cabinets
- Limited Power Source (LPS) per NEC Class 2
- Bounce-free switching signal (DC 0 K)
- Suitable for both parallel and series operation
- Electrically isolated output voltage (SELV) per EN 60950-1/UL 60950-1, PELV per EN 60204
- GL approval, also suitable for EMC 1 in conjunction with 787-980 Filter Module



Size (WxHxD): 132 x 37 x 128 mm, Weight: 0.92 kg

## SPA-V2 PA/GA System

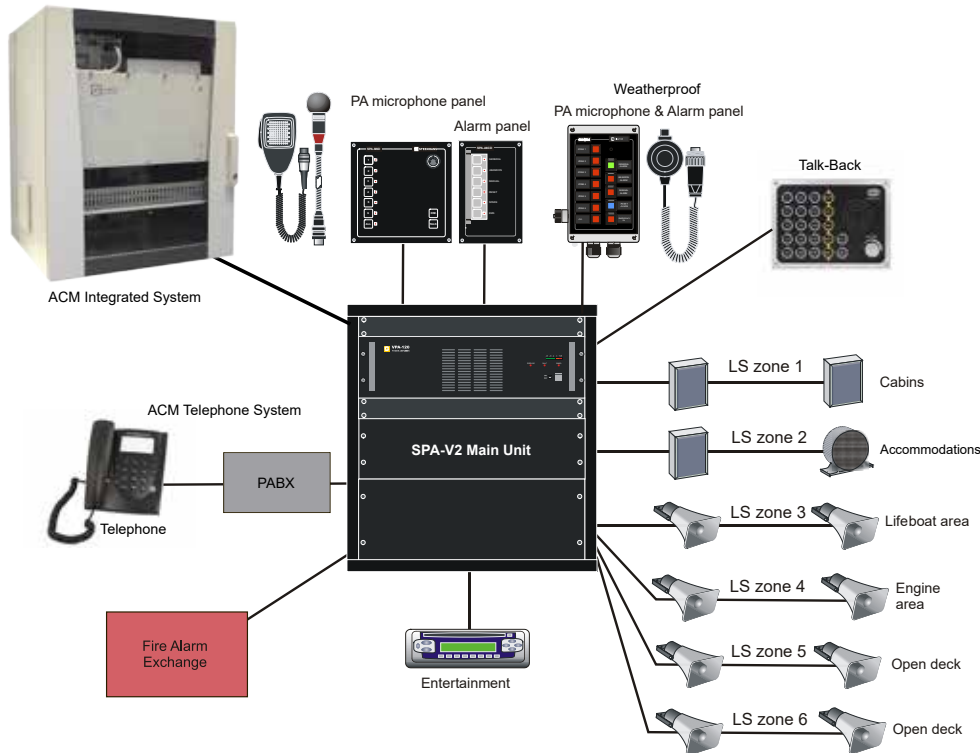

### FEATURES

- Standalone PA & GA system for marine environment
- 19" rack with terminals for ship's cable network
- Power Amplifiers, 100 V line with alternative power output of 120W, 240W or 400W
- Provides monitoring of power amplifiers
- 6 zones selection + ALL
- Can be integrated with ACM system
- Input for 3 microphone panels
- AUX / Alarm input
- Input from Talk-Back system
- Input from PABX (preselected zones)
- Mains 110 - 230 VAC / 24 VDC with auto switch-over
- Built-in pre-amplifiers
- Wide set of microphones and alarm panels

The SPA-V2 system is specially designed to meet the demands for a cost-effective Public Address system for use onboard marine vessels.

The system is available in various versions and offers a set of standard and optional features that covers the requirements for a marine Public Address and General Alarm system for all types of vessels.

Each SPA rack supports power output from 120W up to 2800W. A system can consist of multiple racks to provide for the requisite capacity. The racks can be provided in the following sizes: 12 HU, 16 HU, 20 HU, and 24 HU.

The SPA system is an integrated type-approved PA and GA solution. SPA is extremely cost-effective, where SPA loudspeaker loops are used together with the integrated ACM units to cover areas where PA and GA are required onboard the vessel.

### TYPE APPROVALS

The SPA system is tested according to EN60945, and type approved by DNV-GL, RMRS, CCS, RINA, CRS, Lloyd's Register, ABS, and BV.



# SPA-V2 Central Equipment



3005010079

## SPA-120-V2 PA Main Unit, 19" Rack, 120W VPA Amplifier

- Input & priorities for 3 microphone panels
- Input from talk-back system
- Input from entertainment system
- PABX Input with zone presets
- 6 zones, 100V, 120W signal output
- Input for 2 alarm panels
- 2x Fire alarm input, all call and zone selection (fire crew)
- Alarm mute during PA message



Size (WxHxD): 525 x 600 x 525 mm Weight: 42.0 kg

Additional Information: Base model 12HU  
Feature cards to be specified, see internal accessories

3005010084

## SPA-240-V2 PA Main Unit, 19" Rack, 240W VPA Amplifier

- Input & priorities for 3 microphone panels
- Input from talk-back system
- Input from entertainment system
- PABX Input with zone presets
- 6 zones, 100V, 240W signal output
- Input for 2 alarm panels
- 2x Fire alarm input, all call and zone selection (fire crew)
- Alarm mute during PA message



Size (WxHxD): 525 x 600 x 525 mm Weight: 45.0 kg

Additional Information: Base model 12HU  
Feature cards to be specified, see internal accessories

3005010087

## SPA-400-V2 PA Main Unit, 19" Rack, 400W VPA Amplifier

- Input & priorities for 3 microphone panels
- Input from talk-back system
- Input from entertainment system
- PABX Input with zone presets
- 6 zones, 100V, 400W signal output
- Input for 2 alarm panels
- 2x Fire alarm input, all call and zone selection (fire crew)
- Alarm mute during PA message



Size (WxHxD): 525 x 600 x 525 mm Weight: 48.0 kg

Additional Information: Base model 12HU  
Feature cards to be specified, see internal accessories

2340130005

## SPA-400D-V2 PA Main Unit, 19" Rack, 400W Class-D Amplifier

- Input & priorities for 3 microphone panels
- Input from talk-back system
- Input from entertainment system
- PABX Input with zone presets
- 6 zones, 400W Class-D 100V signal output
- Input for 2 alarm panels
- 2x Fire alarm input, all call and zone selection (fire crew)
- Alarm mute during PA message



Size (WxHxD): 525 x 584 x 525 mm Weight: 50 kg

Additional Information: Base model 19" 12HU

2340130003

## SPA-600D-V2 PA Main Unit, 19" Rack, 600W Class-D Amplifier

- Input & priorities for 3 microphone panels
- Input from talk-back system
- Input from entertainment system
- PABX Input with zone presets
- 6 zones, 600W Class-D 100V signal output
- Input for 2 alarm panels
- 2x Fire alarm input, all call and zone selection (fire crew)
- Alarm mute during PA message



Size (WxHxD): 525 x 584 x 525 mm Weight: 50 kg

Additional Information: Base model 19" 12HU



1023131400

### EA1400 Exigo Amplifier 1 x 400W

- 1x 400 watt continuous effect
- Power efficient class D technology
- 110-230 VAC power
- Loudspeaker line monitoring



**Size (WxHxD):** 87 x 482 x 308 mm 19" 2HU  
**Weight:** 10 kg

1023131600

### EA1600 Exigo Amplifier 1 x 600W

- 1x 600 watt continuous effect
- Power efficient class D technology
- 110-230 VAC power
- Loudspeaker line monitoring



**Size (WxHxD):** 87 x 482 x 308 mm 19" 2HU  
**Weight:** 10 kg

3005010235

### VPA-120 Power Amplifier, 120W

- Power amplifier in a 19" rack cabinet
- 100 V and 8 ohm output
- Dual inputs with priority switching
- Temperature controlled, forced back-to-front ventilation
- 115/230 VAC mains and 24 VDC battery backup
- Power consumption at 0dB 24V DC 7,5 A
- Power consumption at 0dB 230V AC 1.7 A
- Pilot tone line monitoring
- 24 VDC / 800 mA power output for external equipment
- Chime signal with on/off switch



**Size (WxHxD):** 482 x 133 x 420 mm "3HU"  
**Weight:** 18.2 kg

Additional Information: Requires 4HU in rack  
 Tested according to EN 60945, IACS E10, IEC 60533

3005010237

### VPA-240 Power Amplifier, 240W

- Power amplifier in a 19" rack cabinet
- 100 V and 8 ohm output
- Dual inputs with priority switching
- Temperature controlled, forced back-to-front ventilation
- 115/230 VAC mains and 24 VDC battery backup
- Power consumption at 0dB 24V DC 15,4 A
- Power consumption at 0dB 230V AC 3.1 A
- Pilot tone line monitoring
- 24 VDC / 800 mA power output for external equipment
- Chime signal with on/off switch



**Size (WxHxD):** 482 x 133 x 420 mm "3HU"  
**Weight:** 21.2 kg

Additional Information: Requires 4HU in rack  
 Tested according to EN 60945, IACS E10, IEC 60533

3005010239

### VPA-400 Power Amplifier, 400W

- Power amplifier in a 19" rack cabinet
- 100 V and 8 ohm output
- Dual inputs with priority switching
- Temperature controlled, forced back-to-front ventilation
- 115/230 VAC mains and 24 VDC battery backup
- Power consumption at 0dB 24V DC 28,0 A
- Power consumption at 0dB 230V AC 5.4 A
- Pilot tone line monitoring
- 24 VDC / 800 mA power output for external equipment
- Chime signal with on/off switch



**Size (WxHxD):** 482 x 133 x 420 mm "3HU"  
**Weight:** 24.2 kg

Additional Information: Requires 4HU in rack  
 Tested according to EN 60945, IACS E10, IEC 60533



3005010184

### SPA-SWITCH-V2 Monitor with Line Selector & Program Switch

- 6 Line input selector
- Monitoring for six amplifiers
- Entertainment input for six sources
- On/Off for entertainment
- Volume adjustment of line output signal with amplifier
- 24VDC supply
- All input/output terminals in back side
- 19" rack mounted 2 HU



**Size (WxH): 483 x 89 mm**  
**Weight: 0.65 kg**

Additional Information: Optional entertainment sources, assembly included

3005010173

### SPA-RCD Radio/CD Player including Rack Expansion - 2U

- FM with RDS / MW / CD / MP3
- Mono-mixed 0dB output
- Delivered with power supply 230V AC /12V DC



**Size (WxH): 483 x 89 mm**

Additional Information: Optional entertainment source, assembly included

3005010169

### SPA-PABXR-V2 PABX Recall Voice Recorder

- Recall voice recorder for PABX interface
- Using DTMF tone from PABX
- Up to 6 different zones or All can be given



**Size: 19" wide, 1HU high**

Additional Information: Assembly included

3005010185

### SPA-SWITCH-V3 Monitor with Line Selector & Program Switch

- 6 Line input selector
- Monitoring for six amplifiers
- Entertainment input for six sources
- On/Off for entertainment
- Volume adjustment of line output signal with amplifier
- 24VDC supply
- All input/output terminals in back side
- 19" rack mounted 2 HU
- Entertainment input 2 and 3 have each built-in preamplifier with volume adjustment for the input signal



**Size (WxH): 483 x 89 mm** **Weight: 0.65 kg**

Additional Information: Optional entertainment source, assembly included

2329990004

### DN-500BD-MKII Blu-Ray & DVD Player Rackmount 19" - 1HU

- Blu-Ray disc and media player
- Compact, high performance unit
- Handles all popular optical video and audio CD playback formats from single disc playback device.
- Front-loading SD and USB ports deliver access to video, audio and picture files such as AVI, MOV, MP4, MP3, WAV, FLAC, GIF, JPEG, and PNG.
- Power: 120 VAC, 60 Hz / 230 VAC, 50 Hz

Supported Disc Formats:

- Blu-ray Disc: BD25, BD50, BD-ROM, BD-R, BD-RE
- DVD: DVD, DVD+R, DVD-R, DVD+RW, DVD-RW
- CD: CD, CD-R, CD-RW, DTS Music Disc (DTS Audio CD, 5.1 Music Disc), HDCD, Super Video CD (SVCD), Video CD (VCD)



**Size (WxHxD): 482 x 44 x 269 mm "1HU"**  
**Weight: 2.3 kg**

3005010111

### SPA-DARP-16 Digital Audio Recorder/Player

- 7 different messages
- Maximum memory capacity 960 seconds.
- Front panel with key access to operate the device manually
- LEDs for status indication and message selection
- Protected stop-button to cancel ongoing messages
- Microphone and aux line inputs for recording
- Rear panel with connectors for remote control/ switches.
- Potential-free switching for message indication.



**Size: 19" wide, 1HU high** **Weight: 2.8 kg**

Additional Information: 2340110008 SPA-DARP-MIC Recording microphone Dynamic XLR-3pin. Remote panel for SPA-DARP-16 is SPA-REM7. Assembly included

# Access Panels Microphones Volume Controllers



3005010150

## SPA-M1-V2 PA Panel Single for All Call, Flush

- PA Panel for single system, all call
- Built-in pre-amplifier with preset signal level and tone controls
- Flush mounting, back box for wall mounting is available
- Local mute contact for external loudspeaker



Size (WxHxD): 144 x 144 x 82 mm Weight: 0.5 kg

Additional Information: IP-44

2340110019

## SPA-M1-D PA Panel Dual for All Call, Flush

- PA Panel for dual system, all call
- Built-in pre-amplifier with preset signal level and tone controls
- Flush mounting, back box for wall mounting is available
- Local mute contact for external loudspeaker



Size (WxHxD): 144 x 144 x 82 mm Weight: 0.5 kg

Additional Information: IP-44

2340110021

## SPA-M6-D PA Panel Dual with 6 Zones, All Call and Dimmer

- PA panel for dual system
- Built-in pre-amplifier with preset signal level and tone controls
- 6 zone selection buttons
- ALL, TALK and dimmer buttons.
- Replaceable text label for each zone button
- Zone buttons have activation confirmation light
- Flush mounting, back box for wall mounting is available
- Local mute contact for external loudspeaker



Size (WxHxD): 144 x 144 x 82 mm Weight: 0.5 kg

Additional Information: IP-44

2340110020

## SPA-M6-V2 PA Panel Single with 6 Zones, All Call and Dimmer

- PA panel for single system
- Built-in pre-amplifier with preset signal level and tone controls
- 6 zone selection buttons
- ALL, TALK and dimmer buttons.
- Replaceable text label for each zone button
- Zone buttons have activation confirmation light
- Flush mounting, back box for wall mounting is available
- Local mute contact for external loudspeaker



Size (WxHxD): 144 x 144 x 82 mm Weight: 0.5 kg

Additional Information: IP-44

3005010095

### SPA-AC6 Single Alarm Panel

- Alarm panel for single system
- Activating abandon, general or manual alarms
- Alarm reset button
- Replaceable text label for each button
- Separate Emergency button (EMS) for PA-message.
- Hinged transparent protecting cover all buttons
- To be used together with SPA-M6
- Flush mounting, back box for wall mounting is available
- Can start three alarms and emergency message in SPA-V2 PA/GA



Size (WxHxD): 96 x 144 x 82 mm Weight: 0.4 kg

Additional Information: IP-44

3005010096

### SPA-AC6-D Dual Alarm Panel

- Alarm panel for dual system
- Activating abandon, general or manual alarms
- Alarm reset button
- Replaceable text label for each button
- Separate Emergency button (EMS) for PA-message.
- Hinged transparent protecting cover all buttons
- To be used together with SPA-M6D
- Flush mounting, back box for wall mounting is available
- Can start three alarms and emergency message in SPA-V2 PA/GA



Size (WxHxD): 96 x 144 x 82 mm Weight: 0.4 kg

Additional Information: IP-44

2340300002

### SPA-AC1P General Alarm Button

- Push Button for Activating general alarms
- Button cover
- Flush mounting
- Back box for wall mounting is available

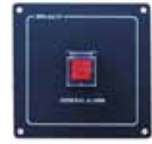

Size (WxHxD): 96 x 96 x 82 mm Weight: 0.25 kg

Additional Information: 3005010105 SPA-BOXM1 wall mounting box

2340300001

### SPA-AC1PW General Alarm Button

- Push Button for Activating general alarms
- Button cover
- Wall mounting
- Watertight



Size (WxHxD): 110 x 80 x 63 mm Weight: 0.53kg

Additional Information: IP-66

3005010199

### SPA-W1-V2 Weatherproof PA Panel for Outdoor Use

- Weatherproof PA panel for single system
- Built-in pre-amplifier with preset signal level and tone controls
- Microphone with PTT
- Contact for WP handheld microphone P-66 or P-66/10
- Wall mounting outdoors/indoors
- Local mute contact for external loudspeaker



Size (WxHxD): 140 x 230 x 125 mm Weight: 0.5 kg

Additional Information: IP-66

3005010197

### SPA-W1-D Weatherproof PA Panel for Outdoor Use

- Weatherproof PA panel for dual system
- Built-in pre-amplifier with preset signal level and tone controls
- Connector for WP handheld microphone P-66 or P-66/10
- Wall mounting outdoors/indoors
- Local mute contact for external loudspeaker



Size (WxHxD): 140 x 230 x 125 mm Weight: 0.5 kg

Additional Information: IP-66

3005010196

### SPA-W1AR-V2 Weatherproof PA and Alarm Panel for Outdoor Use

- Weatherproof PA and Alarm Panel for single system
- General or manual alarms
- Built-in pre-amplifier with preset signal level and tone controls.
- Buttons with hinged transparent protecting cover
- Connector for WP handheld microphone P-66 or P-66/10
- Replaceable text label for each button
- Wall mounting outdoors/indoors
- Local mute contact for external loudspeaker



Size (WxHxD): 140 x 230 x 125 mm Weight: 0.5 kg

Additional Information: IP-66

3005010195

### SPA-W1AR-D Dual Weatherproof PA & Alarm Panel

- Weatherproof PA and Alarm Panel for Dual system
- General or manual alarms
- Built-in pre-amplifier with preset signal level and tone controls.
- Buttons with hinged transparent protecting cover
- Connector for WP handheld microphone P-66 or P-66/10
- Replaceable text label for each button
- Wall mounting outdoors/indoors
- Local mute contact for external loudspeaker



Size (WxHxD): 140 x 230 x 125 mm Weight: 0.5 kg

Additional Information: IP-66

3005010202

### SPA-W6A4 Weatherproof PA & Alarm Panel, 6 Zones

- Weatherproof PA and Alarm panel for single system
- Abandon, general or manual alarms
- Contact for WP handheld microphone P-66 or P-66/10
- Built-in pre-amplifier with preset signal level and tone controls.
- 6 zone selection buttons
- Alarm buttons with hinged transparent protecting cover for protection against unauthorized use
- Microphone with PTT
- Connector for WP handheld microphone P-66 or P-66/10
- Replaceable text label for each button.
- Wall mounting, outdoor or indoor
- Local mute contact for external loudspeaker



Size (WxHxD): 140 x 230 x 125 mm Weight: 0.7 kg

Additional Information: IP-66

3005010203

### SPA-W6A4-D Dual Weatherproof PA & Alarm Panel, 6 Zones

- Weatherproof PA and Alarm panel for single system
- Abandon, general and manual alarms
- Contact for WP handheld microphone P-66 or P-66/10
- Built-in pre-amplifier with preset signal level and tone controls.
- 6 zone selection buttons
- Alarm buttons with hinged transparent protecting cover for protection against unauthorized use
- Microphone with PTT
- Connector for WP handheld microphone P-66 or P-66/10
- Replaceable text label for each button.
- Wall mounting, outdoor or indoor
- Local mute contact for external loudspeaker



Size (WxHxD): 140 x 230 x 125 mm Weight: 0.7 kg

Additional Information: IP-66

3005010172

### SPA-PROG4-RDF Entertainment Program Selector, Dual Failsafe

- Selector for 4x 100V entertainment programs
- PA input 100V from dual A-B system
- PA override 24VDC input failsafe from dual A-B system and for single system by DIP switch
- 2 common outputs 100V for dual A-B system



Size (WxHxD): 144 x 144 x 82 mm Weight: 0.4 kg

Additional Information: IP-22

3005010024

### ENT-4F Bedside Type Panel

- Entertainment panel
- Input for 4 program sources 100V
- Program selector and volume control
- Input for emergency line 100V
- Input for 24VDC failsafe override



Size (WxHxD): 252 x 100 x 59 mm Weight: 0.475 kg

Additional Information: IP-22

3005010205

### SPA-WIRELESS-MIC ACT-51B 1-Channel Receiver with ACT-52H Hand Microphone

- 2x Antennas
- Power supply External AC Adapter, 12-15V DC, 1A
- Rack mounting kit, optional



Size receiver (WxHxD): 210 x 44 x 206 mm Weight: 0.7 kg Microphone 0.2 kg

3005010204

### SPA-WIRELESS/D Dual ACT-52B Wireless Receiver w/ 2 ACT-52H Wireless Hand Microphone

- 2x Antennas
- External 100-240V AC Switching Power Supply
- Rack mounting kit, optional



Size receiver (WxHxD): 210 x 44 x 206 mm Weight: 0.9 kg Microphone 0.2 kg

2340110029

### SPA-ANT Dual External Antenna AT-70W Set for SPA-WIRELESS

- Antenna set for SPA-WIRELESS/D and SPA-WIRELESS-MIC



Size (WxHxD): 120 x 261 x 32 mm Weight: 0.2 kg

3005020039

### P-66 Waterproof Hand Microphone

- Weatherproof, salt water resistant handheld microphone
- Suitable for heavy-duty outdoor operation subject to noise disturbance
- Delivered with 2 meter flexible cable and plug
- For use in Public Address System and Talk-Back



Size (WxHxD): 54 x 82 x 55mm Weight: 0.3 kg

Additional Information: IP-54

3005020040

### P-66/10 Waterproof Hand Microphone with 10-m Cable

- Weatherproof, salt water resistant handheld microphone
- Suitable for heavy-duty outdoor operation subject to noise disturbance
- Delivered with 10-meter cable and plug
- For use in Public Address System and Talk-Back



Size (WxHxD): 54 x 82 x 55mm Weight: 0.3 kg

Additional Information: IP-54

3005020029

### ETC-1-TB Hand Microphone with 5-Pin DIN Plug

- Dynamic, 200 ohm
- Flexible cord with PTT switch
- Hang up clip



Size (WxHxD): 58 x 102 x 47mm Weight: 0.2 kg

Additional Information: IP-22

3005020033

### MB-30G Gooseneck Microphone

- Electret Microphone, 2K ohm
- 5-pin DIN plug
- Microphone for SPA-V2 access panels



Length: 460mm Weight: 0.1kg

Additional information: IP-rating IP-32

3005010211 / 3005010212

### VM15-RD / VM15-RDF Dual Volume Control, 2x 15W

- Dual volume control, 4 wire override 2x 15W
- For use in SPA-V2 Public Address & General Alarm system
- For flush mounting
- Optional, wall mounting by using back box
- VM15-RDF: Failsafe override



Size (WxHxD): 144 x 144 x 82 mm Weight: 0.7 kg

Additional Information: Backbox STBOKS5

3005010214 / 3005010215

### VM50-RD / VM50-RDF Dual Volume Control, 2x 50W

- Dual volume control, 4 wire override 2x 50W
- For use in SPA-V2 Public Address & General Alarm system
- For flush mounting
- Optional, wall mounting by using back box
- VM50-RDF: Failsafe override



Size (WxHxD): 144 x 144 x 82 mm Weight: 0.7 kg

Additional Information: Backbox STBOKS5

2131000401 / 2131000403

### VCOR-15 Volume Controller, 24VDC Override, 15W, White

- 15W Volume Controller
- 24VDC override relay
- Fail-safe relay option available
- 2131000401: VCOR-15
- 2131000403: VCOR-15F



Size (WxHxD): 87 x 87 x 67.5 mm Weight: 0.2 kg

3005010124

### SPA-EE3-V2 Single Alarm Generator with 3 Alarm Tones

- The module has a microprocessor that administers the alarm tones and sets up the inputs and outputs
- A selector can set all required configuration of alarm tones
- The module has three start inputs and three outputs for relay or lamps
- Interconnections to main terminal board by RJ45 8-pin plug



Size: 19" 1HU Weight: 0.5 kg

Additional Information: Mounted on 1HU ventilation panel, assembly included. 1190900101 SPA-EE3-V2/PROG Custom alarm tone programming for EE3-V2.

3005010121

### SPA-EE3D-V2 Alarm Generator Set for Dual System

- Consists of 2x SPA-EE3 and 1x SPA-EE3 DUAL
- A selector can set 15 different configuration of alarm tones.
- The module has three start inputs and three outputs for relay or lamps
- Interconnections to main terminal board by RJ45 8-pin plug
- Mounted on 1HU 19" ventilation panel



Size: 19" 1HU

Additional Information: Mounted on 1HU ventilation panel, assembly and customized programming included.

2131000402 / 2131000404

### VCOR-60 Volume Controller, 24VDC Override, 60W, White

- 60W Volume Controller
- 24VDC override relay
- Fail-safe override relay option available
- 2131000402: VCOR-60
- 2131000404: VCOR-60F



Size (WxHxD): 87 x 87 x 67.5 mm Weight: 0.2 kg





## MPA 1600 Energy Offshore PA/GA System

MPA 1600 Energy is a Public Address & General Alarm (PA/GA) system designed to meet the requirements of alarm and message distribution onboard mobile and fixed offshore units. The system conforms to SOLAS, IMO, and IEC regulations as well as NORSOK standards T001, T003, and T100. The system consists of two central units using A+B configuration for redundancy. Each system is bespoke, being built and tested to meet the client's exact demands with power output, access points, functionality and interfacing limited only by required usage.

### Features

- Maximum 6 zones
- Priority defined access
- Selected or predefined zones (substation dependent)
- Local mute or speech-delayed announcements
- External inputs: PABX, UHF radio, automatic alarms
- External outputs: extra signal devices, audio recorders, status signals (SNMP)
- Loudspeaker Monitoring System (LMS)
- Compact 1U class D amplifiers – Hot pluggable



4000019120

### P-1643 I.S. Operator Unit

- Intrinsically Safe Operator Unit
- Designed for wall mounting in hazardous areas (also available with gooseneck microphone)
- Intrinsically safe by use of barriers
- Nemko Certification.: 03ATEX1503X and 03ATEX1505X



Size (WxHxD): 360x90x160 mm Weight: 5 kg

4000014310

### P-1308 I.S. Microphone Unit

- Intrinsically Safe Microphone Unit designed for wall mounting in hazardous areas.
- DNV/ABS/RMRS/CCS type approved and compatible with NORSSOK standards.
- Connection for redundant A and B systems
- To be connected through I.S. barrier
- Predefined zones setup
- Weather proof
- Ex ia IIB T6 Gb



Size (WxHxD): 160x160x90 mm Weight: 2.5 kg

4000016818

### P-1601 PAGA Control Unit

- Microphone option is gooseneck
- 6 zones selection keys
- PA (normal paging) key
- Emergency PA key marked with red color and protected against unauthorized use by means of time-trap functionality
- Dimmer key
- Status LED for system A and system B
- LED indicators for all keys
- Dimmable backlight and indication LEDs
- Local mute relays



Size (WxHxD): 144x144x43 mm Weight: 0.6 kg

4000016817

### P-1603 Alarm Control Panel

- 4 alarm keys marked with the text "ALARM" and red color
- Cancel key
- Protection against unauthorized use by means of time-trap functionality (the alarm keys and the cancel keys must be held for 1 sec. before activation)
- 6 LEDs indicating alarm status in each zone
- LED indicators for all keys
- Dimmable backlight and LEDs, remotely controlled from the adjacent MPA P-1601 Control Unit



Size (WxHxD): 144x96x40 mm Weight: 0.5 kg

4000019611

### P-1671 Power Amplifier

- 19" 1U rack mounting
- Low weight
- Low power consumption
- Two balanced audio inputs. Line level XLR with output loop, configurable E and M input
- 250W / 100V line output
- Failure status output NO/NC
- Speaker / line level overvoltage protection
- Short circuit / current limit protected
- Status reporting via MPA 1600 (RCMS/SNMP interface)



Size: 19" 1U rackmount (272mm depth) Weight: 5.5 kg

4000016435

### P-1600 MPA Central Unit

- Flexible system configuration
- Prepared for seamless amplifier or full duplication
- Up to 6 zones selectable in any configuration
- Up to 24 control units, full facility
- Up to 2 emergency microphone inputs
- External paging facility (from ICS6200/PABX etc.)
- Interface to manual or automatic alarm generation
- 2 entertainment sources, free zone selection
- Signal processing
- Preselectable priority levels
- Unlimited amplifier expansion
- Facility for muting local loudspeaker during paging
- Output for mute of external GA system
- Output for activation of external GA system
- Synchronization of external GA tones
- Up to 8 different alarms with priority (optional)
- Chime/ding-dong generator
- Alarm light signal activation (optional)
- Mute of external alarm facility (optional)



Size: 19" 1U (HxW)144x144mm Weight: 5 kg



# Telephony & Intercom Systems

<b><u>ACM Communication System</u></b>	<b><u>24</u></b>
<b><u>ACM Integrated Communication System</u></b>	<b><u>25</u></b>
<b><u>ACM Advanced Communication System</u></b>	<b><u>27</u></b>
<b><u>ICS 6200 Integrated Communication System</u></b>	<b><u>35</u></b>

# ACM Communication Systems

The Vingtor-Stentofon ACM system unites and enhances a vessel's safety systems by providing outstanding on-board communication. The ACM solutions have two main system variants.

These are:

- **ACM Integrated Communication System**
- **ACM Advanced Communication System**

The ACM systems provide reliable, robust and proven communication solutions. The systems have been continuously developed and enhanced to take advantage of new technologies such as IP Networking. The various ACM systems are built around the AlphaCom XE intercom server/exchange. The AlphaCom server/exchange is an advanced communication switch designed to meet the growing needs of internal and external communication onboard marine vessels.

AlphaCom XE is a modular and flexible platform, reflected in a product portfolio comprising various system packages. These system packages fulfill the requirements of all vessel types, from small conventional vessels to large advanced ships. (See table on page 5 for a list of capabilities of the various ACM systems.)

## FEATURES

- Typed-approved solution for Two-Way handsfree voice communication and Talk-Back, Public Address and General Alarm
- Two main system packages: ACM Integrated Communication System with PA and GA Solution, ACM Advanced Integrated Communication System
- 1-bit audio technology (20 kHz) ensures correct communication
- Modular and flexible systems supporting all vessel types
- Supports IP DECT and wireless handsets
- Supports IP, digital & analog telephones, and networking
- Redundant power input with auto-switchover between AC and DC power
- Supports remote services using IP and Web technologies

## TYPE approvals

The ACM system is tested according to IEC 60945, and is type-approved by DNV-GL, RMRS, CCS, Rina, PRS, CRS, LR, ABS.



# ACM Integrated Communication System

The ACM Integrated Communication System is specially designed for use onboard marine vessels. The system is based on the AlphaCom XE platform featuring the latest digital technologies such as IP telephony, Web management and IP switching.

The system supports EXIGO and SPA PA&GA solution. Together with the SPA, the system is extremely cost efficient where SPA loudspeaker loops are used together with the ACM intercom stations. The ACM intercom stations are type-approved as integrated PA, GA, telephone, and talk-back units.

The ACM solution supports a wide range of analog, IP and wireless communication terminals made for the marine environment. IP DECT base stations connect directly to the exchange over IP, providing a very cost-efficient solution for deploying a wireless network onboard.

The DECT telephones, IP telephones, and intercom stations have all access to the same set of ACM features. Users will be able to benefit from full accessibility as well as seamless mobility as they can always be contacted regardless of their location on the vessel.

## Features

- Integrated PA and GA solution
- Wide range of audio stations and signal units
- Optional External communication: analog telephone gateway and GSM
- Supports the Billing System
- Remote management and maintenance using IP and Web technologies
- Redundant power input with switchover
- 1-bit digital audio technology
- Typed approved solution for two-way communication, talk-back, Public Address & General Alarm for all vessel types
- Extensive set of features for PBX and emergency communication

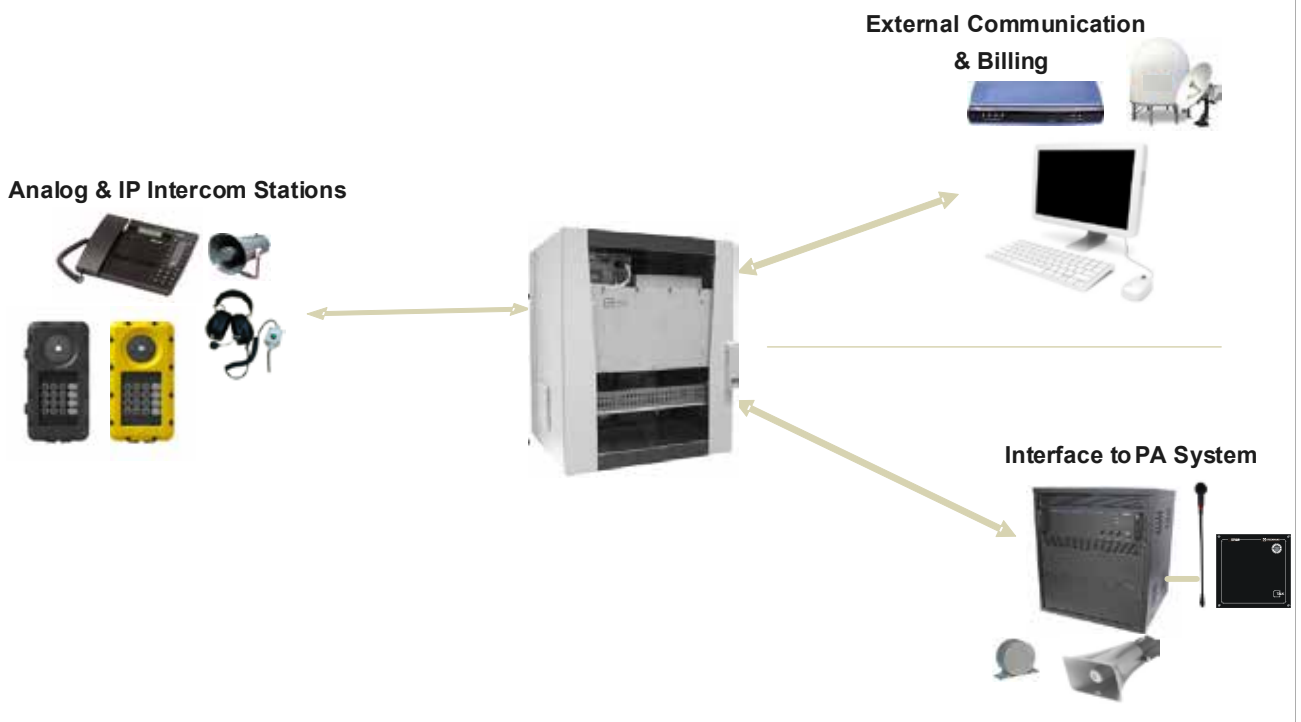

# ACM Integrated System Racks



115010002

## ACM-M-D-V2 System Rack

- Wall mounting
- 8 port switch (6 ports PoE + 2 ports std.) for external equipment, 1 port reserved for AlphaCom connection
- Each exchange can power one additional optional injector kit.
- Prewired for 6 subscriber cards
- Power 230V AC with automatic switch over to 230 VAC UPS or 24V DC Emergency
- 115VAC version on request
- Integrated PA/GA interface (2 inputs, 2 audio ch. Out, 1 audio ch. In)
- 6 relay outputs / 6 potentially free



**Size (WxHxD): 600 x 600 x 350 mm Weight: 45 kg**

Additional Information: Delivered with standard program and documentation. For customized programming /documentation ACM/PROG must be added. IP-22

1150100010

## ACM-48-V10 System Rack

- Wall or floor mounting
- 8 port switch (6 ports PoE + 2 ports std.) for external equipment, 1 port reserved for AlphaCom connection
- Each exchange can power one additional optional injector kit.
- Prewired for 11 subscriber cards
- Power 230V AC with automatic switchover to 230V AC emergency
- 115VAC version on request
- 12 relay outputs
- Integrated PA/GA interface (6 inputs, 4 audio channels Out, 6 audio channels In)
- (PA zone selection require custom programming)



**Size (WxHxD): 600 x 746 x 573 mm Weight: 70 kg**

Additional Information: Delivered with standard program and documentation. For customized programming /documentation ACM/PROG must be added. IP-22

1150100012

## ACM-144-V10 System Rack

- Floor mounting
- 8 port switch (6 ports PoE + 2 ports std.) for external equipment, 1 port reserved for AlphaCom connection
- Each exchange can power one additional optional injector kit.
- Prewired for 17 subscriber cards
- Power 230V AC with automatic switchover to 230V AC emergency
- 18 relay outputs
- Integrated PA/GA interface (6 inputs, 4 audio channels Out, 6 audio channels In) (PA zone selection require custom programming)



**Size (WxHxD): 800 x 1250 x 600 mm Weight: 180 kg**

Additional Information: Delivered with standard program and documentation. For customized programming /documentation ACM/PROG must be added. IP-20

1150100014

## AACM-144 V10 System Rack

- Floor mounting
- 8 port switch (6 ports PoE + 2 ports std.) for external equipment, 1 port reserved for AlphaCom connection
- Each exchange can power one additional optional injector kit.
- Powered for 23 subscriber cards
- Power 230V AC with automatic switchover to 230V AC emergency
- 24 relay outputs
- Integrated PA/GA interface (6 inputs, 4 audio channels Out, 6 audio channels In)(PA zone selection require custom programming)



**Size (WxHxD): 800 x 1250 x 600 mm Weight: 180 kg**

Additional Information: Delivered with standard program and documentation. For customized programming /documentation ACM/PROG must be added. IP-20

**Note!**  
**24V DC emergency for:**

**ACM-48-V10**  
**Use inverter min. 750VA**

**ACM-144-V10**  
**Use inverter min. 1500VA**

**AACM-144 V10**  
**Use inverter min. 1500VA**

# ACM Advanced Communication System

The ACM Advanced Communication System offers a complete system for Communication, Data, Safety, and Entertainment. The system comes with benefits such as reduced costs in infrastructure, more efficient operation, improved user experience and the security of type-approved and certified systems.

The function modules are integrated and assembled into 19" racks specially made for the marine environment. With the modular building platform, the system can be expanded to provide audio and data communication for 30 to over 1000 users.

The ACM Advanced Communication System provides a type-approved structured cabling system (CAT-6A) as the backbone. With its advanced wiring and patch solution, the system supports all-in-one cabling. This solution results in a significant reduction in cabling infrastructure where a single (CAT-6A) cable can provide telephony (analog or IP), General Alarm, Public Address, internet access, and IPTV to a cabin.

## Features

- Made for marine environment
- New modular building platform
- Advanced integration options
- Data network infrastructure
- Advanced cabling solution
- Integrated PA & GA distribution
- Wide range of audio terminals and signal units
- External communication and billing
- Remote management and maintenance using IP and Web technologies
- Redundant power input with switchover



# ACM Advanced System Racks



## Cabinets Indoor

Standard cabinets come in the most common sizes. All cabinets are assembled with fixed 19" frames and ready for Vingtor-Stentofon building modules. These cabinets are suitable for Marine applications. All cabinets include two grounding bars, a cable inlet at the bottom, a mounting base and a thermostat controlled ventilation fan in the steel door.

- Material Steel
- Color RAL 7035
- Floor mounted
- Cable inlet bottom (Cable inlet top available on request)

2810010051

**CAB24FW Pre-Assembled Cabinet**  
Floor 19" 24 HU 810x1350x680 mm,  
Fixed Frame, IP-22, Ventilation

2810010052

**CAB24FWD Pre-Assembled Cabinet**  
Floor 19" 24 HU 810x1350x880 mm,  
Fixed Frame, IP-22, Ventilation

2810010053

**CAB42F Pre-Assembled Cabinet**  
Floor 19" 42 HU 610x2165x630 mm,  
Fixed Frame, IP-22, Ventilation

2810010054

**CAB42FW Pre-Assembled Cabinet**  
Floor 19" 42 HU 810x2165x630 mm,  
Fixed Frame, IP-22, Ventilation

2810010055

**CAB42FWD Pre-Assembled Cabinet**  
Floor 19" 42 HU 810x2165x830 mm,  
Fixed Frame, IP-22, Ventilation

1159607200

### ACM-XE7 Module

- Max 36 traditional intercom
- Max 72 analog telephones
- Max 552 IP intercoms, IP telephones or IP DECT handsets
- Delivered with standard programming and documentation – programming and engineering for project customizing.
- Equipped with AlphaCom AMC-IP Board, 1009202000  
1009296100 STIC for XE1/ XE7



**Size (WxHxD): 427 x 133 x 380 mm Weight: 9.0 kg**

Additional Information: Assembly included  
Power supply 2990000033 CPM-SNT-250-10  
100-240VAC/24VDC 10A needed

1009627002

### XE20/XE26 High Availability Extension Package

- For upgrading of existing ACM-XE20 or ACM-XE26 to have redundant control cards
- 1009202100 AMC-IP Card
- 1009511000 AMC-IP filtercard and APC Upgrade Kit

1159620200

### ACM-XE20 Module

- Max 102 traditional intercoms
- Max 204 analog telephones
- Max 552 IP intercoms, IP telephones or IP DECT handsets
- Delivered with standard programming and documentation – see programming and engineering for project customizing.
- Equipped with:  
AlphaCom AMC-IP Board, 1009202000  
AlphaCom AMC-IP Filter Board, 100951100  
APC AlphaCom program & CLOCK, 1009301000  
AlphaCom Filter Board APC - FB, 1009503000  
Power supply 230 VAC -MK2, 1009703000  
Fan module, 1009296200 STIC for XE20 / XE26



**Size (WxHxD): 482 x 265 x 365 mm Weight: 19 kg**

Additional Information: Assembly included

1159626200

### ACM-XE26 Module

- Max 138 traditional intercoms
- Max 276 analog telephones
- Max 552 IP intercoms, IP telephones or IP DECT handsets
- Delivered with standard programming and documentation – see programming and engineering for project customizing.
- Equipped with:  
AlphaCom AMC-IP Board, 1009202000  
AlphaCom AMC-IP Filter Board, 100951100  
APC AlphaCom program & CLOCK, 1009301000  
AlphaCom Filter Board APC - FB, 1009503000  
2x Power supply 230 VAC -MK2, 1009703000  
Fan module, 1009296200 STIC for XE20 / XE26



**Size (WxHxD): 482 x 841 x 365 mm Weight: 39 kg**

Additional Information: Assembly included

## Analog Intercom Stations

1007034210

### VMP-619 Main Station, Ivory

- Combined wall and desk master station with full access to all features in the ACM exchange
- 10 direct access keys
- Superb audio quality
- Handset for confidential conversations
- Advanced supervision functions



**Size (WxHxD): 225 x 75 x 176 mm Weight: 0.670 kg**

Additional Information: Station accessory kit needed, see order no. 1009800100

1007072090

### VMP-D619B Main Station with Display, Black

- Typed approved for broadcasting public address and general alarm as well as two way communication
- Combined wall and desk master station with full access to all features in the ACM exchange
- Easy operation provided by a 2 x 16 character alphanumeric display and ten direct access keys
- Superb audio quality
- Handset for confidential conversations
- Advanced supervision functions
- Volume override
- Approved station for PA/GA



**Size (WxHxD): 225 x 75 x 176 mm Weight: 0.670 kg**

Additional Information: Station accessory kit needed, see order no. 1009800100

1020600315

### VMP-503 Main Station with Built-in 50-Ohm Loudspeaker

- Designed for use with ACM exchanges and for wall mounting.
- Handsfree open conversation or private when used with Handset VMP-211 or VMP-250.
- Built-in loudspeaker
- Built-in electret microphone gives clear sound
- Keyboard with large digits
- C-key for cancelling calls
- M-key for manual switching of speech direction (simplex).
- Voice operating duplex speech.
- Full duplex when connected with handset VMP-221
- Public Address messages via General Call and Group
- Calls with automatic answer back, are available
- Audio Programmes can individually be selected and received.
- Screw terminals for easy connection of Installation cables and optional



**Size (WxHxD): 124 x 224 x 63 mm Weight: 0.75 kg**

Additional Information: IP-65

1020600305 / 3006202035

### VMP-530 / VMP-530VHM Main Station

- Designed for humid, dirty and outdoor conditions, wall mounting
- Built-in microphone
- Need external loudspeaker VML-1520 (not included)
- Voice operated duplex, full duplex with handset VMP-211 or VMP-250
- VMP-530VHM : with Handheld Microphone in Watertight Cabinet



**Size (WxHxD) VMP-530: 124x224x63 mm Weight: 0.75 kg**

**Size (WxHxD) VMP-530VHM: 310x215x160 mm Weight: 4.5 kg**

Additional Information: IP-66

3006202031

### VMP-503PA Portable Main Station with Built-in Loudspeaker

- Designed for humid, dirty and outdoor conditions
- 5m cable, plug and carrying handle
- Built-in loudspeaker and microphone
- Voice operated duplex



**Size (WxHxD): 124 x 224 x 63 mm Weight: 1.03 kg**

Additional Information: IP-65  
3006202037 VMP-503PA/15 portable main station w/ built-in loudsp. W/ 15m cable, WT IP-65

1008114010

### TCAS-1 Turbine Compact

- Analog MEMS microphone
- Unique 3D speaker grille design
- Dirt, dust and water resistant - rating IP-66
- Built to last with robust die cast aluminium frame - rating IK 08
- Yellow thermoplastic front plate with one button plus M and C
- Ideal for Industrial applications



**Size (WxHxD): 120 x 180 x 54 mm Weight: 0,8 kg**

Accessories: 1008140010 TA-1 Turbine Compact On Wall Box IP-66



# ACM IP Intercom Stations



## IP Intercom Stations for Bridge & ECR

Vingtor-Stentofon offers a comprehensive range of IP intercom indoor solutions. IP intercom stations offer benefits such as minimal installation requirements, remote software upgrades and Power over Ethernet (PoE), among others.

1008097100

### CRM-V-HS Handset for CRM-V

- Handset module for IP Flush Master



Size (WxHxD): 67 x 280 x 41 mm Weight: 0.4 kg

Additional Information: For 1008031000 IP Flush master

1008031000

### CRM-V IP Flush Master, Display

- Made for Critical Communication over IP
- Connects directly to the IP network, no geographical limitations
- Large high contrast display with backlight for excellent readability
- White light behind all keys
- Four freely programmable single-touch keys (DAK)
- Superb audio technology
- Optional handset unit
- Remote upgrade, configuration and monitoring
- Internal relay output



Size (WxHxD): 125 x 280 x 30 mm Weight: 0.37 kg

Additional information: 1008097500 Gooseneck Microphone, 1008097100 Handset Require IP station license

2213100000

### CRM-VH Headset Solution for CRM-V

- Headset solution for IP Flush Master
- Includes ON/OFF switch
- Flush mounting
- Light, comfortable, single-sided mono headset
- Noise cancelling microphone



Size (WxHxD): 96 x 96 x 80 mm Weight: 0.24 kg

Additional Information: IP-21  
Disclaimer: Only for included headset

1008010100

### CRM-V-DAK48 DAK Key Expansion Module for CRM-V

- Extends IP Flush Master Station with 48 programmable DAK keys (direct access keys)
- Ideal for PA, talk-back and telephone calls
- Visual indications with two LEDs (green/red) per DAK key
- All keys have backlight (adjustable)
- Easy labelling of keys



Size (WxHxD): 125 x 280 x 30 mm Weight: 0.65 kg

Additional Information: For 1008031000 IP Flush master  
Require CRM license

1008001000

### IP Desk Master Station with Display & Handset

- Large high contrast display with backlight for excellent readability
- Four dynamic menu navigation keys
- Supports broadcast of general alarm and public address functions
- Supports wide set of features such as group call, conference call, call queuing
- Ten DAK keys provide single-touch access functions
- Handset for confidential conversations
- Superb audio quality through wide bandwidth codec and high quality, high output power amplifier
- Integrated Web server
- Remote software upgrade, configuration and monitoring
- Full duplex functionality gives optimal speech quality in loudspeaker mode



Size (WxHxD): 225 x 75 x 176 mm Weight: 0.630 kg

Additional Information: Require IP station license  
Wall bracket 1008091100

149000010

### SDS-1 IP SIP Desk Station

- 2 lines, 2 SIP accounts, 3-way conferencing
- Integrated PoE
- Dual-switched 10/100 Mbps ports
- TLS and SRTP
- HD Audio
- EHS Support
- AlphaCom XE Support



Size (WxHxD): 184.5 x 209 x 76.2 mm Wt: 0.73 kg

1490001010

### ITSV-1 IP Touch Video Station

- Video desktop intercom station
- Phonebook with up to 1000 contacts and call history with up to 1000 records
- Dual switched auto-sensing 10/100/1000Mbps network ports
- Wi-Fi (802.11b/g/n), PoE+, Bluetooth, USB, SD, HDMI, EHS with Plantronics headsets support
- 4.3" (480x272) capacitive (5 points) touch screen TFT LCD
- Megapixel CMOS sensor camera with privacy shutter
- HD wideband audio
- Full-duplex hands-free speakerphone with advanced acoustic echo cancellation and excellent double-talk performance
- Not type-approved



Size (WxHxD): 196.5 x 206.2 x 85.2 mm Wt: 0.92 kg

1023200033

### ECPIR-3P Indoor Intercom

- Indoor intercom for console mounting
- Communication and Power over Ethernet
- Three programmable buttons with individual labels and status indicators
- Separate PTT button
- Optional button protection covers
- Indicators for power, call and fault
- Can be used with handheld or gooseneck mic
- Background Noise Cancellation
- IP Rating: IP32



Size (WxHxD): 96 x 144 x 50 mm Weight: 0.5 kg

Accessories: 1023253008 EBMDR-8 Button Expansion Module, 1023533011 EMMAR-1H Handheld Mic, 3005020033 MB-30G Gooseneck Mic

1023253008

### EBMDR-8 Expansion Module

- Button expansion module for console mounted ECPIR-3P intercom
- Powered from master access panel
- Eight programmable buttons with individual labels and status indicators
- Optional button protection covers
- Four units can be connected to one intercom



Size (WxHxD): 96 x 144 x 50 mm Weight: 0.5 kg

IP Rating: IP-32

1023533012

### PAM1H Mic for ECPIR-3P

- Handheld PA microphone with bracket
- For indoor use
- Push-To-Talk button
- Electret and Noise Cancelling microphone



Size: Length 142 mm, Head Ø 29 mm, Body Ø 24 mm

Weight: 0.19 kg  
Cord length: 1.5 m

Additional Information: IP-66

1008116010

### TMIS-1 Turbine Mini

- Background Noise Cancellation
- Built to last with robust die-cast aluminum frame
- White thermoplastic front plate with one button



Size (WxHxD): 116 x 116 x 40 mm Wt: 0.3 kg

1008116020

### TMIS-2 Turbine Mini

- Background Noise Cancellation
- Vandal Resistant Design
- 11 Gauge Stainless Steel Faceplate



Size (WxHxD): 114 x 114 x 55 mm Wt: 0.5 kg

## Industrial IP Stations

1008111010

### TCIS-1-Turbine IP Station

- Amazing sound pressure level when needed
- Background noise cancellation
- Dirt, dust and water resistant - Class IP 66
- Built to last with robust die-cast aluminum frame - Class IK 08
- Support wide set of IP and networking standards
- Yellow thermoplastic front plate with one button + M and C
- Buttons with background light



**Size (WxHxD): 120 x 180 x 70 mm Weight: 0.8 kg**

Accessories: 1008140010 TA-1 Turbine Compact On Wall Box, 1008140020 TA-2 Turbine Compact Flush Back Box, 1008140140 TA-14 Microphone Windscreen for TCIS/TCIV

1008111050

### TCIS-5 Turbine IP Station

- Amazing sound pressure level when needed
- Background noise cancellation
- Dirt, dust and water resistant - IP66 rating
- Built to last with robust die-cast aluminum frame - IK08 rating
- Designed according to the norm for hearing impaired
- Support wide set of IP and networking standards
- Black thermoplastic front plate with two labelled buttons
- Unique labeling solution with PMOLED display
- Ideal for Building Security and Public Environments



**Size (WxHxD): 120 x 180 x 70mm Wt: 0.8kg**

Accessories: 1008140010 TA-1 Turbine Compact On Wall Box, 1008140020 TA-2 Turbine Compact Flush Back Box, 1008140140 TA-14 Microphone Windscreen for TCIS/TCIV

1008111060

### TCIS-6 Turbine IP Station

- Amazing sound pressure level when needed
- Background noise cancellation
- Dirt, dust and water resistant - Class IP 66
- Built to last with robust die-cast aluminum frame - Class IK 08
- Support wide set of IP and networking standards
- Black thermoplastic front plate with scrolling unit for calling to an unlimited number of places
- PMOLED display



**Size (WxHxD): 120 x 180 x 70 mm Weight: 0.8 kg**

Accessories: 1008140010 TA-1 Turbine Compact On Wall Box, 1008140020 TA-2 Turbine Compact Flush Back Box, 1008140140 TA-14 Microphone Windscreen for TCIS/TCIV

1008115020

### TCIV-2 Video Station

- HD Video at up to 25 FPS (720p)
- Wide angle lens (90°)
- MJPEG and H.264 for integration with most Video solutions
- Designed according to Disability Act requirements
- Background noise cancellation
- Dirt, dust and water resistant - IP66 rating
- Built to last with robust die-cast aluminum frame
- Supports wide set of IP and networking standards
- Stainless steel front plate with one button
- Ideal for Building Security and Public Environments
- Background Noise Cancellation
- Not type-approved
- ONVIF Profile S conformant



**Size (WxHxD): 120 x 180 x 70mm Wt: 0.8kg**

Accessories: 1008140010 TA-1 Turbine Compact On Wall Box, 1008140020 TA-2 Turbine Compact Flush Back Box, 1008140140 TA-14 Microphone Windscreen for TCIS/TCIV

1008115030

### TCIV-3 Video Station

- HD Video at up to 25 FPS (720p)
- Wide angle lens (90°)
- MJPEG and H.264 for integration with most Video solutions
- Designed according to Disability Act requirements
- Background noise cancellation
- Dirt, dust and water resistant - IP66 rating
- Built to last with robust die-cast aluminum frame
- Supports wide set of IP and networking standards
- Black thermoplastic front plate with one button
- Ideal for Building Security and Public Environments
- Background Noise Cancellation
- Not type-approved
- ONVIF Profile S conformant



**Size (WxHxD): 120 x 180 x 70mm Wt: 0.8kg**

Accessories: 1008140010 TA-1 Turbine Compact On Wall Box, 1008140020 TA-2 Turbine Compact Flush Back Box, 1008140140 TA-14 Microphone Windscreen for TCIS/TCIV

1008115060

### TCIV-6 Video Station

- HD Video at up to 25 FPS (720p)
- Wide angle lens (90°)
- MJPEG and H.264 for integration with most Video solutions
- Designed according to Disability Act requirements
- Background noise cancellation
- Dirt, dust and water resistant - IP66 rating
- Built to last with robust die-cast aluminum frame
- Supports wide set of IP and networking standards
- Black thermoplastic front plate with scrolling unit
- PMOLED display
- Ideal for Building Security
- Background Noise Cancellation
- Not type-approved
- ONVIF Profile S conformant



**Size (WxHxD): 120 x 180 x 70mm Wt: 0.8kg**

Accessories: 1008140010 TA-1 Turbine Compact On Wall Box, 1008140020 TA-2 Turbine Compact Flush Back Box, 1008140140 TA-14 Microphone Windscreen for TCIS/TCIV

1008122010

### TFIE-1 Turbine Industrial IP station

- IP intercom for industrial environments
- Dual Ethernet connectivity for redundant networks
- PoE powered
- Auxiliary DC power for redundancy
- DIP functionality for use with AlphaCom servers
- SIP/VoIP functionality for use with 3rd-party systems
- Dual relay outputs
- 6 configurable I/Os
- Dust- and water-protected to IP-66
- Accessories include Handheld PTT, Headset with ON/OFF and PTT and Handset with PTT
- Monitoring and self-diagnostics of critical functionality
- Visible status indicators on front panel
- Background Noise Cancellation



Size (WxHxD): 178 x 345 x 101 mm Weight: 1.9 kg

Accessories: 1023533311 EMMAI-1H Mic, 1023533312 EMMAI-2H Mic, 1008140230 TA-23 Handset, AK5850HS Headset, 1008140225 TA-22B Cable & Plugbox, 1008140100 TA-10 Relay Module

## Industrial Station Accessories

AK5850HS

### A-Kabel TwinCom Headband Headset ATEX

- Rugged headset for Industrial application
- Noise-cancelling microphone
- High quality digital background noise reduction
- HD-voice compatible
- High quality audio
- Standard 4-pole Nexus connector for easy connection/replacement
- Designed for Turbine Industrial & Ex Intercoms



Weight: 0.4 kg

Additional Information: IP-66  
1008140225 TA-22b 10m Cable and Plugbox with PTT for Industrial Headset

1008122020

### TFIE-2 Turbine Industrial IP station

- IP intercom for industrial environments
- Dual Ethernet connectivity for redundant networks
- PoE powered
- Auxiliary DC power for redundancy
- DIP functionality for use with AlphaCom servers
- SIP/VoIP functionality for use with 3rd-party systems
- Dual relay outputs
- 6 configurable I/Os
- Dust- and water-protected to IP-66
- Accessories include Handheld PTT, Headset with ON/OFF and PTT and Handset with PTT
- Monitoring and self-diagnostics of critical functionality
- Visible status indicators on front panel
- Background Noise Cancellation



Size (WxHxD): 178 x 345 x 101 mm Weight: 1.9 kg

Accessories: 1023533311 EMMAI-1H Mic, 1023533312 EMMAI-2H Mic, 1008140230 TA-23 Handset, AK5850HS Headset, 1008140225 TA-22B Cable & Plugbox, 1008140100 TA-10 Relay Module

1023533312

### EMMAI-2H Industrial Mic

- PTT key on handset
- Noise cancelling microphone
- High quality digital background noise reduction
- HD voice compatible
- Designed for Turbine Industrial intercom stations



Size (WxHxD): 44 x 68 x 21.5 mm Weight: 0.22 kg

Additional Information: IP-66  
Wallbracket included

1008140225

### TA-22b Cable & Plugbox

- 10-meter cable
- Compact, rugged plugbox with PTT
- Designed for Turbine Industrial Intercoms



Weight: 0.4 kg

Additional Information: IP-66  
For 1008140220 TA-22 Industrial Headset for Turbine - pluggable

1008122060

### TFIE-6 Turbine Industrial IP station

- IP intercom for industrial environments
- Dual Ethernet connectivity for redundant networks
- PoE powered
- Auxiliary DC power for redundancy
- DIP functionality for use with AlphaCom servers
- SIP/VoIP functionality for 3rd-party systems
- Dual relay outputs
- Full Keypad + 6 configurable I/Os
- Dust- and water-protected to IP-66
- Accessories include Handheld PTT, Headset with ON/OFF and PTT and Handset with PTT
- Monitoring and self-diagnostics of critical functionality
- Visible status indicators on front panel
- PMOLED display with scrolling unit for calling to unlimited number of places



Size (WxHxD): 178 x 345 x 101 mm Weight: 1.9 kg

Accessories: 1023533311 EMMAI-1H Mic, 1023533312 EMMAI-2H Mic, 1008140230 TA-23 Handset, AK5850HS Headset, 1008140225 TA-22B Cable & Plugbox, 1008140100 TA-10 Relay Module

1008140230

### TA-23 Industrial Handset

- Rugged handset for Industrial application
- PTT-key for operation in noisy environments
- Noise-cancelling microphone
- High quality digital background noise reduction
- HD-voice compatible



Size (WxHxD): 50 x 200 x 70 mm Weight: 0.310 kg

Additional Information: IP-66

1008140100

### TA-10 Relay Module

- Designed for use with Turbine Industrial stations
- Powered by Turbine Industrial stations (TFIE-x)



Size (WxHxD): 100 x 50 x 40 mm Wt: 0.1 kg

Related items: 1008122010 TFIE-1, 1008122020 TFIE-2, 1008122060 TFIE-6, 1008132010 TKIE-1

## Ex Proof Stations & Accessories

1008123010

### TFIX-1 Turbine Ex Station

- Ex IP intercom for potentially explosive atmospheres - Directive 94/9/EC
- Ethernet compatible 2-wire interface
- DIP functionality for AlphaCom audio servers
- SIP/VoIP functionality for 3rd-party systems
- Dust- and water-protected to IP-66
- Monitoring and self-diagnostics of critical functionality
- Visible status indicators on front panel
- Background Noise Cancellation



**Size (WxHxD): 178 x 345 x 101 mm Weight: 4 kg**

Accessories: 1023533511 EMMAX-1H Mic, 1008150030 TAX-3 Handset, AK5850HS Headset, 1008150025 TAX-2B Cable & Plugbox

1008123040

### TFIX-4 Turbine Ex Station

- Ex IP intercom for potentially explosive atmospheres - Directive 94/9/EC
- Ethernet compatible 2-wire interface
- DIP functionality for use with AlphaCom audio servers
- SIP/VoIP functionality for use with 3rd-party systems
- Dust- and water-protected to IP-66
- Monitoring and self-diagnostics of critical functionality
- Visible status indicators on front panel
- Background Noise Cancellation



**Size (WxHxD): 178 x 345 x 101 mm Weight: 4 kg**

Accessories: 1023533511 EMMAX-1H Mic, 1008150030 TAX-3 Handset, AK5850HS Headset, 1008150025 TAX-2B Cable & Plugbox

1008123020

### TFIX-2 Turbine Ex Station

- Ex IP intercom for potentially explosive atmospheres - Directive 94/9/EC
- Ethernet compatible 2-wire interface
- DIP functionality for use with AlphaCom audio servers
- SIP/VoIP functionality for use with 3rd-party systems
- Dust- and water-protected to IP-66
- Monitoring and self-diagnostics of critical functionality
- Visible status indicators on front panel
- Background Noise Cancellation



**Size (WxHxD): 178 x 345 x 101 mm Weight: 4 kg**

Accessories: 1023533511 EMMAX-1H Mic, 1008150030 TAX-3 Handset, AK5850HS Headset, 1008150025 TAX-2B Cable & Plugbox

1008150030

### TAX-3 Handset with PTT

- Rugged handset for Ex application
- PTT-key for operation in noisy environments
- Noise-cancelling microphone
- High quality digital background noise reduction
- HD-voice compatible
- IP Rating: IP66



**Size (WxHxD): 200 x 70 x 50 mm Weight: 310 g**

1023533511

### EMMAX-1H Handheld Microphone

- Handheld mic with PTT key for Ex applications
- Curled cord
- Noise cancelling microphone
- High quality digital background noise reduction
- HD voice compatible



**Size (WxHxD): 44 x 68 x 21.5 mm Weight: 0.22 kg**

Additional Information: IP-66  
Wall bracket included

1008123030

### TFIX-3 Turbine Ex Station

- Ex IP intercom for potentially explosive atmospheres - Directive 94/9/EC
- Ethernet compatible 2-wire interface
- DIP functionality for use with AlphaCom audio servers
- SIP/VoIP functionality for use with 3rd-party systems
- Dust- and water-protected to IP-66
- Monitoring and self-diagnostics of critical functionality
- Visible status indicators on front panel
- Background Noise Cancellation



**Size (WxHxD): 178 x 345 x 101 mm Weight: 4 kg**

Accessories: 1023533511 EMMAX-1H Mic, 1008150030 TAX-3 Handset, AK5850HS Headset, 1008150025 TAX-2B Cable & Plugbox

AK5850HS / 1008150025

### Ex-Proof Headset TAX-2b 10m Cable & Plugbox

- Rugged headset for Ex application
- Noise-cancelling microphone
- High quality digital background noise reduction
- HD-voice compatible
- High quality audio
- Optional in-ear monitors may be connected for added damping in extreme environments
- IP Rating: IP-66
- Standard 4-pole Nexus connector for easy connection/replacement
- Designed for Turbine Ex explosion-proof intercoms
- AK5850HS: Ex-Proof Headset
- 1008150025: TAX-2B Cable & Plugbox



**Weight: 0.4 kg**

Additional Information: IP-66  
1008150025 TAX-2b 10m Cable and Plugbox with PTT for AK5850HS



# INTEGRATED COMMUNICATION SYSTEM: PHONTECH ICS 6200

The ICS 6200 Integrated Communication System is a digital communication system meeting all aspects of internal & external communication, and information exchange onboard marine vessels, offshore installations and to/from onshore operation centers.



OFFICER CABINS / OFFICES  
6210 TELEPHONE, DESKTOP / WALL, UpN, IP22  
7210 TELEPHONE, DESKTOP / WALL, VoIP, IP22



CABINS / ACCOMMODATION  
GIGASET DA-710



ENGINE ROOM  
6211 TELEPHONE, INDUSTRIAL, UpN, IP56  
7211 TELEPHONE, INDUSTRIAL VoIP, IP56



ADDITIONAL FEATURES:

- MPA OPTION
- VARIOUS LOUDSPEAKERS

ADDITIONAL FEATURES:

- IP CAMERAS
- IP BRIDGES
- SATCOM INTERFACE
- CELL PHONE INTERFACE



INSTRUMENT ROOM  
9U PHONTECH SYSTEM CABINET



ENGINE ROOM  
HEADSET FOR 6212 AND 7212



BRIDGE / ENGINE CONTROL ROOM  
6223 TELEPHONE, CONSOLE, UpN, IP22  
7223 TELEPHONE, CONSOLE, VoIP, IP22

WORKSHOP  
6212 TELEPHONE, INDUSTRIAL, WITHOUT HANDSET, UPN, IP56  
7212 TELEPHONE, INDUSTRIAL, WITHOUT HANDSET, VOIP, IP56



BRIDGE / ENGINE CONTROL ROOM  
6216 EMERGENCY PA UNIT



ICS 6200 is type approved according to RMRS and DNV.



Item No. 40000100279C

### Compact ICS Integrated System

- Integrated Communication System designed for internal/external 2-way communication.
- The system is optimized for IMO/Solas requirements on both small and medium sized marine vessels.
- IP-22 Rating
- Capacity: 72 lines or 24 Lines + 24 VoIP
- Dual power supply: AC/DC or AC/AC



Size (WxHxD): 618x585x470 mm Wt: 30 kg

Item No. 4000018934ICS

### ICS System Cabinet 9U

- IP-20 Rating
- Flexible and configurable 9U cabinet



Size (WxHxD): 456x553x600 mm Wt: 50 kg

Item No. 4000018935ICS

### ICS System Cabinet 16U

- IP-20 Rating
- Flexible and configurable 16U cabinet



Size (WxHxD): 553x767x600 mm Wt: 75 kg

Item No. 40000100040

### P-6216 Emergency PA Unit

- Noise cancelling microphone
- Emergency PA button with a protective cover for protection against unintended activation.



Size (WxHxD): 120x80x70 mm Wt: 0.3 kg

Item No. 4000017923C

### P-6200 ICS 6200 Central Unit

- 24 lines
- 48 VoIP registrations
- Power: 220/110VAC/48/24VDC
- Power dissipation: 60W



Size: 19" 1U Wt: 3.5 kg

Item No. 4000019327

### P-6202 Billing Unit

- Call meta data logging for all calls made in a Phontech 6200 system
- Calculation of billing invoices for users of the system
- Pre-paid or post-call payment
- Password protected web interface management for printing reports, viewing call logs and managing account balances
- Call restrictions based on available account balances



Size: 19" 1U Wt: 3.5 kg

Item No. 4000018936ICS/4000018937ICS

### ICS System Cabinet 25U/34U

- IP-20 Rating
- Flexible and configurable 25U/34U cabinet
- Color: Black RAL 7021

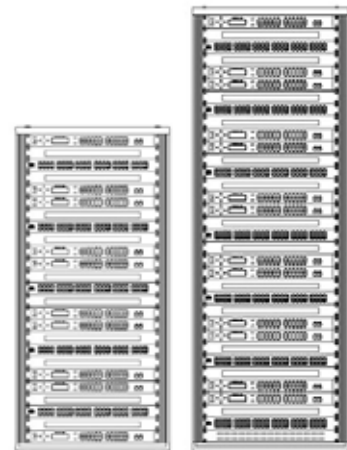

Size (WxHxD): 553x1167/1567x600 mm Wt: 50-150 kg



Item No. 4000018933

### P-6110 MkII Indoor Telephone

- Table or Wall Mounted
- Loudspeaking / handset operation
- Memory buttons



Size (WxHxD): 175x230x80 mm Wt: 0.9 kg

Item No. 40000200100

### P-6210 Telephone

- Table or Wall Mounted
- Integrated loudspeaker/microphone
- Handset, 2 meter sturdy curled cord
- Hands-free, duplex communication
- 2" Graphic backlit display:
- Dimmable backlight (keypad)
- Privacy switch with priority override
- Manual PTT (push-to-talk) key
- 3 pcs programmable direct access keys (A-B-C)
- Volume adjustment with override
- Bulkhead mounted
- Status/health indicator
- Multiple ring melodies
- Integrated call relay for external signal Device
- Headset connection



Size (WxHxD): 175x230x80 mm Wt: 0.9 kg

Item No. 40000200300

### P-6211 Telephone, Industrial

- Bulkhead Mounted
- Integrated loudspeaker/microphone
- Handset, 2 meter sturdy curled cord
- Hands-free, duplex communication
- 2" Graphic backlit display:
- Dimmable backlight (keypad)
- Privacy switch with priority override
- Manual PTT (push-to-talk) key
- 3 pcs programmable direct access keys (A-B-C)
- Volume adjustment with override
- Bulkhead mounted
- Status/health indicator
- Multiple ring melodies
- Integrated call relay for external signal Device
- Headset connection



Size (WxHxD): 175x230x80 mm Wt: 0.9 kg

Item No. 40000200500

### P-6212 Telephone, Industrial

- Table or Wall Mounted
- Integrated loudspeaker/microphone
- Hands-free, duplex communication
- 2" Graphic backlit display:
- Dimmable backlight (keypad)
- Privacy switch with priority override
- Manual PTT (push-to-talk) key
- 3 pcs programmable direct access keys (A-B-C)
- Volume adjustment with override
- Bulkhead mounted
- Status/health indicator
- Multiple ring melodies
- Integrated call relay for external signal Device
- Headset connection



Size (WxHxD): 175x230x80 mm Wt: 0.9 kg

Item No. 40000200700

### P-6223 Telephone, Console

- Console Mounted
- Integrated loudspeaker/microphone
- Handset, 2 meter sturdy curled cord
- Hands-free, duplex communication
- 2" Graphic backlit display:
- Dimmable backlight (keypad)
- Privacy switch with priority override
- Manual PTT (push-to-talk) key
- 3 pcs programmable direct access keys (A-B-C)
- Volume adjustment with override
- Bulkhead mounted
- Status/health indicator
- Multiple ring melodies
- Integrated call relay for external signal Device
- Headset connection



Size (WxHxD): 175x230x80 mm Wt: 0.9 kg

4000019031

### DA710 Gigaset Analog Telephone

- Handsfree corded phone with phonebook
- 100 phonebook entries
- Hinged alphanumerical display
- Caller identification
- 8 direct dialing keys with 2 layers



Size (WxHxD): 192x300x121.5 mm Weight: 1.5 kg

4000017151

### P-5113 Telephone with Relay

- DTMF analog telephone
- Loudspeaking / handset operation
- Memory buttons
- Built-in relay, max 5A
- External loudspeaker connection
- IEC 60945 Marine equipment
- The unit has a DNV type approval and is also compatible with NORSOK



Size (WxHxD): 192x240x121.5 mm Weight: 1.2 kg

Additional Information:IP-22

4000017150

### P-5123 Telephone with Relay

- DTMF analog telephone
- Loudspeaking / handset operation
- Memory buttons
- Built-in relay, max 5A
- External loudspeaker connection
- IEC 60945 Marine equipment
- The unit has DNV/ABS/RMRS/CCS/RINA type approvals and is also compatible with NORSOK



Size (WxHxD): 192x240x121.5 mm Weight: 1.2 kg

Additional Information:IP-22

4000016715

### P-5111 Desk Mount Telephone

- Watertight IP-65
- Strong call tone  $\geq 95$ db (A), 1m
- Shock resistant housing
- IEC 60945 Marine equipment
- The unit has a DNV-GL type approval



Size (WxHxD): 191x317x128 mm Weight: 2.3 kg

4000016759

### P-5111H Telephone for Headset

- Equipped with headset interface for use in noisy environments
- IEC 60945 Marine equipment
- The unit has a DNV-GL type approval
- Headset interface
- Watertight
- Strong call tone  $\geq 95$ db (A), 1m
- Shock resistant housing
- IP-65



Size (WxHxD): 191x317x128 mm Weight: 2.4 kg

4000014774

### P-6035/10 Headset, 10-Meter Cable

- Quick positioning noise-cancelling boom microphone
- Equipped with an ON/OFF hook switch.
- Complies with IEC 60945 Marine equipment.
- The unit has DNV-GL, ABS, CCS and RMRS type approval
- PPE directive 89/686/EEC
- Applicable parts of EN352-1:1993
- Excellent noise-cancelling
- High attenuating ear shells
- IP-54



Size (HxD): 200x95 mm Weight: 0.7 kg

2212000101

### DT-800M Desktop Analog Telephone

- Solid construction for marine environment
- Desk or wall mounting
- Good audio quality
- Full keyboard (including R/flash key)
- Easy to use with large buttons and special function keys for Redial and Mute
- Suitable for cabins and offices



Size (WxHxD): 162 x 79 x 193 mm Weight: 0.4 kg

Additional Information: IP-20

2213000100

### KNSP-09 Heavy Duty Analog Telephone

- 5 mm aluminium casing
- External ringer unit recommended such as HB-105 or CRB-7 with signal light
- Powered by phone line
- Full phone keypad plus special function keys



**Size (WxHxD): 205 x 320 x 120 mm Weight: 5kg**

Additional Information: IP-66  
Optional Junction box JB-15T O.no.3006090476

2213000200

### KNSP-01 Heavy Duty Analog Telephone with Door

- 5 mm aluminium casing
- External ringer unit recommended such as HB-105 or CRB-7 with signal light
- Door has smart stay-open or stay-shut mechanism



**Size (WxHxD): 205 x 320 x 120 mm Weight: 5.4 kg**

Additional Information: IP-67  
Optional Junction box JB-15T O.no.3006090476

3005000025

### HSB-03 Telephone Wall with Headset Plug, Active, On/Off

- Weatherproof multipurpose telephone
- To be used in combination with headset P-MT7 or handset HAS-3
- Alarm bell HB-105 can be connected direct
- One relay (max 50 mA)
- Protection IP-66



**Size (WxHxD): 124 x 724 x 63 mm Weight: 0.6 kg**

Accessories :  
3005020050 P-MT7 Headset w/Boom Mic, 10M Cord  
3005000022 HAS-3 Handset w/C16 Plug

2213001002 / 2213001003

### DA24 / DA24H Ex Telephone

- Analog industrial Ex Telephone for Zone 1
- The telephone set has an extremely robust keypad with 16 push buttons
- Can use both DTMF and pulse dialling
- The handset has an adjustable locking hook
- Ex II 2G EEx m ib e (ib) IIC T6 -20° C ≤ Ta ≤ 40 °C,  
Ex II 2D EEx m ib e (ib) IIC T4 -20° C ≤ Ta ≤ 60 °C
- DA24H : with Headset



**Size DA24H (WxHxD): 154 x 221 x 105 mm Weight: 1.9 kg / with headset: 2.23 kg**

Additional Information: Protection IP-66

# Special Communications Equipment

<b><u>Phontech 8300 MkII Sound Reception System</u></b>	<b><u>41</u></b>
<b><u>Phontech CIS 3000 Talk-Back System</u></b>	<b><u>43</u></b>
<b><u>Phontech ITCS Refrigerator &amp; Hospital Alarm System</u></b>	<b><u>48</u></b>
<b><u>VSP Batteryless Telephone System</u></b>	<b><u>51</u></b>
<b><u>12-Way Telephone System</u></b>	<b><u>53</u></b>
<b><u>20-Way Telephone System</u></b>	<b><u>54</u></b>
<b><u>VSP Intrinsically Safe Set for Ex Units</u></b>	<b><u>55</u></b>

# SOUND RECEPTION SYSTEM PHONTECH 8300 MKII

The sound reception system Phontech 8300 MkII is an acoustic electronic navigation aid designed to receive and detect foghorn sounds from other vessels. Phontech 8300 MkII is made for use onboard one-man operated closed bridge class ships.

OPTIONAL  
SLAVE UNITS



PHONTECH 8300 MkII  
BRIDGE



PHONTECH 8301 MKII  
MAST TOP



- IEC61162-450
- FAULT REPORTING AND EVENT LOGGING
  - VDR INTERFACE

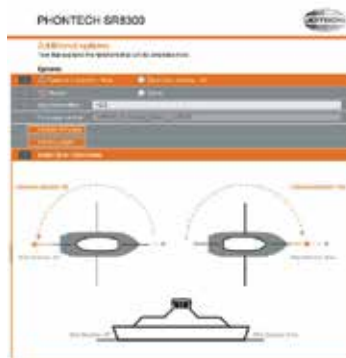

WEB INTERFACE

Phontech 8300 MkII is type approved by the MED, CCS, ABS, DNV and RMRS classification societies.



Item No. 4000019415

### P-8300 MkII Sound Reception Display Unit

- Sound Reception Main Unit - Console Mounted
- IP-22 Rating
- Flush / Console (optional wall mounting box)
- Functionality according to ISO 14859
- Sound capacity: 70 – 2100 Hz
- Power 21 – 32V DC
- Power consumption 8W (max)



Size (WxHxD): 144x144x124 mm Wt: 0.85 kg

Item No. 4000019416

### P-8301 MkII Sound Reception Microphone/Antenna

- IP-56 Rating
- Temperature: -25° to +55°C
- Vertical / Horizontal mounting
- Sound capacity: 70 – 2100 Hz
- Power (supplied from 8300 MkII, Display unit)



Size (WxHxD): 317x338 mm Wt: 3.95 kg

Item No.

### Junction Box for P-8301

- 12 terminals with cable screen
- IP-67 Rating
- Termination: Wago 264 terminal / earth plate / 2.5 mm<sup>2</sup> / 600V
- Max./min. amb. temp.: 90 °C / -50 °C



Wt: 0.35 kg



# TALK-BACK SYSTEM PHONTECH CIS 3000

The CIS 3000 Talk-Back System consists of a line of different master stations: Type 3100 (5 ext.), type 3101 (10 ext.), type 102 (20 ext.), and the extended facility units 3130/3131/3132 (15 ext. + 4 remote). The compact design is made according to DIN 144 standard sizes, harmonizing with our other models for console mounting. All master stations have a black keypad with integrated operator switches, indicator LEDs, loudspeaker, microphone and volume control. The operation is simplex, controlled by the master station with priority.

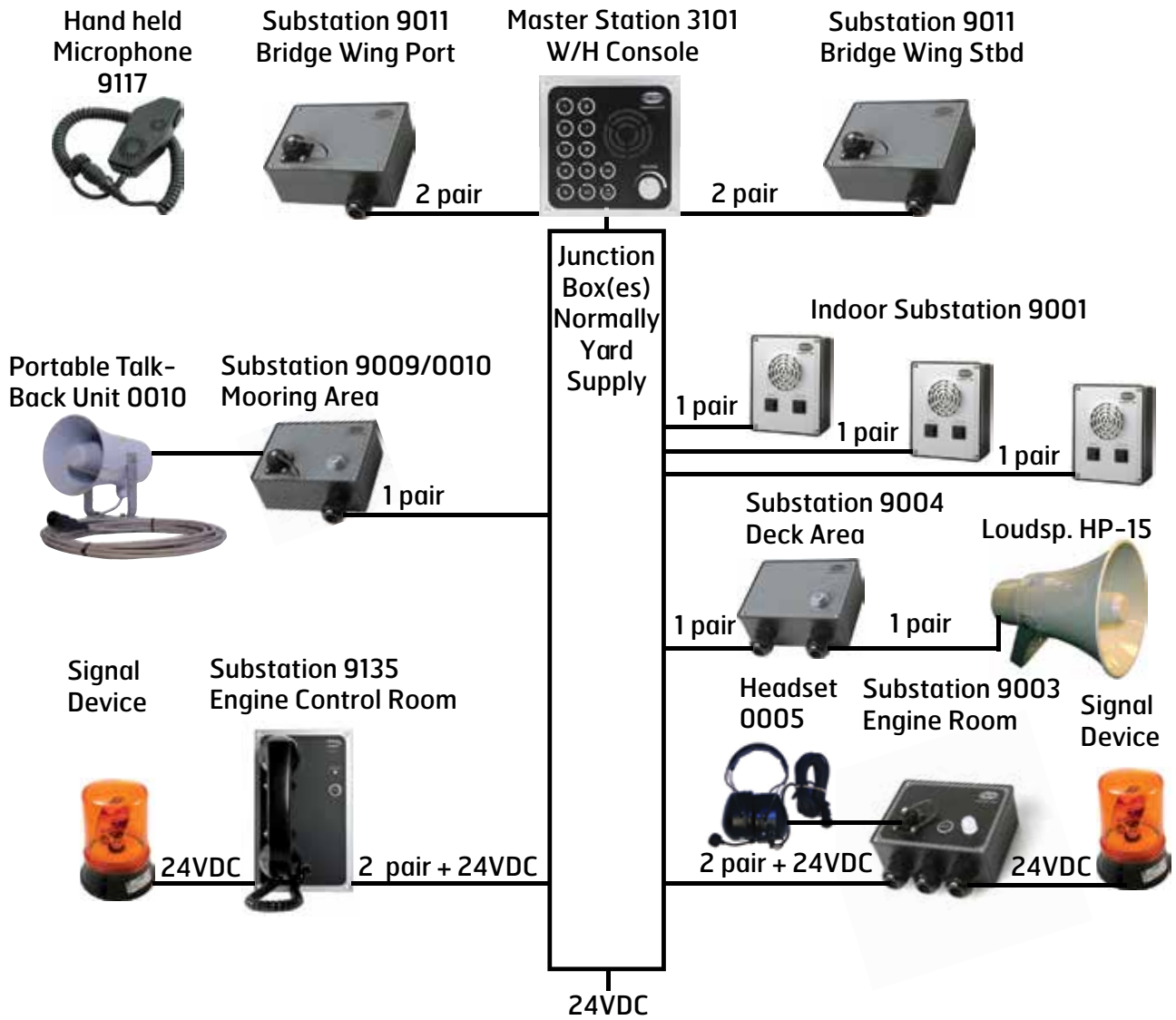

Item No. 4000016771

### P-3100 CIS Master Station 5 Lines

- Console Mounted, 24V DC, 5 Lines
- Bridge wings extension
- All-call audio input (0dBm/5mV)
- Integrated loudspeaker
- Integrated separate microphone
- Volume control in front
- All-call facility
- "Signal" and "Talk" keys
- Extra signal output lines 1-4
- Connection for gooseneck or handheld microphone
- Connection for extra loudspeaker



Size (WxHxD): 144x144x100 mm Wt: 0.85 kg

Item No. 4000016774

### P-3101 CIS Master Station - 10 Lines

- Console Mounted, 24V DC, 10 Lines
- Bridge wings extension
- All-call audio input (0dBm/5mV)
- Integrated loudspeaker
- Integrated separate microphone
- Volume control in front
- All-call facility
- "Signal" and "Talk" keys
- Extra signal output lines 1-4
- Connection for gooseneck or handheld microphone
- Connection for extra loudspeaker



Size (WxHxD): 144x144x100 mm Wt: 0.9 kg

Item No. 4000016785

### P-3102 CIS Master Station - 20 Lines

- Console Mounted, 24V DC, 10 Lines
- Bridge wings extension
- All-call audio input (0dBm/5mV)
- Integrated loudspeaker
- Integrated separate microphone
- Volume control in front
- All-call facility
- "Signal" and "Talk" keys
- Extra signal output lines 1-4
- Connection for gooseneck or handheld microphone
- Connection for extra loudspeaker



Size (WxHxD): 144x192x100 mm Wt: 1.15 kg

Item No. 4000016791

### P-3130 CIS Master Station - 15 Lines, 4 Remote Lines

- Connection for 15 substation lines
- Connection for 4 remote stations
- Control of 4 Public Address System zones
- Integrated loudspeaker
- Built-in condenser microphone
- Automatic gain control for speech level
- Loudspeaker volume control
- Tri-colored key indicator LEDs
- Automatic all call function
- Extra signal organ output for line 1-8
- External loudspeaker output connection
- Output for external signal device, own unit



Size (WxHxD): 144x192x100 mm Wt: 1.25 kg

Item No. 4000016789

### P-3131 CIS Master Station - 15 Lines, 4 Remote Lines, IP-55

- Bridge wings extension
- Integrated separate microphone
- Volume control built-in
- Connection for goose neck or handheld microphone
- Connection for external loudspeaker
- Flush or bulkhead mounting
- Integrated mic
- 24 VDC
- Total 30 W output



Size (WxHxD): 150x200x78 mm Wt: 0.75 kg

Item No. 4000016787

### P-3132 CIS Remote Master Station - 15 Lines, 4 Remote Lines

- Bridge wings extension
- Integrated loudspeaker
- Integrated separate microphone
- Volume control built-in
- Connection for goose neck or handheld microphone
- Connection for external loudspeaker
- Flush or bulkhead mounting
- Integrated mic
- 24 VDC
- Total 30 W output



Size (WxHxD): 144x192x100 mm Wt: 1.1 kg

Item No. 4000017570

### P-9001 Accommodation Unit

- For cabins & mess rooms
- 2-way speaker
- Calling signal & PTT
- Privacy functionality
- CALL and TALK button
- IP-31 Rating



Size (WxHxD): 130x100x52 mm Wt: 0.3 kg

Item No. 4000015898

### P-9052 Substation

- 2-way speaker
- Stainless steel AISI 316 front
- IP-55
- CALL button
- Splash proof



Size (WxHxD): 130x100x52 mm Wt: 0.6 kg

Item No. 4000016947

### P-9135 Engine Control Room Telephone

- Call Lamp



Size (WxHxD): 144x240x33 mm Wt: 0.8 kg

Item No. 4000017572

### P-9003 Substation for Headset with Relay

- Built-in call relay, max 8A
- Call lamp
- Plug for connection of headset or handheld microphone
- CALL button
- IP-56 Rating



Size (WxHxD): 100x130x52 mm Wt: 0.3 kg

Item No. 4000017573

### P-9004 Talk-Back Call Unit

- 2-way loudspeaker connection
- CALL button
- IP-56 Rating



Size (WxHxD): 100x130x52 mm Wt: 0.3 kg

Item No. 4000017574

### P-9009 Call Unit with Socket

- Connector for portable talk-back unit P-0010
- CALL button
- IP-56 Rating



Size (WxHxD): 100x130x52 mm Wt: 0.3 kg

Item No. 4000011252

### P-0010 Portable Talk-Back Unit

- PTT
- Saltwater resistant
- Curled cable and plug
- Weatherproof
- 10m cable & plug for P-9009



Size (WxH): 139x197 mm Wt: 1.9 kg

Item No. 4000011254

### P-0012 Control Unit for Predefined Zones

- Console Mounted
- Goose Neck Microphone



Size (WxHxD): 120x80x70 mm Wt: 0.3 kg

Item No. 4000011255

### P-0013 Bridge Wing Unit with Microphone Contact

- Microphone contact
- Loudspeaker connection
- Watertight



Size (WxHxD): 100x130x52 mm Wt: 3.0 kg

Item No. 4000017576

### P-9016 Substation for Loudspeaker

- Built-in call relay, maximum 8A
- Call lamp
- Plug for connection of headset or handheld microphone
- CALL button
- Selector switch for headset or loudspeaker operation
- IP-56 Rating



Size (WxHxD): 100x130x52 mm Wt: 0.3 kg

Item No. 4000011262

### P-0019 Line Amplifier 24VDC

- 25W, 4 ohm
- IP-65 Rating
- 24VDC



Size (WxHxD): : 120x220x90 mm Wt: 1.65 kg

Item No. 4000016134

### P-9024 Line Amplifier 120W

- 120 watts
- 220 VAC / 24 VDC



Size: 19" 3U mm Wt: 14 kg

Item No. 4000017577

### P-9041 Interface for Ex Substation

- Interface for Ex Substation
- 1 Line
- IP-56 Rating



Size (WxHxD): 100x130x52 mm Wt: 0.3 kg

Item No. 4000013172

### P-9043 Interface for Ex Substation

- Interface for Ex Substation
- 3 Lines



Size (WxHxD): 150x200x75 mm Wt: 0.3 kg

Item No. 4000014279

### P-9018 Bridge Wing Telephone

- For indoor use
- With handset



Size (WxHxD): 210x96x147 mm Wt: 1.5 kg

Item No. 4000015069

### P-9013 Bridge Wing Unit

- Microphone contact
- Loudspeaker connection
- Indoor use



Size (WxHxD): 96x144x52 mm Wt: 0.25 kg

Item No. 4000014823

### P-9014 Power Supply

- Power Supply
- 220 /110VAC – 24VDC, 3A



Size (WxHxD): 210x160x102 mm Wt: 0.9 kg

# HOSPITAL AND REFRIGERATOR ALARM SYSTEM: PHONTECH ITCS

The ITCS system is designed for using onboard ships for calling from hospital and refrigerating rooms. It can be delivered as "Call from Hospital", "Call from Refrigerating Room" or "Call from Hospital and Refrigerating Room". The system is realized using units ITCS-1A (single) or ITCS-2A (dual) and arbitrarily numbers or peripheral units like ITCS-C1, ITCS-C2 or ITCS-C3.

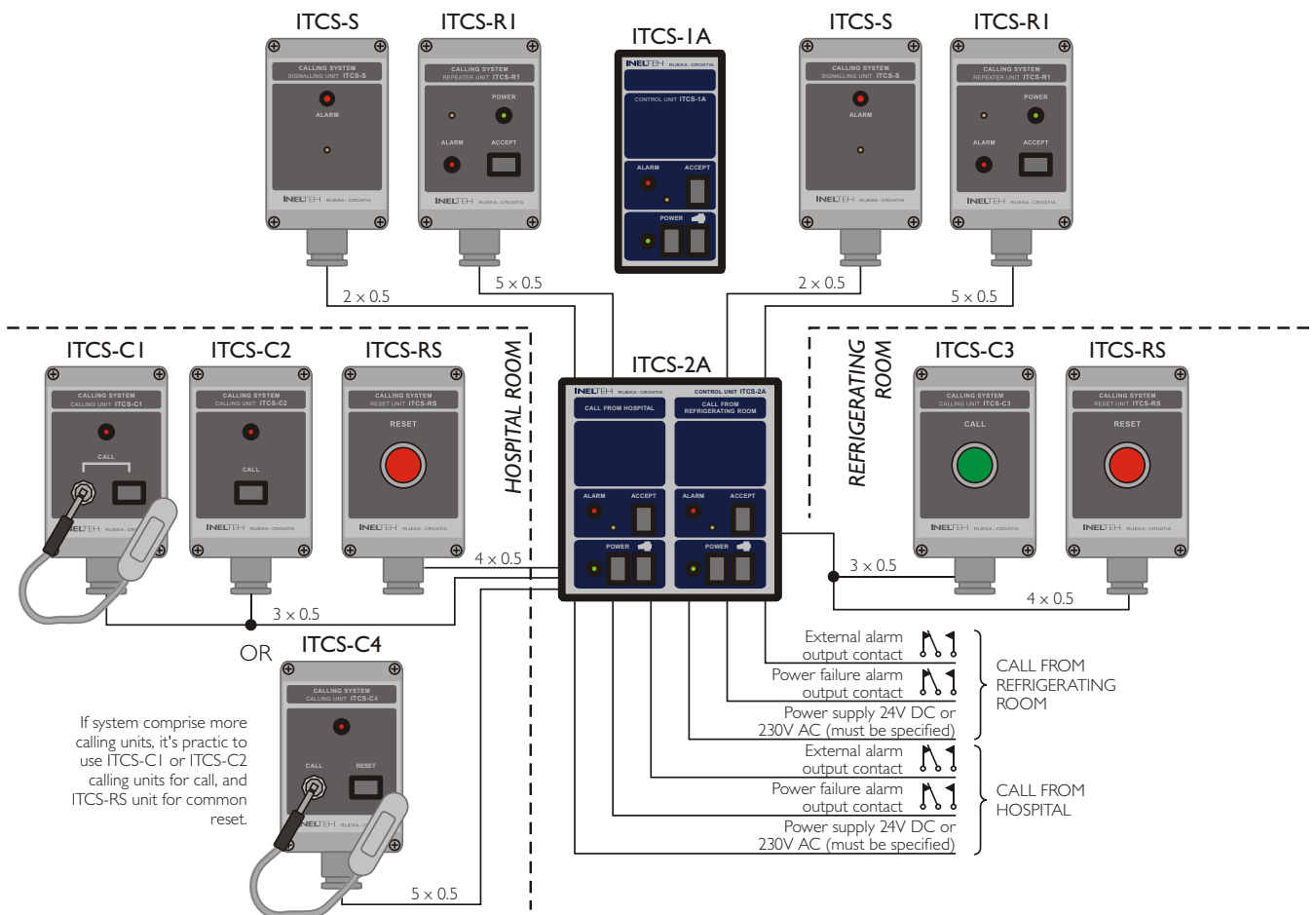



Item No. 4000018411

### ITCS-1A Call Unit, Single

- Single call indication
- Flush mounted
- 24 VDC



Size (WxHxD): 72x144x86 mm Wt: 0.35 kg

Item No. 4000018932

### ITCS-1A Control Unit, Single

- Single call indication
- Flush mounted
- 230 VAC



Size (WxHxD): 72x144x86 mm Wt: 0.95 kg

Item No. 4000018412

### ITCS-2A Control Unit, Dual

- Double call indication
- Flush mounted
- 24 VDC



Size (WxHxD): 144x144x86 mm Wt: 0.65 kg

Item No. 4000018931

### ITCS-2A Control Unit, Dual

- Double call indication
- Flush mounted
- 230 VAC



Size (WxHxD): 144x144x86 mm Wt: 1.86 kg

Item No. 4000018462

### ITCS-R1 Repeater, Bulkhead

- With LED & buzzer
- Bulkhead mounted



Size (WxHxD): 80x155x58 mm Wt: 0.25 kg

Item No. 4000016468

### ITCS-C1 Hospital Call Unit

- With Push Button on Cable
- Bulkhead mounted



Size (WxHxD): 80x125x85 mm Wt: 0.35 kg

Item No. 4000016469

### ITCS-C2 General Call Unit

- Bulkhead mounted



Size (WxHxD): 80x125x58mm Wt: 0.2 kg

Item No. 4000016470

### ITCS-C3 Refrigerator Unit

- Bulkhead mounted
- With Illuminated Push Button
- IP-56 Rating



Size (WxHxD): 80x125x58mm Wt: 0.25 kg

Item No. 4000016471

### ITCS-S Additional Signaling Unit

- With LED & buzzer
- Bulkhead mounted



Size (WxHxD): 80x125x58 mm Wt: 0.24 kg

Item No. 4000018413

### ITCS-RS Reset Unit

- Bulkhead mounted



Size (WxHxD): 80x125x58 mm Wt: 0.24 kg

Item No. 4000018415

### ITCS-C4 Hospital Call Unit

- With Push Button on Cable
- Reset Button
- Bulkhead mounted



Size (WxHxD): 80x125x58 mm Wt: 0.34 kg

# VSP Batteryless Telephone System

The VSP system is independent of the vessel's power supply and fulfils the demands for emergency communication between vital positions on board. The system has a versatile range of light but robust and corrosion-resistant stations for all on-board environments. The various VSP stations can be delivered for panel, desktop or bulkhead mounting.

## Three Systems

- 12-Way system consisting of up to 12 main stations with selector switch for selective calling between all connected stations
- 20-Way (M) system consisting of up to 20 main stations with selector switch for selective calling between all connected stations
- Intrinsically safe VSP set for units in hazardous areas  
Note! For 12-Way only

## Features

- Provides emergency communication independent of the vessel's power supply
- Excellent speech quality
- Model with noise compensated microphones
- Model built-in or separate relay for operation of signal units
- Supports headset directly connected to stations or via plug box
- Supports a wide range of stations for ship environment

## Approvals

- The system is tested according to IEC60945, and is type approved by DNV, LR, Rina, RMRS, CCS, ABS, RRR, GL, PRS, CRS



## Example 12-Way System

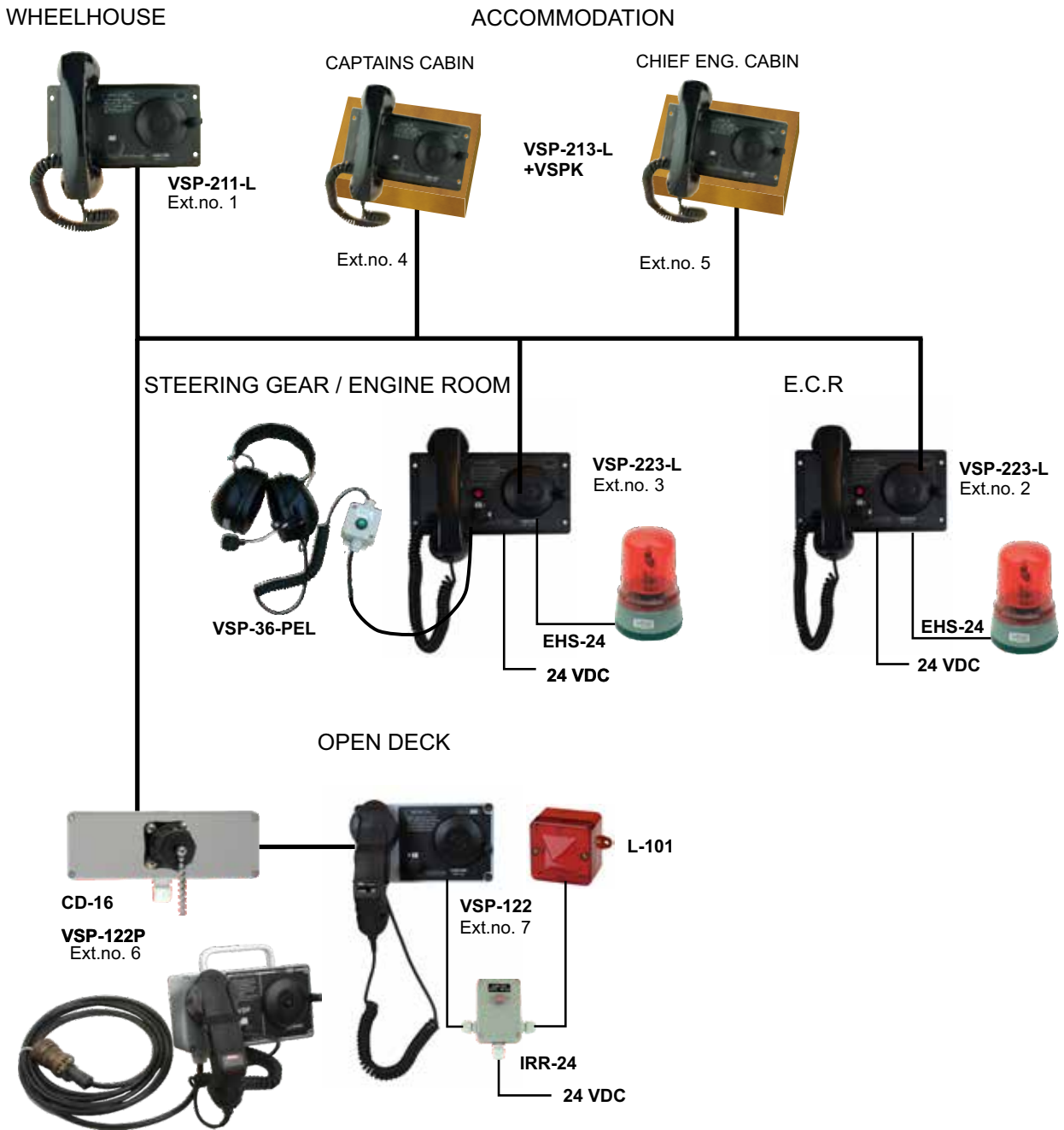

## 12-Way Telephone System



1020600931

### VSP-211-L Main Station, Panel Mounted

- Delivered with 12 positions selector switch
- Equipped with the built-in system amplifier w/ capacitor battery
- Terminals for auxiliary 24V DC when used as Common Battery Telephones
- Bulkhead mounted by use of corresponding on-wall metal box, type MBOKS
- Suitable for installation in wheelhouse and control room



**Size (WxHxD):** 238 x 214 x 137 mm (w/handset and built-in depth) **Weight:** 1.3 kg

Additional Information: IP-44, To avoid noise problems, the 24 VDC must be supplied via a DC/DC converter

1020600943

### VSP-223-L Main Station, Panel Mounted with Built-In Relay Circuit - 24V DC

- Delivered with 12 positions selector switch
- Alarm stop button
- Noise compensated microphone
- Optical LED call indication at front (in addition to audible call signal)
- Bulkhead mounted by use of corresponding on-wall metal box, type MBOKS
- Suitable for installation in control rooms and noisy areas like steering gear, engine- and thruster rooms



**Size (WxHxD):** 238 x 214 x 137 mm (w/handset) **Weight:** 1.3 kg

Additional Information: IP-44

1020600935

### VSP-213-L Main Station, Panel Mounted, Indoor Unit

- Delivered with 12 position selector switch
- Desk or wall mounted by use of a corresponding wooden cabinet, type VSPK
- Wall mounted by use of a corresponding on-wall metal box, type MBOKS
- Suitable for installation in wheelhouse, control room or accommodations



**Size (WxHxD):** 238 x 214 x 137 mm (w/handset and built-in depth) **Weight:** 1.3 kg

Additional Information: IP-44

1020600910

### VSP-122 Main Station, Watertight

- Wall mounting
- 12 extensions selector
- Has watertight housing
- For use in bridge wings and open deck areas.



**Size (WxHxD):** 220 x 220 x 185 mm (w/handset) **Weight:** 2 kg

Additional Information: IP-66

3006200024

### VSP-122P Main Station, Portable Watertight

- Portable substation
- 12 extensions selector
- Waterproof housing
- Carry handle and 5 meter cable with 16 pins Amphenol plug
- Used together with CD-16 in bridge wings and open deck areas.



**Size (WxHxD):** 220 x 220 x 185 mm (w/handset) **Weight:** 2.6 kg

Additional Information: IP-66

## 20-Way Telephone System



3006200025

### VSP-211M-L Main Station, Panel Mounted

- Equipped with a built-in system amplifier with capacitor battery
- Terminals for auxiliary 24 VDC when used as Common battery Telephones
- Optical LED call indication in front
- Delivered for flush or bulkhead mounting by use of an on-wall metal or wooden box
- Suitable for installation in wheelhouse and control rooms



**Size (WxHxD):** 238 x 214 x 137 mm (w/handset and built-in depth) **Weight:** 1.3 kg

Additional Information: IP-44, To avoid noise problems, the 24 VDC must be supplied via a DC/DC converter

3006200028

### VSP-212M-L Main Station, Panel Mounted with Built-In Relay Circuit - 24V

- Equipped with built-in relay latch timer for activation of external visible or audible 24V DC signal units
- Alarm stop button
- Noise compensated microphone



**Size (WxHxD):** 238 x 214 x 137 mm (w/handset and built-in depth) **Weight:** 1.3 kg

Additional Information: IP-44

3006200030

### VSP-22M Main Station, Watertight

- For bulkhead mounting
- Watertight housing for use in bridge wings and open deck areas



**Size (WxHxD):** 220 x 222 x 185 mm (w/handset) **Weight:** 2.4 kg

Additional Information: IP-66

3006200029

### VSP-213M-L Main Station, Panel Mounted, Indoor

- Optical LED call indication at front
- Delivered for flush- or bulkhead mounting by use of an on-wall metal or wooden box
- Desk or wall mounted by use of the wooden cabinet, type VSPK
- Wall mounted by use of a corresponding on-wall metal box, type MBOKS
- Suitable for installation in accommodations and control rooms



**Size (WxHxD):** 238 x 214 x 137 mm (w/handset and built-in depth) **Weight:** 1.3 kg

Additional Information: IP-44

## Manuals

A100K10873

VSP 12-Way Technical Manual

A100K10675

VSP 12-Way User Guide

A100K10758

VSP-M 20-Way Technical Manual

A100K10756

VSP-M 20-Way User Guide



# VSP Intrinsically Safe Set for Ex II 1G Area

An Intrinsically Safe VSP Set consists of a Buffer Unit mounted in a safe area and the VSP-512 Operating Unit, with optional headset and call signal, mounted in the hazardous area. The Buffer Unit can be delivered in different versions, depending on the number of stations to be called. The buffer unit must be powered by 24V DC.

Making a call from the VSP-512 Operating Unit in the hazardous area to VSP stations in the safe area is simple: Turn the selector switch to the desired extension number and press the call button. Lift the handset and keep the handset button pressed during the conversation.

## Features

- For use in hazardous areas
- ATEX and IECEx approved
- Excellent speech quality
- Easy to use
- Support up to 12 Main stations in Ex II 1G area
- 4 x 24V DC outputs to Ex signal units.
- Additional 24V DC outputs to Ex signal units on request
- 4-12 call signal outputs to safe area depending on buffer version
- Require 24V DC to operate
- Optional headset connected directly to main station
- Compatible with VSP 12-way system

## Certificate

- ATEX Certificate number Presafe 15 ATEX 6475
- IECEx Certificate number IECEx PRE 15.0024

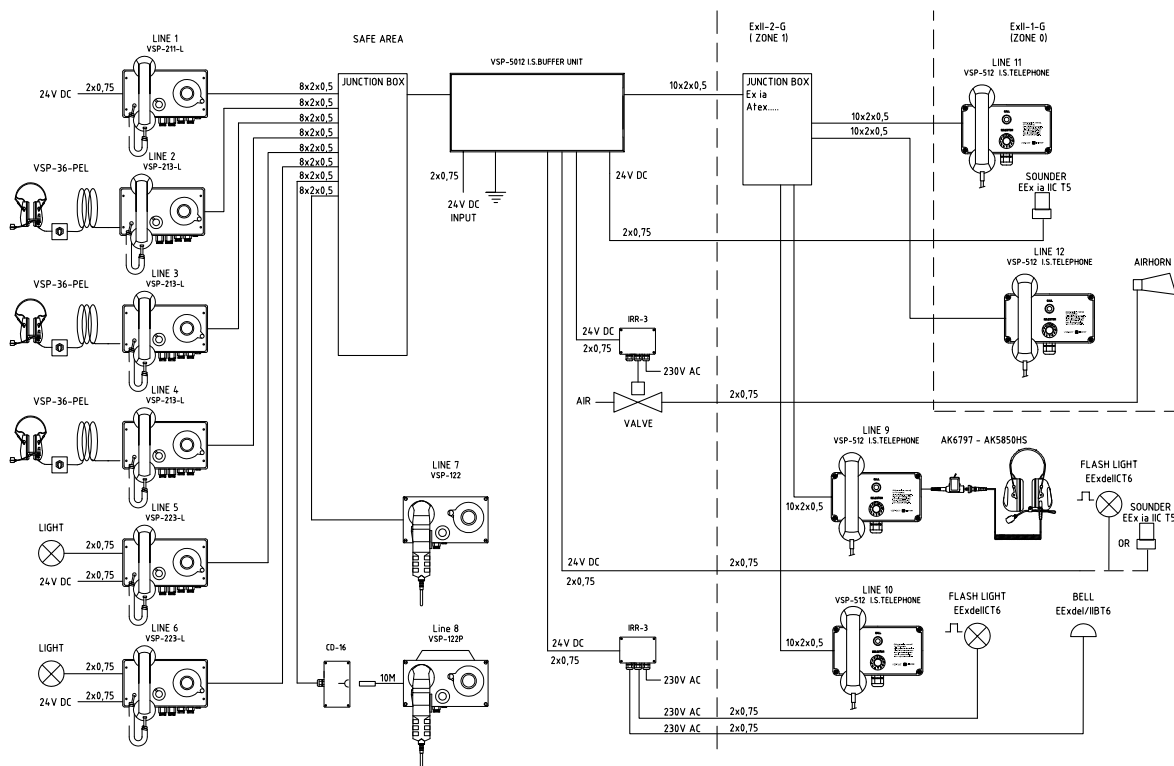

## VSP Ex Units

3006200037

### VSP-5004 Ex Buffer Unit in Safe Area, Selective Calls to 4 Stations

- 4 call signal outputs to safe and EX area
- Signal output for 4 stations in hazardous area
- Metal cabinet RAL7032
- Wall mounting

**Size (WxHxD): 450 x 300 x 200 mm Weight: 11 kg**

Additional information: IP-44



3006200038

### VSP-5004/1 Ex Buffer Unit in Safe Area, Selective Calls to 4 Stations with 1x Zener Barrier

- 4 call signal outputs to safe and EX area
- Delivered with 1x zener barrier for 24 VDC Ex sounder IS28-MK5 in zone 0
- Signal output for 1 station in hazardous area
- Metal cabinet RAL7032
- Wall mounting

**Size (WxHxD): 450 x 300 x 200 mm Weight: 11 kg**

Additional information: IP-44  
3006200006 Ex sounder IS28-MK5

3006200039

### VSP-5004/2 Ex Buffer Unit in Safe Area, Selective Calls to 4 Stations with 2x Zener Barrier

- 4 call signal outputs to safe and EX area
- Delivered with 2 x zener barriers for 24 VDC Ex sounder IS28-MK5 in zone 0
- Signal output for 2 stations in hazardous area
- Metal cabinet RAL7032
- Wall mounting

**Size (WxHxD): 450 x 300 x 200 mm Weight: 11 kg**

Additional information: IP-44  
3006200006 Ex sounder IS28-MK5

3006200040 / 3006200041

### VSP-5008 Ex Buffer Unit in Safe Area, Selective Calls to 8 Stations

- 8 call signal outputs to safe and EX area
- Signal output for 4 stations in hazardous area
- Metal cabinet RAL7032
- Wall mounting
- 3006200041: with 2 zener barriers

**Size (WxHxD): 450 x 300 x 200 mm Weight: 11 kg**

Additional information: IP-44

3006200042 / 3006200043

### VSP-5012 Ex Buffer Unit in Safe Area, Selective Calls to 12 Stations

- 12 call signal outputs to safe and EX area
- Signal output for 4 stations in hazardous area
- Metal cabinet RAL7032
- Wall mounting
- 3006200043: with 1 zener barrier

**Size (WxHxD): 450 x 300 x 200 mm Weight: 11 kg**

Additional information: IP-44

3006200044

### VSP-512 Intrinsically Safe Operating Unit

- Suitable for mounting in hazardous areas Ex II 1G (Zone 0)
- Delivered with a 12 position selector switch and a call button
- Used together with buffer unit mounted in safe area
- Delivered for bulk-head mounting



**Size (WxHxD): 220 x 208 x 170 mm Weight: 1.8 kg**

Additional Information: IP-66

2330040025 / 2330040029

### VSP-512-AKHS-10/20 Headset with Headband ATEX/IECEx Certified

- Rugged headset for EX application zone 1
- Noise-cancelling microphone
- High quality digital background noise reduction
- High quality audio
- Optional in-ear monitors may be connected for added damping in extreme environments
- Standard 4-pole Nexus connector for easy connection/replacement
- 2330040025: with latching cable 10 m
- 2330040029: with latching cable 20 m



**Weight: 0.4 kg (Headset)**

Additional Information: IP-66

# Information & Entertainment Systems

<b>Infotainment &amp; IPTV System</b>	<b>58</b>
<b>Servers / Gateways / Encoders / Transcoders</b>	<b>59</b>
<b>TV Sets / Set-Top Boxes / Pheripheral Equipment</b>	<b>61</b>
<b>IP CCTV Systems</b>	<b>63</b>
<b>Rack &amp; Monitor Equipment</b>	<b>64</b>
<b>Indoor IP Cameras</b>	<b>65</b>
<b>Outdoor IP Cameras</b>	<b>66</b>
<b>Ex IP Cameras</b>	<b>68</b>
<b>Master Clock System</b>	<b>69</b>
<b>Master Clock Units</b>	<b>70</b>

# Infotainment & IPTV System

The Vingtor-Stentofon Infotainment & IPTV system with its comprehensive functionality in a highly HW-efficient setup is ideal for marine vessels. Based on forefront technology, the IPTV system is easy to set up and configure, and provides customized interactive solutions in addition to conventional TV channels. The IPTV technology enables broadcast television via IP networks with HD video and multi-channel audio. The IP protocol enables two-way connections between head-end and set-top boxes. Due to the features mentioned, users can enjoy interactive TV and other media features not available to conventional television subscribers.

## IPTV Benefits

- **Integration:** The functionality of the IPTV system can be extended through integration with other systems such as CCTV and ECDIS as well as displaying information from communication systems.
- **Space Efficient:** Provides a wide range of functions with few components.
- **Access to all digital TV signals:** Digital terrestrial and satellite signals can all be combined in the same IPTV server without the need for additional HW or licenses.
- **Versatile:** The set-top boxes run on an Android platform, enabling access to applications such as web browsing, e-mail, Skype, social media apps, etc. from any TV.
- **Video on Demand (VoD):** This is the individual delivery of video content to a subscriber. This service allows its users to watch any movie from the VoD server's media library. The subscriber can use the pause and rewind functions.
- **Time-Shifted TV adds interactive features to TV channel viewing:** The subscriber can pause the playback at any time and resume it later. There is also a rewind option for TV programs.
- **TV on Demand (TVoD):** The selected TV channels are recorded and stored for a predefined period and is available for viewing individually on each TV.
- **3D Support:** Users can watch live 3D TV channels as well as 3D movies from the VoD server's media library.
- **4K UHD Support:** Users can watch live 4K UHD TV channels as well as 4K UHD movies from the VoD server's media library.



# IPTV Servers Gateways Encoders Transcoders

2320005018 / 2320005019

## IPTV Server 8000 V2

- All-in-one IPTV solution for small to medium size installations
- All systems integrated
- High density
- Easy and intuitive user interface
- 3D and 4K UHD support
- Customizable themes
- Optional Interface to Property Management Systems (PMS)
- 2320005018: with 1 TB of HDD space
- 2320005019: with 8 TB of HDD space



Size (WxHxD): 19" 1HU, 440 x 44 x 410 mm  
Weight: 8.8 kg

2320005053

## DVB to IP Gateway 8X V2

- 8 x DVB-S/S2/T/T2/C inputs
- 8 x CI slots



Size (WxHxD): 19" 1HU, 440 x 44 x 410 mm  
Weight: 8.8 kg

2320005013

## ATSC to IP Gateway 8x

- 8 x ATSC Receivers
- 1 x IP output

**Note: For terrestrial signals in USA and Canada!**



Size (WxHxD): 19" 1HU, 440 x 44 x 410mm  
Weight: 4 kg

2320005016

## FM to IP Gateway 8x

- 4 FM antenna inputs
- 8 FM radio stations



Size (WxHxD): 19" 1HU, 440 x 44 x 410mm  
Weight: 4 kg

2320005048

## HDMI Encoder 1000

- IP Output over UDP (Multicast) RTP, RTSP, HTTP, HLS
- 1 x HDMI input
- 1 x audio input



Size (WxHxD): 170 x 130 x 30 mm  
Weight: 0.5 kg

2320005012

## HDMI Encoder 8X

- 8 x HDMI inputs
- 1 x ASI input, BNC
- 1 x ASI output
- 1 x IP output



Size (WxHxD): 19" 1HU, 440 x 44 x 410mm  
Weight: 4 kg

2320005003

## MPEG-2 Encoder 8X

- 8x AV inputs
- 1x ASI input
- 1x ASI output
- 1x IP output



Size (WxHxD): 19" 1HU, 440 x 44 x 455 mm  
Weight: 4 kg

2320005054

## Audio Encoder 4000

- IP Output over UDP (Multicast) RTP, RTSP, HTTP, HLS
- 1 x audio input



Size (WxHxD): 170 x 130 x 30 mm  
Weight: 0.5 kg

2320005015

### Transcoder Server 2000

- Streaming as multicast (UDP) or unicast (HTTP)
- Used for transcoding from MPEG-2 to H.264 or vice versa
- 8GB memory, 240GB SSD



Size (WxHxD): 19" 4HU, 430 x176 x 445 mm  
Weight: 22 kg

2320005011

### Control Server 2000

- CPU: Intel Core I7, 8MB cache, GPU, Quad core
- Memory: 8 GB, DDR3 1333, KIT 2x4 GB
- SSD: Intel Series 530, Sata3, 240.00 GB
- Additional Controller: 2x serial, 1x parallel
- Additional LAN card PCI-E 10/100/1000
- DVD+-RW drive
- Operating System: Windows 10 Pro



Size (WxHxD): 19" 4HU, 430 x176 x 445 mm  
Weight: 22 kg

2320005009

### TVoD Server 3000

- View recent TV programs
- Pause or rewind TV programs
- Easy to setup and maintain
- After power loss it automatically powers on and starts recording and TV playback on-demand
- Storage space: SATA3 2x1500.00 GB = 3000.00 GB (enough for recording 25 channels for 2 days with average frame rate of 4 Mb/s)



Size (WxHxD): 19" 4HU, 430 x176 x 445 mm  
Weight: 22 kg

2320005010

### TVoD Server 8000

- View recent TV programs
- Pause or rewind TV programs
- Easy to setup and maintain
- After power loss it automatically powers on and starts recording and TV playback on-demand
- Storage space: SATA3 2x4000.00 GB = 8000.00 GB (enough for recording 30 channels for 4 days with average frame rate of 4 Mb/s)



Size (WxHxD): 19" 4HU, 430 x176 x 445 mm  
Weight: 22 kg

3006204193

### Alarm Input Interface Module with Software

- Mute/Turn off TV during alarm
- Send dynamic message to screen
- External power 18-36 VDC external power
- 6 inputs contacts (NO)



Size (WxHxD): 88 x 90 x 58 mm  
Weight: 0.2 kg



# IPTV TV Sets Set-Top Boxes Peripheral Equipment



2320005046

## APC395X Android STB

- Remote Control
- 2xUSB, 1xMicro SD, HDMI, RJ45, 802.11 b/g/n Wi-Fi module
- Power adapter US/UK/EU plug



Size (WxHxD) 100 x 24 x 105 mm Weight: 0.147 kg

2320005088

## 24" LED TV with Integrated STB

- STB mounted on back side and powered through TV
- IR loop
- 1x Remote Control



Additional Information:  
2320005062 TV Wall Mount Bracket

2320005022

## 32" LED TV with Integrated STB

- STB mounted on back side and powered through TV
- IR loop
- 1x Remote Control



Additional Information:  
2320005062 TV Wall Mount Bracket

2320005024

## 40" LED TV with Integrated STB

- STB mounted on back side and powered through TV
- Full HD
- 1x Remote Control for TV and STB



Additional Information:  
2320005062 TV Wall Mount Bracket

2320005036

## 43" LED TV with Integrated STB

- STB mounted on back side and powered through TV
- Full HD
- 1x Remote Control for TV and STB



Additional Information:  
2320005060 TV Wall Mount Bracket

2320005087

## 49" UHD TV with Integrated STB

- STB mounted on back side and powered through TV
- IR loop
- 1x Remote Control



Additional Information:  
2320005060 TV Wall Mount Bracket

2320005081

## 55" UHD TV with Integrated STB

- STB mounted on back side and powered through TV
- IR loop
- 1x Remote Control



Additional Information:  
2320005060 TV Wall Mount Bracket

2320005035

## 65" LED TV with Integrated STB

- STB mounted on back side and powered through TV
- Full HD
- 1x Remote Control



Additional Information:  
2320005060 TV Wall Mount Bracket

2320005072

### 55" Sony UHD LED TV with Integrated STB

- STB mounted on back side and powered through TV
- IR loop
- 1x Remote Control



Additional Information:  
2320005060 TV Wall Mount Bracket

2320005082

### 65" Sony UHD LED TV with Integrated STB

- STB mounted on back side and powered through TV
- IR loop
- 1x Remote Control



Additional Information:  
2320005060 TV Wall Mount Bracket

2320005085

### 75" Sony UHD LED TV with Integrated STB

- STB mounted on back side and powered through TV
- IR loop
- 1x Remote Control



Additional Information:  
2320005060 TV Wall Mount Bracket

2320005075

### 85" Sony UHD LED TV with Integrated STB

- STB mounted on back side and powered through TV
- IR loop
- 1x Remote Control



Additional Information:  
2320005060 TV Wall Mount Bracket

2320005041

### K400 Plus Wireless Keyboard with Touchpad

- Wireless Protocol 2.4 GHz (Unifying)
- Wireless Range Up to 33 Feet or 10 Meters
- Receiver USB 2.0



Size (WxDxH) 354 x 136 x 24 mm Weight: 0.360 kg

Additional Information: 2xAA (Alkaline), Removable/ Replaceable

2320005060

### BT8432/B TV Wall Mount Bracket with Tilt

- Screen size: up to 80"
- Max. weight: 70kg (35kg when pole mounted)
- Simple tilt adjustment: +/- 15°
- Mounting holes spacing: Fits VESA mounting from 75x75mm to 800x400mm



Size (WxHxD) 865 x 500 x 80mm Weight: 6 kg

2320005062

### LCY-042T TV Wall Mount Bracket with Tilt & Swivel

- Screen size: 17" – 42"
- Max. weight: 30kg
- Vertical adjustment: +/- 20°
- Horizontal adjustment: +/- 30°
- Mounting holes spacing: Fits VESA mounting from 75x75mm to 200x200mm



Size (WxHxD) 235 x 230 x 100mm Weight: 1.1kg

# IP CCTV System

The CCTV system enables cost-effective, high quality area monitoring and video surveillance that enhance the safety and security of the crew.

The system is available in different versions and offers a set of standard and optional features which covers the requirements for a marine system.

It can be delivered as a standalone system or as functional modules fully integrated into the ACM Advanced system. The system is scalable with options for combining IP CCTV and analog CCTV.

## Features

- Delivered as a standalone system or as integrated modules in the ACM Advanced system
- Flexible system with possibility of combining IP and analog cameras.
- All IP cameras supporting H.264 video compression for high image quality on lower bandwidth.
- All cameras from globally known brands
- Standard fixed IP cameras supporting PoE
- IP network infrastructure and Cost-effective solution
- Can easily be integrated with Infotainment solutions
- Varied range of cameras available for both indoor and outdoor marine applications, including fixed, P/T and Ex cameras

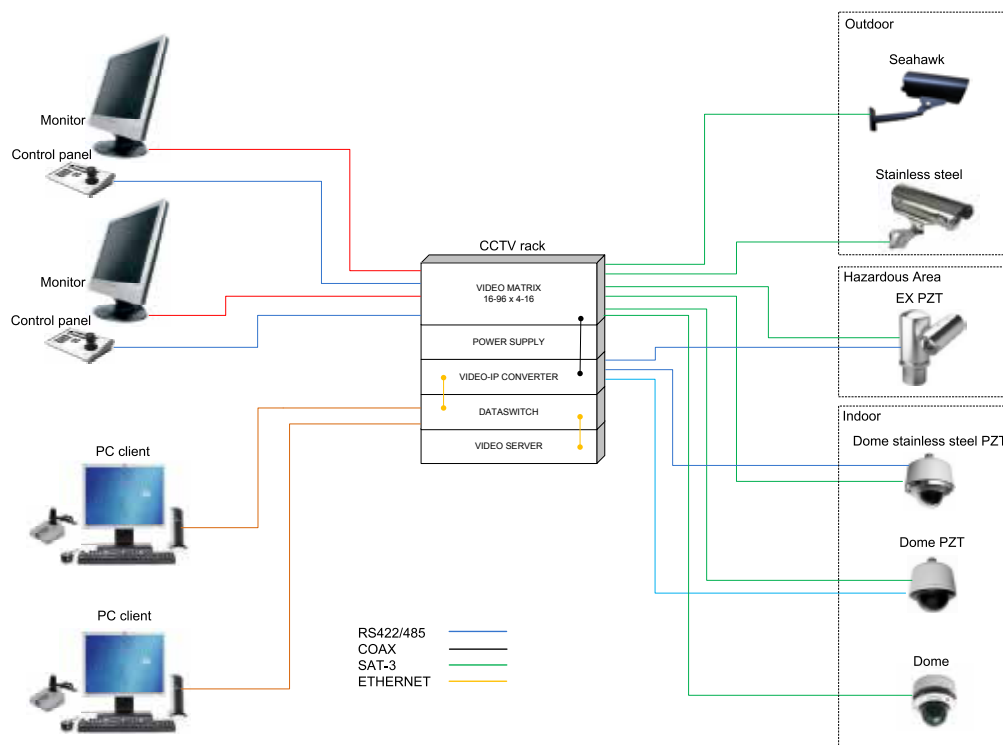

## Rack & Monitor Equipment

2310120201

### CE-NVR-16/4POE Network Video Recorder

- Dual-OS design to ensure high reliability
- ANR technology to enhance the storage reliability when the network is disconnected
- H.265/H.264/MPEG4 video formats
- Connectable to the third-party network cameras
- Up to 16 IP cameras can be connected
- Recording at up to 12 MP resolution
- Supports live view, storage, and playback of the connected camera at up to 12 MP resolution
- HDMI and VGA outputs provided
- HDMI Video output up to 4K (3840×2160) res.
- Up to 4 SATA interfaces connectable for recording and backup
- Storage space effectively saved by 50% to 70% with the use of H.264+ decoding format
- 1 self-adaptive 10M/100M/1000M network interface
- 16 independent PoE network interfaces provided



Size (WxHxD): 445 x 390 x 70 mm Weight: 5 kg

2310120202

### CE-NVR-32/16 Network Video Recorder

- HDD hot swap with RAID0, RAID1, RAID5, RAID6 and RAID10 storage scheme configurable
- Either Normal or Hot Spare working mode is configurable to constitute N+1 hot spare system
- H.265/H.264+/H.264/MPEG4 video formats
- Connectable to the third-party network cameras
- Up to 64 IP cameras can be connected
- Recording at up to 12 MP resolution
- Supports live view, storage, and playback of the connected camera at up to 12 MP resolution
- HDMI1/VGA1 and HDMI2/VGA2 outputs provided
- HDMI1 Video output at up to 4K (3840 × 2160) res.
- Up to 16 SATA interfaces and 1 eSATA interface connectable for recording and backup
- Storage space effectively saved by 50% to 70% with the use of H.264+ decoding format
- 2 self-adaptive 10M/100M/1000M network interfaces, and two working modes are configurable: multi-address and network fault tolerance



Size (WxHxD): 445 x 496 x 146 mm Weight: 12.5 kg

2310120203

### CE-NVR-128/16 Network Video Recorder

- Pluggable HDD design provides convenient HDD installation and maintenance
- Professional embedded hardware and software, and pioneering dual-OS design to ensure the reliability of system running.
- Adopts ANR technology to enhance the storage reliability when the network disconnected.
- Supports HDD hot swap with RAID0, RAID1, RAID5, RAID 6, and RAID10 storage scheme
- Either normal or hot spare working mode is configurable to constitute N+1 hot spare system
- Connectable to third-party network cameras like ACT1, Arecont, AXIS, Bosch, Brickcom, Canon, ONVIF, PANASONIC, Pelco, PSIA, SAMSUNG, SANYO, SONY, Vivotek and ZAVIO.
- Up to 128 IP cameras can be connected.
- Video outputs at up to 4K (4096×2160) resolution
- Supports decoding up to 20 channels at 1080p res.
- Up to 16 SATA interfaces and 1 eSATA interface connectable for recording and backup



Size (WxHxD): 442 x 494 x 146 mm Weight: 16 kg

2310120101

### DS-1005KI USB Joystick & Keyboard

- Power supply and communication via USB port
- 3D PTZ control and 2 joystick control buttons
- Up to 15 programmable buttons are available



Size (WxHxD): 167×177.5×116 mm Weight: 1.2 kg

2310120056

### KSML-92 Flush Mount Keyboard IEC60945 Compliant

- 92-key backlit keyboard is approved for use with SOLAS Marine applications (ECDIS)



Size (WxHxD): 385x185x50 mm Weight: 1.2 kg

2310120094

### HD 19T21 19" Marine Display IEC60945 Approved

- High Quality TFT with LED Backlight
- 19.0 inch viewable image size, Aspect Ratio 5:4
- TFT active-matrix liquid crystal panel
- MVA (Multi-domain Vertical Alignment) LCD Technology



Size (WxHxD): 429 x 382 x 74.5 mm Weight: 7.8 kg

## Indoor IP Cameras

2310111106

### DS-2CD4A26FWD-IZHS Indoor IP Fixed Camera

- 1/1.8" Progressive Scan CMOS
- Full HD1080p video
- Up to 60fps frame rate
- Ultra-low light
- Slow shutter
- 120dB WDR
- 3D DNR
- Up to 50m IR range
- Motorized lens with Smart Focus
- Built-in heater
- Audio/alarm I/O
- Support 128G on-board storage
- DC12V/PoE



Size (WxHxD): 100x103.9x311.8 mm Weight: 2 kg

2310111102

### IC-NDC-2MP IP Dome Camera

- 1/2.8" Progressive Scan CMOS
- Indoor WDR dome camera
- 2MP resolution
- Motorized lens 2.8-12mm
- Up to 30 meters IR range
- Built-in Micro SD/SDHC/SDXC card slot, up to 128 GB
- Audio/alarm I/O (-S)
- Mobile Monitoring via EZVIZ P2P or iVMS-4500
- 12V DC±25% & PoE(802.3af Class 3)
- Support H.264+



Size: (W x Ø): 140 x 99.9 mm Weight: 1 kg

Additional Information: IP-67

2310111147

### DS-2TD2636-10 IP Thermal Camera

- Aluminum housing
- Leading image processing technology: Adaptive AGC, DDE, 3D DNR, NETD less than 40 mk (0.04°C), F#≈1.0
- Powerful behavior analysis function, based on deep learning algorithm: Line crossing, Intrusion, Region Entrance & Exit
- Reliable temperature exception alarm function
- Advanced fire detection algorithm
- Bi-spectrum image fusion, picture in picture preview
- 384 x 288 resolution sensor, high sensitivity sensor, support contrast adjustment
- Shutter adjustment in various modes
- 3D DNR, 15 palettes of color adjustable, image detail enhancement
- Mirror image, digital zoom x2, x4, x8, local output
- Thermal field of view 37 x 28 deg, 10mm lens
- Optical 1080p camera, 30-52deg, 6mm lens
- 24VAC or PoE+ supported (20W)



Size(HxWxL): 314mm x 104mm x 292.7 mm Wt: 1.55 kg

2310111114

### NDP-5502-Z30 Indoor IP Camera

- 30x optical zoom that clearly identifies people (183 m / 600 ft maximum) without loss of identification details
- Excellent low-light performance
- Built-in Essential Video Analytics to trigger relevant alerts and quickly retrieve data
- Simple installation with flexible mounting options (in-ceiling or pendant mounting)



Size(W x Ø): 207 mm x 303.6 mm Weight: 3.25 kg

Additional Information: IP-66

2310111144

### DS-2DE4425IW-DED IP Camera

- 1/2.5" progressive scan CMOS
- 2560;x 1440 @30fps resolution
- Ultra-low light:
  - Color: 0.005;Lux @(F1.6, AGC ON)
  - B/W: 0.001;Lux @(F1.6, AGC ON)
  - 0 Lux with IR
- 30x optical zoom
- 100m IR illumination
- 12VDC or PoE+ or High PoE midspan supported (18W)
- Support H.265+/H.265 video compression



Size(W x Ø): 164.5 x 290 mm Weight: 2 kg

2310111111

### DS-2CD6362F-IVS Fisheye IP Camera

- 1/1.8" progressive scan CMOS
- 6 mega-pixel image sensor
- Up to 3072 x 2048 resolution, 30fps
- 360° panoramic view
- Digital WDR
- Up to 15 live view display modes
- 2 behavior analyses, 1 statistic
- Virtual PTZ
- Up to 15m IR range
- Built-in microphone and speaker
- IK10 for camera housing, IP-66



Size (WxHxD): 164 x 152.8 x 43.8 mm Weight: 1.4 kg

## Outdoor IP Cameras

2310111107

### SH53HD Outdoor IP Camera

- IP-66/IP-67 Maritime models
- 53° horizontal field of view
- 4 Megapixel resolution
- Built-in 6mm fixed lens
- Min. Illumination Color : 0.3Lux, B/W : 0.03Lux
- True Day & Night
- Wide Dynamic Range 120dB
- Video Compression Format H.265, H.264, MJPEG
- Max. Frame rate H.265/H.264: Max. 30fps at all resolutions, MJPEG: Max. 15fps
- PoE (IEEE802.3af, Class3) Max 7W
- Motion detection, Tampering, Defocus detection



Size (Length w/ bracket 360 mm Weight: 2.7 kg

2310111036

### VHM-IP-BF Outdoor IP Camera

- Camera weather protection
- 3 cable entries M16x1.5mm
- Housing body length: 330mm
- PTC window heater 12-30V included
- Fold-down housing body
- Window glass with "Clear-Shield" technology
- 4 levels of camera height adjustment
- Incorporated carrier handle
- Insulated camera mounting
- Protection rating: IP66
- Integrated connection board
- Housing colour: RAL9016/RAL7035
- Outdoor mounting
- Heater, bracket and sun shield included
- Camera inside housing: 1080p 2.8 - 12 mm



Size (WxHxD): 473 x 124.6 x 133 mm Weight: 2.8 kg

2310111037

### 129WW-IP-MF Outdoor IP Camera

- ISI316L stainless steel construction
- For use in highly corrosive environments
- Easy installation and maintenance
- Integrated wiper version available
- Weatherproof standard IP66 / IP67
- Suitable for analog and IP cameras
- Day / Night and IR Thermal versions available
- Refined and modern design
- Camera inside housing: 1080p 2.8 - 12 mm



Size (WxHxD): 80 x 80 x 184 mm Weight: 2.8 kg

2310111065

### S6230-ESGL1 Outdoor IP Camera

- SureVision 3.0 Technology
- Up to Full HD 1080p and up to 60 Images per Second (ips)
- Power over Ethernet (HPoE and PoE+), 24 VAC, 24 VDC
- H.264 Smart Compression Technology
- Three Automatic Defog Options
- Electronic Image Stabilization (EIS)
- Built-in Analytics Suite
- Vandal Resistant IK10 Smoked or Clear Bubble
- SDXC Memory Card with up to 2TB
- Compatible with Pelco and Third-Party Video Systems



Size(Ø x W): 218 x 282 mm Weight: 3.1 kg

2310111100

### OC-NDC-2MP Outdoor IP Camera

- Up to 2 megapixel high resolution
- 120dB Wide Dynamic Range
- Three video streams
- H.265, H.265+, H.264, H.264+
- 6 behavior analyses, 2 exception detections, 1 recognition
- Support on-board storage, up to 128GB
- IR range: 10 m
- DC 12V/PoE
- Anti-Corrosion Standard: WF-2, NEMA 4X, C5-M
- IP-67



Size(Ø x W): 113 x 77.3 mm Weight: 1.7 kg

2310111101

### OC-PTZ-2MP Outdoor IP Camera

- Anti-corrosion stainless steel, effectively avoid acidic and neutral salt fog corrosion
- 1/1.9" HD CMOS sensor
- 2MP(1920\*1080) Full HD
- 23X Optical Zoom
- Ultra-low illumination
- 120dB True WDR
- 316L stainless steel
- WF2, C5-M, NEMA 4X anti-corrosion standard
- IP67 standard
- Smart Tracking, Smart Detection, EIS, Defog
- Hi-PoE / 24VAC power supply



Size(Ø x W): 262 x 330 mm Weight: 10 kg



2310111115

### DS-2CD6626DS-IZHS Outdoor IP Fixed Dome Camera

- 2 MP Ultra Low-Light ICR Anti-Corrosion Dome Camera
- 1/1.8" progressive scan CMOS
- Up to 1920 × 1080 resolution
- 120dB WDR, 3D DNR
- 316L stainless steel anti-corrosion materials design
- WF-2, C5-M anti-corrosion standards
- IR range: 10-30m
- 1 m pigtail included



Size(Ø x W): 165.4 × 126.2 mm Weight: 3.36 kg

2310111104

### DS-2CD6626B-IZHS Outdoor IP Bullet Camera

- Up to 1920\*1080 @ 60 fps
- Progressive scan CMOS with smooth and fluent capture for moving object
- Motorized zooming and auto focus
- H.265, H.265+, H.264, H.264+
- Ultra-low light
- 120dB WDR
- IR range: up to 80 m for 2.8 – 12mm lens. (Alternative up to 150 m for 8 – 32 mm lens)
- 316L stainless steel anti-corrosion materials design
- Anti-corrosion standard: C5-M, NEMA 4X
- IP-67 waterproof and dustproof for wet and watery environment

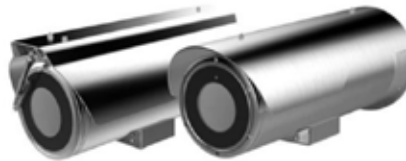

Size (WxHxD): 472 × 180 × 190 mm Weight: 9.75 kg

2310111109

### MIC-7502-Z30B Outdoor IP Camera

- Exceptional low-light performance
- Exceptional strength and ruggedness for any outdoor application including traffic monitoring (bridges, tunnels, or highways), perimeter protection, city surveillance and mining
- Built-in Intelligent Video Analytics alert operators in case of unusual scene activity
- Edge intelligence with Intelligent Tracking and object detection even when the camera is moving
- Excellent low-light sensitivity (color = 0.0077 lx) and High dynamic range (120 dB) (to see details in bright and dark areas simultaneously)
- Robust design rated to an industry-leading IP-68, Type 6P, IK10
- H.265 high-efficiency video encoding



Size (WxHxD): 218 × 369 × 178 mm Weight: 6.7 kg

2310111094

### NXPTZHD11VW0Z00B PTZ Camera

- LR Type approved PTZ IP camera, 316L stainless steel
- Camera Full HD 1080p, 30x, 60fps
- Integrated screen wiper
- 230VAC, 120W (optional models 24VAC, 120VAC)
- Video compression H.264/AVC, MJPEG, JPEG and MPEG4
- Up to 3 simultaneous video streams in FULL HD
- Operating temperature: from -40°C to +60°C
- Protection degree: IP-66, IP-67, IP-68, IP-69
- 3m pigtail included. JB needed for cable termination.



Size (WxHxD): 336x398x232 mm Weight: 22 kg

2310111148

### DS-2TD2466-25Y Thermal IP Camera

- Stainless steel Anti-Corrosion Bullet Camera
- Leading image processing technology: Adaptive AGC, DDE, 3D DNR, NETD less than 40 mk (0.04°C), F#=-1.0
- Powerful behavior analysis function, based on deep learning algorithm: Line crossing, Intrusion, Region Entrance & Exit
- Reliable temperature exception alarm function
- Advanced fire detection algorithm
- Thermal field of view 24.55 × 19.75 deg
- 640 × 512 resolution sensor, high sensitivity sensor, support contrast adjustment
- Shutter adjustment in various modes
- 3D DNR, 15 palettes of color adjustable, image detail enhancement
- 24VAC or PoE+ supported (20W)



Size (WxHxD): 310 × 25 × 263 mm Weight: 16.86 kg

2310111143

### DS-2XC6224G0-L Underwater IP Camera

- 1/2.8" Progressive Scan CMOS
- 1920 × 1080 @ 30fps
- 2.0/2.8/4.0mm fixed lens
- 120 dB wide dynamic range
- On-board storage, up to 128 GB
- Adaptability: up to 15m depth underwater
- 6 behavior analyses, 3 exception detection
- IP-68



Size (WxHxD): 210 × 200 × 205 mm Weight: 6.95 kg

## Ex IP Cameras

2310131017

### DS-2DF6236-CX IP Explosion-Proof Camera

- 2MP 1/1.9" progressive scan CMOS
- Up to 1920 × 1080 resolution
- 36× optical zoom, focal length 5.9 mm to 135.7 mm
- IR cut filter with auto switch
- 3D DNR, low bitrate, 120 dB WDR
- Three streams
- Supports H.265+/H.265 video compression
- Explosion-Proof
- IP-68



Size(Ø x W): 218 x 282 mm Weight: 3.1 kg

2310131022

### MVXHD2F0WAZ00A IP Explosion-Proof Camera

- Certifications for use in Zones 1 and 2, IIC T5 and T6 Group (Gas) and in Zones 21 and 22, IIIC T100°C and T85°C Group (Dust)
- Marine Certification: Lloyd's Register Marine Type Approval
- AISI 316L stainless steel construction
- External shot peened and electro-polished surfaces
- Camera Full HD 1080p, 30x, 60fps
- Minimum Illumination:
  - Colour: 0.006lx
  - B/W: 0.0006lx



Size (WxHxD): 51 x 41 x 12 mm Weight: 8.5 kg

2310131023

### DS-2DY9236I-CWX IP Explosion-Proof Camera

- 1/1.8" progressive scan CMOS
- Up to 1920 × 1080@30fps resolution
- 36× optical zoom, 16× digital zoom
- 120 dB WDR, HLC, BLC, 3D DNR, Defog, EIS, Regional Exposure, Regional Focus
- Up to 150 m IR distance
- Support H.265+/H.265 video compression
- Explosion-proof
- IP-68



Size (WxHxD): 445×245×510 mm Weight: 36.7 kg

2310131014

### DS-2XE6222F-IS/316L IP Explosion-Proof Camera

- 1/2.7" Progressive Scan CMOS
- 1920 × 1080 @25fps frame rate
- Housing material: Stainless steel 304 and 316L optional
- 120dB WDR
- 3D DNR
- Up to 30m IR range
- Support H.265+/H.265/H.264+/H.264
- Support 128G on-board storage
- AC100V to 240V/PoE



Size (WxHxD): 202 × 174 × 172 mm Weight: 7.34 kg

2310131016

### DS-2XE6422FWD-IZHRS IP Explosion-Proof Bullet Camera

- Up to 2 MP high resolution
- 120dB Wide Dynamic Range
- Lens, 2.8 to 12mm and 8 to 32 mm optional
- H.265, H.265+, H.264, H.264+
- Three video streams
- Behavior analyses, exception detections, statistics and face detection
- Support on-board storage, up to 128 GB
- IR range 80 m for 2.8 to 12 mm lens
- Wiper
- Power supply: 100 VAC to 240 VAC and PoE (802.3at, class 4)
- IP-68



Size (WxHxD): 494 × 169 × 308 mm Weight 17.8 kg

2310131018

### MMX2CAZA IP Explosion-Proof Camera

- Certifications for use in Zones 1 and 2, IIB T6 or T5 Group (Gas) and in Zones 21 and 22, IIIC T85°C or T100°C Group (Dust)
- AISI 316L stainless steel construction
- Supports for ceiling, wall and parapet installation supplied
- Camera Full HD 1080p, 3x or 10x Day/Night
- Video compression H.264/AVC, MJPEG, JPEG and MPEG4
- Up to 3 simultaneous video streams
- 4m preinstalled armoured multipolar cable with cable gland
- Power supply: 24Vdc/24Vac, PoE+
- IP-66/IP-67/IP-68/IP-69



Size (WxHxD): 64x20.8x59 mm Weight 11 kg

# Master Clock System

Marine Master Clock is the ideal solution for distribution of both Local and UTC time on board ships.

The Master Clock is equipped with several outputs and inputs for control of Slave Clocks as well as distribution of time to computers and other equipment needing the correct time. The four Slave Clock outputs can be individually programmed for different types of clocks. External radio receivers / time synchronisation sources can be connected when higher accuracy is needed.

For control and regulation of various energy consumers such as electrical striking plates, buzzers for pause signalling etc., the master Clock has a built-in yearly programmer with two relay outputs. The Master Clock is equipped with 10 buttons and a 2 x 16 character LCD. To facilitate the change of time zones, two of the buttons are dedicated to this purpose. A light dimmer makes it possible to adjust the background-illumination to the ambient light level.

## Features

- Accuracy +/- 0.1 sec./24 hours
- Wide range of different slave clocks (digital, IP-65, Ex-proof)
- Easy cabling and calibration
- Accessories and options like radio or satellite
- Signal receivers, RS232C/RS485 interface
- Alarm outputs, etc.
- Automatic summer/winter time change-over
- All units based on TCM

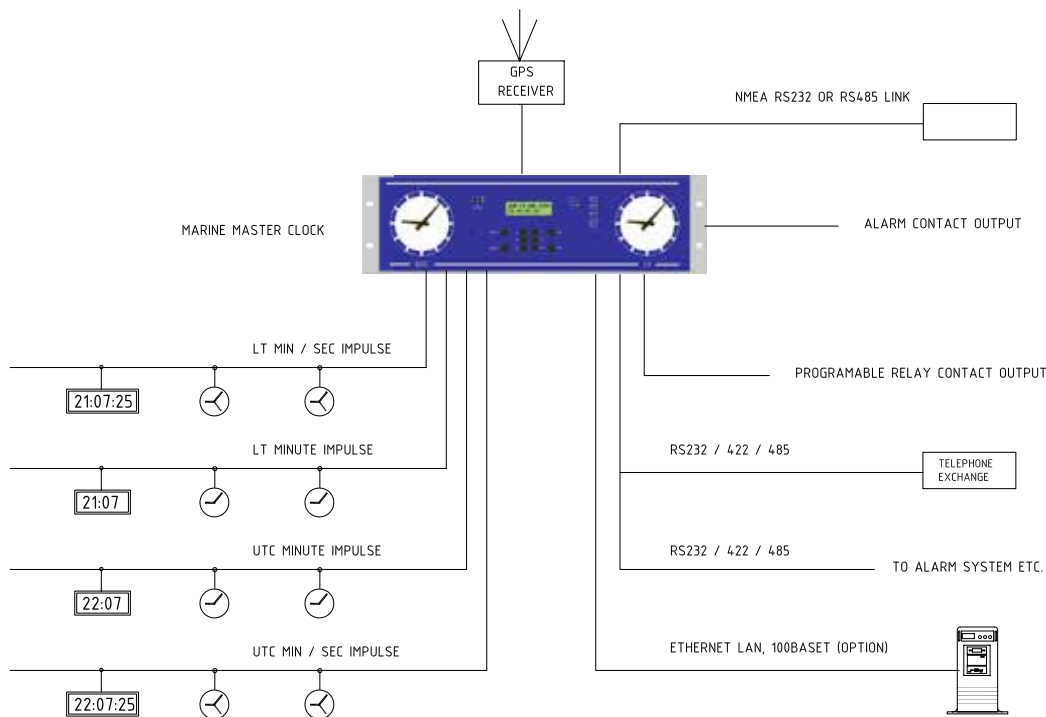

# Master Clock Units



3005050028

## 70000 123378-01 Marine Master Clock

- Accuracy +/- 0.1 sec./24 hours
- Wide range of different slave clocks (digital, Ex-proof)
- Easy cabling and calibration
- Accessories and options like radio or satellite
- Signal receivers, RS232C/RS485 interface
- Alarm outputs, etc.
- Automatic summer-winter time change-over



Size (WxHxD): 483 x 133 x 299 mm Weight: 5.6 kg

Additional Information: IP-20

3005050029

## 70000L 123378-11 Marine Master Clock with Network Time Server

- LAN Connection
- Same features as 70000



Size (WxHxD): 483 x 133 x 299 mm

Weight: 5.6 kg

Additional Information: IP-20

3005050031

## 122980-00 GPS Receiver For Master Clock 70000 & 70000L

- Used for time synchronization of master clocks 70000 and 70000L
- Plastic housing



Size (WxHxD): 110 x 110 x 65 mm Weight: 0.3 kg

Additional Information: IP-65

2310601000

## 2031580-10 Slave Clock, 300mm, TCM

- Anodised aluminium housing and black hour and minute hands. The hands are protected by a convex glass and the clock is to be surface-mounted
- DCF format with time zone adjustment
- 2-wire bus connection with power and serial time code



Size (ØxD): 307 x 58 mm Weight: 0.95 kg

Additional Information: IP-44 surface when mounted  
2310601001 2031584-10 slave clock 300mm, 3 hands TCM

2310601010

## 2021580-10 Slave Clock, 230mm, TCM

- Anodised aluminium housing and black hour and minute hands. The hands are protected by a convex glass and the clock is to be surface-mounted
- DCF format with time zone adjustment
- 2-wire bus connection with power and serial time code



Size (ØxD): 230 x 58 mm Weight: 0.85 kg

Additional Information: IP-44 surface when mounted

2310601020

## 5133580-10 Slave Clock 300mm, TCM, Watertight

- Slave clock for outdoor purposes.
- Casing of stainless steel and acrylic front cover
- DCF format with time zone adjustment
- 2-wire bus connection with power and serial time code



Size (ØxD): 357 x 115 mm Weight: 1.15 kg

Additional Information: IP-65

2310601030

### 6431580-10 Double Faced Slave Clock, 300mm, TCM

- Anodised aluminium housing and black hour and minute hands. The hands are protected by a convex glass and the clock is to be wall mounted
- DCF format with time zone adjustment
- 2 wire bus connection w/ power and serial time code



Size (ØxDxL): 300 x 120 x 435 mm Weight: 3.0 kg

Additional Information: IP-44 Clock for wall mounting

2310601035

### 170130-10 Slave Clock, TCM

- The clock is equipped with an adjustable background light and has black hour and minute hands. The hands are protected by a plain acrylic glass
- DCF format with time zone adjustment
- 2 wire bus connection w/ power and serial time code



Size (WxHxD): 144 x 144 x 70mm Weight: 0.65 kg

Additional Information: Clock for console mounting

2310601025

### 170170-00 Dual Face Slave Clock, TCM

- The housing is an anodised silver profile with a front cover of plexiglass
- It is generally for recessed wall / surface-mounting
- DCF format with time zone adjustment
- 2 wire bus connection w/ power and serial time code



Size (WxHxD): 370 x 150 x 65 mm Weight: 2.0 kg

Additional Information: 9011509001 170170-00-RS Dual face Radio slave clock with Radio Silence

2310601060

### 170155-00 Decorative Slave Clock, 300mm, TCM

- Hands and hour marks in brass
- DCF format with time zone adjustment
- 2 wire bus connection w/ power and serial time code



Size (Ø): 300 mm

Additional Information: Clock for surface mounting

2310601040

### 190000-05 Digital Clock, Lumex 5, Red, TCM

- Digit height 50 mm
- DCF format with time zone adjustment
- 2 wire bus connection w/ power and serial time code
- Light intensity of the digits adjustable by a dimmer control
- Power 230V AC



Size (WxHxD): 250 x 96 x 50 mm Weight: 0.5 kg

Additional Information: IP-22

2310601045

### 190020-05 Digital Clock, Lumex 7, Red, TCM

- Digit height 70 mm
- DCF format with time zone adjustment
- 2 wire bus connection w/ power and serial time code
- Light intensity of the digits adjustable by a dimmer control
- Power 230V AC



Size (WxHxD): 325 x 120 x 50 mm Weight: 0.8 kg

Additional Information: IP-22

# Wireless Communication

<b>Two-Way Radio Solution</b>	<b>73</b>
<b>TETRA Radios</b>	<b>73</b>
<b>VHF &amp; UHF Radios</b>	<b>75</b>
<b>Repeaters</b>	<b>78</b>
<b>IP DECT Solution</b>	<b>79</b>
<b>IP DECT Base Stations &amp; Handsets</b>	<b>80</b>





# TWO-WAY RADIO SOLUTION

**Marine Vessels**

**Semi-Submersible Rigs**

**Jack-Up Rigs**

**Accommodation Platforms**

**Refineries**

**Oil & Chemical Tankers**

## TETRA Radios



### MTP3500xx

#### MTP3500

##### TETRA Portable Radio

- Frequency Band (MHz): 350-470
- Transmitter RF Power: Class 3L (1.8W) / Class 4 (1W)
- Receiver Static Sensitivity (dBm): -116 minimum, -118 typical
- Receiver Dynamic Sensitivity (dBm): -107 minimum, -109 typical
- Operating Temperature (°C): -30 to +60
- Storage Temperature (°C): -40 to +85
- Humidity: ETSI 300 019-1-7 Class 7.3E
- Dust and Water: IP-65, IP-66, IP-67



Size (HxWxD): 124x53x33.5 mm Weight: 280 g

### MTP3550xx

#### MTP3550

##### TETRA Portable Radio

- Frequency Band (MHz): 350-470
- Transmitter RF Power: Class 3L (1.8W) and Class 4 (1W)
- Receiver Static Sensitivity (dBm): -116 minimum, -118 typical
- Receiver Dynamic Sensitivity (dBm): -107 minimum, -109 typical
- Keypad: Full
- Operating Temperature (°C): -30 to +60
- Storage Temperature (°C): -40 to +85
- Humidity: ETSI 300 019-1-7 Class 7.3E
- Dust and Water: IP-65, IP-66, IP-67



Size (HxWxD): 124x53x33.5 mm Weight: 280 g

**MTP6650****MTP6650****TETRA Portable Radio**

- Frequency Band (MHz): 350-470
- Transmitter RF Power: Class 3 (nom. 3W), Class 3L (nom. 1.8W) and Class 4 (nom. 1W)
- Receiver Static Sensitivity (dBm): -116 minimum, -118 typical
- Receiver Dynamic Sensitivity (dBm): -107 minimum, -109 typical
- Operating Temperature (°C): -30 to +60
- Storage Temperature (°C): -40 to +85
- Humidity: ETSI 300 019-1-7 Class 7.3E
- Dust and Water: IP-67, IP-66 and IP-65 per IEC 60529
- Shock, drop and vibration: ETSI 300 019-1-7 Class 5M3



Size (HxWxD): 132x59x34 mm Weight: 292 g

**MTP8500xx****MTP8500EX****TETRA Portable ATEX Radio**

- Gas: II 2G Ex ib IIC T4 Gb
- Dust: Class II 2D Ex ib IIIC T90°C Db
- Triple Certification: ATEX, IEC Ex, FM
- Frequency Band (MHz): 350-470
- Transmitter RF Power class 3L & class 4
- Audio Power: >1.2W Integrated audio howling suppression
- Operating Temperature (°C): -30 to +55
- Storage Temperature (°C): -40 to +85
- Humidity: ETS 300-019-1-7 Class 7.3E, MIL STD 810 D, E, F, G
- Dust and Water: IP-64, IP-65, IP-66 & IP-67 per IEC-60079-0:2011 & IEC-60529
- Shock, drop and vibration: ETS 300-019 1-7 class 5M3, MIL-STD 810 D/E/F/G



Size (HxWxD): 145x57x40 mm Weight: 440 g

**MTP8550xx****MTP8550EX****TETRA Portable ATEX Radio**

- Gas: II 2G Ex ib IIC T4 Gb
- Dust: Class II 2D Ex ib IIIC T90°C Db
- Triple Certification: ATEX, IEC Ex, FM
- Frequency Band (MHz): 350-470
- Transmitter RF Power class 3L & class 4
- Audio Power: >1.2W Integrated audio howling suppression
- Operating Temperature (°C): -30 to +55
- Storage Temperature (°C): -40 to +85
- Humidity: ETS 300-019-1-7 Class 7.3E, MIL STD 810 D, E, F, G
- Dust and Water: IP-64, IP-65, IP-66 & IP-67 per IEC-60079-0:2011 & IEC-60529
- Shock, drop and vibration: ETS 300-019 1-7 class 5M3, MIL-STD 810 D/E/F/G



Size (HxWxD): 145x57x40 mm Weight: 440 g

**MTM5400xx****MTM5400****TETRA Mobile Radio**

- Transmitter RF Power: adjustable to Class 2 (10W), Class 2L (5.6W), Class 3 (3W)
- Receiver Static Sensitivity (dBm): -114 minimum, -116 typical
- Receiver Dynamic Sensitivity (dBm): -105 minimum, -107 typical
- Operating Temperature (°C): -30 to +60
- Storage Temperature (°C): -40 to +85
- Dust and Water: IP-54 (cat. 2)
- Environmental Specification: MIL STD 810, ETSI 300-019-1-5 class 5.2 and 5M3
- Voltage Range: 10.8 to 15.6 V DC
- Current consumption (A, typ) at 10W: Idle 0.5, RX 1, TX 1.2
- AIE Algorithms: TEA1, TEA2, TEA3



Size (HxWxD): 45x170x169 mm Weight: 1 kg

**MTM5500xx****MTM5500****TETRA Mobile Radio**

- Transmitter RF Power: adjustable to Class 2 (10W), Class 2L (5.6W), Class 3 (3W)
- Receiver Static Sensitivity (dBm): -114 minimum, -116 typical
- Receiver Dynamic Sensitivity (dBm): -105 minimum, -107 typical
- Operating Temperature (°C): -30 to +60
- Storage Temperature (°C): -40 to +85
- Dust and Water: IP-54 (cat. 2)
- Environmental Specification: MIL STD 810, ETSI 300-019-1-5 class 5.2 and 5M3
- Voltage Range: 10.8 to 15.6 V DC
- Current consumption (A, typ) at 10W: Idle 0.5, RX 1, TX 1.2
- AIE Algorithms: TEA1, TEA2, TEA3



Size (HxWxD): 45x170x169 mm Weight: 1 kg

# VHF & UHF Radios



3550

## SAILOR SP3550 Portable UHF Radio

- Dual Watch, Tri Watch and Scanning
- Robust design
- Waterproof (IP-67)
- Large display
- Clear sound
- Large tactile buttons
- Ribbed grip
- Interface to external accessories



Size (HxWxD): 130.3 x 55.2 x 37.2 mm Weight: 393g

3560

## SAILOR SP3560EX Portable UHF ATEX Radio

- Dual Watch, Tri Watch and Scanning
- Robust design
- Waterproof (IP-67)
- Large display
- Clear sound
- Large tactile buttons
- Ribbed grip
- Interface to external accessories



Size (HxWxD): 130.3 x 55.2 x 37.2 mm Weight: 393g

3965

## SAILOR 3965 Portable UHF Fire Fighter Radio

- Heavy-duty IP-67 portable UHF radio
- ATEX Class II 2 G Ex ib IIB T4
- IEC 60945 maritime approved
- Designed and built for SOLAS Chapter II-2
- UHF frequency for optional coverage below deck
- Continuous Tone Coded Squelch System (CTCSS) for secure group communications
- Large tactile buttons for easy operation



Size (HxWxD): 209 x 66 x 55 mm Weight: 393g

44\_MDH56

## DP4400E MOTOTRBO Portable Digital Radio

- VHF (136-174MHz), UHF (403-527MHz)
- 32 channels
- Large, textured push-to-talk button
- 3 programmable buttons to improve ease-of-use and increase operator efficiency
- Tri-color LED for clear visual feedback on radio operating status
- IP-57



Size (HxWxD): 130.3 x 55.2 x 37.2 mm Weight: 393g

44\_MDH5601

## DP4401E MOTOTRBO Portable Digital Radio

- VHF (136-174MHz); 300R1 (300-360MHz); 300R2 (350-400MHz); UHF (403-527MHz)
- 32 channels
- Large, textured push-to-talk button for ease of use
- 3 programmable buttons to improve ease-of-use and increase operator efficiency
- Tri-color LED for clear visual feedback on radio operating status
- Emergency button



Size (HxWxD): 130.3 x 55.2 x 37.2 mm Weight: 393g

**44\_MDHxxx****DP4401 EX MOTOTRBO**  
**Portable Digital ATEX Radio**

- VHF (136-174MHz), UHF1 (403-470MHz)
- 32 channels
- Large, textured push-to-talk button for ease of use
- 3 programmable buttons
- Tri-color LED
- IP-67 ingress protection (also certified to the highest ingress protection available under ATEX/ IECEx test conditions - IP-64)



Size (HxWxD): 138.5 x 57 x 38 mm Weight: 455.5 g

**46\_MDHx****DP4600E MOTOTRBO**  
**Portable Digital Radio**

- VHF (136-174MHz), UHF (403-527MHz)
- 1000 channels
- Large Full-colour, 5-line display - operating in Day or Night mode for easy viewing
- Tri-colour LED for clear visual feedback on radio operating status
- Easy-to-use menu navigation keys enable intuitive user interface
- Large, textured push-to-talk button for ease of use



Size (HxWxD): 130 x 55 x 39 mm Weight: 405 g

**46\_MDHxx****DP4601E MOTOTRBO**  
**Portable Digital Radio with GPS**

- VHF (136-174MHz), UHF (403-527MHz)
- 1000 channels
- Large Full-colour, 5-line display - operating in Day or Night mode for easy viewing
- Tri-colour LED for clear visual feedback on radio operating status
- Easy-to-use menu navigation keys enable intuitive user interface
- Large, textured push-to-talk button for ease of use



Size (HxWxD): 130 x 55 x 39 mm Weight: 405 g

**48\_MDHx****DP4800E MOTOTRBO**  
**Portable Digital Radio**

- VHF (136-174MHz), UHF (403-527MHz)
- 1000 channels
- Large Full-colour, 5-line display - operating in Day or Night mode for easy viewing
- Tri-colour LED for clear visual feedback on radio operating status
- Full Alphanumeric Keypad enables flexible radio operation and text messaging
- Large, textured push-to-talk button for ease of use



Size (HxWxD): 130 x 55 x 39 mm Weight: 405 g

**48\_MDHxx****DP4801E MOTOTRBO**  
**Portable Digital Radio with GPS**

- VHF (136-174MHz); 300R1 (300-360MHz); 300R2 (350-400MHz); UHF (403-527MHz)
- Hardware options for Standard, MPT or ConnectPlus
- 1000 channels
- Large Full-colour, 5-line display - operating in Day or Night mode for easy viewing
- Tri-colour LED for clear visual feedback on radio operating status
- Full Alphanumeric Keypad



Size (HxWxD): 130 x 55 x 39 mm Weight: 405 g

**48\_MDHxxx****DP4801EX MOTOTRBO**  
**Portable Digital ATEX Radio**

- VHF (136-174MHz), UHF1 (403-470MHz)
- 1000 channels
- Large Full-colour, 5-line display – operating in Day or Night mode for easy viewing
- Tri-colour LED for clear visual feedback on radio operating status
- IP-67 ingress protection (also certified to the highest ingress protection available under ATEX/ IECEx test conditions - IP-64)
- Full Alphanumeric Keypad



Size (HxWxD): 138.5 x 57 x 40 mm Weight: 482.5 g



## 1\_TP9000EX

### TP9000EX Portable ATEX Radio

- Intrinsically Safe - ATEX
- VHF & UHF
- IP-67 Waterproof
- Power Output: 2 Watts
- CTCSS, 5-TONE, CCIR, ZVEI, EEA & EIA
- Man-down function
- 16 Channels
- PC programmable
- Long operational time  
- 3000 mAh battery



Size (HxWxD): 137 x 64 x 31 mm Weight: 250 g

## MDM28xx

### DM4400E MOTOTRBO Mobile Digital Radio

- UHF1 (403-470MHz) LP/HP, VHF (136-174MHz) LP/HP, UHF2 (450-527MHz) LP-HP
- Channel Spacing 12.5/20/25kHz (UHF/VHF), 12.5/25kHz (UHF2)
- IP-54 rated
- 99 channels
- 2-digit numerical display
- 3-watt built-in loudspeaker for clear audio
- Rugged front & rear accessory connectors
- Accessory connector supports USB interface
- Large, easy-to-use volume/channel knob
- 4 programmable buttons
- Multi-colored LED indicators



Size (HxWxD): 53 x 175 x 206 mm Weight: 1.8 kg

## MDM28xxx

### DM4401E MOTOTRBO Mobile Digital Radio with GPS

- UHF1 (403-470MHz) LP/HP, VHF (136-174MHz) LP/HP, UHF2 (450-527MHz) LP-HP
- Channel Spacing 12.5/20/25kHz (UHF/VHF), 12.5/25kHz (UHF2)
- IP-54 rated
- 99 channels
- 2-digit numerical display
- 3-watt built-in loudspeaker for clear audio
- Rugged front & rear accessory connectors
- Accessory connector supports USB interface
- Large, easy-to-use volume/channel knob
- 4 programmable buttons
- Multi-colored LED indicators
- Integrated GNSS (GPS and GLONASS)



Size (HxWxD): 53 x 175 x 206 mm Weight: 1.8 kg

## MDM28xxx

### DM4600E MOTOTRBO Mobile Digital Radio

- UHF1 (403-470MHz) LP/HP, VHF (136-174MHz) LP/HP, UHF2 (450-527MHz) LP-HP
- Channel Spacing 12.5/20/25kHz (UHF/VHF), 12.5/25kHz (UHF2)
- IP-54 rated
- 1000 channels
- 4-line alphanumeric numerical display & icons
- 3-watt built-in loudspeaker for clear audio
- Rugged front & rear accessory connectors
- Accessory connector supports USB interface
- Large, easy-to-use volume/channel knob
- 4 programmable buttons
- Multi-colored LED indicators



Size (HxWxD): 53 x 175 x 206 mm Weight: 1.8 kg

## MDM28xxxx

### DM4601E MOTOTRBO Mobile Digital Radio with GPS

- UHF1 (403-470MHz) LP/HP, VHF (136-174MHz) LP/HP, UHF2 (450-527MHz) LP-HP
- Channel Spacing 12.5/20/25kHz (UHF/VHF), 12.5/25kHz (UHF2)
- IP-54 rated
- 1000 channels
- 4-line alphanumeric numerical display & icons
- 3-watt built-in loudspeaker for clear audio
- Rugged front & rear accessory connectors
- Accessory connector supports USB interface
- Large, easy-to-use volume/channel knob
- 4 programmable buttons
- Multi-colored LED indicators
- Integrated GNSS (GPS and GLONASS)



Size (HxWxD): 53 x 175 x 206 mm Weight: 1.8 kg

## 6110

### SAILOR 6110 mini-C GMDSS System

- Integral part of a vessel's communication system featuring true triple functionality as it safely handles all GMDSS, SSAS and LRIT operation on board.
- First ever approved touch screen terminal for GMDSS use
- External storage via SD card or USB disk
- Innovative approach to cabling for simple networking and expansion
- Accurate, reliable 50 channel GPS module that is also Galileo ready



Diameter: 170.5 mm Height: 145 mm Weight: 1.1 kg

## 6222 Mobile

### SAILOR 6222

#### VHF DSC Mobile Radio

- Unique SAILOR Replay (240 sec.) of incoming communication
- High quality display, ideal for night and day vision
- Powerful 6W loudspeaker
- Intuitive and easy to operate menu structure
- Large tactile buttons and wheelknobs for easy operation
- Popular SAILOR handset



Diameter: 170.5 mm Height: 95 mm Weight: 2.5 kg

## 6300 Mobile

### SAILOR 6300

#### MF/HF Mobile Radio

- SAILOR Replay – 240 seconds
- High quality graphical display - ideal night and day vision
- 6W internal loudspeaker for excellent sound quality
- Improved, intuitive and easy to operate menu structure
- Unique, next generation radiotelex software
- Multiple control units
- 150W-250W-500W versions
- ThraneLINK
- Tune cache. Fast tuning to frequencies previously used



Size (HxWxD): 107 x 241 x 107 mm Weight: 3.3 kg

## Repeaters

### MTR3000Exx

#### MTR3000 Digital Repeater

- UHF1 (403-470MHz) and VHF1 (136-174MHz)
- Integrated 8-100W Power Amplifier
- 1.5 PPM Frequency Stability
- Switching power supply functions over a wide range of voltages and frequencies
- 6.25e, 12.5 or 25kHz programmable channel spacing



Size (HxWxD): 133 x 483 x 419 mm Weight: 19 kg

### SLR5500xx

#### SLR5500 Digital Repeater

- VHF (136-174MHz); UHF1 (400-470MHz), 300R1 (300-360MHz)
- 64 channels capacity
- 1-50 Watts power
- 100% duty cycle at full power
- 1U form factor
- No self quieting frequency requirements
- Maritime compliancy for UHF1 model when installed with an AC Filter



Size (HxWxD): 44 x 483 x 370 mm Weight: 8.6 kg

### SLR8000xx

#### SLR8000 Base Station / Repeater

- VHF (136-174MHz), UHF1 (400-470MHz)
- 64 channels capacity
- 1-100 Watts power
- 100% duty cycle at full power
- No self quieting frequency requirements



Size (HxWxD): 89 x 483 x 438 mm Weight: 14 kg





## IP DECT Solution

DECT (Digitally Enhanced Cordless Telecommunications) is a European standard developed by ETSI for digital cordless phones, and it has a dedicated frequency range. The system consists of single-cell wireless phones connected through base stations to a DECT server, usually interfaced to a PBX and/or external telephone lines.

The DECT platform can also serve as a mobile platform for receiving and distributing alarms and messages. The frequency range is reserved exclusively for voice communication applications, and therefore, is less likely to experience interference from other wireless devices such as baby monitors and wireless networks. The new generation DECT (also known as CAT-iq) also supports wideband audio.

Zenitel has extensive experience with the deployment of DECT solutions in harsh environments and has developed special solutions for these areas.

# IP DECT Base Stations & Handsets



- **System 400**  
Limited radio coverage with 1 base station and upto 3 repeaters
- **System 6500**  
Wide area coverage with upto 255 base stations  
Centralized radio planning, configuration and monitoring
- Base station radio coverage  
-Indoor - max 50m  
-Outdoor – max 150m
- DECT repeaters can be added to extend radio coverage
- Robustness even in hostile radio environments - using Dynamic Channel Selection and Allocation
- Encrypted radio communication
- Cost efficient implementations of system components
- Special purpose handset for marine usage – office, rough and Ex

2211010200

## KWS400 IP DECT Server & Base Station

- Integrated in ACM solution
- Stand-alone with 1 base station and up to 3 repeaters
- Up to 3 base stations can be connected (require additional license)
- Up to 12 handset
- Base station radio coverage  
- Indoor - max 50m  
- Outdoor – max 150m
- DECT repeaters can be added to extend radio coverage
- Robustness even in hostile radio environments - using Dynamic Channel Selection and Allocation
- Encrypted radio communication
- Cost efficient implementations of system components
- Special purpose handset for marine usage – office, rough and EX
- Powered by PoE



Size Base 300 (WxHxD): 100 x 100 x 38 mm  
Weight: 0.12 kg

2211000150

## KWS6500 IP DECT Server 19" 1HU 110-240 VAC

- Integrated part in ACM solution
- Wide area coverage with upto 255 base stations
- Up to 4096 handsets
- Centralized radio planning, configuration and monitoring
- Base station radio coverage - Indoor - max 50m-  
Outdoor – max 150m
- DECT repeaters can be added to extend radio coverage
- Robustness even in hostile radio environments - using Dynamic Channel Selection and Allocation
- Supports handover and roaming between base stations
- Encrypted radio communication
- Cost efficient implementations of system components
- Special purpose handset for marine usage – office, rough and Ex



Size (WxHxD): 440 x 44 x 199 mm Weight: 2.35 kg

2211000620

## IP DECT Base Station for KWS6500

- Base station radio coverage: max 50 m indoor and max 150 m outdoor
- DECT repeaters can be added to extend radio coverage
- Powered by PoE
- 11 speech channels



Size (WxHxD): 100 x 100 x 38 mm Weight: 0.12 kg

2211050107

## DECT Repeater

- 4 Channels, Max 3 per Base Station
- Wireless – no cabling needed
- Create coverage in a remote area
- Expand coverage in a single cell solution
- Increase coverage in hot spot areas
- Used with all KWS Servers



Size (WxHxD): 100 x 100 x 38 mm Weight: 0.12 kg

2211000645

## SMART1-AP Multicell Base Station

- CAT-iq certified multicell base station
- No need for centralized server
- The system scales up and supports from 1 to 512 bases in the same network without licenses
- Able to support up to 1000 registered handsets
- The base-stations uses complete DECT MAC protocol layer and IP media stream audio encoding
- Supports up to 8 simultaneous voice channels per base station including advanced alarm features
- Based on PoE interface, easy to install on LAN
- Maximum coverage and reduced installation time
- Seamless handover, automatic configuration
- SIP as media protocol with IP PBX or SIP server
- CAT-iq delivers high-quality HD audio
- Built-in automatic load balancing, failover and redundancy directly into the system design without the need for licenses or server solutions



Size (WxHxD): 140x145x37 mm Weight: 300 g

2211000606

### IP DECT Base Station

- Cabinet with heater and thermostat
- Designed for outdoor cold environment
- PoE for base station and 230 VAC for heater
- 115V AC on request
- Prepared with terminals and cable glands



Size (WxHxD): 430 x 330 x 200 mm Weight: 8.0 kg

2210020001 / 2210020003

### Alarm Module for IP DECT Alarm Server - 8 Alarms / ESPA 4.4.4

- Communication RS485
- Capacity 8 Opto inputs
- 8 relay inputs, Expandable I/O
- IP DECT, Printer Log, Log File
- 2210020001: 8 Alarms
- 2210020003: ESPA 4.4.4 inputs



Size (WxHxD): 120 x 30 x 75 mm Weight: 0.2 kg

Additional Information: Module needed when more than 8 alarms is requested

2210020000

### IP DECT Alarm Server with 8 Alarm Inputs

- Complete messaging and alarm solution
- Time-saving operations
- Increased operational safety
- Efficient management of handsets
- Easy to use, install and configure
- Integrated into Vingtor-Stentofon ACM IP DECT Solution
- Expandable to maximum 50 users (Basic License)



Size (HxWxD): 65 x 213 x 107 mm Weight: 3.8 kg

2211000660

### BS-750 DECT VoIP Base Station

- Up to 5 concurrent calls per DECT system
- Supports a range of up to 300 meters outdoors and 50 meters indoors
- 3-way voice conferencing, full HD audio, integrated PoE
- TLS and SRTP security encryption
- Automated provisioning
- Pairs with up to 5 DCT-720 DECT handsets



Size (HxWxD): 28.5 x 130 x 90 mm Weight: 143 g

2211100155

### DCT-720 DECT Cordless Handset

- Up to 10 SIP accounts per handset
- 3-way voice conferencing
- Full HD audio
- 3.5 mm headset jack
- DECT authentication & encryption technology to protect calls and account
- Automated provisioning



Size (HxWxD): 155 x 50 x 26 mm Weight: 138 g

2211100516

### C-3105i DECT Handset Rough

- Water and dust resistant according to IP-65
- Large and clear 1.8" colour display
- Built-in vibrator for noisy environments or discretion is required
- High battery capacity – Li-ion battery
- 2.5mm jack for headset
- Loudspeaking and handsfree function
- Battery and belt clip included
- Personalized softkey
- 10 last alarms are stored in the handset, up to 32 characters in each message



Size (WxHxD): 152 x 53 x 27 mm Weight: 138 g

Additional Information: IP-65

2211100517

### C-3110i DECT Handset Rough

- Water and dust resistant according to IP-65.
- Large 1.8" display, 7 lines with color-coding
- Dynamic display with up to 16 characters in each line, each message can contain 198 characters.
- Built-in vibrator for noisy environments.
- High battery capacity – Li-ion battery.
- 2.5 mm jack for headset.
- Loudspeaking and handsfree function.
- Battery and belt clip included.
- Large dedicated alarm button.
- Extra function key on the right side for alarm acknowledge, send soft alarms or call colleagues.
- Supports advanced alarm handling



Size (WxHxD): 152 x 53 x 27 mm Weight: 138 g

Additional Information: IP-65

2211100518

### C-3110i-POS DECT Handset Rough with Positioning

- Positioning option allows monitoring and tracking of the DECT handset position in case of incidents.
- Water and dust resistant according to IP-65.
- Large 1.8" display, 7 lines with color-coding line
- Built-in vibrator for noisy environments
- High battery capacity – Li-ion battery.
- 2.5 mm jack for headset.
- Loud speaking and hands free function.
- Battery and belt clip included.
- A large dedicated alarm button.
- Extra function key on right side for alarm acknowledge, send soft alarms or call colleagues.
- Supports advanced alarm handling



Size (WxHxD): 152 x 53 x 27 mm Weight: 138 g

Additional Information: IP-65

2211100519

### C-3115i DECT Handset Rough

- Water and dust resistant according to IP-65.
- Large 1.8" display, 7 lines with color-coding
- Dynamic display with up to 16 characters.
- Built-in vibrator for noisy environments.
- 2.5 mm jack for headset.
- Loud speaking and hands free function.
- Battery and belt clip included.
- A large dedicated alarm button.
- Extra function key on the right side for alarm acknowledge, send soft alarms or call colleagues.
- Supports advanced alarm handling.
- Equipped with man down and motion alarm, for monitoring of movement or non movement.
- Pull cord alarm for protection against theft, personal attack or for use in distress situations.



Size (WxHxD): 152 x 53 x 27 mm Weight: 138 g

Additional Information: IP-65

2211100520

### C-3115i-POS DECT Handset Rough with Positioning

- Positioning option allows monitoring and tracking of the DECT handset position in case of incidents.
- Large 1.8" display, 7 lines with color-coding
- Dynamic display with up to 16 characters.
- Built-in vibrator for noisy environments.
- 2.5 mm jack for headset.
- Loud speaking and hands free function.
- A large dedicated alarm button.
- Supports advanced alarm handling.
- Equipped with man down and motion alarm, for monitoring of movement or non movement.
- Pull cord alarm for protection against theft, personal attack or for use in distress situations.



Size (WxHxD): 152 x 53 x 27 mm Weight: 138 g

Additional Information: IP-65

2211100521

### SMART1-SM-HS Android based DECT Smartphone with WiFi

- Top display for displaying alarms and messages without the need to pick up the phone
- Dedicated Alarm/Emergency button and precise indoor location
- Push-To-Talk for quick and easy communication
- Physical keypad for on/off hook and menu options
- WiFi for data, video, apps, alarm, voice
- Bluetooth Low Energy applications
- Near Field Communication for access control
- Precise Indoor Positioning via RFID, NFC, BLE, DECT, WiFi
- High Definition Audio (40-7000 Hz)



Size (HxWxD): 135 x 66 x 15 mm Weight: 195 g

2211100522

### SMART1-SP-HS DECT Handset

- 2" Display
- High Definition (HD) Audio G.722 (40-7000 Hz)
- DECT encryption: EN 300 444 and EN 300 700
- Wide band speaker phone
- Easy to change battery
- Local telephone book with 100 entries
- Central phonebook with 3000 entries
- Headset connector 3.5 mm
- Upgradable "over the air"
- Vibrator
- Polyphonic ring tones



Size (HxWxD): 140 x 48 x 25 mm Weight: 136 g

# Common Equipment

<b>Loudspeakers</b>	<b>84</b>
<b>Accommodation Loudspeakers</b>	<b>84</b>
<b>Outdoor &amp; Engine Room Loudspeakers</b>	<b>86</b>
<b>Ex Area Loudspeakers</b>	<b>87</b>
<b>IP Loudspeakers</b>	<b>88</b>
<b>Signal Units</b>	<b>89</b>
<b>UPS - Uninterruptible Power Supply</b>	<b>92</b>

## Loudspeakers

Our range of loudspeakers cater to all marine environments. The range includes loudspeakers that are flush/surface mount, fire retardant, watertight, horn, Ex speakers, and more.

## Signal Units

Different types of rotary lights, signal units, sounders, bells and flashing beacons are used to provide visual call indication in noisy areas.

## UPS - Uninterruptible Power Supply

A range of Uninterruptible Power Supply (UPS) units with extra battery cabinets are available. UPS is available in versions from 600 W to 3500 W, all with battery backup providing power for 30 minutes. If your installation requires even higher UPS capacity, additional units are available on request.

# Loudspeakers



## Loudspeakers Accommodations

- 100V line
- Adjustable power tapplings
- Indoor use

2131000142

### CL-200T-AG Ceiling Speaker with Steel Firedome for Humid Rooms

- Made for marine environment
- Good audio quality
- Steel back box to reduce spread of fire
- Selector on the back to adjust power tapping to accommodate separate room sizes
- Cable glands increase stability of wire connectivity
- Supports loop wiring with 2 x M20 cable glands
- Includes thermal fuse and ceramic terminals
- Aluminum grille and fully painted chassis provides good corrosion properties



Size (Ø x D): 199 x 101 mm Weight: 1.45 kg

Additional Information: IP-55 (from front side only after proper ceiling installation)

2131000138

### CL-200T Ceiling Speaker with Steel Firedome

- Good audio quality
- Steel back box to reduce fire risk and spread
- Spring fasteners and screw holes for vibrating environments
- Spring fasteners only for non-vibrating environments
- Adjustable power tapping to accommodate separate room sizes
- Back box glands increase stability of wire connectivity
- Supports loop wiring with 2 x 20 mm back box glands
- Includes thermal fuse, transformer and supports 100V lines



Size (Ø x D): 199 x 101 mm Weight: 1.45 kg

Additional Information: IP-44

2131000131

### CLMQ-200T Ceiling Speaker

- 6" ceiling speaker delivers high quality sound with a flat frequency response curve
- Suitable for distribution of background music, announcements and voice messages with a high level of intelligibility
- Easily mounted with two spring clamps



Size (Ø x D): 199 x 83 mm Weight: 1 kg

2131000132 / 2131000141

### CL-135T / CL-135T-W/FD Ceiling Speaker

- 5" miniature ceiling speaker for small rooms or where space for mounting speakers is limited
- Robust, yet discreet design
- Easily mounted with two spring clamps
- 2131000132: CL-135T
- 2131000141: CL-135T-W/FD with Fire Dome



Size (Ø x D): 135 x 82 mm Weight: 0.5 kg

2131000133

### CLWT-135T Ceiling Speaker

- Made for demanding environments
- IP-55 Water ingress protection from all sides
- Good audio quality
- Plastic back box
- Spring fasteners and screw holes for vibrating environments
- Spring fasteners only for non-vibrating environments
- Adjustable power tapping to accommodate separate room sizes
- Back box glands increase stability of wire connections
- Loop wiring with 2x20mm backbox glands
- Includes thermal fuse, ceramic terminals and transformer for 100V lines



Size (Ø x D): 136 x 130 mm Weight: 0.6 kg

2131000140

### CLMQ-200-FD Fire Dome

- Fire Dome for CLMQ-200T



2131000205

### VES-561TF Ceiling Speaker Flush-Mounted, 6W

- Flush mounting
- Steel back box to reduce fire risk and spread
- With 100V line transformer
- Adjustable power tapping: 0.5W - 1.5W - 3.0W - 6.0W



Size (Ø x D): 165 x 112 mm Weight: 1.1 kg

2340020016

### SAFE-561IP(T) Voice Alarm Speaker, 6W

- Loudspeaker for voice evacuation and marine installations.
- With 100V line transformer
- Adjustable power tapping
- 0.5W - 1.5W - 3.0W - 6.0W



Size (Ø x D): 169 x 65 mm Weight: 1.3 kg

Additional Information: IP-55

3006100019

### CAR-4TF Wall-Mount Double-Faced Speaker, 4W

- Double faced loudspeaker for accommodation area
- Ideal for P.A. intercom and background music
- With 100V line transformer
- Adjustable power tapping 0.5W - 1.0W - 2.0W - 4.0W



Size (Ø x D): 152 x 90 mm Weight: 1.5 kg

Additional Information: Include cable 1m

3006100032 / 3006100033

### CW-4T / CW-AT/VOF On-Wall Speaker

- Wall loudspeaker for accommodation area
- Ideal for PA intercom and background music
- With 100V line transformer
- Adjustable power tapping: 0.5W - 1.5W - 3.0W - 6.0W
- CW-AT/VOF: with Volume Control & Override



Size (WxHxD): 250 x 170 x 88 mm Weight: 1.2 kg

2131000137

### BSWT-6T On-Wall Speaker for Bathroom & Humid Room

- 100V, 6W, IP-65
- Made for marine environment
- Good audio quality
- Corrosion-free plastic enclosure
- Cable entry in the bottom or from the back
- An integrated gasket enables watertight mounting without cable glands when using the rear cable entry
- Adjustable power tapping to accommodate separate room sizes
- Supports loop wiring with double cable entries
- Includes thermal fuse, ceramic terminals and transformer for 100V lines



Size (WxHxD): 133 x 133 x 70.5 mm Weight: 0.7 kg

3006100084

### SAFE-10PTF On-Wall Speaker for Bathroom

- IP-44
- Loudspeaker for voice evacuation and marine installations.
- Specially designed to fit tube light armature
- With 100V line transformer
- Adjustable power tapping
- Suitable for bathroom 1.0W - 2.5W - 5.0W - 10.0W



Size (WxHxD): 206 x 104 x 55 mm Weight: 0.8 kg

## Loudspeakers Outdoor & Engine Room

- 100V line
- Adjustable power tapplings
- Suitable for outdoor areas and engine room

3006090476

### JB-15T Junction Box

- Junction box for loudspeaker type VLS-15TF
- 1 x PG11 & 1 x PG13.5 Blank Plug



Size (WxHxD): 97 x 90 x 58 mm Weight: 0.12 kg

Additional Information: IP-66

2131000206

### VLS-15TF Horn Speaker 15W 100V with Transformer & Fuse

- General purpose 15W horn loudspeaker with transformer and fuse
- Especially suitable for use in industrial sites or tough environments
- To be used together with 100V line amplifier
- With 4 different power tapplings: 2.5W, 5W, 10W and 15W



Size (WxHxD): 253 x 152 x 309 mm Weight: 1.85 kg

Additional Information: IP-66

2131000208

### VLS-30TF Horn Speaker 30W 100V with Transformer

- General purpose 30W horn loudspeaker with transformer for 100V line
- Especially suitable for use in industrial sites or tough environments
- ABS housing and stainless steel bracket ensures good corrosion properties
- With 6 different power tapplings: 5W, 10W, 15W, 20W, 25W, 30W



Size (WxHxD): 315 x 170 x 350 mm Weight: 2.5 kg

Additional Information: IP-66

3006100088

### VML-1520 Horn Speaker, Waterproof

- General purpose 15-Watt, 20-ohm horn loudspeaker
- For use on open deck areas, engine room, etc.
- To be used together with ACM or Talk-Back stations



Size (WxHxD): 250 x 145 x 270 mm Weight: 1.35 kg

Additional Information: IP-67

3006100056

### HP-15TF Horn Speaker, 15W

- General purpose 15 Watt horn loudspeaker
- For use in deck areas, engine room etc.
- With 100V line transformer and fuse
- Adjustable power tapping: 2W - 4W - 7.5W - 15.0W



Size (Ø x D): 200 x 247 mm Weight: 1.7 kg

Additional Information: IP-67

3006100063

### HP-30TF Horn Speaker, 30W

- General purpose 30 Watt horn loudspeaker
- For use in deck areas, engine room etc.
- With 100V line transformer and fuse
- Adjustable power tapping:  
2.0W -3.5W- 7.5W -15.0W -20.0W- 30.0W



Size (Ø x D): 237 x 298 mm Weight: 2.3 kg

Additional Information: IP-67

3006100043

### DST-100 Driver Unit for Horn Speaker

- 100 W driver unit for use together with DH-50 horn speaker
- 100V line transformer
- Suitable for covering large areas.
- Adjustable power tapping:  
7.5W -15.0W  
30.0W - 60.0W - 100W



Size (Ø x D): 128 x 176 mm Weight: 2.5 kg

Additional Information: IP-67

3006100036

### DH-50 Waterproof Horn Speaker

- For use together with driver DST-100
- Suitable for covering large areas
- Fiberglass laminated polyester / RAL 7035



Size (Ø x D): 325 x 345 mm Weight: 3.6 kg

Additional Information: IP-67

## Loudspeakers Ex Area

- ATEX Approved
- 100V line
- Adjustable power tapplings
- Suitable for hazardous areas

2340020006

### CAREx-6T Wall Double-Faced Speaker, ATEX, 6W

- Double faced loudspeaker in aluminium
- For Zone 1 & 2
- Used for cabins, hallways etc. in hazardous areas.
- 100V line transformer
- Adjustable power tapping  
0.3W - 0.5W - 1W - 1.5W - 3W - 6W



Size (HxD): 178 X 145 mm Weight: 3,6 kg

Additional Information: IP-67 (EX-chamber)

2340020015

### BA-56EExeNT Ex Ceiling Speaker

- Ceiling loudspeaker for hazardous areas.
- 100V line transformer
- ATEX approved
- 1 x M20 EExe ATEX approved cable gland and 1 x M20 EExe ATEX approved blind plug.
- Material: Aluminum/RAL 9010
- Adjustable power tapping  
0.3W - 0.5W - 1W - 1.5W - 3W - 6W



Size (ØxD): 220 X 172 mm Weight: 3.0 kg

Additional Information: IP-67 ATEX approved for Zones 1&2

2340110016

### JBP-120EExeN

- Ex Junction box for Ex loudspeakers
- 6 possible M20 entries, earth plate and 2.5 mm Wago terminal.



Size (WxHxD):120 x 47 x 104.5 mm Weight: 0.4 kg

2340020025

### DSP-15 EExmNT 15W Ex Horn Speaker

- Horn speaker in Antistatic Polyamide, black
- For zones 1 & 2
- 100V line transformer
- Adjustable power tapping:  
2W - 4W - 7.5W - 15W
- Ex db IIB+H2 T4



Size (WxHxD):170 x 144 x 207 mm Weight: 2.2 kg

Additional Information: IP-67

2340020012

### DSP-15 EExmNT 25W Ex Horn Speaker

- Horn speaker in Antistatic Polyamide, black
- For zones 1 & 2
- 100V line transformer
- Adjustable power tapping:  
1.5W - 2.5W - 5W - 6.5W - 15W - 25W
- Ex db IIB+H2 T4



Size (WxHxD):170 x 144 x 207 mm Weight: 2.2 kg

Additional Information: IP-67

3006100058

### HP-20EExiiNT Horn Speaker 20W, 100V, Ex Zone 2

- Horn speaker in Antistatic Polyamide.
- For zones 1 & 2
- 100V line transformer
- Adjustable power tapping:  
2W - 3.5W - 7.5W - 15W - 20W



Size (ØxD): 237 x 286 mm Weight: 2.3 kg

Additional Information: IP-67  
Certified according to EN 60079-15

## IP Loudspeakers

- Designed to deliver CCoIP® - Critical Communication over IP
- Ideal for Micro Zone PA and systems that require a limited number of speakers

1023300010

### ELSIR-10C Network Ceiling Loudspeaker, 10W, Ethernet

- Audio Presence - crystal clear audio
- Steel fire dome
- 10W Class D, built-in amplifier
- > 100 dB SPL
- Ideal for Micro Zone PA and systems that require a limited number of speakers
- Each speaker is individually addressable and monitored
- Ideal for speakers installed in remote locations, e.g. roads and railways
- Remote software upgrade and configuration
- Relay output for remote control, e.g. doors, signal lamps, gates
- Powered from the IP network cable using Power over Ethernet (PoE)



**Size (ØxD): 199 x 145,5 mm Weight: 1.4 kg**

Additional Information: 2220040030 Installation kit for IP speakers/TCIS/TFIE/EAPII, cat6A

1023301310

### ELSII-10H Network Horn Loudspeaker, 10W, Ethernet

- Audio Presence - crystal clear audio
- 10W Class D, built-in amplifier
- Dust and water tight
- > 110 dB SPL
- Ideal for Micro Zone PA and systems that require a limited number of speakers
- Each speaker is individually addressable and monitored
- Ideal for speakers installed in remote locations, e.g. roads and railways
- Remote software upgrade and configuration
- Relay output for remote control, e.g. doors, signal lamps, gates
- Powered from the IP network cable using Power over Ethernet (PoE)



**Size (WxHxD): 144x186x207 mm Weight: 1.8 kg**

Additional Information: IP-67  
2220040030 Installation kit for IP speakers/TCIS/TFIE/EAPII, cat6A

# Signal Units



3006102041

## EHS-240 Rotary Light - Orange

- Used in noisy areas to indicate a call
- Can be used with all Industrial Stations or Telephones
- Must use CRB-7 when used on Industrial Telephones
- Equipped with 1m Cable
- 24 VDC, 3A



3006102038

## EHS-24B Rotary Light 24VDC Blue

3006102039

## EHS-24G Rotary Light 24VDC Green

3006102040

## EHS-24K Rotary Light 24VDC Clear

3006102042

## EHS-24R Rotary Light 24VDC Red

**Size (ØxH): 147 x 220 mm Weight: 0.9 kg**

Additional Information: IP-54

3006102036

## EHS-2200 Rotary Light - Orange

- Used in noisy areas to indicate a call
- Can be used with all Industrial Stations or Telephones
- Must use CRB-7 when used on Industrial Telephones
- Equipped with 1m Cable
- 220 VAC



3006102033

## EHS-220B Rotary Light 220VAC Blue

3006102034

## EHS-220G Rotary Light 220VAC Green

3006102035

## EHS-220K Rotary Light 220VAC Clear

3006102037

## EHS-220R Rotary Light 220VAC Red

**Size (ØxH): 147 x 220 mm Weight: 0.9 kg**

Additional Information: IP-54

3006102032

## EHS-1100 Rotary Light 110VAC - Orange

- Used in noisy areas to indicate a call
- Can be used with all Industrial Stations or Telephones
- Must use CRB-7 when used on Industrial Telephones
- Equipped with 1m Cable
- 110 VAC



2340200001

## EHS-110B Rotary Light 110VAC Blue

2340200002

## EHS-110G Rotary Light 110VAC Green

2340200003

## EHS-110K Rotary Light 110VAC Clear

2340200004

## EHS-110R Rotary Light 110VAC Red

**Size (ØxH): 147 x 220 mm Weight: 0.9 kg**

Additional Information: IP-54

2340220003

## L-101-24Y Xenon Strobe - Yellow

- Optical signaling device of rugged design for indoor and outdoor use
- 24 - 28 VDC 300mA



2340220000

## L-101-24R Xenon Strobe, 20-28VDC, Red

2340220002

## L-101-24A Xenon Strobe, 20-28VDC, Amber

2340220004

## L-101-24G Xenon Strobe, 20-28VDC, Green

2340220005

## L-101-24B Xenon Strobe, 20-28VDC, Blue

2340220006

## L-101-24C Xenon Strobe, 20-28VDC, Clear

**Size (WxHxD): 86 x 86 x 83 mm Weight: 0.2 kg**

Additional Information: IP-66

2340220009

## L-101-115Y Xenon Strobe - Yellow

- Optical signaling device of rugged design for indoor and outdoor use
- 115 VAC



2340220007

## L-101-115R Xenon Strobe, 115VAC, Red

2340220008

## L-101-115A Xenon Strobe, 115VAC, Amber

2340220010

## L-101-115G Xenon Strobe, 115VAC, Green

2340220011

## L-101-115B Xenon Strobe, 115VAC, Blue

2340220012

## L-101-115C Xenon Strobe, 115VAC, Clear

**Size (WxHxD): 86 x 86 x 83 mm Weight: 0.2 kg**

Additional Information: IP-66

2340220015

### L-101-230Y Xenon Strobe - Yellow

- Optical signaling device of rugged design for indoor and outdoor use
- 230 VAC



2340220013

L-101-230R Xenon Strobe, 230VAC, Red

2340220014

L-101-230A Xenon Strobe, 230VAC, Amber

2340220016

L-101-230G Xenon Strobe, 230VAC, Green

2340220017

L-101-230B Xenon Strobe, 230VAC, Blue

2340220018

L-101-230C Xenon Strobe, 230VAC, Clear

Size (WxHxD): 86 x 86 x 83 mm Weight: 0.2 kg

Additional Information: IP-66

3006102013

### BEXS-110AC Alarm Horn 230VAC EXD 110dB BEXS110D230

- ATEX approved Sounder Horn
- EExd IIC T4 32T
- 110 dB
- 32 alarm tones
- Zone 1 & 2



3006102014

BEXS-110DC Alarm Horn 24V DC EXD 110DB BEXS110D024

Size (ØxD): 181x 262,6 mm

Weight: AC 3.2 kg DC 3,0kg

Additional Information: IP-67

3006102011

### BEX-240 Beacon Ex BExBG05D 24VDC ATEX IP67 - Orange

- ATEX approved xenon warning light
- EX II 2 G EEx d IIC T5
- Orange
- Zone 1 & 2



3006102010

BEX-24B Beacon Ex BExBG05D 24V DC ATEX IP67 1x Cable Gland - Blue

3006102012

BEX-24R EX Approved light 24V DC , incl. 1 X Cable Gland, Ex II 2 G - EEx d IIC T5 - Red

2340200006

BEX-24Y Beacon Ex BExBG05D 24V DC ATEX IP67 1x Cable Gland - Yellow

2340200007

BEX-24G Beacon Ex BExBG05D 24V DC ATEX IP67 1x Cable Gland - Green

2340200008

BEX-24C Beacon Ex BExBG05D 24V DC ATEX IP67 1x Cable Gland - Clear

Size (WxHxD): 153 x 154 x 246 mm Weight: 2.45 kg

Additional Information: IP-67

3006102070

### SON-160 Combined Audio-Visual 24VDC WT 100 dB - Orange

- Well suited for fire and security purposes incorporating high sound output
- Low current consumption, high quality and simple installation



3006102067

SON-16B Combined Audio-Visual - Blue

3006102068

SON-16G Combined Audio-Visual - Green

3006102069

SON-16K Combined Audio-Visual - Clear

3006102071

SON-16R Combined Audio-Visual - Red

Size (WxHxD): 98 x 176 x 83mm Weight: 0.5 kg

Additional Information: IP-56

3006102015

### BEX-2300 Beacon Ex BExBG05D 230VAC ATEX IP67 - Orange

- ATEX approved xenon warning light
- EX II 2 G EEx d IIC T5
- Orange
- Zone 1 & 2



3006102016

BEX-220B Beacon Ex BExBG05D 230V AC ATEX IP67 1x Cable Gland - Blue

3006102085

BEX-230G Beacon Ex BExBG05D 230V AC ATEX IP67 1x Cable Gland - Green

3006102086

BEX-230R Beacon Ex BExBG05D 230V AC ATEX IP67 1x Cable Gland - Red

3006090474

BEX-230Y Beacon Ex BExBG05D 230V AC ATEX IP67 1x Cable Gland - Yellow

Size (WxHxD): 153 x 154 x 246 mm Weight: 2.75 kg

Additional Information: IP-67

3006102006

### AL-1000 Combined Audio-Visual 230VAC IP-56 100dB - Orange

- Combined sounder and flash alarm in a small unit
- 32 alarm tones
- 3 stage alarm





3006102059

### PD2100AC Signal Light

- With Bulb E14/15W 60MM, 240V and Lifeboat Symbol
- ABS Plastic
- Cable inlet
- 240VAC
- Supplied complete with filament lamp



Size (WxHxD): 166 x 128 x 111 mm Weight: 0.275 kg

Additional Information: IP-55

3006102005

### AL 105N-WR-O ALARM LAMP/HORN 24V DC ORANGE - 106dB

- Well suited for fire and security purposes incorporating high sound output
- Low current consumption, high quality and simple installation



Size (WxHxD): 130 x 210 x 133mm Weight: 0.8 kg

Additional Information: IP-66

3006102002

### A-100 Electronic Alarm 24VDC

- Audible signal device for all systems.
- Several different tones.
- To be wall-mounted in noisy areas like engine room, etc.
- Watertight - 106dB



Size (WxHxD): 114 x 87 x 87 mm Weight: 0.26 kg

Additional Information: IP-56

3006102003

### A-100AC Electronic Alarm 220VAC

- Audible signal device for all systems.
- Several different tones.
- To be wall-mounted in noisy areas like engine room, etc.
- Watertight - 106dB



3006102029

### DHW2-24 Ex Signal Bell 24VDC

- Ex proof loud signal bell with typical tone for warning, calling and indicating.
- Sound pressure approx. 105 dB (A)
- ATEX II 2G Ex de IIC T6



Size (ØxD): 200 x 270 mm Weight: 6.0 kg

Additional Information: For Zones 1 & 2 IP-66

2340210000

### DHH1-230 Ex Signal Horn 230VAC

- Ex proof Loud signal horn with tone for warning, calling and indicating
- Sound pressure approx. 105 dB (A)
- ATEX II 2G Ex de IIC T5, T6 Gb



Size (ØxD): 190 x 265 mm Weight: 5.5 kg

Additional Information: For Zones 1 & 2 IP-66

# UPS Power Supply



2970000011

## Online UPS with Extra Batteries 600W/30min Rack Mount

- Operating voltage 160 -280 VAC
- Output voltage 220/230/240 VAC
- Effect 600W
- Capacity minimum 30 minutes
- 2HU



**Size 2x modules (WxHxD): 440 x 89 x 332 mm**  
**Weight UPS: 13 kg Weight Battery: 16 kg**

Additional Information: 2970000021 incl.floor bracket  
115VAC: 29700000111 & 2970000121 incl.floor bracket

2970000012

## Online UPS with Extra Batteries 1000W/30min Rack Mount

- Operating voltage 160 -280 VAC
- Output voltage 220/230/240 VAC
- Effect 1000W
- Capacity minimum 30 minutes
- 2HU



**Size 2x modules (WxHxD): 440 x 89 x 430 mm**  
**Weight UPS: 22 kg Weight Battery: 29 kg**

Additional Information: 2970000022 incl.floor bracket  
115VAC: 29700000112 & 2970000122 incl.floor bracket

2970000013

## Online UPS with Extra Batteries 1500W/30min Rack Mount

- Operating voltage 160 -280 VAC
- Output voltage 220/230/240 VAC
- Effect 1500W
- Capacity minimum 30 minutes
- 2HU



**Size 2x modules (WxHxD): 440 x 89 x 608 mm**  
**Weight UPS: 31 kg Weight Battery: 43 kg**

Additional Information: 2970000023 incl.floor bracket  
115VAC 29700000113 & 2970000123 incl.floor bracket

2970000014

## Online UPS with Extra Batteries 3500W/30min Rack Mount

- Operating voltage 160 -280 VAC
- Output voltage 220/230/240 VAC
- Effect 3500W
- Capacity minimum 30 minutes
- 4HU



**Size UPS module (WxHxD): 440 x 177,4 x 670 mm**  
**Weight : 55 kg**

**Size Extra Battery mod. (WxHxD): 440 x 89 x 608 mm**  
**Weight : 40 kg**

Additional Information: 2970000024 incl.floor bracket







---

DOC NO.

**A100K11927**

February 2020

[www.zenitel.com](http://www.zenitel.com)

[sales@zenitel.com](mailto:sales@zenitel.com)

Zenitel and its subsidiaries assume no responsibility for any errors that may appear in this publication, or for damages arising from the information therein. Vingtor-Stentofon and Phontech products are developed and marketed by Zenitel. The company's Quality Assurance System is certified to meet the requirements in NS-EN ISO 9001. Zenitel reserves the right to modify designs and alter specifications without notice. ZENITEL PROPRIETARY. This document and its supplementing elements, contain Zenitel or third party information which is proprietary and confidential. Any disclosure, copying, distribution or use is prohibited, if not otherwise explicitly agreed in writing with Zenitel. Any authorized reproduction, in part or in whole, must include this legend: Zenitel – All rights reserved.