

Triumph 7260 28" Automatic Programmable Hydraulic Paper Cutter with VRCut Software

Instruction Manual



Provided by

MyBinding.com

When Image Matters.

Call Us at 1-800-944-4573

IDEAL 7260



MyBinding.com
5500 NE Moore Court
Hillsboro, OR 97124
Toll Free: 1-800-944-4573
Local: 503-640-5920

- Sicherheitshinweise • Safety precautions •
- Consignes de sécurité • Veiligheidsvoorschriften •
- Misure di Sicurezza • Normas de Seguridad •
- Säkerhetsföreskrifter • Turvallisuusohjeita • Sikkerhetsforskriftene •
- Środki bezpieczeństwa • Меры предосторожности •

IDEAL 7260

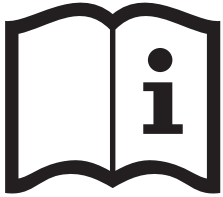

- DE** Bitte lesen Sie vor Inbetriebnahme der Maschine unbedingt diese Betriebsanleitung und beachten Sie die Sicherheitshinweise. Die Betriebsanleitung muss jederzeit verfügbar sein.
- EN** Please read these operating instructions before putting the machine into operation and observe the safety precautions. The operating instructions must always be available.
- FR** Nous vous prions de lire attentivement le mode d'emploi avant d'utiliser la machine, et attirons votre attention sur les consignes de sécurité. Les instructions d'utilisation et les consignes de sécurité doivent toujours être disponibles. Les instructions d'utilisation et les consi.
- NL** Leest u voor de ingebruik name van het apparaat a.u.b. deze gebruiksaanwijzing goed door en neemt u de veiligheidsinstructies n acht. De gebruiksaanwijzing en de veiligheids-voorschriften moeten altijd binnen handbereik zijn.
- IT** Per favore legga questo manuale di istruzione prima di mettere in funzione il distruggidocumenti e osservi le regole di sicurezza. Le istruzioni d'uso devono essere sempre disponibili.
- ES** Le recomendamos lea las instrucciones antes de poner en funcionamiento esta máquina y cumpla las normas de seguridad. Las instrucciones de servicio y seguridad deben estar siempre disponibles.
- SV** Läs igenom denna bruksanvisning innan ni startar maskinen. Var noga med säkerhetsföreskrifterna. Instruktionsmanualen måste alltid finnas tillgänglig.
- FI** Lue nämä käyttö-ohjeet läpi ennenkuin käynnistät laitteen !
Noudata turvaohjeita. Käyttöohjeiden on oltava aina saatavilla.
- NO** Lees gjennom denne bruksanvisningen før De tar i bruk maskinen
Vær oppmerksom på sikkerhetsforskriftene. Operatørmanualen må alltid være tilgjengelig.
- PL** Proszę uważnie przeczytać instrukcję obsługi przed uruchomieniem urządzenia i stosować się do przepisów bezpieczeństwa. Instrukcje obsługi muszą być zawsze dostępne.
- RU** Пожалуйста, прочитайте инструкцию по эксплуатации перед установкой аппарата, соблюдайте технику безопасности. Инструкция по эксплуатации должна находиться в доступном для пользователя месте.
- HU** A gép üzembe helyezése előtt figyelmesen olvassa el a kezelési utasítást és tartsa be a biztonsági előírásokat. Kezelési utasításnak mindig elérhetőnek kell lennie.
- TR** Lütfen makineyi çalıştırmadan önce bu kullanma talimatlarını dikkatli bir şekilde okuyunuz ve belirtilen güvenli önlemlerine uyunuz. Kullanma Talimatları her zaman kullanıma hazır olmalıdır.
- DA** Før installation af maskinen bedes De venligst læse brugervejledningen og være opmærksom på sikkerhedsanvisningerne. Brugervejledningen skal altid være tilgængelig.
- CS** Prosím přečtěte si instrukce k obsluze a dodržujte bezpečnostní upozornění. Návod k obsluze musí být vždy dostupný.
- PT** Por favor leiam o manual de instruções antes de colocar a máquina em operação e vejã as precauções de segurança. As instruções de operação deverão estar sempre disponíveis.
- EL** ΠΑΡΑΚΑΛΩ ΔΙΑΒΑΣΤΕ ΤΙΣ ΟΔΗΓΙΕΣ ΧΡΗΣΕΩΣ ΚΑΙ ΤΙΣ ΠΡΟΦΥΛΑΞΕΙΣ ΑΣΦΑΛΕΙΑΣ ΠΡΙΝ ΒΑΛΕΤΕ ΤΟ ΜΗΧΑΝΗΜΑ ΣΕ ΛΕΙΤΟΥΡΓΙΑ. ΟΙ ΟΔΗΓΙΕΣ ΧΡΗΣΗΣ ΠΡΕΠΕΙ ΝΑ ΕΙΝΑΙ ΠΑΝΤΑ ΔΙΑΘΕΣΙΜΕΣ.
- SL** Prosim preberite navodila za uporabo ter upoštevajte varnostna opozorila preden zaženete napravo. Navodila naj bodo vedno pri roki.
- SK** Starostlivo si preštudujte tento návod na obsluhu pred uvedením stroja do prevádzky a najmä bezpečnostné predpisy. Držte tento návod na obsluhu na dostupnom mieste.
- ET** Palun lugege enne masina käivitamist käesolevat kasutusjuhendit ning järgige ohutusnõudeid. Kasutusjuhend peab alati käepärast olema.
- ZH** 使用機器前，請閱讀此操作指引，並留意安全守則
操作手册必须是经常可用的。
- AR** والامان الوقاية تعليمات ملاحظة نرجوا كما الماكينة بتشغيل البدء قبل التشغيل تعليمات قراءة نرجوا لا بد من وجود تعليمات التشغيل دائمة



- DE** In der Nähe der Schneidemaschine keine Spraydosen mit entzündbaren Stoffen benutzen!
- EN** Do not use any spray cans with flammable content near to the cutting machine!
- FR** Ne pas utiliser d'aérosols de substances inflammables à proximité du massicot !
- NL** Gebruik in de buurt van de snijmachine geen spuitbussen met ontvlambare stoffen!
- IT** Non utilizzare bombolette spray in prossimità del tagliacarte!
- ES** ¡No utilizar aerosoles con sustancias inflamables cerca de la guillotinas!
- SV** Använd inga sprayburkar med brandfarliga ämnen i närheten av skärmaskiner!
- FI** Paperileikkurit lähellä ei saa käyttää syttyviä aineita sisältäviä suihkepulloja!
- NO** Ikke bruk noen spraybokser med antennerlige stoffer i nærheten av skjæremaskiner!
- PL** W pobliżu niszczarki do gilotyne nie używać aerozoli zawierających palne substancje!
- RU** Не пользоваться вблизи режущих машин аэрозольными баллончиками с воспламеняющимися веществами!
- HU** Az szeletelők közelében nem szabad gyúlékony anyagokat tartalmazó spray dobozokat használni!
- TR** Giyotinler yakınlarında yanıcı madde içeren sprey kutuları kullanmayınız!
- DA** Nær skæremaskine eller aerosol brug med brandfarlige stoffer!
- CS** V blízkosti stohový řezací stroje nepoužívejte spreje s hořlavými látkami!
- PT** Não usar latas de aerossóis com substâncias inflamáveis na proximidade do cisalhas e guilhotinas!
- EL** Κοντά στον φέτερ δεν επιτρέπεται να υπάρχουν δοχεία σπρέι με εύφλεκτες ουσίες!
- SL** V bližini giljotine ne uporabljajte razpršilnih sprejev z vnetljivimi snovmi!
- SK** V blízkosti rezačka papiera nepoužívajte spreje s horľavými látkami!
- ET** Mitte kasutada giljotiinid lähedal süttivaid aineid sisaldavaid aerosoole!
- ZH** 不得在切片機附近使用裝有易燃物質的噴霧罐！
- AR** فل باقلا داوملا عم ذا نزل ما دختسا مدع ني عتي !
عيطقت نم برقلاب لاعتشال

MyBinding.com
5500 NE Moore Court
Hillsboro, OR 97124
Toll Free: 1-800-944-4573
Local: 503-640-5920

- Sicherheitshinweise • Safety precautions •
- Consignes de sécurité • Veiligheidsvoorschriften •
- Misure di Sicurezza • Normas de Seguridad •
- Säkerhetsföreskrifter • Turvallisuusohjeita • Sikkerhetsforskriftene •
- Środki bezpieczeństwa • Меры предосторожности •

IDEAL 7260



DE Keine entzündbaren Reinigungsmittel verwenden.

EN Do not use any flammable cleaning agents.

FR Ne pas utiliser de détergents inflammables.

NL Gebruik geen ontvlambare reinigingsmiddelen.

IT Non utilizzare detergenti infiammabili.

ES No utilizar productos limpiadores inflamables.

SV Använd inga brandfarliga rengöringsmedel.

FI Älä käytä syttyviä puhdistusaineita.

NO Ikke bruk noen antenkelige rengjøringsmidler.

PL Nie stosować palnych środków czyszczących.

RU Не использовать воспламеняющиеся средства для очистки.

HU Ne használjon gyúlékony tisztítószerket.

TR Yanıcı temizlik maddeleri kullanmayınız.

DA Brug ikke brændbare rengøringsmidler.

CS Nepoužívejte hořlavé čisticí prostředky.

PT Não utilizar produtos de limpeza inflamáveis.

EL Μη χρησιμοποιείτε εύφλεκτα καθαριστικά μέσα.

SL Ne uporabljati vnetljivih čistilnih sredstev.

SK Nepoužívajte horľavé čistiace prostriedky.

ET Mitte kasutada süttivaid puhastusvahendeid.

ZH 请勿使用易燃清洁剂。

AR لا اعتشال الةلباقل الافيظنتل داوم لامعتسا مدع يغبن ي



MyBinding.com

5500 NE Moore Court

Hillsboro, OR 97124

Toll Free: 1-800-944-4573

Local: 503-640-5920

- Sicherheitshinweise • Safety precautions •
- Consignes de sécurité • Veiligheidsvoorschriften •
- Misure di Sicurezza • Normas de Seguridad •
- Säkerhetsföreskrifter • Turvallisuusohjeita • Sikkerhetsforskriftene •
- Środki bezpieczeństwa • Меры предосторожности •

IDEAL



- DE** Keine Bedienung durch Kinder!
EN Children must not operate the machine!
FR Pas d'utilisation par un enfant!
NL Geen bediening door kinderen!
IT Non lasciare utilizzare il tagliacarte a bambini!
ES No dejar que la utilicen los niños!
SV Installera maskinen utom räckhåll för barn!
FI Asentakaa laite lasten ulottumattomiin !
NO Installer maskinen utenfor rekkevidde for barn!
PL Dzieciom nie wolno obsługiwać urządzenia !
RU Не допускайте детей к пользованию аппаратом!
HU Gyerekek a gépet nem kezelhetik
TR Makinayı Çocuklar Kullanmamalıdır.
DA Må kun betjenes af voksne
CS Stroj nesmí být obsluhován dětmi!
PT As crianças não devem trabalhar com a máquina!
EL ΑΠΑΓΟΡΕΥΕΤΑΙ Η ΧΡΗΣΗ ΑΠΟ ΠΑΙΔΙΑ.
SL Otroci ne smejo uporabljati naprave
SK So strojom nesmú pracovať deti!
ET Lapsed ei tohi masinat kasutada!
ZH 勿让儿童使用机器!
AR يجب علي الأطفال عدم تشغيل الماكينة.



- DE** Nicht unter das Messer fassen!
EN Do not reach beneath the blade!
FR Ne pas passer les mains sous la lame!
NL Niet met de handen onder het mes komen!
IT Non toccare la lama nella parte inferiore!
ES ¡No tocar debajo de la cuchilla!
SV Sträck inte in handen under kniven!
FI Älä laita kättäsi terän alle !
NO Plasser aldri hender ol. under kniven !
PL Nie wkładać rąk pod noże!
RU Избегайте попадания рук под лезвие!
HU Ne nyúljon a kés alá!
TR Elinizi bıçağın altına sokmayınız!
DA Stik ikke hænderne ind under knivbladet!
CS Nesahejte pod ostří nože!
PT Não tocar na parte inferior da faca!
EL ΜΗΝ ΑΓΓΙΖΕΤΕ ΤΟ ΚΑΤΩ ΜΕΡΟΣ ΤΗΣ ΛΕΠΙΔΑΣ!
SL Ne segajte z roko pod rezilo!
SK Nevkladajte ruky pod nôž!
ET Ärge pange kätt tera alla!
ZH 请勿接触刀具的下方。
AR لا تصل تحت السكين



MyBinding.com
 5500 NE Moore Court
 Hillsboro, OR 97124
 Toll Free: 1-800-944-4573
 Local: 503-640-5920



- DE** Messer nie lose liegen lassen!
 Messer nur mit Messerwechsellvorrichtung oder im
 Messertransportkasten befördern!
 (siehe Seite 31 und 33).
 ⚠ **Warnung! Verletzungsgefahr!**
- EN** Never leave the blade unattended!
 Do not extract or transport the blade without protection!
 (See page 31 and 33).
 ⚠ **Danger! Risk of injury!**
- FR** Ne jamais laisser la lame sans protections !
 Elle ne doit être démontée qu'à l' aide du dispositif de
 changement de lame (cf. page 31 et 33) ou transportée dans
 son étui en bois !
 ⚠ **Danger! Risques de coupures !**
- NL** Laat nooit de messen alleen achter.
 Transporteer de messen niet zonder de houten bescherming
 (zie pagina 31 en 33).
 ⚠ **Waarschuwing! Opgelet voor ongevallen!**
- IT** Non lasciare mai la lama incustodita. Non rimuovere o
 trasportare la lama senza protezione. (Vedi pagina 31 e 33).
 ⚠ **Attenzione! Rischio di infortunio!**
- ES** ¡No quitar la cuchilla sin prestar atención. No desmontar no
 transportar la cuchilla sin protección! (vérase pág. 31 y 33)
 ⚠ **¡Advertencia! ¡Peligro de hacerse daño!**
- SV** Lämna aldrig maskinen obemannad. Ta inte ur eller
 transporterera kniven utan skydd. (se sid 31 och 33).
 ⚠ **Skaderisk!**
- FI** Käsittele terää aina varoen. Älä siirrä tai kuljeta
 terää ilman suojaa ! (katso sivu 31 ja 33)
 ⚠ **Loukkaantumisen vaara !**
- NO** La aldri kniven ligge ubeskyttet. Ta aldri ut kniven eller
 transporter den uten beskyttelse (Se side 31 og 33)
 ⚠ **FARE ! Muligheter for skade !**
- PL** Nidy nie pozostawiać noży bez nadzoru! Nie wyciągać lub
 transportować noży bez osłon!
 (zobacz strona 31 i 33).
 ⚠ **Ryzyko skaleczenia się!**
- RU** Не оставляйте открытое лезвие без присмотра! Не пытайтесь
 извлечь или транспортировать лезвие без специальных мер
 предосторожности! (См. страницы 31 и 33)
 ⚠ Соблюдайте выше перечисленные правила для избежания
 травм!
- HU** Soha ne hagyja a kést őrizetlenül!
 Ne vegye ki vagy ne szállítsa a kést védőtok nélkül!
 (Lásd 31. és 33. oldal)
 ⚠ **Veszély! Sérülésveszély!**
- TR** Bıycađý hiçbir zaman gözetimsiz bıyrakmayýnýz!
 Bıycađý muhafazasýz olarak yerinden çýkartmayýnýz veya
 tabýmayýnýz! (Sayfa 31 ve 33 bakýnýz)
 ⚠ **Dikkat! Yaralanma riski!**



- DA** Knivbladet må aldrig efterlades uden opsyn.
Forsøg ikke at afmontere eller transportere knivbladet uden beskyttelse! (Se side 31 og 33)
⚠ FARE! Risiko for legemlig beskadigelse.
- CS** Nikdy nenechávejte nůž bez krytu.
Nikdy nevyjímejte nebo neprepravujte nůž bez ochranného krytu (viz. strany 31 a 33)
⚠ Nebezpečí! Riskujete zranění
- PT** Deixar a faca sempre em local seguro!
Não retirar ou transportar a faca sem protecção!
(Ver pág. 31 e 33)
⚠ Perigo! Risco de dano!
- EL** ΜΗΝ ΑΦΗΝΕΤΕ ΤΗΝ ΛΕΠΙΔΑ ΑΝΕΠΙΤΗΡΗΤΗ!
ΜΗΝ ΑΛΛΑΖΕΤΕ Ή ΜΕΤΑΦΕΡΕΤΕ ΤΗΝ ΛΕΠΙΔΑ ΧΩΡΙΣ
ΠΡΟΦΥΛΑΞΗ (Δείτε σχετικά στις σελίδες 31 & 33)
⚠ ΠΡΟΣΟΧΗ ! ΚΙΝΔΥΝΟΣ ΤΡΑΥΜΑΤΙΣΜΟΥ !
- SL** Nikoli ne puščajte rezila nazaščitenega. Nikoli ne prenašajte
rezilo brez zaščite. (glej stran 31 in 33).
⚠ Pozor! Nevarnost poškodbe.
- SK** Nenechávajte nôž nechránený (nezabezpečený)!
Nevyberajte alebo netransportujte nôž bez ochrany
(vid s. 31 a 33)
⚠ ! Riziko úrazu !
- ET** Ärge jätke löiketera kunagi järelevalveta!
Ärge pikendage ega teisdalage tera kaitseseadmeteta!
(Vt lk 31 ja 33)
⚠ Oht! Vigastuste oht!
- ZH** 在没人留意的情况下，请勿离开刀具。
在没有保护的情况下，请勿取出或运送刀具！（参阅第 31 和 33 页）。
⚠ 危险！可引致受伤！
- AR** لا تترك السكين بدون إهتمام
لا تخرج أو تنقل السكين بدون حماية (أنظر صفحة 31 و 33)
⚠ خطر! التعرض للأذى

MyBinding.com
5500 NE Moore Court
Hillsboro, OR 97124
Toll Free: 1-800-944-4573
Local: 503-640-5920

- Sicherheitshinweise • Safety precautions •
- Consignes de sécurité • Veiligheidsvoorschriften •
- Misure di Sicurezza • Normas de Seguridad •
- Säkerhetsföreskrifter • Turvallisuusohjeita • Sikkerhetsforskriftene •
- Środki bezpieczeństwa • Меры предосторожности •

IDEAL 7260

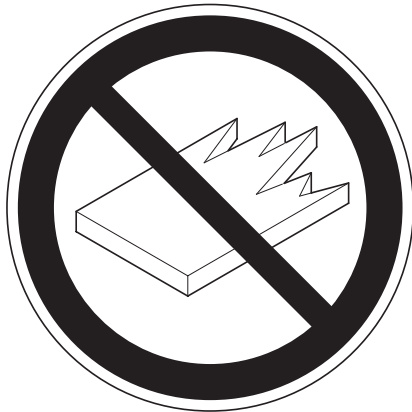

- DE** Keine harten und splitternden Materialien schneiden!
- EN** Do not cut hard materials or materials which may splinter!
- FR** La coupe de matériaux trop durs ou risquant des projections est interdite !
- NL** Snij geen harde materialen of materiaal dat kan splinteren!
- IT** Utilizzare il tagliacarte esclusivamente per il taglio di risme di carta o materiali analoghi!
- ES** ¡No cortar materiales duros o materiales que puedan astillarse!
- SV** Förstör inte hårt material eller material som kan splittras!
- FI** Asentakaa laite lasten ulottumattomiin !
- NO** Ikke kutt hardt metall eller materiale som kan splintre !
- PL** Nie ciąć twardych materiałów lub materiałów, które mogą ulec odpryśnięciu!
- RU** Данный резак не предназначен для резки твердых материалов или материалов, которые могут расщепляться!
- HU** Ne vágjon kemény vagy olyan anyagot, amely repedhet!
- TR** Sert veya parçalanabilecek malzemeleri kesmeyiniz!
- DA** Der må ikke skæres i hårde materialer eller i materialer, der kan splintre!
- CS** Neřežte tvrdý materiál, při kterém mohou ustřelovat ostré úlomky!
- PT** Não cortar materiais duros ou materiais que possam lascarse!
- EL** ΜΗΝ ΚΟΒΕΤΕ ΣΚΛΗΡΑ ΎΛΙΚΑ Ή ΎΛΙΚΑ ΠΟΥ ΘΡΥΜΜΑΤΙΖΟΝΤΑΙ!
- SL** Nikoli ne režite trdih materialov ali materialov, ki se lahko razcepijo.
- SK** Nerežte tvrdé materiály, alebo materiály, z ktorých môžu vystrelovať ostré úlomky.
- ET** Ärge lõigake kõvasid materjale ega materjale, mis võivad pilbasteks puruneda!
- ZH** 请勿切割坚硬或可裂成碎片物料。
- AR** لا تقطع الأشياء الصلبة أو الأشياء التي يتطاير منها شظايا!

MyBinding.com
 5500 NE Moore Court
 Hillsboro, OR 97124
 Toll Free: 1-800-944-4573
 Local: 503-640-5920

• Safety precautions •

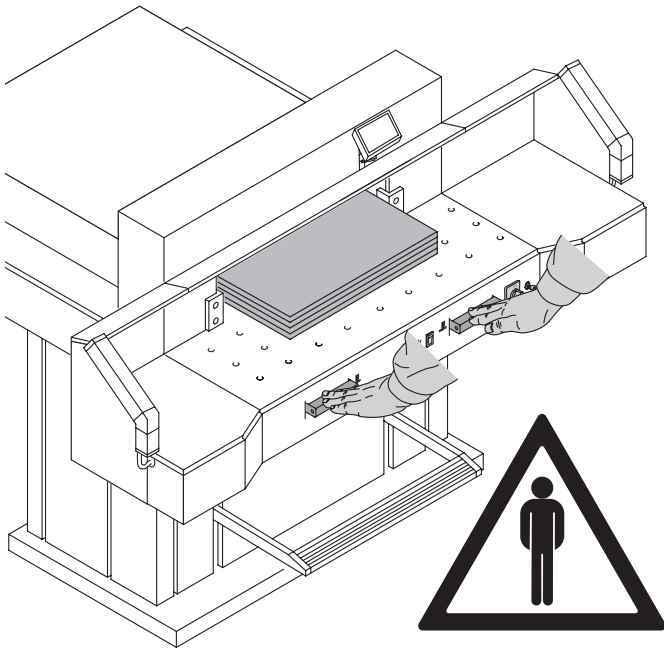

The machine is designed for cutting stacks of paper to a specified size.

This machine is constructed for "one-man operation" only!

⚠ Warning! Clips or similar damage the cutting blade.

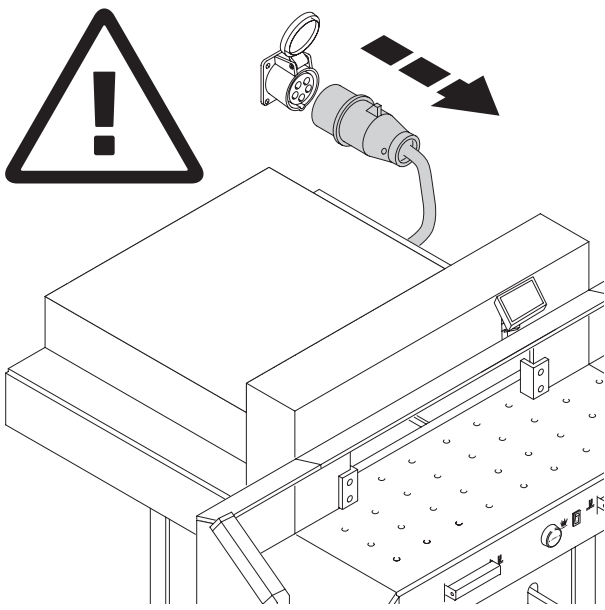

Disconnect from the mains before starting any service work or before removing the panels!

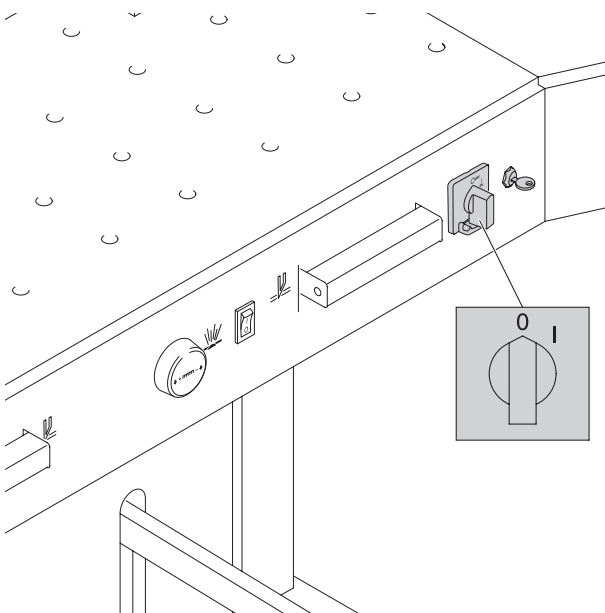

Replacement of blade and cutting stick may be performed only when the main switch is switched off!

MyBinding.com
5500 NE Moore Court
Hillsboro, OR 97124
Toll Free: 1-800-944-4573
Local: 503-640-5920

IDEAL 7260

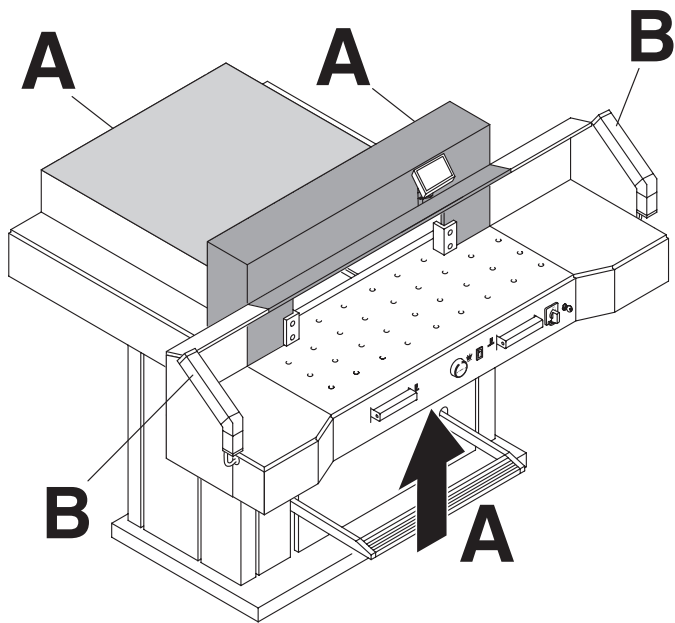

All components which may endanger the operator are covered by a guard (A).

Do not operate the machine without the following safety devices:

- Panels, tightly screwed (A).
- Safety beam guard (B).

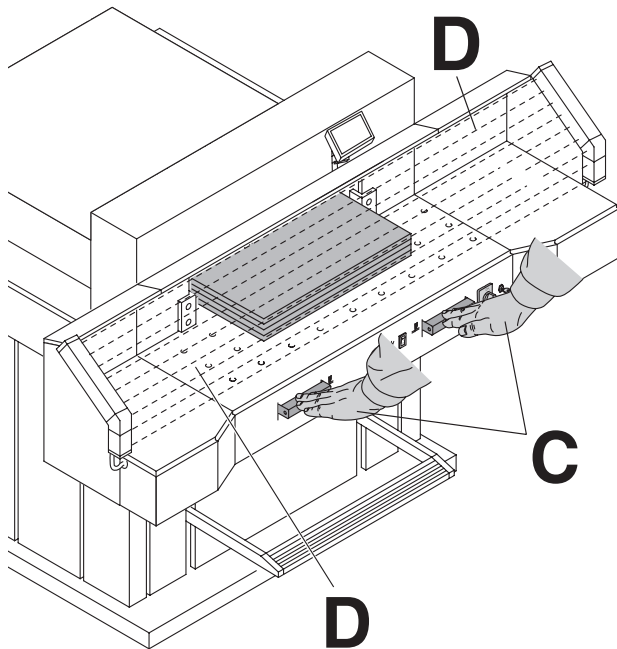

The cutting action, which is dangerous to the operator, is protected by a two-handed control system (C) and safety beam guard (D).

MyBinding.com
5500 NE Moore Court
Hillsboro, OR 97124
Toll Free: 1-800-944-4573
Local: 503-640-5920

• Safety precautions •

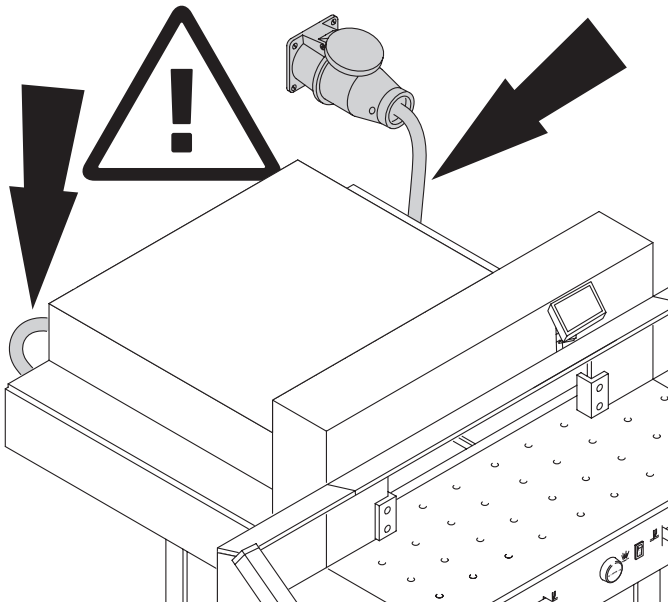

Protect mains cable against heat, oil and sharp edges!

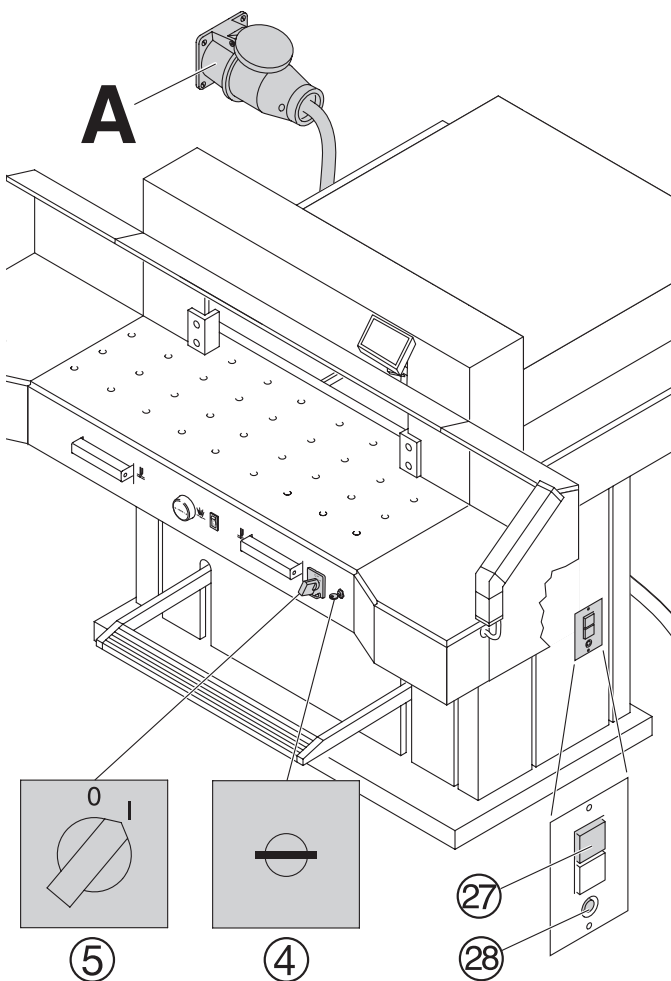

Standard machines are factory-set as follows:

- Voltage 400 V (220 V) 3 phase
- Frequency 50 Hz (60 Hz).

Machine does not function

- Is the machine ⑤ switched on?
- Is the key-switch ④ on.
- Is the green overload switch ②⑦ pressed?
- Is the black overload switch ②⑧ pressed?
- Check on-site fuse.

If the machine still does not function then the rotation must be reversed.

The machine is wired according to the IEC standards. We recommend that alterations to the rotary direction be made in the socket. It is also possible to make alterations in the plug by exchanging "L1" and "L2".

⚠ Danger!

Incorrect exchanging of the connections will endanger the operator.

This work must be carried out by an electrician.

MyBinding.com

5500 NE Moore Court

Hillsboro, OR 97124

Toll Free: 1-800-944-4573

Local: 503-640-5920

IDEAL 7260

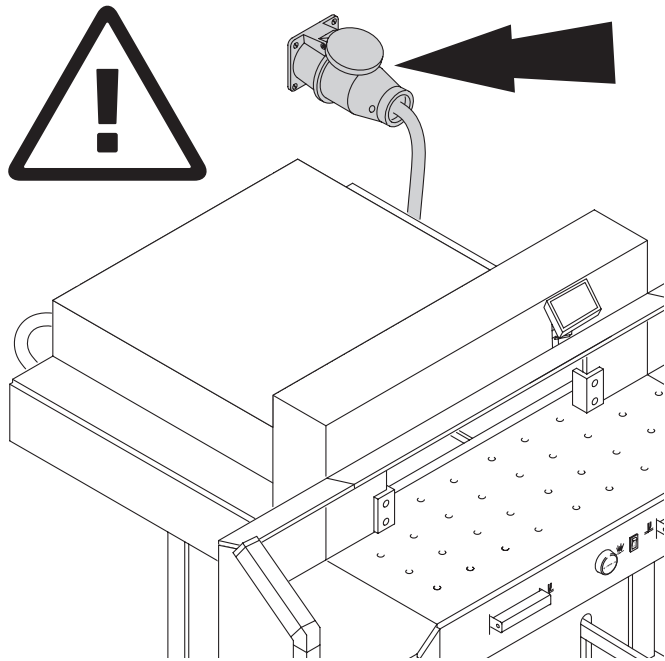

Ensure free access to mains!

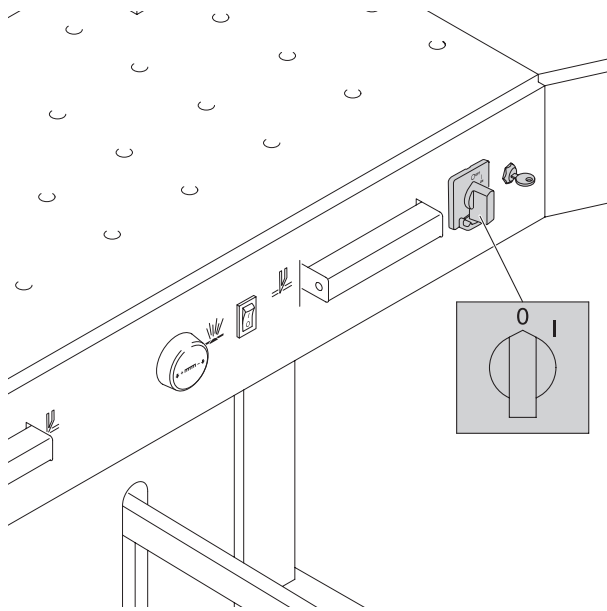

When not in use for a longer period switch off.
(Main switch to "0").

MyBinding.com
5500 NE Moore Court
Hillsboro, OR 97124
Toll Free: 1-800-944-4573
Local: 503-640-5920

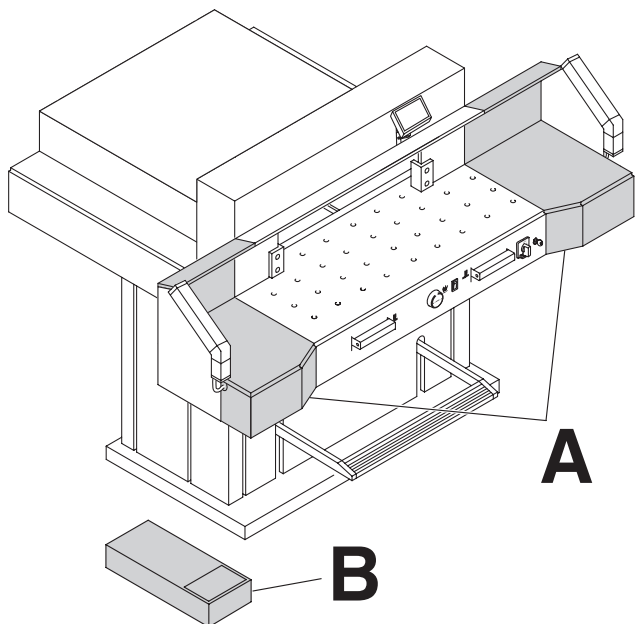

The machine is delivered ready for operation. 6 strong people are required to lift the machine from the pallet. Side tables, left and right, (A) are available as accessories.

Attach the side tables to the front table so that the upper surface is level. (Screws and nuts are in a plastic bag in the tool set (B)).

Reassemble the safety light beam.

For transport through narrow doors:

- Remove side tables

! Danger!

The machine must not be put into operation without the safety light beam.

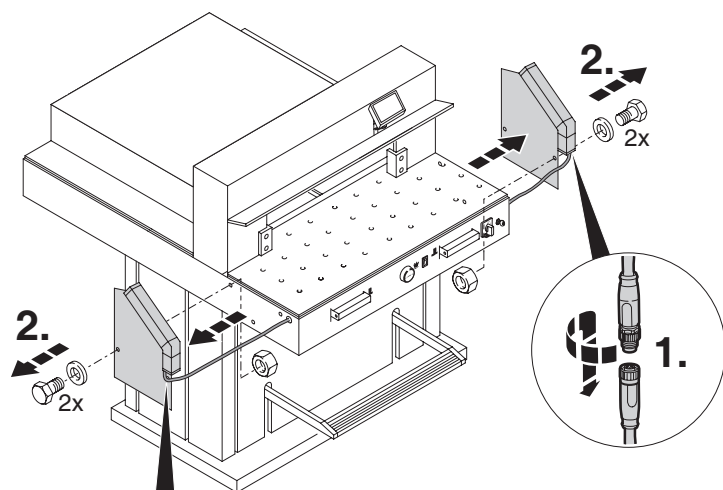

Assemble the side tables.

Remove the light beam.

(1. - 2.)

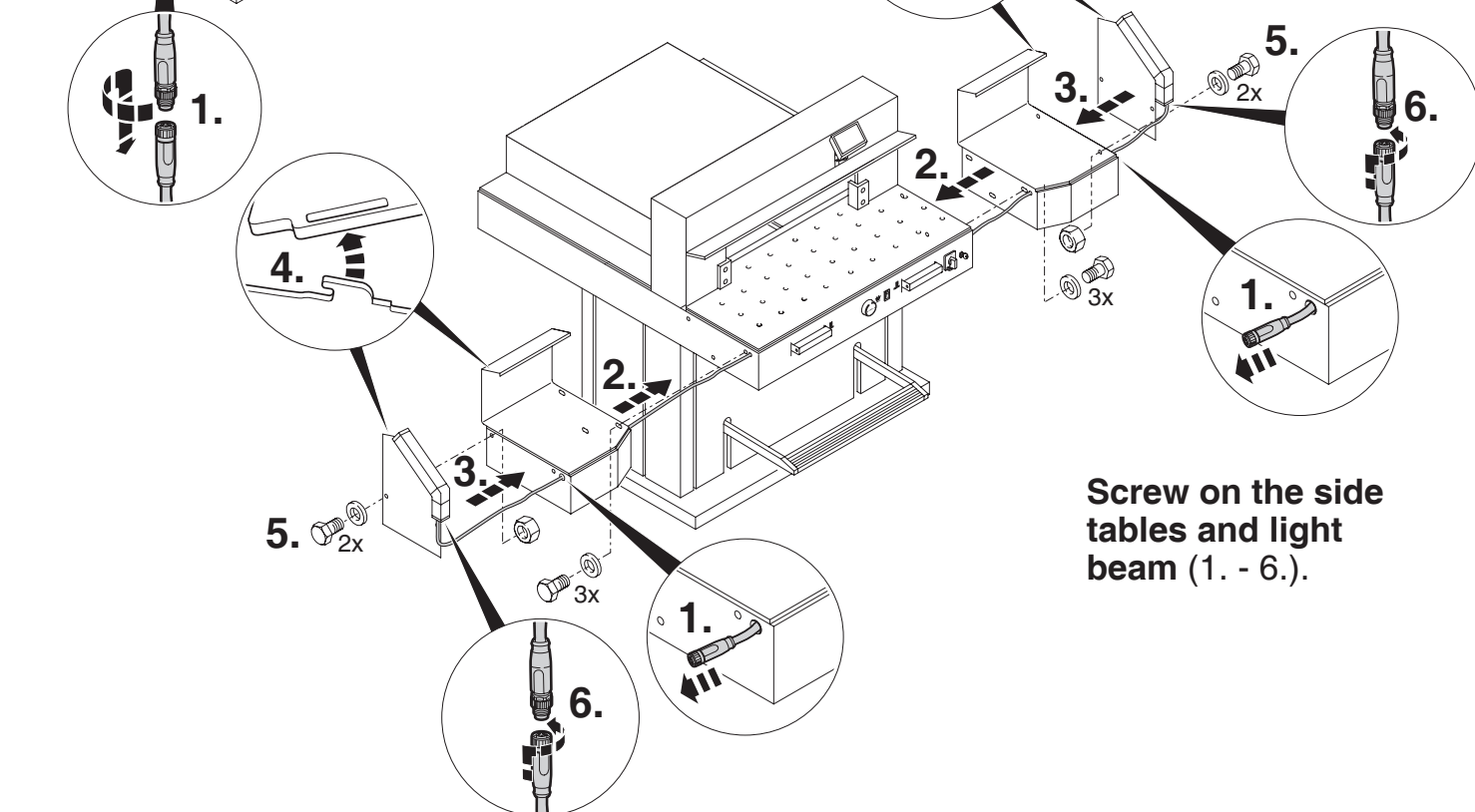

Screw on the side tables and light beam (1. - 6.).

IDEAL 7260

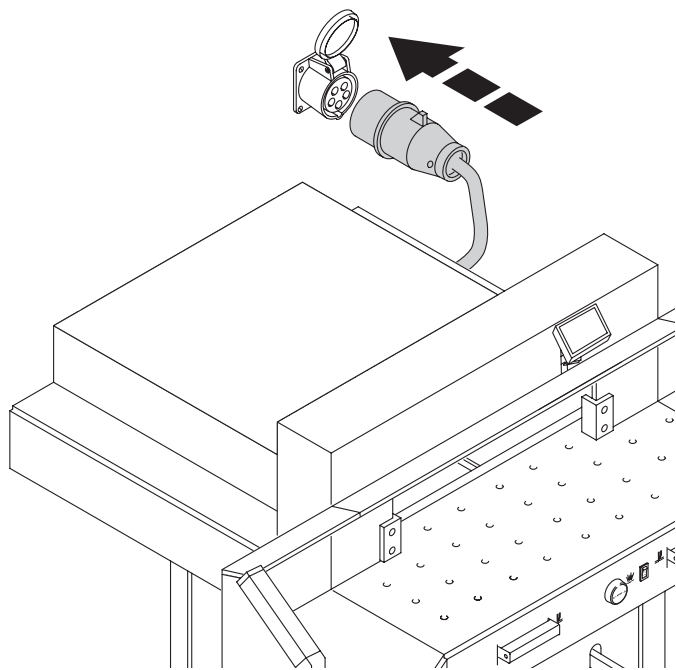

Plug into socket.

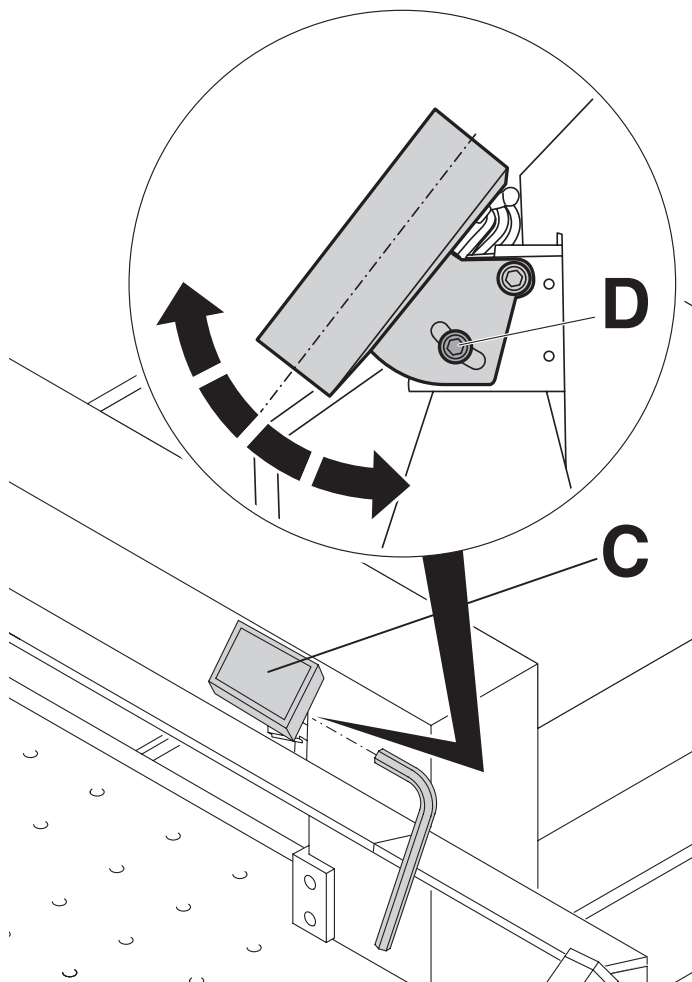

Display (C) is pivotable. By loosening the allen head screw (D), (allen wrench is in the tool box) the display can be pivoted within the elongated hole. Tighten allen screw again.

MyBinding.com
5500 NE Moore Court
Hillsboro, OR 97124
Toll Free: 1-800-944-4573
Local: 503-640-5920

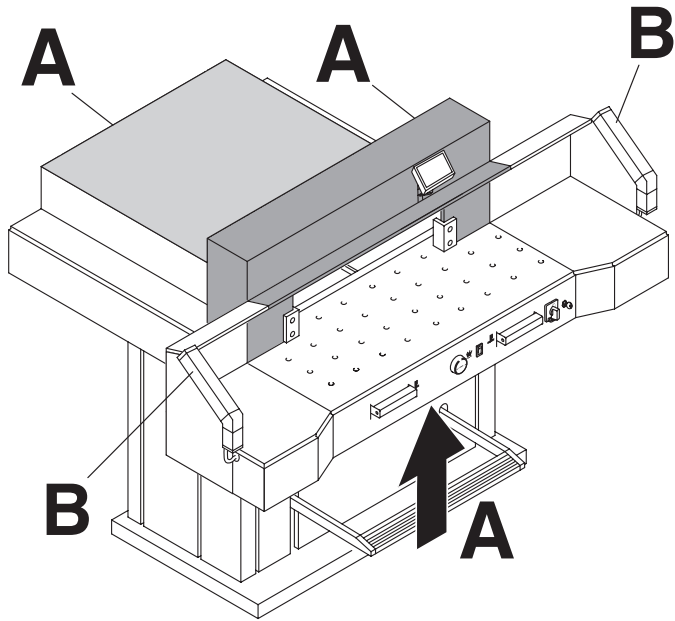

The machine may only be operated, if the operating instructions and the safety instructions have been understood. Before each use, check the safety equipment for completeness and functionality.

- All covers have to be mounted (A).
- Safety beam guard must be mounted (B).
- The release for cutting is allowed only if the two-hand safety device is operated at the same time (C)
- **Safety light beam:**
If the test rod (E, tool kit) is held into the protective field (D), an activated work cycle must be stopped immediately.

We recommend you keep a record of your test results.

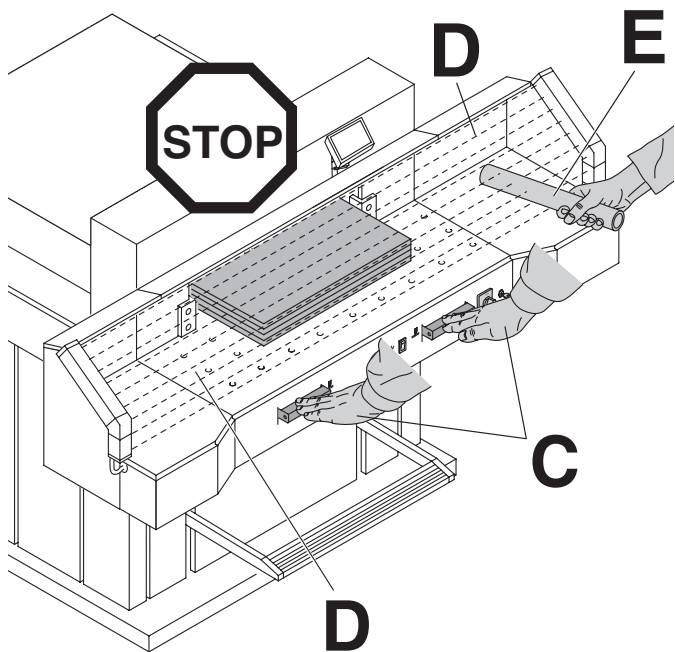

MyBinding.com
5500 NE Moore Court
Hillsboro, OR 97124
Toll Free: 1-800-944-4573
Local: 503-640-5920

IDEAL 7260

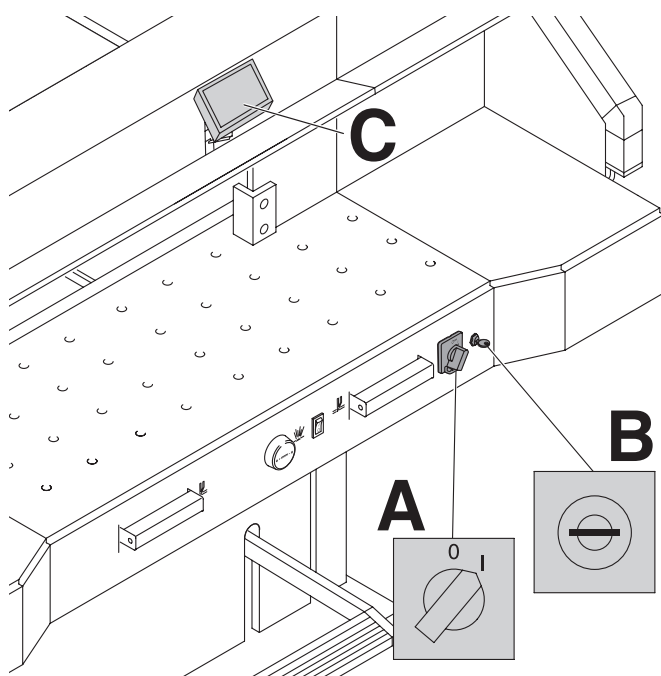

Position the main switch to "I" (A). Insert the key for the control system and turn it to the right (B).

Press Start (C) machine will automatically go to 72 cm or 28,346 inches.

The machine is now ready for use.

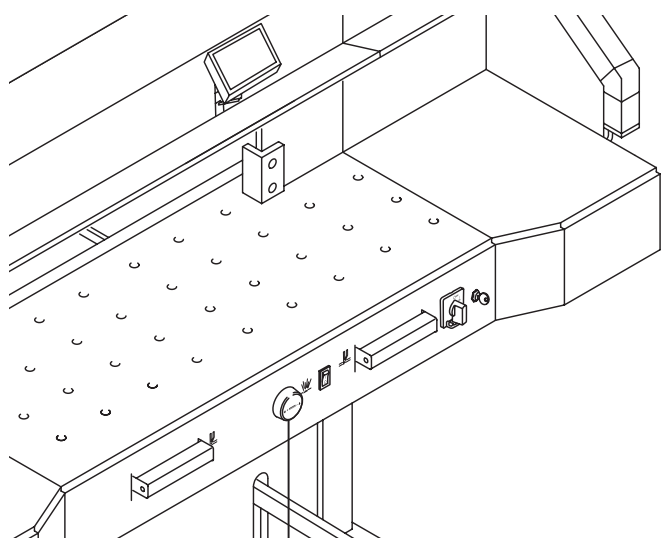

The measurement is set as follows:

- manually with the electric hand-wheel ⑰
- by programming the cutting dimensions (A). Dimension is shown on the display in inches or cm (B).

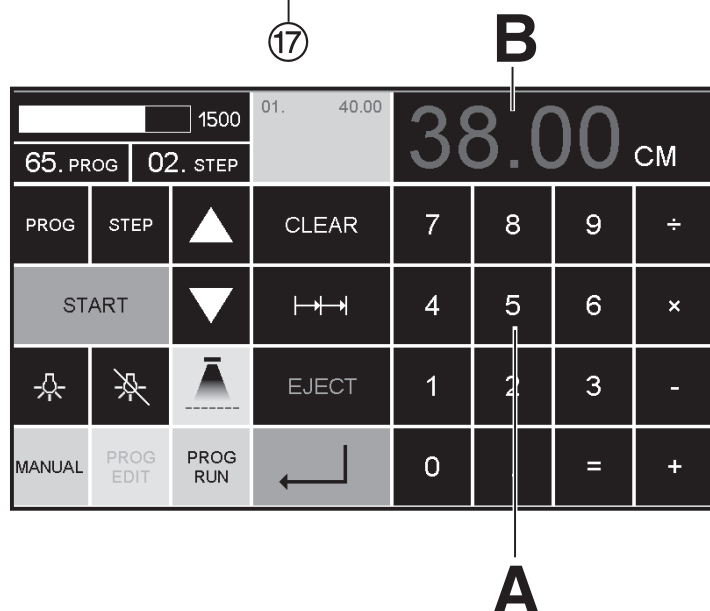

MyBinding.com
 5500 NE Moore Court
 Hillsboro, OR 97124
 Toll Free: 1-800-944-4573
 Local: 503-640-5920

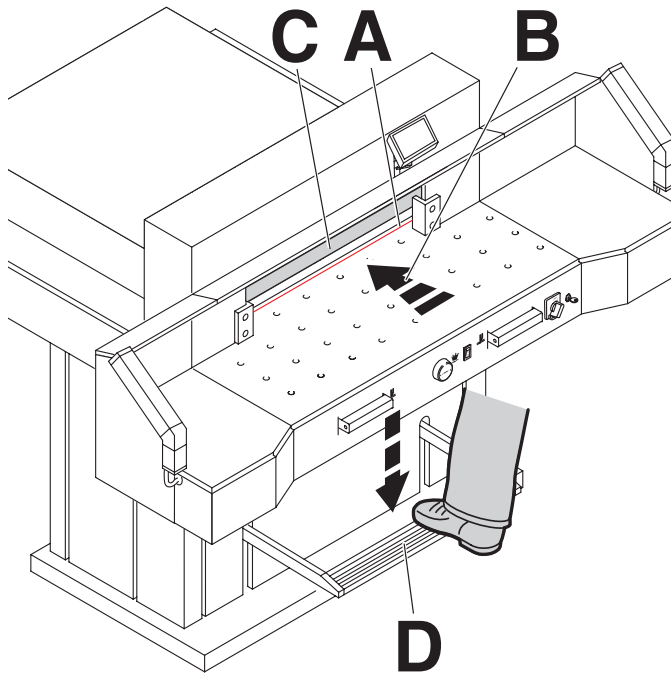

Optical cutting line indicator:

Optical cutting red line (A), indicates the position of the cut. Blade cuts on the front edge (B) of the light beam.

Mechanical cutting line indicator:

The clamp (C) can be used as cutting line indicator for cutting. Pre-clamping can be performed using the foot pedal (D).

Only use the optical cutting line indicator and mechanical cutting line indicator when no exact cut is required.

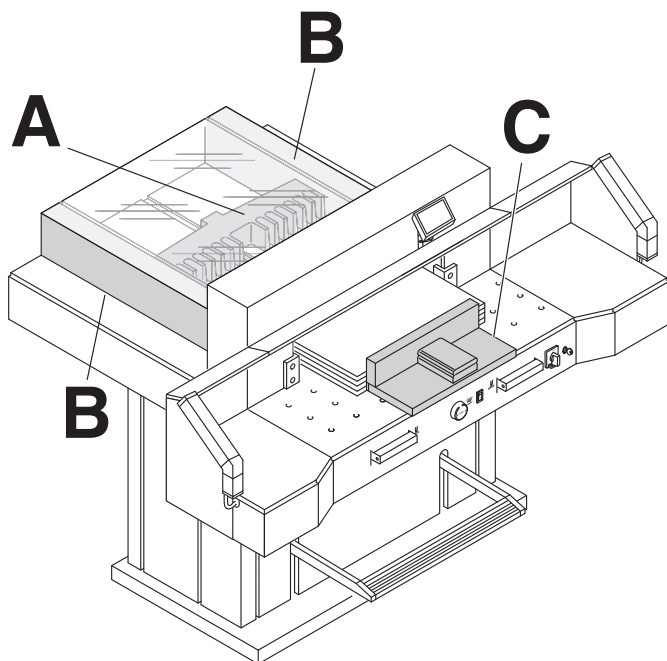

Position the paper on the backgauge (A) and side lays left or right (B).

To move paper stacks, please use the paper knock-up block (C) provided.

(Run backgauge to the front for turning the paper stack).

MyBinding.com

5500 NE Moore Court

Hillsboro, OR 97124

Toll Free: 1-800-944-4573

Local: 503-640-5920

IDEAL 7260

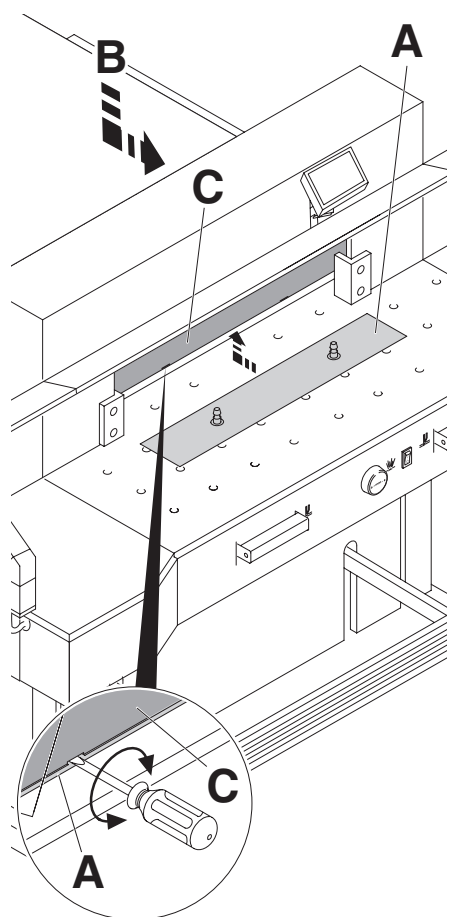

False clamp plate:

A clamp plate (A) is fitted to the machine to prevent pressure marks on sensitive material.

To dismantle:

- Remove the clamp plate (A) by turning the screwdriver (found in tool box) in the space between the clamp and clamp plate.
- Store the clamp plate in the provided holder (B).
→ The remaining cut, without false clamp, is 20 mm

⚠ Warning!

Make sure the false clamp is in the provided holder otherwise the measurement from 20 mm - 90 mm cannot be cut.

To mount:

- The clamp plate (A) is inserted to the top into the clamp (C).
→ The remaining cut, with false clamp, is 90 mm

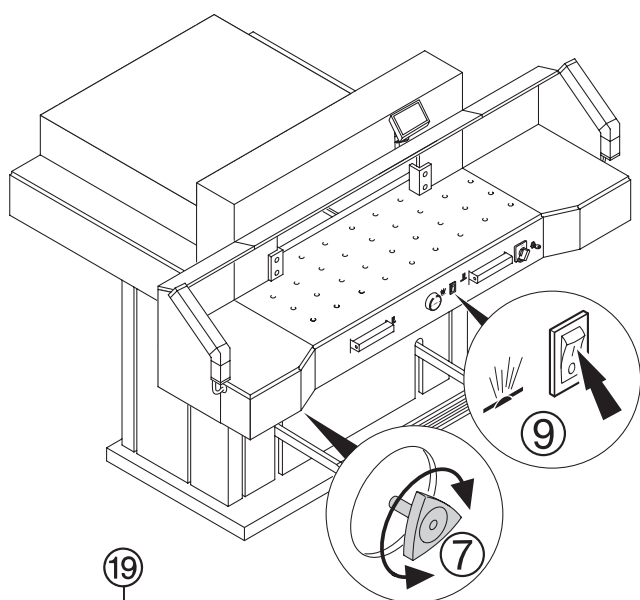

Airtable:

It is easier to position large stacks of paper when the airtable ⑨ is switched on.



Setting clamping pressure:

The clamp pressure can be adjusted using the adjustment knob ⑦. The clamping pressure can be read on the light panel ⑱.

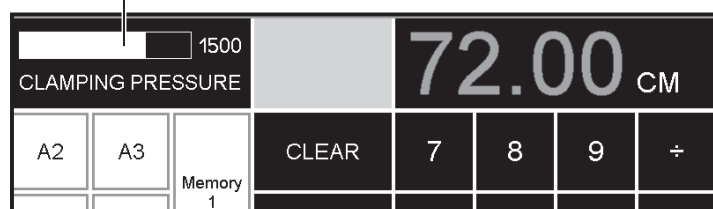

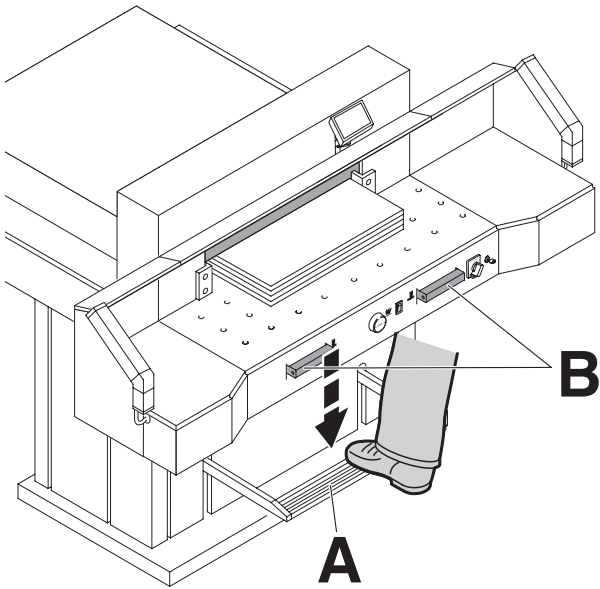

The clamp moves automatically when cutting is activated.
The paper can be pressed in advance, with the foot pedal.
Cutting is activated by pressing both actuators (B) on the front table.

Symbols for cutting activation:
Cutting sequence with automatic clamping.

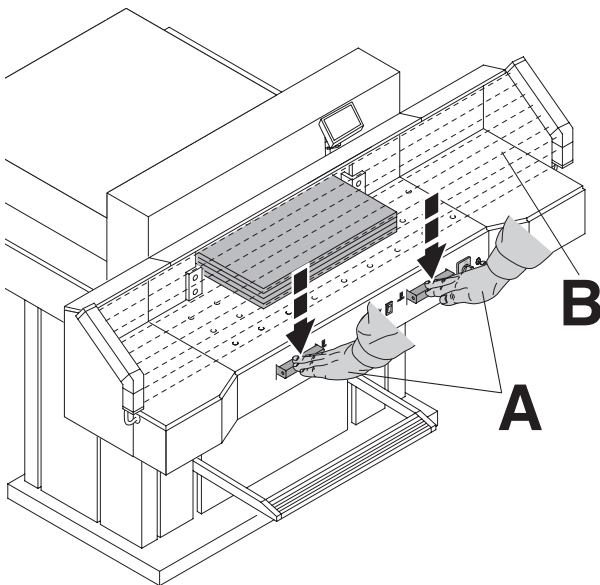

Cutting activation:
Press both actuators of the two-handed control system (A) simultaneously and keep them pressed until the paper is completely cut. The safety area (B) must be free.

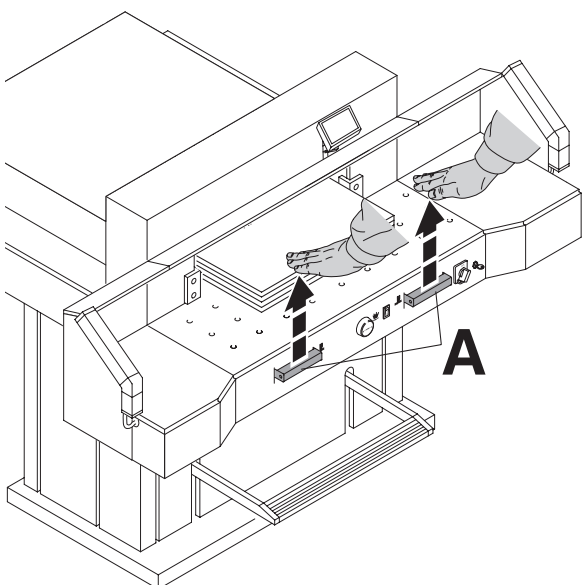

To interrupt or stop cutting:
To interrupt or stop cutting, release both actuators (A) of the two-hand control.

MyBinding.com
5500 NE Moore Court
Hillsboro, OR 97124
Toll Free: 1-800-944-4573
Local: 503-640-5920

IDEAL 7260

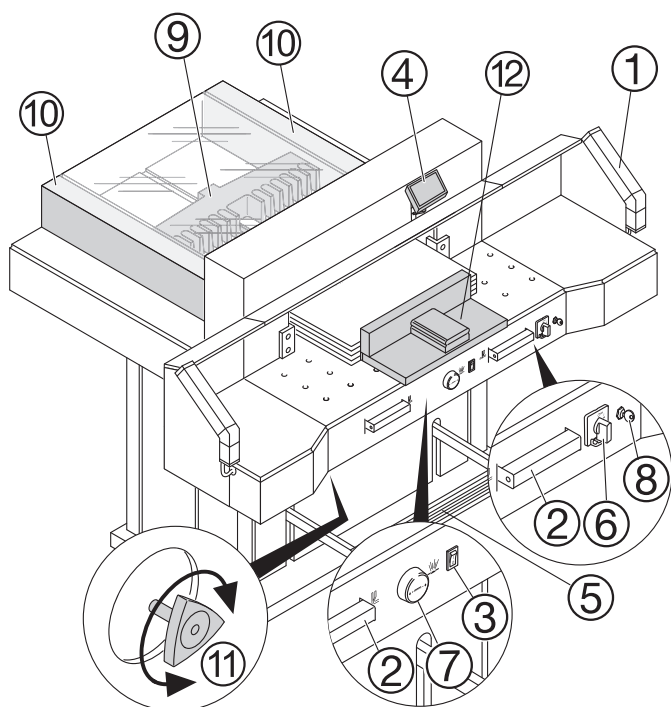

Operating elements

- ① - Safety light beam
- ② - Safety two-handed control system clamping and cutting
- ③ - Air table On-Off
- ④ - Backgauge control
- ⑤ - Foot pedal
- ⑥ - Main switch
- ⑦ - Hand-wheel for backgauge setting
- ⑧ - Key switch
- ⑨ - Backgauge
- ⑩ - Side lay left and right
- ⑪ - Clamp pressure adjustment
- ⑫ - Paper knock-up block

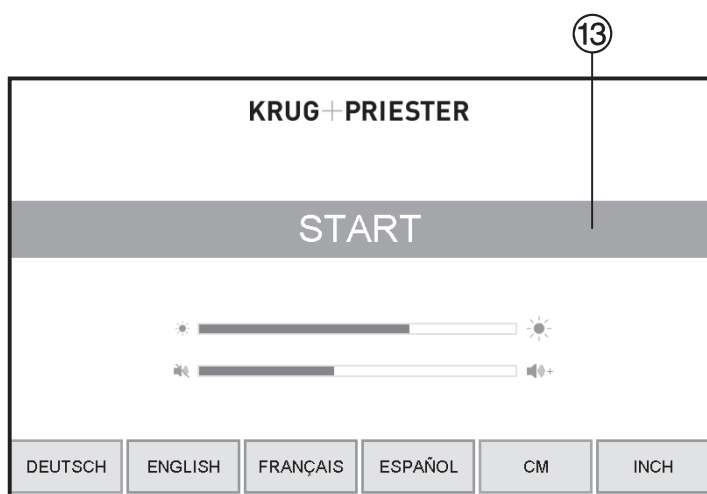

Start machine

- Main switch ⑥ to position "I".
Start screen appears
The following functions are changeable:
Brightness
CM/INCH
Touchtone volume
Language
Display / status photocell ⑳ green - red
Clamping pressure ㉑
 - Press START ⑬ → backgauge ⑨ moves to the rear and searches for the reference position, wait until a measurement is shown in the display ④
7260 = 72.00 cm, 28.346 inches
 - The DIN and free programmable measurements are recallable with the respective buttons ㉒.
- Memory 1: A2, A3, A4, A5,
Memory 2: A6, A7, B3, B4
Memory 3:
Memory 4:
and in inch
Memory 1: 4¼", 5 ½", 7", 8 ½"
Memory 2: 11", 12", 14", 17"
Memory 3:
Memory 4:

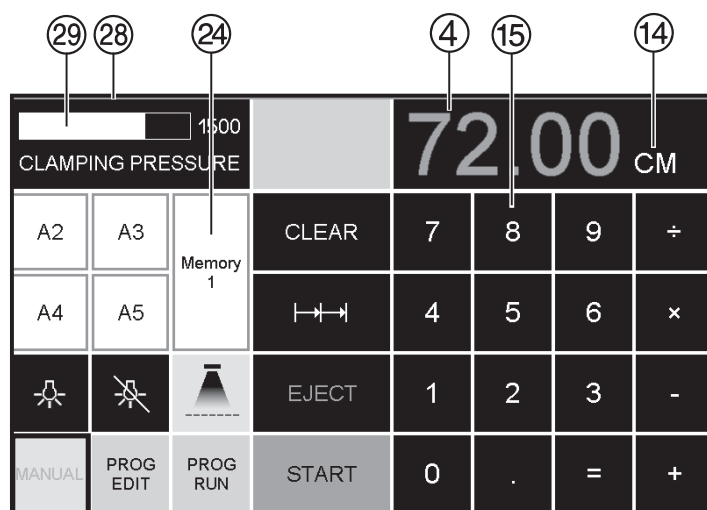

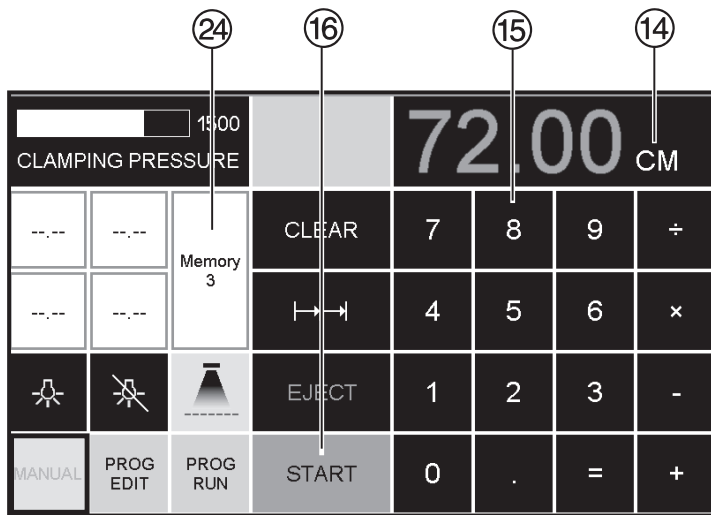

- In memory 3 + 4 (mm and inch) no measurements are saved. Until a first input of data the following will be shown in the corresponding fields: . **The measurements entered remain stored. They cannot be deleted but overwritten.**

How to program Memory 3 and 4

Press the memory button to enter the memory platform (3 or 4). Enter the required measurements or overwrite them. Press the button and keep it pressed until an acoustic signal sounds, the measurements have been saved now.

⚠ Warning!

Before storing or cutting a measurement please check if the correct measurement scale (cm or inch) see above is stored. (7260 = 72.00 cm, 28.346 inches) Is shown on the screen see .

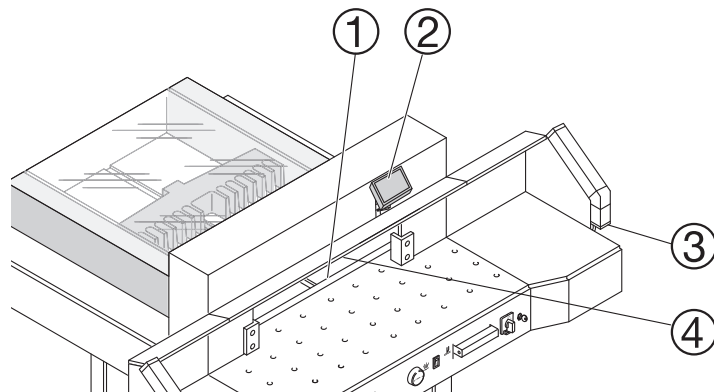

After 30 minutes the machine () switches to energy-saving mode. The machine is reactivated by touching the keypad area .

Bright LEDs illuminate the working area (). The LED button () has 3 switching steps

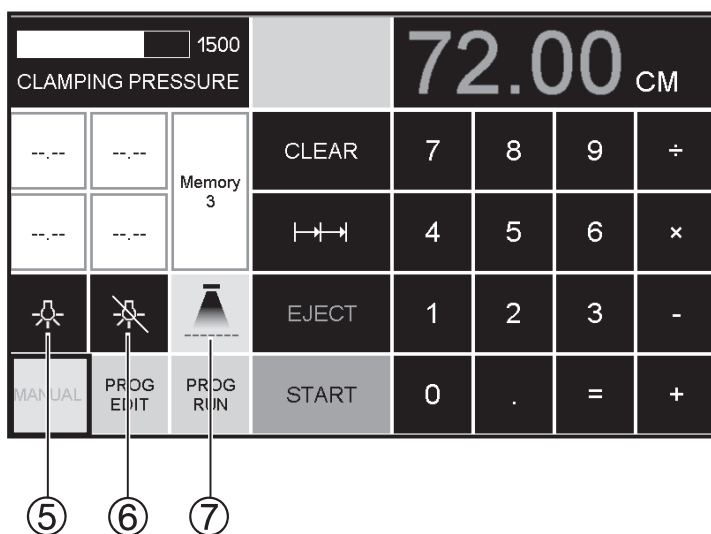

- Press 1 x → brightness 3
- Press 2 x → brightness 2
- Press 3 x → brightness 1

Light OFF → .

Optical cutting line indicator → (ON/OFF)

IDEAL 7260

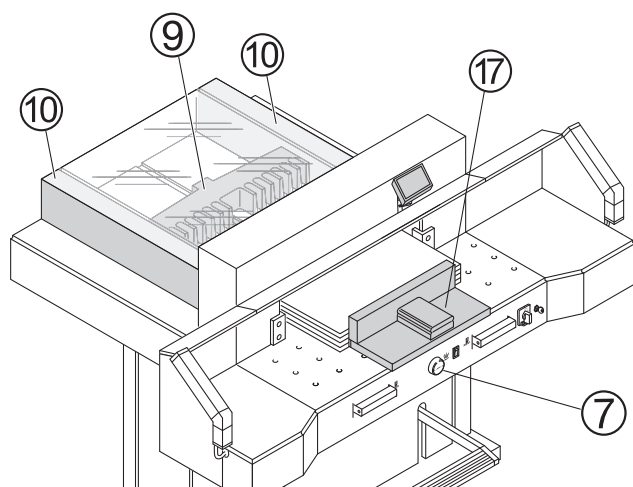

Cutting activation

⚠ Warning!

- Run backgauge to the front for turning the paper stack
- Do not interrupt the upward movement of the blade by performing switching procedures
- Wait until the display is green before activating a cut
- Blade must always be at the top and be covered by the clamp. Do not touch the blade.

⚠ Risk of injury!

Cutting to specified dimensions

- Press **MANUAL**
- Enter dimension on the numerical key pad ⑮ → Measurement is shown in red (If a wrong dimension is entered this can be corrected by pressing the **CLEAR** button)
- Press **START** ⑯ → dimension is approached, → Measurement is shown in green
- Insert paper and move by means of the stacking angle ⑰ to the backgauge ⑨ and side lay on the left ⑩
- Release the cut.

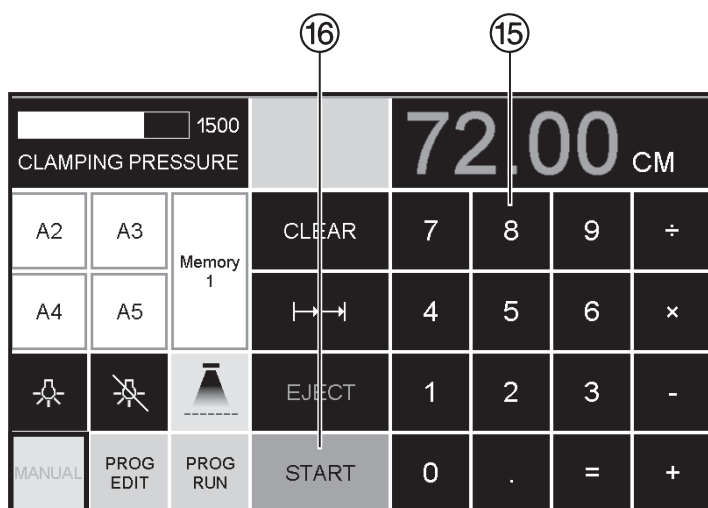

Cut according to markings

- Press **MANUAL**
- Adjust the backgauge with the hand-wheel ⑦ to the back
- Insert paper and move by means of the stacking angle ⑰ to the backgauge ⑨ and side lay on the left ⑩
- Turn the hand-wheel ⑦ to the right until the marking on the paper to be cut is below the cutting line indicator
- The further the hand-wheel ⑦ is turned to the right, the quicker the backgauge moves. If the hand-wheel is turned to the left the backgauge will return quicker.

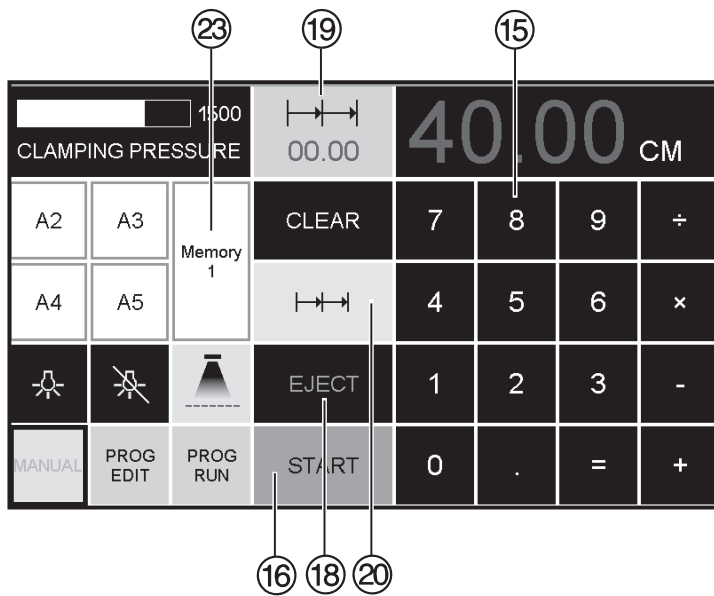

Eject function

If EJECT ¹⁸ is pressed instead of START ¹⁶, after inserting the measurement ¹⁵, the backgauge will advance forwards so that paper can be removed. Finally the backgauge moves to the last setting.

Multiple cut

- Enter the start dimension on the display ¹⁵
- Advance to the measurement with the START ¹⁶
- Push the paper to the backgauge
- Press multiple cut ²⁰
- Multiple cut sign appears top left together with the value 00.00 ¹⁹
- Enter multiple cut measurement (appears in red letters)
- Press START → the backgauge advances by the multiple cut size
- This is repeated everytime a cut is activated.

Exiting program-mode

- Press multiple cut ²⁰ (yellow). Multiple cut sign and value are deleted.

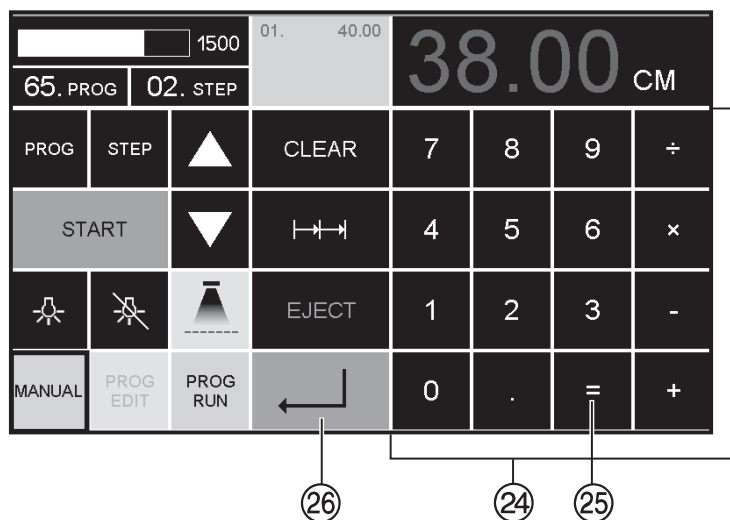

Calculator function ²⁴

- Calculate the desired measurement, e.g. $40 - 2 =$ ²⁵ → ↓ ²⁶ and the backgauge advances immediately to 38.

IDEAL 7260



Programming

This control system enables you to store 99 programs with 99 programmable steps. One step represents one measurement. After entering the program numbers you are able to change between several program steps with the button ▼ and ▲.

First figure on display ②① = program number.
Second figure on display ②② = program step.

Each program step corresponds to one dimension. The indicated program step can be overwritten at any time. These programs remain stored when the machine is off.

Entering a program

- Press **PROG EDIT** → "Load program no." appears
- Enter program number 01 ... 99, with ↵
(Top number ②① on display = program number)
- If measurement is shown on the display the program is reserved, select another program
- Program step "01 Step" 00.00 ②② appears.
(Second figure on display ②② = program step.)
- Enter dimension, or move the backgauge to the desired measurement with the hand-wheel ⑦
- Store the measurement ↵, next program step appears.
- Enter the next measurement and with Enter ↵ store the measurement etc.
- Should the entered program be required immediately → press **PROG RUN**
- Press Enter ↵
- Press START
- Escape the program mode press **MANUAL**

Cancel a program

- Press **PROG EDIT**
- Scroll with PROG until "Delete program no." appears
- Enter Program number
- Press Enter ↵
- Press Enter ↵.

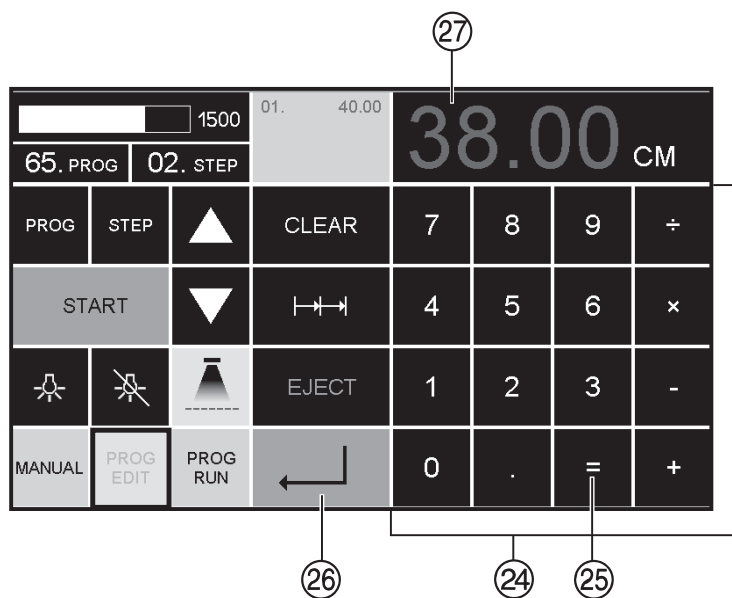

Calculator function ²⁴ in programming

- Press **PROG EDIT**
- Enter program number
- Enter the 1st program step e.g. start-up measurement 40 cm
- Store the measurement with enter ↓ ²⁶
- Calculate the desired measurement e.g. $40 - 2 =$ ²⁵ → ↓ ²⁶, the calculated measurement 38 ²⁷ flashes.
- Pressing the Enter-key ↓ ²⁶ again, the calculated measurement is saved in the corresponding step.

IDEAL 7260



Adapting a program when the printer's imprint deviates

- Press **PROG RUN** → "Load program no." appears
- Enter program number 01 ... 99, and with 2 x Enter ↵ proceed to Step 1
- Correct the cutting position of the backgauge with the hand-wheel
- **MODIFY** ²³ appears on the screen and the measurement flashes
- To store press **MODIFY**
- Release a cut and turn the paper
- If the printer's imprint deviates it can be corrected during the first two cuts via the hand-wheel – see above
- Correction is only possible during the first two cuts
- After leaving the **PROG RUN** mode the original data is stored again.

Delete a step

- Press **PROG EDIT**
- Enter program number, confirm with Enter ↵
- Select program step with the arrow keys ▲ and ▼
- Scroll with **STEP** until "Delete step no." appears, Press 2 x Enter ↵.

Insert a step

- Press **PROG EDIT**
- Select a program, confirm with Enter ↵
- Scroll with **STEP** until "Insert step no." appears
- Enter insert position e.g. 02
- Confirm with Enter ↵
- Enter a measurement
- Store the measurement with ↵
- The cutting position can be shown on the screen with the arrow keys ▲ and ▼.

Changing a program step

- Press **PROG EDIT**
- Select a program, confirm with Enter ↵
- Scroll with **STEP** until "Load step no." appears
- Enter step position e.g. 03
- Confirm with Enter ↵
- Enter a new measurement, Store the measurement with ↵.

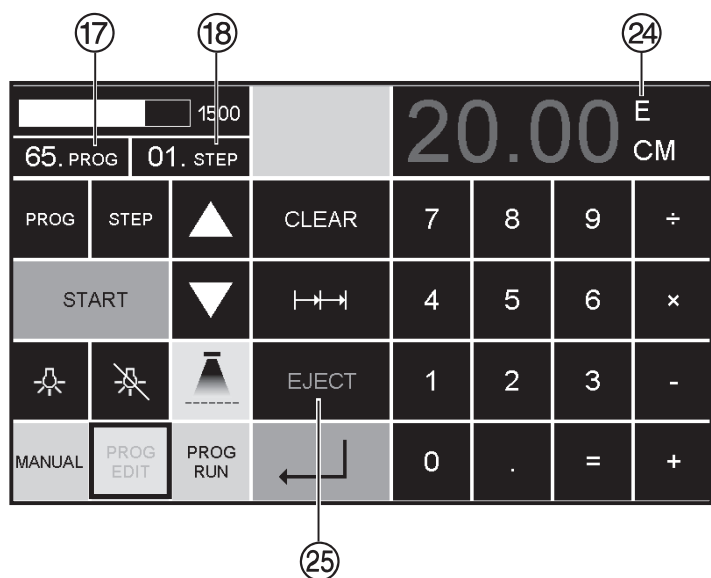

Eject function program

- If a short measurement e.g. 30 cm and then a long measurement e.g. 40 cm is cut at the start of a program then it is wise to insert an EJECT ²⁴ after the first cut so that the paper is pushed to the front.
- The EJECT function can be added each time a measurement is entered and ejects before advancing to the next measurement. When the eject function is programmed an "E" ²⁴ appears top right in the display.
- Inserting an Eject function subsequently in the program. Select a program and advance to the step to be changed with the arrow keys and Enter the new measurement and before activating the enter button press EJECT ²⁵.

Example of a program eject function

- Press **PROG EDIT**
- Enter program number e.g. 08
- Press Enter
- 1. Enter program Step e.g. 30 cm
- Press Enter
- 2. Enter program Step e.g. 40 cm
- Press EJECT and with Enter store the dimension.

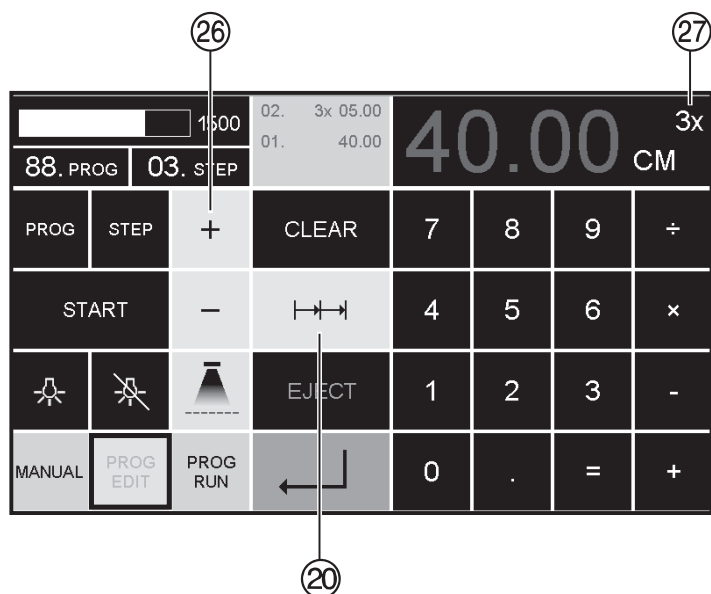

How the example works

- Press **PROG RUN**
- Enter program number 08
- Press Enter
- Press **START**, Measurement is approached
- Insert paper
- Release cut 1
- Eject (Ejection is completed, turn the paper)
- The backgauge moves to program step 2
- Release cut 2

Multiple cut program

- Press **PROG EDIT**
- Enter program number
- Enter the 1. program step e.g. start-up measurement 40 cm
- Store the measurement with Enter
- Press the multiple cut symbol ²⁰
- Enter the number of cuts ²⁶ with the + button ²⁷ (max. 15 cuts) followed by the multiple cut size (cutting width).
- Store with Enter .

IDEAL 7260

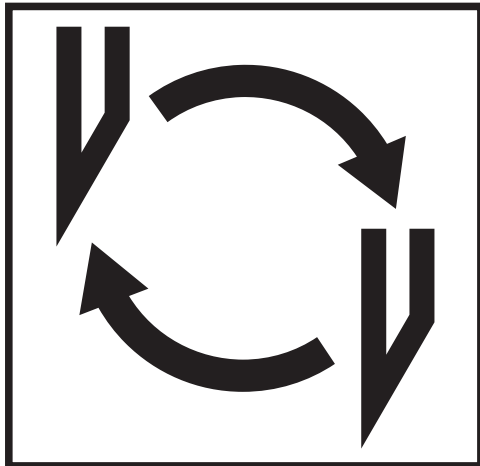

If the cutting quality decreases:

- Check the cutting depth (see page 36).
- Check the cutting stick (see page 32).
- Replace or grind the blade (see page 28 - 36).

The blade cannot be ground if the blade height is less than 8,3 cm / 3,29 inches.

A new blade must be used.

The blade may only be ground by a qualified supplier or from the manufacturer Krug & Priester, D-72336 Balingen.

⚠ Danger! Risk of injury!

The blade is extremely sharp. Do not extract or transport the blade without protection. Changing the blade may only be performed by trained staff.

• Blade and cutting stick replacement •

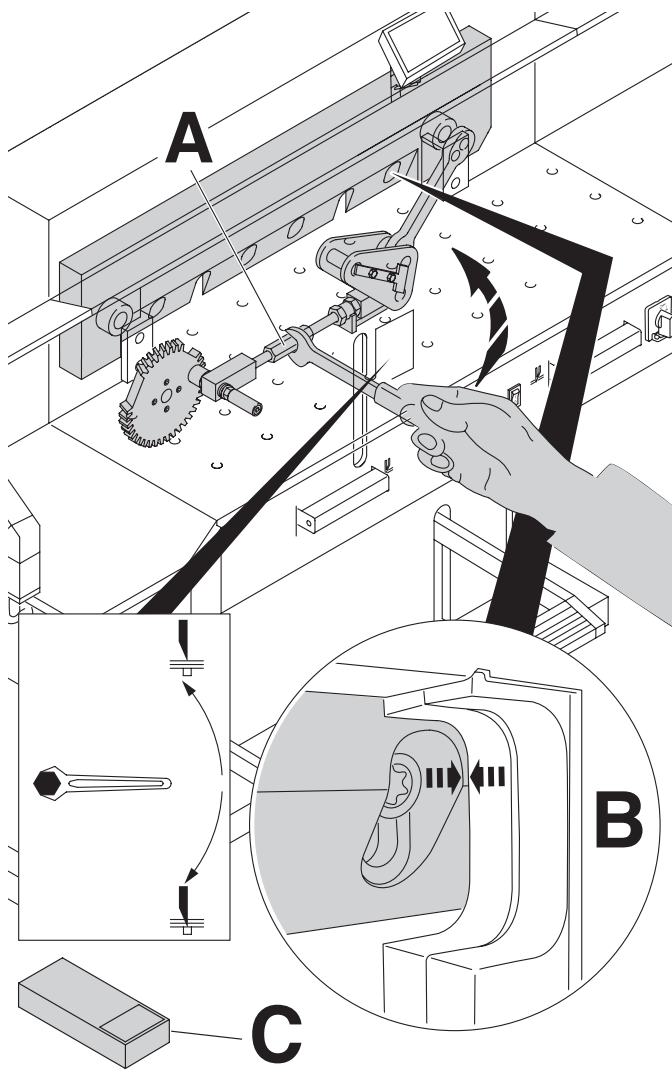

Turn the blade depth adjustment (A) towards the top until the blade screw recess corresponds with the frame recess (B). (Spanner found in tool set (C)).

Remove spanner
⚠ Danger! Risk of injury

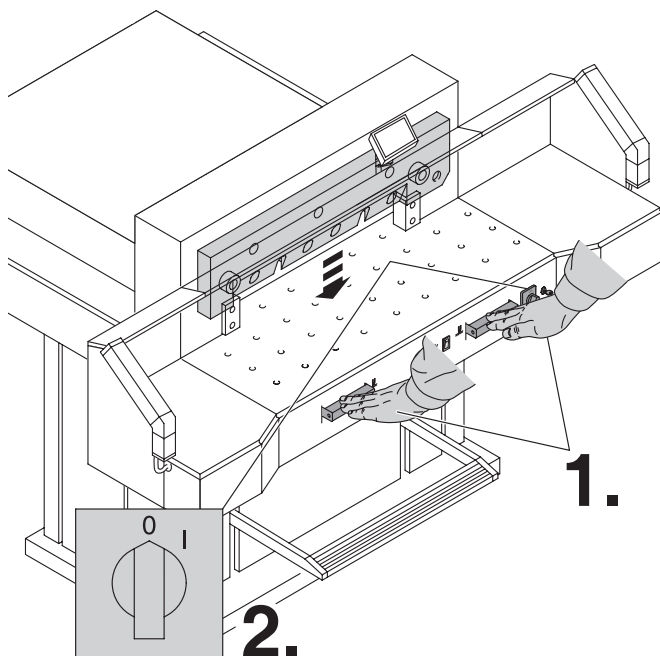

Lower the blade by pressing both cutting buttons (1.). Keep one button pressed and turn off the main switch (2.).

IDEAL 7260

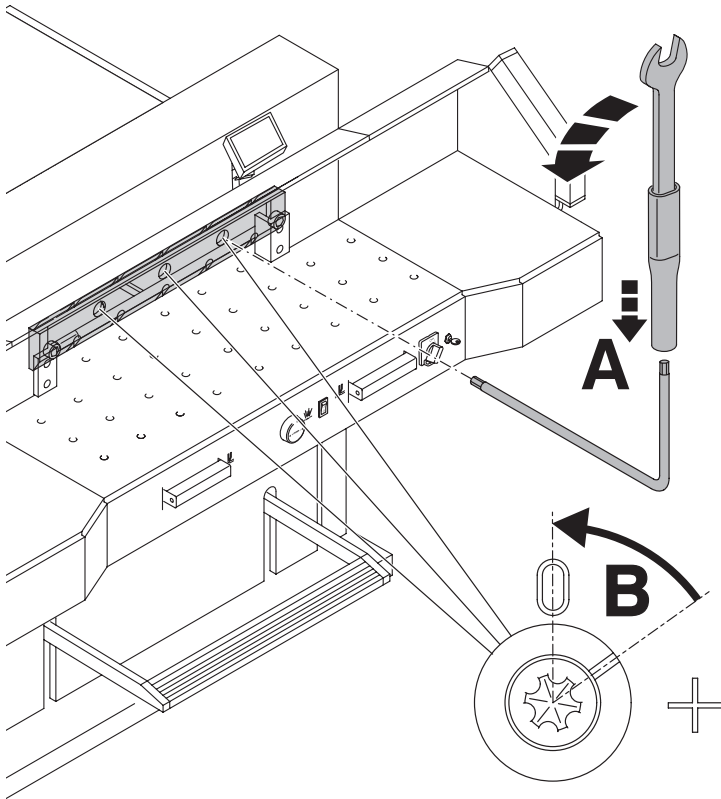

The 3 eccentrics are now exposed and should be turned counter clockwise to position "0" with the special wrench and attachable extension pipe (A) (in the tool set). The slot must correspond to position "0" (B).

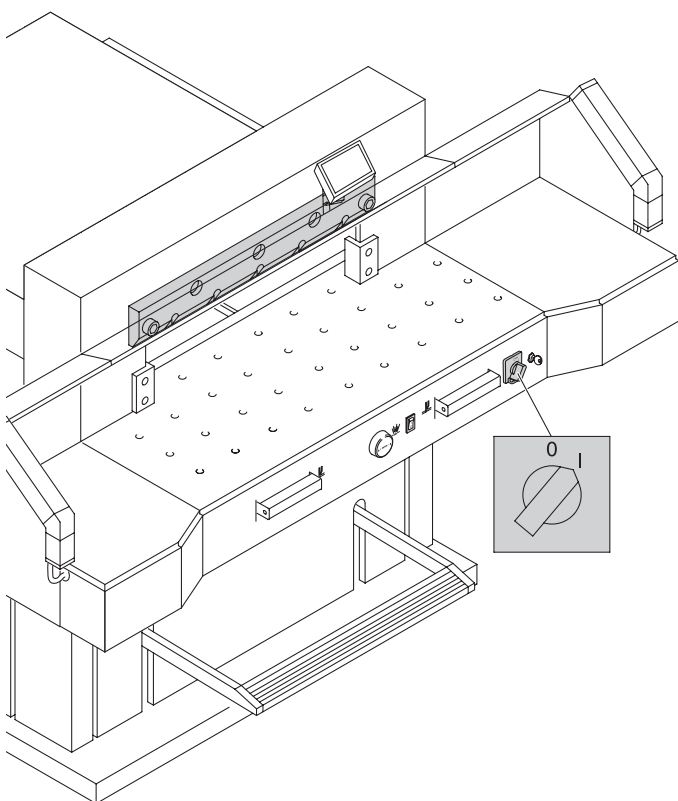

Remove the special wrench and turn on the main switch until the blade returns to the home position.

MyBinding.com
5500 NE Moore Court
Hillsboro, OR 97124
Toll Free: 1-800-944-4573
Local: 503-640-5920

• Blade and cutting stick replacement •

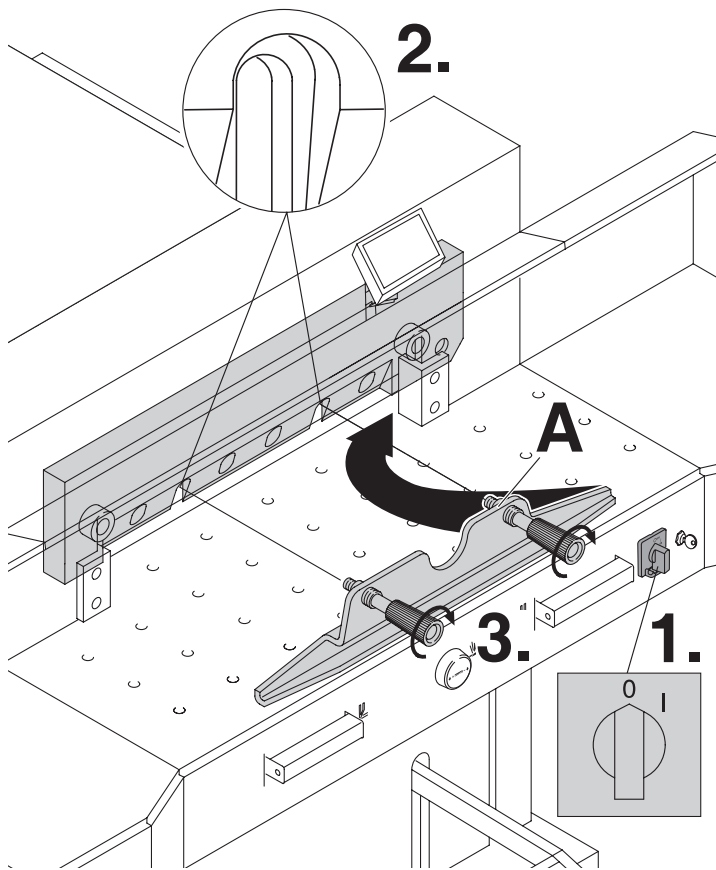

Position the main switch to "0" (1.)
Remove the 2 blade screws on the elongated holes (2.). Then put the blade changing tool (A) into place and fasten it to the blade (3.).

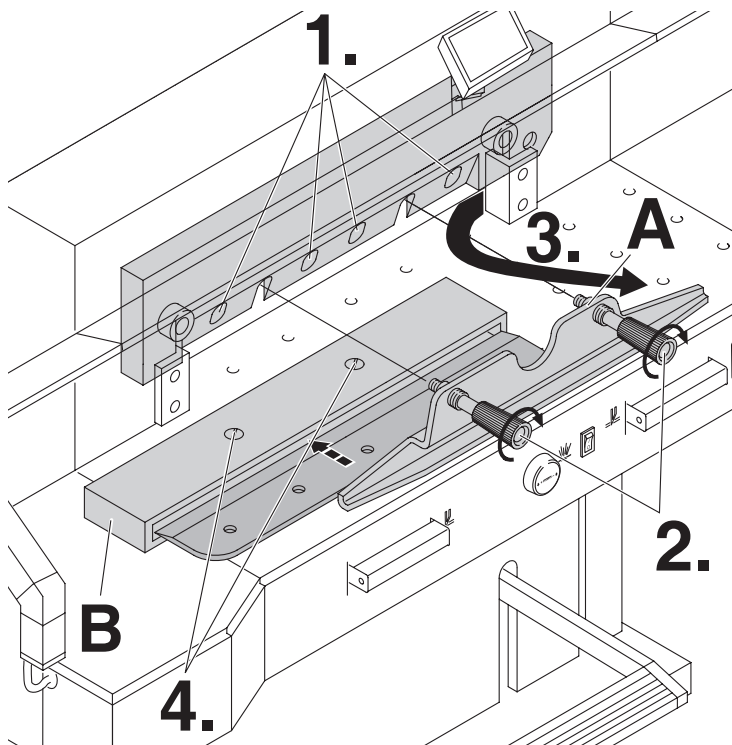

Remove 4 blade screws (1.)
Loosen the grips (2.) of the blade changing tool (A) lightly and allow the blade to be taken downwards out of the machine (3.). Place the blade into the blade carrier (B) and screw it into place (4.).

MyBinding.com
5500 NE Moore Court
Hillsboro, OR 97124
Toll Free: 1-800-944-4573
Local: 503-640-5920

IDEAL 7260

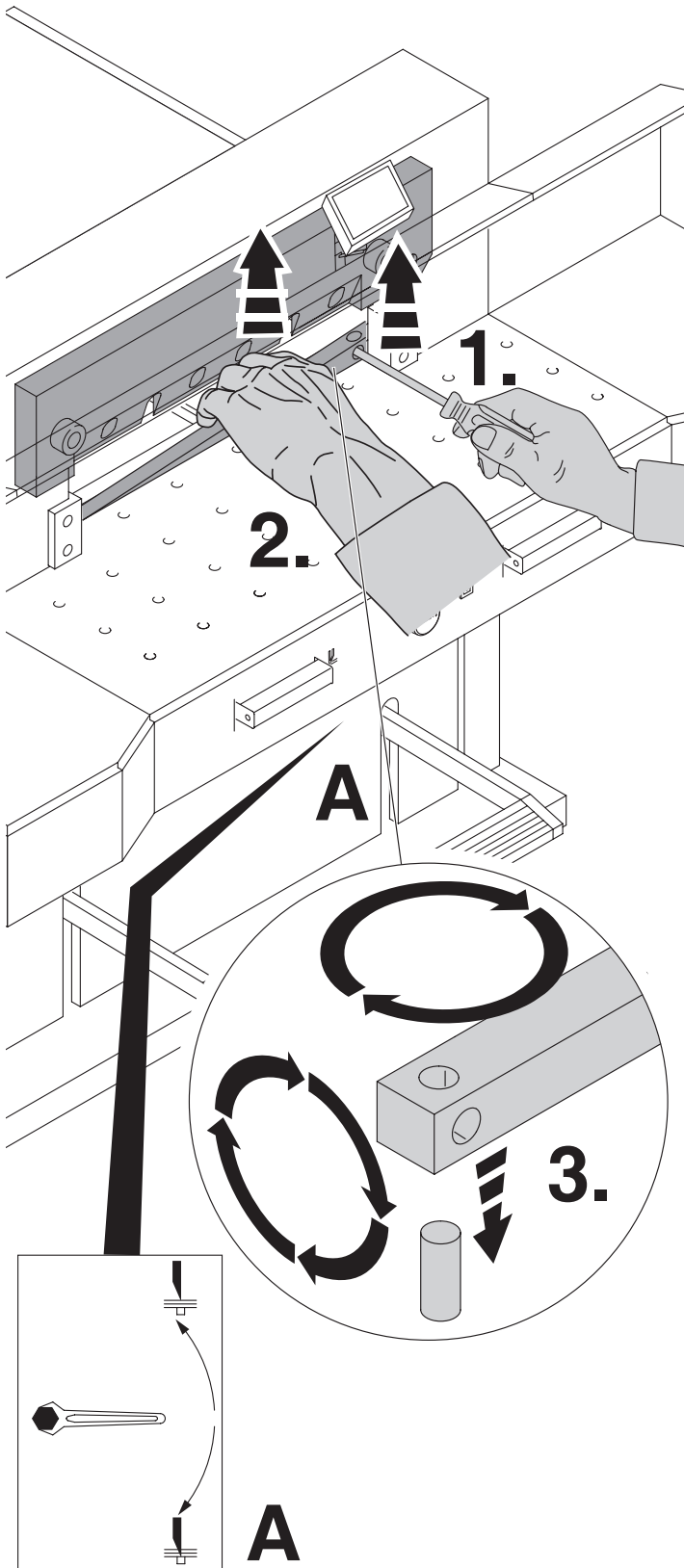

Take out the cutting stick with a small screwdriver. If needed the cutting stick can be turned or exchanged. (The cutting stick can be used eight times).

Replacing the cutting stick (not the blade)

- Turn the blade depth adjustment (A) towards the top until the blade screw recess corresponds with the frame recess. See page 29. (Otherwise the first cut will be too deep).
- **Remove spanner**
- Remove the cutting stick according to top picture.
- Turn the cutting stick (the non-used side must be near to the blade) and plug it into the left holding bolt.

⚠ **Danger!** Risk of injury!

Cutting test after replacing the cutting stick (not the blade)

- Insert the paper and release the cut.
- If the last sheet of paper is not cut along the entire length turn the blade depth adjusting screw (A) 1/12 downwards using a spanner.
- If the last sheet is still not completely cut repeat this process until the last sheet is cut along the entire length.

• Blade and cutting stick replacement •

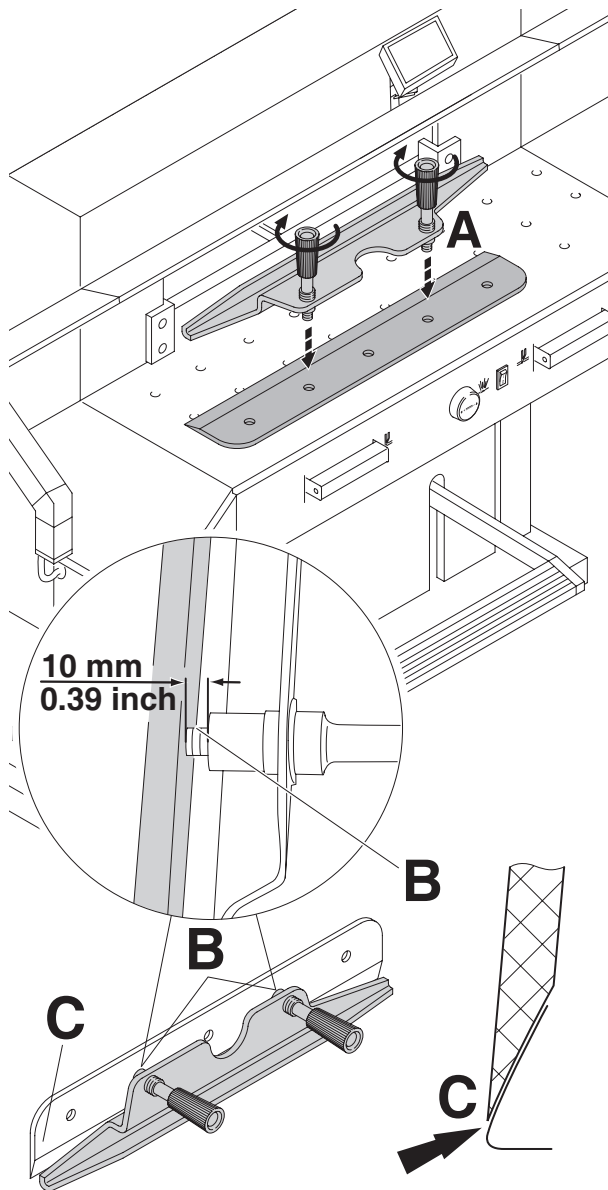

Take the exchange blade carefully out of the blade box and screw it to the blade changing tool (A)

- Make sure there is a space of 10 mm or 0.39 inches! (B).
 - Blade must be covered! (C).
- ⚠ **Danger!** Risk of injury!

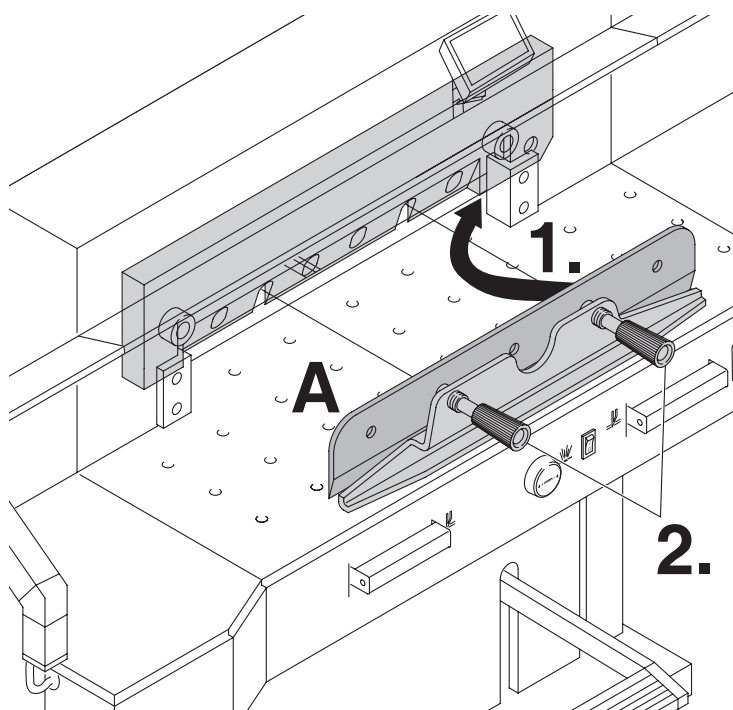

Place the blade to be exchanged with the blade changing tool (A) mounted (1.), into the blade carrier and push it up to the top and screw it into place with the grips (2.).

MyBinding.com
5500 NE Moore Court
Hillsboro, OR 97124
Toll Free: 1-800-944-4573
Local: 503-640-5920

IDEAL 7260

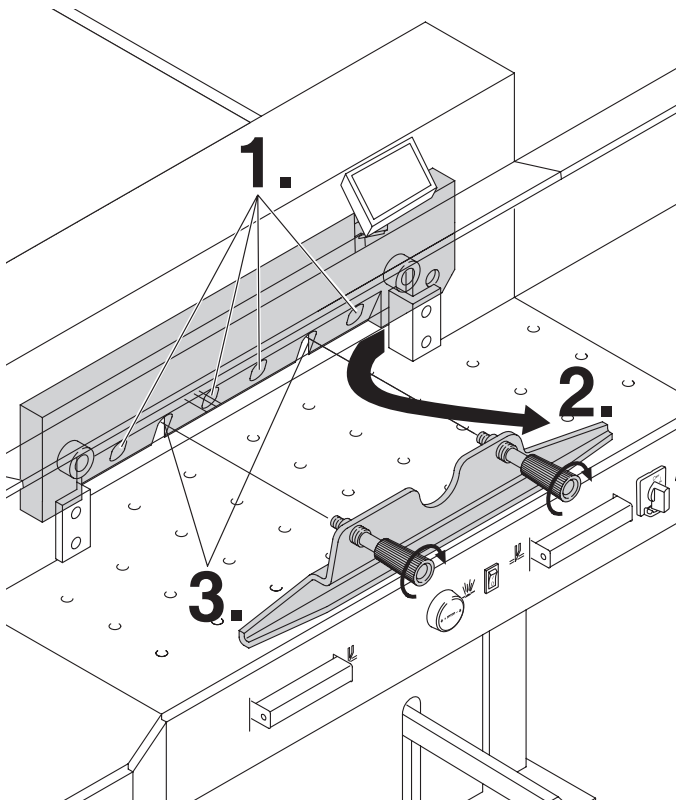

Lightly tighten 4 of the 6 blade screws with washers (1.). Remove the blade changing tool (A) (2.). Lightly tighten the remaining blade screws with washers (3.).

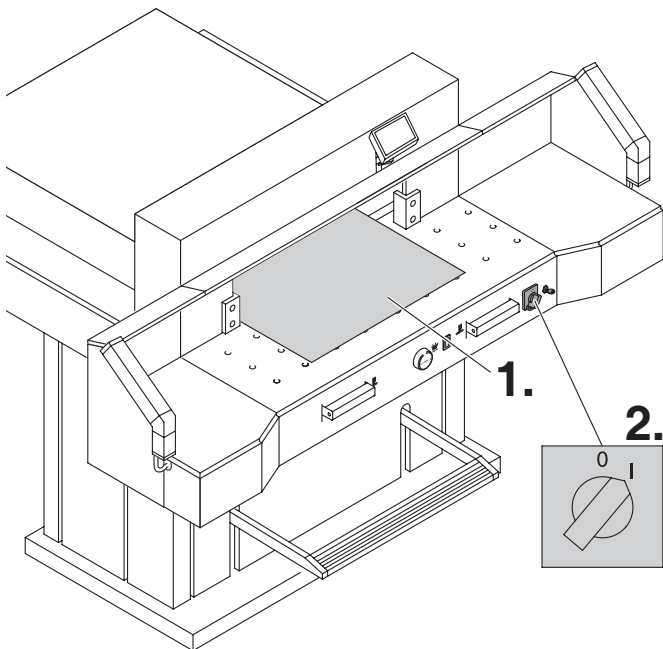

Remove all tools and distribute paper along the entire cutting length (1.). Turn main switch to position "I" (2.).

MyBinding.com
5500 NE Moore Court
Hillsboro, OR 97124
Toll Free: 1-800-944-4573
Local: 503-640-5920

• Blade and cutting stick replacement •

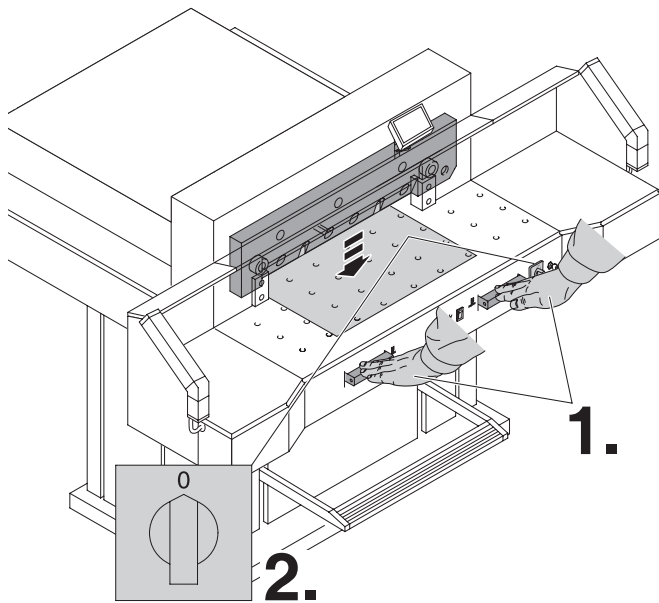

Lower the blade by pressing both cutting buttons (1.). Keep one button pressed and turn off the main switch (2.).

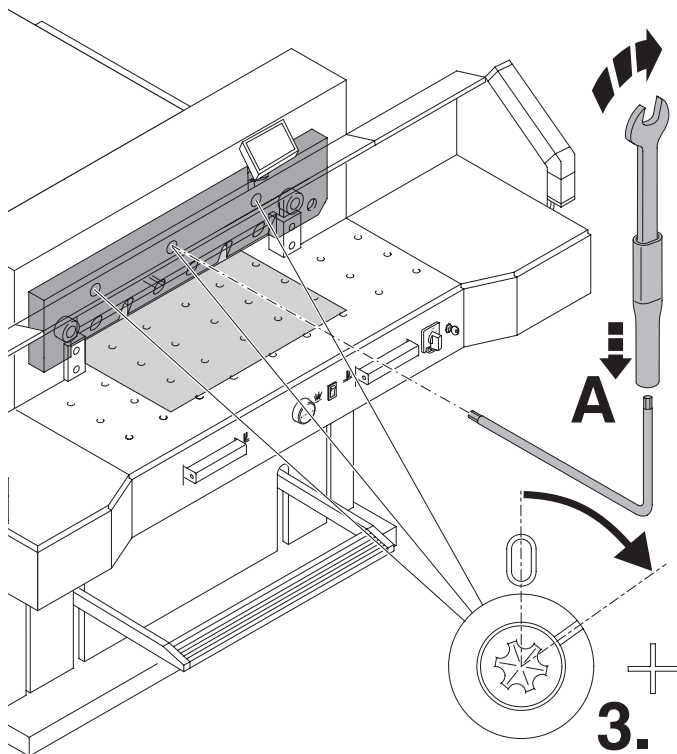

With the special wrench (A) the 3 eccentrics should be screwed down until the paper is cut along the entire length of the blade (3.) (The blade must remain parallel, not too deep into cutting stick).

MyBinding.com
5500 NE Moore Court
Hillsboro, OR 97124
Toll Free: 1-800-944-4573
Local: 503-640-5920

IDEAL 7260

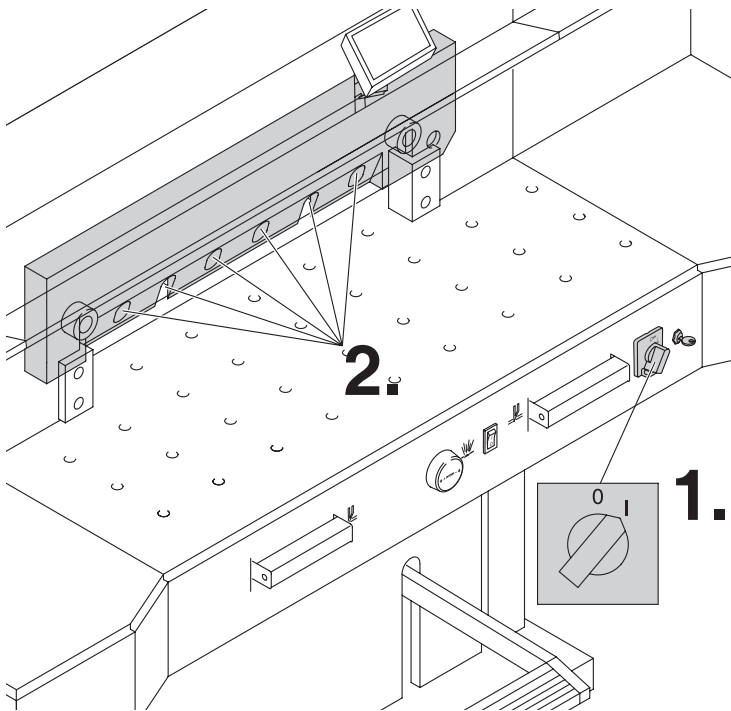

Turn main switch to position "I" (1.). Blade will return to upper position. Tighten 6 blade screws (2.) firmly.

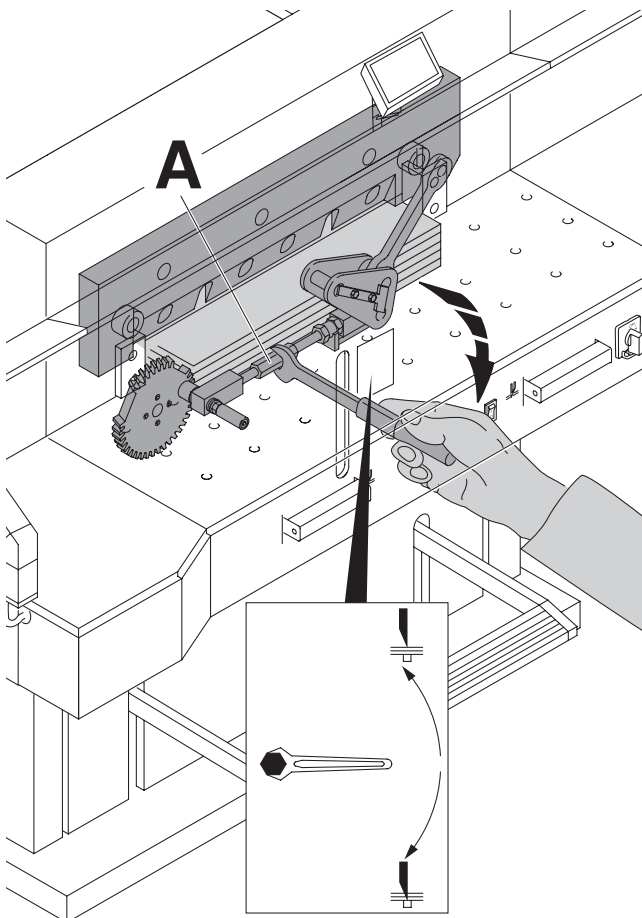

Paper cutting test. If the last sheet or several sheets are not completely cut, gradually turn the blade depth adjustment (A) 1/12 downwards until all the paper is completely cut. Do not set too low as blade will become blunt sooner.

MyBinding.com
5500 NE Moore Court
Hillsboro, OR 97124
Toll Free: 1-800-944-4573
Local: 503-640-5920

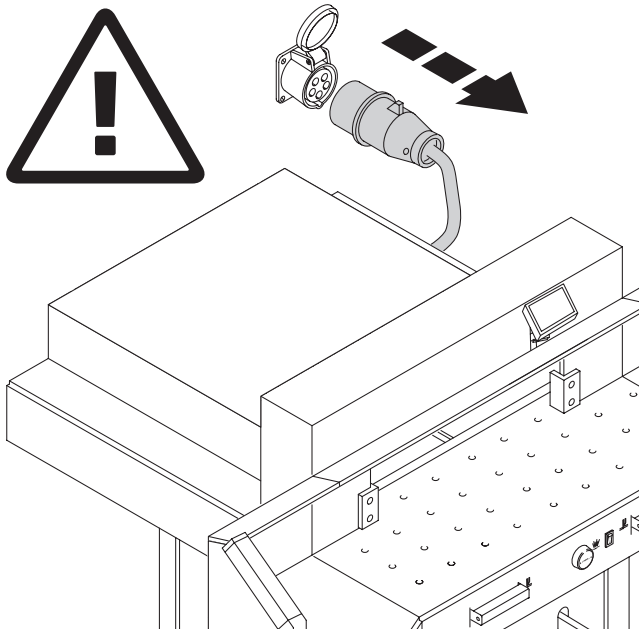

⚠ Danger!

- Maintenance work may only be performed by trained staff.
- Disconnect the mains before starting any service work or before removing the cover.

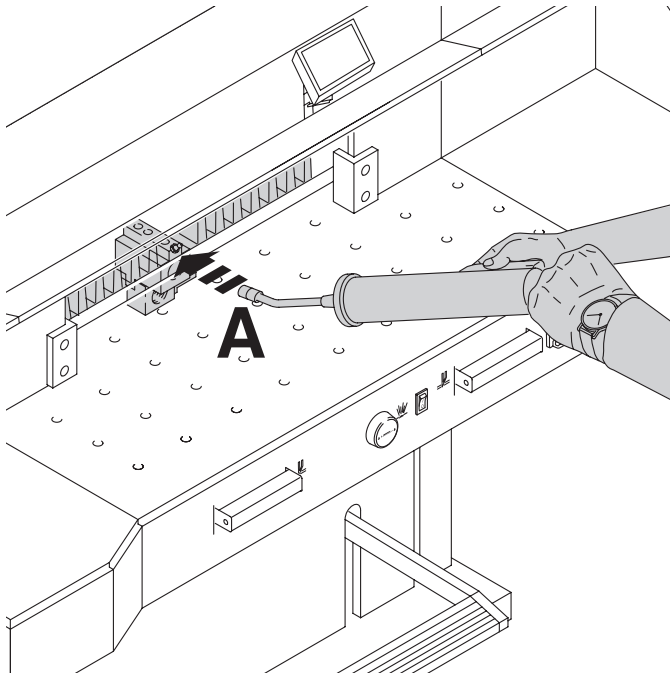

Grease the backgauge (A) control weekly with a grease gun. Advance the backgauge as far as possible to the front. (Use non-resinous oil or grease).

MyBinding.com
5500 NE Moore Court
Hillsboro, OR 97124
Toll Free: 1-800-944-4573
Local: 503-640-5920

IDEAL 7260

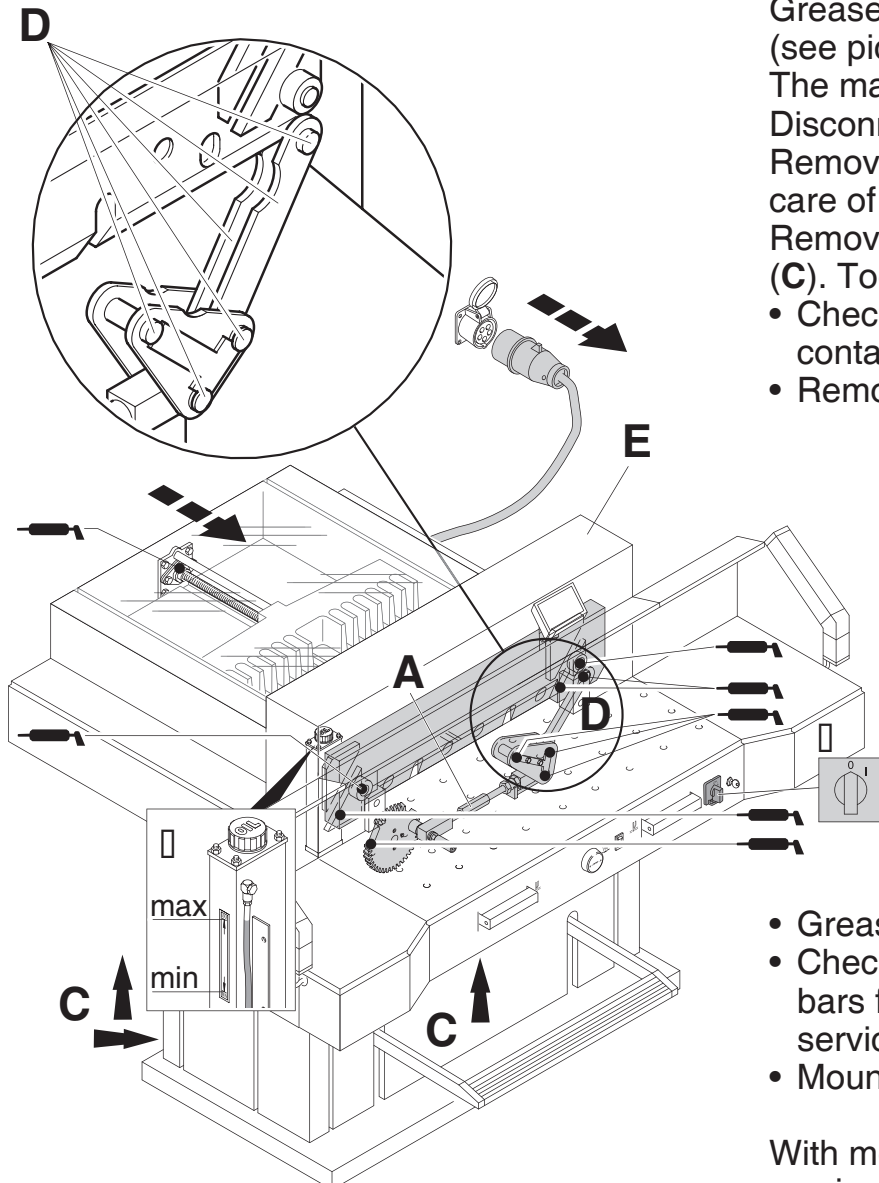

Grease the remaining parts twice a year (see picture).

The main switch must be on "0" (B).

Disconnect from the mains.

Remove the front upper housing (E) → taking care of the cable.

Remove lower panel and rear wooden panel (C). Tools in tool set.

- Check oil (F). If oil is below minimum contact your dealer.
- Remove any paper.

• Grease the machine.

• Check the 4 joining bolts and 2 pushing bars for wear (D). If necessary inform your service personnel.

• Mount the machine.

With more than 5 hours of use per day, the service must be performed more often.

MyBinding.com
5500 NE Moore Court
Hillsboro, OR 97124
Toll Free: 1-800-944-4573
Local: 503-640-5920

Next Maintenance

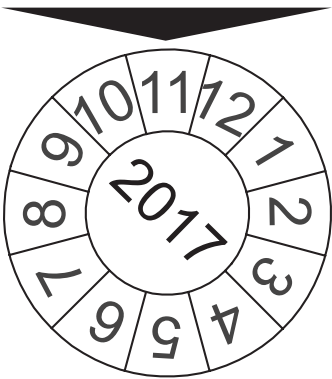

Krug & Priester GmbH & Co. KG
72336 Balingen - Germany

Parts & Service HOTLINE

Germany: +49 7433 2690
France: +33 3 8820 5435
North America: +1 843 552 2700
All other countries: Please contact
your local distributor
www.krug-priester.com

Annual inspection

To maintain the operational safety and to prevent premature wear, we recommend an annual inspection and maintenance of the machine by a qualified service technician.

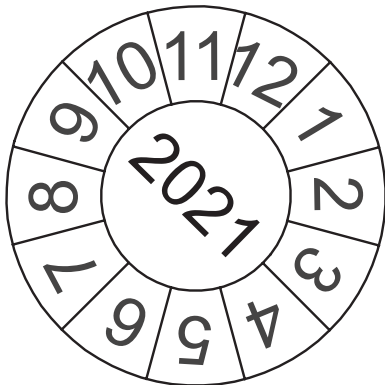

Safety test

The safety regulations are according to the regulations of the country where the cutting machine is operated. The manufacturer recommends a safety check is made every 5 years by an authorised service team.

MyBinding.com
5500 NE Moore Court
Hillsboro, OR 97124
Toll Free: 1-800-944-4573
Local: 503-640-5920

IDEAL 7260



Machine does not function!

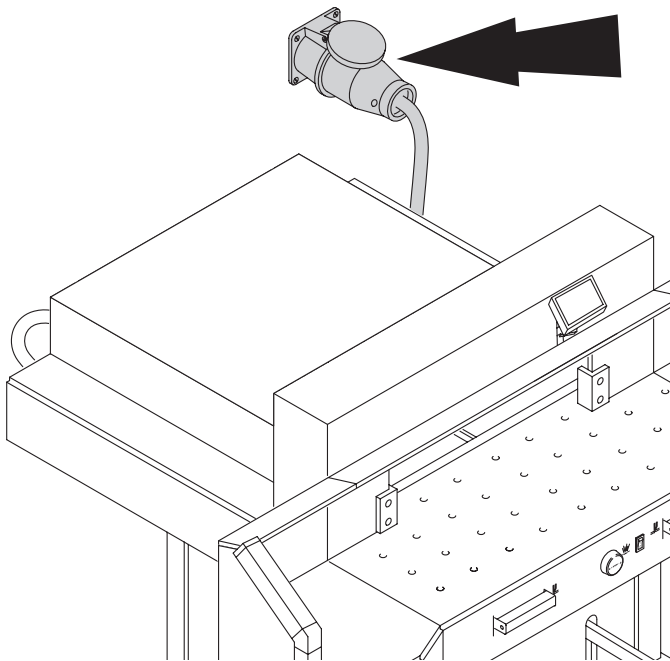

Is the machine plugged in?

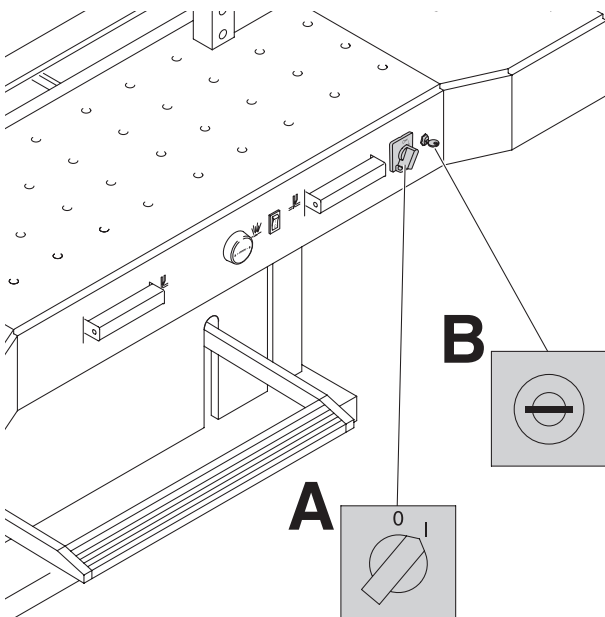

Main switch to position "I"? **(A)**
Control system activated? **(B)**
(Turn key to the right)
Check the units fuse and the on-site circuit breaker!
Release a cut see page 19.

MyBinding.com
5500 NE Moore Court
Hillsboro, OR 97124
Toll Free: 1-800-944-4573
Local: 503-640-5920

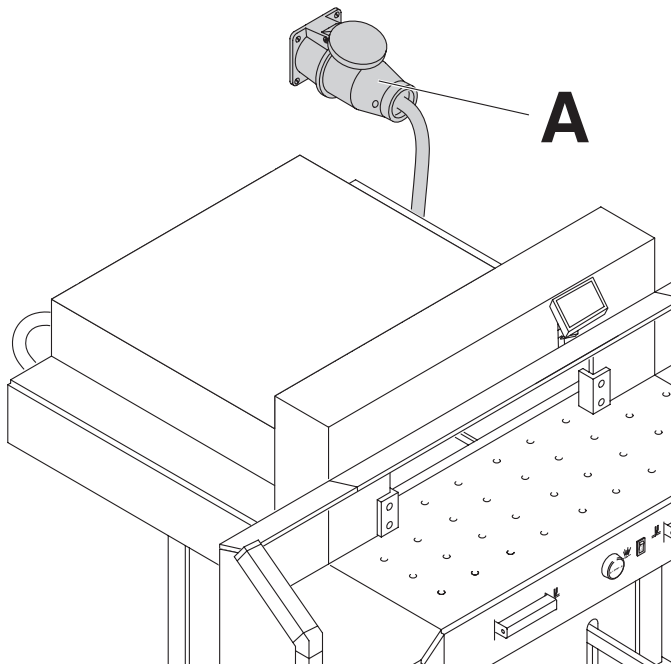

The machine does not function after being moved to another position.

If the machine still does not function then the rotation must be reversed.
The machine is wired according to the IEC standards. We recommend that alterations to the rotary direction be made in the socket. It is also possible to make alterations in the plug by exchanging "L1" and "L2".

⚠ Danger!

Incorrect exchanging of the connections will endanger the operator.
This work must be carried out by an electrician.

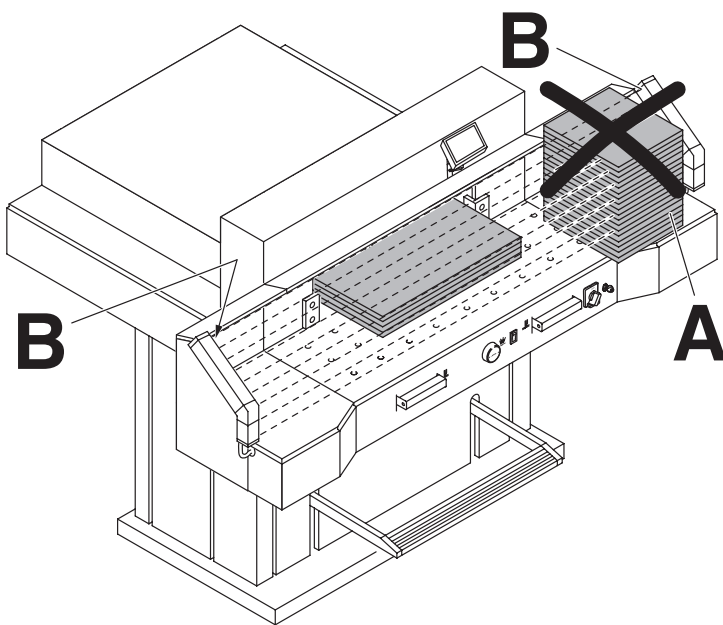

Cut cannot be activated.

- **Safety light beam is interrupted /dirty.**
Remove all items obstructing the safety area (A) and clean the glass from the sender (B) and receiver (B).
- **Measurement has not been reached correctly.**
Push the button again.
- **Measurement below 9 cm.**
The false clamp plate must not be mounted. Remove the false clamp plate and store it in the **provided holder** (see page 18).

MyBinding.com
5500 NE Moore Court
Hillsboro, OR 97124
Toll Free: 1-800-944-4573
Local: 503-640-5920

IDEAL 7260

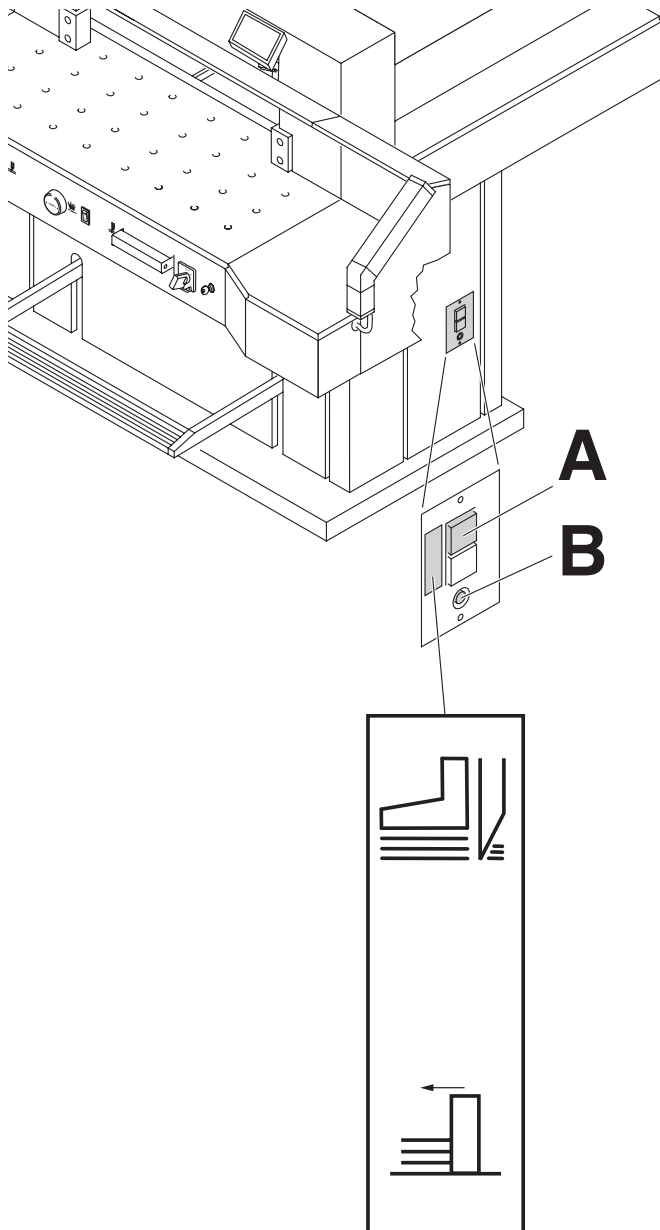

Machine turns off:

- **Machine overloaded.**
Safety button (A) ejects.
Reset the safety button (A).
- **Machine blocked.**
- **Blade is blunt.**
Eliminate the cause, and push the safety button (A).
- **Backgauge blocked**
Safety button (B) ejects.
Eliminate the cause, and push the safety button (B).

Safety button for:

A = Blade drive

B = Backgauge drive

MyBinding.com
5500 NE Moore Court
Hillsboro, OR 97124
Toll Free: 1-800-944-4573
Local: 503-640-5920

• Possible malfunctions •

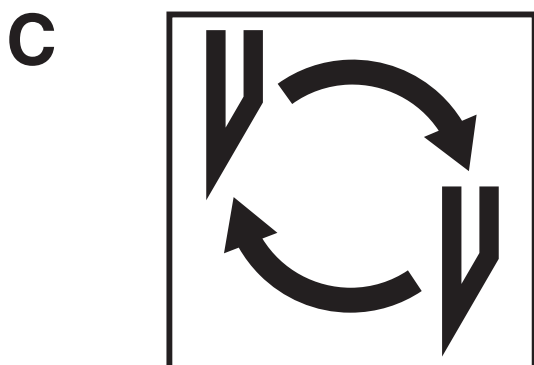
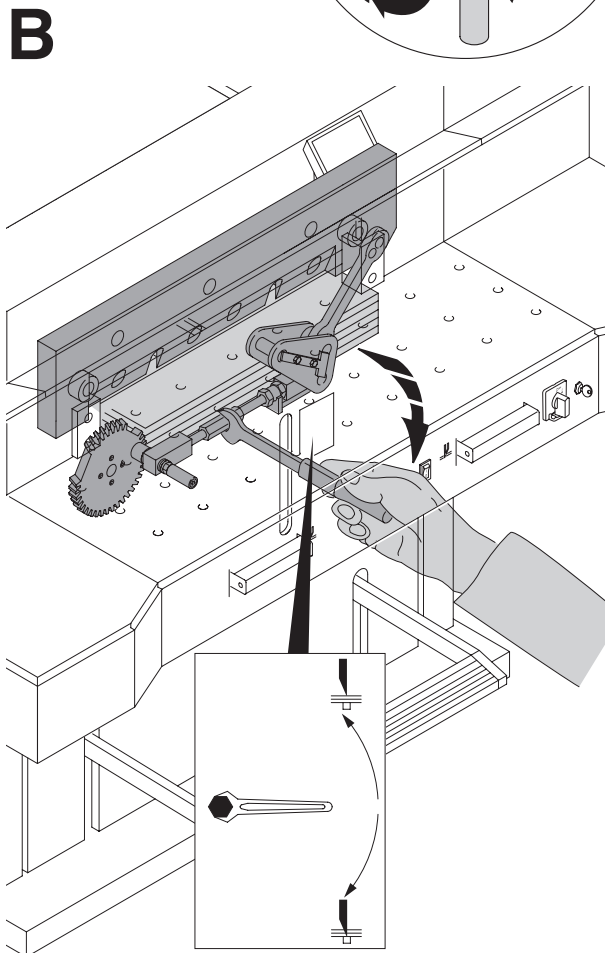
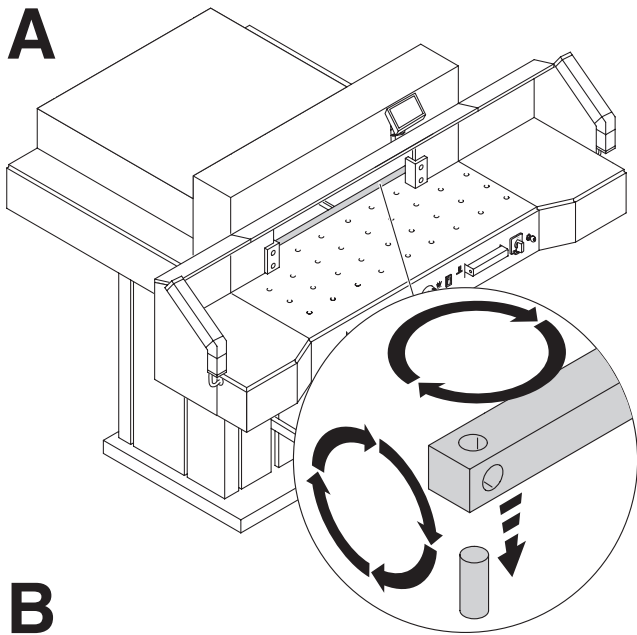

Does not cut through the last sheet:

- Turn or turn around the cutting stick (A), readjust the blade by means of blade depth adjustment (B) (see page 36).

Poor cutting quality or blade stays in the paper stack.

- Change the blade (C) (see pages 28 - 36).

MyBinding.com
5500 NE Moore Court
Hillsboro, OR 97124
Toll Free: 1-800-944-4573
Local: 503-640-5920

IDEAL 7260

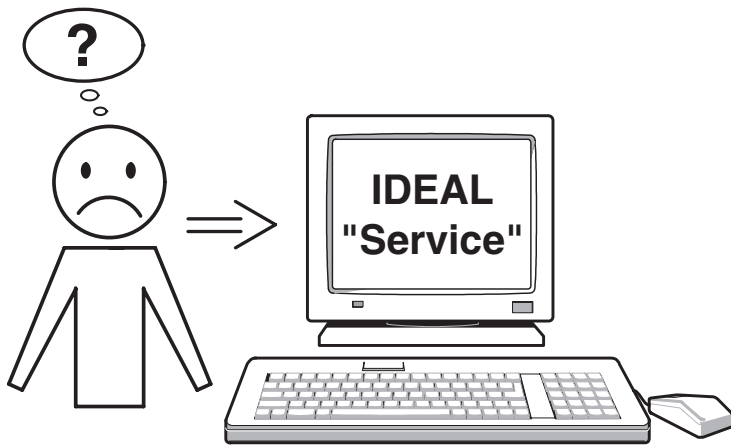

Motor runs but blade does not move downwards.

- Security brake has been activated!
Inform the Service Team!
- www.krug-priester.de → "Service"
service@krug-priester.com

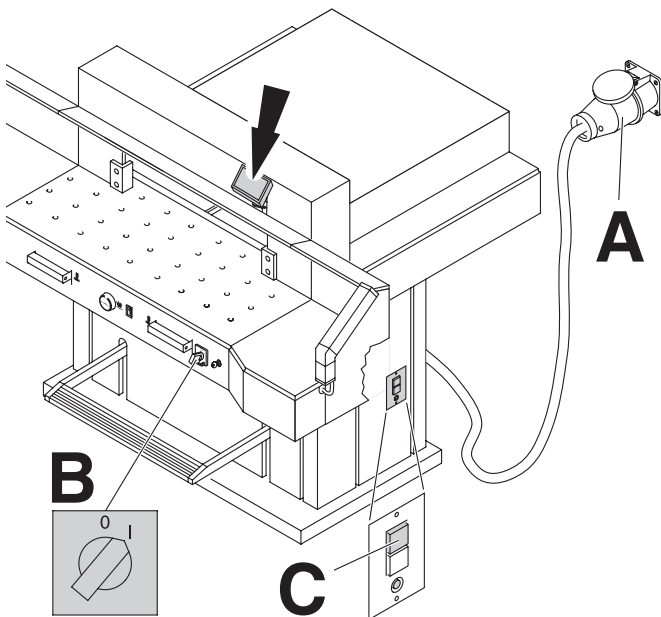

Display illumination off

- Is the machine plugged in? (A)
- Is the main switch on position "I"? (B)
- Push in the green safety button! (C)
- Check the units fuse and the on-site circuit breaker!

MyBinding.com
5500 NE Moore Court
Hillsboro, OR 97124
Toll Free: 1-800-944-4573
Local: 503-640-5920

• Possible malfunctions •

No clamp pressure.

- Hydraulic oil needs refilling (F).
- Contact your dealer.**

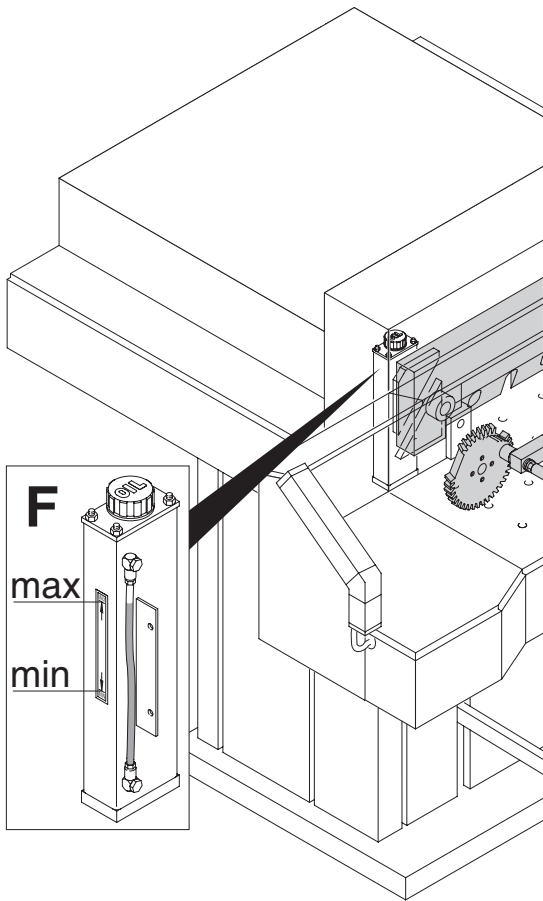

Trouble shooting-light beam

Cut cannot be activated:

- Remove all items obstructing the safety area (A)
- (B) Green = o.k. / ready for operation
Red = light beam is interrupted or error

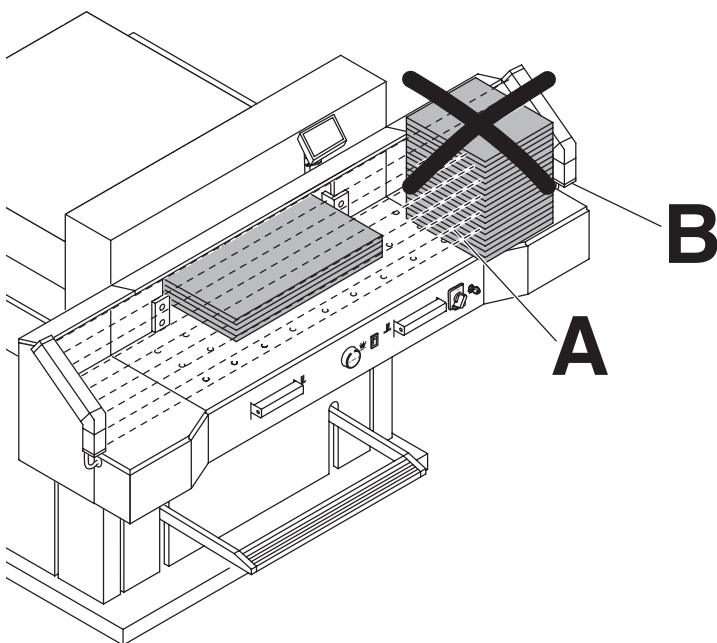

MyBinding.com
5500 NE Moore Court
Hillsboro, OR 97124
Toll Free: 1-800-944-4573
Local: 503-640-5920

IDEAL 7260

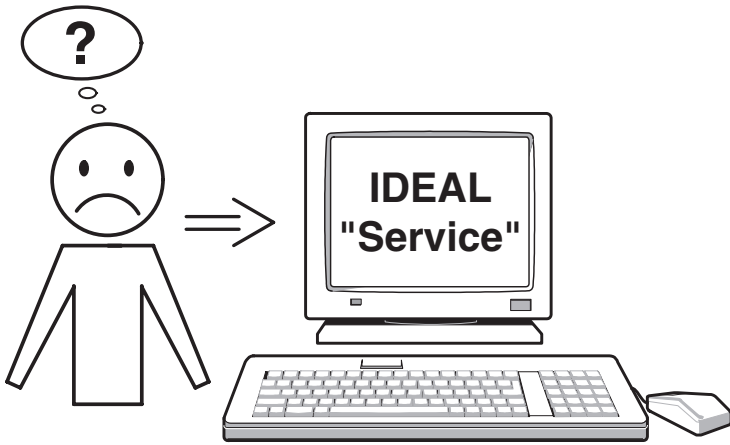

None of the above mentioned methods helped to solve the problem:

Contact Service Team under

- www.krug-priester.de → "Service"
service@krug-priester.com

MyBinding.com
5500 NE Moore Court
Hillsboro, OR 97124
Toll Free: 1-800-944-4573
Local: 503-640-5920

Recommended accessories:

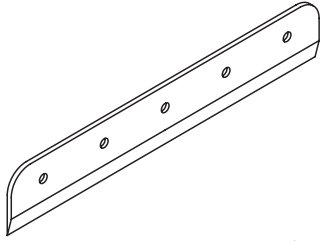

HSS - Blade

- No. 9000 141

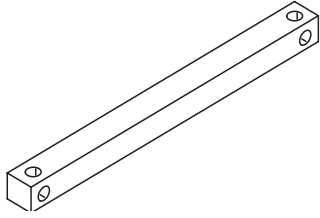

Cutting stick (6 pieces)

- No. 9000 039

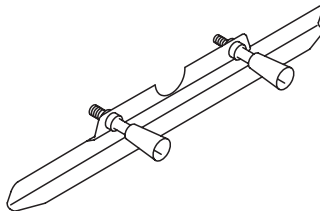

Blade changing tool ¹

- No. 9000 514

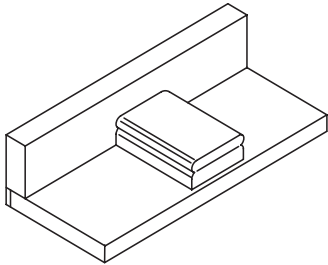

Paper knock-up block ¹

- No. 9000 521

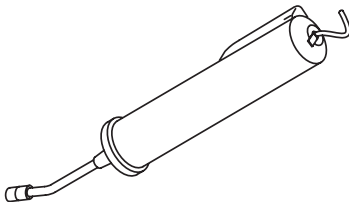

Grease gun ¹

- No. 9004 683

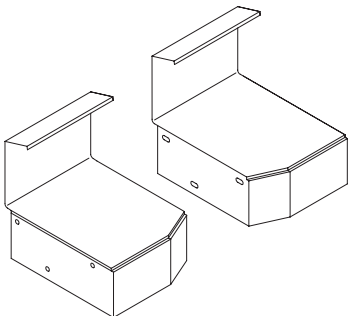

Side tables left and right

- No. 9000 550

MyBinding.com
5500 NE Moore Court
Hillsboro, OR 97124
Toll Free: 1-800-944-4573
Local: 503-640-5920

¹ Included in delivery

IDEAL 7260

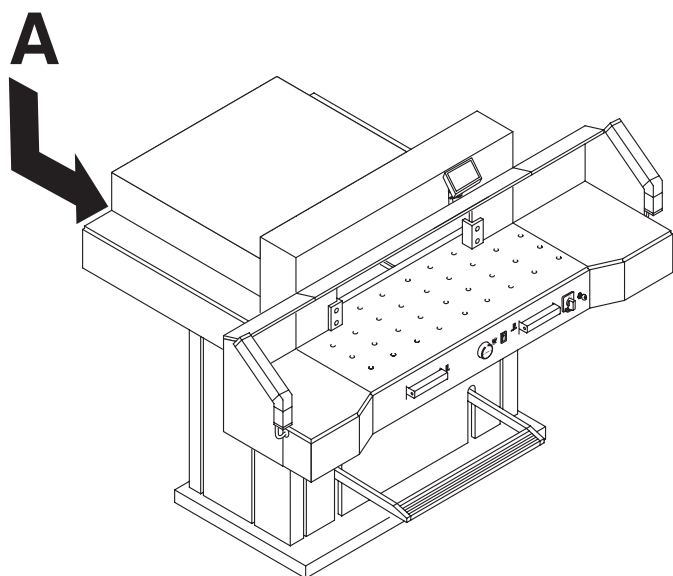

Technical data:

- Power supply: 400V/50Hz/3~, 220V/60Hz/3~
- Cutting length: 720 mm
- Cutting height: 80 mm
- Table depth: 720 mm
- Sound level EN 13023: 72 dB (A)
- Minimum space requirement (width x depth x height)
1305/2100¹mm x 1540/1600¹mm x 1335 mm
- Leakage current < 3,5mA
- Power cord gauge min. 1,5mm² (400V)
- Power cord gauge AWG 14 (20A) (220V)
- Clamping pressure: min. 250 daN, max 2000 daN
- Weight: 588 kg, 628 kg¹
- Capacity of hydraulic oil: 1,5 l
HLPD, viscosity 46 mm²/ sec. to DIN 51562.
Used oil must be disposed of at the authorised place.

¹ with side tables

The exact technical specifications can be found on the technical specifications sticker (**A**) on the machine. A wiring diagram is found in the electrical switch box.

To claim under guarantee, the machine must still carry its original identification label.

Safety light beam

- Total reaction time: 120 ms
- Resolution 14 mm/minimum distance: 250 mm
- Resolution 24 mm/minimum distance: 320 mm
- Resolution 39 mm/minimum distance: 440 mm

Ambient operating temperature 10 °C - 60 °C
Air humidity (not condensating) 15 % - 95 %

MyBinding.com
5500 NE Moore Court
Hillsboro, OR 97124
Toll Free: 1-800-944-4573
Local: 503-640-5920



The company Krug + Priester has the following certifications:

- Quality management system according to DIN EN ISO 9001:2008
- Environmental management system according to DIN EN ISO 14001:2009
- Energy management system according to DIN EN ISO 50001:2011



MyBinding.com
5500 NE Moore Court
Hillsboro, OR 97124
Toll Free: 1-800-944-4573
Local: 503-640-5920

IDEAL 7260



This machine is approved by independent safety laboratories and is in compliance with the EC-regulations 2006/42/EG and 2014/30/EG.

Sound level information:

The sound level is 72 db (A) as defined by EN 13023.

Subject to alteration without notice.



I.T.E. Listed 802 D

MyBinding.com
5500 NE Moore Court
Hillsboro, OR 97124
Toll Free: 1-800-944-4573
Local: 503-640-5920

IDEAL • Made in Germany

MyBinding.com
5500 NE Moore Court
Hillsboro, OR 97124
Toll Free: 1-800-944-4573
Local: 503-640-5920

• Document Shredders •



• Trimmers and Guillotines •

