

L-SERIES  
**WHEEL LOADERS**



**JOHN DEERE**

524L / 544L / 624L



**VERSATILITY MEETS  
CAPABILITY**

# ASPIRE TO GO



**MORE  
SPACIOUS  
CAB\***

+



**EASY-TO-USE  
ELECTROHYDRAULIC  
CONTROLS**

+



**NEW  
FRONT-END  
FEATURES**

*\*Compared to our K-Series models.*

THE NEW L-SERIES

**HIGHER.**





## ***ELEVATE YOUR EXPECTATIONS.***

Combining new front-end features that dramatically boost productivity with an all-new cab and controls, our 524L, 544L, and 624L Loaders redefine your expectations of what a utility loader can do. Enhancements over previous models include near-parallel lift, a more spacious cab, ergonomic controls, and new bucket and linkage designs. Plus a host of details that improve uptime, including reimaged electrical and hydraulic routing, for performance and reliability that can elevate your operation to a higher level.

# NEW FRONT-END FEATURES AND MORE **MEET THE NEW FRONT-RUNNERS.**

L-Series Loaders lead the way with new production-boosting features up front, along with a host of other enhancements that help dramatically increase performance.

## **More performance up front**

Boasting new bucket and linkage designs that improve load leveling, material retention, and visibility, these loaders deliver more productivity and performance than previous models.

## **Enhanced production buckets**

A wide selection of enhanced production buckets with integrated spill guards, curved side cutters, and greater rollback delivers better bucket-fill performance and material retention.

## **Redesigned cab**

New operator station is more spacious and comfortable, and features extra legroom, an improved HVAC system, additional storage, and a more adjustable seat. Or opt for a premium cab with a larger monitor and a heated and ventilated premium seat.

## **New EH controls**

Seat-mounted right-hand joystick features two programmable multifunction buttons and new electrohydraulic (EH) controls that are more intuitive to operate compared to our K-Series controls.



**8° OF PARALLELISM**  
VS. 21° ON K-SERIES

# GO ABOVE AND BEYOND LOAD MORE.

Boasting near-parallel lift along with new High-Lift Plus and Tool Carrier configurations, these versatile loaders put more productivity within reach.

### Standard Z-Bar with parallel lift

Lift path on all Z-Bar linkages has been improved to near parallel for better load-leveling capability. This boosts productivity by minimizing load rollback, reducing material spillage, and requiring fewer manual adjustments.

### New Tool Carrier configuration

Tool Carrier configuration on the 524L and 624L enables a clear view of the coupler and forks, making it easier to quickly move pipes, logs, and pallets.

### Improved visibility to front tool

Cross-tube and boom geometry of the Z-Bar linkage has been streamlined to provide a better view to the front attachment.

### New High-Lift Plus configuration

Need even more reach for dumping into higher feeders, hoppers, trucks, and wagons? New High-Lift Plus configuration provides an additional 24 inches in hinge-pin height over standard lift height and 12 inches over the High-Lift model. All three lift heights feature near-parallel lift.





TAKE PRODUCTIVITY TO  
***NEW HEIGHTS.***

# TONS OF COMFORT

## TAKE A LOAD OFF.

With redesigned cab and controls, more storage and power ports, and a better HVAC system than earlier models, L-Series Loaders make it easy to work harder with less effort.

### Get in and get comfortable

All-new cab boasts three more inches of legroom than previous models. Joystick controls, foot pedals, and sealed-switch module are all ergonomically placed for optimal comfort and convenience. Additional 12-volt and USB power ports and mounting points keep all your devices charged up and within easy reach.

### Stowaway storage

HVAC system has been relocated outside the cab to provide more storage area. There's plenty of space for a powered cooler, along with a handy 12-volt outlet. There's also a Thermos® holder with a Velcro® strap, plus a conveniently placed cupholder. There are even coat hooks.

### Sit back and relax

Updated in stain-resistant cloth, the standard high-back air-ride seat is even more adjustable, for daylong comfort and support. Or choose the optional heated and ventilated premium seat (standard in the premium cab) with heavy-duty air suspension and adjustable seat pan for even more comfort.

### Keep things cool

HVAC system is easier to maintain, with convenient filter and service locations. Brushless motor is more reliable and provides infinite fan speeds, quieter operation, and improved airflow. Blower vent behind the seat further improves airflow and defrosts the rear window. Premium cab features automatic temperature control (ATC).

### See more, do more

Improved visibility to the work tool helps reduce spillage, cycle times, and tool-changeover time. It also helps minimize machine damage when working on crowded jobsites or up against walls.

### Multi-language color LCD display

A large seven-inch in-cab display with easy-on-the-eyes clarity enables intuitive push-button access to key info. Standard rearview camera displays the activity behind the machine on the LCD screen. Add a dedicated seven-inch rearview display to see the action behind and still have access to vital machine data at all times.







**3" MORE  
LEGROOM**  
THAN K-SERIES CABS



## ***MORE PRODUCTIVITY, HANDS DOWN***

***GET IN TOUCH WITH YOUR PRODUCTIVE SIDE.***

With redesigned joysticks and expanded, customizable electrohydraulic (EH) controls, maximum productivity is close at hand in an L-Series Loader.

---

### **Integrated joystick control**

Operators can easily control up to six functions without removing their hand from the ergonomically designed joystick. A larger F-N-R button provides convenient direction and full-range gear changes. Two industry-exclusive multifunction buttons can each be programmed to handle any of 10 functions selected through the monitor.

### **Single-axis controls**

New low-effort, short-throw control includes two multifunction buttons on the bucket lever that can be programmed to handle any of 10 functions.



## 2 INDUSTRY- EXCLUSIVE MULTIFUNCTION JOYSTICK BUTTONS

### Expanded EH functionality

Operators can easily enable the following EH functions using the multifunction buttons and adjust them through the monitor:

- **Soft or hard hydraulic stops** for both the boom and bucket can be enabled to prolong machine life or temporarily disabled when the application calls for it.
- **Hydraulic-function flow** can be used to customize flow for specific attachments without needing special plumbing or valves.
- **Bucket vibrate** creates a slight vibration when dumping loose materials into hoppers or feeders, or when sprinkling rock over pipe.
- **EH Precision mode** allows fine metering of the bucket and boom when precise movement is required, for example, laying pipe, moving heavy objects such as road barriers, or placing manholes.
- **Attachment configuration** allows settings such as hydraulic flow and responsiveness for up to 10 different attachments to be conveniently stored.

### New SSM functionality

Sealed-switch module (SSM) has been repositioned under the monitor so it's in the operator's line of sight. Updated or new functions include:

- **Return-to-dig** now allows leveling of the bucket from both dump and curl positions, for quick and easy leveling.
- **Constant-flow hydraulics** allow the operator to continuously run attachments without having to hold a lever or roller at full stop.
- **Throttle lock** maintains a specified rpm so the operator can warm up a machine, run a continuous-flow attachment, or road the machine without having to hold the throttle pedal down.

# TIGHTFISTED

*EASYGOING ABOUT EVERYTHING BUT THE BOTTOM LINE.*

## **Reliable electrical and hydraulic systems**

Routing for electrical wire harnesses and hydraulic hoses has been improved over the K-Series to reduce rubbing and eliminate leak points, boosting durability and reliability.

## **Same-side ground-level service**

All daily service points including fuel are conveniently grouped on the left side of the machine for easy access.

## **Innovative Quad-Cool™ system**

Quad-Cool places the radiator, air-conditioner condenser, intercooler, and hydraulic, transmission, and axle coolers (standard on the 624L, optional on the 524L and 544L) in a unique boxed configuration that's isolated from engine heat, boosting efficiency and durability.

## **Diagnostic messaging**

Easy-to-navigate LCD monitor displays diagnostic messages if problems occur and even offers possible solutions to help get you back up and running quickly.

## **Efficient cooling**

Hydraulically driven fan runs only as needed for better cooling and fuel efficiency. Optional programmable fan automatically reverses at predetermined intervals to eject debris from the radiator and cooler cores. Or set individual cleaning cycles through the monitor.



---

Get valuable insight with

**JOHN DEERE WORKSIGHT™**

The John Deere WorkSight suite of construction technology delivers **Productivity Solutions** to help you get more done, more efficiently. The in-base, five-year JDLink™ telematics subscription provides machine location, utilization data, and alerts to help you maximize productivity and efficiency. Other productivity solutions including grade-management and payload-weighting options are also available.

To maximize uptime and lower costs, JDLink telematics also enables **John Deere Connected Support™**. John Deere's centralized Machine Health Monitoring Center analyzes data from thousands of connected machines, identifies trends, and develops recommended actions, called Expert Alerts, to prevent downtime. Dealers use Expert Alerts to proactively address conditions that may otherwise likely lead to downtime. Your dealer can also monitor machine health and leverage remote diagnostics and programming capability to further diagnose problems and even update machine software without a time-consuming trip to the jobsite.





# 524L SPECIFICATIONS

While general information, pictures, and descriptions are provided, some illustrations and text may include product options and accessories NOT AVAILABLE in all regions, and in some countries products and accessories may require modifications or additions to ensure compliance with the local regulations of those countries.

<b>Engine</b>			
<b>524L Z-BAR / HIGH-LIFT / HIGH-LIFT PLUS / TOOL CARRIER</b>			
Manufacturer and Model	John Deere PowerTech™ PVS 6068	Gross Peak Torque (ISO 9249)	713 Nm (526 ft.-lb.) at 1,400 rpm
Non-Road Emission Standard	EPA Final Tier 4/EU Stage V	Net Torque Rise	60%
Cylinders	6	Fuel System (electronically controlled)	High-pressure common rail
Valves Per Cylinder	4	Lubrication	Full-flow spin-on filter and integral cooler
Displacement	6.8 L (414 cu. in.)	Aspiration	Turbocharged, charge air cooled
Net Peak Power (ISO 9249)	113 kW (152 hp) at 1,800 rpm	Air Cleaner	Under-hood, dual-element dry type, restriction indicator in cab monitor for service
Gross Peak Power (ISO 9249)	120 kW (161 hp) at 1,800 rpm		
Net Peak Torque (ISO 9249)	683 Nm (504 lb.-ft.) at 1,100 rpm		
<b>Cooling</b>			
Fan Drive	Hydraulically driven, proportionally controlled, fan aft of coolers		
<b>Electrical</b>			
Electrical System	24 volt with 100-amp alternator (optional 130-amp alternator)		
Batteries (2 – 12 volt)	950 CCA (each)		
<b>Transmission System</b>			
Type	Countershaft-type PowerShift™		
Torque Converter	Single stage, single phase		
Shift Control	Electronically modulated, adaptive, load and speed dependent		
Operator Interface	Steering-column or joystick-mounted F-N-R and gear-select lever; Quick-Shift button on hydraulic lever		
Shift Modes	Manual/auto (1st-D or 2nd-D); Quick-Shift button with 2 selectable modes: kick-down or kick-up/down; and 4 clutch cutoff settings		
	<i>Standard 5-Speed</i>		
Maximum Travel Speeds (with 20.5 R 25 tires)	<i>Forward</i>	<i>Reverse</i>	
Range 1	5.6 km/h (3.5 mph)	5.9 km/h (3.6 mph)	
Range 2	11.0 km/h (6.8 mph)	11.6 km/h (7.2 mph)	
Range 3	17.0 km/h (10.6 mph)	27.0 km/h (16.8 mph)	
Range 4	25.6 km/h (15.9 mph)	N/A	
Range 5	40.0 km/h (24.8 mph)	N/A	
<b>Axles/Brakes</b>			
Final Drives	Heavy-duty inboard-mounted planetary		
Differentials	Hydraulic locking front with conventional rear – standard; dual locking front and rear – optional		
Rear Axle Oscillation, Stop to Stop (with 20.5 R 25 tires)	24 deg. (12 deg. each direction)		
Brakes (conform to ISO 3450)			
Service	Hydraulically actuated, spring-retracted, self-adjusting inboard sun-shaft mounted, oil cooled, single disc		
Parking	Automatic spring applied, hydraulically released, driveline mounted, sealed wet multi disc		
<b>Tires/Wheels (see page 18 for complete tire adjustments)</b>			
	<i>Tread Width</i>	<i>Width Over Tires</i>	
Michelin 20.5 R 25, 1 Star L-3 XHA2	1952 mm (76.8 in.)	2546 mm (100.2 in.)	
<b>Serviceability</b>			
<b>Refill Capacities</b>			
Fuel Tank (with lockable cap)	220 L (58 gal.)	Axle Oil (each)	
Cooling System	29.9 L (31.6 qt.)	Front	16.6 L (17.5 qt.)
Diesel Exhaust Fluid (DEF)	15.6 L (16.5 qt.)	Rear	18 L (19 qt.)
Engine Oil with Vertical Spin-On Filter	19.5 L (20.6 qt.)	Hydraulic Reservoir and Filter	82.1 L (21.7 gal.)
Transmission Reservoir with Vertical Filter	21 L (22.2 qt.)	Park Brake Oil (wet disc)	0.3 L (10 oz.)
<b>Hydraulic System/Steering</b>			
Pump (loader and steering)	Variable-displacement, axial-piston pump; closed-center, pressure-compensating system		
Maximum Rated Flow at 6895 kPa (1,000 psi) and 2,200 rpm	178 L/m (47 gpm)		
System Relief Pressure (loader and steering)	24 994 kPa (3,625 psi)		
Loader Controls	2-function valve, joystick control or fingertip controls, hydraulic-function enable/disable, optional 3rd- and 4th-function valve with auxiliary lever		
Steering (conforms to ISO 5010)	Steering-column-mounted, twist-grip shift lever; Quick-Shift button on hydraulic lever		
Type	Power, fully hydraulic		
Articulation Angle	80-deg. arc (40 deg. each direction)		
Turning Radius (measured to centerline of outside tire)	5.0 m (16 ft. 5 in.)		
Hydraulic Cycle Times	<i>Z-Bar / High-Lift / High-Lift Plus</i>	<i>Tool Carrier</i>	
Raise	6.1 sec.	5.8 sec.	
Dump	2.0 sec.	2.2 sec.	
Lower (power down)	4.0 sec.	3.5 sec.	
Total	12.1 sec.	11.5 sec.	

# 524L SPECIFICATIONS



While general information, pictures, and descriptions are provided, some illustrations and text may include product options and accessories NOT AVAILABLE in all regions, and in some countries products and accessories may require modifications or additions to ensure compliance with the local regulations of those countries.

## Dimensions and Specifications with Pin-On Bucket 524L Z-BAR / HIGH-LIFT / HIGH-LIFT PLUS / TOOL CARRIER

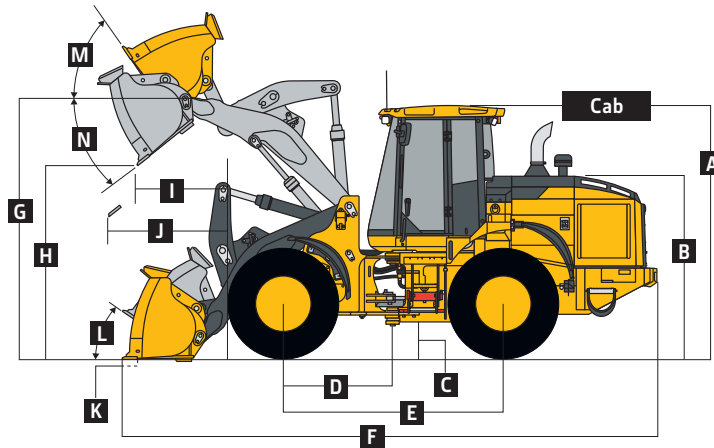

524L Z-BAR / HIGH-LIFT / HIGH-LIFT PLUS LOADERS WITH PIN-ON BUCKET WITH BOLT-ON EDGE

	Z-Bar 2.1-m <sup>3</sup> (2.75 cu. yd.) <i>general purpose</i>	Z-Bar 2.3-m <sup>3</sup> (3.0 cu. yd.) <i>general purpose</i>	High-Lift 2.1-m <sup>3</sup> (2.75 cu. yd.) <i>general purpose</i>	High-Lift Plus 2.1-m <sup>3</sup> (2.75 cu. yd.) <i>general purpose</i>
<b>Dimensions with Bucket with Bolt-On Edge</b>				
A Height to Top of Cab	3.33 m (10 ft. 11 in.)	3.33 m (10 ft. 11 in.)	3.33 m (10 ft. 11 in.)	3.33 m (10 ft. 11 in.)
B Hood Height	2.375 m (7 ft. 9 in.)	2.375 m (7 ft. 9 in.)	2.375 m (7 ft. 9 in.)	2.375 m (7 ft. 9 in.)
C Ground Clearance	0.40 m (15.7 in.)	0.40 m (15.7 in.)	0.40 m (15.7 in.)	0.40 m (15.7 in.)
D Length from Centerline to Front Axle	1.45 m (4 ft. 9 in.)	1.45 m (4 ft. 9 in.)	1.45 m (4 ft. 9 in.)	1.45 m (4 ft. 9 in.)
E Wheelbase	2.93 m (9 ft. 7 in.)	2.93 m (9 ft. 7 in.)	2.93 m (9 ft. 7 in.)	2.93 m (9 ft. 7 in.)
F Overall Length, Bucket on Ground	7.37 m (24 ft. 2 in.)	7.45 m (24 ft. 5 in.)	7.80 m (25 ft. 7 in.)	8.10 m (26 ft. 7 in.)
G Height to Hinge Pin, Fully Raised	3.81 m (12 ft. 6 in.)	3.81 m (12 ft. 6 in.)	4.17 m (13 ft. 8 in.)	4.42 m (14 ft. 6 in.)
H Dump Clearance, 45 deg., Full Height	2.78 m (9 ft. 1 in.)	2.72 m (8 ft. 11 in.)	3.14 m (10 ft. 4 in.)	3.39 m (11 ft. 1 in.)
I Reach, 45-deg. Dump, Full Height	0.99 m (3 ft. 3 in.)	1.04 m (3 ft. 5 in.)	1.09 m (3 ft. 7 in.)	1.12 m (3 ft. 8 in.)
J Reach, 45-deg. Dump, 2.13-m (7 ft. 0 in.) Clearance	1.44 m (4 ft. 9 in.)	1.47 m (4 ft. 10 in.)	1.81 m (5 ft. 11 in.)	2.03 m (6 ft. 8 in.)
K Maximum Digging Depth	102 mm (4.0 in.)	108 mm (4.3 in.)	193 mm (7.6 in.)	198 mm (7.8 in.)
L Maximum Rollback at Ground Level	44 deg.	44 deg.	48 deg.	49 deg.
M Maximum Rollback, Boom Fully Raised	60 deg.	60 deg.	60 deg.	61 deg.
N Maximum Bucket Dump Angle, Fully Raised	50 deg.	50 deg.	46 deg.	45 deg.
Loader Clearance Circle, Bucket Carry Position	11.40 m (37 ft. 5 in.)	11.42 m (37 ft. 6 in.)	11.68 m (38 ft. 4 in.)	12.08 m (39 ft. 7 in.)
<b>Specifications with Bucket with Bolt-On Edge</b>				
Capacity, Heaped	2.1 m <sup>3</sup> (2.75 cu. yd.)	2.3 m <sup>3</sup> (3.0 cu. yd.)	2.1 m <sup>3</sup> (2.75 cu. yd.)	2.1 m <sup>3</sup> (2.75 cu. yd.)
Capacity, Struck	1.7 m <sup>3</sup> (2.26 cu. yd.)	1.9 m <sup>3</sup> (2.53 cu. yd.)	1.7 m <sup>3</sup> (2.26 cu. yd.)	1.7 m <sup>3</sup> (2.26 cu. yd.)
Bucket Weight with Bolt-On Cutting Edge	1056 kg (2,327 lb.)	1095 kg (2,415 lb.)	1056 kg (2,327 lb.)	1056 kg (2,327 lb.)
Bucket Width	2.55 m (8 ft. 4 in.)	2.55 m (8 ft. 4 in.)	2.55 m (8 ft. 4 in.)	2.55 m (8 ft. 4 in.)
Breakout Force	11 070 kg (24,406 lb.)	10 285 kg (22,674 lb.)	10 952 kg (24,145 lb.)	11 059 kg (24,381 lb.)
Tipping Load, Straight, No Tire Deflection	10 297 kg (22,702 lb.)	10 172 kg (22,426 lb.)	8667 kg (19,107 lb.)	7967 kg (17,564 lb.)
Tipping Load, Straight, with Tire Deflection	9753 kg (21,502 lb.)	9630 kg (21,230 lb.)	8253 kg (18,195 lb.)	7614 kg (16,786 lb.)
Tipping Load, 40-deg. Full Turn, No Tire Deflection	8955 kg (19,742 lb.)	8840 kg (19,489 lb.)	7496 kg (16,526 lb.)	6860 kg (15,123 lb.)
Tipping Load, 40-deg. Full Turn, with Tire Deflection	8259 kg (18,208 lb.)	8145 kg (17,957 lb.)	6963 kg (15,351 lb.)	6390 kg (14,088 lb.)
Rated Operating Load, 50% Full-Turn Tipping Load, No Tire Deflection (conforms to ISO 14397-1)*	4477 kg (9,871 lb.)	4420 kg (9,745 lb.)	3748 kg (8,263 lb.)	3430 kg (7,562 lb.)
Rated Operating Load, 50% Full-Turn Tipping Load, with Tire Deflection (conforms to ISO 14397-1)*	4130 kg (9,104 lb.)	4073 kg (8,978 lb.)	3482 kg (7,675 lb.)	3195 kg (7,044 lb.)
Operating Weight	13 123 kg (28,931 lb.)	13 163 kg (29,018 lb.)	13 341 kg (29,412 lb.)	13 457 kg (29,667 lb.)

Loader operating information is based on machine with identified linkage and standard equipment, PowerTech PVS 6068 (EPA Final Tier 4/EU Stage V) engine, ROPS cab, rear cast bumper/counterweight, transmission side-frame guards, bottom guards, standard tires, full fuel tank, and 79-kg (175 lb.) operator. This information is affected by changes in tires, ballast, and different attachments.

\*Rated operating capacity based on Deere attachments only.

**Dimensions and Specifications with Hi-Vis Coupler and Hook-On Bucket** **524L Z-BAR / HIGH-LIFT / HIGH-LIFT PLUS / TOOL CARRIER**

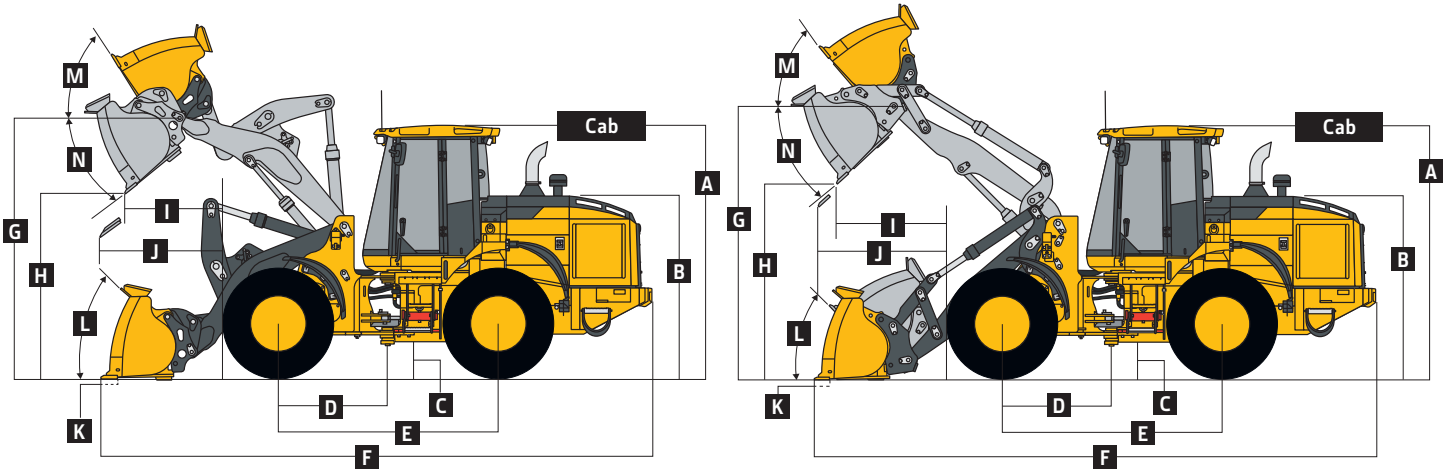

**524L Z-BAR / HIGH-LIFT / HIGH-LIFT PLUS LOADERS WITH HI-VIS COUPLER AND HOOK-ON BUCKET WITH BOLT-ON EDGE**

**524L TOOL-CARRIER LOADER WITH HI-VIS COUPLER AND HOOK-ON BUCKET WITH BOLT-ON EDGE**

	Z-Bar 2.1-m <sup>3</sup> (2.75 cu. yd.) general	Z-Bar 3.1-m <sup>3</sup> (4.0 cu. yd.) light material	High-Lift 2.1-m <sup>3</sup> (2.75 cu. yd.) general	High-Lift 3.1-m <sup>3</sup> (4.0 cu. yd.) light material	High-Lift Plus 1.9-m <sup>3</sup> (2.5 cu. yd.) general	High-Lift Plus 3.1-m <sup>3</sup> (4.0 cu. yd.) light material	Tool Carrier 2.1-m <sup>3</sup> (2.75 cu. yd.) general	Tool Carrier 3.1-m <sup>3</sup> (4.0 cu. yd.) light material
<b>Dimensions with Bucket with Bolt-On Edge</b>								
<b>A</b> Height to Top of Cab	3.33 m (10 ft. 11 in.)	3.33 m (10 ft. 11 in.)	3.33 m (10 ft. 11 in.)	3.33 m (10 ft. 11 in.)	3.33 m (10 ft. 11 in.)	3.33 m (10 ft. 11 in.)	3.33 m (10 ft. 11 in.)	3.33 m (10 ft. 11 in.)
<b>B</b> Hood Height	2.375 m (7 ft. 9 in.)	2.375 m (7 ft. 9 in.)	2.375 m (7 ft. 9 in.)	2.375 m (7 ft. 9 in.)	2.375 m (7 ft. 9 in.)	2.375 m (7 ft. 9 in.)	2.375 m (7 ft. 9 in.)	2.375 m (7 ft. 9 in.)
<b>C</b> Ground Clearance	0.40 m (15.7 in.)	0.40 m (15.7 in.)	0.40 m (15.7 in.)	0.40 m (15.7 in.)	0.40 m (15.7 in.)	0.40 m (15.7 in.)	0.40 m (15.7 in.)	0.40 m (15.7 in.)
<b>D</b> Length from Centerline to Front Axle	1.45 m (4 ft. 9 in.)	1.45 m (4 ft. 9 in.)	1.45 m (4 ft. 9 in.)	1.45 m (4 ft. 9 in.)	1.45 m (4 ft. 9 in.)	1.45 m (4 ft. 9 in.)	1.45 m (4 ft. 9 in.)	1.45 m (4 ft. 9 in.)
<b>E</b> Wheelbase	2.93 m (9 ft. 7 in.)	2.93 m (9 ft. 7 in.)	2.93 m (9 ft. 7 in.)	2.93 m (9 ft. 7 in.)	2.93 m (9 ft. 7 in.)	2.93 m (9 ft. 7 in.)	2.93 m (9 ft. 7 in.)	2.93 m (9 ft. 7 in.)
<b>F</b> Overall Length, Bucket on Ground	7.52 m (24 ft. 8 in.)	7.65 m (25 ft. 1 in.)	7.95 m (26 ft. 1 in.)	8.08 m (26 ft. 6 in.)	8.15 m (26 ft. 9 in.)	8.37 m (27 ft. 6 in.)	7.77 m (25 ft. 6 in.)	7.80 m (25 ft. 7 in.)
<b>G</b> Height to Hinge Pin, Fully Raised	3.81 m (12 ft. 6 in.)	3.81 m (12 ft. 6 in.)	4.17 m (13 ft. 8 in.)	4.17 m (13 ft. 8 in.)	4.42 m (14 ft. 6 in.)	4.42 m (14 ft. 6 in.)	3.89 m (12 ft. 9 in.)	3.89 m (12 ft. 9 in.)
<b>H</b> Dump Clearance, 45 deg., Full Height	2.68 m (8 ft. 10 in.)	2.60 m (8 ft. 6 in.)	3.04 m (10 ft. 0 in.)	2.96 m (9 ft. 9 in.)	3.35 m (11 ft. 0 in.)	3.21 m (10 ft. 6 in.)	2.79 m (9 ft. 2 in.)	2.70 m (8 ft. 10 in.)
<b>I</b> Reach, 45-deg. Dump, Full Height	1.09 m (3 ft. 7 in.)	1.19 m (3 ft. 11 in.)	1.19 m (3 ft. 11 in.)	1.29 m (4 ft. 3 in.)	1.17 m (3 ft. 10 in.)	1.33 m (4 ft. 4 in.)	1.34 m (4 ft. 5 in.)	1.44 m (4 ft. 9 in.)
<b>J</b> Reach, 45-deg. Dump, 2.13-m (7 ft. 0 in.) Clearance	1.50 m (4 ft. 11 in.)	1.55 m (5 ft. 1 in.)	1.87 m (6 ft. 2 in.)	1.92 m (6 ft. 4 in.)	2.06 m (6 ft. 9 in.)	2.16 m (7 ft. 1 in.)	1.81 m (5 ft. 11 in.)	1.86 m (6 ft. 1 in.)
<b>K</b> Maximum Digging Depth	108 mm (4.2 in.)	111 mm (4.4 in.)	199 mm (7.8 in.)	202 mm (8.0 in.)	196 mm (7.7 in.)	207 mm (8.1 in.)	100 mm (3.9 in.)	102 mm (4.0 in.)
<b>L</b> Maximum Rollback at Ground Level	44 deg.	44 deg.	48 deg.	48 deg.	49 deg.	49 deg.	50 deg.	50 deg.
<b>M</b> Maximum Rollback, Boom Fully Raised	60 deg.	60 deg.	60 deg.	60 deg.	61 deg.	61 deg.	55 deg.	55 deg.
<b>N</b> Maximum Bucket Dump Angle, Fully Raised	50 deg.	50 deg.	46 deg.	46 deg.	45 deg.	45 deg.	46 deg.	46 deg.
Loader Clearance Circle, Bucket Carry Position	11.44 m (37 ft. 7 in.)	11.80 m (38 ft. 9 in.)	11.78 m (38 ft. 8 in.)	12.22 m (40 ft. 1 in.)	12.02 m (39 ft. 6 in.)	12.54 m (41 ft. 2 in.)	11.24 m (36 ft. 11 in.)	12.04 m (39 ft. 6 in.)
<b>Specifications with Bucket with Bolt-On Edge</b>								
Capacity, Heaped	2.1 m <sup>3</sup> (2.75 cu. yd.)	3.1 m <sup>3</sup> (4.0 cu. yd.)	2.1 m <sup>3</sup> (2.75 cu. yd.)	3.1 m <sup>3</sup> (4.0 cu. yd.)	1.9 m <sup>3</sup> (2.5 cu. yd.)	3.1 m <sup>3</sup> (4.0 cu. yd.)	2.1 m <sup>3</sup> (2.75 cu. yd.)	3.1 m <sup>3</sup> (4.0 cu. yd.)
Capacity, Struck	1.7 m <sup>3</sup> (2.26 cu. yd.)	2.6 m <sup>3</sup> (3.4 cu. yd.)	1.7 m <sup>3</sup> (2.26 cu. yd.)	2.6 m <sup>3</sup> (3.4 cu. yd.)	1.5 m <sup>3</sup> (1.96 cu. yd.)	2.6 m <sup>3</sup> (3.4 cu. yd.)	1.7 m <sup>3</sup> (2.26 cu. yd.)	2.6 m <sup>3</sup> (3.4 cu. yd.)
Bucket Weight with Bolt-On Cutting Edge	1454 kg (3,205 lb.)	1683 kg (3,711 lb.)	1454 kg (3,205 lb.)	1683 kg (3,711 lb.)	1385 kg (3,052 lb.)	1683 kg (3,711 lb.)	1437 kg (3,167 lb.)	1656 kg (3,651 lb.)
Bucket Width	2.55 m (8 ft. 4 in.)	2.89 m (9 ft. 6 in.)	2.55 m (8 ft. 4 in.)	2.89 m (9 ft. 6 in.)	2.55 m (8 ft. 4 in.)	2.89 m (9 ft. 6 in.)	2.55 m (8 ft. 4 in.)	2.89 m (9 ft. 6 in.)
Breakout Force	9604 kg (21,173 lb.)	8569 kg (18,891 lb.)	9500 kg (20,945 lb.)	8475 kg (18,684 lb.)	10 383 kg (22,891 lb.)	8559 kg (18,870 lb.)	10 660 kg (23,501 lb.)	9109 kg (20,081 lb.)
Tipping Load, Straight, No Tire Deflection	9483 kg (20,906 lb.)	9168 kg (20,212 lb.)	7969 kg (17,568 lb.)	7672 kg (16,913 lb.)	7436 kg (16,394 lb.)	7032 kg (15,504 lb.)	8691 kg (19,160 lb.)	8385 kg (18,486 lb.)
Tipping Load, Straight, with Tire Deflection	8967 kg (19,769 lb.)	8637 kg (19,041 lb.)	7575 kg (16,700 lb.)	7260 kg (16,006 lb.)	7092 kg (15,635 lb.)	6672 kg (14,709 lb.)	8259 kg (18,208 lb.)	7938 kg (17,500 lb.)



**Dimensions and Specifications with Hi-Vis Coupler and Hook-On Bucket (continued)**

**524L Z-BAR / HIGH-LIFT / HIGH-LIFT PLUS / TOOL CARRIER**

	Z-Bar 2.1-m <sup>3</sup> (2.75 cu. yd.)	Z-Bar 3.1-m <sup>3</sup> (4.0 cu. yd.)	High-Lift 2.1-m <sup>3</sup> (2.75 cu. yd.)	High-Lift 3.1-m <sup>3</sup> (4.0 cu. yd.)	High-Lift Plus 1.9-m <sup>3</sup> (2.5 cu. yd.)	High-Lift Plus 3.1-m <sup>3</sup> (4.0 cu. yd.)	Tool Carrier 2.1-m <sup>3</sup> (2.75 cu. yd.)	Tool Carrier 3.1-m <sup>3</sup> (4.0 cu. yd.)
<b>Specifications with Bucket with Bolt-On Edge (continued)</b>	general purpose	light material	general purpose	light material	general purpose	light material	general purpose	light material
Tipping Load, 40-deg. Full Turn, No Tire Deflection	8199 kg (18,075 lb.)	7888 kg (17,391 lb.)	6841 kg (15,082 lb.)	6548 kg (14,436 lb.)	6360 kg (14,021 lb.)	5965 kg (13,150 lb.)	7503 kg (16,541 lb.)	7203 kg (15,880 lb.)
Tipping Load, 40-deg. Full Turn, with Tire Deflection	7539 kg (16,621 lb.)	7206 kg (15,886 lb.)	6327 kg (13,949 lb.)	6033 kg (13,300 lb.)	5919 kg (13,049 lb.)	5493 kg (12,110 lb.)	6936 kg (15,291 lb.)	6633 kg (14,623 lb.)
Rated Operating Load, 50% Full-Turn Tipping Load, No Tire Deflection (conforms to ISO 14397-1)*	4099 kg (9,037 lb.)	3944 kg (8,695 lb.)	3421 kg (7,541 lb.)	3274 kg (7,218 lb.)	3180 kg (7,011 lb.)	2982 kg (6,575 lb.)	3752 kg (8,271 lb.)	3602 kg (7,940 lb.)
Rated Operating Load, 50% Full-Turn Tipping Load, with Tire Deflection (conforms to ISO 14397-1)*	3770 kg (8,310 lb.)	3603 kg (7,943 lb.)	3164 kg (6,974 lb.)	3017 kg (6,650 lb.)	2960 kg (6,525 lb.)	2747 kg (6,055 lb.)	3468 kg (7,646 lb.)	3317 kg (7,312 lb.)
Operating Weight	13 541 kg (29,853 lb.)	13 770 kg (30,359 lb.)	13 760 kg (30,335 lb.)	13 989 kg (30,841 lb.)	13 806 kg (30,438 lb.)	14 105 kg (31,097 lb.)	13 390 kg (29,520 lb.)	13 610 kg (30,004 lb.)

Loader operating information is based on machine with identified linkage and standard equipment, PowerTech PVS 6068 (EPA Final Tier 4/EU Stage V) engine, ROPS cab, rear cast bumper/counterweight, transmission side-frame guards, bottom guards, standard tires, full fuel tank, and 79-kg (175 lb.) operator. This information is affected by changes in tires, ballast, and different attachments.

\*Rated operating capacity based on Deere attachments only.

**Dimensions and Specifications with Hi-Vis Coupler and Hook-On Construction Forks**

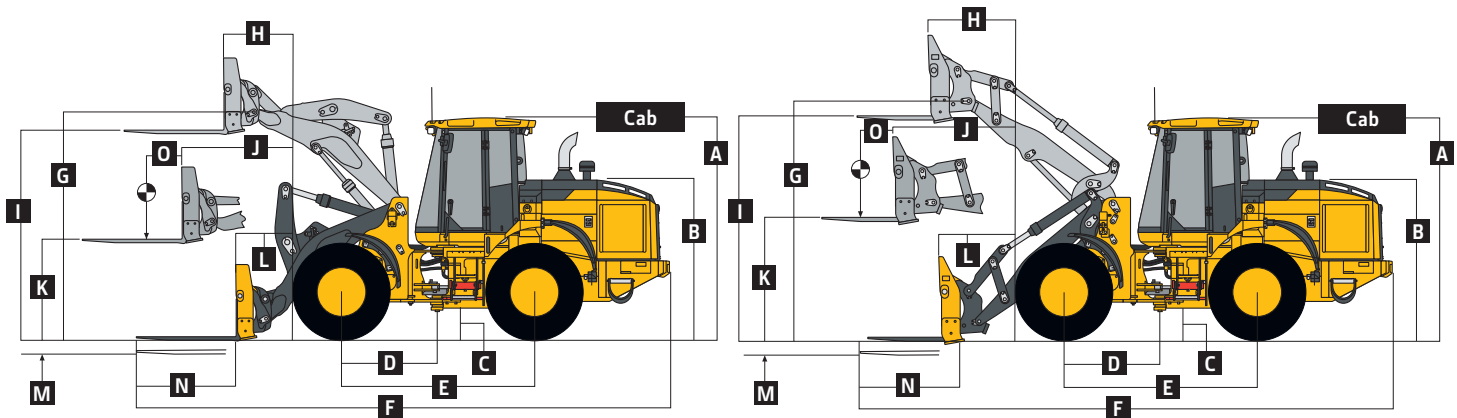

**524L Z-BAR / HIGH-LIFT / HIGH-LIFT PLUS LOADERS WITH HI-VIS COUPLER AND HOOK-ON CONSTRUCTION FORKS**

**524L TOOL-CARRIER LOADER WITH HI-VIS COUPLER AND HOOK-ON CONSTRUCTION FORKS**

	Z-Bar 1.22-m (48 in.) tine length	Z-Bar 1.52-m (60 in.) tine length	High-Lift 1.22-m (48 in.) tine length	High-Lift 1.52-m (60 in.) tine length	High-Lift Plus 1.22-m (48 in.) tine length	High-Lift Plus 1.52-m (60 in.) tine length	Tool Carrier 1.22-m (48 in.) tine length	Tool Carrier 1.52-m (60 in.) tine length
<b>Dimensions with Forks</b>								
<b>A</b> Height to Top of Cab	3.33 m (10 ft. 11 in.)	3.33 m (10 ft. 11 in.)	3.33 m (10 ft. 11 in.)	3.33 m (10 ft. 11 in.)	3.33 m (10 ft. 11 in.)	3.33 m (10 ft. 11 in.)	3.33 m (10 ft. 11 in.)	3.33 m (10 ft. 11 in.)
<b>B</b> Hood Height	2.375 m (7 ft. 9 in.)	2.375 m (7 ft. 9 in.)	2.375 m (7 ft. 9 in.)	2.375 m (7 ft. 9 in.)	2.375 m (7 ft. 9 in.)	2.375 m (7 ft. 9 in.)	2.375 m (7 ft. 9 in.)	2.375 m (7 ft. 9 in.)
<b>C</b> Ground Clearance	0.40 m (15.7 in.)	0.40 m (15.7 in.)	0.40 m (15.7 in.)	0.40 m (15.7 in.)	0.40 m (15.7 in.)	0.40 m (15.7 in.)	0.40 m (15.7 in.)	0.40 m (15.7 in.)
<b>D</b> Length from Centerline to Front Axle	1.45 m (4 ft. 9 in.)	1.45 m (4 ft. 9 in.)	1.45 m (4 ft. 9 in.)	1.45 m (4 ft. 9 in.)	1.45 m (4 ft. 9 in.)	1.45 m (4 ft. 9 in.)	1.45 m (4 ft. 9 in.)	1.45 m (4 ft. 9 in.)
<b>E</b> Wheelbase	2.93 m (9 ft. 7 in.)	2.93 m (9 ft. 7 in.)	2.93 m (9 ft. 7 in.)	2.93 m (9 ft. 7 in.)	2.93 m (9 ft. 7 in.)	2.93 m (9 ft. 7 in.)	2.93 m (9 ft. 7 in.)	2.93 m (9 ft. 7 in.)
<b>F</b> Overall Length, Forks on Ground	7.94 m (26 ft. 1 in.)	8.24 m (27 ft. 1 in.)	8.37 m (27 ft. 6 in.)	8.68 m (28 ft. 6 in.)	8.67 m (28 ft. 5 in.)	8.97 m (29 ft. 5 in.)	8.13 m (26 ft. 8 in.)	8.44 m (27 ft. 8 in.)
<b>G</b> Height to Hinge Pin, Fully Raised	3.81 m (12 ft. 6 in.)	3.81 m (12 ft. 6 in.)	4.17 m (13 ft. 8 in.)	4.17 m (13 ft. 8 in.)	4.42 m (14 ft. 6 in.)	4.42 m (14 ft. 6 in.)	3.89 m (12 ft. 9 in.)	3.89 m (12 ft. 9 in.)
<b>H</b> Reach, Fully Raised	0.82 m (32 in.)	0.82 m (32 in.)	0.92 m (3 ft. 0 in.)	0.92 m (3 ft. 0 in.)	0.96 m (3 ft. 2 in.)	0.96 m (3 ft. 2 in.)	1.08 m (3 ft. 7 in.)	1.08 m (3 ft. 7 in.)
<b>I</b> Fork Height, Fully Raised	3.48 m (11 ft. 5 in.)	3.48 m (11 ft. 5 in.)	3.84 m (12 ft. 7 in.)	3.84 m (12 ft. 7 in.)	4.09 m (13 ft. 5 in.)	4.09 m (13 ft. 5 in.)	3.66 m (12 ft. 0 in.)	3.66 m (12 ft. 0 in.)
<b>J</b> Maximum Reach, Fork Level	1.56 m (5 ft. 1 in.)	1.56 m (5 ft. 1 in.)	1.89 m (6 ft. 2 in.)	1.89 m (6 ft. 2 in.)	2.10 m (6 ft. 11 in.)	2.10 m (6 ft. 11 in.)	1.81 m (5 ft. 11 in.)	1.81 m (5 ft. 11 in.)
<b>K</b> Fork Height, Maximum Reach	1.65 m (5 ft. 5 in.)	1.65 m (5 ft. 5 in.)	1.66 m (5 ft. 5 in.)	1.66 m (5 ft. 5 in.)	1.66 m (5 ft. 5 in.)	1.66 m (5 ft. 5 in.)	1.83 m (6 ft. 0 in.)	1.83 m (6 ft. 0 in.)
<b>L</b> Reach, Ground Level	0.99 m (3 ft. 3 in.)	0.99 m (3 ft. 3 in.)	1.40 m (4 ft. 7 in.)	1.40 m (4 ft. 7 in.)	1.65 m (5 ft. 5 in.)	1.65 m (5 ft. 5 in.)	1.17 m (3 ft. 10 in.)	1.17 m (3 ft. 10 in.)
<b>M</b> Depth Below Ground	99 mm (4 in.)	99 mm (4 in.)	189 mm (7 in.)	189 mm (7 in.)	195 mm (8 in.)	195 mm (8 in.)	154 mm (6 in.)	154 mm (6 in.)
<b>N</b> Tine Length	1.22 m (48 in.)	1.52 m (60 in.)	1.22 m (48 in.)	1.52 m (60 in.)	1.22 m (48 in.)	1.52 m (60 in.)	1.22 m (48 in.)	1.52 m (60 in.)
<b>O</b> Load Position, 50% Tine Length	0.61 m (24 in.)	0.76 m (30 in.)	0.61 m (24 in.)	0.76 m (30 in.)	0.61 m (24 in.)	0.76 m (30 in.)	0.61 m (24 in.)	0.76 m (30 in.)

## Dimensions and Specifications with Hi-Vis Coupler and Hook-On

### Construction Forks (continued)

### 524L Z-BAR / HIGH-LIFT / HIGH-LIFT PLUS / TOOL CARRIER

	Z-Bar 1.22-m (48 in.) tine length	Z-Bar 1.52-m (60 in.) tine length	High-Lift 1.22-m (48 in.) tine length	High-Lift 1.52-m (60 in.) tine length	High-Lift Plus 1.22-m (48 in.) tine length	High-Lift Plus 1.52-m (60 in.) tine length	Tool Carrier 1.22-m (48 in.) tine length	Tool Carrier 1.52-m (60 in.) tine length
<b>Specifications with Forks</b>								
Tipping Load, Straight, No Tire Deflection	6990 kg (15,411 lb.)	6574 kg (14,494 lb.)	6101 kg (13,451 lb.)	5760 kg (12,698 lb.)	5701 kg (12,569 lb.)	5393 kg (11,889 lb.)	6504 kg (14,339 lb.)	6135 kg (13,525 lb.)
Tipping Load, Straight, with Tire Deflection	6801 kg (14,994 lb.)	6393 kg (14,094 lb.)	5943 kg (13,102 lb.)	5616 kg (12,381 lb.)	5538 kg (12,209 lb.)	5250 kg (11,574 lb.)	6333 kg (13,962 lb.)	5976 kg (13,175 lb.)
Tipping Load, 40-deg. Full Turn, No Tire Deflection	6050 kg (13,338 lb.)	5681 kg (12,524 lb.)	5246 kg (11,566 lb.)	4943 kg (10,898 lb.)	4877 kg (10,752 lb.)	4604 kg (10,149 lb.)	5619 kg (12,388 lb.)	5289 kg (11,660 lb.)
Tipping Load, 40-deg. Full Turn, with Tire Deflection	5796 kg (12,778 lb.)	5442 kg (11,998 lb.)	5013 kg (11,052 lb.)	4728 kg (10,423 lb.)	4674 kg (10,304 lb.)	4401 kg (9,703 lb.)	5385 kg (11,872 lb.)	5085 kg (11,210 lb.)
Rated Operating Load, 50% Full-Turn Tipping Load, with Tire Deflection (conforms to ISO 14397-1 and SAE J1197)*	2898 kg (6,389 lb.)	2721 kg (5,999 lb.)	2507 kg (5,526 lb.)	2364 kg (5,212 lb.)	2337 kg (5,152 lb.)	2201 kg (4,851 lb.)	2693 kg (5,936 lb.)	2543 kg (5,605 lb.)
Rated Operating Load, Rough Terrain, 60% Full-Turn Tipping Load, with Tire Deflection (conforms to EN474-3)*	3478 kg (7,667 lb.)	3265 kg (7,199 lb.)	3008 kg (6,631 lb.)	2837 kg (6,254 lb.)	2804 kg (6,183 lb.)	2641 kg (5,822 lb.)	3231 kg (7,123 lb.)	3051 kg (6,726 lb.)
Rated Operating Load, Firm and Level Ground, 80% Full-Turn Tipping Load, with Tire Deflection (conforms to EN474-3)*	4637 kg (10,222 lb.)	4354 kg (9,598 lb.)	4010 kg (8,841 lb.)	3782 kg (8,339 lb.)	3739 kg (8,244 lb.)	3521 kg (7,762 lb.)	4308 kg (9,498 lb.)	4068 kg (8,968 lb.)
Operating Weight	13 366 kg (29,468 lb.)	13 427 kg (29,601 lb.)	13 585 kg (29,950 lb.)	13 646 kg (30,084 lb.)	13 701 kg (30,206 lb.)	13 762 kg (30,339 lb.)	13 206 kg (29,114 lb.)	13 266 kg (29,246 lb.)

Loader operating information is based on machine with identified linkage and standard equipment, PowerTech PVS 6068 (EPA Final Tier 4/EU Stage V) engine, ROPS cab, rear cast bumper/counterweight, transmission side-frame guards, bottom guards, standard tires, full fuel tank, and 79-kg (175 lb.) operator. This information is affected by changes in tires, ballast, and different attachments.

\*Rated operating capacity based on Deere attachments only.

### Adjustments to Operating Weights and Tipping Loads with Buckets

Adjustments to operating weights, tipping loads, and tires are based on Z-Bar machine with pin-on 2.1-m<sup>3</sup> (2.75 cu. yd.) general-purpose bucket with bolt-on cutting edge, ROPS cab, rear cast bumper/counterweight, transmission side-frame guards, bottom guards, standard tires, full fuel tank, and 79-kg (175 lb.) operator\*

Add (+) or deduct (-) kg (lb.) as indicated for loaders with 3-piece rims	Tipping Load,		Tipping Load,			
	Operating Weight	Straight	40-deg. Full Turn	Tread Width	Width Over Tires	Vertical Height
Michelin 20.5 R 25, 1 Star L-3 XHA2	0 kg (0 lb.)	0 kg (0 lb.)	0 kg (0 lb.)	0 mm (0 in.)	0 mm (0 in.)	0 mm (0 in.)
Bridgestone 20.5 R 25, 1 Star L-3 VJT	+4 kg (+9 lb.)	+3 kg (+6 lb.)	+3 kg (+6 lb.)	0 mm (0 in.)	+2 mm (+0.1 in.)	-41 mm (-1.6 in.)
Titan 20.5 R 25, 1 Star L-3 STL3	+11 kg (+23 lb.)	+8 kg (+17 lb.)	+7 kg (+15 lb.)	0 mm (0 in.)	-7 mm (-0.3 in.)	-5 mm (-0.2 in.)
Michelin 20.5 R 25, 1 Star L-2 XTLA	-152 kg (-335 lb.)	-109 kg (-241 lb.)	-96 kg (-212 lb.)	0 mm (0 in.)	+4 mm (+0.2 in.)	-11 mm (-0.4 in.)
Bridgestone 20.5 R 25, 1 Star L-2 VUT	-65 kg (-144 lb.)	-47 kg (-104 lb.)	-41 kg (-91 lb.)	0 mm (0 in.)	+3 mm (+0.1 in.)	-10 mm (-0.4 in.)
Titan 20.5 R 25, 1 Star L-2 TGD2	-85 kg (-188 lb.)	-61 kg (-135 lb.)	-54 kg (-119 lb.)	0 mm (0 in.)	-7 mm (-0.3 in.)	-10 mm (-0.4 in.)
Titan 20.5-25, 16 PR L-2	-245 kg (-541 lb.)	-176 kg (-389 lb.)	-155 kg (-343 lb.)	0 mm (0 in.)	+8 mm (+0.3 in.)	-2 mm (-0.1 in.)
Firestone 20.5-25, 16 PR L-2 SGG LD	-280 kg (-617 lb.)	-201 kg (-443 lb.)	-177 kg (-391 lb.)	0 mm (0 in.)	+5 mm (+0.2 in.)	-1 mm (0 in.)
Titan 20.5-25, 12 PR L-2	-266 kg (-587 lb.)	-191 kg (-422 lb.)	-169 kg (-372 lb.)	0 mm (0 in.)	+8 mm (+0.3 in.)	-2 mm (-0.1 in.)
Firestone 20.5-25, 16 PR L-3 SRG LD	-276 kg (-608 lb.)	-198 kg (-437 lb.)	-175 kg (-385 lb.)	0 mm (0 in.)	+8 mm (+0.3 in.)	+3 mm (+0.1 in.)
Michelin 20.5 R 25, 1 Star L2 SNO-PLUS	-96 kg (-212 lb.)	-69 kg (-152 lb.)	-61 kg (-134 lb.)	0 mm (0 in.)	+6 mm (+0.2 in.)	-16 mm (-0.6 in.)
Michelin 620/75R26 MegaXbib <sup>®</sup>	-189 kg (-417 lb.)	-136 kg (-300 lb.)	-120 kg (-264 lb.)	+187 mm (+7.4 in.)	+247 mm (+9.7 in.)	+23 mm (+0.9 in.)
CaCl <sub>2</sub> in 20.5-25, L-3 Rear Tires, 75% Fill	+825 kg (+1,820 lb.)	+1185 kg (+2,613 lb.)	+1045 kg (+2,304 lb.)	N/A	N/A	N/A

\*May change based on vehicle configuration, weight, or tire-pressure adjustments.

<sup>®</sup>Equipped with 1-piece rims.

<sup>®</sup>Requires 8-deg. rear axle stops.

**Bucket Selection Guides 524L Z-BAR / HIGH-LIFT / HIGH-LIFT PLUS / TOOL CARRIER**

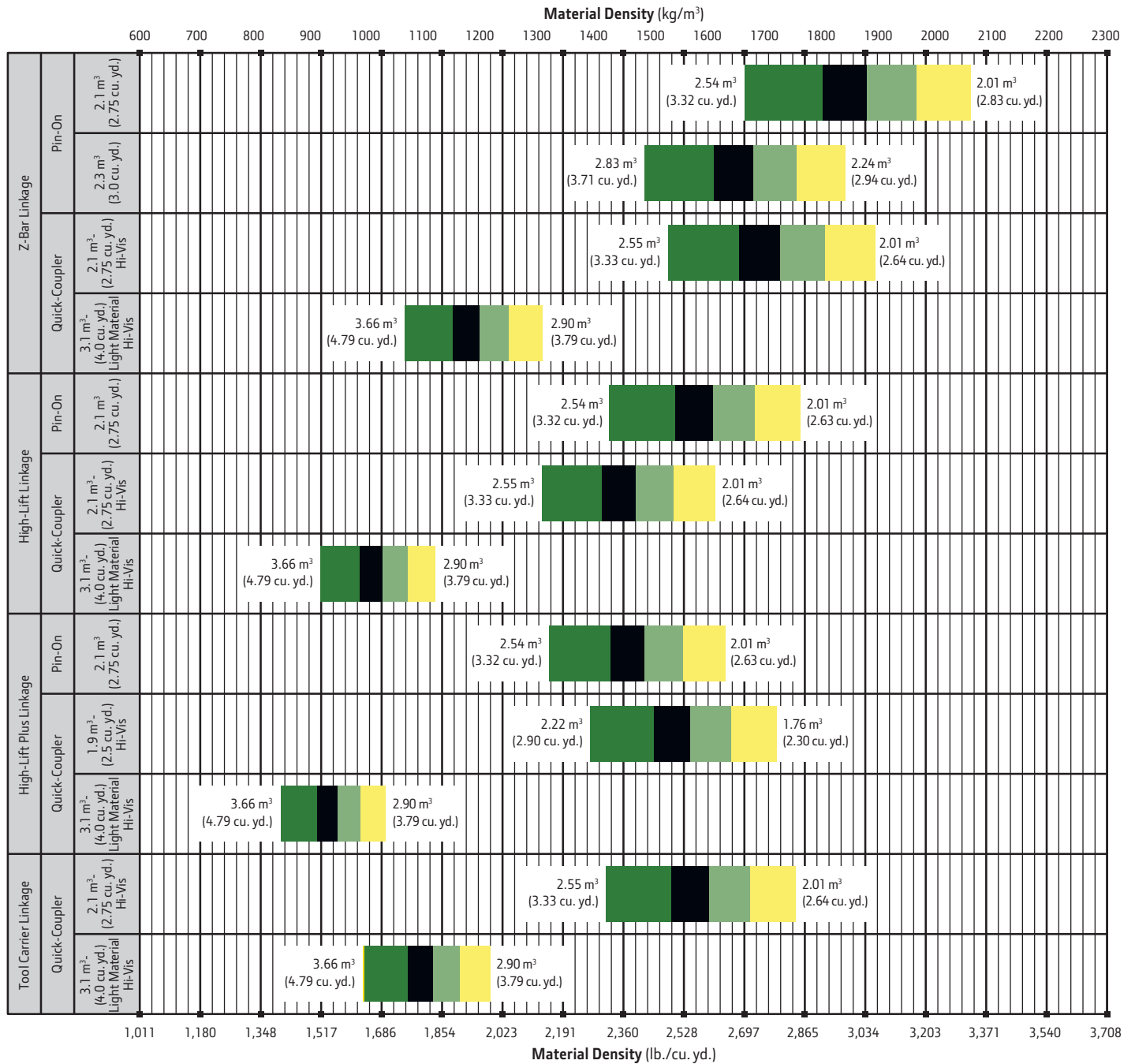

LOOSE MATERIALS		kg/m³	lb./cu. yd.	LOOSE MATERIALS		kg/m³	lb./cu. yd.
Chips, pulpwood	288	486	Limestone, coarse, sized	1570	2,646		
Cinders (coal, ashes, clinkers)	673	1,134	Limestone, mixed sizes	1682	2,835		
Clay and gravel, dry	1602	2,700	Limestone, pulverized or crushed	1362	2,295		
Clay, compact, solid	1746	2,943	Sand, damp	2083	3,510		
Clay, dry in lump loose	1009	1,701	Sand, dry	1762	2,970		
Clay, excavated in water	1282	2,160	Sand, voids, full of water	2083	3,510		
Coal, anthracite, broken, loose	865	1,458	Sandstone, quarried	1314	2,214		
Coal, bituminous, moderately wet	801	1,350	Shale, broken crushed	1362	2,295		
Earth, common loam, dry	1218	2,052	Slag, furnace granulated	1955	3,294		
Earth, mud, packed	1843	3,105	Stone or gravel, 37.5 to 87.5-mm (1.5 to 3.5 in.) size	1442	2,430		
Granite, broken	1538	2,592	Stone or gravel, 18.75-mm (0.75 in.) size	1602	2,700		
Gypsum	2275	3,834					

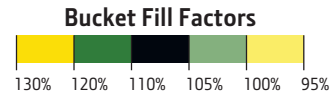



# 544L SPECIFICATIONS

While general information, pictures, and descriptions are provided, some illustrations and text may include product options and accessories NOT AVAILABLE in all regions, and in some countries products and accessories may require modifications or additions to ensure compliance with the local regulations of those countries.

<b>Engine</b>		<b>544L Z-BAR / HIGH-LIFT / HIGH-LIFT PLUS</b>		
Manufacturer and Model	John Deere PowerTech™ PVS 6068	Gross Peak Torque (ISO 9249)	770 Nm (568 ft.-lb.) at 1,600 rpm	
Non-Road Emission Standard	EPA Final Tier 4/EU Stage V	Net Torque Rise	47%	
Cylinders	6	Fuel System (electronically controlled)	High-pressure common rail	
Valves Per Cylinder	4	Lubrication	Full-flow spin-on filter and integral cooler	
Displacement	6.8 L (414 cu. in.)	Aspiration	Turbocharged, charge air cooled	
Net Peak Power (ISO 9249)	123 kW (166 hp) at 1,700 rpm	Air Cleaner	Under-hood, dual-element dry type, restriction indicator in cab monitor for service	
Gross Peak Power (ISO 9249)	130 kW (174 hp) at 1,700 rpm			
Net Peak Torque (ISO 9249)	740 Nm (546 lb.-ft.) at 1,100 rpm			
<b>Cooling</b>				
Fan Drive	Hydraulically driven, proportionally controlled, fan aft of coolers			
<b>Electrical</b>				
Electrical System	24 volt with 100-amp alternator (optional 130-amp alternator)			
Batteries (2 – 12 volt)	950 CCA (each)			
<b>Transmission System</b>				
Type	Countershaft-type PowerShift™			
Torque Converter	Single stage, single phase			
Shift Control	Electronically modulated, adaptive, load and speed dependent			
Operator Interface	Steering-column or joystick-mounted F-N-R and gear-select lever; kick-down button on hydraulic lever			
Shift Modes	Manual/auto (1st-D or 2nd-D); Quick-Shift button with 2 selectable modes: kick-down or kick-up/down; and 4 clutch cutoff settings			
	<i>Standard 5-Speed with Lockup Torque Converter</i>		<i>Optional 5-Speed without Lockup Torque Converter</i>	
Maximum Travel Speeds (with 20.5 R 25 tires)	<i>Forward</i>	<i>Reverse</i>	<i>Forward</i>	<i>Reverse</i>
Range 1	6.1 km/h (3.7 mph)	5.9 km/h (3.6 mph)	5.6 km/h (3.5 mph)	6.0 km/h (3.7 mph)
Range 2	12.0 km/h (7.4 mph)	12.7 km/h (7.8 mph)	11.2 km/h (7.0 mph)	11.9 km/h (7.3 mph)
Range 3	18.6 km/h (11.5 mph)	29.4 km/h (18.3 mph)	17.4 km/h (10.8 mph)	27.6 km/h (17.1 mph)
Range 4	27.9 km/h (17.3 mph)	N/A	26.2 km/h (16.2 mph)	N/A
Range 5	40.0 km/h (24.8 mph)	N/A	40.0 km/h (24.8 mph)	N/A
<b>Axles/Brakes</b>				
Final Drives	Heavy-duty inboard-mounted planetary			
Differentials	Hydraulic locking front with conventional rear — standard; dual locking front and rear — optional			
Rear Axle Oscillation, Stop to Stop (with 20.5 R 25 tires)	24 deg. (12 deg. each direction)			
Brakes (conform to ISO 3450)				
Service	Hydraulically actuated, spring-retracted, self-adjusting inboard sun-shaft mounted, oil cooled, single disc			
Parking	Automatic spring applied, hydraulically released, driveline mounted, sealed wet multi disc			
<b>Tires/Wheels (see page 24 for complete tire adjustments)</b>				
	<i>Tread Width</i>	<i>Width Over Tires</i>		
Michelin 20.5 R 25, 1 Star L-3 XHA2	1950 mm (76.8 in.)	2546 mm (100.2 in.)		
<b>Serviceability</b>				
<b>Refill Capacities</b>				
Fuel Tank (with lockable cap)	298 L (79 gal.)	Axle Oil (each)		
Cooling System	29.9 L (31.6 qt.)	Front	16.6 L (17.5 qt.)	
Diesel Exhaust Fluid (DEF)	15.6 L (16.5 qt.)	Rear	18 L (19 qt.)	
Engine Oil with Vertical Spin-On Filter	19.5 L (20.6 qt.)	Hydraulic Reservoir and Filter	82.1 L (21.7 gal.)	
Transmission Reservoir with Vertical Filter	21 L (22.2 qt.)	Park Brake Oil (wet disc)	0.3 L (10 oz.)	
<b>Hydraulic System/Steering</b>				
Pump (loader and steering)	Variable-displacement, axial-piston pump; closed-center, pressure-compensating system			
Maximum Rated Flow at 6895 kPa (1,000 psi) and 2,200 rpm	220 L/m (58 gpm)			
System Relief Pressure (loader and steering)	25 166 kPa (3,650 psi)			
Loader Controls	2-function valve, joystick control or fingertip controls, hydraulic-function enable/disable, optional 3rd- and 4th-function valve with auxiliary lever			
Steering (conforms to ISO 5010)	Steering-column-mounted, twist-grip shift lever; Quick-Shift button on hydraulic lever			
Type	Power, fully hydraulic			
Articulation Angle	80-deg. arc (40 deg. each direction)			
Turning Radius (measured to centerline of outside tire)	5.0 m (16 ft. 5 in.)			
Hydraulic Cycle Times	<i>Z-Bar / High-Lift / High-Lift Plus</i>			
Raise	5.5 sec.			
Dump	2.2 sec.			
Lower (power down)	3.5 sec.			
Total	11.2 sec.			

# 544L SPECIFICATIONS



While general information, pictures, and descriptions are provided, some illustrations and text may include product options and accessories NOT AVAILABLE in all regions, and in some countries products and accessories may require modifications or additions to ensure compliance with the local regulations of those countries.

## Dimensions and Specifications with Pin-On Bucket

### 544L Z-BAR / HIGH-LIFT / HIGH-LIFT PLUS

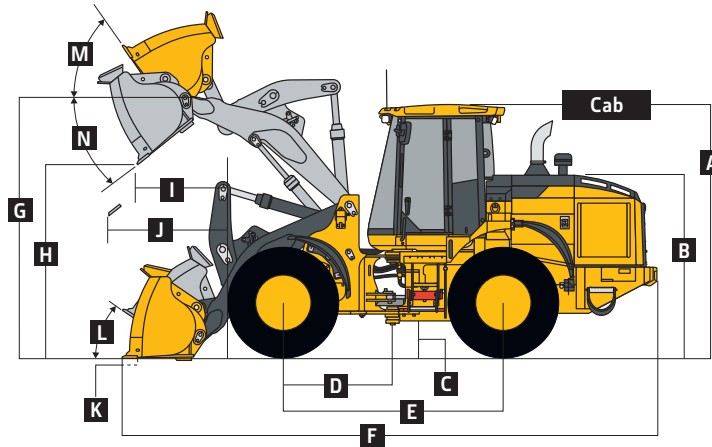

### 544L Z-BAR / HIGH-LIFT / HIGH-LIFT PLUS LOADERS WITH PIN-ON BUCKET WITH BOLT-ON EDGE

	Z-Bar 2.3-m <sup>3</sup> (3.0 cu. yd.) general purpose	Z-Bar 2.5-m <sup>3</sup> (3.25 cu. yd.) general purpose	High-Lift 2.1-m <sup>3</sup> (2.75 cu. yd.) general purpose	High-Lift 2.3-m <sup>3</sup> (3.0 cu. yd.) general purpose	High-Lift Plus 2.1-m <sup>3</sup> (2.75 cu. yd.) general purpose	High-Lift Plus 2.3-m <sup>3</sup> (3.0 cu. yd.) general purpose
<b>A</b> Height to Top of Cab	3.33 m (10 ft. 11 in.)	3.33 m (10 ft. 11 in.)	3.33 m (10 ft. 11 in.)	3.33 m (10 ft. 11 in.)	3.33 m (10 ft. 11 in.)	3.33 m (10 ft. 11 in.)
<b>B</b> Hood Height	2.375 m (7 ft. 9 in.)	2.375 m (7 ft. 9 in.)	2.375 m (7 ft. 9 in.)	2.375 m (7 ft. 9 in.)	2.375 m (7 ft. 9 in.)	2.375 m (7 ft. 9 in.)
<b>C</b> Ground Clearance	0.40 m (15.7 in.)	0.40 m (15.7 in.)	0.40 m (15.7 in.)	0.40 m (15.7 in.)	0.40 m (15.7 in.)	0.40 m (15.7 in.)
<b>D</b> Length from Centerline to Front Axle	1.45 m (4 ft. 9 in.)	1.45 m (4 ft. 9 in.)	1.45 m (4 ft. 9 in.)	1.45 m (4 ft. 9 in.)	1.45 m (4 ft. 9 in.)	1.45 m (4 ft. 9 in.)
<b>E</b> Wheelbase	2.93 m (9 ft. 7 in.)	2.93 m (9 ft. 7 in.)	2.93 m (9 ft. 7 in.)	2.93 m (9 ft. 7 in.)	2.93 m (9 ft. 7 in.)	2.93 m (9 ft. 7 in.)
<b>F</b> Overall Length, Bucket on Ground	7.49 m (24 ft. 7 in.)	7.49 m (24 ft. 7 in.)	7.80 m (25 ft. 7 in.)	7.88 m (25 ft. 10 in.)	8.17 m (26 ft. 10 in.)	8.25 m (27 ft. 1 in.)
<b>G</b> Height to Hinge Pin, Fully Raised	3.89 m (12 ft. 9 in.)	3.89 m (12 ft. 9 in.)	4.17 m (13 ft. 8 in.)	4.17 m (13 ft. 8 in.)	4.49 m (14 ft. 9 in.)	4.49 m (14 ft. 9 in.)
<b>H</b> Dump Clearance, 45 deg., Full Height	2.80 m (9 ft. 2 in.)	2.80 m (9 ft. 2 in.)	3.14 m (10 ft. 4 in.)	3.09 m (10 ft. 2 in.)	3.47 m (11 ft. 4 in.)	3.41 m (11 ft. 2 in.)
<b>I</b> Reach, 45-deg. Dump, Full Height	1.01 m (3 ft. 4 in.)	1.01 m (3 ft. 4 in.)	1.09 m (3 ft. 7 in.)	1.14 m (3 ft. 9 in.)	1.13 m (3 ft. 8 in.)	1.19 m (3 ft. 11 in.)
<b>J</b> Reach, 45-deg. Dump, 2.13-m (7 ft. 0 in.) Clearance	1.51 m (4 ft. 11 in.)	1.51 m (4 ft. 11 in.)	1.81 m (5 ft. 11 in.)	1.84 m (6 ft. 0 in.)	2.10 m (6 ft. 11 in.)	2.14 m (7 ft. 0 in.)
<b>K</b> Maximum Digging Depth	0.1 m (4 in.)	0.1 m (4 in.)	0.19 m (8 in.)	0.2 m (8 in.)	0.2 m (8 in.)	0.2 m (8 in.)
<b>L</b> Maximum Rollback at Ground Level	44 deg.	44 deg.	48 deg.	48 deg.	49 deg.	49 deg.
<b>M</b> Maximum Rollback, Boom Fully Raised	60 deg.	60 deg.	60 deg.	60 deg.	61 deg.	61 deg.
<b>N</b> Maximum Bucket Dump Angle, Fully Raised	48 deg.	48 deg.	46 deg.	46 deg.	45 deg.	45 deg.
Loader Clearance Circle, Bucket Carry Position	11.46 m (37 ft. 7 in.)	11.58 m (38 ft. 0 in.)	11.68 m (38 ft. 4 in.)	11.7 m (38 ft. 5 in.)	12.16 m (39 ft. 11 in.)	12.20 m (40 ft. 0 in.)
<b>Specifications with Bucket with Bolt-On Edge</b>						
Capacity, Heaped	2.3 m <sup>3</sup> (3.0 cu. yd.)	2.5 m <sup>3</sup> (3.25 cu. yd.)	2.1 m <sup>3</sup> (2.75 cu. yd.)	2.3 m <sup>3</sup> (3.0 cu. yd.)	2.1 m <sup>3</sup> (2.75 cu. yd.)	2.3 m <sup>3</sup> (3.0 cu. yd.)
Capacity, Struck	1.9 m <sup>3</sup> (2.5 cu. yd.)	2.1 m <sup>3</sup> (2.7 cu. yd.)	1.7 m <sup>3</sup> (2.3 cu. yd.)	1.9 m <sup>3</sup> (2.5 cu. yd.)	1.7 m <sup>3</sup> (2.3 cu. yd.)	1.9 m <sup>3</sup> (2.5 cu. yd.)
Bucket Weight with Bolt-On Cutting Edge	1095 kg (2,415 lb.)	1131 kg (2,493 lb.)	1056 kg (2,327 lb.)	1095 kg (2,415 lb.)	1056 kg (2,327 lb.)	1095 kg (2,415 lb.)
Bucket Width	2.54 m (8 ft. 4 in.)	2.68 m (8 ft. 10 in.)	2.55 m (8 ft. 4 in.)	2.54 m (8 ft. 4 in.)	2.55 m (8 ft. 4 in.)	2.54 m (8 ft. 4 in.)
Breakout Force	13 166 kg (29,026 lb.)	13 145 kg (28,979 lb.)	13 983 kg (30,827 lb.)	13 005 kg (28,672 lb.)	14 138 kg (31,168 lb.)	13 149 kg (28,988 lb.)
Tipping Load, Straight, No Tire Deflection	11 139 kg (24,557 lb.)	11 097 kg (24,464 lb.)	9699 kg (21,384 lb.)	9591 kg (21,145 lb.)	8630 kg (19,026 lb.)	8537 kg (18,820 lb.)
Tipping Load, Straight, with Tire Deflection	10 533 kg (23,221 lb.)	10 491 kg (23,129 lb.)	9231 kg (20,351 lb.)	9120 kg (20,106 lb.)	8244 kg (18,175 lb.)	8145 kg (17,957 lb.)
Tipping Load, 40-deg. Full Turn, No Tire Deflection	9653 kg (21,281 lb.)	9612 kg (21,190 lb.)	8374 kg (18,460 lb.)	8274 kg (18,241 lb.)	7410 kg (16,336 lb.)	7323 kg (16,145 lb.)
Tipping Load, 40-deg. Full Turn, with Tire Deflection	8865 kg (19,544 lb.)	8823 kg (19,451 lb.)	7755 kg (17,097 lb.)	7650 kg (16,865 lb.)	6891 kg (15,192 lb.)	6807 kg (15,007 lb.)
Rated Operating Load, 50% Full-Turn Tipping Load, No Tire Deflection (conforms to ISO 14397-1)*	4827 kg (10,641 lb.)	4806 kg (10,595 lb.)	4187 kg (9,230 lb.)	4137 kg (9,120 lb.)	3705 kg (8,168 lb.)	3662 kg (8,073 lb.)
Rated Operating Load, 50% Full-Turn Tipping Load, with Tire Deflection (conforms to ISO 14397-1)*	4433 kg (9,772 lb.)	4412 kg (9,726 lb.)	3878 kg (8,548 lb.)	3825 kg (8,433 lb.)	3446 kg (7,596 lb.)	3404 kg (7,503 lb.)
Operating Weight	13 844 kg (30,520 lb.)	13 879 kg (30,598 lb.)	13 992 kg (30,847 lb.)	14 032 kg (30,935 lb.)	14 178 kg (31,257 lb.)	14 218 kg (31,345 lb.)

\*Rated operating capacity based on Deere attachments only.

Loader operating information is based on machine with identified linkage and standard equipment, PowerTech PVS 6068 (EPA Final Tier 4/EU Stage V) engine, ROPS cab, rear cast bumper/counterweight, transmission side-frame guards, bottom guards, standard tires, full fuel tank, and 79-kg (175 lb.) operator. This information is affected by changes in tires, ballast, and different attachments.

**Dimensions and Specifications with Hi-Vis Coupler and Hook-On Bucket** **544L Z-BAR / HIGH-LIFT / HIGH-LIFT PLUS**

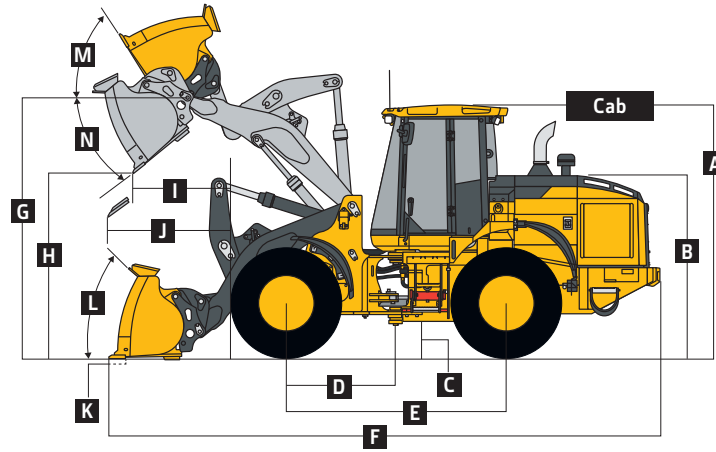

**544L Z-BAR / HIGH-LIFT / HIGH-LIFT PLUS LOADERS WITH HI-VIS COUPLER AND HOOK-ON BUCKET WITH BOLT-ON EDGE**

	Z-Bar	Z-Bar	Z-Bar	High-Lift	High-Lift	High-Lift	High-Lift Plus	High-Lift Plus
	2.3-m <sup>3</sup> (3.0 cu. yd.)	2.5-m <sup>3</sup> (3.25 cu. yd.)	3.4-m <sup>3</sup> (4.5 cu. yd.)	2.1-m <sup>3</sup> (2.75 cu. yd.)	2.3-m <sup>3</sup> (3.0 cu. yd.)	3.1-m <sup>3</sup> (4.0 cu. yd.)	1.9-m <sup>3</sup> (2.5 cu. yd.)	3.1-m <sup>3</sup> (4.0 cu. yd.)
	<i>general purpose</i>	<i>general purpose</i>	<i>light material</i>	<i>general purpose</i>	<i>general purpose</i>	<i>light material</i>	<i>general purpose</i>	<i>light material</i>
<b>A</b> Height to Top of Cab	3.33 m (10 ft. 11 in.)	3.33 m (10 ft. 11 in.)	3.33 m (10 ft. 11 in.)	3.33 m (10 ft. 11 in.)	3.33 m (10 ft. 11 in.)	3.33 m (10 ft. 11 in.)	3.33 m (10 ft. 11 in.)	3.33 m (10 ft. 11 in.)
<b>B</b> Hood Height	2.375 m (7 ft. 9 in.)	2.375 m (7 ft. 9 in.)	2.375 m (7 ft. 9 in.)	2.375 m (7 ft. 9 in.)	2.375 m (7 ft. 9 in.)	2.375 m (7 ft. 9 in.)	2.375 m (7 ft. 9 in.)	2.375 m (7 ft. 9 in.)
<b>C</b> Ground Clearance	0.40 m (15.7 in.)	0.40 m (15.7 in.)	0.40 m (15.7 in.)	0.40 m (15.7 in.)	0.40 m (15.7 in.)	0.40 m (15.7 in.)	0.40 m (15.7 in.)	0.40 m (15.7 in.)
<b>D</b> Length from Centerline to Front Axle	1.45 m (4 ft. 9 in.)	1.45 m (4 ft. 9 in.)	1.45 m (4 ft. 9 in.)	1.45 m (4 ft. 9 in.)	1.45 m (4 ft. 9 in.)	1.45 m (4 ft. 9 in.)	1.45 m (4 ft. 9 in.)	1.45 m (4 ft. 9 in.)
<b>E</b> Wheelbase	2.93 m (9 ft. 7 in.)	2.93 m (9 ft. 7 in.)	2.93 m (9 ft. 7 in.)	2.93 m (9 ft. 7 in.)	2.93 m (9 ft. 7 in.)	2.93 m (9 ft. 7 in.)	2.93 m (9 ft. 7 in.)	2.93 m (9 ft. 7 in.)
<b>F</b> Overall Length, Bucket on Ground	7.56 m (24 ft. 10 in.)	7.64 m (25 ft. 1 in.)	7.83 m (25 ft. 8 in.)	7.95 m (26 ft. 1 in.)	7.95 m (26 ft. 1 in.)	8.08 m (26 ft. 6 in.)	8.23 m (27 ft. 0 in.)	8.45 m (27 ft. 9 in.)
<b>G</b> Height to Hinge Pin, Fully Raised	3.89 m (12 ft. 9 in.)	3.89 m (12 ft. 9 in.)	3.89 m (12 ft. 9 in.)	4.17 m (13 ft. 8 in.)	4.17 m (13 ft. 8 in.)	4.17 m (13 ft. 8 in.)	4.49 m (14 ft. 9 in.)	4.49 m (14 ft. 9 in.)
<b>H</b> Dump Clearance, 45 deg., Full Height	2.76 m (9 ft. 1 in.)	2.70 m (8 ft. 10 in.)	2.58 m (8 ft. 6 in.)	3.04 m (10 ft. 0 in.)	3.04 m (10 ft. 0 in.)	2.96 m (9 ft. 9 in.)	3.43 m (11 ft. 3 in.)	3.28 m (10 ft. 9 in.)
<b>I</b> Reach, 45-deg. Dump, Full Height	1.06 m (3 ft. 6 in.)	1.12 m (3 ft. 8 in.)	1.25 m (4 ft. 1 in.)	1.19 m (3 ft. 11 in.)	1.19 m (3 ft. 11 in.)	1.29 m (4 ft. 3 in.)	1.17 m (3 ft. 10 in.)	1.33 m (4 ft. 5 in.)
<b>J</b> Reach, 45-deg. Dump, 2.13-m (7 ft. 0 in.) Clearance	1.54 m (5 ft. 1 in.)	1.56 m (5 ft. 1 in.)	1.62 m (5 ft. 4 in.)	1.87 m (6 ft. 2 in.)	1.87 m (6 ft. 2 in.)	1.92 m (6 ft. 4 in.)	2.13 m (7 ft. 0 in.)	2.23 m (7 ft. 4 in.)
<b>K</b> Maximum Digging Depth	0.1 m (4 in.)	0.11 m (4 in.)	0.11 m (5 in.)	0.2 m (8 in.)	0.2 m (8 in.)	0.2 m (8 in.)	0.2 m (8 in.)	0.21 m (8 in.)
<b>L</b> Maximum Rollback at Ground Level	44 deg.	44 deg.	44 deg.	48 deg.	48 deg.	48 deg.	49 deg.	49 deg.
<b>M</b> Maximum Rollback, Boom Fully Raised	60 deg.	60 deg.	60 deg.	60 deg.	60 deg.	60 deg.	61 deg.	61 deg.
<b>N</b> Maximum Bucket Dump Angle, Fully Raised	48 deg.	48 deg.	48 deg.	46 deg.	46 deg.	46 deg.	45 deg.	45 deg.
Loader Clearance Circle, Bucket Carry Position	11.60 m (38 ft. 1 in.)	11.60 m (38 ft. 0 in.)	11.88 m (39 ft. 0 in.)	11.78 m (38 ft. 8 in.)	11.86 m (38 ft. 11 in.)	12.22 m (40 ft. 1 in.)	12.12 m (39 ft. 9 in.)	12.62 m (41 ft. 5 in.)
<b>Specifications with Bucket with Bolt-On Edge</b>								
Capacity, Heaped	2.3 m <sup>3</sup> (3.0 cu. yd.)	2.5 m <sup>3</sup> (3.25 cu. yd.)	3.4 m <sup>3</sup> (4.5 cu. yd.)	2.1 m <sup>3</sup> (2.75 cu. yd.)	2.3 m <sup>3</sup> (3.0 cu. yd.)	3.1 m <sup>3</sup> (4.0 cu. yd.)	1.9 m <sup>3</sup> (2.5 cu. yd.)	3.1 m <sup>3</sup> (4.0 cu. yd.)
Capacity, Struck	1.9 m <sup>3</sup> (2.4 cu. yd.)	2.1 m <sup>3</sup> (2.7 cu. yd.)	2.9 m <sup>3</sup> (3.8 cu. yd.)	1.9 m <sup>3</sup> (2.4 cu. yd.)	1.9 m <sup>3</sup> (2.4 cu. yd.)	2.5 m <sup>3</sup> (3.3 cu. yd.)	1.6 m <sup>3</sup> (2.1 cu. yd.)	2.5 m <sup>3</sup> (3.3 cu. yd.)
Bucket Weight with Bolt-On Cutting Edge	1489 kg (3,283 lb.)	1537 kg (3,388 lb.)	1747 kg (3,850 lb.)	1454 kg (3,205 lb.)	1489 kg (3,283 lb.)	1683 kg (3,711 lb.)	1385 kg (3,052 lb.)	1683 kg (3,711 lb.)
Bucket Width	2.68 m (8 ft. 10 in.)	2.68 m (8 ft. 10 in.)	2.89 m (9 ft. 6 in.)	2.55 m (8 ft. 4 in.)	2.68 m (8 ft. 10 in.)	2.89 m (9 ft. 6 in.)	2.55 m (8 ft. 4 in.)	2.89 m (9 ft. 6 in.)
Breakout Force	12 307 kg (27,131 lb.)	11 539 kg (25,439 lb.)	10 013 kg (22,074 lb.)	12 179 kg (26,849 lb.)	12 155 kg (26,797 lb.)	10 907 kg (24,045 lb.)	13 305 kg (29,333 lb.)	11 028 kg (24,313 lb.)
Tipping Load, Straight, No Tire Deflection	10 362 kg (22,844 lb.)	10 250 kg (22,597 lb.)	9912 kg (21,853 lb.)	8963 kg (19,759 lb.)	8910 kg (19,642 lb.)	8663 kg (19,099 lb.)	8085 kg (17,825 lb.)	7679 kg (16,614 lb.)
Tipping Load, Straight, with Tire Deflection	9789 kg (21,581 lb.)	9675 kg (21,330 lb.)	9321 kg (20,549 lb.)	8508 kg (18,757 lb.)	8460 kg (18,651 lb.)	8199 kg (18,076 lb.)	7713 kg (17,004 lb.)	7290 kg (15,774 lb.)

While general information, pictures, and descriptions are provided, some illustrations and text may include product options and accessories NOT AVAILABLE in all regions, and in some countries products and accessories may require modifications or additions to ensure compliance with the local regulations of those countries.

**Dimensions and Specifications with Hi-Vis Coupler and Hook-On Bucket (continued)**

**544L Z-BAR / HIGH-LIFT / HIGH-LIFT PLUS**

	Z-Bar	Z-Bar	Z-Bar	High-Lift	High-Lift	High-Lift	High-Lift Plus	High-Lift Plus
	2.3-m <sup>3</sup> (3.0 cu. yd.)	2.5-m <sup>3</sup> (3.25 cu. yd.)	3.4-m <sup>3</sup> (4.5 cu. yd.)	2.1-m <sup>3</sup> (2.75 cu. yd.)	2.3-m <sup>3</sup> (3.0 cu. yd.)	3.1-m <sup>3</sup> (4.0 cu. yd.)	1.9-m <sup>3</sup> (2.5 cu. yd.)	3.1-m <sup>3</sup> (4.0 cu. yd.)
<b>Specifications with Bucket with Bolt-On Edge (continued)</b>	<i>general purpose</i>	<i>general purpose</i>	<i>light material</i>	<i>general purpose</i>	<i>general purpose</i>	<i>light material</i>	<i>general purpose</i>	<i>light material</i>
Tipping Load, 40-deg. Full Turn, No Tire Deflection	8931 kg (19,690 lb.)	8827 kg (19,459 lb.)	8499 kg (18,736 lb.)	7686 kg (16,945 lb.)	7635 kg (16,833 lb.)	7390 kg (16,293 lb.)	6899 kg (15,209 lb.)	6501 kg (14,040 lb.)
Tipping Load, 40-deg. Full Turn, with Tire Deflection	8181 kg (18,036 lb.)	8073 kg (17,798 lb.)	7731 kg (17,044 lb.)	7083 kg (15,615 lb.)	7035 kg (15,510 lb.)	6771 kg (14,927 lb.)	6393 kg (14,094 lb.)	5988 kg (12,884 lb.)
Rated Operating Load, 50% Full-Turn	4466 kg (9,845 lb.)	4413 kg (9,730 lb.)	4249 kg (9,368 lb.)	3843 kg (8,473 lb.)	3818 kg (8,417 lb.)	3695 kg (8,146 lb.)	3449 kg (7,604 lb.)	3251 kg (7,020 lb.)
Tipping Load, No Tire Deflection (conforms to ISO 14397-1)*								
Rated Operating Load, 50% Full-Turn Tipping Load, with Tire Deflection (conforms to ISO 14397-1)*	4091 kg (9,018 lb.)	4037 kg (8,899 lb.)	3866 kg (8,522 lb.)	3542 kg (7,808 lb.)	3518 kg (7,755 lb.)	3386 kg (7,464 lb.)	3197 kg (7,047 lb.)	2994 kg (6,442 lb.)
Operating Weight	14 258 kg (31,433 lb.)	14 305 kg (31,538 lb.)	14 515 kg (32,000 lb.)	14 411 kg (31,771 lb.)	14 446 kg (31,849 lb.)	14 641 kg (32,277 lb.)	14 528 kg (32,029 lb.)	14 827 kg (32,827 lb.)

Loader operating information is based on machine with identified linkage and standard equipment, PowerTech PVS 6068 (EPA Final Tier 4/EU Stage V) engine, ROPS cab, rear cast bumper/counterweight, transmission side-frame guards, bottom guards, standard tires, full fuel tank, and 79-kg (175 lb.) operator. This information is affected by changes in tires, ballast, and different attachments.

\*Rated operating capacity based on Deere attachments only.

**Dimensions and Specifications with Hi-Vis Coupler and Hook-On Construction Forks**

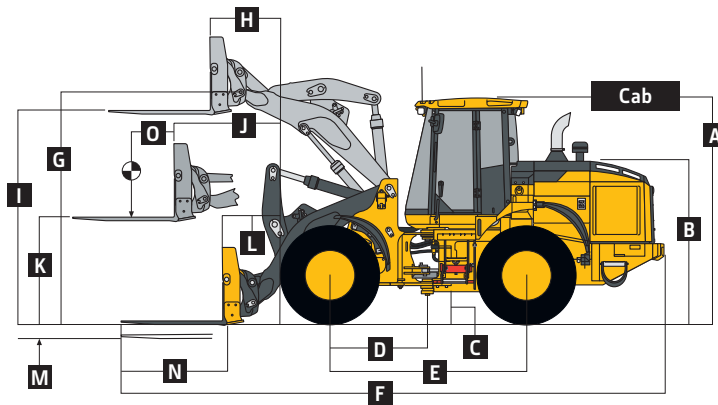

**544L Z-BAR / HIGH-LIFT / HIGH-LIFT PLUS LOADERS WITH HI-VIS COUPLER AND HOOK-ON CONSTRUCTION FORKS**

	Z-Bar	Z-Bar	High-Lift	High-Lift	High-Lift Plus	High-Lift Plus
	1.52-m (60 in.)	1.83-m (72 in.)	1.52-m (60 in.)	1.83-m (72 in.)	1.52-m (60 in.)	1.83-m (72 in.)
<b>Dimensions with Forks</b>	<i>tine length</i>	<i>tine length</i>	<i>tine length</i>	<i>tine length</i>	<i>tine length</i>	<i>tine length</i>
A Height to Top of Cab	3.33 m (10 ft. 11 in.)	3.33 m (10 ft. 11 in.)	3.33 m (10 ft. 11 in.)	3.33 m (10 ft. 11 in.)	3.33 m (10 ft. 11 in.)	3.33 m (10 ft. 11 in.)
B Hood Height	2.375 m (7 ft. 9 in.)	2.375 m (7 ft. 9 in.)	2.375 m (7 ft. 9 in.)	2.375 m (7 ft. 9 in.)	2.375 m (7 ft. 9 in.)	2.375 m (7 ft. 9 in.)
C Ground Clearance	0.40 m (15.7 in.)	0.40 m (15.7 in.)	0.40 m (15.7 in.)	0.40 m (15.7 in.)	0.40 m (15.7 in.)	0.40 m (15.7 in.)
D Length from Centerline to Front Axle	1.45 m (4 ft. 9 in.)	1.45 m (4 ft. 9 in.)	1.45 m (4 ft. 9 in.)	1.45 m (4 ft. 9 in.)	1.45 m (4 ft. 9 in.)	1.45 m (4 ft. 9 in.)
E Wheelbase	2.93 m (9 ft. 7 in.)	2.93 m (9 ft. 7 in.)	2.93 m (9 ft. 7 in.)	2.93 m (9 ft. 7 in.)	2.93 m (9 ft. 7 in.)	2.93 m (9 ft. 7 in.)
F Overall Length, Forks on Ground	8.29 m (27 ft. 2 in.)	8.59 m (28 ft. 2 in.)	8.68 m (28 ft. 6 in.)	8.98 m (29 ft. 6 in.)	9.04 m (29 ft. 8 in.)	9.35 m (30 ft. 8 in.)
G Height to Hinge Pin, Fully Raised	3.89 m (12 ft. 9 in.)	3.89 m (12 ft. 9 in.)	4.17 m (13 ft. 8 in.)	4.17 m (13 ft. 8 in.)	4.49 m (14 ft. 9 in.)	4.49 m (14 ft. 9 in.)
H Reach, Fully Raised	0.80 m (31 in.)	0.80 m (31 in.)	0.92 m (3 ft. 0 in.)	0.92 m (3 ft. 0 in.)	0.97 m (3 ft. 2 in.)	0.97 m (3 ft. 2 in.)
I Fork Height, Fully Raised	3.56 m (11 ft. 8 in.)	3.56 m (11 ft. 8 in.)	3.84 m (12 ft. 7 in.)	3.84 m (12 ft. 7 in.)	4.16 m (13 ft. 8 in.)	4.16 m (13 ft. 8 in.)
J Maximum Reach, Fork Level	1.59 m (5 ft. 3 in.)	1.59 m (5 ft. 3 in.)	1.89 m (6 ft. 2 in.)	1.89 m (6 ft. 2 in.)	2.16 m (7 ft. 1 in.)	2.16 m (7 ft. 1 in.)
K Fork Height, Maximum Reach	1.66 m (5 ft. 5 in.)	1.66 m (5 ft. 5 in.)	1.66 m (5 ft. 5 in.)	1.66 m (5 ft. 5 in.)	1.66 m (5 ft. 5 in.)	1.66 m (5 ft. 5 in.)
L Reach, Ground Level	1.03 m (3 ft. 5 in.)	1.03 m (3 ft. 5 in.)	1.40 m (4 ft. 7 in.)	1.40 m (4 ft. 7 in.)	1.72 m (5 ft. 8 in.)	1.72 m (5 ft. 8 in.)
M Depth Below Ground	91 mm (4 in.)	91 mm (4 in.)	190 mm (7 in.)	190 mm (7 in.)	195 mm (8 in.)	195 mm (8 in.)
N Tine Length	1.52 m (60 in.)	1.83 m (72 in.)	1.52 m (60 in.)	1.83 m (72 in.)	1.52 m (60 in.)	1.83 m (72 in.)
O Load Position, 50% Tine Length	0.76 m (30 in.)	0.91 m (3 ft. 0 in.)	0.76 m (30 in.)	0.91 m (3 ft. 0 in.)	0.76 m (30 in.)	0.91 m (3 ft. 0 in.)

Dimensions and Specifications with Hi-Vis Coupler and Hook-On Construction Forks <i>(continued)</i>						
	544L Z-BAR / HIGH-LIFT / HIGH-LIFT PLUS					
	Z-Bar	Z-Bar	High-Lift	High-Lift	High-Lift Plus	High-Lift Plus
	1.52-m (60 in.)	1.83-m (72 in.)	1.52-m (60 in.)	1.83-m (72 in.)	1.52-m (60 in.)	1.83-m (72 in.)
Specifications with Forks	tine length	tine length	tine length	tine length	tine length	tine length
Tipping Load, Straight, No Tire Deflection	7263 kg (16,013 lb.)	6852 kg (15,107 lb.)	6480 kg (14,287 lb.)	6132 kg (13,520 lb.)	5909 kg (13,027 lb.)	5604 kg (12,355 lb.)
Tipping Load, Straight, with Tire Deflection	7068 kg (15,582 lb.)	6669 kg (14,703 lb.)	6309 kg (13,909 lb.)	5973 kg (13,168 lb.)	5751 kg (12,679 lb.)	5451 kg (12,017 lb.)
Tipping Load, 40-deg. Full Turn, No Tire Deflection	6261 kg (13,804 lb.)	5897 kg (13,001 lb.)	5556 kg (12,249 lb.)	5248 kg (11,569 lb.)	5033 kg (11,096 lb.)	4763 kg (10,501 lb.)
Tipping Load, 40-deg. Full Turn, with Tire Deflection	5991 kg (13,208 lb.)	5649 kg (12,454 lb.)	5319 kg (11,726 lb.)	5031 kg (11,091 lb.)	4830 kg (10,648 lb.)	4566 kg (10,066 lb.)
Rated Operating Load, 50% Full-Turn Tipping Load, with Tire Deflection (conforms to ISO 14397-1 and SAE J1197)*	2996 kg (6,604 lb.)	2825 kg (6,227 lb.)	2660 kg (5,863 lb.)	2516 kg (5,546 lb.)	2415 kg (5,324 lb.)	2283 kg (5,033 lb.)
Rated Operating Load, Rough Terrain, 60% Full-Turn Tipping Load, with Tire Deflection (conforms to EN474-3)*	3595 kg (7,925 lb.)	3389 kg (7,472 lb.)	3191 kg (7,036 lb.)	3019 kg (6,655 lb.)	2898 kg (6,389 lb.)	2740 kg (6,040 lb.)
Rated Operating Load, Firm and Level Ground, 80% Full-Turn Tipping Load, with Tire Deflection (conforms to EN474-3)*	4793 kg (10,566 lb.)	4519 kg (9,963 lb.)	4255 kg (9,381 lb.)	4025 kg (8,873 lb.)	3864 kg (8,519 lb.)	3653 kg (8,053 lb.)
Operating Weight	14 108 kg (31,103 lb.)	14 168 kg (31,236 lb.)	14 297 kg (31,520 lb.)	14 357 kg (31,652 lb.)	14 483 kg (31,930 lb.)	14 544 kg (32,063 lb.)

Loader operating information is based on machine with identified linkage and standard equipment, PowerTech PVS 6068 (EPA Final Tier 4/EU Stage V) engine, ROPS cab, rear cast bumper/counterweight, transmission side-frame guards, bottom guards, standard tires, full fuel tank, and 79-kg (175 lb.) operator. This information is affected by changes in tires, ballast, and different attachments.

\*Rated operating capacity based on Deere attachments only.

#### Adjustments to Operating Weights and Tipping Loads with Buckets

Adjustments to operating weights, tipping loads, and tires are based on Z-Bar machine with pin-on 2.3-m<sup>3</sup> (3.0 cu. yd.) general-purpose bucket with bolt-on cutting edge, ROPS cab, rear cast bumper/counterweight, transmission side-frame guards, bottom guards, standard tires, full fuel tank, and 79-kg (175 lb.) operator\*

Add (+) or deduct (-) kg (lb.) as indicated for loaders with 3-piece rims	Operating Weight	Tipping Load,		Tread Width	Width Over Tires	Vertical Height
		Straight	40-deg. Full Turn			
Michelin 20.5 R 25, 1 Star L-3 XHA2	0 kg (0 lb.)	0 kg (0 lb.)	0 kg (0 lb.)	0 mm (0 in.)	0 mm (0 in.)	0 mm (0 in.)
Bridgestone 20.5 R 25, 1 Star L-3 VJT	+4 kg (+9 lb.)	+3 kg (+6 lb.)	+2 kg (+5 lb.)	0 mm (0 in.)	+2 mm (+0.1 in.)	-41 mm (-1.6 in.)
Titan 20.5 R 25, 1 Star L-3 STL3	+11 kg (+23 lb.)	+7 kg (+16 lb.)	+7 kg (+14 lb.)	0 mm (0 in.)	-7 mm (-0.3 in.)	-5 mm (-0.2 in.)
Michelin 20.5 R 25, 1 Star L-2 XTLA	-152 kg (-335 lb.)	-107 kg (-235 lb.)	-94 kg (-207 lb.)	0 mm (0 in.)	+4 mm (+0.2 in.)	-11 mm (-0.4 in.)
Bridgestone 20.5 R 25, 1 Star L-2 VUT	-65 kg (-144 lb.)	-46 kg (-101 lb.)	-40 kg (-89 lb.)	0 mm (0 in.)	+3 mm (-0.1 in.)	-10 mm (-0.4 in.)
Titan 20.5 R 25, 1 Star L-2 TGD2	-85 kg (-188 lb.)	-60 kg (-132 lb.)	-53 kg (-116 lb.)	0 mm (0 in.)	-7 mm (-0.3 in.)	-10 mm (-0.4 in.)
Titan 20.5-25, 16 PR L-2	-245 kg (-541 lb.)	-172 kg (-379 lb.)	-152 kg (-335 lb.)	0 mm (0 in.)	+8 mm (+0.3 in.)	-2 mm (-0.1 in.)
Firestone 20.5-25, 16 PR L-2 SGG LD	-280 kg (-617 lb.)	-196 kg (-433 lb.)	-173 kg (-382 lb.)	0 mm (0 in.)	+5 mm (+0.2 in.)	-1 mm (0 in.)
Titan 20.5-25, 12 PR L-2	-266 kg (-587 lb.)	-187 kg (-412 lb.)	-165 kg (-363 lb.)	0 mm (0 in.)	+8 mm (+0.3 in.)	-2 mm (-0.1 in.)
Firestone 20.5-25, 16 PR L-3 SRG LD	-276 kg (-608 lb.)	-194 kg (-427 lb.)	-171 kg (-376 lb.)	0 mm (0 in.)	+8 mm (+0.3 in.)	+3 mm (+0.1 in.)
Michelin 20.5 R 25, 1 Star L2 SNO-PLUS	-96 kg (-212 lb.)	-67 kg (-148 lb.)	-59 kg (-131 lb.)	0 mm (0 in.)	+6 mm (+0.2 in.)	-16 mm (-0.6 in.)
Michelin 620/75R26 MegaXbib <sup>EB</sup>	-189 kg (-417 lb.)	-133 kg (-293 lb.)	-117 kg (-258 lb.)	+187 mm (+7.4 in.)	+247 mm (+9.7 in.)	+23 mm (+0.9 in.)
Michelin 750/65R26 MegaXbib <sup>EB</sup>	+55 kg (+121 lb.)	+38 kg (+85 lb.)	+34 kg (+75 lb.)	+322 mm (+12.7 in.)	+521 mm (+20.5 in.)	+36 mm (+1.4 in.)
CaCl <sub>2</sub> in 20.5-25, L-3 Rear Tires, 75% Fill	+825 kg (+1,820 lb.)	+1157 kg (+2,551 lb.)	+1020 kg (+2,250 lb.)	N/A	N/A	N/A

\*May change based on vehicle configuration, weight, or tire-pressure adjustments.

<sup>E</sup>Equipped with 1-piece rims.

<sup>B</sup>Requires 8-deg. rear axle stops.



While general information, pictures, and descriptions are provided, some illustrations and text may include product options and accessories NOT AVAILABLE in all regions, and in some countries products and accessories may require modifications or additions to ensure compliance with the local regulations of those countries.

**Bucket Selection Guides 544L Z-BAR / HIGH-LIFT / HIGH-LIFT PLUS**

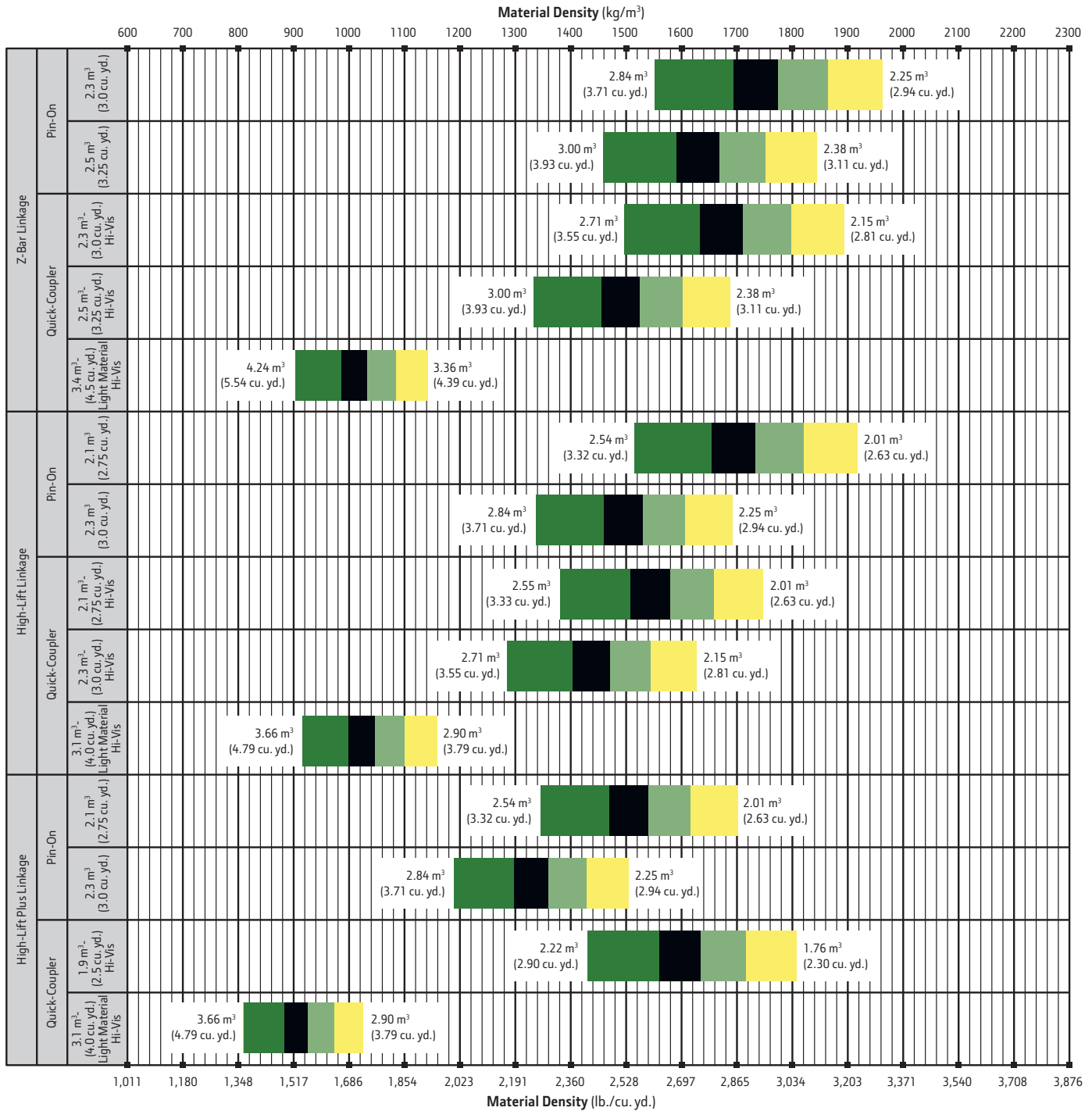

LOOSE MATERIALS		kg/m³	lb./cu. yd.	LOOSE MATERIALS		kg/m³	lb./cu. yd.
Chips, pulpwood	288	486	Limestone, coarse, sized	1570	2,646		
Cinders (coal, ashes, clinkers)	673	1,134	Limestone, mixed sizes	1682	2,835		
Clay and gravel, dry	1602	2,700	Limestone, pulverized or crushed	1362	2,295		
Clay, compact, solid	1746	2,943	Sand, damp	2083	3,510		
Clay, dry in lump loose	1009	1,701	Sand, dry	1762	2,970		
Clay, excavated in water	1282	2,160	Sand, voids, full of water	2083	3,510		
Coal, anthracite, broken, loose	865	1,458	Sandstone, quarried	1314	2,214		
Coal, bituminous, moderately wet	801	1,350	Shale, broken crushed	1362	2,295		
Earth, common loam, dry	1218	2,052	Slag, furnace granulated	1955	3,294		
Earth, mud, packed	1843	3,105	Stone or gravel, 37.5 to 87.5-mm (1.5 to 3.5 in.) size	1442	2,430		
Granite, broken	1538	2,592	Stone or gravel, 18.75-mm (0.75 in.) size	1602	2,700		
Gypsum	2275	3,834					

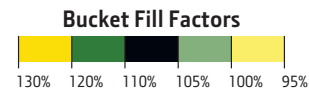



# 624L SPECIFICATIONS

While general information, pictures, and descriptions are provided, some illustrations and text may include product options and accessories NOT AVAILABLE in all regions, and in some countries products and accessories may require modifications or additions to ensure compliance with the local regulations of those countries.

<b>Engine</b>		<b>624L Z-BAR / HIGH-LIFT / HIGH-LIFT PLUS / TOOL CARRIER</b>		
Manufacturer and Model	John Deere PowerTech™ PVX 6068	Gross Peak Torque (ISO 9249)	923 Nm (681 ft.-lb.) at 1,500 rpm	
Non-Road Emission Standard	EPA Final Tier 4/EU Stage V	Net Torque Rise	58% standard	
Cylinders	6	Fuel System (electronically controlled)	High-pressure common rail	
Valves Per Cylinder	4	Lubrication	Full-flow spin-on filter and integral cooler	
Displacement	6.8 L (414 cu. in.)	Aspiration	Turbocharged, charge air cooled	
Net Peak Power (ISO 9249)	143 kW (192 hp) at 1,600 rpm	Air Cleaner	Under-hood, dual-element dry type, restriction indicator in cab monitor for service	
Gross Peak Power (ISO 9249)	152 kW (203 hp) at 1,600 rpm			
Net Peak Torque (ISO 9249)	874 Nm (644 lb.-ft.) at 1,300 rpm			
<b>Cooling</b>				
Fan Drive	Hydraulically driven, proportionally controlled, fan aft of coolers			
<b>Electrical</b>				
Electrical System	24 volt with 130-amp alternator			
Batteries (2 – 12 volt)	950 CCA (each)			
<b>Transmission System</b>				
Type	Countershaft-type PowerShift™			
Torque Converter	Single stage, single phase			
Shift Control	Electronically modulated, adaptive, load and speed dependent			
Operator Interface	Steering-column or joystick-mounted F-N-R and gear-select lever; kick-down button on hydraulic lever			
Shift Modes	Manual/auto (1st–D or 2nd–D); Quick-Shift button with 2 selectable modes: kick-down or kick-up/down; and 4 clutch cutoff settings			
	<i>Standard 5-Speed with Lockup Torque Converter</i>		<i>Optional 5-Speed without Lockup Torque Converter</i>	
Maximum Travel Speeds (with 20.5 R 25 tires)	<i>Forward</i>	<i>Reverse</i>	<i>Forward</i>	<i>Reverse</i>
Range 1	7.0 km/h (4.3 mph)	6.6 km/h (4.1 mph)	6.3 km/h (3.9 mph)	6.7 km/h (4.1 mph)
Range 2	12.1 km/h (7.5 mph)	12.8 km/h (7.9 mph)	11.4 km/h (7.0 mph)	12.0 km/h (7.4 mph)
Range 3	18.7 km/h (11.6 mph)	30.7 km/h (19.0 mph)	17.5 km/h (10.8 mph)	28.7 km/h (17.8 mph)
Range 4	29.1 km/h (18.1 mph)	N/A	27.2 km/h (16.9 mph)	N/A
Range 5	40.0 km/h (24.8 mph)	N/A	40.0 km/h (24.8 mph)	N/A
<b>Axles/Brakes</b>				
Final Drives	Heavy-duty inboard-mounted planetary			
Differentials	Hydraulic locking front with conventional rear — standard; dual locking front and rear — optional			
Rear Axle Oscillation, Stop to Stop (with 20.5 R 25 tires)	24 deg. (12 deg. each direction)			
Brakes (conform to ISO 3450)				
Service	Hydraulically actuated, spring-retracted, self-adjusting inboard sun-shaft mounted, oil cooled, single disc			
Parking	Automatic spring applied, hydraulically released, driveline mounted, oil-cooled, multi disc			
<b>Tires/Wheels (see page 32 for complete tire adjustments)</b>				
	<i>Tread Width</i>	<i>Width Over Tires</i>		
Michelin 20.5 R 25, 1 Star L-3 XHA2	2053 mm (80.8 in.)	2657 mm (104.6 in.)		
<b>Serviceability</b>				
<b>Refill Capacities</b>				
Fuel Tank (with lockable cap)	299 L (79 gal.)	Axle Oil (each)		
Cooling System	36.5 L (38.6 qt.)	Front	22 L (23 qt.)	
Diesel Exhaust Fluid (DEF)	15.6 L (16.5 qt.)	Rear	17 L (18 qt.)	
Engine Oil with Vertical Spin-On Filter	19.5 L (20.6 qt.)	Hydraulic Reservoir and Filter		
Transmission Reservoir with Vertical Filter	27 L (28.5 qt.)	Park Brake Oil (wet disc)		
			0.3 L (10 oz.)	
<b>Hydraulic System/Steering</b>				
Pump (loader and steering)	Variable-displacement, axial-piston pump; closed-center, pressure-compensating system			
Maximum Rated Flow at 6895 kPa (1,000 psi) and 2,200 rpm	261 L/m (69 gpm)			
System Relief Pressure (loader and steering)	24 821 kPa (3,675 psi)			
Loader Controls	2-function valve, joystick control or fingertip controls, hydraulic-function enable/disable, optional 3rd- and 4th-function valve with auxiliary lever			
Steering (conforms to ISO 5010)	Steering-column-mounted, twist-grip shift lever; Quick-Shift button on hydraulic lever			
Type	Power, fully hydraulic			
Articulation Angle	80-deg. arc (40 deg. each direction)			
Turning Radius (measured to centerline of outside tire)	5.27 m (17 ft. 4 in.)			
Hydraulic Cycle Times	<i>Z-Bar / High-Lift / High-Lift Plus</i>	<i>Tool Carrier</i>		
Raise	5.5 sec.	5.8 sec.		
Dump	2.0 sec.	2.5 sec.		
Lower (power down)	4.0 sec.	4.0 sec.		
Total	11.5 sec.	12.3 sec.		

# 624L SPECIFICATIONS



While general information, pictures, and descriptions are provided, some illustrations and text may include product options and accessories NOT AVAILABLE in all regions, and in some countries products and accessories may require modifications or additions to ensure compliance with the local regulations of those countries.

## Dimensions and Specifications with Pin-On Bucket

### 624L Z-BAR / HIGH-LIFT / HIGH-LIFT PLUS / TOOL CARRIER

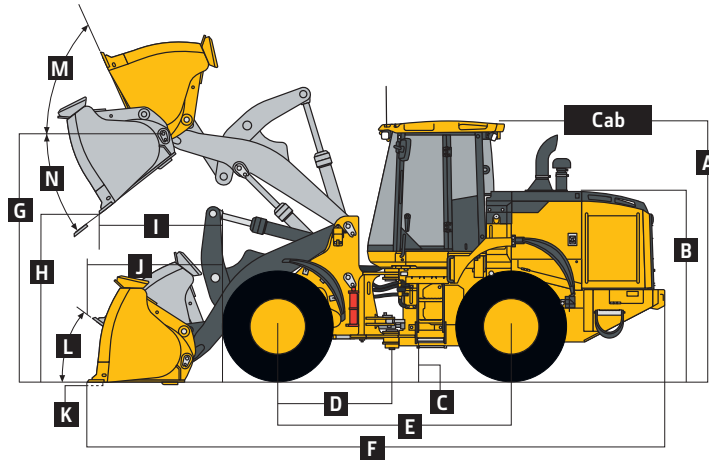

### 624L Z-BAR / HIGH-LIFT / HIGH-LIFT PLUS LOADERS WITH PIN-ON BUCKET WITH BOLT-ON EDGE

	Z-Bar 2.7-m <sup>3</sup> (3.5 cu. yd.) <i>general purpose</i>	Z-Bar 2.9-m <sup>3</sup> (3.75 cu. yd.) <i>general purpose</i>	High-Lift 2.7-m <sup>3</sup> (3.5 cu. yd.) <i>general purpose</i>	High-Lift 2.9-m <sup>3</sup> (3.75 cu. yd.) <i>general purpose</i>	High-Lift Plus 2.7-m <sup>3</sup> (3.5 cu. yd.) <i>general purpose</i>	High-Lift Plus 2.9-m <sup>3</sup> (3.75 cu. yd.) <i>general purpose</i>
<b>A</b> Height to Top of Cab	3.40 m (11 ft. 2 in.)	3.40 m (11 ft. 2 in.)	3.40 m (11 ft. 2 in.)	3.40 m (11 ft. 2 in.)	3.40 m (11 ft. 2 in.)	3.40 m (11 ft. 2 in.)
<b>B</b> Hood Height	2.46 m (8 ft. 1 in.)	2.46 m (8 ft. 1 in.)	2.46 m (8 ft. 1 in.)	2.46 m (8 ft. 1 in.)	2.46 m (8 ft. 1 in.)	2.46 m (8 ft. 1 in.)
<b>C</b> Ground Clearance	384 mm (15.1 in.)	384 mm (15.1 in.)	384 mm (15.1 in.)	384 mm (15.1 in.)	384 mm (15.1 in.)	384 mm (15.1 in.)
<b>D</b> Length from Centerline to Front Axle	1.52 m (5 ft. 0 in.)	1.52 m (5 ft. 0 in.)	1.52 m (5 ft. 0 in.)	1.52 m (5 ft. 0 in.)	1.52 m (5 ft. 0 in.)	1.52 m (5 ft. 0 in.)
<b>E</b> Wheelbase	3.09 m (10 ft. 1 in.)	3.09 m (10 ft. 1 in.)	3.09 m (10 ft. 1 in.)	3.09 m (10 ft. 1 in.)	3.09 m (10 ft. 1 in.)	3.09 m (10 ft. 1 in.)
<b>F</b> Overall Length, Bucket on Ground	7.76 m (25 ft. 6 in.)	7.83 m (25 ft. 8 in.)	8.22 m (27 ft. 0 in.)	8.22 m (27 ft. 0 in.)	8.52 m (27 ft. 11 in.)	8.58 m (28 ft. 2 in.)
<b>G</b> Height to Hinge Pin, Fully Raised	3.96 m (13 ft. 0 in.)	3.96 m (13 ft. 0 in.)	4.32 m (14 ft. 2 in.)	4.32 m (14 ft. 2 in.)	4.57 m (15 ft. 0 in.)	4.57 m (15 ft. 0 in.)
<b>H</b> Dump Clearance, 45 deg., Full Height	2.84 m (9 ft. 4 in.)	2.80 m (9 ft. 2 in.)	3.20 m (10 ft. 6 in.)	3.16 m (10 ft. 4 in.)	3.46 m (11 ft. 4 in.)	3.41 m (11 ft. 2 in.)
<b>I</b> Reach, 45-deg. Dump, Full Height	1.07 m (3 ft. 6 in.)	1.12 m (3 ft. 8 in.)	1.21 m (4 ft. 0 in.)	1.25 m (4 ft. 1 in.)	1.22 m (4 ft. 0 in.)	1.27 m (4 ft. 2 in.)
<b>J</b> Reach, 45-deg. Dump, 2.13-m (7 ft. 0 in.) Clearance	1.59 m (5 ft. 2 in.)	1.61 m (5 ft. 3 in.)	1.98 m (6 ft. 6 in.)	2.00 m (6 ft. 7 in.)	2.20 m (7 ft. 2 in.)	2.22 m (7 ft. 3 in.)
<b>K</b> Maximum Digging Depth	0.10 m (4 in.)	0.11 m (4 in.)	0.20 m (8 in.)	0.21 m (8 in.)	0.20 m (8 in.)	0.20 m (8 in.)
<b>L</b> Maximum Rollback at Ground Level	44 deg.	44 deg.	48 deg.	48 deg.	49 deg.	49 deg.
<b>M</b> Maximum Rollback, Boom Fully Raised	60 deg.	60 deg.	60 deg.	60 deg.	60 deg.	60 deg.
<b>N</b> Maximum Bucket Dump Angle, Fully Raised	48 deg.	48 deg.	46 deg.	46 deg.	45 deg.	45 deg.
Loader Clearance Circle, Bucket Carry Position	12.02 m (39 ft. 5 in.)	12.04 m (39 ft. 6 in.)	12.32 m (40 ft. 5 in.)	12.5 m (41 ft. 0 in.)	12.66 m (41 ft. 6 in.)	12.78 m (41 ft. 11 in.)
<b>Specifications with Bucket with Bolt-On Edge</b>						
Capacity, Heaped	2.7 m <sup>3</sup> (3.5 cu. yd.)	2.9 m <sup>3</sup> (3.75 cu. yd.)	2.7 m <sup>3</sup> (3.5 cu. yd.)	2.9 m <sup>3</sup> (3.75 cu. yd.)	2.7 m <sup>3</sup> (3.5 cu. yd.)	2.9 m <sup>3</sup> (3.75 cu. yd.)
Capacity, Struck	2.2 m <sup>3</sup> (2.9 cu. yd.)	2.4 m <sup>3</sup> (3.1 cu. yd.)	2.2 m <sup>3</sup> (2.9 cu. yd.)	2.4 m <sup>3</sup> (3.1 cu. yd.)	2.2 m <sup>3</sup> (2.9 cu. yd.)	2.4 m <sup>3</sup> (3.1 cu. yd.)
Bucket Weight with Bolt-On Cutting Edge	1196 kg (2,637 lb.)	1239 kg (2,732 lb.)	1196 kg (2,637 lb.)	1239 kg (2,732 lb.)	1196 kg (2,637 lb.)	1239 kg (2,732 lb.)
Bucket Width	2.69 m (8 ft. 10 in.)	2.69 m (8 ft. 10 in.)	2.69 m (8 ft. 10 in.)	2.69 m (8 ft. 10 in.)	2.69 m (8 ft. 10 in.)	2.69 m (8 ft. 10 in.)
Breakout Force	13 605 kg (29,994 lb.)	12 929 kg (28,503 lb.)	13 443 kg (29,638 lb.)	12 774 kg (28,163 lb.)	13 510 kg (29,785 lb.)	12 839 kg (28,304 lb.)
Tipping Load, Straight, No Tire Deflection	13 205 kg (29,113 lb.)	13 116 kg (28,915 lb.)	11 132 kg (24,541 lb.)	11 060 kg (24,383 lb.)	10 297 kg (22,701 lb.)	10 231 kg (22,555 lb.)
Tipping Load, Straight, with Tire Deflection	12 435 kg (27,414 lb.)	12 345 kg (27,216 lb.)	10 563 kg (23,287 lb.)	10 488 kg (23,122 lb.)	9792 kg (21,588 lb.)	9723 kg (21,436 lb.)
Tipping Load, 40-deg. Full Turn, No Tire Deflection	11 439 kg (25,218 lb.)	11 359 kg (25,042 lb.)	9595 kg (21,153 lb.)	9530 kg (21,010 lb.)	8837 kg (19,483 lb.)	8778 kg (19,351 lb.)
Tipping Load, 40-deg. Full Turn, with Tire Deflection	10 425 kg (22,983 lb.)	10 338 kg (22,791 lb.)	8820 kg (19,445 lb.)	8754 kg (19,299 lb.)	8145 kg (17,957 lb.)	8091 kg (17,838 lb.)
Rated Operating Load, 50% Full-Turn Tipping Load, No Tire Deflection (conforms to ISO 14397-1)*	5719 kg (12,609 lb.)	5680 kg (12,521 lb.)	4797 kg (10,576 lb.)	4765 kg (10,505 lb.)	4419 kg (9,741 lb.)	4389 kg (9,676 lb.)
Rated Operating Load, 50% Full-Turn Tipping Load, with Tire Deflection (conforms to ISO 14397-1)*	5213 kg (11,492 lb.)	5169 kg (11,396 lb.)	4410 kg (9,722 lb.)	4377 kg (9,650 lb.)	4073 kg (8,978 lb.)	4046 kg (8,919 lb.)
Operating Weight	15 747 kg (34,715 lb.)	15 790 kg (34,810 lb.)	15 953 kg (35,171 lb.)	15 996 kg (35,266 lb.)	16 195 kg (35,703 lb.)	16 238 kg (35,798 lb.)

Loader operating information is based on machine with identified linkage and standard equipment, PowerTech PVX 6068 (EPA Final Tier 4/EU Stage V) engine, ROPS cab, rear cast bumper/counterweight, transmission side-frame guards, bottom guards, standard tires, full fuel tank, and 79-kg (175 lb.) operator. This information is affected by changes in tires, ballast, and different attachments, and assumes no tire deflection per the standard ISO 14397-1 section 5.

\*Rated operating capacity based on Deere attachments only.

**Dimensions and Specifications with Hi-Vis Coupler and Hook-On Bucket** **624L Z-BAR / HIGH-LIFT / HIGH-LIFT PLUS / TOOL CARRIER**

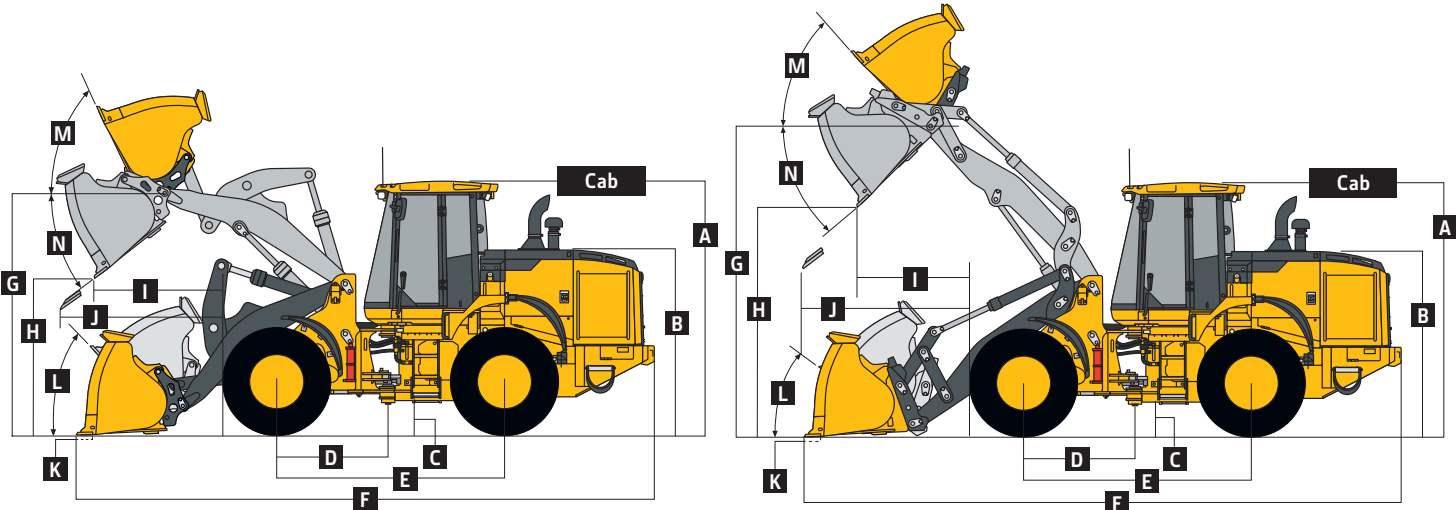

**624L Z-BAR / HIGH-LIFT / HIGH-LIFT PLUS LOADERS WITH HI-VIS COUPLER AND HOOK-ON BUCKET WITH BOLT-ON EDGE**

**624L TOOL-CARRIER LOADER WITH HI-VIS COUPLER AND HOOK-ON BUCKET WITH BOLT-ON EDGE**

	Z-Bar 2.7-m <sup>3</sup> (3.5 cu. yd.) <i>general purpose</i>	Z-Bar 4.0-m <sup>3</sup> (5.25 cu. yd.) <i>light material</i>	High-Lift 2.5-m <sup>3</sup> (3.25 cu. yd.) <i>general purpose</i>	High-Lift 3.4-m <sup>3</sup> (4.5 cu. yd.) <i>light material</i>	High-Lift Plus 2.3-m <sup>3</sup> (3.0 cu. yd.) <i>general purpose</i>	High-Lift Plus 3.1-m <sup>3</sup> (4.0 cu. yd.) <i>light material</i>	Tool Carrier 2.7-m <sup>3</sup> (3.5 cu. yd.) <i>general purpose</i>	Tool Carrier 3.4-m <sup>3</sup> (4.5 cu. yd.) <i>light material</i>
<b>A</b> Height to Top of Cab	3.40 m (11 ft. 2 in.)	3.40 m (11 ft. 2 in.)	3.40 m (11 ft. 2 in.)	3.40 m (11 ft. 2 in.)	3.40 m (11 ft. 2 in.)	3.40 m (11 ft. 2 in.)	3.40 m (11 ft. 2 in.)	3.40 m (11 ft. 2 in.)
<b>B</b> Hood Height	2.46 m (8 ft. 1 in.)	2.46 m (8 ft. 1 in.)	2.46 m (8 ft. 1 in.)	2.46 m (8 ft. 1 in.)	2.46 m (8 ft. 1 in.)	2.46 m (8 ft. 1 in.)	2.46 m (8 ft. 1 in.)	2.46 m (8 ft. 1 in.)
<b>C</b> Ground Clearance	384 mm (15.1 in.)	384 mm (15.1 in.)	384 mm (15.1 in.)	384 mm (15.1 in.)	384 mm (15.1 in.)	384 mm (15.1 in.)	384 mm (15.1 in.)	384 mm (15.1 in.)
<b>D</b> Length from Centerline to Front Axle	1.52 m (5 ft. 0 in.)	1.52 m (5 ft. 0 in.)	1.52 m (5 ft. 0 in.)	1.52 m (5 ft. 0 in.)	1.52 m (5 ft. 0 in.)	1.52 m (5 ft. 0 in.)	1.52 m (5 ft. 0 in.)	1.52 m (5 ft. 0 in.)
<b>E</b> Wheelbase	3.09 m (10 ft. 1 in.)	3.09 m (10 ft. 1 in.)	3.09 m (10 ft. 1 in.)	3.09 m (10 ft. 1 in.)	3.09 m (10 ft. 1 in.)	3.09 m (10 ft. 1 in.)	3.09 m (10 ft. 1 in.)	3.09 m (10 ft. 1 in.)
<b>F</b> Overall Length, Bucket on Ground	7.89 m (25 ft. 11 in.)	8.04 m (26 ft. 5 in.)	8.31 m (27 ft. 3 in.)	8.50 m (27 ft. 11 in.)	8.53 m (28 ft. 0 in.)	8.66 m (28 ft. 5 in.)	7.99 m (26 ft. 2 in.)	8.13 m (26 ft. 8 in.)
<b>G</b> Height to Hinge Pin, Fully Raised	3.96 m (13 ft. 0 in.)	3.96 m (13 ft. 0 in.)	4.32 m (14 ft. 2 in.)	4.32 m (14 ft. 2 in.)	4.57 m (15 ft. 0 in.)	4.57 m (15 ft. 0 in.)	4.00 m (13 ft. 1 in.)	4.00 m (13 ft. 1 in.)
<b>H</b> Dump Clearance, 45 deg., Full Height	2.76 m (9 ft. 1 in.)	2.66 m (8 ft. 9 in.)	3.15 m (10 ft. 4 in.)	3.02 m (9 ft. 11 in.)	3.45 m (11 ft. 4 in.)	3.37 m (11 ft. 1 in.)	2.74 m (9 ft. 0 in.)	2.64 m (8 ft. 8 in.)
<b>I</b> Reach, 45-deg. Dump, Full Height	1.17 m (3 ft. 10 in.)	1.28 m (4 ft. 2 in.)	1.28 m (4 ft. 2 in.)	1.42 m (4 ft. 8 in.)	1.24 m (4 ft. 1 in.)	1.34 m (4 ft. 5 in.)	1.39 m (4 ft. 7 in.)	1.51 m (4 ft. 11 in.)
<b>J</b> Reach, 45-deg. Dump, 2.13-m (7 ft. 0 in.) Clearance	1.64 m (5 ft. 5 in.)	1.69 m (5 ft. 7 in.)	2.03 m (6 ft. 8 in.)	2.10 m (6 ft. 11 in.)	2.21 m (7 ft. 3 in.)	2.27 m (7 ft. 6 in.)	1.83 m (6 ft. 0 in.)	1.89 m (6 ft. 2 in.)
<b>K</b> Maximum Digging Depth	0.10 m (4 in.)	0.11 m (4 in.)	0.20 m (8 in.)	0.21 m (8 in.)	0.19 m (7 in.)	0.19 m (7 in.)	0.13 m (5 in.)	0.13 m (5 in.)
<b>L</b> Maximum Rollback at Ground Level	44 deg.	44 deg.	48 deg.	48 deg.	49 deg.	49 deg.	52 deg.	52 deg.
<b>M</b> Maximum Rollback, Boom Fully Raised	60 deg.	60 deg.	60 deg.	60 deg.	60 deg.	60 deg.	57 deg.	57 deg.
<b>N</b> Maximum Bucket Dump Angle, Fully Raised	48 deg.	48 deg.	46 deg.	45 deg.	45 deg.	45 deg.	50 deg.	50 deg.
Loader Clearance Circle, Bucket Carry Position	12.06 m (39 ft. 7 in.)	12.44 m (40 ft. 10 in.)	12.34 m (40 ft. 6 in.)	12.80 m (42 ft. 0 in.)	12.76 m (41 ft. 11 in.)	13.00 m (42 ft. 8 in.)	12.24 m (40 ft. 2 in.)	12.5 m (41 ft. 0 in.)

While general information, pictures, and descriptions are provided, some illustrations and text may include product options and accessories NOT AVAILABLE in all regions, and in some countries products and accessories may require modifications or additions to ensure compliance with the local regulations of those countries.

**Dimensions and Specifications with Hi-Vis Coupler and Hook-On**

**Bucket (continued)**

**624L Z-BAR / HIGH-LIFT / HIGH-LIFT PLUS / TOOL CARRIER**

	Z-Bar	Z-Bar	High-Lift	High-Lift	High-Lift Plus	High-Lift Plus	Tool Carrier	Tool Carrier
	2.7-m <sup>3</sup>		2.5-m <sup>3</sup>		2.3-m <sup>3</sup>		2.7-m <sup>3</sup>	
	(3.5 cu. yd.)	4.0-m <sup>3</sup>	(3.25 cu. yd.)	3.4-m <sup>3</sup>	(3.0 cu. yd.)	3.1-m <sup>3</sup>	(3.5 cu. yd.)	3.4-m <sup>3</sup>
	general	(5.25 cu. yd.)	general	(4.5 cu. yd.)	general	(4.0 cu. yd.)	general	(4.5 cu. yd.)
<b>Specifications with Bucket with Bolt-On Edge</b>	purpose	light material	purpose	light material	purpose	light material	purpose	light material
Capacity, Heaped	2.7 m <sup>3</sup>	4.0 m <sup>3</sup>	2.5 m <sup>3</sup>	3.4 m <sup>3</sup>	2.3 m <sup>3</sup>	3.1 m <sup>3</sup>	2.7 m <sup>3</sup>	3.4 m <sup>3</sup>
	(3.5 cu. yd.)	(5.25 cu. yd.)	(3.25 cu. yd.)	(4.5 cu. yd.)	(3.0 cu. yd.)	(4.0 cu. yd.)	(3.5 cu. yd.)	(4.5 cu. yd.)
Capacity, Struck	2.17 m <sup>3</sup>	3.46 m <sup>3</sup>	2.1 m <sup>3</sup>	2.9 m <sup>3</sup>	1.9 m <sup>3</sup>	2.6 m <sup>3</sup>	1.9 m <sup>3</sup>	2.9 m <sup>3</sup>
	(2.8 cu. yd.)	(4.53 cu. yd.)	(2.7 cu. yd.)	(3.8 cu. yd.)	(2.4 cu. yd.)	(3.4 cu. yd.)	(2.4 cu. yd.)	(3.8 cu. yd.)
Bucket Weight with Bolt-On	1655 kg	1925 kg	1633 kg	1843 kg	1586 kg	1780 kg	1437 kg	1626 kg
Cutting Edge	(3,649 lb.)	(4,245 lb.)	(3,601 lb.)	(4,063 lb.)	(3,496 lb.)	(3,924 lb.)	(3,167 lb.)	(3,584 lb.)
Bucket Width	2.68 m	3.05 m	2.69 m	2.89 m	2.69 m	2.89 m	2.68 m	2.89 m
	(8 ft. 10 in.)	(10 ft. 0 in.)	(8 ft. 10 in.)	(9 ft. 6 in.)	(8 ft. 10 in.)	(9 ft. 6 in.)	(8 ft. 10 in.)	(9 ft. 6 in.)
Breakout Force	12 161 kg	10 789 kg	13 052 kg	10 709 kg	13 266 kg	11 874 kg	11 477 kg	10 290 kg
	(26,810 lb.)	(23,785 lb.)	(28,776 lb.)	(23,610 lb.)	(29,246 lb.)	(23,731 lb.)	(25,302 lb.)	(22,686 lb.)
Tipping Load, Straight, No Tire Deflection	12 357 kg	11 990 kg	10 624 kg	10 177 kg	9779 kg	9547 kg	11 577 kg	11 544 kg
	(27,242 lb.)	(26,434 lb.)	(23,422 lb.)	(22,437 lb.)	(21,559 lb.)	(20,701 lb.)	(25,523 lb.)	(25,450 lb.)
Tipping Load, Straight, with Tire Deflection	11 613 kg	11 220 kg	10 074 kg	9600 kg	9294 kg	9042 kg	10 920 kg	10 854 kg
	(25,602 lb.)	(24,736 lb.)	(22,209 lb.)	(21,164 lb.)	(20,490 lb.)	(19,577 lb.)	(24,074 lb.)	(23,929 lb.)
Tipping Load, 40-deg. Full Turn, No Tire Deflection	10 652 kg	10 292 kg	9130 kg	8690 kg	8348 kg	8120 kg	9993 kg	9939 kg
	(23,483 lb.)	(22,690 lb.)	(20,127 lb.)	(19,158 lb.)	(18,405 lb.)	(17,581 lb.)	(22,031 lb.)	(21,912 lb.)
Tipping Load, 40-deg. Full Turn, with Tire Deflection	9663 kg	9273 kg	8385 kg	7911 kg	7686 kg	7437 kg	9108 kg	9006 kg
	(21,303 lb.)	(20,443 lb.)	(18,486 lb.)	(17,441 lb.)	(16,945 lb.)	(16,032 lb.)	(20,080 lb.)	(19,855 lb.)
Rated Operating Load, 50% Full-Turn	5326 kg	5146 kg	4565 kg	4345 kg	4174 kg	4060 kg	4997 kg	4970 kg
Tipping Load, No Tire Deflection	(11,742 lb.)	(11,345 lb.)	(10,064 lb.)	(9,579 lb.)	(9,203 lb.)	(8,790 lb.)	(11,015 lb.)	(10,956 lb.)
(conforms to ISO 14397-1)*								
Rated Operating Load, 50% Full-Turn	4832 kg	4637 kg	4193 kg	3956 kg	3843 kg	3719 kg	4554 kg	4503 kg
Tipping Load, with Tire Deflection	(10,652 lb.)	(10,222 lb.)	(9,243 lb.)	(8,720 lb.)	(8,472 lb.)	(8,016 lb.)	(10,040 lb.)	(9,927 lb.)
(conforms to ISO 14397-1)*								
Operating Weight	16 225 kg	16 495 kg	16 410 kg	16 620 kg	16 605 kg	16 799 kg	15 939 kg	16 128 kg
	(35,769 lb.)	(36,365 lb.)	(36,178 lb.)	(36,641 lb.)	(36,607 lb.)	(37,174 lb.)	(35,140 lb.)	(35,556 lb.)

Loader operating information is based on machine with identified linkage and standard equipment, PowerTech PVX 6068 (EPA Final Tier 4/EU Stage V) engine, ROPS cab, rear cast bumper/counterweight, transmission side-frame guards, bottom guards, standard tires, full fuel tank, and 79-kg (175 lb.) operator. This information is affected by changes in tires, ballast, and different attachments, and assumes no tire deflection per the standard ISO 14397-1 section 5.

\*Rated operating capacity based on Deere attachments only.

**Dimensions and Specifications with Hi-Vis Coupler and Hook-On Construction Forks** **624L Z-BAR / HIGH-LIFT / HIGH-LIFT PLUS / TOOL CARRIER**

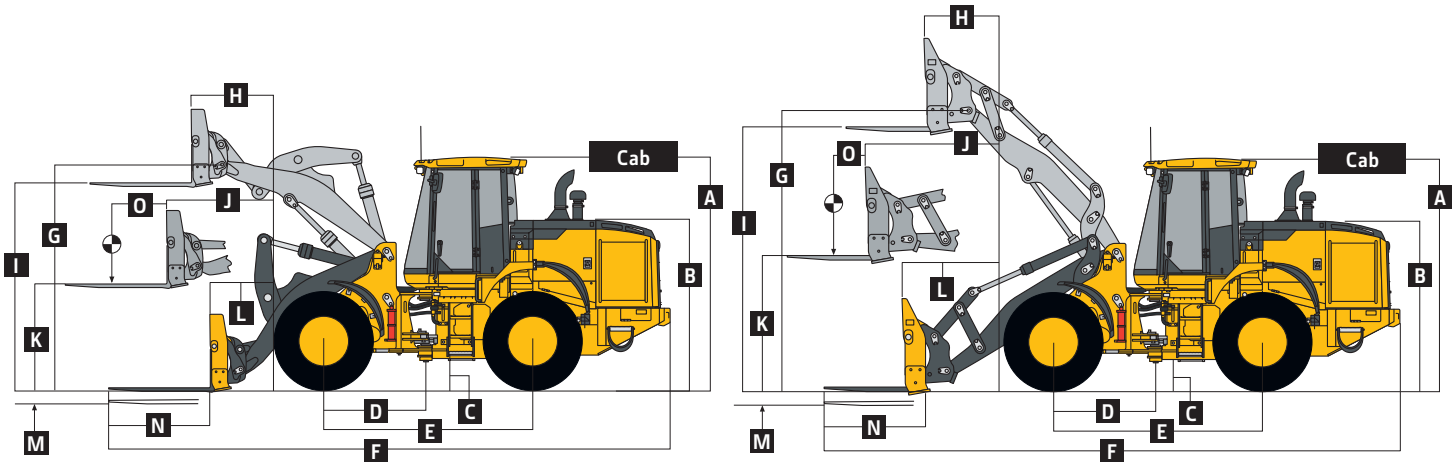

**624L Z-BAR / HIGH-LIFT / HIGH-LIFT PLUS LOADERS WITH HI-VIS COUPLER AND HOOK-ON CONSTRUCTION FORKS**

**624L TOOL-CARRIER LOADER WITH HI-VIS COUPLER AND HOOK-ON CONSTRUCTION FORKS**

	Z-Bar 1.52-m (60 in.)	Z-Bar 1.83-m (72 in.)	High-Lift 1.52-m (60 in.)	High-Lift 1.83-m (72 in.)	High-Lift Plus 1.52-m (60 in.)	High-Lift Plus 1.83-m (72 in.)	Tool Carrier 1.52-m (60 in.)	Tool Carrier 1.83-m (72 in.)
<b>Dimensions with Forks</b>	<i>tine length</i>	<i>tine length</i>	<i>tine length</i>	<i>tine length</i>	<i>tine length</i>	<i>tine length</i>	<i>tine length</i>	<i>tine length</i>
<b>A</b> Height to Top of Cab	3.40 m (11 ft. 2 in.)	3.40 m (11 ft. 2 in.)	3.40 m (11 ft. 2 in.)	3.40 m (11 ft. 2 in.)	3.40 m (11 ft. 2 in.)	3.40 m (11 ft. 2 in.)	3.40 m (11 ft. 2 in.)	3.40 m (11 ft. 2 in.)
<b>B</b> Hood Height	2.46 m (8 ft. 1 in.)	2.46 m (8 ft. 1 in.)	2.46 m (8 ft. 1 in.)	2.46 m (8 ft. 1 in.)	2.46 m (8 ft. 1 in.)	2.46 m (8 ft. 1 in.)	2.46 m (8 ft. 1 in.)	2.46 m (8 ft. 1 in.)
<b>C</b> Ground Clearance	384 mm (15.1 in.)	384 mm (15.1 in.)	384 mm (15.1 in.)	384 mm (15.1 in.)	384 mm (15.1 in.)	384 mm (15.1 in.)	384 mm (15.1 in.)	384 mm (15.1 in.)
<b>D</b> Length from Centerline to Front Axle	1.52 m (5 ft. 0 in.)	1.52 m (5 ft. 0 in.)	1.52 m (5 ft. 0 in.)	1.52 m (5 ft. 0 in.)	1.52 m (5 ft. 0 in.)	1.52 m (5 ft. 0 in.)	1.52 m (5 ft. 0 in.)	1.52 m (5 ft. 0 in.)
<b>E</b> Wheelbase	3.09 m (10 ft. 1 in.)	3.09 m (10 ft. 1 in.)	3.09 m (10 ft. 1 in.)	3.09 m (10 ft. 1 in.)	3.09 m (10 ft. 1 in.)	3.09 m (10 ft. 1 in.)	3.09 m (10 ft. 1 in.)	3.09 m (10 ft. 1 in.)
<b>F</b> Overall Length, Forks on Ground	8.50 m (27 ft. 11 in.)	8.80 m (28 ft. 11 in.)	8.96 m (29 ft. 5 in.)	9.26 m (30 ft. 5 in.)	9.25 m (30 ft. 4 in.)	9.56 m (31 ft. 4 in.)	8.63 m (28 ft. 4 in.)	8.94 m (29 ft. 4 in.)
<b>G</b> Height to Hinge Pin, Fully Raised	3.96 m (13 ft. 0 in.)	3.96 m (13 ft. 0 in.)	4.32 m (14 ft. 2 in.)	4.32 m (14 ft. 2 in.)	4.57 m (15 ft. 0 in.)	4.57 m (15 ft. 0 in.)	4.00 m (13 ft. 1 in.)	4.00 m (13 ft. 1 in.)
<b>H</b> Reach, Fully Raised	0.81 m (32 in.)	0.81 m (32 in.)	0.95 m (3 ft. 1 in.)	0.95 m (3 ft. 1 in.)	0.96 m (3 ft. 2 in.)	0.96 m (3 ft. 2 in.)	1.05 m (3 ft. 5 in.)	1.05 m (3 ft. 5 in.)
<b>I</b> Fork Height, Fully Raised	3.64 m (11 ft. 11 in.)	3.64 m (11 ft. 11 in.)	4.00 m (13 ft. 2 in.)	4.00 m (13 ft. 2 in.)	4.25 m (13 ft. 11 in.)	4.25 m (13 ft. 11 in.)	3.72 m (12 ft. 2 in.)	3.72 m (12 ft. 2 in.)
<b>J</b> Maximum Reach, Fork Level	1.62 m (5 ft. 4 in.)	1.62 m (5 ft. 4 in.)	1.98 m (6 ft. 6 in.)	1.98 m (6 ft. 6 in.)	2.18 m (7 ft. 2 in.)	2.18 m (7 ft. 2 in.)	1.80 m (5 ft. 11 in.)	1.80 m (5 ft. 11 in.)
<b>K</b> Fork Height, Maximum Reach	1.69 m (5 ft. 7 in.)	1.69 m (5 ft. 7 in.)	1.69 m (5 ft. 7 in.)	1.69 m (5 ft. 7 in.)	1.69 m (5 ft. 7 in.)	1.69 m (5 ft. 7 in.)	1.80 m (5 ft. 11 in.)	1.80 m (5 ft. 11 in.)
<b>L</b> Reach, Ground Level	1.06 m (3 ft. 6 in.)	1.06 m (3 ft. 6 in.)	1.49 m (4 ft. 11 in.)	1.49 m (4 ft. 11 in.)	1.73 m (5 ft. 8 in.)	1.73 m (5 ft. 8 in.)	1.21 m (4 ft. 0 in.)	1.21 m (4 ft. 0 in.)
<b>M</b> Depth Below Ground	77 mm (3 in.)	77 mm (3 in.)	181 mm (7 in.)	181 mm (7 in.)	173 mm (7 in.)	173 mm (7 in.)	173 mm (7 in.)	173 mm (7 in.)
<b>N</b> Tine Length	1.52 m (60 in.)	1.83 m (72 in.)	1.52 m (60 in.)	1.83 m (72 in.)	1.52 m (60 in.)	1.83 m (72 in.)	1.52 m (60 in.)	1.83 m (72 in.)
<b>O</b> Load Position, 50% Tine Length	0.76 m (30 in.)	0.91 m (3 ft. 0 in.)	0.76 m (30 in.)	0.91 m (3 ft. 0 in.)	0.76 m (30 in.)	0.91 m (3 ft. 0 in.)	0.76 m (30 in.)	0.91 m (3 ft. 0 in.)

**Dimensions and Specifications  
with Hi-Vis Coupler and Hook-On**

**Construction Forks (continued)**

**624L Z-BAR / HIGH-LIFT / HIGH-LIFT PLUS / TOOL CARRIER**

	Z-Bar	Z-Bar	High-Lift	High-Lift	High-Lift Plus	High-Lift Plus	Tool Carrier	Tool Carrier
	1.52-m	1.83-m	1.52-m	1.83-m	1.52-m	1.83-m	1.52-m	1.83-m
	(60 in.)	(72 in.)	(60 in.)	(72 in.)	(60 in.)	(72 in.)	(60 in.)	(72 in.)
	tine length	tine length	tine length	tine length	tine length	tine length	tine length	tine length
<b>Specifications with Forks</b>								
Tipping Load, Straight, No Tire Deflection	8808 kg (19,418 lb.)	8328 kg (18,360 lb.)	7736 kg (17,054 lb.)	7342 kg (16,186 lb.)	7296 kg (16,085 lb.)	6937 kg (15,293 lb.)	8505 kg (18,750 lb.)	8061 kg (17,771 lb.)
Tipping Load, Straight, with Tire Deflection	8553 kg (18,856 lb.)	8091 kg (17,838 lb.)	7515 kg (16,568 lb.)	7134 kg (15,728 lb.)	7104 kg (15,662 lb.)	6759 kg (14,901 lb.)	8283 kg (18,261 lb.)	7851 kg (17,308 lb.)
Tipping Load, 40-deg. Full Turn, No Tire Deflection	7602 kg (16,760 lb.)	7178 kg (15,825 lb.)	6639 kg (14,636 lb.)	6291 kg (13,869 lb.)	6232 kg (13,739 lb.)	5915 kg (13,041 lb.)	7350 kg (16,204 lb.)	6957 kg (15,338 lb.)
Tipping Load, 40-deg. Full Turn, with Tire Deflection	7251 kg (15,986 lb.)	6858 kg (15,119 lb.)	6330 kg (13,955 lb.)	6006 kg (13,241 lb.)	5946 kg (13,109 lb.)	5643 kg (12,441 lb.)	7023 kg (15,483 lb.)	6648 kg (14,656 lb.)
Rated Operating Load, 50% Full-Turn Tipping Load, with Tire Deflection (conforms to ISO 14397-1 and SAE J1197)*	3626 kg (7,993 lb.)	3429 kg (7,560 lb.)	3165 kg (6,978 lb.)	3003 kg (6,620 lb.)	2973 kg (6,554 lb.)	2822 kg (6,220 lb.)	3512 kg (7,742 lb.)	3324 kg (7,328 lb.)
Rated Operating Load, Rough Terrain, 60% Full-Turn Tipping Load, with Tire Deflection (conforms to EN474-3)*	4351 kg (9,591 lb.)	4115 kg (9,072 lb.)	3798 kg (8,373 lb.)	3604 kg (7,945 lb.)	3568 kg (7,865 lb.)	3386 kg (7,464 lb.)	4214 kg (9,290 lb.)	3989 kg (8,794 lb.)
Rated Operating Load, Firm and Level Ground, 80% Full-Turn Tipping Load, with Tire Deflection (conforms to EN474-3)*	5801 kg (12,789 lb.)	5486 kg (12,095 lb.)	5064 kg (11,164 lb.)	4805 kg (10,593 lb.)	4757 kg (10,487 lb.)	4514 kg (9,953 lb.)	5618 kg (12,386 lb.)	5318 kg (11,725 lb.)
Operating Weight	16 005 kg (35,286 lb.)	16 066 kg (35,420 lb.)	16 213 kg (35,744 lb.)	16 272 kg (35,875 lb.)	16 454 kg (36,274 lb.)	16 516 kg (36,412 lb.)	15 721 kg (34,659 lb.)	15 807 kg (34,849 lb.)

Loader operating information is based on machine with identified linkage and standard equipment, PowerTech PVX 6068 (EPA Final Tier 4/EU Stage V) engine, ROPS cab, rear cast bumper/counterweight, transmission side-frame guards, bottom guards, standard tires, full fuel tank, and 79-kg (175 lb.) operator. This information is affected by changes in tires, ballast, and different attachments.

\*Rated operating capacity based on Deere attachments only.

### Adjustments to Operating Weights and Tipping Loads with Buckets

#### 624L Z-BAR / HIGH-LIFT / HIGH-LIFT PLUS / TOOL CARRIER

Adjustments to operating weights, tipping loads, and tires are based on Z-Bar machine with pin-on 2.7-m<sup>3</sup> (3.5 cu. yd.) general-purpose bucket with bolt-on cutting edge, ROPS cab, rear cast bumper/counterweight, transmission side-frame guards, bottom guards, standard tires, full fuel tank, and 79-kg (175 lb.) operator\*

Add (+) or deduct (-) kg (lb.) as indicated for loaders with 3-piece rims	Operating Weight	Tipping Load, Straight	Tipping Load, 40-deg. Full Turn	Tread Width	Width Over Tires	Vertical Height
Michelin 20.5 R 25, 1 Star L-3 XHA2	0 kg (0 lb.)	0 kg (0 lb.)	0 kg (0 lb.)	0 mm (0 in.)	0 mm (0 in.)	0 mm (0 in.)
Bridgestone 20.5 R 25, 1 Star L-3 VJT	+4 kg (+9 lb.)	+3 kg (+6 lb.)	+3 kg (+6 lb.)	0 mm (0 in.)	+3 mm (+0.1 in.)	-41 mm (-1.6 in.)
Titan 20.5 R 25, 1 Star L-3 STL3	+8 kg (+19 lb.)	+6 kg (+13 lb.)	+5 kg (+13 lb.)	0 mm (0 in.)	-6 mm (-0.2 in.)	-7 mm (-0.3 in.)
Michelin 20.5 R 25, 1 Star L-2 XTLA	-152 kg (-335 lb.)	-110 kg (-242 lb.)	-97 kg (-214 lb.)	0 mm (0 in.)	+5 mm (+0.2 in.)	-10 mm (-0.4 in.)
Bridgestone 20.5 R 25, 1 Star L-2 VUT	-68 kg (-149 lb.)	-49 kg (-108 lb.)	-43 kg (-95 lb.)	0 mm (0 in.)	+4 mm (+0.2 in.)	-10 mm (-0.4 in.)
Titan 20.5 R 25, 1 Star L-2 TGD2	-116 kg (-255 lb.)	-84 kg (-184 lb.)	-74 kg (-162 lb.)	0 mm (0 in.)	-6 mm (-0.2 in.)	-10 mm (-0.4 in.)
Firestone 20.5-25, 16 PR L-3 SRG Bias	-276 kg (-608 lb.)	-200 kg (-440 lb.)	-176 kg (-388 lb.)	0 mm (0 in.)	+9 mm (+0.4 in.)	+6 mm (+0.2 in.)
Titan 20.5-25, 16 PR L-2 Bias	-232 kg (-511 lb.)	+168 kg (+370 lb.)	-148 kg (-326 lb.)	0 mm (0 in.)	+9 mm (+0.4 in.)	-1 mm (0 in.)
Firestone 20.5-25, 16 PR L-2 SGG Bias	-280 kg (-617 lb.)	-203 kg (-446 lb.)	-178 kg (-393 lb.)	0 mm (0 in.)	+6 mm (+0.2 in.)	+2 mm (+0.1 in.)
Michelin 600/65 R 25, 1 Star L-3T XLD <sup>§</sup>	+16 kg (+36 lb.)	+12 kg (+26 lb.)	+10 kg (+23 lb.)	0 mm (0 in.)	+95 mm (+3.7 in.)	-31 mm (-1.2 in.)
Michelin 20.5 R 25, L2T XSNO-PLUS	-96 kg (-212 lb.)	-69 kg (-153 lb.)	-61 kg (-135 lb.)	0 mm (0 in.)	+7 mm (+0.3 in.)	-33 mm (-1.3 in.)
Michelin 620/75R26 MegaXbib <sup>§</sup>	-207 kg (-457 lb.)	-150 kg (-331 lb.)	-132 kg (-291 lb.)	+86 mm (+3.4 in.)	+147 mm (+5.8 in.)	+23 mm (+0.9 in.)
Michelin 750/65R26 MegaXbib <sup>§</sup>	+37 kg (+81 lb.)	+27 kg (+58 lb.)	+23 kg (+51 lb.)	+222 mm (+8.7 in.)	+422 mm (+16.6 in.)	+36 mm (+1.4 in.)
CaCl <sub>2</sub> in 20.5-25, L-3 Rear Tires, 75% Fill	+825 kg (+1,820 lb.)	+1193 kg (+2,631 lb.)	+1051 kg (+2,318 lb.)	N/A	N/A	N/A

\*May change based on vehicle configuration, weight, or tire-pressure adjustments.

<sup>§</sup>CaCl<sub>2</sub> not recommended.

<sup>§</sup>Equipped with 1-piece rims.

<sup>§</sup>Requires 8-deg. rear axle stops.



**Bucket Selection Guides 624L Z-BAR / HIGH-LIFT / HIGH-LIFT PLUS / TOOL CARRIER**

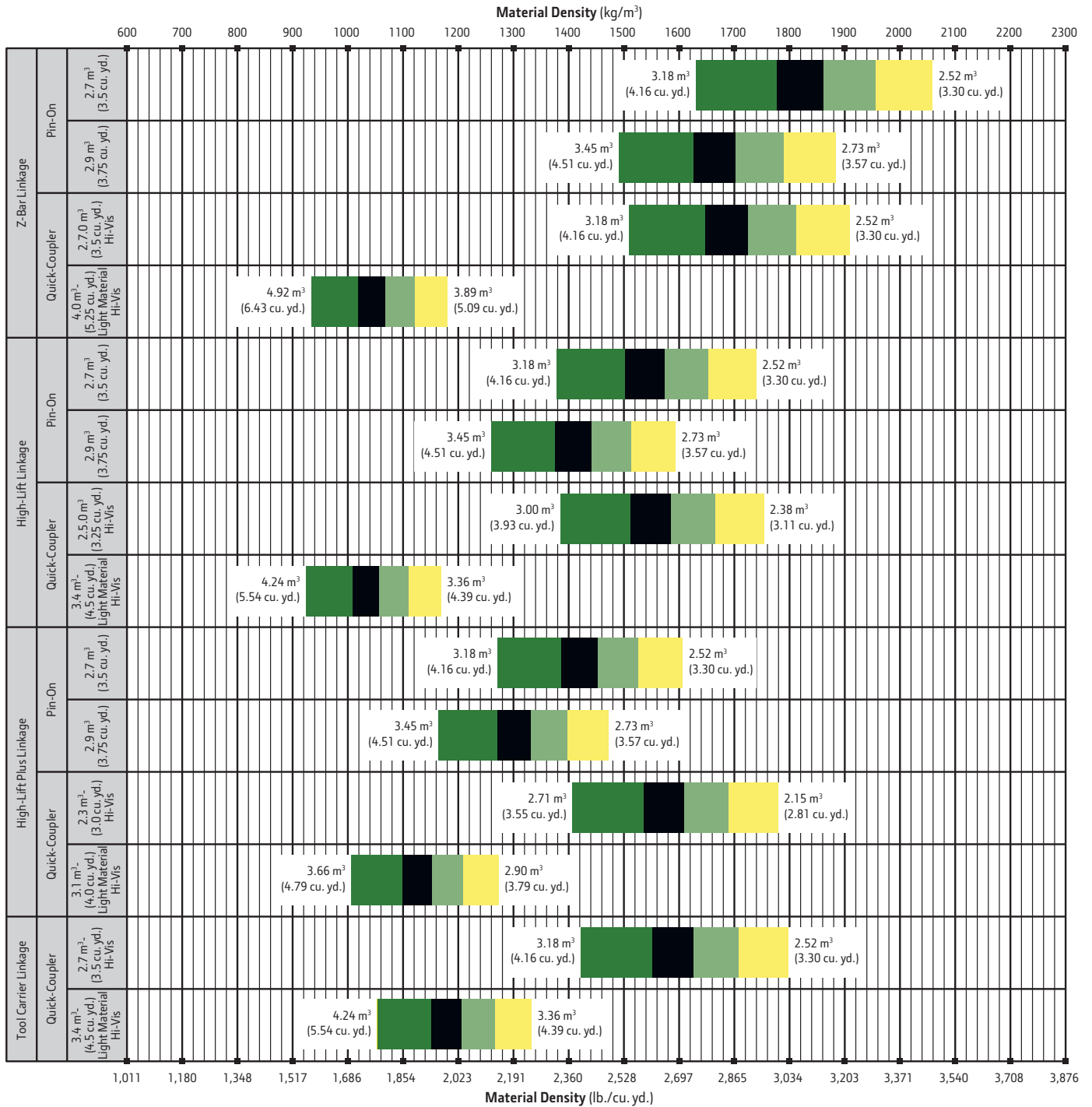

LOOSE MATERIALS		kg/m <sup>3</sup>	lb./cu. yd.	LOOSE MATERIALS		kg/m <sup>3</sup>	lb./cu. yd.
Chips, pulpwood	288	486	Limestone, coarse, sized	1570	2,646		
Cinders (coal, ashes, clinkers)	673	1,134	Limestone, mixed sizes	1682	2,835		
Clay and gravel, dry	1602	2,700	Limestone, pulverized or crushed	1362	2,295		
Clay, compact, solid	1746	2,943	Sand, damp	2083	3,510		
Clay, dry in lump loose	1009	1,701	Sand, dry	1762	2,970		
Clay, excavated in water	1282	2,160	Sand, voids, full of water	2083	3,510		
Coal, anthracite, broken, loose	865	1,458	Sandstone, quarried	1314	2,214		
Coal, bituminous, moderately wet	801	1,350	Shale, broken crushed	1362	2,295		
Earth, common loam, dry	1218	2,052	Slag, furnace granulated	1955	3,294		
Earth, mud, packed	1843	3,105	Stone or gravel, 37.5 to 87.5-mm (1.5 to 3.5 in.) size	1442	2,430		
Granite, broken	1538	2,592	Stone or gravel, 18.75-mm (0.75 in.) size	1602	2,700		
Gypsum	2275	3,834					

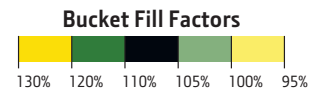

# Additional equipment

Key: ● Standard ▲ Optional or special See your John Deere dealer for further information.

524	544	624	Engine
●	●	●	Wet-sleeve cylinder liners
●	●	●	Automatic glow plugs for cold start
●	●	●	Programmable auto-idle and auto shutdown
●	●	●	Selected idle adjustment from 900–1,250 rpm
●	●	●	Starter protection
●	●	●	Automatic engine cool-down timer
●	●	●	Automatic derating for exceeded system temperatures
●	●	●	Serpentine drive belt for automatic tensioner
●	●	●	Electrical fuel-priming pump
●	●	●	Dual-stage fuel filter and water separator
●	●	●	500-hour vertical spin-on oil filter
▲	▲	▲	Engine-compartment light
▲	▲	▲	Chrome exhaust stack
▲	▲	▲	Engine-block heater (recommended for cold starts below –23 deg. C [–10 deg. F])
▲	▲	▲	Centrifugal engine air pre-cleaner
▲	▲	▲	Throttle lock
			Powertrain
●	●	●	Clutch cutoff with 4 operator settings: Automatic, level ground, small slope, or steep slope
●	●	●	Programmable maximum high gear
●	●	●	Clutch calibration engaged from monitor
●	●	●	2,000-hour vertical spin-on transmission filter
●	●	●	Transmission fill tube and sight gauge
●	●	●	Transmission diagnostic ports
●	●	●	5-speed transmission with lockup torque converter
●	▲	▲	5-speed transmission with non-lockup torque converter
●	●	●	Front locking differential
▲	▲	▲	Rear locking differential
●	●	●	Brake retractors and adjusters
▲	▲	▲	Automatic differential lock
●	●	●	Axle oil temperature sensing
▲	▲	▲	Wheel-spin control
			Quad-Cool™ Cooling System
●	●	●	Heavy-duty, trash-resistant radiator and high-ambient cooling package
●	●	●	2-side access to all coolers
●	●	●	Isolated from engine compartment
●	●	●	Engine radiator
●	●	●	Integral engine oil cooler
●	●	●	Hydraulic oil cooler (oil to air)
●	●	●	Transmission oil cooler (oil to air)
●	●	●	Charge air cooler (air to air)
●	●	●	Fuel cooler
●	●	●	Coolant recovery tank
●	●	●	Antifreeze, –37 deg. C (–34 deg. F)
●	●	●	Cool-on-demand, hydraulically driven, swing-out fan
●	●	●	Enclosed fan safety guard
▲	▲	▲	Automatic reversing fan drive
▲	▲	●	Axle and service-brake coolers

524	544	624	Hydraulics
●	●	●	Electrohydraulic (EH) controls with soft stops and adjustable settings
●	●	●	In-cab adjustable automatic return-to-dig bucket positioner
●	●	●	In-cab adjustable automatic boom-height kickout/return to carry
●	●	●	Reservoir with sight gauge and fill strainer
●	●	●	Hydraulic diagnostic ports
●	●	●	4,000-hour in-tank filter
●	●	●	2 function — joystick with F-N-R
▲	▲	▲	2 function — 2-lever fingertip controls and steering column F-N-R
▲	▲	▲	3 function — joystick with F-N-R and integrated 3rd-function roller
▲	▲	▲	3 function — 3-lever fingertip controls and steering column F-N-R
▲	▲	▲	4 function — joystick with F-N-R and integrated 3rd/4th function rollers
●	●	●	2 programmable multifunction buttons
●	●	●	Adjustable and continuous hydraulic-flow settings
●	●	●	Programmable attachment settings
▲	▲	▲	Ride control, automatic with monitor-adjustable speed settings
▲	▲	▲	Hydraulic control system for quick-coupler locking pins
▲	▲	▲	Hydra™ XR cold-temperature hydraulic fluid recommended below –25 deg. C (–13 deg. F)
			Steering Systems
●	●	●	Conventional steering wheel with spinner knob
▲	▲	▲	Secondary steering
			Electrical
●	●	●	Solid-state electrical power-distribution system
●	●	●	Lockable master electrical-disconnect switch
●	●	●	Battery-terminal safety covers
●	●	●	By-pass start safety cover at starter
●	●	●	Remote jump-start access in battery box
●	●	●	Pre-wired for beacon/strobe light
●	●	●	Lights: Halogen driving lights with guards (2) / Front (4), rear cab (2), and rear grille (2) work lights / LED front turn signals and flashers / LED stop and taillights
▲	▲	▲	Premium LED light package (all exterior lights are heavy-duty LED)
●	●	●	Programmable courtesy lights
●	●	●	Horn, electric
●	●	●	Reverse warning alarm
●	●	●	Multifunction/multi-language 178-mm (7 in.) LCD color monitor includes: Digital instruments — Analog display (hydraulic oil temperature, engine coolant temperature, transmission oil temperature, and engine oil pressure) / Digital display (engine rpm, transmission gear/direction indicator, hour meter, fuel level, diesel exhaust fluid (DEF) level, speedometer, odometer, and average fuel consumption)
▲	▲	▲	Multifunction/multi-language 127-mm (5 in.) LCD color monitor includes: Digital instruments — Analog display (hydraulic oil temperature, engine coolant temperature, transmission oil temperature, and engine oil pressure) / Digital display (engine rpm, transmission gear/direction indicator, hour meter, fuel level, DEF level, speedometer, odometer, and average fuel consumption)
▲	▲	▲	Integrated cycle counter with 5 categories
●	●	●	Indicator lights: Standard and selected options / Amber caution and red stop

While general information, pictures, and descriptions are provided, some illustrations and text may include product options and accessories NOT AVAILABLE in all regions, and in some countries products and accessories may require modifications or additions to ensure compliance with the local regulations of those countries.

Net engine power is with standard equipment including air cleaner, exhaust system, alternator, and cooling fan at test conditions per ISO 9249. No derating is required up to 3050-m (10,000 ft.) altitude. Specifications and design subject to change without notice. Specifications with the exception of bucket capacity are in accordance with all applicable ISO standards. Except where otherwise noted, these specifications are based on units with applicable linkage and standard equipment, ROPS cab, rear cast bumper/counterweight, transmission side-frame guards, bottom guards, standard tires, full fuel tank, and 79-kg (175 lb.) operator.

# Additional equipment *(cont.)*

Key: ● Standard ▲ Optional or special See your John Deere dealer for further information.

524	544	624	Electrical <i>(continued)</i>
●	●	●	Operator-warning messages
●	●	●	Built-in diagnostics: Diagnostic-code details / Sensor values / Calibrations / Individual circuit tester
▲	▲	▲	Electrical corrosion-prevention package
●	●	●	Standard AM/FM/Weather-Band (WB) radio with remote auxiliary port
▲	▲	▲	Premium AM/FM/WB radio with Bluetooth®, remote auxiliary port, and remote USB port (premium cab only)
●	●	●	24- to 12-volt, 8-amp converter and cab power ports (3)
▲	▲	▲	24- to 12-volt, 15- or 30-amp converter and cab power ports (3)
Operator's Station			
●	●	●	Standard cab with air conditioning/heater (ROPS/FOPS Level 1, isolation mounted)
▲	▲	▲	Premium cab with air conditioning/heater (ROPS/FOPS Level 1, isolation mounted)
▲	▲	▲	Automatic temperature control (premium cab only)
●	●	●	Rear window defrost vent
●	●	●	Keyless start with multiple security modes
●	●	●	Sealed-switch module with function indicators
●	●	●	Seat with backrest extension, deep foam, fabric cover, and adjustable air suspension
▲	▲	▲	Premium seat with high-wide back and headrest extension, heated and ventilated, leather/fabric cover, and adjustable heavy-duty air suspension
●	●	●	Hydraulic controls integrated to seat
●	●	●	High-visibility, bright-orange seat belt, 76 mm (3 in.), with retractor
▲	▲	▲	Seat-belt minder monitoring with JDLink™ and seat-belt indicator beacon
●	●	●	Cup holder and cup/thermos holder with retaining strap
●	●	●	Lunch-box/cooler holder with tie-down brackets
●	●	●	Coat hook
●	●	●	LED dome and reading light
●	●	●	Rubber floor mat
●	●	●	Dual-tilt steering column
●	●	●	Operator's manual storage compartment
●	●	●	Outside (2) and inside (1) rearview mirrors
▲	▲	▲	Heated outside mirrors with convex lens
▲	▲	▲	In-cab adjustable heated outside mirrors with convex lens (premium cab only)
●	●	●	Left-side operator-station access
●	●	●	Slip-resistant steps and ergonomic handholds
●	●	●	Pull-down front sun visor
●	●	●	Front and rear intermittent windshield wipers and washers
▲	▲	▲	Powered cab air pre-cleaner
▲	▲	▲	Beacon bracket only
▲	▲	▲	Beacon bracket with strobe beacon
●	●	●	Rearview camera
▲	▲	▲	Rearview camera with radar object-detection system
▲	▲	▲	Dedicated 178-mm (7 in.) rear camera display
●	●	●	Payload scale ready
▲	▲	▲	Fire extinguisher

524	544	624	Loader Linkage
●	●	●	Z-Bar loader linkage (parallel lift)
▲	▲	▲	High-Lift Z-Bar loader linkage (parallel lift)
▲	▲	▲	High-Lift Plus Z-Bar loader linkage (parallel lift)
▲	▲	▲	Tool Carrier linkage for visibility (parallel lift)
Buckets and Attachments			
▲	▲	▲	Full line of Deere pin-on buckets
▲	▲	▲	John Deere hydraulic coupler that accepts JRB-pattern attachments
▲	▲	▲	Hi-Vis hydraulic coupler which accepts Euro-pattern attachments (ISO)
▲	▲	▲	Full line of Deere hook-on buckets and forks
Overall Vehicle			
●	●	●	JDLink wireless communication system (available in specific countries; see your dealer for details)
●	●	●	NeverGrease™ rear-axle oscillation
●	●	●	Front and rear tie-downs
●	●	●	Rear cast bumper/counterweight with rear hitch and locking pin
●	●	●	Articulation locking bar
●	●	●	Loader boom service locking bar
●	●	●	40-deg. steering articulation to each side with rubber-cushion stops on frame
●	●	●	Vandal protection with lockable engine enclosures, right counterweight storage, and filler access for radiator/fuel/DEF/hydraulic transmission
●	●	●	Left-side service steps and handholds
▲	▲	▲	Right-side service steps and handrails
▲	▲	▲	Left-side close-mounted steps
●	●	●	Storage compartment
●	●	●	Fuel-tank fill strainer
●	●	●	Heavy-duty fuel-tank guard
●	●	●	DEF and ground-level fueling
●	●	●	Same-side ground-level daily servicing
●	●	●	20.5R25 tires on 3-piece rims
▲	▲	▲	Ag material-handling package
		▲	Waste handler (Z-Bar and High-Lift)
▲	▲	▲	Environmental drains and sample ports for engine, transmission, hydraulic oils, and engine coolant
●	●	●	Fenders, front narrow
▲	▲	▲	Fenders, front full width
▲	▲	▲	Fenders, front and rear full width
▲	▲	▲	Fenders, front and rear full width with mudflaps
▲	▲	▲	Less wheels and tires with 8-deg. axle stops
▲	▲	▲	Rims less tires
▲	▲	▲	Transmission side-frame and bottom guards
▲	▲	▲	Lift eyes
▲	▲	▲	License-plate bracket and light
		▲	Special guarding for waste applications

While general information, pictures, and descriptions are provided, some illustrations and text may include product options and accessories NOT AVAILABLE in all regions, and in some countries products and accessories may require modifications or additions to ensure compliance with the local regulations of those countries.

Net engine power is with standard equipment including air cleaner, exhaust system, alternator, and cooling fan at test conditions per ISO 9249. No derating is required up to 3050-m (10,000 ft.) altitude. Specifications and design subject to change without notice. Specifications with the exception of bucket capacity are in accordance with all applicable ISO standards. Except where otherwise noted, these specifications are based on units with applicable linkage and standard equipment, ROPS cab, rear cast bumper/counterweight, transmission side-frame guards, bottom guards, standard tires, full fuel tank, and 79-kg (175 lb.) operator.



**JOHN DEERE**

