

---

# **User's Manual**

## **2755 Portable Wheatstone Bridge With Murray and Varley Loop Tester**

---

Test Equipment Depot - 800.517.8431 - 99 Washington Street Melrose, MA 02176 - [TestEquipmentDepot.com](http://TestEquipmentDepot.com)

Thank you for purchasing our Portable wheatstone bridge.  
This manual describes the specifications and handling precautions of the Portable wheatstone bridge.  
Before using this product, thoroughly read this manual to understand how to use it properly.

Contact information of Yokogawa offices worldwide is provided on the following sheet.  
PIM 113-01Z2: Inquiries List of worldwide contacts

Disk No. IM 2755-97E  
7th Edition: October 2017 (YMI)  
All Rights Reserved. Copyright © 2015, Yokogawa Test & Measurement Corporation  
Printed in Japan

### **Notice regarding This User's Manual**

- The information contained in this manual is subject to change without notice.  
Furthermore, the actual display items may differ slightly from the ones appearing in this manual.
- Every effort has been made to ensure the information contained herein is accurate.  
However, should any concerns, errors, or emissions come to your attention, or if you have any comments, please contact us.
- Copying or reproduction of any or all of the content of this manual without Yokogawa's permission is strictly prohibited.

IM 2755-97E

## Regarding the Safe Use of This Product

When operating the instrument, be sure to observe the cautionary notes given below to ensure correct and safe use of the instrument. If you use the instrument in any way other than as instructed in this manual, the instrument's protective measures may be impaired. YOKOGAWA is by no means liable for any damage resulting from use of the instrument in contradiction to these cautionary notes.

- The following safety symbols are used on the instrument and in this manual.



Danger! Handle with Care.

This mark indicates that operator must refer to an explanation in the instruction manual in order to avoid risk of injury or death of personnel or damage to the instrument.



---

---

### **WARNING**

Indicates a hazard that may result in the loss of life or serious injury of the user unless the described instruction is abided by.

---

---



---

---

### **CAUTION**

Indicates a hazard that may result in an injury to the user and/or physical damage to the product or other equipment unless the described instruction is abided by.

---

---

- **Since mishandling the instrument can result in an accident that may lead to injury or death of the operator, such as an electric shock, be sure to observe the following instructions.**

## **WARNING**

---

### ● **Protective Measures**

- If a crack appears in the instrument after it has been accidentally dropped or bumped, the safety-purpose insulation may be damaged. By all means do not use the instrument, but ask the manufacturer for repair.

### ● **Connection**

- To avoid electric shock, be sure to apply protective grounding to the grounding terminal.

### ● **Measurement**

- Always maintain the instrument within the limits for allowable current, voltage and power, during operation.  
If there is more than one limit for any of these parameters, the lowest limit takes precedence.

### ● **External Power Supply**

- Only operate the instrument on a supply voltage no greater than 70 V DC.

### ● **Operating Environment**

- Do not operate the instrument in a flammable or explosive gas atmosphere.
  - Do not operate the instrument if there is any condensation on it.
- 

## **WARNING**

---

### ● **Do Not Remove the Casing or Disassemble**

Only Yokogawa service personnel are authorized to remove the casing or disassemble or modify the instrument.

Do not attempt to repair the instrument yourself, as doing so is extremely dangerous.

---

■ Since mishandling the instrument can result in an accident, such as an electric shock, that may injure the operator or damage the instrument, be sure to observe the following instructions.

---

---

 **CAUTION**

---

---

● **Batteries**

- Do not use a mixture of different types of batteries or a mixture of old and new batteries. If the instrument will not be used for a prolonged period, remove the batteries before storage. The battery fluid will leak more readily during long-term storage, resulting in an instrument malfunction.

● **Plastic Case**

- The panel and case of this instrument are made of ABS resin. Special caution must be taken to protect them from heat and organic solvent such as lacquer thinner.
- 
- 

## Handling Precautions

 **WARNING**

---

---

● **External Power Supply**

When external power supply is employed to increase sensitivity, full caution must be taken to avoid excess current flow, since all wire-wound bridge elements used in this instrument can endure up to 1 watt max.

Before higher voltage is applied, take rough balance of bridge with low voltage.

Caution must be taken not to set  $\times 1000$  dial to "0" and not to short-circuit Rx terminals.

---

---

## CAUTION

---

### ● Operation of Button Switch

- BA and GA button switches should be at OFF position after measurement.
- During measurement, BA button switch must be pressed prior to GA button switch. If this order is inverted, the movement of the galvanometer will be kicked when BA button switch is pushed due to back EMF of inductance of the object under test, and the direction of measuring dial adjustment shall be thereby misled.

### ● Lead Resistance

In measurement of resistances below 10 ohms, the lead wire resistance should not be neglected. The lead resistance compensation must be made by measuring the lead resistance separately.

---

## CONTENTS

Regarding the Safe Use of This Product . . . . .	ii
Handling Precautions . . . . .	iv
1. GENERAL . . . . .	1
2. SPECIFICATIONS . . . . .	1
3. CONSTRUCTION . . . . .	3
3.1 Front Panel. . . . .	3
3.2 External Galvanometer . . . . .	4
3.3 External Power Supply. . . . .	4
3.4 Battery (Cell) Replacement . . . . .	5
4. OPERATION . . . . .	6
4.1 Preparation. . . . .	6
4.2 Resistance Measurement . . . . .	6
4.3 To find out approximate value of Rx. . . . .	7
4.4 Interpolation . . . . .	8
4.5 Murray Loop Test . . . . .	8
4.6 Varley Loop Test. . . . .	9
5. PRINCIPLES OF OPERATION . . . . .	10

## 1. GENERAL

The 2755 Portable Wheatstone Bridge is quite convenient with general resistance measurement and fault point detection of lines by Murray and Varley loop testing methods.

## 2. SPECIFICATIONS

**Measuring Range:** 1  $\Omega$  to 10 M $\Omega$  (4 digits)

**Measuring arm:** 1  $\Omega$   $\times 10$  + 10  $\Omega$   $\times 10$  +  
100  $\Omega$   $\times 10$  + 1000  $\Omega$   $\times 10$   
(4 dials)

**Ratio arm:**  $\times 0.001$ ,  $\times 0.01$ ,  $\times 0.1$ ,  $\times 1$ ,  $\times 10$ ,  
 $\times 100$ ,  $\times 1000$  and  
for Murray loop test  
M10, M100, M1000

### Accuracy:

<b>Overall</b>	100 $\Omega$ to 100 k $\Omega$ :	$\pm 0.1\%$ of reading
	10 $\Omega$ to 1 M $\Omega$ :	$\pm 0.3\%$ of reading
	1 $\Omega$ to 10 M $\Omega$ :	$\pm 0.6\%$ of reading

<b>Measuring arm</b>	$\times 1000$ :	$\pm 0.06\%$
	$\times 100$ :	$\pm 0.1\%$
	$\times 10$ :	$\pm 0.5\%$
	$\times 1$ :	$\pm 3\%$ (Including residual resistance)

<b>Multiply dial (Ratio)</b>	$\times 0.1$ , $\times 1$ , $\times 10$ :	$\pm 0.07\%$
	$\times 100$ , $\times 0.01$ :	$\pm 0.2\%$
	$\times 1000$ , $\times 0.001$ :	$\pm 0.5\%$
	M10, M100, M1000:	$\pm 0.1\%$

### Temperature Coefficient of Resistance Elements

$\pm 5 \times 10^{-5}/^{\circ}\text{C}$  or less (at 5 to 35 $^{\circ}\text{C}$ )

$\pm 2 \times 10^{-5}/^{\circ}\text{C}$  or less (at 20 to 35 $^{\circ}\text{C}$ )

### Galvanometer

**Sensitivity:** 0.9  $\mu\text{A}/\text{div.}$  ( $\pm 20\%$ )

**Internal resistance:** 150  $\Omega$  ( $\pm 20\%$ )

**Period:** Within 2.6 seconds

**Operating Temperature:** 5 to 35°C  
**Operating Humidity:** 85% RH or less  
**Power Source:** Three 1.5V batteries (built-in) type SUM-1  
**Dimensions:** Approx. 182×226×128 mm  
**Weight :** Approx. 2 kg (4.4 lbs)  
**Accessory:** User's manual: 1 copy.  
Carrying case (B9350AW): 1pc.  
**Optional Accessory:** Carrying case: B9350AW (275600)

(Note)

\* For the measurement of more than 100 kΩ, it is recommended to use external galvanometer, which has high sensitivity.

For example, the 2707 Electronic Galvanometer (Portable type 10 μV/div. sensitivity) is suitable for above requirement.

It is possible to measure 0.1% variation of Rx value of 2 MΩ (4.5 V power supply).

### 3. CONSTRUCTION

#### 3.1 Front Panel

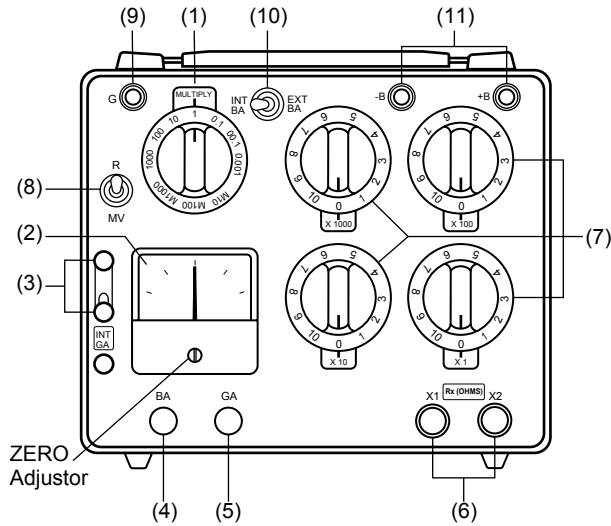

**Fig 3.1 Panel**

- (1) Multiply dial  
×0.001, ×0.01, ×0.1, ×1, ×10, ×100, ×1000  
M10, M100, M1000
- (2) Galvanometer
- (3) External galva terminals
- (4) "BA" push button switch
- (5) "GA" push button switch
- (6) Unknown resistance
- (7) Measuring arm dials
- (8) "MV-R" Selector switch
- (9) "G" terminal (Ground (Earth))
- (10) Power supply selector switch  
(Internal battery/External battery)
- (11) External battery terminals  
(Maximum 70 VDC)

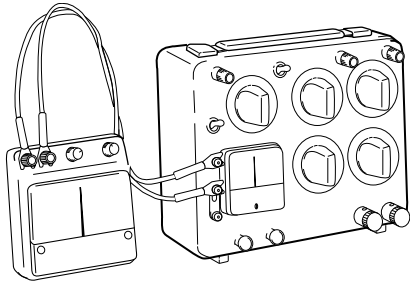

**Fig 3.2 Connection of External Galvanometer**

### 3.2 External Galvanometer

When a high sensitive galvanometer is required, move short circuiting bar and short “INT.GA.” terminals. After that, connect the galvanometer to “EXT. GA.” terminals are shown in Fig. 3.2.

### 3.3 External Power Supply

When external power supply is necessary, connect the power supply to -B and +B terminals and turn the power supply selector switch to “EXT BA”.

Minimum circuit resistance between -B and +B terminals is approximate 1010  $\Omega$  (ohms).

Maximum external power supply voltage is 70 VDC and maximum current is 60 mADC (Continuous).

1 k $\Omega$  (2 W type) protective resistance is inserted between the external power supply and bridges, so when the  $\times 1000$  dial is set to 0, the circuit is protected from overcurrent.

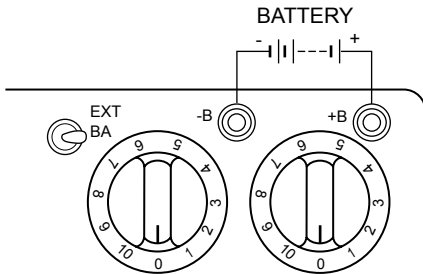
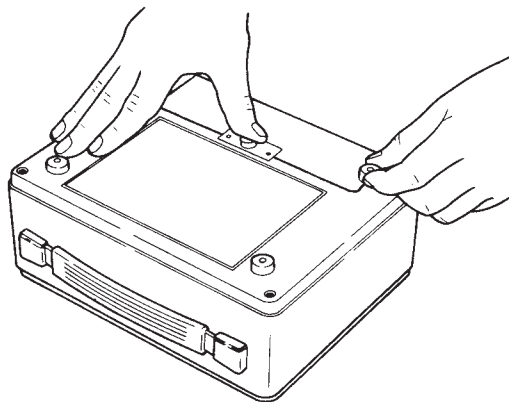

**Fig 3.3 Connection of External Battery**

### 3.4 Battery (Cell) Replacement

Remove the cell cover on the bottom of the case, by pulling leg of the cover while pushing the clamping plate towards the arrowed direction to the end.

To restore the cell cover, push the clamping plate towards the arrowed direction, insert the hollowed part of the cover under the clamping plate and press the cover down.



**Fig 3.4 Removal of Cell Cover**

### CAUTION

---

Insert the batteries with their positive and negative electrodes (polarities) positioned correctly.

---

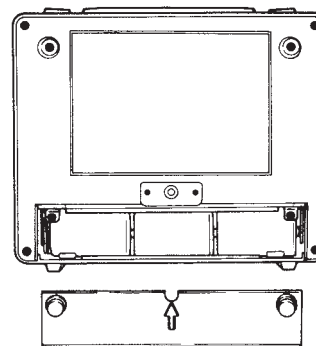

**Fig 3.5 Bottom View**

## 4. OPERATION

### 4.1 Preparation

- (1) Confirm that EX . GA terminals are perfectly short-circuited with short circuiting bar.
- (2) Confirm that the galvanomete indicates “0” by opening Rx terminals without pushing GA and BA push button switch.  
If the galvanometer does not indicate “0”, adjust the zero point by turning the zero adjustor.
- (3) GA push button switch should be at OFF position.

### 4.2 Resistance Measurement

- (1) Apply unknown resistor to Rx terminals.
- (2) Turn the selector switch to “R”
- (3) Set the MULTIPLY dial to proper range according to Table 4.1.
- (4) Set the Measuring dial at 1999 and push BA push button switch.  
Then push GA push button switch for a moment to check to which direction, + (plus) or - (minus), the galvanometer deflects

- (5) When the pointer deflects + (plus) side, increase measuring dials, and when the pointer deflects - (minus) side, decrease measuring dials.

Adjust measuring dials until the galvanometer indicates “0”.

Then, the unknown resistance value is measured by the following equation.

Rx	MULTIPLY
less than 10 $\Omega$	0.001
10 $\Omega$ to 100 $\Omega$	0.01
100 $\Omega$ to 1 k $\Omega$	0.1
1 k $\Omega$ to 10 k $\Omega$	1
10 k $\Omega$ to 100 k $\Omega$	10
100 k $\Omega$ to 1 M $\Omega$	100
1 M $\Omega$ to 10 M $\Omega$	1000

**Table 4.1 MULTIPLY Dial Setting**

$$R_x = (\text{MULTIPLY factor}) \times (\text{Total value of MEASURING DIALS}) [\text{ohms}]$$

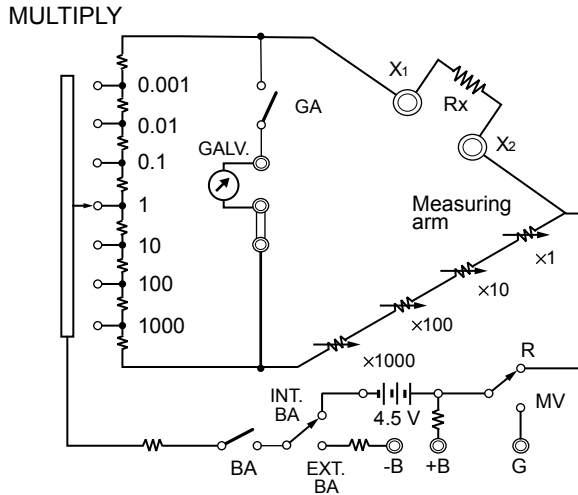

**Fig 4.1 Resistance Measurement**

### 4.3 To find out approximate value of $R_x$

When the resistance value to be measured is entirely unknown and if there is no suitable circuit tester (ohm meter) available, the following procedure shall be effected to find out approximate value of the unknown resistance.

Set MULTIPLY dial to "1" and measuring arm dials to 1000.

Pressing the BA push button switch, then lightly pressing GA push button switch to check to which direction the galvanometer deflects. When the pointer deflects to + (plus) side,  $R_x$  is higher than 1000  $\Omega$ .

Then increase MULTIPLY dial to "10" and press BA and GA push button switches again. If the galvanometer still deflects to + (plus) side, turn MULTIPLY dial to "100".

Suppose that the pointer deflects to - (minus) side by this adjustment,  $R_x$  is in the range between 10 k $\Omega$  and 100 k $\Omega$ .

On the other hand, when the galvanometer deflects to - (minus) side by the first settings,  $R_x$  is lower than 1000  $\Omega$ .

In this case, decrease MULTIPLY dial to "0.1" or "0.01" so as to make the pointer deflect to + (plus) side. Approximate value of  $R_x$  can be obtained by the above process.

## 4.4 Interpolation

There might exist a case where perfect balance of galvanometer can not be taken even by adjustment to minimum figure ( $\times 1$  dial).

Read, in such a case, the amount of unbalance from the scale of the galvanometer and estimate fractional parts of the lowest dial by proportional galvanometer deflections

## 4.5 Murray Loop Test

Simplified circuit diagram of Murray loop test is illustrated in Fig. 4.2.

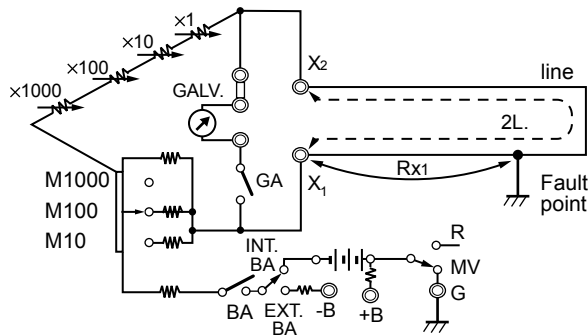

Table 4.2 Murray Loop Test

- (1) Connect the looped line under test to Rx terminals. Connect "G" terminal to the earth.
- (2) Turn the selector switch to "MV".
- (3) Set MULTIPLY dial between M10, M100 and M1000.
- (4) Press the "BA" push button switch and "GA" push button switch.  
Adjust measuring arm dials until the galvanometer indicates "0".
- (5) Obtain the value referring to the following equation:

$$Rx1 = \frac{(MULTIPLY \text{ factor})}{(MULTIPLY \text{ factor}) + (\text{Total value of MEASURING DIALS})} [ohms]$$

Rx1: Resistance between  $\times 1$  terminal and the fault point.  
2L: Total resistance of looped line under test.

## 4.6 Varley Loop Test

Simplified circuit diagram of Varley loop test is illustrated in Fig. 4.3.

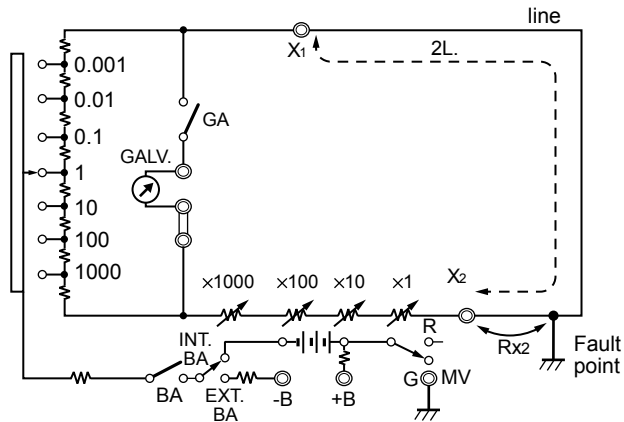

**Table 4.3 Varley Loop Test**

- (1) Connect the looped line under test to Rx terminals.  
Connect the “G” terminal to the earth.
- (2) Turn the selector switch to “MV”.
- (3) Set the MULTIPLY dial to proper range of 0.001 to 1000.

- (4) Press the “BA” push button switch and “GA” push button switch.

Adjust measuring arm dials until the galvanometer indicates “0”.

- (5) Obtain the value referring to the following equation:

$$Rx2 = \frac{2L - (\text{MULTIPLY factor}) \times (\text{Total value of MEASURING DIALS})}{1 + (\text{MULTIPLY factor})} \text{ [ohms]}$$

Rx2: Resistance between X2 terminal and the fault point.

2L: Total resistance of looped line under test.

## 5. PRINCIPLES OF OPERATION

Fig.5.1 is the theoretical diagram of Wheatstone bridge. When the current at the galvanometer is set to zero by adjusting  $R_s$ , the following equation will be established.

$$I_x \cdot R_A = I_s \cdot R_B$$

$$I_x \cdot R_x = I_s \cdot R_s$$

$$\frac{I_s}{I_x} = \frac{R_x}{R_s} = \frac{R_A}{R_B}$$

$$R_x = \frac{R_A}{R_B} R_s$$

As this 2755 Portable Wheatstone Bridge is so designed that  $R_A/R_B$  can be set within the range of 0.001 to 1000 by MULTIPLY dial, the unknown resistance value  $R_x$  can be obtained by multiplying the  $R_s$  value by the multiplying factor.

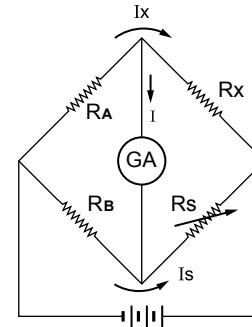

**Fig.5.1 Theoretical Circuit Diagram**

<MEMO>

Printed in Japan