

Fisher™ FIELDVUE™ DVC6200 SIS Digital Valve Controller

This manual applies to

Instrument Level	SIS	
Device Type	130a	
Hardware Revision	2	
Firmware Revision	7	
Device Revision	1	3
DD Revision	7	1

Contents

Section 1 Introduction	3
Installation, Pneumatic and Electrical Connections, and Initial Configuration	3
Scope of Manual	3
Conventions Used in this Manual	3
Description	4
Specifications	4
Related Documents	7
Educational Services	8
Section 2 Wiring Practices	9
Control System Requirements	9
HART Filter	9
Voltage Available	9
Compliance Voltage	10
Auxiliary Terminal Wiring Length Guidelines	12
Maximum Cable Capacitance	11
Local Control Panel	13
Installation	13
Electrical Connections	13
Section 3 Configuration	15
Guided Setup	15
Manual Setup	15
Mode and Protection	17
Instrument Mode	17
Write Protection	17
Instrument	17
Identification	17
Serial Numbers	18
Units	18
Terminal Box	18
Spec Sheet	18
Edit Instrument Time	18

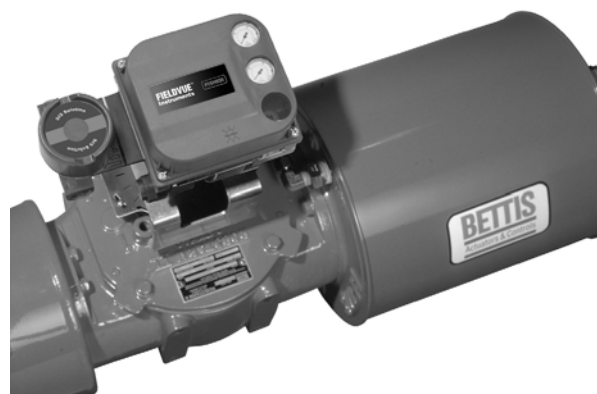

X0079

Travel/Pressure Control	19
End Point Pressure Control	19
Characterization	19
Dynamic Response	20
Travel Cutoffs	21
Tuning	21
Travel Tuning	21
Integral Settings	24
Valve and Actuator	24
SIS/Partial Stroke Test	27
Partial Stroke Test Parameters	27
Partial Stroke Parameters	28
PST Abnormal Criteria	30
PST Abort Criteria	31
PST Prohibited	31
SIS Options	32
Solenoid Valve Test	32
Instrument Configuration	33
SOV Test Parameters	33
SOV Test Alerts	34
Outputs	34
Output Terminal Configuration	34
Switch Configuration	34
HART Variable Assignments	35
Transmitter Output	35
Burst Mode	35
Alert Setup	36
Change to HART 5 / HART 7	36

Contents (continued)

Section 4 Calibration	37
Calibration Overview	37
Travel Calibration	38
Auto Calibration	38
Manual Calibration	39
Pushbutton Calibration	40
Sensor Calibration	41
Pressure Sensors	41
Analog Input Calibration	42
Relay Adjustment	43
Double-Acting Relay	43
Single-Acting Relays	44
PST Calibration	45
SOV Test Calibration	45
Section 5 Device Information, Alerts and Diagnostics	47
Overview	47
Status & Primary Purpose Variables	47
Device Information	47
Service Tools	48
Device Status	48
Alert Record	48
Alert Reporting	48
Deadband Principle of Operation	52
Diagnostics	54
Stroke Valve	54
Partial Stroke Test	54
Demand Mode Tests	55
Solenoid Valve Health Monitoring	59
Variables	59
Section 6 Maintenance and Troubleshooting	61
Replacing the Magnetic Feedback Assembly	62
Module Base Maintenance	62
Tools Required	62
Component Replacement	63
Removing the Module Base	63
Replacing the Module Base	64

Submodule Maintenance	65
I/P Converter	65
Printed Wiring Board (PWB) Assembly	67
Pneumatic Relay	68
Gauges, Pipe Plugs or Tire Valves	69
Terminal Box	69
Removing the Terminal Box	70
Replacing the Terminal Box	70
Troubleshooting	71
Checking Voltage Available	71
Restart Processor	71
DVC6200 SIS Technical Support Checklist	74
Section 7 Parts	75
Parts Ordering	75
Parts Kits	75
PWB Assembly	75
Parts List	76
Housing	76
Common Parts	77
Module Base	77
I/P Converter Assembly	77
Relay	77
Terminal Box	77
Feedback Connection Terminal Box	77
Pressure Gauges, Pipe Plugs, or Tire Valve Assemblies	78
DVC6215 Feedback Unit	78
HART Filter	78
Line Conditioner	78
Appendix A Principle of Operation	85
HART Communication	85
DVC6200 SIS Digital Valve Controller	85
Appendix B Device Communicator Menu Tree	89
Glossary	99
Index	107

Section 1 Introduction

Installation, Pneumatic and Electrical Connections, and Initial Configuration

Refer to the DVC6200 Series Quick Start Guide ([D103556X012](#)) for DVC6200 SIS installation, connection, and initial configuration information. If a copy of this quick start guide is needed scan or click the QR code at the right, contact your [Emerson sales office](#) or visit our website at Fisher.com.



Scan or click to access field support

Scope of Manual

This instruction manual is a supplement to the DVC6200 Series Quick Start Guide ([D103556X012](#)) and Safety manual ([D103601X012](#)) that ship with every instrument. This instruction manual includes product specifications, reference materials, custom setup information, maintenance procedures, and replacement part details.

This instruction manual describes using an Emerson Device Communicator to set up and calibrate the instrument. You can also use Fisher ValveLink™ software to setup, calibrate, and diagnose the valve and instrument. For information on using ValveLink software with the instrument refer to ValveLink software help or documentation.

Do not install, operate, or maintain a DVC6200 SIS digital valve controller without being fully trained and qualified in valve, actuator, and accessory installation, operation, and maintenance. **To avoid personal injury or property damage, it is important to carefully read, understand, and follow all of the contents of this manual, including all safety cautions and warnings.** If you have any questions about these instructions, contact your Emerson sales office before proceeding.

Conventions Used in this Manual

Navigation paths and fast-key sequences are included for procedures and parameters that can be accessed using the Device Communicator.

For example, to access Device Setup:

Device Communicator	Configure > Guided Setup > Device Setup (2-1-1)
---------------------	---

Refer to Appendix B for Device Communicator menu trees.

Note

Fast-key sequences are only applicable to the 475 Field Communicator. They do not apply to the Trex™ Device Communicator.

Figure 1-1. FIELDVUE DVC6200 SIS Digital Valve Controller Mounted on a Bettis Quarter-Turn Actuator

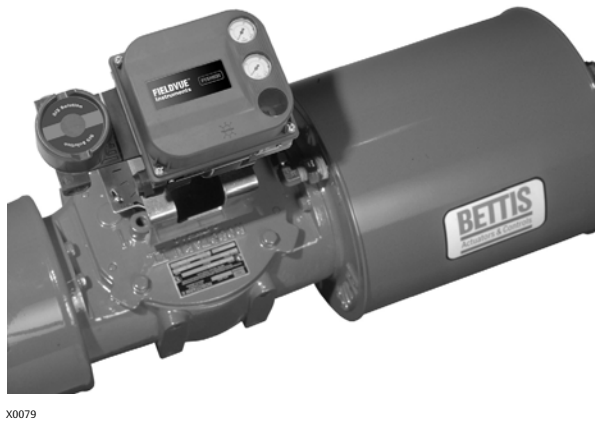

Description

DVC6200 SIS digital valve controllers (figure 1-1) are HART communicating, microprocessor-based current-to-pneumatic instruments. The DVC6200 SIS digital valve controller has three fundamental functions.

1. Modulate a pneumatic output to a valve actuator in response to a demand signal from a logic solver to move the valve to a safe state.
2. Perform periodic tests on a valve assembly to exercise the mechanical components that are prone to sticking.
3. Continuously monitor the health of the valve and report alerts.

Specifications

⚠ WARNING

Refer to table 1-1 for specifications. Incorrect configuration of a positioning instrument could result in the malfunction of the product, property damage or personal injury.

Specifications for DVC6200 SIS digital valve controllers are shown in table 1-1. Specifications for the Device Communicator can be found in the Device Communicator [quick start guide](#).

Table 1-1. Specifications

<p>Available Mounting</p> <ul style="list-style-type: none"> ■ Sliding-stem linear applications ■ Quarter-turn rotary applications ■ Integral mounting to Fisher rotary actuators ■ Integral mounting to Fisher 657/667 or GX actuators <p>DVC6200 SIS digital valve controllers can also be mounted on other actuators that comply with IEC 60534-6-1, IEC 60534-6-2, VDI/VDE-3845, and NAMUR mounting standards</p> <p>Mounting the instrument vertically, with the vent at the bottom of the assembly, or horizontally, with the vent pointing down, is recommended to allow drainage of moisture that may be introduced via the instrument air supply</p> <p>Communication Protocol</p> <ul style="list-style-type: none"> ■ HART 5 or ■ HART 7 <p>Input Signal</p> <p>Point-to-Point <i>Analog Input Signal:</i> 4-20 mA DC, nominal Minimum Voltage Available at Instrument Terminals must be 9.5 VDC for analog control, 10 VDC for HART communication <i>Minimum Control Current:</i> 4.0 mA <i>Minimum Current w/o Microprocessor Restart:</i> 3.5 mA <i>Maximum Voltage:</i> 30 VDC Overcurrent protected Reverse Polarity protected</p> <p>Multi-Drop <i>Instrument Power:</i> 11 to 30 VDC at 10 mA Reverse Polarity protected</p> <p>Supply Pressure⁽¹⁾</p> <p>Minimum Recommended: 0.3 bar (5 psig) higher than maximum actuator requirements Maximum: 10.0 bar (145 psig) or maximum pressure rating of the actuator, whichever is lower Medium: Air or Natural Gas</p> <p>Supply medium must be clean, dry and noncorrosive Per ISA Standard 7.0.01 A maximum 40 micrometer particle size in the air system is acceptable. Further filtration down to 5 micrometer particle size is recommended. Lubricant content is not to exceed 1 ppm weight (w/w) or volume (v/v) basis. Condensation in the air supply should be minimized</p>	<p>Per ISO 8573-1 <i>Maximum particle density size:</i> Class 7 <i>Oil content:</i> Class 3 <i>Pressure Dew Point:</i> Class 3 or at least 10°C less than the lowest ambient temperature expected</p> <p>Output Signal</p> <p>Pneumatic Output: up to full supply pressure <i>Minimum Span:</i> 0.4 bar (6 psig) <i>Maximum Span:</i> 9.5 bar (140 psig) <i>Action:</i> Double, Single Direct, or Single Reverse</p> <p>Electronic Output⁽²⁾</p> <ul style="list-style-type: none"> ■ Integral 4-20 mA Position Transmitter: 4-20 mA output, isolated <i>Supply Voltage:</i> 8-30 VDC <i>Reference Accuracy:</i> 1% of travel span <i>Safety Accuracy:</i> 5% of travel span <p>The position transmitter meets the requirements of NAMUR NE43; selectable to show failure high (> 22.5 mA) or failure low (< 3.6 mA). Fail high only when the positioner is powered.</p> <ul style="list-style-type: none"> ■ Integral Switch: One isolated switch, configurable throughout the calibrated travel range or actuated from a device alert <i>Off State:</i> 0 mA (nominal) <i>On State:</i> up to 1 A <i>Supply Voltage:</i> 30 VDC maximum <i>Reference Accuracy:</i> 2% of travel span <i>Safety Accuracy:</i> 5% of travel span <p>Steady State Air Consumption⁽³⁾⁽⁴⁾</p> <p>Low Bleed Relay⁽⁵⁾ <i>At 1.4 bar (20 psig) supply pressure:</i> 0.056 normal m³/hr (2.1 scfh), average <i>At 5.5 bar (80 psig) supply pressure:</i> 0.184 normal m³/hr (6.9 scfh), average</p> <p>Maximum Output Capacity⁽³⁾⁽⁴⁾</p> <p><i>At 1.4 bar (20 psig) supply pressure:</i> 10.0 normal m³/hr (375 scfh) <i>At 5.5 bar (80 psig) supply pressure:</i> 29.5 normal m³/hr (1100 scfh)</p> <p>Operating Ambient Temperature Limits⁽¹⁾⁽⁶⁾ -52 to 85°C (-62 to 185°F)</p>
--	--

-continued-

Table 1-1. Specifications (continued)

<p>Independent Linearity⁽⁷⁾ Typical Value: +/-0.50% of output span</p> <p>Electromagnetic Compatibility Meets EN 61326-1:2013 Immunity-Industrial locations per Table 2 of the EN 61326-1 standard. Performance is shown in table 1-2 below. Emissions-Class A ISM equipment rating: Group 1, Class A</p> <p>Vibration Testing Method Tested per ANSI/ISA S75.13.01 Section 5.3.5</p> <p>Input Load Impedance An equivalent impedance of 500 ohms may be used. This value corresponds to 10V @ 20 mA.</p> <p>Humidity Testing Method Tested per IEC 61514-2</p> <p>Electrical Classification Hazardous Area Approvals CSA— Intrinsicly Safe, Explosion-proof, Division 2, Dust Ignition-proof FM— Intrinsicly Safe, Explosion-proof, Dust Ignition-proof, Non-Incendive ATEX— Intrinsicly Safe, Flameproof, Type n, Dust by intrinsic safety IECEX— Intrinsicly Safe, Flameproof, Type n, Dust by intrinsic safety and enclosure Auxiliary Terminal Contact: Nominal Electrical Rating 5 V, <1 mA; It is recommended that the switch be sealed or have gold plated contacts to avoid corrosion</p> <p>Electrical Housing CSA— Type 4X, IP66 FM— Type 4X, IP66 ATEX— IP66 IECEX— IP66</p> <p>Other Classifications/Certifications Lloyds Register— Marine Type Approval CCC— China Compulsory Certification CML— Certification Management Limited (Japan)</p>	<p>CUTR— Customs Union Technical Regulations (Russia, Kazakhstan, Belarus, and Armenia) ESMA— Emirates Authority for Standardization and Metrology - ECAS-Ex (UAE) INMETRO— National Institute of Metrology, Quality, and Technology (Brazil) KOSHA— Korean Occupational Safety & Health Agency (South Korea) KTL— Korea Testing Laboratory (South Korea) NEPSI— National Supervision and Inspection Centre for Explosion Protection and Safety of Instrumentation (China) PESO CCOE— Petroleum and Explosives Safety Organisation - Chief Controller of Explosives (India) SANS— South Africa National Standards Contact your Emerson sales office for classification/certification specific information</p> <p>IEC 61010 Compliance Requirements Power Source: The loop current must be derived from a separated extra-low voltage (SELV) power source Environmental Conditions: Installation Category I</p> <p>Connections Supply Pressure: 1/4 NPT internal and integral pad for mounting Fisher 67CFR regulator Output Pressure: 1/4 NPT internal Tubing: 3/8-inch recommended Vent: 3/8 NPT internal Electrical: 1/2 NPT internal or M20</p> <p>Actuator Compatibility Sliding-Stem Linear Linear actuators with rated travel between 6.35 mm (0.25 inch) and 606 mm (23.375 inches) Quarter-Turn Rotary Rotary actuators with rated travel between 45 degrees and 180 degrees⁽⁸⁾</p> <p>Weight DVC6200 SIS <i>Aluminum:</i> 3.5 kg (7.7 lbs) <i>Stainless Steel:</i> 8.6 kg (19 lbs) DVC6205 SIS: 4.1 kg (9 lbs) DVC6215: 1.4 kg (3.1 lbs)</p>
--	---

-continued-

Table 1-1. Specifications (continued)

<p>Construction Materials Housing, module base, and terminal box <i>Standard:</i> A03600 low copper aluminum alloy <i>Optional:</i> Stainless steel Cover: Thermoplastic polyester Elastomers: Fluorosilicone</p> <p>Options ■ Supply and output pressure gauges or tire valves ■ Integral mounted filter regulator ■ Energize to trip ■ Standard Bleed Relay ■ Remote mount⁽⁹⁾⁽¹⁰⁾ ■ LCP100 local control panel ■ Fisher LC340 line conditioner ■ Stainless steel</p>	<p>Declaration of SEP</p> <p>Fisher Controls International LLC declares this product to be in compliance with Article 4 paragraph 3 of the PED Directive 2014/68/EU. It was designed and manufactured in accordance with Sound Engineering Practice (SEP) and cannot bear the CE marking related to PED compliance.</p> <p>However, the product <i>may</i> bear the CE marking to indicate compliance with <i>other</i> applicable European Community Directives.</p>
--	--

NOTE: Specialized instrument terms are defined in ANSI/ISA Standard 51.1 – Process Instrument Terminology.

1. The pressure/temperature limits in this document and any other applicable code or standard should not be exceeded.
2. The electronic output is available with either the position transmitter or the switch.
3. Normal m3/hour – Normal cubic meters per hour at 0°C and 1.01325 bar, absolute. Scfh – Standard cubic feet per hour at 60°F and 14.7 psia.
4. Values at 1.4 bar (20 psig) based on single-acting direct relay; values at 5.5 bar (80 psig) based on double-acting relay.
5. The Quad O steady-state consumption requirement of 6 scfh can be met by a DVC6200 SIS with low bleed relay A option, when used with up to 4.8 bar (70 psi) supply of Natural Gas at 16°C (60°F). The 6 scfh requirement can be met by low bleed relay B and C when used with up to 5.2 bar (75 psi) supply of Natural Gas at 16°C (60°F).
6. Temperature limits vary based on hazardous area approval. Lower temperature limit for CUTR Ex d approval with fluorosilicone elastomers is -53°C (-63.4°F).
7. Not applicable for travels less than 19 mm (0.75 inch) or for shaft rotation less than 60 degrees. Also not applicable for digital valve controllers in long-stroke applications over 4-inch.
8. Rotary actuators with 180 degree rated travel require a special mounting kit; contact your Emerson sales office for kit availability
9. 4-conductor shielded cable, 18 to 22 AWG minimum wire size, in rigid or flexible metal conduit, is required for connection between base unit and feedback unit. Pneumatic tubing between base unit output connection and actuator has been tested to 91 meters (300 feet). At 15 meters (50 feet) there was no performance degradation. At 91 meters there was minimal pneumatic lag.
10. The position monitor (transmitter or switch) with the remote mount construction is not safety certified.

Table 1-2. EMC Summary Results—Immunity

Port	Phenomenon	Basic Standard	Test Level	Performance Criteria ⁽¹⁾
Enclosure	Electrostatic discharge (ESD)	IEC 61000-4-2	4 kV contact 8 kV air	A
	Radiated EM field	IEC 61000-4-3	80 to 1000 MHz @ 10V/m with 1 kHz AM at 80% 1400 to 2000 MHz @ 3V/m with 1 kHz AM at 80% 2000 to 2700 MHz @ 1V/m with 1 kHz AM at 80%	A
	Rated power frequency magnetic field	IEC 61000-4-8	30 A/m at 50/60Hz	A
I/O signal/control	Burst	IEC 61000-4-4	1 kV	A
	Surge	IEC 61000-4-5	1 kV	B
	Conducted RF	IEC 61000-4-6	150 kHz to 80 MHz at 3 Vrms	A

Performance criteria: +/- 1% effect.
 1. A = No degradation during testing. B = Temporary degradation during testing, but is self-recovering.

Related Documents

This section lists other documents containing information related to the DVC6200 SIS digital valve controller. These documents include:

- Bulletin 62.1:DVC6200 SIS FIELDVUE DVC6200 SIS Digital Valve Controller ([D103555X012](#))
- Bulletin 62.1:DVC6200(S1) FIELDVUE DVC6200 Digital Valve Controller Dimensions ([D103543X012](#))
- Bulletin 62.1:Digital Valve Controller - Fisher FIELDVUE Digital Valve Controller Product Selection ([D104363X012](#))
- FIELDVUE DVC6200 Series Quick Start Guide ([D103556X012](#))

- CSA Hazardous Area Approvals - DVC6200 Series Digital Valve Controllers ([D104203X012](#))
- FM Hazardous Area Approvals - DVC6200 Series Digital Valve Controllers ([D104204X012](#))
- ATEX Hazardous Area Approvals - DVC6200 Series Digital Valve Controllers ([D104205X012](#))
- IECEx Hazardous Area Approvals - DVC6200 Series Digital Valve Controllers ([D104206X012](#))
- FIELDVUE DVC6200 SIS Safety Manual ([D103601X012](#))
- HART Field Device Specification for FIELDVUE DVC6200 SIS ([D103638X012](#))
- Monitoring Health of External Solenoid Valve (SOV) with FIELDVUE DVC6200 SIS Digital Valve Controllers ([D104028X012](#))
- Partial Stroke Test using 475/375 Field Communicator ([D103320X012](#))
- Partial Stroke Test using ValveLink Software ([D103641X012](#))
- Pre-Commissioning Installation / Setup Guidelines using ValveLink Software ([D103285X012](#))
- Bulletin 62.1:LCP200 ([D104313X012](#))
- Fisher LCP200 Instruction Manual ([D104296X012](#))
- Bulletin 62.1:LCP100 ([D103604X012](#))
- Fisher LCP100 Instruction Manual ([D103272X012](#))
- Fisher LC340 Instruction Manual ([D102797X012](#))
- Fisher HF340 Filter Instruction Manual ([D102796X012](#))
- AMS Trex Device Communicator [User Guide](#)
- ValveLink Software Help or [Documentation](#)

All documents are available from your [Emerson sales office](#) or at Fisher.com.

Educational Services

For information on available courses for the DVC6200 SIS digital valve controller, as well as a variety of other products, contact:

Emerson Automation Solutions
Educational Services - Registration
Phone: +1-641-754-3771 or +1-800-338-8158
E-mail: education@emerson.com
emerson.com/fishervalvetraining

Section 2 Wiring Practices

Logic Solver or Control System Requirements

There are several parameters that should be checked to ensure the logic solver or control system is compatible with the DVC6200 SIS digital valve controller.

HART Filter / Line Conditioner

Depending on the logic solver or control system and operational mode of the DVC6200 SIS digital valve controller, a line conditioner or HART filter may be required.

Operational Mode	Control System or Logic Solver	HART Filter Required?	Line Conditioner Required?
4-20 mA Point-to-Point Loop	PROVOX™, RS3™, DeltaV™, Ovation™	No	No
	All Others	Consult Sales Office	No
24 VDC Multi-Drop Loop	All	No	Yes

The HF340 HART filter and LC340 Line Conditioner are passive devices that are inserted in the field wiring of the HART loop. A filter or line conditioner is normally installed near the field wiring terminals of the system I/O (see figure 2-1). Its purpose is to effectively isolate the system output from modulated HART communication signals and raise the impedance of the system to allow HART communication. For more information, refer to the HF340 HART filter ([D102796X012](#)) or LC340 Line Conditioner ([D102797X012](#)) instruction manual.

Voltage Available

The voltage available at the DVC6200 SIS digital valve controller must be at least 10 VDC. The voltage available at the instrument is not the actual voltage measured at the instrument when the instrument is connected. The voltage measured at the instrument is limited by the instrument and is typically less than the voltage available.

As shown in figure 2-1, the voltage available at the instrument depends upon:

- The logic solver or control system compliance voltage
- if a line conditioner filter or intrinsic safety barrier is used, and
- the wire type and length.

The compliance voltage is the maximum voltage at the logic solver or control system output terminals at which the system can produce maximum loop current.

The voltage available at the instrument may be calculated from the following equation:

Voltage Available = [Compliance Voltage (at maximum current)] - [line conditioner/filter voltage drop] - [total cable resistance × maximum current] - [barrier resistance x maximum current].

The calculated voltage available should be greater than or equal to 10 volts DC.

Figure 2-1. Determining Voltage Available at the Instrument

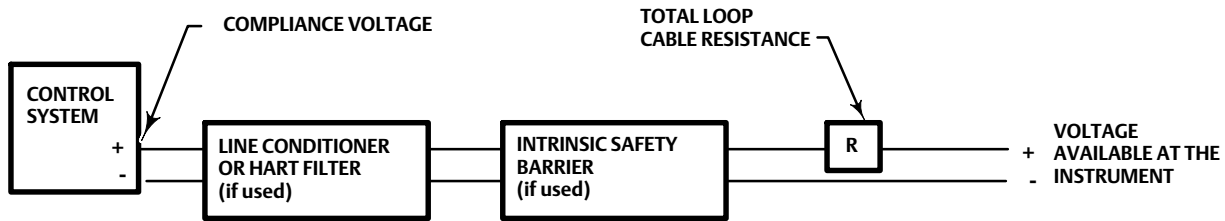

Calculate Voltage Available at the Instrument as follows:

Logic solver or control system compliance voltage

- Line conditioner or filter voltage drop (if used) 1

- Intrinsic safety barrier resistance (if used) x maximum loop current

- Total loop cable resistance x maximum loop current

= Voltage available at the instrument 2

Example Calculation

18.5 volts (at 21.05 mA for Honeywell TDC2000)

- 2 volts

- 2.55 volts (121 ohms x 0.02105 amps)

- 1.01 volts (48 ohms x 0.02105 amps for 1000 feet of Belden 9501 cable)

= 15.49 volts, available—if safety barrier (2.55 volts) is not used

NOTES:

1 Obtain filter voltage drop. The measured drop will be different than this value. The measured filter voltage drop depends upon control system output voltage, the intrinsic safety barrier (if used), and the instrument. See note 2.

2 The voltage available at the instrument is not the voltage measured at the instrument terminals. Once the instrument is connected, the instrument limits the measured voltage to approximately 8.0 to 9.5 volts.

Compliance Voltage

If the compliance voltage of the logic solver or control system is not known, perform the following compliance voltage test.

1. Disconnect the field wiring from the system and connect equipment as shown in figure 2-2 to the system terminals.

Figure 2-2. Voltage Test Schematic

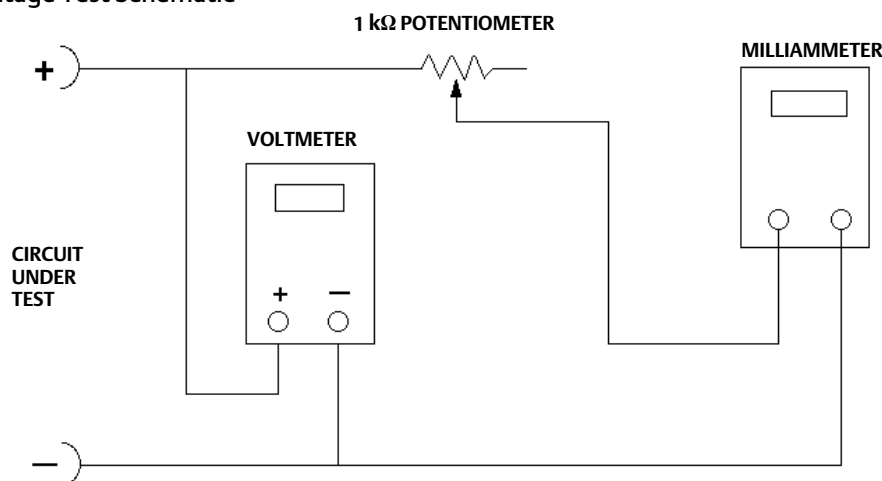

A6192-1

2. Set the system to provide maximum output current.
3. Increase the resistance of the 1 kΩ potentiometer, shown in figure 2-2, until the current observed on the milliammeter begins to drop quickly.
4. Record the voltage shown on the voltmeter. This is the compliance voltage.

Contact your [Emerson sales office](#) for specific parameter information relating to your control system.

Maximum Cable Capacitance

The maximum cable length for HART communication is limited by the characteristic capacitance of the cable. Maximum length due to capacitance can be calculated using the following formulas:

$$\text{Length(ft)} = [160,000 - C_{\text{master}}(\text{pF})] \div [C_{\text{cable}}(\text{pF/ft})]$$

$$\text{Length(m)} = [160,000 - C_{\text{master}}(\text{pF})] \div [C_{\text{cable}}(\text{pF/m})]$$

where:

160,000 = a constant derived for FIELDVUE instruments to ensure that the HART network RC time constant will be no greater than 65 μs (per the HART specification).

C_{master} = the capacitance of the control system or HART filter

C_{cable} = the capacitance of the cable used (see table 2-1)

The following example shows how to calculate the cable length for a Foxboro™ I/A control system (1988) with a C_{master} of 50,000 pF and a Belden 9501 cable with characteristic capacitance of 50pF/ft.

$$\text{Length(ft)} = [160,000 - 50,000\text{pF}] \div [50\text{pF/ft}]$$

$$\text{Length} = 2200 \text{ ft.}$$

The HART communication cable length is limited by the cable characteristic capacitance. To increase cable length, select a wire with lower capacitance per foot. Contact your Emerson sales office for specific information relating to your control system.

Table 2-1. Cable Characteristics

Cable Type	Capacitance ⁽¹⁾ pF/Ft	Capacitance ⁽¹⁾ pF/m	Resistance ⁽²⁾ Ohms/ft	Resistance ⁽²⁾ Ohms/m
BS5308/1, 0.5 sq mm	61.0	200	0.022	0.074
BS5308/1, 1.0 sq mm	61.0	200	0.012	0.037
BS5308/1, 1.5 sq mm	61.0	200	0.008	0.025
BS5308/2, 0.5 sq mm	121.9	400	0.022	0.074
BS5308/2, 0.75 sq mm	121.9	400	0.016	0.053
BS5308/2, 1.5 sq mm	121.9	400	0.008	0.025
BELDEN 8303, 22 awg	63.0	206.7	0.030	0.098
BELDEN 8441, 22 awg	83.2	273	0.030	0.098
BELDEN 8767, 22 awg	76.8	252	0.030	0.098
BELDEN 8777, 22 awg	54.9	180	0.030	0.098
BELDEN 9501, 24 awg	50.0	164	0.048	0.157
BELDEN 9680, 24 awg	27.5	90.2	0.048	0.157
BELDEN 9729, 24 awg	22.1	72.5	0.048	0.157
BELDEN 9773, 18 awg	54.9	180	0.012	0.042
BELDEN 9829, 24 awg	27.1	88.9	0.048	0.157
BELDEN 9873, 20 awg	54.9	180	0.020	0.069

1. The capacitance values represent capacitance from one conductor to all other conductors and shield. This is the appropriate value to use in the cable length calculations.
 2. The resistance values include both wires of the twisted pair.

Auxiliary Terminal Wiring Length Guidelines

The Auxiliary Input Terminals of a DVC6200 SIS can be used with an LCP100 local control panel or a locally-mounted switch for initiating a partial stroke test. Some applications require that the switch or local control panel be installed remotely from the DVC6200 SIS.

The length for wiring connected to the Auxiliary Input Terminals is limited by capacitance. For proper operation of the Auxiliary Input Terminals capacitance should not exceed 100,000 pF. As with all control signal wiring, good wiring practices should be observed to minimize adverse effect of electrical noise on the Aux Switch function.

Example Calculation: Capacitance per foot or per meter is required to calculate the length of wire that may be connected to the Aux switch input. The wire should not exceed the capacitance limit of 100,000 pF. Typically the wire manufacturer supplies a data sheet which provides all of the electrical properties of the wire. The pertinent parameter is the highest possible capacitance. If shielded wire is used, the appropriate number is the “Conductor to Other Conductor & Shield” value.

Example — 18AWG Unshielded Audio, Control and Instrumentation Cable

Manufacturer's specifications include:

Nom. Capacitance Conductor to Conductor @ 1 KHz: 26 pF/ft
Nom. Conductor DC Resistance @ 20 Deg. C: 5.96 Ohms/1000 ft
Max. Operating Voltage - UL 200 V RMS (PLTC, CMG), 150 V RMS (ITC)
Allowable Length with this cable = $100,000\text{pF} / (26\text{pF/ft}) = 3846 \text{ ft}$

Example — 18AWG Shielded Audio, Control and Instrumentation Cable

Manufacturer's specifications include:

Nom. Characteristic Impedance: 29 Ohms
Nom. Inductance: .15 $\mu\text{H/ft}$
Nom. Capacitance Conductor to Conductor @ 1 KHz: 51 pF/ft
Nom. Cap. Cond. to other Cond. & Shield @ 1 KHz 97 pF/ft
Allowable Length with this cable = $100,000\text{pF} / (97\text{pF/ft}) = 1030 \text{ ft}$

The AUX switch input passes less than 1 mA through the switch contacts, and uses less than 5 V, therefore, neither the resistance nor the voltage rating of the cable are critical. Ensure that switch contact corrosion is prevented. It is generally advisable that the switch have gold-plated or sealed contacts.

Local Control Panel

Fisher LCP100 and LCP200 local control panels are used to manually open and close a safety shutdown valve.

The LCP100 provides a manual reset feature as well as a button for initiating a partial stroke test.

The LCP200 can be configured to auto or manual reset after a trip. It also offers a smart auto reset configuration which requires a manual reset for locally initiated trips but auto reset for all other trips. It includes trip and reset push buttons to provide a corresponding change in the state of the associated single pole double throw (SPDT) relay. The trip and reset relays can be used as input to initiate Trip or Reset action in the logic solver. Additionally, it includes a button for initiating a partial stroke test.

Installation

Both LCP100 and LCP200 local control panels have mounting holes for on-site mounting of the device.

Notes

A mounting kit is available to use when replacing an LCP100 with the LCP200. Contact your [Emerson sales office](#) for information on obtaining this kit.

The local control panel must be installed so that the wiring connections are on the bottom to prevent accumulation of moisture inside the box.

LCP100: When installing the LCP100 cover tighten the screws evenly in a criss-cross pattern to a torque of 2.8 N•m (25 lbf•in) to help ensure the cover is properly installed.

LCP200: When installing the terminal cover on the LCP200, use a 4 mm hex key to tighten the screws evenly in a criss-cross pattern to a torque of 8.7 N•m (77 lbf•in) +/- 10%, to help ensure the cover is properly installed. Apply silicone lubricant to the terminal box O-ring.

Electrical Connections

⚠ WARNING

Select wiring and/or cable glands that are rated for the environment of use (such as hazardous location, ingress protection, and temperature). Failure to use properly rated wiring and/or cable glands can result in personal injury or property damage from fire or explosion.

Wiring connections must be in accordance with local, regional, and national codes for any given hazardous area approval. Failure to follow the local, regional, and national codes could result in personal injury or property damage from fire or explosion.

LCP100 protection and wiring methods are defined in table 2-2. Refer to the LCP100 instruction manual ([D103272X012](#)) for installation wiring diagrams, as well as all other information on the LCP100 local control panel.

Wiring configurations for the LCP200, based on installation requirements, are defined in table 2-3. Refer to the LCP200 instruction manual ([D104296X012](#)) for installation wiring diagrams, as well as all other information on the LCP200 local control panel.

Documents are available from your Emerson sales office or at [Fisher.com](#).

Table 2-2. Fisher LCP100 Protection and Wiring Methods

LCP100 Protection Method	LCP100 Power Source	Wiring Order from Logic Solver	DVC6200 SIS Mode (Current or Voltage)
Ex e mb [ib] IIC Ex tb IIIC	LOOP	DVC6200 SIS then LCP100	Point-to-Point
			Multi-Drop
		LCP100 then DVC6200 SIS	Point-to-Point
			Multi-Drop
	24 VDC	DVC6200 SIS then LCP100	Point-to-Point
			Multi-Drop
Ex ic IIC Ex tb IIIC	LOOP	DVC6200 SIS then LCP100	Point-to-Point
			Multi-Drop
		LCP100 then DVC6200 SIS	Point-to-Point
			Multi-Drop
	24 VDC	DVC6200 SIS then LCP100	Point-to-Point
			Multi-Drop
Ex ia IIB Ex tb IIIC	LOOP	DVC6200 SIS then LCP100	Point-to-Point
			Multi-Drop
		LCP100 then DVC6200 SIS	Point-to-Point
			Multi-Drop

Table 2-3. Fisher LCP200 Wiring Configurations

LCP200 Power Source	System Output	DVC6200 SIS Mode (Current or Voltage)
LOOP	8-20 mA	Point-to-Point
	24 VDC	Multi-Drop
24 VDC External Power	4-20 mA	Point-to-Point
	24 VDC	Multi-Drop

Note

Factory default for the DIP switch power selector is 24VDC.

Section 3 Configuration

Note

Fast-key sequences are only applicable to the 475 Field Communicator. They do not apply to the Trex Device Communicator.

Guided Setup

Device Communicator	Configure > Guided Setup (2-1)
---------------------	--------------------------------

To quickly setup the instrument, the following procedures will guide you through the process.

Device Setup is used to configure the unique parameters for the valve, actuator, instrument and accessory construction. After Device Setup is complete, proceed with Auto Calibration.

Auto Calibration is used to establish the limits of physical travel. During this process, the valve will fully stroke from one travel extreme to the other. There are three calibration options to choose from:

- **Autocalibrate – Standard** runs the full calibration process (recommended).
- **Autocalibrate – Without Biases** establishes the travel end points, but does not adjust the Minor Loop Feedback bias. This is for advanced use when manually setting the biases for large actuators.
- **Advanced Settings** allows additional custom configuration of calibration parameters. This is for advanced use when calibrating large actuators.

Manual Setup

Manual Setup allows you to configure the digital valve controller to your application. Table 3-1 lists the default settings for a standard factory configuration. You can adjust actuator response, set the various modes, alerts, ranges, travel cutoffs and limits. You can also restart the instrument and set the protection.

Table 3-1. Default Detailed Setup Parameters

	Setup Parameter	Default Setting ⁽¹⁾
Instrument Configuration	Restart Control Mode	Resume Last
	Polling Address	0
	Burst Mode Enable	No
	Burst Command	3
Dynamic Response and Tuning	Input Characterization	Linear
	Travel Limit High	125%
	Travel Limit Low	-25%
	Travel/Pressure Cutoff High	50%
	Travel/Pressure Cutoff Low	50%
	Integrator Enable	Yes
	Integral Gain	9.4 repeats/minute
Deviation & Other Alerts	Integral Deadzone	0.26%
	Travel Deviation Alert Enable	Yes
	Travel Deviation Alert Point	5%
	Travel Deviation Time	9.99 sec
	Pressure Deviation Alert Enable	Yes
	Pressure Deviation Alert Point	5 psi ⁽²⁾
	Pressure Deviation Alert Time	9.99 sec
	Drive Signal Alert Enable	Yes
Supply Pressure Alert Enable	Yes	

1. The settings listed are for standard factory configuration. DVC6200 SIS instruments can also be ordered with custom configuration settings. Refer to the order requisition for custom settings.
2. Adjust to bar, kPa, or Kg/cm² if necessary.

Refer to table 3-2 for possible configurations for a digital valve controller operated by a 4-20 mA input current (point-to-point mode), and table 3-3 for possible configurations for a digital valve controller operated by a 0-24 VDC power supply (multi-drop mode).

Table 3-2. Possible Configurations for a FIELDVUE DVC6200 SIS Digital Valve Controller operated by 4-20 mA-

Device Setup Configuration			Operating Conditions		Status Monitoring	
Relay Type	Partial Stroke Start Point	Zero Power Condition	Input Current	Actual Valve Travel	Travel Set Point	Travel
A or C	Open	Close	Common Application			
			20 mA	Open	100%	100%
		Open ⁽¹⁾	Less Common Application			
	Close	Close ⁽¹⁾	Less Common Application			
			4 mA	Open	100%	100%
		Open	Common Application			
B	Open	Close ⁽¹⁾	Less Common Application			
			20 mA	Open	100%	100%
		Open	Common Application			
	Close	Close	Common Application			
			4 mA	Close	0%	0%
		Open ⁽¹⁾	Less Common Application			
			20 mA	Close	0%	0%

1. These configurations are not available when the Hardware Shutdown Switch is Enabled.

Note

DVC6200 SIS instruments in PT-PT mode require the Hardware Shutdown Switch be Enabled for FMEDA failure rates to be valid during 4-20 mA operation.

Table 3-3. Possible Configurations for a FIELDVUE DVC6200 SIS Digital Valve Controller operated by 0-24 VDC

Device Setup Configuration			Operating Conditions		Status Monitoring	
Relay Type	Partial Stroke Start Point	Zero Power Condition	Power Supply	Actual Valve Travel	Travel Set Point	Travel
A or C	Open	Close	Common Application			
			24 VDC	Open	100%	100%
		Open ⁽¹⁾	Less Common Application			
	Close	Close ⁽¹⁾	Less Common Application			
			24 VDC	Close	0%	0%
		Open	Common Application			
B	Open	Close	Less Common Application			
			24 VDC	Open	100%	100%
		Open ⁽¹⁾	Common Application			
	Close	Close ⁽¹⁾	Common Application			
			24 VDC	Close	0%	0%
		Open	Less Common Application			
			24 VDC	Close	0%	0%

1. In these configurations, the DVC6200 SIS is used as a diagnostic device, the safety function is provided by other devices in the pneumatic loop, e.g. a solenoid valve.

Mode and Protection

Device Communicator	Configure > Manual Setup > Mode and Protection (2-2-1)
---------------------	--

Instrument Mode

There are two instrument modes for the DVC6200 SIS; In Service or Out of Service. In Service is the normal operating mode such that the instrument follows the 4-20 mA or 24 VDC control signal. Out of Service is required in some cases to modify configuration parameters or to run diagnostics.

Note

Some changes that require the instrument to be taken Out Of Service will not take effect until the instrument is placed back In Service or the instrument is restarted.

Write Protection

There are two Write Protection modes for the DVC6200 SIS: Not Protected or Protected. Protected prevents configuration and calibration changes to the instrument. The default setting is Not Protected. Write Protection can be changed to Protected remotely. However, to change Write Protection to Not Protected, you must have physical access to the instrument. The procedure will require you to press a button (🔒) on the terminal box as a security measure.

Instrument

Device Communicator	Configure > Manual Setup > Instrument (2-2-2)
---------------------	---

Follow the prompts on the Device Communicator display to configure the following Instrument parameters:

Identification

- **HART Tag**—A tag name up to 8 characters is available for the instrument. The HART tag is the easiest way to distinguish between instruments in a multi-instrument environment. Use the HART tag to label instruments electronically according to the requirements of your application. The tag you assign is automatically displayed when the Device Communicator establishes contact with the digital valve controller at power-up.
- **HART Long Tag (HART Universal Revision 7 only)**—A tag name up to 32 characters is available for the instrument.
- **Description** provides a separate electronic label allowing for additional instrument identification.
- **Message**—Enter any message with up to 32 characters. Message provides the most specific user-defined means for identifying individual instruments in multi-instrument environments.
- **Polling Address**—If the digital valve controller is used in point-to-point operation, the Polling Address is 0. When several devices are connected in the same loop, such as for split ranging, each device must be assigned a unique polling address. The Polling Address is set to a value between 0 and 63 for HART 7 and 0 and 15 for HART 5. To change the polling address the instrument must be Out Of Service. For the Device Communicator to be able to communicate with a device whose polling address is not 0, it must be configured to automatically search for all or specific connected devices.

Serial Numbers

- **Instrument Serial Number**—Enter the serial number on the instrument nameplate, up to 12 characters.
- **Valve Serial Number**—Enter the serial number for the valve in the application with up to 12 characters.

Units

- **Pressure Units**—Defines the output and supply pressure units in either psi, bar, kPa, or kg/cm².
- **Temperature Units**—Degrees Fahrenheit or Celsius. The temperature measured is from a sensor mounted on the digital valve controller's printed wiring board.
- **Analog Input Units**—Permits defining the Analog Input Units in mA or percent of 4-20 mA range.

Terminal Box

- **Calibration (CAL) Button**—This button is near the wiring terminals in the terminal box and provides a quick means to autocalibrate the instrument. The button must be pressed for 3 to 10 seconds. Autocalibration will move the valve through the full range of travel whether the Instrument Mode is In Service or Out of Service. However, if the Write Protection is Protected, this button will not be active. To abort, press the button again for 1 second. The calibration button is disabled by default.
- **Auxiliary Terminal Action**—These wire terminals can be configured to initiate a partial stroke test upon detection of a short across the (+) and (-) terminals. The terminals must be shorted for 3 to 10 seconds. Alternatively, the auxiliary terminals can be configured to support the local control panel.

Spec Sheet

The Spec Sheet provides a means to store the entire control valve specifications on board the DVC6200 SIS.

Edit Instrument Time

Permits setting the instrument clock. When alerts are stored in the alert record, the record includes the time and date. The instrument clock uses a 24-hour format.

Travel/Pressure Control

Device Communicator | Configure > Manual Setup > Travel/Pressure Control (2-2-3)

End Point Pressure Control (EPPC)

- **EPPC Enable**—Select Yes or No. End Point Pressure Control allows the digital valve controller to pull back from saturation of the pneumatic output after reaching the travel extreme. Rather than having the instrument provide full supply pressure (saturation) continuously at the travel extreme, the digital valve controller switches to an End Point Pressure Control where the output pressure (pressure controller set point) to the actuator is maintained at the EPPC Set Point. Because the digital valve controller is constantly in control and not allowed to reach a dormant or saturated state, it is constantly testing its own pneumatic system. If there is an output pressure deviation, for example, the instrument will issue an alert. To ensure there is an alert when an output pressure deviation occurs, setup the alert as described under Pressure Deviation Alert.
- **EPPC Set Point**—Used in conjunction with End Point Pressure Control, End Point Pressure Control Set Point allows the user to select a pressure to be delivered by the instrument at the travel extreme. For a fail-closed valve, this pressure must be sufficient to maintain the fully open position. For a fail-open valve, this pressure (which is automatically set to supply pressure) must be sufficient to fully close the valve and maintain its rated shutoff classification. For double-acting spring return actuators, this is the differential pressure required to either maintain the fully open or fully closed position, depending on the valve and actuator configuration. For a double-acting actuator without springs with a fail-close valve, this is 95% of the supply pressure.
- **EPPC Saturation Time**—End Point Pressure Control Saturation Time is the time the digital valve controller stays in hard cutoff before switching to pressure control. Default is 45 seconds.
- **End Point Pressure Control Tuning**—These are the tuning parameters that the instrument uses while in end point pressure control. The tuning set letters correspond with the travel control tuning sets (e.g. if tuning set C is appropriate for travel control, it is also appropriate for pressure control). However, note that the individual values may be different between travel and pressure control.

Characterization

Input Characterization defines the relationship between the travel target and ranged set point. Ranged set point is the input to the characterization function. If the zero power condition equals closed, then a set point of 0% corresponds to a ranged input of 0%. If the zero power condition equals open, a set point of 0% corresponds to a ranged input of 100%. Travel target is the output from the characterization function.

To select an input characterization, select *Input Characterization* from the *Characterization* menu. You can select from the three fixed input characteristics shown in figure 3-1 or you can select a custom characteristic. Figure 3-1 shows the relationship between the travel target and ranged set point for the fixed input characteristics, assuming the Zero Power Condition is configured as closed.

You can specify 21 points on a custom characteristic curve. Each point defines a travel target, in % of ranged travel, for a corresponding set point, in % of ranged set point. Set point values range from -6.25% to 106.25%. Before modification, the custom characteristic is linear.

Custom Characterization

To define a custom input character, from the *Characterization* menu select *Custom Characterization*. Select the point you wish to define (1 to 21), then enter the desired set point value. Press Enter then enter the desired travel target for the corresponding set point. When finished, select point 0 to return to the *Characterization* menu.

With input characterization you can modify the overall characteristic of the valve and instrument combination. Selecting an equal percentage, quick opening, or custom (other than the default of linear) input characteristic modifies the overall valve and instrument characteristic. However, if you select the linear input characteristic, the overall valve and instrument characteristic is the characteristic of the valve, which is determined by the valve trim (i.e., the plug or cage).

Figure 3-1. Travel Target Versus Ranged Set Point, for Various Input Characteristics (Zero Power Condition = Closed)

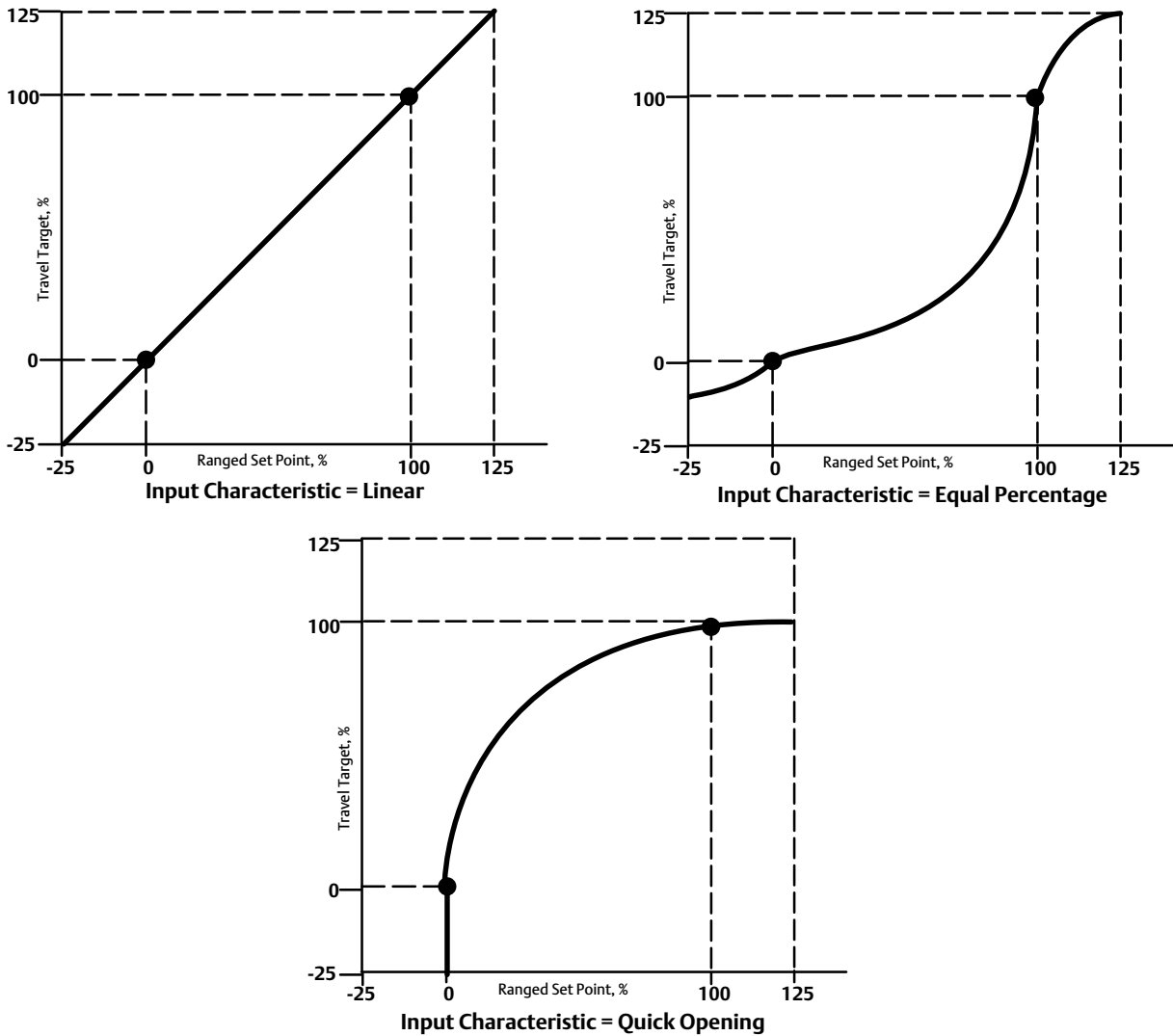

A6535-1

Dynamic Response

- **SP Rate Open** is the maximum rate (% of valve travel per second) at which the digital valve controller will move to the open position regardless of the rate of input current change. A value of 0 will deactivate this feature and allow the valve to stroke open as fast as possible.
- **SP Rate Close** is the maximum rate (% of valve travel per second) at which the digital valve controller will move to the close position regardless of the rate of input current change. A value of 0 will deactivate this feature and allow the valve to stroke close as fast as possible.

- **Set Point Filter Time (Lag Time)** slows the response of the digital valve controller. A value ranging from 0.2 to 10.0 can be used for noisy or fast processes to improve closed loop process control. Entering a value of 0.0 will deactivate the lag filter.

Travel Cutoffs

- **Hi Cutoff Select**—When selected the Travel Target is set to 123% when the Travel exceeds the Hi Cutoff Point.
- **Hi Cutoff Point** is the point within the calibrated travel range above which the cutoff is in effect. When using cutoffs, a Cutoff Hi of 50% is recommended to ensure valve goes fully open.
- **Lo Cutoff Select**—When selected the Travel Target is set to -23% when the Travel is below the Lo Cutoff Point.
- **Lo Cutoff Point** is the point within the calibrated travel range below which the cutoff is in effect. When using cutoffs, a Cutoff Lo of 50% is recommended to help ensure maximum shutoff seat loading.

Tuning

Device Communicator	Configure > Manual Setup > Tuning (2-2-4)
---------------------	---

Travel Tuning

⚠ WARNING

Changes to the tuning set may cause the valve/actuator assembly to stroke. To avoid personal injury and property damage caused by moving parts, keep hands, tools, and other objects away from the valve/actuator assembly.

- **Travel Tuning Set**

There are eleven tuning sets to choose from. Each tuning set provides a preselected value for the digital valve controller gain settings. Tuning set C provides the slowest response and M provides the fastest response.

Table 3-4 lists the proportional gain, velocity gain and minor loop feedback gain values for preselected tuning sets.

Table 3-4. Gain Values for Preselected Travel Tuning Sets

Tuning Set	Proportional Gain	Velocity Gain	Minor Loop Feedback Gain
C	4.4	3.0	35
D	4.8	3.0	35
E	5.5	3.0	35
F	6.2	3.1	35
G	7.2	3.6	34
H	8.4	4.2	31
I	9.7	4.85	27
J	11.3	5.65	23
K	13.1	6.0	18
L	15.5	6.0	12
M	18.0	6.0	12
X (Expert)	User Adjusted	User Adjusted	User Adjusted

In addition, you can specify Expert tuning and individually set the proportional gain, velocity gain, and minor loop feedback gain. Individually setting or changing any tuning parameter or running Stabilize/Optimize will automatically change the tuning set to X (expert).

Note

Use Expert tuning only if standard tuning has not achieved the desired results.

Stabilize/Optimize, or Performance Tuner in ValveLink software, may be used to achieve the desired results more rapidly than manual Expert tuning.

Table 3-5 provides tuning set selection guidelines for Fisher and Baumann actuators. These tuning sets are only recommended starting points. After you finish setting up and calibrating the instrument, you may have to select either a higher or lower tuning set to get the desired response.

- **Proportional Gain** for the travel control tuning set. Changing this parameter will also change the tuning set to Expert.
- **Velocity Gain** for the travel control tuning set. Changing this parameter will also change the tuning set to Expert.
- **MLFB Gain** is the minor loop feedback gain for the travel control tuning set. Changing this parameter will also change the tuning set to Expert.
- **Integral Enable**—Yes or No. Enable the integral setting to improve static performance by correcting for error that exists between the travel target and actual travel. Travel Integral Control is enabled by default.
- **Integral Gain**—Travel Integral Gain is the ratio of the change in output to the change in input, based on the control action in which the output is proportional to the time integral of the input.
- **Stabilize/Optimize**

⚠ WARNING

During Stabilize/Optimize the valve may move, causing process fluid or pressure to be released. To avoid personal injury and property damage caused by the release of process fluid or pressure, isolate the valve from the process and equalize pressure on both sides of the valve or bleed off the process fluid.

Stabilize/Optimize permits you to adjust valve response by changing the digital valve controller tuning. During this routine, the instrument must be out of service; however, the instrument will respond to setpoint changes.

If the valve is unstable, select *Decrease Response* to stabilize valve operation. This selects the next lower tuning set (e.g., F to E). If the valve response is sluggish, select *Increase Response* to make the valve more responsive. This selects the next higher tuning set (e.g., F to G).

If after selecting *Decrease Response* or *Increase Response* the valve travel overshoot is excessive, select *Decrease Damping* to select a damping value that allows more overshoot. Select *Increase Damping* to select a damping value that will decrease the overshoot. When finished, select *done*.

Table 3-5. Actuator Information for Initial Setup

Actuator Manufacturer	Actuator Model	Actuator Size	Actuator Style	Starting Tuning Set	Travel Sensor Motion ⁽²⁾ Relay A or C ⁽³⁾		
Fisher	585C & 585CR	25 50 60 68, 80 100, 130	Piston Dbl w/ or w/o Spring. See actuator instruction manual and nameplate.	E I J L M	User Specified		
	657	30, 30i 34, 34i, 40, 40i 45, 45i, 50, 50i 46, 46i, 60, 60i, 70, 70i & 80-100	Spring & Diaphragm	H K L M	Away from the top of the instrument		
	667	30, 30i 34, 34i, 40, 40i 45, 45i, 50, 50i 46, 46i, 60, 60i, 70, 70i, 76, 76i & 80-100	Spring & Diaphragm	H K L M	Towards the top of the instrument		
	1051 & 1052	20, 30 33 40 60, 70	Spring & Diaphragm (Window-mount)	H I K M	Away from the top of the instrument		
	1061	30 40 60 68, 80, 100, 130	Piston Dbl w/o Spring	J K L M	Depends upon pneumatic connections. See description for Travel Sensor Motion		
	1066SR		20 27, 75	Piston Sgl w/Spring	G L	Mounting Style	Travel Sensor Motion
						A	Away from the top of the instrument
						B	Towards the top of the instrument
						C	Towards the top of the instrument
	D	Away from the top of the instrument					
	2052	1 2 3	Spring & Diaphragm (Window-mount)	H J M	Away from the top of the instrument		
	3024C	30, 30E 34, 34E, 40, 40E 45, 45E	Spring & Diaphragm	E H K	For P ₀ operating mode (air opens): Towards the top of the instrument For P _s operating mode (air closes): Away from the top of the instrument		
	GX	225	Spring & Diaphragm	X ⁽¹⁾	Air to Open Towards the top of the instrument	Air to Close Away from the top of the instrument	
750		K					
1200		M					
Baumann	Air to Extend	16	Spring & Diaphragm	C	Away from the top of the instrument		
	Air to Retract	32		E	Towards the top of the instrument		
		54		H			
	Rotary	10 25 54		E H J	Specify		

NOTE: Refer to figure table 3-6 for feedback connection (magnet assembly) information.
 1. X = Expert Tuning. Proportional Gain = 4.2; Velocity Gain = 3.0; Minor Loop Feedback Gain = 18.0
 2. Travel Sensor Motion in this instance refers to the motion of the magnet assembly.
 3. Values shown are for Relay A and C. Reverse for Relay B.

Integral Settings

- **Integral Dead Zone**—A window around the Primary Setpoint in which integral action is disabled. This feature is used to eliminate friction induced limit cycles around the Primary Setpoint when the integrator is active. The Dead Zone is configurable from 0% to 2%, corresponding to a symmetric window from 0% to +/-2% around the Primary Setpoint. Default value is 0.25%.
- **Integrator Limit**—The Integrator Limit provides an upper limit to the integrator output. The high limit is configurable from 0 to 100% of the I/P drive signal.

Valve and Actuator

Device Communicator	Configure > Manual Setup > Valve and Actuator (2-2-5)
---------------------	---

Valve Style—Enter the valve style, rotary or sliding-stem

Actuator Style—Enter the actuator style, spring and diaphragm, piston double-acting without spring, piston single-acting with spring, or piston double-acting with spring.

Feedback Connection—Refer to table 3-6 for Feedback Connection options. Choose the assembly that matches the actuator travel range.

Note

As a general rule, do not use less than 60% of the magnet assembly travel range for full travel measurement. Performance will decrease as the assembly is increasingly subranged.

The linear magnet assemblies have a valid travel range indicated by arrows molded into the piece. This means that the hall sensor (on the back of the DVC6200 SIS housing) has to remain within this range throughout the entire valve travel. The linear magnet assemblies are symmetrical. Either end may be up.

Table 3-6. Feedback Connection Options

Magnet Assembly	Travel Range		
	mm	Inch	Degrees
SStem #7	4.2-7	0.17-0.28	-
SStem #19	8-19	0.32-0.75	-
SStem #25	20-25	0.76-1.00	-
SStem #38	26-38	1.01-1.50	-
SStem #50	39-50	1.51-2.00	-
SStem #110	51-110	2.01-4.125	-
SStem #210	110-210	4.125-8.25	-
SStem #1 Roller	> 210	> 8.25	60-90°
RShaft Window #1	-	-	60-90°
RShaft Window #2	-	-	60-90°
RShaft End Mount	-	-	60-90°

Relay Type—There are three categories of relays that result in combinations from which to select.

Relay Type: The relay type is printed on the label affixed to the relay body.

A = double-acting or single-acting

B = single-acting, reverse

C = single-acting, direct

Special App: This is used in single-acting applications where the “unused” output port is configured to read the pressure downstream of a solenoid valve.

Lo Bleed: The label affixed to the relay body indicates whether it is a low bleed version.

Zero Power Condition—The position of the valve (open or closed) when the electrical power to the instrument is removed. Zero Power Condition (ZPC) is determined by relay type, as shown in figure 3-2.

Figure 3-2. Zero Power Condition



X077-SIS

Relay Type	Loss of Electrical Power
Single-Acting Direct (Relay A or C)	Port A pressure to zero.
Double-Acting (Relay A)	Port A pressure to zero. Port B pressure to full supply.
Single-Acting Reverse (Relay B)	Port B pressure to full supply.

Travel Sensor Motion

⚠ WARNING

If you answer YES to the prompt for permission to move the valve when determining travel sensor motion, the instrument will move the valve through a significant portion of its travel range. To avoid personal injury and property damage caused by the release of process fluid or pressure, isolate the valve from the process and equalize pressure on both sides of the valve or bleed off the process fluid.

Select Clockwise/Toward Bottom, or Counterclockwise/Toward Top. Travel Sensor Motion establishes the proper travel sensor rotation. For quarter-turn actuators determine rotation by viewing the rotation of the magnet assembly from the back of the instrument.

Note

Travel Sensor Motion in this instance refers to the motion of the magnet assembly. Note that the magnet assembly may be referred to as a magnetic array in user interface tools.

- For instruments with Relay A and C: If increasing air pressure at output A causes the magnet assembly to move down or the rotary shaft to turn clockwise, enter CW/To Bottom Inst. If it causes the magnet assembly to move up, or the rotary shaft to turn counterclockwise, enter CCW/To Top Inst.

- **For instruments with Relay B:** If decreasing air pressure at output B causes the magnet assembly to down, or the rotary shaft to turn clockwise, enter CW/To Bottom Inst. If it causes the magnet assembly to move up, or the rotary shaft to turn counterclockwise, enter CCW/To Top Inst.

Maximum Supply Pressure

Enter the maximum supply pressure that is required to fully stroke the valve.

Port A Pressure Limit

In single acting direct only applications, the instrument will limit the output pressure to the actuator from Port A. When this pressure limit is exceeded the device will go to the no air state.

CAUTION

This is a firmware controlled feature that requires loop power to the instrument. If loop power is lost, or there is an electronic or firmware failure, the protection feature will not remain in effect.

Output Pressure Limit Enable enables/disables the Port A Pressure Limit feature.

Note

There is an associated alert available with this feature. See the Port A Overpressurized alert in the Alert Setup section.

SIS/Partial Stroke Test

Device Communicator | Configure > Manual Setup > SIS/Partial Stroke (2-2-6)

A partial stroke test is the process of taking the valve from the normal end to a target position at a preconfigured ramp rate before returning to the normal end while gathering data. The data is analyzed to evaluate the condition of the valve assembly against a set of user defined thresholds. A partial stroke test is only run if everything is normal in the instrument. A safety demand signal will always take precedence over a partial stroke test.

Partial Stroke Test Parameters

Test Start Point defines the normal (not tripped) end of valve travel. The valve must be at this end for a PST to be initiated. Setting this value to Not Configured will disable partial stroke tests.

Travel Hi Hi defines, in percent (%) of calibrated travel, the point above which the valve is considered to have reached the high end.

Travel Lo Lo defines, in percent (%) of calibrated travel, the point below which the valve is considered to have reached the low end.

Pause Time is the time between the outgoing and incoming strokes of the test. The default value is 5 seconds. Pause Time will not be used if Short Duration PST is enabled. The outgoing stroke is from the normal end to the PST target and the incoming stroke is the return stroke to normal. See figure 3-3.

Figure 3-3. Valve Signature Representation

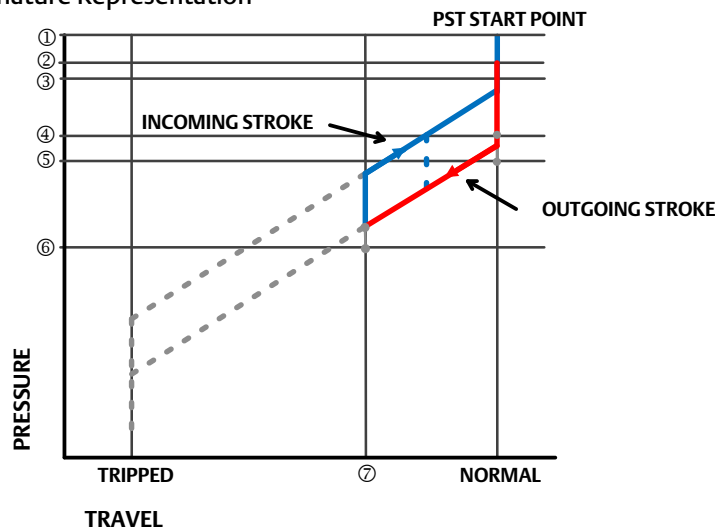

- ① SUPPLY PRESSURE
- ② END POINT PRESSURE CONTROL
- ③ INCOMING PRESSURE THRESHOLD
- ④ LOW FRICTION BREAKOUT PRESSURE THRESHOLD
- ⑤ HIGH FRICTION BREAKOUT PRESSURE THRESHOLD
- ⑥ OUTGOING PRESSURE THRESHOLD
- ⑦ TARGET TRAVEL MOVEMENT $\leq 30\%$

High Friction Breakout Pressure indicates that the breakout required a higher force than configured by the user. Refer to figure 3-3.

Low Friction Breakout Pressure indicates that the breakout required a lower force than configured by the user. Refer to figure 3-3.

Action On a Failed Test defines if the valve should step or ramp back on a failed stroke test.

Auto Test Interval is the interval of time in days between valve stroke tests that are automatically executed by the digital valve controller, subject to the device being powered up. A value of 0 disables this feature.

Partial Stroke Parameters

Minimum Travel Movement is the percentage of total span that the valve moves away from its normal operating end of travel towards its tripped end of travel during the test. The default value is 10%.

Short Duration PST, when enabled the incoming stroke is initiated as soon as the travel reaches the minimum travel movement. Refer to figure 3-4 for a time series representation of this parameter.

Figure 3-4. Time Series Representation of Short Duration PST

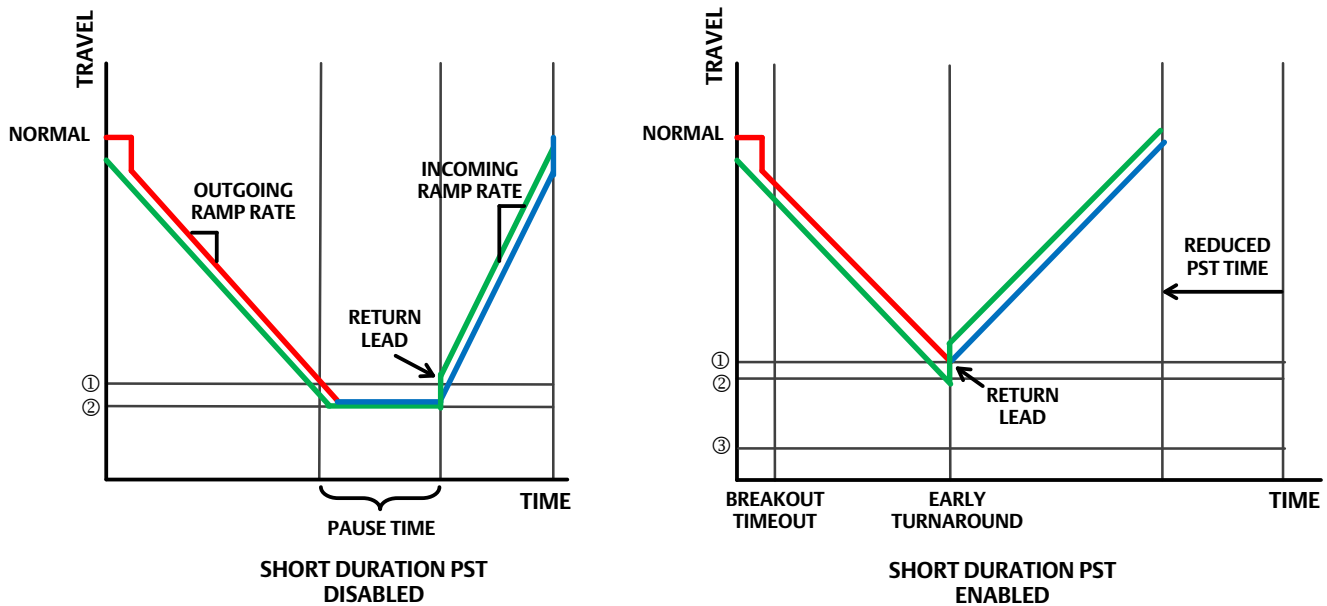

- ① MINIMUM TRAVEL MOVEMENT
- ② TRAVEL TARGET MOVEMENT
- ③ MAX. ALLOWABLE TRAVEL

Outgoing Ramp Rate is the rate at which the valve will move during the Outgoing stroke of the Partial Stroke test. The default value is 0.25%/second.

Incoming Ramp Rate is the rate at which the valve will move during the Incoming stroke of the Partial Stroke test. The default value is 0.25%/second.

Return Lead defines the percent (%) change in setpoint to overcome the hysteresis in the valve assembly. The error between setpoint and actual error is added to this percent change. For example, if the Return Lead is set at 0.5% and there is a 1% error this will be set at 1.5%

Breakout Timeout is the user configured amount of time before which the valve must leave the normal end during a PST.

Outgoing Pressure Threshold defines the actuator pressure at which a partial stroke test will abort during the outgoing stroke (see figure 3-3). This prevents the DVC6200 SIS from exhausting (or building) excessive pressure from/to the actuator in an attempt to move a stuck valve. During PST Calibration, the Partial Stroke Outgoing Pressure Threshold will be set automatically as follows:

- **Single Acting Actuators** - For those actuators that exhaust pressure from the partial test start point, the Outgoing Pressure Threshold will be a minimum value. For those actuators that build pressure from the partial test start point, the Outgoing Pressure Threshold will be a maximum value.
- **Double Acting Actuators** - The Outgoing Pressure Threshold will be set to a negative value for actuators where the partial stroke start point is opposite of the Zero Power Condition (e.g., Partial Stroke Start Point = *Open* and Zero Power Condition = *Closed*) and to a positive value for actuators where the partial stroke start point is the same as the Zero Power Condition.

The pressure signal used to determine this parameter depends on relay type and is summarized below.

Relay Type	Pressure Signal
A or C	Port A - Port B
B	Port B - Port A
B Special App.	Port B
C Special App.	Port A

To manually set the partial stroke Outgoing Pressure Threshold, you must examine current partial stroke test results using ValveLink software. The following steps will guide you through the process:

1. Connect the DVC6200 SIS to a system running ValveLink software.
2. Disable Partial Stroke Outgoing Pressure Limit by ensuring it is not selected as an evaluation criteria for PST Abnormal.
3. Run a partial stroke test.
4. Select the Press/Time radio button on the partial stroke graph (refer to the example in figure 3-5). If the actuator pressure starts high and moves low, find the minimum actuator pressure (Pmin). If the actuator pressure starts low and moves high, find the maximum actuator pressure (Pmax). Double-acting actuators will display differential pressure. Use table 3-7 to estimate the Outgoing Pressure Threshold.
5. Enable the previously disabled Outgoing Pressure Limit - calculate the value using table 3-7.

Table 3-7. Estimates for Outgoing Partial Stroke Pressure Limits

Actuator Style	Relay Type	Zero Power Condition	PST Starting Point	Partial Stroke Pressure Limit
Spring and Diaphragm	A or C	Closed	Open	$P_{min} - 0.25 * (\text{Bench Set High} - \text{Bench Set Low})$
			Closed	$P_{max} + 0.25 * (\text{Bench Set High} - \text{Bench Set Low})$
		Open	Open	$P_{max} + 0.25 * (\text{Bench Set High} - \text{Bench Set Low})$
			Closed	$P_{min} - 0.25 * (\text{Bench Set High} - \text{Bench Set Low})$
	B	Closed	Open	$P_{max} + 0.25 * (\text{Bench Set High} - \text{Bench Set Low})$
			Closed	$P_{min} - 0.25 * (\text{Bench Set High} - \text{Bench Set Low})$
		Open	Open	$P_{min} - 0.25 * (\text{Bench Set High} - \text{Bench Set Low})$
			Closed	$P_{max} + 0.25 * (\text{Bench Set High} - \text{Bench Set Low})$
Single Acting Piston	A or C	Closed	Open	$0.5 * P_{min}$
			Closed	$P_{max} + 0.5 * (P_{supply} - P_{max})$
		Open	Open	$P_{max} + 0.5 * (P_{supply} - P_{max})$
			Closed	$0.5 * P_{min}$
	B	Closed	Open	$P_{max} + 0.5 * (P_{supply} - P_{max})$
			Closed	$0.5 * P_{min}$
		Open	Open	$0.5 * P_{min}$
			Closed	$P_{max} + 0.5 * (P_{supply} - P_{max})$
Double Acting Piston	A	Closed	Open	$P_{min} - 0.5 * (P_{supply} + P_{min})$
			Closed	$P_{max} + 0.5 * (P_{supply} - P_{max})$
		Open	Open	$P_{max} + 0.5 * (P_{supply} - P_{max})$
			Closed	$P_{min} - 0.5 * (P_{supply} + P_{min})$

Figure 3-5. Example Time Series Plot; Actuator Pressure

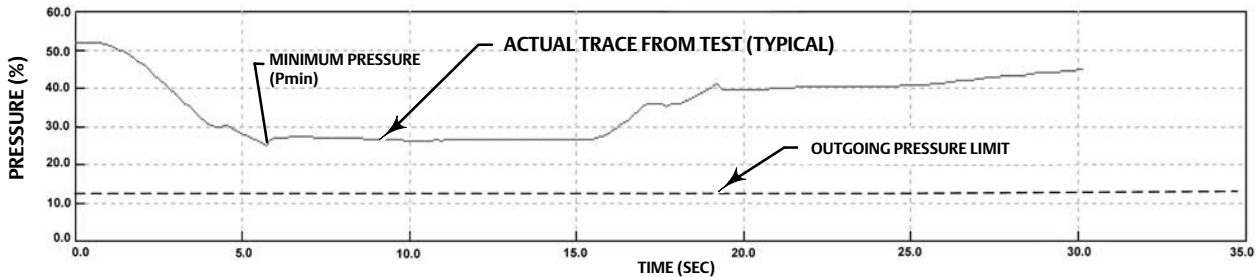

Incoming Pressure Threshold defines the actuator pressure at which a partial stroke test will abort during the incoming stroke (see figure 3-3). This prevents the DVC6200 SIS from exhausting (or building) excessive pressure from / to the actuator in an attempt to move a stuck valve.

PST Abnormal Criteria

A partial stroke test is marked as abnormal if it fails any of the following user-selected criteria.

1. Stroking Pressure (includes outgoing and incoming)
2. Hi friction breakout pressure
3. Low friction breakout pressure
4. Max travel
5. Insufficient travel

6. Not seated (either at the start or end of the test)
7. SOV Test preceded PST and failed
8. Travel deviation

PST Abort Criteria

The PST is terminated and the valve is returned to the normal end. The return to the normal end will be per the user configuration for an aborted test. The abort criteria will only be active if it is added as a criteria to be evaluated during PST by adding it to the PST Abnormal Criteria.

The user can select any of the following to abort a Partial Stroke Test:

1. Stroking Pressure (includes outgoing and incoming)
2. Hi friction breakout pressure
3. Low friction breakout pressure
4. Max travel
5. Insufficient travel
6. Not seated (either at the start or end of the test)
7. SOV Test preceded PST and failed
8. Travel deviation

PST Prohibited

A partial stroke test will not be initiated if any of the following user-configurable conditions are active:

1. Flash Integrity Failure
2. Minor Loop Sensor Failure
3. Reference Voltage Failure
4. Drive Current Failure
5. Critical NVM Failure
6. Temperature Sensor Failure
7. Pressure Sensor Failure
8. Travel Sensor Failure
9. Supply Pressure Low
10. Travel Deviation
11. Pressure Fallback active

SIS Options

- **Loop-Initiated PST**, when this feature is enabled, the digital valve controller will run a partial stroke test if the loop current is set to within $\pm 0.5\%$ of the PST trip point. The loop current must remain at that point for the duration of the test. To abort the test, the loop current must be returned to the normal or tripped current. This feature is disabled by default. This feature is not available when a local control panel is installed.
 - **PST Trip Point (ETT)** is the point at which the loop current must be set to run a partial stroke test for energize-to-trip applications. This value is not configurable and is preset at 8 mA.
 - **PST Trip Point (DETT)** is the point at which the loop current must be set to run a partial stroke test for de-energize-to-trip applications. This value is not configurable and is preset at 16 mA.
- **Latch on Position Trip**— The device will take the output to the trip state if the loop current is normal and the travel crosses the threshold towards the trip end. The position latch reset is always manual reset. The latch can be cleared by using one of the the user interfaces, a local control panel, or recycling power to the device. Select enable or disable.

Note

The condition that caused the valve to drift toward the trip end must be corrected before the manual reset is done. For example, if supply pressure droop caused the drift, the supply pressure must be restored before the manual reset is performed.

- **Position Trip Point** is defined as a % of travel from the trip end.
- **Change Reset Mode** defines the latching behavior of the DVC6200 SIS after a trip has occurred. There are three choices available.
 - **Auto Reset**— The valve will follow the loop signal from the logic solver and will not latch in the tripped position.
 - **Manual Reset**— The valve will latch in the tripped position until the loop signal from the logic solver is at the normal state *and* the DVC6200 SIS is reset. The reset signal can be initiated by a Local Control Panel, discrete switch wired to the AUX terminals, or from a HART command through the user interface.
 - **Smart Auto Reset**— The valve will latch in the tripped position until the originating source that tripped the valve provides a reset signal. If the logic solver trips the valve, and the local control panel trip button is not pressed, then the logic solver can return the valve to the normal position. However, if the local control panel trip button is pressed, then the local control panel is required to reset the valve to the normal position. (Note that the local control panel can issue a “pre-approval” if the reset button is pressed while the logic solver is still tripped. When the logic solver attempts to return the valve to the normal state, the DVC6200 SIS will follow.)
- **Action on Failed Test**—This displays the action taken by the instrument if a communication timeout occurs. Values are Ramp Back or Step Back.

Solenoid Valve Test

The DVC6200 SIS can be used to test and evaluate the operation of an external solenoid valve (SOV). This is accomplished by briefly removing power to the solenoid valve and examining the resulting pressure drop across the solenoid valve.

If the solenoid valve is connected directly to a logic solver, then the DVC6200 SIS can be used to monitor the pressures while the logic solver momentarily trips the solenoid valve. ValveLink Software can gather the data and provide a graphical representation of the actuator pressure and valve travel. Refer to the Monitoring Health of External Solenoid Valve (SOV) with FIELDVUE DVC6200 SIS Digital Valve Controllers Instruction Manual Supplement ([D104028X012](#)) for further details.

If the solenoid valve is wired in series with the DVC6200 SIS and logic solver, then the DVC6200 SIS can be used to initiate the momentary trip. For instructions on the physical pneumatic and electrical connections refer to the Quick Start Guide ([D103556X012](#)).

Instrument Configuration to Support SOV Testing

- **Relay Type**— Select the appropriate relay (B or C) with the “special app” designation. Special app refers to the additional tubing (monitoring line) that is installed between the unused output port of the DVC6200 SIS and a connection downstream of the solenoid valve, close to the actuator.
- **Output Terminal Function**— Since the solenoid valve is wired through the output terminals of the DVC6200 SIS, the terminals must be enabled and configured as “SOV Test”. Note that the Transmitter/Switch selection on the printed wiring board (PWB) must also be set to “Switch”.

SOV Test Parameters (see figure 3-6)

- **Pulse Duration** is the length of time of the momentary power disruption to the solenoid valve. It should be long enough to detect a Trip Pressure Differential, but short enough to not cause the SIS valve to move. This is automatically determined during the SOV Test Calibration routine.
- **Monitoring Time** is the length of time from the start of the test (pulse initiation), to the end of the data gathering. It should be long enough to allow the Reset Pressure Differential to stabilize.
- **Trip Pressure Differential**— During the momentary solenoid valve trip, the pressure drop across the solenoid valve is measured. This value is the maximum pressure drop recorded during the SOV test. It is determined automatically during the SOV Test Calibration routine.

Figure 3-6. Graphical Representation of SOV Test Parameters

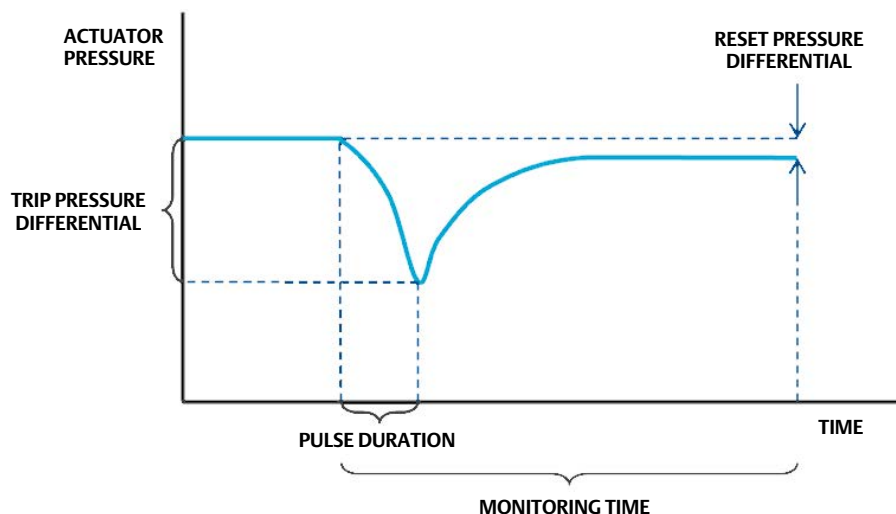

- **Reset Pressure Differential**— After the solenoid valve is momentarily tripped, the pressure differential across the solenoid valve should reduce back to zero. However, depending on the Monitoring Time, the downstream pressure may not fully recover at the end of the test. This value is automatically determined during the SOV Test Calibration routine.
- **SOV Test before PST** configures the device to always run a SOV test prior to a PST test any time a PST is initiated.
- **On Abnormal SOV Test** — If SOV Test before PST is configured, this determines the behavior if the SOV test result is abnormal. The configuration choices are to continue on to the PST, or cancel the PST.
- **Independent SOV Test** configures the device to allow a SOV Test to be run independent of a PST test.

SOV Test Alerts

- **Trip Pressure Alert Point**— During an SOV Test, if the trip pressure differential is lower than this value, the alert will be active.
- **Reset Pressure Alert Point**— During an SOV Test, if the reset pressure differential exceeds this value, the alert will be active.

Outputs

Device Communicator

Configure > Manual Setup > Outputs (2-2-6)

Output Terminal Configuration

- **Output Terminal Enable**—If using the output terminal for a Position Transmitter or Switch Output, or for Solenoid Valve Testing, this must be Enabled.
- **Function**—The output terminals can be configured as one of the following:
 - Transmitter - 4-20 mA output that represents 0-100% of the calibrated valve travel.
 - Limit Switch - Discrete switch (1A max) that trips at a configurable point within 0-100% of calibrated valve travel.
 - Alert Switch - Discrete switch (1A max) that trips based on a configurable device alert.
 - SOV Test – Normally closed discrete switch that momentarily opens during a solenoid valve test.
- **Fail Signal**—Should the output circuit fail to operate properly the output will attempt to drive to a known state. Depending on the nature of the failure, the circuit may or may not be able to achieve this fail state. When configured as a position transmitter, the output can be configured to fail low (< 3.6 mA). The output can be configured to fail high (> 22.5 mA) when the digital valve controller is powered. When configured as a switch, the output can be configured to drive Closed or Open.

Note

On loss of digital valve controller power, the switch circuit will always go to the open state.

Switch Configuration

- **Limit Switch Trip Point** defines the threshold for the limit switch in percent of calibrated travel when the function is configured as a Limit Switch.

- **Alert Switch Source** determines which alert will activate the switch when the function is configured as a Alert Switch. The alert choices are: Travel Deviation, Valve Stuck, LCP Tripped, SIS Diagnostic Credit, or Diagnostic in Progress.
- **Switch Closed** configures the action of the switch. The choices are: Below Trip Point / Alert Not Active or Above Trip Point / Alert Active.

HART Variable Assignments

Instrument variables can be reported via four different HART variable assignments. The Primary Variable is always configured as Analog Input. However, the remaining three variables have additional options as listed below.

Primary Variable (PV)	Analog Input
Secondary Variable (SV)	Travel, Travel Setpoint, Pressure A, Pressure B, Pressure A-B, Supply Pressure, Drive Signal, or Analog Input
Tertiary Variable (TV)	Travel, Travel Setpoint, Pressure A, Pressure B, Pressure A-B, Supply Pressure, Drive Signal, or Analog Input
Quaternary Variable (QV)	Travel, Travel Setpoint, Pressure A, Pressure B, Pressure A-B, Supply Pressure, Drive Signal, or Analog Input

Transmitter Output

This configures the relationship between the valve travel and the position transmitter output signal. There are two choices; 4mA = Valve Closed or 4mA = Valve Open.

Burst Mode

Burst mode provides continuous communication from the digital valve controller. Burst mode applies only to the transmission of burst mode data (HART Variable Assignments) and does not affect the way other data is accessed.

- **Burst Enable**—This turns on or off the burst mode.
- **Burst Command**—This defines which HART command is configured for burst reporting. When using a Tri-Loop, select Command 3.

HART 5

- Analog Input (Command 1)
- Loop Current / Travel (Command 2)
- Loop Current / PV / SV / TV / QV (Command 3)

HART 7 -

- Analog Input (Command 1)
- Loop Current / Travel (Command 2)
- Loop Current / PV / SV / TV / QV (Command 3)
- Read Device Variable with Status (Command 9)
- Read Device Variables (Command 33)
- Read Additional Status (Command 48)

Notes

Access to information in the instrument is normally obtained through the poll/response of HART communication. The Device Communicator or the control system may request any of the information that is normally available, even while the instrument is in burst mode. Between each burst mode transmission sent by the instrument, a short pause allows the Device Communicator or control system to initiate a request. The instrument receives the request, processes the response message, and then continues “bursting” the burst mode data.

Burst mode will be automatically disabled during diagnostics tests such as Valve Signature.

HART 7 allows three burst commands to be reported. When using a Tri-Loop, do not enable the 2nd or 3rd burst commands. These additional commands will result in missed messages, thus taking the Tri-Loop's output to the fault state.

Alert Setup

Device Communicator	Configure > Alert Setup (2-3)
---------------------	-------------------------------

An alert is a notification that the instrument has detected a problem. Alerts that are enabled and active will be recorded in the instrument memory within the Alert Record (see Section 5). Some alerts are also defined in the HART Command 48 response structure which is can be read by any HART communicating host system (refer to the DVC6200 SIS HART Field Device Specification, [D103638X012](#)).

Certain critical alerts can be configured to shut down the device when active (i.e. latch in the Zero Power Condition). This can be enabled or disabled for each applicable alert. The default shutdown setting is disabled. To clear the shutdown, correct the problem and then cycle power to the instrument (or disable the alert).

Alerts may be enabled or disabled with the instrument In Service, Out of Service, Protection On, or Protection Off. However, shutdown alerts can only be enabled or disabled while Protection is off.

For a detailed explanation of the alerts and the recommended actions, refer to Section 5.

Change to HART 5 / Change to HART 7

Device Communicator	Service Tool > Maintenance > Change to HART 5 / Change to HART 7 (3-5-3)
---------------------	--

This procedure changes the instrument from HART Universal Revision 5 to HART Universal Revision 7 (or vice versa). Before proceeding, verify that your systems are prepared to support HART Universal Revision 7 devices. Follow the prompts on the Device Communicator display.

Note

This procedure must never be done while the valve is in service and controlling the process. Depending on the control system or asset management system attached, complete system reset may be required to reestablish HART communication. Consult the system documentation for further information.

Section 4 Calibration

Note

Fast-key sequences are only applicable to the 475 Field Communicator. They do not apply to the Trex Device Communicator.

Calibration Overview

When a DVC6200 SIS digital valve controller is ordered as part of a control valve assembly, the factory mounts the digital valve controller on the actuator and connects the necessary tubing, then sets up and calibrates the controller.

For digital valve controllers that are ordered separately, recalibration of the analog input or pressure sensors generally is unnecessary. However, after mounting on an actuator, perform the initial setup then calibrate travel by selecting *Configure > Calibration > Travel Calibration > Auto Calibration*. For more detailed calibration information, refer to the following calibration procedures.

Device Communicator	Configure > Calibration (2-4)
---------------------	-------------------------------

Auto Travel Calibration - see page 38

Manual Travel Calibration - see page 39

Pushbutton Calibration - see page 40

Pressure Sensor Calibration - see page 41

Analog Input Calibration - see page 42

Relay Adjustment - see page 43

PST Calibration - see page 45

SOV Test Calibration - see page 45

Note

The Instrument Mode must be Out Of Service and the Protection set to None before the instrument can be calibrated.

If you are operating in burst mode, we recommend that you disable burst before continuing with calibration. Once calibration is complete, burst mode may then be turned back on.

WARNING

During calibration the valve will move full stroke. To avoid personal injury and property damage caused by the release of pressure or process fluid, isolate the valve from the process and equalize pressure on both sides of the valve or bleed off the process fluid.

Travel Calibration

If a double-acting relay is used, you will be prompted to run the relay adjustment when auto or manual calibration is selected. Select Yes to adjust the relay, select No to proceed with calibration. For additional information, refer to Relay Adjustment on page 43.

Auto Calibration

1. The auto calibration procedure is automatic. It is completed when the *Calibration* menu appears.

During calibration, the instrument seeks the high and low end points and the minor loop feedback (MLFB) and output bias. By searching for the end points, the instrument establishes the limits of physical travel, i.e. the actual travel 0 and 100% positions. This also determines how far the relay beam swings to calibrate the sensitivity of the MLFB sensor.

2. Place the instrument In Service and verify that the travel properly tracks the current source.

If the unit does not calibrate, refer to table 4-1 for error messages and possible remedies.

Table 4-1. Auto Calibrate Travel Error Messages

Error Message	Possible Problem and Remedy
Power failure occurred during Auto Calib	The analog input signal to the instrument must be greater than 3.8 mA. Adjust the current output from the control system or the current source to provide at least 4.0 mA.
Auto Calib did not complete within the time limit.	The problem may be one or the other of the following: 1. The tuning set selected is too low and the valve does not reach an end point in the allotted time. Select <i>Manual Setup > Tuning > Travel Tuning > Stabilize/Optimize</i> then <i>Increase Response</i> (selects next higher tuning set). 2. The tuning set selected is too high, valve operation is unstable and does not stay at an end point for the allotted time. Select <i>Manual Setup > Tuning > Travel Tuning > Stabilize/Optimize</i> then <i>Decrease Response</i> (selects next lower tuning set).
Insufficient travel	Prior to receiving this message, did the instrument output go from zero to full supply? If not, verify instrument supply pressure by referring to the specifications in the appropriate actuator instruction manual. If supply pressure is correct, check instrument pneumatic components (I/P converter and relay). If the instrument output did go from zero to full supply prior to receiving this message, then verify proper mounting by referring to the appropriate mounting procedure in the Installation section and checking the magnet array for proper alignment.
Drive signal exceed low limit; check supply pressure	1. Check supply pressure (reverse-acting relay) 2. Friction is too high.
Drive signal exceed high limit; check supply pressure	1. Check supply pressure (direct-acting relay) 2. Friction is too high

Manual Calibration

Two procedures are available to manually calibrate travel:

- Analog Adjust— This procedure is used when you can manually change the 4-20 mA current source to move the valve.
- Digital Adjust— This procedure is used when the 4-20 mA current source cannot be manually changed.

Analog Calibration Adjust

Connect a variable current source to the instrument LOOP + and LOOP - terminals. The current source should be capable of generating 4 to 20 mA.

Follow the prompts on the Device Communicator display to calibrate the instrument's travel in percent.

Note

0% Travel = Valve Closed
100% Travel = Valve Open

1. Adjust the input current until the valve is near mid-travel. Press OK.

Note

In steps 2 through 7 the accuracy of the current source adjustment affects the position accuracy.

2. Adjust the current source until the valve is at 0% travel, then press OK.
3. Adjust the current source until the valve is at 100% travel, then press OK.
4. Adjust the current source until the valve is at 0% travel, then press OK.
5. Adjust the current source until the valve is at 100% travel, then press OK.
6. Adjust the current source until the valve is at 5% travel, then press OK.
7. Adjust the current source until the valve is at 95% travel, then press OK.
8. Place the instrument In Service and verify that the travel properly tracks the current source.

Digital Calibration Adjust

Connect a variable current source to the instrument LOOP + and LOOP - terminals. The current source should be set between 4 and 20 mA.

Follow the prompts on the Device Communicator display to calibrate the instrument's travel in percent.

1. Adjust the input current until the valve is near mid-travel. Press OK.

Note

0% Travel = Valve Closed
100% Travel = Valve Open

2. From the adjustment menu, select the direction and size of change required to set the travel at 0%.
Selecting large, medium, and small adjustments causes changes of approximately 10.0%, 1.0%, and 0.1%, respectively. If another adjustment is required, repeat step 2. Otherwise, select Done and go to step 3.
3. From the adjustment menu, select the direction and size of change required to set the travel to 100%.
If another adjustment is required, repeat step 3. Otherwise, select Done and go to step 4.
4. From the adjustment menu, select the direction and size of change required to set the travel at 0%.
If another adjustment is required, repeat step 4. Otherwise, select Done and go to step 5.
5. From the adjustment menu, select the direction and size of change required to set the travel to 100%.
If another adjustment is required, repeat step 5. Otherwise, select Done and go to step 6.
6. From the adjustment menu, select the direction and size of change required to set the travel to 5%.
If another adjustment is required, repeat step 6. Otherwise, select Done and go to step 7.
7. From the adjustment menu, select the direction and size of change required to set the travel to 95%.
If another adjustment is required, repeat step 7. Otherwise, select Done and go to step 8.
8. Place the instrument In Service and verify that the travel properly tracks the current source.

Pushbutton Calibration

A pushbutton near the wiring terminals in the terminal box provides a quick means to autocalibrate the instrument. The button must be pressed for 3 to 10 seconds. Autocalibration will move the valve through the full range of travel whether the Instrument Mode is In Service or Out of Service. However, if the Write Protection is Protected, this button will not be active. To abort, press the button again for 1 second. The calibration button is disabled by default. To enable it, go to *Manual Setup > Instrument > Calibration Button*.

Note

The autocal pushbutton will not be active if the instrument is Locked in Safety.

This calibration procedure is recommended whenever the I/P converter or pneumatic relay is replaced. Do not use the pushbutton calibration for initial calibration when mounting the instrument on an actuator, or if the printed wiring board assembly was replaced.

If you suspect calibration has changed due to drift, first perform a Valve Signature diagnostic test using ValveLink software to capture the as-found data for future root cause analysis.

Sensor Calibration

Pressure Sensors

Note

The pressure sensor is calibrated at the factory and should not require calibration.

Output Pressure Sensor

To calibrate the output pressure sensor, connect an external reference gauge to the output being calibrated. The gauge should be capable of measuring maximum instrument supply pressure. Depending upon the sensor you wish to calibrate, select either *Output A Sensor* or *Output B Sensor*. Follow the prompts on the Device Communicator display to calibrate the instrument's output pressure sensor.

1. Adjust the supply pressure regulator to the maximum instrument supply pressure. Press OK.
2. The instrument reduces the output pressure to 0. The following message appears.

Use the Increase and Decrease selections until the displayed pressure matches the output x pressure.

Press OK when you have read the message.

3. The value of the output pressure appears on the display. Press OK to display the adjustment menu.
4. From the adjustment menu, select the direction and size of adjustment to the displayed value.

Selecting large, medium, and small adjustments causes changes of approximately 3.0 psi/0.207 bar/20.7 kPa, 0.30 psi/0.0207 bar/2.07 kPa, and 0.03 psi/0.00207 bar/0.207 kPa, respectively.

If the displayed value does not match the output pressure, press OK, then repeat this step (step 4) to further adjust the displayed value. When the displayed value matches the output pressure, select Done and go to step 5.

5. The instrument sets the output pressure to full supply. The following message appears.

Use the Increase and Decrease selections until the displayed pressure matches the output x pressure.

Press OK when you have read the message.

6. The value of the output pressure appears on the display. Press OK to display the adjustment menu.
7. From the adjustment menu, select the direction and size of adjustment to the displayed value. If the displayed value does not match the output pressure, press OK, then repeat this step (step 7) to further adjust the displayed value. When the displayed value matches the output pressure, select Done and go to step 8.
8. Place the instrument In Service and verify that the displayed pressure matches the measured output pressure.

Supply Pressure Sensor

To calibrate the supply pressure sensor, connect an external reference gauge to the output side of the supply regulator. The gauge should be capable of measuring maximum instrument supply pressure. Follow the prompts on the Device Communicator display to calibrate the instrument's supply pressure sensor.

1. Select a) Zero Only, or b) Zero and Span (gauge required).
 - a. If Zero Only calibration is selected, adjust the supply pressure regulator to remove supply pressure from the instrument. Press OK. Once calibration is complete, go to step 5.
 - b. If Zero and Span calibration is selected, adjust the supply pressure regulator to remove supply pressure from the instrument. Press OK. Adjust the supply regulator to the maximum instrument supply pressure. Press OK. Proceed with step 2.
2. The following message appears:

Use the Increase and Decrease selections until the displayed pressure matches the supply pressure.

Press OK when you have read this message.

3. The value of the pressure appears on the display.
4. From the adjustment menu, select the direction and size of adjustment to the displayed value.

Selecting large, medium, and small adjustments causes changes of approximately 3.0 psi/0.207 bar/20.7 kPa, 0.30 psi/0.0207 bar/2.07 kPa, and 0.03 psi/0.00207 bar/0.207 kPa, respectively.

Adjust the displayed value until it matches the supply pressure, select Done and go to step 5.

5. Place the instrument In Service and verify that the displayed pressure matches the measured supply pressure.

Analog Input Calibration

To calibrate the analog input sensor, connect a variable current source to the instrument LOOP+ and LOOP- terminals. The current source should be capable of generating an output of 4 to 20 mA. Follow the prompts on the Device Communicator display to calibrate the analog input sensor.

1. Set the current source to the target value shown on the display. The target value is the Input Range Low value. Press OK.
2. The following message appears:

Use the Increase and Decrease selections until the displayed current matches the target.

Press OK when you have read this message.

3. The value of the Analog Input appears on the display. Press OK to display the adjustment menu.
4. From the adjustment menu, select the direction and size of adjustment to the displayed value.

Selecting large, medium, and small adjustments causes changes of approximately 0.4 mA, 0.04 mA, and 0.004 mA, respectively.

If the displayed value does not match the current source, press OK, then repeat this step (step 4) to further adjust the displayed value. When the displayed value matches the current source, select Done and go to step 5.

5. Set the current source to the target value shown on the display. The target value is the Input Range High value. Press OK.
6. The following message appears:

Use the Increase and Decrease selections until the displayed current matches the target.

Press OK when you have read this message.

7. The value of the Analog Input appears on the display. Press OK to display the adjustment menu.
8. From the adjustment menu, select the direction and size of adjustment to the displayed value. If the displayed value does not match the current source, press OK, then repeat this step (step 8) to further adjust the displayed value. When the displayed value matches the current source, select Done and go to step 9.
9. Place the instrument In Service and verify that the analog input displayed matches the current source.

Relay Adjustment

Before beginning travel calibration, check the relay adjustment. Replace the digital valve controller cover when finished.

Note

Relay B and C are not user-adjustable.

Double-Acting Relay

The double-acting relay is designated by “Relay A” on a label affixed to the relay itself. For double-acting actuators, the valve must be near mid-travel to properly adjust the relay. The Device Communicator will automatically position the valve when *Relay Adjust* is selected.

Rotate the adjustment disc, shown in figure 4-1, until the output pressure displayed on the Device Communicator is between 50 and 70% of supply pressure. This adjustment is very sensitive. Be sure to allow the pressure reading to stabilize before making another adjustment (stabilization may take up to 30 seconds or more for large actuators).

Low bleed relay stabilization may take approximately two minutes longer than the standard relay.

Figure 4-1. Relay A Adjustment (Shroud Removed for Clarity)

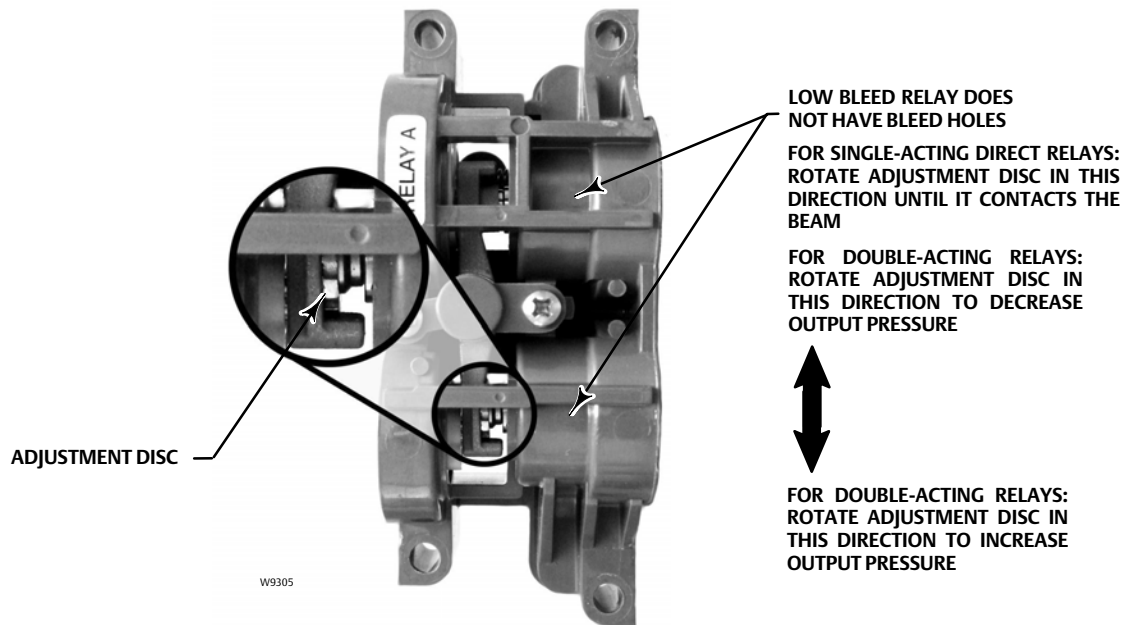

Relay A may also be adjusted for use in single-acting- direct applications. Rotate the adjustment disc as shown in figure 4-1 for single-acting direct operation.

CAUTION

Care should be taken during relay adjustment as the adjustment disc may disengage if rotated too far.

Single-Acting Relays

⚠ WARNING

If the unused port is monitoring pressure, ensure that the pressure source conforms to ISA Standard 7.0.01 and does not exceed the pressure supplied to the instrument.

Failure to do so could result in personal injury or property damage caused by loss of process control.

Single-Acting Direct Relay

The single-acting direct relay is designated by “Relay C” on a label affixed to the relay itself. Relay C requires no adjustment.

Single-Acting Reverse Relay

The single-acting reverse relay is designated by “Relay B” on a label affixed to the relay itself. Relay B is calibrated at the factory and requires no further adjustment.

PST Calibration

This procedure permits you to run the Partial Stroke Calibration, which enables the Partial Stroke Test. It establishes values for Partial Stroke Pressure Limit, Pressure Set Point and Pressure Saturation Time for End Point Pressure Control, Travel Deviation Alert Point and Travel Deviation Time. The Partial Stroke Calibration also sets default values for max travel movement, test speed, and test pause time.

Note

You must take the instrument out of service before running Partial Stroke Calibration.

Ensure that the instrument is put back in service after the completing the calibration procedure.

SOV Test Calibration

This procedure is used when a solenoid valve is wired to the Output terminals. During this routine, the output terminal circuit is interrupted momentarily to trip the solenoid. During the test, the Trip Pressure Differential, Recovery Pressure Differential, and Valve Travel are monitored. The test attempts to find the optimal trip duration which results in a measurable pressure drop across the solenoid, but no valve travel movement. If the proper duration cannot be established within 10 tries, the test will stop.

Section 5 Device Information, Alerts, and Diagnostics

Note

Fast-key sequences are only applicable to the 475 Field Communicator. They do not apply to the Trex Device Communicator.

Overview

Device Communicator	Overview (1)
---------------------	--------------

Status & Primary Purpose Variables

The overview section provides basic information about the current state of the instrument and gives you access to the current values of:

- Alert Status
- Communication Status
- Instrument Mode (In/Out of Service)
- Analog Input
- Setpoint
- Travel
- Supply Pressure
- Actuator Pressure(s)

Device Information

Device Information provides details about the instrument construction including:

- Tag Name
- Instrument Model Number
- Instrument Level
- Device ID (unique number used to prevent the instrument from accepting commands intended for other instruments)
- Serial Numbers
- Firmware, DD, and Hardware Revisions
- HART Universal Revision
- Write Protection (provides a procedure to enable/disable)

Service Tools

Device Communicator	Service Tools (3)
---------------------	-------------------

Device Status

Instrument alerts, when enabled, detect many operational and performance issues that may be of interest. If there are no alerts currently active, this display will be empty.

Alert Record

The DVC6200 SIS will store 20 alerts. Once the alert record is full, no additional alerts will be stored until the record is cleared.

Alert Reporting

In addition to on-board storage of alerts, the DVC6200 SIS can report active alerts via HART Command 48 - Read Additional Status. Refer to table 5-1 for a summary of the default alert settings from the factory. Following is a detailed description of the meaning of each alert.

Table 5-1. Default Alert Settings

Name	Alert	Shutdown	NE107 Category
Flash Integrity Failure	Enabled ⁽¹⁾	Disabled	Failure
Minor Loop Sensor Failure	Enabled ⁽¹⁾	Disabled	Failure
Reference Voltage Failure	Enabled ⁽¹⁾	Disabled	Failure
Drive Current Failure	Enabled ⁽¹⁾	Disabled	Failure
Critical NVM Failure	Enabled ⁽¹⁾	Disabled	Failure
Temperature Sensor Failure	Enabled ⁽¹⁾	Disabled	Failure
Pressure Sensor Failure	Enabled ⁽¹⁾	Disabled	Failure
Travel Sensor Failure	Enabled ⁽¹⁾	Disabled	Failure
Alert Record Not Empty	Disabled	Not Available	Maintenance
Tripped by the LCP	Disabled	Not Available	Not Available
Calibration in Progress	Disabled	Not Available	Function Check
Diagnostics in Progress	Disabled	Not Available	Function Check
Pressure Fallback Active	Enabled	Not Available	Out of Specification
SIS Program Flow Failure	Enabled	Disabled	Failure
Autocal in Progress	Disabled	Not Available	Function Check
SIS Hardware Failure	Enabled	Disabled	Failure
Non-Critical NVM	Enabled ⁽¹⁾	Disabled	Failure
Cycle Counter High	Disabled	Not Available	Maintenance
Travel Accumulator High	Disabled	Not Available	Maintenance
Instrument Time is Approximate	Disabled	Not Available	Not Available
Alert Record Full	Disabled	Not Available	Maintenance
Offline / Failed	Enabled	Not Available	Failure
SIS Stroke Performance	Disabled	Not Available	Out of Specification

1. These default alert configurations cannot be changed.

-continued-

Table 5-1. Default Alert Settings (continued)

Name	Alert	Shutdown	NE107 Category
Diagnostic Data Available	Disabled	Not Available	Not Available
PST Abnormal	Enabled	Not Available	Out of Specification
Supply Pressure Low	Enabled	Not Available	Out of Specification
End Point Pressure Deviation	Enabled	Not Available	Out of Specification
Manual Reset Required	Disabled	Not Available	Not Available
Supply Pressure High	Enabled	Not Available	Maintenance
Integrator Saturated High	Disabled	Not Available	Out of Specification
Integrator Saturated Low	Disabled	Not Available	Out of Specification
Travel Alert Low	Disabled	Not Available	Not Available
Travel Alert Low-Low	Disabled	Not Available	Not Available
Travel Alert High	Disabled	Not Available	Not Available
Travel Alert High-High	Disabled	Not Available	Not Available
Travel Deviation	Enabled	Not Available	Out of Specification
Travel Cutoff High	Disabled	Not Available	Not Available
Travel Cutoff Low	Disabled	Not Available	Not Available
Drive Signal Alert	Enabled	Not Available	Out of Specification
PST Pass	Enabled	Not Available	Not Available
PST Prohibited	Enabled	Not Available	Not Available
LCP Stuck Button	Enabled	Not Available	Failure
LCP Communications Failure	Enabled	Not Available	Failure
Output Circuit Error	Enabled	Not Available	Failure
Port A Overpressurized	Enabled	Disabled	Failure

Alert Record Full is active when the alert record is full. Additional alerts that are detected will not be saved to the alert record until the alert record is cleared.

Alert Record Not Empty is active when there are 1 or more alerts stored in the alert record.

Autocal in Progress is active when auto calibration is in progress.

Calibration in Progress is active when calibration is in progress.

Critical NVM Failure is active if there is a failure associated with NVM that is critical for instrument operation. To clear the alert, restart the instrument. If the alert persists, replace the printed wiring board assembly.

Cycle Counter High is active if the Cycle Counter exceeds the Cycle Count Alert Point. The Cycle Count records the number of times the travel changes direction when it is outside of the deadband. To clear the alert, set the Cycle Counter to a value less than the alert point. See figure 5-2.

Diagnostic Data Available is active when diagnostic data has been collected and is being stored in the instrument.

Diagnostics in Progress is active when a diagnostic test is in progress.

Drive Current Failure is active when the drive current to the I/P converter is not flowing as expected. If this alert occurs, check the connection between the I/P converter and the printed wiring board assembly. Try removing the I/P converter and reinstalling it. If the alert does not clear, replace the I/P converter or the printed wiring board assembly.

Drive Signal Alert monitors the drive signal and calibrated travel. If one of the following conditions exists for more than 20 seconds, the alert is set.

For the case where Zero Power Condition is defined as closed:

Drive Signal < 10% and Calibrated Travel > 3%
Drive Signal > 90% and Calibrated Travel < 97%

For the case where Zero Power Condition is defined as open:

Drive Signal < 10% and Calibrated Travel < 97%
Drive Signal > 90% and Calibrated Travel > 3%

End Point Pressure Deviation is active if the instrument is in pressure control and the pressure is not tracking the set point within the configured deviation allowance.

Field Device Malfunction is active if the pressure, position, or temperature sensors are providing invalid readings.

Flash Integrity Failure is active if there is a failure associated with flash ROM (read only memory). To clear the alert, restart the instrument. If the alert persists, replace the printed wiring board assembly.

Instrument Time is Approximate is active if the instrument has been powered down since the last time the instrument clock was set. To clear the alert, reset the instrument time.

Integrator Saturated High is active if the instrument integrator is saturated at the high extreme.

Integrator Saturated Low is active if the instrument integrator is saturated at the low extreme.

Internal Sensor Out of Limits is active if there is a problem with either the pressure sensor or the printed wiring board assembly.

LCP Communications Failure is active if the AUX terminals are configured for use with the local control panel, but communication between the DVC6200 SIS and LCP is not occurring.

LCP Stuck Button is active if the instrument detects that a button on the local control panel is stuck in the activated position.

Loop Current Validation Alert is active if the loop current is significantly out of range, or if there is a problem with the analog circuit electronics. To clear the alert, restart the instrument with the loop current verified to be in the 4-20 mA range. If the alert persists, replace the printed wiring board.

Note

If the control system is known to output current 24 mA or above, Shutdown on Loop Current Validation should not be enabled.

Minor Loop Sensor Failure is active if the pneumatic relay position reading is outside the valid range. If the alert persists, replace the printed wiring board.

Non-Critical NVM is active if there is a failure associated with NVM (nonvolatile memory) that is not critical for instrument operation. To clear the alert, restart the instrument. If the alert persists, replace the printed wiring board assembly.

Offline / Failed is active if a shutdown alert has put the device in a failed state and is therefore not controlling the input. Examine the alert(s) that caused the shutdown.

Output Circuit Error is active if the output circuit is not responding. Verify that the DIP switch on the main electronics matches the configuration of the OUT terminals. If the DIP switch setting is correct and the alert is still active, replace the main electronics.

Port A Overpressurized requires that both the Port A Overpressurized Alert and the Port A Output Pressure Limit are enabled and applies to single acting direct applications only. The alert is active if the output pressure from Port A of the DVC6200 SIS exceeds the configured pressure limit setting. Check the supply pressure regulator for damage and verify its pressure set point.

Pressure Fallback Active is active when the instrument has detected a problem with the travel feedback and is now controlling the output like an I/P transducer.

Pressure Sensor Failure is active if any of the 3 pressure sensor readings (output A, output B, supply) are outside the range of 24.0 to 125.0% of the calibrated pressure for more than 60 seconds. If this alert is active, check the instrument supply pressure, ensure the printed wiring board assembly is properly mounted onto the module base assembly, and ensure the pressure sensor o-rings are properly installed. If the alert persists after restarting the instrument, replace the printed wiring board assembly.

PST Abnormal indicates that a partial stroke test has failed. The criteria for determining an abnormal partial stroke test is user configurable. See page 30 for PST Abnormal Criteria.

CAUTION

If a PST Abnormal alert is active, there may be potential energy stored in the valve and actuator assembly. Sudden release of this energy may cause the valve to suddenly open or close, resulting in equipment damage.

PST Prohibited indicates that a partial stroke test was initiated, but then aborted due to abnormal conditions. The criteria for prohibiting a partial stroke test is user configurable. See page 31 for PST Prohibited criteria.

PST Pass indicates that a partial stroke test has completed normally. This alert will automatically clear. The timeout setting for the alert shares the same configuration setting as the Tripped by LCP Alert Latch.

Reference Voltage Failure is active if there is a failure associated with the internal voltage reference. If this alert is active, replace the printed wiring board assembly.

SIS Hardware Failure is active if a demand has occurred, but the electronics hardware failed to take control of the I/P drive.

Manual Reset Required indicates that the DVC6200 SIS is in the tripped position. In order for the instrument to follow the loop signal, it must be reset by pressing the Green button on the LCP, or perform a Reset Latch with the host.

SIS Program Flow Failure is active if the firmware is not performing the expected series of calculations.

SIS Stroke Performance— If the DVC6200 SIS is tripped to the safety position and/or returns to the normal position, the instrument will record the demand and/or return stroke time, demand break out time, and the calendar time that these events happened. This alert is active if any of the configured thresholds are exceeded.

Supply Pressure High is active if the supply pressure falls above the supply pressure high alert point.

Supply Pressure Low is active if the supply pressure falls below the supply pressure low alert point.

Temperature Sensor Failure is active when the instrument temperature sensor fails, or the sensor reading is outside of the range of -60 to 100°C (-76 to 212°F). The temperature reading is used internally for temperature compensation of inputs. If this alert is active, restart the instrument. If the alert persists, replace the printed wiring board assembly.

Travel Accumulator High is active if the Travel Accumulator exceeds the Travel Accumulator Alert Point. The Travel Accumulator totalizes the travel of the valve when the deadband is exceeded. To clear the alert, set the Travel Accumulator to a value less than the alert point. See figure 5-2.

Travel Alert Hi is active when the Travel exceeds the Travel Alert Hi Point. Once the alert is active, the alert will clear when the Travel falls below the Travel Alert Hi Point minus the Travel Alert Deadband. See figure 5-1.

Note

The Travel Alert Hi Hi and Travel Alert Lo Lo points are used to calculate the stroke time in the event of a demand. The values are typically set to 99% and 1% respectively, however it is not necessary to enable the alert. Stroke time can be read from the device with ValveLink software.

Travel Alert Hi-Hi is active when the Travel exceeds the Travel Alert Hi Hi Point. Once the alert is active, the alert will clear when the Travel falls below the Travel Alert Hi Hi Point minus the Travel Alert Deadband. See figure 5-1.

Travel Alert Lo is active when the Travel is below the Travel Alert Lo Point. Once the alert is active, the alert will clear when the Travel exceeds the Travel Alert Lo Point plus the Travel Alert Deadband. See figure 5-1.

Travel Alert Lo-Lo is active when the Travel is below the Travel Alert Lo Point. Once the alert is active, the alert will clear when the Travel exceeds the Travel Alert Lo Point plus the Travel Alert Deadband. See figure 5-1.

Travel Cutoff Hi is active when the Travel exceeds the Hi Cutoff Point.

Travel Cutoff Lo is active when the Travel falls below the Lo Cutoff Point.

Travel Deviation— If the difference between the Travel Target and the Travel exceeds the Travel Deviation Alert Point for more than the Travel Deviation Time, the Travel Deviation Alert is active. It remains active until the difference between the travel target and the Travel is less than the Travel Deviation Alert Point minus the Travel Alert Deadband. See figure 5-1.

Travel Sensor Failure is active if the sensed travel is outside the range of 25.0 to 125.0% of calibrated travel. If this alert is active, check the instrument mounting. Also, check that the electrical connection from the travel sensor is properly plugged into the printed wiring board assembly. After restarting the instrument, if the alert persists, troubleshoot the printed wiring board assembly or travel sensor.

Tripped by the LCP indicates that the DVC6200 SIS is in the tripped position as a result of someone pressing the trip button on the local control panel. This alert will automatically clear only after the valve returns to the normal state and the Tripped by LCP Alert Latch timeout has expired.

Variable out of Range is active if one or more of the measured analog sensor readings (loop current, pressure, temperature, or travel) is saturated or reading out of its configured range. The condition may be due to improper configuration or physical setup and not be due to a sensor malfunction.

Deadband Principle of Operation

The deadband is the percent (%) of ranged travel around a travel reference point where no change in alert status will occur. This prevents the alert from toggling on and off when operating near the alert point.

The Travel Alert Deadband applies to the Travel Deviation Alert as well as the Travel Alert Hi, Lo, Hi Hi, and Lo Lo. Figure 5-1 illustrates the principle behind setting and clearing a Travel Alert Hi. The alert is set when the travel exceeds the alert point, and is cleared when it falls below the deadband.

Figure 5-1. Travel Alert Deadband

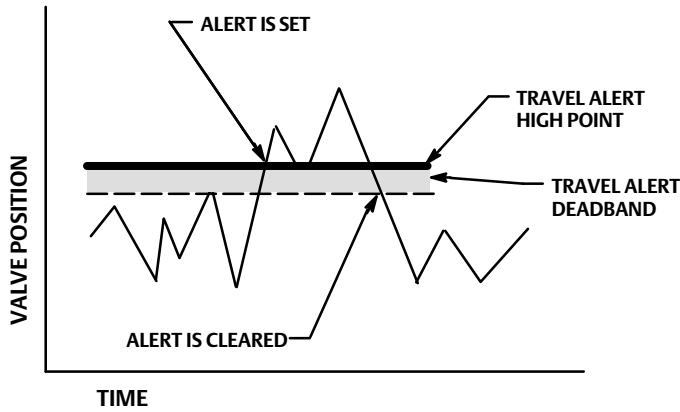

A6532

The Cycle Counter and Travel Accumulator Deadband applies to both the Cycle Count High Alert and the Travel Accumulator High Alert. The deadband establishes a zone around a travel reference point. The travel reference point gets reestablished to the point of travel reversal that occurs outside of the deadband. The deadband must be exceeded before a change in travel direction will be counted as a cycle and the accumulated travel (up to the point of travel reversal) is added to the total accumulation. See figure 5-2.

Figure 5-2. Cycle Counter and Travel Accumulator Deadband Example (set at 10%)

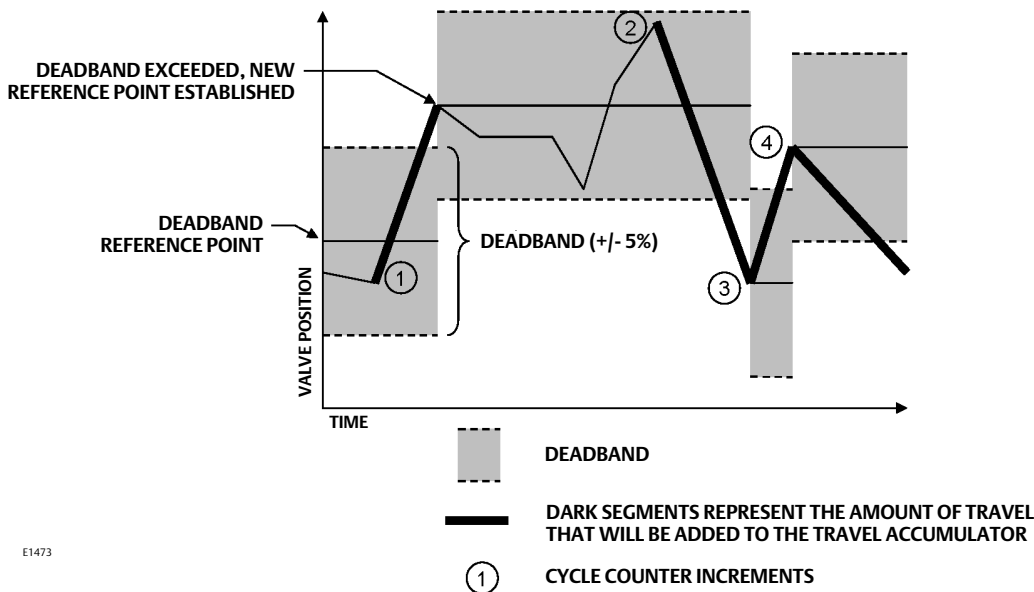

E1473

Diagnostics

⚠ WARNING

During stroke valve, partial stroke, and demand mode tests the valve will move. To avoid personal injury and property damage caused by the release of pressure or process fluid, when used in an application where the valve is normally closed, provide some temporary means of control for the process.

Stroke Valve

Follow the prompts on the Device Communicator display to select from the following:

- **Done**—Select this if you are done. All ramping is stopped when DONE is selected.
- **Ramp Open**—ramps the travel toward open at the rate of 1.0% per second of the ranged travel.
- **Ramp Closed**—ramps the travel toward closed at the rate of 1.0% per second of the ranged travel.
- **Ramp to Target**—ramps the travel to the specified target at the rate of 1.0% per second of the ranged travel.
- **Step to Target**—steps the travel to the specified target.

Partial Stroke Test

There are multiple ways that a partial stroke test can be initiated with the DVC6200 SIS.

- **Automatic (Scheduled)**

The Auto Partial Stroke Test allows the partial stroke test to be scheduled by the DVC6200 SIS. The test is scheduled in number of hours between tests. Any power cycle will reset the test clock timer.

- **Local Pushbutton**

A partial stroke test command may be sent to the digital valve controller using a set of contacts wired to the auxiliary +/- terminals. To perform a test, the contacts must be closed for 3 to 10 seconds and then opened. To abort the test, close the contacts for 1 second. The last set of diagnostic data is stored in the instrument memory for later retrieval via ValveLink software.

- **Local Control Panel**

The LCP100 or LPC200 local control panel is wired directly to the DVC6200 SIS digital valve controller.

The “Valve Test” push button (see figure 5-3) allows the valve to perform the configured partial stroke test.

- Press and hold for 3 to 10 seconds

The test can be overridden by the “Valve Close” button, “Valve Open” button, or if an emergency demand occurs.

Figure 5-3. Local Control Panel



● Device Communicator

1. Connect the Device Communicator to the LOOP terminals on the digital valve controller.
2. Turn on the Device Communicator.
3. From the *Online* menu, select *Service Tools > Diagnostics > Partial Stroke Test*.
4. Select either *Standard (10%)* or *Custom*. With the Custom Stroke Test, the stroke may be entered up to 30% with configurable stroking speed and pause time.
5. The currently configured Stroke, Stroking Speed, and Pause Time is displayed. Choose “Yes” to run the test using these values. Choose “No” to modify the values. The default value for Stroke Speed is 0.25%/second.
6. The valve begins to move and the actual travel reported by the digital valve controller is displayed on the Device Communicator.
7. Once the valve has reached the endpoint, check that the valve has reached the desired set point. The valve should return to its original position.

● ValveLink Software

Run the Partial Stroke diagnostic.

Demand Mode Tests

The following steps assume the use of single acting spring and diaphragm actuators or double-acting spring assist piston actuators.

Perform the following steps to confirm valve operation:

● Point-to-Point Mode (DVC6200 SIS powered with 4-20 mA current source)

If the DVC6200 SIS is in series with a solenoid valve,

1. Disconnect the power from the solenoid valve, but maintain the 20 mA current to the digital valve controller. The valve should move to its “fail safe” position.
2. Maintain power to the solenoid valve and adjust the current to the digital valve controller from 20 mA to 4 mA. The valve should move to its “fail safe” position.
3. Remove power from the solenoid valve and adjust the current to the digital valve controller from 20 mA to 4 mA. The valve should go to its “fail safe” position.

If a solenoid is not used with a DVC6200 SIS,

1. Adjust the current to the digital valve controller from 20 mA to 4 mA. The valve should move to its “fail safe” position.

Note

The above tests are applicable for single-acting direct relay A and C. If single-acting reverse relay B is used adjust the current from 4 mA (normal state) to 20 mA (trip state).

- **Multi-drop Mode (DVC6200 SIS is powered by a 24 VDC power source)**

If the DVC6200 SIS is pneumatically in series with a solenoid valve, and shares a single power source,

1. Disconnect power to both devices. The valve should go to its “fail safe” position.

If the DVC6200 SIS is pneumatically in series with a solenoid valve, with independent power sources,

1. Connect a 24 VDC power supply to the solenoid valve and a second 24 VDC power supply to the DVC6200 SIS.
2. Disconnect the solenoid valve power supply, but maintain the power supply to the DVC6200 SIS. The valve should go to its “fail safe” position quickly.
3. Maintain the power supply to the solenoid valve and disconnect the DVC6200 SIS power supply. The valve should go to its “fail safe” position, although not as quickly as it does in the previous scenario.

If DVC6200 SIS is alone, without a solenoid valve,

1. Disconnect power to the digital valve controller. The valve should go to its “fail safe” position.

Note

The above tests are applicable for single-acting direct relay A and C.

- **If a local control panel is used, conduct the following tests:**

LCP100**Successful Partial Stroke Test**

1. Press the “Valve Test” (black) push button for more than 3 seconds (but less than 10 seconds).
2. Observe that the green light starts flashing when the valve starts moving.
3. Observe that the valve moves no more than the configured PST travel limit.
4. Observe that the valve returns to the normal operating position and the green light comes on solid.

Manually Aborted Partial Stroke Test

1. Press the “Valve Test” (black) push button for more than 3 seconds (but less than 10 seconds).
2. Observe that the green light starts flashing when the valve starts moving.
3. Before the valve reaches the travel limit of the configured partial stroke test, press the “Valve Test” push button, or the push button next to the green light.
4. Observe that the valve immediately returns to the normal operating position and the green light comes on solid.

Emergency Demand through the Logic Solver

1. Reduce the current to the DVC6200 SIS to 4 mA for de-energize to trip operation.
-

Note

You may remove the power completely; however, the lights in step 3 will be off. Without power to the DVC6200 SIS, the LCP100 cannot function.

2. Observe that the valve moves to its fail safe state.
3. Observe that the red light comes on solid and the yellow light stays off (valve is not ready to open).
4. Press the push button next to the green light and observe that the valve does not move.
5. Increase the current to the DVC6200 SIS to 20 mA and observe that the valve remains in its fail safe state.
6. Observe that the red light stays on solid and the yellow light comes on solid (ready to reset).
7. Press the push button next to the green light.
8. Observe that the green light starts flashing, then becomes solid and the red light is off.

Emergency Demand through Local Control Panel

1. Press the push button next to the red light.
2. Observe that the valve moves to its fail safe position.
3. Observe that the red light starts flashing, then becomes solid and the yellow light comes on solid (ready to reset).
4. Press the push button next to the green light.
5. Observe that the red light goes off, the valve moves to its normal operating position, and the green light comes on solid.

LCP200

Successful Partial Stroke Test

1. Verify that the Top (Green/Normal) light is on solid.
2. Press the Bottom (Test) pushbutton for more than 3 seconds (but less than 10 seconds).
3. Observe that the top light starts flashing when the valve starts moving.
4. Observe that the valve moves no more than the configured partial stroke test travel limit.
5. Observe that the valve returns to the normal operating position and the top light comes on solid.
6. If the relay contacts are being used, verify that the Test contact changes state when the PST is in progress. When the PST is complete verify that the contact returns to the pre-PST state.

Manually Aborted Partial Stroke Test

1. Verify that the Top (Green/Normal) light is on solid.
2. Press the Bottom (Test) pushbutton for more than 3 seconds (but less than 10 seconds).
3. Observe that the top light starts flashing when the valve starts moving.
4. Before the valve reaches the travel limit of the configured partial stroke test, press the Top (Reset) pushbutton or the bottom pushbutton.
5. Observe that the valve immediately returns to the normal operating position and the top light comes on solid and if the contact is being used, the Reset contact changes state for 1.5 to 3 seconds.
6. If the relay contacts are being used, verify that the Test contact changes state when the PST is in progress.

Emergency Demand through the Logic Solver

1. Reduce the current to the DVC6200 SIS to 4 mA (for de-energize to trip operation).

Note

For a loop powered installation, a minimum current of 8 mA is required at the trip state / "Safety Demand" for proper functioning of the pushbuttons and lights.

2. Observe that the valve moves to its Trip state.
3. Observe that the Middle (Red/Trip) light comes on solid and the Bottom (Yellow/Ready-to-Reset) light stays off.
4. Increase the current to the DVC6200 SIS to 20 mA (for de-energize to trip) and observe that the valve behaves as configured in the reset option i.e., Auto, Manual, or Smart Auto. If the configuration is for auto reset, skip steps 5 and 6.
5. Observe that the middle light stays on solid and the bottom light comes on solid (ready to reset).
6. Press the Top (Reset) pushbutton.
7. Observe that the middle and bottom lights go off, the valve moves to its normal operating position, and then the Top (Green/Normal) light comes on solid.
8. If the relay contacts are being used, verify that the Reset contact changes state for 1.5 to 3 seconds when the top pushbutton is pressed.

Emergency Demand and Reset through Local Control Panel

1. Press the Middle (Trip) pushbutton.
2. Observe that the valve moves to it Trip position.
3. Observe that the Middle (Red/Trip) light comes on solid and the Bottom (Yellow/Ready-to-Reset) light is on solid.
4. If the relay contacts are being used, verify that the Trip contact changes state for 1.5 to 3 seconds when the middle pushbutton is pressed.
5. Press the Top (Reset) pushbutton.
6. Observe that the middle light goes off, the valve moves to its normal operating position, and then the Top (Green/Normal) light comes on solid.
7. If the relay contacts are being used, verify that the Reset contact changes state for 1.5 to 3 seconds when the top pushbutton is pressed.

Solenoid Valve Health Monitoring

Solenoid valve health monitoring requires the following setup:

- Single-acting actuator
- Solenoid valve installed between the DVC6200 SIS pressure output and the actuator
- Unused output pressure port of the DVC6200 SIS connected between the solenoid and the actuator, close to the actuator
- Relay configured as “special application”
- Output terminal configured as “Limit Switch” (only required when the solenoid valve is wired in series with the DVC6200 SIS)

If the solenoid valve is wired directly to the logic solver, the following steps can be used to test the solenoid valve.

1. Momentarily interrupt the power to the solenoid valve through the Logic Solver (typically 100 to 200 milliseconds). The duration of the interruption should be short enough so that the safety valve travel does not move, but long enough to so that a pressure drop across the solenoid valve is detected.
2. Properly configured, data collection will occur automatically and will be stored onboard the DVC6200 SIS.
3. With ValveLink software, upload the diagnostic data from the triggered profile menu.
4. Examine the graph and observe that there was a change in the pressure reading downstream of the solenoid.

If the solenoid valve is wired in series with the DVC6200 SIS and logic solver, the following steps can be used to test the solenoid valve.

1. With ValveLink software, run the Solenoid Valve Test diagnostic. When configured correctly, the DVC6200 SIS will conduct the power interruption and collect the data.
2. Examine the graph and observe that there was a change in the pressure reading downstream of the solenoid.

Variables

Device Communicator	Service Tools > Variables (3-4)
---------------------	---------------------------------

The Variables section provides current values of the instrument variables. Below is a list of the variables available for viewing:

- Write Protection (also provides a procedure to enable/disable)
- Instrument Mode (also provides a procedure to place in/out of service)
- Analog Input
- Setpoint
- Travel
- Drive Signal
- Input Characterization (also provides a procedure to modify)
- Cycle Counter

- Travel Accumulator
- Supply Pressure
- Actuator Pressure(s)
- Instrument Temperature
- Travel Counts (this is the raw travel sensor reading used for advanced adjustments)
- Maximum Recorded Temperature
- Minimum Recorded Temperature
- Number of Power Ups
- Days Powered Up

Section 6 Maintenance and Troubleshooting

The DVC6200 SIS digital valve controller enclosure is rated Type 4X and IP66, therefore periodic cleaning of internal components is not required. If the DVC6200 SIS is installed in an area where the exterior surfaces tend to get heavily coated or layered with industrial or atmospheric contaminants, it is recommended that the vent (key 52) be periodically removed and inspected to ensure there is no partial or full obstruction. If the vent appears to be partially or fully obstructed, it must be cleaned or replaced. Lightly brush the exterior of the vent to remove contaminants and run a mild water/detergent solution through the vent to ensure it is free of any obstruction. Allow the vent to dry before reinstalling.

⚠ WARNING

Personal injury or property damage can occur from cover failure due to overpressure. Ensure that the housing vent opening is open and free of debris to prevent pressure buildup under the cover.

⚠ WARNING

To avoid static discharge from the plastic cover when flammable gases or dust are present, do not rub or clean the cover with solvents. To do so could result in a spark that may cause the flammable gases or dust to explode, resulting in personal injury or property damage. Clean with a mild detergent and water only.

⚠ WARNING

Avoid personal injury or property damage from sudden release of process pressure or bursting of parts. Before performing any maintenance procedures on the DVC6200 SIS digital valve controller:

- Always wear protective clothing, gloves, and eyewear.
- Do not remove the actuator from the valve while the valve is still pressurized.
- Disconnect any operating lines providing air pressure, electric power, or a control signal to the actuator. Be sure the actuator cannot suddenly open or close the valve.
- Use bypass valves or completely shut off the process to isolate the valve from process pressure. Relieve process pressure from both sides of the valve.
- Use lock-out procedures to be sure that the above measures stay in effect while you work on the equipment.
- Check with your process or safety engineer for any additional measures that must be taken to protect against process media.
- Vent the pneumatic actuator loading pressure and relieve any actuator spring precompression so the actuator is not applying force to the valve stem; this will allow for the safe removal of the stem connector.

⚠ WARNING

When using natural gas as the supply medium, or for explosion proof applications, the following warnings also apply:

- Remove electrical power before removing the housing cap. Personal injury or property damage from fire or explosion may result if power is not disconnected before removing the cap.
- Remove electrical power before disconnecting any of the pneumatic connections.

- When disconnecting any of the pneumatic connections or any pressure retaining part, natural gas will seep from the unit and any connected equipment into the surrounding atmosphere. Personal injury or property damage may result from fire or explosion if natural gas is used as the supply medium and appropriate preventive measures are not taken. Preventive measures may include, but are not limited to, one or more of the following: ensuring adequate ventilation and the removal of any ignition sources.
- Ensure that the cover is correctly installed before putting this unit back into service. Failure to do so could result in personal injury or property damage from fire or explosion.

CAUTION

When replacing components, use only components specified by the factory. Always use proper component replacement techniques, as presented in this manual. Improper techniques or component selection may invalidate the approvals and the product specifications, as indicated in table 1-1, and may also impair operations and the intended function of the device.

Because of the diagnostic capability of the DVC6200 SIS, predictive maintenance is available through the use of ValveLink software. Using the digital valve controller, valve and instrument maintenance can be enhanced, thus avoiding unnecessary maintenance. For information on using ValveLink software, refer to the ValveLink software online help.

Removing the Magnetic Feedback Assembly

To remove the magnet assembly from the actuator stem, perform the following basic steps.

1. Make sure that the valve is isolated from the process.
2. Remove the instrument terminal box cover.
3. Disconnect the field wiring from the terminal board.
4. Shut off the instrument air supply.
5. Disconnect the pneumatic tubing and remove the DVC6200 SIS or the DVC6215 from the actuator.
6. Remove the screws holding the magnet assembly to the connector arm.

When replacing the instrument, be sure to follow the mounting guidelines in the quick start guide ([D103556X012](#)) that shipped with the digital valve controller. Setup and calibrate the instrument prior to returning to service.

Module Base Maintenance

The digital valve controller contains a module base consisting of the I/P converter, printed wiring board assembly, and pneumatic relay. The module base may be easily replaced in the field without disconnecting field wiring or tubing.

Tools Required

Table 6-1 lists the tools required for maintaining the DVC6200 SIS digital valve controller.

Table 6-1. Tools Required

Tool	Size	Component
Phillips Screwdriver		Relay, printed wiring board assembly, and cover screws
Hex key	5 mm	Terminal box screw
Hex key	1.5 mm	Terminal box cover screw
Hex key	2.5 mm	I/P converter screws
Hex key	6 mm	Module base screws

Component Replacement

When replacing any of the components of the DVC6200 SIS, the maintenance should be performed in an instrument shop whenever possible. Make sure that the electrical wiring and pneumatic tubing is disconnected prior to disassembling the instrument.

Removing the Module Base

Refer to figure 7-2 or 7-4 for key number locations.

⚠ WARNING

To avoid personal injury or equipment damage from bursting of parts, turn off the supply pressure to the digital valve controller and bleed off any excess supply pressure before attempting to remove the module base assembly from the housing.

1. Unscrew the four captive screws in the cover (key 43) and remove the cover from the module base (key 2).
2. Using a 6 mm hex socket wrench, loosen the three-socket head screws (key 38). These screws are captive in the module base by retaining rings (key 154).

Note

The module base is linked to the housing by two cable assemblies. Disconnect these cable assemblies after you pull the module base out of the housing.

3. Pull the module base straight out of the housing (key 1). Once clear of the housing, swing the module base to the side of the housing to gain access to the cable assemblies.
4. The digital valve controller/base unit has two cable assemblies, shown in figure 6-1, which connect the module base, via the printed wiring board assembly, travel sensor and the terminal box. Disconnect these cable assemblies from the printed wiring board assembly on the back of the module base.

Figure 6-1. Printed Wiring Board Cable Connections

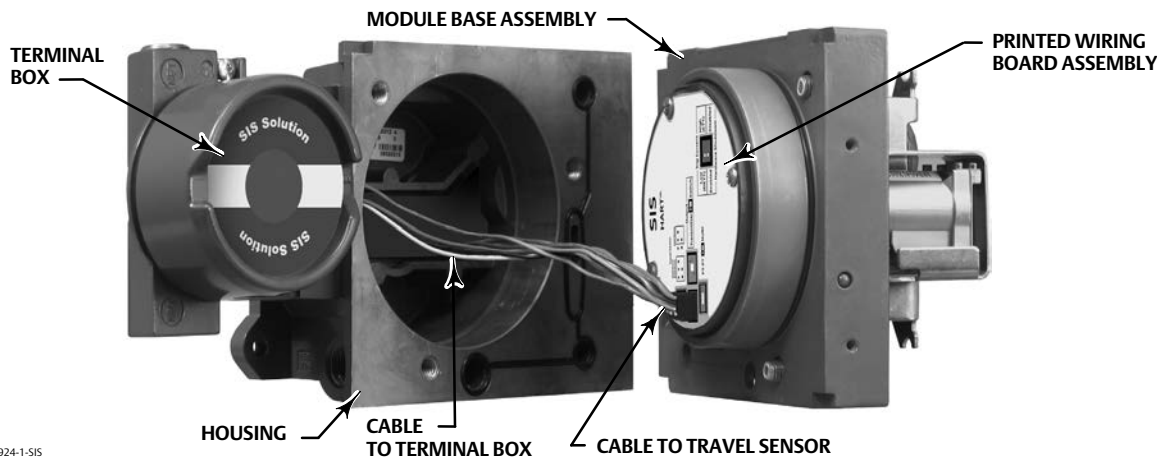

W9924-1-SIS

Replacing the Module Base

Refer to figure 7-2 or 7-4 for key number locations.

CAUTION

To avoid affecting performance of the instrument, take care not to damage the module base seal or guide surface. Do not bump or damage the bare connector pins on the PWB assembly. Damaging either the module base or guide surface may result in material damage, which could compromise the instruments ability to maintain a pressure seal.

Note

To avoid affecting performance of the instrument, inspect the guide surface on the module and the corresponding seating area in the housing before installing the module base assembly. These surfaces must be free of dust, dirt, scratches, and contamination.

Ensure the module base seal is in good condition. Do not reuse a damaged or worn seal.

1. Ensure the module base seal (key 237) is properly installed in the housing (key 1). Ensure the O-ring (key 12) is in place on the module base assembly.
2. Connect the travel sensor and terminal box cable assemblies to the PWB assembly (key 50). Orientation of the connector is required.
3. Insert the module base (key 2) into the housing (key 1).

Note

For stainless steel digital valve controllers pipe thread sealant (key 64) is recommended under the head of the three socket head screws (key 38) prior to attaching the module base to the housing in the next step.

4. Install three socket head screws (key 38) in the module base into the housing. If not already installed, press three retaining rings (key 154) into the module base. Evenly tighten the screws in a crisscross pattern to a final torque of 16 N•m (138 lbf•in).

⚠ WARNING

Personal injury, property damage, or disruption of process control can result if the cable assemblies/wiring are damaged when attaching the cover to the module base assembly

Ensure that the cable assemblies/wiring are positioned in the cavity of the module base so they do not get compressed or damaged when attaching the cover to the module base assembly in step 5.

5. Attach the cover (key 43) to the module base assembly.

Submodule Maintenance

The module base of the DVC6200 SIS contains the following submodules: I/P converter, PWB assembly, and pneumatic relay. If problems occur, these submodules may be removed from the module base and replaced with new submodules. After replacing a submodule, the module base may be put back into service.

CAUTION

Exercise care when performing maintenance on the module base. Reinstall the cover to protect the I/P converter and gauges when servicing other submodules.

In order to maintain accuracy specifications, do not strike or drop the I/P converter during submodule maintenance.

I/P Converter

Refer to figure 7-2 or 7-4 for key number locations. The I/P converter (key 41) is located on the front of the module base.

Note

After I/P converter submodule replacement, calibrate the digital valve controller to maintain accuracy specifications.

Replacing the I/P Filter

A screen in the supply port beneath the I/P converter serves as a secondary filter for the supply medium. To replace this filter, perform the following procedure:

1. Remove the I/P converter (key 41) and shroud (key 169) as described in the Removing the I/P Converter procedure.
2. Remove the screen (key 231) from the supply port.
3. Install a new screen in the supply port as shown in figure 6-2.

Figure 6-2. I/P Filter Location

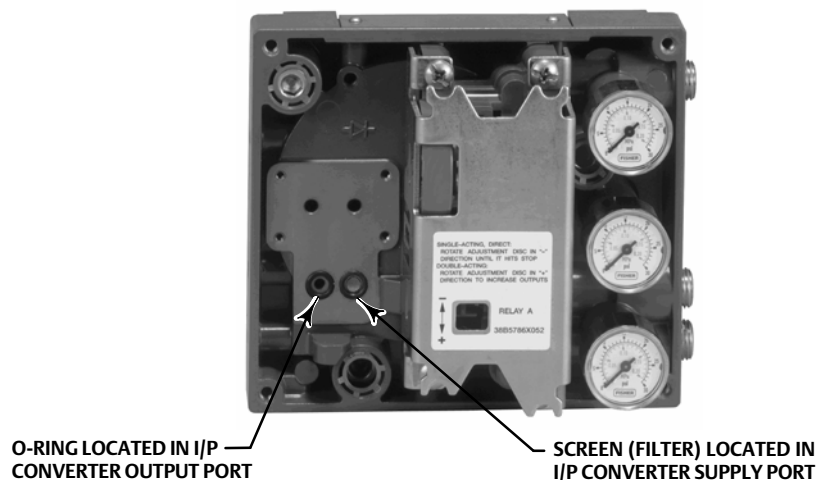

W8072

4. Inspect the O-ring (key 39) in the I/P output port. Replace if necessary.
5. Reinstall the I/P converter (key 41) and shroud (key 169) as described in the Replacing the I/P Converter procedure.

Removing the I/P Converter

1. Remove the front cover (key 43), if not already removed.
2. Refer to figure 6-3. Using a 2.5 mm hex socket wrench, remove the four socket-head screws (key 23) that attach the shroud (key 169) and I/P converter (key 41) to the module base (key 2).
3. Remove the shroud (key 169); then pull the I/P converter (key 41) straight out of the module base (key 2). Be careful not to damage the two electrical leads that come out of the base of the I/P converter.
4. Ensure that the O-ring (key 39) and screen (key 231) stay in the module base and do not come out with the I/P converter (key 41).

Replacing the I/P Converter

1. Refer to figure 6-2. Inspect the condition of the O-ring (key 39) and screen (key 231) in the module base (key 2). Replace them, if necessary. Apply silicone lubricant to the O-rings.
2. Ensure the two boots (key 210) shown in figure 6-3 are properly installed on the electrical leads.

Figure 6-3. I/P Converter

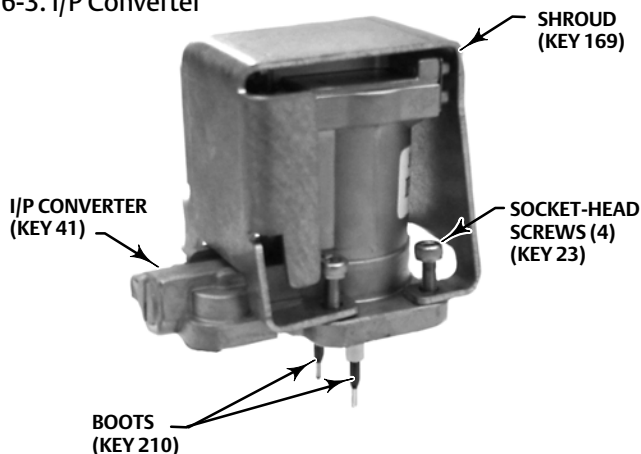

W9328

3. Install the I/P converter (key 41) straight into the module base (key 2), taking care that the two electrical leads feed into the guides in the module base. These guides route the leads to the printed wiring board assembly submodule.
4. Install the shroud (key 169) over the I/P converter (key 41).
5. Install the four socket-head screws (key 23) and evenly tighten them in a crisscross pattern to a final torque of 1.6 N•m (14 lbf•in).
6. After replacing the I/P converter, calibrate travel or perform touch-up calibration to maintain accuracy specifications.

Printed Wiring Board (PWB) Assembly

Refer to figure 7-2 or 7-4 for key number locations. The PWB assembly (key 50) is located on the back of the module base assembly (key 2).

Note

If the PWB assembly submodule is replaced, calibrate and configure the digital valve controller to maintain accuracy specifications.

Removing the Printed Wiring Board Assembly

1. Separate the module base from the housing by performing the Removing the Module Base procedure.
2. Remove three screws (key 33).
3. Lift the PWB assembly (key 50) straight out of the module base (key 2).
4. Ensure that the O-rings (key 40) remain in the pressure sensor bosses on the module base assembly (key 2) after the PWB assembly (key 50) has been removed.

Replacing the Printed Wiring Board Assembly and Setting the DIP Switch

1. Apply silicone lubricant to the pressure sensor O-rings (key 40) and install them on the pressure sensor bosses in the module base assembly.
2. Properly orient the PWB assembly (key 50) as you install it into the module base. The two electrical leads from the I/P converter (key 41) must guide into their receptacles in the PWB assembly and the pressure sensor bosses on the module base must fit into their receptacles in the PWB assembly.
3. Push the PWB assembly (key 50) into its cavity in the module base.
4. Install and tighten three screws (key 33) to a torque of 1 N•m (10.1 lbf•in).
5. Set the DIP switch on the PWB assembly according to table 6-2.

Table 6-2. DIP Switch Configuration⁽¹⁾

Switch Label	Operational Mode	DIP Switch Position
PT-PT	4-20 mA Point-to-Point Loop	LEFT
Multi	24 VDC Multi-Drop Loop	RIGHT
Hardware Shutdown	Enabled	LEFT
Hardware Shutdown	Disabled	RIGHT
Trip Current Low (DETT)	De-energize to trip	LEFT
Trip Current High (ETT)	Energize to trip	RIGHT

1. Refer to figure 6-4 for switch location.

Note

DVC6200 SIS instruments in PT-PT mode require the Hardware Shutdown Switch be Enabled for FMEDA failure rates to be valid for 4-20 mA operation.

Figure 6-4. Printed Wiring Board (PWB) Connections and Settings

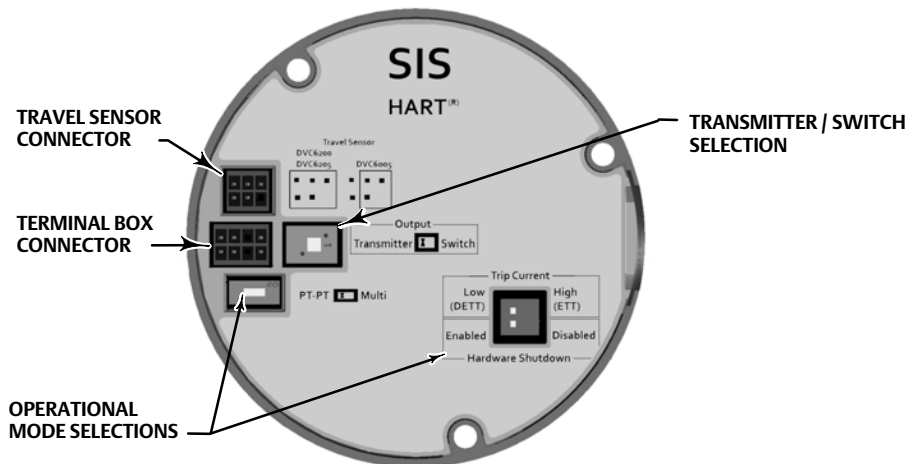

X0436

6. Reassemble the module base to the housing by performing the Replacing the Module Base procedure.
7. Setup and calibrate the digital valve controller.

Pneumatic Relay

Refer to figure 7-2 or 7-4 for key number locations. The pneumatic relay (key 24) is located on the front of the module base.

Note

After relay submodule replacement, calibrate the digital valve controller to maintain accuracy specifications.

Removing the Pneumatic Relay

1. Loosen the four screws that attach the relay (key 24) to the module base. These screws are captive in the relay.
2. Remove the relay.

Replacing the Pneumatic Relay

1. Visually inspect the holes in the module base to ensure they are clean and free of obstructions. If cleaning is necessary, do not enlarge the holes.
2. Apply silicone lubricant to the relay seal and position it in the grooves on the bottom of the relay as shown in figure 6-5. Press small seal retaining tabs into retaining slots to hold relay seal in place.

Figure 6-5. Pneumatic Relay Assembly



3. Position the relay (with shroud) on the module base. Tighten the four screws, in a crisscross pattern, to a final torque of 2 N•m (20.7 lbf•in).
4. Using the Device Communicator, verify that the value for Relay Type parameter matches the relay type installed.
5. After replacing the relay and verifying the relay type, calibrate travel or perform touch-up calibration to maintain accuracy specifications

Gauges, Pipe Plugs, or Tire Valves

Depending on the options ordered, the DVC6200 SIS or DVC6205 SIS will be equipped with either gauges (key 47), pipe plugs (key 66), or tire valves (key 67). Single-acting instruments will also have a screen (key 236, figure 7-3). These are located on the top of the module base next to the relay.

Perform the following procedure to replace the gauges, tire valves, or pipe plugs. Refer to figure 7-2 and 7-3 for key number locations.

1. Remove the front cover (key 43).
2. Remove the gauge, pipe plug, or tire valve as follows:

For gauges (key 47), the flats are on the gauge case. Use a wrench on the flats of the gauge to remove the gauge from the module base. For double-acting instruments, to remove the supply gauge remove one of the output gauges.

For pipe plugs (key 66) and tire valves (key 67), use a wrench to remove these from the module base.

3. Apply pipe thread sealant (key 64) to the threads of the replacement gauges, pipe plugs, or tire valves.
4. Using a wrench, screw the gauges, pipe plugs, or tire valves into the module base.

Terminal Box

Refer to figure 7-2 or 7-4 for key number locations.

The terminal box is located on the housing and contains the terminal strip assembly for field wiring connections.

Note

The DVC6205 SIS feedback connections terminal box (shown to the right in figure 6-6) is not a replaceable part. Do not remove the tamper proof paint on the screw.

Figure 6-6. Terminal Boxes

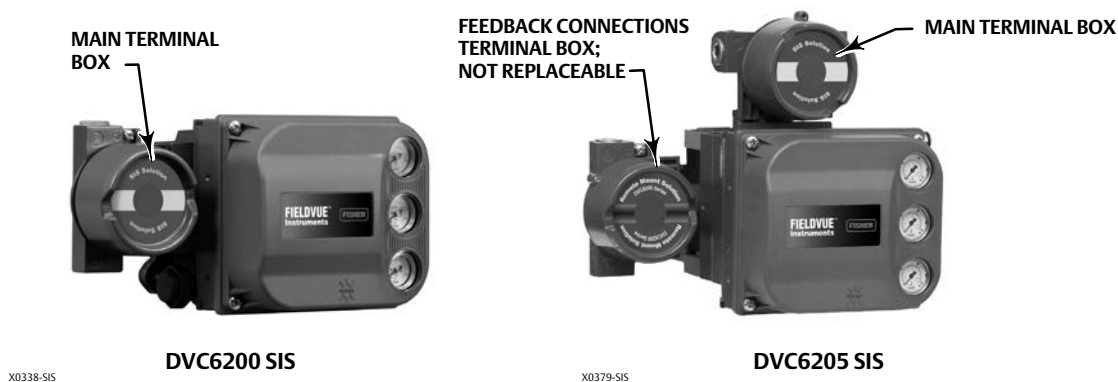

Removing the Terminal Box

⚠ WARNING

To avoid personal injury or property damage caused by fire or explosion, remove power to the instrument before removing the terminal box cover in an area which contains a potentially explosive atmosphere or has been classified as hazardous.

1. Loosen the set screw (key 58) in the cap (key 4) so that the cap can be unscrewed from the terminal box.
2. After removing the cap (key 4), note the location of field wiring connections and disconnect the field wiring from the terminal box.
3. Separate the module base from the housing by performing the Removing the Module Base procedure.
4. Disconnect the terminal box wiring connector from the PWB assembly (key 50).
5. Remove the screw (key 72). Pull the terminal box assembly straight out of the housing.

Replacing the Terminal Box

Note

Inspect all O-rings for wear and replace as necessary.

1. Apply lubricant, silicone sealant to the O-ring (key 34) and install the O-ring over the stem of the terminal box.
2. Insert the terminal box assembly stem into the housing until it bottoms out. Position the terminal box assembly so that the hole for the screw (key 72) in the terminal box aligns with the threaded hole in the housing. Install the screw (key 72).
3. Connect the terminal box wiring connector to the PWB assembly (key 50). Orientation of the connector is required.
4. Reassemble the module base to the housing by performing the Replacing the Module Base procedure.
5. Reconnect the field wiring as noted in step 2 in the Removing the Terminal Box procedure.

6. Apply lubricant, silicone sealant to the O-ring (key 36) and install the O-ring over the 2-5/8 inch threads of the terminal box. Use of a tool is recommended to prevent cutting the O-ring while installing it over the threads.
7. Apply lithium grease (key 63) to the 2-5/8 inch threads on the terminal box to prevent seizing or galling when the cap is installed.
8. Screw the cap (key 4) onto the terminal box until no gap remains.
9. Install the set screw (key 58) into the cap (key 4). Secure the cap by engaging the set screw.

Troubleshooting

If communication or output difficulties are experienced with the instrument, refer to the troubleshooting chart in table 6-3. Also see the DVC6200 SIS Technical Support Checklist on page 74.

Checking Voltage Available

⚠ WARNING

Personal injury or property damage caused by fire or explosion may occur if this test is attempted in an area which contains a potentially explosive atmosphere or has been classified as hazardous.

To check the Voltage Available at the instrument, perform the following:

1. Connect the equipment in figure 2-2 to the field wiring in place of the FIELDVUE instrument.
2. Set the control system to provide maximum output current.
3. Set the resistance of the 1 kilohm potentiometer shown in figure 2-2 to zero.
4. Record the current shown on the milliammeter.
5. Adjust the resistance of the 1 kilohm potentiometer until the voltage read on the voltmeter is 10.0 volts.
6. Record the current shown on the milliammeter.
7. If the current recorded in step 6 is the same as that recorded in step 4 (± 0.08 mA), the voltage available is adequate.
8. If the voltage available is inadequate, refer to Wiring Practices in the Installation section.

Restart Processor

This is a “soft” reset of the device. This procedure can only be performed while the instrument is out of service. A soft reset will immediately put into effect changes that have been sent to the instrument. Also, if the device is configured to shutdown on an alert, the soft reset will clear the shutdown.

Table 6-3. Instrument Troubleshooting

Symptom	Possible Cause	Action
1. Analog input reading at instrument does not match actual current provided.	1a. Control mode not Analog.	1a. Check the control mode using the Device Communicator. If in the Digital or Test mode, the instrument receives its set point as a digital signal. Control is not based on input current. Change Control Mode to Analog.
	1b. Low control system compliance voltage.	1b. Check system compliance voltage (see Wiring Practices in the Installation section).
	1c. Instrument shutdown due to self test failure.	1c. Check instrument status using the Device Communicator (see Viewing Instrument Status in the Viewing Device Information section).
	1d. Analog input sensor not calibrated.	1d. Calibrate the analog input sensor (see Analog Input Calibration in the Calibration section).
	1e. Current leakage.	1e. Excessive moisture in the terminal box can cause current leakage. Typically the current will vary randomly if this is the case. Allow the inside of the terminal box to dry, then retest.
2. Instrument will not communicate.	2a. Insufficient Voltage Available.	2a. Calculate Voltage Available (see Wiring Practices in the Installation section). Voltage Available should be greater than or equal to 10 VDC.
	2b. Controller output Impedance too low.	2b. Install a HART filter after reviewing Control System Compliance Voltage requirements (see Wiring Practices in the Installation section).
	2c. Cable capacitance too high.	2c. Review maximum cable capacitance limits (see Wiring Practices in the Installation section).
	2d. HART filter improperly adjusted.	2d. Check filter adjustment (see the appropriate HART filter instruction manual).
	2e. Improper field wiring.	2e. Check polarity of wiring and integrity of connections. Make sure cable shield is grounded only at the control system.
	2f. Controller output providing less than 4 mA to loop.	2f. Check control system minimum output setting, which should not be less than 3.8 mA.
	2g. Disconnected loop wiring cable at PWB.	2g. Verify connectors are plugged in correctly.
	2h. PWB DIP switch not set properly.	2h. Check for incorrect setting or broken DIP switch on the back of the PWB. Reset switch or replace PWB, if switch is broken. See table 6-2 for switch setting information
	2j. PWB failure.	2j. Use a 4-20 mA current source to apply power to the instrument. Terminal voltage across the LOOP+ and LOOP- terminals should be 8.0 to 9.5 VDC. If the terminal voltage is not 8.0 to 9.5 VDC, replace the PWB.
	2k. Polling address incorrect.	2k. Use the Device Communicator to set the polling address (refer to the Detailed Setup section). From the <i>Utility</i> menu, select <i>Configure Communicator > Polling > Always Poll</i> . Set the instrument polling address to 0.
	2l. Defective terminal box.	2l. Check continuity from each screw terminal to the corresponding PWB connector pin. If necessary, replace the terminal box assembly.
	2m. Defective Device Communicator or ValveLink modem cable.	2m. If necessary, repair or replace cable.
	2n. ValveLink modem defective or not compatible with PC.	2n. Replace ValveLink modem.
	2p. ValveLink hardlock defective or not programmed.	2p. Replace if defective or return to factory for programming.

-continued-

Table 6-3. Instrument Troubleshooting (continued)

Symptom	Possible Cause	Action
3. Instrument will not calibrate, has sluggish performance or oscillates.	3a. Configuration errors.	3a. Verify configuration: If necessary, set protection to None. If Out of Service, place In Service. Check: Travel Sensor Motion Tuning set Zero Power Condition Feedback Connection Control mode (should be Analog) Restart control mode (should be Analog)
	3b. Restricted pneumatic passages in I/P converter.	3b. Check screen in I/P converter supply port of the module base. Replace if necessary. If passages in I/P converter restricted, replace I/P converter.
	3c. O-ring(s) between I/P converter ass'y missing or hard and flattened losing seal.	3c. Replace O-ring(s).
	3d. I/P converter ass'y damaged/corroded/clogged.	3d. Check for bent flapper, open coil (continuity), contamination, staining, or dirty air supply. Coil resistance should be between 1680 - 1860 ohms. Replace I/P assembly if damaged, corroded, clogged, or open coil.
	3e. I/P converter ass'y out of spec.	3e. I/P converter ass'y nozzle may have been adjusted. Verify drive signal (55 to 80% for double-acting; 60 to 85% for single-acting) with the valve off the stops. Replace I/P converter assembly if drive signal is continuously high or low.
	3f. Defective module base seal.	3f. Check module base seal for condition and position. If necessary, replace seal.
	3g. Defective relay.	3g. Depress relay beam at adjustment location in shroud, look for increase in output pressure. Remove relay, inspect relay seal. Replace relay seal or relay if I/P converter assembly is good and air passages not blocked. Check relay adjustment.
	3h. Defective 67CFR regulator, supply pressure gauge jumps around.	3h. Replace 67CFR regulator.
4. ValveLink diagnostic tests provide erroneous results.	4a. Defective pressure sensor.	4a. Replace PWB.
	4b. Pressure sensor O-ring missing.	4b. Replace O-ring.
5. Device Communicator does not turn on.	5a. Battery pack not charged.	5a. Charge battery pack. Note: Battery pack can be charged while attached to the Device Communicator or separately. The Device Communicator is fully operable while the battery pack is charging. Do not attempt to charge the battery pack in a hazardous area.

DVC6200 SIS Technical Support Checklist

Have the following information available prior to contacting your [Emerson sales office](#) for support.

1. Instrument serial number as read from nameplate _____
2. Is the digital valve controller responding to the control signal? Yes _____ No _____
If not, describe _____
3. Measure the voltage across the “Loop -” and Loop +” terminal box screws when the commanded current is 4.0 mA and 20.0 mA: _____ V @ 4.0 mA _____ V @ 20.0 mA.
(These values should be around 8.6 V @ 4.0 mA and 8.8 V @ 20 mA).
4. Is it possible to communicate via HART to the digital valve controller? Yes _____ No _____
5. What is the firmware version of the digital valve controller? _____
6. What is the hardware version of the digital valve controller? _____
7. Is the digital valve controller's Instrument Mode “In Service”? Yes _____ No _____
8. Is the digital valve controller's Control Mode set to “Analog”? Yes _____ No _____
9. What are the following parameter readings?
Input Signal _____ Drive Signal _____ %
Supply Pressure _____ Pressure A _____ Pressure B _____
Travel Target _____ % Travel _____ %
10. What are the following alert readings?
Fail alerts _____
Valve alerts _____
Operational status _____
Alert event record entries _____
11. Export ValveLink data (if available) for the device (Status Monitor, Detailed Setup, etc.).

Mounting

1. Which digital valve controller do you have? DVC6200 SIS _____ DVC6205 SIS/DVC6215 _____
2. What Make, Brand, Style, Size, etc. actuator is the DVC6200 SIS mounted on? _____
3. What is the full travel of the valve? _____
4. What is the Mounting Kit part number? _____
5. If mounting kits are made by LBP/Customer, please provide pictures of installation.
6. Is the Mounting kit installed per the instructions? Yes _____ No _____
7. What is the safe position of the valve? Fail closed _____ Fail open _____

Section 7 Parts

Parts Ordering

Whenever corresponding with your [Emerson sales office](#) about this equipment, always mention the controller serial number.

⚠ WARNING

Use only genuine Fisher replacement parts. Components that are not supplied by Emerson should not, under any circumstances, be used in any Fisher instrument. Use of components not supplied by Emerson may void your warranty, might adversely affect the performance of the instrument, and could cause personal injury and property damage.

Parts Kits

Note

All DVC6200 SIS parts kits with elastomers include extreme temperature fluorosilicone elastomers.

Kit	Description	Part Number
1*	Elastomer Spare Parts Kit (kit contains parts to service one digital valve controller)	19B5402X022
2*	Small Hardware Spare Parts Kit (kit contains parts to service one digital valve controller)	19B5403X012
3*	Seal Screen Kit [kit contains 25 seal screens (key 231) and 25 O-rings (key 39)]	14B5072X182
4*	Integral Mount Seal Kit (for 667 size 30i - 76i and GX actuators) [kit contains 5 seals (key 288)]	19B5402X032
5*	Terminal Box Kit (see figure 7-1)	

Note

Use only with replace in-kind. The following terminal boxes are compatible only with PWB Assembly electronics hardware revision 2 (HW2).

	Aluminum with I/O Package	19B5401X552
	with I/O Package, M20	19B5401X582
	Stainless Steel with I/O Package	19B5401X562
	with I/O Package, M20	19B5401X592
6*	I/P Converter Kit	38B6041X132

*Recommended spare parts

Figure 7-1. Terminal Box

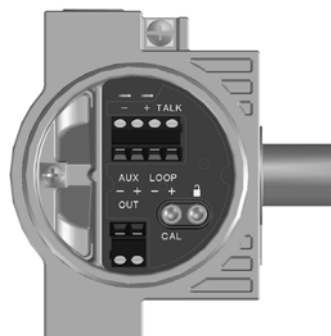

X0430

Key	Description
50*	PWB Assembly (HW2) (see figure 7-2 and 7-4) for DVC6200 SIS and DVC6205 SIS

Note

The following PWB Assembly is compatible only with the terminal box shown in figure 7-1. Contact your Emerson sales office if a replacement PWB is needed.

Hardware Revision 2 (HW2), with I/O Package
For instrument level SIS

Kit	Description	Part Number	Kit	Description	Part Number	
7*	Spare Module Base Assembly Kit [kit contains module base (key 2); drive screws, qty. 2, (key 11); shield/label (key 19); hex socket cap screw, qty. 3, (key 38); self tapping screw, qty. 2 (key 49); pipe plug, qty. 3 (key 61); retaining ring, qty. 3 (key 154); screen (key 236); and flame arrestors, qty. 3 (key 243)]	Aluminum Stainless Steel	GE18654X012 GE18654X022	11*	Feedback Array Kit 50 mm (2-inch) Aluminum Stainless steel 110 mm (4-1/8 inch) Aluminum Stainless steel 210 mm (8-1/4 inch) Aluminum Stainless steel	GG20240X052 GE65853X042 GG20240X082 GE65853X062 GG20243X012 GE65853X072
8*	Spare Housing Assembly Kit [kit contains housing (key 1); vent assembly (key 52); seal (only included in Housing A kits) (key 288); seal (key 237); O-ring (key 34); O-ring (only used with integrally mounted regulator) (key 5)]	Aluminum Housing A (used for GX actuator) Housing B (used for all actuators except GX) Stainless Steel Housing B (used for all actuators except GX)	GE48798X042 GE48798X082 GE48798X102	Rotary [Kit contains feedback assembly, pointer assembly, travel indicator scale and M3 machine pan head screws qty.2]. Stainless steel kits only for use with stainless steel mounting kits.	Aluminum Stainless steel	GG10562X012 GG10562X022
9*	Spare I/P Shroud Kit [kit contains shroud (key 169) and hex socket cap screw, qty. 4 (key 23)]	GE29183X012	Rotary array kit with coupler [Kit contains feedback assembly and NAMUR coupler]	Aluminum Stainless steel	GE71982X012 GE71982X022	
10*	Remote Mount Feedback Unit Kit (see figure 7-5) [remote housing assembly (key 25); hex socket set screw (key 58); 1/2 NPT pipe plug (key 62); wire retainer, qty 2 (key 131); terminal cover (key 255); o-ring (key 256); gasket (Housing A only, used for GX actuator) (key 287); seal (Housing A only, used for GX actuator) (key 288)]		12	Mounting Shield Kit [kit contains shield, qty. 3 and machine screws, qty. 6]	GG05242X022	
			13*	Gasket/Seal Kit, for use with GX actuator [kit contains insulating gasket (key 287) and seal (key 288)]	GE45468X012	

Note

The remote mount feedback kit is not orderable by part number due to nameplate/approval requirements. Contact your [Emerson sales office](#) for information on ordering this kit.

11*	Feedback Array Kit Sliding Stem (Linear) [kit contains • feedback array and hex socket cap screws, qty.2, washer, plain, qty.2, external tooth lock washer, qty.2 (only with aluminum feedback array kit) and alignment template. • 210 mm (8-1/4 inch) kit contains feedback array and hex socket cap screws, qty. 4, washer, plain, qty. 4, external tooth lock washer, qty. 4 (only with aluminum feedback array kit), alignment template and insert]. Stainless steel kits only for use with stainless steel mounting kits.	
	7 mm (1/4-inch) Aluminum	GG20240X012
	19 mm (3/4-inch) Aluminum Stainless steel	GG20240X022 GE65853X012
	25 mm (1-inch) Aluminum Stainless steel	GG20240X032 GE65853X022
	38 mm (1-1/2 inch) Aluminum Stainless steel	GG20240X042 GE65853X032

Parts List

Note

Contact your Emerson sales office for Part Ordering information.

All DVC6200 SIS parts with elastomers include extreme temperature fluorosilicone elastomers.

Parts with footnote numbers shown are available in parts kits; see footnote information at the bottom of the page.

Key	Description
-----	-------------

Housing (see figure 7-2 and 7-4)

DVC6200 SIS and DVC6205 SIS

1	Housing ⁽⁸⁾
11	Drive Screw (2 req'd) (DVC6205 SIS only)
20	Shield (DVC6205 SIS only)
52	Vent ⁽²⁾
74	Mounting Bracket (DVC6205 SIS only)
248	Screw, hex head (4 req'd) (DVC6205 SIS only)
249	Screw, hex head (4 req'd) (DVC6205 SIS only)
250	Spacer (4 req'd) (DVC6205 SIS only)
267	Standoff (2 req'd) (DVC6205 SIS only)
271	Screen ⁽⁸⁾

*Recommended spare parts

2. Available in the Small Hardware Spare Parts Kit
8. Available in the Spare Housing Assembly Kit

Key	Description	Part Number
287	Gasket, Housing A only (used for GX actuator) (DV6200 SIS only)	
288	Seal (used for 667 size 30i - 76i and GX actuators) (DVC6200 SIS only)	

Common Parts (see figure 7-2, 7-3, and 7-4)

DVC6200 SIS and DVC6205 SIS

16*	O-ring ⁽¹⁾ (3 req'd)	
29	Warning label, for use only with LCIE hazardous area classifications	
33	Mach Screw, pan head ⁽²⁾ (3 req'd)	
38	Cap Screw, hex socket ⁽²⁾⁽⁷⁾ (3 req'd)	
43*	Cover Assembly (includes cover screws)	GG53748X022
48	Nameplate	
49	Screw, self tapping (2 req'd) ⁽⁷⁾	
61	Pipe Plug, hex socket ⁽⁷⁾ Housing A with relay C (2 req'd) (used for GX actuator) Housing A with relay B (1 req'd) (used for GX actuator) Housing B with relay B and C (1 req'd) (used for all actuators except GX) Not required for relay A	
63	Lithium grease (not furnished with the instrument)	
64	Pipe thread sealant, anaerobic (not furnished with the instrument)	
65	Lubricant, silicone sealant (not furnished with the instrument)	
154	Retaining Ring ⁽²⁾ (3 req'd)	
236	Screen (required for relay B and C only) ⁽⁸⁾	
237	Module Base Seal ⁽¹⁾	

Module Base (see figure 7-2 and 7-4)

DVC6200 SIS and DVC6205 SIS

2	Module Base ⁽⁷⁾	
11	Drive Screw ⁽⁷⁾ (2 req'd)	
12	O-ring ⁽¹⁾	
19	Shield ⁽⁷⁾	
61	Pipe Plug, hex socket ⁽⁷⁾ (3 req'd)	
243	Slotted Pin (flame arrestor) ⁽⁷⁾ (3 req'd)	

I/P Converter Assembly (see figure 7-2 and 7-4)

DVC6200 SIS and DVC6205 SIS

23	Cap Screw, hex socket ⁽²⁾⁽⁹⁾ (4 req'd)	
39*	O-ring ⁽¹⁾⁽³⁾⁽⁶⁾	
41	I/P Converter ⁽⁶⁾	
169	Shroud ⁽⁶⁾⁽⁹⁾ (see figure 6-3)	
210*	Boot ⁽¹⁾⁽⁶⁾ (2 req'd) (see figure 6-3)	
231*	Seal Screen ⁽¹⁾⁽³⁾⁽⁶⁾	

Relay (see figure 7-2 and 7-4)

DVC6200 SIS and DVC6205 SIS

24*	Relay Assembly, (includes shroud, relay seal, mounting screws)	
	Low Bleed	
	Single-acting direct (relay C)	38B5786X162
	Double-acting (relay A)	38B5786X082
	Single-acting reverse (relay B)	38B5786X122

Loop Connections Terminal Box (see figure 7-2 and 7-4)

DVC6200 SIS and DVC6205 SIS

4	Terminal Box Cap	
34*	O-ring ⁽¹⁾⁽⁵⁾	
36*	O-ring ⁽¹⁾⁽⁵⁾	
58	Set Screw, hex socket ⁽²⁾	
72	Cap Screw, hex socket ⁽²⁾	
164	Terminal Box Assembly	

Feedback Connections Terminal Box (see figure 7-4)

DVC6205 SIS

4	Terminal Box Cap	
34*	O-ring ⁽¹⁾⁽⁵⁾	
36*	O-ring ⁽¹⁾⁽⁵⁾	
58	Set Screw, hex socket ⁽²⁾	
62	Pipe Plug, hex hd	
263*	O-ring	

*Recommended spare parts

1. Available in the Elastomer Spare Parts Kit
2. Available in the Small Hardware Spare Parts Kit
3. Available in the Seal Screen Kit
5. Available in the Terminal Box Kit
6. Available in the I/P Converter Kit
7. Available in the Spare Module Base Assembly Kit
9. Available in the Spare Shroud Kit

Key Description

Pressure Gauges, Pipe Plugs, or Tire Valve Assemblies (see figure 7-3)

DVC6200 SIS and DVC6205 SIS

- 47* Pressure Gauge
 - Double-acting (3 req'd); Single-acting (2 req'd)
 - PSI/MPa Gauge Scale
 - To 60 PSI, 0.4 MPa
 - To 160 PSI, 1.1 MPa
 - PSI/bar Gauge Scale
 - To 60 PSI, 4 bar
 - To 160 PSI, 11 bar
 - PSI/KG/CM² Gauge Scale
 - To 60 PSI, 4 KG/CM²
 - To 160 PSI, 11 KG/CM²

Key Description

- 66 Pipe Plug, hex head
 - For units w/o gauges
- 67 Tire Valve, used with Tire Valve Option only
 - Double-acting (3 req'd); Single-acting (2 req'd)

DVC6215 Feedback Unit (see figure 7-5)

- 65 Lubricant, silicone sealant (not furnished with the instrument)
- 256* O-Ring

HART Filter

HF340, DIN rail mount

Line Conditioner

LC340 Line Conditioner

Figure 7-2. FIELDVUE DVC6200 SIS Digital Valve Controller Housing Assembly

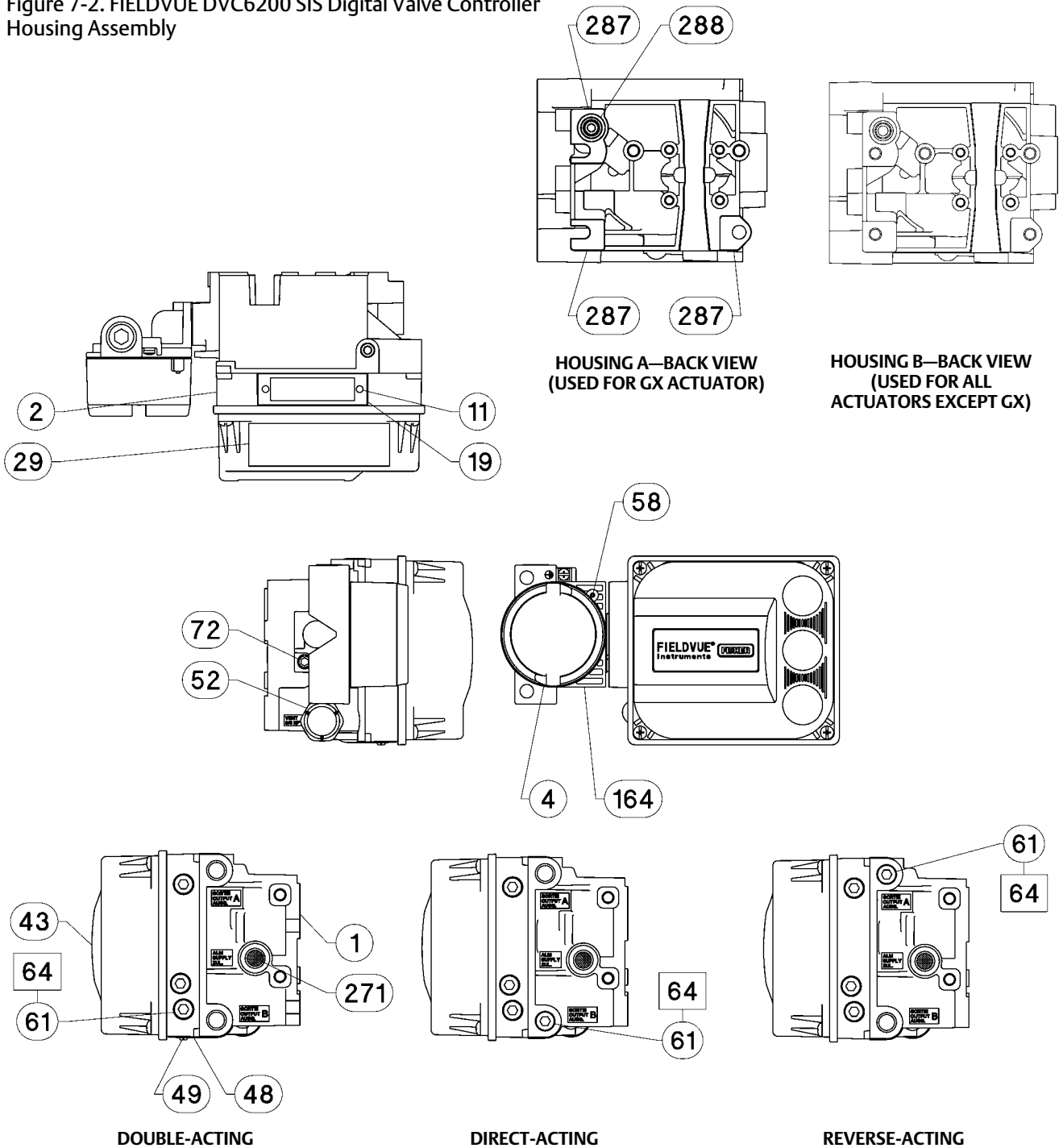

- APPLY LUBRICANT, SEALANT, OR THREAD LOCK
- 65 APPLY LUBRICANT ON ALL O-RINGS UNLESS OTHERWISE SPECIFIED

Figure 7-2. FIELDVUE DVC6200 SIS Digital Valve Controller Housing Assembly (continued)

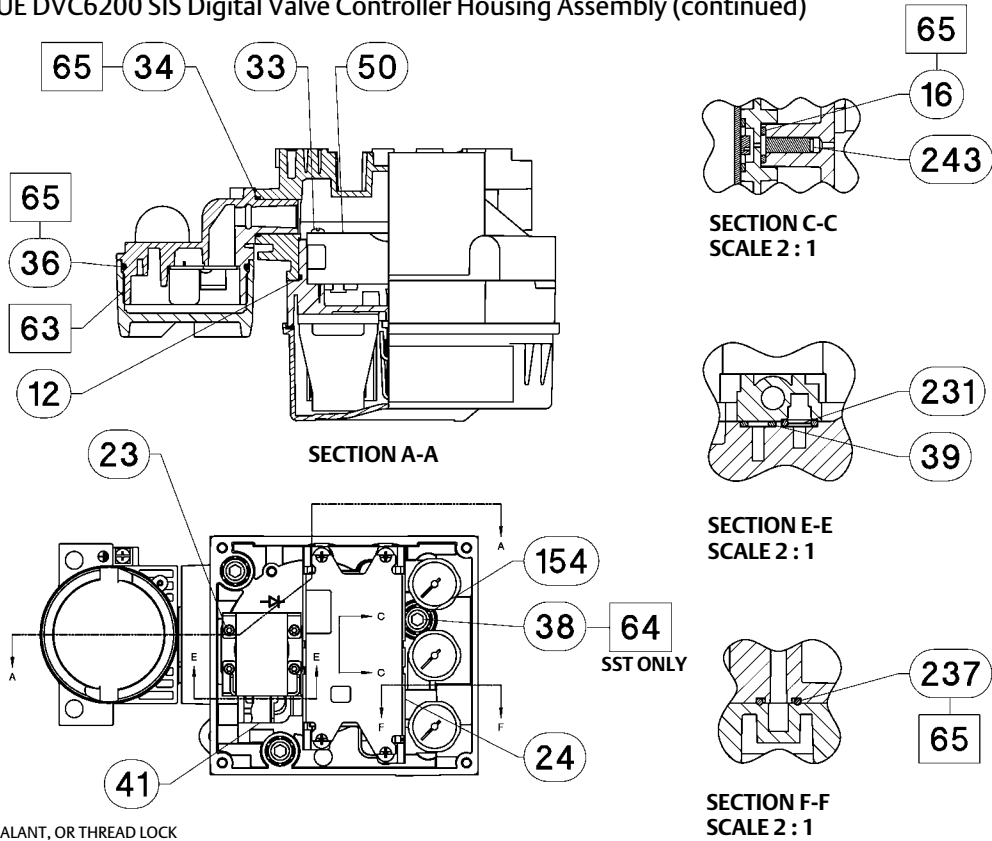

- APPLY LUBRICANT, SEALANT, OR THREAD LOCK
- 65 APPLY LUBRICANT ON ALL O-RINGS UNLESS OTHERWISE SPECIFIED

GE40185 sheet 2 of 3

Figure 7-3. Gauge Configuration

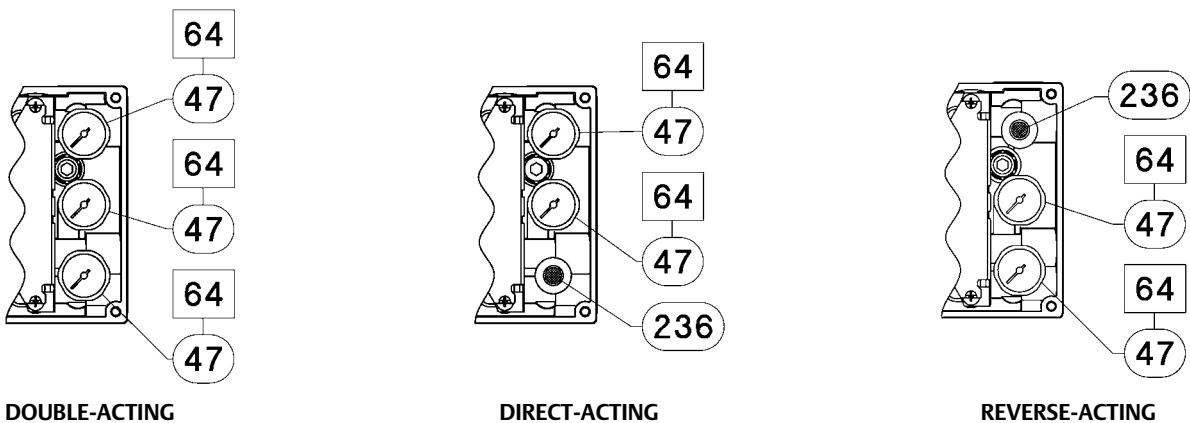

- FOR PIPE PLUG OPTION REPLACE 47 WITH 66
- FOR TIRE VALVE OPTION REPLACE 47 WITH 67

- APPLY LUBRICANT, SEALANT, OR THREAD LOCK
- 65 APPLY LUBRICANT ON ALL O-RINGS UNLESS OTHERWISE SPECIFIED

GE40185 sheet 3 of 3

Figure 7-4. FIELDVUE DVC6205 SIS Base Unit Housing Assembly

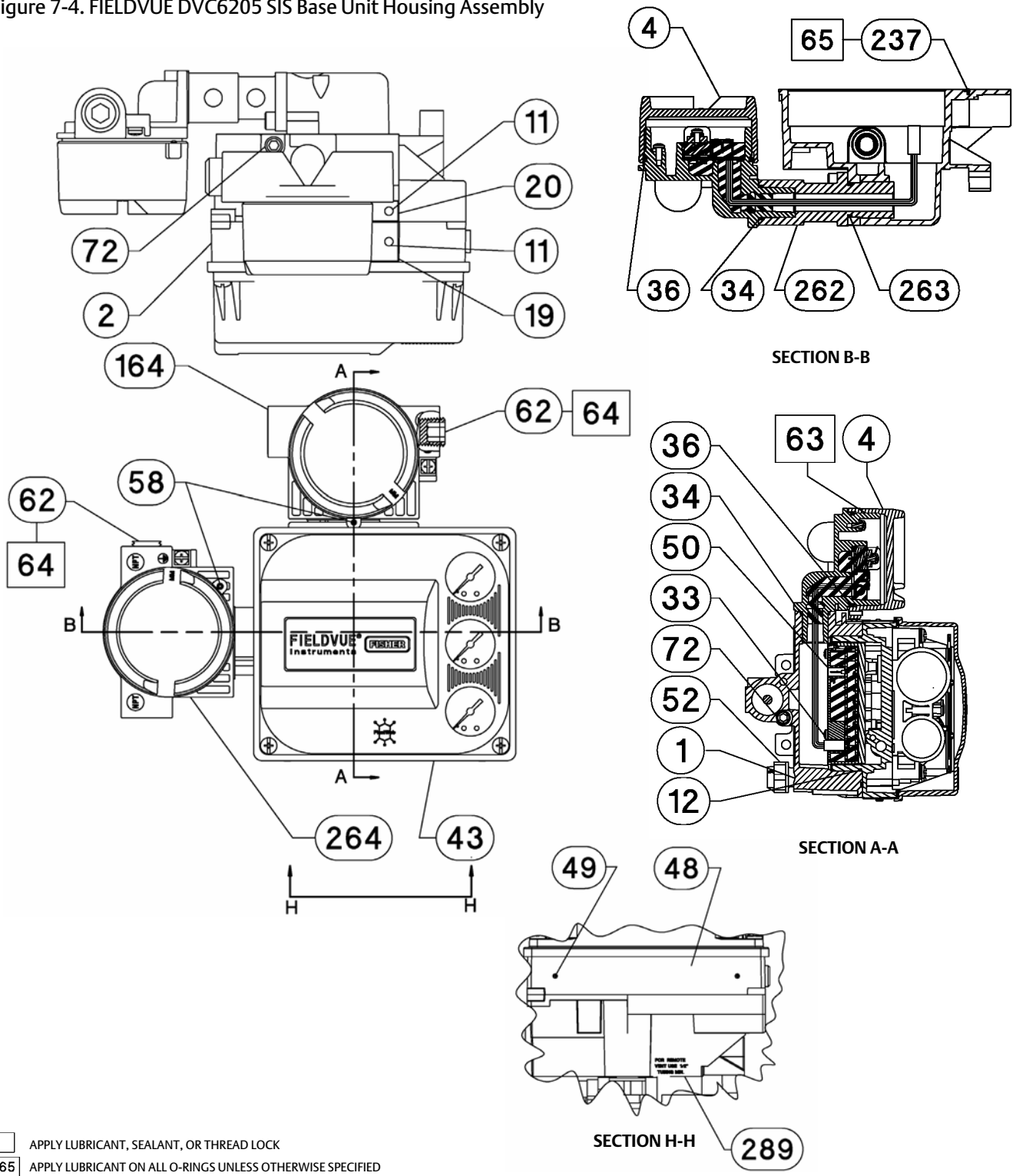

GE40181

Figure 7-4. FIELDVUE DVC6205 SIS Base Unit Housing Assembly (continued)

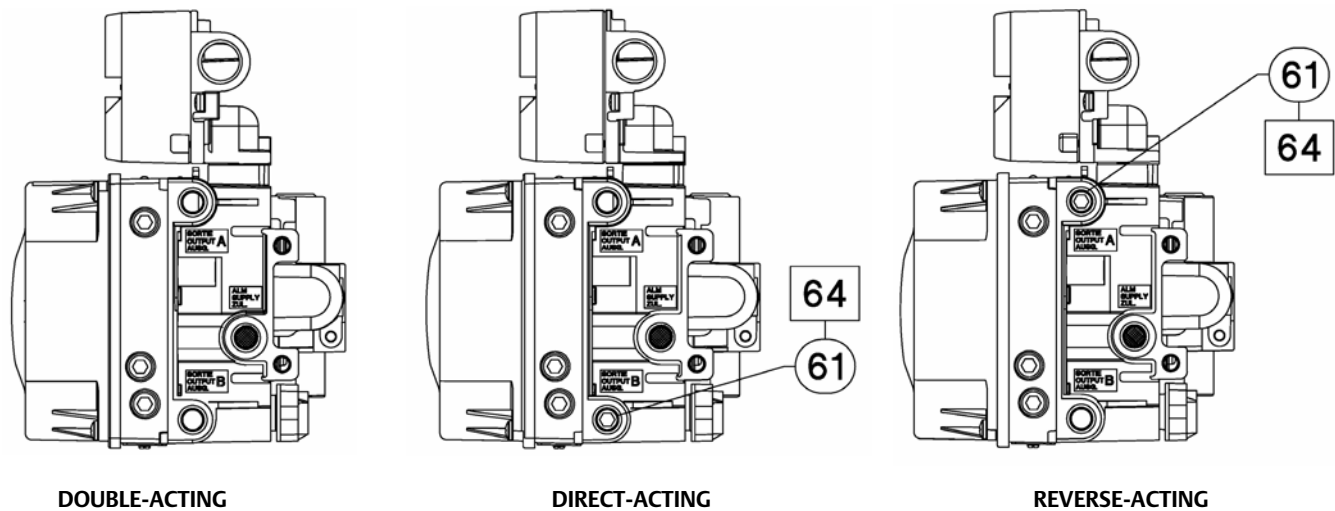
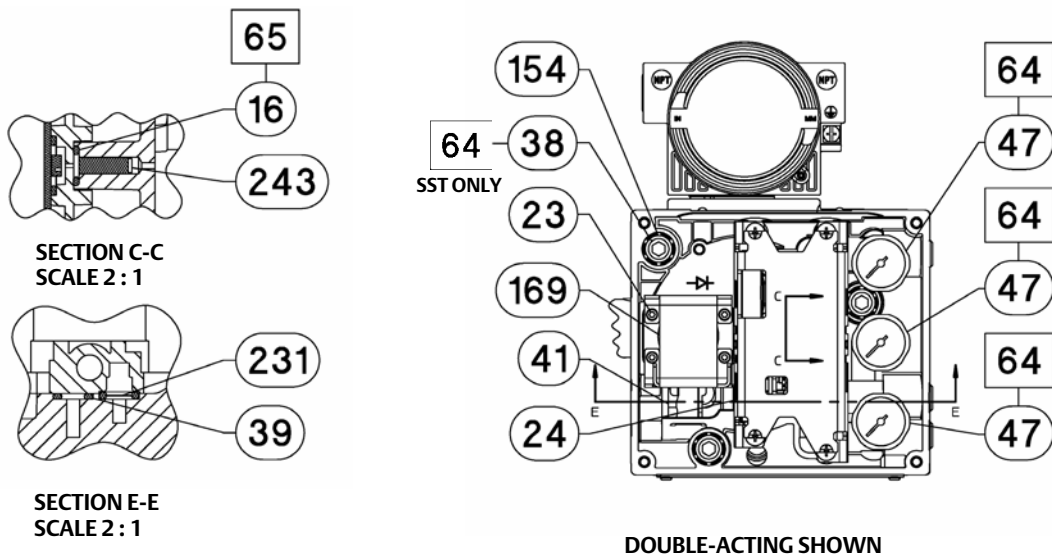

- APPLY LUBRICANT, SEALANT, OR THREAD LOCK
- 65 APPLY LUBRICANT ON ALL O-RINGS UNLESS OTHERWISE SPECIFIED

CE40181

Figure 7-4. FIELDVUE DVC6205 SIS Base Unit Housing Assembly (continued)

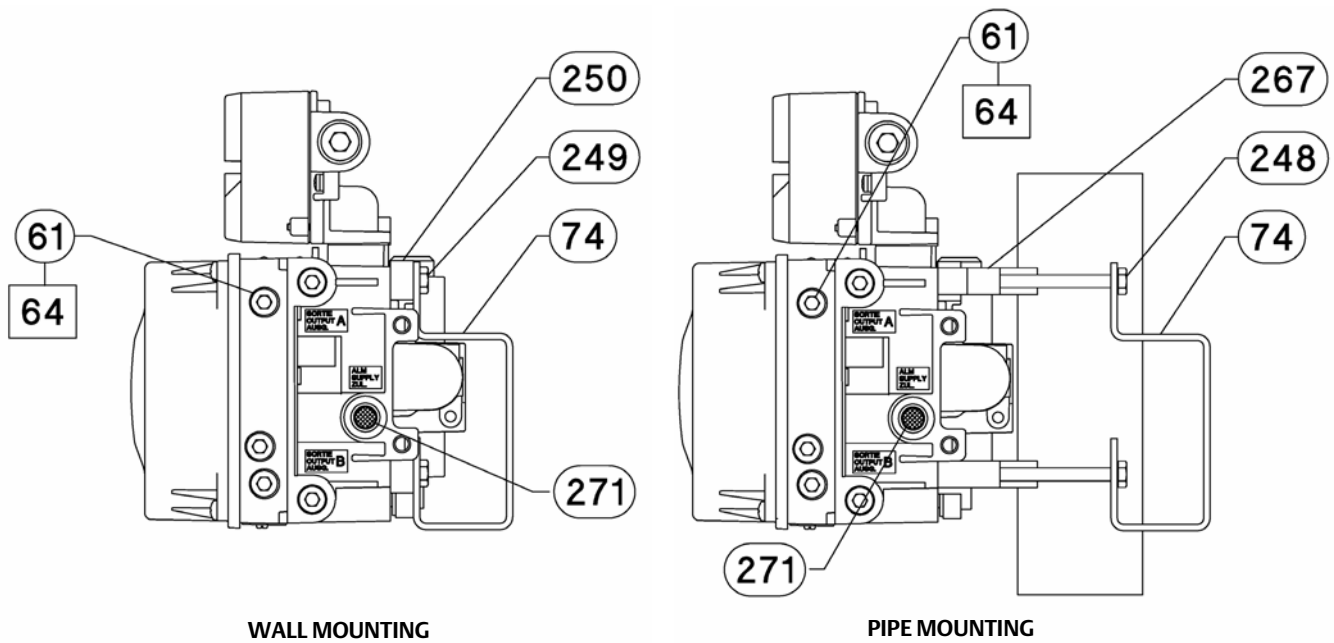

- APPLY LUBRICANT, SEALANT, OR THREAD LOCK
- 65 APPLY LUBRICANT ON ALL O-RINGS UNLESS OTHERWISE SPECIFIED

GE40181

Figure 7-5. FIELDVUE DVC6215 Remote Feedback Assembly

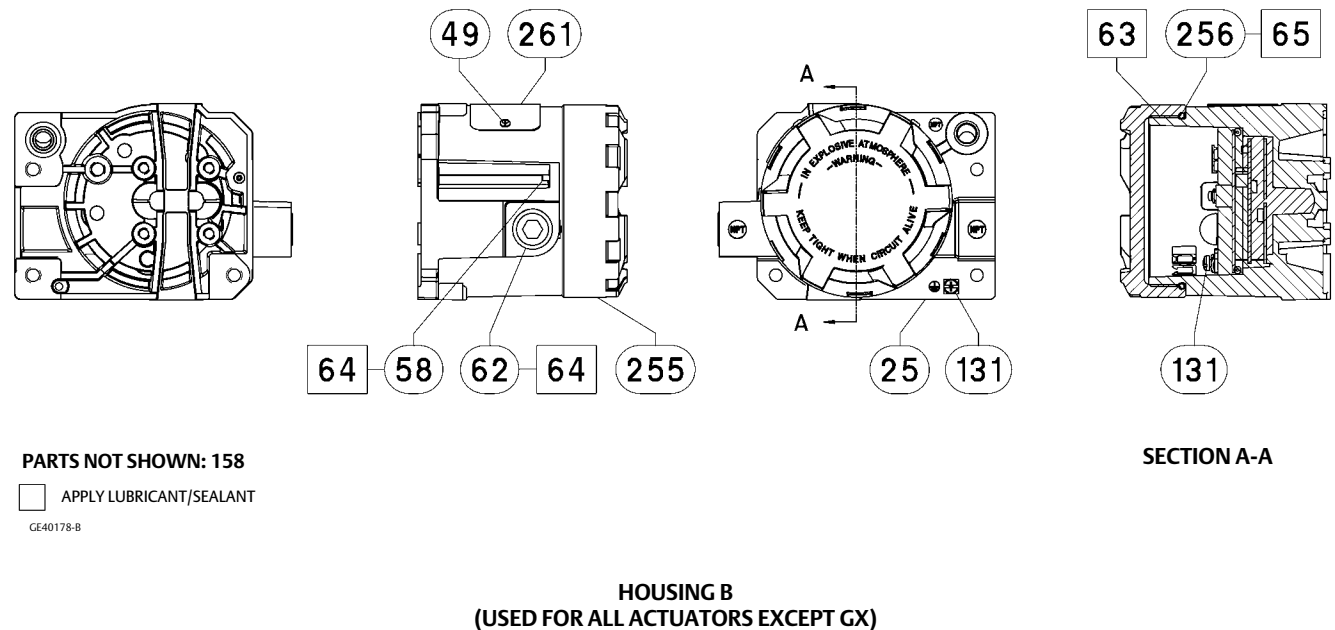
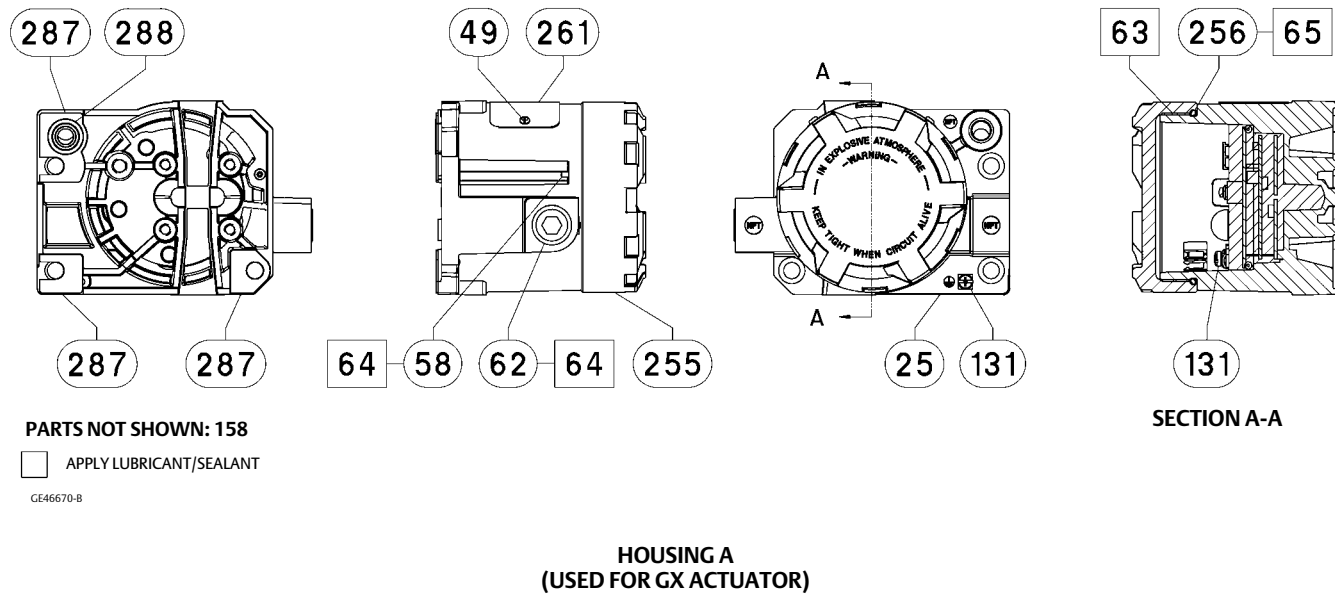

Appendix A Principle of Operation

HART Communication

The HART (Highway Addressable Remote Transducer) protocol gives field devices the capability of communicating instrument and process data digitally. This digital communication occurs over the same two-wire loop that provides the 4-20 mA process control signal, without disrupting the process signal. In this way, the analog process signal, with its faster update rate, can be used for control. At the same time, the HART protocol allows access to digital diagnostic, maintenance, and additional process data. The protocol provides total system integration via a host device.

The HART protocol uses frequency shift keying (FSK). Two individual frequencies of 1200 and 2200 Hz are superimposed over the 4-20 mA current signal. These frequencies represent the digits 1 and 0 (see figure A-1). By superimposing a frequency signal over the 4-20 mA current, digital communication is attained. The average value of the HART signal is zero, therefore no DC value is added to the 4-20 mA signal. Thus, true simultaneous communication is achieved without interrupting the process signal.

Figure A-1. HART Frequency Shift Keying Technique

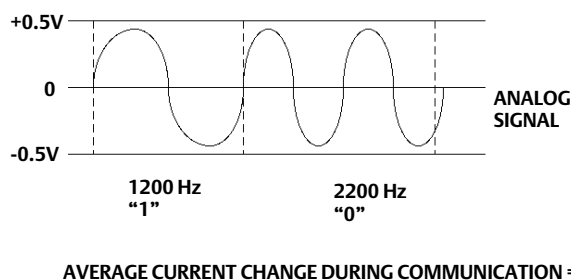

A6174

The HART protocol allows the capability of multidropping, i.e., networking several devices to a single communications line. This process is well suited for monitoring remote applications such as pipelines, custody transfer sites, and tank farms. See table 6-2 for instructions on changing the printed wiring board DIP switch configuration to multidrop.

DVC6200 SIS Digital Valve Controller

The DVC6200 SIS digital valve controller housing contains the travel sensor, terminal box, pneumatic input and output connections and a module base that may be easily replaced in the field without disconnecting field wiring or tubing. The module base contains the following submodules: I/P converter, printed wiring board (pwb) assembly, and pneumatic relay. The relay position is detected by sensing the magnet on the relay beam via a detector on the printed wiring board. This sensor is used for the minor loop feedback (MLFB) reading. The module base can be rebuilt by replacing the submodules. See figures A-3, A-4, A-5, and A-6.

Figure A-2. Typical FIELDVUE Instrument to Personal Computer Connections for ValveLink Software

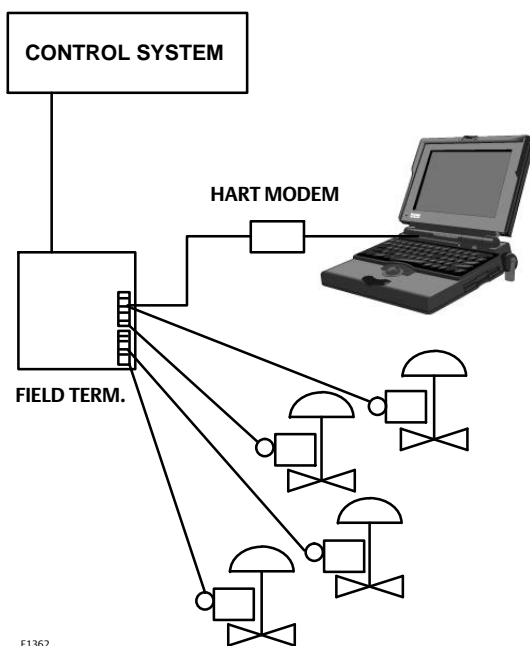

E1362

DVC6200 SIS digital valve controllers are loop-powered instruments that provide a control valve position proportional to an input signal from the control room. The following describes a double-acting digital valve controller mounted on a piston actuator.

The input signal is routed into the terminal box through a single twisted pair of wires and then to the printed wiring board assembly submodule where it is read by the microprocessor, processed by a digital algorithm, and converted into an analog I/P drive signal.

As the input signal increases, the drive signal to the I/P converter increases, increasing the I/P output pressure. The I/P output pressure is routed to the pneumatic relay submodule. The relay is also connected to supply pressure and amplifies the small pneumatic signal from the I/P converter. The relay accepts the amplified pneumatic signal and provides two output pressures. With increasing input (4 to 20 mA signal), the output A pressure always increases and the output B pressure decreases. The output A pressure is used for double-acting and single-acting direct applications. The output B pressure is used for double-acting and single-acting reverse applications. As shown in figure A-3, A-4, and A-5, the increased output A pressure causes the actuator stem to move downward. Stem position is sensed by the non-contact travel feedback sensor. The stem continues to move downward until the correct stem position is attained. At this point the printed wiring board assembly stabilizes the I/P drive signal. This positions the flapper to prevent any further increase in nozzle pressure.

As the input signal decreases, the drive signal to the I/P converter submodule decreases, decreasing the I/P output pressure. The pneumatic relay decreases the output A pressure and increases the output B pressure. The stem moves upward until the correct position is attained. At this point the printed wiring board assembly stabilizes the I/P drive signal. This positions the flapper to prevent any further decrease in nozzle pressure.

Figure A-3. FIELDVUE DVC6200 SIS Digital Valve Controller Block Diagram

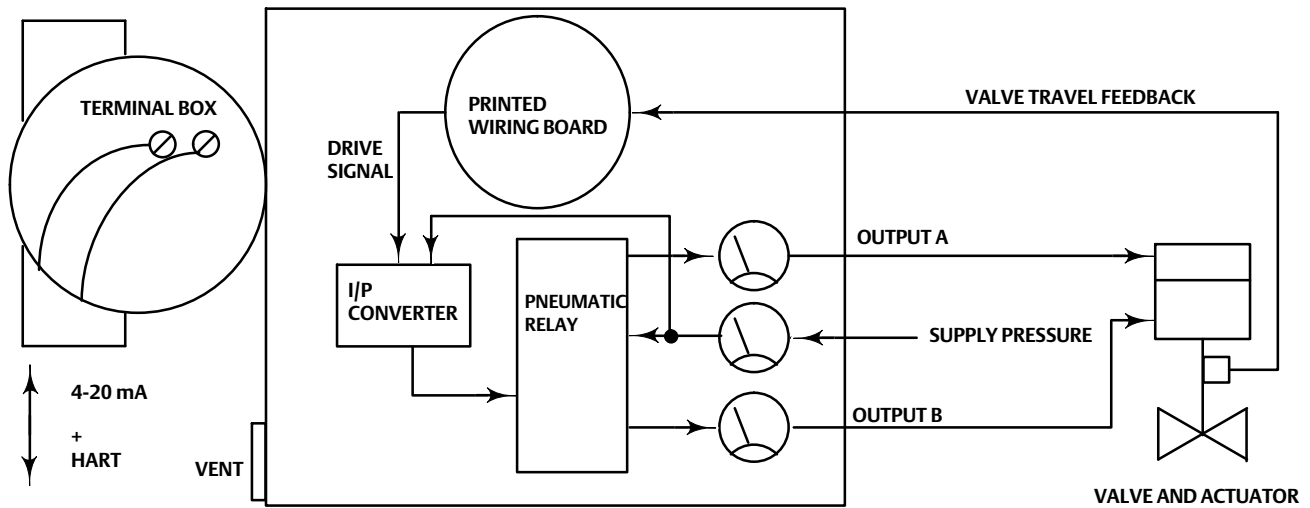

INPUT SIGNAL

E1470

Figure A-4. FIELDVUE DVC6200 SIS Digital Valve Controller with Position Transmitter Block Diagram

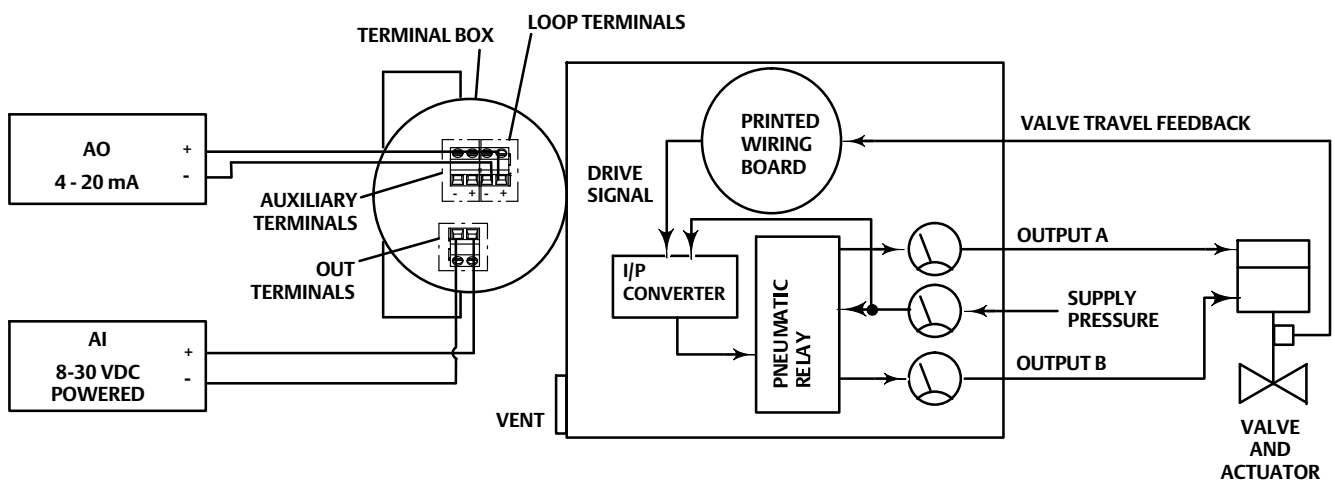

Figure A-5. FIELDVUE DVC6200 SIS Digital Valve Controller with Discrete Switch Block Diagram

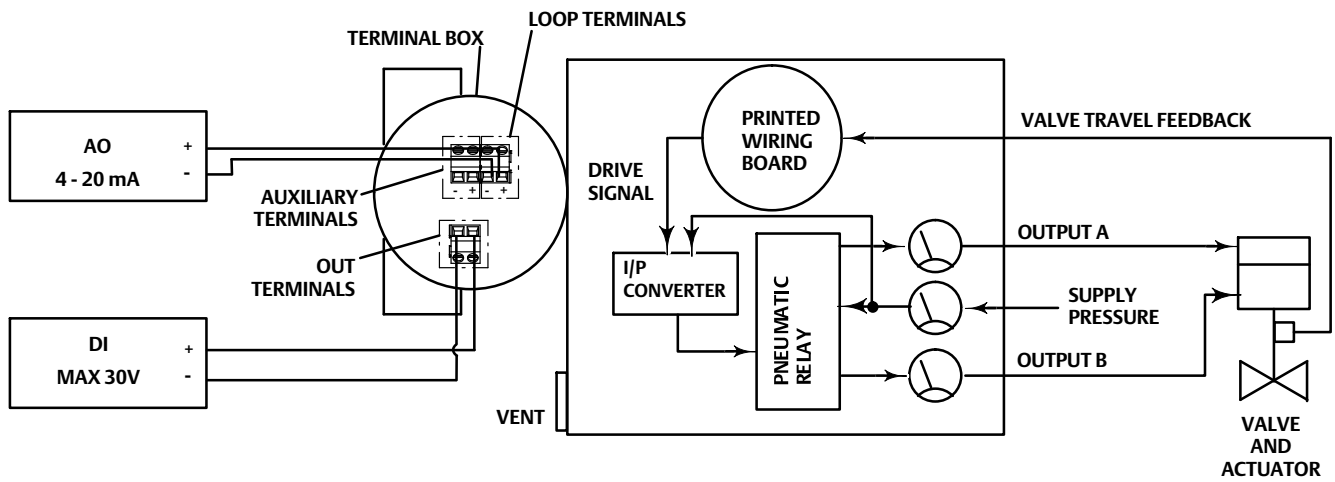
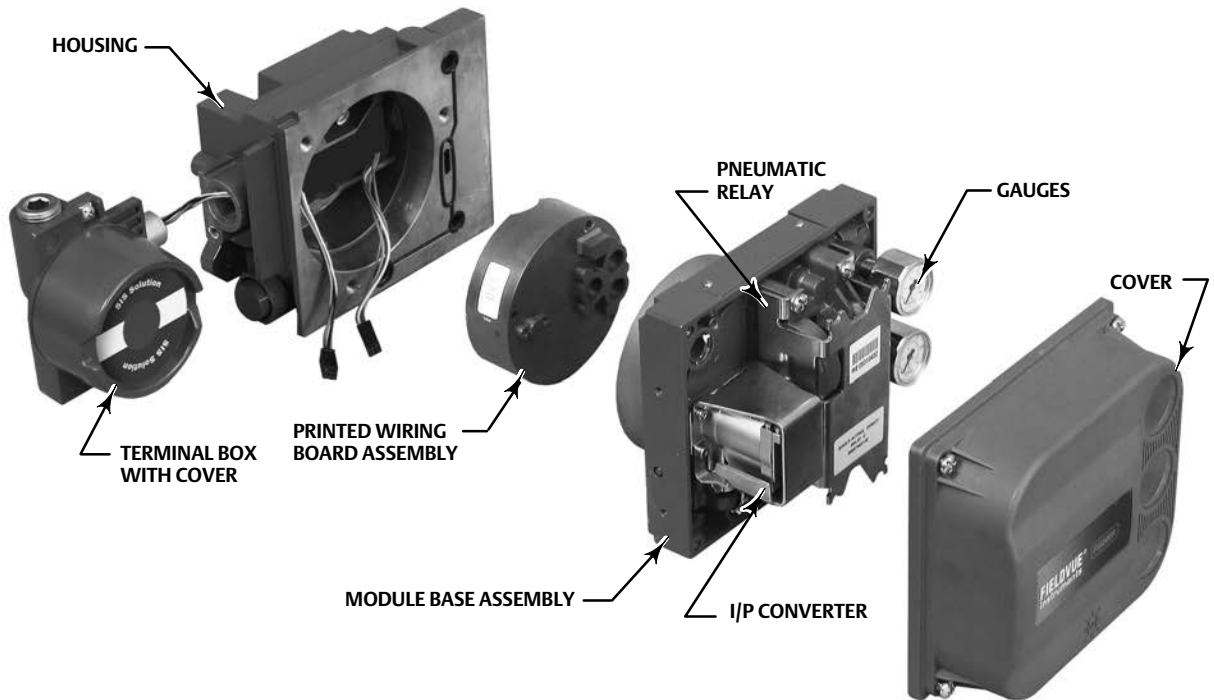

Figure A-6. FIELDVUE DVC6200 SIS Digital Valve Controller Assembly



W9925-2-SIS

Appendix B Device Communicator Menu Trees

This section contains the Device Communicator menu trees. It also contains an alphabetized function/variable list to help locate the function/variable on the appropriate menu tree. All Fast Key Sequences referenced in the menu trees assume the Online menu (see figure B-2) as the starting point.

Note

Fast-key sequences are only applicable to the 475 Field Communicator. They do not apply to the Trex Device Communicator.

Function/Variable	See Figure
Action on Failed Test	B-7
Actual Travel	B-5
Actuator Manufacturer	B-5
Actuator Model	B-5
Actuator Selection	B-5
Actuator Size	B-5
Actuator Style	B-7
Air	B-5
Alert Mapping to F...	B-7
Alert Record Full (Alert Record/Status Alerts Enable)	B-9
Alert Record Full (Alert Record/Status Alerts NE107)	B-9
Alert Record Not Empty (Alert Record/Status Alerts Enable)	B-9
Alert Record Not Empty (Alert Record/Status Alerts NE107)	B-9
Alert Switch Source	B-7
Analog Input	B-3, B-11
Analog Input (Calibration)	B-10
Analog Input Units	B-5
Area Units	B-5
Auto Calibration	B-4, B-10
Autocal in Progress (Alert Record/Status Alerts Enable)	B-9
Autocal in Progress (Alert Record/Status Alerts NE107)	B-9
Auto Partial Stroke Test Interval	B-7
Auxiliary Terminal Action	B-5
Breakout Timeout	B-7
Breakout Torque	B-5
Burst Command	B-7
Burst Enable	B-7
Calibration Button	B-5
Calibration in Progress (Alert Record/Status Alerts Enable)	B-9
Calibration in Progress (Alert Record/Status Alerts NE107)	B-9
Calibration Record	B-10
Calibration Time	B-10
Calibration Type	B-10
Calibrator	B-10
Change EPPC Enable	B-6
Change Instrument Mode	B-1, B-5
Change Reset Mode	B-7

Function/Variable	See Figure
Change to HART 5 / Change to HART 7	B-11
Change Write Protection	B-1, B-3, B-5
Clear Records	B-9, B-11
Critical NVM Failure (PST Prohibited Electronics Alerts)	B-9
Critical NVM Failure (Electronics Alerts NE107)	B-8
Critical NVM Failure Shutdown	B-8
Custom Characterization	B-6, B-11
Cycle Count	B-8, B-11
Cycle Count Hi (Travel History Alerts Enable)	B-8
Cycle Count High (Travel History Alerts NE107)	B-8
Cycle Count High Alert Point	B-8
Cycle Count/Travel Accum Deadband	B-8
Days Powered Up	B-11
DD Information	B-3
Demand Breakout Time	B-8
Demand Breakout Time Alert Point	B-8
Demand Stroke Time	B-7, B-8
Demand Stroke Time Alert Point	B-8
Description	B-3, B-5
Device ID	B-3
Device Revision	B-3
Device Setup	B-4
Device Status	B-3, B-11
Diagnostic Data Available (Alert Record/Status Alerts Enable)	B-9
Diagnostic Data Available (Alert Record/Status Alerts NE107)	B-9
Diagnostic in Progress (Alert Record/Status Alerts Enable)	B-9
Diagnostic in Progress (Alert Record/Status Alerts NE107)	B-9
Drive Current Failure (Electronics Alerts NE107)	B-8
Drive Current Failure (PST Prohibited Electronics Alerts)	B-9
Drive Current Failure Shutdown	B-8
Drive Signal	B-3, B-11
Drive Signal (Electronics Alerts Enable)	B-8
Drive Signal (Electronics Alerts NE107)	B-8
Dynamic Torque	B-5
Edit Auxiliary Terminal Action	B-5
Edit Cycle Counts	B-8
Edit Instrument Time	B-5, B-9
Edit Travel Accumulator	B-8
Effective Area	B-5

Function/Variable	See Figure
EPPC Enable	B-6
EPPC Saturation Time	B-6
EPPC Set Point	B-6
Fail Signal	B-7
Feedback Connection	B-5, B-7
Firmware Revision	B-3
Flash Integrity Failure (Electronics Alerts NE107)	B-8
Flash Integrity Failure (PST Prohibited Electronics Alerts)	B-9
Flash Integrity Failure Shutdown	B-8
Flow Direction	B-5
Flow Tends to	B-5
Function	B-7
Hardware Revision (Device)	B-3
HART Long Tag	B-3, B-5
HART Tag	B-3, B-5
HART Universal Revision	B-3
HART Variable Assignments	B-7
High Friction Breakout Pressure	B-7
Hi Cutoff Point	B-6, B-8
Hi Cutoff Select	B-6
Hi Soft Cutoff Rate	B-6
Incoming Pressure Threshold	B-7
Independent SOV Test	B-7
Inlet Pressure	B-5
Input Characterization	B-6, B-11
Instrument Alert Record	B-9
Instrument Level	B-3
Instrument Mode	B-1, B-5
Instrument Serial Number	B-3, B-5
Instrument Time is Approximate (Alert Record/Status Alerts Enable)	B-9
Instrument Time is Approximate (Alert Record/Status Alerts NE107)	B-9
Integral Enable (Travel & EPPC Tuning)	B-6
Integral Gain (Travel & EPPC Tuning)	B-6
Integrator Limit	B-6
Integrator Saturated Hi (Alert Record/Status Alerts Enable)	B-9
Integrator Saturated Hi (Alert Record/Status Alerts NE107)	B-9
Integrator Saturated Lo (Alert Record/Status Alerts Enable)	B-9
Integrator Saturated Lo (Alert Record/Status Alerts NE107)	B-9
Integral Dead Zone	B-6
Last AutoCal Status	B-10
Last PST Results	B-7
Latch on Position Trip	B-7
LCP Button Stuck (LCP Control Panel Alerts Enable)	B-9
LCP Button Stuck (LCP Control Panel Alerts NE107)	B-9
LCP Communication Failure (LCP Control Panel Alerts Enable)	B-9
LCP Communication Failure (LCP Control Panel Alerts NE107)	B-9
LCP LED Test	B-11
LCP Model	B-7

Function/Variable	See Figure
LCP Tripped Alert Latch	B-7
Leak Class	B-5
Length Units	B-5
Lever Arm Length	B-5
Lever Style	B-5
Limit Switch Trip Point	B-7
Limit Switch Valve Close	B-5
Limit Switch Valve Open	B-5
Lo Cutoff Point	B-6, B-8
Lo Cutoff Select	B-6
Loop Current Validation	B-8
Loop Current Validation Shutdown	B-8
Lo Soft Cutoff Rate	B-6
Low Friction Breakout Pressure	B-7
Lower Bench Set	B-5
Manual Calibration	B-10
Manual Reset Required (Partial Stroke Alerts Enable)	B-9
Manual Reset Required (Partial Stroke Alerts NE107)	B-9
Manufacturer (Device)	B-3
Maximum Allowable Pressure Drop Alert Point	B-9
Maximum Allowable Travel Movement	B-7
Maximum Recorded Temperature	B-11
Maximum Supply Pressure	B-7
Message	B-3, B-5
Minimum Required Pressure Drop Alert Point	B-9
Minimum Required Travel Movement	B-7
Minimum Recorded Temperature	B-11
Minor Loop Sensor Failure (PST Prohibited Electronic Alerts)	B-9
Minor Loop Sensor Failure (Sensor Alert NE107)	B-9
Minor Loop Sensor Failure Shutdown	B-9
MLFB Gain (Travel & EPPC Tuning)	B-6
Model (Device)	B-3
Monitoring Time	B-7
Nominal Supply	B-5
Non-Critical NVM Failure (Electronics Alerts NE107)	B-8
Non-Critical NVM Failure Shutdown	B-8
Number of Power Ups	B-11
On Abnormal SOV Test	B-7
Outgoing Pressure Threshold	B-7
Outlet Pressure	B-5
Output Circuit Error (Electronics Alerts Enable)	B-8
Output Circuit Error (Electronics Alerts NE107)	B-8
Output Pressure Limit Enable	B-8
Output Terminal Enable	B-7
Packing Type	B-5
Partial Stroke Test	B-11
Polling Address	B-5
Port A Overpressurized (Pressure Alerts Enable)	B-8
Port A Overpressurized (Pressure Alerts NE107)	B-8
Port A Pressure Limit	B-8
Port Diameter	B-5
Port Type	B-5
Position Transmitter	B-5
Position Trip Point	B-7

Function/Variable	See Figure
Pressure A	B-3, B-11
Pressure A-B	B-3, B-11
Pressure B	B-3, B-11
Pressure Control	B-9
Pressure Deviation Alert Point	B-8
Pressure Deviation (Pressure Alerts Enable)	B-8
Pressure Deviation (Pressure Alerts NE107)	B-8
Pressure Deviation Time	B-8
Pressure Fallback Active (PST Prohibited Alerts Enable)	B-9
Pressure Sensor Failure (PST Prohibited Alerts Enable)	B-9
Pressure Sensor Failure (Sensor Alerts NE107)	B-9
Pressure Sensor Failure Shutdown	B-9
Pressure Sensors (Calibration)	B-10
Pressure Tuning Set	B-6
Pressure Units	B-5
Program Flow Failure (Partial Stroke Alerts NE107)	B-9
Program Flow Failure Shutdown	B-9
Proportional Gain (Travel & EPPC Tuning)	B-6
PST Abnormal (Partial Stroke Alerts Enable)	B-9
PST Abnormal (Partial Stroke Alerts NE107)	B-9
PST Abnormal Criteria	B-7
PST Abort Criteria	B-7
PST Enable	B-7
PST Calibration	B-10
PST Deferral Reason	B-7
PST Pass (Partial Stroke Alerts Enable)	B-9
PST Pass (Partial Stroke Alerts NE107)	B-9
PST Prohibited (Partial Stroke Alerts Enable)	B-9
PST Prohibited (Partial Stroke Alerts NE107)	B-9
PST Result Criticality	B-7
PST Start Point	B-7
PST Variables	B-7
Pulse Duration	B-7
Push Down To	B-5
PWB Serial Number	B-3
Rated Travel	B-5
Relay Adjust	B-10
Relay Type	B-7
Reference Voltage Failure (Electronics Alerts NE107)	B-8
Reference Voltage Failure (PST Prohibited Electronics Alerts)	B-9
Reference Voltage Failure Shutdown	B-8
Reset Latch	B-11
Reset LCP Communication	B-11
Reset Pressure (SOV Test Alerts Enable)	B-9
Reset PST Abnormal Alert	B-11
Reset Stroke Time	B-8
Reset Stroke Time Alert Point	B-8
Restart Processor	B-11
Return Lead	B-7
Seat Type (Trim)	B-5
Setpoint	B-3, B-8, B-11
Short Duration PST	B-7
Shutdown Activated (Electronics Alerts Enable)	B-8

Function/Variable	See Figure
Shutdown Activated (Electronics Alerts NE107)	B-8
Simulate	B-11
SIS Hardware Failure (Partial Stroke Alerts NE107)	B-9
SIS Hardware Failure Shutdown	B-9
SIS Stroke Alerts Enable	B-8
SIS Stroke Time (Travel History Alerts Enable)	B-8
SIS Stroke Time (Travel History Alerts NE107)	B-8
Solenoid Valve	B-5
SOV Test Before PST	B-7
SOV Test Calibration	B-10
SP Rate Close	B-6
SP Rate Open	B-6
Spring Rate	B-5
Spring Rate Units	B-5
Stabilize/Optimize	B-7, B-11
Start PST on Loop Current Trigger	B-7
Stem Diameter	B-5
Stroke Valve	B-11
Supply Pressure	B-3, B-8, B-11
Supply Pressure Hi (Pressure Alerts Enable)	B-8
Supply Pressure Hi (Pressure Alerts NE107)	B-8
Supply Pressure Hi Alert Point	B-8
Supply Pressure Lo (PST Prohibited Alerts Enable)	B-8
Supply Pressure Lo (Pressure Alerts Enable)	B-8
Supply Pressure Lo Alert Point	B-6, B-8
Switch Closed	B-7
Temperature	B-11
Temperature Units	B-5
Temp Sensor Failure (PST Prohibited Alerts Enable)	B-9
Temp Sensor Failure (Sensor Alerts NE107)	B-9
Temp Sensor Failure Shutdown	B-9
Torque Units	B-5
Transmitter Output	B-7
Travel	B-3, B-8, B-11
Travel Accumulator (Alert Setup)	B-8
Travel Accumulator (Travel History)	B-11
Travel Accumulator Alert Point	B-8
Travel Accumulator High (Travel History Alerts Enable)	B-8
Travel Accumulator High (Travel History Alerts NE107)	B-8
Travel Alert Deadband	B-8
Travel Counts	B-11
Travel Deviation	B-8
Travel Deviation (PST Prohibited Alerts Enable)	B-9
Travel Deviation (Travel Alerts Enable)	B-8
Travel Deviation (Travel Alerts NE107)	B-8
Travel Deviation Alert Point	B-8
Travel Deviation Time	B-8
Travel Hi (Travel Alerts Enable)	B-8
Travel Hi (Travel Alerts NE107)	B-8
Travel Hi Hi (Travel Alerts Enable)	B-8
Travel Hi Hi (Travel Alerts NE107)	B-8
Travel Hi Alert Point	B-8

Function/Variable	See Figure
Travel Hi Hi Alert Point	B-8
Travel Lo (Travel Alerts Enable)	B-8
Travel Lo (Travel Alerts NE107)	B-8
Travel Lo Lo (Travel Alerts Enable)	B-8
Travel Lo Lo (Travel Alerts NE107)	B-8
Travel Lo Alert Point	B-8
Travel Lo Lo Alert Point	B-8
Travel Cutoff Hi (Travel Alerts Enable)	B-8
Travel Cutoff Hi (Travel Alerts NE107)	B-8
Travel Cutoff Lo (Travel Alerts Enable)	B-8
Travel Cutoff Lo (Travel Alerts NE107)	B-8
Travel Sensor Failure (Sensor Alerts NE107)	B-9
Travel Sensor Failure (PST Prohibited Alerts Enable)	B-9
Travel Sensor Failure Shutdown	B-9
Travel Sensor Motion	B-5, B-7
Travel Tuning Set	B-7
Travel Units	B-5
Tripped by LCP (Partial Stroke Alerts Enable)	B-9

Function/Variable	See Figure
Tripped by LCP (Partial Stroke Alerts NE107)	B-9
Tripped by LCP Latch Alert	B-9
Trip Pressure (SOV Test Alerts Enable)	B-9
Unbalanced Area	B-5
Upper Bench Set	B-5
Valve Class	B-5
Valve Manufacturer	B-5
Valve Model	B-5
Valve Serial Number	B-3, B-5
Valve Size	B-5
Valve Style	B-5, B-7
Velocity Gain	B-7
View Alert Records	B-9, B-11
View/Edit Burst Messages	B-7
View/Edit Lag Time	B-6
Volume Booster	B-5
Write Protection	B-1, B-3, B-5
Zero Power Condition	B-7

Figure B-1. Hot Key

Favorites
Hot Key

- 1 Instrument Mode
- 2 Change Instrument Mode
- 3 Write Protection
- 4 Change Write Protection

Figure B-2. Online

HART Application

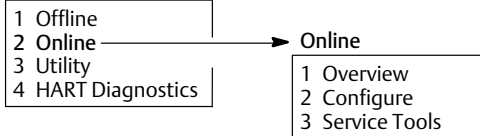

Figure B-3. Overview

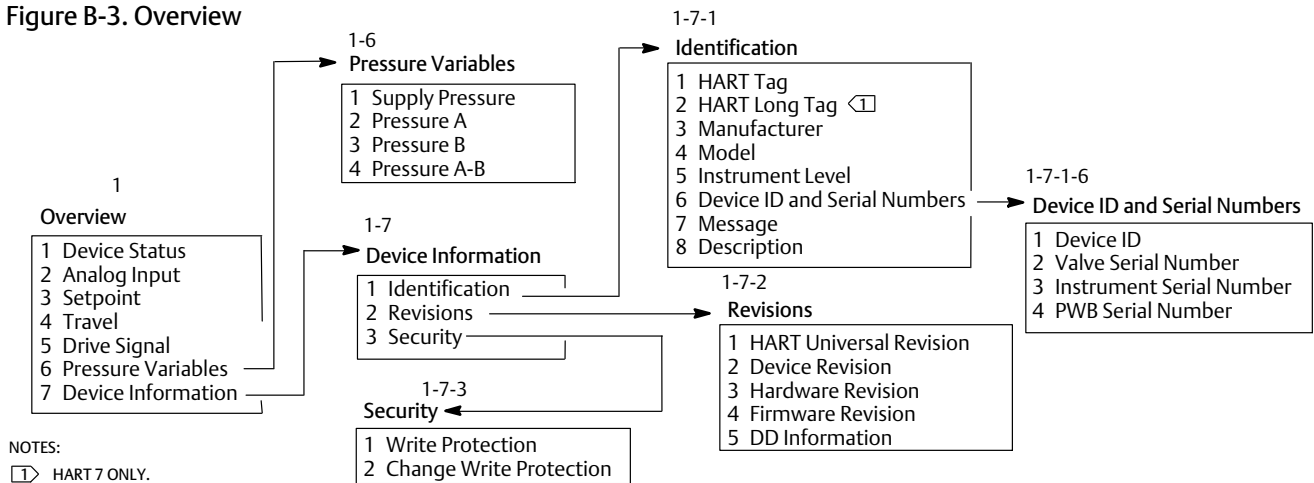

Figure B-4. Guided Setup

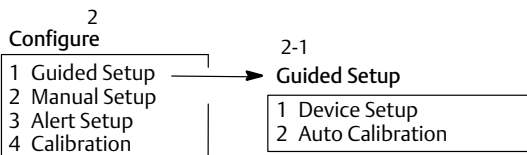
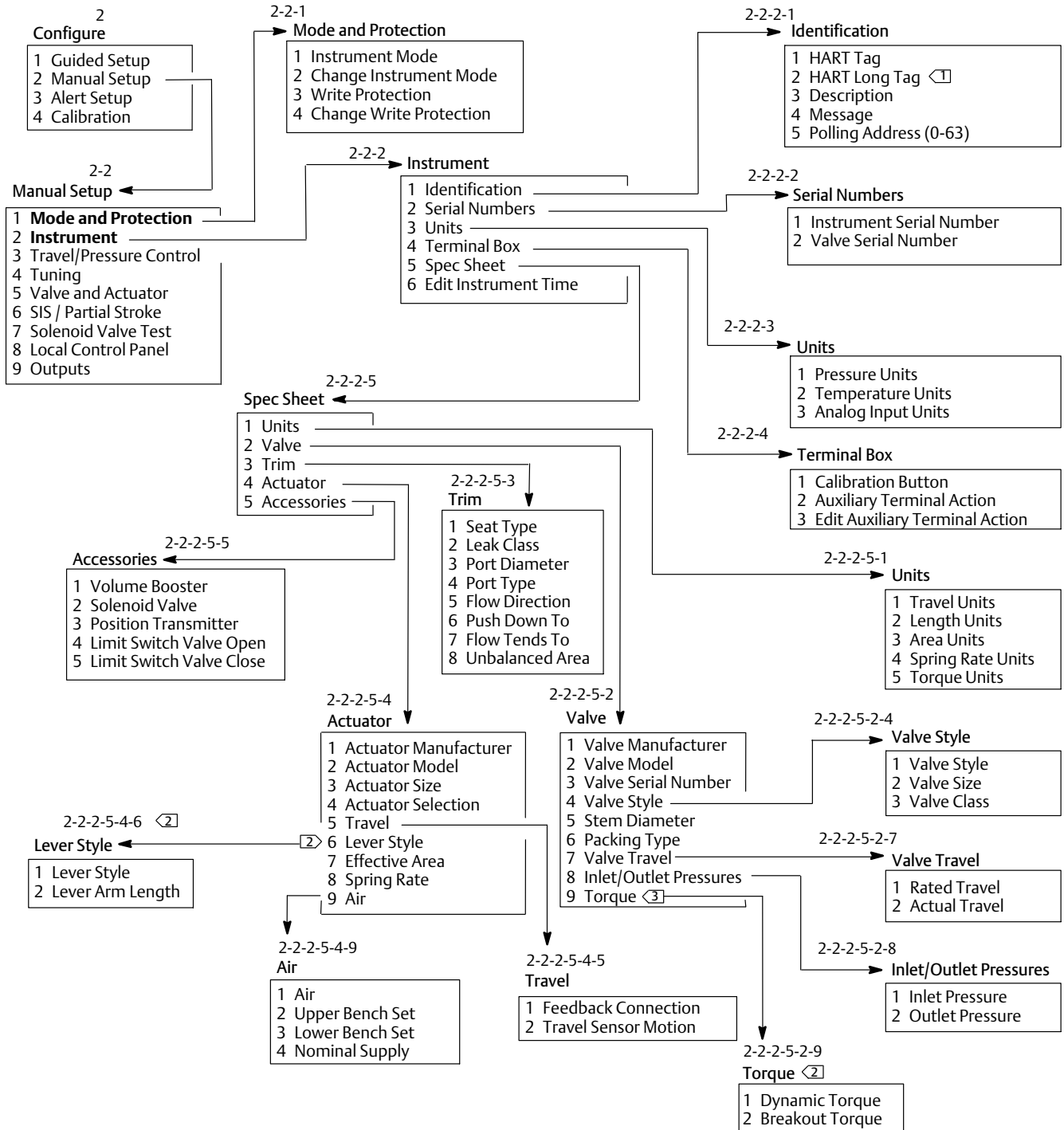

Figure B-5. Manual Setup > Mode Protection & Manual Setup > Instrument



NOTES:

- ① HART 7 ONLY.
- ② AVAILABLE WHEN VALVE IS ROTARY.

Figure B-6. Manual Setup > Travel/Pressure Control & Manual Setup > Tuning

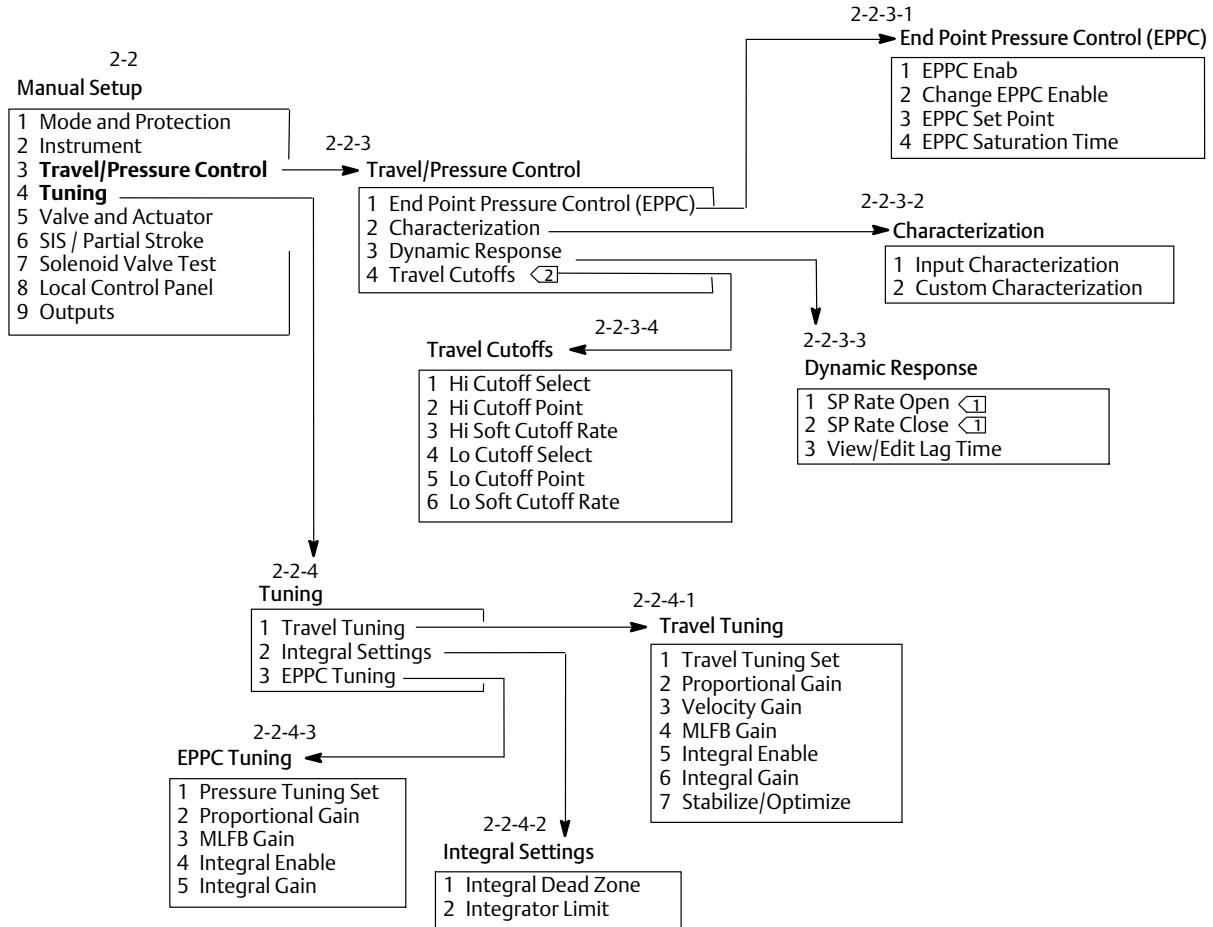

NOTE:

- ① SP RATE OPEN AND SP RATE CLOSE ARE NOT VISIBLE WHEN SHUTDOWN SWITCHES ARE ENABLED.
- ② THE TRAVEL CUTOFFS MENU IS NOT VISIBLE WHEN SHUTDOWN SWITCHES ARE ENABLED.

Figure B-7. Manual Setup > Valve and Actuator through Manual Setup > Outputs

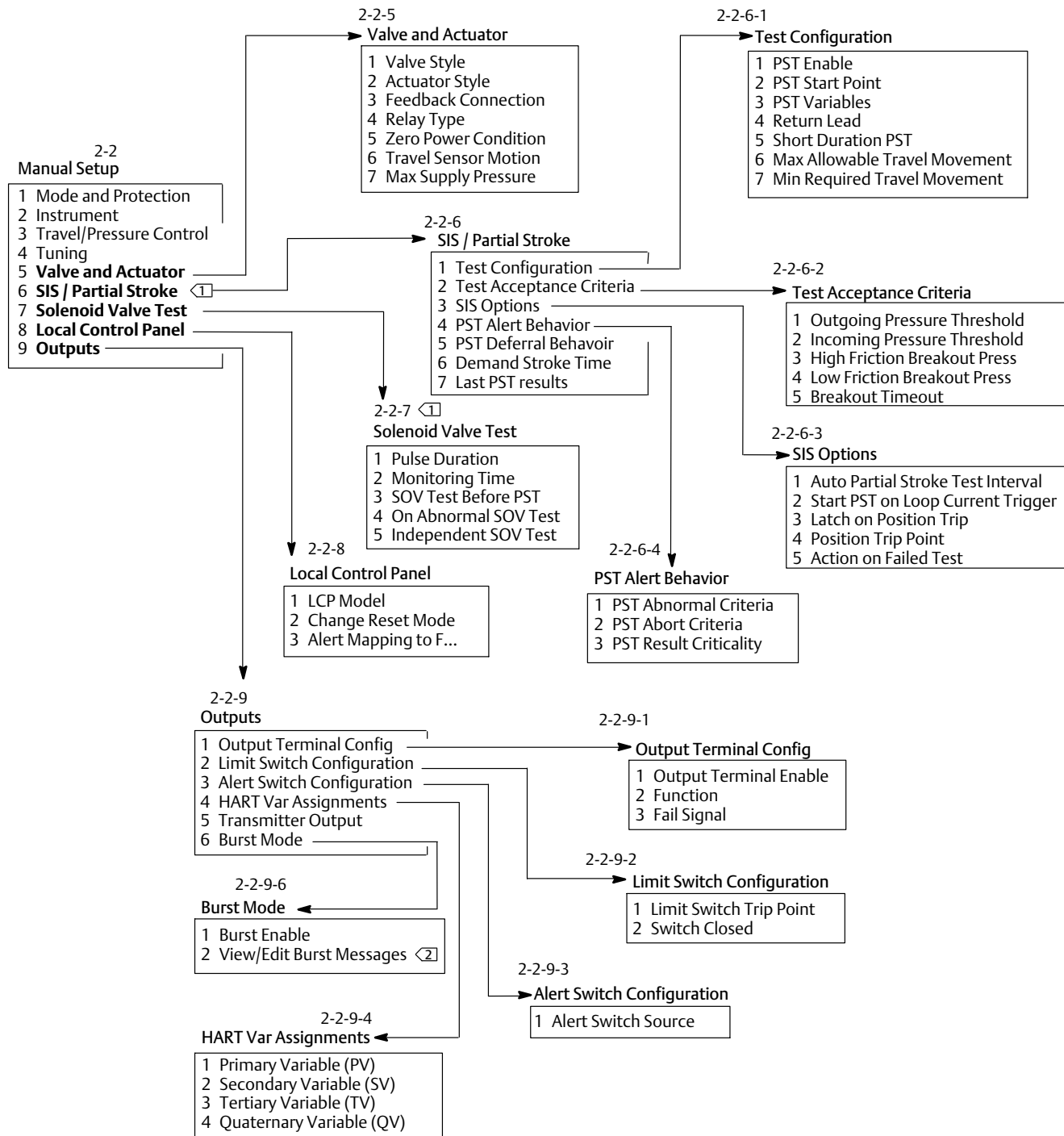

NOTES:

☐ HART 7 ONLY.

☐ LABEL IS 'BURST COMMAND' FOR HART 5.

Figure B-8. Alert Setup > Electronics through Travel History

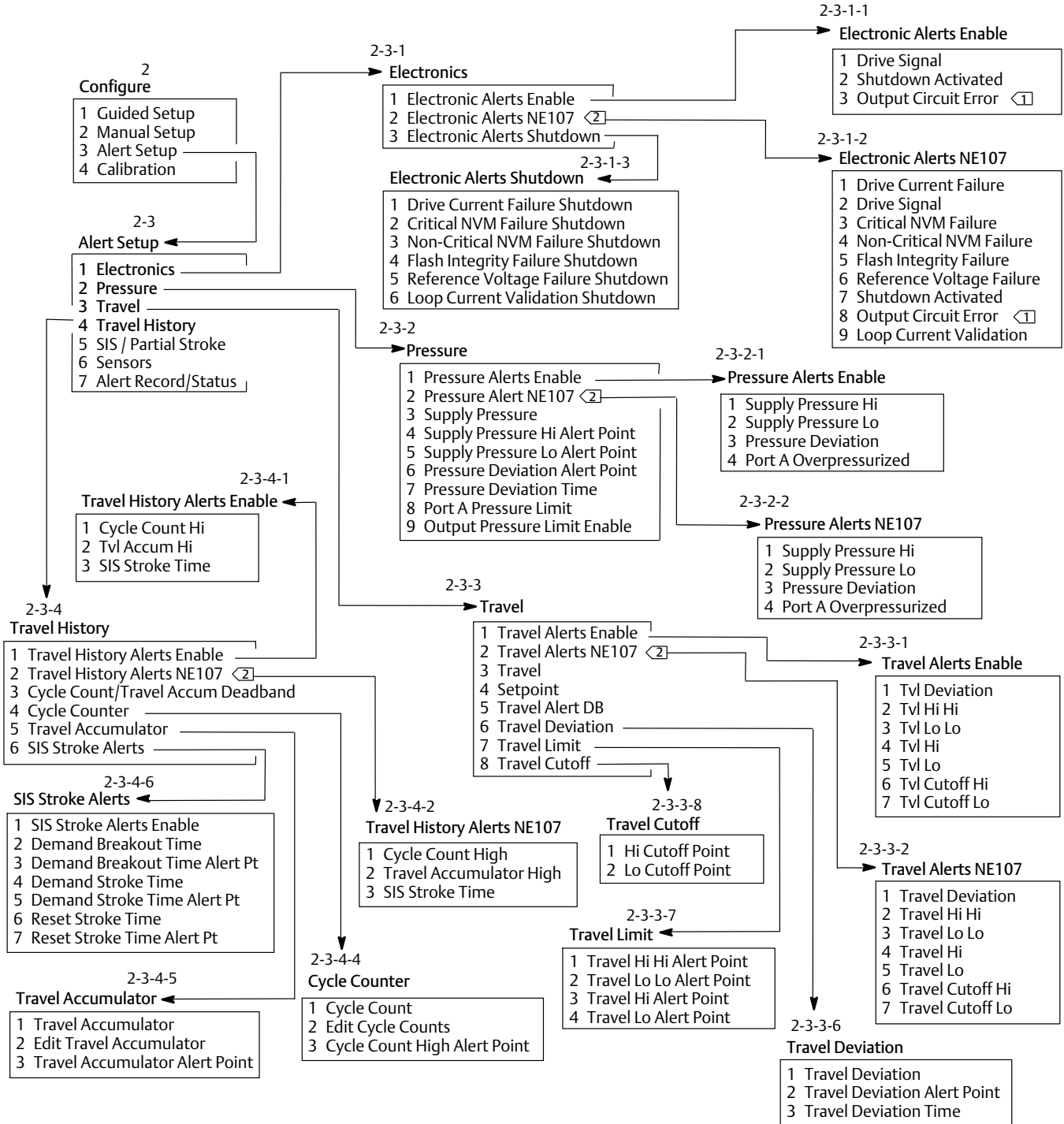

NOTES:

1 OUTPUT CIRCUIT ERROR IS AVAILABLE WHEN THE TRANSMITTER FUNCTION IS CONFIGURED.

2 NE107 ALERTS ARE AVAILABLE FOR HART 7. ALL HART 5 FAST-KEY SEQUENCES WILL DECREASE BY ONE NUMBER AFTER THE NE107 ALERT CONFIGURATION ENTRY.

Figure B-9. Alert Setup > SIS / Partial Stroke through Alert Record/Status

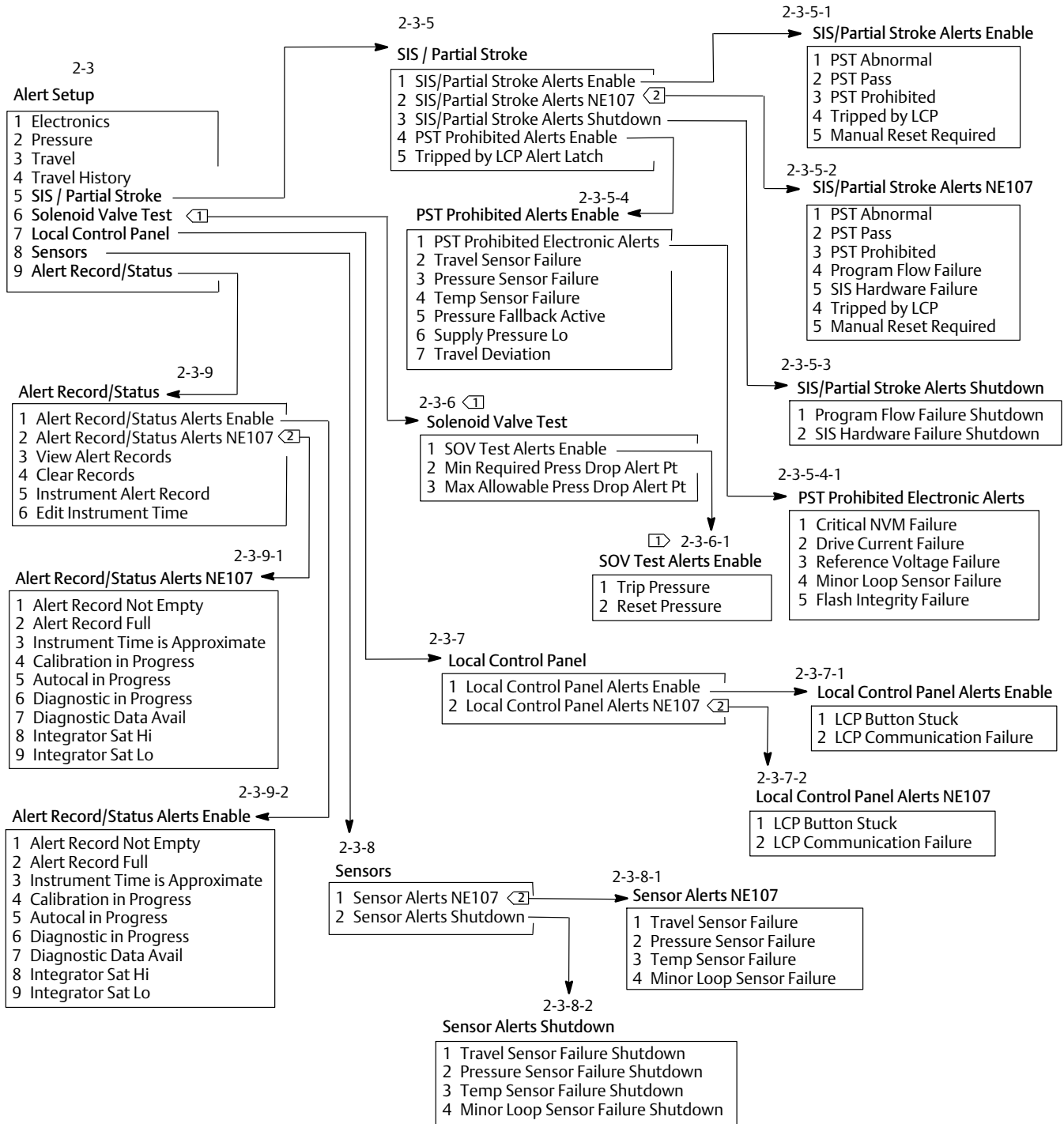

NOTES:

① HART 7 ONLY.

② NE107 ALERTS ARE AVAILABLE FOR HART 7. ALL HART 5 FAST-KEY SEQUENCES WILL DECREASE BY ONE NUMBER AFTER THE NE107 ALERT CONFIGURATION ENTRY.

Figure B-10. Calibration

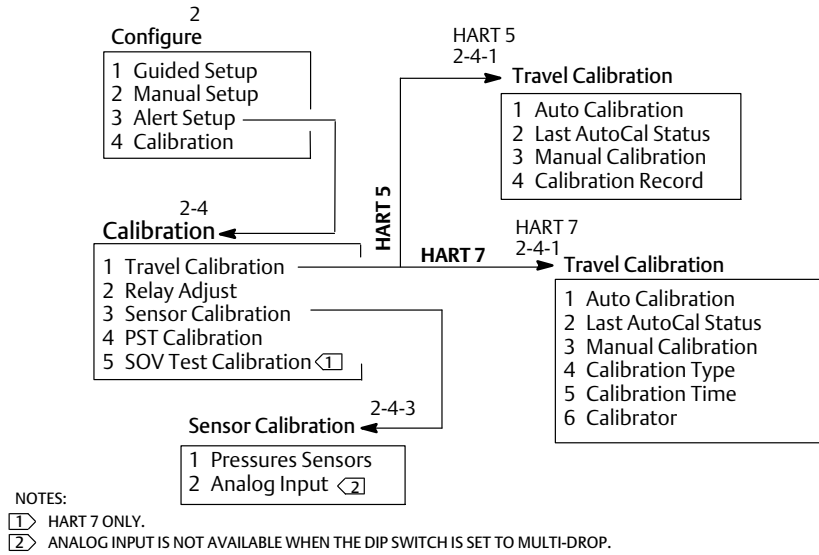
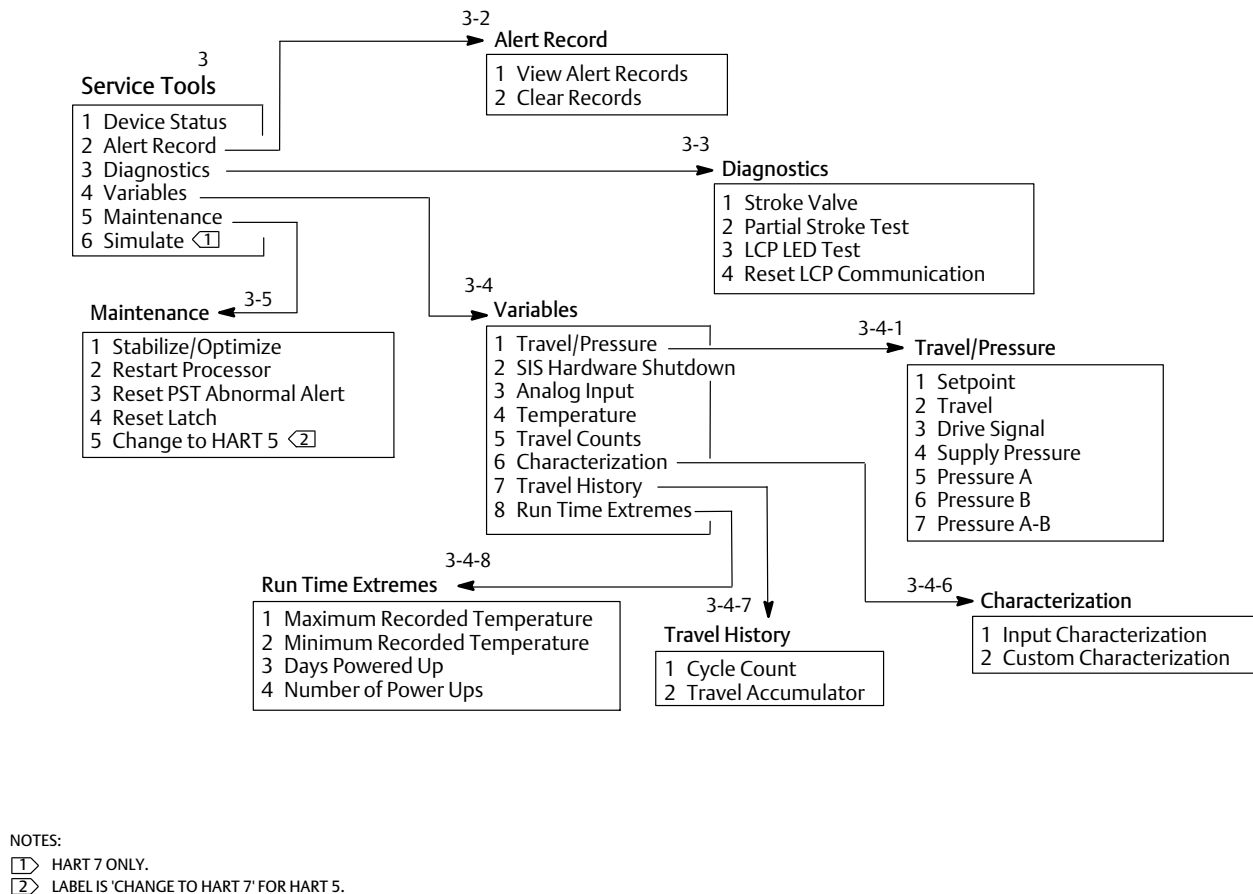

Figure B-11. Service Tools



Glossary

Alert Point

An adjustable value that, when exceeded, activates an alert.

Algorithm

A set of logical steps to solve a problem or accomplish a task. A computer program contains one or more algorithms.

Alphanumeric

Consisting of letters and numbers.

Analog Input Units

Units in which the analog input is displayed and maintained in the instrument.

ANSI (acronym)

The acronym ANSI stands for the American National Standards Institute

ANSI Class

Valve pressure/temperature rating.

Bench Set

Pressure, supplied to an actuator, required to drive the actuator through rated valve travel. Expressed in pounds per square inch.

Breakout Timeout

The user configured amount of time before which the valve must leave the normal end during a Partial Stroke test.

Byte

A unit of binary digits (bits). A byte consists of eight bits.

Calibration Location

Where the instrument was last calibrated; either in the factory or in the field.

Configuration

Stored instructions and operating parameters for a FIELDVUE Instrument.

Control Loop

An arrangement of physical and electronic components for process control. The electronic components of the loop continuously measure one or more aspects of the process, then alter those aspects as necessary to achieve a desired process condition. A simple control loop measures only one variable. More sophisticated control loops measure many variables and maintain specified relationships among those variables.

Control Mode

Defines where the instrument reads its set point. The following control modes are available for a FIELDVUE Instrument:

Analog The instrument receives its travel set point over the 4-20 mA loop.

Digital The instrument receives its set point digitally, via the HART communications link.

Test This is not a user-selectable mode. The Device Communicator or ValveLink software places the instrument in this mode whenever it needs to move the valve, such as for calibration or diagnostic tests.

Control Mode, Restart

Determines the instrument control mode after a restart. See Control Mode for the available restart control modes.

Controller

A device that operates automatically to regulate a controlled variable.

Current-to-Pressure (I/P) Converter

An electronic component or device that converts a milliamp signal to a proportional pneumatic pressure output signal.

Cycle Counter

The capability of a FIELDVUE instrument to record the number of times the travel changes direction. The change in direction must occur after the deadband has been exceeded before it can be counted as a cycle.

Cycle Counter Alert

Checks the difference between the Cycle Counter and the Cycle Counter Alert Point. Cycle Counter Alert is active when the cycle counter value exceeds the Cycle Counter Alert Point. It clears after you reset the Cycle Counter to a value less than the alert point.

Cycle Counter Alert Point

An adjustable value which, when exceeded, activates the Cycle Counter Alert. Valid entries are 0 to 4 billion cycles.

Cycle Counter Deadband

Region around the travel reference point, in percent of ranged travel, established at the last increment of the Cycle Counter. The deadband must be exceeded before a change in travel can be counted as a cycle. Valid entries are 0% to 100%. Typical value is between 2% and 5%.

Deviation

Usually, the difference between set point and process variable. More generally, any departure from a desired or expected value or pattern.

Device ID

Unique identifier embedded in the instrument at the factory.

Device Revision

Revision number of the interface software that permits communication between the Device Communicator and the instrument.

Drive Signal

The signal to the I/P converter from the printed wiring board. It is the percentage of the total microprocessor effort needed to drive the valve fully open.

Drive Signal Alert

Checks the drive signal and calibrated travel. If one of the following conditions exists for more than 20 seconds, the Drive Signal Alert is active. If none of the conditions exist, the alert is cleared. If Zero Power Condition = Closed

The alert is active when:

drive signal <10% and calibrated travel >3%

drive signal >90% and calibrated travel <97%

If Zero Power Condition = Open

The alert is active when:

drive signal <10% and calibrated travel <97%

drive signal >90% and calibrated travel >3%

Equal Percentage

A valve flow characteristic where equal increments of valve stem travel produce equal percentage changes in existing flow. One of the input characteristics available for a FIELDVUE Instrument. See also, Linear and Quick Opening.

Feedback Signal

Indicates to the instrument the actual position of the valve. The travel sensor provides the feedback signal to the instrument printed wiring board assembly.

Firmware Revision

The revision number of the instrument firmware. Firmware is a program that is entered into the instrument at time of manufacture and cannot be changed by the user.

Free Time

Percent of time that the microprocessor is idle. A typical value is 25%. The actual value depends on the number of functions in the instrument that are enabled and on the amount of communication currently in progress.

Full Ranged Travel

Current, in mA, that corresponds with the point where ranged travel is maximum, i.e., limited by the mechanical travel stops.

Gain

The ratio of output change to input change.

Hardware Revision

Revision number of the Fisher instrument hardware. The physical components of the instrument are defined as the hardware.

HART (acronym)

The acronym HART stands for Highway Addressable Remote Transducer.

HART Universal Revision

Revision number of the HART Universal Commands which are the communications protocol for the instrument.

Incoming Ramp Rate

The rate at which the valve will move during the Incoming stroke of the Partial Stroke test. The default value is 0.25%/second.

Input Characteristic

The relationship between the ranged travel and ranged input. Possible values include: linear, equal percentage, and quick opening.

Input Current

The current signal from the control system that serves as the analog input to the instrument. See also Input Signal.

Input Range

The analog input signal range that corresponds to the travel range.

Input Signal

The current signal from the control system. The input signal can be displayed in milliamperes or in percent of ranged input.

Instrument Level

Determines the functions available for the instrument.

Instrument Mode

Determines if the instrument responds to its analog input signal. There are two instrument modes:

In Service: For a fully functioning instrument, the instrument output changes in response to analog input changes. Typically changes to setup or calibration cannot be made when the instrument mode is In Service.

Out of Service: The instrument output does not change in response to analog input changes when the instrument mode is Out of Service. Some setup parameters can be changed only when the instrument mode is Out of Service.

Instrument Protection

Determines if commands from a HART device can calibrate and/or configure certain parameters in the instrument. There are two types of instrument protection:

Configuration and Calibration: Prohibits changing protected setup parameters; prohibits calibration.

None: Permits both configuration and calibration. The instrument is "unprotected."

Instrument Serial Number

The serial number assigned to the printed wiring board by the factory but can be changed during setup. The instrument serial number should match the serial number on the instrument nameplate.

Leak Class

Defines the allowable leakage by a valve when it is closed. Leak class numbers are listed in two standards: ANSI/FCI 70-2 and IEC 534-4.

Linear

A valve flow characteristic where changes in flow rate are directly proportional to changes in valve stem travel. One of the input characteristics available for a FIELDVUE Instrument. See also, Equal Percentage and Quick Opening.

Linearity, dynamic

Linearity (independent) is the maximum deviation from a straight line best fit to the opening and closing curves and a line representing the average value of those curves.

Memory

A type of semiconductor used for storing programs or data. FIELDVUE instruments use three types of memory: Random Access Memory (RAM), Read Only Memory (ROM), and Non-Volatile Memory (NVM). See also these listings in this glossary.

Menu

A list of programs, commands, or other activities that you select by using the arrow keys to highlight the item then pressing ENTER, or by entering the numeric value of the menu item.

Minimum Closing Time

Minimum time, in seconds, for the travel to decrease through the entire ranged travel. This rate is applied to any travel decrease. Valid entries are 0 to 400 seconds. Deactivate by entering a value of 0 seconds.

Minimum Opening Time

Minimum time, in seconds, for the travel to increase through the entire ranged travel. This rate is applied to any travel increase. Because of friction, actual valve travel may not respond in exactly the same time frame. Valid entries are 0 to 400 seconds. Deactivate by entering a value of 0 seconds.

Non-Volatile Memory (NVM)

A type of semiconductor memory that retains its contents even though power is disconnected. NVM contents can be changed during configuration unlike ROM which can be changed only at time of instrument manufacture. NVM stores configuration restart data.

Outgoing Ramp Rate

The rate at which the valve will move during the Outgoing stroke of the Partial Stroke test. The default value is 0.25%/second.

Parallel

Simultaneous: said of data transmission on two or more channels at the same time.

Partial Stroke Test (PST)

The process of taking the valve from the normal end to a target position at a preconfigured ramp rate before returning to the normal end while gathering data

Pause Time

The time between the outgoing and incoming strokes of the Partial Stroke test. The default value is 5 seconds.

Polling Address

Address of the instrument. If the digital valve controller is used in a point-to-point configuration, set the polling address to 0. If it is used in a multidrop configuration, or split range application, set the polling address to a value from 0 to 15 for HART 5, and 0 to 63 for HART 7.

Pressure Sensor

A FIELDVUE instrument internal device that senses pneumatic pressure. The DVC6200 SIS has three pressure sensors: one to sense supply pressure and two to sense the output pressures.

Primary Master

Masters are communicating devices. A primary master is a communicating device permanently wired to a field instrument. Typically, a HART-compatible control system or a computer running ValveLink software is the primary master. In contrast, a secondary master is not often permanently wired to a field instrument. The Device Communicator or a computer running ValveLink software communicating through a HART modem could be considered a secondary master.

Note: If one type of master takes an instrument Out Of Service, the same type must put it In Service. For example, if a device set up as a primary master takes an instrument Out Of Service, a device set up as a primary master must be used to place the instrument In Service.

Quick Opening

A valve flow characteristic where most of the change in flow rate takes place for small amounts of stem travel from the closed position. The flow characteristic curve is basically linear through the first 40 percent of stem travel. One of the input characteristics available for a FIELDVUE Instrument. See also, Equal Percentage and Linear.

Ramp Rate

See Incoming Ramp Rate and Outgoing Ramp Rate definitions.

Random Access Memory (RAM)

A type of semiconductor memory that is normally used by the microprocessor during normal operation that permits rapid retrieval and storage of programs and data. See also Read Only Memory (ROM) and Non-Volatile Memory (NVM).

Rate

Amount of change in output proportional to the rate of change in input.

Read-Only Memory (ROM)

A memory in which information is stored at the time of instrument manufacture. You can examine but not change ROM contents.

Return Lead

The percent (%) change in setpoint required to overcome the hysteresis in the valve assembly during a Partial Stroke test. The error between setpoint and actual error is added to this percent change.

Seat Load

Force exerted on the valve seat, typically expressed in pounds force per lineal inch of port circumference. Seat load is determined by shutoff requirements.

Set Point Filter Time (Lag Time)

The time constant, in seconds, for the first-order input filter. The default of 0 seconds will bypass the filter.

Short Duration PST

During a Partial Stroke test, allows the incoming stroke to be initiated as soon as the travel reaches the minimum travel movement.

Software

Microprocessor or computer programs and routines that reside in alterable memory (usually RAM), as opposed to firmware, which consists of programs and routines that are programmed into memory (usually ROM) when the instrument is manufactured. Software can be manipulated during normal operation, firmware cannot.

Stroke Time

The DVC6200 SIS calculates the time it takes to fully stroke in the event of a demand and stores the last value. In order for the calculation to occur, the Travel Hi Hi and Travel Lo Lo alert points must be configured to 99% and 1% respectively. Stroke time can be read from the device with ValveLink software.

Stroking Time

The time, in seconds, required to move the valve from its fully open position to fully closed, or vice versa.

Temperature Sensor

A device within the FIELDVUE instrument that measures the instrument's internal temperature.

Test Start Point

The normal (not tripped) end of valve travel. The valve must be at this end for a Partial Stroke test to be initiated.

Travel

Movement of the valve stem or shaft which changes the amount the valve is open or closed.

Travel Accumulator

The capability of a FIELDVUE instrument to record total change in travel. The value of the Travel Accumulator increments when the magnitude of the change exceeds the Travel Accumulator Deadband. To reset the Travel Accumulator, set it to zero.

Travel Accumulator Alert

Checks the difference between the Travel Accumulator value and the Travel Accumulator Alert Point. The Travel Accumulator Alert is active when the Travel Accumulator value exceeds the Travel Accumulator Alert Point. It clears after you reset the Travel Accumulator to a value less than the alert point.

Travel Accumulator Alert Point

An adjustable value which, when exceeded, activates the Travel Accumulator Alert. Valid entries are 0% to 4 billion %.

Travel Accumulator Deadband

Region around the travel reference point established at the last increment of the accumulator. This region must be exceeded before a change in travel can be accumulated. Valid entries are 0% to 100%.

Travel Alert

Checks the ranged travel against the travel high and low alert points. The travel alert is active if either the high or low point is exceeded. Once a high or low point is exceeded, the ranged travel must clear that point by the Travel Alert Deadband before the alert clears. Four travel alerts are available: Travel Alert Hi, Travel Alert Lo, Travel Alert Hi Hi, and Travel Alert Lo Lo.

Travel Alert Deadband

Travel, in percent of ranged travel, required to clear a travel alert, once it is active. Valid entries are -25% to 125%.

Travel Alert High Point

Value of the travel, in percent of ranged travel, which, when exceeded, sets the Travel Alert Hi alert. Valid entries are -25% to 125%.

Travel Alert High High Point

Value of the travel, in percent of ranged travel, which, when exceeded, sets the Travel Alert Hi Hi alert. Valid entries are -25% to 125%.

Travel Alert Low Point

Value of the travel, in percent of ranged travel, which, when exceeded, sets the Travel Alert Lo alert. Valid entries are -25% to 125%.

Travel Alert Low Low Point

Value of the travel, in percent of ranged travel, which, when exceeded, sets the Travel Alert Lo Lo alert. Valid entries are -25% to 125%.

Travel Cutoff

Defines the cutoff point for the travel, in percent of ranged travel. There are two travel cutoffs: high and low. Once travel exceeds the cutoff, the drive signal is set to either maximum or minimum, depending on the Zero Control Signal and if the cutoff is high or low. Minimum opening time or minimum closing time are not in effect while the travel is beyond the cutoff. Use the travel cutoff to obtain the desired seat load or to be sure the valve is fully open.

Travel Deviation

The difference between the analog input signal (in percent of ranged input), the “target” travel, and the actual “ranged” travel.

Travel Deviation Alert

Checks the difference between the target and the ranged travel. If the difference exceeds the Travel Deviation Alert Point for more than the Travel Deviation Time, the Travel Deviation Alert is active. It remains active until the difference is less than the Travel Deviation Alert Point.

Travel Deviation Alert Point

An adjustable value for the target travel and the ranged travel difference, expressed in percent. When this value is exceeded by the travel deviation for more than the Travel Deviation Time, the Travel Deviation Alert is active. Valid entries are 0% to 100%. Typically this is set to 5%.

Travel Deviation Time

The time, in seconds, that the travel deviation must exceed the Travel Deviation Alert Point before the alert is active. Valid entries are 1 to 60 seconds.

Travel Limit

A setup parameter that defines the maximum allowable travel (in percent of ranged travel) for the valve. During operation, the travel target will not exceed this limit. There are two travel limits: high and low. Typically the travel limit low will be used to keep the valve from going completely closed.

Travel Range

Travel, in percent of calibrated travel, that corresponds to the input range.

Travel Sensor

A device within the FIELDVUE instrument that senses valve stem or shaft movement. The travel sensor in the DVC6200 SIS is the Hall Effect sensor that measures the position of the magnetic assembly.

Travel Sensor Motion

Increasing or decreasing air pressure causes the magnet assembly to move up or down or the rotary shaft to turn clockwise or counterclockwise. The Setup Wizard asks if it can move the valve to determine travel.

Tuning

The adjustment of control terms or parameter values to produce a desired control effect.

Tuning Set

Preset values that identify gain settings for a FIELDVUE instrument. The tuning set and supply pressure together determine an instrument's response to input signal changes.

Watch Dog Timer

A timer that the microprocessor must rearm periodically. If the microprocessor is unable to rearm the timer, the instrument goes through reset.

Zero Power Condition

The position of the valve (open or closed) when the electrical power to the instrument is removed. Zero Power Condition (ZPC) is determined by relay and actuator action as follows:

Single Acting Direct (Relay C) Upon loss of electrical power instrument goes to zero air output at port A.

Double Acting (Relay A) Upon loss of electrical power instrument goes to full supply air output at port B. A goes to zero air output.

Single Acting Reverse (Relay B) Upon loss of electrical power instrument goes to full supply air output at Port B.

Index

A

- Action on Failed Test, 32
- Actuator Compatibility
 - Quarter-Turn Rotary, 6
 - Sliding-Stem Linear, 6
- Actuator Style, 24
- Air, as supply medium, 5
- Air Consumption, Steady State, 5
- Alert Record, 48
- Alert Record Full, 49
- Alert Record Not Empty, 49
- Alert Reporting, 48
- Alert Settings, Default, 48
- Alert Setup, 36
- Alert Switch, Function, 34
- Alert Switch Source, 35
- Analog Calibration Adjust, 39
- Analog Input Units, 18
- ANSI/ISA S75.13.01 Section 5.3.5, 6
- ATEX, Hazardous Area Approvals, 6
- Auto Calibration, 15, 38
 - Error Messages, 38
- Auto Partial Stroke Test, 54
- Autocal in Progress, 49
- Autocalibrate
 - Advanced Settings, 15
 - Standard, 15
 - Without Biases, 15
- Auxiliary Terminal, Wiring Length Guidelines, 12
- Auxiliary Terminal Action, 18
- Auxiliary Terminal Contact, Electrical Classification, 6

B

- Breakout Timeout, 28
- Burst Mode, 35

C

- Calibration, 37
 - Analog Input, 42
 - Pressure Sensors, 41
 - PST, 45
 - Pushbutton, 40
 - Relay Adjustment, 43
 - Sensor, 41
 - SOV Test, 45
 - Travel, 38
 - Auto, 38
 - Manual, 39
- Calibration (CAL) Button, 18
- Calibration in Progress, 49
- Certification Management Limited (CML), Japan, Certifications, 6
- Certifications
 - CCC, China Compulsory Certification, 6
 - CML, Japan, 6
 - CUTR, Russia, Kazakhstan, Belarus, and Armenia, 6
 - ESMA, United Arab Emirates, 6
 - INMETRO, Brazil, 6
 - KOSHA, South Korea, 6
 - KTL, South Korea, 6
 - Lloyds Register, 6
 - NESPI, China, 6
 - PESO CCOE, India, 6
 - SANS, South Africa, 6
- Characterization, 19
 - Custom Characterization, 19
 - Input Characterization, 19
- China Compulsory Certification (CCC), Classifications/Certifications, 6
- Compliance Voltage, 10
- Configuration, Initial, 3
- Connections, 6
 - Electrical, 3
 - Pneumatic, 3
- Construction Materials, 7
- Critical NVM Failure, 49
- CSA, Hazardous Area Approvals, 6
- Custom Characterization, Defining, 19
- Customs Union Technical Regulations (CUTR), Russia, Kazakhstan, Belarus, and Armenia, Certifications, 6
- Cycle Counter High, 49

D

Deadband, Principle of Operation, 52
 Declaration of SEP, 7
 Default Parameters, Detailed Setup, 15
 Demand Mode Tests, 55
 Point-to-Point Mode, 55
 when LCP100 is used, 56
 Descriptor, 17
 Device Communicator, Partial Stroke Test, 55
 Device Communicator Menu Trees, 89
 Device Diagnostics, 48
 Device Information, 47
 Device Status, 48
 Diagnostic Data Available, 49
 Diagnostics, 54
 Partial Stroke Test, 54
 Stroke Valve, 54
 Diagnostics in Progress, 49
 Digital Calibration Adjust, 39
 DIP Switch, setting, 67
 Drive Current Failure, 49
 Drive Signal Alert, 50
 Dynamic Response, 20
 Lag Time, 21
 SP Rate Close, 20
 SP Rate Open, 20

E

Edit Instrument Time, 18
 Educational Services, 8
 Electrical Connection, 6
 Electrical Connections, 3
 LCP100 local control panel, 13
 LCP200 local control panel, 13
 Electrical Housing, Classification, 6
 Electromagnetic Compatibility, 6
 EMC Summary Results, Immunity, 7
 Emergency Mode Tests, Multidrop Mode, 56
 Emirates Authority for Standardization and Metrology
 (ESMA), United Arab Emirates, Certifications, 6

EN 61326-1, 6
 End Point Pressure Control (EPPC), 19
 End Point Pressure Control Tuning, 19
 End Point Pressure Deviation, 50
 EPPC Enable, 19
 EPPC Saturation Time, 19
 EPPC Set Point, 19
 Expert tuning, travel tuning, 22

F

Fail Signal, Output Terminal Configuration, 34
 Fast Key Sequences, Device Communicator, 89
 Feedback Connection, 24
 Field Device Malfunction, 50
 Flash Integrity Failure, 50
 FM, Hazardous Area Approvals, 6
 frequency shift keying (FSK), 85
 Function, Output Terminal Configuration
 Alert Switch, 34
 Limit Switch, 34
 Transmitter, 34

G

Gain Values, Travel Tuning Sets, 21
 Gauges, maintenance, 69
 Guided Setup, 15

H

HART Command 48, 48
 HART Communication, principle of operation, 85
 HART Filter, 9
 HART Long Tag, 17
 HART Tag, 17
 HART Universal Revision, changing, 36
 HART Variable Assignments, 35
 Hazardous Area Approvals, 6
 ATEX, 6
 CSA, 6
 FM, 6
 IECEX, 6

Hi Cutoff Select, 21

Hi Cutoff Point, 21

I

I/P Converter

 maintenance, 65

 removing, 66

 replacing, 66

I/P Filter, replacing, 65

IEC 61010, Compliance Requirements, 6

IECEX, Hazardous Area Approvals, 6

Impedance, Input Load, 6

Incoming Pressure Threshold, 30

Incoming Ramp Rate, 28

Independent Linearity, Typical Value, 6

Independent SOV Test, 34

Initial Setup, actuator information, 23

Input Characterization, 19

Input Load Impedance, 6

Input Signal, 5

 Multi-Drop, 5

 Point-to-Point, 5

Installation, 3

 LCP100 (Local Control Panel), 13

 LCP200 (Local Control Panel), 13

Instrument Mode, 17

Instrument Time, Edit, 18

Instrument Time is Approximate, 50

Instrument Serial Number, 18

Integral Dead Zone, 24

Integral Enable, Travel Tuning, 22

Integral Gain, Travel Tuning, 22

Integral Setting, 24

Integral Switch

 Electronic Output, 5

 Off State, 5

 On State, 5

 Reference Accuracy, 5

 Safety Accuracy, 5

 Supply Voltage, 5

Integrator Limit, 24

Integrator Saturated High, 50

Integrator Saturated Low, 50

Internal Sensor Out of Limits, 50

ISA Standard 7.0.01, 5

ISO 8573-1, Supply Medium, 5

K

Korea Testing Laboratory (KTL), South Korea, Certifications, 6

Korean Occupational Safety & Health Agency (KOSHA), South Korea, Certifications, 6

L

Lag Time, 21

Latch on Position Trip, 32

LCP Communications Failure, 50

LCP Stuck Button, 50

LCP100 (Local Control Panel), Installation and Electrical Connections, 13

LCP200 (Local Control Panel), Installation and Electrical Connections, 13

Limit Switch, Function, 34

Limit Switch Trip Point, 34

Line Conditioner, 9

Lloyds Register, Certifications, 6

Lo Cutoff Point, 21

Lo Cutoff Select, 21

Logic Solver, Control System Requirements, 9

Loop Current Validation Alert, 50

Loop-Initiated PST, 32

Low Bleed Relay, Steady State Air Consumption, 5

M

Magnet Assembly, 24

Magnetic Feedback Assembly, removing, 62

Maintenance

 Gauges, Pipe Plugs, or Tire Valves, 69

 I/P Converter, 65

 module base, 62

 Pneumatic Relay, 68

- Printed Wiring Board Assembly, 67
 - Terminal Box, 69
 - tools required, 62
 - Maintenance and Troubleshooting, 61
 - Manual Calibration, 39
 - Manual Reset Required , 51
 - Manual Setup, 15
 - Maximum Cable Capacitance, 11
 - maximum supply pressure, 26
 - Message, 17
 - Minimum Travel Movement, 28
 - Minor Loop Sensor Failure, 50
 - MLFB Gain, Travel Tuning, 22
 - Mode, Burst, 35
 - Module Base
 - removing, 63
 - replacing, 64
 - Module Base Maintenance, 62
 - Monitoring Time, 33
 - multi-drop mode (0-24 VDC power supply),
 - configurations, 16
- ## N
- NAMUR NE43, 5
 - National Institute of Metrology, Quality, and Technology (INMETRO), Brazil, Certifications, 6
 - National Supervision and Inspection Centre for Explosion Protection and Safety of Instrumentation (NEPSI), China, Certifications, 6
 - natural gas, as supply medium, 5, 61
 - NE107 Category, Alert Settings, 48
 - Non-Critical NVM, 50
- ## O
- Off State, Integral Switch, 5
 - Offline / Failed , 50
 - On Abnormal SOV Test, 34
 - On State, Integral Switch, 5
 - Options, 7
 - Outgoing Pressure Threshold, 29
 - Outgoing Ramp Rate, 28
 - Output Capacity, Maximum, 5
 - Output Circuit Error , 50
 - Output Pressure Connection, 6
 - Output Pressure Limit Enable, 26
 - Output Pressure Sensor, Calibration, 41
 - Output Signal, 5
 - Electronic Output, 5
 - Pneumatic Output, 5
 - Output Terminal Configuration, 34
 - Output Terminal Enable, 34
 - Output Terminal Function, to support SOV Testing, 33
 - Outputs, 34
 - Burst Mode, 35
 - HART Variable Assignments, 35
 - Output Terminal Configuration, 34
 - Switch Configuration, 34
 - Transmitter Output, 35
 - Overview, 47
 - Device, 59
 - Status & Primary Purpose Variables, 47
- ## P
- Partial Stroke Parameters, 28
 - Breakout Timeout, 28
 - Incoming Pressure Threshold, 30
 - Incoming Ramp Rate, 28
 - Minimum Travel Movement, 28
 - Outgoing Pressure Threshold, 29
 - Outgoing Ramp Rate, 28
 - Return Lead, 28
 - Short Duration PST, 28
 - Partial Stroke Test
 - Automatic (scheduled), 54
 - Device Communicator, 55
 - Local Control Panel, 54
 - Local Pushbutton, 54
 - Partial Stroke Test (PST), 27
 - Partial Stroke Test (PST)
 - Abnormal Criteria, 30
 - Abort Criteria, 31
 - Prohibited, 31
 - Parts
 - Kits, 75
 - List, 76
 - ordering, 75

Petroleum and Explosives Safety Organisation - Chief
Controller of Explosives (PESO CCOE), India,
Certifications, 6

Pipe Plugs, maintenance, 69

Pneumatic Connections, 3

Pneumatic Relay
maintenance, 68
removing, 68
replacing, 68

point-to-point mode (4-20 mA input current),
configurations, 16

Polling Address, 17

Port A Overpressurized, 51

Position Transmitter
Electronic Output, 5
Reference Accuracy, 5
Safety Accuracy, 5
Supply Voltage, 5

Position Trip Point, 32

Pressure Fallback Active, 51

Pressure Sensor Failure , 51

Pressure Sensors, Calibration, 41

Pressure Units, 18

Primary Variable (PV), 35

Principle of Operation
DVC6200, 85
HART Communication, 85

Printed Wiring Board Assembly
maintenance, 67
removing, 67
replacing, 67

Proportional Gain, Travel Tuning, 22

PST Abnormal, 51

PST Calibration, 45

PST Pass, 51

PST Prohibited, 51

PST Trip Point (DETT) , 32

PST Trip Point (ETT), 32

Pulse Duration, 33

Pushbutton Calibration, 40

Q

Quaternary Variable (QV), 35

R

Reference Accuracy
Integral Switch, 5
Position Transmitter, 5

Reference Voltage Failure, 51

Related Documents, 7

Relay Adjustment, 43

Relay Type, 25
to Support SOV Testing, 33

Reset Pressure Differential, 34

Restart Processor, 71

Return Lead, 28

RShaft End Mount, Magnet Assembly, 24

RShaft Window #1, Magnet Assembly, 24

RShaft Window #2, Magnet Assembly, 24

S

Safety Accuracy
Integral Switch, 5
Position Transmitter, 5

Secondary Variable (SV), 35

Sensor Calibration, 41

Serial Number
Instrument, 18
Valve, 18

Service Tools, 48
Device Status, 48

Set Point Filter Time, 21

Short Duration PST, 28

SIS Hardware Failure, 51

SIS Options, 32
Action on Failed Test, 32
Change Reset Mode, 32
Auto Reset, 32
Manual Reset, 32
Smart Auto Reset, 32
Loop-Initiated PST, 32
PST Trip Point (DETT), 32
PST Trip Point (ETT), 32

- SIS Program Flow Failure, 51
- SIS Stroke Performance, 51
- Solenoid Valve, Health Monitoring, 59
- Solenoid Valve Test, 32
 - Instrument Configuration to Support, 33
- South Africa National Standards (SANS), Certifications, 6
- SOV Test
 - Calibration, 45
 - Function, 34
- SOV Test Alerts, 34
 - Reset Pressure Alert Point, 34
 - Trip Pressure Alert Point, 34
- SOV Test before PST, 34
- SOV Test Parameters, 33
 - Independent SOV Test, 34
 - Monitoring Time, 33
 - On Abnormal SOV Test, 34
 - Pulse Duration, 33
 - Reset Pressure Differential, 34
 - SOV Test before PST, 34
 - Trip Pressure Differential, 33
- SOV Testing, Instrument Configuration to Support
 - Output Terminal Function, 33
 - Relay Type, 33
- SP Rate Close, 20
- SP Rate Open, 20
- Spec Sheet, 18
- Special App, 25
- Specifications, 4
- SStem #1 Roller, Magnet Assembly, 24
- SStem #100, Magnet Assembly, 24
- SStem #19, Magnet Assembly, 24
- SStem #210, Magnet Assembly, 24
- SStem #25, Magnet Assembly, 24
- SStem #38, Magnet Assembly, 24
- SStem #50, Magnet Assembly, 24
- SStem #7, Magnet Assembly, 24
- Stabilize/Optimize, 22
- Status & Primary Purpose Variables, Device Information, 47
- Stroke Valve, 54

- Supply Medium, 5
 - per ISO 8573-1, 5
- Supply Pressure, 5
- Supply Pressure Connection, 6
- Supply Pressure High, 51
- Supply Pressure Low, 51
- Supply Pressure Sensor, Calibration, 42
- Supply Voltage
 - Integral Switch, 5
 - Position Transmitter, 5
- Switch Closed, 35
- Switch Configuration, 34
 - Alert Switch Source, 35
 - Limit Switch Trip Point, 34
 - Switch Closed, 35

T

- Technical Support Checklist, 74
- Temperature Limits, Operating Ambient, 5
- Temperature Sensor Failure, 51
- Temperature Units, 18
- Terminal Box, 18
 - Auxiliary Terminal Action, 18
 - Calibration (CAL) Button, 18
 - maintenance, 69
 - removing, 70
 - replacing, 70
- Tertiary Variable (TV), 35
- Tire Valves, maintenance, 69
- Transmitter, Function, 34
- Travel Accumulator High, 51
- Travel Alert Hi, 52
- Travel Alert Hi-Hi, 52
- Travel Alert Lo, 52
- Travel Alert Lo-Lo, 52
- Travel Calibration, 38
- Travel Cutoff Hi, 52
- Travel Cutoff Lo, 52
- Travel Cutoffs, 21
 - Hi Cutoff Point, 21
 - Lo Cutoff Point, 21
- Travel Deviation, 52

Travel Sensor Failure, 52

Travel Sensor Motion, 25

Travel Tuning, 21
 Stabilize/Optimize, 22

Travel Tuning Set, 21

Travel Tuning Sets, Gain Values, 21

Travel/Pressure Control, 19
 End Point Pressure Control, 19
 Travel Cutoffs, 21

Trip Pressure Differential, 33

Tripped by the LCP, 52

Troubleshooting
 Checking Voltage Available, 71
 Communications or Output, 71
 instrument, 72

Tubing Connection, 6

Tuning, 21
 Travel, 21

Tuning Set, Travel, 21

U

Units
 Analog Input, 18
 Pressure, 18
 Temperature, 18

V

Valve Serial Number, 18

Valve Style, 24

Variable out of Range, 52

Variables, Status & Primary Purpose, 47

Velocity Gain, Travel Tuning, 22

Vent Connection, 6

Vibration, Testing Method, 6

Voltage Available, 9
 checking, 71

W

Weight
 DVC6200 SIS, 6
 DVC6205 SIS, 6
 DVC6215, 6

Wiring Practices, 9
 Control System Requirements, 9
 Compliance Voltage, 10
 HART Filter, 9
 Line Conditioner, 9
 Voltage Available, 9
 Maximum Cable Capacitance, 11

Write Protection, 17

Z

Zero Power Condition, 25



Neither Emerson, Emerson Automation Solutions, nor any of their affiliated entities assumes responsibility for the selection, use or maintenance of any product. Responsibility for proper selection, use, and maintenance of any product remains solely with the purchaser and end user.

Fisher, FIELDVUE, ValveLink, PROVOX, Rosemount, DeltaV, and RS3 are marks owned by one of the companies in the Emerson Automation Solutions business unit of Emerson Electric Co. Emerson Automation Solutions, Emerson, and the Emerson logo are trademarks and service marks of Emerson Electric Co. HART is a registered trademark of FieldComm Group. All other marks are the property of their respective owners.

The contents of this publication are presented for informational purposes only, and while every effort has been made to ensure their accuracy, they are not to be construed as warranties or guarantees, express or implied, regarding the products or services described herein or their use or applicability. All sales are governed by our terms and conditions, which are available upon request. We reserve the right to modify or improve the designs or specifications of such products at any time without notice.

Emerson Automation Solutions
Marshalltown, Iowa 50158 USA
Sorocaba, 18087 Brazil
Cernay, 68700 France
Dubai, United Arab Emirates
Singapore 128461 Singapore

www.Fisher.com

