



**05T / 06T SCREW COMPRESSOR APPLICATION GUIDE**



# Contents

---

## Introduction

|                                     |   |
|-------------------------------------|---|
| Summary of Control Points.....      | 1 |
| 06T Model Number Significance.....  | 2 |
| Compressor Physical Dimensions..... | 2 |

## Section 1 — General Information

|   |   |
|---|---|
| 1.1 Certification.....                      | 4 |
| 1.2 Screw Compressor Size (Displacement)... | 4 |
| 1.3 Compressor Mounting.....                | 4 |
| 1.4 Oil Type.....                           | 4 |
| 1.5 Ambient Conditions.....                 | 5 |
| 1.6 Installation Environment.....           | 5 |
| 1.7 Pressure Relief Valve.....              | 5 |
| 1.8 Discharge Check Valve.....              | 5 |
| 1.9 Compressor Inlet Screens.....           | 5 |
| 1.10 Service Valves.....                    | 5 |
| 1.11 Condenser Pressure Control.....        | 5 |

## Section 2 — Operating Specifications

|  |    |
|--|----|
| 2.1 Operational Envelopes.....             | 6  |
| 2.2 Vapor Temperature Limits.....          | 7  |
| 2.3 Minimum Oil Pressure Differential..... | 7  |
| 2.4 Operating Speed Ranges.....            | 7  |
| 2.5 Inverters and Refrigerants.....        | 8  |
| 2.6 Compressor Cycling.....                | 8  |
| 2.7 Mechanical Unloading.....              | 9  |
| 2.8 High Discharge Pressure Control.....   | 9  |
| 2.9 Low Suction Pressure Cut Out.....      | 9  |
| 2.10 Volume Index (Vi) Control.....        | 9  |
| 2.11 Reverse Rotation Protection.....      | 10 |
| 2.12 Mufflers.....                         | 10 |

## Section 3 — Oil Management System

|   |    |
|---|----|
| 3.1 Oil Separator.....                      | 11 |
| 3.2 Piping Configuration.....               | 12 |
| 3.3 System Oil Charge.....                  | 12 |
| 3.4 Oil Level Switch.....                   | 12 |
| 3.5 Oil Pressure Protection.....            | 13 |
| 3.6 Oil Solenoids.....                      | 13 |
| 3.7 Oil Cooling Systems.....                | 14 |
| 3.8 Oil Cooler Selection.....               | 16 |
| 3.9 Oil Filter.....                         | 20 |
| 3.10 Oil Sump Heaters.....                  | 20 |
| 3.11 Oil Sight Glass.....                   | 20 |
| 3.12 Oil System Schematics.....             | 21 |
| 3.13 Oil Line Manifold Selection Table..... | 22 |

## Section 4 — Refrigerant Management System

|  |    |
|--|----|
| 4.1 Suction and Interstage Piping..... | 23 |
|--|----|

## Section 5 — Electrical Specifications

|  |    |
|--|----|
| 5.1 Thermal Protection.....                | 25 |
| 5.2 Screw Compressor Motor Protection..... | 26 |
| 5.3 Circuit Breaker Tables.....            | 27 |

## Section 6 — Motor and Discharge Temperature Control

|  |    |
|--|----|
| 6.1 Carlyle Electronic Module (CEM)..... | 29 |
| 6.2 Discharge Temperature Control.....   | 29 |
| 6.3 Motor Cooling Control.....           | 29 |

## Section 7 — Subcooler Selection and Performance Data Adjustment

|                                |    |
|--------------------------------|----|
| 7.1 Subcooler Selection.....   | 30 |
| 7.2 Subcooling Correction..... | 30 |
| 7.3 Superheat Correction.....  | 30 |
| 7.4 Carlyle Software.....      | 30 |

## Section 8 — 05T Open Drive Application Information

|                                    |    |
|------------------------------------|----|
| 8.1 General Information.....       | 31 |
| 8.2 Compressor Dimensions.....     | 31 |
| 8.3 Compressor C-Flange.....       | 31 |
| 8.4 Compressor Coupling.....       | 31 |
| 8.5 Overall Dimensions.....        | 31 |
| 8.6 Carlyle Electronic Module..... | 36 |
| 8.7 Motor Selection.....           | 36 |
| 8.8 Performance Factors.....       | 37 |

## Section 9 — Start-Up Procedure

|                                      |    |
|--------------------------------------|----|
| 9.1 Oil Charging Procedure.....      | 38 |
| 9.2 Testing the Control Circuit..... | 38 |
| 9.3 Pre-Start-Up Check List.....     | 38 |
| 9.4 Start-Up Worksheet.....          | 39 |

## Section 10 — Accessory Part Numbers

### Appendix A LonCEM — Electronic Module

### Appendix B Original CEM — Electronic Module

# Introduction

---

This manual is for the application of the Carlyle 06T semi-hermetic and 05T open drive twin screw compressors. The operational limits, required accessories and operational guidelines are contained in this manual and must be complied with to stay within the compressor warranty guidelines.

The Carlyle 06T and 05T screw compressors are gear-driven twin screw compressors. The gear drive yields the benefits of light weight and small cubic volume. One of the key features of the Carlyle screw compressor is that all the semi-hermetic models have the same physical dimensions and port locations, as do all the open drive models.

The compressors range between 15 and 75 nominal horsepower, and are designed for use in commercial refrigeration, process cooling, environmental chamber, and air conditioning applications.

The 06T and 05T screw compressors are an addition to Carlyle's line of soft compression technology (rotary and scroll). Soft compression technology yields the benefits of smooth continuous pumping of refrigerant with minimal vibration. The potential for refrigerant leaks is reduced and rack vibration is minimized. The addition of variable speed drives to these compressors is an ideal complement for very tight capacity control over a wide speed range. Unlike reciprocating compressors, most models can run up to 70 Hz yielding extra capacity that may be needed on above design condition days.

This application guide is intended to set the required guidelines of system design and operation to maximize the reliability of the Carlyle 06T and 05T twin screw compressors. For applications outside the parameters listed in this guide, please contact Carlyle Application Engineering.

Unless otherwise noted, all information contained in this application guide applies to both the 06T and 05T models.

## Summary of Control Points

### Oil System:

|  |  |
|--|--|
| Maximum oil temperature entering compressor  | 190°F (88°C)                                     |
| Minimum oil temperature entering compressor  | 80°F (27°C)                                      |
| Maximum oil pressure differential across the oil filter  | 45 Psi (3 Bar) Cut-Out<br>25 Psi (1.6 Bar) Alarm |
| Minimum oil pressure differential across <i>each</i> compressor (oil inlet pressure to suction pressure) | 45 Psi (3 Bar) Cut-Out                           |

### Motor Cooling Control Per Compressor:

Refer to LonCEM/CEM Control Parameters Chart and Appendixes A & B.

### Discharge Temperature Control Per Compressor:

Refer to LonCEM/CEM Control Parameters Chart and Appendixes A & B.

### Reverse Rotation Protection Per Compressor:

LonCEM (Carlyle Electric Module) solid-state electronic module with integral reverse rotation protection.

— or —

Manual Reset Low Discharge Pressure Cut-Out (1/4" Tubing Conn.)      10" Vacuum (.33 bar)

— or —

Carlyle Approved Line/Load Phase Monitor (Optional)

Note: One of the above methods of reverse rotation protection is **required**.

### Head Pressure Control:

Minimum head pressure must be 45 psi (3 bar) above suction pressure **plus** expected pressure drop in the oil system (including the maximum pressure drop across the oil filter that is designed into the oil system before a filter change). If the system is set to cut-out compressors at 45 psid (3 bar) across the oil filters, then 90 psid (6 bar) plus any losses in the oil system between the separator and compressor is the required pressure differential from suction to discharge.

# 06T MODEL NUMBER SIGNIFICANCE

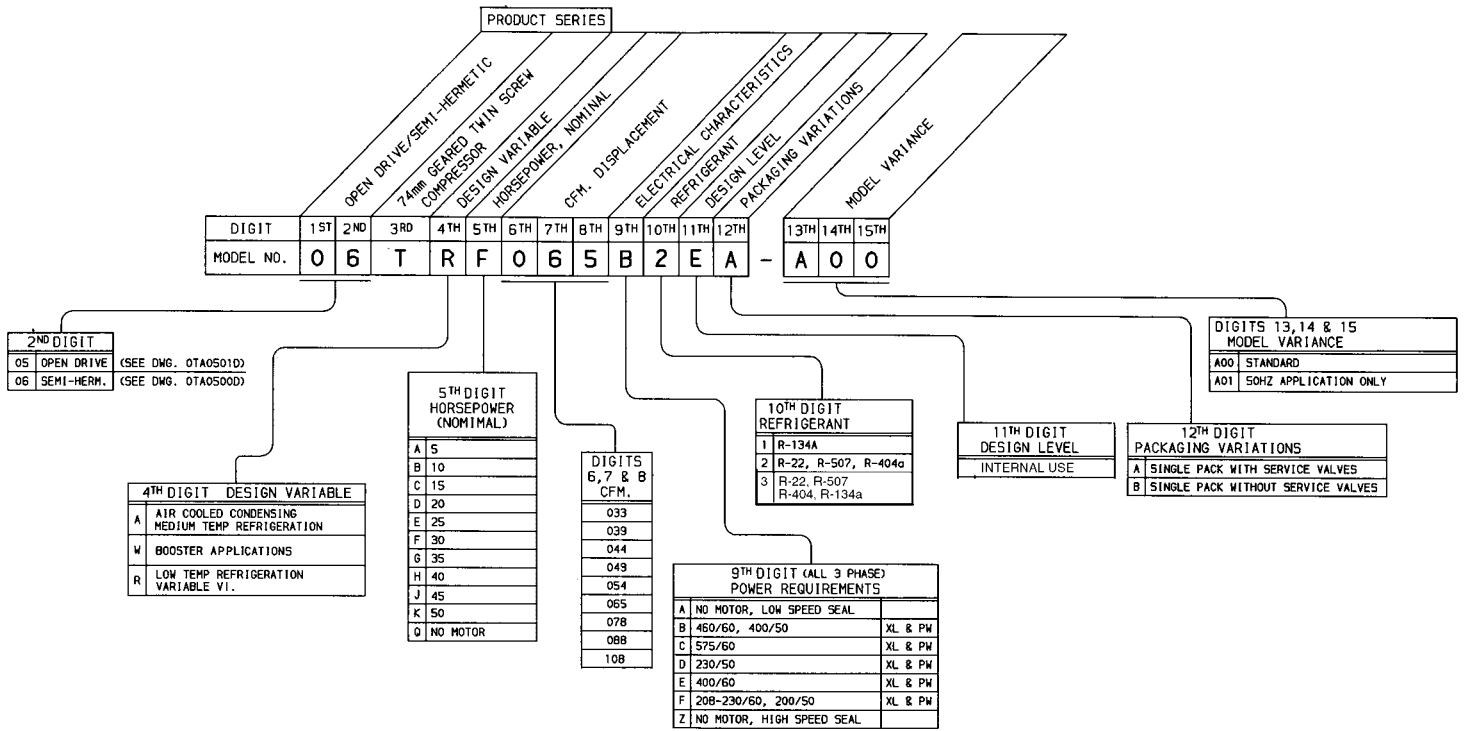

## COMPRESSOR PHYSICAL DIMENSIONS

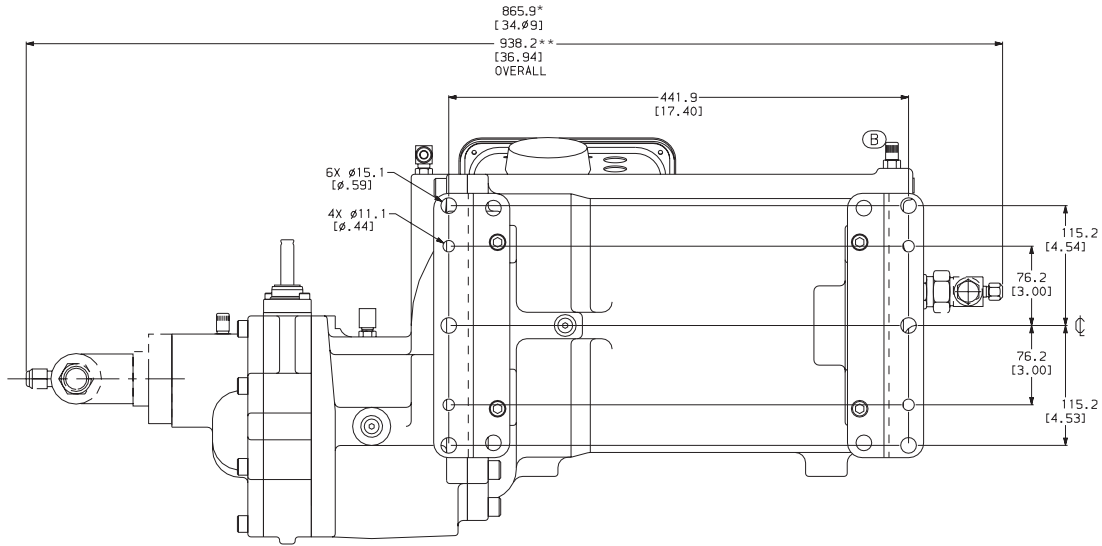

**BOTTOM VIEW**

OPTION 1: (3)  $\phi$ 15.1mm HOLES.  
OPTION 2: (4)  $\phi$ 11.1mm HOLES (FOR HARD MOUNTING ONLY).

\* Standard service valve used on all 33-54 cfm Compressors;

\*\* Larger barstock service valve used on all 65-88 cfm Compressors (shown).

FOR REFERENCE ONLY  
INCHES  
[MILLIMETERS (mm)]

# COMPRESSOR PHYSICAL DIMENSIONS CONTINUED

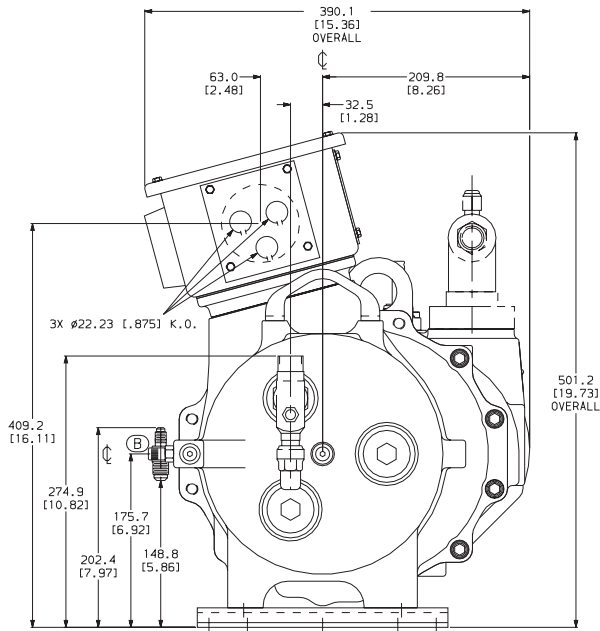

MOTOR END VIEW

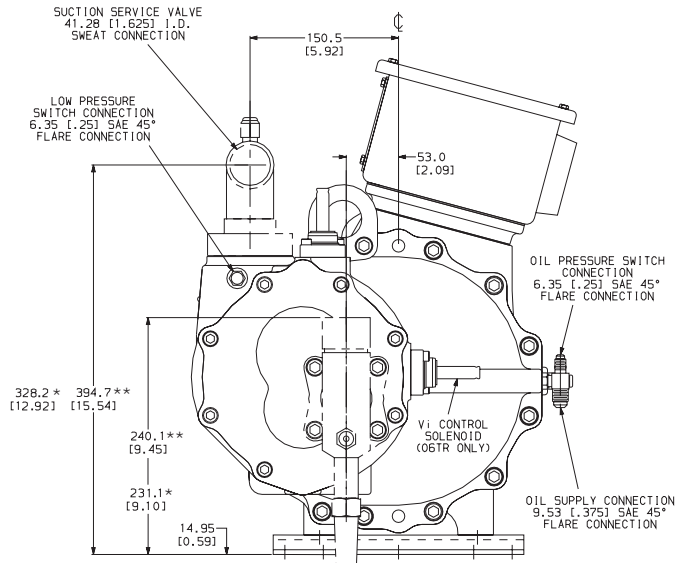

COMPRESSION END VIEW

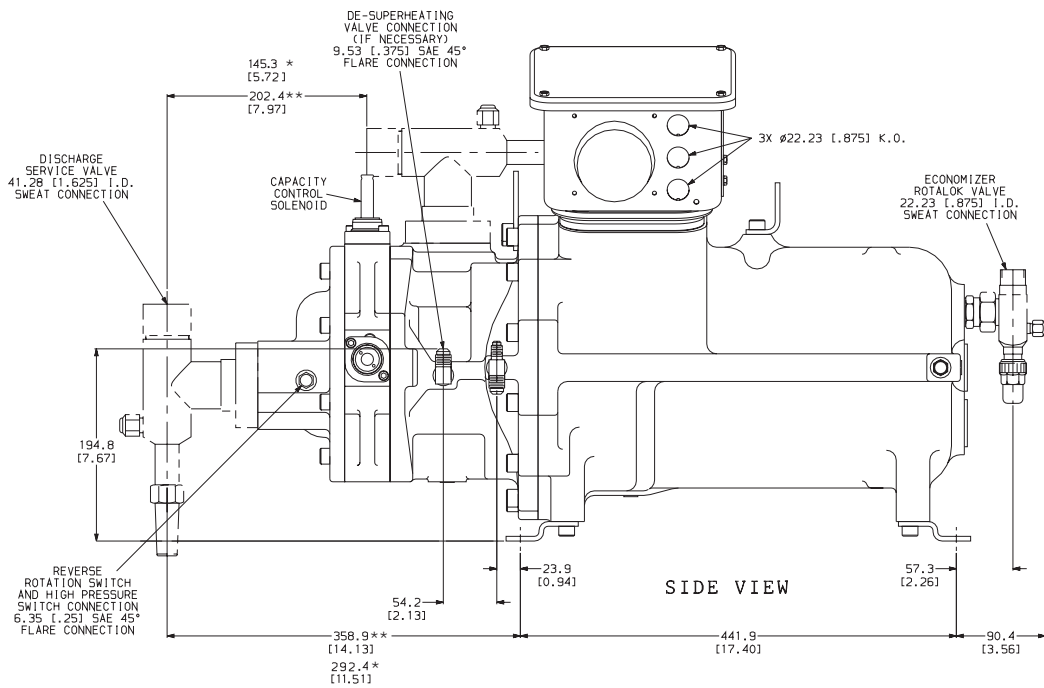

SIDE VIEW

\* Standard service valve used on all 33-54 cfm Compressors;

\*\* Larger barstock service valve used on all 65-88 cfm Compressors (shown).

# Section 1 — General Information

## 1.1 Certification

UL and CSA approvals have been obtained on the 06T screw compressors with the following refrigerants:

1. R-22
2. R-134a
3. R-404A & R-507

The UL file number is SA4936. CSA file number is LR29937; CSA report number is LR29937-579c.

For UL and CSA approvals it is essential that only listed special purpose circuit breakers or Furnas 958 series solid state overload relays be used. (See Section 5.2 and 5.3 for selection tables). The must trip amp settings should not exceed 140% of the compressor rated load amps.

Both UL and CSA approvals have been obtained for all voltage combinations listed in Section 5.3. 60 Hz compressors have been listed.

## 1.2 Screw Compressor Size (Displacement)

06T compressors are available in the following displacement sizes:

| Model No. | 60 Hz                |                     | 50 Hz                |                     |
|-----------|----------------------|---------------------|----------------------|---------------------|
|           | ft <sup>3</sup> /min | m <sup>3</sup> /min | ft <sup>3</sup> /min | m <sup>3</sup> /min |
| 06T**033  | 33                   | 0.93                | 27.5                 | .78                 |
| 06T**039  | 39                   | 1.10                | 32.5                 | .92                 |
| 06T**044  | 44                   | 1.25                | 36.7                 | 1.04                |
| 06T**048  | 48                   | 1.36                | 40.0                 | 1.13                |
| 06T**054  | 54                   | 1.53                | 45.0                 | 1.28                |
| 06T**065  | 65                   | 1.84                | 54.2                 | 1.53                |
| 06T**078  | 78                   | 2.21                | 65.0                 | 1.84                |
| 06T**088  | 88                   | 2.49                | 73.3                 | 2.08                |
| 06T**108  | N/A                  | N/A                 | 90.0                 | 2.56                |

Semi-hermetic compressors will be supplied with single voltage motors 208/230 volts, 460 volts and 575 volts.

## 1.3 Compressor Mounting

The Carlyle 05T/06T screw compressors may be rigid mounted. However, Carlyle recommends the use of isolation mounts (**Carlyle P/N KA75KR007, Package No. 06TA660007**) for 06T compressors. These rubber mounts isolate the compressor from the system framework which helps to reduce noise transmission.

## 1.4 Oil Type

Carlyle screw compressors are approved for use with the oils in the table below (based on refrigerant application).

Contact Carlyle Application Engineering for alternate POE oil selections.

See section 9.1 for System oil charging recommendations.

| POE Oil Type          | R-404A & R-507 |              | R-134a             | R-22      |              |
|-----------------------|----------------|--------------|--------------------|-----------|--------------|
|                       | Low Temp.      | Medium Temp. | Medium Temp. & A/C | Low Temp. | Medium Temp. |
| Castrol SW100 *       | NO             | YES          | YES                | NO        | YES          |
| CPI Solest BVA 120 *† | YES            | YES          | YES                | YES       | YES          |
| CPI Solest 170 **     | YES            | YES          | YES                | YES**     | YES**        |
| ICI Emkarate RL100S   | YES            | YES          | YES                | YES       | YES          |
| Castrol E100 *        | YES            | YES          | YES                | YES       | YES          |

\* UL Certified

† For application purposes, Solest 120 oil is considered to be the same viscosity as POE 100 oils.

\*\* Required for R-22 systems without external oil Cooler. R-22 systems with external oil cooler may use POE 100 oils.

## 1.5 Ambient Conditions

The screw compressor is designed for the following specified ambient temperature ranges:

|               |                                   |
|---------------|-----------------------------------|
| Non-Operating | -40°F To 130°F<br>(-40°C To 54°C) |
| Start-Up      | -40°F To 130°F<br>(-40°C To 54°C) |
| Operating     | -25°F To 130°F<br>(-32°C To 54°C) |

## 1.6 Installation Environment

The intended installation modes for the screw compressor are:

Machine Rooms—Enclosed Atmosphere  
External Environment—Sheet Metal Enclosure

NOTE: The electrical terminal box is not approved for external applications.

## 1.7 Pressure Relief Valve

All compressor models contain an automatic reset high pressure relief valve. The pressure relief valve is located inside the compressor and will internally vent the compressor discharge to the compressor suction when it relieves. The valve opens at a pressure differential of 400 psi (27.6 bar). The relief valve is not field serviceable.

## 1.8 Discharge Check Valve

All compressor models are supplied with an internal discharge check valve. This check valve prevents the reverse flow of refrigerant through the compressor during compressor off cycles. A check valve in the discharge line is not required for parallel applications. It may be required for pump down on single compressor systems.

The discharge check valve is field serviceable.

## 1.9 Compressor Inlet Screens

Filter screens are applied at all locations where liquid or gas enters the compressor, i.e., suction, economizer and oil connections.

For systems that operate below -25F (-32c), it is recommended that the suction screen be removed after 48 hours of system startup as the viscous oil can damage the screen.

The compressor inlet screens are field serviceable and available through Carlyle distribution.

## 1.10 Service Valves

Suction and discharge connections will interface with the 2-1/2" bolt pattern service valves currently being used on the Carlyle reciprocating compressors. Rotalock® service valves are used for the economizer line shut off. The line sizes are as follows:

| Connection | Connection Size |        |
|------------|-----------------|--------|
|            | Max.            | Min.   |
| Suction    | 1-5/8"          | 1-1/8" |
| Discharge  | 1-5/8"          | 1-1/8" |
| Economizer | 7/8"            | 7/8"   |

All compressor models are supplied with the 1-5/8" suction and discharge service valves and the 7/8" economizer valve.

All 05T compressors and 06T compressors between 65cfm and 88cfm use a barstock service valve, (06TA680008) which is physically larger than the standard service valve (06TA660001) used on all 06T compressors between 33cfm - 54cfm (see compressor physical dimensions on pages 2 & 3).

## 1.11 Condenser Pressure Control

### ***Important!***

**Large variations in head pressure will result in very poor oil separation which may result in nuisance oil level switch tripping. The condenser pressure must be controlled such that fluctuations are gradual. Carlyle screw compressors must be applied with a minimum of one condenser fan (preferably variable speed) active at all times and a means of minimum head pressure control for low ambient operation. For alternate methods of condenser control, please contact Carlyle Application Engineering.**

# Section 2 — Operating Specifications

## 2.1 Operational Envelopes

The following operational envelopes, based on 65°F (18°C) return gas, show the allowable operating suction and discharge pressure ranges for R-134a, R-22, and R-507/R-404A. Operation outside of these envelopes requires

approval from Carlyle Application Engineering or warranty is voided. Oil cooling can be achieved through the use of an oil cooler or with desuperheating valves (as described in Oil Cooling Systems, Section 3.7)

R-22 APPLICATIONS

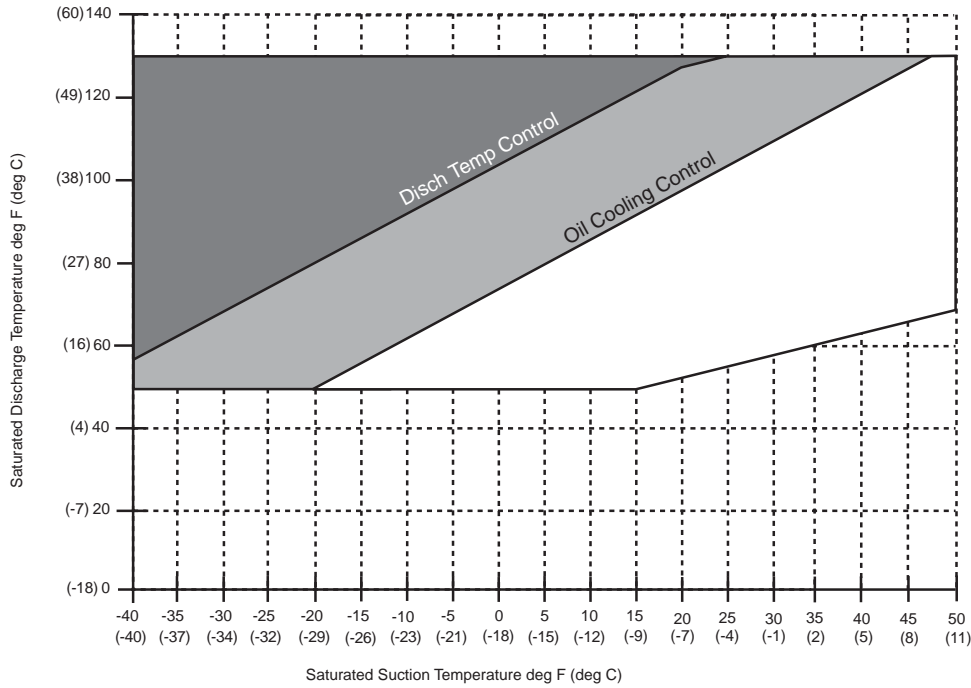

R-134a APPLICATIONS

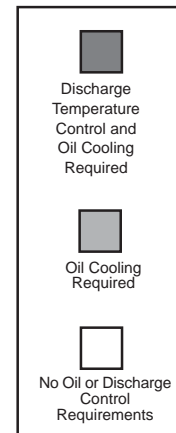
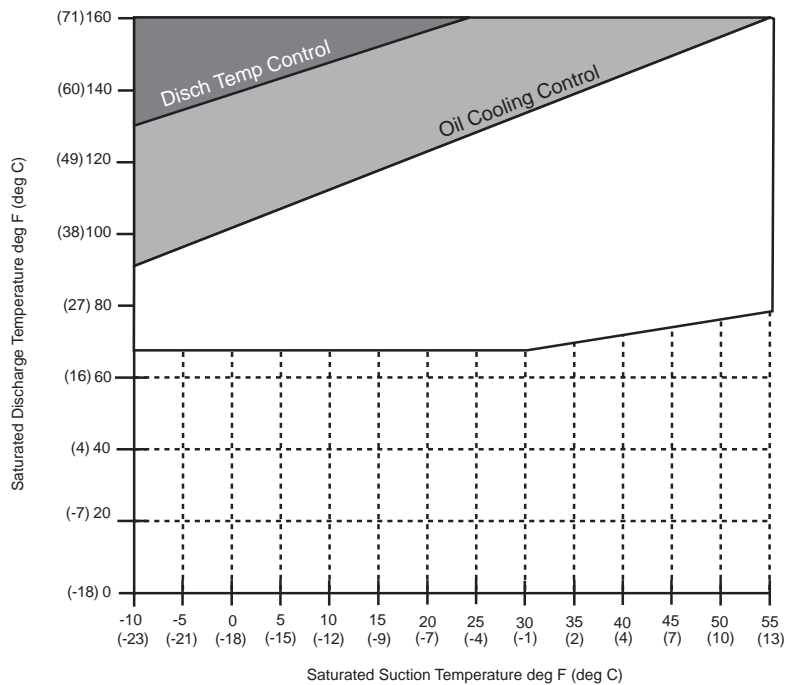



## R-507/R404A APPLICATIONS

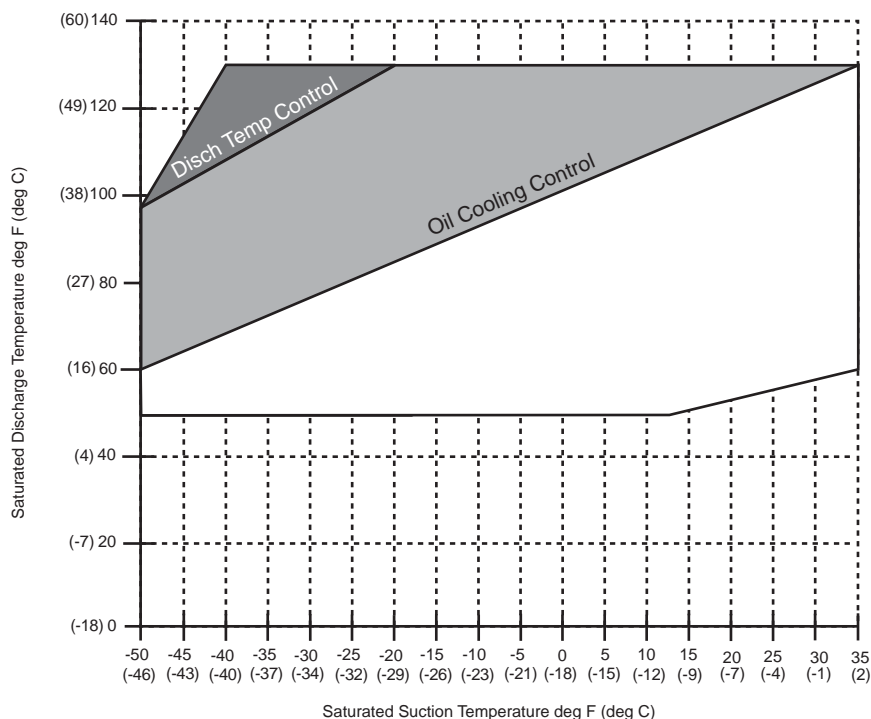

### 2.2 Vapor Temperature Limits

Any application of screw compressors must operate within the limits defined by the application maps for the various refrigerants and applications.

| Vapor Temp. | Min.                 | Max.               |
|-------------|----------------------|--------------------|
| Suction     | 10°F SH*<br>(6°C)    | 100°F<br>(38°C)    |
| Economizer  | Saturated**<br>Vapor | Non-<br>Economized |

\*SH = Superheat

\*\*The maximum economizer pressure allowable is 175.3 psig (13.1 bar)

### 2.3 Minimum Oil Pressure Differential

A minimum pressure differential of 45 psi (3 bar) is required between suction and oil pressure (at the compressor). Applications below this minimum range will require the use of an external oil pump.

### 2.4 Operating Speed Ranges

The operating speed range for the screw compressor is as follows for the different size range compressors.

| Model No. | ft <sup>3</sup> /min | m <sup>3</sup> /min | Min. Hz | Max. Hz |
|-----------|----------------------|---------------------|---------|---------|
| 06T**033  | 33                   | 0.93                | 50      | 70      |
| 06T**039  | 39                   | 1.10                | 40      | 70      |
| 06T**044  | 44                   | 1.26                | 35      | 70      |
| 06T**048  | 48                   | 1.36                | 30      | 70      |
| 06T**054  | 54                   | 1.53                | 30      | 70      |
| 06T**065  | 65                   | 1.84                | 25      | 70      |
| 06T**078  | 78                   | 2.21                | 20      | 68      |
| 06T**088  | 88                   | 2.49                | 20      | 60      |
| 06T**108  | 90*                  | 2.56*               | 20      | 50      |

\* 50 Hz Applications only.

## 2.5 Inverters and Refrigerants

The Carlyle screw compressor is compatible with inverter drives. An inverter drive varies the speed of a compressor to improve system load matching.

### VARIABLE SPEED LIMITS For 06TR Low Temp Compressors

Table 1

| Model No. | Nominal HP | Min. Hz | Max. Hz |
|-----------|------------|---------|---------|
| 06TRC033  | 15         | 50      | 70      |
| 06TRD039  | 20         | 40      | 70      |
| 06TRD044  | 20         | 35      | 70      |
| 06TRE048  | 25         | 30      | 70      |
| 06TRE054  | 25         | 30      | 70      |
| 06TRF065  | 30         | 25      | 70      |
| 06TRG078  | 35         | 20      | 68      |
| 06TRH088  | 40         | 20      | 60      |
| 06TRK108  | 50         | 20      | 50      |

### VARIABLE SPEED LIMITS For 06TA A/C & Med. Temp Compressors

Table 2

| Model No. | Nom. HP | Min. Hz | Max. Hz |
|-----------|---------|---------|---------|
| 06TAD033  | 20      | 50      | 70      |
| 06TAE039  | 25      | 40      | 70      |
| 06TAF044  | 30      | 35      | 70      |
| 06TAF048  | 30      | 30      | 70      |
| 06TAG054  | 35      | 30      | 70      |
| 06TAG065  | 35      | 25      | 70      |
| 06TAH078  | 40      | 20      | 68      |
| 06TAK088  | 50      | 20      | 60      |

Carlyle recommends screw compressors be selected to match the system load at 60 Hz. Overspeeding is a good option during heavy load conditions. Carlyle does not recommend the screw compressor operate at maximum frequency for prolonged periods of time.

Operation above 60 Hz requires adequate motor cooling. Inverters have a tendency to increase the required motor cooling load due to irregular wave forms. When overspeeding, there will be an increased power consumption required to supply the additional capacity. This will also increase the required motor cooling load. It is important that the motor cooling system be capable of handling the increased cooling required for the motor. Oil return, economizer return gas, and the motor cooling valve all assist in cooling the motor. Carlyle recommends applying the largest motor cooling valve (**Carlyle P/N EF28BZ007**) with all screw compressors applied using inverters.

Inverters are an effective tool for efficiently matching system loads with screw compressors. Motor size and motor cooling capabilities must be considered when using an inverter to increase speeds above 60 Hz. Following these guidelines will result in improved system design and performance. An inverter is capable of changing the compressor's speed very quickly from full speed to minimum speed and vice versa. Compressors should ramp-up to the minimum speed within 15 seconds at start-up. After compressor start, Carlyle recommends that the rate of compressor speed change be limited to 600 RPM/Min for the 06T semi-hermetic. **The rate of compressor speed change for the 05T open drive models is required to be no greater than 500 RPM/MIN.**

## 2.6 Compressor Cycling

Although compressor cycling is an effective means of capacity control, frequent starting and stopping shortens the compressor life. Carlyle screw compressors should not be cycled for capacity control more than **six times an hour** and should run for at least 5 minutes after each start.

## 2.7 Mechanical Unloading

All Carlyle screw compressors are equipped with one step of mechanical unloading. The unloader valve is controlled by a solenoid mounted on the compressor body.

**The compressor is unloaded when the solenoid is de-energized and loaded when the solenoid is energized.** The compressor should always be started unloaded (for a minimum time determined by the control module) which will provide a soft start by partially relieving the compression chamber back to suction. Unloaded operation reduces the effective capacity by 30% to 62%, depending on the model and system condition (see tables below).

### ESTIMATED PERCENTAGE UNLOADING BY MODEL

| Models @ 60 Hz | ft <sup>3</sup> /min | m <sup>3</sup> /min | Low Temp. | Med. Temp. |
|----------------|----------------------|---------------------|-----------|------------|
| 06T**033       | 33                   | 0.93                | 60%       | 50%        |
| 06T**039       | 39                   | 1.10                | 59%       | 49%        |
| 06T**044       | 44                   | 1.25                | 58%       | 48%        |
| 06T**048       | 48                   | 1.36                | 56%       | 46%        |
| 06T**054       | 54                   | 1.53                | 55%       | 45%        |
| 06T**065       | 65                   | 1.84                | 50%       | 40%        |
| 06T**078       | 78                   | 2.21                | 45%       | 35%        |
| 06T**088       | 88                   | 2.49                | 40%       | 30%        |

| Models @ 50 Hz | ft <sup>3</sup> /min | m <sup>3</sup> /min | Low Temp. | Med. Temp. |
|----------------|----------------------|---------------------|-----------|------------|
| 06T**033       | 27.5                 | 0.78                | 62%       | 52%        |
| 06T**039       | 32.5                 | 0.92                | 61%       | 51%        |
| 06T**044       | 36.7                 | 1.04                | 60%       | 50%        |
| 06T**048       | 40.0                 | 1.13                | 59%       | 49%        |
| 06T**054       | 45.0                 | 1.28                | 58%       | 48%        |
| 06T**065       | 54.2                 | 1.53                | 55%       | 45%        |
| 06T**078       | 65.0                 | 1.84                | 50%       | 40%        |
| 06T**088       | 73.3                 | 2.08                | 47%       | 37%        |
| 06T**108       | 90.0                 | 2.56                | 46%       | -          |

Unlike reciprocating compressors that should not be run unloaded continuously, the Carlyle screw compressor can be run unloaded continually without affecting the reliability of the compressor. Other methods of reducing the compressor capacity are available and must be approved by Carlyle Application Engineering.

## 2.8 High Discharge Pressure Control

A high pressure cut out must protect the compressor from exceeding 350 psig (25.2 bar). The compressor may be brought back on line after the discharge pressure falls below 300 psig (21.4 bar). The maximum pressure differential (discharge-suction) is 350 psi. The internal pressure relief valve will open if the pressure differential exceeds 400 psi (+/-3%).

## 2.9 Low Suction Pressure Cut Out

A low suction pressure cut out must protect the compressor from operating in a vacuum (below 10" hg). Each compressor must be individually protected with a low pressure switch connected to the low side access port. The compressor may be brought back on line after a 3 minute delay.

## 2.10 Volume Index (Vi) Control

All low temperature models (05TR/06TR) are supplied with a Vi control valve that allows for two Vi settings (see chart below). This dual Vi allows for optimum efficiency over a wide range of head pressures. The Vi must be set to low (solenoid de-energized) during start-up for a minimum of 30 seconds. The Vi may then be set as desired for optimum energy efficiency. The following chart and graph reflect the operational specifications of the Vi control.

The current LonCEM® controller continuously monitors the operating pressure ratio and controls Vi output accordingly. The older CEM requires external controls to accomplish the same task.

| System Pressure Ratio | Vi        | Solenoid |
|-----------------------|-----------|----------|
| Greater Than 5:1      | High: 4.0 | On       |
| Less Than 5:1*        | Low: 2.8  | Off      |

\*Medium/High temperature "TA" compressor models have a fixed Vi of 2.8.

### Vi SETTINGS CHART (PSIG)

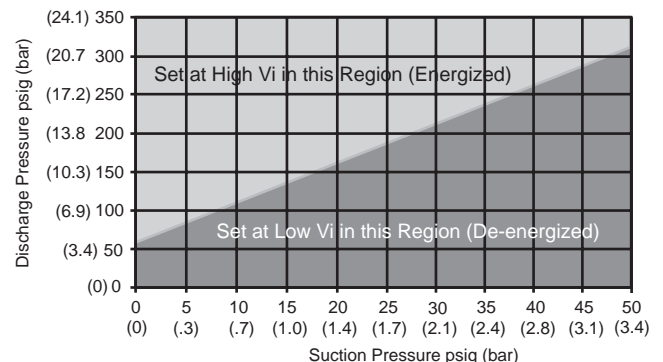

## 2.11 Reverse Rotation Protection

Correct compressor rotation is critical for compressor reliability. The compressor can fail within 2-6 seconds of start-up if it is not rotating in the correct direction. Installation of a pressure gage at the discharge pressure access fitting in the compressor body (measuring the pressure upstream of the integral discharge check valve) is recommended during initial start-up or whenever the compressor is serviced. The gage should be monitored to ensure increasing discharge pressure at start-up.

The new LonCEM protection module (available midyear 2000) uses a pressure sensor to monitor the discharge pressure change at start-up to ensure proper compressor rotation. The LonCEM module eliminates the need for a mechanical low-pressure switch and line/load phase monitor. See Appendix A for descriptions of operation applications for the LonCEM module.

## 2.12 Mufflers

Screw compressors emit very high frequency gas pulsations that have the potential to result in significant discharge line and oil separator noise. The addition of the Carlyle screw compressor muffler is required in all applications to reduce discharge line and oil separator noise levels (**Carlyle P/N LM10HH162**). The muffler should be located within 6-in. of the compressor discharge service valve.

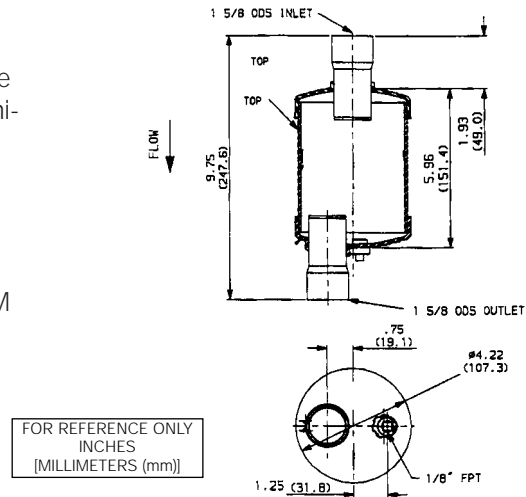

Screw Compressor Muffler

## PHASE MONITOR WIRING DIAGRAM

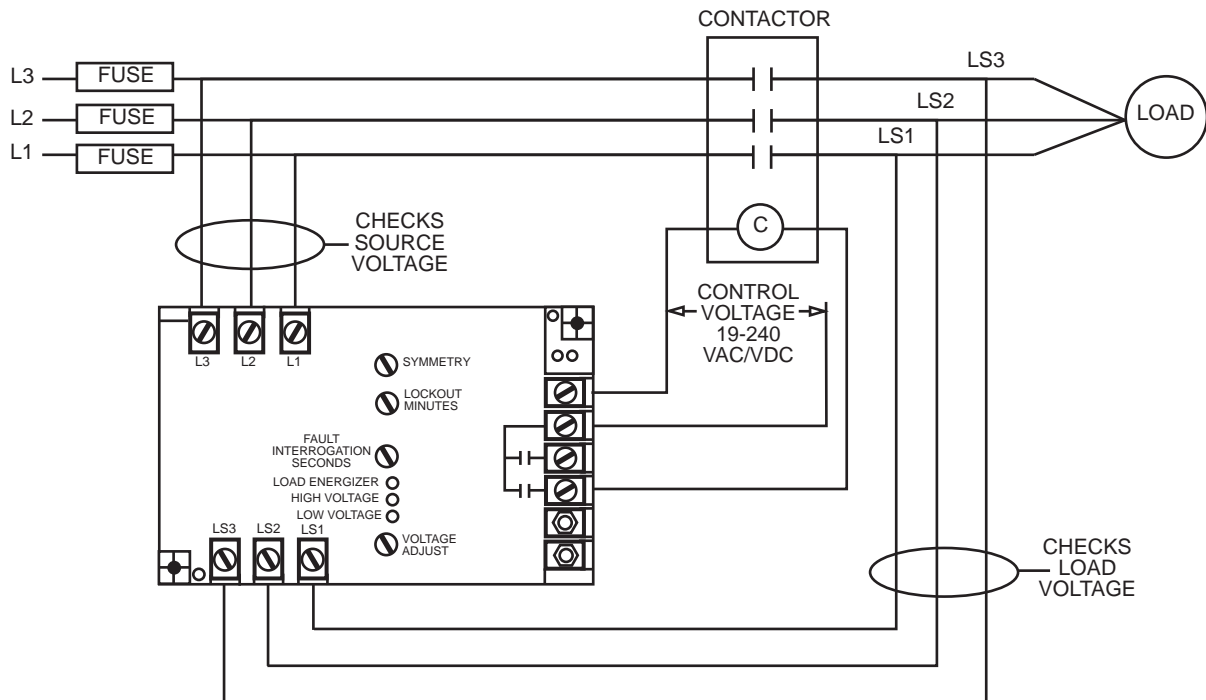

# Section 3 — Oil Management System

## 3.1 Oil Separator

An oil separator is required on all Carlyle screw compressor systems. Carlyle offers two sizes of vertical oil separators. Parallel systems (over two compressors) require the use of the Carlyle 14" (35.6cm) separator, and single and double compressor systems require the use of the Carlyle 12" (30.5cm) separator. See the drawings below for dimensional information on the oil separators.

**12" (30.5cm) VERTICAL OIL SEPARATOR  
PHYSICAL DIMENSIONS**

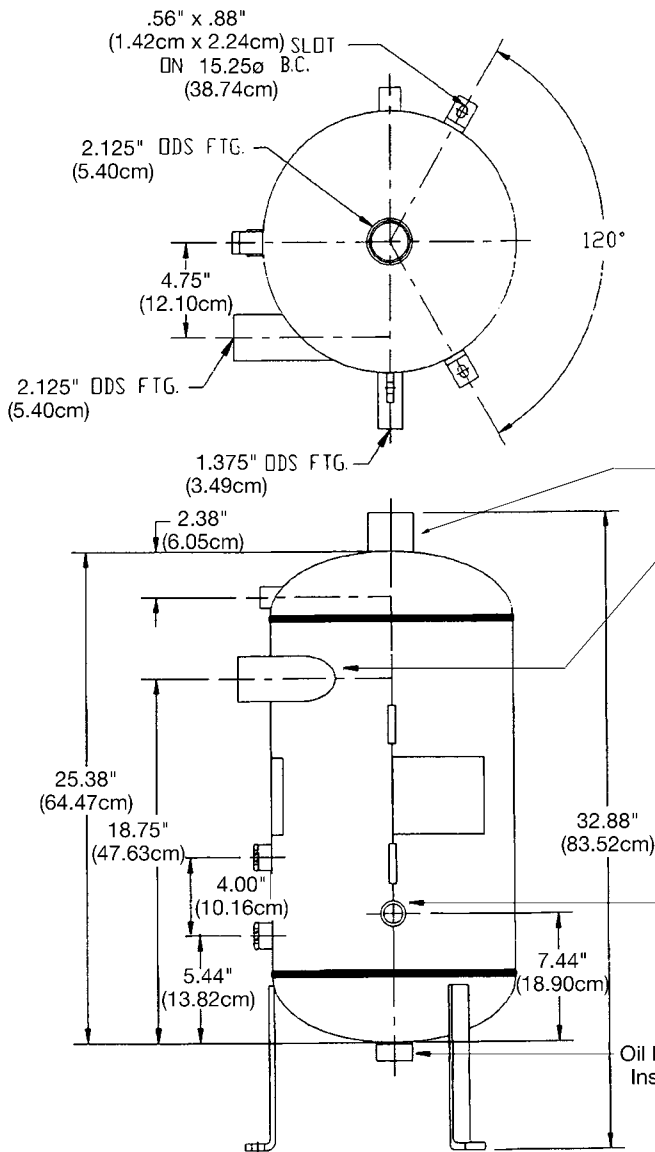

**14" (35.6cm) VERTICAL OIL SEPARATOR  
PHYSICAL DIMENSIONS**

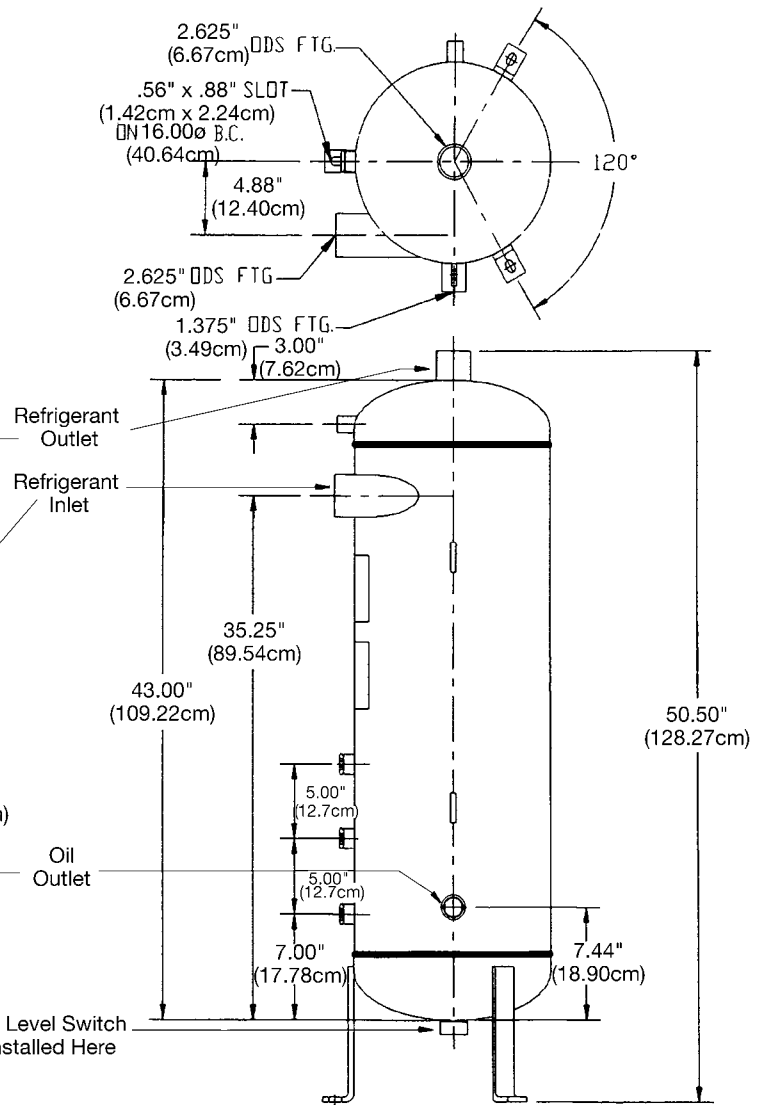

FOR REFERENCE ONLY  
INCHES  
[CENTIMETERS (cm)]

### 3.2 Piping Configuration

The inlet piping from the compressor to the separator should follow a few simple rules:

1. The discharge header should be one consistent size throughout.
2. Step changes in the line diameter should be avoided with the exception of the reducing fittings required to couple to the oil separator.

To optimize the performance of the separator, it should be piped with a 90° elbow in the discharge line just prior to entering the oil separator as shown below.

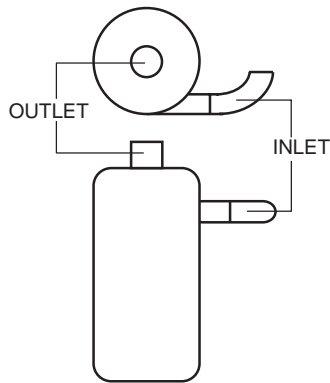

Inlet piping to the separator must be sized to maintain sufficient velocity at the minimum load condition of the rack. The minimum velocity should be no less than 20fps (feet per second) (6.1 mps [meters per second]) and the maximum velocity should be no more than 75fps (22.9 mps). Velocities above this limit may result in excessive pressure drop across the oil separator.

Steel refrigerant piping should not be used on screw compressor applications. See section 4.1 for further details.

### 3.3 System Oil Charge

The system oil charge will vary depending on the size of the separator used, size of the oil cooler (where applicable), oil manifolding, and natural refrigerant piping traps and coating. The nominal oil charge for a three-compressor parallel rack is approximately 10–20 gallons (28.5–57 liters), but may vary significantly.

The oil charge (i.e. quantity required to fill to the top sight glass) for the smaller single compressor oil separator is approximately 5 gallons, while it is 10 gallons for the larger separator.

See section 9.1 for the recommended oil charging procedure.

The screw compressors have no oil sump and therefore are shipped empty and must not be charged. For the recommended oil type, please refer to Section 1.4.

Carlyle recommends operating the system with the oil level between the top two sight glasses on the oil separator.

### 3.4 Oil Level Switch

An oil level switch is required and must be located in the bottom of the oil separator or reservoir. The level switch is used to monitor the oil level and act as a safety in case of low oil levels. **The float switch must be wired to open all the compressor control circuits on the rack during cases of low oil level.** The float switch will be normally closed when adequate oil is in the separator or reservoir sump. **This device is 240v pilot duty and rated for 20 VA maximum.** During transient conditions, the oil level switch may rapidly fluctuate causing nuisance tripping. To avoid this, the level switch may be controlled by the rack controller with the following logic:

DEFINITIONS:

```
OIL_LEVEL          PROGRAM VARIABLE
OIL_LEVEL = 1      OIL LEVEL OK
OIL_LEVEL = 0      OIL LEVEL FAULT
FLOAT PROGRAM COUNTER VARIABLE
LEVEL PROGRAM VARIABLE TO INCREMENT/DECREMENT COUNTER
LEVEL = 1          OIL LEVEL OK
LEVEL = -1         OIL LEVEL FAULT
PROGRAMMING:
INITIALIZATION BLOCK
FLOAT = 3
```

PROGRAM BLOCK

```
READ OIL_LEVEL
LEVEL = 2*(OIL_LEVEL - .5)  -CONVERTS 1 OR 0 TO 1 OR -1
FLOAT = FLOAT + LEVEL
IF (FLOAT = 0) THEN SHUTDOWN COMPRESSOR(S)
IF (FLOAT > 3) THEN (FLOAT = 3)
-LIMIT FLOAT TO MAXIMUM OF 3
REPEAT PROGRAM BLOCK EACH 15 SECONDS
```

This Anti-Cycling algorithm will keep a running tally of the oil level switch status. The algorithm reduces the likelihood of nuisance tripping at low oil level.

Another method to avoid nuisance trips is to add a 30-second time delay to the oil level switch control circuit. (After a trip, a 2-minute time delay may be incorporated before attempting to restart.)

## OIL LEVEL SWITCH DIMENSIONS

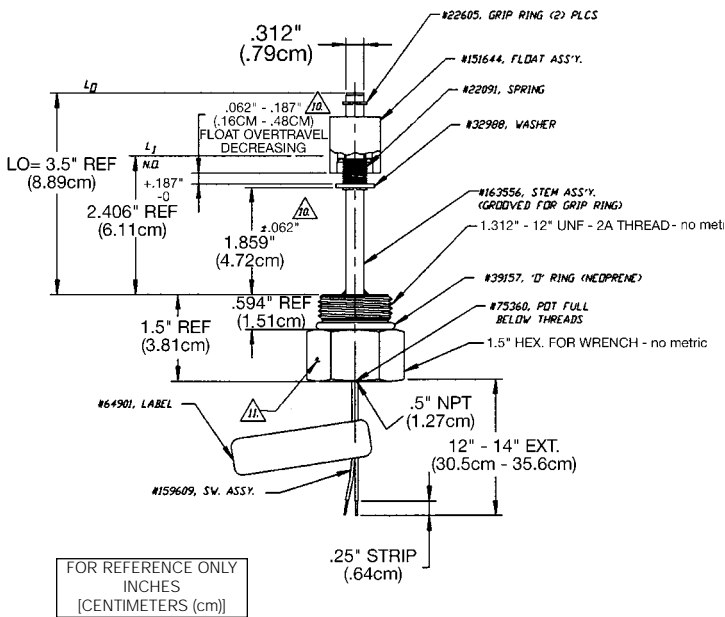

### 3.5 Oil Pressure Protection

Current Carlyle compressor design requires that oil is fed to the compressor at discharge pressure. The pressure differential between oil pressure (discharge pressure-oil pressure drop) and suction pressure is used to drive oil through the compressor. There cannot be any excessive flow restrictions (excessive pressure drop across oil filters, etc...) in the oil system to ensure adequate lubrication. There must be sufficient oil pressure differential between the oil pressure and the suction pressure to drive the lubricant through the compressor.

The LonCEM protection module (available mid-year 2000) provides comprehensive oil pressure protection through the use of discharge pressure, oil pressure and suction pressure transducers to monitor operating pressures. Appendix A contains a complete description of the application and operation of the LonCEM module. Refer to the following table for a summary of LonCEM parameters for alarms (indicate system problems and allow the compressor to continue operating) and cut-outs (causes compressor to shut down and requires manual reset).

| Parameter                 | Explanation   | Alarm/Cut-Out | Reset  |
|---------------------------|---|---------------|--------|
| Oil system Pressure Drop  | Discharge pressure – oil pressure is greater than 35 psi (2.4bar)                   | Alarm         | Auto   |
|                           | Discharge pressure – oil pressure is greater than 50 psi (3.4bar)                   | Cut-Out       | Manual |
| Oil Pressure Differential | Oil pressure – suction pressure is less than 45 psi (3.0bar) for 90 seconds or more | Cut-Out       | Manual |

Refer to Appendix B for information regarding the oil protection system used with the Carlyle Electronic Module (CEM) prior to midyear 2000.

### 3.6 Oil Solenoids

A normally closed solenoid is required in the oil feed line to each compressor, located before (upstream of) the high side of the Oil Pressure Differential Switch (OPDS). **To avoid excessive pressure drop, the internal port size must be 5/16" diameter or larger.** An oil strainer is required before each oil solenoid (or as an integral part of the solenoid). The solenoid will protect the compressor from being filled with oil from the high pressure oil feed line during the off cycle. Each solenoid must be properly wired to the Carlyle CEM (per installation instructions) of the compressor it is controlling. The valve must be open during the on cycle and closed during the off cycle.

**Manually adjustable valves must be checked to ensure the manual operation stem is completely back seated (ensuring the valve is closed when the solenoid is de-energized).** Carlyle does offer a combination oil control solenoid valve and sight glass assembly (EF23ZZ025) which incorporates a solenoid valve.

#### **Warning!**

*When testing the control circuit without the compressor running, the oil line must be valved off so that the compressor will not be filled with oil.*

Whenever possible use control logic to determine that the compressor is actually running before opening the oil solenoid. There are two ways to accomplish this:

1. Make sure the current is greater than zero and less than the locked rotor amperage (LRA).
2. Make sure the discharge plenum pressure is greater than the suction pressure (this method is ineffective on multiple compressor racks).

### 3.7 Oil Cooling Systems

Carlyle 06T semi-hermetic screw compressors can be operated for most applications without external oil cooling. 05T open drive screw compressors require external oil cooling any time the system discharge temperature may exceed 180°F. Carlyle's Carwin selection software can be used to estimate the discharge temperature for a given application.

When an oil cooler is not required, it also eliminates the need for any oil mixing components to keep the oil within a designated temperature range when the oil is being returned from an air cooled oil cooler during low ambient periods.

Operating without an oil cooler does not change the lubricant recommendations for R-404A/507. The recommendation is to use POE 100 or 170 lubricants. For R-22 applications the recommendation for a lubricant is POE 170, CPI Solest 170, for all R-22 low, medium and high temperature applications.

When an oil cooler is used with R-22, the recommendation is to use POE 100 or 170.

**Operating without an oil cooler does impact the system's condenser selections.** Since the oil cooler removes heat from the compressor, additional heat will be transferred to the compressor's heat of rejection, or condenser load. Current versions of Carlyle's compressor selection program take this into consideration, allowing selections to be made with or without an external oil cooler.

Operating without an oil cooler results in little or no performance change on higher displacement models. The slower rotor speeds on smaller CFM models results in a discernable capacity loss that may require consideration. Current versions of Carlyle's compressor selection program take this into consideration, allowing selections to be made with or without an external oil cooler.

| <b>Allowable Application Range Without Oil Coolers</b> |                                  |                                     |                                 |
|--|----------------------------------|-------------------------------------|---------------------------------|
| <b><u>Application:</u></b>                             | <b><u>Saturated Suction:</u></b> | <b><u>Saturated Condensing:</u></b> | <b><u>Recommended Oils:</u></b> |
| R-404A/507 Low Temp.                                   | -40 F to 0 F                     | 70 F to 120 F                       | POE 100 or 170                  |
| R-404A/507 Medium Temp.                                | 0 F to 50 F                      | 70 F to 130 F                       | POE 100 or 170                  |
| R-134a Medium & High Temp.                             | -10 F to 50 F                    | 70 F to 150 F                       | POE 100 or 170                  |
| R-22 Low Temp.   | -25 F to 0 F                     | 70 F to 120 F                       | POE 170*                        |
| R-22 Low Temp.   | -30 F to -26 F                   | 70 F to 110 F                       | POE 170*                        |
| R-22 Medium & High Temp.                               | 0 F to 50 F                      | 70 F to 130 F                       | POE 170*                        |

\* If oil cooler used, oil can revert to POE 100



The oil cooler does offer some help in keeping the discharge and motor temperatures within their respective limits. To make up for this lost cooling some additional refrigerant injection is required. For screw compressors this injection is by the motor cooling valve or at the rotor injection port. Because refrigerant injection for motor and discharge cooling flows into the screw rotor chamber after the suction gas is trapped, compressor capacity is not affected significantly. Under some conditions the motor cooling valve can accommodate this extra cooling requirement. For conditions requiring additional injection, a Sporlan Y-1037 desuperheating valve, or its equivalent, is recommended. It should be selected to start opening at a discharge temperature of 190 F and be fully open at 200 F. The bulb should be located on the discharge line within 6" of the compressor

discharge service valve. A properly sized solenoid valve should be located upstream to insure positive shut-off when the compressor is off.

The tables presented at the bottom of this page present desuperheating size and part number information for those applications where an oil cooler is not used.

Even when an oil cooler is used, desuperheating may still be required. For R-22 systems, the desuperheating valve is required when the saturated suction temperature is below -25°F (-32°C) and for R-404A/R-507 systems, it is necessary when the saturated suction temperature is below -40°F (-32°C). This valve is available through Carlyle (1 ton (3.5Kw); 1.5 ton (5.3Kw); contact Carlyle Application Engineering for valve selection).

## DESUPERHEATING VALVE SIZING WITHOUT OIL COOLER

| Compressor Model          | HP | R-22 Added Desuperheating   |                             | R-404A/507 Added Desuperheating |                             | R134a Added Desuperheating  |                             |
|---------------------------|----|-----------------------------|-----------------------------|---------------------------------|-----------------------------|-----------------------------|-----------------------------|
|                           |    | Low Temp.                   | Med/High Temp.              | Low Temp.                       | Medium Temp.                | Medium Temp.                | High Temp.                  |
| <b>Low Temp.</b>          |    |                             |                             |                                 |                             |                             |                             |
| <b>SCT Range</b>          |    | 70 to 120 F<br>(21 to 49 C) |                             | 90 to 120 F<br>(32 to 49 C)     |                             | 70 to 150 F<br>(21 to 65 C) | 70 to 150 F<br>(21 to 65 C) |
| 06TRC033                  | 15 | FV-2                        | N/A                         | FV-1*                           | N/A                         | None                        | None                        |
| 06TRD039                  | 20 | FV-3                        | N/A                         | FV-1-1/2*                       | N/A                         | None                        | None                        |
| 06TRD044                  | 20 | FV-3                        | N/A                         | FV-1-1/2*                       | N/A                         | None                        | None                        |
| 06TRE048                  | 25 | FV-3                        | N/A                         | FV-2*                           | N/A                         | None                        | None                        |
| 06TRE054                  | 25 | FV-3                        | N/A                         | FV-3*                           | N/A                         | None                        | None                        |
| 06TRF065                  | 30 | FV-5                        | N/A                         | FV-3*                           | N/A                         | None                        | None                        |
| 06TRG078                  | 35 | FV-5                        | N/A                         | FV-3*                           | N/A                         | None                        | None                        |
| 06TRH088                  | 40 | FV-5                        | N/A                         | FV-3*                           | N/A                         | None                        | None                        |
| 06TRK108                  | 50 | FV-5                        | N/A                         | FV-3*                           | N/A                         | None                        | None                        |
| <b>Med Temp/High Temp</b> |    |                             |                             |                                 |                             |                             |                             |
| <b>SCT Range</b>          |    |                             | 70 to 130 F<br>(21 to 54 C) |                                 | 70 to 130 F<br>(21 to 34 C) |                             |                             |
| 06TAD033                  | 20 | N/A                         | FV-2**                      | N/A                             | None                        | None                        | None                        |
| 06TAE039                  | 25 | N/A                         | FV-3**                      | N/A                             | None                        | None                        | None                        |
| 06TAF044                  | 30 | N/A                         | FV-3**                      | N/A                             | None                        | None                        | None                        |
| 06TAF048                  | 30 | N/A                         | FV-3**                      | N/A                             | None                        | None                        | None                        |
| 06TAG054                  | 35 | N/A                         | FV-3**                      | N/A                             | None                        | None                        | None                        |
| 06TAG065                  | 35 | N/A                         | FV-5**                      | N/A                             | None                        | None                        | None                        |
| 06TAH078                  | 40 | N/A                         | FV-5**                      | N/A                             | None                        | None                        | None                        |
| 06TAK088                  | 50 | N/A                         | FV-5**                      | N/A                             | None                        | None                        | None                        |

**LEGEND**

- \* Operation with Evap condensers below -25 F SST may not require any additional desuperheating. Contact Carlyle Application Engineering for limits.
- \*\* Operation with Evap condensers above +10F SST may not require any additional desuperheating. Contact Carlyle Application Engineering for limits.

Note: Valve P/N's shown above are for Sportan Valve Y-1037 series desuperheating valves. A valve with a 190 F temperature setting is required. Alternate desuperheating valve sizing or manufacturers must be approved by Carlyle Application Engineering.

| Sporlan Part No. | Carlyle Part No. | Qty./Pkg. | Weight (Lbs.) | Size      |
|------------------|------------------|-----------|---------------|-----------|
| FV-1             | EA02ZD001        | 1         | 2             | 1 ton     |
| FV-1-1/2         | EA02ZD002        | 1         | 2             | 1-1/2 ton |
| FV-2             | EA02ZD030        | 1         | 2             | 2 ton     |
| FV-3             | EA02ZD050        | 1         | 2             | 3 ton     |
| FV-5             | EA02ZD100        | 1         | 2             | 5 ton     |

### 3.8 Oil Cooler Selection

An oil cooler is required on all Carlyle screw compressor systems not operating in the range indicated in the previous section. This is generally for systems requiring lower suction temperatures or higher discharge temperatures. Also, 05T direct drive compressor systems with discharge temperatures that may exceed 180 F (82 C) always require an oil cooler. The oil cooler must be sized based on an oil flow rate of approximately 2 gallons per minute (7.6 liters/minute) per compressor. (The actual oil flow rate will vary based on pressure ratio of the application. The precise oil cooler load may be obtained from the Carlyle compressor selection software.) The maximum oil temperature leaving the oil cooler is 170 F (77 C) and the maximum temperature entering the oil cooler is 200 F (93 C) (based on discharge temperature control). The oil cooler load is nominally 1 ton (3.5 kilowatts) per compressor, but may be calculated with the above data and oil manufacturer's specifications. In applications which require oil cooling some means of controlling the oil temperature entering the compressor is required.

Several possible methods are;

- Oil cooler fan cycling based on oil outlet temperature (10FΔT)
- Oil cooler bypass via a solenoid valve controlled off of oil cooler entering temperature
- Use of a mixing valve to maintain a constant oil temperature entering the compressor
- Some combination of the three methods listed above

The oil may be cooled by means of an air cooled, refrigerant cooled, or water cooled oil cooler. Carlyle offers 4 sizes of air cooled oil coolers for

use with the 05T and 06T screw compressor. Following is selection criteria for the various models along with dimensional information.

If using a refrigerant cooled oil cooler, the oil cooling load will need to be subtracted from either the compressor's evaporator capacity or the subcooling capacity. Using compressor suction pressure will lead to a reduction in system capacity since some of the compressor suction mass flow will now come from the oil cooler. Using the compressor interstage port for oil cooling will not reduce the compressor suction pumping capacity but will indirectly reduce system capacity by decreasing the compressor's ability to do liquid subcooling. The additional mass flow from the oil cooler to the interstage will increase the interstage pressure. This will prevent the subcooler from achieving the lowest possible liquid temperature. Both systems require hold back valves to prevent the oil temperature from dropping below 80 F (27 C).

Also, caution must be taken to ensure that the return gas to the compressor is not too hot. For more information, contact Carlyle Application Engineering.

The oil cooler represents a heat source that may be used for heat reclaim processes such as hot water preheat. Since the oil cooler rejects discharge heat, the heat rejection from the oil cooler can be subtracted from the heat rejection required by the system condenser. This may lead to a smaller size condenser. Condenser circuiting may also be used for oil cooling; however, pressure drops must be taken into account for minimum oil pressure differential to the compressors. A mixing valve is recommended for all oil coolers circuited through a remote air-cooled condenser.

| Oil Cooler Models Available    | Oil Cooling Capacity @ Ambient Air Temperature |                              |                              |                              |
|--------------------------------|--|------------------------------|------------------------------|------------------------------|
|                                | 95°F (35°C)                                    | 100°F (38°C)                 | 105°F (41°C)                 | 110°F (43°C)                 |
| <b>Fan Speed 60Hz</b>          |  |                              |                              |                              |
| KH51ZZ181 (2 Compressors Max)* | 32,100 Btu/Hr (9,405 W/Hr)                     | 30,600 Btu/Hr (8,966 W/Hr)   | 29,000 Btu/Hr (8,497 W/Hr)   | 27,600 Btu/Hr (8,087 W/Hr)   |
| KH51ZZ182 (3 Compressors Max)* | 69,100 Btu/Hr (20,246 W/H)                     | 65,700 Btu/Hr (19,250 W/Hr)  | 62,400 Btu/Hr (18,283 W/Hr)  | 59,100 Btu/Hr (17,316 W/Hr)  |
| KH51ZZ183 (4 Compressors Max)* | 102,600 Btu/Hr (30,061 W/Hr)                   | 97,700 Btu/Hr (28,626 W/Hr)  | 92,800 Btu/Hr (27,190 W/Hr)  | 87,900 Btu/Hr (25,755 W/Hr)  |
| KH51ZZ184 (5 Compressors Max)* | 134,100 Btu/Hr (39,291 W/Hr)                   | 127,700 Btu/Hr (37,416 W/Hr) | 121,300 Btu/Hr (35,541 W/Hr) | 114,900 Btu/Hr (33,665 W/Hr) |

| Oil Cooler Models Available    | Oil Cooling Capacity @ Ambient Air Temperature |                              |                              |                              |
|--------------------------------|--|------------------------------|------------------------------|------------------------------|
|                                | 95°F (35°C)                                    | 100°F (38°C)                 | 105°F (41°C)                 | 110°F (43°C)                 |
| <b>Fan Speed 50Hz</b>          |  |                              |                              |                              |
| KH51ZZ181 (2 Compressors Max)* | 32,200 Btu/Hr (9,405 W/Hr)                     | 28,800 Btu/Hr (8,435 W/Hr)   | 27,300 Btu/Hr (8,438 W/Hr)   | 25,900 Btu/Hr (7,999 W/Hr)   |
| KH51ZZ182 (3 Compressors Max)* | 63,700 Btu/Hr (18,664 W/H)                     | 60,600 Btu/Hr (17,756 W/Hr)  | 57,600 Btu/Hr (16,877 W/Hr)  | 54,600 Btu/Hr (15,998 W/Hr)  |
| KH51ZZ183 (4 Compressors Max)* | 94,900 Btu/Hr (27,805 W/Hr)                    | 90,400 Btu/Hr (26,487 W/Hr)  | 85,900 Btu/Hr (25,168 W/Hr)  | 81,400 Btu/Hr (23,850 W/Hr)  |
| KH51ZZ184 (5 Compressors Max)* | 123,400 Btu/Hr (26,156 W/Hr)                   | 117,500 Btu/Hr (34,427 W/Hr) | 111,600 Btu/Hr (32,699 W/Hr) | 105,800 Btu/Hr (30,999 W/Hr) |

\*Maximum Number of Compressors Based on Oil Cooler Pressure Drop of Less Than 6 PSID (.41 bar)

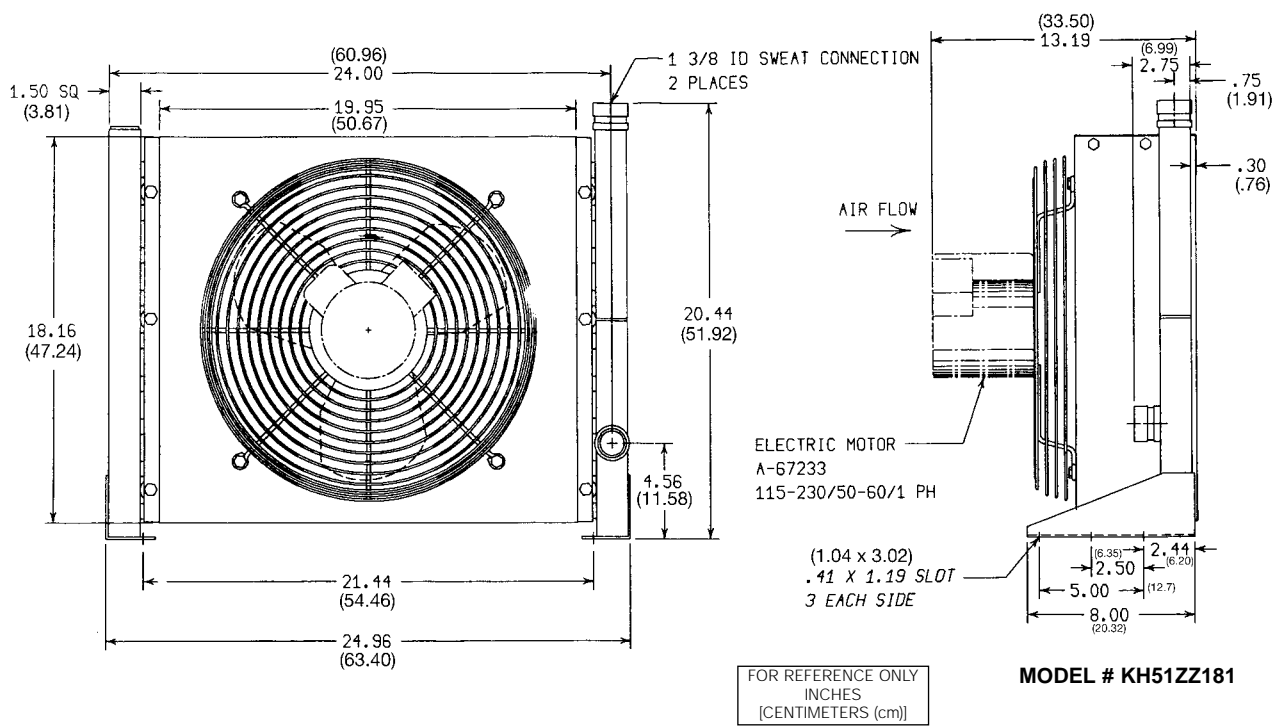

**MODEL # KH51ZZ181**

OIL INLET AT BOTTOM – OIL OUTLET AT TOP; ALL MODELS

Electrical Specifications: All Models  
 Voltage: 115/230V 50/60Hz  
 Amperage\*: 3.2/1.6 Amps Full Load 60Hz  
 2.8/1.4 Amps Full Load 50Hz  
 \*Amperage ratings are per motor

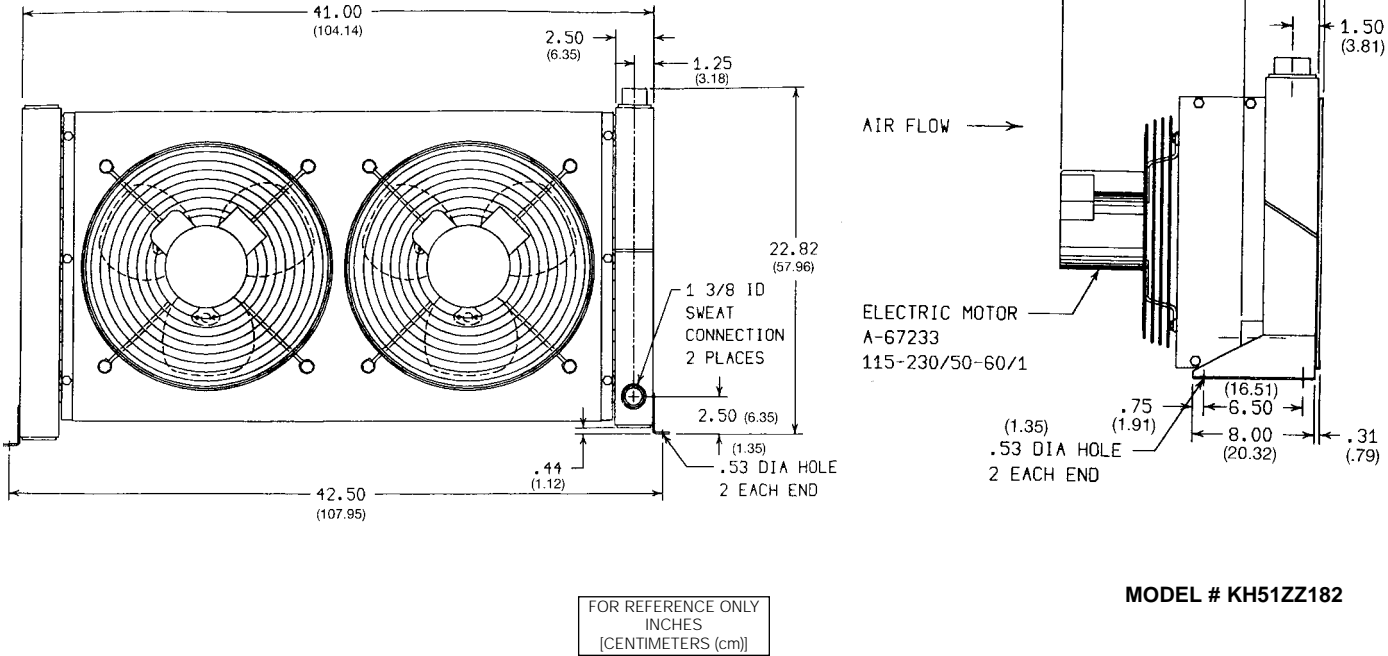

**MODEL # KH51ZZ182**

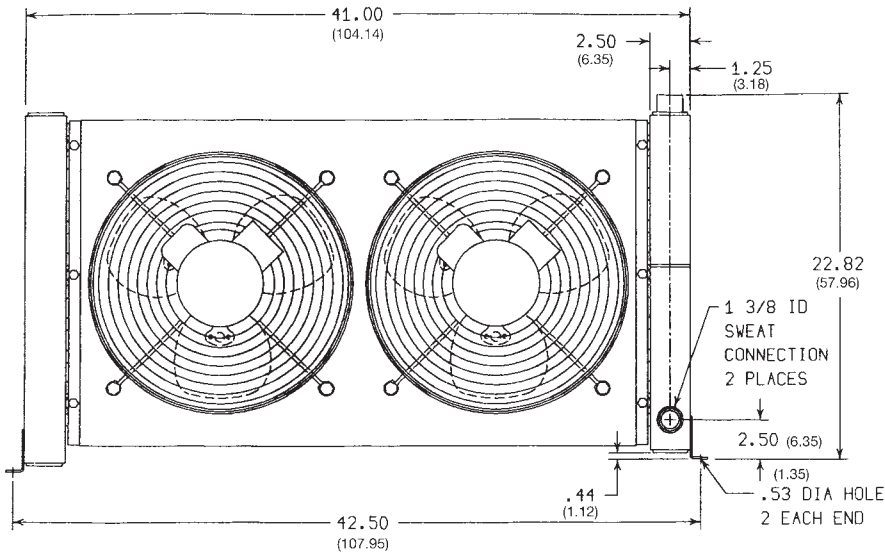

FOR REFERENCE ONLY  
INCHES  
[CENTIMETERS (cm)]

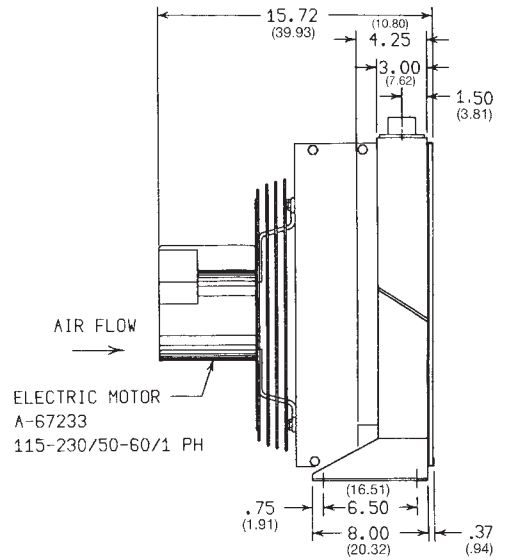

**MODEL # KH51ZZ183**

OIL INLET AT BOTTOM – OIL OUTLET AT TOP; ALL MODELS

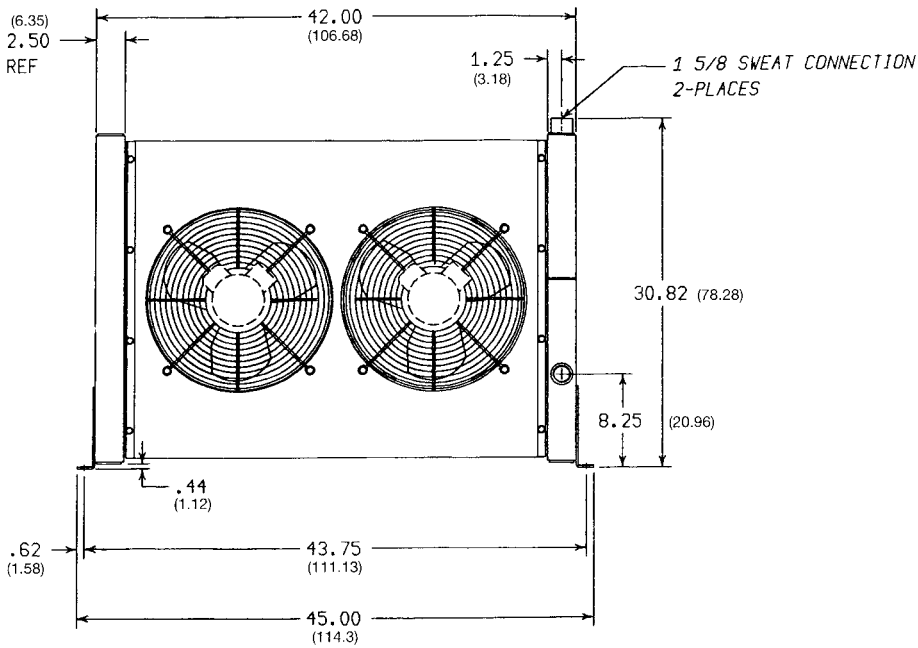

FOR REFERENCE ONLY  
INCHES  
[CENTIMETERS (cm)]

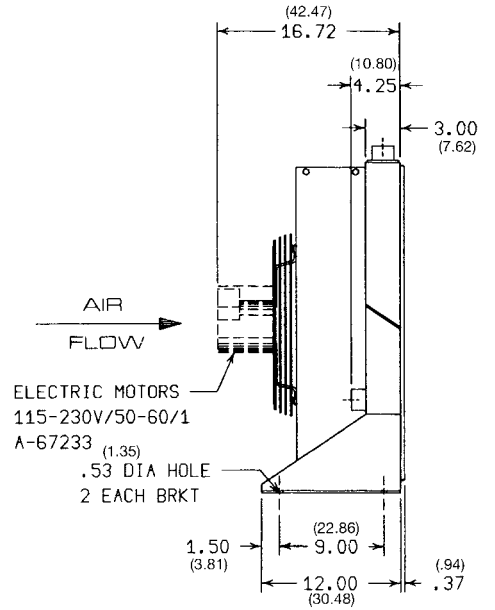

**MODEL # KH51ZZ184**

## OIL CARTRIDGE FILTER ELEMENT

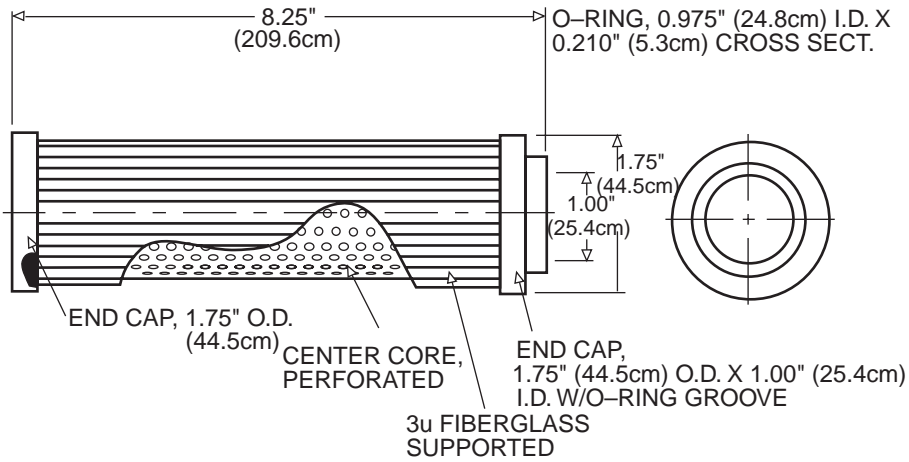

## FILTER HOUSING REPLACEMENT TYPE

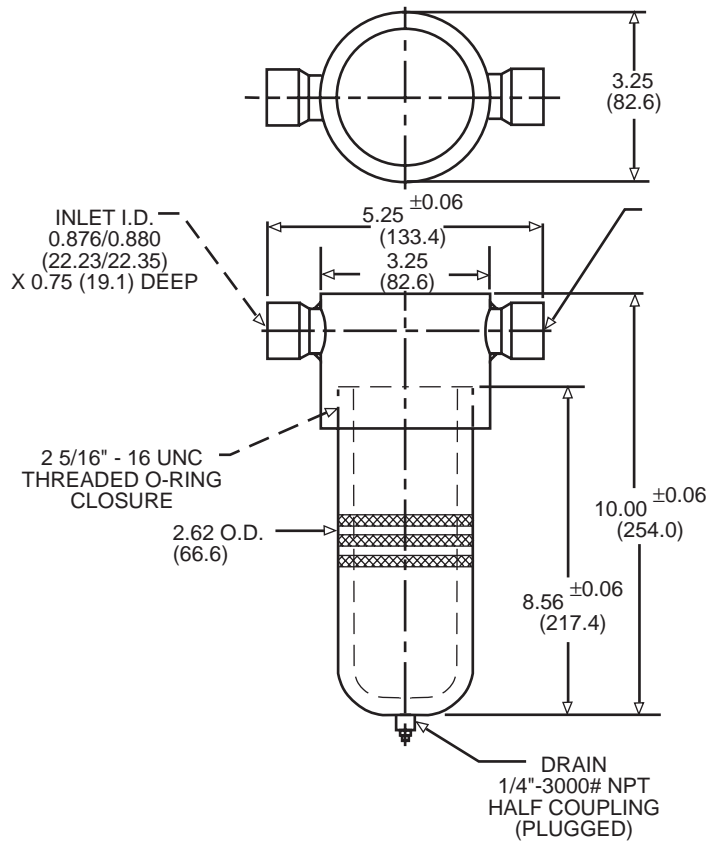

### 3.9 Oil Filter

Carlyle screw compressors are designed with rolling element bearings to provide exceptional life. Oil to the bearings must pass through a 3 micron filter which is required on all Carlyle screw compressor systems. The use of filters in parallel as shown in Section 3.12 (Oil System Schematics) is recommended (one filter per compressor may also be used). One filter (both filters may be used simultaneously) is used at a time and the pressure drop across the filter is monitored. This design allows easy maintenance of the filter element without shutting the system down. The second filter is simply valved on while the first filter is changed.

In general, two oil filter housings are piped in parallel with isolation valves located on either side of the housings as shown in the schematic in section 3.12. If more than 5 compressors are fed by the oil system, 3 oil filter elements should be piped in parallel to avoid excessive pressure drop through the filter elements.

The LonCEM Module is currently used for compressor protection for 05T/06T compressors. It monitors the difference in pressure in the oil system from compressor discharge to the compressor oil inlet with transducers. This includes the pressure drop across the oil filters. See appendix A for settings.

In older systems incorporating the Carlyle Electronic Module (CEM) for compressor protection pressure transducers or a mechanical differential switch can be used to monitor the pressure drop across the oil filters. The setting for filter alarm or replacement can be at the customer's discretion with a maximum value of 25 psi (1.7 bar).

**Note: Use of the Carlyle 3 micron filter element is required. Use of a non-Carlyle-approved filter element will void compressor warranty.**

The oil filter(s) must be located after the oil cooler and as close to the compressor(s) as possible. The oil filter housing is designed for 450 psig (31 bar) maximum working pressure and has UL and CSA code approval for use in HVACR systems. Each new oil filter housing contains one filter element. **Additional filter elements should be ordered and supplied with each compressor system. Six additional elements per rack are recommended.**

### 3.10 Oil Sump Heaters

A 500 watt, 120/240 volt silicon rubber flexible heater is recommended for use on the oil sump of the 12" (30.5cm) oil separator. Two of the above 500 watt heaters (connected together) are recommended for use with the 14" (35.6cm) separator. The heater must be energized during the system off cycle if used. This is required in all air conditioning systems and is recommended in refrigeration systems to keep refrigerant out of the oil sump during compressor off cycles.

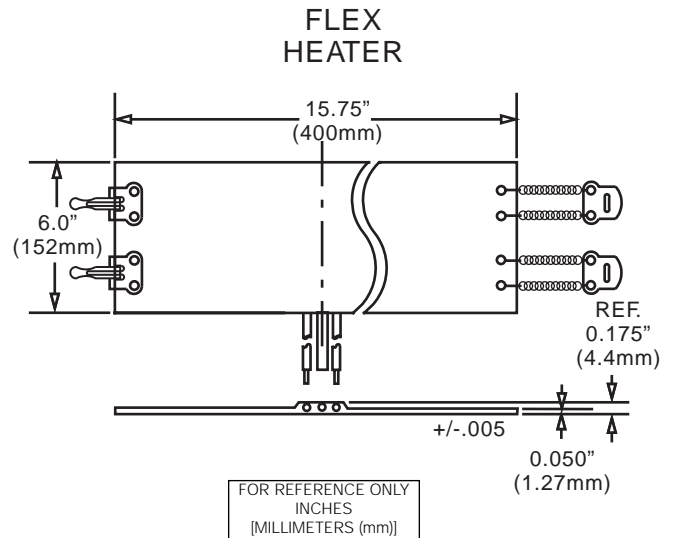

#### FLEX HEATER WIRING DIAGRAM (TO BE LABELED ON PART)

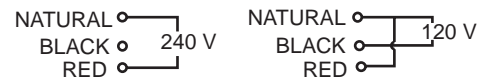

### 3.11 Oil Sight Glass

A sight glass is required in the main oil line. The sight glass must be located after the oil filters and just prior to the first compressor on a multiple compressor rack. (See Oil System Schematics, Section 3.12.) Carlyle recommends a sight glass be placed in each branch oil line between the compressor and its oil solenoids. The sight glass offers a useful feature to help field personnel verify oil is flowing when required and not leaking through when the compressor is off.

Carlyle offers a combination oil solenoid/sight glass that can be used for the application (P/N EF23ZZ025). It mounts directly to the oil inlet of the compressor. Refer to Figure 2, Appendix A for details.

### 3.12 Oil System Schematics

**OIL SYSTEM SCHEMATIC  
ISOMETRIC VIEW**

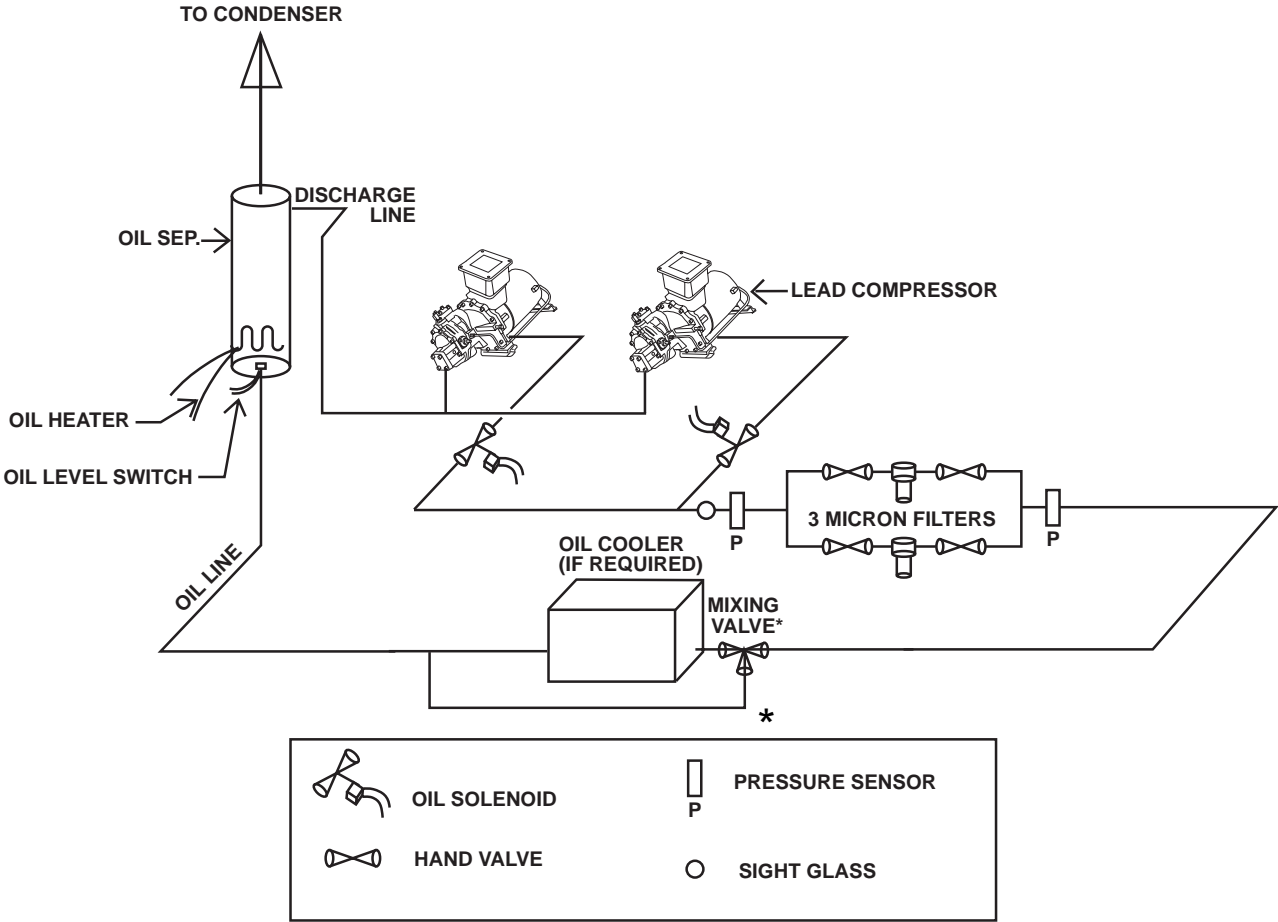

\* Note: Other oil temperature control options are available. See section 3.8.

### 3.13 Oil Line Manifold Selection Table

#### OIL MANIFOLD SIZING FOR PRESSURE DROP

##### 10 Ft Manifold Length

| Number of Compressors | Assumed |      | Manifold O.D. (in.) | Delta P (PSI) |           |            |            |
|-----------------------|---------|------|---------------------|---------------|-----------|------------|------------|
|                       | GPM     | LPM  |                     | at 10 cSt     | at 45 cSt | at 100 cSt | at 170 cSt |
| 1                     | 2       | 7.6  | 7/8                 | 0.17          | 0.77      | 1.72       | 2.92       |
| 2                     | 4       | 15.2 | 7/8                 | 0.34          | 1.54      | 3.43       | 5.83       |
| 3                     | 6       | 22.8 | 7/8                 | 0.52          | 2.31      | 5.15       | 8.76*      |
| 4                     | 8       | 30.4 | 1-1/8               | 0.22          | 0.97      | 2.16       | 3.67       |
| 5                     | 10      | 38   | 1-1/8               | 0.27          | 1.21      | 2.69       | 4.58       |

##### 20 Ft Manifold Length

| Number of Compressors | Assumed |      | Manifold O.D. (in.) | Delta P (PSI) |           |            |            |
|-----------------------|---------|------|---------------------|---------------|-----------|------------|------------|
|                       | GPM     | LPM  |                     | at 10 cSt     | at 45 cSt | at 100 cSt | at 170 cSt |
| 1                     | 2       | 7.6  | 7/8                 | 0.34          | 1.54      | 3.43       | 5.84       |
| 2                     | 4       | 15.2 | 1-1/8               | 0.22          | 0.97      | 2.16       | 3.67*      |
| 3                     | 6       | 22.8 | 1-1/8               | 0.32          | 1.46      | 3.24       | 5.50       |
| 4                     | 8       | 30.4 | 1-1/8               | 0.43          | 1.94      | 4.31       | 7.33       |
| 5                     | 10      | 38   | 1-1/8               | 0.54          | 2.43      | 5.39       | 9.17*      |

##### 30 Ft Manifold Length

| Number of Compressors | Assumed |      | Manifold O.D. (in.) | Delta P (PSI) |           |            |            |
|-----------------------|---------|------|---------------------|---------------|-----------|------------|------------|
|                       | GPM     | LPM  |                     | at 10 cSt     | at 45 cSt | at 100 cSt | at 170 cSt |
| 1                     | 2       | 7.6  | 1-1/8               | 0.15          | 0.70      | 1.62       | 2.75*      |
| 2                     | 4       | 15.2 | 1-1/8               | 0.32          | 1.45      | 3.24       | 5.50       |
| 3                     | 6       | 22.8 | 1-1/8               | 0.49          | 2.18      | 4.85       | 8.25*      |
| 4                     | 8       | 30.4 | 1-1/8               | 0.65          | 2.91      | 6.47       | 11.00*     |
| 5                     | 10      | 38   | 1-3/8               | 0.33          | 1.49      | 3.30       | 5.61       |

##### 40 Ft Manifold Length

| Number of Compressors | Assumed |      | Manifold O.D. (in.) | Delta P (PSI) |           |            |            |
|-----------------------|---------|------|---------------------|---------------|-----------|------------|------------|
|                       | GPM     | LPM  |                     | at 10 cSt     | at 45 cSt | at 100 cSt | at 170 cSt |
| 1                     | 2       | 7.6  | 1-1/8               | 0.25          | 0.91      | 2.42       | 3.67*      |
| 2                     | 4       | 15.2 | 1-1/8               | 0.43          | 1.94      | 4.32       | 7.34*      |
| 3                     | 6       | 22.8 | 1-1/8               | 0.65          | 2.91      | 6.47       | 11.00*     |
| 4                     | 8       | 30.4 | 1-1/8               | 0.35          | 1.50      | 3.52       | 5.99       |
| 5                     | 10      | 38   | 1-3/8               | 0.44          | 1.98      | 4.40       | 7.48*      |

#### LEGEND

LPM - Litres per minute

cSt - Centistrokes

\* If 170 POE oil is used, Carlyle recommends use of the next larger size copper line if pressure drop is greater than 5.0 psi. This will typically reduce pressure drop to 30% of value shown.

#### NOTES:

1. Viscosity of 10 cSt is based on 130 F (54 C) oil with 10% refrigerant dilution.
2. Viscosity of 45 cSt is based on 130 F (54 C) oil, no refrigerant dilution or 80 F (27 C) oil with 10% refrigerant dilution.
3. Viscosity of 100 cSt is based on 100 F (38 C) oil, no refrigerant dilution.
4. Viscosity of 170 cSt is based on 100 F (38 C) oil, with no refrigerant dilution.



# Section 4 — Refrigerant Management System

## 4.1 Suction and Interstage Piping

The suction and interstage manifold should be piped in such a way that liquid cannot gravity drain into any compressor. Carlyle recommends that the manifold be located below the compressor body. An inverted trap must be used coming off the top of the suction header if it is above the compressor body. Common interstage manifolds used in rack applications must be center fed by the economizer. End feeding the interstage manifold results in poor

liquid distribution to the compressors if flooding occurs. Please see the refrigerant piping schematic below.

Steel refrigerant piping is not recommended with screw compressor applications. The contaminant's associated with the steel pipe will overload the 3 micron filters used on the oil system causing excessive and costly filter changes and increasing the chances of oil related compressor failures.

**SYSTEM WITHOUT LIQUID INJECTION INTO ROTORS  
(TYPICAL FOR USE WITH OIL COOLERS)**

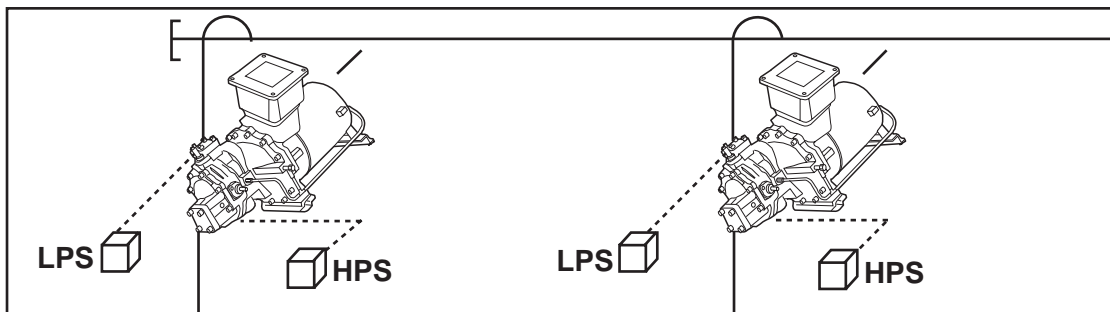
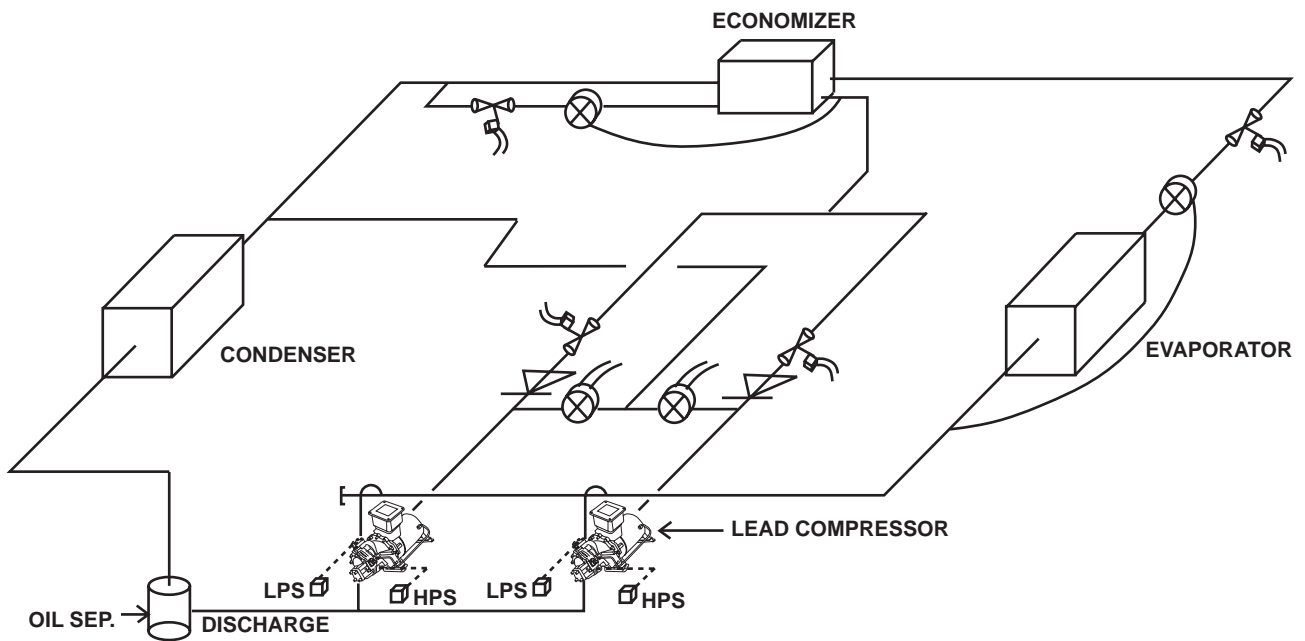

|     |                      |  |                 |
|-----|----------------------|--|-----------------|
| HPS | HIGH PRESSURE SWITCH |  | EXPANSION VALVE |
| LPS | LOW PRESSURE SWITCH  |  | SOLENOID        |
|     | MOTOR COOLING VALVE  |  | CHECK VALVE     |

**ISOMETRIC VIEW (LIQUID INJECTION TO ROTORS)  
TYPICAL, WITHOUT OIL COOLER)**

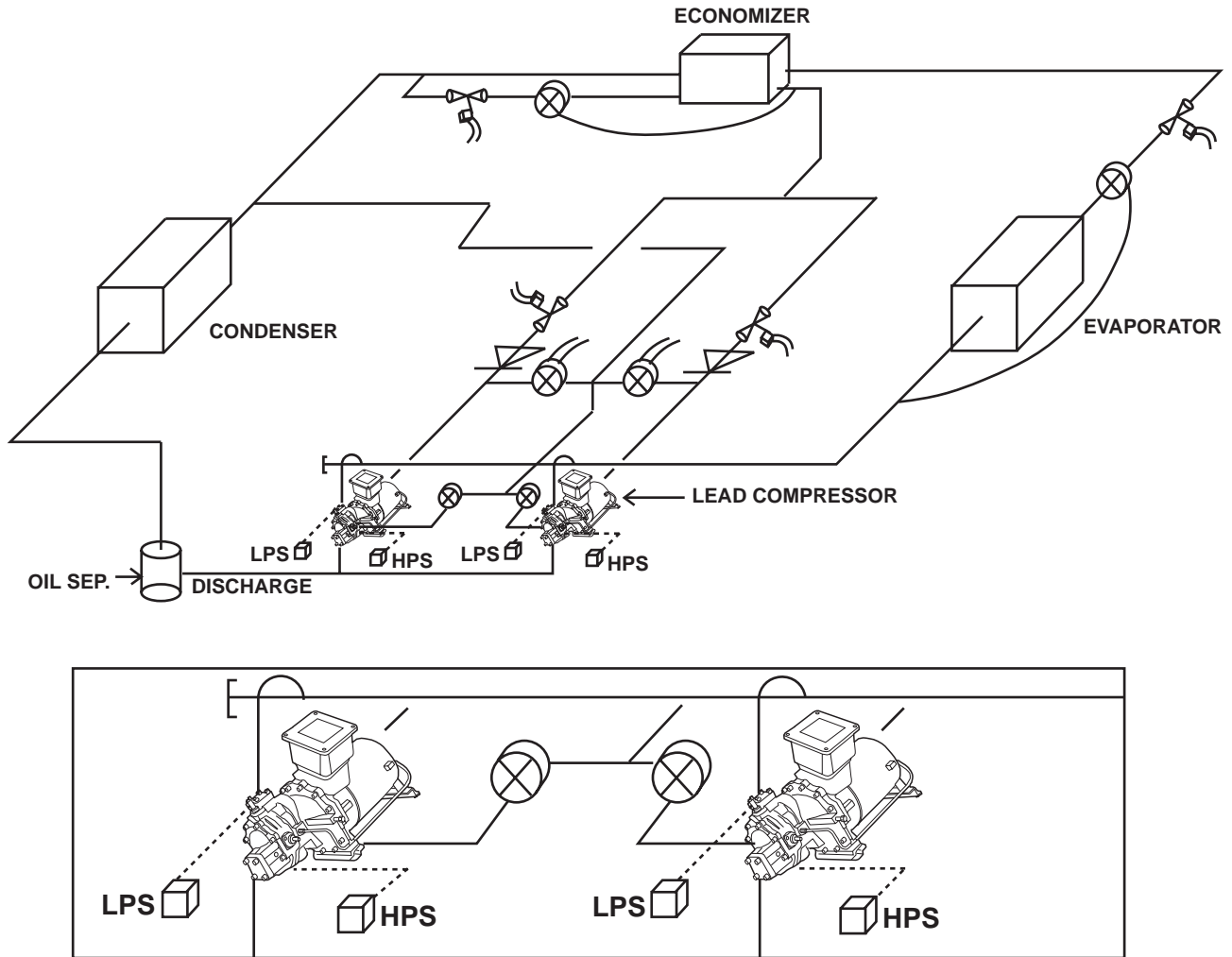

A normally closed solenoid valve is required in the interstage line feeding each compressor on a parallel rack as shown in the refrigerant piping schematic. This valve is required to eliminate interstage to suction pressure leak back during the off cycle of any compressor. When any compressor on the rack turns off, its respective interstage solenoid valve must close and when it turns on its respective interstage solenoid valve must open. The solenoid valve must be properly wired to the Carlyle module (per installation instructions) of the compressor it is controlling.

Check valves are also required in the interstage line feeding each compressor on a parallel rack as shown. The check valve must be located upstream of the motor cooling valve for each

compressor and downstream of the solenoid valve. The check valves are used to eliminate the possibility of reverse flow from any compressor economizer port.

Carlyle also recommends that separate subcoolers be used for each different saturated suction temperature group. Compressors operating with different saturated suction temperatures will have a significant difference in interstage pressure. The resulting amount of subcooling will be lower than stated in the rating tables and overall rack capacity will reduce. Individual subcoolers will also result in more stable subcooler control as compressors cycle (which would significantly vary the interstage pressure, causing the subcooler expansion valve to hunt).

## Section 5 — Electrical Specifications

### 5.1 Thermal Protection

The compressor motor windings are protected from extreme temperatures by the LonCEM Module and the Carlyle Electronic Module (CEM) in older systems. All compressors are supplied with two 5K NTC (Negative Thermal Coefficient) thermistors in the motor windings. The module will limit the maximum motor temperature to 240 F (116 C) and is an auto-reset device. Only one 5K sensor is used; the other is a spare. The temperature vs. resistance characteristics of the 5K thermistors are shown below. Additionally, the DC voltage across the thermistors

may be measured at the module while the compressor is running and compared to the Temperature vs. DC voltage table. **(WARNING: DO NOT MEASURE THE DC VOLTAGE INSIDE THE TERMINAL BOX.)**

Note that while the resistance of the sensors does not change, the measured DC voltage will be different depending on which protection module is used.

See the "Motor and Discharge Thermistors" table in Appendix A for the conversion when using the newer LonCEM module, and the "Temperature VS. DC Voltage" table in Appendix B for older applications with the CEM module.

### TEMPERATURE vs. RESISTANCE TABLE

| TEMPERATURE |      | RESISTANCE |
|-------------|------|------------|
| C           | F    | OHMS       |
| 0           | 32   | 16352.4    |
| 1           | 33.8 | 15515.2    |
| 2           | 35.6 | 14750      |
| 3           | 37.4 | 14027.1    |
| 4           | 39.2 | 13343.8    |
| 5           | 41   | 12697.8    |
| 6           | 42.8 | 12086.3    |
| 7           | 44.6 | 11508      |
| 8           | 46.4 | 10960.8    |
| 9           | 48.2 | 10442.6    |
| 10          | 50   | 9951.8     |
| 11          | 51.8 | 9486.8     |
| 12          | 53.6 | 9046.3     |
| 13          | 55.4 | 8628.7     |
| 14          | 57.2 | 8232.5     |
| 15          | 59   | 7857       |
| 16          | 60.8 | 7500.6     |
| 17          | 62.6 | 7162.3     |
| 18          | 64.4 | 6841.3     |
| 19          | 66.2 | 6526.4     |
| 20          | 68   | 6246.8     |
| 21          | 69.8 | 5971.6     |
| 22          | 71.6 | 5710       |
| 23          | 73.4 | 5461.3     |
| 24          | 75.2 | 5225       |
| 25          | 77   | 5000       |
| 26          | 78.8 | 4786       |
| 27          | 80.6 | 4582.4     |
| 28          | 82.4 | 4388.5     |
| 29          | 84.2 | 4203.9     |
| 30          | 86   | 4028       |
| 31          | 87.8 | 3860.5     |
| 32          | 89.6 | 3700.8     |
| 33          | 91.4 | 3548.5     |
| 34          | 93.2 | 3403.5     |
| 35          | 95   | 3265.1     |
| 36          | 96.8 | 3133.1     |
| 37          | 98.6 | 3007.1     |

| TEMPERATURE |       | RESISTANCE |
|-------------|-------|------------|
| C           | F     | OHMS       |
| 38          | 100.4 | 2886.9     |
| 39          | 102.2 | 2772.1     |
| 40          | 104   | 2662.4     |
| 41          | 105.8 | 2557.8     |
| 42          | 107.6 | 2457.7     |
| 43          | 109.4 | 2362.1     |
| 44          | 111.2 | 2270.8     |
| 45          | 113   | 2183.45    |
| 46          | 114.8 | 2099.93    |
| 47          | 116.5 | 2020.04    |
| 48          | 118.4 | 1943.6     |
| 49          | 120.2 | 1870.5     |
| 50          | 122   | 1800.49    |
| 51          | 123.8 | 1733.46    |
| 52          | 125.6 | 1669.66    |
| 53          | 127.4 | 1607.81    |
| 54          | 129.2 | 1548.95    |
| 55          | 131   | 1492.54    |
| 56          | 132.8 | 1438.46    |
| 57          | 134.6 | 1386.62    |
| 58          | 136.4 | 1336.93    |
| 59          | 138.2 | 1289.26    |
| 60          | 140   | 1243.53    |
| 61          | 141.8 | 1199.7     |
| 62          | 143.6 | 1157.59    |
| 63          | 145.4 | 1117.18    |
| 64          | 147.2 | 1078.37    |
| 65          | 149   | 1041.15    |
| 66          | 150.8 | 1005.38    |
| 67          | 152.6 | 971.03     |
| 68          | 154.4 | 938.02     |
| 69          | 156.2 | 906.3      |
| 70          | 158   | 875.81     |
| 71          | 159.8 | 846.5      |
| 72          | 161.6 | 818.31     |
| 73          | 163.4 | 791.21     |
| 74          | 165.2 | 765.14     |
| 75          | 167   | 740.06     |

| TEMPERATURE |       | RESISTANCE |
|-------------|-------|------------|
| C           | F     | OHMS       |
| 76          | 168.8 | 715.93     |
| 77          | 170.6 | 692.68     |
| 78          | 172.4 | 670.34     |
| 79          | 174.2 | 648.82     |
| 80          | 176   | 628.09     |
| 81          | 177.8 | 608.11     |
| 82          | 179.6 | 588.88     |
| 83          | 181.4 | 570.36     |
| 84          | 183.2 | 552.5      |
| 85          | 185   | 535.29     |
| 86          | 186.8 | 518.7      |
| 87          | 188.6 | 502.7      |
| 88          | 190.4 | 487.28     |
| 89          | 192.2 | 474.4      |
| 90          | 194   | 458.06     |
| 91          | 195.8 | 444.2      |
| 92          | 197.6 | 430.85     |
| 93          | 199.4 | 417.96     |
| 94          | 201.2 | 405.51     |
| 95          | 203   | 393.49     |
| 96          | 204.8 | 381.89     |
| 97          | 206.6 | 370.69     |
| 98          | 208.4 | 359.87     |
| 99          | 210.2 | 349.41     |
| 100         | 212   | 339.32     |
| 101         | 213.8 | 329.55     |
| 102         | 215.6 | 320.12     |
| 103         | 217.4 | 311        |
| 104         | 219.2 | 302.18     |
| 105         | 221   | 293.65     |
| 106         | 222.8 | 285.41     |
| 107         | 224.6 | 277.43     |
| 108         | 226.4 | 269.72     |
| 109         | 228.2 | 262.26     |
| 110         | 230   | 255.03     |
| 111         | 231.8 | 248.04     |
| 112         | 233.6 | 241.28     |
| 113         | 235.4 | 234.72     |

| TEMPERATURE |       | RESISTANCE |
|-------------|-------|------------|
| C           | F     | OHMS       |
| 114         | 237.2 | 228.38     |
| 115         | 239   | 222.24     |
| 116         | 240.8 | 216.29     |
| 117         | 242.6 | 210.53     |
| 118         | 244.4 | 204.95     |
| 119         | 246.2 | 199.54     |
| 120         | 248   | 194.3      |
| 121         | 249.8 | 189.22     |
| 122         | 251.6 | 184.3      |
| 123         | 253.4 | 178.5      |
| 124         | 255.2 | 174.89     |
| 125         | 257   | 170.41     |
| 126         | 258.8 | 166.06     |
| 127         | 260.6 | 161.83     |
| 128         | 262.4 | 157.74     |
| 129         | 264.2 | 153.77     |
| 130         | 266   | 149.91     |
| 131         | 267.8 | 146.17     |
| 132         | 269.6 | 142.54     |
| 133         | 271.4 | 139.02     |
| 134         | 273.2 | 136.6      |
| 135         | 275   | 132.27     |
| 136         | 276.8 | 129.04     |
| 137         | 278.6 | 125.91     |
| 138         | 280.4 | 122.87     |
| 139         | 282.2 | 119.91     |
| 140         | 284   | 117.04     |
| 141         | 285.8 | 114.25     |
| 142         | 287.6 | 111.54     |
| 143         | 289.4 | 108.9      |
| 144         | 291.2 | 106.34     |
| 145         | 293   | 103.86     |
| 146         | 294.8 | 101.43     |
| 147         | 296.6 | 99.074     |
| 148         | 298.4 | 95.785     |
| 149         | 300.2 | 94.559     |
| 150         | 302   | 92.393     |

## 5.2 Screw Compressor Motor Protection

06T Screw compressors must be applied with properly sized calibrated circuit breakers or Furnas "958" series solid-state overload relays to protect the motor against overcurrent fault conditions. Approved selections are shown in section 5.3 for the 06TR and 06TA compressors. Use of motor protection devices other than those shown in this Application Manual must be approved by Carlyle Application Engineering. The use of authorized overcurrent protection is part of the basis of UL recognition. Selection of alternate overcurrent protection without Carlyle's approval will void warranty. For proper overcurrent protection, the must trip setting of the protection device must not exceed the compressor Maximum Must Trip Amps shown in the tables. The selected compressor overcurrent device must trip in 2 to 6 seconds at the LRA value shown for the compressor.

The circuit breakers and overload relays selected by Carlyle are manually reset and have been sized to protect the compressor against running overcurrent, locked rotor, primary and secondary single phasing. These devices also offer the additional advantage of protecting the compressor against malfunctions of the compressor contactor (which may not be possible with pilot duty motor protection).

Compressor overcurrent protection devices for part winding applications must trip the first 3 legs in 2 to 6 seconds and the second 3 legs in 1 to 3 seconds. Carlyle recommends a 1 to 1.25 second time delay between energizing the first and second legs. Consult Carlyle Application Engineering for part winding circuit breakers. Part winding circuit breakers are stocked in limited quantities by Carlyle and may require special order.

### ALLOWABLE OPERATING VOLTAGE RANGES

| Name Plate Voltage | Frequency (Hz) | Min. Voltage | Max. Voltage |
|--------------------|----------------|--------------|--------------|
| 208-230            | 60             | 187          | 264          |
| 200                | 50             | 180          | 230          |
| 230                | 50             | 198          | 264          |
| 460                | 60             | 396          | 528          |
| 400                | 50             | 342          | 456          |
| 575                | 60             | 495          | 660          |
| 400                | 60             | 342          | 460          |

## Section 5.3 Circuit Breaker Tables

| 06TR - ELECTRICAL SPECIFICATIONS |          |    |                          |        | RECOMMENDED OVERCURRENT PROTECTION |     |      |     |                                       |     |       |                     |  |  |
|----------------------------------|----------|----|--------------------------|--------|------------------------------------|-----|------|-----|---------------------------------------|-----|-------|---------------------|--|--|
| COMPRESSOR INFORMATION           |          |    |                          |        | CIRCUIT BREAKER                    |     |      |     |                                       |     |       |                     |  |  |
| COMPRESSOR MODEL                 | VOLTAGE  | HP | MAX MTA<br>(See Note #1) | LRA XL | CIRCUIT BREAKER PART #             | MH  | MTA  | LRA | CARLYLE FURNAS PART #<br>(See Note 4) | MH  | MTA   | RLA<br>(See Note 3) |  |  |
| 06TRC033C                        | 575      |    | 33.5                     | 114    | HH83XA460                          | 29  | 33.5 | 97  | HN76JZ015                             | 29  | 32.5  | 23.2                |  |  |
| 06TRC033B                        | 400/460  | 15 | 46                       | 142    | HH83XA463                          | 40  | 46   | 150 | HN76JZ022                             | 40  | 44.8  | 32                  |  |  |
| 06TRC033F                        | 208/230  |    | 90                       | 286    | HH83XB626                          | 78  | 90   | 250 | HN76JZ050                             | 80  | 89.6  | 64                  |  |  |
| 06TRD039C                        | 575      |    | 39                       | 138    | HH83XA461                          | 33  | 38   | 124 | HN76JZ022                             | 34  | 38.1  | 27.2                |  |  |
| 06TRD039B                        | 400/460  | 20 | 49                       | 173    | HH83XA424                          | 42  | 49   | 175 | HN76JZ022                             | 43  | 48.2  | 34.4                |  |  |
| 06TRD039F                        | 208/230  |    | 104                      | 348    | HH83XB625                          | 91  | 104  | 350 | HN76JZ050                             | 92  | 103   | 73.6                |  |  |
| 06TRD044C                        | 575      |    | 39                       | 138    | HH83XA461                          | 33  | 38   | 124 | HN76JZ022                             | 34  | 38.1  | 27.2                |  |  |
| 06TRD044B                        | 400/460  | 20 | 49                       | 173    | HH83XA424                          | 42  | 49   | 175 | HN76JZ022                             | 43  | 48.2  | 34.4                |  |  |
| 06TRD044F                        | 208/230  |    | 104                      | 348    | HH83XB625                          | 91  | 104  | 350 | HN76JZ050                             | 92  | 103   | 73.6                |  |  |
| 06TRE048C                        | 575      |    | 53                       | 172    | HH83XA469                          | 46  | 53   | 164 | HN76JZ022                             | 44  | 49.3  | 35.2                |  |  |
| 06TRE048B                        | 400/460  | 25 | 64                       | 215    | HH83XA426                          | 55  | 64   | 210 | HN76JZ033                             | 56  | 62.7  | 44.8                |  |  |
| 06TRE048F                        | 208/230  |    | 128                      | 433    | HH83XC509                          | 110 | 127  | 420 | HN76JZ075                             | 114 | 127.7 | 91.2                |  |  |
| 06TRE054C                        | 575      |    | 53                       | 172    | HH83XA469                          | 46  | 53   | 164 | HN76JZ022                             | 44  | 49.3  | 35.2                |  |  |
| 06TRE054B                        | 400/460  | 25 | 64                       | 215    | HH83XA426                          | 55  | 64   | 210 | HN76JZ033                             | 56  | 62.7  | 44.8                |  |  |
| 06TRE054F                        | 208/230  |    | 128                      | 433    | HH83XC509                          | 110 | 127  | 420 | HN76JZ075                             | 114 | 127.7 | 91.2                |  |  |
| 06TRF065C                        | 575      |    | 62                       | 219    | HH83XB617                          | 54  | 61   | 219 | HN76JZ033                             | 55  | 61.6  | 44                  |  |  |
| 06TRF065B                        | 400/460  | 30 | 76                       | 253    | HH83XA474                          | 67  | 78   | 274 | HN76JZ033                             | 66  | 73.9  | 52.8                |  |  |
| 06TRF065F                        | 208/230  |    | 154                      | 611    | HH83XC573                          | 134 | 154  | 611 | HN76JZ075                             | 136 | 152.3 | 108.8               |  |  |
| 06TRG078C                        | 575      |    | 72                       | 258    | HH83XB618                          | 63  | 72   | 258 | HN76JZ033                             | 64  | 71.7  | 51.2                |  |  |
| 06TRG078B                        | 400/460  | 35 | 89                       | 323    | HH83XA475                          | 74  | 89   | 323 | HN76JZ050                             | 78  | 87.4  | 62.4                |  |  |
| 06TRG078F                        | 208/230  |    | 181                      | 721    | HH83XC574                          | 158 | 181  | 721 | HN76JZ090                             | 160 | 179.2 | 128                 |  |  |
| 06TRH088C                        | 575      |    | 81                       | 296    | HH83XB619                          | 71  | 81   | 296 | HN76JZ050                             | 72  | 80.6  | 57.6                |  |  |
| 06TRH088B                        | 400/460  | 40 | 101                      | 370    | HH83XA476                          | 88  | 101  | 370 | HN76JZ050                             | 90  | 100.8 | 72                  |  |  |
| 06TRH088F                        | 208/230  |    | 203                      | 825    | HH83XC575                          | 179 | 203  | 825 | HN76JZ090                             | 180 | 201.6 | 144                 |  |  |
| 06TRK108B                        | 400-3-50 | 50 | 114                      | 440    | HH83XA477                          | 100 | 115  | 439 | HN76JZ050                             | 100 | 112   | 80                  |  |  |

### LEGEND

RLA=Rated Load Amps  
 LRA=Locked Rotor Amps  
 XL=Across-the-Line Start

PW=Part-Winding Start  
 MH=Must Hold Amps  
 MTA=Must Trip Amps

### NOTES:

- Compressor must trip amps are maximum figures. Overcurrent protection must trip at or below this value.
- LRA value for PW 2<sup>nd</sup> winding = 1/2 the LRA XL value.
- Recommended RLA value = Cr/Brk must trip value / 1.4. Use this recommended RLA value to determine minimum contactor sizing and wiring sizing. See also detail on Compressor Amperage Ratings on Unit Rating Plate.
- Alternate over current protection device which can be used in place of calibrated circuit breaker.
- Carlyle 06TR 400-3-50 units have the same circuit breaker table ratings as 460-3-60. Refer to 460-3-60 data for 50Hz information.

06TA - ELECTRICAL SPECIFICATIONS

| COMPRESSOR INFORMATION |         |    |                          | RECOMMENDED OVERCURRENT PROTECTION |                        |     |     |     |                                       |     |       |                     |
|------------------------|---------|----|--------------------------|------------------------------------|------------------------|-----|-----|-----|---------------------------------------|-----|-------|---------------------|
| COMPRESSOR MODEL       | VOLTAGE | HP | MAX MTA<br>(See Note #1) | LRA XL                             | CIRCUIT BREAKER PART # | MH  | MTA | LRA | CARLYLE FURNAS PART #<br>(See Note 4) | MH  | MTA   | RLA<br>(See Note 3) |
| 06TAD033C              | 575     |    | 39                       | 138                                | HH83XA461              | 33  | 38  | 124 | HN76JZ022                             | 34  | 38.1  | 27.2                |
| 06TAD033B              | 400/460 | 20 | 49                       | 173                                | HH83XA424              | 42  | 49  | 175 | HN76JZ022                             | 43  | 48.2  | 34.4                |
| 06TAD033F              | 208/230 |    | 104                      | 348                                | HH83XB625              | 91  | 104 | 350 | HN76JZ050                             | 92  | 103   | 73.6                |
| 06TAE039C              | 575     |    | 53                       | 172                                | HH83XA469              | 46  | 53  | 164 | HN76JZ022                             | 44  | 49.3  | 35.2                |
| 06TAE039B              | 400/460 | 25 | 64                       | 215                                | HH83XA426              | 55  | 64  | 210 | HN76JZ033                             | 56  | 62.7  | 44.8                |
| 06TAE039F              | 208/230 |    | 128                      | 433                                | HH83XC509              | 110 | 127 | 420 | HN76JZ075                             | 114 | 127.7 | 91.2                |
| 06TAF044C              | 575     |    | 62                       | 202                                | HH83XA430              | 50  | 58  | 168 | HN76JZ033                             | 52  | 58.2  | 41.6                |
| 06TAF044B              | 400/460 | 30 | 76                       | 253                                | HH83XA478              | 67  | 76  | 274 | HN76JZ033                             | 65  | 72.8  | 52                  |
| 06TAF044F              | 208/230 |    | 163                      | 510                                | HH83XC539              | 142 | 163 | 507 | HN76JZ075                             | 144 | 161.3 | 115.2               |
| 06TAF048C              | 575     |    | 62                       | 202                                | HH83XA430              | 50  | 58  | 168 | HN76JZ033                             | 52  | 58.2  | 41.6                |
| 06TAF048B              | 400/460 | 30 | 76                       | 253                                | HH83XA478              | 67  | 76  | 274 | HN76JZ033                             | 65  | 72.8  | 52                  |
| 06TAF048F              | 208/230 |    | 163                      | 510                                | HH83XC539              | 142 | 163 | 507 | HN76JZ075                             | 144 | 161.3 | 115.2               |
| 06TAG054C              | 575     |    | 78                       | 242                                | HH83XA453              | 68  | 78  | 236 | HN76JZ050                             | 69  | 77.3  | 55.2                |
| 06TAG054B              | 400/460 | 35 | 88                       | 305                                | HH83XA547              | 77  | 88  | 283 | HN76JZ050                             | 78  | 87.4  | 62.4                |
| 06TAG054F              | 208/230 |    | 182                      | 610                                | HH83XC532              | 158 | 182 | 590 | HN76JZ090                             | 162 | 181.4 | 129.6               |
| 06TAG065C              | 575     |    | 72                       | 258                                | HH83XB618              | 63  | 72  | 258 | HN76JZ050                             | 69  | 77.3  | 55.2                |
| 06TAG065B              | 400/460 | 35 | 89                       | 323                                | HH83XA475              | 74  | 89  | 323 | HN76JZ050                             | 78  | 87.4  | 62.4                |
| 06TAG065F              | 208/230 |    | 181                      | 721                                | HH83XC574              | 158 | 181 | 721 | HN76JZ090                             | 161 | 180.3 | 128.8               |
| 06TAH078C              | 575     |    | 81                       | 296                                | HH83XB619              | 71  | 81  | 296 | HN76JZ050                             | 72  | 80.6  | 57.6                |
| 06TAH078B              | 400/460 | 40 | 101                      | 370                                | HH83XA476              | 88  | 101 | 370 | HN76JZ050                             | 90  | 100.8 | 72                  |
| 06TAH078F              | 208/230 |    | 203                      | 825                                | HH83XC575              | 179 | 203 | 825 | HN76JZ090                             | 180 | 201.6 | 144                 |
| 06TAK088C              | 575     |    | 92                       | 351                                | HH83XB610              | 74  | 89  | 323 | HN76JZ050                             | 78  | 87.4  | 62.4                |
| 06TAK088B              | 400/460 | 50 | 114                      | 440                                | HH83XA477              | 100 | 115 | 439 | HN76JZ050                             | 100 | 112   | 80                  |
| 06TAK088F*             | 208/230 |    | 230                      | 974                                | HH83XC576              | 200 | 230 | 979 | HN76JZ050*                            | 100 | 112   | 160                 |

LEGEND

RLA=Rated Load Amps  
 LRA=Locked Rotor Amps  
 XL=Across-the-Line Start  
 PW=Part-Winding Start  
 MH=Must Hold Amps  
 MTA=Must Trip Amps

\* To use Furnas overload w/06TAK088F2EA-A00, compressor must be wired for part-winding start and 2 overloads wired in parallel with 2 contactors. Furnas must hold setting = 100. MTA Setting = 112.

NOTES:

- Compressor must trip amps are maximum figures. Overcurrent protection must trip at or below this value.
- LRA value for PW winding = 1/2 the LRA XL value.
- Recommended RLA value = Cr Brk must trip value / 1.4. Use this recommended RLA value to determine minimum contactor sizing and wiring sizing. See also detail on Compressor Amperage Ratings on Unit Rating Plate.
- Alternate over current protection device which can be used in place of calibrated circuit breaker.
- Carlyle 06TA 400-3-50 units have the same circuit breaker table ratings as 460-3-60. Refer to 460-3-60 data for 50Hz information.

## Section 6 — Motor and Discharge Temperature Control

### 6.1 Carlyle Electronic Module (CEM)

The Carlyle solid-state electronic module (115v-1-50/60 or 240v-1-50/60) is used for primary control of the compressor contactor, oil and economizer line solenoids, and unloader and Vi coils. It also provides compressor thermal safety protection.

Two versions of this module have been used. The original Carlyle Electronic Module (CEM) and the LonCEM Module. Both versions are covered in detail in Appendix A and Appendix B of this manual.

### 6.2 Discharge Temperature Control

Discharge temperature control and high temperature protection are supplied by the CEM. There are some applications where the discharge temperature becomes so hot that it is necessary to inject liquid directly into the screw rotors. This is accomplished through the use of a constant temperature desuperheating valve. Refer to section 3.7 for selection and application of this valve. The desuperheating valve bulb must be strapped to the discharge line (as close to the service valve as possible) and insulated. The valve will maintain a discharge temperature of 190°F (88°C). A normally closed solenoid with an inlet strainer is required upstream of the expansion valve.

**The liquid feed header must be sized for the entire desuperheating and motor cooling load. Failure to do so can lead to compressor overheating during high ambient operation.**

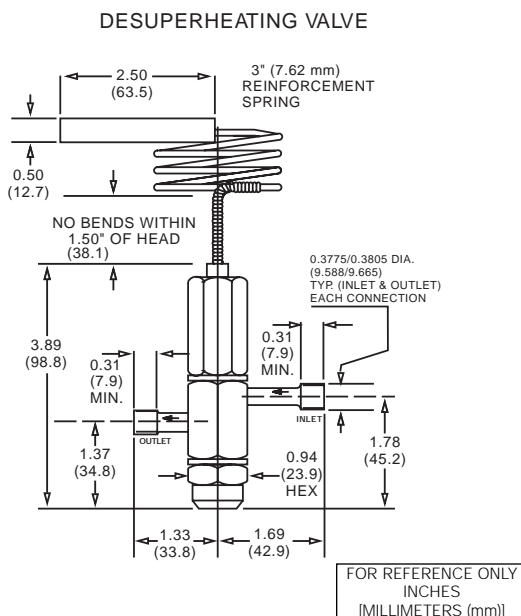

### 6.3 Motor Cooling Control

Motor cooling control and high temperature protection are supplied by the LonCEM/CEM. Carlyle 06T screw compressors utilize an economizer cooled motor. Screw compressor technology allows access to intermediate pressure part way through the compression cycle. The Carlyle screw compressor uses this intermediate pressure access to pull vapor through a subcooler and over the compressor motor. This process (called an economizer cycle) provides liquid subcooling and motor cooling (reducing the need for liquid injection). Due to both these processes being done at an intermediate pressure versus suction pressure, significant increases in energy efficiency are realized.

A typical economizer arrangement is shown below. The flow to the screw compressor motor is governed by an expansion valve that is set to maintain 10 to 20°F (6 to 11°C) superheat above intermediate pressure. A liquid line solenoid is required in front of the expansion valve and must be normally closed (this valve must be off when all compressors are off and on when any compressor is on).

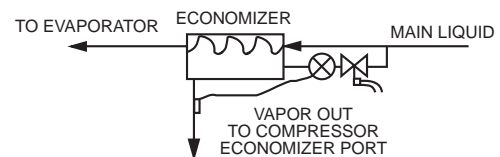

For parallel applications, an intermediate header is required to distribute economizer gas to each compressor. A solenoid valve is required in the feed line to each compressor. This valve must be normally closed and off when the compressor is off to eliminate intermediate to suction pressure leak back during any compressor off cycle. This solenoid can be controlled by the CEM.

If an economizer is not used, motor cooling control is still required. Two cooling valves should be installed in parallel, feeding the economizer port to eliminate thermal shock. One EF28BZ005 (1 ton) valve is wired to be on any time the compressor is on and the LonCEM controls one EF28BZ007 (1.5 ton) valve.

Motor barrel insulation is recommended on compressors with suction temperatures below -15°F (-26°C) to prevent frost build-up and condensation on the compressor motor barrel.

## Section 7 — Subcooler Selection and Performance Data Adjustment

### 7.1 Subcooler Selection

The use of an economizer is highly recommended and provides the high capacities and energy efficiencies shown in the screw compressor tabular rating tables. The subcooling load may be calculated by taking the total compressor mass flow of the rack and multiplying it by the change in enthalpy across the subcooler (liquid main in minus liquid main out). To estimate the liquid temperature leaving the subcooler, take the saturated intermediate temperature (at the design condition) from the performance tables and add 10°F (5°C). The subcooler should now be sized based on the subcooling load calculated. Carlyle recommends sizing and piping the subcooler for parallel flow. Parallel flow through the subcooler results in better control of the subcooler TXV (reduces TXV hunting).

### 7.2 Subcooling Correction

The economized performance data supplied is based on liquid temperature that is 10°F (6°C) above saturated intermediate temperature. The capacity may be varied for other than rated liquid temperature by either of two methods. For the most accurate adjustment, Method #2 should be used.

#### METHOD 1

Vary compressor capacity by 3% for each 10°F (6°C) difference between actual and rated liquid temperature. For example, if the actual liquid temperature was 50°F (10°C) and the rated liquid temperature was 40°F (5°C), divide the rated capacity by 1.03. This method is specifically for R-22.

#### METHOD 2

Using the mass flow rates published in the rating tables, a thermodynamic correction may be used by calculating the new change in enthalpy across the evaporator and multiplying it by the evaporator mass flow rate.

### 7.3 Superheat Correction

The screw compressor tabular data is rated with 65°F (18°C) return gas temperature (all useful superheat) for low and medium temperature applications. The suction gas does not pass over the motor, but goes directly to the compressor rotors. Utilizing R-22 the compressor capacity will have no significant change

with lower return gas temperatures based on all useful superheat at the compressor. However, the actual *evaporator capacity* will increase with lower return gas temperature due to the higher gas density entering the compressor which will result in larger compressor mass flow rates. Mass flow rates are published in the compressor performance tables and may be used to calculate compressor performance at any approved operating condition. The Carlyle screw compressor suction gas goes directly into the rotors and therefore does not incur additional (inefficient) suction gas superheating from passing over the motor. There is a required minimum of 20°F (11°C) discharge superheat. The system should sound an alarm if the superheat reaches 20°F (11°C). Long periods of run time with low discharge superheat will reduce compressor bearing life.

### 7.4 Carlyle Software

The Carlyle Compressor Selection program “**CARWIN**” will select compressors, calculate subcooler load, oil-cooler load, and perform superheat and subcooling corrections. This software is available through Carlyle Compressor Company, at [www.carlylecompressor.com](http://www.carlylecompressor.com).

The tabular performance data presented in this catalog is at 65°F(18.3°C) return gas temperature and SIT+10°F(5.5°C) liquid temperature. Performance at actual operating conditions may vary significantly from these rating conditions. Our Carwin selection software can be used to estimate the performance at the actual operating conditions.

For systems that have mechanical subcooling, as with the economizer cycle on our 74mm compressors, there can be a substantial difference between the performance at the standard rating conditions and the applications actual operating conditions. These differences are generally only significant in low temperature applications. For low temperature applications (SST<0°F/4.4°C), compressor performance should be based on design liquid temperature (typically maintained at or above 40°F(4.4°C) and the maximum return gas temperature expected (typically 25°F-35°F (-3.8°C-1.7°C) for low temperature applications). The evaporator refrigeration effect (ERE reported in Carwin) capacity should then be used to size against the required load.



# Section 8 — 05T Open Drive Application Information

## 8.1 General Information

The 05T compressor is a compact and light-weight open drive screw compressor which delivers high capacity for its size. It is very similar to the 06T semi-hermetic screw compressor. With the exception of an internal motor, the 05T and 06T are virtually identical. In place of the internal motor, the open drive is supplied with a gear casing and jack shaft to connect an external C-Face motor or other device. The compression end of the compressor is identical to the 06T semi-hermetic screw compressor.

The compressor is designed for operation at both 1750 rpm at 60 Hz (1450 rpm @ 50 Hz) and 3500 rpm at 60 Hz (2900 rpm @ 50 Hz). With the exception of electrical information and motor cooling requirements of the 06T compressor, all the information in this application guide also applies to the 05T models. An external oil cooler is required on all applications where the discharge temperature is above 170 F. The model numbering system, however, is slightly different. The cross reference can be found in the table below.

| 06T Model # | 05T Model # | RPM<br>60Hz (50Hz) | Ft <sup>3</sup> /min<br>@ 60Hz | m <sup>3</sup> /min<br>@ 50Hz |
|-------------|-------------|--------------------|--------------------------------|-------------------------------|
| 06T**033    | 05TRQ033    | 1750 (1450)        | 33                             | .78                           |
| 06T**039    | 05TRQ039    | "                  | 39                             | .92                           |
| 06T**044    | 05TRQ044    | "                  | 44                             | 1.04                          |
| 06T**048    | 05TRQ048    | "                  | 48                             | 1.13                          |
| 06T**054    | 05TRQ054    | "                  | 54                             | 1.28                          |
| 06T**065    | 05TRQ033    | 3500 (2900)        | 65                             | 1.53                          |
| 06T**078    | 05TRQ039    | "                  | 78                             | 1.84                          |
| 06T**088    | 05TRQ044    | "                  | 88                             | 2.08                          |

**Model Number Cross Reference**

The 05T compressor has been designed for direct drive duty and should not be used in a belt drive application.

## 8.2 Compressor Dimensions

Like the 06T, the 05T models have all the same physical dimensions. Please review dimensional drawings for external dimensional information on the compressor.

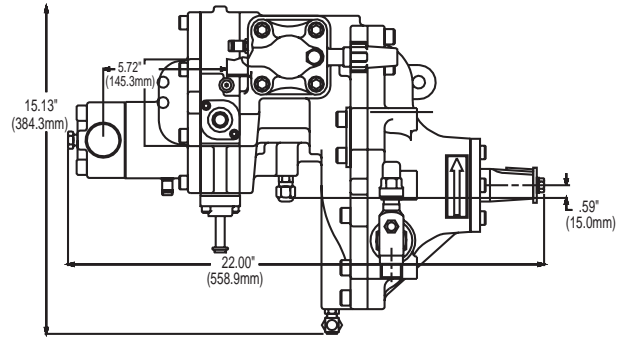

FOR REFERENCE ONLY  
INCHES  
[MILLIMETERS (mm)]

**Dimensions (Top View)**

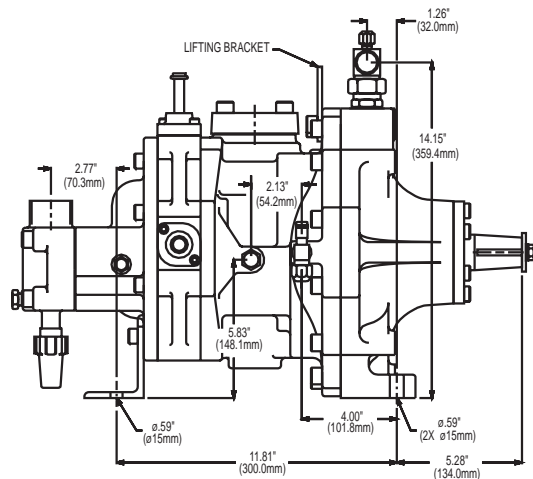

FOR REFERENCE ONLY  
INCHES  
[MILLIMETERS (mm)]

**Dimensions (Side View)**

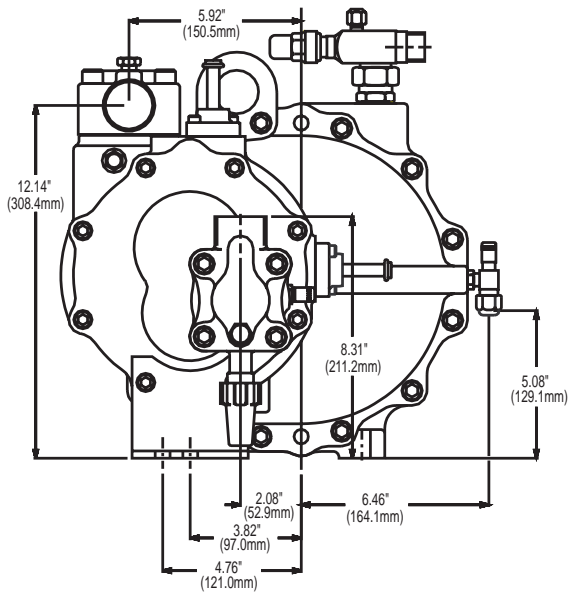

FOR REFERENCE ONLY  
INCHES  
[MILLIMETERS (mm)]

**Dimensions (Bottom View)**

| Motor Selection   | Speed                              | C-Flange Package Required | Dimensions         |
|---|------------------------------------|---------------------------|--------------------|
| 15Hp (254TC)<br>20Hp (256TC)<br>25Hp (284TC)<br>30Hp (286TC)                      | 1750 rpm @ 60Hz<br>1450 rpm @ 50Hz | OTA0929                   | C-flange drawing A |
| 40Hp (324TC)<br>50Hp (326TC)  | 1750 rpm @ 60Hz<br>1450 rpm @ 50Hz | OTA0930                   | C-flange drawing B |
| 30Hp (286TSC)<br>40Hp (324TSC)<br>50Hp (326TSC)<br>60Hp (364TSC)<br>75Hp (365TSC) | 3500 rpm @ 60Hz<br>2900 rpm @ 50Hz | OTA0931                   | C-flange drawing C |

Please review C-Flange dimension drawings for all dimensional information on the C-Flanges.

### 8.3 Compressor C-Flange

Several compressor C-Flanges have been designed by Carlyle. The C-Flange bolts to both the compressor and a C-Face motor for easy self aligning (within  $\pm 0.005$ " [.127mm] TIR) of the coupling. There are three distinct C-Flanges, two for 1750 (1450) RPM motors and one for 3500 (2900) RPM motors. The C-Flange selections can be found in the following table.

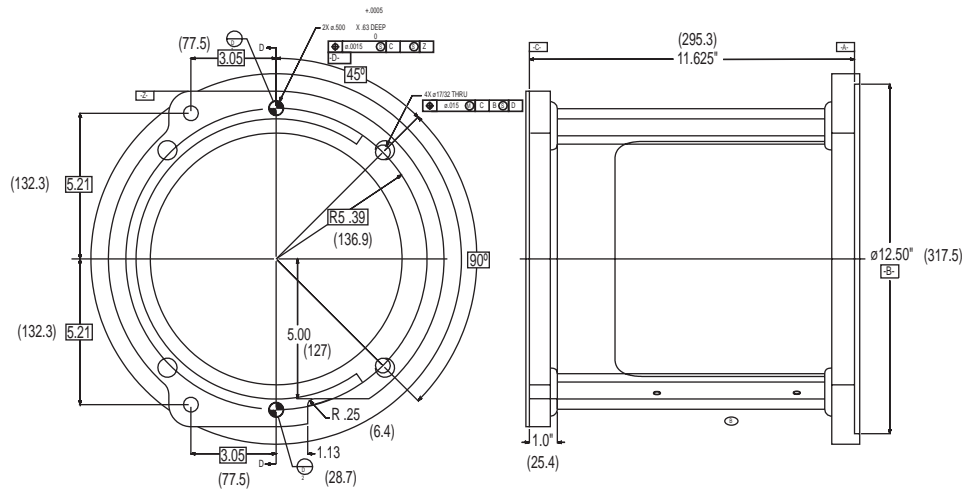

**C-Flange Dimensions (A)**

FOR REFERENCE ONLY  
INCHES  
[MILLIMETERS (mm)]

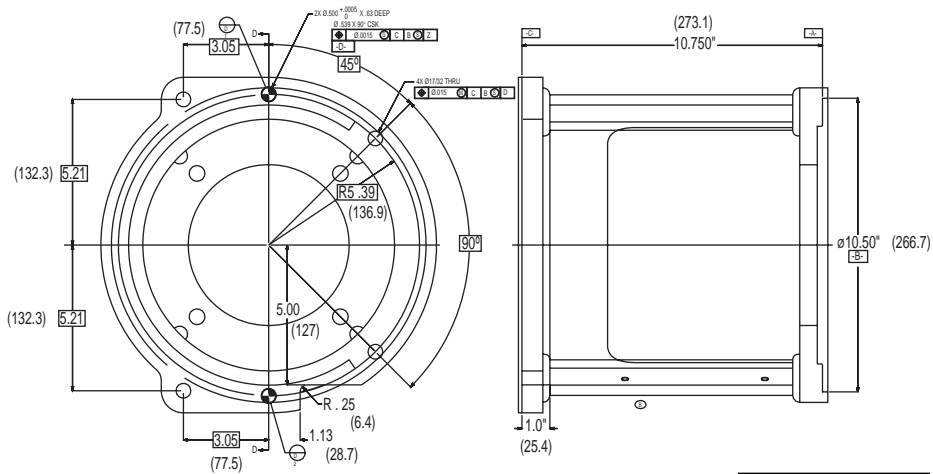

**C-Flange Dimensions (B)**

FOR REFERENCE ONLY  
INCHES  
[MILLIMETERS (mm)]

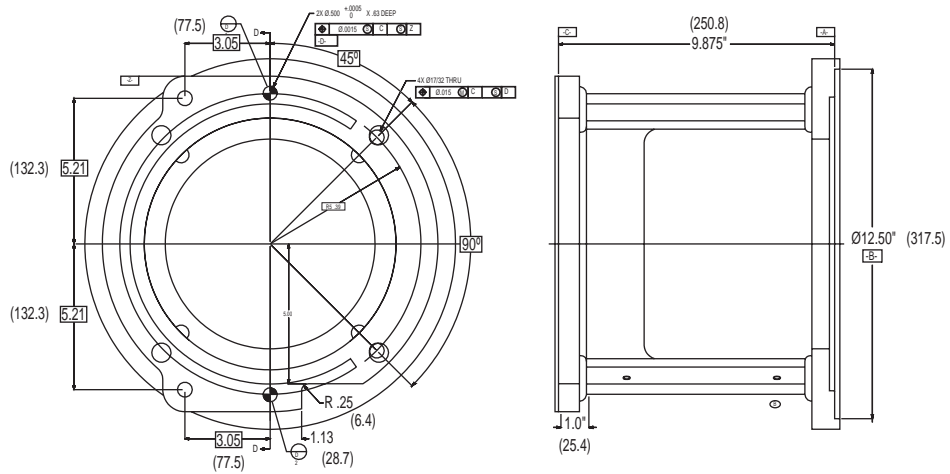

**C-Flange Dimensions (C)**

FOR REFERENCE ONLY  
INCHES  
[MILLIMETERS (mm)]

## 8.4 Compressor Coupling

A flexible Dodge coupling is used to direct couple the compressor to the motor shaft. To properly assemble the C-Flange and coupling onto the compressor, follow the installation instructions for C-Flange and coupling supplied with the C-Flange packages.

The required coupling for each different motor size can be found in the following table. The coupling dimensions can be found in the figure below.

| Motor Selection  | Speed                              | Motor Shaft Dia. (Inch) | Coupling Package Required |
|--|------------------------------------|-------------------------|---------------------------|
| 15Hp (254TC)<br>20Hp (256TC)                                     | 1750 rpm @ 60Hz<br>1450 rpm @ 50Hz | 1-5/8                   | 8TA0868B                  |
| 25Hp (284TC)<br>30Hp (286TC)                                     | 1750 rpm @ 60Hz<br>1450 rpm @ 50Hz | 1-7/8                   | 8TA0869B                  |
| 40Hp (324TC)<br>50Hp (326TC)                                     | 1750 rpm @ 60Hz<br>1450 rpm @ 50Hz | 2-1/8                   | 8TA0870B                  |
| 30Hp (286TSC)  | 3500 rpm @ 60Hz<br>2900 rpm @ 50Hz | 1-5/8                   | 8TA0868B                  |
| 40Hp (324TSC)<br>50Hp (326TSC)<br>60Hp (364TSC)<br>75Hp (365TSC) | 3500 rpm @ 60Hz<br>2900 rpm @ 50Hz | 1-7/8                   | 8TA0869B                  |

## 8.5 Overall Dimensions

All the 05T compressors have the same external physical dimensions, therefore the variables that will affect the overall dimensions of the assembly are the motor and C-Flange. The dimensional drawing shown in the 05T dimension drawing supplies the assembly dimensions with the different C-Flanges and motors.

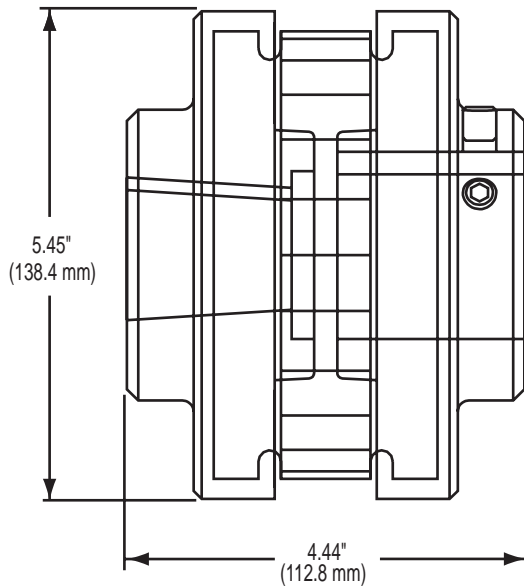

FOR REFERENCE ONLY  
INCHES  
[MILLIMETERS (mm)]

**Coupling Dimensions**

| C-Flange Package | HP | Motor RPM. | NEMA Frame | A     |       | B    |       | C     |       | D    |      | E   |      |
|------------------|----|------------|------------|-------|-------|------|-------|-------|-------|------|------|-----|------|
|                  |    |            |            | in.   | cm.   | in.  | cm.   | in.   | cm.   | in.  | cm.  | in. | cm.  |
| OTA0929          | 15 | 1750       | 254TC      | 8.25  | 20.96 | 5.00 | 12.70 | 27.29 | 69.32 | .106 | .28  | .56 | 1.42 |
|                  | 20 | 1750       | 256TC      | 10.00 | 25.40 | 5.00 | 12.70 | 27.29 | 69.32 | .106 | .28  | .56 | 1.42 |
|                  | 25 | 1750       | 284TC      | 9.50  | 24.13 | 5.50 | 13.97 | 27.48 | 69.80 | .858 | 2.18 | .56 | 1.42 |
|                  | 30 | 1750       | 286TC      | 11.00 | 27.94 | 5.50 | 13.97 | 27.48 | 69.80 | .858 | 2.18 | .56 | 1.42 |
| OTA0930          | 40 | 1750       | 324TC      | 10.50 | 26.67 | 6.25 | 15.88 | 28.86 | 73.30 | 1.86 | 4.72 | .69 | 1.75 |
|                  | 50 | 1750       | 326TC      | 12.00 | 30.48 | 6.25 | 15.88 | 28.86 | 73.30 | 1.86 | 4.72 | .69 | 1.75 |
| OTA0931          | 30 | 3500       | 286TSC     | 11.00 | 27.94 | 5.50 | 13.97 | 26.42 | 67.11 | .858 | 2.18 | .56 | 1.42 |
|                  | 40 | 3500       | 324TSC     | 10.50 | 26.67 | 6.25 | 15.88 | 27.11 | 68.86 | 1.86 | 4.72 | .69 | 1.75 |
|                  | 50 | 3500       | 326TSC     | 12.00 | 30.48 | 6.25 | 15.88 | 27.11 | 68.86 | 1.86 | 4.72 | .69 | 1.75 |
|                  | 60 | 3500       | 364TSC     | 11.25 | 28.58 | 7.00 | 17.78 | 27.73 | 70.43 | 2.86 | 7.26 | .69 | 1.75 |
|                  | 75 | 3500       | 365TSC     | 12.25 | 31.12 | 7.00 | 17.78 | 27.73 | 70.43 | 2.86 | 7.26 | .69 | 1.75 |

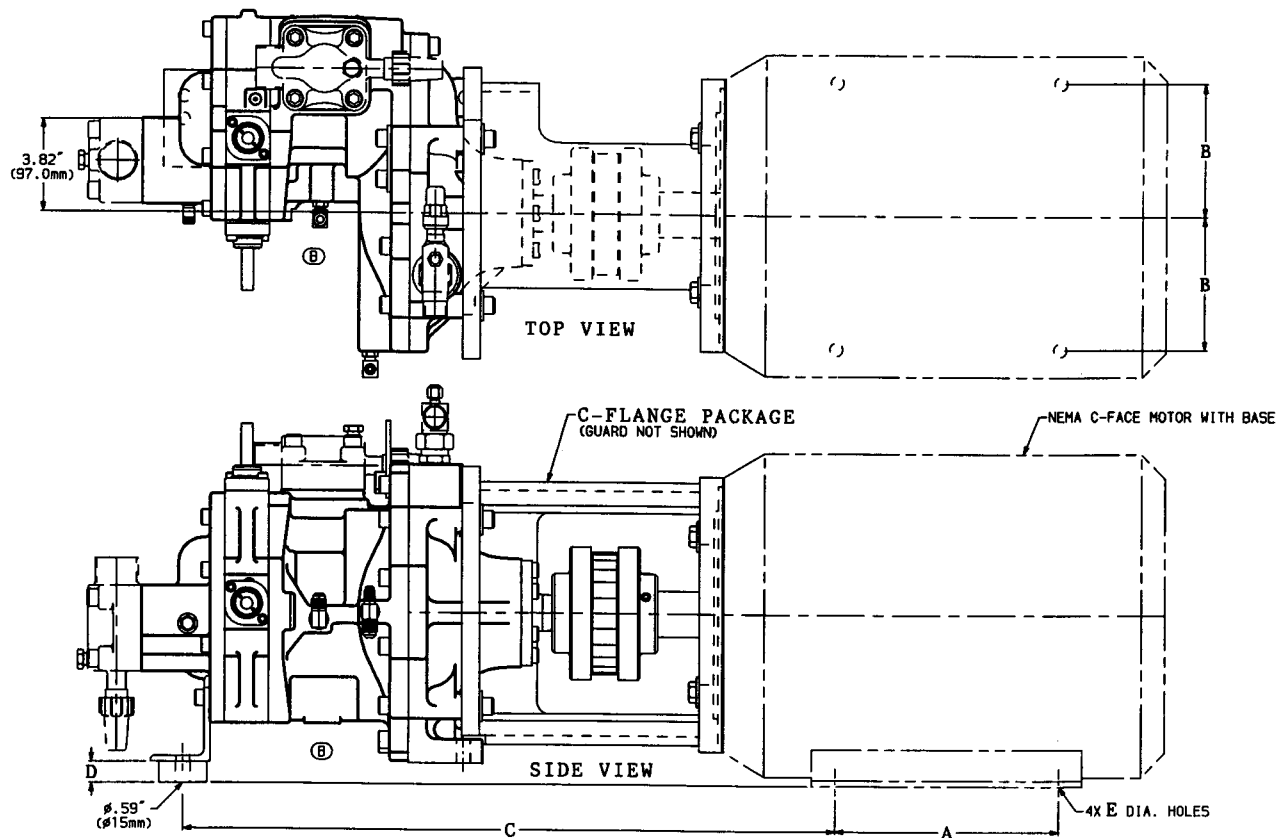

FOR REFERENCE ONLY  
INCHES  
[MILLIMETERS (mm)]

**05T Dimensions**

## 8.6 Carlyle Electronic Module

The LonCEM or Carlyle Electronic Module (CEM) should be used as noted in section 6 with the following exception. The motor and common termination on the module must be jumpered with a standard 5K resistor. This allows the module to maintain all of its functionality with the exception of motor cooling and motor over temperature control. The motor cooling valve will still be required. It should be piped into the economizer service valve to inject liquid should the discharge become too hot.

## 8.7 Motor Selection

Please refer to the Carlyle performance data for the brake horsepower required for your application. The performance data displays compressor capacity with a return gas temperature of 65°F (18°C) for all conditions in both the economized and non-economized tables. It does not give the actual evaporator refrigeration effect. The liquid temperature at the evaporator expansion valve is equal to the saturated condensing temperature for the non-economized data and the saturated interstage temperature plus 10°F (5.6°C) for the economized data. Please refer to the latest Carlyle Compressor CarWin selection software for more detailed compressor capacity information.

The 33, 39, 44, 48 and 54 cfm compressors all require 1750 rpm 4 pole motors @ 60 Hz (1450 rpm @ 50 Hz) while the 65, 78 and 88 cfm compressors use 3500 rpm 2 pole motors @ 60 Hz (2900 rpm @ 50 Hz). The motor must be a C-Face motor in order to mount with the C-Flange.

Although screw compressors have lower frictional torque requirements than normal reciprocating compressors, the screw compressor can have high starting torque levels. This is especially true when the suction pressure is high. A reciprocating compressor will open and close its reed valves according to pressure in the compression chamber versus the suction side (down stroke) or discharge side (up stroke). With a screw compressor, the suction gas will be fully compressed regardless of the suction and discharge pressures relative to the compression pocket. This is because there are no discharge reeds to open the pocket to discharge when the pressure in the compression pocket exceeds the discharge pressure.

Carlyle recommends the use of a high start torque C-Face motor to ensure starting of the compressor. **The motor starting torque should supply a minimum 170% of motor full load torque.** Higher torque values may be necessary, especially for low temperature R-404A/R-507 applications. Also, select a motor which can handle the pulldown required for the application, especially for low temperature applications. The motor should be able to handle the break horsepower required for a minimum of 20°F (11.1°C) saturated suction temperature, **above** design saturated suction temperature at design saturated condensing temperature.

## 8.8 Performance Factors

The design of a screw compressor lends itself to variable speed technology. The table below lists the minimum and maximum speed limits for each model compressor. These speed limits apply to electric motors or any other source used to drive the compressor.

| <b>05T Model</b> | <b>#CFM</b> | <b>Motor Speed Input Shaft 60Hz (50Hz) (RPM)</b> | <b>Min. Speed (RPM)</b> | <b>Max. Speed (RPM)</b> |
|------------------|-------------|--|-------------------------|-------------------------|
| 05TRQ033         | 33          | 1750 (1450)                                      | 1450                    | 4000                    |
|                  | 65          | 3500 (2900)                                      |                         |                         |
| 05TRQ039         | 39          | 1750 (1450)                                      | 1167                    | 4000                    |
|                  | 78          | 3500 (2900)                                      |                         |                         |
| 05TRQ044         | 44          | 1750 (1450)                                      | 1020                    | 3600                    |
|                  | 88          | 3500 (2900)                                      |                         |                         |
| 05TRQ048         | 48          | 1750 (1450)                                      | 875                     | 3300                    |
| 05TRQ054         | 54          | 1750 (1450)                                      | 875                     | 2930                    |

When using an inverter or other variable speed device, it is important to remember that over-speeding above the rated condition will result in an increased brake horsepower requirement. The brake horsepower will be comparable to 1.05% above the rated brake horsepower multiplied by the ratio of the design speed to the rated speed.

$$\text{DESIGN BHP} = (1.05) \left( \frac{\text{DESIGN SPEED}}{\text{RATED SPEED}} \right)$$

The 05T performance data has several items which should be considered when selecting the proper compressor and motor size.

1. The 33-54 cfm model's performance data is based on 1750 rpm @ 60 Hz
2. The 65-88 cfm model's performance data is based on 3500 rpm @ 60 Hz
3. 65°F (18°C) return gas temperature is used for all conditions and all the superheat is considered useful
4. The economized data is subcooled to the saturated interstage temperature plus 10°F (5.6°C)

The evaporator refrigeration effect will be less than the published compressor capacity if nonuseful superheat is generated in the return gas lines to the compressor.

The oil cooling requirement will be very similar to the oil cooling requirement for the 06T compressor. Use the calculation from the Carlyle electronic compressor selection program to determine the oil cooling requirement.

## Section 9 — Start-Up Procedure

### 9.1 Oil Charging Procedure

The oil cooler must be filled with oil. The oil separator should be filled to the top sight glass. Pulling a vacuum on the oil separator and drawing oil into the system through the oil header is recommended for ease of oil charging. This method will also fill the oil header.

See section 3.3 for information on system oil charge, and section 1.4 for approved oil types.

### 9.2 Testing the Control Circuit

Before testing the control circuit make sure all service valves, ball valves and solenoid valves are closed (with solenoid valves check to make sure they are not manually open). Test the control circuit verifying the operation of all time delays and the economizer and oil feed line solenoids.

### 9.3 Pre-Start-Up Check List

1. Open suction, discharge and economizer service valves (also any service valves upstream of liquid injection valves).
2. Open service valves in the oil feed lines.
3. Check high and low pressure switches for proper settings and ensure they are wired into the compressor control circuit. The high and low pressure switches must be connected to the compressor body, not at the service valves or piping.
4. Check the reverse rotation protection switch (low-pressure switch) to ensure that it is connected to the compressor high pressure switch port and that it is wired into the compressor control circuit. The switch must be located above the compressor high pressure switch port location. 1/4" tubing must be used for the pressure switch connection. Do not use capillary tubing as this may cause a time delay in the trip setting. (This does not apply to systems using the newer LonCEM Module or pressure transducer connections for newer LonCEM).
5. Check oil pressure differential switch to ensure that it is connected in the proper location (high side on the pressure discharge and low side at the oil inlet connection port). Oil pressure cut-out must be set at 45 psid (3 bar) with a 45-second time delay.
6. Check the LonCEM or Carlyle Electronic Module and ensure that it is properly wired into the control circuit and compressor.
7. The Heinemann/Airpax calibrated circuit breakers recommended in this application guide are required for each compressor or a Carlyle Application Engineering approved equivalent.
8. Connect a service gage to the compressor discharge port (at the high pressure switch connection location). **Caution:** The compressor has an internal check valve, therefore the gage must be connected to the high pressure switch port. Connect a service gage to the oil feed manifold between the oil line solenoid and the compressor. (Another alternative is at oil fitting at back of motor).
9. Check direction of rotation of the compressor. Proper rotation is critical. If the compressor is operated in reverse, severe damage may occur. To check for proper rotation follow the steps in Section 9.4.



## 9.4 Start-Up Worksheet

1. While monitoring the discharge gage (located on the high pressure connection port on the compressor body, not the discharge service valve), bump the compressor (turn the power on for 1/2 to 1 second). If the discharge pressure increases, the direction of rotation of the compressor is correct. If the discharge pressure drops, the compressor is experiencing reverse rotation and the phase sequence must be reversed. The phase sequence may be changed by switching any two leads at the compressor motor. (If a variable speed drive is used, see Step 2.)

Discharge pressure reading when bumped: \_\_\_\_\_

2. *Warning:* If a variable speed drive is used, the rotation of the compressor must be checked (as noted in Step 1) both with the inverter and through inverter bypass. When bumping the compressor with the inverter, watch the service gage carefully as it may take 1–5 seconds for significant rotation to occur. The phase sequence entering the variable speed drive may not be the same as the phase sequence leaving the variable speed drive. If the compressor rotation is incorrect both through the inverter and in bypass mode, any two leads must be switched at the compressor. If only the inverter or bypass mode is experiencing incorrect rotation, any two leads leaving the device causing reverse rotation must be switched. After any wiring change the compressor rotation must be checked both with the inverter and in bypass mode.
3. If a variable speed drive is used and the compressor will not start within 10 seconds, shut down the compressor and check the inverter size and logic.
4. After rotation has been verified prior to running the compressor, ensure gages have been connected to the oil feed manifold (between oil line solenoid and compressor). Upon start-up, immediately check oil pressure (difference between oil feed pressure and suction) to ensure that it is greater than 45 psid (3 bar). If oil pressure is less than 45 psid (3 bar), shut compressor off and check all oil line valves, filters, oil level and head pressure. Check the oil pressure drop across the oil filter. If the pressure drop exceeds 45 psid (3 bar), change the filter element.  
Oil Filter Inlet (Psi): \_\_\_\_\_ Oil Manifold Pressure: \_\_\_\_\_  
Oil Filter Outlet (Psi): \_\_\_\_\_ Suction Pressure (Psi): \_\_\_\_\_  
Pressure Differential: \_\_\_\_\_ Oil Pressure (Psi): \_\_\_\_\_
5. During compressor operation ensure that the economizer solenoid (if the economizer is used), liquid injection solenoid and oil line solenoid (taking into account the time delay) are energized and de-energize on shut down.
6. If an economizer is used, set the superheat leaving the subcooler to 6°F to 15°F (3°C to 9°C).  
Subcooler Vapor Pressure: \_\_\_\_\_  
Saturation Temperature: \_\_\_\_\_  
Superheat: \_\_\_\_\_
7. Check the oil temperature entering the compressor and ensure that it is less than 190°F (88°C).  
Oil Temperature: \_\_\_\_\_
8. Check functionality of the LonCEM/Carlyle Electronic Module:
  - Disconnect either 5K thermistor from the LonCEM/CEM to verify that the compressor will not start and all solenoid valves stay off.
  - Check to ensure that the motor cooling valve will feed (head pressure may have to be manually raised).

## Section 10 — Accessory Part Numbers

| Quantity Per System  |   |                     | Quantity Per Compressor |                               |  |
|----------------------|---|---------------------|-------------------------|-------------------------------|--|
| Qty.                 | Accessory Part Number                   |                     | Qty.                    | Accessory                     | Part Number  |
| 1                    | Oil Separator                           |                     | 1                       | Circuit Breaker               | HH83X . . .  |
|                      | Multiple Compressor System              |                     | 1                       | Oil Press. Diff. Sw.          | HK06ZB006†   |
|                      |   | KH31ZZ212           |                         | Older Systems                 | HK06ZB001  |
|                      | Single/Two Compressor System            |                     | 1                       | Rev. Rotation Sw.             | HK01CB002†   |
|                      |   | KH31ZZ340           |                         | Older Systems                 | HK01CB001  |
| 1                    | Oil Level Switch                        | HK13LB004           | 1                       | Muffler                       | LM10HH162  |
| 1                    | Heater                                  | HT38KN007           | 1                       | C.E.M.                        | 3TA0796B†  |
| 1                    | Oil Cooler*                             | KH51ZZ181           | 1                       | LonCEM††                      | OTA1063  |
|                      |   | KH51ZZ182           | 1                       | 5K Thermistor                 | HH79NZ065  |
|                      |   | KH51ZZ183           | 1                       | Motor Cool. Valve             | EF28BZ007  |
|                      |   | KH51ZZ184           | 1,2 or 3                | Solenoid Coil for:            |  |
| 1                    | Oil Filter Diff. Sw.                    | HK06CA051†          |                         | Unloader, Vi or oil solenoid: |  |
| 2                    | Oil Filter Housing                      | KH18MG002           |                         | EF19ZE (120,240,024)          |  |
| 4                    | Oil Filter Cartridge                    | KH39MG002           |                         | For motor cool. valve:        |  |
| 1                    | Oil Solenoid Valve/<br>Sight Glass asm. | EF23ZZ025           |                         | P510-XV (024,120,208) D       |  |
| 1                    | Subcooler***                            |                     | 05T Open Drive Add      |                               |  |
| 15 gal.<br>(approx.) | POE Oil                                 | Castrol E100        | 1                       | C Flange Package              | OTA0929  |
|                      |   | CPI Solest 120      |                         |                               | OTA0930  |
|                      |   | ICI Emkarate RL100S |                         |                               | OTA0931  |
|                      |   | CPI Solest 170**    | 1                       | Coupling                      | 8TA0868B   |
|                      |   |                     |                         |                               | 8TA0869B   |
|                      |   |                     |                         |                               | 8TA0870B   |
|                      |   |                     | 1                       | Desuperheating<br>Valve       | EA02ZD001- 1 ton,<br>002-1.5 ton,<br>030-2 ton,<br>050-3 ton,<br>100-5 ton |
|                      |   |                     | 1                       | Motor Cooling Valve           | EF25BZ007  |

\* May not be required if desuperheat valves can be used

† Items not required for use with LonCEM

\*\* Required for R-22 systems without external oil cooler.  
Not recommended for use with systems using an oil cooler.

\*\*\* Required for Economized Systems

†† See Appendix A for a breakdown of LonCEM package components (i.e. pressure transducers, thermistor, fitting sets.)

### Economizer & Oil Line Solenoid Valves

Solenoid valves are required in the oil and economizer line to each compressor. **The oil solenoid valve must be equipped with an inlet strainer and have an internal port diameter of at least 5/16 inch.**

### Service Valves

All new OEM compressors include suction, discharge and economizer service valves along with a 3/8" male flare oil line connection.

### Safety Switches and Pressure Connections

Two cross fittings are supplied with each LonCEM module package, which are to be installed in the suction and discharge access ports.

Each fitting yields (3) 1/4" male flare connections when installed. One of the connections has a schrader valve and cap, which is to be used for field gauge connections. The other two fittings (which do not have schrader valves) are to be used for the pressure transducer and the low/high pressure switch, respectively. See section 3.2 of the LonCEM Installation instructions (which follows in Appendix A) for more details on the access ports.

### 05T CEM

For open drive compressors, the CEM motor cooling valve output will control a motor cooling valve which injects liquid directly into the inter-stage service valve port. A 5K resistor will be required as a jumper in place of the motor 5K thermistor.

# APPENDIX A



## LonCEM<sup>®</sup>

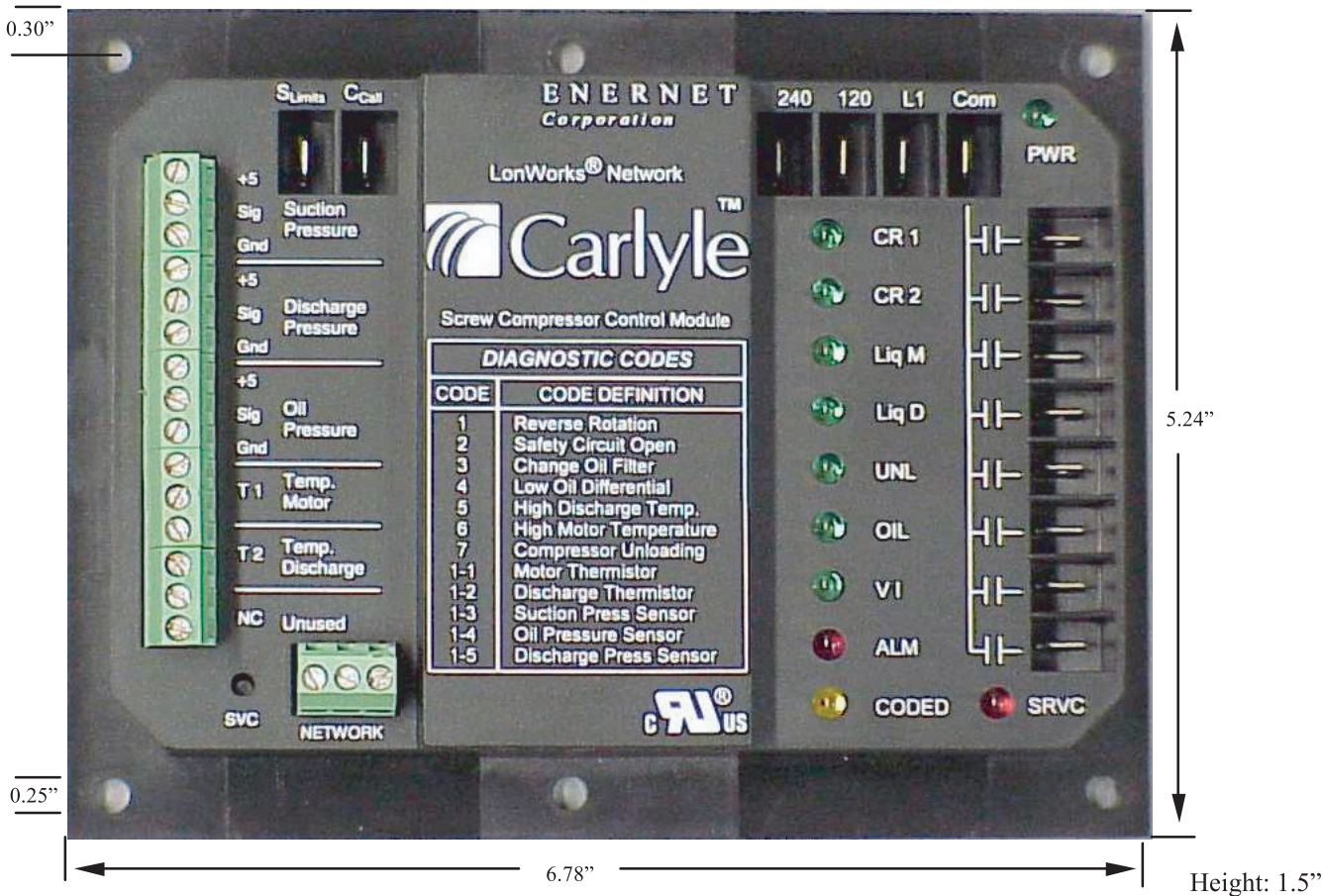

## Table of Contents

|   | <u>Page</u> |
|---|-------------|
| 1.0 Overview  | 2           |
| 1.1 Old CEM versus New LonCEM                               | 2           |
| 1.2 Other Required Compressor Safeties                      | 3           |
| 2.0 Bill of Materials                                       | 3           |
| 3.0 Installation Instructions                               | 4           |
| 3.1 Mounting Module   | 4           |
| 3.2 Sensor Inputs   | 5           |
| 3.3 Control Outputs   | 7           |
| 3.4 Special Instructions For 05T Installations              | 9           |
| 3.5 LonWorks® Communication/Control Summary                 | 9           |
| 3.6 Troubleshooting/Application Notes                       | 11          |
| Appendix A - Functional Overview                            | 12          |
| Appendix B - Wiring Schematic                               | 13          |
| Appendix C – Sensor Wire Grounding                          | 14          |
| Appendix D - Alarm Summary                                  | 15          |
| Appendix E - Converting Sensor Outputs to Engineering Units | 17          |

## 1.0 Overview

The LonCEM is a solid state electronic module used as the primary compressor protection for our 74mm screw compressors. It is used on both our semi-hermetic (06T) and open-drive (05T) air conditioning and refrigeration compressors. Special instructions for 05T installations are provided in Section 3.4. The module provides thermal compressor protection by monitoring motor and discharge temperature and providing liquid injection cooling as required. Oil pressure protection is provided by monitoring suction, discharge and oil pressure. Pressure drop through the oil system (oil filters, oil cooler, oil line solenoid etc.) is continuously monitored to insure proper oil flow. Other features include reverse rotation protection, 20 second time-delay between compressor starts, volume index control for refrigeration models, and startup sequencing of the oil and economizer solenoid valves. A functional overview providing details on each module function is presented in Appendix A.

A LonWorks<sup>®</sup> version of the module is available, allowing communication over a LonWorks<sup>®</sup> control network. Through the network, the module can be instructed to provide on/off and unloading control. In addition, all module inputs including: suction pressure, discharge pressure, oil pressure, motor temperature, and discharge temperature are available for data logging and/or as input to another controller.

The module will be available as part of a package including all necessary sensors, wiring harnesses, and fittings. The remainder of this document provides a comparison of the old and new protection modules, bill of materials of the LonCEM module packages, installation instructions, trouble shooting and application notes, and a description of the sensor inputs and control outputs. Appendix E summarizes the conversion of the sensor outputs to engineering units, which is helpful when diagnosing sensor and operational problems.

### 1.1 Old CEM versus New LonCEM

The new LonCEM Packages (see section 2.0 for Bill of Materials) replace the older style CEM (P/N 3TA0796B). The newer style module incorporates 3 pressure transducers (in addition to the motor and discharge thermistor inputs used on the old module), which eliminate many of the previously required electro-mechanical pressure switches. The following items are no longer required when using the new LonCEM packages:

| <b>Description</b>             | <b>P/N</b> |
|--------------------------------|------------|
| Older Style CEM                | 3TA0796B   |
| Oil Pressure Protection Switch | HK06ZB006  |
| Reverse Rotation Switch        | HK01CB002  |
| Oil Filter Protection Switch   | HK06CA051  |
| 5k Thermistor*                 | HH79NZ065  |
| Electronic Phase Monitor**     | P251-0090  |

\* Still required, but is included in LonCEM package (see section 2 for complete BoM)

\*\* Was never required but offered as an option for reverse rotation protection.

## 1.2 Other Required System Safeties

The new (or old) **module does not eliminate the need for the Low and/or High Pressure safety switch(es)**. These functions are not included in the module.

A voltage sensing relay with normally open contacts should be wired to the load side of the compressor circuit breaker, with the contacts in series with the mechanical safeties as supplied to the Slimits input on the module. This is to deactivate the module (i.e. shut off oil feed) in case of a breaker trip.

## 2.0 Bill of Materials

To simplify installation, all of the required parts are included in a single package. Separate packages were developed for modules with and without the LonWorks® communication option. The following table lists all the components supplied in each package.

Table 1. Bill of Materials

| Item | OTA1063 Package with LonWorks (Quantity) | OTA1064 Package without LonWorks (Quantity) | Carlyle P/N   | Description   |
|------|--|---|---------------|---|
| 1    | 1  |   | 3TA1061       | LonCEM ( <b>with LonWorks</b> Transciever)                    |
| 1    |  | 1   | 3TA1062       | LonCEM ( <b>without LonWorks</b> Transciever)                 |
| 2    | 1  | 1   | HK05YZ003     | Low Pressure Transducer (suction)                             |
| 3    | 2  | 2   | HK05YZ002     | High Pressure Transducer (disch and oil)                      |
| 4    | 3  | 3   | 06TA680007S** | Harness for Transducers (15 ft lead wire)                     |
| 5    | 1  | 1   | HH79NZ065     | Discharge Temperature Thermistor (5 Kohm)                     |
| 6    | 1  | 1   | DD08SA051     | SAE Discharge Adapter Fitting (1.3"L, 7/16"-20 SAE to ¼" NPT) |
| 7    | 1  | 1   | DD08SA052     | SAE Suction Adapter Fitting (3.7"L, 7/16"-20 SAE to ¼" NPT)   |
| 8    | 2  | 2   | DD17GA051*    | Cross Fitting (suction and discharge)                         |

\* Parker Part Number: AVC1-4

\*\* Updated package includes shielded cable for the pressure transducer wiring harness, see Appendix C for proper shielded cable grounding techniques.

## 3.0 Installation Instructions

The following instructions cover mounting the module in the control panel, installing the sensor inputs on the compressor, and a description of the control outputs. A complete wiring diagram is contained in Appendix B which covers the control wiring and the wiring connections to the module.

### 3.1 Mounting Module

The module should be mounted in a protective environment (typically installed inside the unit electrical control box). Phoenix style screw-down connectors are supplied for all sensor inputs. The transducer harness assembly (Item 4) is equipped with 15 ft of shielded cable, used to connect the pressure transducers to the module. The red wire connects to the **+5** input, the white wire connects to the **Sig** input, and the black wire connects to the **Gnd** input. The remaining six inputs are for the motor temperature thermistor, discharge temperature thermistor, and communications input, all of which are polarity insensitive. Male quick disconnects are provided for all of the power inputs and control outputs.

#### *Grounding Shielded Cable*

In order to protect the module from the influence of electrical noise coupled onto the sensor input wires, it is recommended that shielded cable be used **for all of the sensor inputs**. The original pressure transducer wiring harness, which consisted of individual stranded wires, has been replaced with a shielded cable to aid in this effort. See Appendix C for a description of proper shielded cable grounding techniques.

## 3.2 Sensor Inputs

### *Suction Pressure (see Figure 1)*

1. Install the suction adapter fitting (Item 7) into the compressor's low side port (torque to 10-12 ft. lb, 14-16 NM).
2. Install the cross fitting (Item 8) into the adapter fitting (torque to 20-25 ft lb, 27-34 NM) using Teflon tape or pipe dope. The cross fitting can be oriented as desired.
3. The suction pressure transducer and low pressure switch are connected to the cross fitting. The schraeder port is available for field gauge connections.

The **suction** pressure transducer (Item 2) can be identified by a **blue dot** located on the black base of the transducer. The oil pressure and discharge pressure transducers (Item 3) do not contain any special markings on the black base.

### *Discharge Pressure (see Figure 1)*

1. Install the discharge adapter fitting (Item 6) into the compressor's high side port.
2. Install the cross fitting (Item 8) into the adapter fitting (torque to 20-25 ft lb, 27-34 NM) using Teflon tape or pipe dope. The cross fitting can be oriented as desired.
3. The discharge pressure transducer<sup>1</sup> (has no color dot identifier) and high pressure switch are connected to the cross fitting. The schraeder port is available for field gauge connections.

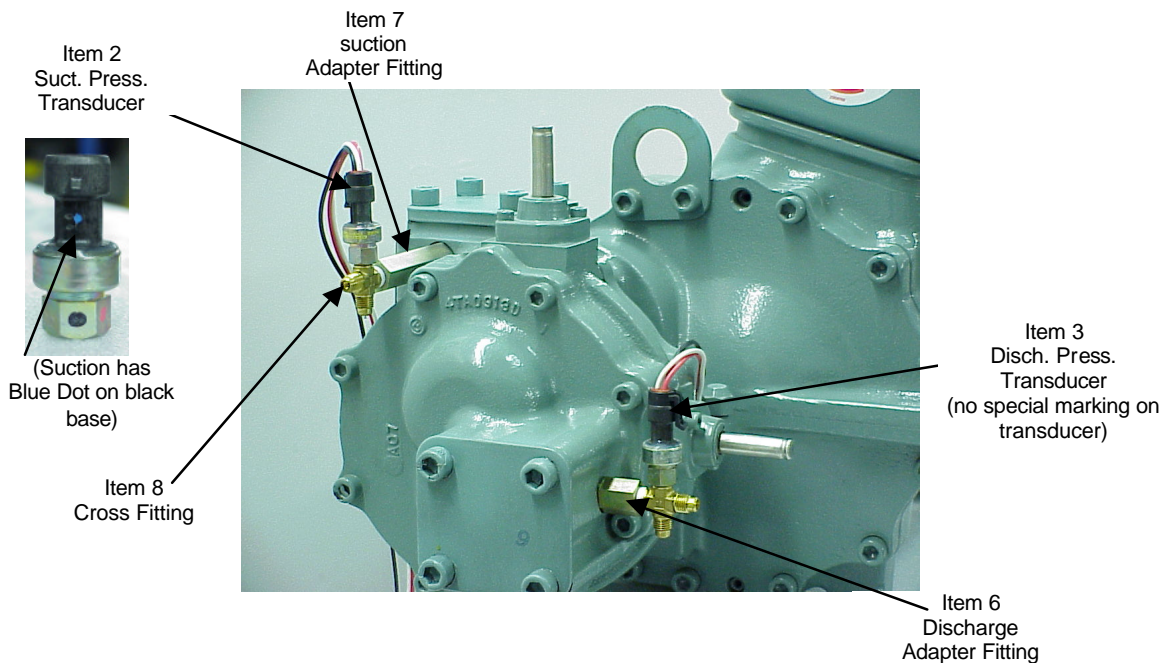

**Figure 1. Suction and Discharge Fittings**

<sup>1</sup> The same model pressure transducer is used to measure discharge and oil pressure.



## Oil Pressure

Figure 2 shows the compressor oil connections.

1. The oil pressure transducer is connected at the bottom of the oil solenoid sight glass assembly (optional assembly shown in main diagram) or alternatively at the top of the oil Tee fitting supplied on the compressor (shown in the exploded view to the upper left of main diagram).

The oil solenoid sight glass assembly shown in Figure 2 is an optional item (P/N EF12ZZ025), which can be purchased directly from Carlyle. The standard Oil Tee fitting supplied on the compressor is also shown.

2. One of the compressor schraeder fittings (removed from either suction or discharge access ports) should be installed at the end of the oil galley for oil pressure field measurements.

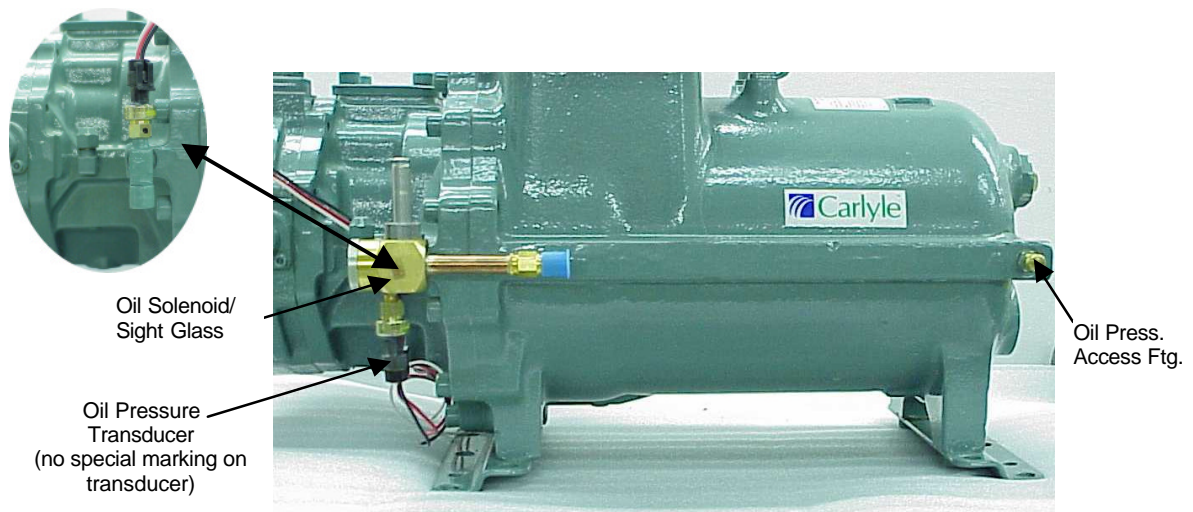

**Figure 2. Oil Fittings**

## Discharge Temperature

The discharge temperature sensor (Item 5) should be strapped to the discharge line as close to the discharge service valve as possible (within 6" or less is optimal). Carlyle recommends using thermoconductive grease to help insure accurate temperature readings. The thermistor must then be wrapped with high temperature insulation such as high temperature foam or cork insulation.

## Motor Temperature

A 5 Kohm thermistor is embedded within the motor windings, and is located between S1 and S2 on the compressor electrical terminal plate. Leads should be extended from the

terminal plate to the motor temperature inputs on the LonCEM module. In the event of a thermistor failure, a spare thermistor is available between S2 and S3.

### *Sensor Operating Range*

The table shown below shows the allowable operating range for each of the sensor inputs. Values measured outside these limits will result in a sensor failure alarm. See Appendix D for a summary of the sensor alarm codes. The inputs are verified both when the compressor is on and off.

| <b>Sensor Inputs</b>          | <b>Input Range</b> |             | <b>Corresponding Signal Range</b> |             |
|-------------------------------|--------------------|-------------|-----------------------------------|-------------|
|                               | <b>Low</b>         | <b>High</b> | <b>Low</b>                        | <b>High</b> |
| Suction Pressure Transducer   | -13.2 psig         | 140 psig    | 0.1 VDC                           | 4.74 VDC    |
| Discharge Pressure Transducer | -6.6 psig          | 450 psig    | 0.4 VDC                           | 4.9 VDC     |
| Oil Pressure Transducer       | -6.6 psig          | 450 psig    | 0.4 VDC                           | 4.9 VDC     |
| Motor Temp Thermistor         | -32°F              | 312°F       | 88,480 Ohms                       | 195 Ohms    |
| Discharge Temp Thermistor     | -32°F              | 312°F       | 88,480 Ohms                       | 195 Ohms    |

### **3.3 Control Outputs**

Each of the module outputs is summarized below. Note that each of the corresponding liquid LED lights (one for each output) is lit whenever the output is closed and the output is energized. See Table 2 for a summary of the module temperature control functions.

#### **1CR** *Contactor*

This terminal supplies power to the compressor contactor coil/relay. The module uses this output to turn the compressor on or off. Whenever power is supplied to Ccall (compressor call input), 1CR is closed pulling in the contactor and starting the compressor. A 20 second time delay between compressor starts is built into the module. The time delay is active at initial module power-up, or whenever the compressor is called for before 20 seconds of off-time has elapsed.

#### **2CR** *Part Wind Contactor*

Supplies power to the compressor part-wind contactor coil/relay, if part-wind start is used. This output is automatically energized 1 second after 1CR during start-up.

#### **Liq M** *Liquid Injection (initialized for Motor Cooling)*

Energized whenever the motor temperature limit is exceeded (see Table 2). This output is closed energizing the motor cooling valve and injecting liquid refrigerant into the motor compartment.

#### **Liq D** *Liquid Injection (initialized for Discharge Temperature)*

Carlyle Compressor Div.

P O Box 4808

Syracuse, NY 13221

Phone: 800-462-2759

Fax: 315-432-3274

Energized whenever the discharge temperature limit is exceeded (see Table 2). Typically the LiqM and LiqD outputs are wired in parallel with the motor cooling valve. Thus, the motor cooling valve is energized whenever the motor or discharge temperature limits are exceeded (see Appendix B for wiring schematic).

Optionally this output could energize a separate liquid injection valve for discharge temperature control, injecting liquid refrigerant directly into the rotors for discharge temperature control. Typically, a temperature activated liquid injection valve (strapped to discharge line) is used for discharge temperature control.

See the Screw Compressor Application Guide for supplemental (in addition to motor cooling valve) liquid injection requirements.

**Table 2. Temperature Control Limits**

|                       | Injection<br>On<br>°F (°C) | Injection<br>Off<br>°F (°C) | Shutdown<br>Temp<br>°F (°C) | Reset<br>Temp<br>°F (°C) |
|-----------------------|----------------------------|-----------------------------|-----------------------------|--------------------------|
| Discharge Temperature | 205 (96)                   | 190 (88)                    | 230 (110)                   | 200 (93)                 |
| Motor Temperature     | 180 (82)                   | 165 (74)                    | 240 (116)                   | 200 (93)                 |
| Unloading (Motor)     | N/A                        | N/A                         | 220 (104)                   | 205 (96)                 |

**UNL** *Unloader Coil Output*

All 05T and 06T screw compressors are supplied with one step of unloading. Control of the unloading function is not accomplished by the module, but is controlled externally by a rack controller or pressure switch wired in series with the UNL output. The module has a 30 second time delay before energizing the unloader output, insuring the compressor starts unloaded. The compressor is loaded when the unloading coil is energized.

**OIL** *Oil and Economizer Solenoid Output*

Energized during compressor operation and is de-energized when it is shut off. The oil line and economizer line solenoid valves should be connected in parallel to this output as they are also sequenced on compressor Start/Stop.

It is critical that oil be supplied to the compressor whenever it is running and not supplied when it is off. Similar concerns exist regarding the flow of refrigerant through the economizer line. This output insures this functionality.

**VI** *VI Coil Output*

All **refrigeration duty** 05TR and 06TR screw compressors are supplied with VI control. The Vi valve (stem located at the 3 o'clock position on the outlet casing) controls the point at which refrigerant exits the rotors. The Vi valve is energized (hi Vi) when the compression ratio is above 5:1, and de-energized (low-Vi) when the compression ratio drops below 5:1. The module continuously monitors the operating pressure ratio and

controls the Vi output accordingly. The Vi control effects compressor power only and has no effect on compressor capacity. It is controlled for optimal compressor efficiency.

The module has a 30 second time delay before controlling the Vi output. This insures that the compressor starts in the low Vi (solenoid de-energized) setting.

05TA & 06TA air conditioning screw compressors do not have a Vi valve.

### ***ALM Alarm Output***

Energized whenever the module enters an alarm state (compressor may or may not be operating depending on the severity of the alarm). The coded alarm light (amber) on the module is flashed at the respective rate in order to indicate the compressor alarm. The flashing is repeated after a short pause. Each of the sensor failure alarms is preceded by a long dash. A comprehensive explanation of the alarm states, including the operational criteria and which alarms require a power reset to clear, is presented in Appendix D.

### **3.4 Special Instructions for 05T Installations**

The only module application differences between 05T and 06T compressors are:

1. Since the 5K motor thermistor is not available for the open drive 05T compressors, a 5.1Kohm resistor (simulating a 76 F temperature reading) should be placed across the motor temperature input. Any ¼ watt carbon film 5.1 Kohm +/-5% resistor, available from many electronic part stores, is acceptable.
2. The oil pressure access fitting on the 06T compressor is not available on the 05T compressors. Therefore, a T-fitting should be supplied at the oil pressure transducer fitting for field gauge readings.

### **3.5 LonWorks® Communication/Control Summary**

Modules are available with and without the LonWorks® communications (see section 2). LonWorks® modules include an FTT10A transceiver allowing them to be connected to other devices over a LonWorks® control network. This allows additional control functionality as well as access to sensor input values and memory storage. A detailed summary of the network variables is included in the “LonCEM Network Interface Notes” document available from Carlyle Application Engineering. Additional information on LonWorks® can be found at [www.echelon.com](http://www.echelon.com). Following is an overview of the LonWorks® Communication / Control functions:

#### **Additional Control Functions**

- Compressor ON/OFF Control
- Compressor Unloader Control
- Module Reset

#### **Available Inputs**

All of the modules sensor inputs can be polled over the network including:

Carlyle Compressor Div.

P O Box 4808

Syracuse, NY 13221

Phone: 800-462-2759

Fax: 315-432-3274

- Suction Pressure
- Discharge Pressure
- Oil Pressure
- Motor Temperature
- Discharge Temperature

#### Memory Storage

The following information is stored in the modules permanent memory.

- All sensor readings recorded prior to the last compressor alarm
- Number of Compressor Cycles
- Compressor Run-Time
- Cumulative Alarm Trips for each Compressor Alarm

## 3.6 Troubleshooting / Application Notes

### 3.6.1 *Electrical Noise*

As with any electronic device that contains a microprocessor, operation of the module can be effected by electrical noise on any of the input wires (power or sensor) or even the power output wiring. Below are wiring recommendations that should be followed for all installations. Special attention should be made on installations where a variable frequency (inverter) drive is used.

The sensor input wires should never run adjacent (in free air or in conduit) to high voltage wiring. Electromagnetic and capacitive coupling from high voltage wiring to the sensor wires can corrupt the sensor readings possibly resulting in operational problems. The module and all module wiring should be kept away from high voltage components such as power transformers, relays, contactors, etc.

If an inverter is used, precautions should be made to insure that the wires to or from the module are not closely coupled with inverter power wiring, especially the wiring from the inverter to the compressor motor. Inverters can emit a significant amount of electrical noise, which is normal on the output side of the inverter (between inverter and motor).

### 3.6.2 *Pressure Transducer Readings*

The cross fitting supplied in the LonCEM package (see Item 8 in Figure 1) for the suction and discharge access fittings, is supplied with one schraeder fitting (intended for field gauge measurements). We do not recommend adding a schraeder fitting to any of the pressure transducer fittings. However, if a schraeder valve is used, precautions should be made to insure that the schraeder valve is fully engaged. A partially engaged schraeder valve can lead to false pressure readings.

### 3.6.2 *Service LED Lamp*

The service lamp (red LED located in lower right hand corner of module) is used in conjunction with the LonWorks<sup>®</sup> network (i.e. will light when being installed as a node on the network). If blinks while the module is installed on a network try re-installing the module on the network. If it is lit steady during module operation this indicates that the module software is not functioning properly. This most likely indicates a hardware problem with the module and it should be replaced.

## Appendix A - Functional Overview

### LonCEM FUNCTIONAL LOGIC

#### START-UP SEQUENCE

- A 20 second time delay between compressor starts is built into the module. The time delay is active at initial module power-up, or whenever the compressor is called for before 20 seconds of off-time has elapsed.
- CEM supplies power to the contactor and Oil Solenoid
- 1.25 seconds after startup, the CEM checks for reverse rotation
- 30 seconds after startup, compressor is loaded
- 30 seconds after startup, safeties and VI control begins
- 180 seconds after startup, CEM begins to monitor oil system pressure drop

#### MOTOR COOLING CONTROL

- The motor cooling valve will be energized when the motor temperature reaches 180F and will de-energize when the temperature drops below 165F
- When the motor temperature reaches 220F the CEM will unload the compressor until the temperature drops below 205F
- If the motor temperature reaches 240F the CEM will shut off the compressor until the temperature drops below 200F

#### INPUT DEVICE FAILURES

- The module will shut off the compressor if it detects any failure of an input device (thermistors, pressure transducers)

#### DISCHARGE TEMPERATURE CONTROL

- The motor cooling valve will be energized when the discharge temperature reaches 205F and will de-energize when the temperature drops below 190F
- If the discharge temperature reaches 230F the CEM will shut off the compressor until the temperature drops below 200F

#### OIL PRESSURE DIFFERENTIAL PROTECTION

- If the pressure differential between oil and suction drops below 45 psi for 90 continuous seconds, the compressor will be shut off

#### OIL SYSTEM PRESSURE DROP SAFETY

- If the pressure differential between discharge and oil increases to 35 psi for 15 continuous seconds an alarm code will flash
- If the pressure differential between the discharge and oil increases to 50 psi for 15 continuous seconds the compressor will be shut off

#### VI CONTROL

- The VI coil is energized when the pressure ratio is greater than 4.9:1 and will de-energize when the pressure ratio drops below 5.1:1

# Carlyle LonCEM

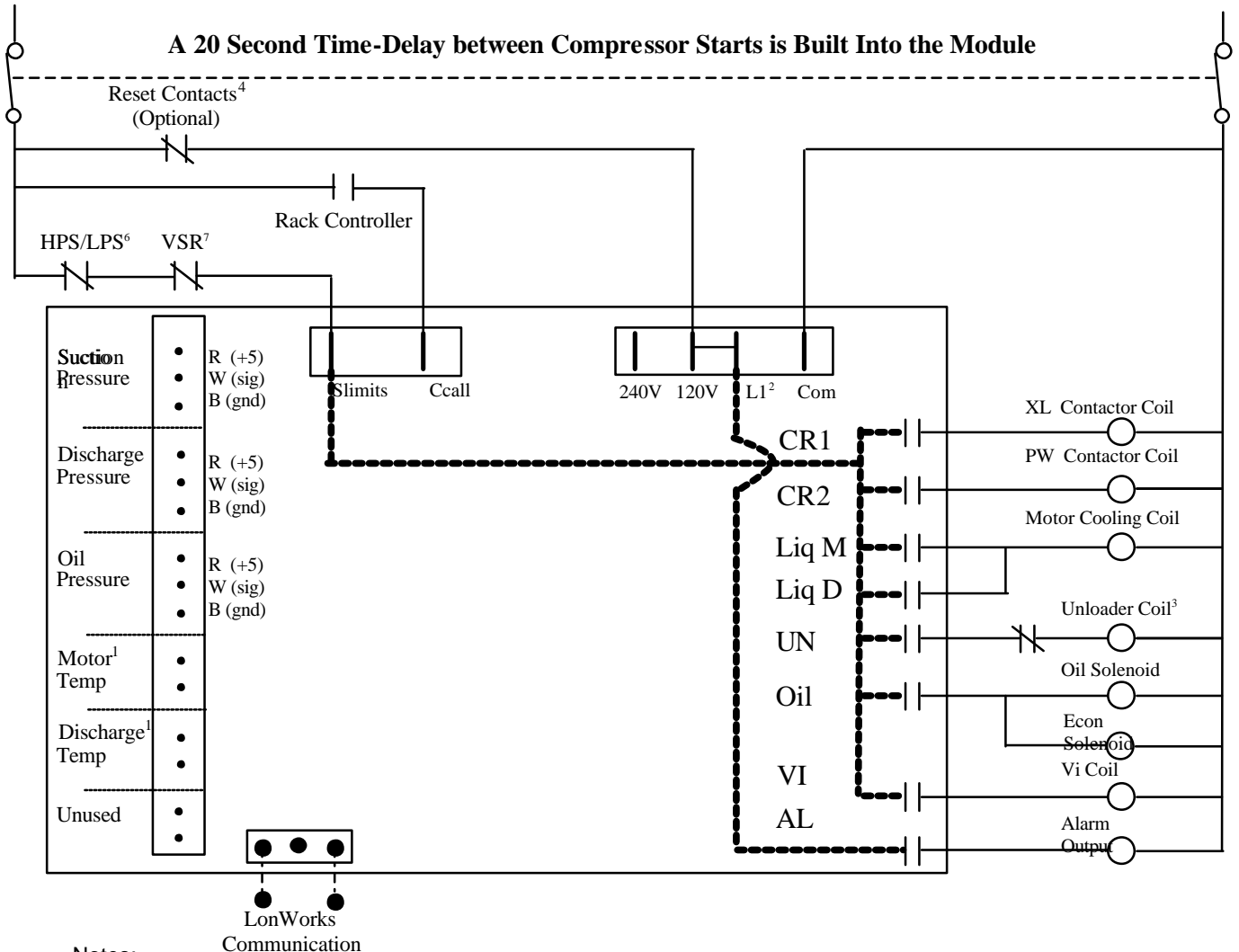

**Notes:**

1. Connections for Motor Temp, Discharge Temp, and echelon communications are all polarity insensitive.
2. L1 must be jumpered to 240V or 120V depending on line voltage. The drawing shows wiring for 120V. The L1 input is used to power the alarm output.
3. The compressor is *loaded* when the solenoid is energized and *unloaded* when de-energized.
4. A normally closed set of contacts can be added to reset power to the module. Useful for remotely resetting a module out on an Alarm Failure
5. The diagnostic alarm code is flashed by the yellow alarm light during a compressor alarm.
6. The system safeties are monitored on the Slimits Input. This input actually powers the contactor output and is switched through the module. See section 1.2 for details on the additional required system safeties.
7. A voltage sensing relay (VSR) (or an equivalent method) should be used to detect if power is lost to the line side of the contactor (i.e. circuit breaker has tripped).



## Appendix C – Sensor Wire Grounding

In order to avoid electrical noise on the signal input wires it is important to use shielded cable (pressure transducer harnesses included in the module package are shielded) for all of the pressure and temperature sensor inputs, and to properly ground them as discussed below.

The picture below shows the wiring for the 3 wire pressure transducers. The same procedure should be used with the 2 wire temperature inputs with the drain wire being wrapped around the ground wire, which is the bottom wire for the temperature inputs.

Drain wire - should be wrapped around the ground wire and inserted into the signal ground input (see right)

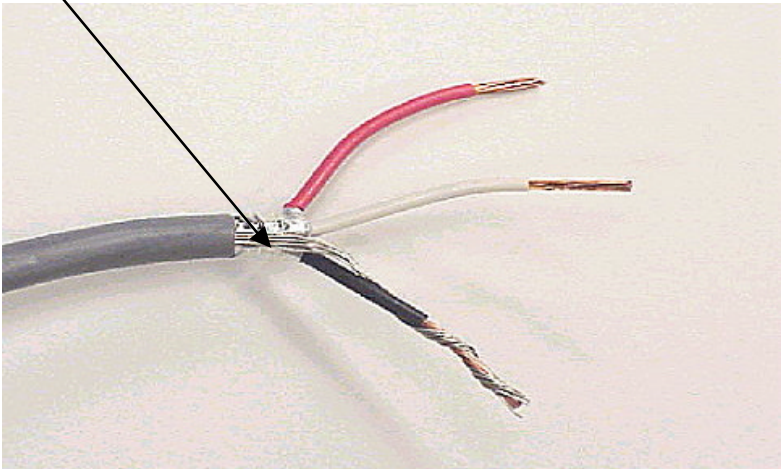

Pins: 3, 6, 9, 11, 13 and 15 (counting from the top) are all **Ground Inputs**

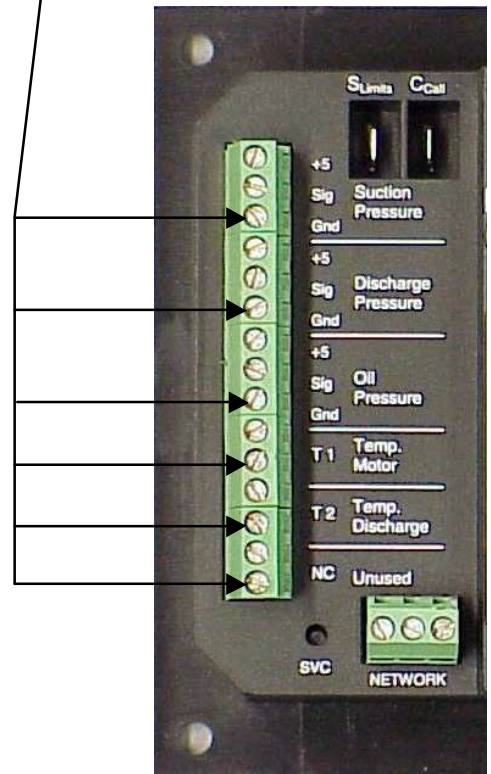

### Additional Notes

1. Each sensor (pressure transducers and thermistors) should be run in separate shielded cables, with the drain wire wrapped around the ground\* wire and both connected to the ground input.
2. The shielded cable drain wire should **only** be connected at the module end (i.e. not grounded at the sensor end).

\* The ground wire is the black wire for the pressure transducer's and is whatever wire is connected to the ground input (bottom input) for the thermistors.

## Appendix D - Alarm Summary

| ALARM   | Alarm Code | Manual Reset |
|---|------------|--------------|
| <p><b>Reverse Rotation</b><br/>           If at any point between 1.25 and 15 seconds after startup a decrease in the discharge pressure of over 10 psig is detected, a shutdown sequence<sup>2</sup> is initiated. Reverse rotation is only checked during the first 15 seconds of compressor operation.</p> <p>Pd1 – Pd2 &gt; 10 psig, where Pd2 is recorded 1.25 sec after Pd1</p> | 1          | Yes          |
| <p><b>Safety Circuit Open</b><br/>           If at any point the line connecting the Slimits input to L1 is broken (i.e. one of the safeties trips), the compressor is shut down and this alarm code is flashed.</p>  | 2          | No           |
| <p><b>Oil System Pressure Drop</b><br/>           If the pressure drop across the oil system is greater than 35 psig for more than 15 seconds, this alarm code is flashed.</p> <p>Pd – Po &gt; 35 psig for 15 continuous seconds</p>  | 3          | No           |
| <p>If the pressure drop across the oil system is greater than 50 psig for more than 15 seconds, a shutdown sequence is initiated.</p> <p>Pd – Po &gt; 50 psig for 15 continuous seconds</p>   | 3          | Yes          |
| <p><b>Oil Pressure Differential</b><br/>           If the difference between oil pressure and suction pressure is less than 45 psig for more than 90 seconds, a shutdown sequence is initiated.</p> <p>Po – Ps &lt; 45 psig for 90 continuous seconds</p>   | 4          | Yes          |
| <p><b>Discharge Temperature</b><br/>           If the discharge temperature rises above 230F, a shutdown sequence is initiated. Once the discharge temperature drops below 200F for 30 continuous seconds the module will automatically reset.</p>  | 5          | No           |
| <p><b>Motor Temperature</b><br/>           If the motor temperature rises above 220F, the unloader is de-energized and this alarm code is flashed until the temperature drops to 205F.</p>  | 7          | No           |
| <p>If the motor temperature rises above 240F, a shutdown sequence is initiated. Once the motor temperature drops below 200F for 30 continuous seconds</p>   | 6          | No           |

<sup>2</sup> All outputs are de-energized (except for alarm) and the appropriate alarm code is flashed.  
 Carlyle Compressor Div. P O Box 4808 Syracuse, NY 13221  
 Phone: 800-462-2759 Fax: 315-432-3274

the module will automatically reset.

## ALARM

**Alarm Code    Manual Reset**

### Sensor Failure

If at any point the module detects a failure of an input device (thermistor, pressure transducer), the module will initiate a shutdown sequence.

|                                     |     |    |
|-------------------------------------|-----|----|
| Motor Thermistor Failure            | 1-1 | No |
| Discharge Thermistor Failure        | 1-2 | No |
| Suction Pressure Transducer Failure | 1-3 | No |
| Oil Pressure Sensor Failure         | 1-4 | No |
| Discharge Pressure Sensor Failure   | 1-5 | No |

## Alarm Code Summary

Following is a summary of the diagnostic alarm codes flashed by the yellow alarm light during a compressor alarm.

| <b>DIAGNOSTIC CODES</b>  |                                |
|--|--------------------------------|
| <b>CODE</b>  | <b>Definition</b>              |
| 1  | Reverse Rotation               |
| 2  | Safety Circuit Open            |
| 3  | Change Oil Filter              |
| 4  | Low Oil Differential           |
| 5  | High Discharge Temperature     |
| 6  | High Motor Temperature         |
| 7  | Compressor Unloading           |
| 1-1  | Motor Thermistor Failure       |
| 1-2  | Discharge Thermistor Failure   |
| 1-3  | Suction Press Sensor Failure   |
| 1-4  | Oil Pressure Sensor Failure    |
| 1-5  | Discharge Press Sensor Failure |
| <b>Notes:</b>  |                                |
| - The alarm code is flashed out by the amber alarm lamp  |                                |
| - A pause is present after each code is flashed out  |                                |
| - The sensor failure codes (1-1:1-5) are preceded by a long steady lamp to distinguish them from the other alarm codes |                                |

## Appendix E - Converting Sensor Inputs to Engineering Units

### Pressure Transducers

The following graphs show the sensor output voltage, as measured across the **Sig** and **Gnd** terminals, versus the operating pressure. Separate graphs are shown for the low side (suction) and high side (discharge and oil) transducers. The equations shown in the graphs give approximate values as they assume a perfect +5 power supply.

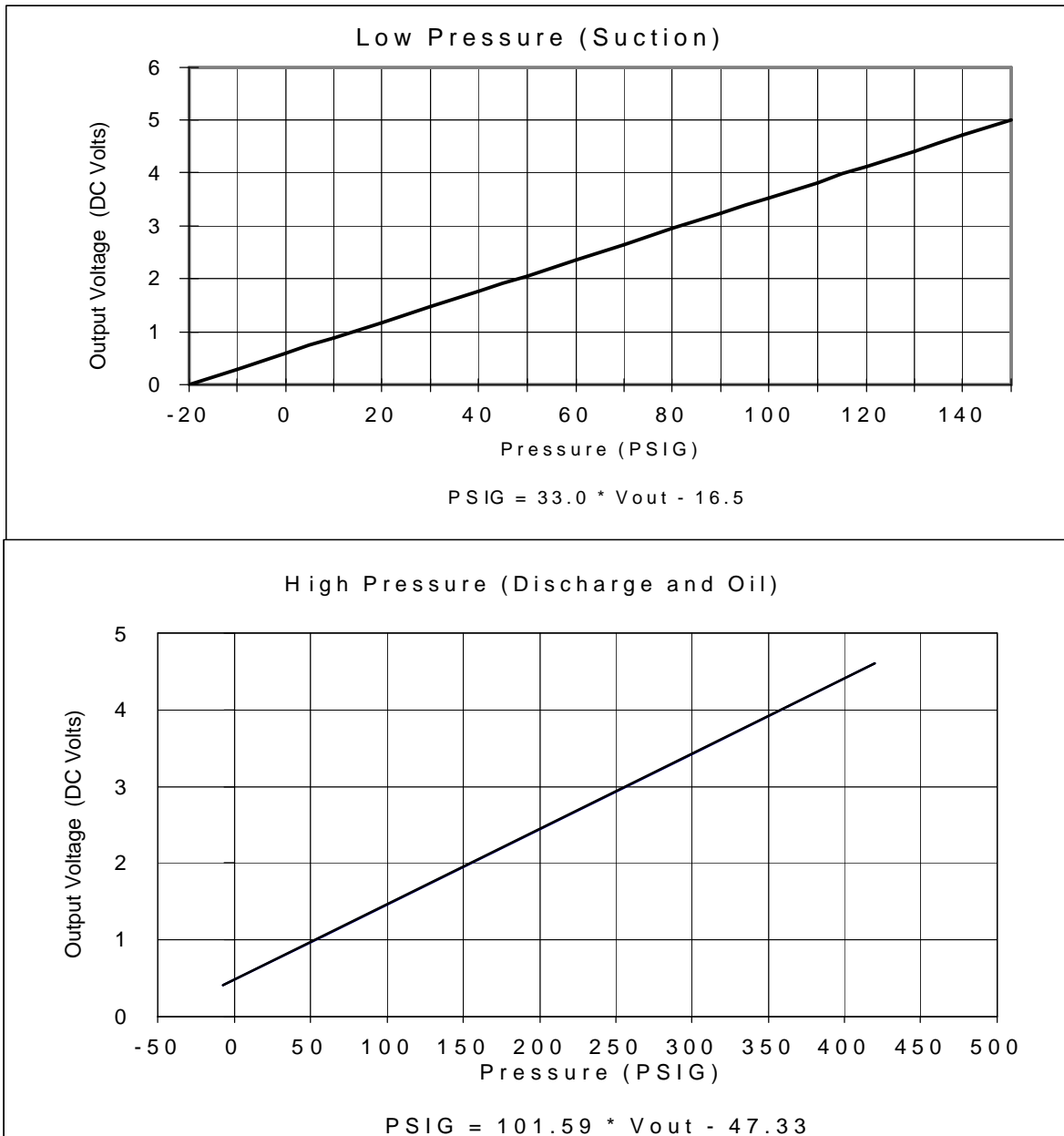

## Motor and Discharge Thermistors

The following table shows conversion of module voltage (as measured across the modules input terminals) and thermistor resistance (as measured across the thermistor leads when not connected to the module) to temperature.

### LonCEM 5K Thermistor Output Conversion to Temperature

| Voltage <sup>1</sup><br>(VDC) | Resistance <sup>2</sup><br>(ohms) | Temp<br>(C) | Temp<br>(F) | Voltage <sup>1</sup><br>(VDC) | Resistance <sup>2</sup><br>(ohms) | Temp<br>(C) | Temp<br>(F) |
|-------------------------------|-----------------------------------|-------------|-------------|-------------------------------|-----------------------------------|-------------|-------------|
| 4                             | 6480.0                            | 19.2        | 66.5        | 2.1                           | 1173.1                            | 61.6        | 142.9       |
| 3.9                           | 5743.6                            | 21.9        | 71.4        | 2                             | 1080.0                            | 64.0        | 147.1       |
| 3.8                           | 5130.0                            | 24.4        | 75.9        | 1.9                           | 992.9                             | 66.4        | 151.4       |
| 3.7                           | 4610.8                            | 26.9        | 80.3        | 1.8                           | 911.2                             | 68.8        | 155.9       |
| 3.6                           | 4165.7                            | 29.2        | 84.6        | 1.7                           | 834.5                             | 71.4        | 160.6       |
| 3.5                           | 3780.0                            | 31.5        | 88.7        | 1.6                           | 762.4                             | 74.1        | 165.4       |
| 3.4                           | 3442.5                            | 33.7        | 92.7        | 1.5                           | 694.3                             | 76.9        | 170.5       |
| 3.3                           | 3144.7                            | 35.9        | 96.6        | 1.4                           | 630.0                             | 79.9        | 175.8       |
| 3.2                           | 2880.0                            | 38.1        | 100.5       | 1.3                           | 569.2                             | 83.1        | 181.5       |
| 3.1                           | 2643.2                            | 40.2        | 104.3       | 1.2                           | 511.6                             | 86.4        | 187.6       |
| 3                             | 2430.0                            | 42.3        | 108.1       | 1.1                           | 456.9                             | 90.1        | 194.1       |
| 2.9                           | 2237.1                            | 44.4        | 111.9       | 1                             | 405.0                             | 94.0        | 201.3       |
| 2.8                           | 2061.8                            | 46.5        | 115.6       | 0.9                           | 355.6                             | 98.4        | 209.1       |
| 2.7                           | 1901.7                            | 48.6        | 119.4       | 0.8                           | 308.6                             | 103.3       | 217.9       |
| 2.6                           | 1755.0                            | 50.7        | 123.2       | 0.7                           | 263.7                             | 108.8       | 227.8       |
| 2.5                           | 1620.0                            | 52.8        | 127.0       | 0.6                           | 220.9                             | 115.2       | 239.4       |
| 2.4                           | 1495.4                            | 54.9        | 130.9       | 0.5                           | 180.0                             | 122.9       | 253.2       |
| 2.3                           | 1380.0                            | 57.1        | 134.8       | 0.4                           | 140.9                             | 132.5       | 270.4       |
| 2.2                           | 1272.9                            | 59.4        | 138.8       | 0.3                           | 103.4                             | 145.2       | 293.3       |

#### Notes

1. Voltage measured between thermistor input pins on module sensor terminal block.
2. Resistance measured across the Thermistor Leads when **not** connected to module.

# APPENDIX B

## Original Carlyle Electronic Module (CEM)

### Table of Contents

|  | <u>Page</u> |
|--|-------------|
| 1.0 Overview                               | 1           |
| 2.0 Carlyle Electronic Module (CEM) Device | 2           |
| 3.0 Oil System Schematics                  | 5           |
| 4.0 Refrigerant Management System          | 6           |

## **1.0 Overview – Original Carlyle Electronic Module (CEM)**

Previous sections of this application manual describe the installation and application of the LonCEM, which became available mid-2000. The LonCEM is an upgrade to and a replacement for the original Carlyle Electronic Module (CEM), P/N 3TA0796B, which was provided with 05T/06T screw compressor up to that date. For reference, a description of the installation and application of the original CEM is presented as an aid to service on existing systems.

The use of this module does not eliminate the need for the Low and/or High Pressure safety switch(es). The functions are not included in the module.

A voltage sensing relay with normally open contacts should be wired to the load side of the compressor circuit breaker, with the contacts in series with the mechanical safeties. This is to deactivate the module (i.e., shut off oil feed) in case of a breaker trip.

All systems manufactured after October 1998 and HFC systems manufactured prior to this date should incorporate the Carlyle HK06ZB006 mechanical oil safety switch. This switch monitors the differential between compressor discharge and oil inlet. It will shut down the compressor if the pressure differential is greater than 45 psi (3 bar). Systems incorporating R-22 prior to October 1998 may still incorporate the Carlyle HK06ZB001 mechanical oil safety switch. This switch monitors the pressure differential between compressor suction and oil inlet. The same mechanical oil safety switch is used for both oil protection systems. The HK06ZB006 mechanical oil safety switch is the only replacement switch available. It can easily be field modified to function as a HK06ZB001 switch by following instructions provided. When the HK06ZB001 switch is used the pressure differential must be monitored across the oil filters and the compressors shut down if the differential is greater than 45 psi (3 bar).

## 2.0 Carlyle Electronic Module (CEM)

The Carlyle solid-state electronic module (115v-1-50/60 or 240v-1-50/60) is used for primary control of the compressor contactor, oil and economizer line solenoids, and unloader and Vi coils. It also provides compressor thermal safety protection.

Temperature control for a screw compressor is critical. Excessive discharge gas and motor temperatures can cause premature compressor failures. Therefore control of these temperatures is very important. The CEM monitors these temperatures through the use of the factory-installed 5K thermistor in the motor windings and field-installed 5K thermistor on the discharge line. When either thermistor indicates an overheated condition, the CEM will energize a liquid injection valve, sending cool liquid into the motor compartment. This will lower the temperature to

an acceptable level. Should the thermistor continue to register an overheated condition, the CEM will shut down the compressor. **This liquid injection motor cooling valve (Carlyle P/N EF28BZ007) (used on all models), must be added to the economizer line downstream of the check valve and upstream of each compressor.**

Along with temperature monitoring, the module will control the startup sequencing of the unloader coil, Vi coil, oil line solenoid, and economizer solenoid.

The module has received several changes over time. The most recent version (AA2203-4) controls per the parameters listed in the table below. For information on previous versions, please contact Carlyle Application Engineering.

Refer to Section 8.6 for specific information on using the CEM with 05T compressors.

| CEM Version<br>AA2203-4 | Injection on<br>°F (°C) | Injection off<br>°F (°C) | Time Delay<br>Seconds | Shutdown Temp.<br>°F (°C) | Reset Temp.<br>°F (°C) | Reset Time Delay<br>Seconds |
|-------------------------|-------------------------|--------------------------|-----------------------|---------------------------|------------------------|-----------------------------|
| Discharge               | 205 (96)                | 190 (88)                 | 2                     | 230 (110)                 | 200 (93)               | 30                          |
| Motor                   | 180 (82)                | 165 (74)                 | 2                     | 240 (116)                 | 200 (93)               | 30                          |
| Unloading (motor)       | N/A                     | N/A                      | N/A                   | 220 (104)                 | 205 (96)               | N/A                         |

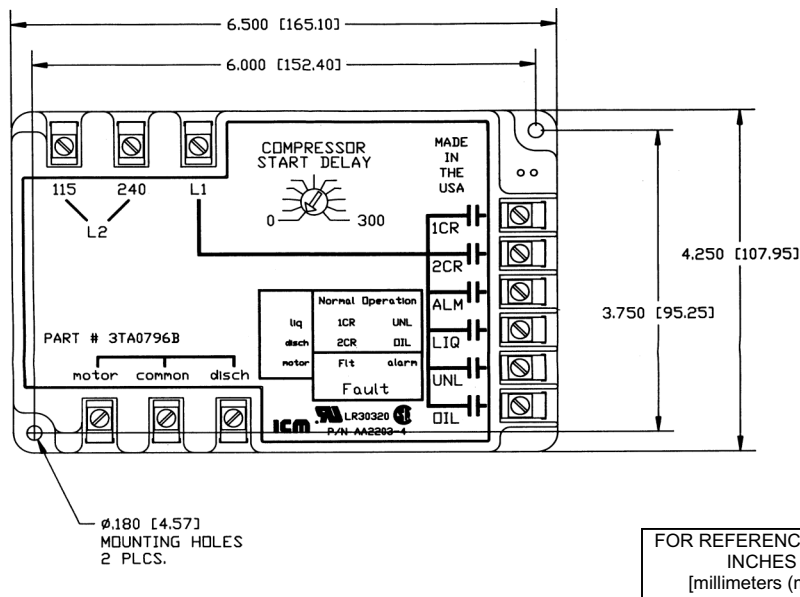

When a shutdown situation occurs due to a high motor or discharge temperature, 1CR, 2CR, LIQ, UNL, and OIL outputs will all open while the ALM output will close. The alarm LED will light along with the corresponding failure LED (motor or discharge). The module will reset when the motor or discharge reaches the reset temperature and a 30-second delay is observed.

The motor 5K thermistor is located between S1 and S2 on the compressor electrical terminal plate. In the event of a thermistor failure, a spare thermistor is available between S3 and S2. Attach S1 to the motor connection on the lower left of the CEM. Connect S2 to the common port just to the right of the motor connection on the CEM. The discharge 5K thermistor has two wires. Attach one wire to the discharge connection on the lower left of the CEM. The other wire should be connected to the same common port where the motor 5K thermistor is attached. The discharge 5K thermistor must be mounted on a clean dry area of the discharge line as close to the discharge service valve as possible. The thermistor must then be wrapped with high temperature insulation.

Should either 5K thermistor fail (open or short), the compressor will be shut down with 1CR, 2CR, LIQ, UNL, and OIL outputs all opening while the ALM output closes. The alarm LED will light along with the fault LED and the corresponding 5K thermistor LED (motor or discharge).

The DC voltage can be measured across the motor and, or discharge pins (motor to common or discharge to common) and converted to temperature. See the "Temperature vs. DC Voltage" on the following page for the conversion.

The connection where power is brought into the module is found at port L1 located at the upper left corner of the CEM. The module must be wired last in series with the other mechanical safeties (see CEM Wiring Diagram below). In order to complete the circuit for the module, L2 (common) must be wired to the 240 or 115 connection, depending on the control voltage. Detailed information on each CEM output is shown on next page.

### CEM WIRING DIAGRAM

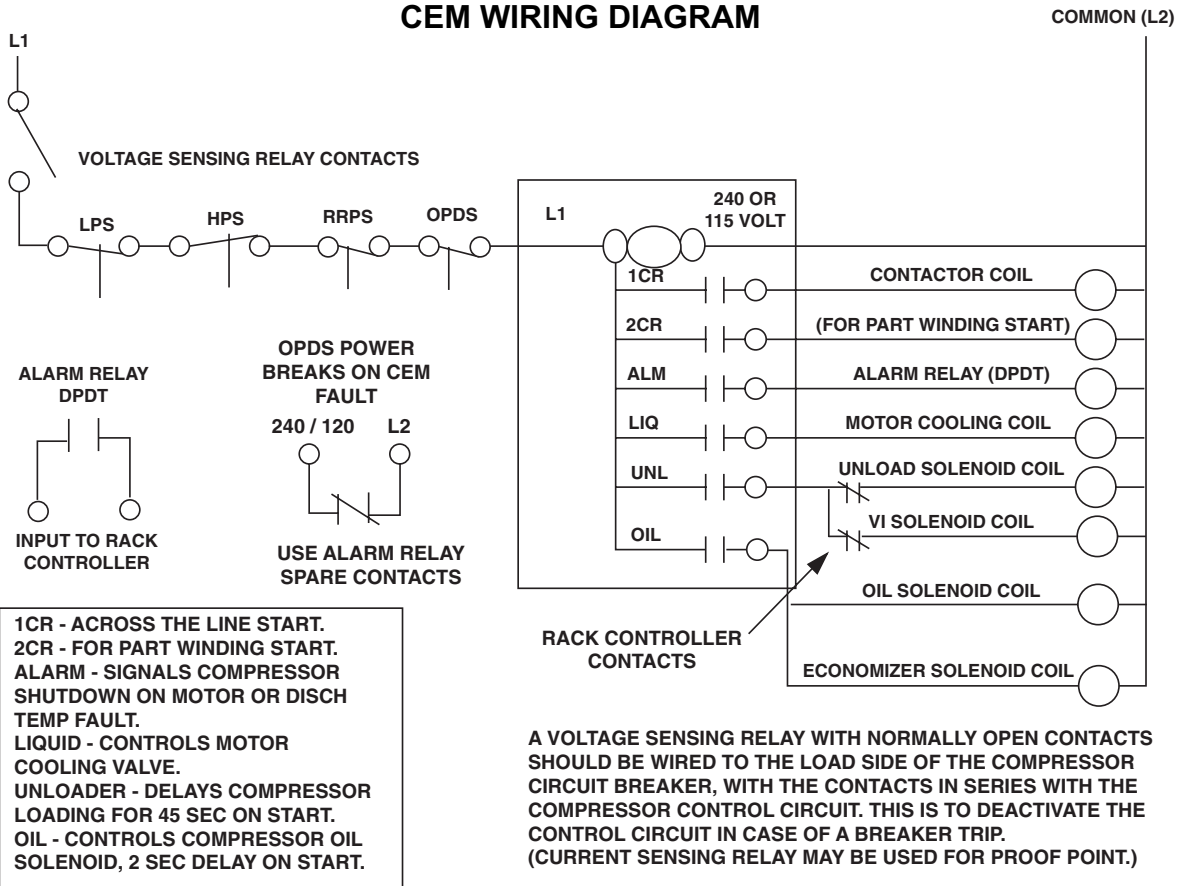



## TEMPERATURE VS. DC VOLTAGE

| Measured Voltage | Thermistor Resistance | Degrees Celsius | Degrees Fahrenheit |
|------------------|-----------------------|-----------------|--------------------|
| 3.6              | 2038 $\Omega$         | 46.80°C         | 116.24°F           |
| 3.5              | 1887 $\Omega$         | 48.80°C         | 119.84°F           |
| 3.4              | 1731 $\Omega$         | 51.05°C         | 123.89°F           |
| 3.3              | 1603 $\Omega$         | 53.10°C         | 127.58°F           |
| 3.2              | 1472 $\Omega$         | 55.40°C         | 131.72°F           |
| 3.1              | 1361 $\Omega$         | 57.50°C         | 135.50°F           |
| 3.0              | 1263 $\Omega$         | 59.60°C         | 139.28°F           |
| 2.9              | 1170 $\Omega$         | 61.70°C         | 143.06°F           |
| 2.8              | 1084 $\Omega$         | 63.85°C         | 146.73°F           |
| 2.7              | 1005 $\Omega$         | 66.05°C         | 150.89°F           |
| 2.6              | 929 $\Omega$          | 68.30°C         | 154.94°F           |
| 2.5              | 862 $\Omega$          | 70.45°C         | 158.81°F           |
| 2.4              | 794 $\Omega$          | 72.90°C         | 163.22°F           |
| 2.3              | 736 $\Omega$          | 75.20°C         | 167.36°F           |
| 2.2              | 683 $\Omega$          | 77.45°C         | 171.41°F           |
| 2.1              | 631 $\Omega$          | 79.85°C         | 175.73°F           |
| 2.0              | 581 $\Omega$          | 82.45°C         | 180.41°F           |
| 1.9              | 537 $\Omega$          | 84.90°C         | 184.82°F           |
| 1.8              | 494 $\Omega$          | 87.55°C         | 189.59°F           |
| 1.7              | 457 $\Omega$          | 90.10°C         | 194.18°F           |
| 1.6              | 419 $\Omega$          | 92.95°C         | 199.31°F           |
| 1.5              | 382 $\Omega$          | 96.00°C         | 204.80°F           |
| 1.4              | 347 $\Omega$          | 99.25°C         | 210.65°F           |
| 1.3              | 315 $\Omega$          | 102.60°C        | 216.68°F           |
| 1.2              | 284 $\Omega$          | 106.20°C        | 223.16°F           |
| 1.1              | 253 $\Omega$          | 110.35°C        | 230.59°F           |
| 1.0              | 225.5 $\Omega$        | 114.50°C        | 238.10°F           |

## **1CR**

Supplies power to the compressor contactor coil/relay. The output can supply 12 amps at 125 volts and 7 amps at 250 volts. The module uses this output to turn on and off the compressor when required. Whenever power is supplied to L1, 1CR is closed, pulling in the contactor and starting the compressor. The 1CR LED will light whenever the 1CR output is closed.

## **2CR**

Supplies power to the compressor part-wind contactor coil/relay if part-wind start is used. The output can supply 12 amps at 125 volts and 7 amps at 250 volts. This output is automatically energized 1.25 seconds after 1CR during start-up. The 2CR LED will light whenever the 2CR output is closed. If part-wind start is not used, connect the economizer line solenoid to this output.

## **UNL**

Each 05T and 06T screw compressor is supplied with 1 step of unloading. The unloader coil and Vi coil (if using an 05TR or 06TR compressor) are connected in parallel to this output. If the application calls for taking advantage of unloading the compressor, or operating at the low Vi setting, a rack controller or other controlling device must be used. Connect the signal from the rack controller or other controlling device in series between the CEM output and the unloader or Vi coil. The CEM has a built-in 45-second time delay between when 1CR is closed and the UNL output is closed. This allows the compressor to run for 45 seconds unloaded and with a low Vi on start-up which assists in creating a softer start. The UNL LED will light when the output is closed.

## **ALM**

Whenever a shutdown or fault condition occurs, power is supplied to this output and its corresponding LED lighted. The intention of this output is to allow a signal to be sent back to the rack controller or other signaling device, informing a person of the failure.

## **LIQ**

Supplies power to the motor cooling valve coil. Whenever the motor or discharge temperatures exceed their limits, this output is closed to inject liquid into the motor compartment. During this time the liquid LED is energized along with the corresponding motor or discharge LED. When the motor or discharge has cooled to an acceptable level, the output is opened.

## **OIL**

The oil line and the economizer line solenoids are connected in parallel at this output. If no part-wind start is used, connect the economizer line solenoid to the 2CR output. It is critical that oil be supplied to the compressor whenever it is running and not supplied when off. This output ensures that will happen. There is a 2-second time delay between when 1CR is closed and OIL is closed

## **TIME DELAY**

The CEM also has a built-in timer which will delay the start of the compressor anywhere between 0 and 300 seconds from when power is supplied to L1. This is useful with multiple compressors on a rack to prevent all compressors from starting at the same time.

# 3.0 Oil System Schematics Used with Older Carlyle Electronic Module (CEM) Systems

OIL SYSTEM SCHEMATIC  
ISOMETRIC VIEW

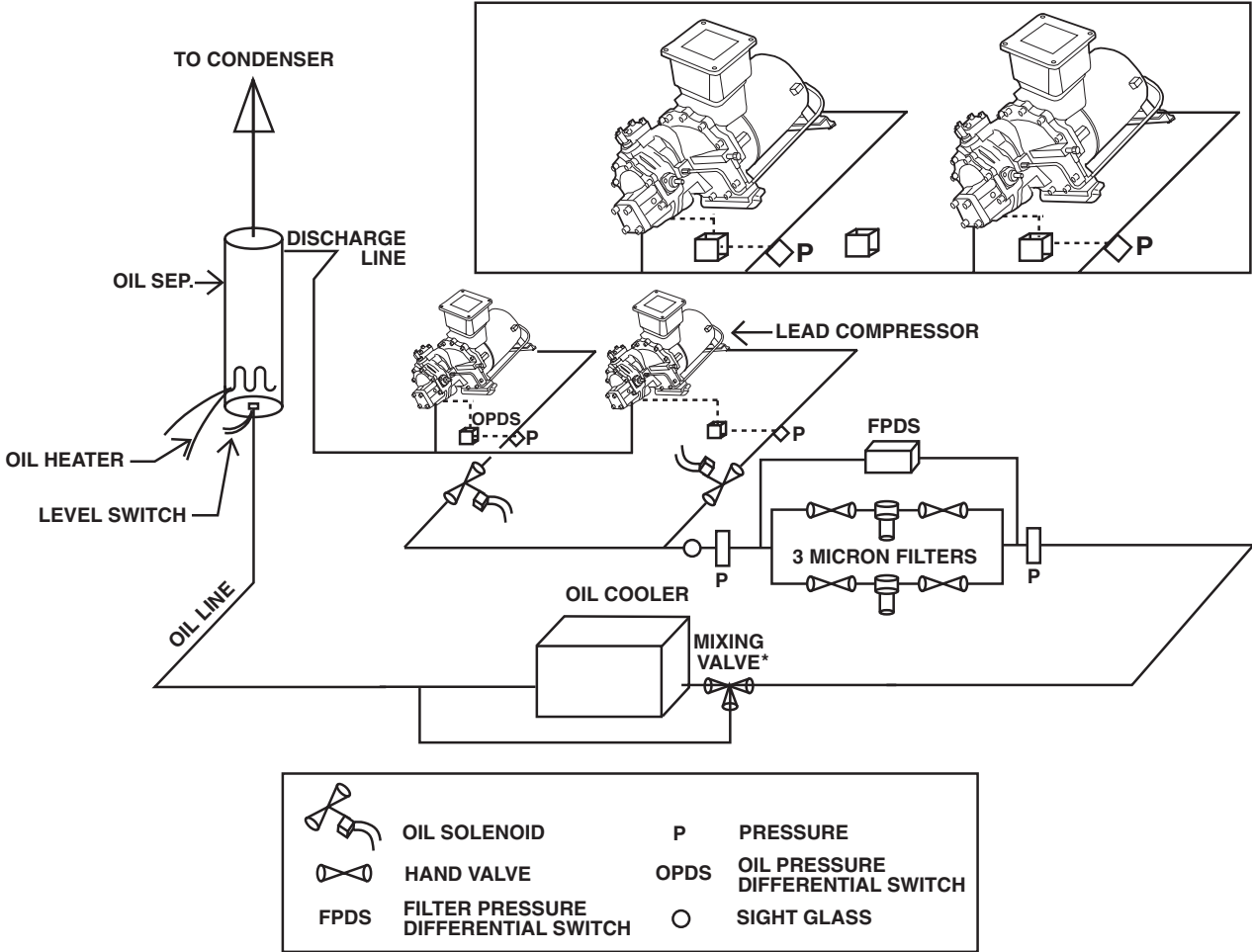

\*Note: Other oil temperature control options are available. See section 3.7.

# 4.0 Refrigerant Management System Used with Older Carlyle Electronic Module (CEM) Systems

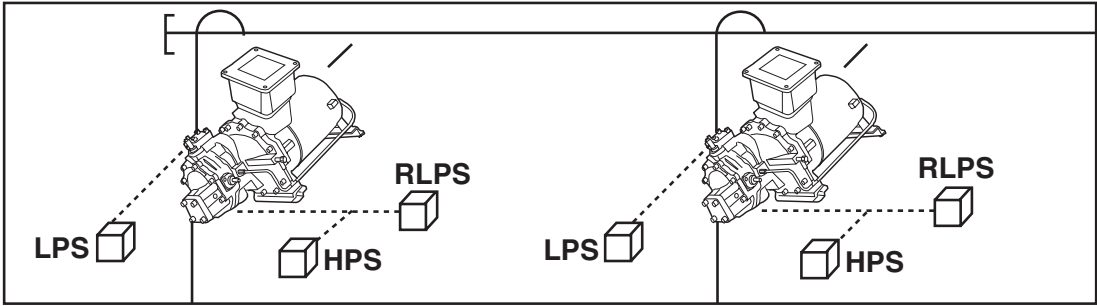
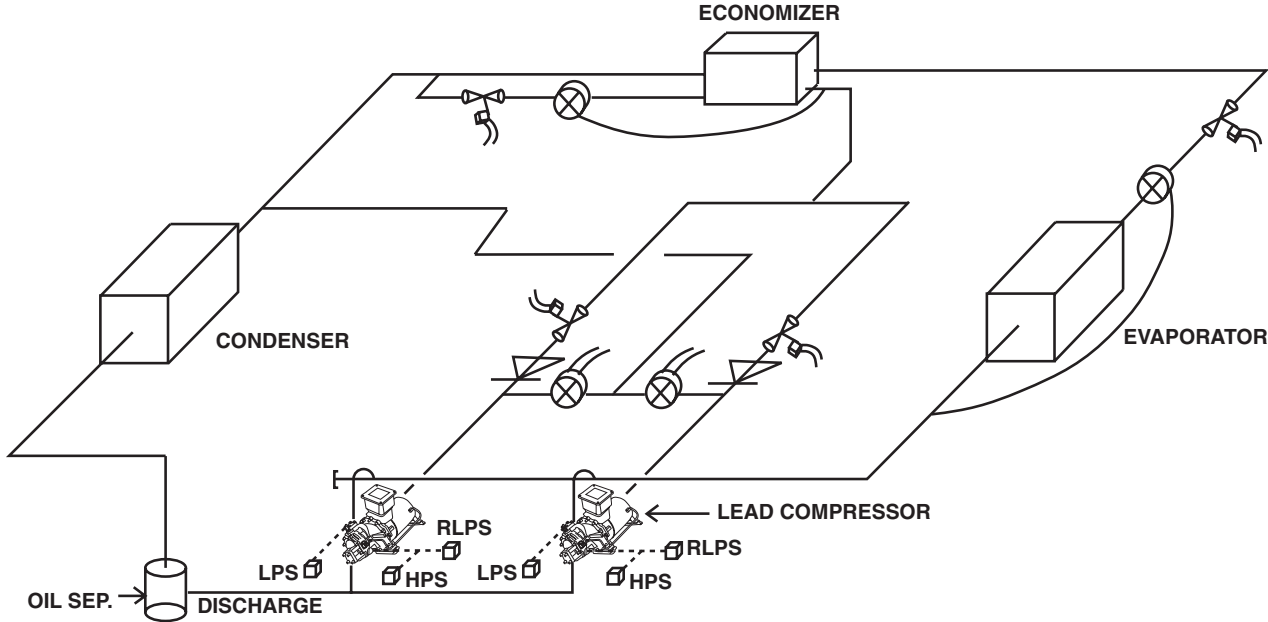

|      |                                      |  |                     |
|------|--------------------------------------|--|---------------------|
| HPS  | HIGH PRESSURE SWITCH                 |  | EXPANSION VALVE     |
| LPS  | LOW PRESSURE SWITCH                  |  | SOLENOID            |
| RLPS | REVERSE ROTATION LOW PRESSURE SWITCH |  | CHECK VALVE         |
|      |                                      |  | MOTOR COOLING VALVE |



---

Manufacturer reserves the right to discontinue, or change at any time, specifications or designs and prices without notice and without incurring obligations.

**CARLYLE COMPRESSOR DIVISION • ©CARRIER CORPORATION 2/02**  
P.O. Box 4808 • Syracuse, New York 13221  
Phone 1-800-532-5031 • Fax 1-315-432-3274  
In U.S. and Puerto Rico: 1-800-GO-CARLYLE (1-800-462-2759)  
In Canada: 1-800-258-1123  
In Mexico: 001-800-GO-CARLYLE (001-800-462-2759)  
001-888-GO-CARLYLE (001-888-462-2759)

Lit. No. 574-030  
(Rev F 09/04)