

Mobile Robots

# LD Series

## Autonomous Mobile Robots (AMRs)

Omron mobile robots are fully autonomous intelligent vehicles that increase throughput, reduce machine dwell time, eliminate errors, improve material traceability, and allow employees to focus on tasks that require complex human skills. What's more, unlike traditional AGVs, our mobile robots navigate by the natural features of the facility and require no expensive facility modification

LD Series mobile robots are easy to get up and running, requiring no construction such as the installation of magnets, and minimal programming. In addition, our software integrates with your other systems so you can get the solution up and running in minimal time.

- Easy to setup and operate
- Works safely with people
- Autonomous navigation doesn't require preset routes, magnets, beacons or facility modifications
- Easy to integrate with MES, ERP, and WMS systems
- Able to operate in fleets of up to 100 robots



**Part Number Configuration**      37    -

1 Robot Type			Symbol
LD 60/ LD 90			0
Cart Transporter			1
LD 250			2
2 Speed & Payload			Symbol
0.9m/s (Excludes LD 250)	90Kg (LD90)		6
	130Kg (Cart transporter)		
1.2m/s (LD 250 Only)	250Kg		2
1.3m/s (Excludes LD 250)	90Kg (LD90)		4
	105Kg (Cart transporter)		
1.8 m/s/ (LD 60 Only)	60Kg		3
3 Laser version			Symbol
Omron			2
4 Configuration			Symbol
Protection	Applicable Versions	Bundle Contents	
Standard	LD 60 / LD 90 / LD 250	Robot	00000
		Robot, Dock	00002
		Robot, Dock, Joystick, Top Plate	10004
	Cart Transporter	Robot	00010
		Robot, Dock	00012
		Robot, Dock, Joystick, Top Plate, Acuity, Cart	01014
ESD	LD 60 / LD 90	Robot	20000
		Robot Dock	20002
		Robot, Dock, Joystick, Top Plate	20004

## LD Series

### Components and Functions

#### LD-60, LD-90

##### Light Discs

Status indicator is located on both sides.

##### Front Bumper

Stops when in contact with an obstacle.



##### Safety Scanning Laser

Safety-rated laser used for SLAM (Simultaneous Localization and Mapping) and safety functionality.

##### Low Front Laser

Obstacle sensor detects low-profile objects when moving forward.



\*ESD Model Shown

##### AUX Power & I/O

Internal connections to power and control custom topper models.

##### Operation Panel

Access to system power, E-Stop, and the operation status display.

##### Rear Sonar

Detects rear obstacles using sonar.

##### Performance Battery

Up to 15 hours of runtime between charges for up to 7 years.

##### Charge Dock

Integrated contacts for automated charging.

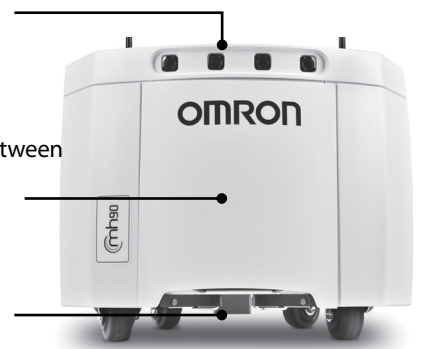

### Components and Functions

#### LD-250

##### Light Discs

Status indicator is located on both sides.

##### E-Stop Buttons

E-stop located on both sides and top.

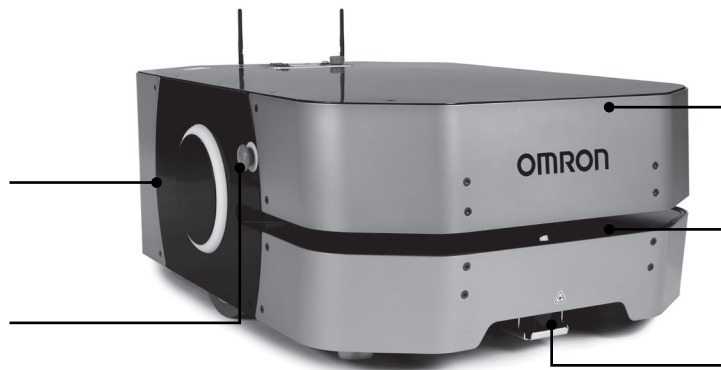

##### Hardened Construction

Metal chassis and skins for increased duty and durability.

##### Safety Scanning Laser

Safety-rated laser used for SLAM (Simultaneous Localization and Mapping) and safety functionality.

##### Low Front Laser

Obstacle sensor detects low-profile objects when moving forward.

##### Aux Power & I/O

Internal connections to power and control custom topper modules.

##### Performance Battery

Up to 13 hours of runtime between charges for up to 7 years.

##### Rear ToF Sensors

Detects rear obstacles using infrared light.



##### Operation Panel

Access to system power, E-Stop, and the operation status display.

##### Charge Dock







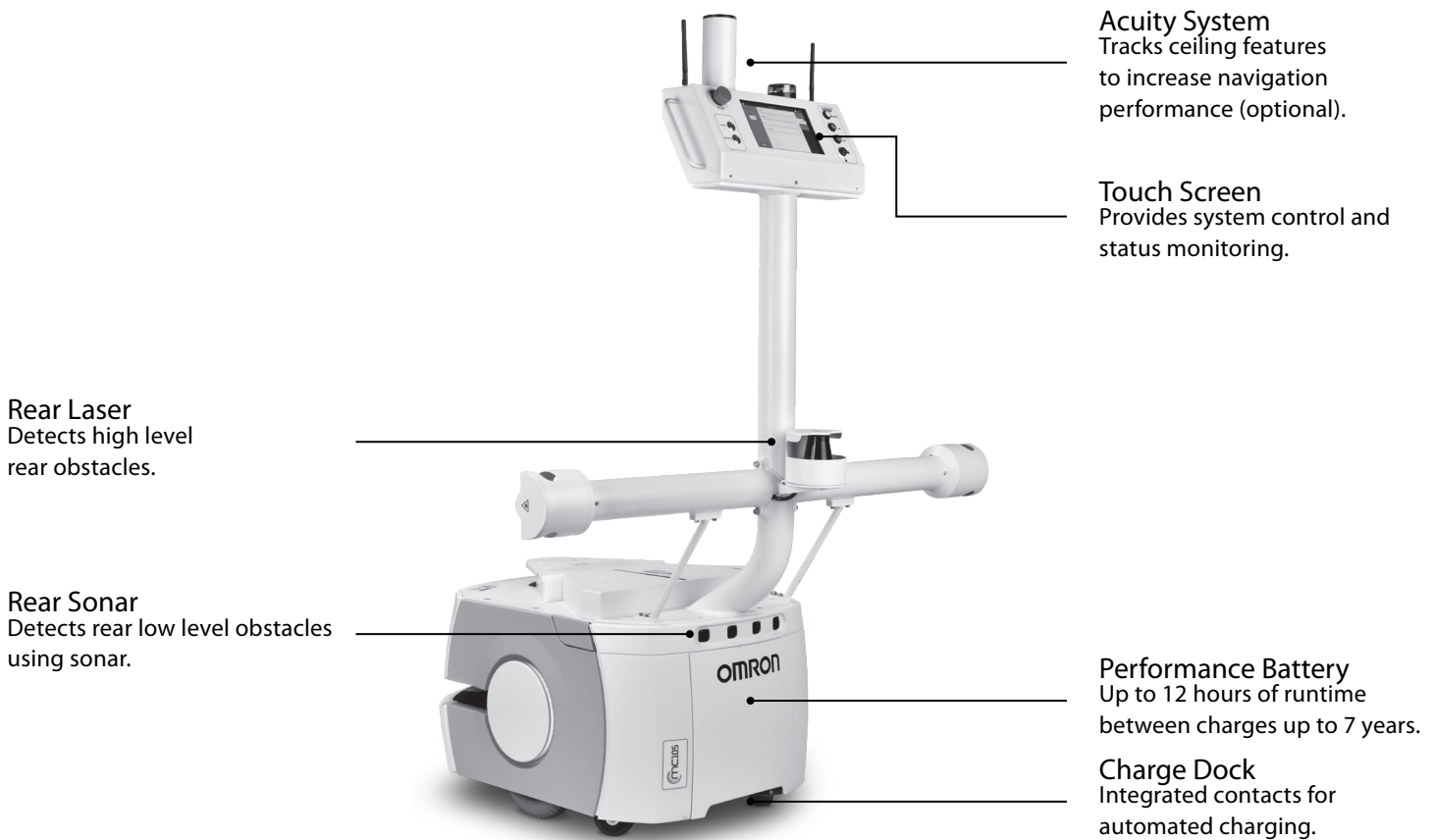
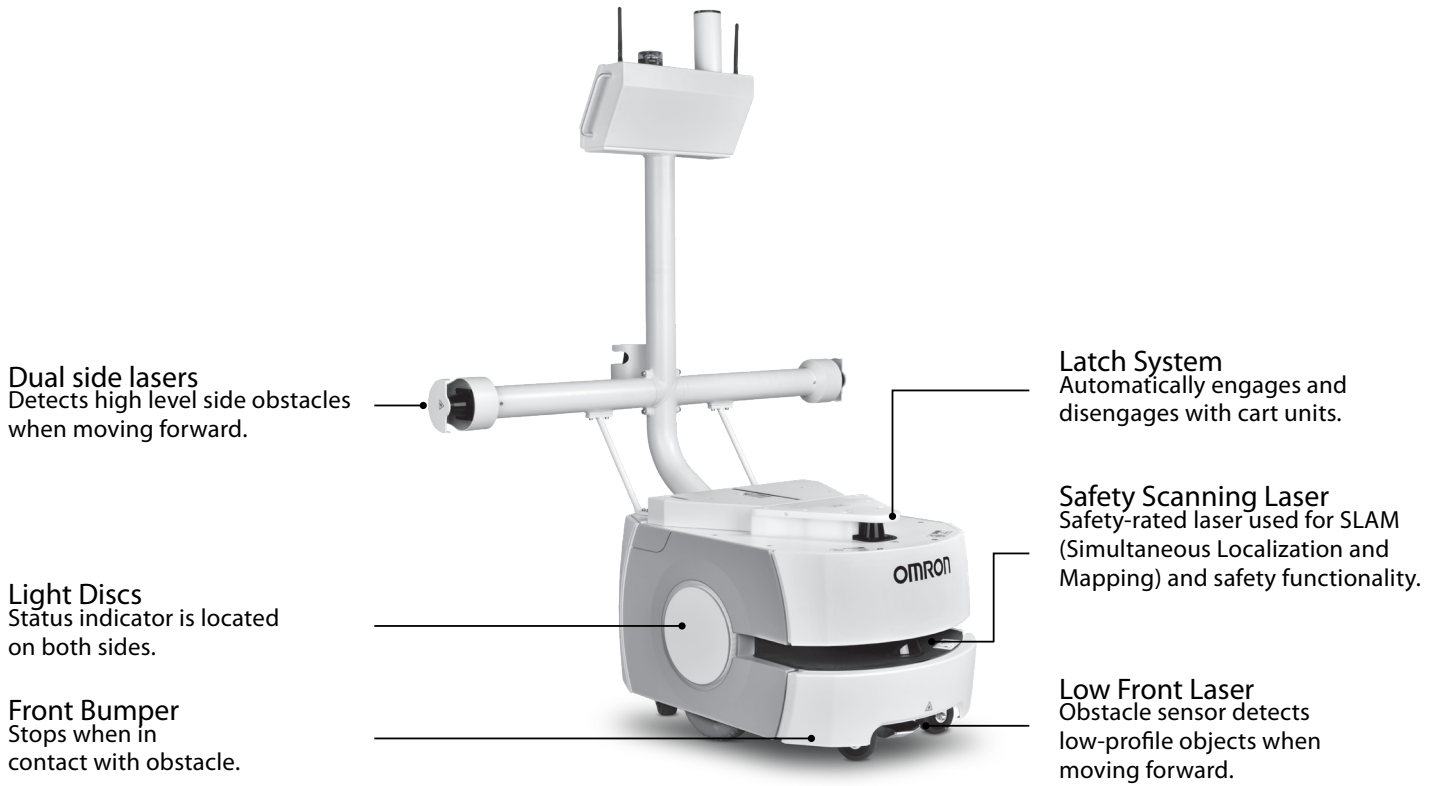

Integrated contacts for automated charging.

# Components and Functions







## Cart Transporter





## LD Series Options and Accessories

Appearance	Description	Specification	Configuration & Attachment	Part Number
 <p>High Accuracy Positioning System (HAPS)</p>	<p>A combination of sensor and magnetic tape to achieve accurate alignment during forward driving motion, when the sensor is attached to mobile robot and magnetic tape is on the floor.</p>	Single sensor - LD-60/ LD-90	Sensor × 1, mounting bracket × 1, power connector × 1, RS-232 connector × 1, 25 mm wide magnetic tape (south top side, 50 m roll)	13660-100
		Double sensor - LD-60/ LD-90	Sensor × 2, mounting bracket × 2, power connector × 1, RS-232 connector × 2, 25 mm wide magnetic tape (south top side, 50 m roll)	13660-000
		Single sensor - LD-250	Sensor × 1, mounting bracket × 1, power connector × 1, RS-232 connector × 1, 25 mm wide magnetic tape (south top side, 50 m roll)	21374-100
		Double sensor - LD-250	Sensor × 2, mounting bracket × 2, power connector × 1, RS-232 connector × 2, 25 mm wide magnetic tape (south top side, 50 m roll)	21374-000
Magnetic tape	Magnetic tape for the High Accuracy Positioning System. The tape is applied to signal the mobile robot where to stop	25 mm wide magnetic tape (south top side, 50 m roll)		14925-000
 <p>Cell Alignment Positioning System (CAPS)</p>	<p>Add on software license that improves the AMR's positional accuracy</p>	Software license	USB dongle with CAPS activated license for LD 60/90 and Cart Transporter	20271-805-OEI-69C
			USB dongle with CAPS activated license for LD 250	20271-805-OEI-250
 <p>Acuity Localization</p>	<p>Upwards facing camera that maps ceiling features/lights used where process layout or obstacle location changes often. Installed on a payload structure attached to the mobile robot.</p>		Camera, mounting kit, cables, leveling kit	13700-000
			Camera, mounting kit, cables	13700-100
 <p>Touchscreen</p>	<p>Allows operators to check the status of the mobile robot, enter goals, and pause the mobile robot. Installed on a payload structure attached to the mobile robot.</p>	-	<p>Touchscreen with bracket, power supply with bracket, power cable from core to power supply (33 cm), power cable from power supply to touchscreen (183 cm), Ethernet cable between touchscreen and core (153 cm), gasket between touchscreen and AMR mounting surface, software package including touchscreen support</p>	13605-000
 <p>Side Laser</p>	<p>Used to detect obstacles that are at heights the safety scanning laser of the mobile robot cannot detect. Installed on a payload structure attached to the mobile robot.</p>	Bundle	Laser × 2, cable × 1	13456-000
		Kit	Laser × 2, Cable × 1, mounting kit × 2, metal cover × 2	13456-100
 <p>Call/Door Box</p>	<p>Used to issue a request for a mobile robot to go to the goal or to open a closed door. Installed at the goal or door</p>	WiFi	Call/door box	13029-802
		Wired	Call/door box	13029-902
 <p>Battery</p>	<p>A battery that is installed in the mobile robot</p>	72 Ah Battery cell nominal capacity	Battery - LD-250	20452-000
 <p>AMR Legacy Upgrade Dongle</p>	<p>USB license dongle for AMRs migrating from MMS 4.x to FLOW Core</p>	-FLOW Core	USB dongle with 5 year FLOW Core license (Only for AMRs migrating from MMS 4.x to FLOW Core)	20271-301-OEI-5
		-FLOW Core -CAPS	USB dongle with 5 year FLOW Core license and CAPS license (Only for AMRs migrating from MSS 4.x to FLOW Core)	20271-301-805-OEI-5



Appearance	Description	Specification	Configuration & Attachment	Part Number
 Docking Station	A docking station to charge the battery installed in the mobile robot.	–	Docking station, AC power cable	12477-000
		Extended Wall mount	Docking station, AC power cable, extended wall mount (for Cart Transporter)	12477-050
 Joystick	Used for manually controlling the mobile robot	Cable length: 0.6 to 3 m	–	13558-000
 Breakout Cable	A D-SUB44 pin cable for digital I/O interface of the mobile robot.	–	DB44HD breakout cable (D-SUB44 pin cable for digital I/O interface)	14165-000
 Top Plate - LD-60, LD-90	A upper plate of the mobile robot OEM. It is not necessary for building customer payload	Top cover for OEM type	LD-60 LD-90	12944-000
 Top Plate - LD-250	A upper plate of the mobile robot OEM. It is not necessary for building customer payload	Top cover for OEM type	LD-250	20458-002
 Cart*	A cart designed to work seamlessly with the mobile robot cart transporter.	–	The cart only applies to LD-CT models.	75020-000
 Battery charging cable	A cable to connect a battery and docking station to charge the battery outside of the mobile robot	Cable length: 0.45 m	–	12676-000L

### Fleet Management Solutions

Appearance	Product Name	Specification	Configuration & Attachment	Part Number
	Primary Fleet Manager		EM2100 Appliance with 5 year Fleet Operations Workspace License	20271-900-OEI-5
	Secondary Fleet Manager		EM2100 Appliance with 5 year Fleet Operations Workspace License	20271-901-OEI-5
	Replacement Enterprise Manager		EM2100 Replacement Unit. (Must use license dongle from outgoing EM2100)	1168-200F
	MobilePlanner	Version 4.x	Installer (USB)* License Dongle MSS 4.x compatible only (NOT COMPATIBLE with FLOW Core)	13495-200

\* To obtain the latest version of the Fleet Operations Workspace (FLOW) Core software, contact your local OMRON representative.

## Specifications

### Mobile Robots-LD Platform LD-60, LD-90, LD-250, and Cart Transporter

Item	LD-60, LD-90		LD-250	Cart Transporter		Note
	37032-□□□□	37042-□□□□	37222-□000□	37142-□□□□	37162-□□□□	
Materials	Polycarbonate		Aluminum	Polycarbonate		
Dimension (L × W × H)	699 × 500 × 383 mm *1		963 × 718 × 383 mm *1	894 × 1074 × 1394 mm *2		*1 Height to top plate *2 Height includes WiFi antenna
Weight (with Battery)	62 kg		148kg (with battery) 129kg (without battery)	81 kg (Vehicle)/23 kg (Cart)		
<b>Environment</b>						
Ambient temperature	5 to 40 °C					
Ambient humidity	5 to 95 % (non-condensing)					
Operating Environment	Indoor usage only, no excessive dust, no corrosive gas					Direct sunlight may cause safety laser false positive
IP rating	IP20					
Cleanroom rating	Fed Class 100, ISO Class 5			None		
<b>Floor Conditions</b>						
Floor Requirements	Linoleum, epoxy, or concrete (no water, no oil, no dirt)					
Minimum floor flatness	FF25 (ACI 117 standard)*3					*3 ACI 117 is the American Concrete Institute standard for concrete floors. FF is flatness, FL is the level. Higher FF numbers represent flatter floors. FF25 is a fairly lenient specification.
Traversable step	15 mm max*4	10 mm max*4	10 mm max *5	5 mm max. *6	5 mm max. *6	*4 A speed of 250-300 mm/s and 250 mm/s, for the LD-60 and LD-90, is required for these steps. Faster or frequent driving over such steps or gaps will shorten the lifespan of the drivetrain components. Lower speeds may not traverse the step. Steps should have smooth, rounded profiles. *5 For LD-250, the robot should traverse the 10mm step at 600 mm/s or slower for best performance of the laser and battery *6 The Cart Transporter with a cart is capable of driving over a gap or step of 5 mm at a speed of 250 mm/s, but this should not be regarded as normal use. Regular driving over such gaps or steps will shorten the lifespan of the drivetrain components.
Traversable gap	15 mm max	15 mm max	15 mm max	5 mm max. *6	5 mm max. *6	
Climb grade	Below 1: 12 (60 kg max.) Flat floor only (over 60 kg)		Flat floor only (full payload)	Flat floor only		
<b>Navigation</b>						
Routing	Autonomous routing by localizing with safety scanning laser based on environment mapping					
Environmental map making method	Scan by walking the mobile robot through the environment, and upload the scan data in the MobilePlanner					
<b>Payload</b>						
Maximum Weight	60 kg	90 kg	250 kg	105 kg*7	130 kg*7	*7 Excluding cart weight
<b>Mobility</b>						
Maximum Speed	1800 mm/s	1350 mm/s	1200mm/s	1350 mm/s	900 mm/s	
Maximum Rotation Speed	180°/s	180°/s	120°/s	100°/s		

Item	LD-60, LD-90		LD-250	Cart Transporter		Note
	37032-□□□□	37042-□□□□	37222-□000□	37142-□□□□	37162-□□□□	
Stop Position Accuracy	± 100 mm position*8, ± 2° rotation					*±10 mm position, ±0.5° rotation with HAPS option ±25 mm position, ±1.0° rotation with CAPS option
<b>Drive wheel</b>						
Materials	Non-marking nylon foam-filled rubber, non-conductive		Aluminum with polyurethane tread	Non-marking nylon foam-filled rubber, non-conductive		
Size	200 dia. × 50 mm nominal, 2 wheels					
<b>Passive caster</b>						
Materials	Conductive thermoplastic rubber on polyolefin		Conductive solid polyurethane	Conductive thermoplastic rubber on polyolefin		
Size	75 dia. × 41 mm nominal, 4 casters		127 dia. × 51 mm nominal, 4 casters	75 dia. × 41 mm nominal, 4 casters		
<b>Power</b>						
Battery	22-30 VDC					Lithium iron phosphate (LiFePO <sub>4</sub> )
Capacity	72 Ah Battery cell nominal capacity					
Run Time	15 hours (continuous) approx.		13 hours (continuous) approx	15 hours (continuous) approx.		With no payload condition
Recharge Time	4 hours (5:1 ratio) approx.					
Battery Life Cycles	2,000 recharge cycles (battery cell nominal)					
Charging Method	Automatic / manual					
Auxiliary Power	5 VDC±5%, 1 A switched Aux power 12 VDC±5%, 1 A switched Aux power 20 VDC±5%, 1 A switched Aux power 22-30 VDC, 4 A switched × 2 22-30 VDC, 10 A switched*10 22-30 VDC, 10 A safe, switched*10					5, 12, 20, and 22-30 VDC power can be provided to external devices *10. 10 A switched and 10 A safe, switched share the 10 A of current
<b>Standard</b>						
Harmonized Standard	EN ISO 12100 / EN ISO 13849-1 / EN 60204-1					
Relevant Standard	EN 1525 / ANSI B56.5					
Wireless	IEEE 802.11 a/b/g					
<b>Safety Features</b>						
Safety Scanning Laser	1 at front Class 1 PLd safety per ISO13849-1 3 m maximum radius from laser for safety zones 40 m radius for general sensing 240° field of view					
Emergency Stop	1 at operator panel		1 at operator panel, 1 on each side (3 total)	1 at HMI post touchscreen, 1 at operator panel		
Rear Sonar	2 at rear, 2 m range		Time of flight (TOF) sensors	2 at rear, 2 m range		Each pair includes one emitter and one receiver working together
Front Bumper	1 at front of platform, 2 pairs of sensors		Fixed, non-sensing	1 at front of platform, 2 pairs of sensors		
Low Front Laser	1 at front of platform Class 1 4 m maximum range 126° field of view					
Side Laser	Option*11			2 on horizontal tubes of HMI post Class 1 4 m maximum range 270° field of view		*11. 2 on sides of payload structure, usermounted
Indicators	Light disc on each side			Light disc in each side, beacon on HMI post		
Speaker	3.5 in., 80 W max.					
<b>Operator Interface</b>						
Screen / Touch Panel	3.5 in. TFT 320 × 240 pixels, color screen			7.0 in. TFT LCD touch panel, 18/24 bit RGB		
Button	On button: green Off button: red Brake-release button: orange Keyswitch (disabled off button) *12			On button: green Off button: red Brake-release button: orange Keyswitch (disabled off button) *12, Latch button, unlatch button		*12. Key switch can be used to disable the off button to avoid accidental shutdown or tampering.
<b>User Interface</b>						
Wireless	IEEE 802.11 a/b/g					
Ethernet Port	1 x user LAN, 1 x maintenance LAN, Auto-MDIX					
Serial	RS-232 × 2					
Digital I/O	16 inputs, 16 outputs					
Analog I/O	8 inputs (0 to 30 V), 4 outputs (0-20 V)					
Audio	Digital audio out, audio in / audio out					
<b>Cart Latching</b>						
Latching Method	Not available			Automatic		

## MobilePlanner Software

<b>Operating System</b>	Windows 10 (32-bit/64-bit version)
<b>CPU</b>	1.5 GHz dual-core CPU recommended
<b>Main Memory</b>	1.5 GB min. (4 GB min. recommended)
<b>Hard Disk</b>	At least 200 MB of available space
<b>Video Memory</b>	256 MB min.
<b>Display</b>	XGA 1024 × 768, 16 million colors
<b>Supported Languages</b>	Japanese, English, German

## Fleet Manager

<b>Dimensions - W × D × H</b>	430 × 495.3 × 43.7 mm
<b>Weight</b>	9.1 kg
<b>Mounting method</b>	1U rack mount in a standard 19-inch equipment rack
<b>Power Supply</b>	100-240 VAC (typical 100 W)
<b>Power Consumption</b>	200W max.
<b>Operating Temperature</b>	10 to 35 °C
<b>Storage Temperature</b>	-25 to 60 °C
<b>Operating Humidity</b>	8 to 90%, non-condensing
<b>Storage Humidity</b>	5 to 95%, non-condensing
<b>Chassis protection class</b>	IP20
<b>CPU</b>	Intel® Xeon® CPU
<b>Main Memory</b>	32 GB DDR3
<b>Storage</b>	60 GB SSD
<b>Archive Storage</b>	4 TB HDD
<b>Communication port</b>	10/100/1000 Ethernet × 4, USB × 4, VGA
<b>Status Display</b>	Multi-segment LCD

## High Accuracy Positioning System

<b>Part Number</b>	13660-□□00 (LD-60/90/105CT/130CT) 21374-□□00 (LD-250)	
<b>Sensor</b>	<b>Depth</b>	30 mm
	<b>Width</b>	160 mm
	<b>Rating</b>	IP64
	<b>Environment</b>	-40 to 85 °C
	<b>LEDs</b>	Power, tape present, left marker, right marker
<b>Magnetic Tape</b>	<b>Width</b>	25 mm
	<b>Orientation</b>	South up
<b>Markers (Magnetic Tape)</b>	<b>Length</b>	25 mm
	<b>Orientation</b>	300 mm min. for 500 mm/s drive speed North up
	<b>Separation From Tape</b>	15 - 30 mm
<b>Connections</b>	<b>Front Sensor</b>	RS232-1 (/dev/ttyUSB9) on the core
	<b>Rear Sensor</b>	RS232-2 (/dev/ttyUSB10) on the core
	<b>Power, Both Sensors</b>	Aux power using the included splitter cable

## Acuity Localization

<b>Part Number</b>	13700-□□00
<b>Field of View</b>	140°
<b>Power Input</b>	12 VDC (±10%) supplied from platform through power connector
<b>Power Consumption</b>	3.3 W maximum

## Cell Alignment Positioning System (CAPS)

<b>Stop Position Accuracy</b>	* ±25 mm position, ±1.0° rotation
<b>Type</b>	Software license

## Fleet Simulator

<b>Part Number</b>	20271-804
<b>Type</b>	Software license
<b>Function</b>	Provides Simulation Capabilities to existing Fleet Manager

## Touchscreen

<b>Part Number</b>	13605-000
<b>Touch Panel</b>	PCAP touch sensor, black-bordered cover lens
<b>TFT Display</b>	TFT LCD panel, 18/24 bit RGB parallel interface, 7.0 in. WVGA - wide viewing angles, 5-touch
<b>Backlight</b>	Constant current LED supply
<b>Power Input</b>	5 VDC supplied through power connector
<b>Power Consumption</b>	6.5 W maximum

## Call/Door Box

<b>Part Number</b>	WiFi	13029-802
	Wired	13029-902
<b>Dimensions - W × D × H</b>	141.4 × 74.7 × 30 mm	
<b>Weight</b>	190 g	
<b>Mounting method</b>	Mount to the provided wall frame with four screws	
<b>Power Supply</b>	12 VDC	
<b>Power Consumption</b>	0.5 A, 6 W typical	
<b>WiFi</b>	IEEE 802.11 a/b/g/n	
<b>Communication Port</b>	Ethernet	
<b>I/O</b>	Input × 2, output × 2 (30 VDC, 2 A max.)	

## Battery

<b>Run Time (No Payload)</b>	15 hours (continuous) approx. (LD-60/90) 13 hours (continuous) approx. (LD-250)
<b>Weight</b>	19 kg
<b>Voltage</b>	22-30 VDC
<b>Capacity</b>	72 Ah (battery cell nominal)
<b>Recharge Time</b>	4 hours approx.
<b>Life Expectancy</b>	2,000 times 80% DOD (battery cell nominal), 7 years, approx., 16 hrs/day, 5 days/wk 4 years, approx., 19/7 (full-time)

## Docking Station

<b>Part Number</b>	12477-000, 12477-050
<b>Current</b>	8 A*1
<b>Contacts</b>	2
<b>Power</b>	100 to 240 VAC, 50 to 60 Hz
<b>Power Consumption</b>	800 W
<b>Humidity</b>	5 to 95 %, non-condensing
<b>Temperature</b>	5 to 40° C
<b>Dimensions (W × D × H)</b>	349 × 369 × 315 mm 495 × 495.5 × 317 mm (with floor plate)
<b>Weight</b>	8.2 kg
<b>Mounting</b>	Wall bracket, directly to floor, or on floor with floor plate
<b>Indicators</b>	Power on: blue Charging: yellow
<b>Connector</b>	For out-of-platform battery charging

\*1 Thermal fuse in AC power switch (10 A time-lag fuse at switch for legacy)

## Joystick

<b>Part Number</b>	13558-000
<b>Weight</b>	0.55 kg
<b>IP Rating</b>	IP56

## Cart

<b>Part Number</b>	75020-000
<b>Dimensions (L × W × H)</b>	592 × 846 × 480 mm
<b>Weight</b>	23 kg
<b>Rating</b>	ESD-rated
<b>Passive Casters</b>	2 front, 2 rear, spring-loaded
<b>Caster Diameter</b>	100 mm nominal
<b>Caster Brakes</b>	At 2 rear casters

# Dimensions

CAD data can be downloaded from Omron's website.  
<https://automation.omron.com/en/us/support/cad-library>

(Unit: mm)

## Mobile Robots-LD Platform LD-60, LD-90

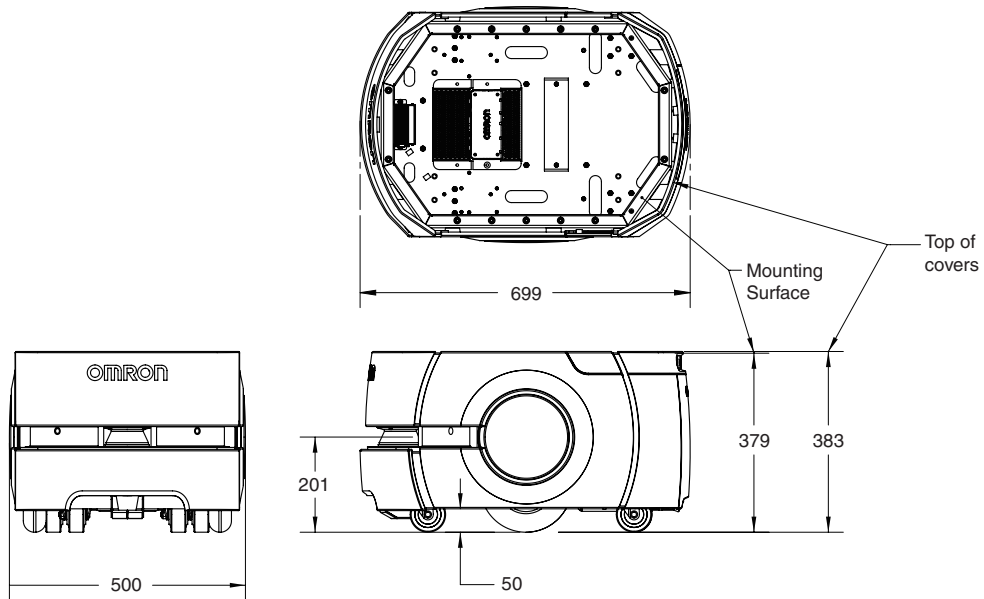

## LD-250

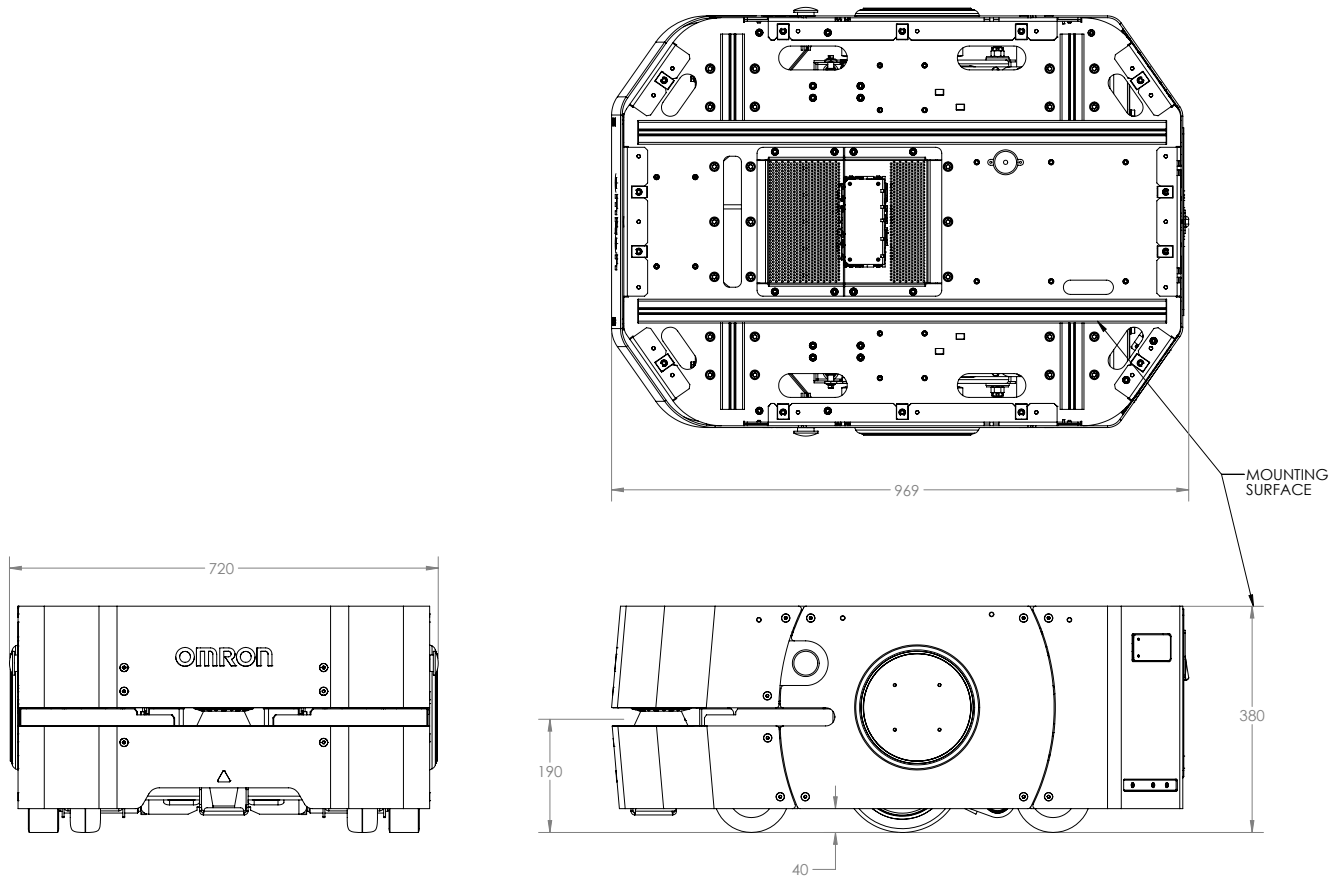

# Dimensions

(Unit: mm)

## Cart Transporter

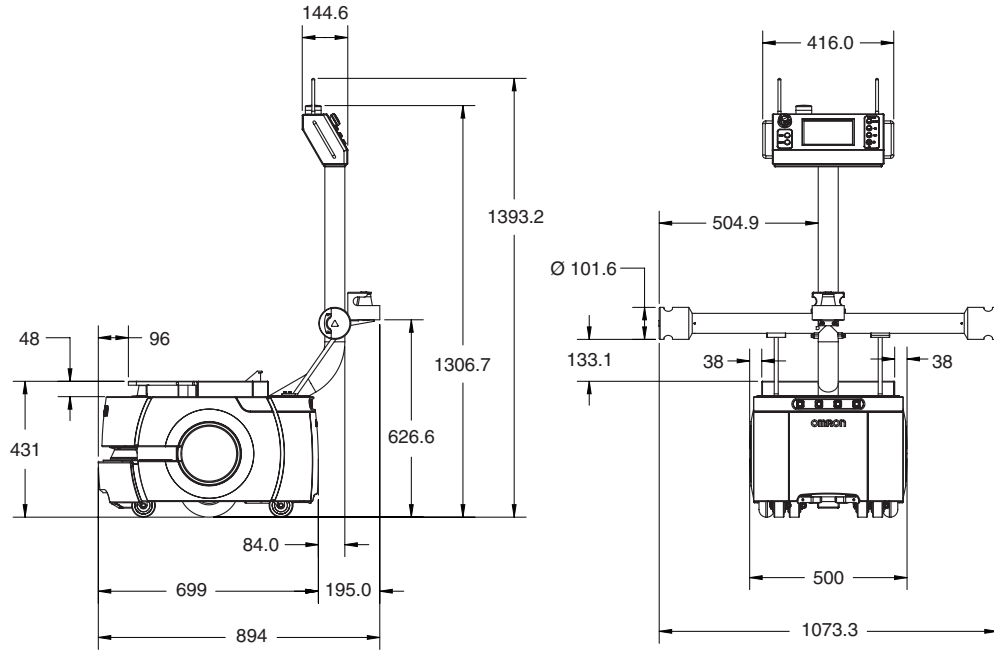

## Fleet Manager EM2100 Appliance

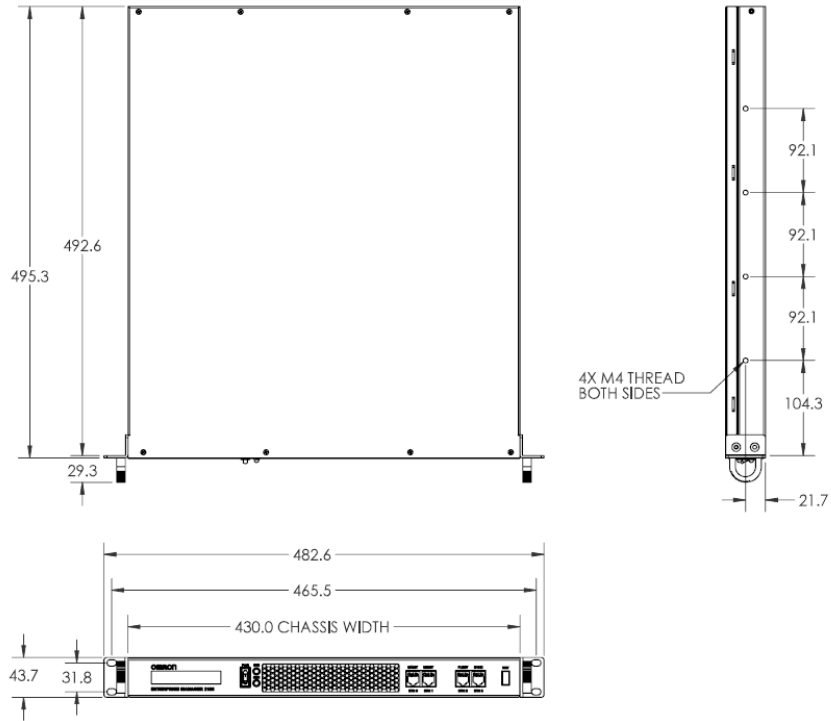
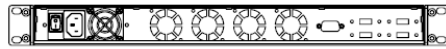



# Dimensions

## High Accuracy Positioning System

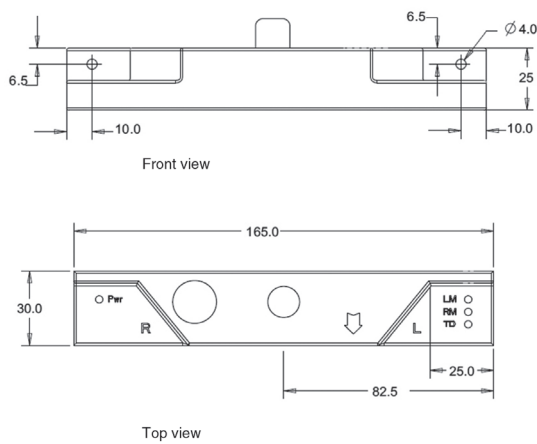

## Docking Station

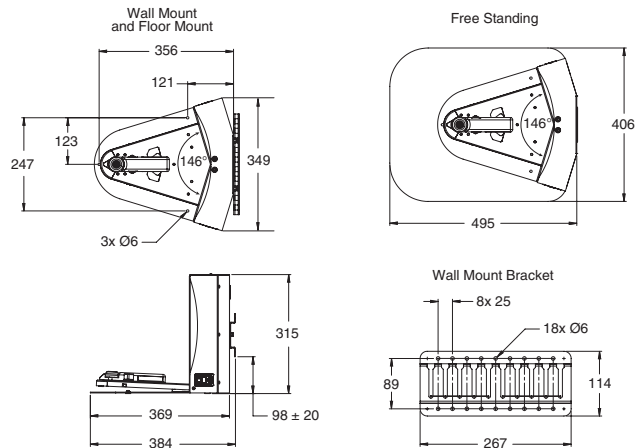

## Acuity Localization

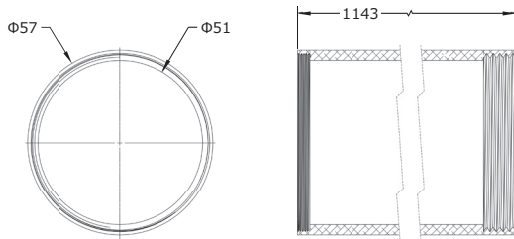

## Joystick

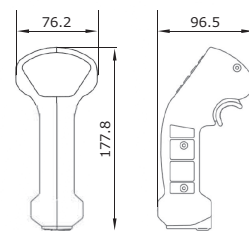

## Touchscreen

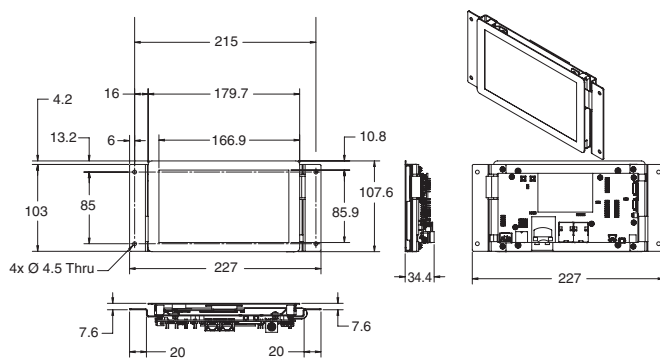

## Call/Door Box

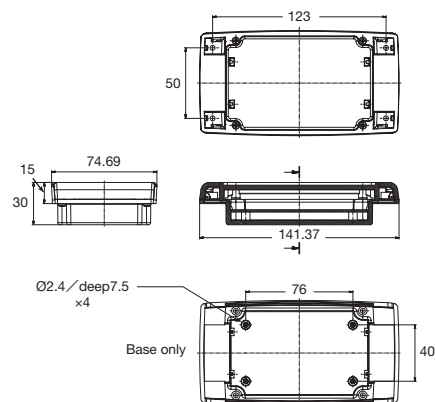

## Cart

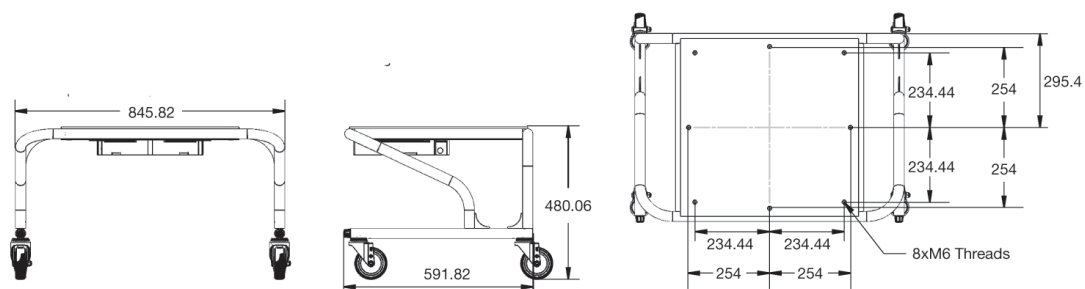

## Related Manuals

Manual No.	English Title
I611	Mobile Robots LD Platform User Guide
I612	Mobile Robots LD Cart Transporter User Guide
I613	Mobile Robots LD Platform Peripherals Guide
I614	Mobile Robots Software Suite User Guide
I615	Enterprise Manager User Guide
I616	Mobile Robot LD Safety Guide
I617	Advanced Robotics Command Language Reference Guide
I618	Advanced Robotics Command Language Enterprise Manager Integration Guide
I634	EM2100 Installation Guide
I635	Fleet Operations Workspace Core User Guide
I636	Fleet Operations Workspace Core Migration Guide
I637	Fleet Operatiom Workspace Core Integration Toolkit User Guide
I642	LD-250 Platform User Guide

- Intel, Xeon and Intel Xeon are trademarks of Intel Corporation in the U.S. and/or other countries.
- Other company names and product names in this document are the trademarks or registered trademarks of their respective companies.
- The product photographs and figures that are used in this catalog may vary somewhat from the actual products.
- Microsoft product screen shot(s) reprinted with permission from Microsoft Corporation.

**OMRON AUTOMATION AMERICAS HEADQUARTERS** • Chicago, IL USA • 847.843.7900 • 800.556.6766 • automation.omron.com

**OMRON CANADA, INC. • HEAD OFFICE**

Toronto, ON, Canada • 416.286.6465 • 866.986.6766 • automation.omron.com

**OMRON ELECTRONICS DE MEXICO • HEAD OFFICE**

Ciudad de México • 52.55.5901.4300 • 01.800.386.6766 • mela@omron.com

**OMRON ELECTRONICS DE MEXICO • SALES OFFICE**

San Pedro Garza García, N.L. • 81.12.53.7392 • 01.800.386.6766 • mela@omron.com

**OMRON ELECTRONICS DE MEXICO • SALES OFFICE**

Eugenio Garza Sada, León, Gto • 01.800.386.6766 • mela@omron.com

**OMRON ELETRÔNICA DO BRASIL LTDA • HEAD OFFICE**

São Paulo, SP, Brasil • 55 11 5171-8920 • automation.omron.com

**OMRON ARGENTINA • SALES OFFICE**

Buenos Aires, Argentina • +54.11.4521.8630 • +54.11.4523.8483  
mela@omron.com

**OTHER OMRON LATIN AMERICA SALES**

+54.11.4521.8630 • +54.11.4523.8483 • mela@omron.com