

Installation Manual

Generac PWRcell™ Inverter

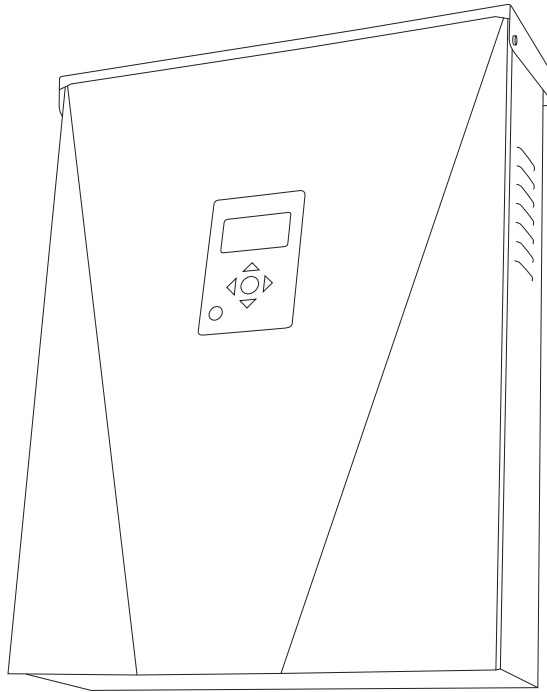

009954



WARNING

Loss of life. This product is not intended to be used in a critical life support application. Failure to adhere to this warning could result in death or serious injury.

(000209b)

Register your Generac product at:

<https://register.generac.com/>

1-888-GENERAC
(888-436-3722)

Para español, visita: <http://www.generac.com/service-support/product-support-lookup>

Pour le français, visiter: <http://www.generac.com/service-support/product-support-lookup>

SAVE THIS MANUAL FOR FUTURE REFERENCE

Use this page to record important information about your Generac Product

Record the information found on your unit data label on this page. See [Serial Number Locations](#).

When contacting an Independent Authorized Service Dealer (IASD) or Generac Customer Service, always supply the complete model number and serial number of the unit.

Table 1: Generac PWRcell Inverter Important Information

Unit Model Number	
Unit Serial Number	
Date Purchased	
Commissioning Date	

 **WARNING**

CANCER AND REPRODUCTIVE HARM

www.P65Warnings.ca.gov

(000393a)

Section 1: Safety Rules & General Information

Introduction	1
Safety Rules	1
General Hazards	2
Electrical Hazards	3
Safety Shutdown	3

Section 2: General Information

Specifications	5
Ratings	5
Serial Number Location	6
Unit Dimensions	6
About Generac PWRcell Inverters	6
Component Locations	7
Inverter Control Panel	7
LED Indicators	7

Section 3: Location and Compliance

Location	9
Compliance	9
Safety Shutdown	9
Voltage and Frequency Trip Thresholds	10

Section 4: Installing PWRcell Inverter

Mounting the Inverter	11
-----------------------------	----

Section 5: Electrical Connections

Generac PWRcell Inverter Wiring Compartment	13
Accessing Wiring Compartment	13
Knockout Dimensions and Locations	14
Wiring Guidelines	15
Grounding Bar Wiring	15
DC Wiring	16
AC Wiring	16
Protected Load	17
Current Transformers (CTs)	18
Other Accessories	20

Section 6: Commissioning and Setup

System Configuration	21
Enabling Islanding	21
General Information	21
Commissioning the System	21
Generac REbus Beacon Setup	23
Ethernet Setup	26
Serial Number and Registration	28

Section 7: Maintenance

Service	29
Accessing Wiring Compartment	29
Replacing Fuses	29

Section 8: Troubleshooting

General Troubleshooting	31
-------------------------------	----

This page intentionally left blank.

Section 1: Safety Rules & General Information

Introduction

Thank you for purchasing a Generac PWRcell™ Inverter. The Generac PWRcell Inverter is a storage-ready inverter that connects to the Generac PV Link™ and Generac PWRcell Batteries to form the Generac PWRcell system.

This manual provides instructions for installing the Generac PWRcell Inverter, including mounting, wiring, and battery integration information. The companion document to this installation manual is the Generac PWRcell Inverter Owner's Manual. See the owner's manual for complete information on programming and configuring the Generac PWRcell Inverter.

The information in this manual is accurate based on products produced at the time of publication. The manufacturer reserves the right to make technical updates, corrections, and product revisions at any time without notice.

Read This Manual Thoroughly



WARNING

Consult Manual. Read and understand manual completely before using product. Failure to completely understand manual and product could result in death or serious injury.

(000100a)

If any section of this manual is not understood, contact the nearest Independent Authorized Service Dealer (IASD) or Generac Customer Service at 1-888-436-3722 (1-888-GENERAC), or visit www.generac.com for assistance. The owner is responsible for correct maintenance and safe use of the unit.

This manual must be used in conjunction with all other supporting product documentation supplied with the product.

SAVE THESE INSTRUCTIONS for future reference. This manual contains important instructions that must be followed during placement, operation, and maintenance of the unit and its components. Always supply this manual to any individual that will use this unit, and instruct them on how to correctly start, operate, and stop the unit in case of emergency.

Safety Rules

The manufacturer cannot anticipate every possible circumstance that might involve a hazard. The alerts in this manual, and on tags and decals affixed to the unit, are not all inclusive. If using a procedure, work method, or operating technique that the manufacturer does not specifically recommend, verify that it is safe for others and does not render the equipment unsafe.

Throughout this publication, and on tags and decals affixed to the unit, DANGER, WARNING, CAUTION, and NOTE blocks are used to alert personnel to special instructions about a particular operation that may be hazardous if performed incorrectly or carelessly. Observe them carefully. Alert definitions are as follows:

DANGER

Indicates a hazardous situation which, if not avoided, will result in death or serious injury.

(000001)

WARNING

Indicates a hazardous situation which, if not avoided, could result in death or serious injury.

(000002)

CAUTION

Indicates a hazardous situation which, if not avoided, could result in minor or moderate injury.

(000003)

NOTE: Notes contain additional information important to a procedure and will be found within the regular text of this manual.

These safety alerts cannot eliminate the hazards that they indicate. Common sense and strict compliance with the special instructions while performing the action or service are essential to preventing accidents.

How to Obtain Service

For assistance, contact the nearest Independent Authorized Service Dealer (IASD) or Generac Customer Service at 1-888-436-3722 (1-888-GENERAC), or visit www.generac.com.

When contacting an IASD or Generac Customer Service, always supply the complete model and serial number of the unit as given on its data decal located on the unit. Record the model and serial numbers in the spaces provided on the front cover of this manual.

General Hazards



⚠ DANGER

Electrocution. Do not wear jewelry while working on this equipment. Doing so will result in death or serious injury.

(000188)

⚠ DANGER

Automatic start-up. Disconnect utility power and render unit inoperable before working on unit. Failure to do so will result in death or serious injury.

(000191)



⚠ WARNING

Electrocution. Potentially lethal voltages are generated by this equipment. Render the equipment safe before attempting repairs or maintenance. Failure to do so could result in death or serious injury.

(000187)

⚠ WARNING

Risk of injury. Do not operate or service this machine if not fully alert. Fatigue can impair the ability to service this equipment and could result in death or serious injury.

(000215)



⚠ WARNING

Loss of life. This product is not intended to be used in a critical life support application. Failure to adhere to this warning could result in death or serious injury.

(000209b)

⚠ WARNING

Equipment damage. Connect only to REbus-compatible devices to the DC bus. Never connect to any other DC power source. Connecting to other DC power sources could result in equipment damage.

(000598)

⚠ WARNING

Electric shock. Only a trained and licensed electrician should perform wiring and connections to unit. Failure to follow proper installation requirements could result in death, serious injury, and equipment or property damage.

(000155a)

⚠ WARNING

Equipment damage. Only qualified service personnel may install, operate, and maintain this equipment. Failure to follow proper installation requirements could result in death, serious injury, and equipment or property damage.

(000182a)

⚠ WARNING

Equipment damage. Connecting inverter to electric utility grid must only be done after receiving prior approval from utility company. Failure to do so could result in equipment or property damage.

(000640)

- Connecting Generac PWRcell Inverter to the electric utility grid must only be done after receiving prior approval from the utility company.
- Only competent, qualified personnel should install, operate, and service this equipment. Strictly comply to local, state, and national electrical and building codes. When using this equipment, comply with regulations established by the National Electrical Code (NEC), CSA Standard; the Occupational Safety and Health Administration (OSHA), or the local agency for workplace health and safety.
- Protection against lightning surges in accordance with local electric codes is the responsibility of the installer.
- If working on this equipment while standing on metal or concrete, place insulative mats over a dry wood platform. Work on this equipment only while standing on such insulative mats.
- Never work on this equipment while physically or mentally fatigued.
- Any voltage measurements should be performed with a meter that meets UL3111 safety standards, and meets or exceeds overvoltage class CAT III.

Electrical Hazards



⚠ DANGER

Electrocution. Water contact with a power source, if not avoided, will result in death or serious injury.

(000104)



⚠ DANGER

Electrocution. PWRcell Battery front cover should be removed by a qualified technician only. Removing the front cover could result in death, serious injury, equipment or property damage.

(000604)



⚠ DANGER

Electrocution. In the event of electrical accident, immediately shut power OFF. Use non-conductive implements to free victim from live conductor. Apply first aid and get medical help. Failure to do so will result in death or serious injury.

(000145)



⚠ DANGER

Electrocution. Turn battery disconnect OFF and de-energize REbus before touching terminals. Failure to do so will result in death, serious injury, equipment and property damage.

(000599)



⚠ DANGER

Electrocution. Verify electrical system is properly grounded before applying power. Failure to do so will result in death or serious injury.

(000152)

Safety Shutdown



⚠ DANGER

Electrocution. Initiate a system-wide safety shutdown and turn PWRcell Disconnect Switch OFF on all connected batteries before performing service. Failure to do so will result in death, serious injury, equipment and property damage.

(000600)

NOTE: A loss of grid power will not de-energize REbus in a system configured to island or provide backup power.

See [Figure 1-1](#). Shutdown button (A) on the Generac PWRcell Inverter control panel activates Safety Shutdown. Safety Shutdown signals connected devices to shutdown and limit output voltage to a safe level. An external shutdown button may also be installed, given appropriate labeling.

NOTE: An additional remote safety shutdown may be required to be installed for local compliance.

To enter Safety Shutdown, press and hold Shutdown (A). Safety shutdown LED (B) will illuminate and LCD screen (C) will indicate Safety Shutdown has been initiated.

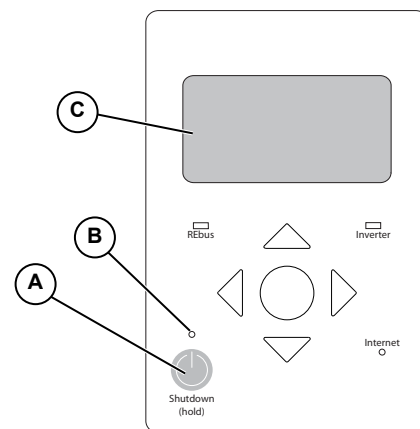

009918

Figure 1-1. Safety Shutdown Button (Located on Inverter Control Panel)

Upon entering Safety Shutdown, a shutdown signal will be transmitted to all devices connected to REbus. In Safety Shutdown:

- Generac PWRcell Inverter will disconnect from the grid.
- Generac PWRcell Inverter will stop sourcing power to REbus, and immediately disable all sources on REbus by sending a global shutdown signal.
- All Generac PV Link optimizers will disconnect their output.
- Safety Shutdown LED (B) will be illuminated to show that the inverter has entered safety shutdown. REbus DC bus voltage will be displayed on the inverter screen.

This page intentionally left blank.

Section 2: General Information

Specifications

Description	Units	X7600 Series	X11400 Series
Max. cont. AC power @ 50°C	kW	7.6	11.4
Grid Voltage	VAC	240 (1-ph)	120/208 (3-ph)
Max cont. REbus current (peak)	A	20	30
Max cont. grid output current	A	32	
AC terminals wire size	AWG	14 to 6	
DC terminals wire size	AWG	18 to 6	
STOP terminals wire size	AWG	28 to 16	
Gen Sense/Gen Start wire size	AWG	30 to 12	
Weight	lb (kg)	64 (29)	
Thermal management	-	forced convection	
Temperature range	°F (°C)	-4 to +122 (-20 to +50)	
Weatherization rating	-	NEMA 3R	
Enclosure Material	-	powder-coated steel	

Ratings

Description	Units	Min	Nominal	Max
Maximum Input Voltage (nanogrid)	V			420
Range of Input Operating Voltage (nanogrid)	V	360		400
Maximum input current (nanogrid)	A			20
Maximum input short circuit current (nanogrid)	A			30
Maximum input source backfeed current to input source (nanogrid)	A			30
Output power factor rating (AC)	-			1
Operating Voltage range (AC) 2ph	V, rms	108		130
Operating Voltage range (AC) 3ph	V, rms	106		132
Operating frequency range or single frequency	Hz	59.6		60.4
Nominal output voltage (AC)	V, rms		120/240 & 208V 3ph	
Normal output frequency (AC)	Hz		60	
Maximum continuous output current (AC)	A, rms			32
Maximum output overcurrent protection	A			50
Max output fault current and duration	A/ms		50 / 17	
Utility interconnection voltage and frequency trip limits and trip times	See Voltage and Frequency Trip Thresholds for more information.			
Trip Voltage Accuracy				
Trip Time Accuracy	-	2% +/-2 cycles		
Normal operation temperature range	°F (°C)	-4 (-20)		122 (50)
Output power temperature derating and maximum full power operating ambient	°F (°C)	-4 (-20)		122 (50)
Peak Efficiency	%			97.5
CEC Weighted Efficiency	%			97

Specifications are subject to change without notice. Refer to the product specification sheet for complete list.

Serial Number Location

Refer to **Figure 2-1** to locate unit serial number (A). Record the information from this tag in **Table 1: Generac PWRcell Inverter Important Information** on the inside front cover of this manual. When requesting assistance you may be asked to provide this information.

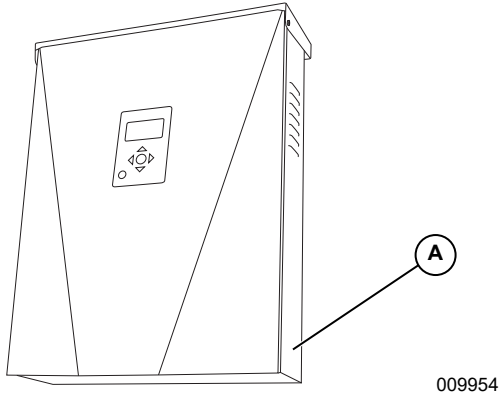

Figure 2-1. Serial Number Location

Unit Dimensions

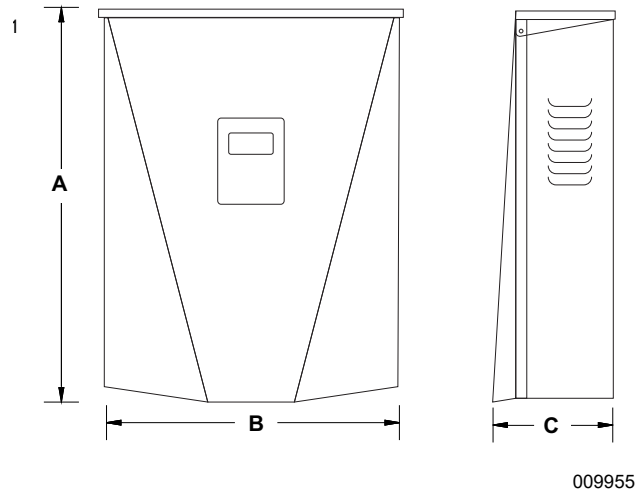

Figure 2-2. Unit Dimensions

A	24.5 in (622 mm)
B	19.25 in (489 mm)
C	8 in (203 mm)

About Generac PWRcell Inverters

The Generac PWRcell Inverter connects to the Generac PV Link™ and Generac PWRcell Battery to form the Generac PWRcell system for grid-interactive solar-plus-storage.

Upon the loss of grid power, Generac PWRcell Inverters disconnect from the grid and provide AC power to support protected loads when configured to do so.

All Generac PWRcell products use the REbus™ 380 VDC nanogrid to connect energy sources, storage, and loads. The REbus nanogrid automates the flow of power

to enable plug-and-play setup and operation of Generac PWRcell equipment. For more information about REbus, visit www.generac.com.

In **Figure 2-3** Generac PWRcell Inverter (E) is directly connected to Generac PV Link (B) and Generac PWRcell Battery (C) on DC (REbus) line (D). To the right of the inverter are AC lines: 120/240 VAC for grid and home loads (G), and protected loads (H) support up to 50 A.

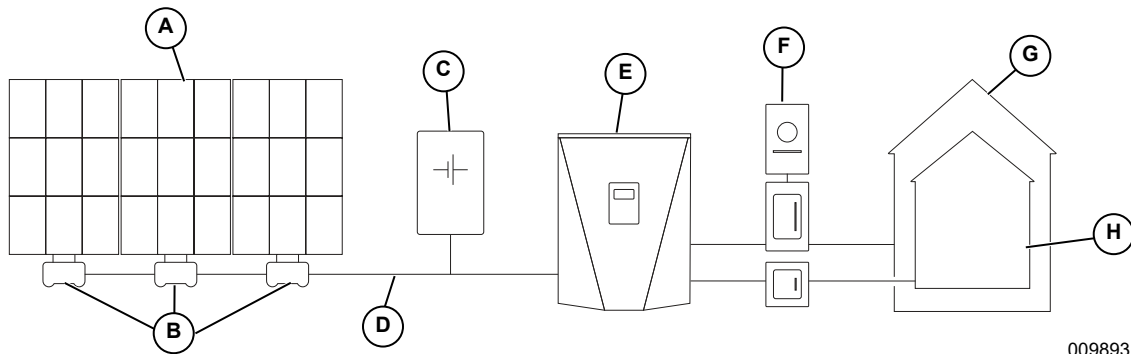

Figure 2-3. Generac PWRcell System Example

- | | |
|----------------------------------|-----------------------------------|
| A Solar Panels | E Generac PWRcell Inverter |
| B Generac PV Link | F Grid |
| C Generac PWRcell Battery | G Loads |
| D REbus | H Protected Loads |

Component Locations

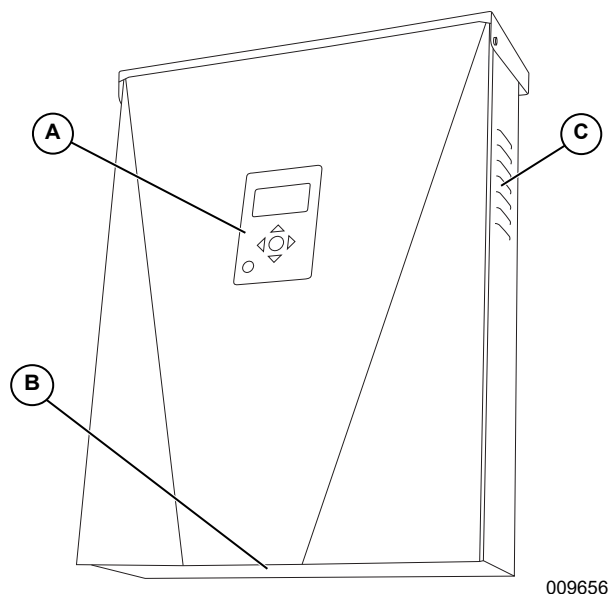

Figure 2-4. Component Locations

- A Control panel
- B Intake filter
- C Exhaust vent

Inverter Control Panel

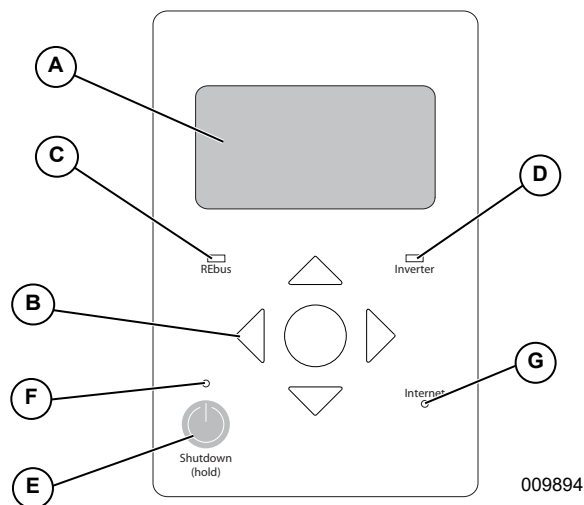

Figure 2-5. Inverter Control Panel

- A LCD display
- B Navigation keys
- C REbus status LED
- D Inverter LED
- E Safety Shutdown
- F Safety Shutdown LED
- G Internet LED

See [Figure 2-5](#). Generac PWRcell is controlled through the Generac PWRcell Inverter control panel. The inverter control panel is used for adjusting system settings and for interacting with devices.

LED Indicators

See [Figure 2-5](#) for LED locations.

REbus Status LED

REbus Status LED (C) communicates REbus nanogrid status through LED color.

- Green – all devices are functioning normally and are either generating power or ready to generate power.
- Yellow – no devices are connected or no devices are enabled.
- Red – one or more REbus device has a fault that requires attention before operation will continue.

NOTE: A red LED can also indicate a fault with the REbus nanogrid itself. See display (A) for more information about the specific fault detected.

Inverter LED

Inverter LED (D) communicates the status of the utility grid and/or inverter through LED color and state.

- Green – utility is connected and within normal operational voltage and frequency.
- Blinking green – system is in standby mode, powering up, or initializing.
- Yellow – utility grid is not within normal conditions, but user intervention typically is not required. The inverter will restart as soon as the utility grid returns to normal conditions.
- Red – a serious fault with the utility grid or inverter has been detected and user attention is required before the unit will resume operation. See display (A) for more information about the specific fault detected.
- No light – the inverter is disabled or powered off.

Safety Shutdown LED

Safety Shutdown LED (F) is illuminated when the system is in Safety Shutdown mode. Safety Shutdown may be initiated either from the Safety Shutdown button on the unit or an externally-installed shutdown switch. See [Safety Shutdown](#).

Internet LED

Internet LED (D) is illuminated when the inverter is connected to a router and has an IP address. See [Ethernet Configuration](#).

NOTE: A blue Internet LED does not mean that the inverter has connected with the Generac server.

This page intentionally left blank.

Section 3: Location and Compliance

Location

When installing the Generac PWRcell Inverter, consider the following:

- The unit can be installed in indoor or outdoor locations.
- The unit must be readily accessible.
- The inverter installation location must meet the working space requirements in NEC Article 110.26.

Compliance

⚠ DANGER

Loss of life. Property damage. Installation must always comply with applicable codes, standards, laws and regulations. Failure to do so will result in death or serious injury.

(000190)



⚠ WARNING

Electrocution. Refer to local codes and standards for safety equipment required when working with a live electrical system. Failure to use required safety equipment could result in death or serious injury.

(000257)

⚠ WARNING

Equipment damage. Only qualified service personnel may install, operate, and maintain this equipment. Failure to follow proper installation requirements could result in death, serious injury, and equipment or property damage.

(000182a)

Follow all instructions included in this manual and use appropriate practices for all product wiring and installation.

Note on DC Wiring and the NEC

Some electricians or installers may be unfamiliar with DC wiring in a residential setting. Note the following:

- NEC 690.31(G) for DC PV circuits in buildings
- NEC 215.12(C)(2) for correct DC wiring coloring
- NEC 210.5(C)(2) for identification of DC conductors carrying more than 50V

Always adhere to applicable codes when marking and installing DC conductors. See [Table 3-1: REbus DC Wiring Coloring Convention](#). Mark or flag all conductors as appropriate.

- It is recommended that REbus (+) conductors NOT be green, white, gray, blue, or black.
- It is recommended REbus (-) conductors NOT be green, white, gray, or red.

Table 3-1. REbus DC Wiring Coloring Convention

Wire	Color
REbus + (RE+)	Red
REbus - (RE-)	Black or Blue
Ground (GND)	Green or bare

Safety Shutdown

The Generac PWRcell Inverter is equipped with a safety shutdown function to help installers comply with the rapid shutdown requirements given in Article 690.12 of the National Electrical Code.

See [Safety Shutdown](#) for information on how to initiate and exit a shutdown.

See [External Safety Shutdown Switch](#) for information on installing and using an external safety switch to initiate a safety shutdown.

Voltage and Frequency Trip Thresholds

This unit or system is provided with fixed trip limits and shall not be aggregated above 30 kW on a single point of common connection.

All Generac PWRcell Inverters are shipped from the factory in compliance with all UL1741 requirements, including IEEE1547. If your installation requires compliance to a different standard, such as UL1741SA, contact the nearest Independent Authorized Service Dealer (IASD) or Generac Customer Service at 1-888-436-3722 (1-888-GENERAC), or visit www.generac.com for assistance.

Voltage Trip Thresholds

See [Table 3-2](#) for the default fixed voltage trip setpoints. All over voltage and under voltage trip conditions result in a 300-second restart delay time after the trip threshold has been exceeded for the listed number of cycles.

Frequency Trip Thresholds

See [Table 3-2](#) for the default fixed frequency trip setpoints. All over frequency and under frequency trip conditions result in a 300-second restart delay time after the trip threshold has been exceeded for the listed number of cycles.

Table 3-2. Voltage Trip and Frequency Thresholds

Voltage Trip Thresholds			Frequency Trip Thresholds		
Threshold	Threshold (% of nominal)	No. of Cycles	Threshold	Hz Over/ Under Nominal	No. of Cycles
OV1	110	120	OF1	0.5	120
OV2	120	10	OF2	2	6
OV3	130	1	OF3	1.3	0
OV4	999*	1	OF4	0**	1
UV1	88	120	UF1	0.5	120
UV2	50	10	UF2	2	10
UV3	0	1	UF3	0**	1
UV4	0	1	UF4	0**	1

*Value of 999 indicates a disabled threshold for voltage trips

**Value of zero indicates a disabled threshold for frequency trips

Section 4: Installing PWRcell Inverter

Mounting the Inverter



Equipment damage. Mount inverter to a strong, stable surface. Never mount to drywall, plaster, or other non-structural wall treatments. Failure to mount inverter to a strong, stable surface could result in equipment or property damage. (000641)

1. Verify mounting location adheres to the following requirements:
 - Inverter must be mounted upright on a vertical wall.
 - Mounting surface must be a strong, stable surface. Never mount to drywall, plaster or non-structural building finishes.
 - Fasteners must engage with at least two studs or other structural members.
 - Never obstruct intake or exhaust vents.
 - Never allow water to enter intake or exhaust vents.
 - See **Figure 4-1**. Observe all mounting clearances.

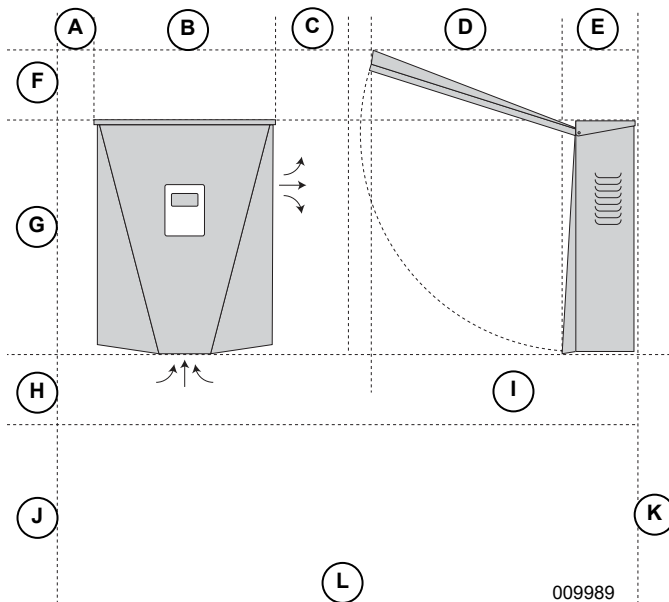

Figure 4-1. Mounting Clearances

A	4 in (101.6 mm)	G	24.5 in (622.3 mm)
B	19.25 in (489 mm)	H	8 in (203.2 mm)
C	8 in (203.2 mm)	I	28.5 in (723.9 mm)
D	20 in (508 mm)	J	28 in (711.2 mm)
E	8.5 in (215.9 mm)	K	36 in (914.4)
F	8 in (203.2 mm)	L	Floor

2. Verify fasteners are suitable for the mounting surface and can adequately secure the inverter to the wall. See **Specifications** for unit weight.
3. See **Figure 4-2**. Secure bracket (A) to mounting surface. Fasteners must engage at least two studs or other structural members.

NOTE: Mounting slots (B) accommodate different stud spacings.

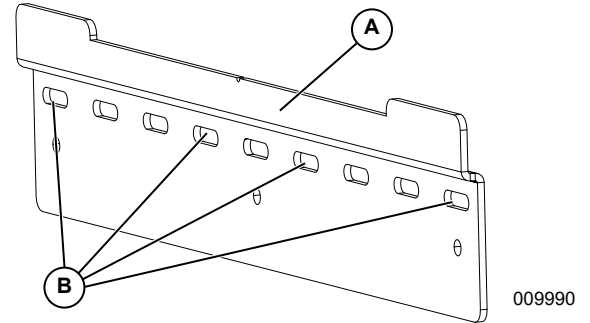

Figure 4-2. Installing Mounting Bracket

4. See **Figure 4-3**. Insert bracket tabs (C) into inverter body slot (D).

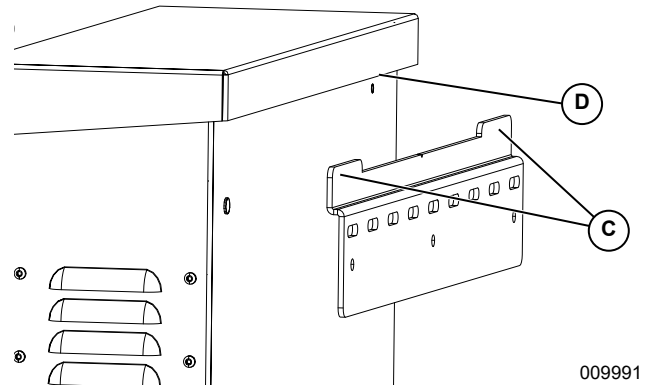

Figure 4-3. Mounting Inverter onto Bracket

5. See **Figure 4-4**. Secure inverter to wall with two fasteners through mounting holes (E).

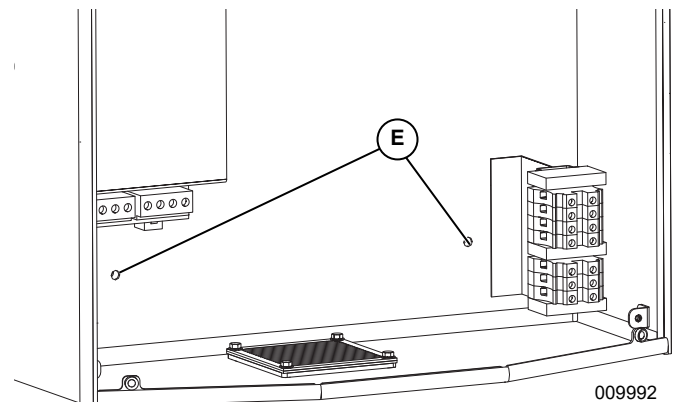

Figure 4-4. Mounting Holes

This page intentionally left blank.

Section 5: Electrical Connections

Generac PWRcell Inverter Wiring Compartment

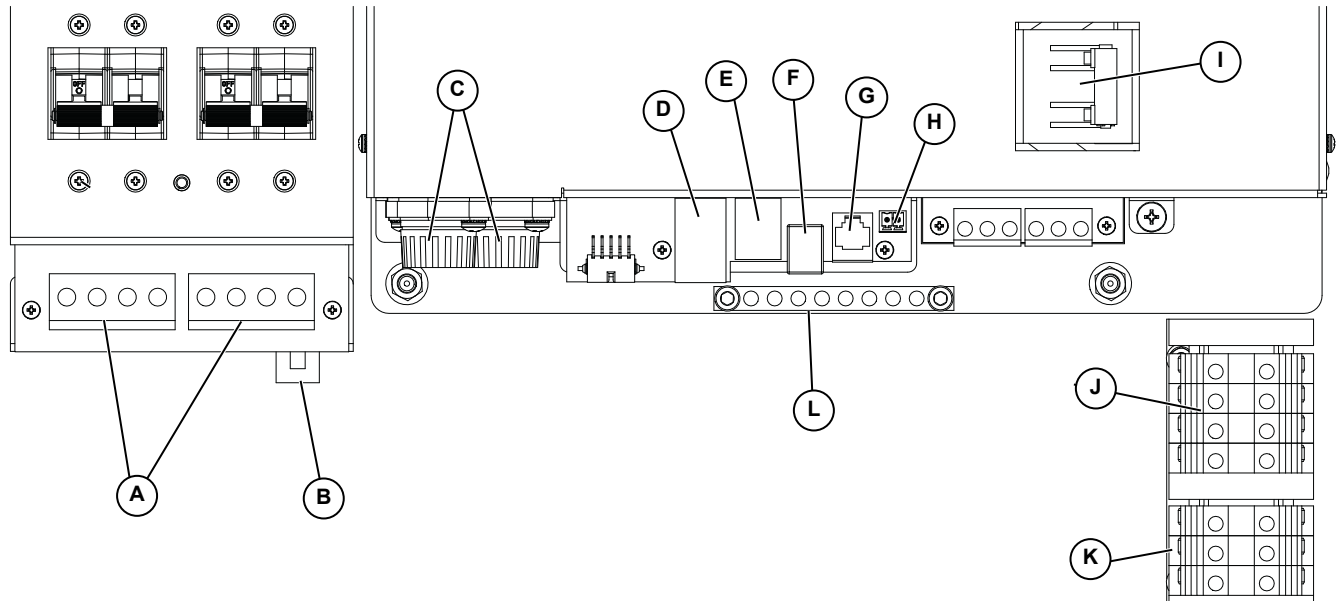

Figure 5-1. Generac PWRcell Inverter Wiring Compartment

- | | |
|---|--|
| A REbus bi-directional DC terminals | G Authorized Generac personnel only |
| B Internet connection | H REbus Beacon port |
| C DC main fuses | I Protected loads breaker |
| D Current Transformers (CTs) accessory port | J AC grid connection terminals |
| E Automatic Transfer Switches (ATs) accessory port | K Protected loads terminals |
| F External safety shutdown switch terminal | L Grounding bar |

Accessing Wiring Compartment



⚠ DANGER

Electrocution. Initiate a system-wide safety shutdown and turn PWRcell Disconnect Switch OFF on all connected batteries before performing service. Failure to do so will result in death, serious injury, equipment and property damage. (000600)



⚠ DANGER

Electrocution. Verify all system voltages are safe before wiring. Disconnect all AC and DC sources of power before touching terminals. Failure to ensure no dangerous voltages are present on conductors and terminals before wiring will result in death or serious injury. (000642)

To access the wiring compartment:

1. Initiate a Safety Shutdown and allow DC voltage to drop to a safe level.
2. Power down inverter
3. Disconnect all sources of AC and DC Power.
4. See [Figure 5-2](#). Open inverter front cover by lifting the bottom to horizontal (A) and pushing inward (B).

5. Locate wiring compartment cover (C).
6. Remove five M4X10 screws (D) and wiring compartment cover.

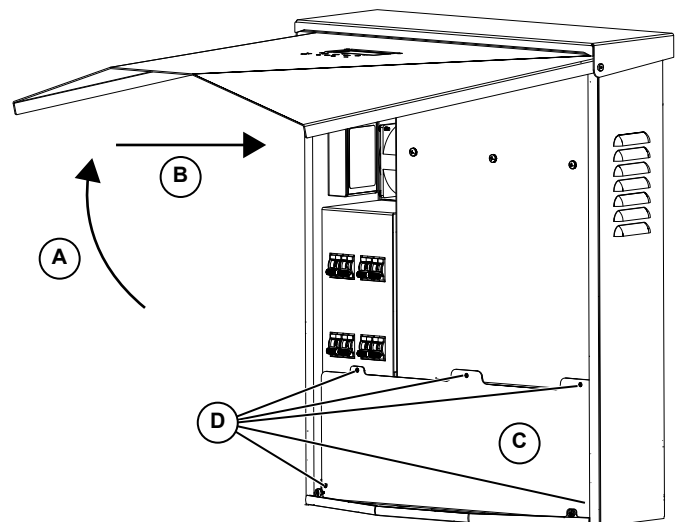

009994

Figure 5-2. Wiring Compartment

Knockout Dimensions and Locations

NOTE: All knockouts are combination knockouts.

See **Figure 5-3** for knockout locations and **Table 5-3** for available knockout sizes and quantities.

When using knockouts:

- Install reducing washers to accommodate smaller conduit sizes.
- Install rain-tight or wet locations hubs in compliance with UL514B.

Table 5-3. Combination Knockout Size and Quantity

Combination Knockout Size	Quantity
3/4" X 1"	6
1/2" X 3/4"	7

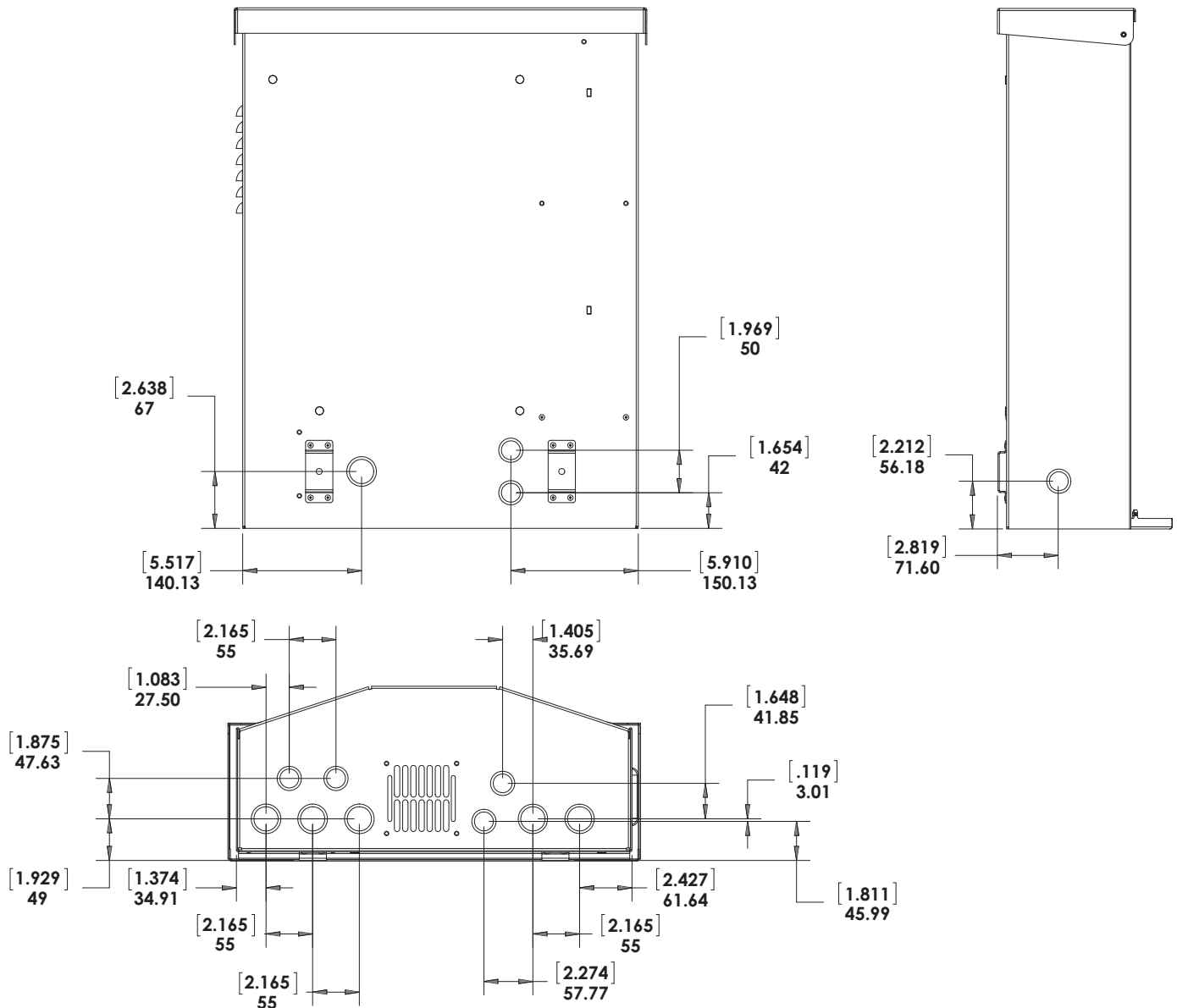

009995

Figure 5-3. Knockout Locations

Wiring Guidelines



⚠ DANGER

Electrocution. Verify all system voltages are safe before wiring. Disconnect all AC and DC sources of power before touching terminals. Failure to ensure no dangerous voltages are present on conductors and terminals before wiring will result in death or serious injury. (000642)



⚠ DANGER

Electrocution. Turn battery disconnect OFF and de-energize REbus before touching terminals. Failure to do so will result in death, serious injury, equipment and property damage. (000599)

- The inverter shall be installed in accordance with NEC Article 705.
- Proper installation techniques must be employed to restrain service loops and to separate AC, DC and isolated circuits.
- All conductors must be rated for at least 420 V.
- Always use wiring methods in accordance with National Electrical Code (ANSI/NFPA 70) or other applicable codes.
- Field terminals are for copper conductors only.
- Do not use field wiring leads smaller than 18 AWG.
- All permanently-installed conductors within the unit are sized in compliance with NEC Table 310.15(B)(16) (formerly Table 310.16).
- Torque all terminals as specified in [Table 5-4](#).

Table 5-4. Terminal Toques

Wiring Terminal	Torque
AC terminals	13.3 to 15.9 in-lb (1.5 to 1.8 Nm)
DC terminals	12 in-lb (1.35 Nm)
Ground terminals	4 to 6 AWG: 45 in-lb (5 Nm) 8 AWG: 40 in-lb (4.5 Nm) 10 to 14 AWG: 35 in-lb (4 Nm)
STOP terminals	1.9 to 2.2 in-lb (0.22 to 0.25 Nm)

Grounding Bar Wiring

⚠ WARNING

Equipment damage. Never connect REbus conductors to ground. Connecting REbus conductors to ground could result in equipment or property damage.

(000643)

- The grounding bar provides central grounding for up to 8 conductors.
- Input and output circuits are isolated from the enclosure.
- The utility neutral conductor is not bonded to the equipment ground terminal bar within the enclosure.
- The inverter shall be installed as a non-separately derived system.
- System grounding is critical for REbus communications. Bond the inverter enclosure to the equipment grounding conductor of the normal power source power feeder. Properly bond the following equipment to the inverter equipment grounding terminal bar:
 - PV arrays
 - Generac PV Link
 - Generac PWRcell Batteries
- Torque all terminal as specified in [Table 5-5](#).

Table 5-5. Grounding Bar Wiring Terminal Specifications

Wire Size (AWG)	Torque
4-6	45 in-lb (5 Nm)
8	40 in-lb (4.5 Nm)
10	30 in-lb (4 Nm)

DC Wiring

⚠ WARNING

Equipment damage. Connect only to REbus-compatible devices to the DC bus. Never connect to any other DC power source. Connecting to other DC power sources could result in equipment damage.

(000598)

⚠ WARNING

Equipment damage. Do not connect PV string output directly to inverter. PV must be connected via Generac PWRcell PV Link. Connecting PV output directly to inverter could result in equipment or property damage.

(000644)

⚠ WARNING

Equipment damage. Do not connect raw, unregulated battery output to inverter. Connect only REbus-compatible batteries. Connecting batteries that are not REbus-compatible could result in equipment or property damage.

(000645)

⚠ WARNING

Equipment damage. Obey polarity markings when connecting REbus devices. Reverse-polarizing DC circuits could result in equipment or property damage.

(000646)

⚠ WARNING

Equipment damage. Connect only one wire to each DC wiring terminal. Doubling wires on a terminal could result in equipment or property damage.

(000647)

NOTE: Disable REbus before returning breakers to ON position.

- Connect all REbus devices to the REbus bi-directional DC terminals.
- Each terminal is protected by a 30 A two-pole circuit breaker.
- Breakers indicate state and may be used to disconnect DC circuits.
- Breakers disconnect both ungrounded DC conductors simultaneously.
- Torque all terminals as specified in [Table 5-6](#).

Table 5-6. DC Wiring Terminal Specifications

Wire Size	Terminal Temp Range	Wire Min Temp Rating	Torque
18-6 AWG (.75-10 mm)	-40 to 266°F (-40 to 130°C)	194°F 90°C	12 in-lb (1.35 Nm)

AC Wiring

NOTE: The installer is responsible for providing sufficient overcurrent protection for the AC grid wiring terminals. The conductors and overcurrent protection device shall be sized in accordance with NEC Article 705.12 for the utility power connection. All other conductors shall be sized in accordance with NEC Table 310.15(B)(16) and all other applicable NEC Articles.

- See [Figure 5-4](#). The Generac PWRcell inverter is equipped with four AC grid connection terminals and three protected loads terminals.
- Use the top four terminals (A) for connection to the utility grid.

NOTE: Use L3 terminal (B) with 3-phase inverters only.

- Use the bottom three terminals (C) for protected loads output. See [Protected Load](#).

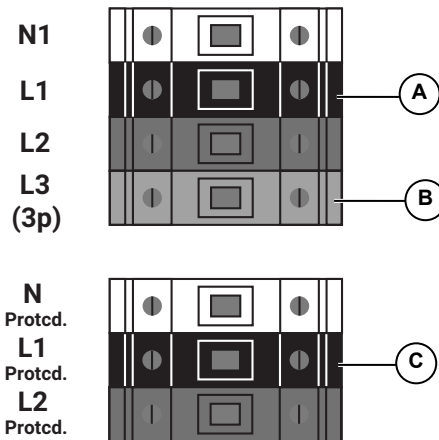

009994

Figure 5-4. AC Wiring Terminals

- Torque all terminals as specified in [Table 5-7](#).

Table 5-7. AC Wiring Terminal Specifications

Wire Size	14 to 6 AWG (2.08 mm ² to 16 mm ²)
Terminal Temp Range	Up to 248°C (120°C)
Wire Min Temp Rating	194°F (90°C)
Torque	13.3 in-lb to 15.9 in-lb (1.5 Nm to 1.8 Nm)

Protected Load

WARNING

Equipment damage. Never connect protected loads terminals to other sources of power, including any other inverter, the utility grid, or a generator. Doing so could result in equipment or property damage. (000648)

WARNING

Equipment damage. Never connect protected loads output from multiple inverters in parallel. Doing so could result in equipment or property damage. (000649)

NOTE: The protected loads terminals cannot provide full three-phase power.

For systems equipped with energy storage, the protected loads terminals provide power during a grid outage.

See **Figure 5-5**. By default, the grid powers any protected loads connected to the inverter protected loads terminals. During a grid outage, internal relays inside the inverter isolate the AC grid connection and the inverter powers the protected loads only using PV array and battery power. This transition takes place in a fraction of a second.

NOTE: To create a protected loads panel, connect the circuits that require backup to a subpanel. Connect this subpanel to the protected loads terminals.

- The protected loads continuous output is 8 kW or 33.3 amps at 240V.
- The inverter can surge up to 50 A for motor starting capabilities.

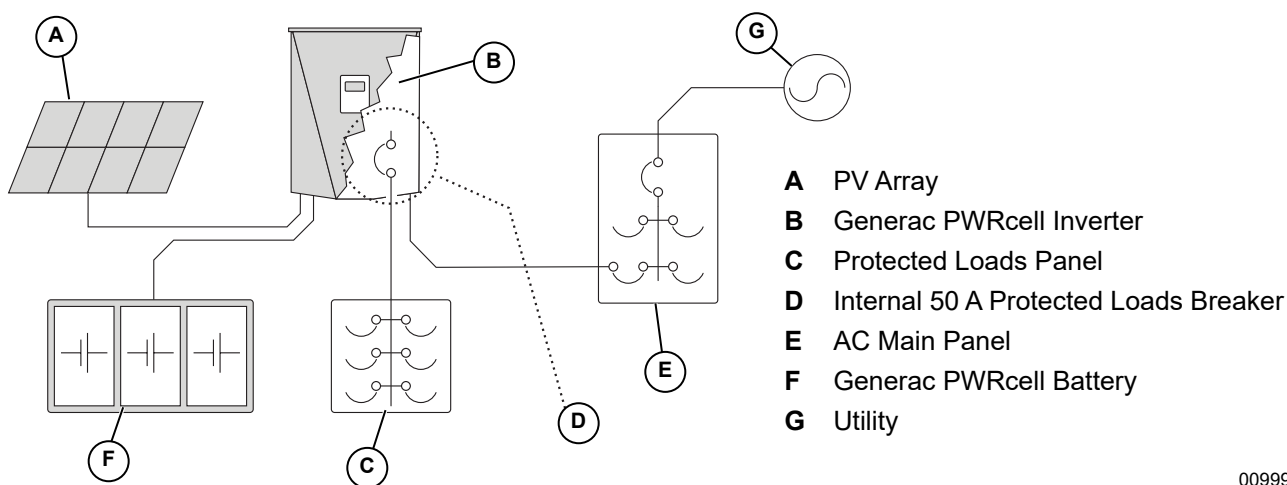

009997

Figure 5-5. Single Inverter Backup Installation with Protected Loads Panel

NOTE: See **Figure 5-6**. On systems that do not include battery storage but battery storage is expected in the future, install a protected loads panel during inverter installation. The protected loads panel will be fed by the grid while the system operates in Grid Tie mode.

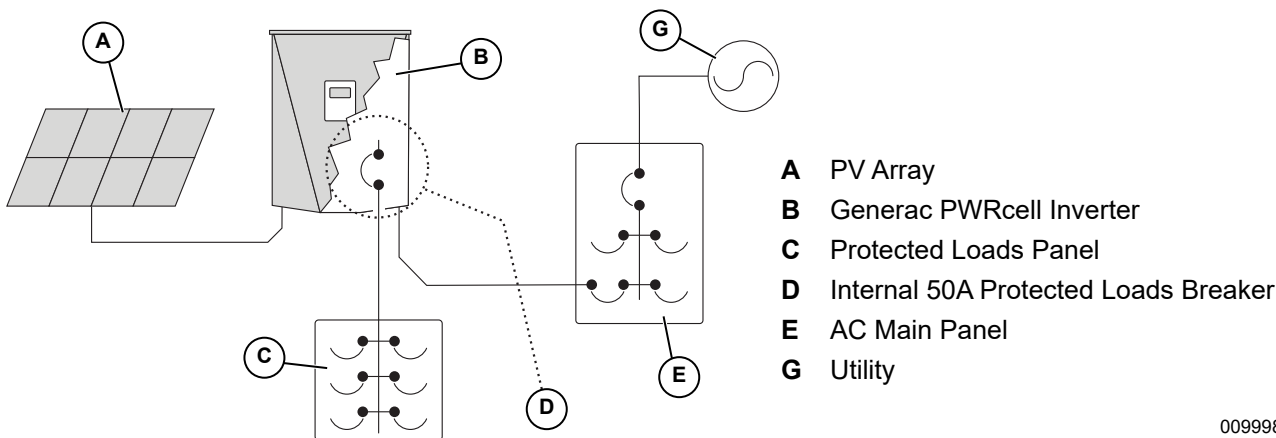

009998

Figure 5-6. Configuration for Adding Batteries Later

Connecting Ethernet

IMPORTANT NOTE: Generac requires all PWRcell system components to be connected to the Internet and to maintain such connection throughout the warranty period. Internet connectivity is established via the PWRcell Inverter. By installing the PWRcell Inverter and connecting it to the Internet, Customer agrees that Generac may remotely monitor the use and condition of the system and update the system's software and firmware, as necessary, without further notice. If the PWRcell system loses Internet connection for an extended period, Generac may not be able to provide important remote upgrades. In such cases, Generac may not be able to honor the full warranty.

- See **Generac PWRcell Inverter Wiring Compartment** for the Inverter Ethernet jack location.
- Use an appropriate cord grip or strain-relief connector when running Ethernet cable with a conduit.
- Inverters connected by a router to a DHCP network will automatically detect settings.
- For manual IP setup, see the Generac PWRcell Inverter Owner's Manual.

NOTE: It is the installer's responsibility to verify the Internet connection is reliable and secure. Generac recommends using a hardwired connection to provide Internet connectivity. Generac does not support using any wireless or power line carrier network devices. Use these devices at your own discretion.

Current Transformers (CTs)

Current transformers (CTs) are required to use the Self Supply mode and to enable Zero Export capability. CTs also allow the inverter to provide information on utility consumption through the Generac PWRcell Inverter control panel and the PWRview monitoring app.

Connecting Current Transformers

- See **Figure 5-7**. Install CTs around the main service conductors between the service meter and point of interconnection with subsequent service entrance panel/device.
- Install one current transformer per phase:
 - Install two CTs for split phase grids.
 - Install three CTs for three-phase grids.

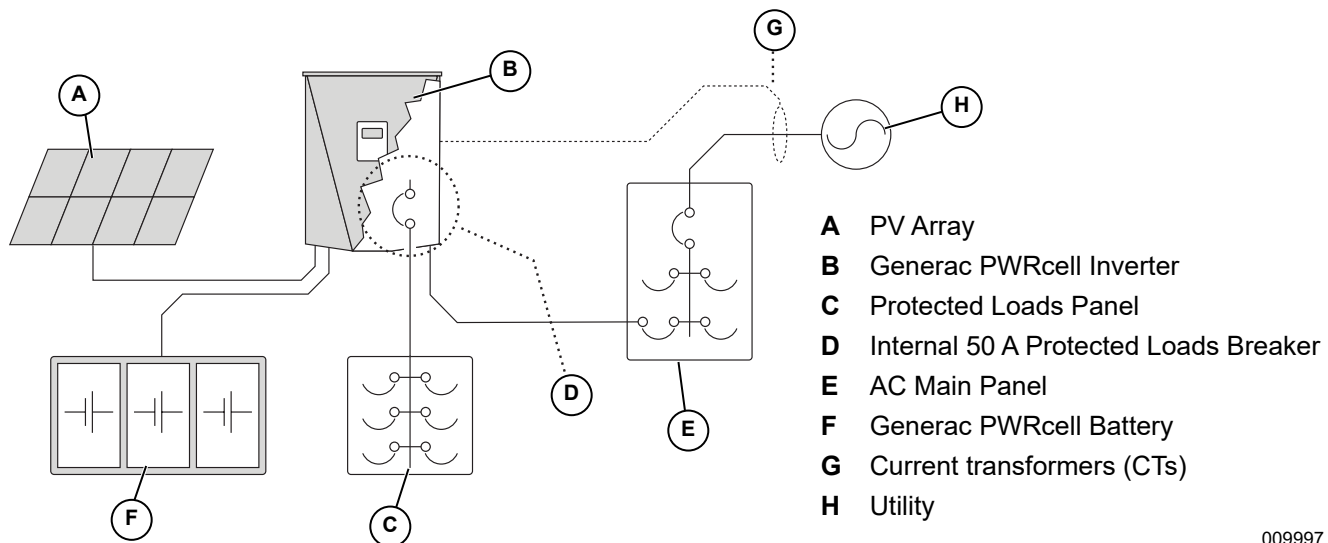

009997

Figure 5-7. Connecting Current Transformers (CTs)

Connecting CTs to the Inverter

- See **Figure 5-8**. Connect CTs to the inverter using a RJ-45 connector and Category 5 (Cat 5) Ethernet cable.
- CT input jack (H) is a double-stacked RJ-45 jack. Either the top or bottom jack may be used.

NOTE: Connect CTs to the CT input jack in the middle of the wiring compartment. Do not connect CTs to the Ethernet jack. Do not connect the Internet to the CT input jack. See **Generac PWRcell Inverter Wiring Compartment** for jack locations.

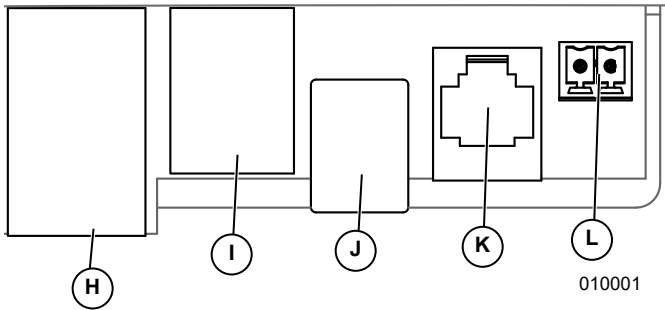

Figure 5-8. Accessory Ports

- H** CTs RJ-45 jack
- I** ATS (Automatic Transfer Switch) RJ-45 jack
- J** REbus Beacon USB-B
- K** Authorized Generac personnel only
- L** External safety shutdown switch terminals

- See **Figure 5-9**. Connect CT leads to RJ-45 Breakout Adapter (M), using the wire coding shown in **Table 5-8: CT Pinout**.

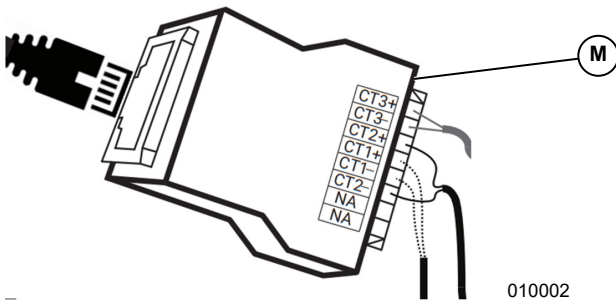

Figure 5-9. RJ-45 Breakout Adapter

NOTE: RJ-45 Breakout Adapter is included in the Generac PWRcell Kit.

NOTE: If the RJ-45 Breakout Adapter is not available, the CT leads can be wired to a Cat 5 cable.

Table 5-8. CT Pinout

Pin	Wire Color (T-568A)	Wire Color (T-568B)	Value
1	White/Green	White/Orange	CT3+
2	Green	Orange	CT3-
3	White/Orange	White/Green	CT2+
4	Blue	Blue	CT1+
5	White/Blue	White/Blue	CT1-
6	Orange	Green	CT2-
7	White/Brown	White/Brown	Not Used
8	Brown	Brown	Not Used

CT Calibration

- Install CTs before powering ON the inverter.
- The inverter automatically detects and calibrates CTs when turned ON.
- Once CTs are detected and calibrated, a utility pole symbol will appear on the lower right corner of the home screen power flow diagram.
- If manual CT calibration is required, set CalOverride to 1. The CalOverride setpoint is accessible through the Mod. Settings menu via the inverter device page. See **Table 5-9** for more information.
 - CT1 must be connected to Line 1.
 - CT2 must be connected to Line 2.
 - CT3 must be connected to line 3 (for three phase applications).
 - All CTs must be pointed such that positive current defined by the arrow of the CT is pointed towards the grid.

Table 5-9. CT Setpoints

Setpoint	Behavior	Default	Units
C	<ul style="list-style-type: none"> • Overrides automatic CT detection. • When set to 0, the inverter automatically detects the CTs number and direction of CTs. • A value of 1 assumes a specific orientation and direction of CTs. 	0	N/A
CTTurnsRatio	<ul style="list-style-type: none"> • Turns ratio of the CTs installed. • Default turns ratio of 1500 is compatible with included clamp type CT's • If installation restriction requires larger accessory CT's, set point shall be adjusted to 3000. 	1500	Turns

Table 5-10. Automatic Detection Troubleshooting Table

Event Name	Event Code	Description	Possible Solution
ct cal = 1	0x8061	Line 1 doesn't have a valid CT calibration	Check wiring and CT integrity
ct cal = 2	0x8062	Line 2 doesn't have a valid CT calibration	Check wiring and CT integrity
ct cal = 3	0x8063	Line 1 & 2 don't have a valid CT calibration	Check wiring and CT integrity
ct cal = 4	0x8064	Line 3 don't have a valid CT calibration	Check wiring and CT integrity
ct cal = 5	0x8065	Line 1 & 3 don't have a valid CT calibration	Check wiring and CT integrity
ct cal = 6	0x8066	Line 2 & 3 don't have a valid CT calibration	Check wiring and CT integrity
ct cal = 7	0x8067	Line 1 & 2 & 3 don't have a valid CT calibration	Check wiring and CT integrity
ct cal = 9	0x8069	Line 1 has multiple CTs on it (or a CT is on the neutral wire)	Check wiring and CT integrity
ct cal = A	0x806A	Line 2 has multiple CTs on it (or a CT is on the neutral wire)	Check wiring and CT integrity
ct cal = B	0x806B	Lines 1 and 2 have multiple or missing CTs on them (or a CT is on the neutral wire)	Check wiring and CT integrity
ct cal = C	0x806C	Line 3 has multiple CTs on it (or a CT is on the neutral wire)	Check wiring and CT integrity
ct cal = D	0x806D	Lines 1 & 3 have multiple or missing CTs on them (or a CT is on the neutral wire)	Check wiring and CT integrity
ct cal = E	0x806E	Lines 2 & 3 have multiple or missing CTs on them (or a CT is on the neutral wire)	Check wiring and CT integrity
ct cal = F	0x806F	Lines 1 & 2 & 3 have multiple or missing CTs on them (or a CT is on the neutral wire)	Check wiring and CT integrity
ct cal success	0x8070	Calibration was successful	Check wiring and CT integrity

Other Accessories

External Safety Shutdown Switch

NOTE: Select an appropriately rated, code compliant switch. Local codes may require special labeling, indicators, or other features. Requirements can vary by region, so consult a local code enforcement officer for guidance.

- If an external safety shutdown switch is required, the switch must be a closed (NC) type switch or button.
- See [Figure 5-10](#). Connect the external safety shutdown switch to stop terminals (B).

NOTE: The stop terminals ship with a jumper installed. Remove this jumper before installing an external switch.

- Installation of an external switch does not disable the switch mounted on the front control panel. Either the front panel button or the external switch may be used to initiate a Safety Shutdown. However, once a shutdown has been initiated, the front control panel must be used to exit the shutdown. If a locking-type switch is installed, the system cannot exit the Safety Shutdown until the switch has been released.

Tech. Service Connection

Service RJ-11 jack (C) is for use authorized Generac personnel only. Never connect any device to this jack without direct instructions from Generac Technical Service.

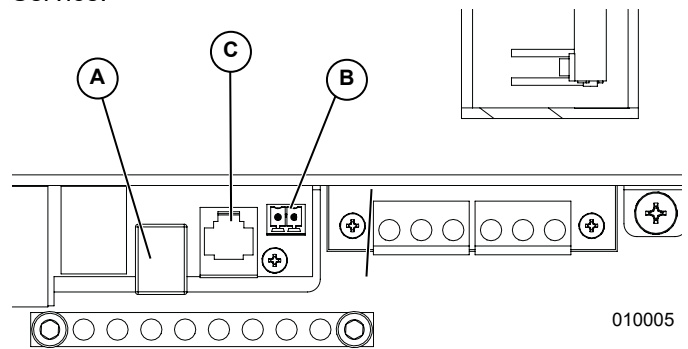

Figure 5-10. Accessory Ports

- A** REbus Beacon USB-B jack
- B** External Safety Shutdown terminal
- C** Authorized Generac personnel only

Section 6: Commissioning and Setup

System Configuration

The Generac PWRcell system is a flexible, highly customizable system that can be configured in a number of ways to meet customer need. Correct system configuration requires selecting the right equipment and the correct operational mode for the system. See the Generac PWRcell Inverter Owner's Manual for information on operational modes and other user-configurable settings.

Enabling Islanding

Systems with the Generac PWRcell Battery must have the Enalnding setpoint set to ON to island. This setpoint is accessible through the Mod. Settings menu via the inverter device page. See the Generac PWRcell Inverter Owner's Manual for information on accessing and adjusting the Enalnding setpoint.

General Information

All REbus devices are configured and controlled through the Generac PWRcell Inverter. Connected devices will appear on the LCD display.

Commissioning the System

NOTE: See the Generac PWRcell Commissioning Quick Start Guide for more information.

Commissioning consists of five steps:

1. ***Inverter Power-up***
2. ***Selecting an Operational Mode***
3. ***Configuring Custom Grid Settings (optional)***
4. ***Enabling REbus Devices***
5. ***Enabling Generac Beacon***

Before powering up the system for the first time:

- Verify AC voltage is within the specified range for system configuration.
 - 240 V split-phase
 - 208 V 3-phase
- Verify all wiring terminations are tight and secure.
- Verify DC wiring field terminations are secure and polarity is correct.
- Verify DC breakers for all connected devices are turned ON.

Inverter Power-up

Turn ON the main AC breaker to power-up the inverter.

See **Figure 6-1**. On power-up, the home screen will appear on the control panel LCD with the operational mode listed at the top of the home screen.

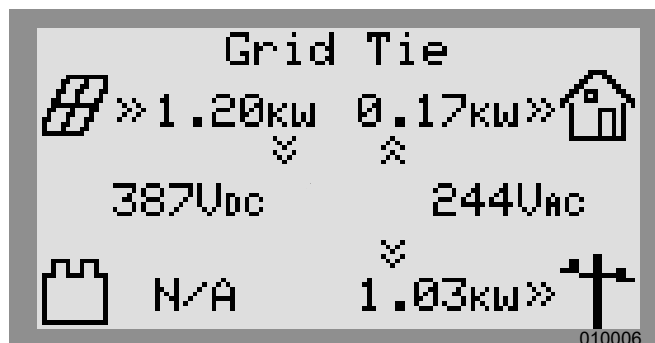

Figure 6-1. Inverter Power-Up

NOTE: If there is no grid power at the site and the system includes Generac PWRcell Battery, blackstart can be used to start the system from the battery. See the Generac PWRcell Owner's manual for information on blackstarting a system.

Selecting an Operational Mode

NOTE: See the Generac PWRcell Inverter Owner's Manual for more information on operational mode options.

To select an operational mode:

1. See **Figure 6-2**. While viewing the home screen press the center button.

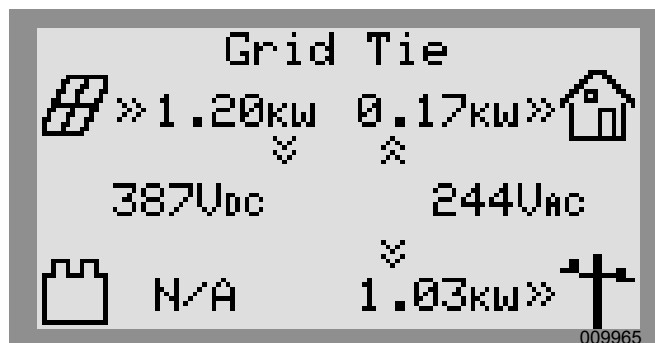

Figure 6-2. Selecting Operational Modes (1 of 4)

- See **Figure 6-3**. A list of operational modes will be displayed with the current mode marked with an asterisk.

NOTE: The list of modes may not include all those shown in **Figure 6-3**.

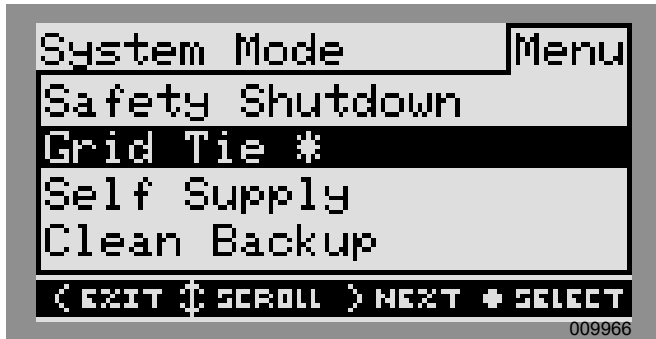

Figure 6-3. Selecting Operational Modes (2 of 4)

- See **Figure 6-4**. Use the up and down arrows to highlight the desired mode and press the center button to select.

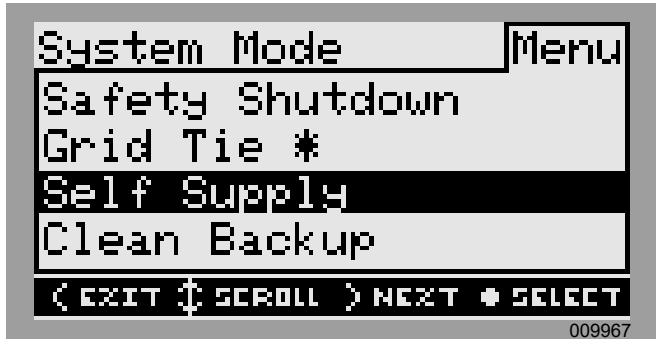

Figure 6-4. Selecting Operational Modes (3 of 4)

- Arrow right and press the center button to select Confirm.
- See **Figure 6-5**. Verify the mode listed at the top of the home screen is the desired mode.

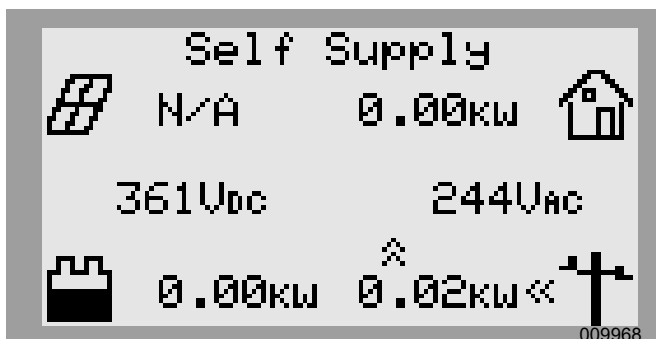

Figure 6-5. Selecting Operational Modes (4 of 4)

Configuring Custom Grid Settings (optional)

By default, all Generac PWRcell Inverters ship in compliance with UL1741, including IEEE1547. If the system needs to be configured to comply with a different grid interconnection standard, activate the new configuration before proceeding.

Enabling REbus Devices



DANGER

Electrocution. Never enable any device during an installation or while wires are exposed. Doing so could result in death, serious injury, equipment or property damage.

(000627)

NOTE: All Generac PWRcell devices are enabled and configured individually through the Generac PWRcell Inverter control panel.

Following installation, the inverter must be enabled before all other REbus devices.

To enable the inverter:

- See **Figure 6-6**. Use the right arrow key to scroll the inverter device page.
- Verify inverter status reads disabled.

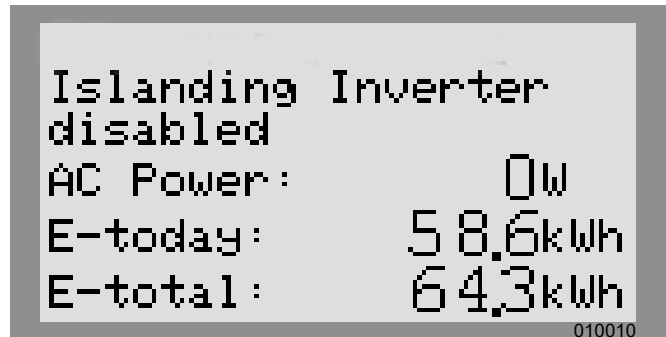

Figure 6-6. Enabling Inverter (1 of 4)

- Press the center button.
- See **Figure 6-7**. Highlight Enable and press the center button.



Figure 6-7. Enabling Inverter (2 of 4)

- See [Figure 6-8](#). Arrow right and press center button to Confirm.

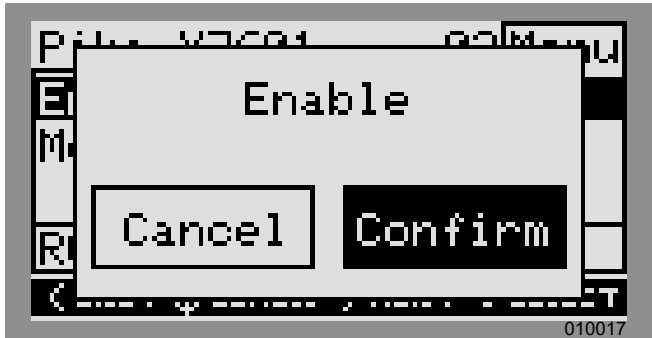

Figure 6-8. Enabling Inverter (3 of 4)

- See [Figure 6-9](#). The inverter is enabled. It will create voltage at the DC terminals and begin communicating over REbus.

NOTE: Per UL1741, the Generac PWRcell Inverter may wait five minutes or longer before beginning to export power after the inverter has been enabled.

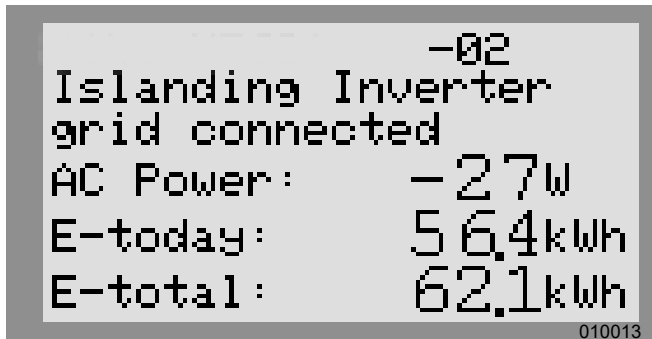

Figure 6-9. Inverter Enabled (4 of 4)

- Enable all other Rebus devices connected to the system by repeating steps 1-5 for each device.

NOTE: If the system includes battery storage, islanding must be enabled to allow the inverter to provide power during grid outages. See [Enabling Islanding](#) for more information.

Generac REbus Beacon Setup

Generac REbus Beacon allows the Generac PWRcell system to manage energy production and storage over the course of the day. This is called Time of Use (TOU) energy management. To take advantage of this functionality, Generac PWRcell must include a Generac PWRcell battery and a reliable connection to the Internet via an Ethernet connection to a router. See [Ethernet Setup](#) for more information.

Configuring and Running a TOU Schedule

- See [Figure 6-10](#). Navigate to the Generac Beacon device page and press the center button to enter the device menu.

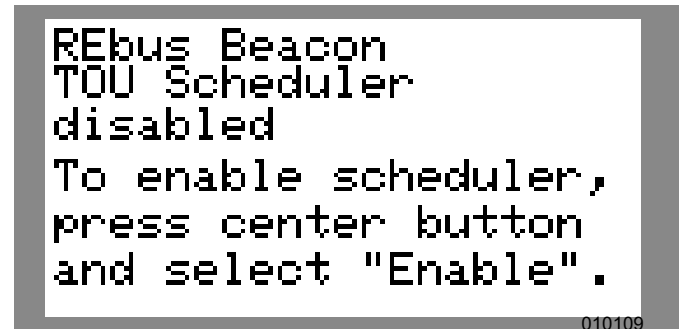

Figure 6-10. Configuring TOU Schedule (1 of 4)

- See [Figure 6-11](#). Use the up and down arrows to highlight Mod. Settings and press the center button to enter the settings menu.

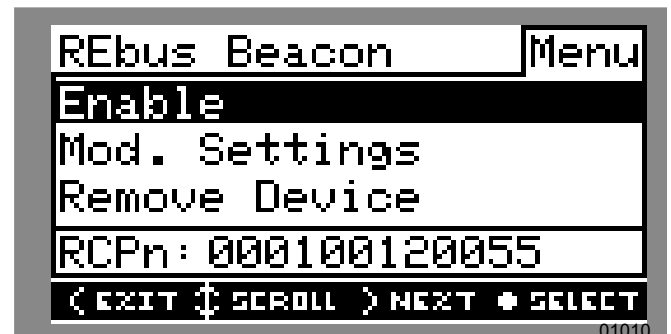

Figure 6-11. Configuring TOU Schedule (2 of 4)

- See [Figure 6-12](#). Use the up and down arrows to highlight Access Code and press the center button to select.
- Use the up and down arrows to set the Access Code to 57, and press the center button.

NOTE: The access code is valid for five minutes. After five minutes, the access code must be entered again to enable changes.

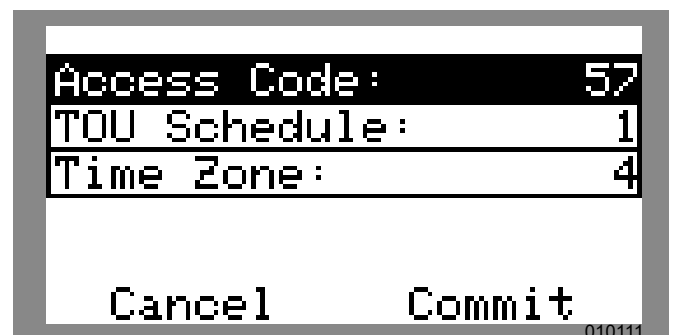

Figure 6-12. Configuring TOU Schedule (3 of 4)

5. Use the up and down arrows to highlight TOU Schedule and press the center button to select.
6. Use the up and down arrows to adjust the TOU Schedule. Once the desired value is set, press the center button to exit edit mode.

NOTE: See the latest Time of Use Program Guide for current TOU schedule values. The program guide is available at www.generac.com.

7. Set the Time Zone to the desired location based on [Table 1: Time Zone Codes](#). Once the desired value is set, press the center button to exit edit mode.

Table 1 - Time Zone Codes

Time Zone	Units
UTC	0
US/Eastern	1
US/Central	2
US/Mountain	3
US/Pacific	4
US/Alaska	5
US/Hawaii	6

8. See [Figure 6-13](#). To commit changes to all entries, highlight Commit. Press the center button, then use the arrows and center button to confirm the choice.

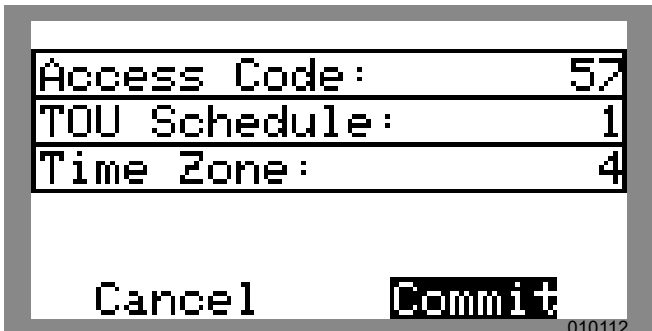

Figure 6-13. Configuring TOU Schedule (4 of 4)

See [Figure 6-14](#) and [Figure 6-15](#). When enabled, the LCD will alternate between a TOU Scheduler Running Screen and a Current Operational Mode screen. Both screens will display the time until the next system change and the mode the system will change to. The TOU Schedule name will be listed at the bottom of the device page.

See [Figure 6-16](#) and [Figure 6-17](#). On the home page, the text above the power flow diagram will alternate between Scheduler Active and the current operational mode.

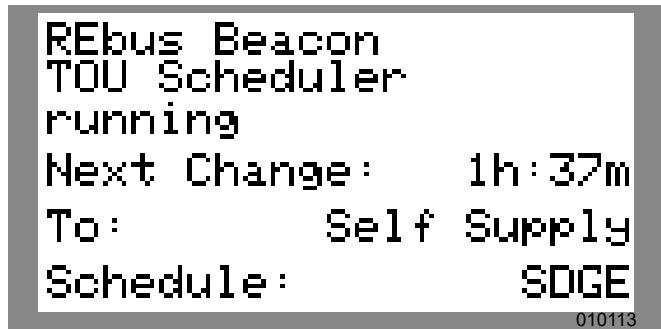

Figure 6-14. Running

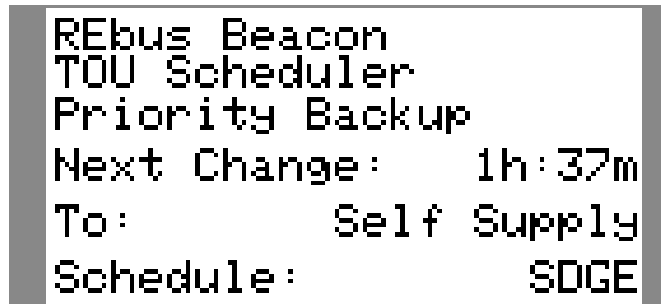

Figure 6-15. Current Operational Mode

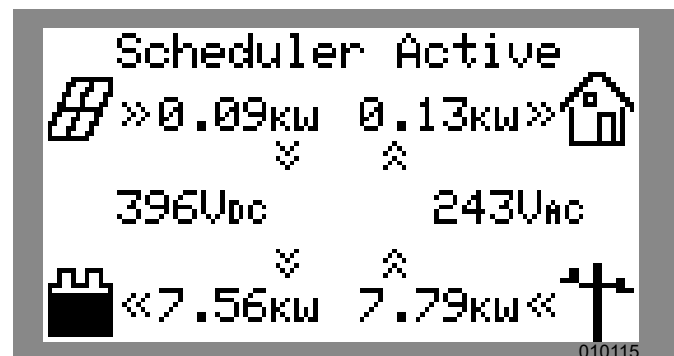

Figure 6-16. Scheduler Active

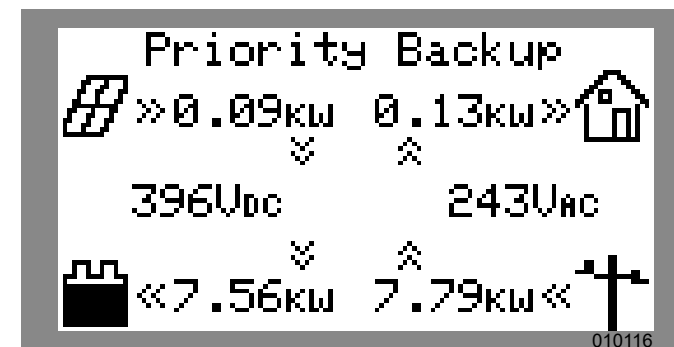

Figure 6-17. Current Mode

Disabling Generac Beacon

The scheduler can be disabled at any time. To disable the scheduler:

1. See [Figure 6-18](#). Navigate to the Generac Beacon device page and press the center button to enter the device menu.

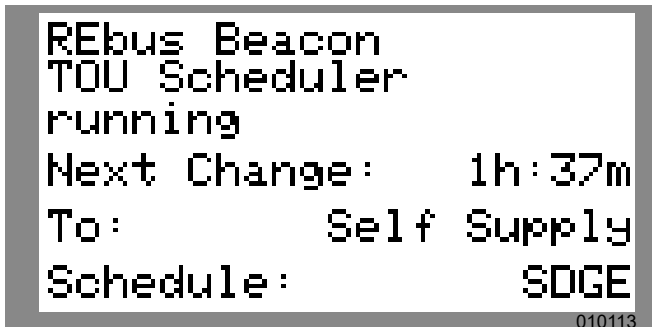

Figure 6-18. Disabling Beacon (1 of 3)

2. Highlight Disable and press the center button.
3. See [Figure 6-19](#). Arrow sideways to Confirm and press the center button.

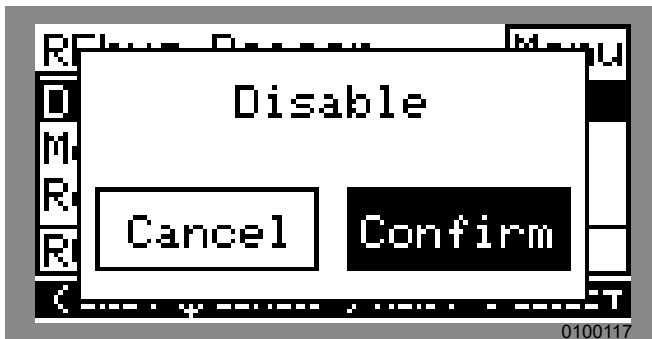

Figure 6-19. Disabling Beacon (2 of 3)

4. See [Figure 6-20](#). The status line on the Generac Beacon device page will read Disabled.

NOTE: The system will remain in the current operational mode until the mode is changed manually or the scheduler is re-enabled.

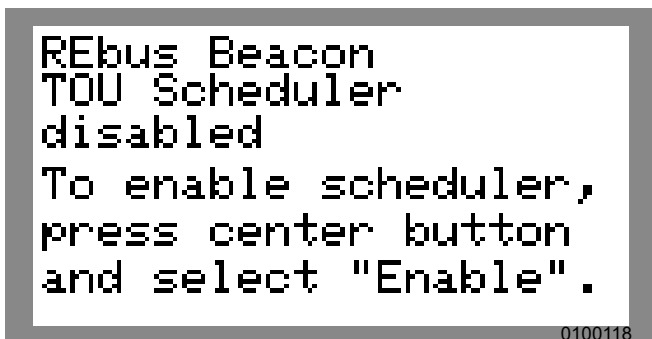

Figure 6-20. Disabling Beacon (3 of 3)

Enabling Generac Beacon

Once the TOU Schedule is set, the scheduler will automatically enable itself and begin running. However, if the scheduler has been disabled for any reason, the scheduler must be enabled to run. To enable the scheduler:

1. See [Figure 6-18](#). Navigate to the Generac Beacon device page and press the center button to enter the device menu.

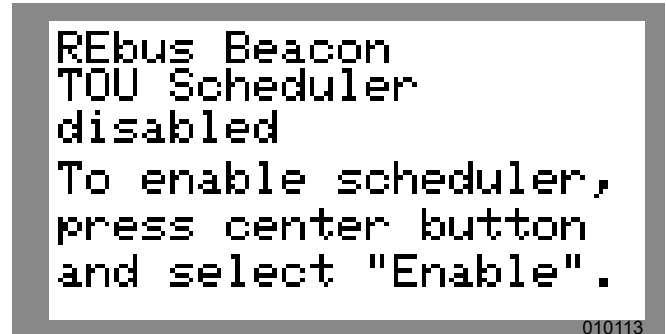

Figure 6-21. Enabling Beacon (1 of 2)

2. Highlight Disable and press the center button.
3. See [Figure 6-19](#). Arrow sideways to Confirm and press the center button.

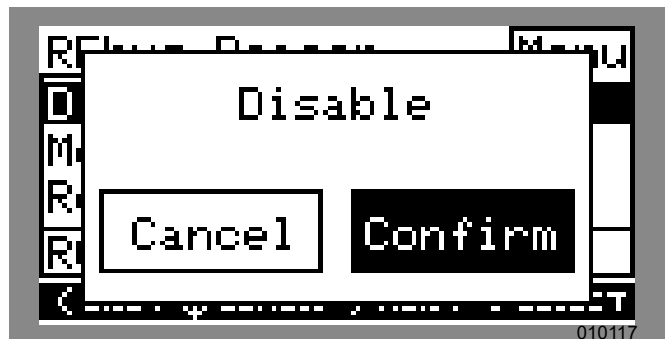

Figure 6-22. Enabling Beacon (2 of 2)

Temporarily Overriding the TOU Scheduler

The scheduler can be temporarily overridden at any time without disabling it. The manual override will apply until the next regularly scheduled operational mode change.

To temporarily override the scheduler:

1. Navigate to the system home page.
2. Press the center button.
3. Select the desired temporary operational mode.

NOTE: See the Generac PWRcell Inverter Owner's Manual for more information.

When the scheduler has been overridden:

- Temporary Override will display on the home page, alternating with the words Scheduler Active and the name of the current operational mode.
- See [Figure 6-23](#). Running, Overridden will display on the Generac Beacon device page.

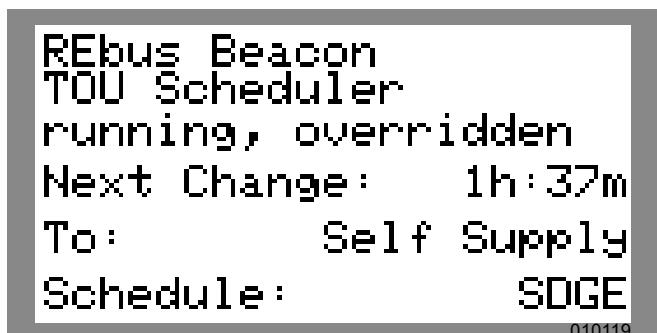

Figure 6-23. Overriding Scheduler

- The countdown timer on the Generac Beacon device page will indicate the remaining time until the next mode change.

After the next scheduled mode change, the scheduler will resume normal operation.

Disabling the TOU Scheduler in Anticipation of a Grid Outage

In the event of an impending storm and potential outage, top off the battery by disabling the scheduler and switching the operational mode to any of the backup modes.

To disable the TOU Scheduler:

1. Navigate to the Generac Beacon device page and disable the scheduler. See [Disabling Generac Beacon](#) for more information.
2. Navigate to the system home page and change the operational mode to a backup-only mode, such as Priority Backup or Clean Backup. See the Generac PWRcell Inverter Owner's Manual for more information on operational modes.
3. Once the emergency has passed, re-enable the scheduler. See [Enabling Generac Beacon](#) for more information.

NOTE: If Priority Backup mode is not listed with the other operational modes, the system installer may have removed the mode to comply with utility rules. Some utilities do not permit grid battery charging.

Commissioning Generac Beacon

NOTE: Follow all commissioning procedures for the Generac PWRcell Inverter and all connected REbus devices before commissioning the Generac Beacon. See [Commissioning the System](#) and [Enabling REbus Devices](#) for more information.

To commission the Generac Beacon:

1. Verify the control panel includes a Generac Beacon device page.
2. Verify the blue Internet LED on the front of the inverter is illuminated.
3. Enable all REbus devices.

NOTE: If necessary, turn ON the DC breakers for each connected REbus device.

4. Enable the inverter.
5. Enable each device. See [Enabling REbus Devices](#) for more information.
6. Turn the Battery Disconnect switch ON for each Generac PWRcell battery.
7. Return to the Beacon device page and enter the settings menu to access all settings, including the TOU schedule and time zone.

Generac Beacon will automatically enable and begin running the TOU schedule.

Ethernet Setup

1. Connect an Ethernet cable with a valid Internet connection into the inverter Ethernet port.
2. See [Figure 6-24](#). Use the control panel left arrow buttons to scroll to the Ethernet screen. If the screen reads Ethernet Disabled, follow steps 3 through 5 to enable Ethernet capability. Otherwise, skip to step 6.



Figure 6-24. Ethernet Configuration (1 of 4)

3. Press the center button to open the settings menu.

- See [Figure 6-25](#). Use the up and down arrows to highlight Enable Ethernet then press the center button.

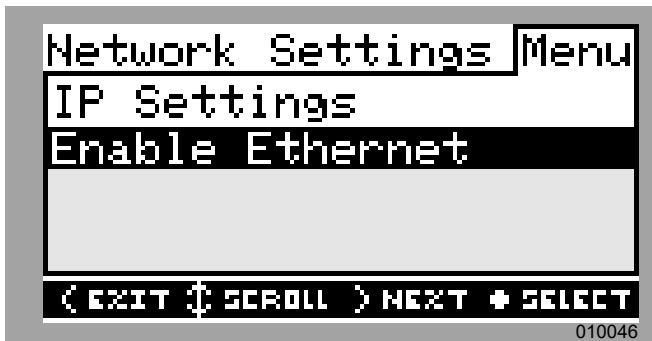

Figure 6-25. Ethernet Configuration (2 of 4)

NOTE: Select IP Settings for advanced settings.

- See [Figure 6-26](#). Press the right arrow to highlight Confirm then press the center button.

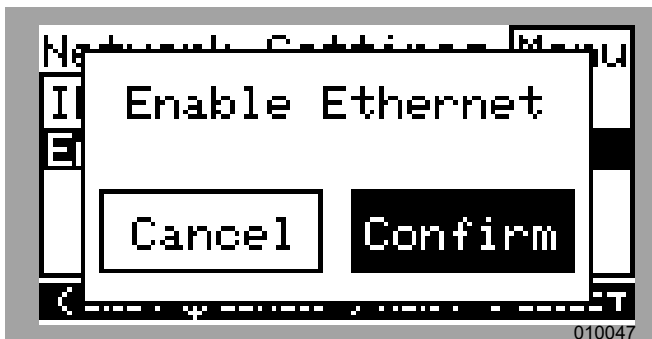

Figure 6-26. Ethernet Configuration (3 of 4)

- Verify the control panel Internet LED is lit indicating a valid Internet connection.

NOTE: If the Internet LED is not lit, see [Ethernet Troubleshooting](#).

- The Generac PWRcell system is now Ethernet-enabled and can send and receive data.
- Log onto <https://register.generac.com/> to sign up and register the REbus devices.

NOTE: See [Figure 6-27](#). The Ethernet screen on Generac PWRcell's Inverter LCD displays IP address, MAC address and connection status.

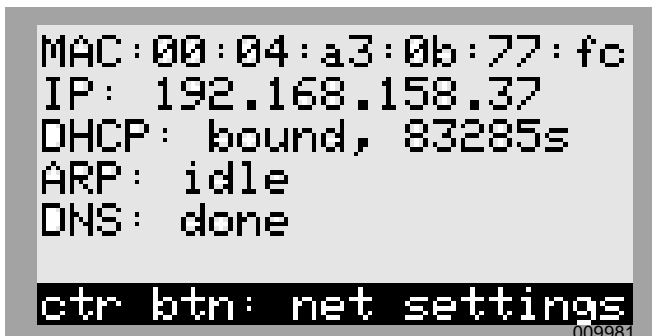

Figure 6-27. Ethernet Configuration (4 of 4)

Manually Configuring IP Settings

NOTE: On networks not configured for DHCP, use the MAC address to locate the device on the network.

To manually configure settings:

- See [Figure 6-28](#). Press the center button from the Ethernet settings screen and select IP Settings.



Figure 6-28. Ethernet Configuration (1 of 2)

- See [Figure 6-29](#). From the IP Settings menu select Manual.

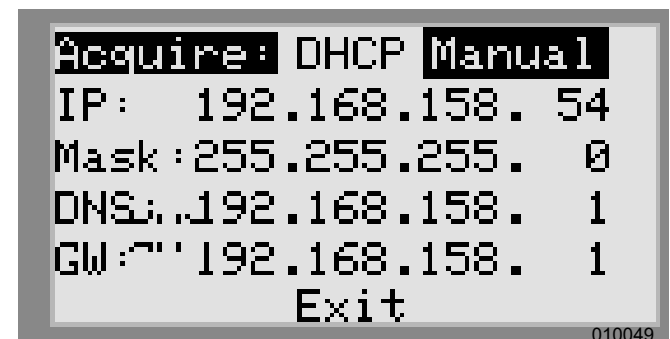

Figure 6-29. Ethernet Configuration (2 of 2)

- Adjust any of the following:

- IP
- Subnet Mask
- DNS
- Gateway

NOTE: Contact your network system administrator to connect the Generac PWRcell Inverter to a restricted network.

Ethernet Troubleshooting

NOTE: Use a laptop or other device to verify your Internet connection is working properly before troubleshooting.

For a successful connection the following must be valid:

- The Internet LED on the control panel must be lit.

NOTE: A lit Internet LED is a necessary, but not sufficient indication of a successful connection to the PWRview server. The blue LED may be lit even if the inverter is not connected to the server.

- A valid IP address must be displayed on the Ethernet settings page
- The PWRview State on the Ethernet settings page must read Listen.

NOTE: If the PWRview State reads Get Connected then a successful connection has not been made to the PWRview server

If the inverter does not automatically connect to the network and begin communicating with the PWRview server, perform the following steps:

1. Verify an Ethernet connection has been enabled by pressing the center button on the Ethernet page and selecting Enable Ethernet.
2. Verify the network is configured for DHCP and that DHCP is enabled.
3. If the network is not configured for DHCP, obtain the MAC address and contact the system administrator for IP address assignment.
4. Input IP address under Manual settings. See [Serial Number and Registration](#).
5. Restart router and modem.
6. Contact system administrator for further troubleshooting steps.

NOTE: It is the installer's responsibility to make sure the Internet connection is reliable and secure. Generac recommends always using a hardwired connection. Generac does not recommend or support using any wireless or power line carrier network devices. Use these devices at your own discretion.

Serial Number and Registration

NOTE: If it is not possible to connect the system to the Internet, please call Generac Customer Service at 1-888-GENERAC (1-888-436-3722) to complete registration.

NOTE: Registering an inverter automatically registers all REbus system components connected to that inverter.

Every REbus-enabled device can be monitored from the PWRview™ online monitoring system and mobile app.

To register a system for PWRview monitoring:

1. See [Figure 6-30](#). Locate the serial number and registration code on the registration decal on the front of the inverter. This information will be required for registration.
2. Navigate to <https://register.generac.com/> or if using a mobile device scan the registration label QR code.
3. Follow the on-screen prompts to complete the profile.

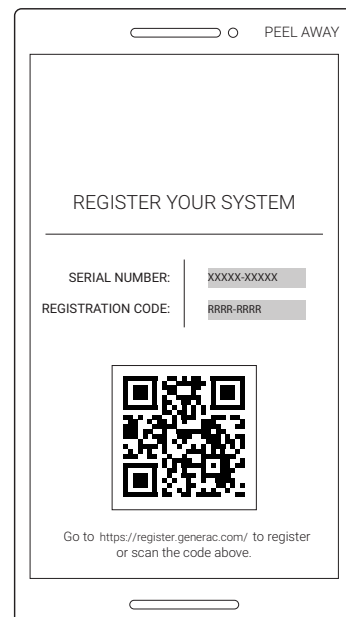

009984

Figure 6-30. Registration Decal

Section 7: Maintenance

Service



⚠ DANGER

Electrocution. Verify all system voltages are safe before wiring. Disconnect all AC and DC sources of power before touching terminals. Failure to ensure no dangerous voltages are present on conductors and terminals before wiring will result in death or serious injury. (000642)



⚠ DANGER

Electrocution. Initiate a system-wide safety shutdown and turn PWRcell Disconnect Switch OFF on all connected batteries before performing service. Failure to do so will result in death, serious injury, equipment and property damage. (000600)

For any servicing needs, contact the nearest Independent Authorized Service Dealer (IASD) or Generac Customer Service at 1-888-436-3722 (1-888-GENERAC), or visit www.generac.com.

Accessing Wiring Compartment

To access the wiring compartment:

1. Initiate a Safety Shutdown and allow DC voltage to drop to a safe level.
2. Power down inverter
3. Disconnect all sources of AC and DC Power.
4. See [Figure](#) . Open inverter front cover by lifting the bottom to horizontal (A) and pushing inward (B).
5. Locate wiring compartment cover (C).
6. Remove five M4X10 screws (D) and wiring compartment cover.

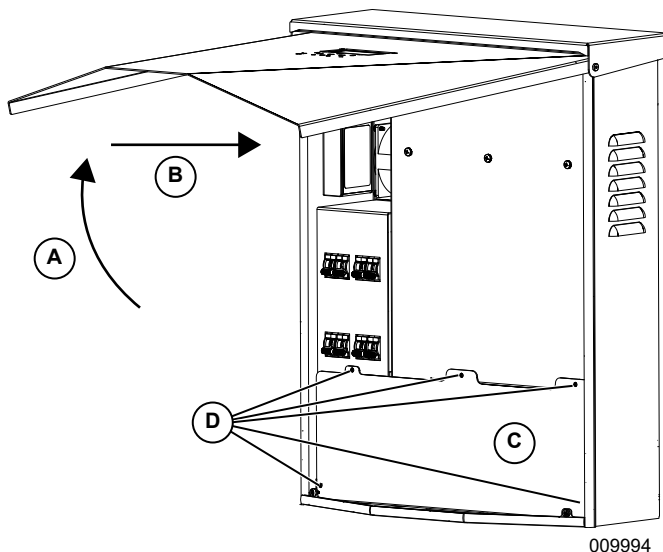

009994

Figure 7-1. Wiring Compartment

Replacing Fuses

⚠ WARNING

Equipment damage. Never replace a fuse with a different size or style. Doing so will void the inverter warranty and could result in equipment or property damage. (000653)

⚠ WARNING

Equipment damage. Never remove DC fuses under load. Removing DC fuses under load could result in equipment or property damage.

(000652)

Two main fuses are installed between the power core and the DC breakers. See [Generac PWRcell Inverter Wiring Compartment](#) for location.

If a main fuse has blown, determine the root cause of the issue before replacing it. For assistance, contact the nearest Independent Authorized Service Dealer (IASD) or Generac Customer Service at 1-888-436-3722 (1-888-GENERAC), or visit www.generac.com.

To replace a fuse:

1. Initiate a Safety Shutdown and allow DC voltage to drop to a safe level.
2. Power down the inverter.
3. Disconnect all sources of AC and DC power.
4. Removing wiring compartment cover. See [Accessing Wiring Compartment](#).
5. See [Figure 7-2](#). Locate DC fuse holders (B)
6. Press fuse holder up and turn counterclockwise to release.
7. Remove fuse from fuse holder.
8. Insert replacement fuse into fuse holder.
9. Reinstall fuse holder. Turn clockwise until tight.

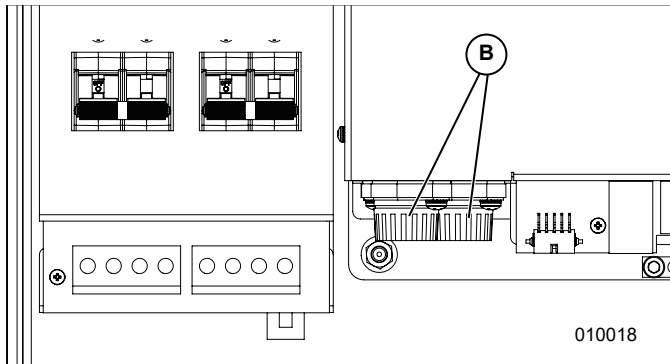

Figure 7-2. Removing Wiring Compartment Cover

Recovery From an Error State

Error events will force Generac PWRcell Inverter into an error state where no DC power is exported, though voltage may still be present on REbus from connected devices.

To recover a device from an error state, use the front control panel to disable and then enable to device.

If the system is unable to be accessed, but is connected to the Internet, contact Generac Technical support for assistance in resetting an error state.

Section 8: Troubleshooting

General Troubleshooting

Some of the more common problems are listed in the table below. This information is intended to be a check or verification that simple causes can be located and fixed. It does not cover all types of problems. Procedures that require in-depth knowledge or skills should be referred to an Independent Authorized Service Dealer.

Table 8-1. General Troubleshooting Guide

Problem	Possible Cause	Solution
System will not exit Safety Shutdown	External shutdown button not depressed	Depress external shutdown button
	No jumper between STOP terminals	Verify jumper is in place between STOP terminals.
CTs will not calibrate	Loose connection	Check CT wiring.
		Power down inverter, allow screen to go blank, then power inverter ON.
No REbus Beacon device page	Beacon USB cable not connected	Verify Beacon USB cable is connected at both ends. Verify the USB cable is correctly connected to the Beacon and also to the Beacon accessory port in the inverter wiring compartment.
	Beacon wrap-around cable not connected	Verify the short wrap-around cable is plugged into Beacon, from one port to the other.
Inverter isn't connected to server	Inverter not connected to the Internet	Verify the inverter is connected to the Internet via a router.

If problems persist, contact the nearest Independent Authorized Service Dealer (IASD) or Generac Customer Service at 1-888-436-3722 (1-888-GENERAC).

This page intentionally left blank.

This page intentionally left blank.

This page intentionally left blank.

Part No. DMAN00007 Rev. A 10/25/19
©2019 Generac Power Systems, Inc.
All rights reserved.
Specifications are subject to change without notice.
No reproduction allowed in any form without prior written
consent from Generac Power Systems, Inc.

GENERAC®

Generac Power Systems, Inc.
S45 W29290 Hwy. 59
Waukesha, WI 53189
1-888-GENERAC (1-888-436-3722)
www.generac.com