

CS110FV

In-Field Verifier for
CS110 Electric Field Meter



Limited Warranty

“Products manufactured by CSI are warranted by CSI to be free from defects in materials and workmanship under normal use and service for twelve months from the date of shipment unless otherwise specified in the corresponding product manual. (Product manuals are available for review online at www.campbellsci.com.) Products not manufactured by CSI, but that are resold by CSI, are warranted only to the limits extended by the original manufacturer. Batteries, fine-wire thermocouples, desiccant, and other consumables have no warranty. CSI’s obligation under this warranty is limited to repairing or replacing (at CSI’s option) defective Products, which shall be the sole and exclusive remedy under this warranty. The Customer assumes all costs of removing, reinstalling, and shipping defective Products to CSI. CSI will return such Products by surface carrier prepaid within the continental United States of America. To all other locations, CSI will return such Products best way CIP (port of entry) per Incoterms ® 2010. This warranty shall not apply to any Products which have been subjected to modification, misuse, neglect, improper service, accidents of nature, or shipping damage. This warranty is in lieu of all other warranties, expressed or implied. The warranty for installation services performed by CSI such as programming to customer specifications, electrical connections to Products manufactured by CSI, and Product specific training, is part of CSI’s product warranty. **CSI EXPRESSLY DISCLAIMS AND EXCLUDES ANY IMPLIED WARRANTIES OF MERCHANTABILITY OR FITNESS FOR A PARTICULAR PURPOSE. CSI hereby disclaims, to the fullest extent allowed by applicable law, any and all warranties and conditions with respect to the Products, whether express, implied or statutory, other than those expressly provided herein.**”

Assistance

Products may not be returned without prior authorization. The following contact information is for US and international customers residing in countries served by Campbell Scientific, Inc. directly. Affiliate companies handle repairs for customers within their territories. Please visit www.campbellsci.com to determine which Campbell Scientific company serves your country.

To obtain a Returned Materials Authorization (RMA) number, contact CAMPBELL SCIENTIFIC, INC., phone (435) 227-9000. Please write the issued RMA number clearly on the outside of the shipping container. Campbell Scientific's shipping address is:

CAMPBELL SCIENTIFIC, INC.

RMA# _____
815 West 1800 North
Logan, Utah 84321-1784

For all returns, the customer must fill out a "Statement of Product Cleanliness and Decontamination" form and comply with the requirements specified in it. The form is available from our website at www.campbellsci.com/repair. A completed form must be either emailed to repair@campbellsci.com or faxed to (435) 227-9106. Campbell Scientific is unable to process any returns until we receive this form. If the form is not received within three days of product receipt or is incomplete, the product will be returned to the customer at the customer's expense. Campbell Scientific reserves the right to refuse service on products that were exposed to contaminants that may cause health or safety concerns for our employees.

Safety

DANGER — MANY HAZARDS ARE ASSOCIATED WITH INSTALLING, USING, MAINTAINING, AND WORKING ON OR AROUND TRIPODS, TOWERS, AND ANY ATTACHMENTS TO TRIPODS AND TOWERS SUCH AS SENSORS, CROSSARMS, ENCLOSURES, ANTENNAS, ETC. FAILURE TO PROPERLY AND COMPLETELY ASSEMBLE, INSTALL, OPERATE, USE, AND MAINTAIN TRIPODS, TOWERS, AND ATTACHMENTS, AND FAILURE TO HEED WARNINGS, INCREASES THE RISK OF DEATH, ACCIDENT, SERIOUS INJURY, PROPERTY DAMAGE, AND PRODUCT FAILURE. TAKE ALL REASONABLE PRECAUTIONS TO AVOID THESE HAZARDS. CHECK WITH YOUR ORGANIZATION'S SAFETY COORDINATOR (OR POLICY) FOR PROCEDURES AND REQUIRED PROTECTIVE EQUIPMENT PRIOR TO PERFORMING ANY WORK.

Use tripods, towers, and attachments to tripods and towers only for purposes for which they are designed. Do not exceed design limits. Be familiar and comply with all instructions provided in product manuals. Manuals are available at www.campbellsci.com or by telephoning (435) 227-9000 (USA). You are responsible for conformance with governing codes and regulations, including safety regulations, and the integrity and location of structures or land to which towers, tripods, and any attachments are attached. Installation sites should be evaluated and approved by a qualified engineer. If questions or concerns arise regarding installation, use, or maintenance of tripods, towers, attachments, or electrical connections, consult with a licensed and qualified engineer or electrician.

General

- Prior to performing site or installation work, obtain required approvals and permits. Comply with all governing structure-height regulations, such as those of the FAA in the USA.
- Use only qualified personnel for installation, use, and maintenance of tripods and towers, and any attachments to tripods and towers. The use of licensed and qualified contractors is highly recommended.
- Read all applicable instructions carefully and understand procedures thoroughly before beginning work.
- Wear a **hardhat** and **eye protection**, and take **other appropriate safety precautions** while working on or around tripods and towers.
- **Do not climb** tripods or towers at any time, and prohibit climbing by other persons. Take reasonable precautions to secure tripod and tower sites from trespassers.
- Use only manufacturer recommended parts, materials, and tools.

Utility and Electrical

- **You can be killed** or sustain serious bodily injury if the tripod, tower, or attachments you are installing, constructing, using, or maintaining, or a tool, stake, or anchor, come in **contact with overhead or underground utility lines**.
- Maintain a distance of at least one-and-one-half times structure height, 20 feet, or the distance required by applicable law, **whichever is greater**, between overhead utility lines and the structure (tripod, tower, attachments, or tools).
- Prior to performing site or installation work, inform all utility companies and have all underground utilities marked.
- Comply with all electrical codes. Electrical equipment and related grounding devices should be installed by a licensed and qualified electrician.

Elevated Work and Weather

- Exercise extreme caution when performing elevated work.
- Use appropriate equipment and safety practices.
- During installation and maintenance, keep tower and tripod sites clear of un-trained or non-essential personnel. Take precautions to prevent elevated tools and objects from dropping.
- Do not perform any work in inclement weather, including wind, rain, snow, lightning, etc.

Maintenance

- Periodically (at least yearly) check for wear and damage, including corrosion, stress cracks, frayed cables, loose cable clamps, cable tightness, etc. and take necessary corrective actions.
- Periodically (at least yearly) check electrical ground connections.

WHILE EVERY ATTEMPT IS MADE TO EMBODY THE HIGHEST DEGREE OF SAFETY IN ALL CAMPBELL SCIENTIFIC PRODUCTS, THE CUSTOMER ASSUMES ALL RISK FROM ANY INJURY RESULTING FROM IMPROPER INSTALLATION, USE, OR MAINTENANCE OF TRIPODS, TOWERS, OR ATTACHMENTS TO TRIPODS AND TOWERS SUCH AS SENSORS, CROSSARMS, ENCLOSURES, ANTENNAS, ETC.

Table of Contents

PDF viewers: These page numbers refer to the printed version of this document. Use the PDF reader bookmarks tab for links to specific sections.

1. Introduction.....	1
2. Precautions	1
3. Initial Inspection	1
4. QuickStart	2
4.1 Installing the Verifier	2
4.2 Setting Up the Verifier	3
4.3 Running the Verification Process.....	4
4.4 Viewing Verification Results	5
4.5 Using the Keypad.....	5
5. Overview	6
6. Specifications	6
7. Troubleshooting	7
8. Maintenance.....	8
8.1 Cleaning the Verifier Test Cover	8

Appendices

A. Calibration of the CS110FV In-Field Verifier	A-1
B. Detailed Operation.....	B-1
B.1 Verification Program.....	B-2
B.2 SDM-CD16AC Relay Switch Functions.....	B-7
B.3 Current Drain at Different Stages in the Verification Process	B-8
C. Verifier Calibration Uncertainty	C-1

Figures

4-1. Test cover installed on the CS110. Arrows indicate the installation alignment points.....	2
4-2. Inside the Verifier	3
B-1. CS110FV In-Field Verifier Schematic.....	B-1
C-1. Test cover installed on the CS110. Arrows indicate the installation alignment points.....	C-2

Table

C-1. Uncertainty in CS110FV In-Field Verifier System.....C-4

CS110FV In-Field Verifier

1. Introduction

The Campbell Scientific CS110FV In-Field Verifier (Verifier) is a portable device used to verify the factory calibration of a CS110 MPARALLEL PLATE (MPP) multiplier while the CS110 is installed in the field or a laboratory. This can reduce or eliminate the need to transport the CS110 to a laboratory or send it to Campbell Scientific for recalibration. The Verifier accuracy is better than 1% so it is able to calibrate CS110s with a tolerance better than 3%.

The Verifier is housed in a rugged Pelican case designed for work in the field. It includes a test cover that fits over the CS110 stator, a 12 Vdc alkaline battery pack, and a GPS sensor to record the location of the CS110 being verified.

2. Precautions

- **CAUTION:** While the CS110FV In-Field Verifier is designed for field work, it is a calibration/verification tool and as such should be treated with care. Campbell Scientific suggests placing the Verifier on the back seat instead of in the bed of a pickup when driving on rugged 4-wheel drive roads. When shipping or transporting on an airplane, remove the alkaline D cells, and pack it in a cushioned carton or case (TSA agents get nervous when you try to carry it onboard an airplane).
- **CAUTION:** Do not touch the inside surfaces of the Verifier test cover. Oily fingerprints can affect the verification. Test cover cleaning instructions are in Section 8, *Maintenance* (p. 8).

3. Initial Inspection

The Verifier ships with

- Quick Start Guide
- CS110FV In-Field Verifier Calibration Report
- CR1000 Calibration Certificate
- CS110 Calibration Certificate (transfer standard)
- 8 alkaline D batteries (outside of the Pelican case but in the same carton)

Upon receipt of the CS110FV In-Field Verifier, inspect the packaging and contents for damage. File damage claims with the shipping company. Contact Campbell Scientific to facilitate repair or replacement.

Immediately check package contents against shipping documentation. Thoroughly check all packaging material for product that may be trapped inside it. Contact Campbell Scientific immediately about discrepancies. Model numbers are found on each product. On cables, the model number is often found at the connection end of the cable.

4. QuickStart

4.1 Installing the Verifier

1. Open the Verifier case. Unplug the power connector, remove the alkaline battery pack, and install the 8 alkaline D cell batteries. Then, reinstall the battery pack and power connector.
2. Remove the test cover and its cable. Install the test cover over the CS110 stator, making sure the holes align with the two screws on the stator. Hold the other end of the test cover so the stop on the cover maintains contact with the rim of the stator. Tighten the thumb screws to hold it in place (FIGURE 4-1).

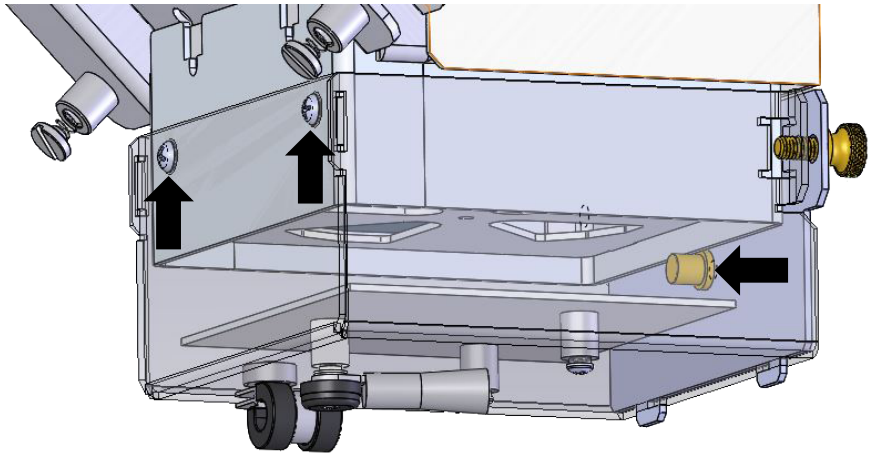

FIGURE 4-1. Test cover installed on the CS110. Arrows indicate the installation alignment points.

3. To ground the unit, loosen one of the six screws that secure the CS110 lid. Slide the ground lug under the screw head and tighten. Connect the plastic connector of the Verifier cable to the CS110 **RS-232** port. Connect the metal connector of the cable to the connector in the top right corner of the Verifier.



FIGURE 4-2. Inside the Verifier

4.2 Setting Up the Verifier

To set up the Verifier, you will need the following information:

- Serial number (from 1001 to 5001) – This is found on the sticker on the CS110 and the CS110 calibration certificate.
 - Original **MPARALLEL PLATE** (from 79.99 to 100) – This is found on the sticker on the CS110 and the CS110 calibration certificate.
 - **Csite** (from 0.01 to 10.01, default = 0.1) – This is found in the CS110 program *Constant Table*.
 - **PakBus Address** (from 1 to 3998, default = 1) – This is found in the CS110 settings.
 - RS-232 baud rate (default = 115200, SG000 option = 2400)
 - Electric field variable name (default = **EFM_Efield_v_m** or **EFM_Efield**) – This is the name of the *Public table* variable that holds the one-second electric field value in the CS110.
 - **Security Code**. If security has been set in the CS110, it will need to be entered. If not, the default of 0 will work.
1. Turn on the CS110 and make sure it is shuttering every second. If it is not shuttering every second, load the default shipping program, named “CS110 Shipping Program 20080515.CR1”, or any other program with that effect.
 2. Use the switch to turn on the Verifier.

NOTE

Refer to Section 4.5, *Using the Keypad (p. 5)*, for help with the keypad display.

3. On the Verifier display, select **Enter Setup Values**. Press **Enter**, and enter the following setup values and settings:
 - Serial number (**CS110 SN**)
 - Original MPARALLEL PLATE (**CS110 MMP**)
 - Csite (**CS110 Csite**)
 - PakBus Address (**PakBus Addr**)
 - RS-232 **Baud Rate**
 - Electric field variable name (**Efield Var**)
 - Enable or disable the Verifier GPS sensor (**GPS T=-1, F=0**). The default is *False*.
 - If the GPS is enabled, type the UTC offset in hours (**UTC OffsetHr**), from -12 to $+12$.

Then, set **ApplyChanges** to *TRUE* to apply changes.

After installing the Verifier and setting these values, the green **Test Ready** LED should turn on, and you can proceed to Section 4.3, *Running the Verification Process* (p. 4). If the **Test Ready** LED does not turn on, use the following instructions.

If the Test Ready LED does not turn on, go to View Efield, GPS, Battery in the main menu and check the following:

- If the Verifier is getting the one-second electric field data from the CS110, a small electric field reading will be displayed when the test cover is on. A **-99999** could indicate an incorrect PakBus address, baud rate, or electric field variable name, or it could indicate a cable or connector issue.
- If the GPS is enabled and a satellite is found, the latitude, longitude and number of satellites will be displayed. If the GPS hasn't locked on to a satellite, the GPS will display **-99999**. It can take 3 to 4 minutes for the GPS to lock on to a satellite.
- If the Verifier battery is low (< 9.6 Vdc), it will display **-99999** or the unit will not power up (no/bad display screens). Replace the batteries.

Press **ESC** to exit to the main menu.

4.3 Running the Verification Process

1. Select **Start Verify or Abort**, and then set **Start_Verify** to **TRUE** to start the verification process. The **Test In Progress** LED will turn on and remain on until the process is complete. Press **ESC** to exit to the main menu.
2. Select **View Verify Progress** to watch the verification progress. You will see each step as it is completed, including the following:
 - Voltage applied by the charge plate
 - Voltage measured by the CS110
 - Security code of the CS110 if any (**Security**). The default is 0.

3. When the verification process finishes, the **Test In Progress** LED will turn off and the **Test Ready** LED will turn on.
4. Press **ESC** to exit to the main menu.

4.4 Viewing Verification Results

After the verification process is complete, you can select **View Verify Results**. The following values are given:

- CS110 serial number (**CS110 SN**)
- CS110 original MPARALLEL PLATE (**CS110origMPP**)
- Verified MPARALLEL PLATE (**Verified MPP**)
- MPARALLEL PLATE percent change (**MPP % Change**) (should be <4%)
- **Verified R2** (should be close to 1.0)
- Verify Offset (**Verify Offset**)
- **Verify Zero** – This is the CS110 electric field measurement when the charge plate voltage is zero. A clean CS110 should have a **Verify Zero** value of < 6 V/m when the **CS110 Csite** factor is set to 0.1 (default).

Press **Esc** to exit to the main menu. The verification results are stored in the Verifier's final memory data table named *Fit*. You can retrieve these results from the Verifier using Campbell Scientific *Device Configuration Utility* or *LoggerNet* software, available at www.campbellsci.com.

Turn the Verifier off after use.

4.5 Using the Keypad

The 16 keys default to **▲, ▼, ◀, ▶, Home, PgUp, End, PgDn, Del, and Ins**.

To enter numbers, first press **Num Lock**. **Num Lock** stays set until pressed again.

Above all keys, except **Num Lock** and **Shift**, are characters printed in blue. To enter one of these characters, press **Shift** one to three times to select the position of the character as shown above the key, then press the key. For example, to enter *Y*, press **Shift Shift Shift PgDn**.

To insert a space (**Spc**), press **Shift** once, then press **BkSpc**.

To change to lower or upper case (**Cap**), press **Shift** twice rapidly, then press **BkSpc**.

To insert a character not printed on the keyboard, enter **Ins**, scroll down to *Character*, press **Enter**, then press **▲, ▼, ◀, ▶** to scroll to the desired character in the list that is presented, then press **Enter**.

5. Overview

The CS110FV In-Field Verifier was designed and built to determine if a given CS110 calibration factor (**MPARALLEL PLATE**) is still within 4% of the original factory calibration.

The Verifier verifies a CS110 calibration factor (**MPARALLEL PLATE**) by determining its own **MPARALLEL PLATE** factor for the CS110. This is done by applying measured dc voltages to a metal charge plate mounted close to the CS110 sense electrode and regressing the CS110 measured electric field against the Verifier applied electric field. Each Verifier has a unique factory calibration factor of its own (**EFFECTIVE DISTANCE**) due to small mechanical variations in a Verifier test cover.

Inside the Verifier is a CR1000 that controls an SDM-CD16AC multiplexer, which controls two indicator LEDs and sends a sequence of dc voltages (–48, –40, –30, –16, 0, 16, 30, 40, 48) to the charge plate inside the test cover. The green **Test Ready** LED indicates when the Verifier has all the data it needs to start the verification. The red LED indicates **Test In Progress**. The sequenced voltages are created by a 12 Vdc to 48 Vdc converter and a set of voltage divider resistors.

The applied voltages are measured by the Verifier using a 10-to-1 voltage divider. When the voltages are being applied, the Verifier retrieves the CS110 electric field measurements via its RS-232 connection. The Verifier then does a linear regression on the CS110 measurements and the applied voltages, accounting for the effective distance from the test-cover charge plate to the CS110 sense electrode. The result of the regression is a new **MPARALLEL PLATE** factor. The Verifier **View Results** displays the original and new **MPARALLEL PLATE** factors and the percent change.

If the change is greater than 4% (or a user-chosen percentage), clean the CS110, then carefully reinstall the CS110 stator, and repeat the verification. If these steps do not reduce the percent change, either switch to the new **MPARALLEL PLATE** factor or return the CS110 to the factory for recalibration. While not as critical, a clean CS110 **Verified Zero** result should be less than 6 V/m (assuming the CS110 being calibrated has a *Csite factor* = 0.1).

6. Specifications

Verifier calibration accuracy:	0.78%
Electric field verification points:	±2300 V/m, ±2000 V/m, ±1500 V/m, ±750 V/m, ±0 V/m
MPP verification accuracy¹:	±3%
MPP verification repeatability:	±0.06%
Operating temperature:	–25 to 50 °C
Power supply voltage:	9.6 to 16 Vdc

External batteries:	12 Vdc nominal, provided by 8 alkaline D batteries. Power connection is reverse-polarity protected.
Current drain	
Idle with display timed out:	< 25 mA
Idle with display on:	225 mA
During verification with GPS sensor on:	425 mA
Internal battery:	1200 mAh lithium battery for clock and SRAM backup that typically provides three years of backup
RS-232 ports:	DCE 9-pin: (not electrically isolated) for computer connection or connection of modems not manufactured by Campbell Scientific.
Certification:	View the EU Declaration of Conformity at www.campbellsci.com/cs110fv
Weight:	8.2 kg (18 lb)
Shipping weight:	10.9 kg (24 lb)
Dimensions:	43 × 33 × 18 cm (17 × 13 × 7 in)
Shipping dimensions:	51 × 41 × 31 cm (20 × 16 × 12 in)

¹ The Verifier calibration uncertainty is 0.78%, corresponding to a confidence level of 95%. Therefore, when the Verifier temperature is between 0 and 40 °C, the Verifier is able to calibrate CS110 electric field meters with a tolerance better than 3%, assuming the standard test uncertainty ratio (TUR) of 4:1. See Appendix C, *Verifier Calibration Uncertainty (p. C-1)*, for details.

7. Troubleshooting

For additional assistance, contact the Campbell Scientific group company for your area. Campbell Scientific support personnel have access to the following documents to aid in troubleshooting:

Schematics:	SUB CS110FV ELECTRONICS IN PELICAN CASE (SCH32638B) PCS CS110FV VOLTAGE & POLARITY SELECT (SCH32663A)
CS110FV Default Program:	CS110FV_Shipping Program 20180426 SNxxxx.CR1
CS110 Default Program:	CS110_Shipping Program 20080515.CR1

8. Maintenance

NOTE

All factory repairs and recalibrations require a returned material authorization (RMA) and completion of the “Declaration of Hazardous Material and Decontamination” form. Refer to the [Assistance](#) page at the beginning of this manual for more information.

Every three years, recalibrate the CR1000 in the Verifier. The Verifier can be returned to Campbell Scientific for this service. Alternatively, the CR1000 calibration can be verified by measuring the voltages applied to the test cover charge plate with a calibrated precision volt meter and comparing them with the voltages measured by the CR1000.

Monitor the CR1000 internal lithium battery and replace it when its voltage drops to 2.7 Vdc. See the CR1000 manual for details.

Replace the alkaline D cells before the voltage drops below 9.6 Vdc.

Keep the Verifier dry enough to prevent moisture condensation. If necessary, place some desiccant inside the Verifier when it is to be placed in storage.

8.1 Cleaning the Verifier Test Cover

Contamination of the polished charge plate and internal surfaces of the test cover can cause surface charges that induce electric field offset errors in the verification.

Clean the Verifier test cover if there is contamination such as finger prints. Ensure that the CS110 electrode head is clean (see CS110 Electrode Head cleaning procedure in the [CS110 manual](#)). If the CS110 electrode head is clean but the **Verify Zero** result divided by the **Csite** exceeds ± 60 V/m, use the following procedure to clean the Verifier test cover:

1. Use a clean toothbrush to carefully wash the charge plate and interior test cover surfaces with soap (Alkanox® is recommended) and hot water if available.
2. Rinse well with deionized water.
3. Blow dry with clean, oil-free air.
4. Run the verification procedure on a clean CS110 and confirm the **Verify Zero** reading is less than ± 60 V/m ($= \text{Verify Zero} / \text{Csite}$).

NOTES

Rubbing and wiping may induce surface charging that will eventually dissipate. Therefore, let the test cover sit overnight before using it for a verification.

If necessary, the test cover can be disassembled, cleaned, and reassembled. Use clean cotton gloves to reassemble.

Appendix A. Calibration of the CS110FV In-Field Verifier

Calibration of the first CS110FV In-Field Verifier

Three CS110s were cleaned and calibrated using Campbell Scientific Parallel Plate Calibrator (PPC) with the aid of the 45° installation guide. These three CS110s were used to calibrate the Verifier using a reference distance of 20 mm and multiple excitation voltages obtained using resistor dividers with 48 Vdc power supply. The reference distance is the distance from the CFV charge plate to the CS110 sense electrode, as determined by SolidWorks models of both devices. The excitation voltage is the voltage applied to the Verifier's charge plate. The 48-Volt power supply gave approximate applied voltages of 48, 40, 30, 16, 0, -16, -30, -40, -48 Vdc.

When a CS110 is factory-calibrated using Campbell Scientific PPC, the rim of the CS110 is mounted flush with the inside surface of the top of the PPC. The distance from the top surface to the charge plate is the PPC reference distance. Using three freshly calibrated CS110s, we calibrated the Verifier. To make the Verifier MPPs match the PPC MPPs, the Verifier reference distance of 20 mm was changed to a calibrated **EFFECTIVE DISTANCE** of 10.5 mm. The reason the effective distance is 10.5 mm when the reference distance was 20 mm is due to edge effects associated with the much smaller CFV verification fixture. Apparently, these edge effects increase the applied electric fields for a given excitation voltage. The enhancing edge effects require the use of the smaller calibrated distance known as the **EFFECTIVE DISTANCE**.

While it doesn't affect the ability of the Verifier to verify CS110 calibrations, to meet the design goal of applied electric fields of ± 2400 V/m, ± 2000 V/m, 1500 V/m and 750 V/m, all subsequent Verifiers were built with a reference distance of 30 mm, which gives an **EFFECTIVE DISTANCE** near 20 mm.

Each Verifier has a unique **EFFECTIVE DISTANCE** that is entered in "Verifier_Shipping Program 20180403.cr1" at the factory using the **Public** table variable named **PlateDist**. An example label placed on the test cover might have "SN1002 EFFECTIVE DISTANCE 0.02088". Each test cover is slightly different mechanically due to small manufacturing tolerances. Therefore, the **EFFECTIVE DISTANCE** is different for each test cover.

The **EFFECTIVE DISTANCE** factor for each Verifier is determined by verifying one or more CS110s that have been recently calibrated on a Campbell Scientific Parallel Plate Calibrator (see [CS110 manual](#) for details). The Verifier being calibrated verifies with its **EFFECTIVE DISTANCE (PlateDist)** set to 1.00. The following example shows the calculation of the calibrated **EFFECTIVE DISTANCE**:

$$\text{EFFECTIVE DISTANCE} = \text{verification result} / \text{calibrating CS110 MPARALLEL PLATE}$$

$$\text{EFFECTIVE DISTANCE} = 1.8218 \text{ V/mV} / 87.25 \text{ V/(m}\cdot\text{mV)}$$

$$\text{EFFECTIVE DISTANCE} = 0.02088 \text{ m}$$

Appendix B. Detailed Operation

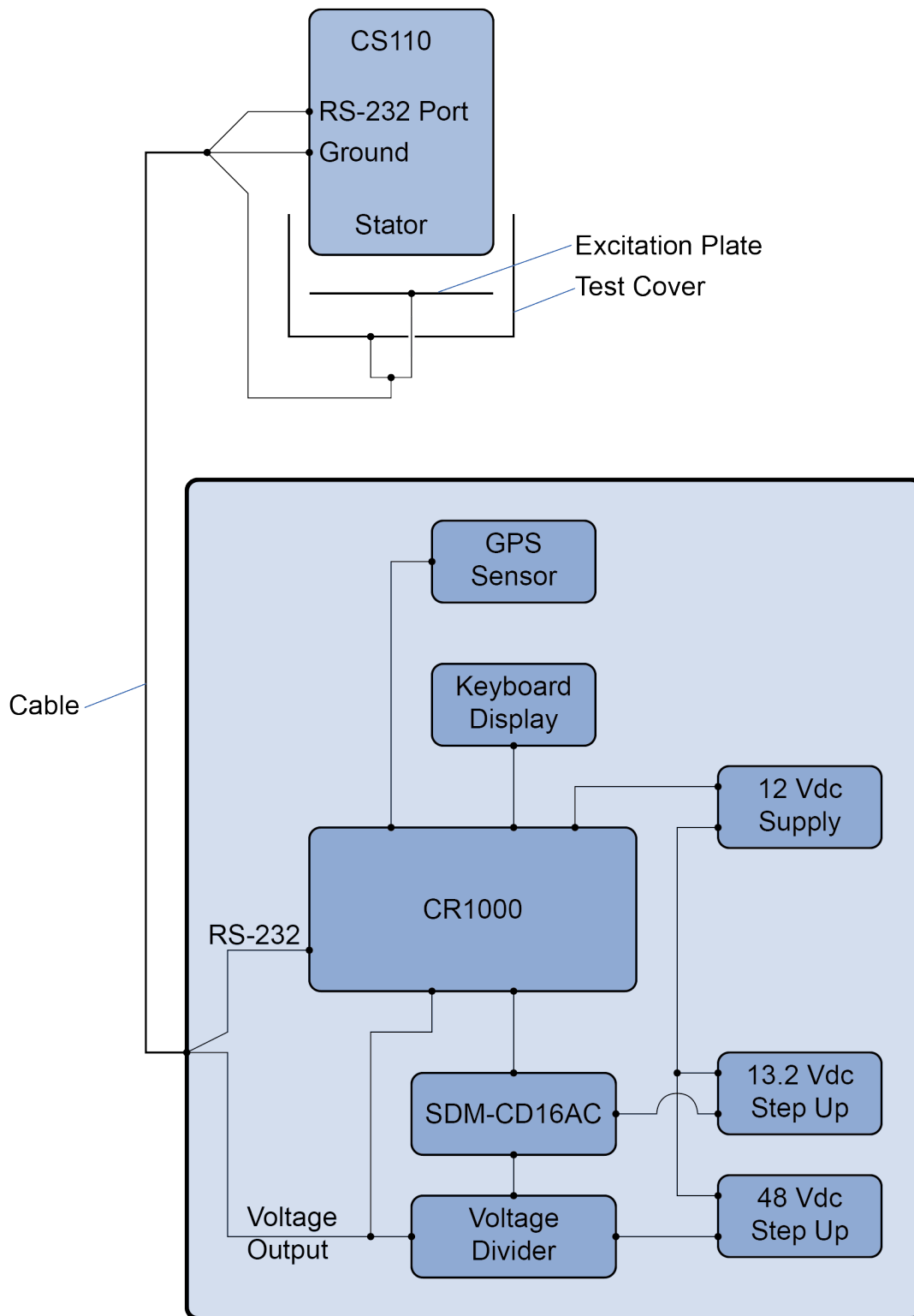

FIGURE B-1. CS110FV In-Field Verifier Schematic

B.1 Verification Program

NOTE The verify process takes approximately 1 minute 40 seconds.

Upon power-up:

- All switches and LEDs are set to off.
- If **GPS sensor setup** is set to **True** (–1) then 12 Vdc power is applied to the GPS sensor. Sensor attempts to acquire latitude/longitude from GPS satellites.
- Battery voltage and internal temperature are measured.
- Verifier starts its attempts to get the current 1-second electric fields from the CS110 being verified. The Pakbus address and baud rate must be correct for this to work.
- Verifier then range-checks the following measured values and user-entered setup values:
 - $1001 < \text{CS110 serial number} < 5001$
 - $79.99 < \text{Original MPP} < 100.1$
 - $0.01 < \text{Csite} < 10.01$
 - $1 < \text{PakBus Address} < 3999$
 - $2400 \leq \text{baud rate} < 115300$
 - Verifier is successfully getting data from the CS110 (**Public** table variable **GetVarResult** = 0)
 - **Battery voltage** > 9.6 Vdc
 - If **GPS** set to **True**, $-12 < \text{UTC offset} < 12$
 - If **GPS** set to **True**, **# of satellites** ≥ 1
 - If all above range checks pass, then the **Test Ready** LED is turned on, and the charge plate is grounded to the test cover. If any of the above fail, the **Test Ready** LED remains off and all switches remain off until all the range checks pass. Troubleshoot or fix the above until the **Test Ready** LED turns on.
- Once the green **Test Ready** LED is on, the Verifier then waits for the *Start Verify* flag to be set to **TRUE**. It will not verify until the **Test Ready** LED is on.
- When the *Start Verify* flag is set to **TRUE**, the switch sequence shown below occurs. During the time that each of the voltages of –48, –40, –30, –16, 0, 16, 30, 40, 48 Vdc are being applied to the charge plate, the Verifier measures the applied voltages five times and retrieves five CS110 electric field readings.

**Field Verification Sequence — Switch Sequence After the Public Variable
Start_Verify is set to true**

Step	Switches “On”	Command	Description
1		All_off	
2	5, 6, 7, 9	Red_Gnd_Neg	Test in Progress LED is on (9), VPlate and VCap are shorted to remove extraneous voltages (7), VPlate and Vcap are switched for negative voltages (VSW_H connected to VCap and VSW_L connected to VPlate 5 and 6)
3	5, 6, 9	Red_Neg	Test in Progress LED is on (9), VPlate and Vcap are switched for negative voltages (VSW_H connected to VCap and VSW_L connected to VPlate 5 and 6)
4	4, 5, 6, 9	V48_Neg	Test in Progress LED is on (9), VPlate and Vcap are switched for negative voltages (VSW_H connected to VCap and VSW_L connected to VPlate 5 and 6), 48 Vdc connected to VSW_H and VCap (4)
5	5, 6, 9	Red_Neg	Test in Progress LED is on (9), VPlate and Vcap are switched for negative voltages (VSW_H connected to VCap and VSW_L connected to VPlate 5 and 6)
6	3, 5, 6, 9	V40_Neg	Test in Progress LED is on (9), VPlate and Vcap are switched for negative voltages (VSW_H connected to VCap and VSW_L connected to VPlate 5 and 6), 40 Vdc connected to VSW_H and VCap (3)
7	5, 6, 9	Red_Neg	Test in Progress LED is on (9), VPlate and Vcap are switched for negative voltages (VSW_H connected to VCap and VSW_L connected to VPlate 5 and 6)
8	2, 5, 6, 9	V30_Neg	Test in Progress LED is on (9), VPlate and Vcap are switched for negative voltages (VSW_H connected to VCap and VSW_L connected to VPlate 5 and 6), 30 Vdc connected to VSW_H and VCap (2)
9	5, 6, 9	Red_Neg	Test in Progress LED is on (9), VPlate and Vcap are switched for negative voltages (VSW_H connected to VCap and VSW_L connected to VPlate 5 and 6)
10	1, 5, 6, 9	V16_Neg	Test in Progress LED is on (9), VPlate and Vcap are switched for negative voltages (VSW_H connected to VCap and VSW_L connected to VPlate 5 and 6), 16 Vdc connected to VSW_H and VCap (1)
11	5, 6, 9	Red_Neg	Test in Progress LED is on (9), VPlate and Vcap are switched for negative voltages (VSW_H connected to VCap and VSW_L connected to VPlate 5 and 6)
12	5, 6, 7, 9	Red_Gnd_Neg	Test in Progress LED is on (9), VPlate and VCap are shorted to remove extraneous voltages (7), VPlate and Vcap are switched for negative voltages (VSW_H connected to VCap and VSW_L connected to VPlate 5 and 6)
13	9	Red_Pos	Test in Progress LED is on (9), 5 and 6 are off so VPlate and Vcap are set for positive voltages (VSW_H connected to VPlate and VSW_L connected to VCap)

Step	Switches “On”	Command	Description
14	7, 9	Red_Gnd_Pos	Test in Progress LED is on (9), 5 and 6 are off so VPlate and Vcap are set for positive voltages (VSW_H connected to VPlate and VSW_L connected to VCap), VPlate and VCap are shorted
15	9	Red_Pos	Test in Progress LED is on (9), 5 and 6 are off so VPlate and Vcap are set for positive voltages (VSW_H connected to VPlate and VSW_L connected to VCap)
16	1, 9	V16_Pos	Test in Progress LED is on (9), 5 and 6 are off so VPlate and Vcap are set for positive voltages (VSW_H connected to VPlate and VSW_L connected to VCap), 16Vdc connected to VSW_H and VPlate (1)
17	9	Red_Pos	Test in Progress LED is on (9), 5 and 6 are off so VPlate and Vcap are set for positive voltages (VSW_H connected to VPlate and VSW_L connected to VCap)
18	2, 9	V30_Pos	Test in Progress LED is on (9), 5 and 6 are off so VPlate and Vcap are set for positive voltages (VSW_H connected to VPlate and VSW_L connected to VCap), 30 Vdc connected to VSW_H and VPlate (2)
19	9	Red_Pos	Test in Progress LED is on (9), 5 and 6 are off so VPlate and Vcap are set for positive voltages (VSW_H connected to VPlate and VSW_L connected to VCap)
20	3, 9	V40_Pos	Test in Progress LED is on (9), 5 and 6 are off so VPlate and Vcap are set for positive voltages (VSW_H connected to VPlate and VSW_L connected to VCap), 40 Vdc connected to VSW_H and VPlate (3)
21	9	Red_Pos	Test in Progress LED is on (9), 5 and 6 are off so VPlate and Vcap are set for positive voltages (VSW_H connected to VPlate and VSW_L connected to VCap)
22	4, 9	V48_Pos	Test in Progress LED is on (9), 5 and 6 are off so VPlate and Vcap are set for positive voltages (VSW_H connected to VPlate and VSW_L connected to VCap), 48 Vdc connected to VSW_H and VPlate (4)
23	9	Red_Pos	Test in Progress LED is on (9), 5 and 6 are off so VPlate and Vcap are set for positive voltages (VSW_H connected to VPlate and VSW_L connected to VCap)
24	7, 8	Green_Gnd_Pos	Test Ready LED is on (9), 5 and 6 are off so VPlate and Vcap are set for positive voltages (VSW_H connected to VPlate and VSW_L connected to VCap), VPlate and VCap are shorted to remove extraneous voltages (7)
25			End of verification process

If *Start Verify* is set to **FALSE** when the Verifier is outputting negative voltages, the following is done:

Step	Switches On	Command	Description
1	5, 6, 9	Red_Neg	Test in Progress LED is on (9), VPlate and Vcap are switched for negative voltages (VSW_H connected to VCap and VSW_L connected to VPlate 5 & 6)
2	7, 8	Green_Gnd_Pos	Test Ready LED is on (9), 5 & 6 are off so VPlate and Vcap are set for positive voltages (VSW_H connected to VPlate and VSW_L connected to VCap), VPlate and VCap are shorted to remove extraneous voltages (7)

If *Start Verify* is set to **FALSE** when the Verifier is outputting positive voltages, the following is done:

Step	Switches "On"	Command	Description
1	9	Red_Pos	Test in Progress LED is on (9), 5 & 6 are off so VPlate and Vcap are set for positive voltages (VSW_H connected to VPlate and VSW_L connected to VCap)
2	7, 8	Green_Gnd_Pos	Test Ready LED is on (9), 5 & 6 are off so VPlate and Vcap are set for positive voltages (VSW_H connected to VPlate and VSW_L connected to VCap), VPlate and VCap are shorted to remove extraneous voltages (7)

- The Verifier does a linear regression on the CS110 measurements (mV) and the applied electric fields (V/m) accounting for the effective distance from the test cover charge plate to the CS110 sense electrode. The result of the regression is a new **MPARALLEL PLATE** factor. **View Results** displays the original and new **MPARALLEL PLATE** factors and the percent change. If the change is greater than 4% (or a user-chosen percentage), clean the CS110, then carefully reinstall the CS110 stator and repeat the verification. If these steps don't reduce the change, either switch to the new **MPARALLEL PLATE** factor or return the CS110 to the factory for recalibration (refer to the [Assistance](#) page at the beginning of this manual for information about returning the Verifier). While not as critical, a clean CS110 *Verified Zero* result should be less than 6 V/m (assuming a **Csite** factor = 0.1).
- The Verifier stores the averages of the five measurements and five retrieved CS110 electric field readings in the final storage data table named **Calib**. Following is a **Calib** data sample from one verification.

TIMESTAMP	RECORD	Eplate_volts_Avg	EplateEfield_Avg	CS110_in_mV_Avg	Eplate_volts_Std	EplateEfield_Std	CS110_in_mV_Std	PakBuss_Addr	CS110_SN	Original_MPP	latitude_a	latitude_b	longitude_a	longitude_b
TS	RN	Avg	Avg	Avg	Std	Std	Std	Smp	Smp	Smp	degrees	minutes	degrees	minutes
10/4/2017 15:55	0	-47.66074	2282.602	27.15398	0	0	0.02555347	1	1030	85.4	41	45.94	-111	-51.31
10/4/2017 15:55	1	-39.75376	1903.916	22.53726	0	0	7.63E-07	1	1030	85.4	41	45.94	-111	-51.31
10/4/2017 15:55	2	-29.84952	1429.575	16.81416	0	0	0.02731781	1	1030	85.4	41	45.94	-111	-51.31
10/4/2017 15:55	3	-15.96443	764.58	8.741723	0	0	0	1	1030	85.4	41	45.94	-111	-51.31
10/4/2017 15:55	4	0	0	-0.5463577	0	0	2.38E-08	1	1030	85.4	41	45.94	-111	-51.31
10/4/2017 15:55	5	15.96443	-764.58	-9.766144	0	0	0	1	1030	85.4	41	45.94	-111	-51.31
10/4/2017 15:55	6	29.85499	-1429.837	-17.83175	0.006701561	0.3209573	0.01365891	1	1030	85.4	41	45.94	-111	-51.31
10/4/2017 15:55	7	39.75376	-1903.916	-23.60948	0	0	0.02731838	1	1030	85.4	41	45.94	-111	-51.31
10/4/2017 15:55	8	47.66074	-2282.602	-28.21254	0	0	0.01365891	1	1030	85.4	41	45.94	-111	-51.31

Following is an Excel regression of the above data. Its results differ slightly from the Verifier's results because the Excel regression uses the average of the

5 samples for each voltage and not the original 5 raw measurements for each applied voltage.

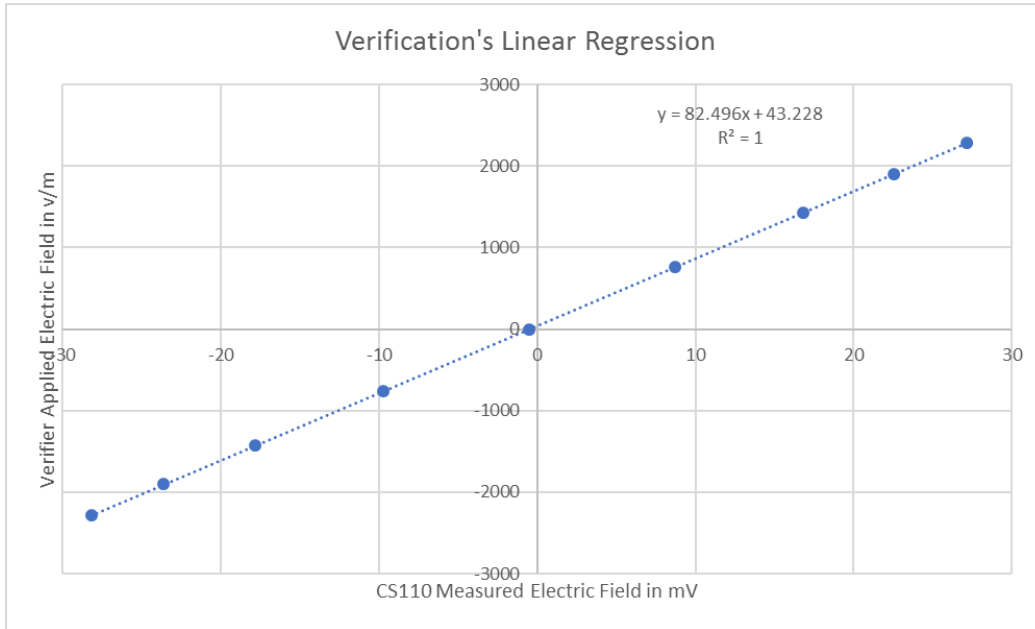

Following is the Verifier's results from the **Fit** data table.

TIMESTAMP	TS	10/4/2017 15:55
RECORD	RN	0
PakBus_Add		1
CS110Serial#		1030
Original_MPP		85.38
Verified_MPP		82.4767
MPP_%_Change		-3.4
Verified_R2		0.9999052
Verified_Offset		37.89066
VerifiedZero		-4.665
Csite		0.1
Plate_Distance_m		0.02088
latitude_a	degrees	41
latitude_b	minutes	45.94
longitude_a	degrees	-111
longitude_b	minutes	-51.31
Satellites	unitless	6

- Upon completion of the verify process, the **Start Verify** flag is set to **FALSE**, the Test in Progress LED is turned off, and the Test Ready LED is turned on.

B.2 SDM-CD16AC Relay Switch Functions

See Appendix C, *Verifier Calibration Uncertainty (p. C-1)*, for additional details (COM = Common, NO = Normally Open, NC = Normally Closed).

Switch	Position	Description	Purpose
1	Off		Disconnects 16 Vdc from VPlate or VCap
1	On	V16 connected to VSW_H	Connects 16 Vdc to VPlate or VCap
2	Off		Disconnects 30 Vdc from VPlate or VCap
2	On	V30 connected to VSW_H	Connects 30 Vdc to VPlate or VCap
3	Off		Disconnects 40 Vdc from VPlate or VCap
3	On	V40 connected to VSW_H	Connects 40 Vdc to VPlate or VCap
4	Off		Disconnects 48 Vdc from VPlate or VCap
4	On	V48 connected to VSW_H	Connects 48 Vdc to VPlate or VCap
5	Off	VSW_H connected to VPlate	Switches to Positive voltages (5 & 6 at same time, 1-4 should be off)
5	On	VSW_H connected to VCap	Switches to Negative voltages (5 & 6 at same time, 1-4 should be off)
6	Off	VSW_L connected to VCap	Switches to Positive voltages (5 & 6 at same time, 1-4 should be off)
6	On	VSW_L connected to VPlate	Switches to Negative voltages (5 & 6 at same time, 1-4 should be off)
7	Off		Unshort VCap from VPlate
7	On	VPlate connected to VCap	Short VCap to VPlate to remove residual voltage (1-4 must be Off)
8	Off		Not ready to verify
8	On	Powers Test Ready LED	Indicates when the verification test is ready to start
9	Off		Not verifying
9	On	Powers Test in Progress LED	Indicates that the verification test is in progress

B.3 Current Drain at Different Stages in the Verification Process

140 mA	GPS off, display off, verify process off
330 mA	GPS off, display off, verify process on
310-440 mA	GPS off, display on, verify process off
650 mA	GPS off, display on, verify process on
670 mA	GPS on, display on, verify process on
320 mA	GPS on, display on, verify process off
360 mA	GPS on, display off, verify process on
160 mA	GPS on, display off, verify process off
225 mA	display on, GPS off, green LED on, 48 Vdc power supply off, 0 Vdc output
410 mA	display on, GPS off, red LED on, 48 Vdc power supply on, -48 Vdc output
335 mA	display on, GPS off, red LED on, 48 Vdc power supply on, 0 Vdc output
340 mA	display on, GPS off, red LED on, 48 Vdc power supply on, +48 Vdc output
220 mA	display on, GPS off, green LED on, 48 Vdc power supply off, 0 Vdc output
95 mA	display off, GPS off, green LED on, 48 Vdc power supply off, 0 Vdc output
25 mA	display off, GPS off, green LED off, 48 Vdc power supply off, 0 Vdc output
240 mA	display on, GPS on, green LED on, 48 Vdc power supply off, 0 Vdc output
425 mA	display on, GPS on, red LED on, 48 Vdc power supply on, -48 Vdc output
345 mA	display on, GPS on, red LED on, 48 Vdc power supply on, 0 Vdc output
345 mA	display on, GPS on, red LED on, 48 Vdc power supply on, +48 Vdc output
240 mA	display on, GPS on, green LED on, 48 Vdc power supply off, 0 Vdc output
105 mA	display off, GPS on, green LED on, 48 Vdc power supply off, 0 Vdc output
45 mA	display off, GPS on, green LED off, 48 Vdc power supply off, 0 Vdc output

25 mA	CR1000
15 mA	GPS
250 mA	13 Vdc power supply for SDM-CD16AC
127 mA	48 Vdc power supply
135 mA	display
7 mA	voltage divider load
70 mA	1 switch and 1 LED
80 mA	2 additional switches (negative voltages)

The Verifier was placed on Campbell Scientific’s shaker table to simulate field use and travel conditions. After adding and securing a Velcro strap to hold in the alkaline D cells the Verifier survived the test. The following show the test the Verifier was subjected to.

1. Select Vibration Type (Fixed, Profile, Sweep):

Fixed Freq. Freq.(Hz) G (Peak) level desired:

Profile of Freq's.

Clear Table BreakPoint Table

BreakPoint	Start Freq	*Amplitude (G/in)	End Freq	Amplitude
1	5	.2 inch	14	
2	14	2 g	33	
3	33	2g	52	
4	52	2g	200	

Profile Sweep Rate Update Graph

Sweeps Start Freq Stop Freq Duration (secs) Input V

2. Run it

3. Monitor Results (profile only) Approximate
Calculated Profile time (minutes):

Sine Acceleration Profile

G Peak

Frequency

Frequency: Target G-Peak

SYSDVM NOT found
Activity Monitor
FGEN NOT found

8:53 AM

Appendix C. Verifier Calibration Uncertainty

Uncertainty Analysis of the Calibration of a CS110FV In-Field Verifier System

Abstract: We present the uncertainty analysis for the calibration of an electric field meter calibration verification system model CS110FV In-Field Verifier. The uncertainty analysis incorporates contributions from the calibration of the CS110 used to calibrate the Verifier's test cover; the measurement of the DC voltage applied by a 12 Vdc to 48 Vdc DC/DC converter; type A measurement uncertainty; and uncertainty associated with operator variation, including cable arrangement, electrical connections, and variations in the attachment of the test cover to the calibrating CS110.

1. Introduction

Electric field mills/meters measure the potential gradients associated with atmospheric electric fields. Field mill networks can be used for early warning lightning detection systems that indicate when operational activities must be halted due to hazardous weather conditions. Examples of electric field mill networks include the Kennedy Space Center Advanced Ground Based Field Mill Network¹ and the Lightning and Potential Gradient Warning Systems at Sandia National Laboratories².

One common electric field mill design is the rotational field mill. Rotational field mills operate by exposing electrodes on a sensor to an electric field through a spinning shutter that is electrically grounded³. The electric field induces charge on the sensor's electrodes while the shutter is open, and the charge dissipates as the shutter closes. An alternating current signal proportional to the strength of the electric field is generated as the shutter rotates. The CS110 field meter used in this work uses a reciprocating shutter instead of the traditional rotating vane field mill. The reciprocating shutter is electrically connected to ground potential by a flexible stainless-steel strap. The strap operates below its fatigue limit, resulting in an ultra-reliable electrical ground connection to the shutter. In this work, we present the uncertainty analysis for a system designed to verify the calibration of a reciprocating shutter electric field meter with a test uncertainty ratio (TUR) greater than or equal to 4:1.

A field meter's calibration can be verified by using it to measure a known electric field. Electric fields are calculated as voltage per unit distance, so the ideal verification system exposes the sensor electrodes to several constant voltages at a constant distance. The calibration system under consideration incorporates a 316L stainless steel parallel plate test cover built by Campbell Scientific in which an electrically isolated charge plate is held at a fixed distance of approximately 30 mm from the field mill's sense electrode. A 12 Vdc to 48 Vdc DC/DC converter is used to apply voltage to the charge plate. The test cover is placed on the field meter so the sense electrode is parallel to the charge plate. The Verifier measures the applied DC voltage and the field meter measures the electric field generated by the charge plate over a range of applied voltages (-48, -40, -30, -16, 0, 16, 30, 40, 48).

The uncertainty analysis of the Verifier will focus on uncertainty of the CS110 used to calibrate the Verifier's test cover, the measurement of the voltage produced by the DC/DC converter, as well as contributions to uncertainty made by operator variability and type A measurement uncertainty.

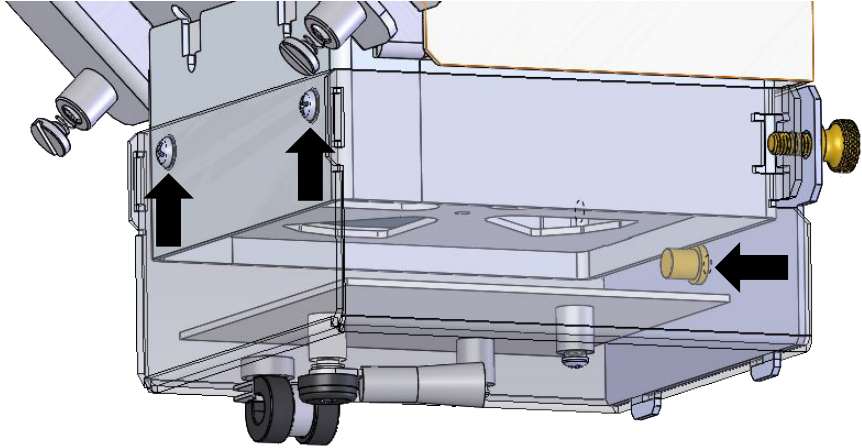

FIGURE C-1. Test cover installed on the CS110. Arrows indicate the installation alignment points.

2. Uncertainty Analysis

The uncertainty analysis of the Verifier is calculated as the root sum square of uncertainties associated with measurement variability (*Type A* uncertainties) and system component uncertainties (*Type B*)⁴. Measurement variability encompasses the distribution of *effective distance* values repeatedly measured by the Verifier connected to the calibrated CS110. System uncertainties are attributed to the reference CS110 calibration uncertainty, the variability inherent to the Verifier's measurement of the voltage output sourced from the DC/DC converter, and to changes in setup due to operator variability, such as changes in cabling, electrical connections, and variation in mounting the test cover onto the CS110 field meter. In this section, we discuss the measurement and calculation of each contribution to uncertainty.

2.1 CS110 Calibration Uncertainty

Initial calibration of several Verifier test covers using reference CS110s revealed that the Verifier applied electric fields (computed from the applied voltage divided by the distance from the test cover charge plate to the CS110 sense electrode) didn't match the electric fields measured by the CS110. We believe that this is due to what are called fringe effects caused by the 30 mm separation distance. To compensate for the fringe effects a calibrated CS110 is used to determine a test cover's effective distance in the place of the measured distance. Thus, the uncertainty of the reference CS110 calibration becomes a system uncertainty.

Campbell Scientific⁵ specifies a CS110 calibration uncertainty of $\pm 1\%$ of reading + 60 V m⁻¹. Recent work by Elizabeth Auden⁶ found the CS110 calibration uncertainty to be 0.72%, corresponding to a confidence level of 95.45%. Because all contributing uncertainties should be expressed at the same

standard uncertainty ($k = 1$ or 68%), 0.36% will be used for the CS110 calibration uncertainty in TABLE C-1.

2.2 Voltage Uncertainty

The output of the DC/DC converter is applied to the charge plate of the test cover and a uniform charge distribution is assumed. The DC/DC converter's applied voltage is measured by a CR1000 datalogger embedded inside the Verifier utilizing a 10 to 1 voltage divider. The verifier is calibrated when the temperature is between 0°C and +40°C, so the measurement of the voltage by CR1000 is certified by the manufacturer to measure the maximum expected voltage of 4800 mV with an accuracy of $\pm 0.14\%$ ($=4800\text{mV} * .0006 + 3 * 1.333\text{mV} + .003\text{mV}$). The 10 to 1 voltage divider has a ratio tolerance of 0.02% at 25°C. Combined, the root sum of squares error is 0.14%.

2.3 Operator Variability

The *Effective Distance* was measured 10 times, each time removing the test cover and cables and reinstalling them. The data is shown in the following table. The average value of the *Effective Distance* was 0.02069 mm with a standard deviation of 0.00001246 m, or uncertainty of 0.060%.

TIMESTAMP	CS110Serial#	Original_MPP	Verified_MPP	MPP_%_Change	Verified_R2	Verified_Offset	VerifiedZero	Csite	Plate_Distance_m	Effective Distance
TS										meters
10/18/2017 10:53	1021	87.33	1.806008	-97.9	0.9999986	0.341908	-1.831	0.1	1	0.02068027
10/18/2017 10:56	1021	87.33	1.806197	-97.9	1	0.3418536	-1.772	0.1	1	0.020682434
10/18/2017 11:00	1021	87.33	1.80631	-97.9	1	0.3429356	-1.772	0.1	1	0.020683728
10/18/2017 11:04	1021	87.33	1.8066	-97.9	0.9999982	0.3502259	-1.772	0.1	1	0.020687049
10/18/2017 11:07	1021	87.33	1.806211	-97.9	1	0.3358769	-1.772	0.1	1	0.020682595
10/18/2017 11:11	1021	87.33	1.808158	-97.9	0.999999	0.3468041	-1.772	0.1	1	0.020704889
10/18/2017 11:15	1021	87.33	1.809253	-97.9	1	0.3452721	-1.772	0.1	1	0.020717428
10/18/2017 11:18	1021	87.33	1.808091	-97.9	0.999998	0.3347926	-1.772	0.1	1	0.020704122
10/18/2017 11:24	1021	87.33	1.80682	-97.9	0.9999996	0.3360648	-1.772	0.1	1	0.020689568
10/18/2017 11:28	1021	87.33	1.806639	-97.9	1	0.3382649	-1.772	0.1	1	0.020687496
									average	0.020691958
									std dev	1.24559E-05
									percent	0.060196722

2.4 Type A Measurement Uncertainty of the *Effective Distance*

The *Effective Distance* was measured 10 times without changing the setup. The data is shown in the following table. The average value of the *Effective Distance* was 0.02069 m with a standard deviation of 0.000005639 m, or uncertainty of 0.027%.

TIMESTAMP	CS110Serial#	Original_MPP	Verified_MPP	MPP_%_Change	Verified_R2	Verified_Offset	VerifiedZero	Csite	Plate_Distance_m	Effective Distance
TS										meters
10/18/2017 10:09	1021	87.33	1.80762	-97.9	0.9999852	0.3074072	-1.773	0.1	1	0.020698729
10/18/2017 10:14	1021	87.33	1.807237	-97.9	0.9999997	0.3375697	-1.773	0.1	1	0.020694343
10/18/2017 10:16	1021	87.33	1.806586	-97.9	1	0.3322515	-1.772	0.1	1	0.020686889
10/18/2017 10:18	1021	87.33	1.807115	-97.9	1.000001	0.3441038	-1.772	0.1	1	0.020692946
10/18/2017 10:21	1021	87.33	1.807029	-97.9	1	0.3413177	-1.772	0.1	1	0.020691962
10/18/2017 10:24	1021	87.33	1.806521	-97.9	1	0.3396497	-1.832	0.1	1	0.020686145
10/18/2017 10:26	1021	87.33	1.806571	-97.9	0.9999989	0.3368526	-1.772	0.1	1	0.020686717
10/18/2017 10:28	1021	87.33	1.806439	-97.9	0.9999987	0.3411918	-1.772	0.1	1	0.020685206
10/18/2017 10:31	1021	87.33	1.806533	-97.9	0.9999975	0.348402	-1.772	0.1	1	0.020686282
10/18/2017 10:36	1021	87.33	1.8059	-97.9	0.9999979	0.334064	-1.772	0.1	1	0.020679034
									avg	0.020688825
									std	5.63896E-06
									percent	0.027256045

3. Results

TABLE C-1 presents the contributions to uncertainty in the CS110FV In-Field Verifier system. The uncertainties associated with the CS110 calibration and the voltage measurement, along with the type A measurement uncertainty and uncertainties contributed by operator variability, are added in quadrature to calculate the total system uncertainty of 0.78% at $k(\text{Coverage factor}) = 2$.

TABLE C-1. Uncertainty in CS110FV In-Field Verifier System	
Cause of Uncertainty	Contribution to Uncertainty
CS110 calibration	0.36%
Voltage measurement	0.14%
Operator variability (cords, connectors, test cover installation)	0.060%
Type A measurement	0.027%
Standard uncertainty at $k = 1$	0.39%
Expanded uncertainty at $k = 2$	0.78%

4. Conclusion

The Verifier’s calibration uncertainty is 0.78%, corresponding to a confidence level of 95%. Therefore, the Verifier is able to calibrate CS110 electric field meters with a tolerance better than 3.1%, assuming the standard test uncertainty ratio (TUR) of 4:1.

5. References

M. F. Stewart and L. R. Barnum, *Maintenance Manual for the Advanced Ground-Based (Electric) Field Mill Instrument*, Vol. 1 and 2, March 26, 1993.

W. H. Beasley and L. G. Byerley III, “Evaluation of the Lightning and Potential Gradient Warning Systems at SNL/NM,” Report Version 2.4, Sept. 30th, 2010.

K. L. Kaiser, *Electrostatic Discharge*, CRC Press, Taylor & Francis Group, Boca Raton, FL, 2006.

B. N. Taylor and C. E. Kuyatt, “NIST Technical Note 1297: Guidelines for Evaluating and Expressing the Uncertainty of NIST Measurement Results,” National Institute of Standards and Technology, 1994 ed.

Campbell Scientific, Inc., “CS110 Electric Field Meter Instruction Manual,” Revision 4/12, 2012.

E.C. Auden, J. J. Novak, R.W. Salazar, and A. Hinckley, “Uncertainty Analysis of an Electric Field Mill Calibration System,” NCSL International Workshop & Symposium, Precision & Performance with Measurement Science, August 13 – 17, 2017, National Harbor, MD.

Campbell Scientific Worldwide Offices

Australia

Location: Garbutt, QLD Australia
Email: info@campbellsci.com.au
Website: www.campbellsci.com.au

Brazil

Location: São Paulo, SP Brazil
Email: andread@campbellsci.com.br
Website: www.campbellsci.com.br

Canada

Location: Edmonton, AB Canada
Email: dataloggers@campbellsci.ca
Website: www.campbellsci.ca

China

Location: Beijing, P. R. China
Email: info@campbellsci.com.cn
Website: www.campbellsci.com.cn

Costa Rica

Location: San José, Costa Rica
Email: info@campbellsci.cc
Website: www.campbellsci.cc

France

Location: Antony, France
Email: info@campbellsci.fr
Website: www.campbellsci.fr

Germany

Location: Bremen, Germany
Email: info@campbellsci.de
Website: www.campbellsci.de

South Africa

Location: Stellenbosch, South Africa
Email: sales@csafrica.co.za
Website: www.campbellscientific.co.za

Southeast Asia

Location: Bangkok, Thailand
Email: info@campbellsci.asia
Website: www.campbellsci.asia

Spain

Location: Barcelona, Spain
Email: info@campbellsci.es
Website: www.campbellsci.es

UK

Location: Shepshed, Loughborough, UK
Email: sales@campbellsci.co.uk
Website: www.campbellsci.co.uk

USA

Location: Logan, UT USA
Email: info@campbellsci.com
Website: www.campbellsci.com

Please visit www.campbellsci.com/contact to obtain contact information for your local US or international representative.