

**NON-CONFIDENTIAL BUSINESS INFORMATION  
(Non-CBI)**

# **Certification Test Report**

## **Hearth & Home Technologies Freestanding Wood Stove Model: Explorer I**

**Prepared for:** Hearth & Home technologies  
1445 North Highway  
colville, WA. 99114

**Prepared by:** OMNI-Test Laboratories, Inc.  
13327 NE Airport Way  
Portland, OR 97230  
(503) 643-3788

**Test Period:** September 28, 2015 – October 1, 2015

**Report Date:** October 20, 2015

**Revised Report Date:** March 9, 2016

**Report Number:** 0061WS091E

*All data and information contained in this report are confidential and proprietary to Hearth & Home Technologies. Its significance is subject to the adequacy and representative character of the samples and to the comprehensiveness of the tests, examinations, or surveys made. The contents of this report cannot be copied or quoted, except in full, without specific, written authorization from Hearth & home Technologies and OMNI-Test Laboratories, Inc. No use*

## AUTHORIZED SIGNATORIES

This report has been reviewed and approved by the following authorized signatories:

### Technician:



Bruce Davis, Technician  
OMNI-Test Laboratories, Inc.

### QA Review:



Alex Tiegs, QA Administrator  
OMNI-Test Laboratories, Inc.

### Evaluation Decision:



Sebastian Button, Testing Supervisor  
OMNI-Test Laboratories, Inc.

March 9, 2016  
Issue Date

## TABLE OF CONTENTS

	PREFACE.....	(3 pages)
1.	SAMPLING PROCEDURES AND TEST RESULTS .....	4
	Introduction.....	5
	Sampling Procedure .....	5
	Summary of Results .....	5
	Category I Burn Rate Rationale.....	6
	 <u>Summary Tables</u>	
	Table 1.1a - Particulate Emissions Results .....	7
	Table 1.1b - Particulate Emissions Results (First Hour).....	7
	Table 1.1c – Carbon Monoxide Emissions .....	7
	Table 1.1d – Efficiency.....	8
	Table 1.2 - Test Facility Conditions .....	8
	Table 1.3.1 - Fuel Measurements and Crib Descriptions - Pretest .....	8
	Table 1.3.2 - Fuel Measurements and Crib Descriptions - Test .....	9
	Table 1.4 - Dilution Tunnel Gas Measurements and Sampling Data .....	9
	Table 1.5 –Average temperature Data .....	9
	Table 1.6 - Pretest Configurations .....	10
	Table 1.7 - Test Configurations .....	11
2.	FUEL PHOTOGRAPHS/APPLIANCE DESCRIPTION/DRAWINGS.....	12
	Appliance Photographs.....	13
	Fuel Photographs .....	14
	Appliance Description .....	17
3.	QUALITY ASSURANCE/QUALITY CONTROL .....	19
	Quality Assurance Plan.....	21
	Sample Analysis.....	22
	Calibrations – Methods EPA 28R, ASTM E2515, & ASTM E2780 .....	34
	Example Calculations .....	54
4.	OWNER’S MANUAL.....	70
5.	TEST DATA BY RUN.....	120
	Run 1 .....	124
	Run 2.....	135
	Run 3.....	147
	Run 4.....	158
	Run 5.....	169

*Model: Explorer I  
Hearth & Home technologies  
1445 North Highway  
Colville, WA 99114*

# **Section 1**

## **Sampling Procedures and Test Results**



## INTRODUCTION

Hearth & Home technologies retained *OMNI* to perform U.S. Environmental Protection Agency (EPA) certification testing on the Explorer I wood stove. Woodstove model Explorer I is a non-catalytic, freestanding, radiant-type room heater. The firebox is constructed of both mild steel and cast iron. Usable firebox volume was measured to be 1.68 cubic feet and the stove is vented through a 6-inch diameter flue collar located at the top of the unit.

Testing was performed at Hearth & Home testing facility in Colville WA. Altitude of the laboratory is 1635 feet above sea level. The unit was received in good condition and logged in on September 28, 2015, then assigned and labeled with *OMNI* ID #2135. *OMNI* representative Bruce Davis conducted certification testing and completed all testing by October 1, 2015.

This report is organized in accordance with the EPA-recommended outline and is summarized in the Table of Contents immediately preceding this section. Results in this report are limited to the item(s) submitted.

## SAMPLING PROCEDURE

Hearth & Home technologies woodstove model Explorer I was tested in accordance with the U.S. EPA 40 CFR Part 60, Subpart AAA – Standards of Performance for New Residential Wood Heaters using EPA Method 28R, ASTM E2515 and ASTM E2780. Particulate emissions were measured using dual sampling trains consisting of two filters (front and back). Woodstove model Explorer I was tested for thermal efficiency and carbon monoxide (CO) emissions in accordance with CSA B415.1-10.

## TEST RUN SUMMARY

**Run 1** – Category 2 burn rate (0.86 kg/hr), no anomalies occurred, valid test run included in weighed average.

**Run 2** - Category 2 burn rate (0.92 kg/hr), no anomalies occurred, valid test run included in weighed average.

**Run 3** - Category 4 burn rate (2.45 kg/hr), no anomalies occurred, valid test run included in weighed average.

**Run 4** - Category 3 burn rate (1.57 kg/hr), no anomalies occurred, valid test run included in weighed average.

**Run 5** - Category 2 burn rate (0.91 kg/hr), no anomalies occurred, valid fan confirmation test run not included in weighed average.

## SUMMARY OF RESULTS

Weighted average emissions of the five test runs included in the results indicate a particulate emission rate of 2.2 grams per hour. Run 5, a fan confirmation test run was not used in the weighted average emission results. Emissions results of the Explorer I are within emission limit of 4.5 g/hr for affected facilities manufactured on or after May 15, 2015, or sold at retail after December 31, 2015. Proportionality results for all five test runs were acceptable. Quality check results for each test run are presented in Section 2 of this report.

## CATEGORY 1 BURN RATE RATIONALE

EPA Method 28 section 8.1.1.3.2 states the following:

*Evidence that a wood heater cannot be operated at a burn rate less than 0.80 kg/hr shall include documentation of two or more attempts to operate the wood heater in burn rate Category 1 and fuel combustion has stopped, or results of two or more test runs demonstrating that the burn rates were greater than 0.80 kg/hr when the air supply controls were adjusted to the lowest possible position or settings... NOTE: After July 1, 1990, if a wood heater cannot be operated at a burn rate less than 0.80 kg/hr, at least one test run with an average burn rate of 1.00 kg/hr or less shall be conducted.*

The U.S. Environmental Protection Agency Applicability Determination Index, under Control Number WDS-109, states the following regarding this requirement of Method 28:

*The purpose of this requirement is to ensure that a good-faith effort has been made to achieve a Category 1 burn rate. However, if the air supply control is tamper-proof, EPA will accept one test as adequate documentation that the stove cannot achieve a Category 1 burn rate. Note that this applies only to stoves which do not reach the low burn rate because of limits on the air supply; manufacturers of stoves which cannot sustain a burn rate at lower air settings will still be required to submit documentation of two or more attempts. In all cases, a test series consisting of at least four runs is required.*

As the Run Notes in Section 5 and Table 1.1a in Section 1 of this report show, Run 1, was operated at a burn-rate of less than 1.0 kg/hr with the combustion air inlet open 1.28" from full closed, this setting is factory set with a mechanical stop at full closed. Air controls for this heater are considered to be tamper-proof. When tested in accordance with EPA Method 28 the heater cannot be induced to operate at a burn rate less than 0.80 kg/hr therefore Run 1 fulfills the requirements of the standard.

**Table 1.1a – Particulate Emissions**

<b>Run</b>	<b>Burn Rate (kg/hr dry)</b>	<b>ASTM E2515 Emissions (g/hr)</b>
1	0.86	1.11
2	0.92	1.19
3	2.45	3.83
4	1.57	2.90
1 <sup>5</sup>	0.91	1.85
Weighted particulate emission average of four tests: <b>2.2</b> grams per hour.		

1. Run 5 is a fan confirmation and not included in the weighted average.

**Table 1.1b – Particulate Emissions (First Hour)**

<b>Run</b>	<b>ASTM E2515 Emissions – First Hour (g/hr)</b>
1	4.20
2	4.01
3	6.75
4	7.37
5	7.06

**Table 1.1c – Carbon Monoxide Emissions**

<b>Run</b>	<b>Carbon Monoxide g/MJ output</b>	<b>Carbon Monoxide g/kg Dry Fuel</b>	<b>Carbon Monoxide g/hour</b>
1	5.31	80.30	67.90
2	5.44	81.72	73.50
3	4.82	67.76	162.64
4	6.22	89.55	138.51
5	6.90	101.12	89.90

**Table 1.1d – Efficiency Data**

<b>Run</b>	<b>Burn Rate kg/hr</b>	<b>Heat Output Rate (BTU/hr)</b>	<b>Efficiency HHV %</b>	<b>Efficiency LHV %</b>
1	0.86	12,129	76.3	82.5
2	0.92	12,820	75.8	82.0
3	2.45	31,944	70.9	76.7
4	1.57	21,128	72.7	78.6
5	0.91	12,365	74.0	80.0
<b>Weighted Average</b>			74.1	80.1

**Table 1.2 – Test Facility Conditions**

<b>Run</b>	<b>Room Temperature (°F)</b>		<b>Barometric Pressure (Hg)</b>		<b>Air Velocity (ft/min)</b>	
	<b>Before</b>	<b>After</b>	<b>Before</b>	<b>After</b>	<b>Before</b>	<b>After</b>
1	76	81	28.60	28.52	<50	<50
2	71	79	28.53	28.42	<50	<50
3	77	81	28.48	28.48	<50	<50
4	82	84	28.45	28.43	<50	<50
5	76	79	28.48	28.41	<50	<50

**Table 1.3.1 – Fuel Measurement and Crib Description Summary – PRETEST**

<b>Run</b>	<b>Pretest Fuel Weight (Starting weight in lbs)</b>	<b>Pretest Moisture (Dry basis - %)</b>	<b>Coal Bed Weight (lbs)</b>
1	5.2	22.85	2.7
2	5.3	19.76	2.9
3	12.5	20.07	3.0
4	6.0	22.40	2.6
5	5.1	24.07	2.7

**Table 1.3.2 – Fuel Measurement and Crib Description Summary – TEST**

Run	Test Fuel Wet Basis (lbs)	Firebox Volume (ft <sup>3</sup> )	Fuel Loading Density Wet Basis (lbs/ft <sup>3</sup> )	Test Fuel Dry Basis (lbs)	Piece Length (in)	2x4s Used	4x4s Used
1	11.7	1.68	7.01	9.8	13	3	2
2	12.0	1.68	7.19	10.1	13	3	2
3	12.5	1.68	7.49	10.3	13	3	2
4	12.5	1.68	7.44	10.4	13	3	2
5	11.1	1.68	6.57	9.4	13	3	2

**Table 1.4 – Dilution Tunnel Gas Measurements and Sampling Data Summary**

Run	Length of Test (min)	Average Dilution Tunnel Gas Measurements		
		Velocity (ft/sec)	Flow Rate (dscf /min)	Temperature (°F)
1	310	17.14	182.7	85
2	300	16.63	177.1	84
3	115	17.11	177.1	100
4	180	17.13	175.7	104
5	280	16.81	177.9	87

**Table 1.5 - Average Temperature Data**

Run	Beginning Surface Temperature Average <sup>a</sup>	Ending Surface Temperature Average <sup>a</sup>	Surface Delta T <sup>b</sup>
1	334.2	231.8	102.4
2	335.7	230.1	105.6
3	478.5	429.8	48.7
4	361.9	320.5	41.4
5	353.8	329.6	24.2

a. All temperatures are in degrees F.

b. Represents the difference between beginning and ending average surface temperatures.

**Table 1.6 – Pretest Configuration**

<b>Run</b>	<b>Combustion Air</b>	<b>Fuel Added</b>	<b>Fuel Removed</b>	<b>Time (min)</b>
1	Fully Closed	5.2 lbs at start; no addition; coal bed 2.7 lbs	None	60
2	Control arm at 72.41 degrees; see drawing shown in run notes.	5.3 lbs at start; no addition; coal bed 2.9 lbs	None	60
3	Fully Open, boost air locked open.	12.5 lbs at start; no addition; coal bed 3.0 lbs	None	65
4	Fully open	6.0 lbs at start; no addition; coal bed 2.6 lbs	0.4 lbs. at 45 minutes	60
5	Fully Closed	5.1 lbs at start; ; no addition; coal bed 2.7 lbs	None	80

**Table 1.7 – Test Configurations**

<b>Run</b>	<b>Five-Minute Startup</b>	<b>Combustion Air</b>
1	<u>Fuel Loading:</u> Done by 0:47. <u>Door:</u> Closed at 1:00. <u>Boost Air:</u> Pushed in at 0 minutes, pulled out to set at 60 seconds. <u>Primary Air:</u> At test setting entire test <u>Secondary:</u> Fixed. <u>Fan:</u> Off for the first 30 minutes then turned to high.	Fully Closed (1.277")
2	<u>Fuel Loading:</u> Done by 1:15. <u>Door:</u> Closed at 1:30. <u>Boost Air:</u> Pushed in at 0 minutes, pulled out to set at 60 seconds. <u>Primary Air:</u> At test setting entire test. <u>Secondary:</u> Fixed. <u>Fan:</u> Off for the first 30 minutes then turned to high.	Control arm set at 72.41degrees; see drawing in run notes.
3	<u>Fuel Loading:</u> Done by 0:40. <u>Door:</u> Closed at 0:50. <u>Boost Air:</u> Pushed in at 0 minutes, leaving the control pushed in locks it open.. <u>Primary Air:</u> Fully open for the entire test. <u>Secondary:</u> Fixed. <u>Fan:</u> On high the entire test.	Fully Open
4	<u>Fuel Loading:</u> Done by 0:50. <u>Door:</u> Closed at 0:60. <u>Boost Air:</u> Pushed in at 0 minutes, pulled out to set at 60 seconds. <u>Primary Air:</u> At test setting entire test. <u>Secondary:</u> Fixed. <u>Fan:</u> Off for the first 30 minutes then turned to high.	Fully Open
5	<u>Fuel Loading:</u> Done by 0:49. <u>Door:</u> Closed at 0:60. <u>Boost Air:</u> Pushed in at 0 minutes, pulled out to set at 60 seconds. <u>Primary Air:</u> At test setting entire test. <u>Secondary:</u> Fixed. <u>Fan:</u> Off for the entire test.	Fully Closed

*Model: Explorer I  
Hearth & Home technologies  
1445 North Highway  
Colville, WA 99114*

## **Section 2**

### **Fuel Photographs/Appliance Description/Drawings**



Model: Explorer I  
Hearth & Home technologies  
1445 North Highway  
Colville, WA 99114

**Hearth & Home technologies**  
**Explorer I**  
**Test Dates: September 28 – October 1, 2015**



Model: Explorer I  
Hearth & Home technologies  
1445 North Highway  
Colville, WA 99114

## Hearth & Home technologies Explorer I

**Run 1 – Fuel**



**Run 1 – Newly Loaded Stove**



**Run 2 – Fuel**



**Run 2 – Newly Loaded Stove**



Model: Explorer I  
Hearth & Home technologies  
1445 North Highway  
Colville, WA 99114

## Hearth & Home technologies Explorer I

**Run 3 – Fuel**



**Run 3 – Newly Loaded Stove**



**Run 4 – Fuel**



**Run 4 – Newly Loaded Stove**



*Model: Explorer I  
Hearth & Home technologies  
1445 North Highway  
Colville, WA 99114*

**Run 5 – Fuel**



**Run 5 – Newly Loaded Stove**





## WOOD HEATER DESCRIPTION

**Appliance Manufacturer:** Hearth & Home technologies

**Wood Stove Model:** Explorer I

**Type:** Freestanding, radiant-type room heater

## WOOD HEATER INFORMATION

**Materials of Construction:** The unit is constructed of mild steel and cast iron. The firebox is lined with Pumice firebrick with varying measurements (see drawing 7062-004). The feed door has a 5mm thick glass panel with 1/8" knit tape gasket, and a 1/2-inch rope wire jacket gasket mounted in the face of the appliance.

**Air Introduction System:** Combustion air is controlled by a handle located on the front of the appliance. A second control located on the front/right of the appliance activates a timer providing additional air to the lower primary air orifice for a predetermined length of time. This same control can be pushed in and set to allow additional air to the lower primary air orifice bypassing the timer. Secondary air is supplied by a third opening that has no user control.

**Combustion Control Mechanisms:** The combustion air inlet is controlled by a handle located below the fuel-loading door in the center of the appliance. A second air control activates a timer that when set slowly closes off an air opening supplying air to the lower primary air orifice.

**Combustor:** N/A

**Internal Baffles:** A baffle constructed of C-cast is mounted in the upper portion of the firebox; a ceramic blanket is laid on top of the baffle for insulation. The flame path is forced to the front of the firebox where it travels up through the opening between the baffle and primary air manifold.

**Other Features:** Optional 150 cubic feet per minute fan accessory can be mounted to the rear heat shield.

**Flue Outlet:** The 6-inch diameter flue outlet is located in the top of the unit.

## WOOD HEATER OPERATING INSTRUCTIONS

**Specific Written Instructions:** See Section 4 of this report. All markings and instruction materials were reviewed for content prior to printing.

*Model: Explorer I  
Hearth & Home technologies  
1445 North Highway  
Colville, WA 99114*

## **Engineering Drawings/Blueprints [Redacted]**

*Model: Explorer I  
Hearth & Home technologies  
1445 North Highway  
Colville, WA 99114*

## **Section 3**

### **Quality Assurance/Quality Control**

## QUALITY ASSURANCE/QUALITY CONTROL

OMNI follows the guidelines of ISO/IEC 17025, “General Requirements for the Competence of Testing and Calibration Laboratories,” and the quality assurance/quality control (QA/QC) procedures found in OMNI’s Quality Assurance Manual.

OMNI’s scope of accreditation includes, but is not limited to, the following:

- ANSI (American National Standards Institute) for certification of product to safety standards.
- To perform product safety testing by the International Accreditation Service, Inc. (formerly ICBO ES) under accreditation as a testing laboratory designated TL-130.
- To perform product safety testing as a “Certification Organization” by the Standards Council of Canada (SCC).
- Serving as a testing laboratory for the certification of wood heaters by the U.S. Environmental Protection Agency.

This report is issued within the scope of OMNI’s accreditation. Accreditation certificates are available upon request.

The manufacturing facilities and quality control system for production of the model Explorer I at Hearth & Home technologies was evaluated to determine if sufficient to maintain conformance with OMNI’s requirements for product certification. OMNI has concluded that the manufacturing facilities, processes, and quality control system are adequate to produce the appliance congruous with the standards and model codes to which it was evaluated.

This report shall not be reproduced, except in full, without the written approval of OMNI-Test Laboratories, Inc.



*Model: Explorer I  
Hearth & Home technologies  
1445 North Highway  
Colville, WA 99114*

## **Quality Assurance Plan**

[Redacted]

*Model: Explorer I  
Hearth & Home technologies  
1445 North Highway  
Colville, WA 99114*

# **Sample Analysis**

Analysis Worksheets  
Tared Filter, Probe, and O-Ring Data

OMNI-Test Laboratories, Inc. **ASTM E2780 Wood Heater Run Sheets**  
 Client: Hearth & Home Project Number: 061WS091E Run Number: 1  
 Model: Explorer I Tracking Number: 2135 Date: 9/28/15  
 Test Crew: B DAVIS  
 OMNI Equipment ID numbers: 00023, 00283A, 00291

ASTM E2515 Lab Sheet

Assembled By:  
B Davis

Date/Time in Dessicator:  
10/8/15 0810

Weighing #1	Weighing #2	Weighing #3	Weighing #4	Weighing #5
Date: <u>10/9/15</u>	Date: <u>10/12/15</u>	Date: <u>10/13/15</u>	Date:	Date:
Time: <u>0920</u>	Time: <u>1015</u>	Time: <u>0836</u>	Time:	Time:
R/H %: <u>29.3</u>	R/H %: <u>13.1</u>	R/H %: <u>9.0</u>	R/H %:	R/H %:
Temp: <u>75.3</u>	Temp: <u>73.2</u>	Temp: <u>72.1</u>	Temp:	Temp:
Audit: <u>99.9999</u>	Audit: <u>100.0000</u>	Audit: <u>99.9999</u>	Audit:	Audit:
Initials: <u>BA</u>	Initials: <u>BA</u>	Initials: <u>BA</u>	Initials:	Initials:

Train	Element	ID #	Tare (mg)	Weight (mg)	Weight (mg)	Weight (mg)	Weight (mg)	Weight (mg)
A (First Hour)	Front Filter	C108	124.0	126.8	126.6	126.5		
	Rear Filter	C109	123.3	123.1	123.9	123.0		
	Probe	4	114869.8	114870.7	114870.5	114870.4		
	O-Ring Set	R348	3474.9	3476.4	3475.5	3475.5		
A (Remainder)	Front Filter	C110	122.0	123.8	123.6	123.5		
	Rear Filter	C111	121.1	121.5	121.2	121.2		
	Probe	OES 4	114147.4	114148.0	114147.8	114147.6		
	O-Ring Set	R349	3245.9	3246.7	3246.0	3246.0		
B	Front Filter	C112	121.2	125.2	124.9	124.8		
	Rear Filter	C113	122.6	122.8	122.7	122.7		
	Probe	6	115359.1	115360.0	115359.8	115359.8		
	O-Ring Set	R359	3510.5	3511.4	3510.6	3510.6		
BG	Filter	C107	121.1	121.3	121.3			

Technician Signature: B Davis

Date: 10/13/15 23

ASTM E2780 Wood Heater Run Sheets

Client: Hearth & Home Project Number: 061WS091E Run Number: 2  
 Model: Explorer I Tracking Number: 2135 Date: 9/29/15  
 Test Crew: B Davis  
 OMNI Equipment ID numbers: 00023, 00283A, 00291

ASTM E2515 Lab Sheet

Assembled By:

B Davis

Date/Time in Dessicator:

10/8/15 0810

Weighing #1	Weighing #2	Weighing #3	Weighing #4	Weighing #5
Date: <u>10/9/15</u>	Date: <u>10/14/15</u>	Date: <u>10/13/15</u>	Date:	Date:
Time: <u>0920</u>	Time: <u>1015</u>	Time: <u>0836</u>	Time:	Time:
R/H %: <u>29.3</u>	R/H %: <u>15.1</u>	R/H %: <u>9.0</u>	R/H %:	R/H %:
Temp: <u>75.3</u>	Temp: <u>73.2</u>	Temp: <u>72.1</u>	Temp:	Temp:
Audit: <u>99.9999</u>	Audit: <u>100.0000</u>	Audit: <u>99.9999</u>	Audit:	Audit:
Initials: <u>DL</u>	Initials: <u>BL</u>	Initials: <u>JA</u>	Initials:	Initials:

Train	Element	ID #	Tare (mg)	Weight (mg)	Weight (mg)	Weight (mg)	Weight (mg)	Weight (mg)
A (First Hour)	Front Filter	<u>C115</u>	<u>120.6</u>	<u>123.4</u>	<u>123.3</u>	<u>123.3</u>		
	Rear Filter	<u>C116</u>	<u>122.1</u>	<u>122.3</u>	<u>122.3</u>	<u>122.3</u>		
	Probe	<u>8</u>	<u>115600.6</u>	<u>115601.2</u>	<u>115601.0</u>	<u>115601.1</u>		
	O-Ring Set	<u>R360</u>	<u>3309.3</u>	<u>3309.9</u>	<u>3309.2</u>	<u>3309.1</u>		
A (Remainder)	Front Filter	<u>C117</u>	<u>120.8</u>	<u>121.8</u>	<u>121.7</u>	<u>121.7</u>		
	Rear Filter	<u>C118</u>	<u>120.7</u>	<u>120.9</u>	<u>120.8</u>	<u>120.8</u>		
	Probe	<u>11</u>	<u>114196.3</u>	<u>114196.9</u>	<u>114196.7</u>	<u>114196.7</u>		
	O-Ring Set	<u>R361</u>	<u>4916.7</u>	<u>4917.7</u>	<u>4917.2</u>	<u>4917.1</u>		
B	Front Filter	<u>C119</u>	<u>122.0</u>	<u>125.2</u>	<u>125.1</u>	<u>125.1</u>		
	Rear Filter	<u>C120</u>	<u>121.2</u>	<u>121.6</u>	<u>121.5</u>	<u>121.5</u>		
	Probe	<u>13</u>	<u>114326.9</u>	<u>114327.5</u>	<u>114327.4</u>	<u>114327.2</u>		
	O-Ring Set	<u>R362</u>	<u>3379.8</u>	<u>3382.8</u>	<u>3381.5</u>	<u>3381.4</u>		
BG	Filter	<u>C114</u>	<u>121.7</u>	<u>121.8</u>	<u>121.9</u>			

Technician Signature: B Davis

Date: 10/13/15 24



ASTM E2780 Wood Heater Run Sheets

Client: Hearth & Home

Project Number: 061WS091E

Run Number: 3

Model: Explorer I

Tracking Number: 2135

Date: 9/30/15

Test Crew: B DAVID

OMNI Equipment ID numbers: 00013, 00203A, 00291

ASTM E2515 Lab Sheet

Assembled By:

B DAVID

Date/Time in Dessicator:

10/8/15 0810

Weighing #1	Weighing #2	Weighing #3	Weighing #4	Weighing #5
Date: <u>10/9/15</u>	Date: <u>10/13/15</u>	Date: <u>10/13/15</u>	Date:	Date:
Time: <u>0920</u>	Time: <u>1015</u>	Time: <u>0836</u>	Time:	Time:
R/H %: <u>29.3</u>	R/H %: <u>15.1</u>	R/H %: <u>9.0</u>	R/H %:	R/H %:
Temp: <u>75.3</u>	Temp: <u>73.2</u>	Temp: <u>72.1</u>	Temp:	Temp:
Audit: <u>99.9999</u>	Audit: <u>100.0000</u>	Audit: <u>99.9999</u>	Audit:	Audit:
Initials: <u>BA</u>	Initials: <u>BA</u>	Initials:	Initials:	Initials:

Train	Element	ID #	Tare (mg)	Weight (mg)	Weight (mg)	Weight (mg)	Weight (mg)	Weight (mg)
A (First Hour)	Front Filter	C122	121.2	125.5	125.3	125.2		
	Rear Filter	C123	112.6	112.5	112.4	112.3		
	Probe	16	114275.1	114276.2	114275.7	114275.5		
	O-Ring Set	R363	4059.8	4062.0	4061.4	4061.4		
A (Remainder)	Front Filter	C124	117.0	117.0	117.0	117.0		
	Rear Filter	C125	115.3	115.4	115.2	115.2		
	Probe	17	114569.6	114570.1	114569.8	114569.7		
	O-Ring Set	R364	3318.4	3320.3	3319.1	3319.1		
B	Front Filter	C126	121.7	126.2	126.1	125.9		
	Rear Filter	C127	121.3	121.1	120.9	120.9		
	Probe	20	114257.0	114257.8	114257.7	114257.5		
	O-Ring Set	R367	3367.0	3370.3	3369.0	3369.0		
BG	Filter	C121	121.3	121.5	121.5			

Technician Signature: [Signature]

Date: 10/13/15 25

**ASTM E2780 Wood Heater Run Sheets**

Client: Hearth & Home

Project Number: 061WS091E

Run Number: 4

Model: Explorer I

Tracking Number: 2135

Date: 9/30/15

Test Crew: B. Davis

OMNI Equipment ID numbers: 00023, 002534, 00291

**ASTM E2515 Lab Sheet**

Assembled By:

B. Davis

Date/Time in Dessicator:

10/8/15 0810

Weighing #1	Weighing #2	Weighing #3	Weighing #4	Weighing #5
Date: <u>10/9/15</u>	Date: <u>10/14/15</u>	Date: <u>10/15/15</u>	Date:	Date:
Time: <u>0920</u>	Time: <u>1015</u>	Time: <u>0836</u>	Time:	Time:
R/H %: <u>29.3</u>	R/H %: <u>15.1</u>	R/H %: <u>9.0</u>	R/H %:	R/H %:
Temp: <u>75.3</u>	Temp: <u>73.2</u>	Temp: <u>72.1</u>	Temp:	Temp:
Audit: <u>99.9999</u>	Audit: <u>100.0000</u>	Audit: <u>99.9999</u>	Audit:	Audit:
Initials: <u>BD</u>	Initials: <u>AL</u>	Initials: <u>AL</u>	Initials:	Initials:

Train	Element	ID #	Tare (mg)	Weight (mg)	Weight (mg)	Weight (mg)	Weight (mg)	Weight (mg)
A (First Hour)	Front Filter	C129	122.4	123.2	123.2	123.2		
	Rear Filter	C130	121.7	121.9	121.8	121.8		
	Probe	21	114397.2	114397.8	114397.6	114397.4		
	O-Ring Set	R368	3296.7	3298.2	3297.4	3297.4		
A (Remainder)	Front Filter	C131	121.4	125.7	125.8	125.6		
	Rear Filter	C132	120.8	121.2	121.0	121.1		
	Probe	22	114350.3	114351.4	114351.2	114351.1		
	O-Ring Set	R369	3287.3	3289.1	3288.3	3288.3		
B	Front Filter	C133	121.2	126.0	125.8	125.8		
	Rear Filter	C134	122.3	122.8	122.7	122.7		
	Probe	23	114079.8	114080.6	114080.4	114080.3		
	O-Ring Set	R370	3337.5	3339.6	3338.7	3338.8		
BG	Filter	C128	121.6	121.3	121.2			

Technician Signature: B. Davis

Date: 10/12/15

ASTM E2780 Wood Heater Run Sheets

Client: Hearth & Home

Project Number: 061WS091E

Run Number: 5

Model: Explorer I

Tracking Number: 2135

Date: 10/1/15

Test Crew: B Davis

OMNI Equipment ID numbers: 00223, 00283A, 00291

ASTM E2515 Lab Sheet

Assembled By:

B Davis

Date/Time in Dessicator:

10/8/15 0810

Weighing #1	Weighing #2	Weighing #3	Weighing #4	Weighing #5
Date: <u>10/9/15</u>	Date: <u>10/12/15</u>	Date: <u>10/13/15</u>	Date:	Date:
Time: <u>0920</u>	Time: <u>1015</u>	Time: <u>0836</u>	Time:	Time:
R/H %: <u>29.3</u>	R/H %: <u>15.1</u>	R/H %: <u>9.0</u>	R/H %:	R/H %:
Temp: <u>75.3</u>	Temp: <u>73.2</u>	Temp: <u>72.1</u>	Temp:	Temp:
Audit: <u>99.9999</u>	Audit: <u>100.0000</u>	Audit: <u>99.9999</u>	Audit:	Audit:
Initials: <u>BD</u>	Initials: <u>DL</u>	Initials: <u>BL</u>	Initials:	Initials:

Train	Element	ID #	Tare (mg)	Weight (mg)	Weight (mg)	Weight (mg)	Weight (mg)	Weight (mg)
A (First Hour)	Front Filter	<u>C135</u>	<u>121.5</u>	<u>125.7</u>	<u>125.4</u>	<u>125.3</u>		
	Rear Filter	<u>C136</u>	<u>124.1</u>	<u>124.6</u>	<u>124.6</u>	<u>124.5</u>		
	Probe	<u>27</u>	<u>114282.8</u>	<u>114283.6</u>	<u>114283.3</u>	<u>114283.2</u>		
	O-Ring Set	<u>R371</u>	<u>4140.0</u>	<u>4142.1</u>	<u>4141.3</u>	<u>4141.3</u>		
A (Remainder)	Front Filter	<u>C137</u>	<u>121.6</u>	<u>122.5</u>	<u>122.3</u>	<u>122.3</u>		
	Rear Filter	<u>C138</u>	<u>120.9</u>	<u>120.9</u>	<u>120.7</u>	<u>120.7</u>		
	Probe	<u>34</u>	<u>115871.4</u>	<u>115872.0</u>	<u>115871.7</u>	<u>115871.7</u>		
	O-Ring Set	<u>R372</u>	<u>3299.4</u>	<u>3301.3</u>	<u>3300.4</u>	<u>3300.4</u>		
B	Front Filter	<u>C139</u>	<u>124.7</u>	<u>129.8</u>	<u>129.6</u>	<u>129.5</u>		
	Rear Filter	<u>C140</u>	<u>121.6</u>	<u>122.2</u>	<u>122.0</u>	<u>122.0</u>		
	Probe	<u>59</u>	<u>122937.1</u>	<u>122938.1</u>	<u>122937.8</u>	<u>122937.7</u>		
	O-Ring Set	<u>R373</u>	<u>3333.4</u>	<u>3335.4</u>	<u>3334.4</u>	<u>3334.4</u>		
BG	Filter	<u>C141</u>	<u>121.3</u>	<u>121.1</u>	<u>121.2</u>			

Technician Signature: [Signature]

Date: 10/13/15

FILTER TARES

Date Placed in Desiccator: 9/3/15 Technician: A. Kovitz Balance ID # 23

Thermo/Hygro meter ID #: 291 Audit Weight ID # 131 (Balance audit mfr. Std.: 500 ± 0.72)

Filter Size/ID#	Date: 9/9/15 Time: 09:15 RH%: 37.1 T (F): 71.2 Initials: BK	Date: 9/10/15 Time: 0900 RH%: 7.1 T (F): 71.1 Initials: BK	Date: Time: RH%: T (F): Initials:	Manufacturer	Appliance	Project No.	Run No.
C107	1210	1211		Health Home	Exploer 1	00615091E	1
C108	1241	1240					
C109	1232	1233					
C110	1220	1220					
C111	1211	1211					
C112	1211	1212					
C113	1225	1226					
C114	1216	1217					
C115	1206	1206		Health Home	Exploer 1	00615091E	2
C116	1221	1221					
C117	1207	1208					
C118	1206 <del>1207</del> BK	1207					
C119	1218	1220					
C120	1212	1212					

Final Technician signature: BK Date: 9/10/15



FILTER TARES

Date Placed in Desiccator: 9/23/15 Technician: A. Kravitz Balance ID # 23

Thermo/Hygrometer ID #: 2A1 Audit Weight ID # 131 (Balance audit mfr. Std.: 500 ± 0.72)

Filter Size/ID#	Date: Time: RH%: T (F): Initials:	Date: Time: RH%: T (F): Initials:	Date: Time: RH%: T (F): Initials:	Manufacturer	Appliance	Project No.	Run No.
102 55	9/19/15 09:00 7.1 71.1 BD	9/19/15 09:00 7.1 71.1 BD	9/19/15 09:00 7.1 71.1 BD	Health n Home	Explosive F	006125091E	3
C121	1214	1213	1212				
C122	1213	1212	1211				
C123	1125	1126	1127				
C124	1170	1170	1170				
C125	1153	1153	1153				
C126	1217	1217	1217				
C127	1213	1213	1213				
C128	1216	1216	1216				
C129	1224	1224	1224				
C130	1218	1217	1217				
C131	1214	1214	1214				
C132	1208	1208	1208				
C133	1212	1212	1212				
C134	1223	1223	1223				
				Health n Home	Explosive I	006125091E	4

Final Technician signature: AD Date: 9/23/15

FILTER TARES

Date Placed in Desiccator: 9/21/15 0840 Technician: B Davis Balance ID # OMNI-0023

Thermo/Hygro meter ID #: OMNI-291 Audit Weight ID # OMNI-00131 (Balance audit mfr. Std.: 500 ± 0.72)

Filter Size/ID#	5000		5000		Date: Time: RH%: T (F): Initials:	Date: Time: RH%: T (F): Initials:	Manufacturer	Appliance	Project No.	Run No.
	Date: Time: RH%: T (F): Initials:	Date: Time: RH%: T (F): Initials:	Date: Time: RH%: T (F): Initials:	Date: Time: RH%: T (F): Initials:						
102 (47)	121.5	121.5	121.5	121.5			Head N Home PSCAD	Explorer I Paces	006165081E 0323U501N	5 31-58 9/29/15
110 55	124.0	124.1	124.1	124.1						
C135	121.5	121.5	121.5	121.5						
C136	124.0	124.1	124.1	124.1						
C137	121.5	121.6	121.6	121.6						
C138	120.8	120.9	120.9	120.9						
C139	124.7	124.7	124.7	124.7						
C140	121.5	121.6	121.6	121.6						
C141	121.2	121.3	121.3	121.3						
C142	124.6	124.7	124.7	124.7			PSCAD	Paces	0323U501N	30
C143	120.2	120.3	120.3	120.3						
C144	123.7	123.8	123.8	123.8						
C145	121.1	121.3	121.3	121.3						
C146	120.8	120.9	120.9	120.9						
C147	122.2	122.4	122.4	122.4						
C148	120.9	121.0	121.0	121.0						

Fetal Technician signature: B Davis Date: 9/22/15

TARE SHEET - PROBES

Date Placed in Dessicator: 9/14/15 0810

Thermohyrometer ID #: OMNI2-00291

Cleaned By: B. Davis

Balance ID #: OMNI-00023

Audit Weight ID #: OMNI-00283A 100g

Probe ID #	Date: 9/15/15 Time: 0815 RH %: 20.6 T (°F): 72.2 Audit: 99.9999	Date: 9/14/15 Time: 0815 RH %: 15.9 T (°F): 72.4 Audit: 99.9999	Date: Time: RH %: T (°F): Audit:	Date: Time: RH %: T (°F): Audit:	Date Used	Project Number	Run No.
4	114869.8	114869.8			9/24/15	0061WS091E	1
0654	114147.5	114147.4					
6	115359.1	115359.1					
8	115600.6	115600.6			9/24/15	0061WS091E	2
11	114196.5	114196.3					
13	114326.9	114326.9					
16	114275.0	114275.1			9/30/15	0061WS091E	3
17	114569.6	114569.6					
20	114256.9	114257.0					
21	114397.3	114397.2			9/30/15	0061WS091E	4
22	114350.3	114350.3					
23	114079.9	114079.8					
27	114282.8	114282.8			10/1/15	0061WS091E	5
34	115871.4	115871.4					
59	122937.0	122937.1					
	Initials: <u>BD</u>	Initials: <u>BD</u>	Initials:	Initials:			

Final Technician Signature: BD

Date: 9/14/15

# O-RING TARES

Balance ID # OMNI 00223

Technician: B. Davis

Date Placed in Desiccator: 9/15/15 0930

(Balance audit mfr. Std.: 500 ± 0.72)

Audit Weight ID # 283A 50g

Thermo/Hygro meter ID #: OMNI-00291

Addit wt O-Ring Size/ID# 47	50.0002		50.0005		Date: Time: RH%: T (F): Initials:	Manufacturer	Appliance	Project No.	Run No.
	Date: 9/18/15 Time: 0950 RH%: 17.4 T (F): 73.2 Initials: BA	Date: 9-17-15 Time: 0830 RH%: 15.5 T (F): 74.5 Initials: DR	Date: Time: RH%: T (F): Initials:	Date: Time: RH%: T (F): Initials:					
R340	3367.3	3367.3							
R341	3370.5	3370.5							
R342	3413.6	3413.6							
R341	4916.7	4916.7				Health n Home	Explosive I	006/USO91E	2
R342	3379.8	3379.8							
R343	4059.9	4059.8				Health n Home	Explosive I	006/USO91E	3
R344	3318.4	3318.4							
R347	3367.0	3367.0							
R348	3296.5	3296.7				Health n Home	Explosive I	006/USO91E	4
R349	3287.3	3287.3							
R370	3337.5	3337.5							
R371	4139.9	4140.0				Health n Home	Explosive I	006/USO91E	5
R372	3297.3	3297.4							
R373	3333.4	3333.4							

Date: 10/22/15

Final Technician signature: [Signature]



O-RING TARES

Date Placed in Desiccator: 9/15/15 0830 Technician: B. Davis Balance ID # OMM2-0023

Thermo/Hygro meter ID #: OMM2-00291 Audit Weight ID # 203A SD9 (Balance audit mfr. Std.: 500 ± 0.72)

O-Ring Size/ID#	Date: <u>50-0002</u> Time: <u>0950</u> RH%: <u>17.4</u> T (F): <u>73.2</u> Initials: <u>bn</u>	Date: <u>50-0005</u> Time: <u>0830</u> RH%: <u>15.5</u> T (F): <u>74.5</u> Initials: <u>bn</u>	Date: <u>50-0005</u> Time: <u>0820</u> RH%: <u>30.8</u> T (F): <u>73.4</u> Initials: <u>bn</u>	Manufacturer	Appliance	Project No.	Run No.
R346	4311.5	4311.4	-				
R347	3426.3	3425.3	3425.5				
R348	3475.1	3474.9	-	Heart w Home	Explorec I	006165091E	1
R349	3245.9	3245.9	-				
R350	3377.7	3376.8	3377.3				
R357	3612.7	3612.3	3612.8				
R358	3297.7	3297.0	3297.6				
R359	3510.7	3510.5	-	Heart w Home	Explorec I	006165091E	1
R360	3309.5	3309.1	3309.3	Heart w Home	Explorec I	006165091E	2
R374	3365.0	3364.9	-				
R375	3356.9	3356.9	-				
R376	3567.5	3567.5	-				
R377	3364.2	3364.1	-				
R378	3362.6	3362.0	3362.4				33

Final Technician signature: B. Davis Date: 10/23/15

# Calibrations

## Methods EPA 28R, ASTM E2 515, ASTM E2780

ID #	Lab Name/Purpose	Log Name	Attachment Type
1	Calibrator Dry Gas Meter	Rockwell Int'l Standard Test Meter	Calibration Certificate
428A	Dry Gas Meter	APEX XC-60A-ED	Calibration certificate
428B	Dry gas Meter	APEX XC-60A-ED	Calibration certificate
23	Scale-Analytical Balance	Mettler Analytical Balance	Calibration Certificate
131	500 mg Weight	Ohaus Weight Standard, 500 mg	Calibration Certificate
132	10 lb Weight	Weight Standard, 10 lb.	Calibration Certificate
5142132	Platform Scale	Panther Platform Scale	Calibration Certificate
NA	Barometer	Barometer – Princo	Manual Cover
296-T54	Tape Measure	Stanley Tape Measure	Calibration Log
186	Digital Pressure readout	Dwyer	Calibration Log
NA	Wood Moisture Meter	Moisture Meter - Delmhorst	See Test Run Notes
291	Thermohygrometer	Omega Digital Thermohygrometer	Calibration Log
NA	Combustion Gas Analyzer	Horiba	See Test Run Notes
432	Moisture Meter Calibrator	Delmhorst Moisture Content Calibrator	Calibration Log
417	Anemometer	Extech wind speed meter	Calibration certificate
NA	Calibration Gas	9.76% CO <sub>2</sub> , 0.993% CO	Calibration Certificate
NA	Calibration Gas	15.9% CO <sub>2</sub> , 4.06 % CO	Calibration Certificate
566	Stop Watch	Robic stop watch	Calibration Certificate
282	Dial Micrometer	Dial Caliper 0-6"	Calibration certificate
413	Dry Gas Meter	APEX Instruments	Calibration Certificate

## CERTIFICATE OF CALIBRATION

<b>CUSTOMER:</b>	OMNI TEST LABS INC. PORTLAND OR	<b>CALIBRATION DATE:</b>	10/23/14
<b>PO NUMBER:</b>	OTL-14-049	<b>CALIBRATION DUE:</b>	10/23/15
<b>INST. MANUFACTURER:</b>	ROCKWELL	<b>PROCEDURE:</b>	NAVAIR 17-20MG-02
<b>INST. DESCRIPTION:</b>	P.D. METER	<b>CALIBRATION FLUID:</b>	AIR @ 14.7 PSIA 70 F
<b>MODEL NUMBER:</b>	S-275	<b>STANDARD(S) USED:</b>	A4, A24, A321 DUE 02-2015
<b>SERIAL NUMBER:</b>	684390L	<b>NIST TRACE #' S:</b>	1329407628, 1361269184, 1390386562
<b>RATED UNCERTAINTY:</b>	+/- .5 % RD.	<b>AMBIENT CONDITIONS:</b>	760 mm HGA 51 % RH 72 F
<b>UNCERTAINTY GIVEN:</b>	FLOW measurement uncertainty: +/- .101 % RD. K=2	<b>CERTIFICATE FILE #:</b>	426663.14
<b>NOTES:</b>	AS RECEIVED/AS LEFT WITHIN SPECS. REFERENCE CONDITIONS ARE: 760 mm HGA 70 F **OMNI-00001**		

TEST POINT NUMBER	UUT INDICATED SCFM	DM.STD. ACTUAL SCFM	CORRECTION FACTOR	K FACTOR
1	0.2603	0.26	0.99888	60.067
2	0.5106	0.51	0.99877	60.074
3	1.0213	1.02	0.99868	60.079
4	1.4921	1.49	0.99858	60.085
5	2.0231	2.02	0.99845	60.093
6	2.4946	2.49	0.99817	60.110
7	3.0253	3.02	0.99823	60.106
8	3.4866	3.48	0.99812	60.113
<b>AVERAGE (Y)=</b>			<b>0.99848542</b>	

All instruments used in the performance of the shown calibration have traceability to the National Institute of Standards and Technology (NIST). The uncertainty ratio between the calibration standards (DM.STD.) used and the unit under test (UUT) is a minimum of 4:1, unless otherwise noted. Calibration has been performed per the shown procedure number, in accordance with ISO 10012:2003, ISO 17025:2005, ANSI/NCSSL-Z-540.3, and/or MIL-STD-45662A. Test methods: API2530-92 & ASME MFC-3M-1989.

**Dick Munns Company • 10572 Calle Lee #130 • Los Alamitos, CA 90720**  
Phone (714) 827-1215 • Fax (714) 827-0823

This Calibration Certificate shall not be reproduced, copied, in full or in part, without the approval of DICK MUNN'S COMPANY. The data shown applies only to the instrument being calibrated and under the stated conditions of calibration.

Date:

Approved By:

Calibration Technician:

10/23/2014

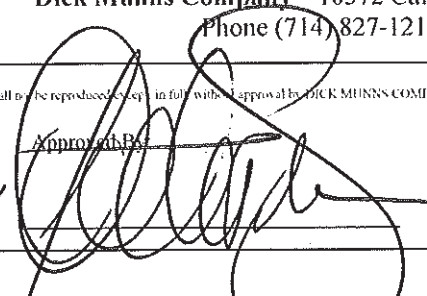

A

# Thermal Metering System Calibration

## Y Factor

Manufacturer: Apex  
 Model: XC-60A-ED-OMNI  
 Serial Number: 906014  
 OMNI Tracking No.: OMNI-00428A  
 Calibrated Orifice:  Yes

<b>Average Gas Meter y Factor</b>
<b>1.003</b>

<b>Orifice Meter dH@</b>
<b>N/A</b>

Calibration Date: 08/26/15  
 Calibrated by: B. Davis (Logger only)  
 Calibration Frequency: 6 Months  
 Next Calibration Due: 2/26/2016  
 Instrument Range: 1.000 cfm  
 Standard Temp.: 68 oF  
 Standard Press.: 29.92 "Hg  
 Barometric Press., Pb: 30.08 "Hg  
 Signature/Date: *B. Davis*

### Previous Calibration Comparison

Date	<u>7/3/2015</u>	Acceptable Deviation (5%)	Deviation
y Factor	<u>1.001</u>	<u>0.05005</u>	<u>0.002</u>
Acceptance	<b>Acceptable</b>		

### Current Calibration

Acceptable y Deviation	<u>0.020</u>
Maximum y Deviation	<u>0.006</u>
Acceptable dH@ Deviation	<u>N/A</u>
Maximum dH@ Deviation	<u>N/A</u>
Acceptance	<b>Acceptable</b>

### Reference Standard \*

Standard	Model	Standard Test Meter
Calibrator	S/N	<u>OMNI-00001</u>
	Calib. Date	<u>23-Oct-15</u>
	Calib. Value	<u>0.9985</u> y factor (ref)

Calibration Parameters	Run 1	Run 2	Run 3
Reference Meter Pressure ("H2O), Pr	<u>0.00</u>	<u>0.00</u>	<u>0.00</u>
DGM Pressure ("H2O), Pd	<u>3.70</u>	<u>2.30</u>	<u>0.70</u>
Initial Reference Meter	<u>184.6</u>	<u>192.607</u>	<u>198.2</u>
Final Reference Meter	<u>192.545</u>	<u>198.162</u>	<u>203.876</u>
Initial DGM	<u>0</u>	<u>0</u>	<u>0</u>
Final DGM	<u>7.817</u>	<u>5.513</u>	<u>5.677</u>
Temp. Ref. Meter (°F), Tr	<u>76.0</u>	<u>78.0</u>	<u>79.0</u>
Temperature DGM (°F), Td	<u>78.0</u>	<u>79.0</u>	<u>80.0</u>
Time (min)	<u>39.0</u>	<u>34.0</u>	<u>62.0</u>
Net Volume Ref. Meter, Vr	<u>7.945</u>	<u>5.555</u>	<u>5.676</u>
Net Volume DGM, Vd	<u>7.817</u>	<u>5.513</u>	<u>5.677</u>
<b>Gas Meter y Factor =</b>	<b><u>1.009</u></b>	<b><u>1.002</u></b>	<b><u>0.998</u></b>
<b>Gas Meter y Factor Deviation (from avg.)</b>	<u>0.006</u>	<u>0.001</u>	<u>0.005</u>
<b>Orifice dH@</b>	<u>N/A</u>	<u>N/A</u>	<u>N/A</u>
<b>Orifice dH@ Deviation (from avg.)</b>	<u>N/A</u>	<u>N/A</u>	<u>N/A</u>

where:

1. Deviation = |Average value for all runs - current run value|
- \*\* 2.  $y = [Vr \times (y \text{ factor (ref)}) \times (Pb + (Pr / 13.6)) \times (Td + 460)] / [Vd \times (Pb + (Pd / 13.6)) \times (Tr + 460)]$
- \*\* 3.  $dH@ = 0.0317 \times Pd / (Pb (Td + 460)) \times [(Tr + 460) \times \text{time}] / Vr^2$

\* Reference calibration is traceable to NIST through NIST Test # 40674, Kimble ASTM E1272, or NIST traceable laboratory

\*\* Equations come from EPA Method 5

The uncertainty of measurement is  $\pm 0.14 \text{ ft}^3/\text{min}$ . This is based on the reference standard having a TAR (Test Accuracy Ratio) of at least 4:1.



# Thermal Metering System Calibration

## Y Factor

Manufacturer: Apex  
 Model: XC-60A-ED-OMNI  
 Serial Number: 906014  
 OMNI Tracking No.: OMNI-00428B  
 Calibrated Orifice:  Yes

**Average Gas Meter y Factor**  
**0.988**

**Orifice Meter dH@**  
**N/A**

Calibration Date: 08/27/15  
 Calibrated by: B. Davis  
 Calibration Frequency: 6 Months (Logger only)  
 Next Calibration Due: 2/27/2016  
 Instrument Range: 1.000 cfm  
 Standard Temp.: 68 oF  
 Standard Press.: 29.92 "Hg  
 Barometric Press., Pb: 30.11 "Hg  
 Signature/Date: 

### Previous Calibration Comparison

Date	7/7/2015	Acceptable Deviation (5%)	Deviation
y Factor	0.996	0.0498	0.008
Acceptance	<b>Acceptable</b>		

### Current Calibration

Acceptable y Deviation	0.020
Maximum y Deviation	0.004
Acceptable dH@ Deviation	N/A
Maximum dH@ Deviation	N/A
Acceptance	<b>Acceptable</b>

Reference Standard *		
Standard	Model	Standard Test Meter
Calibrator	S/N	OMNI-00001
	Calib. Date	23-Oct-11
	Calib. Value	0.9985 y factor (ref)

Calibration Parameters	Run 1	Run 2	Run 3
Reference Meter Pressure ("H2O), Pr	0.00	0.00	0.00
DGM Pressure ("H2O), Pd	3.60	1.80	0.90
Initial Reference Meter	204.1	217.152	222.244
Final Reference Meter	210.909	222.202	229.607
Initial DGM	0	0	0
Final DGM	6.803	5.093	7.488
Temp. Ref. Meter (°F), Tr	80.0	81.0	84.0
Temperature DGM (°F), Td	80.0	83.0	86.0
Time (min)	35.0	39.0	87.0
Net Volume Ref. Meter, Vr	6.809	5.050	7.363
Net Volume DGM, Vd	6.803	5.093	7.488
<b>Gas Meter y Factor =</b>	<b>0.991</b>	<b>0.989</b>	<b>0.983</b>
<b>Gas Meter y Factor Deviation (from avg.)</b>	0.003	0.002	0.004
<b>Orifice dH@</b>	<b>N/A</b>	<b>N/A</b>	<b>N/A</b>
<b>Orifice dH@ Deviation (from avg.)</b>	N/A	N/A	N/A

where:

1. Deviation = |Average value for all runs - current run value|
- \*\* 2.  $y = [Vr \times (y \text{ factor (ref)}) \times (Pb + (Pr / 13.6)) \times (Td + 460)] / [Vd \times (Pb + (Pd / 13.6)) \times (Tr + 460)]$
- \*\* 3.  $dH@ = 0.0317 \times Pd / (Pb (Td + 460)) \times [(Tr + 460) \times \text{time}] / Vr^2$

\* Reference calibration is traceable to NIST through NIST Test # 40674, Kimble ASTM E1272, or NIST traceable laboratory

\*\* Equations come from EPA Method 5

The uncertainty of measurement is  $\pm 0.14 \text{ ft}^3/\text{min}$ . This is based on the reference standard having a TAR (Test Accuracy Ratio) of at least 4:1.

# Thermal Metering System Calibration Y Factor

Manufacturer: Apex  
 Model: XC-60A-ED-OMNI  
 Serial Number: 906014  
 OMNI Tracking No.: OMNI-00428B  
 Calibrated Orifice:  Yes

<b>Average Gas Meter y Factor</b>
<b>0.992</b>

<b>Orifice Meter dH@</b>
<b>N/A</b>

Calibration Date: 10/08/15  
 Calibrated by: B. Davis  
 Calibration Frequency: Explorer I Post test  
 Next Calibration Due: N/A  
 Instrument Range: 1.000 cfm  
 Standard Temp.: 68 oF  
 Standard Press.: 29.92 "Hg  
 Barometric Press., Pb: 30.12 "Hg  
 Signature/Date: *B. Davis*

### Previous Calibration Comparison

Date	<u>8/27/2015</u>	Acceptable Deviation (5%)	Deviation
y Factor	<u>0.988</u>	0.0494	0.004
Acceptance	<b>Acceptable</b>		

### Current Calibration

Acceptable y Deviation	0.020
Maximum y Deviation	0.000
Acceptable dH@ Deviation	N/A
Maximum dH@ Deviation	N/A
Acceptance	<b>Acceptable</b>

### Reference Standard \*

Standard	Model	Standard Test Meter
Calibrator	S/N	<u>OMNI-00001</u>
	Calib. Date	<u>23-Oct-15</u>
	Calib. Value	<u>0.9985</u> y factor (ref)

Calibration Parameters	Run 1	Run 2	Run 3
Reference Meter Pressure ("H2O), Pr	<u>0.00</u>	<u>0.00</u>	<u>0.00</u>
DGM Pressure ("H2O), Pd	<u>2.50</u>		
Initial Reference Meter	<u>495.637</u>		
Final Reference Meter	<u>500.718</u>		
Initial DGM	<u>0</u>		
Final DGM	<u>5.104</u>		
Temp. Ref. Meter (°F), Tr	<u>73.0</u>		
Temperature DGM (°F), Td	<u>75.0</u>		
Time (min)	<u>32.0</u>		
Net Volume Ref. Meter, Vr	5.081	0.000	0.000
Net Volume DGM, Vd	5.104	0	0
<b>Gas Meter y Factor =</b>	<b>0.992</b>	<b>#DIV/0!</b>	<b>#DIV/0!</b>
<b>Gas Meter y Factor Deviation (from avg.)</b>	0.000	#DIV/0!	#DIV/0!
<b>Orifice dH@</b>	<b>N/A</b>	<b>N/A</b>	<b>N/A</b>
<b>Orifice dH@ Deviation (from avg.)</b>	N/A	N/A	N/A

where:

1. Deviation = |Average value for all runs - current run value|
- \*\* 2.  $y = [Vr \times (y \text{ factor (ref)}) \times (Pb + (Pr / 13.6)) \times (Td + 460)] / [Vd \times (Pb + (Pd / 13.6)) \times (Tr + 460)]$
- \*\* 3.  $dH@ = 0.0317 \times Pd / (Pb (Td + 460)) \times [(Tr + 460) \times \text{time}] / Vr^2$

\* Reference calibration is traceable to NIST through NIST Test # 40674, Kimble ASTM E1272, or NIST traceable laboratory

\*\* Equations come from EPA Method 5

The uncertainty of measurement is  $\pm 0.14 \text{ ft}^3/\text{min}$ . This is based on the reference standard having a TAR (Test Accuracy Ratio) of at least 4:1.

# Thermal Metering System Calibration Y Factor

Manufacturer: Apex  
 Model: XC-60A-ED-OMNI  
 Serial Number: 906014  
 OMNI Tracking No.: OMNI-00428A  
 Calibrated Orifice:  Yes

<b>Average Gas Meter y Factor</b>
<b>0.993</b>

<b>Orifice Meter dH@</b>
<b>N/A</b>

Calibration Date: 10/08/15  
 Calibrated by: B. Davis  
 Calibration Frequency: Explorer I post test  
 Next Calibration Due: N/A  
 Instrument Range: 1.000 cfm  
 Standard Temp.: 68 oF  
 Standard Press.: 29.92 "Hg  
 Barometric Press., Pb: 30.12 "Hg  
 Signature/Date: *B. Davis*

### Previous Calibration Comparison

Date	<u>8/27/2015</u>	Acceptable Deviation (5%)	Deviation
y Factor	<u>1.003</u>	0.05015	0.010
Acceptance	<b>Acceptable</b>		

### Current Calibration

Acceptable y Deviation	0.020
Maximum y Deviation	0.001
Acceptable dH@ Deviation	N/A
Maximum dH@ Deviation	N/A
Acceptance	<b>Acceptable</b>

Reference Standard *		
Standard	Model	Standard Test Meter
Calibrator	S/N	<u>1</u>
	Calib. Date	<u>23-Oct-14</u>
	Calib. Value	<u>0.9985</u> y factor (ref)

Calibration Parameters	Run 1	Run 2	Run 3
Reference Meter Pressure ("H2O), Pr	<u>0.00</u>	<u>0.00</u>	<u>0.00</u>
DGM Pressure ("H2O), Pd	<u>2.10</u>	<u>2.10</u>	
Initial Reference Meter	<u>480.6</u>	<u>486.777</u>	
Final Reference Meter	<u>486.777</u>	<u>495.58</u>	
Initial DGM	<u>0</u>	<u>0</u>	
Final DGM	<u>6.209</u>	<u>8.859</u>	
Temp. Ref. Meter (°F), Tr	<u>71.0</u>	<u>72.0</u>	
Temperature DGM (°F), Td	<u>74.0</u>	<u>75.0</u>	
Time (min)	<u>40.0</u>	<u>57.0</u>	
Net Volume Ref. Meter, Vr	6.177	8.803	0.000
Net Volume DGM, Vd	6.209	8.859	0
<b>Gas Meter y Factor =</b>	<b>0.994</b>	<b>0.993</b>	<b>#DIV/0!</b>
<b>Gas Meter y Factor Deviation (from avg.)</b>	0.001	0.001	#DIV/0!
<b>Orifice dH@</b>	<b>N/A</b>	<b>N/A</b>	<b>N/A</b>
<b>Orifice dH@ Deviation (from avg.)</b>	N/A	N/A	N/A

where:

1. Deviation = |Average value for all runs - current run value|
- \*\* 2.  $y = [Vr \times (y \text{ factor (ref)}) \times (Pb + (Pr / 13.6)) \times (Td + 460)] / [Vd \times (Pb + (Pd / 13.6)) \times (Tr + 460)]$
- \*\* 3.  $dH@ = 0.0317 \times Pd / (Pb (Td + 460)) \times [(Tr + 460) \times \text{time}] / Vr^2$

\* Reference calibration is traceable to NIST through NIST Test # 40674, Kimble ASTM E1272, or NIST traceable laboratory

\*\* Equations come from EPA Method 5

The uncertainty of measurement is  $\pm 0.14 \text{ ft}^3/\text{min}$ . This is based on the reference standard having a TAR (Test Accuracy Ratio) of at least 4:1.

# Certificate of Calibration

Certificate Number: **598198**

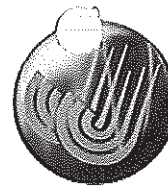

**JJ Calibrations, Inc.**  
 7007 SE Lake Rd  
 Portland, OR 97267-2105  
 Phone 503.786.3005  
 FAX 503.786.2994

**Omni-Test Laboratories**  
 13327 NE Airport Way  
 Portland, OR 97230

OnSite

PO: **OTL-15-020**  
 Order Date: **07/23/2015**  
 Authorized By: **N/A**



Property #: **OMNI-00023**  
 User: **N/A**  
 Department: **N/A**  
 Make: **Mettler**  
 Model: **AE200**  
 Serial #: **E17657**  
 Description: **Scale, 205g**  
 Procedure: **DCN 500818/500887**  
 Accuracy: **±0.0004g ±1 LSD**

Calibrated on: **07/23/2015**  
 \*Recommended Due: **01/23/2016**  
 Environment: **20 °C 40 % RH**  
 \* As Received: **Out of Tolerance**  
 \* As Returned: **Within Tolerance**  
 Action Taken: **Adjusted**  
 Technician: **111**

Remarks: \* Many factors may cause the unit to drift out of calibration before the recommended due date. Any reported error is the absolute value between the reference and the unit. Uncertainties include the effects of the unit.

## Standards Used

Std ID	Manufacturer	Model	Nomenclature	Due Date	Trace ID
723A	Rice Lake	1mg-200g (Class O)	Mass Set	10/31/2015	569749

Parameter	Measurement Data					UUT	Uncertainty	
	Measurement Description	Range	Unit	Reference	Min			Max
<b>Before</b>	<b>Force</b>			Reference	Min	Max	*Error	Accredited = ✓
		g	0.00100	0.0005	0.0015	0.0000	0.0010 g	5.7E-04 ✓
		g	0.01000	0.0095	0.0105	0.0000	0.0100 g	5.7E-04 ✓
		g	0.10000	0.0995	0.1005	0.0000	0.1000 g	5.7E-04 ✓
		g	0.50000	0.4995	0.5005	0.0000	0.5000 g	5.7E-04 ✓
		g	1.00000	0.9995	1.0005	0.0000	1.0000 g	5.7E-04 ✓
		g	40.00000	39.9995	40.0005	0.0004	40.0004 g	5.7E-04 ✓
		g	80.00000	79.9995	80.0005	0.0006	80.0006 g	5.7E-04 ✓
		g	120.00000	119.9995	120.0005	0.0009	120.0009 g	5.7E-04 ✓
		g	160.00000	159.9995	160.0005	0.0011	160.0011 g	5.8E-04 ✓
g	200.00000	199.9995	200.0005	0.0015	200.0015 g	5.7E-04 ✓		
<b>After</b>				Reference	Min	Max	*Error	Accredited = ✓
		g	0.00100	0.0005	0.0015	0.0002	0.0008 g	5.7E-04 ✓
		g	0.01000	0.0095	0.0105	0.0002	0.0098 g	5.7E-04 ✓
		g	0.10000	0.0995	0.1005	0.0002	0.0998 g	5.7E-04 ✓
		g	0.50000	0.4995	0.5005	0.0001	0.4999 g	5.7E-04 ✓
		g	1.00000	0.9995	1.0005	0.0001	0.9999 g	5.7E-04 ✓
		g	40.00000	39.9995	40.0005	0.0000	40.0000 g	5.7E-04 ✓
		g	80.00000	79.9995	80.0005	0.0000	80.0000 g	5.7E-04 ✓
		g	120.00000	119.9995	120.0005	0.0001	120.0001 g	5.7E-04 ✓
		g	160.00000	159.9995	160.0005	0.0000	160.0000 g	5.8E-04 ✓
g	200.00000	199.9995	200.0005	0.0000	200.0000 g	5.7E-04 ✓		

# Certificate of Calibration

Certificate Number: **547339**

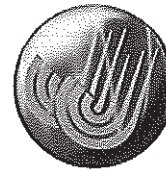

**JJ Calibrations, Inc.**

7007 SE Lake Rd  
Portland, OR 97267-2105  
Phone 503.786.3005  
FAX 503.786.2994

Omni-Test Laboratories  
13327 NE Airport Way  
Portland, OR 97230

PO: OTL-13-035  
Order Date: 11/19/2013  
Authorized By: N/A



Property #: **OMNI-00131**  
User: **N/A**  
Department: **N/A**  
Make: **Ohaus**  
Model: **500mg**  
Serial #: **27503**  
Description: **Mass**  
Procedure: **DCN 500901**  
Accuracy: **CLASS F ( $\pm 0.72\text{mg}$ )**

Calibrated on: **12/02/2013**  
\*Recommended Due: **12/02/2018**  
Environment: **20 °C 34 % RH**  
As Received: **Within Tolerance**  
As Returned: **Within Tolerance**  
Action Taken: **Calibrated**  
Technician: **34**

Remarks: \* Any number of factors may cause the calibration item to drift out of calibration before the recommended interval has expired  
**Refer to attachment for measurement results.**

## Standards Used

<u>Std ID</u>	<u>Manufacturer</u>	<u>Model</u>	<u>Nomenclature</u>	<u>Due Date</u>	<u>Trace ID</u>
432A	Sartorius	C-44	Microbalance 5.1g	03/11/2014	517747
723A	Rice Lake	1mg-200g (Class O)	Mass Set	09/05/2014	540048

JJ Calibrations, Inc. certifies that this instrument has been calibrated in accordance with the JJ Calibrations Quality Assurance Manual with the stated procedure using standards that are traceable to the National Institute of Standards and Technology (NIST), or other National Measurement Institutes (NMI's), or by using natural physical constants, intrinsic standards or ratio calibration techniques. The quality system and this certificate are in compliance with ANSI/NCSL Z540-1-1994, ISO/IEC 17025-2005, ISO 10012-1, the ISO 9000 family and QS 9000. The expanded uncertainties of measurements for this calibration are based upon 95% (2 sigma) confidence limits. Unless otherwise stated, a test accuracy ratio (TAR) of 4:1, if achievable, is maintained. The results reported herein apply only to the calibration of the item described above. This report may not be reproduced, except in full, without prior written consent of JJ Calibrations, Inc.

JJ Calibrations, Inc. quality system has been assessed and accredited to ISO/IEC 17025:2005.

\_\_\_\_\_  
Reviewer

3 Issued 12/06/2013 Rev # 14

\_\_\_\_\_  
Inspector

## SCALE WEIGHT CALIBRATION DATA SHEET

Weight to be calibrated: 10 lb

ID Number: 132

Standard Calibration Weight: 10 lb

ID Number: 256

Scale Used: MTW-150K

ID Number: 353

Date: 2/19/13

By: A. Kravitz

Standard Weight (A) (Lb.)	Weight Verified (B) (Lb.)	Difference (A - B)	% Error
10.0	10.0	0.0	Ø

\*Acceptable tolerance is 1%.

*This calibration is traceable to NIST using calibrated standard weights.*

Technician signature:  Date: 2/19/13



# SCALE CALIBRATION RECORD

Customer: HEARTH + HOME Date: 3/5/14  
 Work Order Number: 48312 PO Number: \_\_\_\_\_

Equipment Mfg.	Serial Number	Specifications	Weight used	Initial Readings	Final Readings
1. PANTHER	5142132	1000 X .1	Ø	Ø	Ø
	(Pass) Fail		50	49.9	50.0
Notes: <u>Calibrated</u>			100	99.9	100.0
			200	/	200.0
			300	/	300.0
			Ø	/	Ø
			Ø	/	Ø

Equipment Mfg.	Serial Number	Specifications	Weight used	Initial Readings	Final Readings
2. PANTHER	5208324	1000 X .1	Ø	Ø, Ø	/
	(Pass) Fail		50	(5.0).0	/
Notes: <u>PERIOD SHOWING AFTER EACH digit. CALLED METTLER - THEY STATED BAD MAIN BOARD DRIVER</u>			100	(1.0).0	/
			200	(2.0).0	/
			300	(3.0).0	/
			Ø	Ø, Ø	/
			Ø	Ø, Ø	/

Equipment Mfg.	Serial Number	Specifications	Weight used	Initial Readings	Final Readings
3. PANTHER	5237590	1000 X .1	Ø	Ø	/
	(Pass) Fail		50	50.0	/
Notes: _____			100	100.0	/
			200	200.0	/
			300	300.0	/
			Ø	Ø	/
			Ø	Ø	/

Equipment Mfg.	Serial Number	Specifications	Weight used	Initial Readings	Final Readings
4. PANTHER	5237589	1000 X .1	Ø	Ø	Ø
	(Pass) Fail		50	49.9	50.0
Notes: <u>Calibrated</u>			100	99.7	100.0
			200	/	200.0
			300	/	300.0
			Ø	/	Ø
			Ø	/	Ø

Additional Comments: \_\_\_\_\_

Last Checked: 9/13 Next Check Due: 9/14  
 Weights Certified: 10/12 Technician: JCC

# Instruction Booklet

for use with

# PRINCO

Fortin type mercurial

# Barometers

*Manufactured by*

PRINCO INSTRUMENTS, INC.  
1020 Industrial Blvd.  
Southampton, Pa. 18966-4095  
U.S.A.

Phone: 215 355-1500  
Fax: 215 355-7766



450  
National  
Weather  
Service  
Type



468  
NOVA  
Economy  
Model





## DIFFERENTIAL PRESSURE GAUGE CALIBRATION DATA SHEET 0-20" Digital Manometer

Range: 0-20" WC ID Number: OMNI-00186

Calibration Instrument: Digital Manometer ID Number: OMNI-00395

Date: 7/7/2015 By: J. Clark

This form is to be used only in conjunction with Standard Procedure C-SPC.

Range of Calibration Point ("WC)	Digital Manometer (A) ("WC)	Digital Manometer (B) ("WC)	Difference (A - B)	% Error of Full Span*
0.0 - 4.0	3.90	3.94	- 0.04	- 0.20 %
4.0 - 8.0	7.90	7.90	0.00	0.00 %
8.0 - 12.0	11.27	11.30	- 0.03	- 0.15 %
12.0 - 16.0	14.83	14.72	0.11	0.55 %
16.0 - 20.0	17.99	17.99	0.00	0.00 %

\*Acceptable tolerance is 4%.

The uncertainty of measurement is  $\pm 0.4$ " WC. This is based on the reference standard having a TAR (Test Accuracy Ratio) of at least 4:1.

Technician signature:  Date: 7/7/2015

Reviewed by:  Date: 7-10-15

# Certificate of Calibration

Certificate Number: **580819**

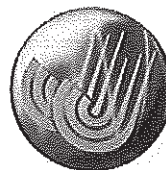

**JJ Calibrations, Inc.**  
 7007 SE Lake Rd  
 Portland, OR 97267-2105  
 Phone 503.786.3005  
 FAX 503.786.2994

**Omni-Test Laboratories**  
 13327 NE Airport Way  
 Portland, OR 97230

PO: **OTL-15-001**  
 Order Date: **01/09/2015**  
 Authorized By: **N/A**



Property #: **OMNI - 00291**  
 User: **N/A**  
 Department: **N/A**  
 Make: **Omega**  
 Model: **RH82**  
 Serial #: **9190156**  
 Description: **Thermohygrometer**  
 Procedure: **DCN 401013/403410**  
 Accuracy: **Refer to Mfg. Specs.**

Calibrated on: **01/20/2015**  
 \*Recommended Due: **01/20/2016**  
 Environment: **21 °C 40 % RH**  
 \* As Received: **Within Tolerance**  
 \* As Returned: **Within Tolerance**  
 Action Taken: **Calibrated**  
 Technician: **112**

Remarks: \* Many factors may cause the unit to drift out of calibration before the recommended due date. Any reported error is the absolute value between the reference and the unit. Uncertainties include the effects of the unit.

### Standards Used

Std ID	Manufacturer	Model	Nomenclature	Due Date	Trace ID
464A	General Eastern	M4-RH/D2	HUMIDITY STANDARD	12/14/2015	577811
497A	Hart Scientific	1502A	Precision Digital Thermometer	08/11/2015	568028
601A	Burns Engineering	200G05B085	INDUSTRIAL PRT	02/11/2016	554126

### Measurement Data

Parameter	Measurement Description	Range Unit	Reference	Min	Max	*Error	UUT	Uncertainty
<b>Before/After</b>	<b>Relative Humidity</b>	%	20.00	17.0	23.0	1.8	21.8 %	5.8E-01 ✓
			50.00	47.0	53.0	0.7	50.7 %	5.8E-01 ✓
			80.00	77.0	83.0	0.5	79.5 %	5.8E-01 ✓
<b>Temperature</b>		°C	5.40	4.4	6.4	0.2	5.2 °C	8.1E-02 ✓
			19.10	18.1	20.1	0.2	18.9 °C	8.1E-02 ✓

JJ Calibrations, Inc. certifies that this Instrument has been calibrated in accordance with the JJ Calibrations Quality Assurance Manual with the stated procedure using standards that are traceable to the National Institute of Standards and Technology (NIST), or other National Measurement Institutes (NMI's), or by using natural physical constants, intrinsic standards or ratio calibration techniques. The quality system and this certificate are in compliance with ANSI/NCCL Z540-1-1994, ISO/IEC 17025-2005, ISO 10012-1, the ISO 9000 family and QS 9000. The expanded uncertainties of measurements for this calibration are based upon 95% (2 sigma) confidence limits. Unless otherwise stated, a test accuracy ratio (TAR) of 4:1, if achievable, is maintained. The results reported herein apply only to the calibration of the item described above. This report may not be reproduced, except in full, without prior written consent of JJ Calibrations, Inc.  
 JJ Calibrations, Inc. quality system has been assessed and accredited to ISO/IEC 17025:2005.

*Lay Lamb*  
 Reviewer

3 Issued 01/21/2015 Rev # 15

*JM*  
 Inspector

## WOOD MOISTURE CONTENT CALIBRATION WORKSHEET

Moisture Content Standard OMNI ID #: 00432

Reference Moisture Content Standard: OMNI # 00430

Date	Temp.	Barometric Pressure	Fixed Moisture %	Fixed Moisture %	Observed Moisture %		Initials
6/11/10	70	30.44	22%	12%	22.0	12.0	JK
9/14/10	70	30.12	22%	12%	22.0	12.0	JK
2/14/11	70	29.7	22%	12%	23.8	12.3	JK
8/10/11	85	29.2	22%	12%	<del>22%</del> 12%	<del>22%</del> 12%	JK
11/29/11	66°	<del>34.0</del> 30.4	22%	12%	22.0	12.5	JK
9/19/2012	74	30.20	22%	12%	22.0 %	12.0 %	JK
12/31/2012	67 °F	30.25 in Hg	22%	12%	22.0 %	12.0 %	JK
3/28/2013	71 °F	30.10 in Hg	22%	12%	22.0 %	12.0 %	JK
6/28/2013	82 °F	30.14 in Hg	22%	12%	22.0 %	12.0 %	JK
9/19/2013	75 °F	29.95 in Hg	22%	12%	22.0 %	12.0 %	JK
12/17/2013	70 °F	30.29 in Hg	22%	12%	22.0 %	12.0 %	JK
2/13/2014	65.0 °F	30.23 in Hg	22%	12%	22.0 %	12.0 %	JK
7/2/2014	77.5 °F	30.04 in Hg	22%	12%	22.0 %	12.0 %	JK
10/2/2014	66.0 °F	30.08 in Hg	22%	12%	22.0 %	12.0 %	JK
12/31/2014	71 °F	30.56 in Hg	22%	12%	22.0 %	12.0 %	JK
4/3/2015	72 °F	30.30 in Hg	22%	12%	22.0 %	12.0 %	JK
6/29/2015	79 °F	30.10 in Hg	22%	12%	22.0 %	12.0 %	JK
			22%	12%			

Notes: \_\_\_\_\_  
 \_\_\_\_\_  
 \_\_\_\_\_

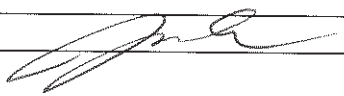
Technician signature:  Date: 12/31/2012

# Certificate of Calibration

Certificate Number: **597294**

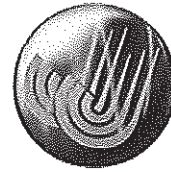

**JJ Calibrations, Inc.**  
 7007 SE Lake Rd  
 Portland, OR 97267-2105  
 Phone 503.786.3005  
 FAX 503.786.2994

**Omni-Test Laboratories**  
 13327 NE Airport Way  
 Portland, OR 97230

PO: **OTL-15-025**  
 Order Date: **07/10/2015**  
 Authorized By: **N/A**

Property #: **OMNI-00417**  
 User: **N/A**  
 Department: **N/A**  
 Make: **Extech**  
 Model: **451126**  
 Serial #: **08120397**  
 Description: **Anemometer**  
 Procedure: **DCN 404947/400331**  
 Accuracy: **±3%FS + 20 ft/min**

Calibrated on: **07/15/2015**  
 \*Recommended Due: **07/15/2016**  
 Environment: **20 °C 56 % RH**  
 As Received: **Within Tolerance**  
 As Returned: **Within Tolerance**  
 Action Taken: **Calibrated**  
 Technician: **118**

Remarks: \* Many factors may cause the unit to drift out of calibration before the recommended due date. Any reported error is the absolute value between the reference and the unit.

Received/returned with case.

### Standards Used

Std ID	Manufacturer	Model	Nomenclature	Due Date	Trace ID
568	TSI	8705	DP-CALC	09/24/2015	569813
497A	Hart Scientific	1502A	Precision Digital Thermometer	08/11/2015	568028
672A	Hart Scientific	5618B	PRT Probe	03/26/2016	585560

### Measurement Data

Parameter	Measurement Description	Range Unit	Reference	Min	Max	*Error	UUT
<b>Before/After</b>	<b>Air Velocity</b>	FPM	765.00	481.0	1049.0	261.1	503.9 FPM
		FPM	1135.00	851.0	1419.0	260.8	874.2 FPM
		FPM	1920.0	1636	2204	267	1653 FPM
<b>Temperature / Ambient</b>		°F	72.770	68.86	72.86	0.03	72.80 °F

JJ Calibrations, Inc. certifies that this instrument has been calibrated in accordance with the JJ Calibrations Quality Assurance Manual with the stated procedure using standards that are traceable to the National Institute of Standards and Technology (NIST), or other National Measurement Institutes (NMI's), or by using natural physical constants, intrinsic standards or ratio calibration techniques. The quality system and this certificate are in compliance with ANSI/NCSL Z540-1-1994, ISO/IEC 17025-2005, ISO 10012-1, the ISO 9000 family and QS 9000. The expanded uncertainties of measurements for this calibration are based upon 95% (2 sigma) confidence limits. Unless otherwise stated, a test accuracy ratio (TAR) of 4:1, if achievable, is maintained. The results reported herein apply only to the calibration of the item described above. This report may not be reproduced, except in full, without prior written consent of JJ Calibrations, Inc.  
 JJ Calibrations, Inc. quality system has been assessed and accredited to ISO/IEC 17025:2005.

  
 Reviewer

Issued 07/15/2015 Rev # 15

  
 Inspector



The Gas Professionals™

Certificate of Analysis - EPA Protocol Mixture

QUARG INC  
SX-38640  
2004 psig  
4/11/2011  
4/5/2014

Protocol: Reference #  
G1/G2 559152

DO NOT USE THIS CYLINDER  
PRESSURE FALLS BELOW

REPLICATE RESPONSES  
Date: 3/29/2011  
4.06%  
4.07%  
4.05%

Component: Carbon Monoxide  
Certified Conc: 4.06% ± 2% REL

Date: 4/11/2011  
15.9%  
15.9%  
15.9%

Component: Carbon Dioxide  
Certified Conc: 15.9% ± 1% REL

Nitrogen

COMPONENT STANDARDS

Component: Carbon Monoxide  
SRM # SRM-2637a  
Sample # 56-E-53

Component: Carbon Dioxide  
SRM-2745





**LIQUID TECHNOLOGY CORPORATION**  
 "INDUSTRY LEADER IN SPECIALTY GASES"

Certificate of Analysis  
**- EPA PROTOCOL GAS -**

Customer OXARC, Inc (Pasco, WA)  
Date April 22, 2013  
Delivery Receipt DR-46619  
Gas Standard 1.00% CO, 10.0% Carbon Dioxide/Nitrogen - EPA PROTOCOL  
Final Analysis Date April 22, 2013  
Expiration Date April 22, 2021

Component Carbon Monoxide, Carbon Dioxide  
Balance Gas Nitrogen

**DO NOT USE BELOW 100 psig**

Analytical Data:  
 EPA Protocol, Section No. 2.2, Procedure G-1

**Reported Concentrations**  
**Carbon Monoxide: 0.993% +/- 0.006%**  
**Carbon Dioxide: 9.76% +/- 0.07%**  
**Nitrogen: Balance**

<u>Reference Standards:</u>		
SRM/GMIS:	GMIS/GMIS	GMIS/GMIS
Cylinder Number:	EB-0015842/EB-0014708	EB-0015844/CC-185129
Concentration:	4969 ppm CO/10,001 ppm CO	6.847% CO2/13.92% CO2
Expiration Date:	12/02/14 - 01/07/15	10/03/20 - 06/24/13

<u>Certification Instrumentation</u>		
Component:	Carbon Monoxide	Carbon Dioxide
Make/Model:	Horiba VIA-510	Horiba VIA-510
Serial Number:	4344482008	SN075GSF
Principal of Measurement:	NDIR	NDIR
Last Calibration:	April 18, 2013	April 03, 2013

<u>Cylinder Data</u>		
Cylinder Serial Number:	CC-79641	Cylinder Outlet: CGA 350
Cylinder Volume:	119 Cubic Feet	Cylinder Pressure: 1700 psig, 70°F

Analytical Uncertainty and NIST Traceability are in compliance with EPA-600/R-12/531.

Certified by:   
 David Scott

PGVP Vendor ID: E12013

**"UNMATCHED EXCELLENCE"**  
 2048 APEX COURT APOPKA, FLORIDA 32703 - PHONE (407)-292-2990 FAX (407)-292-3313  
 WWW.LIQUIDTECHCORP.COM  
 APOPKA, FL • HOUSTON, TX

## NIST Stopwatch Calibration, Time Proficiency Testing Procedure and Data Sheet

Date: 8/7/15 User/Technician: J. Kafel  Pass  Fail

NIST traceable stopwatch OMNI tracking number: 565 Last Cal: 7/30/15

Stopwatch to be tested for time proficiency OMNI tracking number: OMNI-00566

1. Start the NIST traceable stopwatch: at a predetermined time (i.e. 1.00 minutes), the technician shall start the watch being tested. When 15.00 seconds have passed (i.e. the NIST traceable stopwatch reads 1 minute, 15 seconds), the technician shall stop the watch being tested. Record the target time interval (i.e. 15.00 seconds). Repeat this step twice and record the data.
2. Repeat step #1 for each of the following target time intervals: 30.00 seconds, 10.00 minutes, and 30 minutes.
3. If the delta between the target time and measured time is less than 5% of the target time interval or 2.00 seconds (whichever is less), then the technician has demonstrated proficiency with the specific instrument utilized in the proficiency test. The proficiency is valid for a period of 12 months.
4. Archive the proficiency test data and information, including the effective date and expiration date of the proficiency, in the equipment record for the instrument involved.

Target time: <u>15.00 seconds</u>	#1 Measured time: <u>14.93</u>	#2 Measured time: <u>15.07</u>	#3 Measured time: <u>15.05</u>
Target time: <u>30.00 seconds</u>	#1 Measured time: <u>29.84</u>	#2 Measured time: <u>29.91</u>	#3 Measured time: <u>30.11</u>
Target time: <u>45.00 seconds</u>	#1 Measured time: <u>44.82</u>	#2 Measured time: <u>45.30</u>	#3 Measured time: <u>46.33</u>
Target time: <u>60.00 seconds</u>	#1 Measured time: <u>59.90</u>	#2 Measured time: <u>1:00.29</u>	#3 Measured time: <u>1:00.13</u>
Target time: <u>10.00 minutes</u>	#1 Measured time: <u>10:00:16</u>	#2 Measured time: <u>9:59.94</u>	#3 Measured time: <u>10:00:08</u>
Target time: <u>30.00 minutes</u>	#1 Measured time: <u>30:00:07</u>	#2 Measured time: <u>30:00:11</u>	#3 Measured time: <u>30:00:28</u>

The uncertainty of measurement is  $\pm 1$  sec. This is based on the reference standard having a TAR (Test Accuracy Ratio) of at least 4:1.

This calibration procedure is confirmed by the manufacturer as a proper method for evaluating the accuracy of timers.

Technician Signature: J. Kafel Date: 8/7/15

Reviewed by: B. Smith Date: 9/9/15



# Thermal Metering System Calibration Y Factor

Manufacturer: Apex Instruments  
 Model: DGM-SK25DA-TL  
 Serial Number: 8004298  
 OMNI Tracking No.: OMNI-00413  
 Calibrated Orifice:  Yes

<b>Average Gas Meter y Factor</b>
<b>0.996</b>

<b>Orifice Meter dH@</b>
<b>N/A</b>

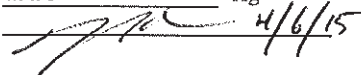
Calibration Date: 04/06/15  
 Calibrated by: J. Clark  
 Calibration Frequency: 6 months  
 Next Calibration Due: 10/6/2015  
 Instrument Range: 1.000 cfm  
 Standard Temp.: 68 °F  
 Standard Press.: 29.92 "Hg  
 Barometric Press., Pb: 29.93 "Hg  
 Signature/Date:  4/6/15

### Previous Calibration Comparison

Date	9/23/2014	Acceptable Deviation (5%)	Deviation
y Factor	0.989194538	0.049459727	0.007
Acceptance	Acceptable		

### Current Calibration

Acceptable y Deviation	0.020
Maximum y Deviation	0.003
Acceptable dH@ Deviation	N/A
Maximum dH@ Deviation	N/A
Acceptance	Acceptable

### Reference Standard \*

Standard Calibrator	Model	Standard Test Meter
	S/N	OMNI-00001
	Calib. Date	23-Oct-15
	Calib. Value	0.9985 y factor (ref)

Calibration Parameters	Run 1	Run 2	Run 3
Reference Meter Pressure ("H2O), Pr	0.00	0.00	0.00
DGM Pressure ("H2O), Pd	1.85	0.59	1.09
Initial Reference Meter	818.187	826.09	834.722
Final Reference Meter	826.019	834.676	844.731
Initial DGM	0	0	0
Final DGM	7.841	8.576	10.013
Temp. Ref. Meter (°F), Tr	66.5	68.5	68.4
Temperature DGM (°F), Td	66.7	69.1	68.8
Time (min)	37.0	67.0	60.0
Net Volume Ref. Meter, Vr	7.832	8.586	10.009
Net Volume DGM, Vd	7.841	8.576	10.013
Gas Meter y Factor =	0.993	0.999	0.996
Gas Meter y Factor Deviation (from avg.)	0.003	0.003	0.000
Orifice dH@	N/A	N/A	N/A
Orifice dH@ Deviation (from avg.)	N/A	N/A	N/A

where:

1. Deviation = |Average value for all runs - current run value|
- \*\* 2.  $y = [Vr \times (y \text{ factor (ref)}) \times (Pb + (Pr / 13.6)) \times (Td + 460)] / [Vd \times (Pb + (Pd / 13.6)) \times (Tr + 460)]$
- \*\* 3.  $dH@ = 0.0317 \times Pd / (Pb (Td + 460)) \times [(Tr + 460) \times \text{time}] / Vr^2$

\* Reference calibration is traceable to NIST through NIST Test # 40674, Kimble ASTM E1272, or NIST traceable laboratory

\*\* Equations come from EPA Method 5

The uncertainty of measurement is ±0.14 ft<sup>3</sup>/min. This is based on the reference standard having a TAR (Test Accuracy Ratio) of at least 4:1.

*Model: Explorer I  
Hearth & Home technologies  
1445 North Highway  
Colville, WA 99114*

## **Example Calculations**

## Equations and Sample Calculations – ASTM E2779 & E2515

Manufacturer: Hearth & Home  
Model: Explorer I  
Run: 1  
Category:

Equations used to calculate the parameters listed below are described in this appendix. Sample calculations are provided for each equation. The raw data and printout results from a sample run are also provided for comparison to the sample calculations.

$M_{Sdb}$  – Weight of test fuel spacers, dry basis, kg

$M_{Cdb}$  – Weight of test fuel crib, excluding nails and spacers, dry basis, kg

$D_{Cdb}$  - Density of fuel crib, excluding spacers and nails, dry basis, lbs/ft<sup>3</sup>

$M_{FTAdb}$  - Total weight of fuel crib excluding nails, dry basis, kg

BR – Dry burn rate, kg/hr

$V_s$  – Average gas velocity in the dilution tunnel, ft/sec

$Q_{sd}$  – Average gas flow rate in dilution tunnel, dscf/hr

$V_{m(std)}$  – Volume of gas sampled, corrected to dry standard conditions, dscf

$m_n$  – Total particulate matter collected, mg

$C_s$  - Concentration of particulate matter in tunnel gas, dry basis, corrected to standard conditions, g/dscf

$E_T$  – Total particulate emissions, g

PR - Proportional rate variation

$PM_R$  – Particulate emissions for test run, g/hr

$PM_F$  – Particulate emission factor for test run, g/dry kg of fuel burned

**M<sub>Sdb</sub> – Weight of test fuel spacers, dry basis, kg**

ASTM E2780 equation (1)

$$M_{Sdb} = (M_{Swb}) (100 / (100 + FM_S))$$

Where,

FM<sub>S</sub> = average fuel moisture of test fuel spacers, % dry basis

M<sub>Swb</sub> = weight of test fuel spacers, wet basis, kg

Sample Calculation:

$$FM_S = 7.7 \%$$

$$M_{Swb} = 1.5 \text{ lbs}$$

0.4536 = Conversion factor from lbs to kg

$$M_{Sdb} = [(1.5 \times 0.4536) (100 / (100 + 7.7))]$$

$$M_{Sdb} = 0.6 \text{ kg}$$

**$M_{Cdb}$** – Weight of test fuel crib, excluding nails and spacers, dry basis, kg  
ASTM E2780 equation (2)

$$M_{Cdb} = \Sigma[(M_{CPnwb})(100/(100 + FM_{CPn}))]$$

Where,

$M_{CPnwb}$  = weight of each test fuel piece n in fuel crib, excluding nails and spacers, wet basis, kg

$FM_{CPn}$  = Average fuel moisture of test fuel n in fuel crib, % dry basis

Sample Calculation (test fuel piece 1):

$$M_{CPnwb} = 1.3$$

$$FM_{CPn} = 19.8$$

$$= 1.3 (100/(100+ 19.8 )$$

$$= 1.1 \text{ lbs}$$

Total crib weight, excluding spacer 8.41 lbs

$$M_{Cdb} = \mathbf{3.81 \text{ kg}}$$

**$D_{Cdb}$**  - Density of fuel crib, excluding spacers and nails, dry basis, lbs/ft<sup>3</sup>  
ASTM E2780 equation (3)

$$D_{Cdb} = M_{Cdb}/V_C$$

Where,

$$V_C = \text{Volume of fuel crib, ft}^3$$

Sample calculation:

$$V_C = 523 \text{ in}^3$$

$$1728 = \text{conversion from in}^3 \text{ to ft}^3$$

$$D_{Cdb} = 8.41 / 523 * ###$$

$$= \mathbf{27.8} \text{ lbs/ft}^3$$



**$M_{FTAdb}$**  - Total weight of fuel crib excluding nails, dry basis, kg  
ASTM E2780 equation (4)

$$M_{FTAdb} = M_{Sdb} + M_{Cdb}$$

Sample calculation:

$$M_{FTAdb} = 0.63 + 3.81$$

$$= \mathbf{4.45 \text{ kg}}$$

**BR – dry burn rate, kg/hr**

ASTM E2780 equation (5)

$$BR = \frac{60 M_{FTAdb}}{\theta}$$

Where,

$\theta$  = Total length of test run, min

Sample Calculation:

$$M_{Bdb} = 4.45 \quad \text{kg}$$

$$\theta = 310 \quad \text{min}$$

$$BR = \frac{60 \times 4.45}{310}$$

$$BR = \mathbf{0.86} \quad \text{kg/hr}$$

**V<sub>s</sub> – Average gas velocity in the dilution tunnel, ft/sec**

ASTM E2515 equations (9)

$$V_s = F_p \times k_p \times C_p \times (\sqrt{\Delta P})_{avg} \times \sqrt{\frac{T_{s(avg)}}{P_s \times M_s}}$$

Where:

- F<sub>p</sub> = Adjustment factor for center of tunnel pitot tube placement,  $F_p = \frac{V_{strav}}{V_{scent}}$ , ASTM E2515 Equation (1)
- V<sub>scent</sub> = Dilution tunnel velocity calculated after the multi-point pitot traverse at the center, ft/sec
- V<sub>strav</sub> = Dilution tunnel velocity calculated after the multi-point pitot traverse, ft/sec
- k<sub>p</sub> = Pitot tube constant, 85.49
- C<sub>p</sub> = Pitot tube coefficient: 0.99, unitless
- ΔP\* = Velocity pressure in the dilution tunnel, in H<sub>2</sub>O
- T<sub>s</sub> = Absolute average gas temperature in the dilution tunnel, °R; (°R = °F + 460)
- P<sub>s</sub> = Absolute average gas static pressure in dilution tunnel, = P<sub>bar</sub> + P<sub>g</sub>, in Hg
- P<sub>bar</sub> = Barometric pressure at test site, in. Hg
- P<sub>g</sub> = Static pressure of tunnel, in. H<sub>2</sub>O; (in Hg = in H<sub>2</sub>O/13.6)
- M<sub>s</sub> = \*\*The dilution tunnel wet molecular weight; M<sub>s</sub> = 28.78 assuming a dry weight of 29 lb/lb-mole

Sample calculation:

$$F_p = \frac{17.04}{19.40} = 0.878$$

$$V_s = 0.878 \times 85.49 \times 0.99 \times 0.283 \times \left( \frac{85.2 + 460}{\left( \frac{28.56 + \frac{-0.49}{13.6}}{28.78} \right)^{1/2}} \right)$$

$$V_s = 17.14 \text{ ft/s}$$

\*The ASTM test standard mistakenly has the square root of the average delta p instead of the average of the square root of delta p. The current EPA Method 2 is also incorrect. This was verified by Mike Toney at EPA.

\*\*The ASTM test standard mistakenly identifies M<sub>s</sub> as the dry molecular weight. It should be the wet molecular weight as indicated in EPA Method 2.

**Q<sub>sd</sub> – Average gas flow rate in dilution tunnel, dscf/hr**

ASTM E2515 equation (3)

$$Q_{sd} = 3600 \times (1 - B_{ws}) \times v_s \times A \times \frac{T_{std}}{T_{s(avg)}} \times \frac{P_s}{P_{std}}$$

Where:

- 3600 = Conversion from seconds to hours (ASTM method uses 60 to convert in minutes)
- B<sub>ws</sub> = Water vapor in gas stream, proportion by volume; assume 2%
- A = Cross sectional area of dilution tunnel, ft<sup>2</sup>
- T<sub>std</sub> = Standard absolute temperature, 528 °R
- P<sub>s</sub> = Absolute average gas static pressure in dilution tunnel, = P<sub>bar</sub> + P<sub>g</sub>, in Hg
- T<sub>s(avg)</sub> = Absolute average gas temperature in the dilution tunnel, °R; (°R = °F + 460)
- P<sub>std</sub> = Standard absolute pressure, 29.92 in Hg

Sample calculation:

$$Q_{sd} = 3600 \times (1 - 0.02) \times 17.14 \times 0.196 \times \frac{528}{85.2 + 460} \times \frac{28.6 + \frac{-0.49}{13.6}}{29.92}$$

Q<sub>sd</sub> = ##### dscf/hr

$V_{m(std)}$  – Volume of Gas Sampled Corrected to Dry Standard Conditions, dscf  
 ASTM E2515 equation (6)

$$V_{m(std)} = K_1 V_m Y \frac{P_{bar} + \left( \frac{\Delta H}{13.6} \right)}{T_m}$$

Where:

- $K_1$  = 17.64 °R/in. Hg
- $V_m$  = Volume of gas sample measured at the dry gas meter, dcf
- $Y$  = Dry gas meter calibration factor, dimensionless
- $P_{bar}$  = Barometric pressure at the testing site, in. Hg
- $\Delta H$  = Average pressure differential across the orifice meter, in. H<sub>2</sub>O
- $T_m$  = Absolute average dry gas meter temperature, °R

Sample Calculation:

Using equation for Train 1:

$$V_{m(std)} = 17.64 \times 49.728 \times 1.003 \times \frac{\left( 28.56 + \frac{1.99}{13.6} \right)}{\left( 82.3 + 460 \right)}$$

$$V_{m(std)} = \mathbf{46.575} \text{ dscf}$$

Using equation for Train 2:

$$V_{m(std)} = 17.64 \times 51.673 \times 0.988 \times \frac{\left( 28.56 + \frac{2.54}{13.6} \right)}{\left( 83.7 + 460 \right)}$$

$$V_{m(std)} = \mathbf{47.619} \text{ dscf}$$

Using equation for ambient train:

$$V_{m(std)} = 17.64 \times 80.39 \times 0.996 \times \frac{\left( 28.56 + \frac{0.00}{13.6} \right)}{\left( 79.9 + 460 \right)}$$

$$V_{m(std)} = \mathbf{74.706} \text{ dscf}$$

**$m_n$  – Total Particulate Matter Collected, mg**

ASTM E2515 Equation (12)

$$m_n = m_p + m_f + m_g$$

Where:

$m_p$  = mass of particulate matter from probe, mg

$m_f$  = mass of particulate matter from filters, mg

$m_g$  = mass of particulate matter from filter seals, mg

Sample Calculation:

Using equation for Train 1 (first hour):

$$m_n = 0.6 + 2.8 + 0.0$$

$$m_n = 3.4 \text{ mg}$$

Using equation for Train 1 (post-first hour):

$$m_n = 0.1 + 1.6 + 0.0$$

$$m_n = 1.7 \text{ mg}$$

Train 1 aggregate:

$$m_n = 3.4 + 1.7$$

$$m_n = 5.1 \text{ mg}$$

Using equation for Train 2:

$$m_n = 0.1 + 3.7 + 0.7$$

$$m_n = 4.5 \text{ mg}$$



**C<sub>s</sub> - Concentration of particulate matter in tunnel gas, dry basis, corrected to standard conditions, g/dsc**  
ASTM E2515 equation (13)

$$C_s = K_2 \times \frac{m_n}{V_{m(std)}}$$

Where:

K<sub>2</sub> = Constant, 0.001 g/mg

m<sub>n</sub> = Total mass of particulate matter collected in the sampling train, mg

V<sub>m(std)</sub> = Volume of gas sampled corrected to dry standard conditions, dscf

Sample calculation:

For Train 1:

$$C_s = 0.001 \times \frac{5.1}{46.58}$$

$$C_s = \mathbf{0.00011} \text{ g/dscf}$$

For Train 2

$$C_s = 0.001 \times \frac{4.5}{47.62}$$

$$C_s = \mathbf{0.00009} \text{ g/dscf}$$

For Ambient Train

$$C_r = 0.001 \times \frac{0.2}{74.71}$$

$$C_r = \mathbf{0.000003} \text{ g/dscf}$$

**E<sub>T</sub> – Total Particulate Emissions, g**

ASTM E2515 equation (15)

$$E_T = (C_s - C_r) \times Q_{std} \times \theta$$

Where:

- C<sub>s</sub> = Concentration of particulate matter in tunnel gas, g/dscf
- C<sub>r</sub> = Concentration particulate matter room air, g/dscf
- Q<sub>std</sub> = Average dilution tunnel gas flow rate, dscf/hr
- θ = Total time of test run, minutes

Sample calculation:

For Train 1

$$E_T = ( 0.000109 - 0.000003 ) \times \text{#####} \times \frac{310}{60}$$
$$E_T = \underline{6.05} \text{ g}$$

For Train 2

$$E_T = ( 0.000094 - 0.000003 ) \times \text{#####} \times \frac{310}{60}$$
$$E_T = \underline{5.20} \text{ g}$$

Average

$$E = \underline{5.62} \text{ g}$$

Total emission values shall not differ by more than 7.5% from the total average emissions

$$7.5\% \text{ of the average} = \underline{0.42}$$

$$\text{Train 1 difference} = \underline{0.42}$$

$$\text{Train 2 difference} = \underline{0.42}$$

**PR - Proportional Rate Variation**

ASTM E2515 equation (16)

$$PR = \left[ \frac{\theta \times V_{mi} \times V_s \times T_m \times T_{si}}{\theta_i \times V_m \times V_{si} \times T_{mi} \times T_s} \right] \times 100$$

Where:

- $\theta$  = Total sampling time, min
- $\theta_i$  = Length of recording interval, 1 min
- $V_{mi}$  = Volume of gas sample measured by the dry gas meter during the "ith" time interval, dcf
- $V_m$  = Volume of gas sample as measured by dry gas meter, dcf
- $V_{si}$  = Average gas velocity in the dilution tunnel during the "ith" time interval, ft/sec
- $V_s$  = Average gas velocity in the dilution tunnel, ft/sec
- $T_{mi}$  = Absolute average dry gas meter temperature during the "ith" time interval, °R
- $T_m$  = Absolute average dry gas meter temperature, °R
- $T_{si}$  = Absolute average gas temperature in the dilution tunnel during the "ith" time interval, °R
- $T_s$  = Absolute average gas temperature in the dilution tunnel, °R

Sample calculation (for the first 1 minute interval of Train 1):

$$PR = \left( \frac{310 \times 1.565 \times 17.14 \times (82.0 + 460) \times (82.3 + 460)}{1 \times 49.73 \times 17.09 \times (85.2 + 460) \times (74.0 + 460)} \right) \times 100$$

$$PR = \underline{988} \%$$

**PM<sub>R</sub> – Particulate emissions for test run, g/hr**

ASTM E2780 equation (6)

$$PM_R = 60 (E_T/\theta)$$

Where,

E<sub>T</sub> = Total particulate emissions, grams

θ = Total length of full integrated test run, min

Sample Calculation:

$$E_T (\text{Dual train average}) = 5.62 \text{ g}$$

$$\theta = 310 \text{ min}$$

$$PM_R = 60 \times ( 5.62 / 310 )$$

$$PM_R = 1.09 \text{ g/hr}$$

**PM<sub>F</sub>** – Particulate emission factor for test run, g/dry kg of fuel burned  
ASTM E2780 equation (7)

$$PM_F = E_T / M_{FTAdb}$$

Sample Calculation:

$$E_T \text{ (Dual train average)} = 5.62 \text{ g}$$

$$M_{Bdb} = 4.45 \text{ kg}$$

$$PM_F = 5.62 / 4.45$$

$$PM_F = 1.26 \text{ g/kg}$$

*Model: Explorer I  
Hearth & Home technologies  
1445 North Highway  
Colville, WA 99114*

# **Section 4**

## **Owner's Manual**



# CAUTION: HOT WHILE IN OPERATION DO NOT TOUCH, KEEP CHILDREN AND CLOTHING AWAY. CONTACT MAY CAUSE SKIN BURNS.

**CAUTION: KEEP FURNISHINGS AND OTHER COMBUSTIBLE MATERIAL FAR AWAY FROM THE APPLIANCE. SEE NAMEPLATE AND INSTRUCTIONS CHAUD LORS DE L'OPÉRATION. NE PAS TOUCHER. GARDEZ LES ENFANTS ET LES VÊTEMENTS LOIN DE L'ESPACE DÉSIGNÉ DE L'APPAREIL. VOIR L'ÉTIQUETTE ET LES INSTRUCTIONS. DES BRÛLURES À LA PEAU. GARDEZ LES MEUBLES ET LES MATÉRIAUX COMBUSTIBLES LOIN DE L'ESPACE DÉSIGNÉ DE L'APPAREIL. VOIR L'ÉTIQUETTE ET LES INSTRUCTIONS.**

**LISTED ROOM HEATER, SOLID FUEL TYPE, MOBILE HOME INSTALLATIONS ONLY (UL 984-HUD).** For Use with Solid Wood Fuel Only

**PREVENT HOUSE FIRES** Install and use only in accordance with manufacturer's installation and operating instructions. Contact local building or fire officials about restrictions and installation inspections in your area. Do not obstruct the space beneath heater.

**WARNING - For Mobile Homes:** Do not install in a sleeping room. An outside combustion air inlet must be provided and unrestricted while unit is in use. Do not install in a room with a ceiling or floor. Ceilings and walls must be maintained. The stove must be properly grounded to the frame of the mobile home. Components required for mobile home installation: Outside Air Kit, Part Number OAK-ACC. Refer to manufacturers' instructions and local codes for precautions required for passing chimney through a combustible wall or ceiling and maximum offsets. Do not use any other chimney. Do not use other Connector Kits, such as the Builder's Kit. Do not use any other Connector Kits. Do not connect this unit to a chimney serving another appliance. Optional Components: Optional Blower, Part BK-ACC. Electrical Rating: 115 VAC, 1.2 Amps, 60 Hz. Route power cord away from unit. Do not route cord under or in front of appliance. **WARNING: Risk of electrical shock.** Disconnect power supply before servicing. Replace glass only with 5mm thick safety glass. Do not use any other type of glass or elevate fire. Build wood fire directly on grate or elevate fire. If heater or chimney connector glows, you are overfiring. Operate only with the fuel loading door closed. Open only to add fuel to the fire.

**FLOOR PROTECTION:** It is necessary to install a Type II floor protector no less than 3/8 inch (9.5mm) thick with a minimum R value of 1.06, a minimum of 16 inches (406mm) in front of glass, and 6 inches (152mm) to both sides of the fuel loading door. Open the door and measure 6 inches (152mm) from the side edge of the opening in the face of the appliance.

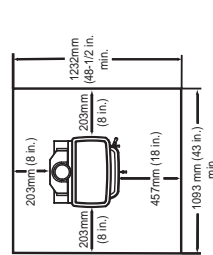
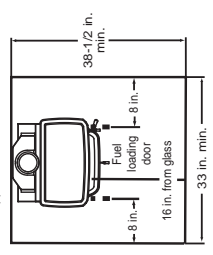

**APPAREIL DE CHAUFFAGE DE PIÈCE DE MAISON COMBUSTIBLE SOLIDE. PAS APPROUVÉ POUR MOBILE HOME INSTALLATIONS AU CANADA** Pour Usage Avec Bois Solide Seulement

**PRÉVENTION DES FEUX DE MAISON** Installez et utilisez en accord avec les instructions d'installation et d'opération du fabricant. Contactez le bureau de la construction ou le bureau des incendies au sujet des restrictions et des inspections d'installation dans votre voisinage. Ne pas obstruer l'espace en dessous de l'appareil. PAS APPROUVÉ POUR MOBILE HOME INSTALLATIONS AU CANADA!

Référez vous aux instructions du fabricant et des codes locaux pour les précautions requises pour passer une cheminée à travers un mur ou un plancher combustibles, et les compensations maximums. Inspectez et nettoyez la cheminée fréquemment. Sous certaines conditions, il se peut que la croûte s'accumule également. Ne pas connecter cet appareil à une cheminée servant un autre appareil. Options: Kit de ventilation: 115 VAC, 1,2 Amps, 60 Hz. Entrez le fil électrique de l'appareil. Ne pas faire passer le fil électrique au-dessus ou en dessous de l'appareil. **DANGER:** Il y a un risque de décharge électrique. Déconnectez le fil électrique de la prise de contact avant le service. Remplacez la vitre seulement avec une vitre céramique de 5 mm disponible chez votre fournisseur. N'élevez pas le feu. Baissez le feu de bois directement sur le foyer de cheminée rougissant, vous surchauffez. Opérez la cheminée avec précaution. Ne laissez pas la porte ouverte. Ouvrez la porte seulement lorsque vous devez ajouter des combustibles dans le feu.

**PROTECTION DU PLANCHER:** Il est nécessaire d'installer un plancher de protection de Type II pas moins de 3/8 de pouce (9,5mm) d'épaisseur avec une valeur minimale de R de 1,06, un minimum de 16 pouces (406mm) à l'avant ou, verre, et 6 pouces (152mm) de chaque côté de l'ouverture de la porte. Mesurez 6 pouces (152mm) de l'ouverture de la porte et mesurez 6 pouces (152mm) du bord latéral de l'ouverture dans la face de l'appareil.

Tested & Listed By **UL** **LABORATORIES, INC.** Portland Oregon USA  
**OMNI-TEST LABORATORIES, INC.**  
 REPORT: 0061W095T5  
 TESTED TO / TESTÉ À: ULC S645 1482-11 & 737-11  
 Certified to ULC S64 S627-00

**QUADRA-FIRE**  
 NOTHING BURNS LIKE A WOOD STOVE  
**EXPLORER I WOOD STOVE**

SERIAL NO. / NUMÉRO DE SÉRIE  
**007072** room for 14 x 875" SIN  
 1.5" x .375 Barcode Label

### VENT SPECIFICATIONS:

**SINGLE WALL:** Six inch (6 inches) (152mm) diameter, minimum 24 MSG black or blued steel connector pipe, with a listed factory-built UL 103HT\* Class "A" chimney, suitable for use with solid fuels, or a masonry chimney, and the referenced clearances.  
**DOUBLE WALL:** Six inch (6 inches) (152mm) diameter, listed double wall air insulated connector pipe with listed factory-built UL 103HT\* Class "A" chimney, or a masonry chimney and the referenced clearances.  
*\*In Canada must comply with Standard CAN/ULC-S629-M87 for the 650 degree Factory-built chimneys.*  
**MOBILE HOME (USA ONLY):** Use double wall pipe by Dura-Vent DVL, Selkirk Metalbestos DS or Security DL double wall connector pipe. Must be equipped with a spark arrester. Apply double wall clearances below when installing unit.

**MINIMUM CLEARANCES TO COMBUSTIBLES In Inches & (Millimeters)**  
 NOTE: All "A", "C", and "F" Dimensions are to inside diameter of the flue collar.

**INSTALLATION: FULL VERTICAL AND ALCOVE/Verticale complète et d'une alcôve**

	A	B	C	D	E	F	G	H	I	J
SINGLE WALL PIPE	17 (432)	12.5 (318)	24 (610)	11 (280)	12 (305)	18 (458)	53.5 (1359)		NA	NA
DOUBLE WALL PIPE	13.5 (343)	9 (227)	23 (585)	10 (254)	7.25 (184)	13.25 (337)	53.5 (1359)		NA	NA

**INSTALLATION: 90° ELBOW TOP OF STOVE THROUGH BACKWALL**

	A	B	C	D	E	F	G	H	I	J
SINGLE WALL PIPE	17 (432)	12.5 (318)	24 (610)	11 (280)	NA	NA	53.5 (1359)	18 (458)	NA	NA
DOUBLE WALL PIPE	12.5 (318)	8 (204)	23 (585)	10 (254)	NA	NA	53.5 (1359)	18 (458)	NA	NA

**INSTALLATION: HORIZONTAL THRU WALL**

	A	B	C	D	E	F	G	H	I	J
SINGLE & DOUBLE WALL PIPE	NA	8 (204)	24 (610)	11 (280)	NA	NA	53.5 (1359)	8 (204)	53.5 (1359)	CONDUIT DU MUR SIMPLE

**INSTALLATION: ALCOVE -** Six inch (6 inches) (152mm) diameter listed SINGLE WALL or DOUBLE WALL air insulated connector pipe with UL 103 HT listed factory-built Class "A" chimney, or a masonry chimney. (Mobile Home must be equipped with a spark arrester). Maximum depth of Alcove shall be no more than 48 inches (1219mm) from floor to bottom of ceiling, and the referenced clearances.

**INSTALLATION: ALCOVE:** De six (6) (152mm) de diamètre, le connecteur du conduit d'air isolé pour du mur simple au mur double avec une cheminée bâli en usine 103HT de Classe "A", ou une cheminée de briques. (Les maisons mobiles doivent être équipées d'un arrêt d'incendie). La profondeur maximum de l'alcôve ne doit pas être de plus de 48 inches (1219mm) avec une hauteur minimum de 84 inches (2133mm) la distance entre du plancher et plafond inférieur, et des espaces libres alloués.

**SPÉCIFICATIONS DE LA VENTILATION:**  
**MUR SIMPLE:** De six (6) (152mm) de diamètre, le connecteur de conduit de minimum d'épaisseur ou bleu de minimum de 24MSG, avec une cheminée bâli en usine UL 103HT\* de Classe "A", adéquate pour usage avec les combustions solides, ou une cheminée de briques, avec espaces libres référés.  
**MUR DOUBLE:** De six (6) (152mm) de diamètre, le connecteur du conduit d'air isolé pour mur double avec une cheminée bâli en usine UL 103HT\* de Classe "A", ou une cheminée de briques, avec espaces libres alloués.  
*\*Au Canada doit conformer à CAN/ULC-S629-M87 la norme pour 650 degré C cheminée Factory-built chimneys.*  
**MAISON MOBILE:** PAS APPROUVÉ POUR MOBILE HOME INSTALLATIONS AU CANADA

**ESPACES LIBRES MINIMUM DES MATÉRIAUX COMBUSTIBLES En Pouces & (millimètres)**  
 NOTE: Toutes les dimensions "A", "C", et "F" sont à partir du diamètre intérieur de l'entree du conduit.

**INSTALLATION: HORIZONTAL THRU WALL**

	A	B	C	D	E	F	G	H	I	J
SINGLE & DOUBLE WALL PIPE	NA	8 (204)	24 (610)	11 (280)	NA	NA	53.5 (1359)	8 (204)	53.5 (1359)	CONDUIT DU MUR DOUBLE

**INSTALLATION: ALCOVE -** Six inch (6 inches) (152mm) diameter listed SINGLE WALL or DOUBLE WALL air insulated connector pipe with UL 103 HT listed factory-built Class "A" chimney, or a masonry chimney. (Mobile Home must be equipped with a spark arrester). Maximum depth of Alcove shall be no more than 48 inches (1219mm) from floor to bottom of ceiling, and the referenced clearances.

**INSTALLATION: ALCOVE:** De six (6) (152mm) de diamètre, le connecteur du conduit d'air isolé pour du mur simple au mur double avec une cheminée bâli en usine 103HT de Classe "A", ou une cheminée de briques. (Les maisons mobiles doivent être équipées d'un arrêt d'incendie). La profondeur maximum de l'alcôve ne doit pas être de plus de 48 inches (1219mm) avec une hauteur minimum de 84 inches (2133mm) la distance entre du plancher et plafond inférieur, et des espaces libres alloués.

**BACKWALL/SIDEWALL MUR ARRIÈRE/MUR DE CÔTÉ**  
**CORNER INSTALLATION INSTALLATION DU COIN**  
**90° OFF TOP LIP & OUT CEILING CLEARANCE ESPACE LIBRE DU PLAFOND AVEC 90° DE COURBURE**  
**HORIZONTAL THRU WALL HORIZONTALE AU MUR**

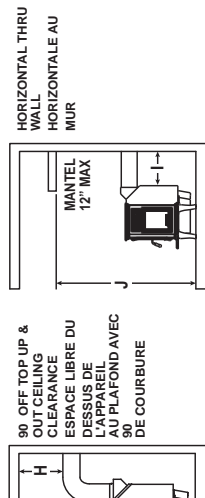

Manufactured by:  
**HEARTH HOME TECHNOLOGIES**  
 1445 N. Highway, Colville, WA 99114  
 www.quadrare.com

2015 2016 2017  
 JAN FEB MAR APR MAY JUN  
 JUL AUG SEP OCT NOV DEC

**DO NOT REMOVE THIS LABEL / NE PAS ENLEVER L'ÉTIQUETTE**

U.S. ENVIRONMENTAL PROTECTION AGENCY  
 Certified to comply with 2015 particulate emission standards at 2.2 g/hr EPA method 29, ASTM E2515. Not approved for sale after May 15, 2020.

This wood heater needs periodic cleaning for safe operation. Consult the owner's manual for further information. U.S. and Canadian federal regulations to operate this wood heater in a manner inconsistent with the operating instructions in the owner's manual.



Owner's Manual



Installation Manual

Made in U.S.A. of U.S. and imported parts.

Fabrique aux États-Unis d'Amérique par des pièces d'origine américaine et pièces importées.

7062-195



# Installation Manual

## Installation & Appliance Set-Up

**INSTALLER:** Leave this manual with party responsible for use and operation.

**OWNER:** Retain this manual for future reference.

**NOTICE: DO NOT DISCARD THIS MANUAL**

# QUADRA-FIRE®

Explorer I

Model(s):

**EXPLR-I-MBK**

**EXPLR-I-PFT**

**EXPLR-I-PBK**

**EXPLR-I-PMH**

**EXPLR-I-PDB**

**NOTICE: DO NOT DISCARD THIS MANUAL**

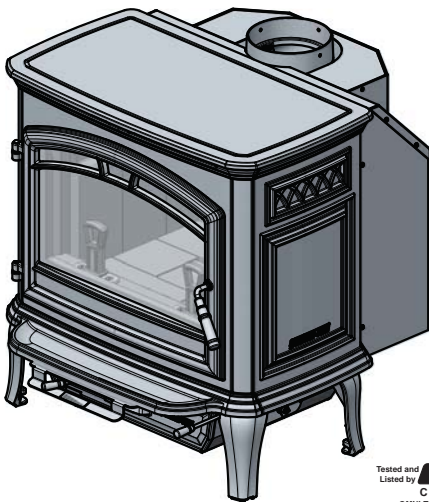

Tested and  
Listed by  Portland  
Oregon USA  
OMNI-Test Laboratories, Inc.



### WARNING



If the information in these instructions is not followed exactly, a fire may result causing property damage, personal injury, or death.

- Do not store or use gasoline or other flammable vapors and liquids in the vicinity of this or any other appliance.
- Do not over-fire - If heater or chimney connector glows, you are over-firing. Over-firing will void your warranty.
- Comply with all minimum clearances to combustibles as specified. Failure to comply may cause house fire.



### WARNING



#### HOT SURFACES!

Glass and other surfaces are hot during operation AND cool down.

**Hot glass will cause burns.**

- Do not touch glass until it is cooled
- NEVER allow children to touch glass
- Keep children away
- CAREFULLY SUPERVISE children in same room as fireplace.
- Alert children and adults to hazards of high temperatures
- **High temperatures may ignite clothing or other flammable materials.**
- Keep clothing, furniture, draperies and other flammable materials away.



### WARNING



#### Fire Risk.

For use with solid wood fuel only. Other fuels may over-fire and generate poisonous gases (i.e. carbon monoxide).

myhht  
FACTORY  
training

Installation and service of this appliance should be performed by qualified personnel. Hearth & Home Technologies recommends HHT Factory Trained or NFI certified professionals.



### NOTE

To obtain a French translation of this manual, please contact your dealer or visit [www.quadrafire.com](http://www.quadrafire.com)

Pour obtenir une traduction française de ce manuel, s'il vous plaît contacter votre revendeur ou visitez [www.quadrafire.com](http://www.quadrafire.com)

 **Safety Alert Key:**

- **DANGER!** Indicates a hazardous situation which, if not avoided will result in death or serious injury.
- **WARNING!** Indicates a hazardous situation which, if not avoided could result in death or serious injury.
- **CAUTION!** Indicates a hazardous situation which, if not avoided, could result in minor or moderate injury.
- **NOTICE:** Indicates practices which may cause damage to the appliance or to property.

**TABLE OF CONTENTS**

<p><b>1 Important Safety Information.....3</b></p> <p style="padding-left: 20px;">A. Appliance Certification .....3</p> <p style="padding-left: 20px;">B. BTU &amp; Efficiency Specifications.....3</p> <p style="padding-left: 20px;">C. Mobile Home Approved (USA ONLY) .....3</p> <p style="padding-left: 20px;">D. Glass Specifications .....3</p> <p style="padding-left: 20px;">E. Non-Combustible Materials .....3</p> <p style="padding-left: 20px;">F. Combustible Materials.....3</p> <p><b>2 Getting Started.....4</b></p> <p style="padding-left: 20px;">A. Design and Installation Considerations .....4</p> <p style="padding-left: 20px;">B. Fire Safety .....4</p> <p style="padding-left: 20px;">C. Negative Pressure.....5</p> <p style="padding-left: 20px;">D. Tools And Supplies Needed.....5</p> <p style="padding-left: 20px;">E. Inspect Appliance and Components .....5</p> <p style="padding-left: 20px;">F. Install Checklist .....6</p> <p><b>3 Dimensions and Clearances.....7</b></p> <p style="padding-left: 20px;">A. Appliance Dimensions .....7</p> <p style="padding-left: 20px;">B. Clearances to Combustibles.....8</p> <p style="padding-left: 20px;">C. Locating Your Appliance &amp; Chimney.....9</p> <p style="padding-left: 20px;">D. Chimney Termination Requirements .....9</p> <p style="padding-left: 20px;">E. 2-10-3 Rule ..... 10</p>	<p><b>4 Chimney Systems..... 11</b></p> <p style="padding-left: 20px;">A. Venting Components .....11</p> <p style="padding-left: 20px;">B. Chimney Systems.....11</p> <p style="padding-left: 20px;">C. Installing Chimney Components.....13</p> <p><b>5 Appliance Set-Up ..... 14</b></p> <p style="padding-left: 20px;">A. Hearth Protection Requirements .....14</p> <p style="padding-left: 20px;">B. Outside Air Kit Installation .....15</p> <p style="padding-left: 20px;">C. Blower (Optional).....16</p> <p style="padding-left: 20px;">D. Reversible Flue Collar and Horizontal Flue Heat Shield ..17</p> <p><b>6 Mobile Home Installation..... 18</b></p> <p><b>7 Accessory List ..... 19</b></p>
---	--

# 1 Important Safety Information

## A. Appliance Certification

<b>Model:</b>	Explorer I
<b>Laboratory:</b>	OMNI Test Laboratories Inc.
<b>Report No:</b>	0061WS091S
<b>Type:</b>	Safety
<b>Standard:</b>	UL 1482-11 & 737-11; ULC S627-00

The Quadra-Fire Explorer I meets the U.S. Environmental Protection Agency's 2015 particulate emission standards.

## B. BTU & Efficiency Specifications

EPA Certification Number:	PENDING
EPA Certified Emissions:	2.2 grams per hour
*LHV Tested Efficiency:	80.2%
**HHV Tested Efficiency:	74.1%
***EPA BTU Output:	12,800 to 32,000 / hr.
****Peak BTU/Hour Output:	52,400
Vent Size:	6 inches
Firebox Size:	1.68 cubic feet
Recommended Log Length	16 inches
Fuel Orientation:	Side to Side
Fuel	Seasoned Cord Wood
*Weighted average LHV (Low Heating Value) efficiency using Douglas Fir dimensional lumber and data collected during EPA emission test. LHV assumes the moisture is already in a vapor state so there is no loss in energy to vaporize.	
**Weighted average HHV (High Heating Value) efficiency using Douglas Fir dimensional lumber and data collected during EPA emission test. HHV includes the energy required to vaporize the water in the fuel.	
***A range of BTU outputs based on EPA Default Efficiency and the burn rates from the low and high EPA tests, using Douglas Fir dimensional lumber.	
****The peak BTU out of the appliance is calculated using the maximum first hour burn rate from the High EPA Test and the BTU content of cordwood (8600) times the efficiency.	

## C. Mobile Home Approved (USA ONLY)

- This appliance is approved for mobile home installations in the USA when not installed in a sleeping room and when an outside combustion air inlet is provided.
- The structural integrity of the mobile home floor, ceiling, and walls must be maintained.
- The appliance must be properly grounded to the frame of the mobile home with #8 copper ground wire.
- Outside Air Kit, part OAK-ACC must be installed in a mobile home installation.

NOTE: Hearth & Home Technologies, manufacturer of this appliance, reserves the right to alter its products, their specifications and/or price without notice.

## WARNING



### Fire Risk.

Hearth & Home Technologies disclaims any responsibility for, and the warranty will be voided by, the following actions:

- Installation and use of any damaged appliance.
- Modification of the appliance.
- Installation other than as instructed by Hearth & Home Technologies.
- Installation and/or use of any component part not approved by Hearth & Home Technologies.
- Operating appliance without fully assembling all components.
- Operating appliance without legs attached (if supplied with it).
- Do NOT Over-fire - If appliance or chimney connector glows you are over-firing.

Any such action that may cause a fire hazard.

NOTE: This installation must conform with local codes. In the absence of local codes you must comply with the UL1482-07, (UM) 84-HUD and NFPA211 in the U.S.A. and the ULC S627-00 and CAN/CSA-B365 Installation Codes in Canada. **NOT APPROVED FOR MOBILE HOME INSTALLATIONS IN CANADA!**

Improper installation, adjustment, alteration, service or maintenance can cause injury or property damage.

For assistance or additional information, consult a qualified installer, service agency or your dealer.

Hearth & Home Technologies WILL NOT warranty appliances that exhibit evidence of over-firing. Evidence of over-firing includes, but is not limited to:

- Warped air tube
- Deteriorated refractory brick retainers
- Deteriorated baffle and other interior components

## D. Glass Specifications

This appliance is equipped with 5mm ceramic glass.

Replace glass only with 5mm ceramic glass. Please contact your dealer for replacement glass.

## E. Non-Combustible Materials

Material which will not ignite and burn, composed of any combination of the following:

- Steel
- Brick
- Concrete
- Glass
- Plaster
- Iron
- Tile
- Slate

Materials reported as passing **ASTM E 136, Standard Test Method for Behavior of Metals, in a Vertical Tube Furnace of 750° C.**

## F. Combustible Materials

Material made of/or surfaced with any of the following materials:

- Wood
- Plant Fibers
- Plywood/OSB
- Compressed Paper
- Plastic
- Sheet Rock (drywall)

Any material that can ignite and burn: flame proofed or not, plastered or un-plastered.

# Install Guide

## 2 Getting Started

### A. Design and Installation Considerations

Consideration must be given to:

- Safety
- Convenience
- Traffic flow
- Chimney and chimney connector required



It is a good idea to plan your installation on paper, using exact measurements for clearances and floor protection, before actually beginning the installation. If you are not using an existing chimney, place the appliance where there will be a clear passage for a factory-built listed chimney through the ceiling and roof.

We recommend that a qualified building inspector and your insurance company representative review your plans before and after installation.

If this appliance is in an area where children may be near it is recommended that you purchase a decorative barrier to go in front of the appliance. Remember to always keep children away while it is operating and do not let anyone operate this appliance unless they are familiar with the operating instructions.

<b>CAUTION</b>
<p>Check building codes prior to installation.</p> <ul style="list-style-type: none"> <li>• Installation <b>MUST</b> comply with local, regional, state and national codes and regulations.</li> <li>• Consult insurance carrier, local building, fire officials or authorities having jurisdiction about restrictions, installation inspection, and permits.</li> </ul>

 <b>WARNING</b>
<p><b>Asphyxiation Risk.</b></p> <ul style="list-style-type: none"> <li>• <b>DO NOT CONNECT THIS APPLIANCE TO A CHIMNEY FLUE SERVICING ANOTHER APPLIANCE.</b></li> <li>• <b>DO NOT CONNECT TO ANY AIR DISTRIBUTION DUCT OR SYSTEM.</b></li> </ul> <p>May allow flue gases to enter the house.</p>

 <b>WARNING</b>
<div style="display: flex; align-items: center;">  <div> <p><b>Fire Risk.</b></p> <p>Hearth &amp; Home Technologies disclaims any responsibility for, and the warranty will be voided by, the following actions:</p> <ul style="list-style-type: none"> <li>• Installation and use of any damaged appliance.</li> <li>• Modification of the appliance.</li> <li>• Installation other than as instructed by Hearth &amp; Home Technologies.</li> <li>• Installation and/or use of any component part not approved by Hearth &amp; Home Technologies.</li> <li>• Operating appliance without fully assembling all components.</li> <li>• Operating appliance without legs attached (if supplied with appliance).</li> <li>• Do NOT Over-fire - If appliance or chimney connector glows, you are over-firing.</li> </ul> <p><b>Any such action that may cause a fire hazard.</b></p> </div> </div>



### B. Fire Safety

To provide reasonable fire safety, the following should be given serious consideration:

1. Install at least one smoke detector on each floor of your home to ensure your safety. They should be located away from the heating appliance and close to the sleeping areas. Follow the smoke detector manufacturer's placement and installation instructions, and be sure to maintain regularly.
2. A conveniently located Class A fire extinguisher to contend with small fires resulting from burning embers.
3. A CO detector should be installed in the room with the appliance.
4. A practiced evacuation plan, consisting of at least two escape routes.
5. A plan to deal with a chimney fire as follows:  
 In the event of a chimney fire:
  - a. Evacuate the house immediately
  - b. Notify fire department.

<p><b>NOTICE:</b> HEARTH &amp; HOME TECHNOLOGIES ASSUMES NO RESPONSIBILITY FOR THE IMPROPER PERFORMANCE OF THE APPLIANCE SYSTEM CAUSED BY:</p> <ul style="list-style-type: none"> <li>• Inadequate draft due to environmental conditions</li> <li>• Downdrafts</li> <li>• Tight sealing construction of the structure</li> <li>• Mechanical exhausting devices</li> <li>• Overdrafting caused by excessive chimney heights</li> <li>• Ideal performance is with height of chimney between 14-16 feet (4.26-4.88m) measured from the base of the appliance.</li> </ul>
---

### C. Negative Pressure

 <b>WARNING</b>	
	<p><b>Asphyxiation Risk.</b></p> <ul style="list-style-type: none"> <li>• Negative pressure can cause spillage of combustion fumes, soot and carbon monoxide.</li> <li>• Appliance needs to draft properly for safety.</li> </ul>

Negative pressure results from the imbalance of air available for the appliance to operate properly. It can be strongest in lower levels of the house.

Causes include:

- Exhaust fans (kitchen, bath, etc.)
- Range hoods
- Combustion air requirements for furnaces, water heaters and other combustion appliances
- Clothes dryers
- Location of return-air vents to furnace or air conditioning
- Imbalances of the HVAC air handling system
- Upper level air leaks such as:
  - Recessed lighting
  - Attic hatch
  - Duct leaks

To minimize the effects of negative air pressure:

- Install the outside air kit with the intake facing prevailing winds during the heating season
- Ensure adequate outdoor air for all combustion appliances and exhaust equipment
- Ensure furnace and air conditioning return vents are not located in the immediate vicinity of the appliance
- Avoid installing the appliance near doors, walkways or small isolated spaces
- Recessed lighting should be a “sealed can” design
- Attic hatches weather stripped or sealed
- Attic mounted duct work and air handler joints and seams taped or sealed
- Basement installations should be avoided

### D. Tools And Supplies Needed

Before beginning the installation be sure the following tools and building supplies are available:

Reciprocating saw	Framing material
Pliers	High temp caulking material
Hammer	Gloves
Phillips screwdriver	Framing square
Flat blade screwdriver	Electric drill and bits
Plumb line	Safety glasses
Level	Tape measure
Misc. screws and nails	
1/2-3/4 in. length, #6 or #8 self-drilling screws	

### E. Inspect Appliance and Components

- Remove appliance and components from packaging and inspect for damage.
- Report to your dealer any parts damaged in shipment.
- **Read all the instructions before starting the installation. Follow these instructions carefully during the installation to ensure maximum safety and benefit.**

 <b>WARNING</b>	
	<p><b>Fire Risk.</b></p> <p>Inspect appliance and components for damage. Damaged parts may impair safe operation.</p> <ul style="list-style-type: none"> <li>• Do NOT install damaged components.</li> <li>• Do NOT install incomplete components.</li> <li>• Do NOT install substitute components.</li> </ul> <p>Report damaged parts to dealer.</p>

**F. Install Checklist**

**ATTENTION INSTALLER:  
Follow this Standard Work Checklist**

This standard work checklist is to be used by the installer in conjunction with, not instead of, the instructions contained in this installation manual.

Customer: \_\_\_\_\_  
 Date Installed: \_\_\_\_\_  
 Lot/Address: \_\_\_\_\_  
 Location of Appliance: \_\_\_\_\_  
 Installer: \_\_\_\_\_  
 Dealer/ Distributor Phone #: \_\_\_\_\_  
 Serial #: \_\_\_\_\_  
 Model (Circle one): EXPLR-I-MBK EXPLR-I-PDB EXPLR-I-PBK EXPLR-I-PMH EXPLR-I-PFT

**WARNING! Risk of Fire or Explosion!** Failure to install appliance according to these instructions can lead to a fire or explosion.

**Appliance Install**

Verified clearances to combustibles.  
 Appliance is leveled and connector is secured to appliance.  
 Hearth extension size/height decided.  
 Outside air kit installed.  
 Floor protection requirements have been met.  
 If appliance is connected to a masonry chimney, it should be cleaned and inspected by a professional. If installed to a factory built metal chimney, the chimney must be installed according to the manufacturer's instructions and clearances.

**YES**

<input type="checkbox"/>
<input type="checkbox"/>
<input type="checkbox"/>
<input type="checkbox"/>
<input type="checkbox"/>
<input type="checkbox"/>

**IF NO, WHY?**

_____
_____
_____
_____
_____
_____

**Chimney Section 4**

Chimney configuration complies with diagrams.  
 Chimney installed, locked and secured in place with proper clearance.  
 Chimney meets recommended height requirements (14-16 feet).  
 Roof flashing installed and sealed.  
 Terminations installed and sealed.

<input type="checkbox"/>
<input type="checkbox"/>
<input type="checkbox"/>
<input type="checkbox"/>
<input type="checkbox"/>

_____
_____
_____
_____
_____

**Clearances Section 3**

Combustible materials not installed in non-combustible areas.  
 Verified all clearances meet installation manual requirements.  
 Mantels and wall projections comply with installation manual requirements.  
 Protective hearth strips and hearth extension installed per manual requirements.

<input type="checkbox"/>
<input type="checkbox"/>
<input type="checkbox"/>
<input type="checkbox"/>

_____
_____
_____
_____

**Appliance Setup Section 5**

All packaging and protective materials removed.  
 Firebrick, baffle and ceramic blanket installed correctly.  
 All labels have been removed from the door.  
 All packaging materials are removed from inside/under the appliance.  
 Manual bag and all of its contents are removed from inside/under the appliance and given to the party responsible for use and operation.

<input type="checkbox"/>
<input type="checkbox"/>
<input type="checkbox"/>
<input type="checkbox"/>

_____
_____
_____
_____

**Hearth & Home Technologies recommends the following:**

- Photographing the installation and copying this checklist for your file.
- That this checklist remain visible at all times on the appliance until the installation is complete.

**Comments:** Further description of the issues, who is responsible (Installer/Builder/Other Trades, etc.) and corrective action needed:  
 Comments communicated to party responsible \_\_\_\_\_ by \_\_\_\_\_ on \_\_\_\_\_  
 (Builder/Gen. Contractor) (Installer) (Date)



# 3 Dimensions and Clearances

## A. Appliance Dimensions

NOTE: Flue Collar size is 6 inch (152mm) diameter (ID)

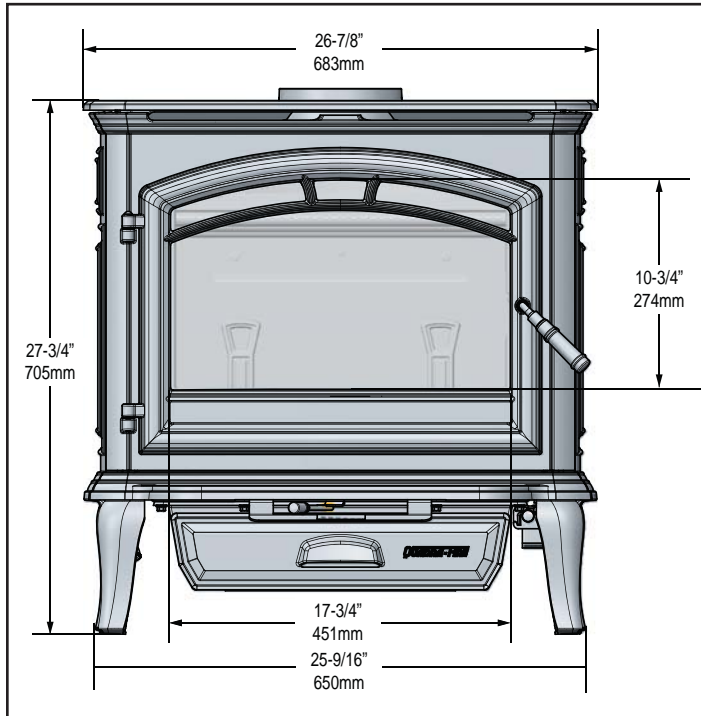

Figure 7.1 Front View

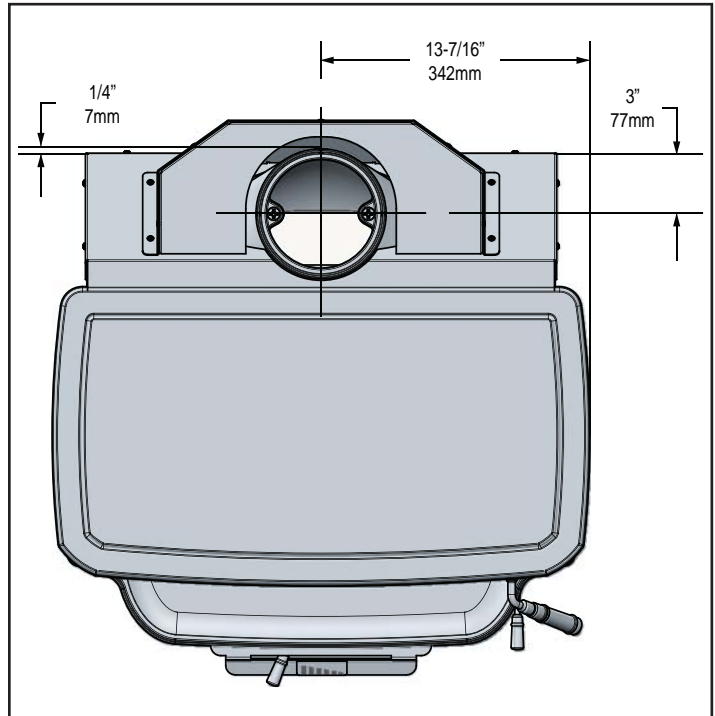

Figure 7.3 Top View

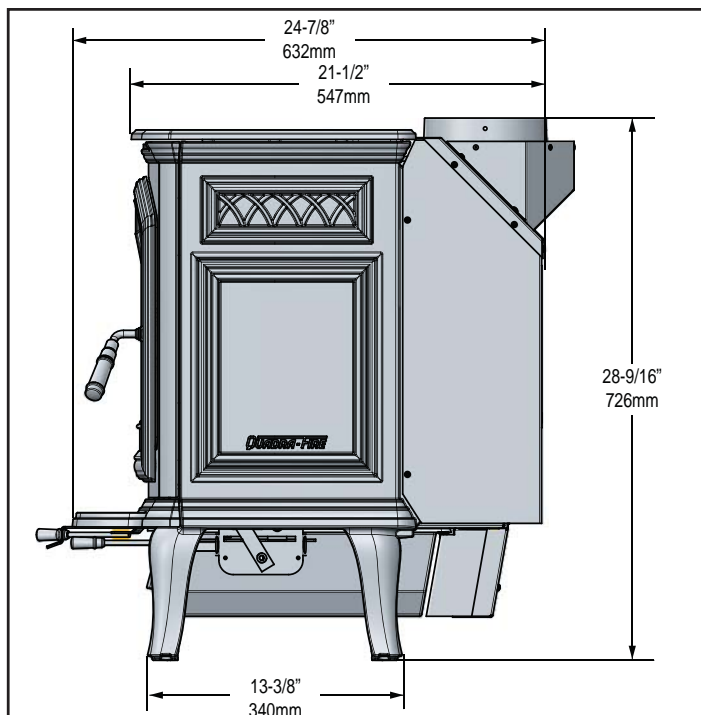

Figure 7.2 Side View with vertical flue

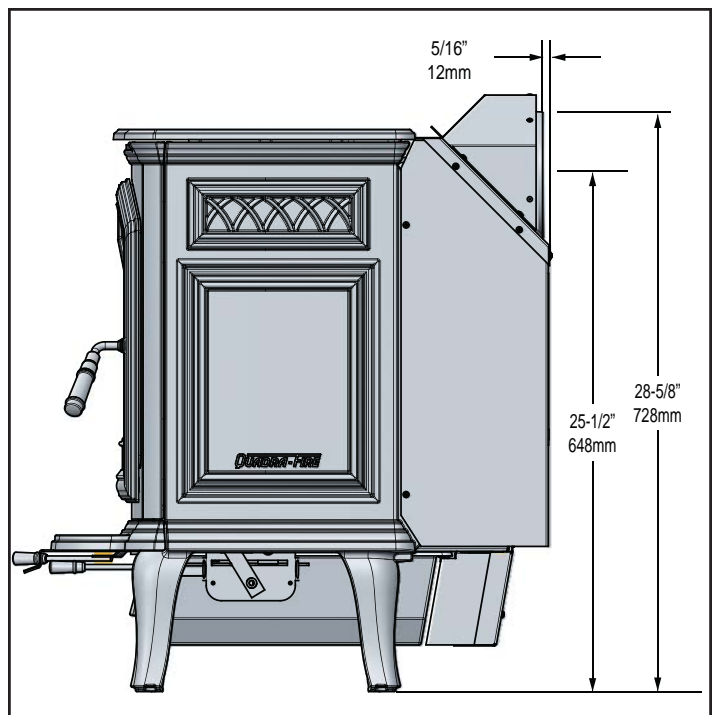

Figure 7.4 Side View with horizontal flue



**B. Clearances to Combustibles**

NOTE: A, C and F measurements are to center of flue

	A	B	C	D	E	F	G	H*
<b>Vertical Install Through Ceiling And Alcove</b>								
SINGLE WALL PIPE	17 [432]	12-1/2 [318]	24 [610]	11 [280]	12 [305]	18 [458]	53-1/2 [1359]	*
DOUBLE WALL PIPE	13-1/2 [343]	9 [227]	23 [585]	10 [254]	7-1/4 [184]	13-1/4 [337]	53-1/2 [1359]	*
<b>Horizontal Install Through Back Wall</b>								
SINGLE & DOUBLE WALL PIPE	N/A	8 [204]	24 [610]	11 [280]	N/A	N/A	53-1/2 [1359]	*
<b>90° Elbow Off The Top Of The Appliance, Then Through Back Wall</b>								
SINGLE WALL PIPE	17 [432]	12-1/2 [318]	24 [610]	11 [280]	N/A	N/A	53-1/2 [1359]	18 [458] **
DOUBLE WALL PIPE	12-1/2 [318]	8 [204]	23 [585]	10 [254]	N/A	N/A	53-1/2 [1359]	18 [458]
<b>INSTALLATION: ALCOVE</b> - Six inch (6") [152] diameter listed DOUBLE WALL air insulated connector pipe with UL 103 HT listed factory-built Class "A" chimney, or a masonry chimney. (Mobile Home must be equipped with a spark arrestor.) Maximum depth of Alcove shall be no more than 48" [1220] with a minimum height of 84" [2134] to top of appliance, and the referenced clearances. Canada must comply with CAN/ULC-S269 M87 for the 650° factory built chimney								

\* Follow Pipe Manufacturer's clearances  
 \*\* Acceptable per NFPA 211

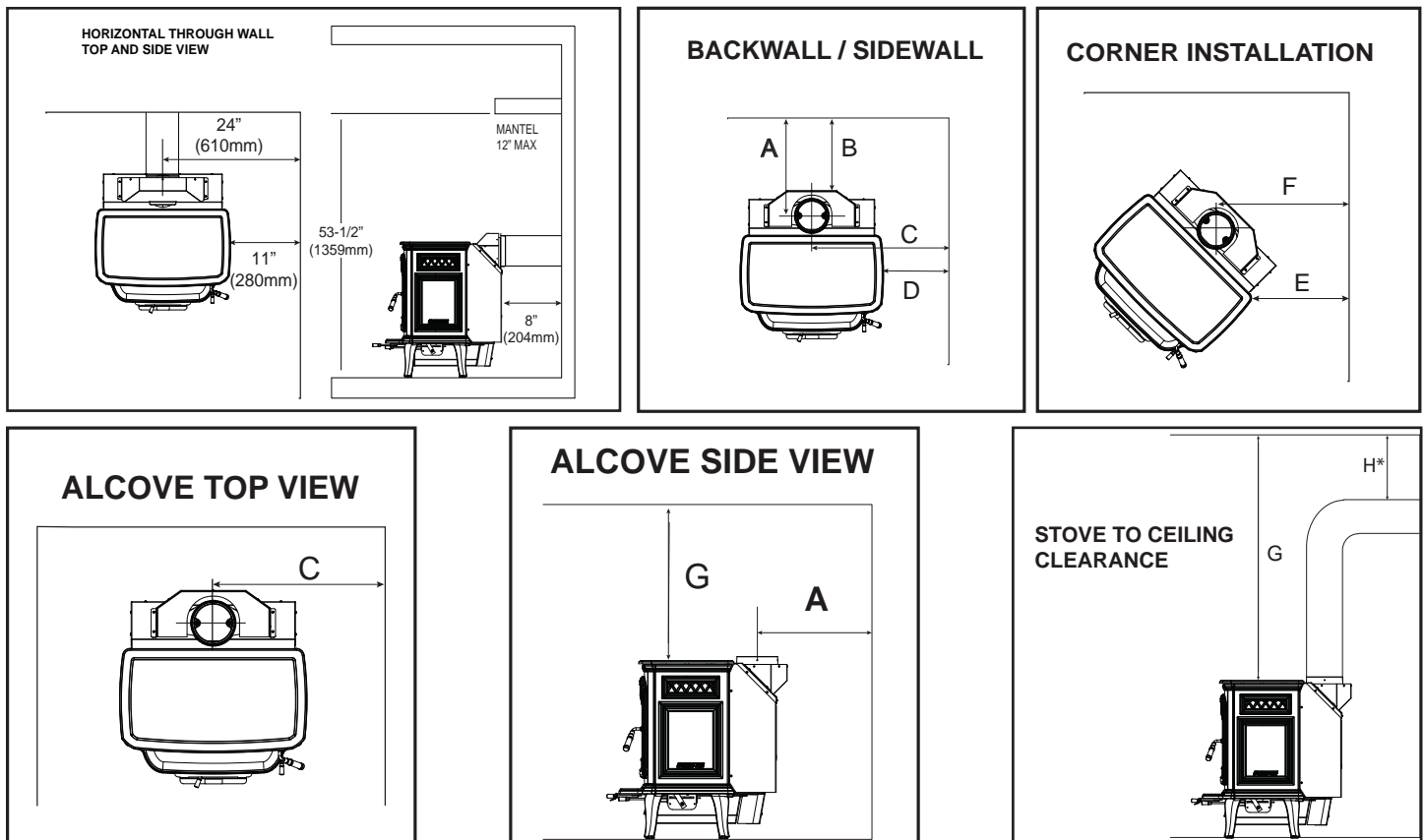

**NOTE: Clearances may only be reduced by means approved by the regulatory authority having jurisdiction**

**WARNING**

**Fire Risk.**

- Comply with all minimum clearances to combustibles as specified.
- Failure to comply may cause house fire.

### C. Locating Your Appliance & Chimney

Location of the appliance and chimney will affect performance. As shown in **Figure 9.1** the chimney should:

- Install through the warm space enclosed by the building envelope. This helps to produce more draft, especially during lighting and die down of the fire.
- Penetrate the highest part of the roof. This minimizes the affects of wind turbulence and down drafts.

- Consider the appliance location in order to avoid floor and ceiling attic joists and rafters.
- Locate termination cap away from trees, adjacent structures, uneven roof lines and other obstructions.

Your local dealer is the expert in your geographic area and can usually make suggestions or discover solutions that will easily correct your flue problem.

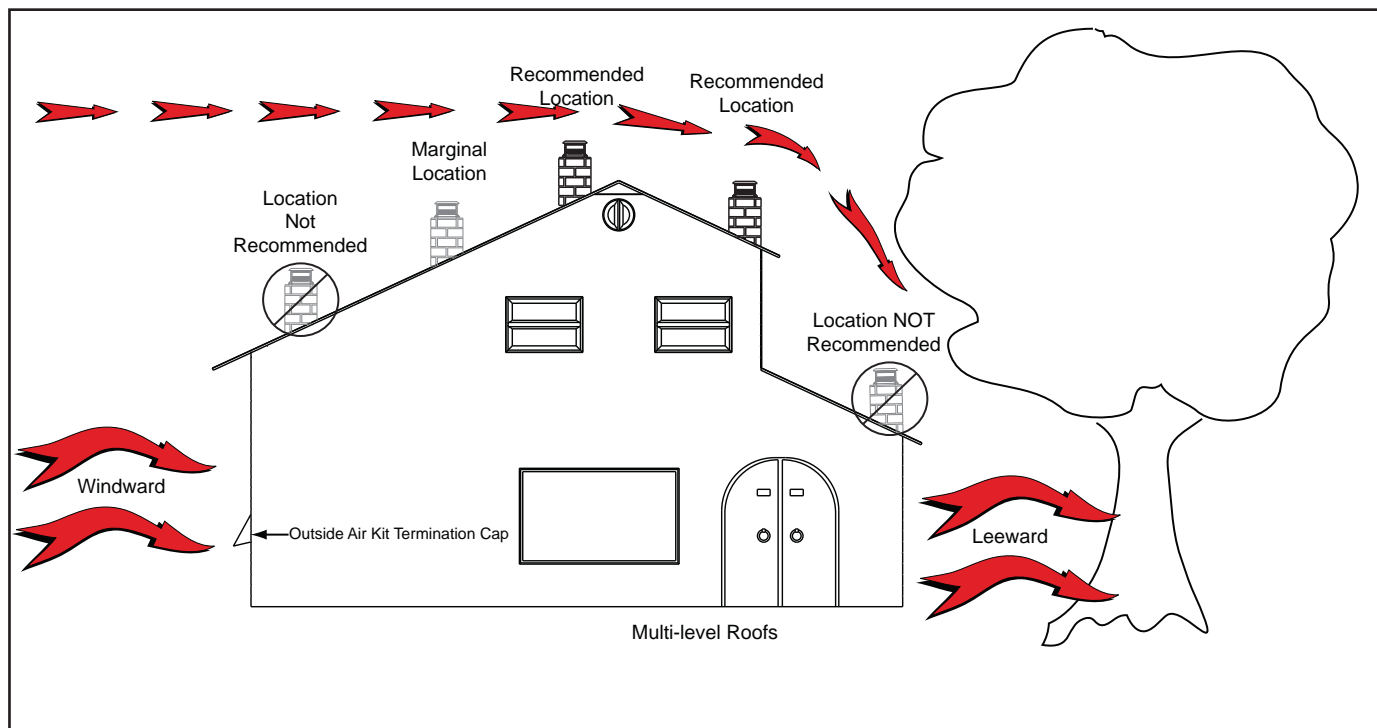

Figure 9.1

### D. Chimney Termination Requirements

Follow manufacturer's instructions for clearance, securing flashing and terminating the chimney. **Fig. 10.1 & 10.2**

- Must have an approved and Listed cap
- Must not be located where it will become plugged by snow or other material
- Must terminate at least 3 feet (91cm) above the roof **and** at least 2 feet (61cm) above any portion of the roof within 10 feet (305cm).
- Must be located away from trees or other structures

**NOTICE:** Locating the appliance in a basement or in a location of considerable air movement can cause intermittent smoke spillage from appliance. Do not locate appliance near

- Frequently open doors
- Central heat outlets or returns

**NOTICE:**

- Chimney performance may vary.
- Trees, buildings, roof lines and wind conditions affect performance.
- Chimney height may need adjustment if smoking or overdraft occurs.

E. 2-10-3 Rule

These are safety requirements and are not meant to assure proper flue draft.

This appliance is made with a 6 inch (152mm) diameter chimney connector as the flue collar on the appliance.

- Changing the diameter of the chimney can affect draft and cause poor performance.
- It is not recommended to use offsets and elbows at altitudes above 4000 feet above sea level and or when there are other factors that affect flue draft.

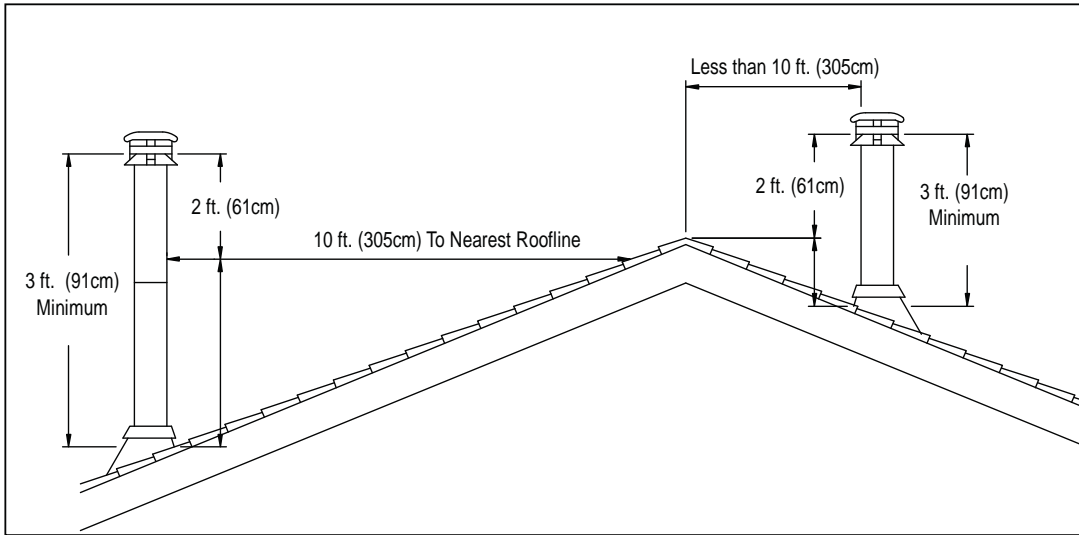

Pitched Roof

Figure 10.1

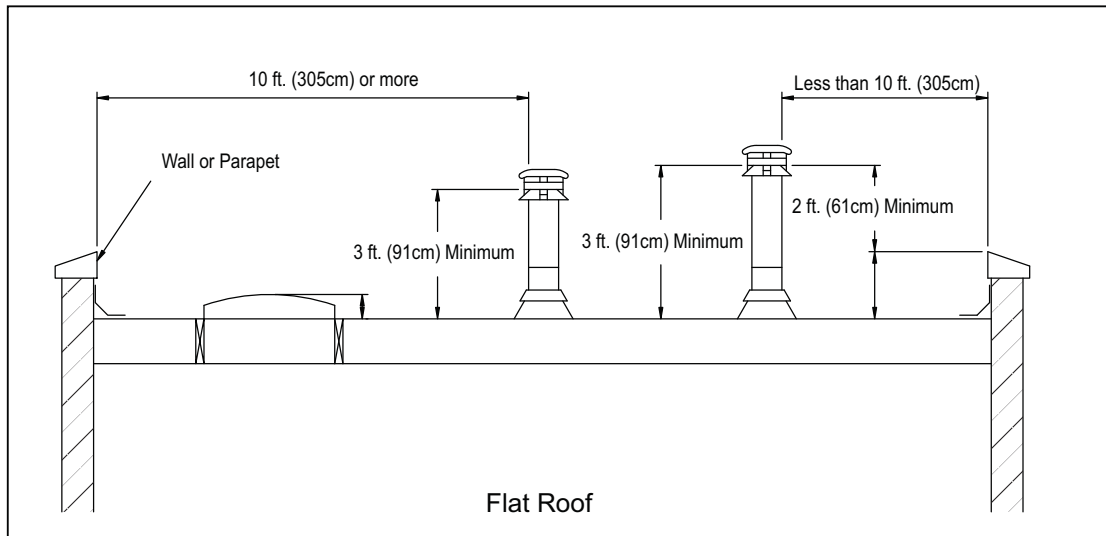

Flat Roof

Figure 10.2

# 4 Chimney Systems

## A. Venting Components

### Chimney Connector:

It is also known as flue pipe or appliance pipe. The chimney connector joins the appliance to the chimney. It must be a 6 inch (152mm) minimum diameter 24 gauge mild steel black or 26 gauge blued steel, or an approved air-insulated double wall venting pipe.

### Thimble:

A manufactured or site-constructed device installed in combustible walls through which the chimney connector passes to the chimney. It is intended to keep the walls from igniting. Site constructed thimbles must meet NFPA 211 Standards. Prefabricated must be suitable for use with selected chimney and meet UL103 Type HT Standards. Follow instructions provided by the manufacturer for manufactured thimbles for masonry chimney and prefabricated chimneys.

### Chimney:

The chimney can be new or existing, masonry or prefabricated and must meet the following minimum requirements specified in Section 4B.

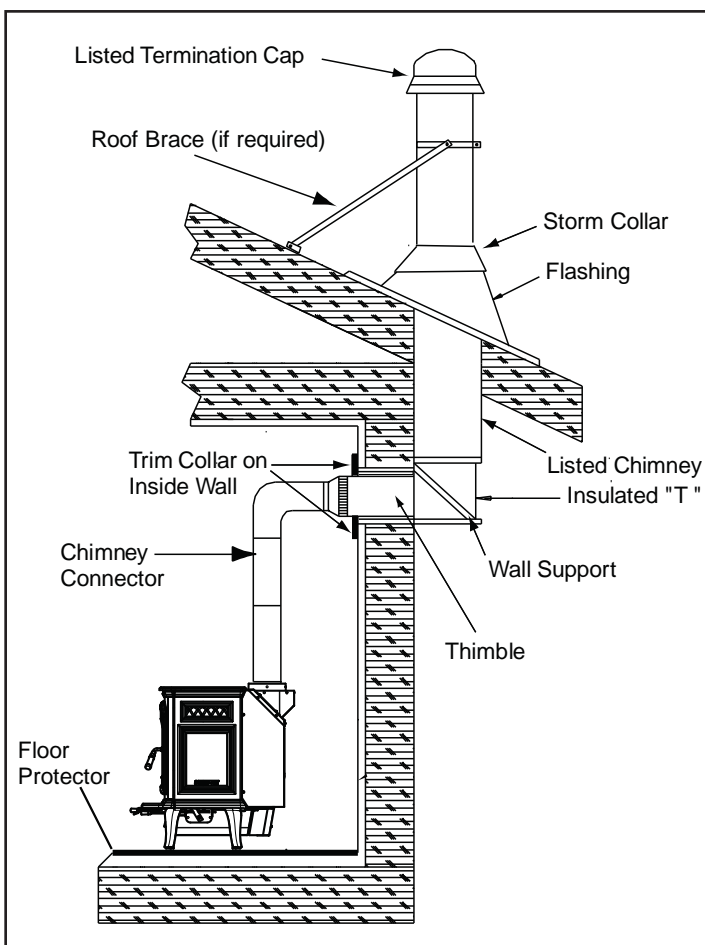

Figure 11.1 Prefabricated Exterior Chimney

## B. Chimney Systems

### Prefabricated Metal Chimney

- Must be minimum 6 inch (152mm) diameter (ID) high temperature chimney listed to UL 103 HT (2100°F) or ULC S629M.
- Must use components required by the manufacturer for installation.
- Must maintain clearances required by the manufacturer for installation.
- Refer to manufacturers instructions for installation.

**NOTE:** In Canada when using a factory-built chimney it must be safety listed, **Type UL103 HT (2100°F) CLASS "A"** or conforming to **CAN/ULC-S629M, STANDARD FOR 650°C FACTORY-BUILT CHIMNEYS.**

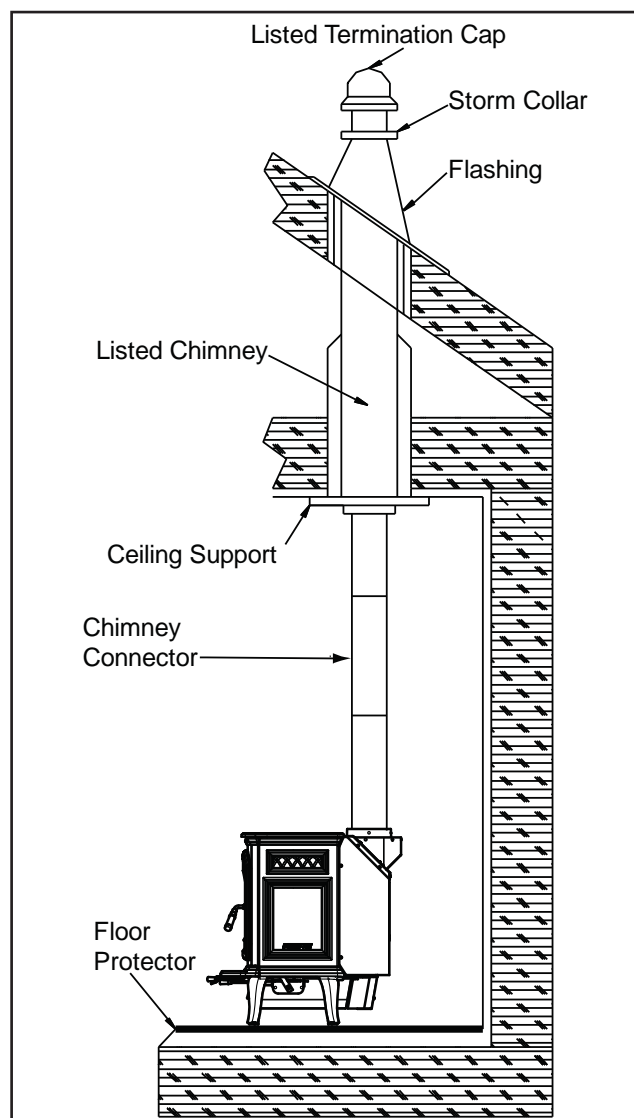

Figure 11.2 - Prefabricated Interior Chimney

# Explorer I

## Thimble

Site constructed for masonry chimney installation:

### Components

- A minimum length of 12 inches [305mm] (longer for thicker walls) of solid insulated factory-built chimney length constructed to UL 103 Type HT 6 inch (152mm) inside diameter. Chimney needs to extend a minimum of 2 inches (51mm) from the interior wall and a minimum of 1 inch (25mm) from the exterior wall.
- Wall spacer, trim collar and wall band to fit solid pack chimney selected.
- Minimum 8 inch (203mm) diameter clay liner section (if not already present in chimney) and refractory mortar.
- When jurisdiction requires install approved chimney liner in masonry chimney.

### Air Clearances

- Masonry chimney clearance must meet NFPA 211 minimum requirement of 2 inches (51mm) to sheet metal supports and combustibles.
- Minimum of 1 inch (25mm) clearance around the chimney connector.
- Top of wall opening is a minimum of 13-1/2 inches (343mm) from ceiling or 4-1/2 inches (114mm) below minimum clearance specified by chimney connector manufacturer. NFPA 211 minimum vertical clearance of 18 inches (457mm) from chimney connector and ceiling or minimum recommended by chimney connector manufacturer. **Figure 12.1**

### Instructions:

1. Open inside wall at proper height for the chimney connector to entry the masonry chimney. **Figure 12.1**
2. Entry hole to masonry chimney must be lined with an 8 inch (203mm) minimum diameter clay liner, or equivalent, secured with refractory mortar.
3. Construct a 17 inch x 17 inch (432mm x 432mm) outside dimension frame from 2 x 2 framing lumber to fit into wall opening. Inside opening of frame should be no less than 14 inch x 14 inch (356mm x 356mm). **Figure 12.1**
4. Attach the wall spacer to the chimney side of the frame.
5. Nail the frame into the wall opening. The spacer should be on the chimney side.
6. Insert the section of the solid insulated chimney into the outer wall of the masonry chimney.
7. Tightly secure the length of the solid insulated chimney with the wall band to the masonry chimney.
8. Insert a section of chimney connector into the chimney. Make sure it does not protrude past the edge of the clay chimney liner inside the chimney.
9. Seal the end of the chimney connector to the clay liner with refractory mortar.
10. Install trim collar around the sold pack chimney section.

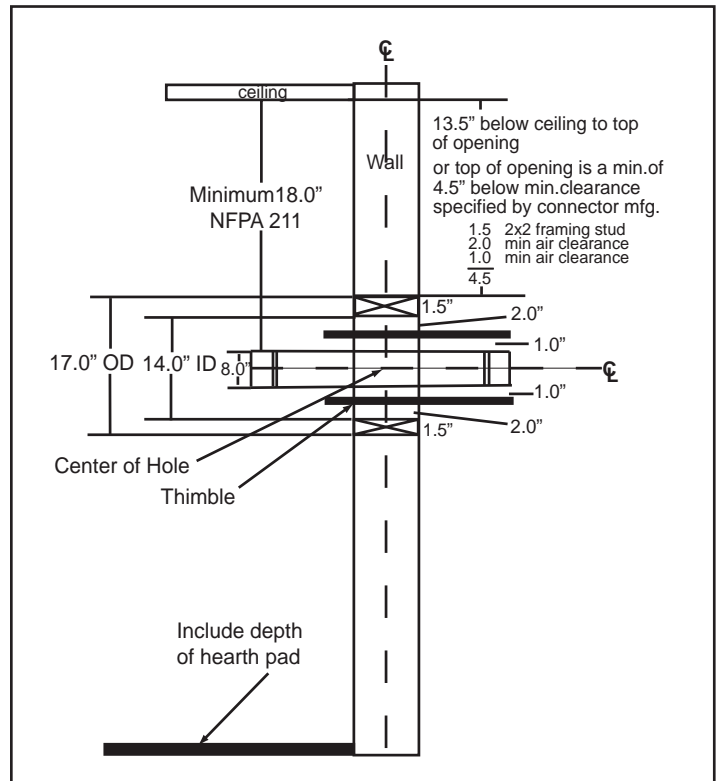

Figure 12.1

## Solid Pack Chimney with Metal Supports as a Thimble

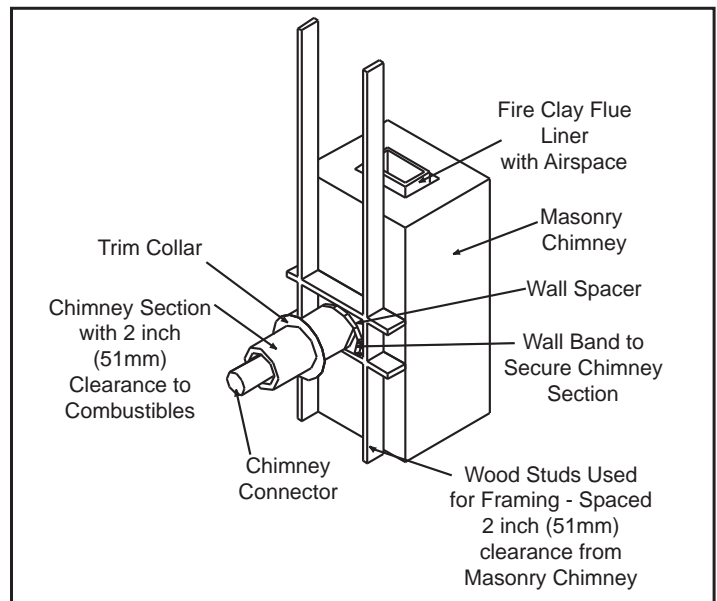

Figure 12.2

## WARNING



### Fire Risk.

Do NOT pack insulation or other combustibles between spacers.

- ALWAYS maintain specified clearances around venting and spacers.

- Install spacers as specified.

Failure to keep insulation or other material away from vent pipe may cause fire.

**Solid Pack Chimney with Metal Supports as a Thimble (Cont'd)**

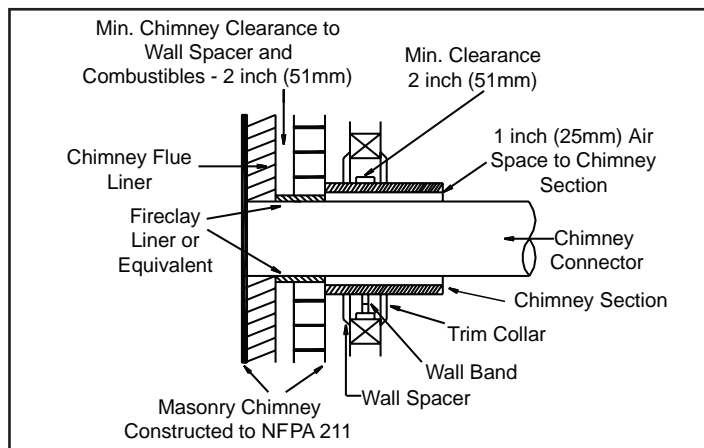

**Figure 13.1**

**Chimney Height / Rise and Run**

This product was designed for and tested on a 6 inch (152mm) chimney, 14 to 16 feet (420-480cm) high, (includes appliance height) measured from the base of the appliance. The further your stack height or diameter varies from this configuration, the greater the likelihood it may affect performance.

Chimney height may need to be increased by 2 - 3% per each 1000 feet above sea level. It is not recommended to use offsets or elbows at altitudes above 4000 feet above sea level or when there are other factors that affect flue draft.

**WARNING**

**Fire Risk.**  
 Inspection of Chimney:

- Chimney must be in good condition.
- Meets minimum standard of NFPA 211
- Factory-built chimney must be 6 inch (152mm) UL103 HT.

**WARNING**

**Asphyxiation Risk.**

- DO NOT CONNECT THIS Appliance TO A CHIMNEY FLUE SERVICING ANOTHER APPLIANCE.**
- DO NOT CONNECT TO ANY AIR DISTRIBUTION DUCT OR SYSTEM.**

May allow flue gases to enter the house.

**WARNING**

Improper installation, adjustment, alteration, service or maintenance can cause injury or property damage. Refer to the owner's information manual provided with this appliance. For assistance or additional information consult a qualified installer, service agency or your dealer.

**C. Installing Chimney Components**

**Chimney Connector**

Single wall connector or appliance pipe.

This must be at least 24 gauge mild steel or 26 gauge blue steel. The sections must be attached to the appliance and to each other with the crimped (male) end pointing toward the appliance. All joints, including the connection at the flue collar, should be secured with 3 sheet metal screws. Make sure to follow the minimum clearances to combustibles. Where passage through the wall, or partition of combustible construction is desired in Canada, the installation shall conform to CAN/CSA-B365.

Factory-built listed chimney connector (vented).

A listed connector (vented) must be used when installing this appliance in a mobile home. The listed connectors must conform to each other to ensure a proper fit and seal.

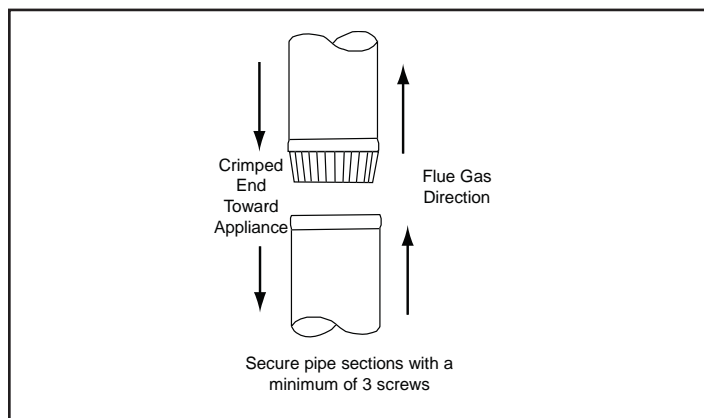

**Figure 13.2 Chimney Connector (Appliance Pipe)**

**WARNING**

**Fire Risk.**  
 Follow Chimney Connector Manufacturer's Instructions for Proper Installation.  
**ONLY use connector:**

- Within the room, between appliance and ceiling or wall.

Connector shall NOT pass through:

- Attic or roof space
- Closet or similar concealed space
- Floor or ceiling

Maintain minimum clearances to combustibles

# 5 Appliance Set-Up

## A. Hearth Protection Requirements

**FLOOR PROTECTION:** Floor protector must be non-combustible material, extending beneath heater and to the front, sides and rear as indicated. The floor must be non-combustible or otherwise adequately protected from radiant heat given off by the appliance and from sparks and falling embers. A layer of thin brick or ceramic tile over a combustible floor is not sufficient.

It is necessary to install a Type II floor protector no less than 3/8 inch (9.5mm) thick with a minimum R value of 1.06, a minimum of 16 inches (406mm) in front of glass, and 8 inches (203mm) to both sides of the fuel loading door. Open the door and measure 8 inches (203mm) from the side edge of the opening in the face of the appliance. **\*See exception.**

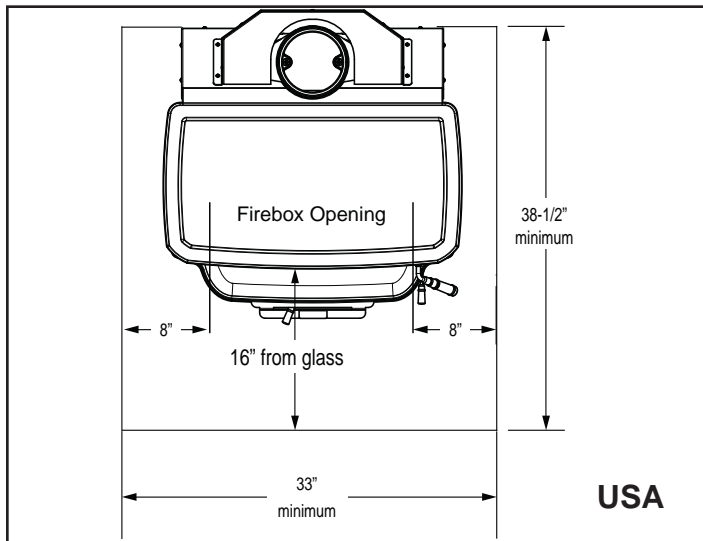

Figure 14.1

**In Canada,** similar floor protection must be provided 18 inches (457mm) in front and 8 inches (203mm) from the sides and rear of the appliance. **Figure 14.2**

**\*EXCEPTION:** Non-combustible floor protections must extend beneath the flue pipe when installed with horizontal venting and extend 2 inches (51mm) beyond each side. **See Figure 14.2**

**⚠ WARNING**

**Fire Risk.**  
Hearth pads must be installed exactly as specified. High temperatures or hot embers may ignite concealed combustibles.

Corner hearth pad dimensions with single wall pipe

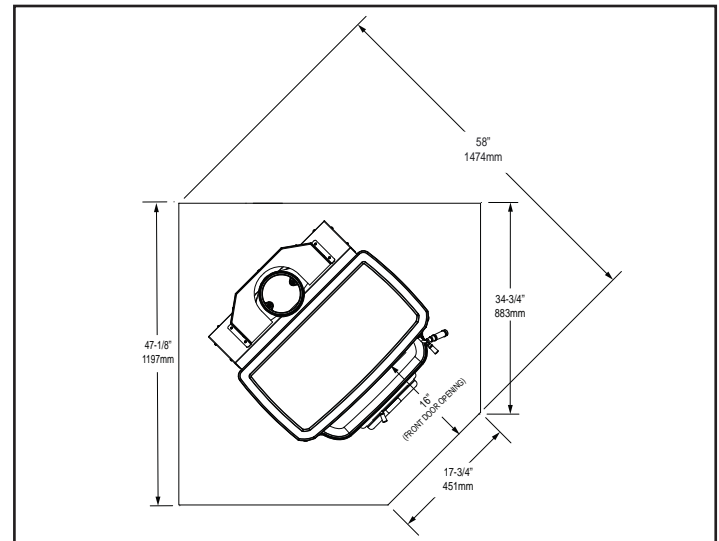

Figure 14.3

Corner hearth pad dimensions with double wall pipe

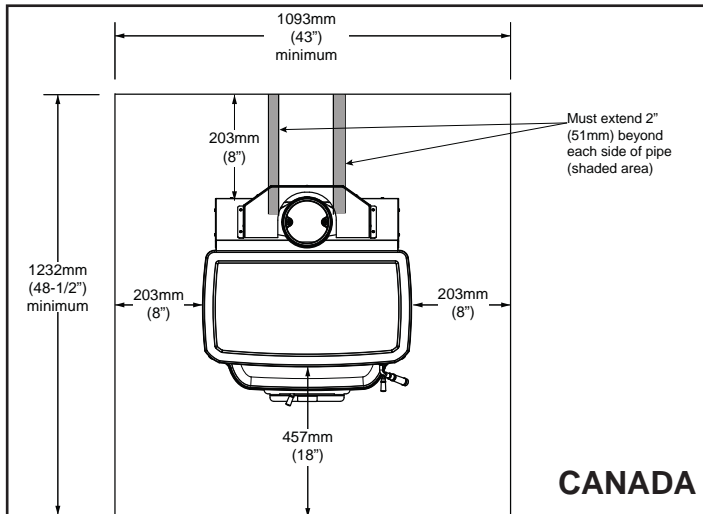

Figure 14.2

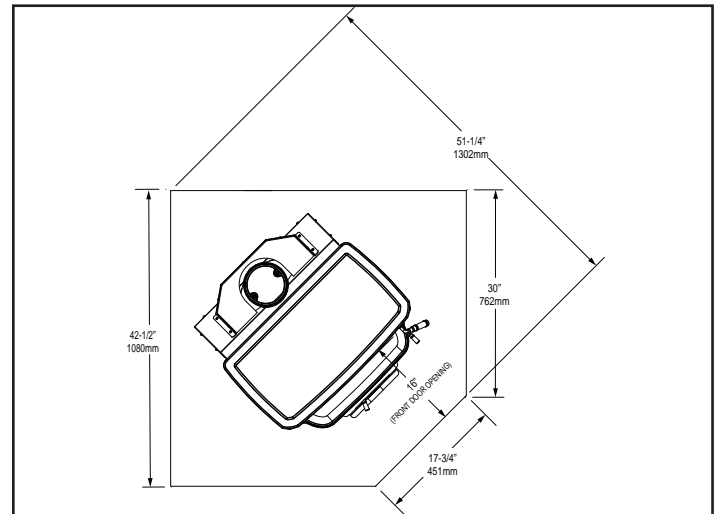

Figure 14.4



## B. Outside Air Kit Installation

A source of air (oxygen) is necessary in order for combustion to take place. Whatever combustion air is consumed by the fire must be replaced. Air is replaced via air leakage around windows and under doors. In homes that have tightly sealed doors and windows, an outside air source is needed. An optional Outside Air Kit is available.

**Included in OAK-ACC:** Termination cap, (2) wire ties, flex adapter, and fasteners

### Items Needed for Installation (not supplied)

- 4 inch flex aluminum pipe, or if using alternate material, then it shall be made from durable, non-combustible, heat resistant material up to 350°F. Cut the pipe to the required length for your installation.
  - Phillips head screw driver
  - Silicone sealant
  - Drills and saws necessary for cutting holes through the wall or flooring in your home.
1. Remove all materials from packing box.
  2. Using a #2 Phillips screw driver attach the flex adapter to the appliance using 4 screws. **Figure 15.1 & 15.2**
  3. **Floor & Rear Installation:** Cut a 4 inch (102mm) hole in outside wall or floor to accommodate outside air piping. Use 4 inch (102mm) aluminum metal flex or rigid piping to directly connect outside air to appliance intake. Use the supplied termination cap with a rodent screen. Seal between the wall (or floor) and the pipe with silicone to prevent moisture penetration.

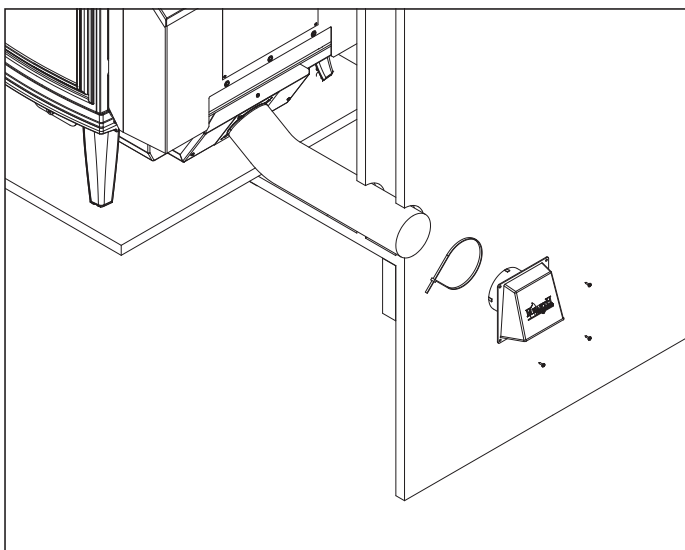

Figure 15.1 - Floor Installation

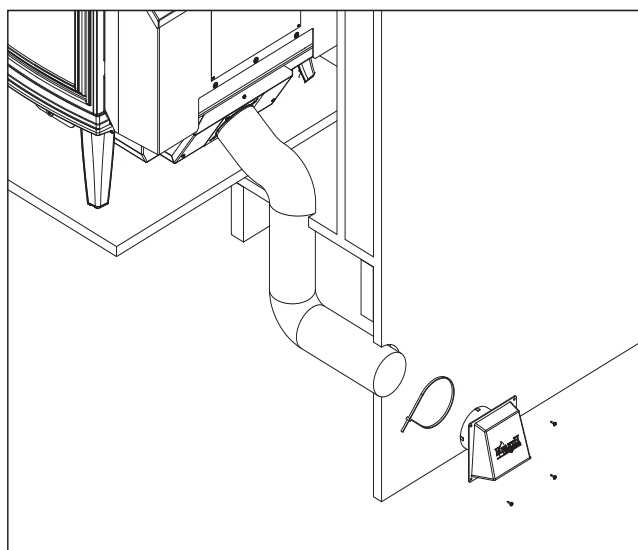

Figure 15.2 - Rear Installation

**! WARNING**

**Fire Risk. Asphyxiation Risk.**

Do not draw outside combustion air from:

- Wall, floor or ceiling cavity
- Enclosed space such as an attic or garage
- Close proximity to exhaust vents or chimneys

Fumes or odor may result

**! WARNING**

**Asphyxiation Risk.**

Outside air inlet must be located to prevent blockage from:

- Leaves
- Snow or ice
- Other debris

Block may cause combustion air starvation  
Smoke spillage may set off alarms or irritate sensitive individuals.

**! WARNING**

**Asphyxiation Risk.**

Length of outside air supply duct shall NOT exceed the length of the vertical height of the exhaust flue.

- Fire will not burn properly
- Smoke spillage occurs when door is opened due to air starvation

C. Blower (Optional)

Tools Required: #2 Phillips head screwdriver

1. Locate bolts supplied with the blower.
2. Align holes in mounting flange of blower with bolt holes in appliance. Blower should be positioned at bottom of rear outer skin as shown in **Figure 16.1**
3. Re-insert and tighten bolts, securing blower onto outer wall of appliance.
4. Place the bracket containing the snap disc and magnet under the bottom left rear corner.

See **Owner's Manual** for detailed operating instructions for the blower and snap disc.

**⚠ CAUTION**

**Shock Risk.**

- Do NOT remove grounding prong from plug.
- Route cord away from appliance.
- Do NOT route cord under or in front of appliance.
- Plug directly into properly grounded 3 prong receptacle.

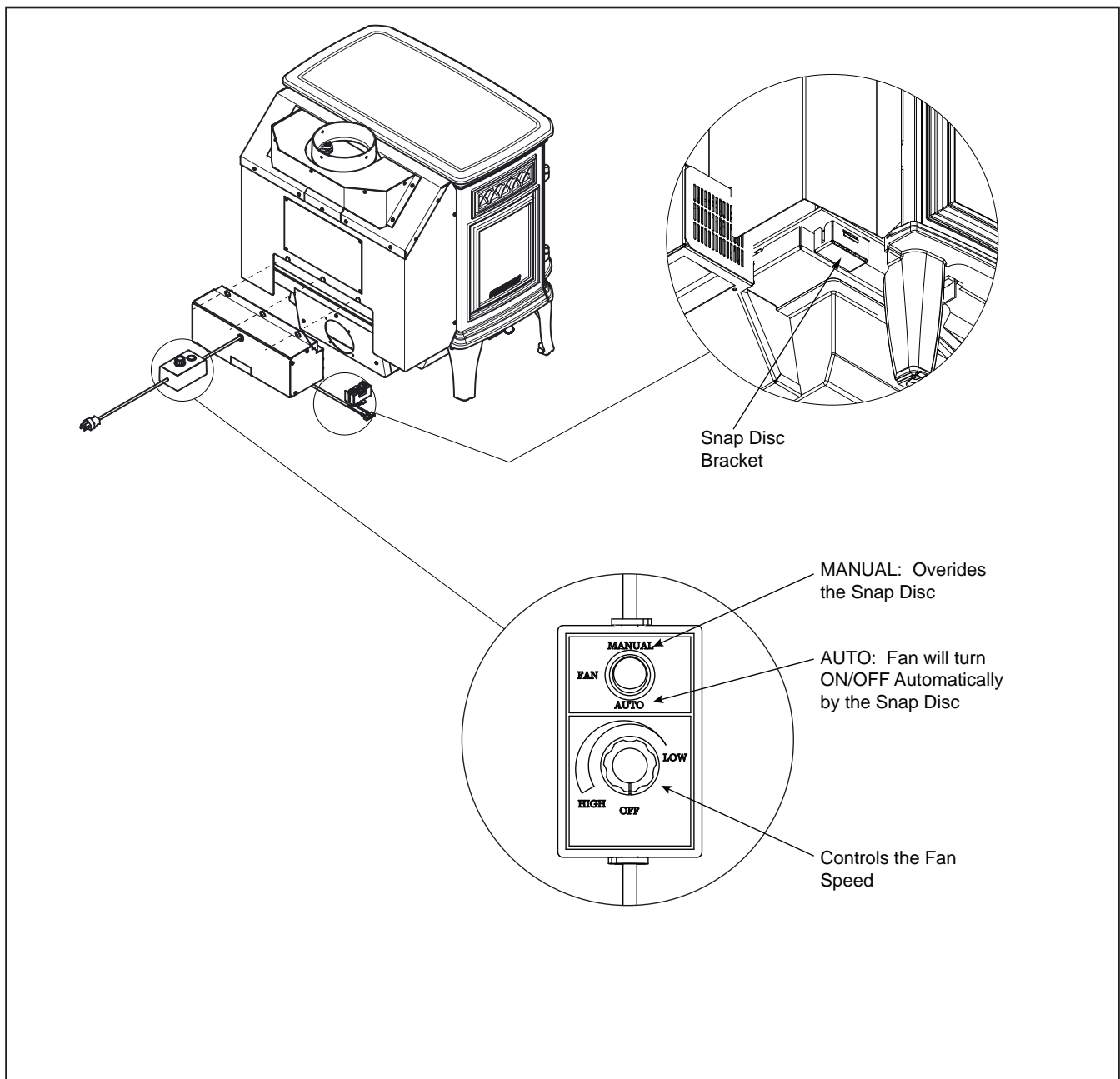



Figure 16.1

## D. Reversible Flue Collar and Horizontal Flue Heat Shield

**Tools Required:** #2 & #3 Phillips head screwdriver; 1/2" wrench

The flue collar is reversible for either a top or rear venting installation. The appliance is shipped with the flue collar in the top vent position. **(Figure 17.1)**

### Converting Collar For Rear Vent Installation

*And*

### Installing Required Horizontal Flue Shield

1. Remove flue cover from convection shroud (5 Phillips screws).
2. Remove convection shroud from appliance (4 Phillips screws).
3. Remove, rotate 180 degrees and install cast flue transition in the horizontal position.
4. Install convection shroud on to the appliance.
5. Rotate 180 degrees and install the flue cover (Use second set of provided holes).

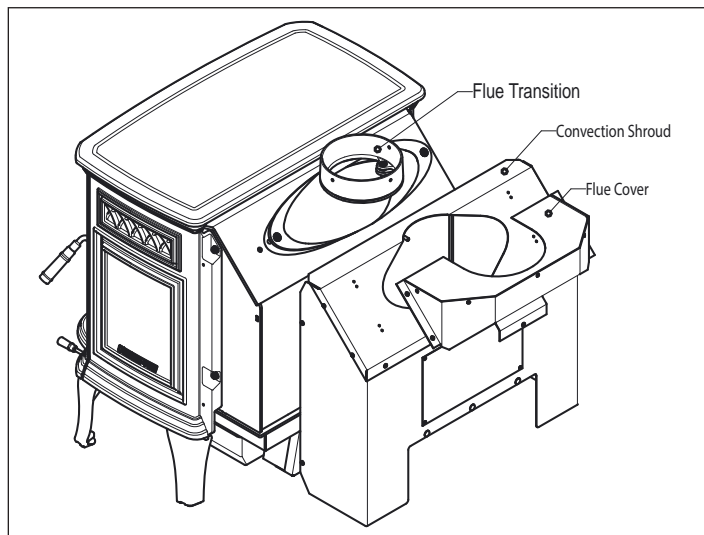

Figure 17.1

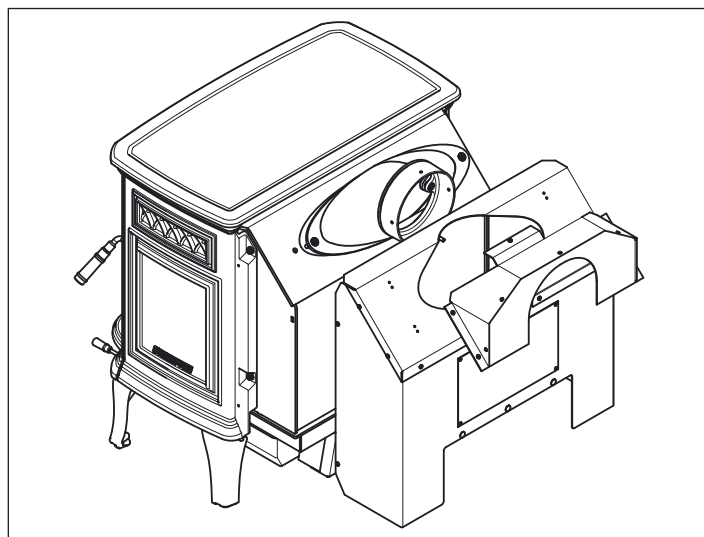

Figure 17.2

# 6 Mobile Home Installation Approved for USA Installation only!

**You must use a Quadra-Fire Outside Air Kit Part OAK-ACC for installation in a mobile home.**

1. An outside air inlet must be provided for combustion.
2. Appliance must be secured to the mobile home structure by bolting the legs to the floor.
3. Appliance must be grounded with #8 solid copper grounding wire or equivalent and terminated at each end with N.E.C. approved grounding device.
4. Appliance must be installed with an approved UL103 HT ventilated chimney connector, UL103 HT chimney, and terminal cap with spark arrestor. Never use a single wall connector (appliance pipe) in a mobile home installation. Use only double-wall connector pipe, Dura-Vent DVL, Selkirk metalbestos DS or Security DL double-wall connector or any listed double-wall connector pipe.
5. In Canada, this appliance must be connected to a 6 inch (152mm) factory-built chimney conforming to CAN/ULC-629M, STANDARD FOR FACTORY BUILT CHIMNEYS.
6. Follow the chimney and chimney connector manufacturer's instructions when installing the flue system for use in a mobile home.
7. Maintain clearance to combustibles.
8. Floor protection requirements must be followed precisely.
9. Use silicone to create an effective vapor barrier at the location where the chimney or other component penetrates to the exterior of the structure.

**NOTE:** Offsets from the vertical, not exceeding 45°, are allowed per Section 905(a) of the Uniform Mechanical Code (UMC). Offsets greater than 45° are considered horizontal and are also allowed, providing the horizontal run does not exceed 75% of the vertical height of the vent. Construction, clearance and termination must be in compliance with the UMC Table 9C. This installation must also comply with NFPA 211.

**NOTE:** Top sections of chimney must be removable to allow maximum clearance of 13.5 feet (411cm) from ground level for transportation purposes.

10. Burn wood only. Other types of fuels may generate poisonous gases (e.g., carbon monoxide).
11. If appliance burns poorly while an exhaust blower is on in home, (i.e., range hood), increase combustion air.
12. Installation shall be in accordance with the Manufacturers Home & Safety Standard (HUD) CFR 3280, Part 24.

<b>CAUTION</b>
<p>THE STRUCTURAL INTEGRITY OF THE MOBILE HOME FLOOR, WALL AND CEILING/ROOF MUST BE MAINTAINED</p> <p>Do NOT cut through:</p> <ul style="list-style-type: none"> <li>• Floor joist, wall, studs or ceiling trusses.</li> <li>• Any supporting material that would affect the structural integrity.</li> </ul>

 <b>WARNING</b>
<p><b>Asphyxiation Risk.</b></p> <p><b>NEVER INSTALL IN A SLEEPING ROOM.</b></p> <p>Consumes oxygen in the room.</p>

# 7 Accessory List

ACCESSORIES				
	Blower Assembly		BK-ACC	
	Blower Control Box W/Switch		SRV7000-194	Y
	Component Pack		7033-051	
	Magnet Round		SRV7000-140	Y
	Snap Disc Bracket Assembly		7033-036	
	Snap Disc, # 1, Convection Blower		SRV230-0470	Y
	Speed Control Only (Rheostat)		842-0370	Y
	Wire Harness (Blower)		7033-262	
	Blower, Convection	Blower Only	812-4900	Y
	Outside Air Kit, Floor & Rear		OAK-ACC	
	Outside Air Collar Assembly		7033-039	
	Outside Air Shield		33271	Y
	Firescreen		SCR-7062	
FASTENERS				
	Avk Rivnut Repair Kit - 1/4-20 & 3/8-16 Rivnut Tools		RIVNUT-REPAIR	Y
	Nut, Ser Flange Small 1/4-20	Pkg of 24	226-0130/24	Y
	Screw, Pan Head Philips 8-32 X 3/8	Pkg of 40	225-0500/40	Y
	Screw, Sheet Metal #8 X 1/2 S-Grip	Pkg of 40	12460/40	Y
	Washer, 1/4 Sae	Pkg of 24	28758/24	Y

# QUADRA-FIRE®

NOTHING BURNS LIKE A QUAD

## CONTACT INFORMATION

Hearth & Home Technologies  
1445 North Highway  
Colville, WA 99114  
Division of HNI INDUSTRIES

Please contact your Quadra-Fire dealer with any questions or concerns.  
For the number of your nearest Quadra-Fire dealer  
Log onto [www.quadrafire.com](http://www.quadrafire.com)

### CAUTION



#### DO NOT DISCARD THIS MANUAL

- Important operating and maintenance instructions included.
- Read, understand and follow these instructions for safe installation and operation.
- Leave this manual with party responsible for use and operation.

DO NOT  
DISCARD

We recommend that you record the following pertinent information for your heating appliance.

Date purchased/installed: \_\_\_\_\_

Serial Number: \_\_\_\_\_ Location on appliance: \_\_\_\_\_

Dealership purchased from: \_\_\_\_\_ Dealer phone: \_\_\_\_\_

Notes: \_\_\_\_\_

\_\_\_\_\_

\_\_\_\_\_

This product may be covered by one or more of the following patents: (United States) 5341794, 5263471, 6688302, 7216645, 7047962 or other U.S. and foreign patents pending.

# Owner's Manual

## Operation & Care

**INSTALLER:** Leave this manual with party responsible for use and operation.

**OWNER:** Retain this manual for future reference.

Contact your dealer with questions on installation, operation, or service.

# QUADRA-FIRE®

Explorer I

Model(s):

*EXPLR-I-MBK*                      *EXPLR-I-PFT*  
*EXPLR-I-PBK*                      *EXPLR-I-PMH*  
*EXPLR-I-PDB*

**NOTICE: DO NOT DISCARD THIS MANUAL**

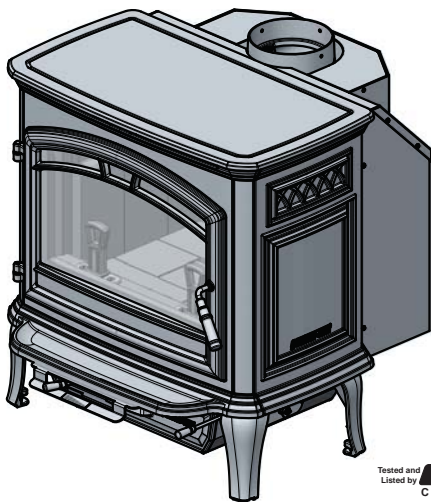

Tested and  
Listed by  Portland  
US Oregon USA  
OMNI-Test Laboratories, Inc.

### WARNING



If the information in these instructions is not followed exactly, a fire may result causing property damage, personal injury, or death.

- Do not store or use gasoline or other flammable vapors and liquids in the vicinity of this or any other appliance.
- Do not over-fire - If heater or chimney connector glows, you are over-firing. Over-firing will void your warranty.
- Comply with all minimum clearances to combustibles as specified. Failure to comply may cause house fire.

### WARNING



**HOT SURFACES!**  
Glass and other surfaces are hot during operation AND cool down.

**Hot glass will cause burns.**

- Do not touch glass until it is cooled
- NEVER allow children to touch glass
- Keep children away
- CAREFULLY SUPERVISE children in same room as appliance.
- Alert children and adults to hazards of high temperatures
- **High temperatures may ignite clothing or other flammable materials.**
- Keep clothing, furniture, draperies and other flammable materials away.

### WARNING



**Fire Risk.**  
For use with solid wood fuel only. Other fuels may over-fire and generate poisonous gases (i.e. carbon monoxide).

### NOTE

To obtain a French translation of this manual, please contact your dealer or visit [www.quadrafire.com](http://www.quadrafire.com)

Pour obtenir une traduction française de ce manuel, s'il vous plaît contacter votre revendeur ou visitez [www.quadrafire.com](http://www.quadrafire.com)

myhht  
FACTORY  
training

Installation and service of this appliance should be performed by qualified personnel. Hearth & Home Technologies recommends HHT Factory Trained or NFI certified professionals.





# Congratulations



and Welcome to the Quadra-Fire Family!

## A. Congratulations

Hearth & Home Technologies welcomes you to our tradition of excellence! In choosing a Quadra-Fire appliance, you have our assurance of commitment to quality, durability, and performance.

This commitment begins with our research of the market, including 'Voice of the Customer' contacts, ensuring we make products that will satisfy your needs. Our Research and Development facility then employs the world's most

advanced technology to achieve the optimum operation of our appliances, inserts and fireplaces. And yet we are old-fashioned when it comes to craftsmanship. Each appliance is meticulously fabricated and gold and nickel surfaces are hand-finished for lasting beauty and enjoyment. Our pledge to quality is completed as each model undergoes a quality control inspection.

We wish you and your family many years of enjoyment in the warmth and comfort of your hearth appliance. Thank you for choosing Quadra-Fire.

**NOTE: Clearances may only be reduced by means approved by the regulatory authority having jurisdiction**

## B. Sample of Serial Number / Safety Label

LOCATION: Back of appliance

**EXPLORER I WOOD STOVE**

TESTED TO TESTE A: NOTHING BURNS LIKE A QUADRA-FIRE

REPORT: 001VSD091S

VENTILATION SPECIFICATIONS:

**SINGLE WALL PIPE:** Six inch (152mm) diameter, minimum 24 MSG black or blue steel connector pipe, with a listed factory-built UL103HT\* Class "A" chimney, suitable for use with solid fuels, or a masonry chimney, and the referenced clearances.

**DOUBLE WALL PIPE:** Six inch (152mm) diameter, listed double wall air pipe with listed factory-built UL103HT\* Class "A" chimney, or a masonry chimney and the referenced clearances.

**Factory-built chimneys:** Use double wall pipe by Dura-Vent DVL, Selkir Metalbestos DS or Security DL double wall connector pipe. Must be equipped with a spark arrester.

**MINIMUM CLEARANCES TO COMBUSTIBLES:** In inches & (millimeters) NOTE: "A" - "I" Dimensions are to inside diameter of the flue collar.

INSTALLATION	A	B	C	D	E	F	G	H	I	J
<b>SINGLE WALL PIPE</b>	17 (432)	12.5 (318)	24 (610)	11 (280)	18 (458)	53.5 (1359)	NA	8 (204)	53.5 (1359)	NA
<b>DOUBLE WALL PIPE</b>	13.5 (343)	9 (227)	23 (585)	10 (254)	15 (381)	37.5 (953)	NA	8 (204)	53.5 (1359)	NA

**INSTALLATION:** 90° ELBOW OFF TOP OF STOVE TO BACK OF CHIMNEY

**INSTALLATION:** 90° DU COUREUR AU DESSUS DE LA PARTIE ARRIERE DU POELE

**SINGLE WALL PIPE** 17 (432) | 12.5 (318) | 24 (610) | 11 (280) | 18 (458) | 53.5 (1359) | 18 (458) | NA | NA | CONDUIT DU MUR SIMPLE || **DOUBLE WALL PIPE** | 13.5 (343) | 9 (227) | 23 (585) | 10 (254) | 15 (381) | 37.5 (953) | 15 (381) | NA | NA | CONDUIT DU MUR DOUBLE |

**INSTALLATION: HORIZONTAL WALL**

**INSTALLATION: HORIZONTAL SINGLE & DOUBLE WALL PIPE**

<b>SINGLE WALL PIPE</b>	24 (610)	11 (280)	NA	53.5 (1359)	8 (204)	53.5 (1359)	CONDUIT DU MUR SIMPLE
<b>DOUBLE WALL PIPE</b>	24 (610)	11 (280)	NA	53.5 (1359)	8 (204)	53.5 (1359)	CONDUIT DU MUR DOUBLE

**INSTALLATION:** 90° OFF TOP UP & OUT CEILING CLEARANCE

**INSTALLATION:** HORIZONTAL THRU WALL

Serial No.

Mfg. Date

Model Name

Test Lab & Report No.

**FLOOR PROTECTION:** It is necessary to install a Type II floor protector no less than 3/8 inch (9.5mm) thick with a minimum R value of 1.06, a minimum of 18 inches (460mm) in front of glass, and 8 inches (203mm) to both sides of the fuel loading door. Open the door and measure 8 inches (203mm) from the side edge of the opening in the face of the appliance.

**PROTECTION DU PLANCHER:** Il est nécessaire d'installer un plancher de protection de Type II au moins de 3/8 de pouce (9.5mm) d'épaisseur avec une valeur minimale de R de 1.06, un minimum de 18 pouces (460mm) à l'avant de la vitre, et 8 pouces (203mm) pour les deux côtés de la porte de chargement du combustible. Ouvrez la porte et mesurez 8 pouces (203mm) de la bordure latérale de l'ouverture dans la face de l'appareil.

**BACKWALL/SIDEWALL INSTALLATION:** The maximum depth of alcove shall be no more than 48 inches (1219mm) with a minimum height of 84 inches (2134mm) from floor to bottom of ceiling, and the maximum depth of alcove shall be no more than 48 inches (1219mm) with a minimum height of 84 inches (2134mm) from floor to bottom of ceiling, and the maximum depth of alcove shall be no more than 48 inches (1219mm) with a minimum height of 84 inches (2134mm) from floor to bottom of ceiling.

**INSTALLATION ALCOVE:** Le maximum de profondeur de l'alcove ne doit pas être de plus de 48 pouces (1219mm) avec une hauteur minimale de 84 pouces (2134mm) de la distance entre du plancher et du plafond inférieur, et des espaces de 84 pouces (2134mm) de la distance entre du plancher et du plafond supérieur.

**90° OFF TOP UP & OUT CEILING CLEARANCE:** The minimum clearance from the top of the chimney to the ceiling shall be no less than 18 inches (457mm) for a chimney with a maximum height of 18 inches (457mm) and no less than 24 inches (610mm) for a chimney with a maximum height of 24 inches (610mm) or more.

**INSTALLATION:** 90° OFF TOP UP & OUT CEILING CLEARANCE

**HORIZONTAL THRU WALL:** The minimum clearance from the side of the chimney to the wall shall be no less than 12 inches (305mm) for a chimney with a maximum height of 12 inches (305mm) and no less than 18 inches (457mm) for a chimney with a maximum height of 18 inches (457mm) or more.

**INSTALLATION:** HORIZONTAL THRU WALL

**Safety Alert Key:**

- **DANGER!** Indicates a hazardous situation which, if not avoided will result in death or serious injury.
- **WARNING!** Indicates a hazardous situation which, if not avoided could result in death or serious injury.
- **CAUTION!** Indicates a hazardous situation which, if not avoided, could result in minor or moderate injury.
- **NOTICE:** Indicates practices which may cause damage to the appliance or to property.

**TABLE OF CONTENTS**

<p>A. Congratulations..... 2</p> <p>B. Sample of Serial Number / Safety Label..... 2</p> <p>C. Warranty Policy..... 4</p> <p>D. Quick Start Guide ..... 6</p> <p><b>1 Listing and Code Approvals.....7</b></p> <p>A. Appliance Certification..... 7</p> <p>B. BTU &amp; Efficiency Specifications..... 7</p> <p>C. Mobile Home Approved (USA ONLY) ..... 7</p> <p>D. Glass Specifications ..... 7</p> <p><b>2 Operating Instructions.....8</b></p> <p>A. Over-Firing Your Appliance..... 8</p> <p>B. Wood Selection &amp; Storage..... 8</p> <p>C. Burning Process ..... 8</p> <p>D. Automatic Combustion Control (ACC)..... 9</p> <p>E. Air Controls..... 9</p> <p>F. Burn Rates and Operating Efficiency..... 10</p> <p>G. Building A Fire..... 10</p> <p>H. Correct Baffle &amp; Blanket Placement ..... 11</p> <p>I. Blower Operating Instructions..... 12</p> <p>J. Opacity (Smoke)..... 12</p> <p>K. Negative Pressure ..... 13</p> <p>L. Frequently Asked Questions..... 13</p>	<p><b>3 Maintenance and Service.....14</b></p> <p>A. Quick Reference Maintenance Guide.....14</p> <p>B. Creosote (Chimney) Cleaning .....15</p> <p>C. Ash Removal System (ARS) Operating and Cleaning.....15</p> <p>D. Disposal of Ashes .....16</p> <p>E. Glass Cleaning .....16</p> <p><b>4 Troubleshooting Guide.....17</b></p> <p><b>5 Service Part Replacement.....18</b></p> <p>A. Glass Replacement .....18</p> <p>B. Firebrick Replacement .....18</p> <p>C. Snap Disc Replacement .....19</p> <p>D. Door Handle Assembly.....19</p> <p>E. Baffle Removal .....19</p> <p>F. Tube Channel Assembly Replacement .....20</p> <p><b>6 Reference Materials.....21</b></p> <p>A. Service &amp; Maintenance Log.....21</p> <p>B. Service Parts &amp; Accessories.....22</p> <p>C. Home Owner Notes .....27</p>
--	---

C. Warranty Policy

**Hearth & Home Technologies  
LIMITED LIFETIME WARRANTY**

Hearth & Home Technologies, on behalf of its hearth brands (“HHT”), extends the following warranty for HHT gas, wood, pellet, coal and electric hearth appliances that are purchased from an HHT authorized dealer.

**WARRANTY COVERAGE:**

HHT warrants to the original owner of the HHT appliance at the site of installation, and to any transferee taking ownership of the appliance at the site of installation within two years following the date of original purchase, that the HHT appliance will be free from defects in materials and workmanship at the time of manufacture. After installation, if covered components manufactured by HHT are found to be defective in materials or workmanship during the applicable warranty period, HHT will, at its option, repair or replace the covered components. HHT, at its own discretion, may fully discharge all of its obligations under such warranties by replacing the product itself or refunding the verified purchase price of the product itself. The maximum amount recoverable under this warranty is limited to the purchase price of the product. This warranty is subject to conditions, exclusions and limitations as described below.

**WARRANTY PERIOD:**

Warranty coverage begins on the date of original purchase. In the case of new home construction, warranty coverage begins on the date of first occupancy of the dwelling or six months after the sale of the product by an independent, authorized HHT dealer/ distributor, whichever occurs earlier. The warranty shall commence no later than 24 months following the date of product shipment from HHT, regardless of the installation or occupancy date. The warranty period for parts and labor for covered components is produced in the following table.

The term “Limited Lifetime” in the table below is defined as: 20 years from the beginning date of warranty coverage for gas appliances, and 10 years from the beginning date of warranty coverage for wood, pellet, and coal appliances. These time periods reflect the minimum expected useful lives of the designated components under normal operating conditions.

Warranty Period		HHT Manufactured Appliances and Venting							Components Covered
Parts	Labor	Gas	Wood	Pellet	EPA Wood	Coal	Electric	Venting	
1 Year		X	X	X	X	X	X	X	All parts and material except as covered by Conditions, Exclusions, and Limitations listed
2 years				X	X	X			Igniters, electronic components, and glass
		X	X	X	X	X			Factory-installed blowers
			X						
3 years				X					Ignition Modules
5 years				X	X				Firepots and burnpots
1 year				X	X				Castings and baffles
7 years	3 years		X	X	X				Manifold tubes, HHT chimney and termination
10 years	1 year	X							Burners, logs and refractory
Limited Lifetime	3 years	X	X	X	X	X			Firebox and heat exchanger
90 Days		X	X	X	X	X	X	X	All replacement parts beyond warranty period

See conditions, exclusions, and limitations on next page.

**WARRANTY CONDITIONS:**

- This warranty only covers HHT appliances that are purchased through an HHT authorized dealer or distributor. A list of HHT authorized dealers is available on the HHT branded websites.
- This warranty is only valid while the HHT appliance remains at the site of original installation.
- This warranty is only valid in the country in which the HHT authorized dealer or distributor that sold the appliance resides.
- Contact your installing dealer for warranty service. If the installing dealer is unable to provide necessary parts, contact the nearest HHT authorized dealer or supplier. Additional service fees may apply if you are seeking warranty service from a dealer other than the dealer from whom you originally purchased the product.
- Check with your dealer in advance for any costs to you when arranging a warranty call. Travel and shipping charges for parts are not covered by this warranty.

**WARRANTY EXCLUSIONS:**

This warranty does not cover the following:

- Changes in surface finishes as a result of normal use. As a heating appliance, some changes in color of interior and exterior surface finishes may occur. This is not a flaw and is not covered under warranty.
- Damage to printed, plated, or enameled surfaces caused by fingerprints, accidents, misuse, scratches, melted items, or other external sources and residues left on the plated surfaces from the use of abrasive cleaners or polishes.
- Repair or replacement of parts that are subject to normal wear and tear during the warranty period. These parts include: paint, wood, pellet and coal gaskets, firebricks, grates, flame guides, batteries and the discoloration of glass.
- Expansion, contraction, or movement of certain parts causing noise. These conditions are normal and complaints related to this noise are not covered by this warranty.
- Damages resulting from: (1) failure to install, operate, or maintain the appliance in accordance with the installation instructions, operating instructions, and listing agent identification label furnished with the appliance; (2) failure to install the appliance in accordance with local building codes; (3) shipping or improper handling; (4) improper operation, abuse, misuse, continued operation with damaged, corroded or failed components, accident, or improperly/incorrectly performed repairs; (5) environmental conditions, inadequate ventilation, negative pressure, or drafting caused by tightly sealed constructions, insufficient make-up air supply, or handling devices such as exhaust fans or forced air furnaces or other such causes; (6) use of fuels other than those specified in the operating instructions; (7) installation or use of components not supplied with the appliance or any other components not expressly authorized and approved by HHT; (8) modification of the appliance not expressly authorized and approved by HHT in writing; and/or (9) interruptions or fluctuations of electrical power supply to the appliance.
- Non-HHT venting components, hearth components or other accessories used in conjunction with the appliance.
- Any part of a pre-existing fireplace system in which an insert or a decorative gas appliance is installed.
- HHT's obligation under this warranty does not extend to the appliance's capability to heat the desired space. Information is provided to assist the consumer and the dealer in selecting the proper appliance for the application. Consideration must be given to appliance location and configuration, environmental conditions, insulation and air tightness of the structure.

**This warranty is void if:**

- The appliance has been over-fired or operated in atmospheres contaminated by chlorine, fluorine, or other damaging chemicals. Over-firing can be identified by, but not limited to, warped plates or tubes, rust colored cast iron, bubbling, cracking and discoloration of steel or enamel finishes.
- The appliance is subjected to prolonged periods of dampness or condensation.
- There is any damage to the appliance or other components due to water or weather damage which is the result of, but not limited to, improper chimney or venting installation.

**LIMITATIONS OF LIABILITY:**

- The owner's exclusive remedy and HHT's sole obligation under this warranty, under any other warranty, express or implied, or in contract, tort or otherwise, shall be limited to replacement, repair, or refund, as specified above. In no event will HHT be liable for any incidental or consequential damages caused by defects in the appliance. Some states do not allow exclusions or limitation of incidental or consequential damages, so these limitations may not apply to you. This warranty gives you specific rights; you may also have other rights, which vary from state to state. EXCEPT TO THE EXTENT PROVIDED BY LAW, HHT MAKES NO EXPRESS WARRANTIES OTHER THAN THE WARRANTY SPECIFIED HEREIN. THE DURATION OF ANY IMPLIED WARRANTY IS LIMITED TO DURATION OF THE EXPRESSED WARRANTY SPECIFIED ABOVE.

D. Quick Start Guide

**Note:** These are generic drawings and may not represent your specific model.

**ITEMS NEEDED FOR FIRST FIRE:** 10 Pieces of Newspaper, 10-20 Pieces of Dry Kindling and a Few Pieces of Dry Split Wood.

**OPEN AIR CONTROLS**

see section E on page 9

1

**LOAD WOOD**

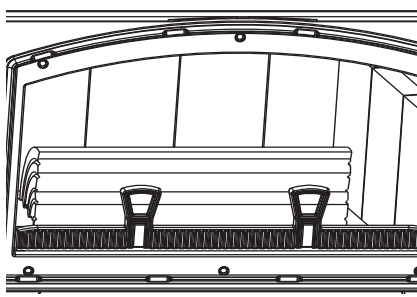

2

**ADD NEWSPAPER**

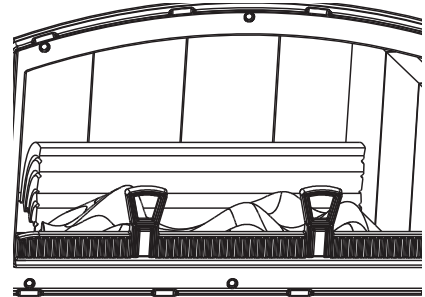

3

**ADD KINDLING**

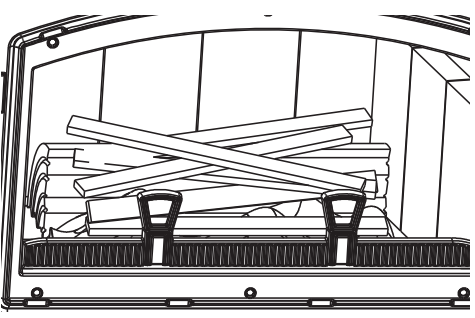

**LIGHT THE PAPER** 4

**WARNING! Risk of Fire**

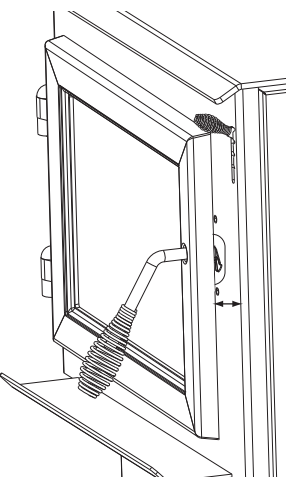

Close and securely latch the door after the fire has started, and after refueling, to prevent:

- Spillage of smoke, flame and carbon monoxide
- Spillage of sparks, coals and logs
- Over-firing

DO NOT leave the appliance unattended with the door open.

Starting a fire may not require an open door for draft. The air control should supply adequate draft.

5

**ADD MORE WOOD**

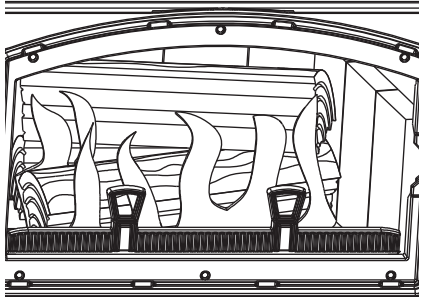

6

**ADJUST AIR CONTROL**

Set to desired heat output

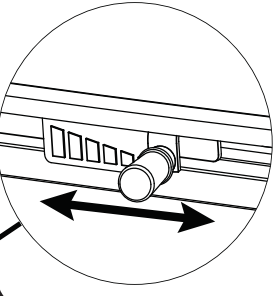

**The appliance is ready for normal operation.**



# 1 Listing and Code Approvals

## A. Appliance Certification

<b>Model:</b>	Explorer I
<b>Laboratory:</b>	OMNI Test Laboratories Inc.
<b>Report No:</b>	0061WS091S
<b>Type:</b>	Safety
<b>Standard:</b>	UL 1482-11 & 737-11; ULC S627-00

NOTE: This installation must conform with local codes. In the absence of local codes you must comply with the UL1482-07, (UM) 84-HUD and NPFA211 in the U.S.A. and the ULC S627-00 and CAN/CSA-B365 Installation Codes in Canada. **NOT APPROVED FOR MOBILE HOME INSTALLATIONS IN CANADA!**

## B. BTU & Efficiency Specifications

EPA Certification Number:	PENDING
EPA Certified Emissions:	2.2 grams per hour
*LHV Tested Efficiency:	80.2%
**HHV Tested Efficiency:	74.1%
***EPA BTU Output:	12,800 to 32,000 / hr.
****Peak BTU/Hour Output:	52,400
Vent Size:	6 inches
Firebox Size:	1.68 cubic feet
Recommended Log Length	16 inches
Fuel Orientation:	Side to Side
Fuel	Seasoned Cord Wood
*Weighted average LHV (Low Heating Value) efficiency using Douglas Fir dimensional lumber and data collected during EPA emission test. LHV assumes the moisture is already in a vapor state so there is no loss in energy to vaporize.	
**Weighted average HHV (High Heating Value) efficiency using Douglas Fir dimensional lumber and data collected during EPA emission test. HHV includes the energy required to vaporize the water in the fuel.	
***A range of BTU outputs based on EPA Default Efficiency and the burn rates from the low and high EPA tests, using Douglas Fir dimensional lumber.	
****The peak BTU out of the appliance is calculated using the maximum first hour burn rate from the High EPA Test and the BTU content of cordwood (8600) times the efficiency.	

The Quadra-Fire Explorer I meets the U.S. Environmental Protection Agency's 2015 particulate emission standards.

This appliance needs periodic inspection and repair for proper operation. It is against federal regulations to operate this appliance in a manner inconsistent with operating instructions in this manual.

## C. Mobile Home Approved (USA ONLY)

- This appliance is approved for mobile home installations in the USA when not installed in a sleeping room and when an outside combustion air inlet is provided.
- The structural integrity of the mobile home floor, ceiling, and walls must be maintained.
- The appliance must be properly grounded to the frame of the mobile home with #8 copper ground wire.
- Outside Air Kit, part OAK-ACC must be installed in a mobile home installation.

## D. Glass Specifications

This appliance is equipped with 5mm ceramic glass. Replace glass only with 5mm ceramic glass. Please contact your dealer for replacement glass.

### WARNING



#### Fire Risk.

Hearth & Home Technologies disclaims any responsibility for, and the warranty will be voided by, the following actions:

- Installation and use of any damaged appliance.
  - Modification of the appliance.
  - Installation other than as instructed by Hearth & Home Technologies.
  - Installation and/or use of any component part not approved by Hearth & Home Technologies.
  - Operating appliance without fully assembling all components.
  - Operating appliance without legs attached (if supplied with appliance).
  - Do NOT Over-fire - If appliance or chimney connector glows, you are over-firing.
- Any such action that may cause a fire hazard.

Improper installation, adjustment, alteration, service or maintenance can cause injury or property damage. For assistance or additional information, consult a qualified installer, service agency or your dealer.



NOTE: Hearth & Home Technologies, manufacturer of this appliance, reserves the right to alter its products, their specifications and/or price without notice.

Quadra-Fire is a registered trademark of Hearth & Home Technologies.

# User Guide

## 2 Operating Instructions

### A. Over-Firing Your Appliance

 <b>WARNING</b>	
	<b>Fire Risk</b>
	Do not over-fire. Over-firing may ignite creosote or will damage the appliance and chimney.
To prevent over-firing your appliance, DO NOT:	
<ul style="list-style-type: none"> <li>• Use flammable liquids</li> <li>• Overload with wood</li> <li>• Burn trash or large amounts of scrap lumber</li> <li>• Permit too much air to the fire</li> </ul>	

#### 1. Symptoms of Over-Firing

Symptoms of over-firing may include one or more of the following:

- Chimney connector or appliance glowing
- Roaring, rumbling noises
- Loud cracking or banging sounds
- Metal warping
- Chimney fire

#### 2. What To Do if Your Appliance is Over-Firing

- Immediately close the door and air controls to reduce air supply to the fire.
- If you suspect a chimney fire, call the fire department and evacuate your house.
- Contact your local chimney professional and have your appliance and appliance pipe inspected for any damage.
- Do not use your appliance until the chimney professional informs you it is safe to do so.

Hearth & Home Technologies WILL NOT warranty appliances that exhibit evidence of over-firing. Evidence of over-firing includes, but is not limited to:

- Warped air tube
- Deteriorated refractory brick retainers
- Deteriorated baffle and other interior components

### B. Wood Selection & Storage

Burn only dry seasoned wood. Store wood under cover, out of the rain and snow. Dry and well-seasoned wood will not only minimize the chance of creosote formation, but will give you the most efficient fire. Even dry wood contains at least 15% moisture by weight, and should be burned hot enough to keep the chimney hot for as long as it takes to dry the wood out - about one hour. It is a waste of energy to burn unseasoned wood of any kind.

Dead wood lying on the forest floor should be considered wet, and requires full seasoning time. Standing dead wood can be considered to be about 2/3 seasoned. To tell if wood is dry enough to burn, check the ends of the logs. If there are cracks radiating in all directions from the center, it is dry. If your wood sizzles in the fire, even though the surface is dry, it may not be fully cured.

Splitting wood before it is stored reduces drying time. Wood should be stacked so that both ends of each piece are exposed to air, since more drying occurs through the cut ends than the sides. This is true even with wood that has been split. Store wood under cover, such as in a shed, or covered with a tarp, plastic, tar paper, sheets of scrap plywood, etc., as uncovered wood can absorb water from rain or snow, delaying the seasoning process.

### C. Burning Process

In recent years there has been an increasing concern about air quality. Much of the blame for poor air quality has been placed on the burning of wood for home heating. In order to improve the situation, we at Quadra-Fire have developed cleaner-burning wood appliances that surpass the requirements for emissions established by our governing agencies. These wood appliances, like any other appliances, must be properly operated in order to insure that they perform the way they are designed to perform.

#### 1. Kindling or First Stage

It helps to know a little about the actual process of burning in order to understand what goes on inside an appliance. The first stage of burning is called the kindling stage. In this stage, the wood is heated to a temperature high enough to evaporate the moisture which is present in all wood. The wood will reach the boiling point of water (212°F) and will not get any hotter until the water is evaporated. This process takes heat from the coals and tends to cool the appliance.

Fire requires three things to burn - fuel, air and heat. So, if heat is robbed from the appliance during the drying stage, the new load of wood has reduced the chances for a good clean burn. For this reason, it is always best to burn dry, seasoned firewood. When the wood isn't dry, you must open the air controls and burn at a high burn setting for a longer time to start it burning. The heat generated from the fire should be warming your home and establishing the flue draft, not evaporating the moisture out of wet, unseasoned wood, resulting in wasted heat.

#### 2. Second Stage

The next stage of burning, the secondary stage, is the period when the wood gives off flammable gases which burn above the fuel with bright flames. During this stage of burning it is very important that the flames be maintained and not allowed to go out. This will ensure the cleanest possible fire. If the



flames tend to go out, the air control it is set too low for your burning conditions. The air control located below the ash lip is used to adjust for burn rates. This is called the Burn Rate Air Control. **Figure 9.1**

**3. Final Stage**

The final stage of burning is the charcoal stage. This occurs when the flammable gases have been mostly burned and only charcoal remains. This is a naturally clean portion of the burn. The coals burn with hot blue flames.

It is very important to reload your appliance while enough lively hot coals remain in order to provide the amount of heat needed to dry and rekindle the next load of wood. It is best to open the Burn Rate Air and Start-Up Air Controls **before reloading**. This livens up the coal bed and reduces excessive emissions (opacity/smoke). Open door slowly so that ash or smoke does not exit appliance through opening. You should also break up any large chunks and distribute the coals so that the new wood is laid on hot coals.

Air quality is important to all of us, and if we choose to use wood to heat our homes we should do so responsibly. To do this we need to learn to burn our appliances in the cleanest way possible. Doing this will allow us to continue using our wood appliances for many years to come.

**D. Automatic Combustion Control (ACC)**

Typically, when you build a fire, you open the air controls fully and monitor the fire to prevent it from going into an over-fire situation and/or burning your wood up too quickly before you shut down the air controls to the desired burn rate. With the Automatic Combustion Control (ACC) system, you do not have to continually monitor the fire. Once you set the ACC system it will control the fire for you. Follow the instructions below to learn how to operate your appliance with ease.

**E. Air Controls**

**1. Burn Rate Air Control**

This air supply enters at the lower front of the firebox, near the bottom of the glass door. This preheated air supplies the necessary fresh oxygen to mix with the unburned gases, helping to create second, third and fourth combustions. This air is regulated by the Burn Rate Air Control. There are four settings High, Medium-High, Medium-Low and Low. When the control is moved all the way to the left it is on the High setting and when moved all the way to the right it is on the Low setting. **Figure 9.1**

**2. Start-Up Air Control**

The Start-Up Air Control has two primary functions. The first function is to activate the Automatic Combustion Control system (ACC). This function is performed by pushing the control all the way back until it stops and then pulling forward to the front of the appliance until it stops. This activates the ACC system and opens the front air channel and allows air to enter the front of the appliance for approximately 25 minutes. The front air channel gradually shuts down until it is completely

closed at the end of the 25 minutes. The fire is now controlled by the air supplied by the Burn Rate Air Control. This function should be performed each time you reload the appliance. The second function is to maximize heat output. To achieve a high burn push the ACC Air Control lever in and leave in. This combined with having the main burn rate control lever pushed to the left will deliver the most amount of air needed to achieve the highest amount of heat output. **Figure 9.1**

**3. Manual Timer Over-Ride**

If you need to shut the ACC system off before it shuts itself off after 25 minutes (i.e. over-fire situation), reach down to the bottom right and pull the lever toward you. **Figure 9.2**

 <b>CAUTION</b>	
	<b>Injury Risk.</b>
	<ul style="list-style-type: none"> <li>Gloves recommended</li> </ul>

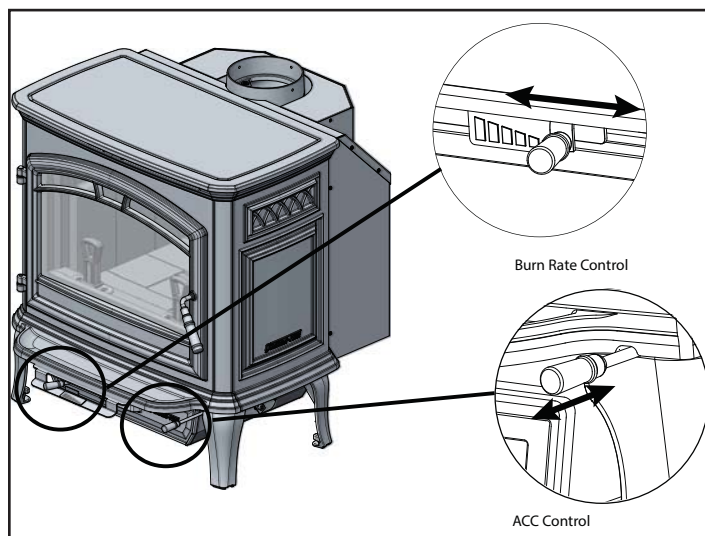

**Figure 9.1**

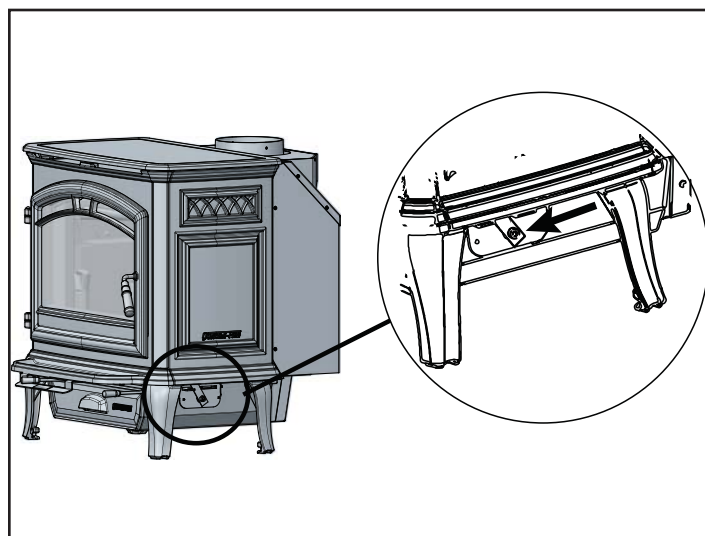

**Figure 9.2**

## F. Burn Rates and Operating Efficiency

### For maximum operating efficiency

1. This appliance has a timer system (ACC) that operates the appliance at its maximum efficiency removing any guess work for the homeowner. Follow the instructions below for each burn rate for the Start-Up Air Control and Burn Rate Air Control. **Figure 9.1**
2. Burn dry, well-seasoned wood.

### Burn Rates

Primary control is open when moved to the left...

1. Low burn setting- Burn rate control to stop (full right). Activate the ACC/start-up air.
2. Medium low burn setting- Burn rate control from stop to 1" open (left from low setting). Activate ACC/start-up air.
3. Medium high burn setting- Burn rate control to open (full left). Activate the ACC/start-up air.
4. High burn setting: Burn rate control open (full left) ACC/start-up locked open.

**Note:** 1-3 burn settings require you to activate ACC/ start-up air upon reloading. As well, the fan should remain off for the first 30 minutes. Appliance will slowly return to your desired setting of the burn rate control.

**NOTE:** Due to altitude and other circumstances this operation information is a guideline, appliances may run settings not in accordance with these guidelines to achieve same desired burn rates.

**NOTE:** Operate appliance on High Burn 45 minutes a day to help keep flue/chimney clean.

### WARNING

#### Risk of Fire.



When set on High Burn Rate and over-riding the Automatic Combustion Control system an over-fire situation can occur and may result in a chimney fire.

Over-firing will void the appliance warranty.

## G. Building A Fire

Before lighting your first fire in the appliance:

**NOTE:** The special high temperature paint that your appliance is finished with will cure as your appliance heats. You will notice an odor and perhaps see some vapor rise from the appliance surface; this is normal. We recommend that you open a window until the odor dissipates and paint is cured.

1. Confirm the baffle is correctly positioned. It should be even with the front tube and resting on all tubes. **Figure 11.1 and 11.2 on page 11.**
2. Remove all labels from glass and inside of appliance.

There are many ways to build a fire. The basic principle is to light easily-ignitable tinder or paper, which ignites the fast burning kindling, which in turn ignites the slow-burning fire-wood. Here is one method that works well:

1. Open the Burn Rate Air and Start-Up Air Controls fully.
2. Place several wads of crushed paper on the firebox floor. Heating the flue with slightly crumpled newspaper before adding kindling keeps smoke to a minimum.
3. Lay small dry sticks of kindling on top of the paper.
4. Make sure that no matches or other combustibles are in the immediate area of the appliance. Be sure the room is adequately ventilated and the flue unobstructed.
5. Light the paper in the appliance. NEVER light or rekindle fire with kerosene, gasoline, or charcoal lighter fluid; the results can be fatal.
6. Once the kindling is burning quickly, add several full-length logs 3 inches (76mm) or 4 inches (102mm) in diameter. Be careful not to smother the fire. Stack the pieces of wood carefully; near enough to keep each other hot, but far enough away from each other to allow adequate air flow between them. To maintain an efficient burn leave a 1/2" space between the highest stacked log and the tube channel assembly.
7. Set the Burn Rate Air Control and activate the start-up air control (ACC).
8. When ready to reload, It is best to fully open both the Burn Rate Air and Start-up Air Controls **before reloading**. This livens up the coal bed and reduces excessive emissions (opacity/smoke). Open door slowly so that ash or smoke does not exit appliance through opening. Large logs burn slowly, holding a fire longer. Small logs burn fast and hot, giving quick heat.
9. As long as there are hot coals, repeating steps 6 through 8 will maintain a continuous fire throughout the season.

### NOTE:

- Build fire on brick firebox floor.
- Do NOT use grates, andirons or other methods to support fuel. It will adversely affect emissions.

### WARNING



#### Fire Risk

Do NOT store wood:

- Closer than required clearances to combustibles to appliance
- Within space required for loading or ash removal.

Do NOT operate appliance:

- With appliance door open.
- With ash removal system door open.

**This wood heater has a manufacturer-set minimum low burn rate that must not be altered. It is against federal regulations to alter this setting or otherwise operate this wood heater in a manner inconsistent with operating instructions in this manual.**

**WARNING**



**Fire Risk.**

- Do NOT burn wet or green wood.
  - Store wood in dry location.
  - Stack wood so both ends are exposed to air.
- Wet, unseasoned wood can cause accumulation of creosote.

**H. Correct Baffle & Blanket Placement**

**WARNING**



**Fire Risk**

Firebox damage due to improper baffle placement is not covered by warranty. Operate the wood burning appliance with the baffle in the correct position only.

Not doing so could result in:

- Reduced efficiency
- Overheating the chimney
- Overheating the rear of the firebox
- Poor performance

Ensure correct baffle placement and replace baffle components if damaged or missing.

**CAUTION**

The baffle boards are FRAGILE. Use extreme caution when loading firewood to prevent:

- Cracking, breaking or damaging the baffle boards
- DO NOT operate the appliance without baffle boards

**CORRECT POSITION**

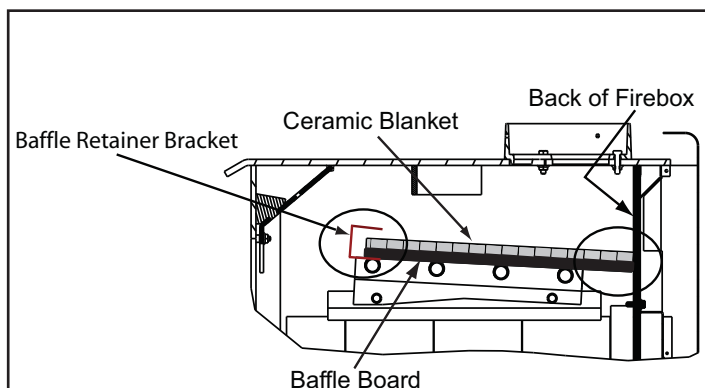

Ceramic Blanket and Baffle Board **MUST** be in contact with the back of the firebox and even with each other in the front.

Figure 11.1

**INCORRECT POSITIONS**

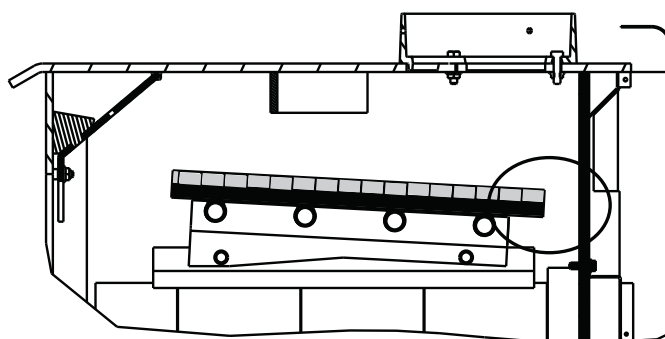

Ceramic Blanket and Baffle Board are **NOT** in contact with the back of the firebox.

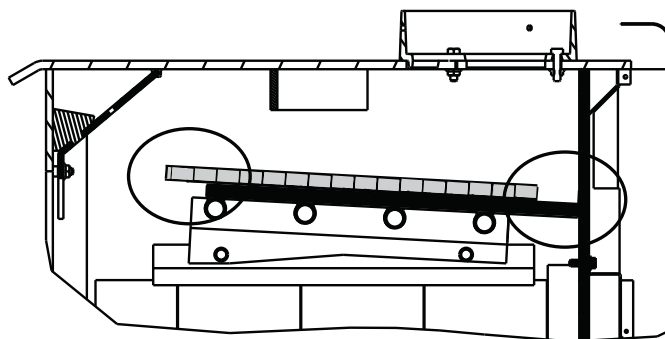

Ceramic Blanket is **NOT** in contact with the back of the firebox and **NOT** even with the Baffle Board in the front.

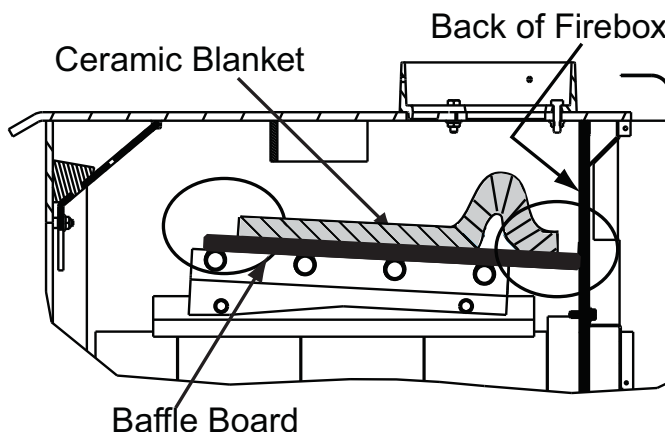

Ceramic Blanket is bunched up at the back of the firebox and **NOT** even with the Baffle Board in the front.

Figure 11.2

## I. Blower Operating Instructions

**NOTE:** If your Quadra-Fire wood appliance is equipped with an optional blower, you should follow these guidelines:

### 1. Initial (cold) start-up and all Burn Settings

The blower can be plugged in and turned on right away. The blower fan is turned on and off by a snap disc. When your appliance has reached a certain temperature the blower will turn on and when your appliance has cooled down to a certain temperature it will turn off.

2. The blower is equipped with a speed control. Adjust the fan speed by turning the speed control clockwise to "Low" or counterclockwise to "High".

3. After refueling, for maximum efficiency and lower emissions, the blower should be off for the first 30 minutes on all burn rates except for High Burn.

### 4. Snap Disc Location

If you find the blower coming on and off at undesirable temperatures, relocate the snap disc to another location in the designated zone on the back of the appliance.

**Figure 12.1** There is a manual over-ride switch to deactivate the snap disc, if necessary.

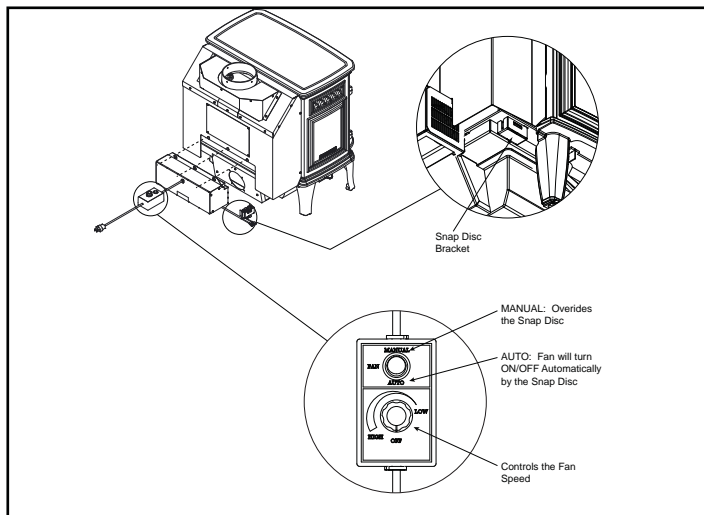

Figure 12.1

## J. Opacity (Smoke)

This is the measure of how cleanly your appliance is burning. Opacity is measured in percent; 100% opacity is when an object is totally obscured by the smoke column from a chimney, and 0% opacity means that no smoke column can be seen. As you become familiar with your appliance, you should periodically check the opacity. This will allow you to know how to burn as nearly smoke-free as possible (goal of 0% opacity).

### WARNING



#### Fire Risk.

- DO NOT BURN GARBAGE OR FLAMMABLE FLUIDS SUCH AS GASOLINE, NAPHTHA OR ENGINE OIL.
  - DO NOT burn treated wood or wood with salt (drift-wood).
  - May generate carbon monoxide if burn material other than wood.
- May result in illness or possible death.

### WARNING



#### Fire Risk.

- Keep combustible materials, gasoline and other flammable vapors and liquids clear of appliance.
- Combustible materials may ignite.
  - Do NOT store flammable materials in the appliance's vicinity.
  - DO NOT USE GASOLINE, LANTERN FUEL, KEROSENE, CHARCOAL LIGHTER FLUID OR SIMILAR LIQUIDS TO START OR "FRESHEN UP" A FIRE IN THIS HEATER.
  - Keep all such liquids well away from the appliance while it is in use.



### CAUTION

When burning your first fire, you will experience smoke and odor from the appliance resulting from the curing of paint and burning off of any oils remaining from manufacturing.

**OPEN WINDOWS DURING INITIAL BURN TO DISSIPATE SMOKE AND ODORS!**

- Odors may be irritating to sensitive individuals.
- Smoke detectors may activate.

## K. Negative Pressure

 <b>WARNING</b>	
	<p><b>Asphyxiation Risk.</b></p> <ul style="list-style-type: none"> <li>Negative pressure can cause spillage of combustion fumes, soot and carbon monoxide.</li> <li>Appliance needs to draft properly for safety.</li> </ul>

Negative pressure results from the imbalance of air available for the appliance to operate properly. It can be strongest in lower levels of the house.

Causes include:

- Exhaust fans (kitchen, bath, etc.)
- Range hoods
- Combustion air requirements for furnaces, water heaters and other combustion appliances
- Clothes dryers
- Location of return-air vents to furnace or air conditioning
- Imbalances of the HVAC air handling system
- Upper level air leaks such as:
  - Recessed lighting
  - Attic hatch
  - Duct leaks

To minimize the effects of negative air pressure:

- Install the outside air kit with the intake facing prevailing winds during the heating season
- Ensure adequate outdoor air for all combustion appliances and exhaust equipment
- Ensure furnace and air conditioning return vents are not located in the immediate vicinity of the appliance
- Avoid installing the appliance near doors, walkways or small isolated spaces
- Recessed lighting should be a “sealed can” design
- Attic hatches weather stripped or sealed
- Attic mounted duct work and air handler joints and seams taped or sealed

## L. Frequently Asked Questions

ISSUES	SOLUTIONS
Odor from appliance	When first operated, this appliance may release an odor for the first several hours. This is caused by the curing of the paint and the burning off of any oils remaining from manufacturing.
Metallic noise	Noise is caused by metal expanding and contracting as it heats up and cools down, similar to the sound produced by a furnace or heating duct. This noise does not affect the operation or longevity of the appliance.
Whirring sound	If the optional blower has been installed, the blower produces a whirring sound which increases in volume as the speed is increased.



# 3 Maintenance and Service

## A. Quick Reference Maintenance Guide

When properly maintained, your appliance will give you many years of trouble-free service. **Contact your dealer** to answer questions regarding proper operation, troubleshooting and service for your appliance. Visit [www.quadrafire.com](http://www.quadrafire.com) to locate a dealer. We recommend annual service by a qualified service technician.

**CAUTION!** Allow the appliance to completely cool down before performing any cleaning or maintenance.

Start the first inspection after the first 2 months of use, or if performance changes, and adjust your schedule accordingly. Maintenance is required for safe operation and must be performed to maintain your warranty.

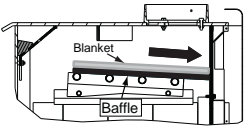
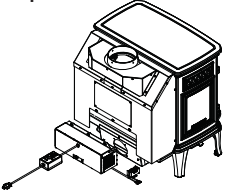
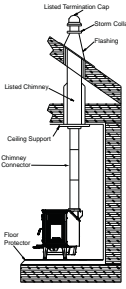
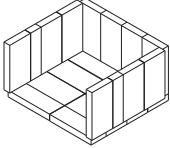
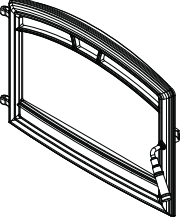
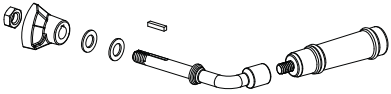
	Frequency	Task
<p><b>Baffle &amp; Blanket</b></p> 	<p>MONTHLY or After Every Cord of Wood</p>	<p>Baffle and blanket placement is critical to heat output, efficiency and overall life of the appliance. Make sure the baffle is pushed all of the way to the back of the firebox and the blanket is laying flat. Inspect baffle for cracks.</p>
<p><b>Optional Blower</b></p> 	<p>YEARLY or After Every 4 Cords of Wood</p>	<p>Vacuum the blower impellers.</p>
<p><b>Chimney System</b></p> 	<p>EVERY 2 MONTHS or After Every 4 Cords of Wood</p>	<p>The chimney and chimney cap must be inspected for soot and creosote every two months during the burn season or more frequency if chimney exceeds or is under 14-16 ft (4.3m-4.8m) measured from bottom of appliance.</p> <p>This will prevent pipe blockage, poor draft, and chimney fires.</p> <p>Always burn dry wood to help prevent cap blockage and creosote build-up.</p>
<p><b>Firebrick &amp; Ash Removal</b></p> 	<p>WEEKLY or After Every 25 Loads of Wood</p>	<p>Ashes must be cool before you can dispose of the ashes in a non-combustible container.</p> <p>Firebrick is designed to protect your firebox. After ashes are removed, inspect the firebrick and replace firebricks that are crumbling, cracked or broken.</p>
<p><b>Door &amp; Glass Assemblies</b></p> 	<p>WEEKLY or After Every 25 Loads of Wood</p>	<p>Keep door and glass gasket in good shape to maintain good burn times on a low burn setting. To test: place a dollar bill between the appliance and door and then shut the door. If you can pull the dollar out, remove one washer from door handle behind latch cam and try again. If you can still pull it out, replace the door gasket. Check the glass frame for loose screws to prevent air leakage. Check glass for cracks.</p>
<p><b>Door Handle</b></p> 	<p>WEEKLY or After Every 25 Loads of Wood</p>	<p>Check the door latch for proper adjustment. This is very important especially after the door rope has formed to the appliance face.</p> <p>Check door handle for smooth cam operation.</p>

*These are generic drawings and may not represent your model.*

## B. Creosote (Chimney) Cleaning

- **Frequency:** Every 2 months during heating season or as recommended by a certified chimney sweep; more frequently if chimney exceeds or is under 14-16 ft. (measured from bottom of appliance)
- **By:** Certified Chimney Sweep

Remove all ash from the firebox and extinguish all hot embers before disposal. Allow the appliance to cool completely. Disconnect flue pipe or remove baffle and ceramic blanket from appliance before cleaning chimney. Otherwise residue can pile up on top of the baffle and ceramic blanket and the appliance will not work properly. (See Baffle Removal on **page 19**). Close the door tightly. The creosote or soot should be removed with a brush specifically designed for the type of chimney in use. Clean out fallen ashes from the firebox.

It is also recommended that before each heating season the entire system be professionally inspected, cleaned and repaired if necessary.

**Inspection:** Inspect the system at the appliance connection and at the chimney top. Cooler surfaces tend to build creosote deposits quicker, so it is important to check the chimney from the top as well as from the bottom.

**Formation and Need For Removal:** When wood is burned slowly, it produces tar and other organic vapors which combine with expelled moisture to form creosote.

The creosote vapors condense in the relatively cool chimney flue of a newly-started or a slow-burning fire. As a result, creosote residue accumulates on the flue lining. When ignited, this creosote creates an extremely hot fire which may damage the chimney or even destroy the house.

The chimney connector and chimney should be inspected once every 2 months during the heating season to determine if a creosote or soot buildup has occurred. If creosote or soot has accumulated, it should be removed to reduce the risk of a chimney fire.

## C. Ash Removal System (ARS) Operating and Cleaning

- **Frequency:** As necessary
- **By:** Homeowner
  - a. The appliance and ashes must be completely cooled down before using the Ash Removal System. Reach down and locate the ash removal door handle under the left side of the appliance in the center. Grasp the handle with your fingers and place your thumb on the latch release (**Figure 15.1**). Press the latch release inward. Keep the latch release pressed in and lower the handle gently. Take your thumb off the release once the handle is clear of the latch and guide the handle back until it stops.
  - b. Remove cast iron cap from inside the firebox using tools supplied. Clean ash down through the ash removal system channel into the drawer below. (**Figure 15.2**)  
  
Inspect the top of the ARS door to ensure all ash has been removed. You can rapidly move the ARS latch handle up and down to help remove any ash from the door. Use a small brush to clean off the top of the door if any ash remains.
  - c. Close the door handle, you will hear a “click” when it closes. **Wear gloves to remove the drawer.** Dispose of the ashes following the directions on **the next page**.

**Be sure to replace the cap before operating the appliance.** It is recommended to leave 1/4 to 1/2 inch (6-13mm) of ash on the firebox floor to allow air to flow freely underneath wood.

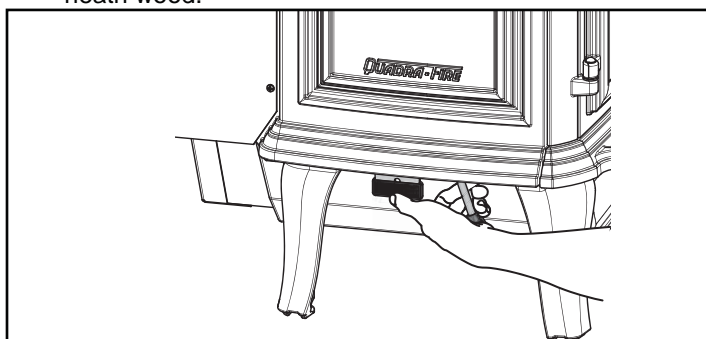





Figure 15.1

 <b>WARNING</b>	
	<b>Fire Risk.</b> Prevent creosote buildup.
	<ul style="list-style-type: none"> <li>• Inspect chimney connector and chimney once every two months during heating season.</li> </ul>
	<ul style="list-style-type: none"> <li>• Remove creosote to reduce risk of chimney fire.</li> <li>• Ignited creosote is extremely HOT.</li> </ul>

 <b>CAUTION</b>	
	<b>Injury Risk.</b>
	<ul style="list-style-type: none"> <li>• Gloves recommended</li> <li>• May have sharp edges</li> </ul>

 <b>WARNING</b>	
	<b>Fire Risk</b> <b>Injury Risk</b>
	Make sure Ash Removal System door is sealed tight against the gasket. Air leakage may cause: <ul style="list-style-type: none"> <li>• Over-fire condition.</li> <li>• Flame and/or smoke spillage.</li> <li>• Wood to burn too fast.</li> </ul>



### D. Disposal of Ashes

- **Frequency:** When ash is within 1-3/4 in. (44mm) of firebox lip
- **By:** Homeowner

Ashes should be placed in a metal container with a tight fitting lid. The closed container of ashes should be placed on a non-combustible floor or on the ground, well away from all combustible materials, pending final disposal. If the ashes are disposed of by burial in soil or otherwise locally dispersed, they should be retained in the closed container until all cinders have thoroughly cooled.



Figure 15.2

**WARNING**



**Fire Risk.  
Disposal of Ashes**

- Ashes should be placed in metal container with tight fitting lid.
- Do not place metal container on combustible surface.
- Ashes should be retained in closed container until all cinders have thoroughly cooled.

### E. Glass Cleaning

- **Frequency:** As desired
- **By:** Homeowner

Clean glass with a non-abrasive glass cleaner. Abrasive cleaners may scratch and cause glass to crack. If the deposits on the glass are not very heavy, normal glass cleaners work well. Heavier deposits may be removed by using a damp cloth dipped in wood ashes or by using a commercially available oven cleaner.

After using an oven cleaner, it is advisable to remove any residue with a glass cleaner or soap and water. Oven cleaner left on during the next firing can permanently stain the glass and damage the finish on metal surfaces.

A portion of the combustion air entering the firebox is deflected down over the inside of the door glass. This air flow “washes” the glass, helping to keep smoke from adhering to its surface.

When operated at a low burn rate, less air will be flowing over the glass and the smoky, relatively cool condition of a low fire will cause the glass to become coated.

Operating the appliance with the Burn Rate Air Control and Start-Up Air Control all the way open for 30-45 minutes should remove the built up coating.

**CAUTION**

- Do not use polishes with abrasives. It will scratch surfaces.

# 4 Troubleshooting Guide

With proper installation, operation, and maintenance your wood appliance will provide years of trouble-free service. If you do experience a problem, this troubleshooting guide will assist you or a qualified service person in the diagnosis of a problem and the corrective action to be taken.

Start Fire Problems	Possible Cause	Solution	
Can not get fire started Excessive smoke or spillage Burns too slowly Not enough heat output	Not enough kindling/paper or no kindling/paper	Use dry kindling, more paper. Arrange kindling & wood for air movement.	
	Not enough air for fire to ignite	Check for restricted termination cap	
		Check for blockage of outside air kit (if installed).	
		Check for flue blockage.	
		Pre-warm flue before starting fire (refer to Building a Fire Section).	
		Check for adequate vent height (refer to Chimney Height Section).	
	Refer to Negative Pressure section		
	Wood condition is too wet, too large	Use dry, seasoned wood (refer to Seasoned Wood Section).	
	Bed of coals not established before adding wood	Start with paper & kindling to establish bed of coals (refer to Building a Fire Section).	
Flue blockage such as birds' nests or leaves in termination cap	Have chimney inspected for creosote and cleaned by a certified chimney sweep.		
Down draft or negative pressure Competition with exhaust devices	Do not use exhaust fans during start-up (refer to Negative Pressure Section).		
Fire burns too fast	Extremely dry or soft wood	Mix in hardwood.	
		Mix in larger pieces of wood after fire is established.	
	Overdrafting	Check for correct vent height; too much vertical height creates overdrafting.	
		Check location of vent termination (refer to Chimney Termination Requirement Section).	

**Contact your dealer** for additional information regarding operation and troubleshooting.  
 Visit [www.quadrafire.com](http://www.quadrafire.com) to locate a dealer.



# 5 Service Part Replacement

## A. Glass Replacement

1. Ensure that the fire is out and the appliance is cool to the touch.
2. Protect a table or counter top with padding or towels. Protect your hands and wear gloves to prevent injury.
3. Remove the door with the broken glass by lifting the door up and off of the hinges.
4. Lay door face down on a table or counter making sure the handle hangs over the edge so the door lays flat, on a soft surface.
5. Remove the screws from each glass retainer and remove the glass. (If screws are difficult to remove, soak with penetrating oil first).
6. Center the glass with edges evenly overlapping the opening in the door, (i.e. same space top and bottom, left and right sides).
7. Replace the glass retainers. Be careful not to cross thread the screws.
8. Tighten each retainer just a few turns until each is secured. Check again for centering of glass in door frame. Continue to tighten each retainer alternately, a few turns at a time, until the glass is secure. **DO NOT OVERTIGHTEN.**
9. Replace the door on the appliance.

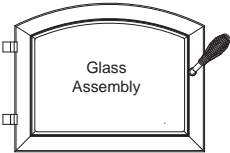
Quadra-Fire appliances are equipped with ceramic super heat-resistant glass, which can only be broken by impact or misuse. Do not slam appliance door or impact the glass. When closing door, make sure that logs do not protrude against the glass. Inspect glass regularly. If you find a crack or break, immediately put the fire out and return the door to your dealer for replacement of glass before further use.

<b>CAUTION</b>	
 <p style="text-align: center;">Glass Assembly</p>	<p>Handle glass assembly with care.</p> <p><b>When cleaning glass:</b></p> <ul style="list-style-type: none"> <li>• Avoid striking, scratching or slamming glass.</li> </ul>
<ul style="list-style-type: none"> <li>• Do NOT clean glass when hot.</li> <li>• Do NOT use abrasive cleaners.</li> <li>• Use a hard water deposit glass cleaner on white film.</li> <li>• Use commercial oven cleaner on heavier deposits.</li> <li>• Remove all residue of oven cleaner or will permanently stain glass on next firing. <b>Refer to maintenance instructions.</b></li> </ul>	

 <b>WARNING</b>	
	<p><b>Injury Risk.</b></p> <ul style="list-style-type: none"> <li>• Use only glass specified in manual.</li> <li>• <b>DO NOT REPLACE</b> with any other material.</li> </ul>

## B. Firebrick Replacement

Replace the firebrick if they become crumbly and/or if there is a 1/4 inch (6.35mm) gap between the bricks.

Inspect the firebrick after each ash removal.

The firebox is lined with high quality firebrick, which has exceptional insulating properties. There is no need to use a grate; simply build a fire on the firebox floor. Do not operate appliance without firebrick.

1. After the coals have completely cooled, remove all old brick and ash from appliance and vacuum firebox.
2. Remove new brick set from box and lay out to diagram shown.
3. Lay bottom bricks in appliance.
4. Install rear bricks on the top of the bottom bricks. Slide top of bricks under clip on back of firebox wall and push bottom of brick back.
5. Install side bricks. Slide top of brick under clips on side of firebox and push the bottom of the brick until it is flush with the side of the appliance.

### C. Snap Disc Replacement

(included with optional blower)

1. Unplug the appliance.
2. Locate the snap disc bracket assembly at the bottom left rear corner of the appliance.
3. A magnet holds the bracket to the appliance. Pull the bracket down away from the appliance to expose the snap disc.
4. Pull the snap disc and spade connectors up and out of bracket as shown in **Figure 19.1**
5. Using a Phillips head screw driver, remove the 2 screws from the snap disc and then remove the snap disc from the spade connectors. Replace with new snap disc and re-connect to spade connectors.
6. Push the snap disc and spade connectors back inside bracket. Reassemble in reverse order.

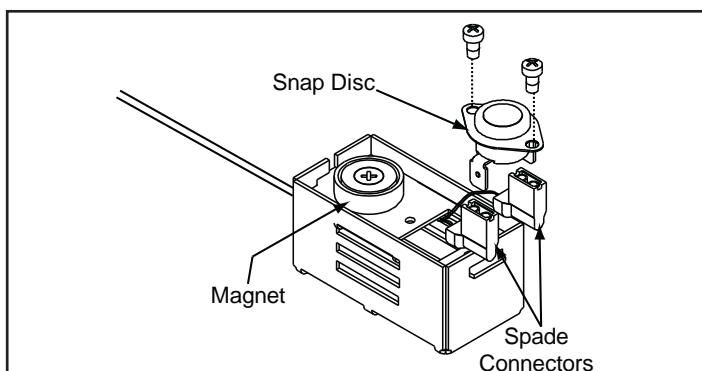

Figure 19.1

### D. Door Handle Assembly

1. Slide door handle through door.
2. Install additional washer(s) as shown in **Figure 19.2**
3. Install key in groove.
4. Align groove in latch cam with key; slide latch cam over shaft
5. Install locknut but do not overtighten, the handle needs to rotate smoothly.
6. Install fiber handle. **Figure 19.2**

**CAUTION!** Do not overtighten lock nut. The door handle needs to move smoothly.

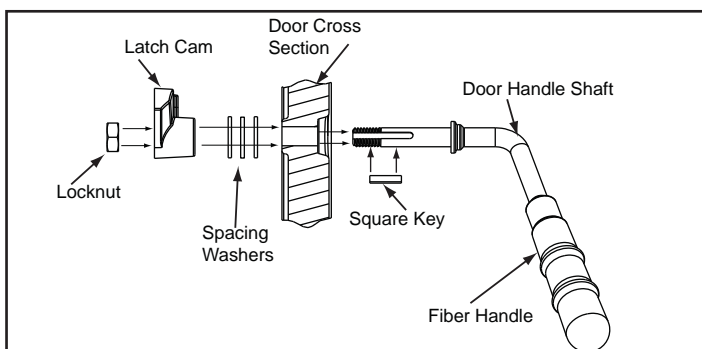

Figure 19.2

### E. Baffle Removal

1. Remove all ash from the firebox and dispose appropriately.
2. Lift baffle protection channel, board, and blanket approximately 1 inch up so it is free from the front tube.
3. Pull baffle protection channel forward to remove.
4. Lift one half of the baffle board just above the other and slide over the top so it is centered in the appliance then tilt down to remove. Slide the second half of the baffle board to the center then tilt down to remove. The baffle blanket will come out with the second board.
5. Install baffle board in the reverse manner to which it was removed.
6. Install baffle blanket. It is easier to install the blanket by folding the two sides approximately 4 inches from the end then flattening them down once seated against the rear of the firebox.
7. Install baffle protection channel. This must sit correctly on the front air tube for the appliance to work as designed.
8. **NOTE:** Check to ensure the boards and blanket are situated appropriately.

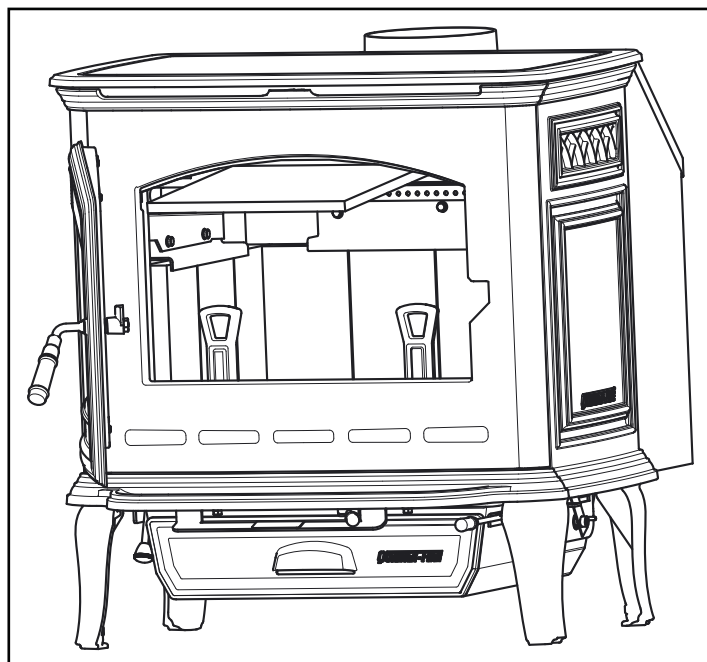

Figure 19.3

## F. Tube Channel Assembly Replacement

### Removing Tube Channel Assembly

1. Remove convection blower shroud (4 screws, 2 on each side).
  - a. Tilt shroud forward and slide up and away from appliance.
2. Remove right side casting.
  - a. CAUTION: Block up right side of appliance so the appliance is supported on the ash pan and not resting on the right side casting.
  - b. Remove the two flange nuts securing the side to the firebox.
  - c. Pull the side out and back.
3. Remove the baffle board and blanket.
4. Remove the tube channel assembly (It is recommended to soak the bolts with penetrating oil for at least 15 minutes before trying to remove them.).
  - a. Remove the two flange nuts.
  - b. Remove the two hex bolts
  - c. Remove tube channel assembly

**NOTE: Service Space**

In order to replace the tube channel assembly a clearance of 19 inches (483mm) is required on the right side of appliance in order to remove the tubes with the appliance in place.

If space is not available, the appliance will have to be disconnected from the chimney to proceed with the tube replacement.

### Replacing Tube Channel Assembly

1. Install baffle board, blanket, and tube assembly.
  - a. Insert baffle blanket
  - b. Insert tube assembly 2/3 of the way into the firebox.
  - c. Place baffle boards on top of tube assembly and situate the boards and blanket so they seat correctly
  - d. Insert tube assembly fully into the tube channel supports on the left side of the firebox.
  - e. Install baffle protection channel.
  - f. Secure two hex bolts.
  - g. Secure two flange nuts.
  - h. CAUTION: Ensure baffle board, baffle protection channel, and blanket are installed correctly.
2. Install right side casting.
  - a. Insert guide plates into the front of the firebox.
  - b. Place casting over two bolts.
  - c. Secure with two flange nuts.
3. Remove support from under ash pan.
4. Install convection blower shroud.

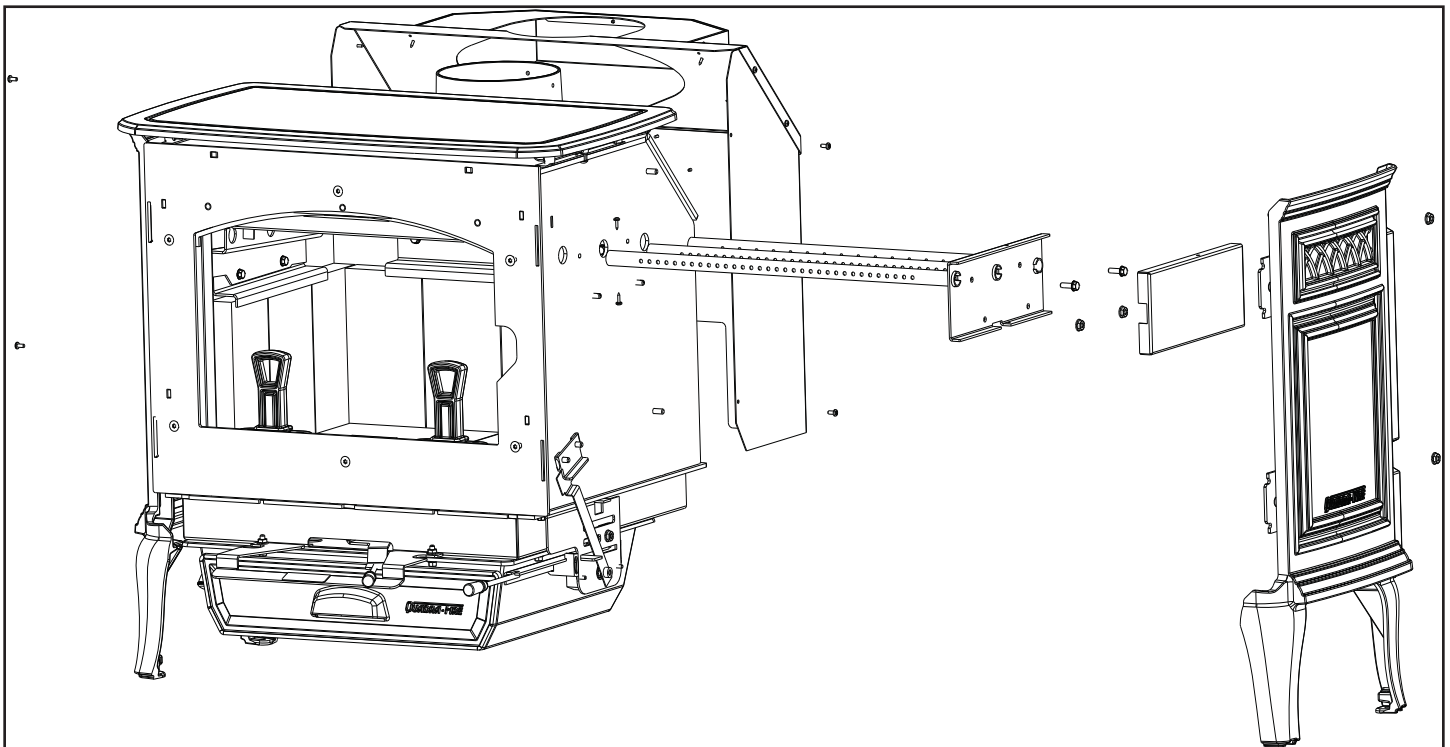
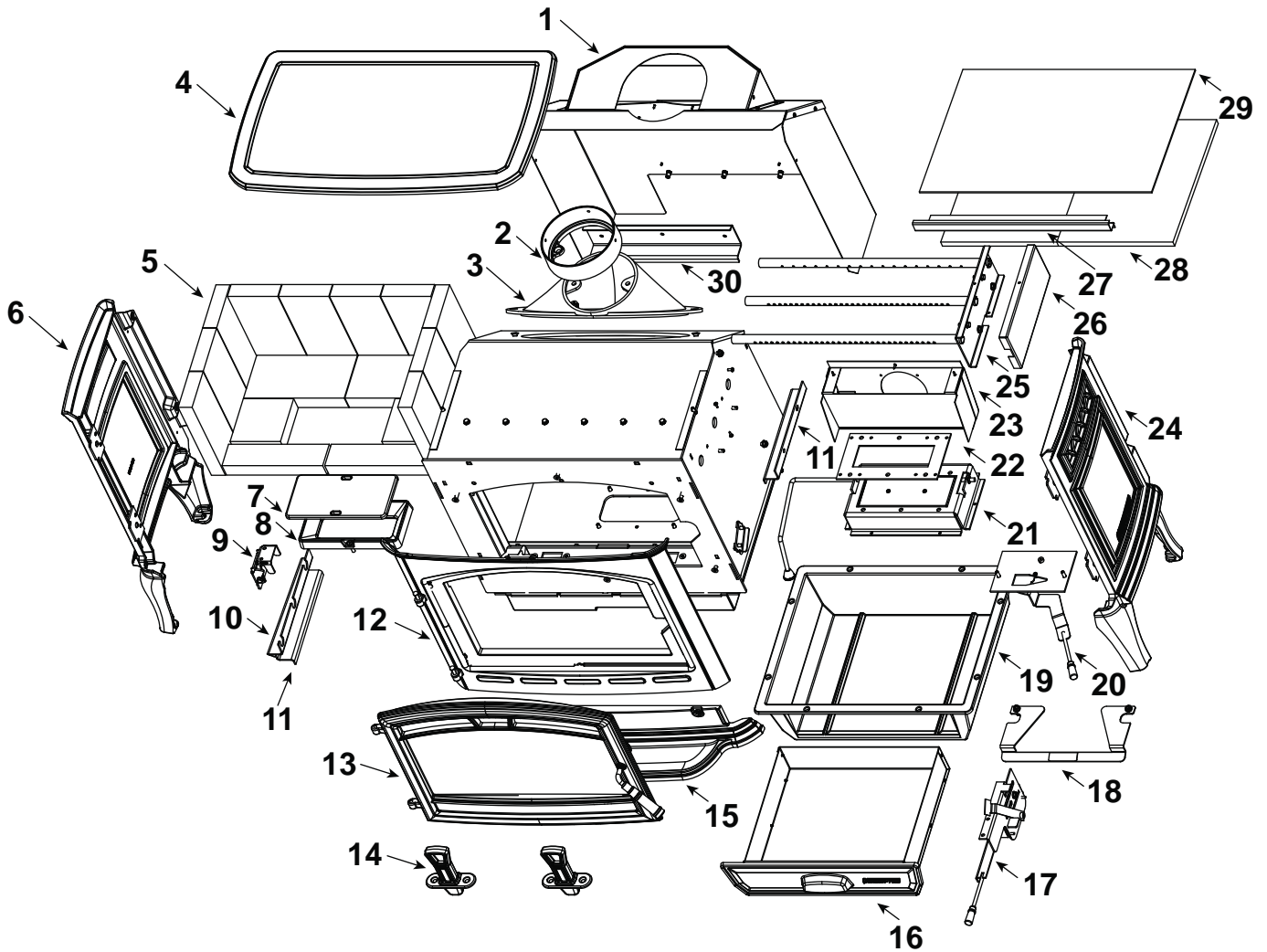

Figure 20.1



Color	SKU No.	Mfg. Dates
Matte Black	EXPLR-I-MBK	11/15-
Porcelain Black	EXPLR-I-PBK	11/15-
Porcelain Dark Blue	EXPLR-I-PDB	11/15-
Porcelain Frost	EXPLR-I-PFT	11/15-
Porcelain Mahogany	EXPLR-I-PMH	11/15-



Part number list on following page.

11/15



IMPORTANT: THIS IS DATED INFORMATION. Parts must be ordered from a dealer or distributor. **Hearth and Home Technologies does not sell directly to consumers.** Provide model number and serial number when requesting service parts from your dealer or distributor.



Stocked at Depot

ITEM	DESCRIPTION	COMMENTS	PART NUMBER
1	Rear Shroud Assembly		SRV7062-010
2	Flue Collar		SRV7061-201
3	Flue Transition Assembly		SRV29138
4	Top	Matte Black	7062-101MBK
		Porcelain Black	7062-101PBK
		Porcelain Blue	7062-101PDB
		Porcelain Frost	7062-101PFT
		Porcelain Mahogany	7062-101PMH

**#5 Brick Assembly**

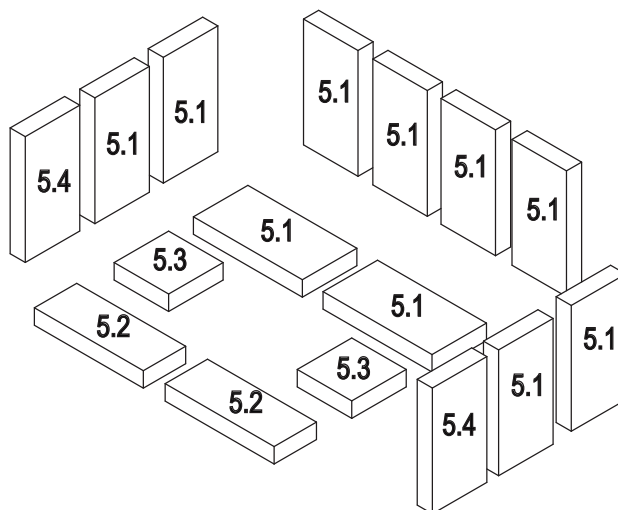

5	Brick Assembly		SRV7062-004
5.1	Brick #1, 9 X 4.5 X 1.25	Qty 10 req	
5.2	Brick #2, 9 x 2.5 x 1.25	Qty 2 req	
5.3	Brick #3, 4.5 x 4.5 x 1.25	Qty 2 req	
5.4	Brick #4, 9 X 3.75 X 1.25	Qty 2 req	
	Brick, Uncut <b>(Must specify size when ordering)</b>	Pkg of 1	832-0550
		Pkg of 6	832-3040
6	Side Left	Matte Black	7062-019MBK
		Porcelain Black	7062-019PBK
		Porcelain Blue	7062-019PDB
		Porcelain Frost	7062-019PFT
		Porcelain Mahogany	7062-019PMH
7	ARS Access Cover		SRV7038-196
8	ARS Channel		SRV7061-184
9	ARS Latch Assembly		SRV7062-034

Additional service part numbers appear on following page.

Beginning Manufacturing Date: Nov 2015  
Ending Manufacturing Date: Active

IMPORTANT: THIS IS DATED INFORMATION. Parts must be ordered from a dealer or distributor. **Hearth and Home Technologies does not sell directly to consumers.** Provide model number and serial number when requesting service parts from your dealer or distributor.



**Stocked at Depot**

ITEM	DESCRIPTION	COMMENTS	PART NUMBER	
10	Tube Rack		SRV7062-139	
11	Side Brick Retainer		SRV7062-138	
12	Front	Matte Black	7062-103MBK	
		Porcelain Black	7062-103PBK	
		Porcelain Blue	7062-103PDB	
		Porcelain Frost	7062-103PFT	
		Porcelain Mahogany	7062-103PMH	
	Gasket 1/2"		7000-811	
13	Door Assembly	Matte Black	7062-003MBK	
		Porcelain Black	7062-003PBK	
		Porcelain Blue	7062-003PDB	
		Porcelain Frost	7062-003PFT	
		Porcelain Mahogany	7062-003PMH	

### #13 Door Assembly

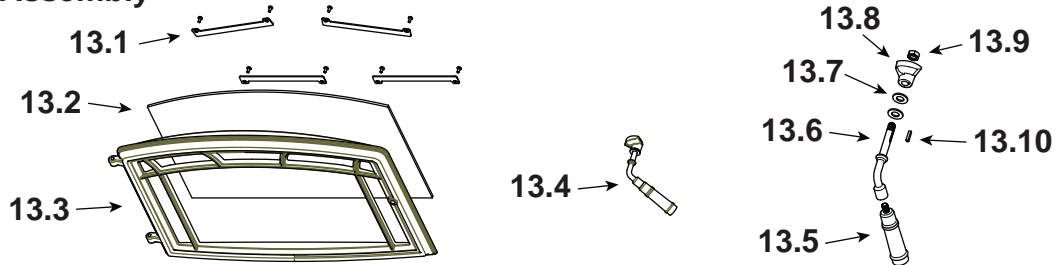

13.1	Glass Retainers		SRV7063-166	
13.2	Glass Assembly		SRV7062-013	Y
13.3	Door	Matte Black	7062-109MBK	
		Porcelain Black	7062-109PBK	
		Porcelain Blue	7062-109PDB	
		Porcelain Frost	7062-109PFT	
		Porcelain Mahogany	7062-109PMH	
13.4	Door Handle Assembly		SRV7063-014	Y
13.5	Fiber Handle		SRV7060-212	Y
13.6	Door Handle		SRV7063-137	
13.7	Washer, Sae, 3/8 (3 Ea)	Pkg of 3	832-0990	Y
13.8	Cam Latch		430-1141	
13.9	Nut, 2Wy Side Lock Jam 3	Pkg of 24	226-0100/24	Y
13.10	Key, Cam Latch		430-1151	
14	Andirons	2 Sets	SRV7061-020	

Additional service part numbers appear on following page.

IMPORTANT: THIS IS DATED INFORMATION. Parts must be ordered from a dealer or distributor. **Hearth and Home Technologies does not sell directly to consumers.** Provide model number and serial number when requesting service parts from your dealer or distributor.



**Stocked at Depot**

ITEM	DESCRIPTION	COMMENTS	PART NUMBER	
15	Ashlip	Matte Black	7062-113MBK	
		Porcelain Black	7062-113PBK	
		Porcelain Blue	7062-113PDB	
		Porcelain Frost	7062-113PFT	
		Porcelain Mahogany	7062-113PMH	
16	Ashpan		SRV7060-023	
17	Timer Assembly		SRV7062-025	
	Timer (Only) Replacement Assembly		SRV480-1940	Y
18	Burn Rate Indicator		SRV7062-174	
19	ARS Box		SRV7060-005	
20	Burn Rate Control		SRV7062-023	
21	ARS Assembly		SRV7062-035	
22	Gasket, ARS		SRV7033-296	Y
23	Outside Air Chamber		SRV7062-173	
24	Side Right	Matte Black	7062-018MBK	
		Porcelain Black	7062-018PBK	
		Porcelain Blue	7062-018PDB	
		Porcelain Frost	7062-018PFT	
		Porcelain Mahogany	7062-018PMH	
25	Tube Channel		SRV7062-017	Y
26	Tube Chanel cover		SRV7062-148	

**#27 Baffle Protection Channel**

Side view

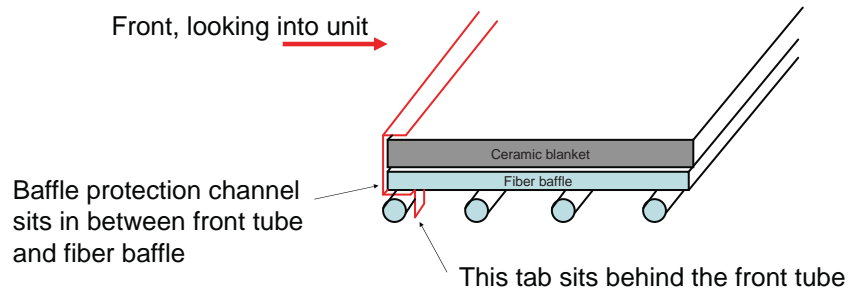

27	Baffle Protection Channel		SRV7062-149	Y
28	Baffle Board	2 pcs.	SRV7062-132	Y
29	Baffle Blanket		SRV7062-133	Y
30	Rear Brick Retainer		SRV7062-137	

Additional service part numbers appear on following page.

IMPORTANT: THIS IS DATED INFORMATION. Parts must be ordered from a dealer or distributor. **Hearth and Home Technologies does not sell directly to consumers.** Provide model number and serial number when requesting service parts from your dealer or distributor.



**Stocked  
at Depot**

ITEM	DESCRIPTION	COMMENTS	PART NUMBER	
	Component Pack (Includes Baffle Diverter and Instructions, 2 Leg Leveling Nuts & 2 Bolts, Touch-Up Paint, Owners Manual & Warranty Card)	Matte Black	SRV7062-027	
		Porcelain Black	SRV7062-028	
		Porcelain Blue	SRV7062-029	
		Porcelain Frost	SRV7062-030	
		Porcelain Mahogany	SRV7062-031	
	Leveling Assembly		7000-000	
	Paint Touch-Up	Matte Black	812-0910	
		Porcelain Black	1-00-0022	
		Porcelain Blue	1-00-0020	
		Porcelain Frost	1-00-0021	
		Porcelain Mahogany	855-1450	



# QUADRA-FIRE®

NOTHING BURNS LIKE A QUAD

## CONTACT INFORMATION

Hearth & Home Technologies  
1445 North Highway  
Colville, WA 99114  
Division of HNI INDUSTRIES

Please contact your Quadra-Fire dealer with any questions or concerns.  
For the number of your nearest Quadra-Fire dealer  
log onto [www.quadrafire.com](http://www.quadrafire.com)

### CAUTION



#### DO NOT DISCARD THIS MANUAL

- Important operating and maintenance instructions included.
- Read, understand and follow these instructions for safe installation and operation.
- Leave this manual with party responsible for use and operation.

DO NOT  
DISCARD

**We recommend that you record the following pertinent information for your heating appliance.**

Date purchased/installed: \_\_\_\_\_

Serial Number: \_\_\_\_\_ Location on appliance: \_\_\_\_\_

Dealership purchased from: \_\_\_\_\_ Dealer phone: \_\_\_\_\_

Notes: \_\_\_\_\_

This product may be covered by one or more of the following patents: (United States) 5341794, 5263471, 6688302, 7216645, 7047962 or other U.S. and foreign patents pending.

## **Section 5**

### **Test Data by Run**



# EPA Weighted Average Emissions EPA Method 28R

Client: Hearth & Home	Status: Final
Stove Model: Explorer I	Stove Type: Non-Catalytic Stove
Test Dates: September 28, 2015 - October 1, 2015	
Project Number: 0061WS091E	
Tracking Number: 2135	

	<b>Emissions (g/hr):</b>	<b>2.2</b>
<b>Weighted Averages</b>	<b>HHV Efficiency (%):</b>	<b>74.1</b>
	<b>LHV Efficiency (%):</b>	<b>80.1</b>

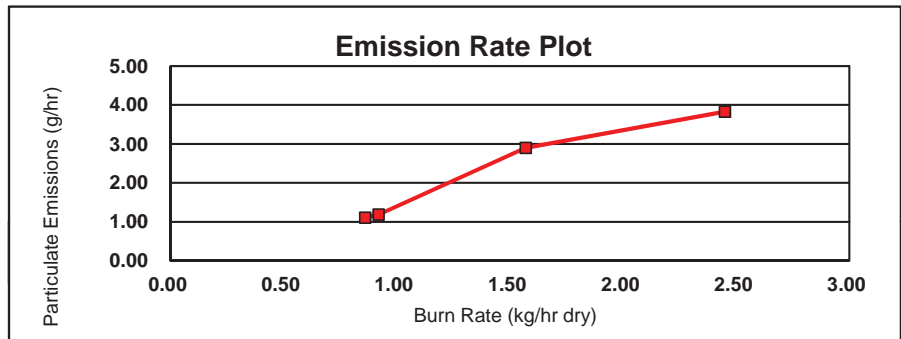

Run #	1		
Burn Rate (dry kg/hr)	0.86		
Category	2		
LHV Efficiency (%)	82.5		
HHV Efficiency (%)	76.3		
Emissions (g/hr)	1.11		
Weighting Factor	0.311	18.35%	

Run #	2		
Burn Rate (dry kg/hr)	0.92		
Category	2		
LHV Efficiency (%)	82		
HHV Efficiency (%)	75.8		
Emissions (g/hr)	1.19		
Weighting Factor	0.524	30.91%	

Run #	4		
Burn Rate (dry kg/hr)	1.57		
Category	3		
LHV Efficiency (%)	78.6		
HHV Efficiency (%)	72.7		
Emissions (g/hr)	2.9		
Weighting Factor	0.648	38.20%	

Run #	3		
Burn Rate (dry kg/hr)	2.45		
Category	4		
LHV Efficiency (%)	76.7		
HHV Efficiency (%)	70.9		
Emissions (g/hr)	3.83		
Weighting Factor	0.213	12.54%	

## Wood Heater Conditioning Data - ASTM E2780/ ASTM E2515

Manufacturer: Hearth & Home  
 Model: Explorer I  
 Tracking No.: 2135  
 Project No.: 0061WS091E  
 Test Date: 9/10 - 9/25/2015  
 Technician: W. Howe, M. Owings  
 Operation Category: II - III

Elapsed Time (hr)	Flue Gas Temp (degrees F)	Catalyst Exit Temp (degrees F)
0	203.0	
1	341.0	
2	203.0	
3	175.0	
4	437.0	
5	263.0	
6	463.0	
7	308.0	
8	179.0	
9	173.0	
10	511.0	
11	283.0	
12	189.0	
13	168.0	
14	156.0	
15	414.0	
16	237.0	
17	190.0	
18	162.0	
19	366.0	
20	225.0	
21	178.0	
22	176.0	
23	377.0	
24	195.0	
25	167.0	
26	151.0	
27	443.0	
28	271.0	
29	184.0	
30	151.0	
31	176.0	
32	295.0	

33	179.0	
34	153.0	
35	144.0	
36	424.0	
37	253.0	
38	282.0	
39	380.0	
40	246.0	
41	319.0	
42	163.0	
43	684.0	
44	417.0	
45	396.0	
46	282.0	
47	177.0	
48	138.0	
49	126.0	
50	119.0	

*Model: Explorer I  
Hearth & Home technologies  
1445 North Highway  
Colville, WA 99114*

# **Run 1**

### Wood Heater Test Results - ASTM E2780 / ASTM E2515

Manufacturer: Hearth & Home  
 Model: Explorer I  
 Project No.: 0061WS091E-Rev1  
 Tracking No.: 2135  
 Run: 1  
 Test Date: 09/28/15

Burn Rate	0.86 kg/hr dry
Average Tunnel Temperature	85 degrees Fahrenheit
Average Gas Velocity in Dilution Tunnel - vs	17.14 feet/second
Average Gas Flow Rate in Dilution Tunnel - Qsd	10959.8 dscf/hour
Average Delta p	0.080 inches H2O
Total Time of Test	310 minutes

	AMBIENT			SAMPLE TRAIN 1			SAMPLE TRAIN 2			FIRST HOUR FILTER (TRAIN 1)		
Total Sample Volume - Vm	80.386 cubic feet	49.728 cubic feet	51.673 cubic feet	9.480 cubic feet	82 degrees Fahrenheit	82 degrees Fahrenheit	82 degrees Fahrenheit	82 degrees Fahrenheit	82 degrees Fahrenheit	82 degrees Fahrenheit	82 degrees Fahrenheit	82 degrees Fahrenheit
Average Gas Meter Temperature	80 degrees Fahrenheit	82 degrees Fahrenheit	82 degrees Fahrenheit	82 degrees Fahrenheit	82 degrees Fahrenheit	82 degrees Fahrenheit	82 degrees Fahrenheit	82 degrees Fahrenheit	82 degrees Fahrenheit	82 degrees Fahrenheit	82 degrees Fahrenheit	82 degrees Fahrenheit
Total Sample Volume (Standard Conditions) - Vmstd	74.706 dscf	46.575 dscf	47.619 dscf	8.879 dscf	47.619 dscf	47.619 dscf	47.619 dscf	47.619 dscf	47.619 dscf	47.619 dscf	47.619 dscf	47.619 dscf
Total Particulates - m <sub>h</sub>	0.2 mg	5.3 mg	4.5 mg	3.4 mg	4.5 mg	4.5 mg	4.5 mg	4.5 mg	4.5 mg	4.5 mg	4.5 mg	4.5 mg
Particulate Concentration (dry-standard) - C <sub>f</sub> /C <sub>s</sub>	0.000003 grams/dscf	0.00011 grams/dscf	0.00009 grams/dscf	0.00038 grams/dscf	0.00009 grams/dscf	0.00009 grams/dscf	0.00009 grams/dscf	0.00009 grams/dscf	0.00009 grams/dscf	0.00009 grams/dscf	0.00009 grams/dscf	0.00038 grams/dscf
Total Particulate Emissions - E <sub>T</sub>	0.15 grams	6.29 grams	5.20 grams	4.20 grams	5.20 grams	5.20 grams	5.20 grams	5.20 grams	5.20 grams	5.20 grams	5.20 grams	4.20 grams
Particulate Emission Rate	0.03 grams/hour	1.22 grams/hour	1.01 grams/hour	1.01 grams/hour	1.01 grams/hour	1.01 grams/hour	1.01 grams/hour	1.01 grams/hour	1.01 grams/hour	1.01 grams/hour	1.01 grams/hour	4.20 grams/hour
Emissions Factor	1.41 g/kg	1.41 g/kg	1.17 g/kg	1.78 g/kg	1.17 g/kg	1.17 g/kg	1.17 g/kg	1.17 g/kg	1.17 g/kg	1.17 g/kg	1.17 g/kg	1.78 g/kg
Difference from Average Total Particulate Emissions	0.55 grams	0.55 grams	0.55 grams	0.55 grams	0.55 grams	0.55 grams	0.55 grams	0.55 grams	0.55 grams	0.55 grams	0.55 grams	0.55 grams

**Dual Train Comparison Results Are Acceptable**

FINAL AVERAGE RESULTS	
<b>Complete Test Run</b>	
Total Particulate Emissions - E <sub>T</sub>	5.75 grams
Particulate Emission Rate	1.11 grams/hour
Emissions Factor	1.29 grams/kg
<b>First Hour Emissions</b>	
Total Particulate Emissions - E <sub>T</sub>	4.20 grams
Particulate Emission Rate	4.20 grams/hour
Emissions Factor	1.78 grams/kg

# Wood Heater Test Data - ASTM E2780 / ASTM E2515

Run: 1

Manufacturer: Health & Home  
 Model: Explorer 1  
 Tracking No.: 2135  
 Project No.: 0061WS091E-Rev1  
 Test Date: 28-Sep-15  
 Clock Time: 12:36

Total Sampling Time: 310 min  
 Recording Interval: 10 min  
 Background Sample Volume: 80.386 cubic feet

PM Control Modules: 428  
 Dilution Tunnel MW(dry): 29.00 lb/lb-mole  
 Dilution Tunnel MW(wet): 28.78 lb/lb-mole  
 Dilution Tunnel H<sub>2</sub>O: 2.00 percent  
 Dilution Tunnel Static: -0.490 "H<sub>2</sub>O  
 Tunnel Area: 0.19535 ft<sup>2</sup>  
 Pilot Tube Cp: 0.99

Avg. Tunnel Velocity: 17.14 ft/sec  
 Initial Tunnel Flow: 180.4 scfm  
 Average Tunnel Flow: 182.7 scfm  
 Post-Test Leak Check (1): 0 cfm @ 4 in. Hg  
 Post-Test Leak Check (2): 0 cfm @ 5 in. Hg  
 Average Test Piece Fuel Moisture: 21.51 Dry Basis %

Meter Box Y Factor: 1.003 (1) 0.988 (2) 0.996 (Amb)

Barometric Pressure: 28.60 28.56 28.52 28.56 "Hg

OMNI Equipment Numbers: 432.565.413.5142132.132

Velocity Traverse Data									
	Pt.1	Pt.2	Pt.3	Pt.4	Pt.5	Pt.6	Pt.7	Pt.8	Center
Initial dP	0.052	0.072	0.072	0.060	0.072	0.052	0.048	0.080	H <sub>2</sub> O
Temp:	80	80	80	80	80	80	80	80	F
V <sub>slow</sub>	17.04 ft/sec								
V <sub>scout</sub>	19.40 ft/sec								
F <sub>p</sub>	0.878								

Elapsed Time (min)	Particulate Sampling Data										Fuel Weight (lb)					Temperature Data (°F)					Stack Gas Data		
	Gas Meter 1 (ft <sup>3</sup> )	Gas Meter 2 (ft <sup>3</sup> )	Sample Rate 1 (cfm)	Sample Rate 2 (cfm)	Orifice dH 1 ("H <sub>2</sub> O)	Meter 1 Temp (°F)	Meter 1 Vacuum ("Hg)	Orifice dH 2 ("H <sub>2</sub> O)	Meter 2 Temp (°F)	Meter 2 Vacuum ("Hg)	Dilution Tunnel Center dP	Pro. Rate 1	Pro. Rate 2	Scale Reading	Weight Change	Avg. Stove Surface Temp	Stack	Filter 1	Filter 2	Ambient	Draft ("H <sub>2</sub> O)	CO <sub>2</sub> (%)	CO (%)
0	0.000	0.000	0.16	0.16	-0.01	73	1.6	2.59	74	-2.5	0.080	99	99	11.0	354.2	152	78	75	76	76	-0.010	2.6	0.73
10	1.565	1.630	0.16	0.16	2.05	74	-1.6	2.59	74	-2.5	0.080	99	99	11.0	354.2	152	78	75	76	76	-0.040	11.08	0.43
20	3.141	3.277	0.16	0.16	2.05	75	-1.61	2.60	75	-2.5	0.080	100	101	9.3	-1.7	407.3	499	82	79	77	-0.060	16.18	0.32
30	4.717	4.929	0.16	0.17	2.05	76	-1.59	2.61	76	-2.5	0.080	100	101	8.1	-1.2	428.8	423	83	81	78	-0.050	13.18	0.54
40	6.293	6.585	0.16	0.17	2.05	77	-1.58	2.60	78	-2.5	0.080	100	101	7.0	-1.1	395.9	348	83	81	78	-0.040	13.3	0.61
50	7.868	8.245	0.16	0.17	2.07	78	-1.61	2.62	79	-2.5	0.080	100	101	6.2	-0.8	377.5	305	84	82	79	-0.030	12.18	0.43
60	9.440	9.905	0.16	0.17	2.08	79	-1.61	2.61	80	-2.5	0.080	100	100	5.4	-0.8	372.2	304	83	82	79	-0.030	11.06	0.58
70	11.082	11.566	0.16	0.17	2.06	79	-1.66	2.62	81	-2.5	0.080	101	100	4.6	-0.8	372.1	305	81	83	80	-0.030	11.4	0.41
80	12.687	13.228	0.16	0.17	2.05	80	-1.66	2.62	81	-2.5	0.080	101	100	3.9	-0.7	377.0	294	82	83	80	-0.030	12.3	0.26
90	14.294	14.891	0.16	0.17	2.05	81	-1.67	2.62	82	-2.5	0.080	100	100	3.2	-0.7	377.1	291	83	83	80	-0.030	12.9	0.28
100	15.892	16.556	0.16	0.17	2.06	81	-1.66	2.65	83	-2.5	0.080	100	100	2.7	-0.5	377.0	277	83	83	80	-0.030	12.64	0.25
110	17.501	18.220	0.16	0.17	2.06	82	-1.67	2.61	83	-2.5	0.080	100	100	2.3	-0.4	368.4	215	84	84	80	-0.020	12.48	0.31
120	19.108	19.889	0.16	0.17	2.05	82	-1.67	2.63	84	-2.5	0.080	100	100	2.1	-0.2	338.7	189	83	84	80	-0.010	10.52	0.69
130	20.719	21.557	0.16	0.17	2.06	83	-1.67	2.62	84	-2.5	0.080	100	100	1.9	-0.2	319.4	170	83	83	80	-0.010	8.78	1.26
140	22.333	23.227	0.16	0.17	2.07	83	-1.67	2.65	85	-2.5	0.080	100	100	1.8	-0.1	306.3	160	83	83	80	-0.010	7.8	1.56
150	23.951	24.900	0.16	0.17	2.06	83	-1.67	2.61	85	-2.5	0.080	101	100	1.7	-0.1	297.2	154	83	83	80	0.000	6.94	1.86
160	25.561	26.568	0.16	0.17	2.06	84	-1.67	2.64	85	-2.5	0.080	100	100	1.6	-0.1	288.7	148	83	83	81	0.000	6.5	2.07
170	27.173	28.241	0.16	0.17	2.06	84	-1.67	2.65	86	-2.5	0.080	100	100	1.5	-0.1	281.8	145	83	83	81	0.000	6.4	2.15
180	28.787	29.913	0.16	0.17	2.05	84	-1.67	2.61	86	-2.5	0.080	100	100	1.3	-0.2	275.5	144	83	83	81	0.000	6.26	2.14
190	30.396	31.583	0.16	0.17	2.07	85	-1.67	2.62	86	-2.5	0.080	100	100	1.2	-0.1	270.0	143	84	84	81	0.000	4.46	1.54
200	32.007	33.255	0.16	0.17	2.06	85	-1.67	2.62	87	-2.5	0.080	100	100	1.1	-0.1	264.7	140	84	84	81	0.000	4.42	1.56
210	33.616	34.927	0.16	0.17	2.05	85	-1.67	2.63	87	-2.5	0.080	100	100	1.0	-0.1	261.2	139	84	84	81	0.000	4.44	1.59
220	35.229	36.601	0.16	0.17	2.05	85	-1.67	2.61	87	-2.5	0.080	100	100	0.9	-0.1	258.2	138	84	84	81	0.000	4.36	1.66
230	36.845	38.276	0.16	0.17	2.05	86	-1.67	2.64	87	-2.5	0.080	100	100	0.8	-0.1	255.6	138	84	84	81	0.000	4.24	1.72
240	38.464	39.951	0.16	0.17	2.06	86	-1.68	2.61	88	-2.5	0.080	100	100	0.7	-0.1	253.4	137	84	84	81	0.000	4.16	1.72
250	40.071	41.626	0.16	0.17	2.05	86	-1.67	2.62	88	-2.5	0.080	99	100	0.6	-0.1	250.0	135	84	84	81	0.000	4.14	1.73
260	41.674	43.299	0.16	0.17	2.06	86	-1.67	2.61	88	-2.5	0.080	99	100	0.5	-0.1	246.6	132	84	84	81	0.000	4.1	1.7
270	43.284	44.973	0.16	0.17	2.06	86	-1.68	2.62	88	-2.5	0.080	100	100	0.4	-0.1	243.5	132	84	84	81	0.000	4.06	1.64
280	44.896	46.648	0.16	0.17	2.06	86	-1.68	2.62	88	-2.5	0.080	100	100	0.3	-0.1	240.5	132	84	84	81	0.000	4.02	1.51
290	46.506	48.323	0.16	0.17	2.05	87	-1.68	2.60	88	-2.5	0.080	99	100	0.2	-0.1	237.3	130	84	84	81	0.000	3.96	1.45
300	48.116	49.998	0.16	0.17	2.06	86	-1.67	2.64	88	-2.5	0.080	100	100	0.1	-0.1	234.5	128	84	84	81	0.000	3.86	1.52
310	49.728	51.673	0.16	0.17	2.05	86	-1.68	2.66	88	-2.5	0.080	100	100	0.0	-0.1	231.8	127	84	84	81	0.000	3.8	1.56

### Wood Heater Lab Data - ASTM E2780 / ASTM E2515

Manufacturer: <u>Hearth &amp; Home</u>	Equipment Numbers: <u>00023,00283A, 00291</u>
Model: <u>Explorer I</u>	
Tracking No.: <u>2135</u>	
Project No.: <u>0061WS091E-Rev1</u>	
Run #: <u>1</u>	
Date: <u>9/28/15</u>	

**TRAIN 1 (First Hour emissions)**

Sample Component	Reagent	Filter, Probe or Dish #	Weights		
			Final, mg	Tare, mg	Particulate, mg
B. Front filter catch	Filter	C108	126.5	124.0	2.5
C. Rear filter catch	Filter	C109	123.0	123.3	-0.3
D. Probe catch*	Probe	4	114870.4	114869.8	0.6
E. Filter seals catch*	Seals	R348	3475.5	3474.9	0.6

<b>Sub-Total</b>	Total Particulate, mg:	3.4
------------------	------------------------	-----

**TRAIN 1 (Post First Hour Change-out)**

Sample Component	Reagent	Filter, Probe or Dish #	Weights		
			Final, mg	Tare, mg	Particulate, mg
B. Front filter catch	Filter	C110	123.5	122.0	1.5
C. Rear filter catch	Filter	C111	121.2	121.1	0.1
D. Probe catch*	Probe	OES 4	114147.6	114147.4	0.2
E. Filter seals catch*	Seals	R349	3246.0	3245.9	0.1

<b>Sub-Total</b>	Total Particulate, mg:	1.9
------------------	------------------------	-----

<b>Train 1 Aggregate</b>	Total Particulate, mg:	5.3
--------------------------	------------------------	-----

**TRAIN 2**

Sample Component	Reagent	Filter, Probe or Dish #	Weights		
			Final, mg	Tare, mg	Particulate, mg
A. Front filter catch	Filter	C112	124.8	121.2	3.6
B. Rear filter catch	Filter	C113	122.7	122.6	0.1
C. Probe catch*	Probe	6	115359.8	115359.1	0.7
D. Filter seals catch*	Seals	R359	3510.6	3510.5	0.1

<b>Total Particulate, mg:</b>	<b>4.5</b>
-------------------------------	------------

**AMBIENT**

Sample Component	Reagent	Filter # or Probe #	Weights		
			Final, mg	Tare, mg	Particulate, mg
A. Front filter catch*	Filter	C107	121.3	121.1	0.2

<b>Total Particulate, mg:</b>	<b>0.2</b>
-------------------------------	------------

\*Particulate catch that results in a negative number, is assumed to be zero for probes and seals, negative numbers for filters are assumed to be part of the seal weight.

Component	Equations:
A. Front filter catch	Final (mg) - Tare (mg) = Particulate, mg
B. Rear filter catch	Final (mg) - Tare (mg) = Particulate, mg
C. Probe catch	Final (mg) - Tare (mg) = Particulate, mg



Manufacturer: Hearth & Home  
 Model: Explorer I  
 Tracking No.: 2135  
 Project No.: 0061WS091E-Rev1  
 Test Date: 28-Sep-15

**Preburn Data**

Time	Fuel Weight	Draft	Top	Bottom	Back	Left	Right	Average
0	5.2	-0.05						
10	4.2	-0.04						
20	3.7	-0.03						
30	3.2	-0.03						
40	2.9	-0.03						
50	2.8	-0.02						
60	2.7	-0.07	331	354	197	404	380	333.2

Temperature data was lost except for last reading.

### Wood Heater Test Fuel Data - ASTM E2780

Manufacturer: **Hearth & Home**  
 Model: **Explorer I**  
 Tracking No.: **2135**  
 Project No.: **0061WS091E**

Firebox Volume (ft <sup>3</sup> ):	1.67
Fuel Piece Length (in):	13
2x4 Crib Weight (lb):	5.3
4x4 Crib Weight (lb):	6.4

<b>Total Fuel Weight (Dry Basis, lb):</b>	9.8	
Fuel Density (lb/ft <sup>3</sup> , Dry Basis):	27.77	OK
Loading Density (lb/ft <sup>3</sup> , Wet Basis):	7.01	OK
2x4 Percentage:	45%	OK

Test Fuel Piece	Weight (lb)	Size	Readings (Dry Basis %)			Dry Weight (lb)
1	1.3	2"x 4"	19.5	20.5	19.4	1.09
2	1.2	2"x 4"	24.3	22.3	23.8	0.97
3	1.6	2"x 4"	24.3	21.7	22.0	1.30
4	3.2	4"x 4"	20.2	22.3	19.9	2.65
5	2.9	4"x 4"	19.3	19.4	23.8	2.40

Spacer Readings (Dry Basis %)			
7.1	6.8	8.2	7.0
7.4	8.7	6.7	7.3
7.4	6.5	8.4	8.0
8.3	7.3	9.4	8.1

### ASTM E2780 Wood Heater Run Sheets

Client: Hearth & Home Project Number: 061WS091E Run Number: 1  
 Model: Explorer I Tracking Number: 2135 Date: 9/28/15  
 Test Crew: B DAVIS  
 OMNI Equipment ID numbers: 132, 5142132, 186, 417, 566, 428

#### Wood Heater Supplemental Data

Start Time: 12:36 Booth #: E7

Stop Time: 17:46

**Stack Gas Leak Check:**

Initial: good Final: good

**Sample Train Leak Check:**

A: 0.0 @ 3" Hg  
 B: 0.0 @ 5" Hg

Calibrations: Span Gas CO<sub>2</sub>: 9.76 CO: 0.993

	Pre Test		Post Test	
	Zero	Span	Zero	Span
Time	<u>∅</u>	<u>∅</u>	<u>EOT</u>	<u>EOT</u>
CO <sub>2</sub>	<u>0.00</u> <u>9.76</u>	<u>9.76</u>	<u>0.02</u>	<u>9.76</u>
CO	<u>0.00</u> <u>0.993</u>	<u>0.993</u>	<u>0.00</u>	<u>1.02</u>

Air Velocity (ft/min): Initial: 150 Final: 150

Scale Audit (lbs): Initial: 10.0 Final: 10.0

Pitot Tube Leak Test: Initial: good Final: good

Stack Diameter (in): 6

Induced Draft: 0.0

% Smoke Capture: 100%

Flue Pipe Cleaned Prior to First Test in Series:

Date: 9/28/15 Initials: BD

	Initial	Middle	Ending
P <sub>b</sub> (in/Hg)	<u>28.60</u>	<u>28.56</u>	<u>28.52</u>
RH (%)			
Ambient (°F)	<u>76</u>	<u>81</u>	<u>81</u>

Tunnel Traverse		
Microtector Reading	dP (in H <sub>2</sub> O)	T (°F)
<u>1</u>	<u>.052</u> <u>.072</u>	<u>80</u>
<u>2</u>	<u>.072</u>	<u>80</u>
<u>3</u>	<u>.072</u>	<u>80</u>
<u>4</u>	<u>.052</u>	<u>80</u>
<u>1</u>	<u>.060</u>	<u>80</u>
<u>2</u>	<u>.072</u>	<u>80</u>
<u>3</u>	<u>.052</u>	<u>80</u>
<u>4</u>	<u>.048</u>	<u>80</u>
Center:		
	<u>.080</u>	<u>80</u>

Background Filter Volume: 80.386

Tunnel Static Pressure (in H <sub>2</sub> O):	
Beginning of Test	End of Test
<u>-.49</u>	<u>-.49</u>

Technician Signature: B DAVIS

Date: 10/13/15 130

Client: Hearth & Home Project Number: 061WS091E Run Number: 1  
 Model: Explorer I Tracking Number: 2135 Date: 9/24/15  
 Test Crew: B Dams  
 OMNI Equipment ID numbers: 566, 282

Wood Heater Run Notes

Air Control Settings

Primary:

Secondary: Fixed

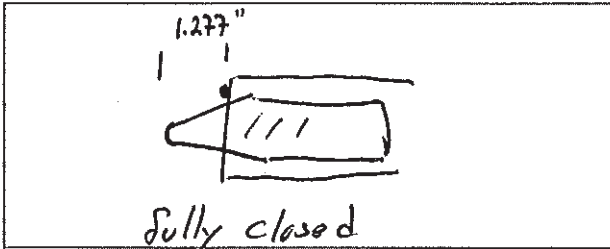

Tertiary/Pilot: Not used (Timed Air)

Fan: ON High

Preburn Notes

Time	Notes
50	Raked coals

Test Notes

Sketch test fuel configuration:

Start up procedures & Timeline:

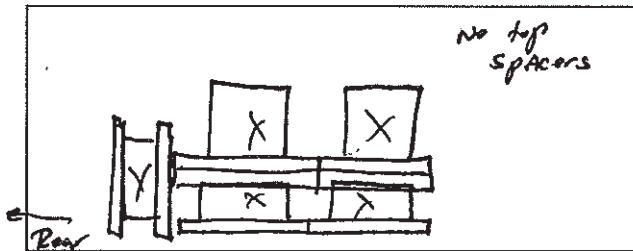

Bypass: NA  
 Fuel loaded by: 47 seconds  
 Door closed at: 1:00 minute  
 Primary air: At test setting entire test

Notes: Boost Air Activated at 0 minutes then set (pulled out) @ 1:00

Time	Notes
0	FAN off for first 30 minutes then turned to high for remainder of Test.

Technician Signature: [Signature]

Date: 10/12/15 131

**ASTM E2780 Wood Heater Run Sheets**

Client: Hearth & Home Project Number: 061WS091E Run Number: 1  
 Model: Explorer I Tracking Number: 2135 Date: 9/23/15  
 Test Crew: B Davis  
 OMNI Equipment ID numbers: 432, 296-TSY, 5142132

**Wood Heater Fuel Data**

Fuel: Douglas fir, untreated and air dried, standard grade or better dimensional lumber

**Pre-Burn Fuel**

Calibration: Cal Value (1) = 12% Actual Reading 12  
 Cal Value (2) = 22% Actual Reading 22

Piece:	Length:	Reading:	Piece:	Length:	Reading:
1	<u>8</u> in	<u>20.6</u>	7	_____ in	_____
2	<u>8</u> in	<u>20.3</u>	8	_____ in	_____
3	<u>8</u> in	<u>21.5</u>	9	_____ in	_____
4	_____ in	_____	10	_____ in	_____
5	_____ in	_____	11	_____ in	_____
6	_____ in	_____	12	_____ in	_____

Total Pre-Burn Fuel Weight: 2.5 ~~8.5 lb~~ Pre-Burn Fuel Average Moisture: 20.8

Time (clock): 11:05 Room Temperature (F): 70 Initials: DA

**Test Fuel**

Firebox Volume (ft<sup>3</sup>): 1.68 Test Fuel Piece Length (in): 13"  
 Load Weight Range (lb): 10.6 - 12.9 Total Wet Fuel Load Weight (lb): 11.7

Fuel Type & Amount: 2 x 4: 3 4 x 4: 2  
 Weight (with spacers): 5.3 Weight (with spacers): 5.5 6.4

Piece:	Weight (lbs):	Moisture Readings (%DB):				Fuel Type:
1	<u>1.3</u>	<u>19.5</u>	<u>20.5</u>	<u>19.4</u>	<u>2x4</u>	
2	<u>1.2</u>	<u>24.3</u>	<u>22.3</u>	<u>23.8</u>	<u>2x4</u>	
3	<u>1.6</u>	<u>24.3</u>	<u>21.7</u>	<u>22.0</u>	<u>2x4</u>	
4	<u>3.2</u>	<u>20.2</u>	<u>22.3</u>	<u>19.9</u>	<u>4x4</u>	
5	<u>2.9</u>	<u>19.3</u>	<u>19.4</u>	<u>23.8</u>	<u>4x4</u>	
6	_____	_____	_____	_____	_____	
7	_____	_____	_____	_____	_____	

**Spacer Moisture Readings (%DB)**

<u>2.1</u>	<u>6.8</u>	<u>8.2</u>	<u>7.0</u>	<u>7.4</u>	<u>8.7</u>	<u>6.7</u>	<u>7.3</u>
<u>7.4</u>	<u>6.5</u>	<u>8.4</u>	<u>8.0</u>	<u>8.3</u>	<u>7.3</u>	<u>9.4</u>	<u>8.1</u>
_____	_____	_____	_____	_____	_____	_____	_____
_____	_____	_____	_____	_____	_____	_____	_____

Time (clock): 11:05 Room Temperature (F): 70 Initials: DA

Technician Signature: [Signature]

Date: 10/13/15

VERSION: 2.2 12/14/2009

Manufacturer: Hearth & Home

Model: Explorer I

Date: 9/28/2015

Run: 1

Control #: 0061WS091E-Rev 1

Test Duration: 310

Output Category: 2

Appliance Type: Non-Cat (Cat, Non

Temp. Units F (F or C)

Weight Units lb (kg or lb)

Wood Moisture (% wet): 17.70  
 Load Weight (lb wet): 11.70  
 Burn Rate (dry kg/h): 0.85  
 Total Particulate Emissions: 5.745 g

Fuel Data

D. Fir

HHV 19,810 kj/kg

%C 48.73

%H 6.87

%O 43.9

%ASH 0.5

Averages 1.18 7.77 #DIV/0! 208.59 79.94

Temp. (°F)

Elapsed Time (min) Fuel Weight Remaining (lb) Flue Gas Composition (%) CO CO<sub>2</sub> O<sub>2</sub> Flue Gas Room Temp

Elapsed Time (min)	Fuel Weight Remaining (lb)	Flue Gas Composition (%) CO	CO <sub>2</sub>	O <sub>2</sub>	Flue Gas	Room Temp
0	11.70	0.73	2.60		152.0	76.0
10	11.00	0.43	11.08		401.0	76.0
20	9.30	0.32	16.18		499.0	77.0
30	8.10	0.54	13.18		423.0	78.0
40	7.00	0.61	13.30		348.0	78.0
50	6.20	0.43	12.18		305.0	79.0
60	5.40	0.58	11.06		304.0	79.0
70	4.60	0.41	11.40		305.0	79.0
80	3.90	0.26	12.30		294.0	80.0
90	3.20	0.28	12.90		291.0	80.0
100	2.70	0.25	12.64		277.0	80.0
110	2.30	0.31	12.48		215.0	80.0
120	2.10	0.69	10.52		189.0	80.0
130	1.90	1.26	8.78		170.0	80.0
140	1.80	1.56	7.80		160.0	80.0
150	1.70	1.86	6.94		154.0	80.0
160	1.60	2.07	6.50		148.0	81.0
170	1.50	2.15	6.40		145.0	81.0
180	1.30	2.14	6.26		144.0	81.0
190	1.20	1.54	4.46		143.0	81.0
200	1.10	1.56	4.42		140.0	81.0
210	1.00	1.59	4.44		138.0	81.0
220	0.90	1.66	4.36		139.0	81.0
230	0.80	1.72	4.24		138.0	81.0
240	0.70	1.72	4.16		137.0	81.0
250	0.60	1.73	4.14		135.0	81.0
260	0.50	1.70	4.10		132.0	81.0
270	0.40	1.64	4.06		132.0	81.0
280	0.30	1.51	4.02		132.0	81.0
290	0.20	1.45	3.96		130.0	81.0
300	0.10	1.52	3.86		128.0	81.0
310	0.00	1.56	3.80		127.0	81.0

# OMNI-Test Laboratories

**Manufacturer:** Hearth & Home  
**Model:** Explorer I  
**Date:** 09/28/15  
**Run:** 1  
**Control #:** I61WS091E-Rev 1  
**Test Duration:** 310  
**Output Category:** 2

**Technicians:** B. Davis  
 \_\_\_\_\_  
 \_\_\_\_\_  
 \_\_\_\_\_

## Test Results in Accordance with CSA B415.1-09

	HHV Basis	LHV Basis
Overall Efficiency	76.3%	82.5%
Combustion Efficiency	94.3%	94.3%
Heat Transfer Efficiency	81%	87.5%

Output Rate (kJ/h)	12,787	12,129	(Btu/h)
Burn Rate (kg/h)	0.85	1.86	(lb/h)
Input (kJ/h)	16,751	15,890	(Btu/h)

Test Load Weight (dry kg)	4.37	9.63	dry lb
MC wet (%)	17.7		
MC dry (%)	21.51		
Particulate (g)	5.745		
CO (g)	351		
Test Duration (h)	5.17		

Emissions	Particulate	CO
g/MJ Output	0.09	5.31
g/kg Dry Fuel	1.31	80.30
g/h	1.11	67.90
lb/MM Btu Output	0.20	12.34

Air/Fuel Ratio (A/F)	13.61
----------------------	-------

VERSION:

2.2

12/14/2009



*Model: Explorer I  
Hearth & Home technologies  
1445 North Highway  
Colville, WA 99114*

## **Run 2**

### Wood Heater Test Results - ASTM E2780 / ASTM E2515

Manufacturer: Hearth & Home  
 Model: Explorer I  
 Project No.: 061WS091E-Rev1  
 Tracking No.: 2135  
 Run: 2  
 Test Date: 09/29/15

Burn Rate	<b>0.92 kg/hr dry</b>
Average Tunnel Temperature	84 degrees Fahrenheit
Average Gas Velocity in Dilution Tunnel - vs	16.63 feet/second
Average Gas Flow Rate in Dilution Tunnel - Qsd	10625.8 dscf/hour
Average Delta p	0.072 inches H2O
Total Time of Test	300 minutes

	AMBIENT	SAMPLE TRAIN 1	SAMPLE TRAIN 2	FIRST HOUR FILTER (TRAIN 1)
Total Sample Volume - Vm	77.728 cubic feet	48.655 cubic feet	49.376 cubic feet	9.551 cubic feet
Average Gas Meter Temperature	77 degrees Fahrenheit	77 degrees Fahrenheit	79 degrees Fahrenheit	77 degrees Fahrenheit
Total Sample Volume (Standard Conditions) - Vmstd	72.341 dscf	45.855 dscf	45.771 dscf	9.001 dscf
Total Particulates - m <sub>n</sub>	0.2 mg	5.2 mg	5.3 mg	3.4 mg
Particulate Concentration (dry-standard) - C <sub>p</sub> /C <sub>s</sub>	0.000003 grams/dscf	0.00011 grams/dscf	0.00012 grams/dscf	0.00038 grams/dscf
Total Particulate Emissions - E <sub>T</sub>	0.15 grams	5.88 grams	6.01 grams	4.01 grams
Particulate Emission Rate	0.03 grams/hour	1.18 grams/hour	1.20 grams/hour	4.01 grams/hour
Emissions Factor		1.28 g/kg	1.31 g/kg	1.47 g/kg
Difference from Average Total Particulate Emissions		0.06 grams	0.06 grams	

**Dual Train Comparison Results Are Acceptable**

FINAL AVERAGE RESULTS	
<b>Complete Test Run</b>	
Total Particulate Emissions - E <sub>T</sub>	5.94 grams
Particulate Emission Rate	<b>1.19 grams/hour</b>
Emissions Factor	1.30 grams/kg
<b>First Hour Emissions</b>	
Total Particulate Emissions - E <sub>T</sub>	4.01 grams
Particulate Emission Rate	4.01 grams/hour
Emissions Factor	1.47 grams/kg

# Wood Heater Test Data - ASTM E2780 / ASTM E2515

Run: 2

Manufacturer: Hearth & Home  
 Model: Explorer I  
 Tracking No.: 2135  
 Project No.: 06TWS091E-Rev1  
 Test Date: 29-Sep-15  
 Beginning Clock Time: 10:40

PM Control Modules: 428  
 Dilution Tunnel MW(dry): 29.00 lb/lb-mole  
 Dilution Tunnel MW(wet): 28.78 lb/lb-mole  
 Dilution Tunnel H2O: 2.00 percent  
 Dilution Tunnel Static: -0.460 "H2O  
 Tunnel Area: 0.19635 ft<sup>2</sup>  
 Pilot Tube Cp: 0.99

Avg. Tunnel Velocity: 16.63 ft/sec.  
 Initial Tunnel Flow: 175.9 scfm  
 Average Tunnel Flow: 177.1 scfm  
 Post-Test Leak Check (1): 0 cfm @ 5 in. Hg  
 Post-Test Leak Check (2): 0 cfm @ 4 in. Hg  
 Average Test Piece Fuel Moisture: 21.07 Dry Basis %

Meter Box Y Factor: 1.003 (1) 0.988 (2) 0.996 (Amb)  
 Barometric Pressure: 28.53 28.46 28.42 28.47 "Hg  
 OMNI Equipment Numbers: 483.432.565.413.5142132.132

Velocity Traverse Data									
	Pt.1	Pt.2	Pt.3	Pt.4	Pt.5	Pt.6	Pt.7	Pt.8	Center
Initial dP	0.040	0.076	0.072	0.060	0.072	0.072	0.044	0.044	0.072
Temp:	76	76	76	76	76	76	76	76	76
V <sub>linv</sub>	16.49 ft/sec								
V <sub>cent</sub>	18.36 ft/sec								
F <sub>p</sub>	0.898								

Elapsed Time (min)	Particulate Sampling Data										Fuel Weight (lb)										Temperature Data (°F)										Stack Gas Data		
	Gas Meter 1 (ft <sup>3</sup> )	Gas Meter 2 (ft <sup>3</sup> )	Orifice dH1 ("H <sub>2</sub> O)	Meter 1 Temp (°F)	Meter 1 Vacuum ("Hg)	Orifice dH2 ("H <sub>2</sub> O)	Meter 2 Temp (°F)	Meter 2 Vacuum ("Hg)	Dilution Tunnel (°F)	Dilution Tunnel Center dP	Pro. Rate 1	Pro. Rate 2	Scale Reading	Weight Change	Avg. Slove Surface Temp	Stack	Filter 1	Filter 2	Ambient	Draft ("H <sub>2</sub> O)	CO <sub>2</sub> (%)	CO (%)											
0	0.000	0.000	-0.01	67	1.62	0.01	68	1	75	0.072	///	12.0	///	335.7	151	72	72	71	-0.010	3.24	0.91												
10	1.572	1.667	2.11	68	-1.68	2.58	68	-2.4	87	0.072	99	104	11.2	-0.8	363.7	485	75	73	71	-0.060	15.22	0.54											
20	3.150	3.316	2.10	69	-1.66	2.56	70	-2.4	91	0.072	99	102	9.4	-1.8	418.4	489	78	75	73	-0.060	15.24	0.53											
30	4.731	4.922	2.10	70	-1.62	2.56	71	-2.4	87	0.072	99	99	8.3	-1.1	434.5	443	81	76	74	-0.050	14.32	0.49											
40	6.329	6.556	2.11	71	-1.65	2.53	72	-2.4	88	0.072	100	101	6.8	-1.5	407.5	380	82	77	75	-0.040	13.3	0.52											
50	7.934	8.190	2.12	72	-1.64	2.53	73	-2.4	87	0.072	100	101	5.7	-1.1	405.3	361	82	77	75	-0.040	13	0.45											
60	9.551	9.865	2.12	73	-1.64	2.54	74	-2.4	87	0.072	101	103	4.7	-1.1	407.6	344	82	77	76	-0.040	13.2	0.36											
70	11.160	11.495	2.11	74	-1.68	2.55	75	-2.4	86	0.072	100	100	3.9	-0.8	405.0	329	76	78	77	-0.040	13.62	0.37											
80	12.756	13.122	2.10	75	-1.68	2.59	76	-2.4	85	0.072	99	99	3.1	-0.8	406.8	315	78	78	77	-0.030	13.72	0.45											
90	14.358	14.761	2.10	75	-1.67	2.56	76	-2.4	84	0.072	99	100	2.7	-0.4	391.9	249	78	78	77	-0.020	13.36	0.42											
100	15.965	16.398	2.08	76	-1.67	2.57	77	-2.4	83	0.072	99	100	2.4	-0.3	367.6	215	78	78	77	-0.020	8.52	1.3											
110	17.569	18.047	2.11	77	-1.67	2.54	78	-2.4	82	0.072	99	100	2.2	-0.2	351.3	197	79	78	78	-0.010	7.86	1.97											
120	19.174	19.695	2.09	77	-1.66	2.56	78	-2.4	82	0.072	99	100	2.0	-0.2	337.9	181	79	79	78	-0.010	7.54	2.01											
130	20.786	21.321	2.10	78	-1.66	2.54	79	-2.4	82	0.072	99	101	1.9	-0.1	325.9	172	79	79	78	-0.010	7.46	1.84											
140	22.397	22.985	2.10	79	-1.66	2.54	80	-2.4	82	0.072	99	101	1.7	-0.2	316.2	164	79	79	78	-0.010	7.48	1.94											
150	24.018	24.716	2.08	79	-1.66	2.55	80	-2.4	82	0.072	99	105	1.6	-0.1	307.8	159	79	79	78	-0.010	7.42	1.75											
160	25.636	26.265	2.10	80	-1.66	2.59	81	-2.4	82	0.072	99	104	1.4	-0.2	301.4	153	80	80	78	0.000	7.2	1.92											
170	27.251	27.971	2.07	80	-1.66	2.54	81	-2.4	82	0.072	99	103	1.3	-0.1	295.7	149	80	80	78	0.000	7.3	1.97											
180	28.874	29.568	2.09	81	-1.66	2.56	82	-2.4	82	0.072	99	96	1.2	-0.1	290.3	147	80	80	79	0.000	7.1	2.07											
190	30.501	31.236	2.08	81	-1.66	2.54	83	-2.4	83	0.072	100	100	1.1	-0.1	285.3	145	81	81	79	0.000	6.96	2.1											
200	32.130	32.871	2.07	82	-1.66	2.54	83	-2.4	83	0.072	99	98	0.9	-0.2	281.0	144	81	81	79	0.000	6.78	2.42											
210	33.773	34.510	2.13	82	-1.73	2.55	84	-2.4	83	0.072	100	99	0.8	-0.1	277.0	142	82	82	80	0.000	6.86	1.47											
220	35.427	36.188	2.10	83	-1.73	2.55	84	-2.4	84	0.072	101	101	0.7	-0.1	272.8	141	82	82	80	0.000	6.92	1.56											
230	37.084	37.884	2.15	83	-1.72	2.54	85	-2.4	84	0.072	101	102	0.6	-0.1	269.3	138	82	82	80	0.000	6.82	1.75											
240	38.739	39.465	2.12	84	-1.72	2.55	85	-2.4	84	0.072	101	95	0.5	-0.1	265.4	137	83	83	80	0.000	6.14	1.93											
250	40.399	41.122	2.13	84	-1.73	2.55	85	-2.4	84	0.072	101	99	0.4	-0.1	260.4	134	83	83	80	0.000	5.6	2.01											
260	42.048	42.771	2.13	81	-1.75	2.53	84	-2.4	84	0.072	101	99	0.3	-0.1	254.6	132	83	83	79	0.000	5.52	1.96											
270	43.704	44.470	2.13	80	-1.75	2.54	83	-2.4	84	0.072	102	102	0.2	-0.1	249.1	129	83	83	79	0.000	5.28	2.11											
280	45.357	46.082	2.15	79	-1.76	2.58	82	-2.4	84	0.072	102	97	0.2	0	243.4	127	83	83	79	0.000	4.66	1.95											
290	47.004	47.752	2.14	79	-1.76	2.56	81	-2.4	85	0.072	101	101	0.1	-0.1	236.8	125	83	83	79	0.000	4.26	1.97											
300	48.655	49.376	2.15	79	-1.76	2.55	81	-2.4	84	0.072	101	98	0.0	-0.1	230.1	123	83	83	79	0.000	4.6	1.79											
Avg/Tot	48.655	49.376	2.04	77	///	2.47	79	///	84	0.072	100	100	///	///	105.6	///	80	79	77	-0.015	///	///											

### Wood Heater Lab Data - ASTM E2780 / ASTM E2515

Manufacturer: Hearth & Home      Equipment Numbers: 00023,00283A, 00291  
 Model: Explorer I  
 Tracking No.: 2135  
 Project No.: 061WS091E-Rev1  
 Run #: 2  
 Date: 9/29/15

**TRAIN 1 (First Hour emissions)**

Sample Component	Reagent	Filter, Probe or Dish #	Weights		
			Final, mg	Tare, mg	Particulate, mg
B. Front filter catch	Filter	C115	123.3	120.6	2.7
C. Rear filter catch	Filter	C116	122.3	122.1	0.2
D. Probe catch*	Probe	8	115601.1	115600.6	0.5
E. Filter seals catch*	Seals	R360	3309.1	3309.3	0.0

**Sub-Total**    Total Particulate, mg:    **3.4**

**TRAIN 1 (Post First Hour Change-out)**

Sample Component	Reagent	Filter, Probe or Dish #	Weights		
			Final, mg	Tare, mg	Particulate, mg
B. Front filter catch	Filter	C117	121.7	120.8	0.9
C. Rear filter catch	Filter	C118	120.8	120.7	0.1
D. Probe catch*	Probe	11	114196.7	114196.3	0.4
E. Filter seals catch*	Seals	R361	4917.1	4916.7	0.4

**Sub-Total**    Total Particulate, mg:    **1.8**

**Train 1 Aggregate**    Total Particulate, mg:    **5.2**

**TRAIN 2**

Sample Component	Reagent	Filter, Probe or Dish #	Weights		
			Final, mg	Tare, mg	Particulate, mg
A. Front filter catch	Filter	C119	125.1	122.0	3.1
B. Rear filter catch	Filter	C120	121.5	121.2	0.3
C. Probe catch*	Probe	13	114327.2	114326.9	0.3
D. Filter seals catch*	Seals	R362	3381.4	3379.8	1.6

**Total Particulate, mg:    5.3**

**AMBIENT**

Sample Component	Reagent	Filter # or Probe #	Weights		
			Final, mg	Tare, mg	Particulate, mg
A. Front filter catch*	Filter	C114	121.9	121.7	0.2

**Total Particulate, mg:    0.2**

\*Particulate catch that results in a negative number, is assumed to be zero for probes and seals, negative numbers for filters are assumed to be part of the seal weight.

Component	Equations:
A. Front filter catch	Final (mg) - Tare (mg) = Particulate, mg
B. Rear filter catch	Final (mg) - Tare (mg) = Particulate, mg
C. Probe catch	Final (mg) - Tare (mg) = Particulate, mg

Manufacturer: Hearth & Home  
 Model: Explorer I  
 Tracking No.: 2135  
 Project No.: 061WS091E-Rev1  
 Test Date: 29-Sep-15

**Preburn Data**

Run 2

Time	Fuel Weight	Draft	Top	Bottom	Back	Left	Right	Avg.
0	5.3	-0.05	653	422	309	613	557	
10	4.7	-0.04	591	445	288	577	531	
20	4.1	-0.04	517	431	258	526	497	
30	3.7	-0.03	464	410	239	488	475	
40	3.4	-0.03	432	394	227	460	458	
50	3.2	-0.02	379	378	210	428	432	
60	2.9	-0.02	322	365	200	392	395	334.8

### Wood Heater Test Fuel Data - ASTM E2780

Manufacturer: **Hearth & Home**  
 Model: **Explorer I**  
 Tracking No.: **2135**  
 Project No.: **0061WS091E-Rev-1**

Firebox Volume (ft <sup>3</sup> ):	1.67	<b>Total Fuel Weight (Dry Basis, lb):</b>	10.1	
Fuel Piece Length (in):	13	Fuel Density (lb/ft <sup>3</sup> , Dry Basis):	28.73	OK
2x4 Crib Weight (lb):	6.2	Loading Density (lb/ft <sup>3</sup> , Wet Basis):	7.19	OK
4x4 Crib Weight (lb):	5.8	2x4 Percentage:	52%	OK

Test Fuel Piece	Weight (lb)	Size	Readings (Dry Basis %)			Dry Weight (lb)
1	1.7	2"x 4"	24.5	23.8	21.9	1.38
2	1.6	2"x 4"	24.3	22.2	23.1	1.30
3	1.4	2"x 4"	19.5	18.9	20.5	1.17
4	2.9	4"x 4"	19.3	19.5	18.7	2.43
5	2.9	4"x 4"	21.4	18.7	19.7	2.42

Spacer Readings (Dry Basis %)			
6.7	7.7	6.5	8.0
8.0	7.8	6.7	7.9
7.9	7.7	8.0	8.2
8.0	8.0	7.6	7.6

### ASTM E2780 Wood Heater Run Sheets

Client: Hearth & Home Project Number: 061WS091E Run Number: 2  
 Model: Explorer I Tracking Number: 2135 Date: 9/29/15  
 Test Crew: D. Daus  
 OMNI Equipment ID numbers: 132, 5142132, 186, 417, 566, 428

#### Wood Heater Supplemental Data

Start Time: 10:40 Booth #: E7

Stop Time: 15:40

**Stack Gas Leak Check:**

Initial: good Final: good

**Sample Train Leak Check:**

A: 0.0 @ 5"Hg  
 B: 0.0 @ 5"Hg

Calibrations: Span Gas CO<sub>2</sub>: 9.76 CO: 0.993

	Pre Test		Post Test	
	Zero	Span	Zero	Span
Time	<u>Ø</u>	<u>Ø</u>	<u>EOT</u>	<u>EOT</u>
CO <sub>2</sub>	<u>0.00</u>	<u>9.76</u>	<u>0.00</u>	<u>9.78</u>
CO	<u>0.00</u>	<u>0.99</u>	<u>0.00</u>	<u>1.02</u>

Air Velocity (ft/min): Initial: 250 Final: 250

Scale Audit (lbs): Initial: 10.0 Final: 10.0

Pitot Tube Leak Test: Initial: good Final: good

Stack Diameter (in): 6"

Induced Draft: 0.0

% Smoke Capture: 100%

Flue Pipe Cleaned Prior to First Test in Series:

Date: 9/24/15 Initials: DD

	Initial	Middle	Ending
P <sub>b</sub> (in/Hg)	<u>28.53</u>	<u>28.46</u>	<u>28.42</u>
RH (%)			
Ambient (°F)	<u>71</u>	<u>78</u>	<u>79</u>

Tunnel Traverse		
Microtector Reading	dP (in H <sub>2</sub> O)	T(°F)
1	<u>.040</u>	<u>76</u>
2	<u>.076</u>	<u>76</u>
3	<u>.072</u>	<u>76</u>
4	<u>.060</u>	<u>76</u>
1	<u>.050</u>	<u>76</u>
2	<u>.072</u>	<u>76</u>
3	<u>.044</u>	<u>76</u>
4	<u>.044</u>	<u>76</u>
Center:		
	<u>.072</u>	<u>76</u>

Background Filter Volume: 77.328

Tunnel Static Pressure (in H <sub>2</sub> O):	
Beginning of Test	End of Test
<u>-.46</u>	<u>-.46</u>

Technician Signature: [Signature]

Date: 10/13/15 141



**ASTM E2780 Wood Heater Run Sheets**

Client: Hearth & Home Project Number: 061WS091E Run Number: 2  
 Model: Explorer I Tracking Number: 2135 Date: 9/29/15  
 Test Crew: B Davis  
 OMNI Equipment ID numbers: 566, 282

**Wood Heater Run Notes**

**Air Control Settings**

Primary:

Secondary:

Fixed

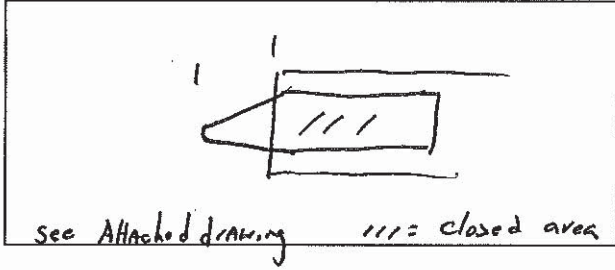

Tertiary/Pilot:

Timed Air not used

Fan:

on High

**Preburn Notes**

Time	Notes
50	Raked coals

**Test Notes**

Sketch test fuel configuration:

Start up procedures & Timeline:

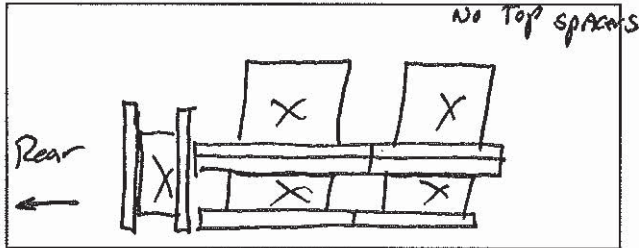

Bypass:

NA

Fuel loaded by:

1:15

Door closed at:

1:30

Primary air:

At test setting entire test

Notes:

Boost Air pushed in @ 6 minutes, pulled out AFTER door closed 1:30

Time	Notes
0	Fan off for first 30 minutes then turned to high for remainder of test.

Technician Signature: B. Davis

Date: 10/13/15

BD = 10/13/15

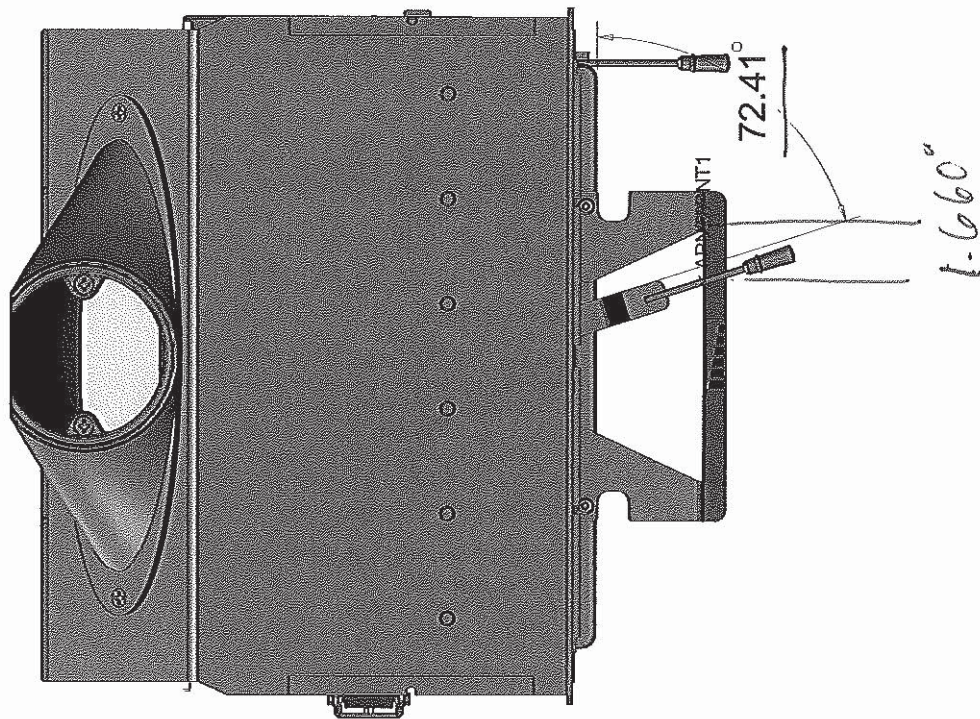

Medium Low Settings  
9-30-15  
GA

**ASTM E2780 Wood Heater Run Sheets**

Client: Hearth & Home Project Number: 061WS091E Run Number: 2  
 Model: Explorer I Tracking Number: 2135 Date: 9/29/15  
 Test Crew: B. Davis  
 OMNI Equipment ID numbers: 432, 296-754, 5142132

**Wood Heater Fuel Data**

Fuel: Douglas fir, untreated and air dried, standard grade or better dimensional lumber

**Pre-Burn Fuel**

Calibration: Cal Value (1) = 12% Actual Reading 12.0  
 Cal Value (2) = 22% Actual Reading 22.0

Piece:	Length:	Reading:	Piece:	Length:	Reading:
1	<u>8</u> in	<u>20.2</u>	7	_____ in	_____
2	<u>8</u> in	<u>20.5</u>	8	_____ in	_____
3	<u>8</u> in	<u>18.6</u>	9	_____ in	_____
4	_____ in	_____	10	_____ in	_____
5	_____ in	_____	11	_____ in	_____
6	_____ in	_____	12	_____ in	_____

Total Pre-Burn Fuel Weight: 2.5 Pre-Burn Fuel Average Moisture: 19.76  
 Time (clock): 0835 Room Temperature (F): 68 Initials: AS

**Test Fuel**

Firebox Volume (ft<sup>3</sup>): 1.68 Test Fuel Piece Length (in): 13.0  
 Load Weight Range (lb): \_\_\_\_\_ Total Wet Fuel Load Weight (lb): 12.0

Fuel Type & Amount: 2 x 4: 3 4 x 4: 2  
 Weight (with spacers): 6.2 Weight (with spacers): 5.8

Piece:	Weight (lbs):	Moisture Readings (%DB):		Fuel Type:
1	<u>1.7</u>	<u>24.5</u>	<u>23.8</u>	<u>2x4</u>
2	<u>1.6</u>	<u>24.3</u>	<u>22.2</u>	<u>2x4</u>
3	<u>1.4</u>	<u>19.5</u>	<u>18.9</u>	<u>2x4</u>
4	<u>2.9</u>	<u>19.3</u>	<u>19.5</u>	<u>4x4</u>
5	<u>2.9</u>	<u>21.4</u>	<u>18.7</u>	<u>4x4</u>
6	_____	_____	_____	_____
7	_____	_____	_____	_____

**Spacer Moisture Readings (%DB)**

<u>6.7</u>	<u>8.0</u>	<u>7.9</u>	<u>8.0</u>	<u>7.7</u>	<u>7.8</u>	<u>7.7</u>	<u>8.0</u>
<u>6.5</u>	<u>6.7</u>	<u>8.0</u>	<u>7.6</u>	<u>8.0</u>	<u>7.9</u>	<u>8.2</u>	<u>7.6</u>
_____	_____	_____	_____	_____	_____	_____	_____
_____	_____	_____	_____	_____	_____	_____	_____

Time (clock): 0835 Room Temperature (F): 68 Initials: AS

Technician Signature: [Signature]

Date: 10/13/15

VERSION: 2.2

12/14/2009

Manufacturer: Hearth & Home

Model: Explorer I

Date: 9/29/2015

Run: 2

Control #: 0061WS091E-Rev 1

Test Duration: 300

Output Category: 2

Appliance Type: Non-Cat (Cat, Non

Temp. Units F (F or C)

Weight Units lb (kg or lb)

Wood Moisture (% wet): 17.40  
 Load Weight (lb wet): 12.00  
 Burn Rate (dry kg/h): 0.90  
 Total Particulate Emissions: 5.945 g

Fuel Data

D. Fir

HHV 19,810 kJ/kg

%C 48.73

%H 6.87

%O 43.9

%ASH 0.5

Averages 1.45 8.59 #DIV/0! 216.13 77.45

Temp. (°F)

Elapsed Time (min) Fuel Weight Remaining (lb) Flue Gas Composition (%) CO CO<sub>2</sub> O<sub>2</sub> Flue Gas Room Temp

Elapsed Time (min)	Fuel Weight Remaining (lb)	Flue Gas Composition (%) CO	CO <sub>2</sub>	O <sub>2</sub>	Flue Gas	Room Temp
0	12.00	0.91	3.24		151.0	71.0
10	11.20	0.54	15.22		485.0	71.0
20	9.40	0.53	15.24		489.0	73.0
30	8.30	0.49	14.32		443.0	74.0
40	6.80	0.52	13.30		380.0	75.0
50	5.70	0.45	13.00		361.0	75.0
60	4.70	0.36	13.20		344.0	76.0
70	3.90	0.37	13.62		329.0	77.0
80	3.10	0.45	13.72		315.0	77.0
90	2.70	0.42	13.36		249.0	77.0
100	2.40	1.30	8.52		215.0	77.0
110	2.20	1.97	7.86		197.0	78.0
120	2.00	2.01	7.54		181.0	78.0
130	1.90	1.84	7.46		172.0	78.0
140	1.70	1.94	7.48		164.0	78.0
150	1.60	1.75	7.42		159.0	78.0
160	1.40	1.92	7.20		153.0	78.0
170	1.30	1.97	7.30		149.0	78.0
180	1.20	2.07	7.10		147.0	79.0
190	1.10	2.10	6.96		145.0	79.0
200	0.90	2.42	6.78		144.0	79.0
210	0.80	1.47	6.86		142.0	80.0
220	0.70	1.56	6.92		141.0	80.0
230	0.60	1.75	6.62		138.0	80.0
240	0.50	1.93	6.14		137.0	80.0
250	0.40	2.01	5.60		134.0	80.0
260	0.30	1.96	5.52		132.0	79.0
270	0.20	2.11	5.28		129.0	79.0
280	0.20	1.95	4.66		127.0	79.0
290	0.10	1.97	4.26		125.0	79.0
300	0.00	1.79	4.60		123.0	79.0

# OMNI-Test Laboratories

**Manufacturer:** Hearth & Home  
**Model:** Explorer I  
**Date:** 09/29/15  
**Run:** 2  
**Control #:** I61WS091E-Rev 1  
**Test Duration:** 300  
**Output Category:** 2

**Technicians:** B. Davis  
 \_\_\_\_\_  
 \_\_\_\_\_

### Test Results in Accordance with CSA B415.1-09

	HHV Basis	LHV Basis
Overall Efficiency	75.8%	82.0%
Combustion Efficiency	94.1%	94.1%
Heat Transfer Efficiency	81%	87.1%

Output Rate (kJ/h)	13,515	12,820	(Btu/h)
Burn Rate (kg/h)	0.90	1.98	(lb/h)
Input (kJ/h)	17,818	16,903	(Btu/h)

Test Load Weight (dry kg)	4.50	9.91	dry lb
MC wet (%)	17.4		
MC dry (%)	21.07		
Particulate (g)	5.945		
CO (g)	368		
Test Duration (h)	5.00		

Emissions	Particulate	CO
g/MJ Output	0.09	5.44
g/kg Dry Fuel	1.32	81.72
g/h	1.19	73.50
lb/MM Btu Output	0.20	12.64

Air/Fuel Ratio (A/F)	12.11
----------------------	-------

VERSION:                      2.2                      12/14/2009

*Model: Explorer I  
Hearth & Home technologies  
1445 North Highway  
Colville, WA 99114*

## **Run 3**

### Wood Heater Test Results - ASTM E2780 / ASTM E2515

Manufacturer: Hearth & Home  
 Model: Explorer I  
 Project No.: 061WS091E-Rev1  
 Tracking No.: 2135  
 Run: 3  
 Test Date: 09/30/15

Burn Rate	<b>2.45 kg/hr dry</b>
Average Tunnel Temperature	100 degrees Fahrenheit
Average Gas Velocity in Dilution Tunnel - vs	17.11 feet/second
Average Gas Flow Rate in Dilution Tunnel - Qsd	10627.1 dscf/hour
Average Delta p	0.072 inches H2O
Total Time of Test	115 minutes

	AMBIENT			SAMPLE TRAIN 1			SAMPLE TRAIN 2			FIRST HOUR FILTER (TRAIN 1)		
Total Sample Volume - Vm	29.318 cubic feet	18.271 cubic feet	18.271 cubic feet	18.271 cubic feet	18.271 cubic feet	18.271 cubic feet	18.501 cubic feet	18.501 cubic feet	9.475 cubic feet	9.475 cubic feet	9.475 cubic feet	
Average Gas Meter Temperature	80 degrees Fahrenheit	75 degrees Fahrenheit	75 degrees Fahrenheit	75 degrees Fahrenheit	75 degrees Fahrenheit	75 degrees Fahrenheit	76 degrees Fahrenheit	76 degrees Fahrenheit	75 degrees Fahrenheit	75 degrees Fahrenheit	75 degrees Fahrenheit	
Total Sample Volume (Standard Conditions) - Vmstd	27.150 dscf	17.301 dscf	17.301 dscf	17.301 dscf	17.301 dscf	17.301 dscf	17.254 dscf	17.254 dscf	8.972 dscf	8.972 dscf	8.972 dscf	
Total Particulates - m <sub>h</sub>	0.2 mg	6.4 mg	6.4 mg	6.4 mg	6.4 mg	6.4 mg	6.3 mg	6.3 mg	5.7 mg	5.7 mg	5.7 mg	
Particulate Concentration (dry-standard) - C <sub>p</sub> /C <sub>s</sub>	0.000007 grams/dscf	0.00037 grams/dscf	0.00037 grams/dscf	0.00037 grams/dscf	0.00037 grams/dscf	0.00037 grams/dscf	0.00037 grams/dscf	0.00037 grams/dscf	0.00064 grams/dscf	0.00064 grams/dscf	0.00064 grams/dscf	
Total Particulate Emissions - E <sub>T</sub>	0.15 grams	7.38 grams	7.38 grams	7.38 grams	7.38 grams	7.38 grams	7.29 grams	7.29 grams	6.75 grams	6.75 grams	6.75 grams	
Particulate Emission Rate	0.08 grams/hour	3.85 grams/hour	3.85 grams/hour	3.85 grams/hour	3.85 grams/hour	3.85 grams/hour	3.80 grams/hour	3.80 grams/hour	6.75 grams/hour	6.75 grams/hour	6.75 grams/hour	
Emissions Factor		1.57 g/kg	1.57 g/kg	1.57 g/kg	1.57 g/kg	1.57 g/kg	1.55 g/kg	1.55 g/kg	1.75 g/kg	1.75 g/kg	1.75 g/kg	
Difference from Average Total Particulate Emissions		0.05 grams	0.05 grams	0.05 grams	0.05 grams	0.05 grams	0.05 grams	0.05 grams				

**Dual Train Comparison Results Are Acceptable**

FINAL AVERAGE RESULTS	
<b>Complete Test Run</b>	
Total Particulate Emissions - E <sub>T</sub>	7.34 grams
Particulate Emission Rate	<b>3.83 grams/hour</b>
Emissions Factor	1.56 grams/kg
<b>First Hour Emissions</b>	
Total Particulate Emissions - E <sub>T</sub>	6.75 grams
Particulate Emission Rate	6.75 grams/hour
Emissions Factor	1.75 grams/kg



# Wood Heater Test Data - ASTM E2780 / ASTM E2515

Run: **3**

Manufacturer: Hearth & Home  
 Model: Explorer I  
 Tracking No.: 2135  
 Project No.: 061W5091E-Rev1  
 Test Date: 30-Sep-15  
 Beginning Clock Time: 10:34

Total Sampling Time: 115 min  
 Recording Interval: 5 min  
 Background Sample Volume: 29.318 cubic feet  
 Meter Box Y Factor: 1.003 (1) 0.988 (2) 0.996 (Amb)

PM Control Modules: 428  
 Dilution Tunnel MW(dry): 29.00 lb/lb-mole  
 Dilution Tunnel MW(wet): 28.78 lb/lb-mole  
 Dilution Tunnel H<sub>2</sub>O: 2.00 percent  
 Dilution Tunnel Status: -0.460 "H<sub>2</sub>O  
 Tunnel Area: 0.19635 ft<sup>2</sup>  
 Pitot Tube Cp: 0.99  
 Avg. Tunnel Velocity: 17.11 ft/sec.  
 Initial Tunnel Flow: 174.6 scfm  
 Average Tunnel Flow: 177.1 scfm  
 Post-Test Leak Check (1): 0 cfm @ 6 in. Hg  
 Post-Test Leak Check (2): 0 cfm @ 5 in. Hg  
 Average Test Piece Fuel Moisture: 23.27 Dry Basis %

Velocity Traverse Data									
	Pt.1	Pt.2	Pt.3	Pt.4	Pt.5	Pt.6	Pt.7	Pt.8	Center
Initial dP	0.052	0.060	0.074	0.054	0.056	0.072	0.050	0.048	0.072
Temp: 103	102	101	101	100	96	95	94	93	94
V <sub>air</sub>	17.02	ft/sec	V <sub>cent</sub>	18.68	ft/sec	F <sub>p</sub>	0.911		

Barometric Pressure: 28.48 28.48 28.48 "Hg  
 Average

OMNI Equipment Numbers: \_\_\_\_\_

Elapsed Time (min)	Particulate Sampling Data										Fuel Weight (lb)				Temperature Data (°F)				Stack Gas Data					
	Gas Meter 1 (ft <sup>3</sup> )	Gas Meter 2 (ft <sup>3</sup> )	Sample Rate 1 (cfm)	Sample Rate 2 (cfm)	Orifice dH1 ("H <sub>2</sub> O)	Meter 1 Temp (°F)	Meter 1 Vacuum ("Hg)	Orifice dH2 ("H <sub>2</sub> O)	Meter 2 Temp (°F)	Meter 2 Vacuum ("Hg)	Dilution Tunnel (°F)	Dilution Tunnel Center dP	Pro. Rate 1	Pro. Rate 2	Scale Reading	Weight Change	Avg. Slove Surface Temp	Stack	Filter 1	Filter 2	Ambient	Draft ("H <sub>2</sub> O)	CO <sub>2</sub> (%)	CO (%)
0	0.000	0.000	0.15	0.16	-0.01	70	1.6	0.01	70	1	92	0.072	98	97	12.5	0.7	478.5	379	79	76	77	-0.040	6.6	0.59
5	0.773	0.777	0.15	0.16	2.12	70	-1.63	2.51	70	-2.4	97	0.072	98	97	11.8	-0.7	465.4	505	83	79	77	-0.060	12.9	0.43
10	1.559	1.582	0.16	0.16	2.08	70	-1.64	2.48	70	-2.4	103	0.072	100	101	10.8	-1	476.4	619	85	80	77	-0.060	17	0.78
15	2.350	2.386	0.16	0.16	2.08	71	-1.62	2.47	71	-2.4	104	0.072	101	101	9.7	-1.1	483.2	612	83	79	78	-0.060	15.72	1.07
20	3.141	3.189	0.16	0.16	2.08	72	-1.62	2.47	72	-2.4	107	0.072	101	101	8.4	-1.3	489.6	642	81	78	79	-0.070	16.46	1.29
25	3.930	3.983	0.16	0.16	2.08	72	-1.61	2.47	72	-2.4	107	0.072	100	101	7.4	-1	494.5	631	81	79	79	-0.070	17	1.12
30	4.721	4.797	0.16	0.16	2.07	73	-1.61	2.47	73	-2.4	110	0.072	101	101	6.2	-1.2	503.2	652	81	79	80	-0.070	17.12	1.21
35	5.506	5.600	0.16	0.16	2.06	73	-1.62	2.46	74	-2.4	109	0.072	100	101	5.1	-1.1	510.1	636	82	79	81	-0.070	17.5	1.82
40	6.293	6.403	0.16	0.16	2.05	74	-1.64	2.45	74	-2.4	110	0.072	100	101	4.1	-1	514.9	622	82	80	81	-0.060	16.52	1.69
45	7.079	7.206	0.16	0.16	2.06	74	-1.65	2.46	75	-2.4	108	0.072	100	101	3.3	-0.8	520.7	590	82	80	82	-0.060	15.34	0.84
50	7.867	8.009	0.16	0.16	2.10	74	-1.7	2.45	75	-2.4	106	0.072	100	100	2.7	-0.6	526.2	553	82	80	82	-0.060	13.22	0.28
55	8.671	8.813	0.16	0.16	2.09	75	-1.69	2.45	76	-2.4	102	0.072	101	100	2.3	-0.4	524.2	486	82	80	82	-0.050	10.72	0.18
60	9.475	9.618	0.16	0.16	2.08	75	-1.68	2.46	76	-2.4	100	0.072	101	100	2.0	-0.3	514.3	456	82	80	82	-0.050	9.72	0.29
65	10.281	10.423	0.16	0.16	2.04	76	-1.56	2.47	77	-2.4	98	0.072	101	100	1.7	-0.3	503.1	438	80	79	81	-0.050	9.24	0.31
70	11.077	11.230	0.16	0.16	2.04	76	-1.57	2.49	77	-2.4	97	0.072	100	100	1.5	-0.2	493.5	433	81	79	81	-0.050	9.18	0.37
75	11.880	12.035	0.16	0.16	2.04	77	-1.57	2.46	77	-2.4	96	0.072	100	99	1.3	-0.2	484.4	418	82	79	81	-0.040	8.84	0.49
80	12.670	12.842	0.16	0.16	2.06	77	-1.57	2.47	78	-2.4	96	0.072	99	100	1.0	-0.3	474.6	404	83	79	81	-0.040	8.46	0.51
85	13.463	13.649	0.16	0.16	2.06	77	-1.57	2.45	78	-2.4	95	0.072	99	99	0.9	-0.1	465.4	390	83	79	81	-0.040	7.82	0.7
90	14.256	14.457	0.16	0.16	2.06	78	-1.56	2.49	79	-2.4	95	0.072	99	99	0.7	-0.2	456.3	376	83	79	81	-0.040	8.18	0.48
95	15.052	15.266	0.16	0.16	2.06	78	-1.57	2.46	79	-2.4	94	0.072	99	99	0.6	-0.1	449.7	374	84	79	81	-0.040	8	0.5
100	15.858	16.075	0.16	0.16	2.07	78	-1.61	2.50	79	-2.4	94	0.072	100	99	0.4	-0.2	445.0	369	84	79	81	-0.040	7.8	0.55
105	16.659	16.882	0.16	0.16	2.09	79	-1.61	2.49	80	-2.4	94	0.072	100	99	0.2	-0.2	440.6	363	84	79	81	-0.040	7.88	0.66
110	17.462	17.692	0.16	0.16	2.08	79	-1.61	2.49	80	-2.4	93	0.072	100	99	0.1	-0.1	435.5	354	84	78	81	-0.030	7.34	0.79
115	18.271	18.501	0.16	0.16	1.98	75	-1.61	2.46	80	-2.4	93	0.072	100	99	0.0	-0.1	429.8	343	84	78	81	-0.030	6.9	1.04
Avg/Tot	18.271	18.501	0.16	0.16	1.98	75	-1.61	2.46	76	-2.4	100	0.072	100	100	0.0	-0.1	48.7	48.7	82	79	80	-0.051	0.0	0.0



### Wood Heater Lab Data - ASTM E2780 / ASTM E2515

Manufacturer: <u>Hearth &amp; Home</u>	Equipment Numbers: <u>0023,00283A, 00291</u>
Model: <u>Explorer I</u>	
Tracking No.: <u>2135</u>	
Project No.: <u>061WS091E-Rev1</u>	
Run #: <u>3</u>	
Date: <u>9/30/15</u>	

**TRAIN 1 (First Hour emissions)**

Sample Component	Reagent	Filter, Probe or Dish #	Weights		
			Final, mg	Tare, mg	Particulate, mg
B. Front filter catch	Filter	C122	125.2	121.2	4.0
C. Rear filter catch	Filter	C123	112.3	112.6	-0.3
D. Probe catch*	Probe	16	114275.5	114275.1	0.4
E. Filter seals catch*	Seals	R363	4061.4	4059.8	1.6

<b>Sub-Total</b>	Total Particulate, mg:	<b>5.7</b>
------------------	------------------------	------------

**TRAIN 1 (Post First Hour Change-out)**

Sample Component	Reagent	Filter, Probe or Dish #	Weights		
			Final, mg	Tare, mg	Particulate, mg
B. Front filter catch	Filter	C124	117.0	117.0	0.0
C. Rear filter catch	Filter	C125	115.2	115.3	-0.1
D. Probe catch*	Probe	17	114569.7	114569.6	0.1
E. Filter seals catch*	Seals	R364	3319.1	3318.4	0.7

<b>Sub-Total</b>	Total Particulate, mg:	<b>0.7</b>
------------------	------------------------	------------

<b>Train 1 Aggregate</b>	Total Particulate, mg:	<b>6.4</b>
--------------------------	------------------------	------------

**TRAIN 2**

Sample Component	Reagent	Filter, Probe or Dish #	Weights		
			Final, mg	Tare, mg	Particulate, mg
A. Front filter catch	Filter	C126	125.9	121.7	4.2
B. Rear filter catch	Filter	C127	120.9	121.3	-0.4
C. Probe catch*	Probe	20	114257.5	114257.0	0.5
D. Filter seals catch*	Seals	R367	3369.0	3367.0	2.0

<b>Total Particulate, mg:</b>	<b>6.3</b>
-------------------------------	------------

**AMBIENT**

Sample Component	Reagent	Filter # or Probe #	Weights		
			Final, mg	Tare, mg	Particulate, mg
A. Front filter catch*	Filter	C121	121.5	121.3	0.2

<b>Total Particulate, mg:</b>	<b>0.2</b>
-------------------------------	------------

\*Particulate catch that results in a negative number, is assumed to be zero for probes and seals, negative numbers for filters are assumed to be part of the seal weight.

Component	Equations:
A. Front filter catch	Final (mg) - Tare (mg) = Particulate, mg
B. Rear filter catch	Final (mg) - Tare (mg) = Particulate, mg
C. Probe catch	Final (mg) - Tare (mg) = Particulate, mg

Run: 3

Manufacturer: Hearth & Home  
Model: Explorer I  
Tracking No.: 2135  
Project No.: 061WS091E-Rev1  
Test Date: 30-Sep-15

**Preburn Data**

Time	Fuel Weight	Draft	Top	Bottom	Back	Left	Right	Avg.
0	12.5	-0.05	528	257	299	534	462	
10	10.7	-0.07	618	308	254	500	432	
20	8.5	-0.07	761	340	237	510	433	
30	6.1	-0.08	834	359	246	544	458	
40	4.5	-0.07	843	374	264	583	485	
50	3.6	-0.06	780	394	298	608	507	
60	3.1	-0.05	632	421	305	604	531	
65	3	-0.05	574	428	289	582	519	478.4

### Wood Heater Test Fuel Data - ASTM E2780

Manufacturer: **Hearth & Home**  
 Model: **Explorer I**  
 Tracking No.: **2135**  
 Project No.: **0061WS091E**

Firebox Volume (ft <sup>3</sup> ):	1.67	<b>Total Fuel Weight (Dry Basis, lb):</b>	10.3	
Fuel Piece Length (in):	13	Fuel Density (lb/ft <sup>3</sup> , Dry Basis):	28.93	OK
2x4 Crib Weight (lb):	6	Loading Density (lb/ft <sup>3</sup> , Wet Basis):	7.49	OK
4x4 Crib Weight (lb):	6.5	2x4 Percentage:	48%	OK

Test Fuel Piece	Weight (lb)	Size	Readings (Dry Basis %)			Dry Weight (lb)
1	1.4	2"x 4"	22.4	23.1	22.6	1.14
2	1.7	2"x 4"	24.6	22.5	23.8	1.38
3	1.6	2"x 4"	23.8	24.3	23.1	1.29
4	2.8	4"x 4"	23.8	22.0	22.7	2.28
5	3.3	4"x 4"	21.2	26.0	23.2	2.67

Spacer Readings (Dry Basis %)			
7.3	6.1	9.6	8.4
8.0	8.0	7.9	8.5
8.4	6.8	7.4	8.4
7.3	8.4	7.6	7.8

OMNI-Test Laboratories, Inc. **ASTM E2780 Wood Heater Run Sheets**  
 Client: Hearth & Home Project Number: 061WS091E Run Number: 3  
 Model: Explorer I Tracking Number: 2135 Date: 9/24/15  
 Test Crew: B. Davis  
 OMNI Equipment ID numbers: 132, 5142132, 186, 417, 566, 428

**Wood Heater Supplemental Data**

Start Time: 10:34 Booth #: E7

Stop Time: 12:24

**Stack Gas Leak Check:**

Initial: good Final: good

**Sample Train Leak Check:**

A: 0.0 @ 6 "Hg  
 B: 0.0 @ 5 "Hg

Calibrations: Span Gas CO<sub>2</sub>: 9.76 CO: 0.993  
15.9 = 15.9 4.04 = 4.06

	Pre Test		Post Test	
	Zero	Span	Zero	Span
Time	<u>Ø</u>	<u>Ø</u>	<u>EOT</u>	<u>EOT</u>
CO <sub>2</sub>	<u>0.00</u>	<u>9.76</u>	<u>0.02</u> <u>9.74</u>	<u>9.74</u>
CO	<u>0.00</u>	<u>1.03</u>	<u>1.03</u> <u>1.03</u>	<u>1.03</u>

Air Velocity (ft/min): Initial: 250 Final: 250

Scale Audit (lbs): Initial: 10.0 Final: 10.0

Pitot Tube Leak Test: Initial: good Final: good

Stack Diameter (in): 6"

Induced Draft: 0.0

% Smoke Capture: 100%

Flue Pipe Cleaned Prior to First Test in Series:

Date: 9/24/15 Initials: BD

Tunnel Traverse		
Microtector Reading	dP (in H <sub>2</sub> O)	T(°F)
1	<u>.052</u>	<u>103</u>
2	<u>.060</u>	<u>102</u>
3	<u>.74</u>	<u>101</u>
4	<u>.059</u>	<u>100</u>
1	<u>.056</u>	<u>96</u>
2	<u>.072</u>	<u>95</u>
3	<u>.050</u>	<u>94</u>
4	<u>.048</u>	<u>93</u>
Center:		
	<u>.072</u>	<u>94</u>

	Initial	Middle	Ending
P <sub>b</sub> (in/Hg)	<u>28.48</u>	<u>28.48</u>	<u>28.48</u>
RH (%)			
Ambient (°F)	<u>77</u>	<u>82</u>	<u>81</u>

Tunnel Static Pressure (in H <sub>2</sub> O):	
Beginning of Test	End of Test
<u>-.46</u>	<u>-.46</u>

Background Filter Volume: 29.318

Technician Signature: BD

Date: 10/13/15 153

### ASTM E2780 Wood Heater Run Sheets

Client: Hearth & Home Project Number: 061WS091E Run Number: 3  
 Model: Explorer I Tracking Number: 2135 Date: 9/30/15  
 Test Crew: B. D. Davis  
 OMNI Equipment ID numbers: 566, 282

#### Wood Heater Run Notes

##### Air Control Settings

Primary:

*Sully open*

Secondary: *Fixed*

Tertiary/Pilot: *locked open*

Fan: *on High*

##### Preburn Notes

Time	Notes
<i>50</i>	<i>Raked coals</i>

##### Test Notes

Sketch test fuel configuration:

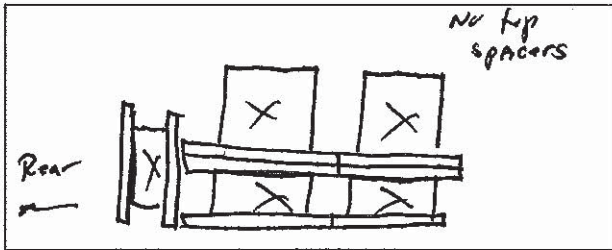

Start up procedures & Timeline:

Bypass: *NA*  
 Fuel loaded by: *40 seconds*  
 Door closed at: *50 seconds*  
 Primary air: *At test setting entire test*

Notes: *Boost Air pushed in and locked entire test*

Time	Notes
<i>0</i>	<i>Fan on High entire test</i>

Technician Signature: *B. D. Davis*

Date: *10/13/15* 154

### ASTM E2780 Wood Heater Run Sheets

Client: Hearth & Home Project Number: 061WS091E Run Number: 3  
 Model: Explorer I Tracking Number: 2135 Date: 9/30/15  
 Test Crew: D. DAVIS  
 OMNI Equipment ID numbers: 432, 296-TSY, 5742132

#### Wood Heater Fuel Data

Fuel: Douglas fir, untreated and air dried, standard grade or better dimensional lumber

Pre-Burn Fuel					
Calibration:		Cal Value (1) = 12%	Actual Reading	<u>12</u>	
		Cal Value (2) = 22%	Actual Reading	<u>22</u>	
Piece:	Length:	Reading:	Piece:	Length:	Reading:
1 <u>28</u>	<u>24</u> in	<u>22.4</u>	7	_____ in	_____
2	<u>24</u> in	<u>21.7</u>	8	_____ in	_____
3 <u>70</u>	<u>28</u> in	<u>18.6</u>	9	_____ in	_____
4	<u>23</u> in	<u>19.3</u>	10	_____ in	_____
5	<u>23</u> in	<u>19.5</u>	11	_____ in	_____
6	<u>23</u> in	<u>18.9</u>	12	_____ in	_____
<u>4 @ 13.5 @ 10.25</u>					
Total Pre-Burn Fuel Weight:		<u>12.5</u>	Pre-Burn Fuel Average Moisture: <u>20.07</u>		
Time (clock): <u>0900</u>		Room Temperature (F): <u>68</u>		Initials: <u>BD</u>	

Test Fuel							
Firebox Volume (ft <sup>3</sup> ):		<u>1.68</u>	Test Fuel Piece Length (in): <u>130</u>				
Load Weight Range (lb):		<u>10.6 - 12.9</u>	Total Wet Fuel Load Weight (lb): <u>12.5</u>				
Fuel Type & Amount: 2 x 4: <u>3</u>		4 x 4: <u>2</u>					
Weight (with spacers): <u>6</u>		Weight (with spacers): <u>6.5</u>					
Piece:	Weight (lbs):	Moisture Readings (%DB):			Fuel Type:		
1	<u>1.4</u>	<u>22.4</u>	<u>23.1</u>	<u>22.6</u>	<u>2x4</u>		
2	<u>1.7</u>	<u>26.4</u> <u>24.6</u>	<u>22.5</u>	<u>23.8</u>	<u>2x4</u>		
3	<u>1.6</u>	<u>23.8</u>	<u>24.3</u>	<u>23.1</u>	<u>2x4</u>		
4	<u>2.8</u>	<u>24.5</u> <u>23.8</u>	<u>26.8</u> <u>22.0</u>	<u>22.7</u>	<u>4x4</u>		
5	<u>3.3</u>	<u>21.2</u>	<u>26.0</u>	<u>23.2</u>	<u>4x4</u>		
6	_____	_____	_____	_____	_____		
7	_____	_____	_____	_____	_____		
Spacer Moisture Readings (%DB)							
<u>7.3</u>	<u>6.1</u>	<u>9.6</u>	<u>8.4</u>	<u>8.0</u>	<u>8.0</u>	<u>7.9</u>	<u>8.5</u>
<u>8.4</u>	<u>6.8</u>	<u>7.4</u>	<u>8.4</u>	<u>7.3</u>	<u>8.4</u>	<u>7.6</u>	<u>7.8</u>
_____	_____	_____	_____	_____	_____	_____	_____
_____	_____	_____	_____	_____	_____	_____	_____
Time (clock): <u>0900</u>		Room Temperature (F): <u>68</u>		Initials: <u>BD</u>			

Technician Signature: BD

Date: 10/13/15

VERSION: 2.2

12/14/2009

Manufacturer: Hearth & Home

Appliance Type: Non-Cat (Cat, Non

Model: Explorer I

Date: 9/30/2015

Temp. Units F (F or C)

Run: 3

Weight Units lb (kg or lb)

Control #: 0061WS091E-Rev 1

Test Duration: 115

Output Category: 4

Fuel Data

D. Fir

Wood Moisture (% wet): 18.88

HHV 19,810 kj/kg

Load Weight (lb wet): 12.50

%C 48.73

Burn Rate (dry kg/h): 2.40

%H 6.87

Total Particulate Emissions: 7.335 g

%O 43.9

%ASH 0.5

Averages

0.75

11.48

#DIV/0!

485.21

80.33

Temp. (°F)

Elapsed Time (min)

Fuel Weight Remaining (lb)

Flue Gas Composition (%)  
CO CO<sub>2</sub> O<sub>2</sub>

Flue Gas

Room Temp

Elapsed Time (min)	Fuel Weight Remaining (lb)	CO	CO <sub>2</sub>	O <sub>2</sub>	Flue Gas	Room Temp
0	12.50	0.59	6.60		379.0	77.0
5	11.80	0.43	12.90		505.0	77.0
10	10.80	0.78	17.00		619.0	77.0
15	9.70	1.07	15.72		612.0	78.0
20	8.40	1.29	16.46		642.0	79.0
25	7.40	1.12	17.00		631.0	79.0
30	6.20	1.21	17.12		652.0	80.0
35	5.10	1.82	17.50		636.0	81.0
40	4.10	1.69	16.52		622.0	81.0
45	3.30	0.84	15.34		590.0	82.0
50	2.70	0.28	13.22		553.0	82.0
55	2.30	0.18	10.72		486.0	82.0
60	2.00	0.29	9.72		456.0	82.0
65	1.70	0.31	9.24		438.0	81.0
70	1.50	0.37	9.18		433.0	81.0
75	1.30	0.49	8.84		418.0	81.0
80	1.00	0.51	8.46		404.0	81.0
85	0.90	0.70	7.82		390.0	81.0
90	0.70	0.48	8.18		376.0	81.0
95	0.60	0.50	8.00		374.0	81.0
100	0.40	0.55	7.80		369.0	81.0
105	0.20	0.66	7.88		363.0	81.0
110	0.10	0.79	7.34		354.0	81.0
115	0.00	1.04	6.90		343.0	81.0



# OMNI-Test Laboratories

**Manufacturer:** Hearth & Home  
**Model:** Explorer I  
**Date:** 09/30/15  
**Run:** 3  
**Control #:** I61WS091E-Rev 1  
**Test Duration:** 115  
**Output Category:** 4

**Technicians:** B. Davis  
 \_\_\_\_\_  
 \_\_\_\_\_  
 \_\_\_\_\_

## Test Results in Accordance with CSA B415.1-09

	HHV Basis	LHV Basis
Overall Efficiency	70.9%	76.7%
Combustion Efficiency	95.1%	95.1%
Heat Transfer Efficiency	75%	80.6%

Output Rate (kJ/h)	33,728	31,994	(Btu/h)
Burn Rate (kg/h)	2.40	5.29	(lb/h)
Input (kJ/h)	47,552	45,108	(Btu/h)

Test Load Weight (dry kg)	4.60	10.14	dry lb
MC wet (%)	18.88		
MC dry (%)	23.27		
Particulate (g )	7.335		
CO (g)	312		
Test Duration (h)	1.92		

Emissions	Particulate	CO
g/MJ Output	0.11	4.82
g/kg Dry Fuel	1.59	67.76
g/h	3.83	162.64
lb/MM Btu Output	0.26	11.21

Air/Fuel Ratio (A/F)	9.98
----------------------	------

VERSION:

2.2

12/14/2009

*Model: Explorer I  
Hearth & Home technologies  
1445 North Highway  
Colville, WA 99114*

## **Run 4**

### Wood Heater Test Results - ASTM E2780 / ASTM E2515

Manufacturer: Hearth & Home  
 Model: Explorer I  
 Project No.: 0061WS091E-Rev1  
 Tracking No.: 2135  
 Run: 4  
 Test Date: 09/30/15

Burn Rate	1.57 kg/hr dry
Average Tunnel Temperature	104 degrees Fahrenheit
Average Gas Velocity in Dilution Tunnel - vs	17.13 feet/second
Average Gas Flow Rate in Dilution Tunnel - Qsd	10543.1 dscf/hour
Average Delta p	0.078 inches H2O
Total Time of Test	180 minutes

	AMBIENT	SAMPLE TRAIN 1	SAMPLE TRAIN 2	FIRST HOUR FILTER (TRAIN 1)
Total Sample Volume - Vm	45.296 cubic feet	29.115 cubic feet	29.274 cubic feet	9.631 cubic feet
Average Gas Meter Temperature	85 degrees Fahrenheit	81 degrees Fahrenheit	82 degrees Fahrenheit	81 degrees Fahrenheit
Total Sample Volume (Standard Conditions) - Vmstd	41.493 dscf	27.240 dscf	26.958 dscf	9.011 dscf
Total Particulates - m <sub>h</sub>	0 mg	8.1 mg	6.8 mg	6.3 mg
Particulate Concentration (dry-standard) - C <sub>p</sub> /C <sub>s</sub>	0.000000 grams/dscf	0.00030 grams/dscf	0.00025 grams/dscf	0.00070 grams/dscf
Total Particulate Emissions - E <sub>T</sub>	0.00 grams	9.41 grams	7.98 grams	7.37 grams
Particulate Emission Rate	0.00 grams/hour	3.14 grams/hour	2.66 grams/hour	7.37 grams/hour
Emissions Factor		1.99 g/kg	1.69 g/kg	2.18 g/kg
Difference from Average Total Particulate Emissions		0.71 grams	0.71 grams	

**Dual Train Comparison Results Are Acceptable**

FINAL AVERAGE RESULTS	
<b>Complete Test Run</b>	
Total Particulate Emissions - E <sub>T</sub>	8.69 grams
Particulate Emission Rate	<b>2.90 grams/hour</b>
Emissions Factor	1.84 grams/kg
<b>First Hour Emissions</b>	
Total Particulate Emissions - E <sub>T</sub>	7.37 grams
Particulate Emission Rate	7.37 grams/hour
Emissions Factor	2.18 grams/kg

# Wood Heater Test Data - ASTM E2780 / ASTM E2515

Run: **4**

Manufacturer: Hearth & Home  
 Model: Explorer I  
 Tracking No.: 2135  
 Project No.: 0061WS091E-Rev1  
 Test Date: 30-Sep-15  
 Beginning Clock Time: 14:43

Total Sampling Time: 180 min  
 Recording Interval: 10 min  
 Background Sample Volume: 45,296 cubic feet  
 Meter Box Y Factor: 1.003 (1) 0.988 (2) 0.996 (Amb)

PM Control Modules: 428  
 Dilution Tunnel MW(dry): 29.00 lb/lb-mole  
 Dilution Tunnel MW(wet): 28.78 lb/lb-mole  
 Dilution Tunnel H<sub>2</sub>O: 2.00 percent  
 Dilution Tunnel Static: -0.490 "H<sub>2</sub>O  
 Tunnel Area: 0.19635 ft<sup>2</sup>  
 Pitot Tube Cp: 0.99  
 Avg. Tunnel Velocity: 17.13 ft/sec.  
 Initial Tunnel Flow: 173.8 scfm  
 Average Tunnel Flow: 175.7 scfm  
 Post-Test Leak Check (1): 0 cfm @ 6 in. Hg  
 Post-Test Leak Check (2): 0 cfm @ 4 in. Hg  
 Average Test Piece Fuel Moisture: 22.22 Dry Basis %

Velocity Traverse Data									
	Pt.1	Pt.2	Pt.3	Pt.4	Pt.5	Pt.6	Pt.7	Pt.8	Center
Initial dP	0.046	0.072	0.076	0.052	0.052	0.070	0.048	0.046	0.078
Temp:	96	96	96	96	95	95	95	94	95
	V <sub>airav</sub> 16.99		ft/sec		V <sub>cent</sub> 19.47		ft/sec		F <sub>p</sub> 0.872

Barometric Pressure: 28.45 28.44 28.43 28.44 "Hg  
 Average

OMNI Equipment Numbers: 432,565,413,5142132,132

Elapsed Time (min)	Particulate Sampling Data										Fuel Weight (lb)				Temperature Data (°F)				Stack Gas Data					
	Gas Meter 1 (ft <sup>3</sup> )	Gas Meter 2 (ft <sup>3</sup> )	Sample Rate 1 (cfm)	Sample Rate 2 (cfm)	Orifice dH1 ("H <sub>2</sub> O)	Meter 1 Temp (°F)	Meter 1 Vacuum ("Hg)	Orifice dH2 ("H <sub>2</sub> O)	Meter 2 Temp (°F)	Meter 2 Vacuum ("Hg)	Dilution Tunnel Center (°F)	Dilution Tunnel Center dP	Pro. Rate 1	Pro. Rate 2	Scale Reading	Weight Change	Avg. Slove Surface Temp	Stack	Filter 1	Filter 2	Ambient	Draft ("H <sub>2</sub> O)	CO <sub>2</sub> (%)	CO (%)
0	0.000	0.000	0.16	0.16	-0.01	76	1.6	0.01	77	1	93	0.078	100	100	12.5	0.0	361.9	227	85	84	82	-0.020	7.74	0.8
10	1.582	1.597	0.16	0.16	2.09	77	-1.81	2.46	77	-2.4	120	0.078	100	100	11.4	-1.1	377.0	605	87	88	83	-0.060	17.96	1.53
20	3.176	3.199	0.16	0.16	2.04	78	-1.83	2.44	78	-2.4	127	0.078	101	101	8.9	-2.5	434.9	604	82	85	85	-0.060	18.26	1.87
30	4.770	4.808	0.16	0.16	2.09	79	-1.91	2.50	79	-2.5	120	0.078	100	101	7.0	-1.9	455.6	534	82	85	86	-0.060	17.38	0.99
40	6.385	6.437	0.16	0.16	2.10	80	-1.91	2.52	80	-2.5	116	0.078	101	102	5.5	-1.5	458.9	472	82	86	87	-0.050	15.14	0.78
50	8.005	8.061	0.16	0.16	2.11	80	-1.9	2.47	81	-2.5	112	0.078	101	101	4.4	-1.1	457.7	442	82	86	87	-0.050	14.14	0.37
60	9.631	9.680	0.16	0.16	2.10	81	-1.9	2.46	82	-2.5	110	0.078	101	100	3.4	-1	456.9	419	82	86	88	-0.040	13.3	0.24
70	11.259	11.298	0.16	0.16	2.10	81	-1.89	2.46	82	-2.5	107	0.078	101	100	2.8	-0.6	449.4	374	82	85	87	-0.040	10.4	0.46
80	12.878	12.923	0.16	0.16	2.11	81	-1.89	2.52	83	-2.5	104	0.078	100	100	2.2	-0.6	432.5	337	82	85	87	-0.030	9.46	0.99
90	14.522	14.559	0.16	0.16	2.12	81	-1.66	2.51	83	-2.5	102	0.078	101	100	1.7	-0.5	419.3	309	85	84	87	-0.030	8.88	1.02
100	16.139	16.197	0.16	0.16	2.06	82	-1.59	2.54	83	-2.5	100	0.078	99	100	1.5	-0.2	405.8	286	80	84	86	-0.030	7.66	1.13
110	17.754	17.835	0.16	0.16	2.05	82	-1.59	2.54	83	-2.5	99	0.078	99	100	1.2	-0.3	390.0	266	78	83	86	-0.020	6.92	1.41
120	19.360	19.476	0.16	0.16	2.06	82	-1.59	2.53	83	-2.5	98	0.078	98	100	1.0	-0.2	375.6	255	77	83	86	-0.020	6.56	1.36
130	20.972	21.118	0.16	0.16	2.05	82	-1.6	2.52	83	-2.5	97	0.078	99	100	0.8	-0.2	362.9	244	76	83	85	-0.020	5.92	1.75
140	22.584	22.762	0.16	0.16	2.07	82	-1.6	2.52	83	-2.5	96	0.078	99	100	0.6	-0.2	351.1	240	75	82	85	-0.020	6.04	1.26
150	24.225	24.389	0.16	0.16	2.14	82	-1.68	2.47	83	-2.4	95	0.078	100	99	0.4	-0.2	341.7	232	75	82	85	-0.020	5.98	1.27
160	25.869	26.016	0.16	0.16	2.10	82	-1.63	2.49	83	-2.4	95	0.078	101	99	0.3	-0.1	333.9	227	74	82	84	-0.020	5.84	1.37
170	27.494	27.645	0.16	0.16	2.10	81	-1.63	2.48	83	-2.4	94	0.078	99	99	0.1	-0.2	327.0	221	74	81	84	-0.020	5.72	1.47
180	29.115	29.274	0.16	0.16	2.09	82	-1.62	2.49	83	-2.4	93	0.078	99	99	0.0	-0.1	320.5	216	74	81	84	-0.010	5.5	1.3
Avg/Tot	29.115	29.274	0.16	0.16	1.98	81	2.36	2.36	82	2.36	104	0.078	100	100	41.4	0.0	41.4	80	84	84	85	-0.033	0.0	0.0

### Wood Heater Lab Data - ASTM E2780 / ASTM E2515

Manufacturer: <u>Hearth &amp; Home</u>	Equipment Numbers: <u>0023,00283A, 00291</u>
Model: <u>Explorer I</u>	
Tracking No.: <u>2135</u>	
Project No.: <u>0061WS091E-Rev1</u>	
Run #: <u>4</u>	
Date: <u>9/30/15</u>	

**TRAIN 1 (First Hour emissions)**

Sample Component	Reagent	Filter, Probe or Dish #	Weights		
			Final, mg	Tare, mg	Particulate, mg
B. Front filter catch	Filter	C131	125.6	121.4	4.2
C. Rear filter catch	Filter	C132	121.1	120.8	0.3
D. Probe catch*	Probe	22	114351.1	114350.3	0.8
E. Filter seals catch*	Seals	R369	3288.3	3287.3	1.0

<b>Sub-Total</b>	Total Particulate, mg:	<b>6.3</b>
------------------	------------------------	------------

**TRAIN 1 (Post First Hour Change-out)**

Sample Component	Reagent	Filter, Probe or Dish #	Weights		
			Final, mg	Tare, mg	Particulate, mg
B. Front filter catch	Filter	C129	123.2	122.4	0.8
C. Rear filter catch	Filter	C130	121.8	121.7	0.1
D. Probe catch*	Probe	21	114397.4	114397.2	0.2
E. Filter seals catch*	Seals	R368	3297.4	3296.7	0.7

<b>Sub-Total</b>	Total Particulate, mg:	<b>1.8</b>
------------------	------------------------	------------

<b>Train 1 Aggregate</b>	Total Particulate, mg:	<b>8.1</b>
--------------------------	------------------------	------------

**TRAIN 2**

Sample Component	Reagent	Filter, Probe or Dish #	Weights		
			Final, mg	Tare, mg	Particulate, mg
A. Front filter catch	Filter	C133	125.8	121.2	4.6
B. Rear filter catch	Filter	C134	122.7	122.3	0.4
C. Probe catch*	Probe	23	114080.3	114079.8	0.5
D. Filter seals catch*	Seals	R370	3338.8	3337.5	1.3

<b>Total Particulate, mg:</b>	<b>6.8</b>
-------------------------------	------------

**AMBIENT**

Sample Component	Reagent	Filter # or Probe #	Weights		
			Final, mg	Tare, mg	Particulate, mg
A. Front filter catch*	Filter	C128	121.2	121.6	0.0

<b>Total Particulate, mg:</b>	<b>0.0</b>
-------------------------------	------------

\*Particulate catch that results in a negative number, is assumed to be zero for probes and seals, negative numbers for filters are assumed to be part of the seal weight.

Component	Equations:
A. Front filter catch	Final (mg) - Tare (mg) = Particulate, mg
B. Rear filter catch	Final (mg) - Tare (mg) = Particulate, mg
C. Probe catch	Final (mg) - Tare (mg) = Particulate, mg

Run: 4

Manufacturer: [Hearth & Home](#)  
Model: [Explorer I](#)  
Tracking No.: [2135](#)  
Project No.: [0061WS091E-Rev1](#)  
Test Date: [30-Sep-15](#)

**Preburn Data**

Time	Fuel Weight	Draft	Top	Bottom	Back	Left	Right	Avg.
0	6	-0.06	786	375	277	609	534	
10	5.1	-0.05	702	391	276	594	529	
20	4.4	-0.05	624	396	261	564	504	
30	3.8	-0.04	591	396	254	549	490	
40	3.6	-0.03	492	396	238	520	472	
50	3	-0.03	409	393	221	486	447	
60	2.6	-0.02	365	385	208	451	419	365.6

### Wood Heater Test Fuel Data - ASTM E2780

Manufacturer: **Hearth & Home**  
 Model: **Explorer I**  
 Tracking No.: **2135**  
 Project No.: **061WS091E-Rev-1**

Firebox Volume (ft <sup>3</sup> ):	1.68	<b>Total Fuel Weight (Dry Basis, lb):</b>	10.4	
Fuel Piece Length (in):	13	Fuel Density (lb/ft <sup>3</sup> , Dry Basis):	29.16	OK
2x4 Crib Weight (lb):	5.7	Loading Density (lb/ft <sup>3</sup> , Wet Basis):	7.44	OK
4x4 Crib Weight (lb):	6.8	2x4 Percentage:	46%	OK

Test Fuel Piece	Weight (lb)	Size	Readings (Dry Basis %)			Dry Weight (lb)
1	1.6	2"x 4"	22.7	23.1	22.8	1.30
2	1.4	2"x 4"	21.2	21.5	20.9	1.16
3	1.4	2"x 4"	23.1	23.0	22.5	1.14
4	2.8	4"x 4"	18.7	21.1	21.1	2.33
5	3.6	4"x 4"	24.7	22.5	24.4	2.91

Spacer Readings (Dry Basis %)			
7.9	8.0	7.9	7.7
7.3	7.8	6.7	6.7
7.7	8.0	7.8	7.7
7.6	8.2	7.4	7.9



### ASTM E2780 Wood Heater Run Sheets

Client: Hearth & Home Project Number: 061WS091E Run Number: 4  
 Model: Explorer I Tracking Number: 2135 Date: 9/30/15  
 Test Crew: B Davis  
 OMNI Equipment ID numbers: 132, 5142132, 186, 417, 566, 428

#### Wood Heater Supplemental Data

Start Time: 14:43 Booth #: E7

Stop Time: 17:43

**Stack Gas Leak Check:**

Initial: good Final: good

**Sample Train Leak Check:**

A: 0.0 @ 6 "Hg  
 B: 0.0 @ 4 "Hg

Calibrations: Span Gas CO<sub>2</sub>: 9.76 CO: .993

	Pre Test		Post Test	
	Zero	Span	Zero	Span
Time	<u>Ø</u>	<u>Ø</u>	<u>EOT</u>	<u>EOT</u>
CO <sub>2</sub>	<u>0.02</u>	<u>9.74</u>	<u>-0.02</u>	<u>9.72</u>
CO	<u>0.00</u>	<u>1.03</u>	<u>0.00</u>	<u>1.03</u>

Air Velocity (ft/min): Initial: 250 Final: 250

Scale Audit (lbs): Initial: 10.0 Final: 10.0

Pitot Tube Leak Test: Initial: good Final: good

Stack Diameter (in): 6"

Induced Draft: 0.0

% Smoke Capture: 100%

Flue Pipe Cleaned Prior to First Test in Series:

Date: 9/28/15 Initials: BD

	Initial	Middle	Ending
P <sub>b</sub> (in/Hg)	<u>28.45</u>	<u>28.44</u>	<u>28.43</u>
RH (%)			
Ambient (°F)	<u>82</u>	<u>87</u>	<u>84</u>

Tunnel Traverse		
Microtector Reading	dP (in H <sub>2</sub> O)	T(°F)
1	<u>.046</u>	<u>96</u>
2	<u>.072</u>	<u>96</u>
3	<u>.076</u>	<u>96</u>
4	<u>.052</u>	<u>96</u>
1	<u>.052</u>	<u>95</u>
2	<u>.070</u>	<u>95</u>
3	<u>.048</u>	<u>95</u>
4	<u>.046</u>	<u>94</u>
Center:		
	<u>.078</u>	<u>95</u>

Background Filter Volume: 45.296

Tunnel Static Pressure (in H <sub>2</sub> O):	
Beginning of Test	End of Test
<u>-.49</u>	<u>-.49</u>

Technician Signature: B Davis

Date: 10/13/15 164

Client: Hearth & Home Project Number: 061WS091E Run Number: 4  
 Model: Explorer I Tracking Number: 2135 Date: 9/30/15  
 Test Crew: B Davis  
 OMNI Equipment ID numbers: 566, 2x2

**Wood Heater Run Notes**

**Air Control Settings**

Primary:

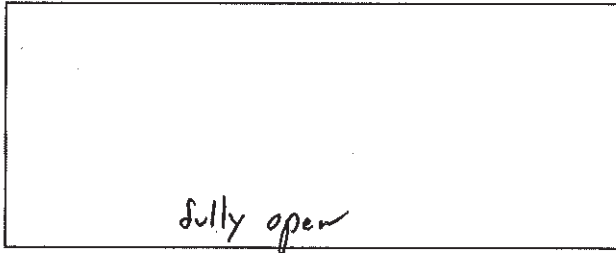

Secondary: Sixed

Tertiary/Pilot: Timed Air not used

Fan: on High

**Preburn Notes**

Time	Notes
@	45 minutes Removed 0.3 lbs

**Test Notes**

Sketch test fuel configuration:

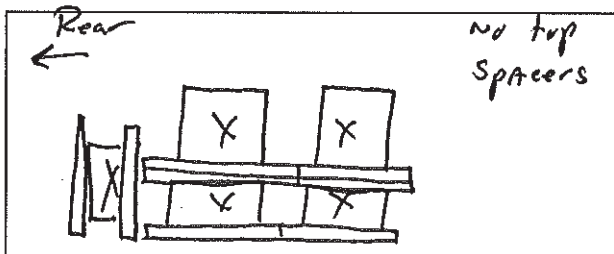

Start up procedures & Timeline:

Bypass: NA  
 Fuel loaded by: 50 seconds  
 Door closed at: 60 seconds  
 Primary air: At test setting entire test

Notes: Timed Air pushed in @ 0 minutes  
Then pulled out @ 60 seconds

Time	Notes
@	FAN turned off for first 30 minutes then turned to high

Technician Signature: B Davis

Date: 10/13/15 165

**ASTM E2780 Wood Heater Run Sheets**

Client: Hearth & Home Project Number: 061WS091E Run Number: 4  
 Model: Explorer I Tracking Number: 2135 Date: 9/30/15  
 Test Crew: B. Davis  
 OMNI Equipment ID numbers: 432, 296-T54, 5742132

**Wood Heater Fuel Data**

Fuel: Douglas fir, untreated and air dried, standard grade or better dimensional lumber

**Pre-Burn Fuel**

Calibration: Cal Value (1) = 12% Actual Reading 12  
 Cal Value (2) = 22% Actual Reading 22

Piece:	Length:	Reading:	Piece:	Length:	Reading:
1	<u>8</u> in	<u>25.3</u>	7	_____ in	_____
2	<u>8</u> in	<u>22.6</u>	8	_____ in	_____
3	<u>8</u> in	<u>19.3</u>	9	_____ in	_____
4	_____ in	_____	10	_____ in	_____
5	_____ in	_____	11	_____ in	_____
6	_____ in	_____	12	_____ in	_____

Total Pre-Burn Fuel Weight: 2.4 Pre-Burn Fuel Average Moisture: 22.40

Time (clock): 13:00 Room Temperature (F): 73 Initials: BD

**Test Fuel**

Firebox Volume (ft<sup>3</sup>): 1.68 Test Fuel Piece Length (in): 13  
 Load Weight Range (lb): 10.6 - 12.7 Total Wet Fuel Load Weight (lb): 12.5

Fuel Type & Amount: 2 x 4: 3 4 x 4: 2  
 Weight (with spacers): 5.7 Weight (with spacers): 6.8

Piece:	Weight (lbs):	Moisture Readings (%DB):		Fuel Type:
1	<u>1.6</u>	<u>22.7</u>	<u>23.1</u>	<u>2x4</u>
2	<u>1.8</u>	<u>21.2</u>	<u>21.5</u>	<u>2x4</u>
3	<u>1.4</u>	<u>23.1</u>	<u>23.0</u>	<u>2x4</u>
4	<u>2.8</u>	<u>18.7</u>	<u>21.1</u>	<u>4x4</u>
5	<u>3.6</u>	<u>24.7</u>	<u>22.5</u>	<u>4x4</u>
6	_____	_____	_____	_____
7	_____	_____	_____	_____

**Spacer Moisture Readings (%DB)**

<u>7.9</u>	<u>7.3</u>	<u>7.7</u>	<u>7.6</u>	<u>8.0</u>	<u>7.8</u>	<u>8.0</u>	<u>8.2</u>
<u>7.9</u>	<u>6.7</u>	<u>7.8</u>	<u>7.4</u>	<u>7.7</u>	<u>6.7</u>	<u>7.7</u>	<u>7.9</u>
_____	_____	_____	_____	_____	_____	_____	_____
_____	_____	_____	_____	_____	_____	_____	_____

Time (clock): 13:00 Room Temperature (F): 73 Initials: BD

VERSION: 2.2

12/14/2009

Manufacturer: Hearth & Home

Model: Explorer I

Date: 9/30/2015

Run: 4

Control #: 0061WS091E-Rev 1

Test Duration: 180

Output Category: 3

Appliance Type: Non-Cat (Cat, Non

Temp. Units F (F or C)

Weight Units lb (kg or lb)

Wood Moisture (% wet): 18.18  
 Load Weight (lb wet): 12.50  
 Burn Rate (dry kg/h): 1.55  
 Total Particulate Emissions: 8.695 g

Fuel Data

D. Fir  
 HHV 19,810 kj/kg  
 %C 48.73  
 %H 6.87  
 %O 43.9  
 %ASH 0.5

Averages 1.12 9.93 #DIV/0! 342.63 85.47  
 Temp. (°F)

Elapsed Time (min)	Fuel Weight Remaining (lb)	Flue Gas Composition (%) CO	CO <sub>2</sub>	O <sub>2</sub>	Flue Gas	Room Temp
0	12.50	0.80	7.74		227.0	82.0
10	11.40	1.53	17.96		605.0	83.0
20	8.90	1.87	18.26		604.0	85.0
30	7.00	0.99	17.38		534.0	86.0
40	5.50	0.78	15.14		472.0	87.0
50	4.40	0.37	14.14		442.0	87.0
60	3.40	0.24	13.30		419.0	88.0
70	2.80	0.46	10.40		374.0	87.0
80	2.20	0.99	9.46		337.0	87.0
90	1.70	1.02	8.68		309.0	87.0
100	1.50	1.13	7.66		286.0	86.0
110	1.20	1.41	6.92		266.0	86.0
120	1.00	1.36	6.56		255.0	86.0
130	0.80	1.75	5.92		244.0	85.0
140	0.60	1.26	6.04		240.0	85.0
150	0.40	1.27	5.98		232.0	85.0
160	0.30	1.37	5.84		227.0	84.0
170	0.10	1.47	5.72		221.0	84.0
180	0.00	1.30	5.50		216.0	84.0

# OMNI-Test Laboratories

**Manufacturer:** Hearth & Home  
**Model:** Explorer I  
**Date:** 09/30/15  
**Run:** 4  
**Control #:** I61WS091E-Rev 1  
**Test Duration:** 180  
**Output Category:** 3

**Technicians:** B. Davis  
 \_\_\_\_\_  
 \_\_\_\_\_

## Test Results in Accordance with CSA B415.1-09

	HHV Basis	LHV Basis
Overall Efficiency	72.7%	78.6%
Combustion Efficiency	93.5%	93.5%
Heat Transfer Efficiency	78%	84.0%

Output Rate (kJ/h)	22,273	21,128	(Btu/h)
Burn Rate (kg/h)	1.55	3.41	(lb/h)
Input (kJ/h)	30,642	29,068	(Btu/h)

Test Load Weight (dry kg)	4.64	10.23	dry lb
MC wet (%)	18.18		
MC dry (%)	22.22		
Particulate (g )	8.695		
CO (g)	416		
Test Duration (h)	3.00		

Emissions	Particulate	CO
g/MJ Output	0.13	6.22
g/kg Dry Fuel	1.87	89.55
g/h	2.90	138.51
lb/MM Btu Output	0.30	14.45

Air/Fuel Ratio (A/F)	11.02
----------------------	-------

VERSION:

2.2

12/14/2009

*Model: Explorer I  
Hearth & Home technologies  
1445 North Highway  
Colville, WA 99114*

## **Run 5**

### Wood Heater Test Results - ASTM E2780 / ASTM E2515

Manufacturer: Hearth & Home  
 Model: Explorer I  
 Project No.: 0061WS091E-Rev1  
 Tracking No.: 2135  
 Run: 5  
 Test Date: 10/01/15

Burn Rate	<b>0.91 kg/hr dry</b>
Average Tunnel Temperature	87 degrees Fahrenheit
Average Gas Velocity in Dilution Tunnel - vs	16.81 feet/second
Average Gas Flow Rate in Dilution Tunnel - Qsd	10674.0 dscf/hour
Average Delta p	0.076 inches H2O
Total Time of Test	280 minutes

	AMBIENT	SAMPLE TRAIN 1	SAMPLE TRAIN 2	FIRST HOUR FILTER (TRAIN 1)
Total Sample Volume - Vm	70.597 cubic feet	44.948 cubic feet	45.098 cubic feet	9.516 cubic feet
Average Gas Meter Temperature	80 degrees Fahrenheit	80 degrees Fahrenheit	81 degrees Fahrenheit	80 degrees Fahrenheit
Total Sample Volume (Standard Conditions) - Vmstd	65.395 dscf	42.147 dscf	41.593 dscf	8.923 dscf
Total Particulates - m <sub>h</sub>	0 mg	7.7 mg	6.8 mg	5.9 mg
Particulate Concentration (dry-standard) - C <sub>p</sub> /C <sub>s</sub>	0.000000 grams/dscf	0.00018 grams/dscf	0.00016 grams/dscf	0.00066 grams/dscf
Total Particulate Emissions - E <sub>T</sub>	0.00 grams	9.10 grams	8.14 grams	7.06 grams
Particulate Emission Rate	0.00 grams/hour	1.95 grams/hour	1.75 grams/hour	7.06 grams/hour
Emissions Factor		2.14 g/kg	1.91 g/kg	2.82 g/kg
Difference from Average Total Particulate Emissions		0.48 grams	0.48 grams	

**Dual Train Comparison Results Are Acceptable**

FINAL AVERAGE RESULTS	
<b>Complete Test Run</b>	
Total Particulate Emissions - E <sub>T</sub>	8.62 grams
Particulate Emission Rate	<b>1.85 grams/hour</b>
Emissions Factor	2.03 grams/kg
<b>First Hour Emissions</b>	
Total Particulate Emissions - E <sub>T</sub>	7.06 grams
Particulate Emission Rate	7.06 grams/hour
Emissions Factor	2.82 grams/kg

# Wood Heater Test Data - ASTM E2780 / ASTM E2515

Run: **5**

Manufacturer: Hearth & Home  
 Model: Explorer I  
 Tracking No.: 2135  
 Project No.: 0061WS091E-Rev1  
 Test Date: 01-Oct-15  
 Beginning Clock Time: 11:04

Total Sampling Time: 280 min  
 Recording Interval: 10 min  
 Background Sample Volume: 70.597 cubic feet  
 Meter Box Y Factor: 1.003 (1) 0.988 (2) 0.996 (Amb)

PM Control Modules: 428  
 Dilution Tunnel MW(dry): 29.00 lb/lb-mole  
 Dilution Tunnel MW(wet): 28.78 lb/lb-mole  
 Dilution Tunnel H<sub>2</sub>O: 2.00 percent  
 Dilution Tunnel Status: -0.510 "H<sub>2</sub>O  
 Tunnel Area: 0.19635 ft<sup>2</sup>  
 Pitot Tube Cp: 0.99  
 Avg. Tunnel Velocity: 16.81 ft/sec.  
 Initial Tunnel Flow: 175.9 scfm  
 Average Tunnel Flow: 177.9 scfm  
 Post-Test Leak Check (1): 0 cfm @ 3 in. Hg  
 Post-Test Leak Check (2): 0 cfm @ 5 in. Hg  
 Average Test Piece Fuel Moisture: 21.39 Dry Basis %

Velocity Traverse Data									
	Pt.1	Pt.2	Pt.3	Pt.4	Pt.5	Pt.6	Pt.7	Pt.8	Center
Initial dP	0.044	0.072	0.078	0.046	0.052	0.074	0.050	0.046	0.076
Temp: 81	81	81	81	81	81	81	81	81	81
	16.71 ft/sec V <sub>exit</sub> 18.97 ft/sec F <sub>p</sub> 0.881								

Barometric Pressure: 28.48 28.45 28.41 28.45 28.45 "Hg  
 OMNI Equipment Numbers: 432, 565, 413, 5142132, 132

Elapsed Time (min)	Particulate Sampling Data										Fuel Weight (lb)					Temperature Data (°F)					Stack Gas Data			
	Gas Meter 1 (ft <sup>3</sup> )	Gas Meter 2 (ft <sup>3</sup> )	Sample Rate 1 (cfm)	Sample Rate 2 (cfm)	Orifice dH 1 ("H <sub>2</sub> O)	Meter 1 Temp (°F)	Meter 1 Vacuum ("Hg)	Orifice dH 2 ("H <sub>2</sub> O)	Meter 2 Temp (°F)	Meter 2 Vacuum ("Hg)	Dilution Tunnel (°F)	Dilution Tunnel Center dP	Pro. Rate 1	Pro. Rate 2	Scale Reading	Weight Change	Avg. Slove Surface Temp	Stack	Filter 1	Filter 2	Ambient	Draft ("H <sub>2</sub> O)	CO <sub>2</sub> (%)	CO (%)
0	0.000	0.000	0.16	0.16	-0.01	73	1.62	0.01	74	1	80	0.076	///	///	11.1	///	353.8	185	77	77	76	-0.010	3.06	0.63
10	1.576	1.604	0.16	0.16	2.08	74	-1.55	2.46	74	-2.3	88	0.076	99	101	10.5	-0.6	355.5	405	80	77	76	-0.040	12.68	0.78
20	3.141	3.205	0.16	0.16	2.05	75	-1.56	2.47	75	-2.3	93	0.076	99	101	9.0	-1.5	401.3	466	83	79	77	-0.050	16.2	0.69
30	4.730	4.804	0.16	0.16	2.06	76	-1.53	2.44	76	-2.3	91	0.076	100	101	7.8	-1.2	424.1	400	83	80	78	-0.050	14.16	0.67
40	6.320	6.402	0.16	0.16	2.05	77	-1.53	2.46	77	-2.3	92	0.076	100	100	6.6	-1.2	439.8	414	83	80	79	-0.050	16.08	0.85
50	7.909	8.002	0.16	0.16	2.08	77	-1.56	2.46	78	-2.3	92	0.076	100	100	5.4	-1.2	460.1	412	84	81	79	-0.050	16.64	0.94
60	9.516	9.605	0.16	0.16	2.07	78	-1.56	2.49	79	-2.3	91	0.076	101	100	4.4	-1	474.3	395	85	81	80	-0.040	15.02	0.4
70	11.124	11.209	0.16	0.16	2.07	78	-1.58	2.49	79	-2.3	91	0.076	101	100	3.6	-0.8	478.6	371	80	81	81	-0.040	12.84	0.28
80	12.732	12.815	0.16	0.16	2.07	79	-1.58	2.49	80	-2.3	90	0.076	101	100	3.1	-0.5	469.4	320	81	81	81	-0.030	9.12	1.11
90	14.325	14.423	0.16	0.16	2.06	79	-1.58	2.47	80	-2.3	88	0.076	99	100	2.6	-0.5	460.4	312	82	81	81	-0.030	10.22	0.64
100	15.928	16.031	0.16	0.16	2.06	80	-1.57	2.47	81	-2.3	87	0.076	100	100	2.2	-0.4	447.1	270	82	81	80	-0.030	7.18	1.61
110	17.528	17.640	0.16	0.16	2.07	80	-1.57	2.47	82	-2.3	86	0.076	99	100	1.9	-0.3	432.0	244	82	81	80	-0.020	6.58	1.8
120	19.135	19.251	0.16	0.16	2.05	81	-1.57	2.46	82	-2.3	85	0.076	100	100	1.6	-0.3	421.8	234	82	81	80	-0.020	6.6	2
130	20.746	20.865	0.16	0.16	2.05	81	-1.57	2.46	83	-2.3	85	0.076	100	100	1.4	-0.2	412.3	223	82	81	80	-0.020	6.36	1.99
140	22.352	22.479	0.16	0.16	2.05	82	-1.57	2.47	83	-2.3	85	0.076	99	100	1.3	-0.1	403.5	219	82	81	80	-0.020	5.6	1.78
150	23.956	24.093	0.16	0.16	2.07	82	-1.57	2.47	84	-2.3	85	0.076	99	99	1.2	-0.1	395.8	210	82	81	80	-0.020	5.6	1.78
160	25.569	25.708	0.16	0.16	2.05	83	-1.57	2.45	84	-2.3	85	0.076	100	100	1.1	-0.1	388.3	204	82	82	80	-0.010	5.84	1.89
170	27.180	27.320	0.16	0.16	2.05	83	-1.57	2.48	84	-2.3	85	0.076	100	99	1.0	-0.1	381.5	204	82	82	81	-0.010	5.58	1.76
180	28.790	28.933	0.16	0.16	2.06	83	-1.57	2.45	85	-2.3	85	0.076	99	99	0.9	-0.1	374.4	199	83	82	81	-0.010	5.86	2.78
190	30.406	30.546	0.16	0.16	2.05	84	-1.57	2.45	85	-2.3	85	0.076	100	99	0.9	0	371.7	200	83	82	81	-0.010	6.54	2.51
200	32.015	32.163	0.16	0.16	2.04	84	-1.57	2.49	85	-2.3	85	0.076	99	99	0.8	-0.1	372.0	203	83	82	81	-0.010	7.22	2.16
210	33.628	33.776	0.16	0.16	2.07	83	-1.58	2.46	85	-2.3	86	0.076	100	99	0.7	-0.1	372.1	208	83	82	80	-0.010	6.68	1.64
220	35.244	35.393	0.16	0.16	2.06	81	-1.59	2.46	84	-2.3	86	0.076	100	100	0.6	-0.1	369.1	205	83	82	80	-0.010	6.38	1.77
230	36.866	37.010	0.16	0.16	2.07	80	-1.59	2.47	83	-2.3	86	0.076	101	100	0.5	-0.1	365.8	202	83	82	80	-0.010	5.7	1.78
240	38.490	38.628	0.16	0.16	2.07	79	-1.6	2.45	82	-2.3	86	0.076	101	100	0.4	-0.1	360.5	199	83	82	79	-0.010	5.6	1.83
250	40.113	40.246	0.16	0.16	2.07	79	-1.6	2.46	81	-2.3	86	0.076	101	100	0.3	-0.1	354.8	195	83	82	79	-0.010	4.78	1.89
260	41.730	41.864	0.16	0.16	2.07	79	-1.6	2.46	80	-2.3	86	0.076	101	101	0.1	-0.2	347.7	192	83	82	79	-0.010	4.44	1.72
270	43.342	43.481	0.16	0.16	2.07	78	-1.6	2.49	80	-2.3	86	0.076	101	100	0.1	0	338.9	188	83	83	79	-0.010	3.82	1.78
280	44.948	45.098	0.16	0.16	2.04	78	-1.6	2.48	80	-2.3	86	0.076	100	100	0.0	-0.1	329.6	183	83	83	79	-0.010	3.58	1.74
Avg/Tot	44.948	45.098	0.16	0.16	1.99	80	///	2.38	81	///	87	0.076	///	///	///	///	24.2	///	82	81	80	-0.022	///	///



### Wood Heater Lab Data - ASTM E2780 / ASTM E2515

Manufacturer: <u>Hearth &amp; Home</u>	Equipment Numbers: <u>0023,00283A, 00291</u>
Model: <u>Explorer I</u>	
Tracking No.: <u>2135</u>	
Project No.: <u>0061WS091E-Rev1</u>	
Run #: <u>5</u>	
Date: <u>10/1/15</u>	

**TRAIN 1 (First Hour emissions)**

Sample Component	Reagent	Filter, Probe or Dish #	Weights		
			Final, mg	Tare, mg	Particulate, mg
B. Front filter catch	Filter	C135	125.3	121.5	3.8
C. Rear filter catch	Filter	C136	124.5	124.1	0.4
D. Probe catch*	Probe	27	114283.2	114282.8	0.4
E. Filter seals catch*	Seals	R371	4141.3	4140.0	1.3

<b>Sub-Total</b>	Total Particulate, mg:	5.9
------------------	------------------------	-----

**TRAIN 1 (Post First Hour Change-out)**

Sample Component	Reagent	Filter, Probe or Dish #	Weights		
			Final, mg	Tare, mg	Particulate, mg
B. Front filter catch	Filter	C137	122.3	121.6	0.7
C. Rear filter catch	Filter	C138	120.7	120.9	-0.2
D. Probe catch*	Probe	34	115871.7	115871.4	0.3
E. Filter seals catch*	Seals	R372	3300.4	3299.4	1.0

<b>Sub-Total</b>	Total Particulate, mg:	1.8
------------------	------------------------	-----

<b>Train 1 Aggregate</b>	Total Particulate, mg:	7.7
--------------------------	------------------------	-----

**TRAIN 2**

Sample Component	Reagent	Filter, Probe or Dish #	Weights		
			Final, mg	Tare, mg	Particulate, mg
A. Front filter catch	Filter	C139	129.5	124.7	4.8
B. Rear filter catch	Filter	C140	122.0	121.6	0.4
C. Probe catch*	Probe	59	122937.7	122937.1	0.6
D. Filter seals catch*	Seals	R373	3334.4	3333.4	1.0

<b>Total Particulate, mg:</b>	<b>6.8</b>
-------------------------------	------------

**AMBIENT**

Sample Component	Reagent	Filter # or Probe #	Weights		
			Final, mg	Tare, mg	Particulate, mg
A. Front filter catch*	Filter	C141	121.2	121.3	0.0

<b>Total Particulate, mg:</b>	<b>0.0</b>
-------------------------------	------------

\*Particulate catch that results in a negative number, is assumed to be zero for probes and seals, negative numbers for filters are assumed to be part of the seal weight.

Component	Equations:
A. Front filter catch	Final (mg) - Tare (mg) = Particulate, mg
B. Rear filter catch	Final (mg) - Tare (mg) = Particulate, mg
C. Probe catch	Final (mg) - Tare (mg) = Particulate, mg

Run: 5

Manufacturer: Hearth & Home  
Model: Explorer I  
Tracking No.: 2135  
Project No.: 0061WS091E-Rev1  
Test Date: 01-Oct-15

**Preburn Data**

Time	Fuel Weight	Draft	Top	Bottom	Back	Left	Right	Avg.
0	5.1	-0.04	485	446	283	555	497	
10	4.7	-0.04	507	450	414	515	459	
20	4.1	-0.04	536	428	432	495	435	
30	3.6	-0.04	537	409	443	495	422	
40	3.3	-0.03	549	397	454	497	420	
50	3.2	-0.03	479	389	439	460	408	
60	3.1	-0.03	423	381	413	424	387	
70	2.8	-0.02	383	369	383	391	363	
80	2.7	-0.02	358	353	359	365	341	355.2

### Wood Heater Test Fuel Data - ASTM E2780

Manufacturer: **Hearth & Home**  
 Model: **Explorer I**  
 Tracking No.: **2135**  
 Project No.: **0061WS091E**

Firebox Volume (ft <sup>3</sup> ):	1.69
Fuel Piece Length (in):	13
2x4 Crib Weight (lb):	5.1
4x4 Crib Weight (lb):	6

<b>Total Fuel Weight (Dry Basis, lb):</b>	9.4	
Fuel Density (lb/ft <sup>3</sup> , Dry Basis):	25.45	OK
Loading Density (lb/ft <sup>3</sup> , Wet Basis):	6.57	OK
2x4 Percentage:	46%	OK

Test Fuel Piece	Weight (lb)	Size	Readings (Dry Basis %)			Dry Weight (lb)
1	1.4	2"x 4"	21.5	18.8	19.2	1.17
2	1.2	2"x 4"	22.7	24.4	24.6	0.97
3	1.2	2"x 4"	24.6	22.5	25.8	0.97
4	2.8	4"x 4"	20.3	19.5	18.3	2.35
5	2.7	4"x 4"	19.8	20.1	18.8	2.26

Spacer Readings (Dry Basis %)			
6.8	7.3	7.8	7.3
6.1	7.4	6.8	7.9
6.8	7.8	6.8	7.4
6.5	7.8	6.8	6.5

**ASTM E2780 Wood Heater Run Sheets**

Client: Hearth & Home Project Number: 061WS091E Run Number: 5  
 Model: Explorer I Tracking Number: 2135 Date: 10/1/15  
 Test Crew: B. Davis  
 OMNI Equipment ID numbers: 132, 5142132, 186, 417, 566, 428

**Wood Heater Supplemental Data**

Start Time: 11:04 Booth #: E7

Stop Time: 15:44

**Stack Gas Leak Check:**

Initial: good Final: good

**Sample Train Leak Check:**

A: 0.0 @ 3 "Hg  
 B: 0.0 @ 5 "Hg

Calibrations: Span Gas CO<sub>2</sub>: 9.76 CO: 0.993

	Pre Test		Post Test	
	Zero	Span	Zero	Span
Time	$\emptyset$	$\emptyset$	EOT	EOT
CO <sub>2</sub>	0.02	9.76	0.02	9.78
CO	0.00	0.99	0.00 1.00	1.00

Air Velocity (ft/min): Initial: 450 Final: 450  
 Scale Audit (lbs): Initial: 10.0 Final: 10.0  
 Pitot Tube Leak Test: Initial: good Final: good  
 Stack Diameter (in): 6"  
 Induced Draft: 0.0  
 % Smoke Capture: 100%  
 Flue Pipe Cleaned Prior to First Test in Series:  
 Date: 9/4/15 Initials: BD

Tunnel Traverse		
Microtector Reading	dP (in H <sub>2</sub> O)	T(°F)
1	.044	81
2	.072	81
3	.078	81
4	.046	81
1	.052	81
2	.074	81
3	.050	81
4	.046	81
Center:		
	.076	81

	Initial	Middle	Ending
P <sub>b</sub> (in/Hg)	28.48	28.45	28.41
RH (%)			
Ambient (°F)	76	80	79

Background Filter Volume: 70.597

Tunnel Static Pressure (in H <sub>2</sub> O):	
Beginning of Test	End of Test
- .51	- .51

255  
5.0

Technician Signature: B. Davis

Date: 10/13/15 175

Client: Hearth & Home Project Number: 061WS091E Run Number: 5  
 Model: Explorer I Tracking Number: 2135 Date: 10/1/15  
 Test Crew: B. Davis  
 OMNI Equipment ID numbers: 566, 282

Wood Heater Run Notes

Air Control Settings

Primary:

Secondary: fixed

Full closed

Tertiary/Pilot: Timed Air not used

Fan: off

Preburn Notes

Time	Notes
50	Rehad coals
60	Removed 0.4 lbs

Test Notes

Sketch test fuel configuration:

Start up procedures & Timeline:

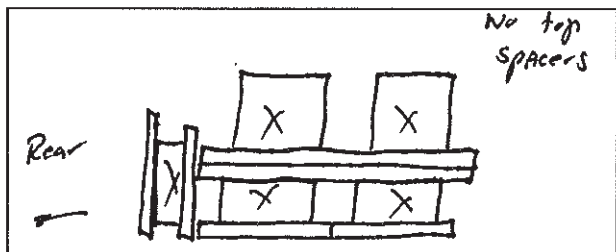

Bypass: NA  
 Fuel loaded by: 49 seconds  
 Door closed at: 60 seconds  
 Primary air: At test setting entire test

Notes: Boost Air pushed in @ 0 minutes pulled out @ 60 seconds

Time	Notes
0	FAN off for entire test

Technician Signature: B. Davis

Date: 10/13/15 176

ASTM E2780 Wood Heater Run Sheets

Client: Hearth & Home Project Number: 061WS091E Run Number: 5  
 Model: Explorer I Tracking Number: 2135 Date: 10/1/15  
 Test Crew: B DAVIS  
 OMNI Equipment ID numbers: 432, 296-TSY, 5142132

Wood Heater Fuel Data

Fuel: Douglas fir, untreated and air dried, standard grade or better dimensional lumber

**Pre-Burn Fuel**

Calibration: Cal Value (1) = 12% Actual Reading 12  
 Cal Value (2) = 22% Actual Reading 22

Piece:	Length:	Reading:	Piece:	Length:	Reading:
1	<u>8</u> in	<u>23.2</u>	7	_____ in	_____
2	<u>8</u> in	<u>24.2</u>	8	_____ in	_____
3	<u>8</u> in	<u>24.5</u>	9	_____ in	_____
4	_____ in	_____	10	_____ in	_____
5	_____ in	_____	11	_____ in	_____
6	_____ in	_____	12	_____ in	_____

Total Pre-Burn Fuel Weight: 2.4 Pre-Burn Fuel Average Moisture: 24.07  
 Time (clock): 0850 Room Temperature (F): 69 Initials: BD

**Test Fuel**

Firebox Volume (ft<sup>3</sup>): 1.68 Test Fuel Piece Length (in): 13  
 Load Weight Range (lb): 10.6-12.9 Total Wet Fuel Load Weight (lb): 11.1  
2.3 - 2.7

Fuel Type & Amount: 2 x 4: 3 4 x 4: 2  
 Weight (with spacers): 5.1 Weight (with spacers): 6.0

Piece:	Weight (lbs):	Moisture Readings (%DB):			Fuel Type:
1	<u>1.4</u>	<u>21.5</u>	<u>18.8</u>	<u>19.2</u>	<u>2x4</u>
2	<u>1.2</u>	<u>26.7</u> <u>22.7</u>	<u>23.8</u> <u>24.4</u>	<u>24.6</u> <u>24.6</u>	<u>2x4</u>
3	<u>1.2</u>	<u>24.6</u>	<u>22.5</u>	<u>25.8</u>	<u>2x4</u>
4	<u>2.8</u>	<u>20.3</u>	<u>19.5</u>	<u>18.3</u>	<u>4x4</u>
5	<u>2.7</u>	<u>19.8</u>	<u>20.1</u>	<u>18.8</u>	<u>4x4</u>
6	_____	_____	_____	_____	_____
7	_____	_____	_____	_____	_____

**Spacer Moisture Readings (%DB)**

<u>6.8</u>	<u>6.1</u>	<u>6.8</u>	<u>6.5</u>	<u>7.3</u>	<u>7.4</u>	<u>7.8</u>	<u>7.8</u>
<u>7.8</u>	<u>6.8</u>	<u>6.8</u>	<u>6.8</u>	<u>7.3</u>	<u>7.9</u>	<u>7.4</u>	<u>6.8</u>
_____	_____	_____	_____	_____	_____	_____	_____
_____	_____	_____	_____	_____	_____	_____	_____

Time (clock): 0850 Room Temperature (F): 69 Initials: BD

Technician Signature: BD

Date: 10/1/15 177

VERSION: 2.2

12/14/2009

Manufacturer: **Hearth & Home**

Appliance Type: **Non-Cat** (Cat, Non)

Model: **Explorer I**

Date: **10/1/2015**

Temp. Units **F** (F or C)

Run: **5**

Weight Units **lb** (kg or lb)

Control #: **0061WS091E-Rev 1**

Test Duration: **280**

Output Category: **2**

**Fuel Data**

**D. Fir**

Wood Moisture (% wet): **17.62**

HHV **19,810** kJ/kg

Load Weight (lb wet): **11.10**

%C **48.73**

Burn Rate (dry kg/h): **0.89**

%H **6.87**

Total Particulate Emissions: **8.62** g

%O **43.9**

%ASH **0.5**

Averages **1.49** **8.16** **#DIV/0!** **264.21** **79.55**  
Temp. (°F)

Elapsed Time (min)	Fuel Weight Remaining (lb)	Flue Gas Composition (%)			Flue Gas	Room Temp
		CO	CO <sub>2</sub>	O <sub>2</sub>		
0	11.10	0.63	3.06		185.0	76.0
10	10.50	0.78	12.68		405.0	76.0
20	9.00	0.69	16.20		466.0	77.0
30	7.80	0.67	14.16		400.0	78.0
40	6.60	0.85	16.08		414.0	79.0
50	5.40	0.94	16.64		412.0	79.0
60	4.40	0.40	15.02		395.0	80.0
70	3.60	0.28	12.84		371.0	81.0
80	3.10	1.11	9.12		320.0	81.0
90	2.60	0.64	10.22		312.0	81.0
100	2.20	1.61	7.18		270.0	80.0
110	1.90	1.80	6.58		244.0	80.0
120	1.60	2.00	6.60		234.0	80.0
130	1.40	1.86	6.24		223.0	80.0
140	1.30	1.99	6.36		219.0	80.0
150	1.20	1.78	5.60		210.0	80.0
160	1.10	1.89	5.84		204.0	80.0
170	1.00	1.76	5.58		204.0	81.0
180	0.90	2.78	5.86		199.0	81.0
190	0.90	2.51	6.54		200.0	81.0
200	0.80	2.16	7.22		203.0	81.0
210	0.70	1.64	6.68		208.0	80.0
220	0.60	1.77	6.38		205.0	80.0
230	0.50	1.78	5.70		202.0	80.0
240	0.40	1.83	5.60		199.0	79.0
250	0.30	1.89	4.78		195.0	79.0
260	0.10	1.72	4.44		192.0	79.0
270	0.10	1.78	3.82		188.0	79.0
280	0.00	1.74	3.58		183.0	79.0

# OMNI-Test Laboratories

**Manufacturer:** Hearth & Home  
**Model:** Explorer I  
**Date:** 10/01/15  
**Run:** 5  
**Control #:** I61WS091E-Rev 1  
**Test Duration:** 280  
**Output Category:** 2

**Technicians:** B. Davis  
 \_\_\_\_\_  
 \_\_\_\_\_  
 \_\_\_\_\_

## Test Results in Accordance with CSA B415.1-09

	HHV Basis	LHV Basis
Overall Efficiency	74.0%	80.0%
Combustion Efficiency	92.7%	92.7%
Heat Transfer Efficiency	80%	86.3%

Output Rate (kJ/h)	13,035	12,365	(Btu/h)
Burn Rate (kg/h)	0.89	1.96	(lb/h)
Input (kJ/h)	17,612	16,707	(Btu/h)

Test Load Weight (dry kg)	4.15	9.14	dry lb
MC wet (%)	17.62		
MC dry (%)	21.39		
Particulate (g )	8.62		
CO (g)	420		
Test Duration (h)	4.67		

Emissions	Particulate	CO
g/MJ Output	0.14	6.90
g/kg Dry Fuel	2.08	101.12
g/h	1.85	89.90
lb/MM Btu Output	0.33	16.03

Air/Fuel Ratio (A/F)	12.60
----------------------	-------

VERSION:                      2.2                      12/14/2009