

ENGINES

Parts and Accessories



KOHLER[®]
IN POWER. SINCE 1920.

Table of Contents

Central Distributors – North America3
Central Distributors – International3
Lubrication4-6
Starting7
Meters, Testers, and Special Tools8-9
Special Items10
Ignition and Electrical11-15
Guards, Screens, and Blower Housings.....16-18
Front Drive Shafts.....19
PTO20
Fuel.....21-24
Controls
(Includes coolant and lubrication alert items)25-27
Electrical Accessories.....28
Air Intake29-34
Exhaust.....35-50
Decals.....51



Kohler central distributors are listed on this page. They...and all Kohler dealers...can quickly provide the field-installed accessories in this catalog to keep your KOHLER® engines running smoothly and efficiently.

UNITED STATES

STATE/PROVINCE	KOHLER CENTRAL DISTRIBUTOR	CITY	PHONE
Arizona	Loflin Equipment Co., Inc	Phoenix	602-272-9466
California	H. G. Makelim Co.	Anaheim	650-873-4757
	H. G. Makelim Co.	S. San Francisco	650-873-4757
Colorado	H. G. Makelim Co.–Denver	Aurora	303-307-8874
Florida	Gardner of Florida, Inc.	Jacksonville	888-889-3010
Kansas	Medart–Kansas City	Edwardsville	636-282-2300
Massachusetts	Gardner-Connell	Franklin	508-543-3600
Minnesota	Central Power Distributors, Inc.	Anoka	763-576-0901
Mississippi	Medart–Tennessee/Mississippi	Olive Branch, MS	636-282-2300
Missouri	Medart–St. Louis	St. Louis	636-282-2300
Ohio	Gardner, Inc.–Ohio	Columbus	614-456-4000
Oregon	Power Equipment Systems	Salem	800-782-2700
Tennessee	Medart–Tennessee/Mississippi	Olive Branch, MS	636-282-2300
Texas	Waukesha-Pearce Industries, Inc.	Houston	713-723-1050
Virginia	Chesapeake Engine Distributors	Ashland	804-550-2231
Wisconsin	Central Power Distributors, Inc.	Menomonee Falls	262-250-1977

CANADA

British Columbia	Magneto Sales	Surrey	604-888-7240
Manitoba	Yetman's Ltd.	Winnipeg	204-586-8046
Ontario	CPT–Canada Power Technology	Mississauga	905-890-6900

INTERNATIONAL ~ Visit the Dealer Locator: www.KohlerEngines.com

Lubrication

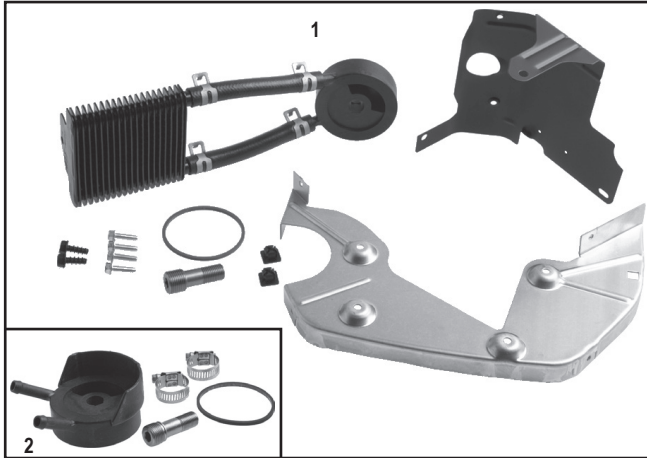

OIL COOLER KIT

To add cooler to engine. Reduces oil sump temperature up to 40°F.

Kit No.	Adapter Material	Models	Item
24 755 120-S*	Stanyl	CH/CV17-26/730-750	1
24 029 75-S Base Only	Stanyl	CH/CV17-26/730-750	2

*Increases engine width on oil filter side by 1.25" (CH twins) or 0.625" (CV twins). Possible interference fit with side mount muffler.

OIL COOLER HOSE

Part No.	Length	I.D.
24 326 17-S*	152 mm (6")	9.52 mm (3/8")
24 326 151-S	610 mm (24")	

*Includes 2 hose clamps.

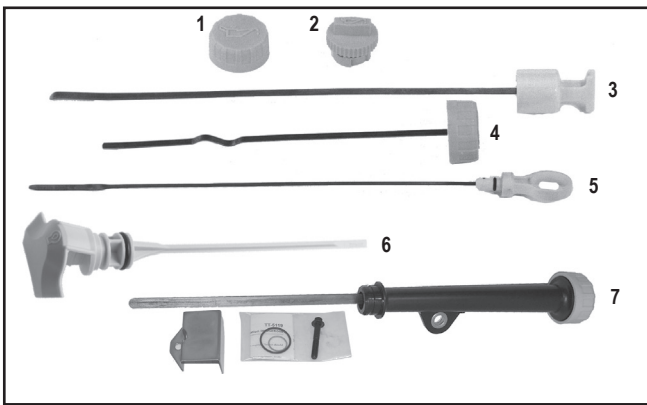

YELLOW ACCESSORIES

Part No.	Item	Models	Item
24 755 46-S*	Oil fill cap kit	CH18-26/730-750, LH640-775 ECH630-749	1
24 227 02-S**	Oil fill cap assembly	CH18-26/730-750, LH640-775	2
12 038 10-S	Dipstick, bent tube	CH11-15	3
12 038 14-S	Dipstick, straight tube	CH11-15	3
12 038 02-S	Dipstick, straight tube	CV11-16/460-493	4
24 038 04-S	Dipstick, straight tube	CV17-26/730-750, ECV630-749	4
24 038 10-S***	Dipstick, bent/straight tube	CH18-26/730-750, LH640-775	5
20 040 08-S	Dipstick, bent tube (Standard)	SV470-620	6
24 123 22-S****	Dipstick, tube kit (plastic)	CH18-26/730-750, LH640-775	7

*For valve cover with pulse-type fuel pump, not mechanical fuel pump. Includes O-ring.

**For valve cover with mechanical fuel pump. Includes O-ring.

***Used with flared tube for improved seal. Standard since Serial No. 3016800011. Earlier standard Dipstick 24 038 06-S superseded to 24 755 121-S Kit which includes the 24 038 10-S Dipstick and three Dipstick Tubes to fit all CH twin configurations.

****Can be used in place of the 1" diameter metal oil fill/dipstick tube for improved seal. Can be used with standard canister-style mufflers. Do not use on applications with crossover manifolds.

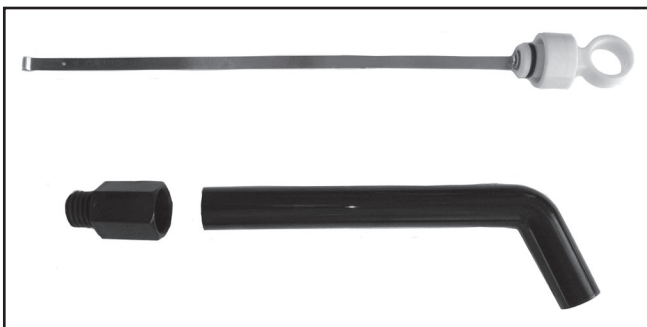

EXTENDED OIL FILL KIT

Kit No.	Models
17 755 33-S	CH270-CH440

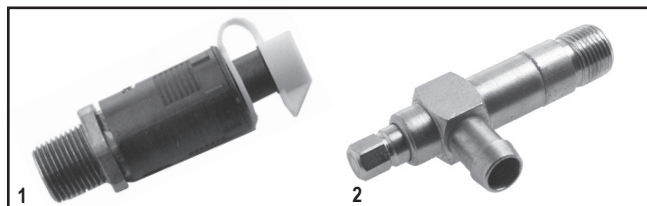

OIL DRAIN VALVE KIT

Part No.	Drain Hole	Item
25 755 14-S	3/8"-18 NPTF Includes 25 173 14-S yellow plastic cap.	1
25 462 12-S* 2"	3/8"-18 NPTF	2
25 462 13-S 3"	3/8"-18 NPTF	—

*Will not fit 824cc engine due to interference fit.

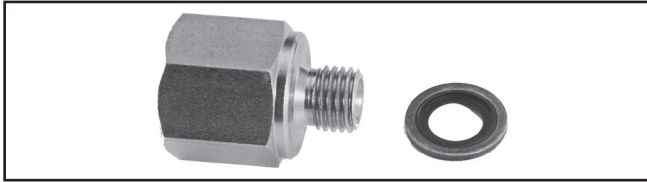

OIL DRAIN ADAPTER

For use with 25 755 14-S Oil Drain Valve Kit (3/8"-18). Includes seal.

Part No.	Thread, Engine End	Thread, Cap End	Models
63 755 10-S	M12-1.5, Male 2	3/8"-18, Female	CS8.5-12



OIL DRAIN HOSE

For use with 25 755 14-S Oil Drain Valve Kit (3/8"-18).

Part No.	Length	Thread
24 326 66-S*	12.25"	3/8"-18, Female (one end)
25 326 05-S*	28"	3/8"-18, Female (one end)

* Also order 24 294 22-S Barbed Fitting and 25 237 02-S Clamp for attaching hose to oil drain hole.

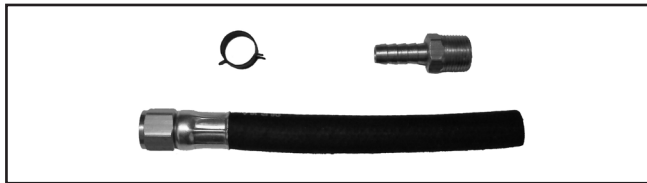

OIL DRAIN HOSE KIT

For use with 25 755 14-S Oil Drain Valve Kit (3/8"-18). Includes fitting and clamp.

Part No.	Length	Thread
24 326 152-S*	7"	3/8"-18, Female (one end)

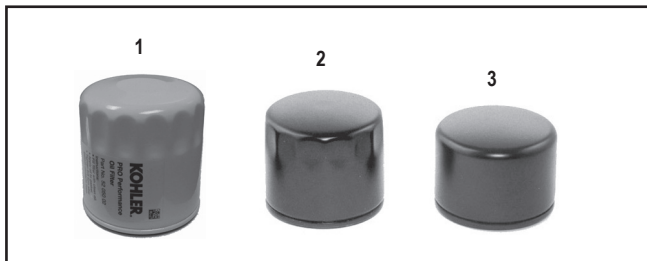

OIL FILTERS

Part No.	Height	Models	Item
52 050 02-S	3.11"	Premium filter fits PRO Series	1
12 050 01-S		Standard filter	2
28 050 01-S*	2.32"		3

*Shorter for applications with interference issues. Approximately 15% less filter capacity.

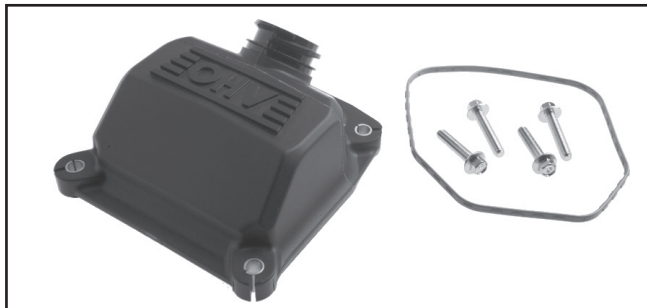

VALVE COVER WITH OIL FILL

Ideal for adding an extra oil fill location.

Part No.	Description	Models
24 755 140-S*	Valve cover with oil fill**	CH18-26/730-745, ECH630-749
66 755 10-S*	Valve cover with oil fill***	LH640-775

* Usable on either valve cover side, except for basic engines which include a mechanical fuel pump (with oil fill) in filter side valve cover.

** Also order 24 755 46-S Yellow Cap/O-ring Assembly, or 25 755 13-S Black Cap/O-ring Assembly.

***Includes yellow cap, O-ring, etc.



REMOTE OIL FILTER

Kit No.	Oil Line Length	Models
24 702 02-S*	23"	CH/CV11-16/460-493, SV470-610, CH/CV17-26, CH/CV730-750, SV710-740, ECH/ECV630-749
32 702 01-S**	12"	KT715-KT745, ZT710-ZT740, EZT740-EZT750

*Includes 12 050 01-S Filter.

**Includes 52 050 02-S Filter.

Lubrication



OIL FILTER BASE (ENGINE-MOUNTED)

Part No.	Position	Extends	Models
24 702 01-S*	Rotatable, 6 positions	3-4"	CH/CV17-22, LV625-680

* Not usable on specifications with oil cooler. Includes 12 050 01-S Filter.

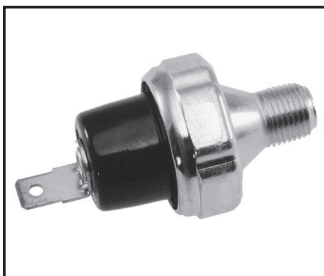

OIL PRESSURE SWITCH (OIL SENTRY™)

Available on electric start engines only.

Part No.	Circuit	PSI To Activate	Models
12 704 01-S*	Normally Closed	2-5	CH/CV11-16/460-493
52 704 01-S*	Normally Closed	2-5	CH/CV17-26/730-745, LV625-680
24 099 03-S	Normally Open	2-5	CH/CV17-26/730-745, SV810-840
25 099 27-S	Normally Closed	2-6	LH640-775 (Standard on basics)
25 099 36-S**	3-Terminal	2-10	KT715-745

*Kit includes switch, other components and instructions.

**Terminals 1 and 3 - Normally Open. Terminal 2 to Ground - Normally Closed.



OIL PRESSURE BYPASS KITS

Allows for momentary bypass of oil pressure switch when electric starter is engaged.

Part No.	Circuit	Models
82 755 25-S	Normally Closed	CH11-15*, CH/CV17-26/730-745, CH/CV940-1000, LV625-680, LH640-775, ECH/ECV630-749

* Usable on CH11-15, except with solenoid shift starter. Became standard on CH11-15 PRO electric start basics beginning with serial no. 3208409911.

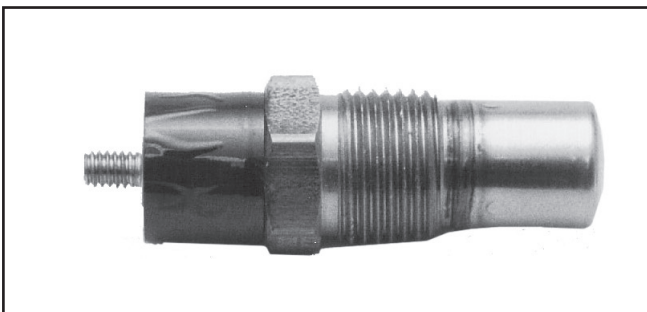

OIL TEMPERATURE SENSOR

Fits into oil drain hole to signal when temperature exceeds recommended range.

Part No.	Open	Closed	Models
24 418 01-S (standard)	310°F	350°F	CH/CV17-26*/730-745, LV625-680, LH640-775
24 418 02-S	255°F	310°F	CH/CV17-26*/730-745, LV625-680, LH640-775, ECH/ECV630-749

*On CV specifications, use on starter side only. Filter side has oil cooler.



OIL WARNING LIGHTS

Part No.	Notes	Lead Length	Models
25 352 06-S	Need 15 176 03-S harness	3"	CH5-6
25 352 10-S***	—	6.5", 9"	CH18-26/730-745, ECH/ECV630-749

ALSO SEE PAGE 25 FOR COOLANT AND LUBRICATION ALERT ITEMS.

RECOIL START KITS

Kit No.	Models	Notes
12 755 47-S	CH/CV11-16/460-493 (Shown)	For metal blower housings only.
25 312 01-S		Optional mitt grip handle for recoil starter.
12 165 04-S		Recoil starter assembly with mitt grip handle.

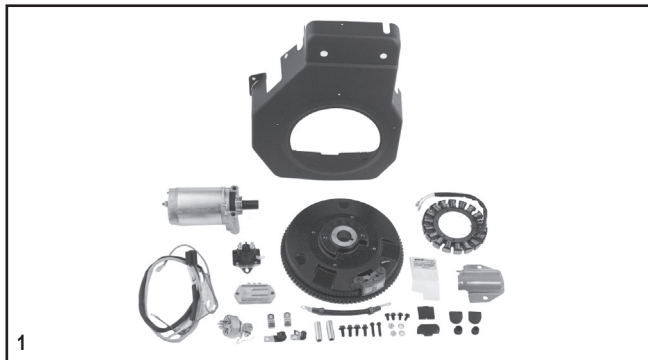
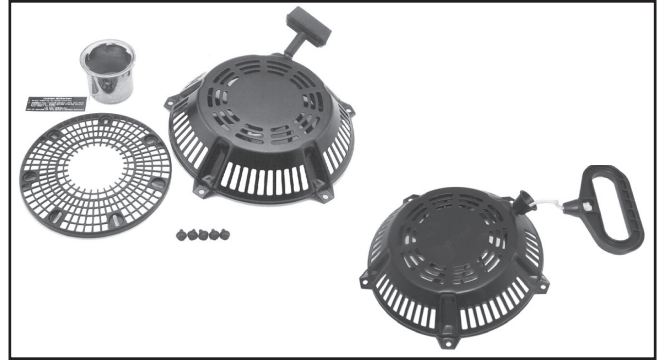

ELECTRIC START KITS

Kit No.	Models	Items
12 749 02-S	CH11-15	1
12 749 03-S	CV11-16/460-493 (Excludes wire harness which customer must supply due to variations).	-
17 755 03-S 110V	WH208	2

STARTER SOLENOIDS

Part No.	Description	Models
25 435 08-S	Internally grounded	CH/CV11-16/460-493



Meters, Testers, and Special Tools

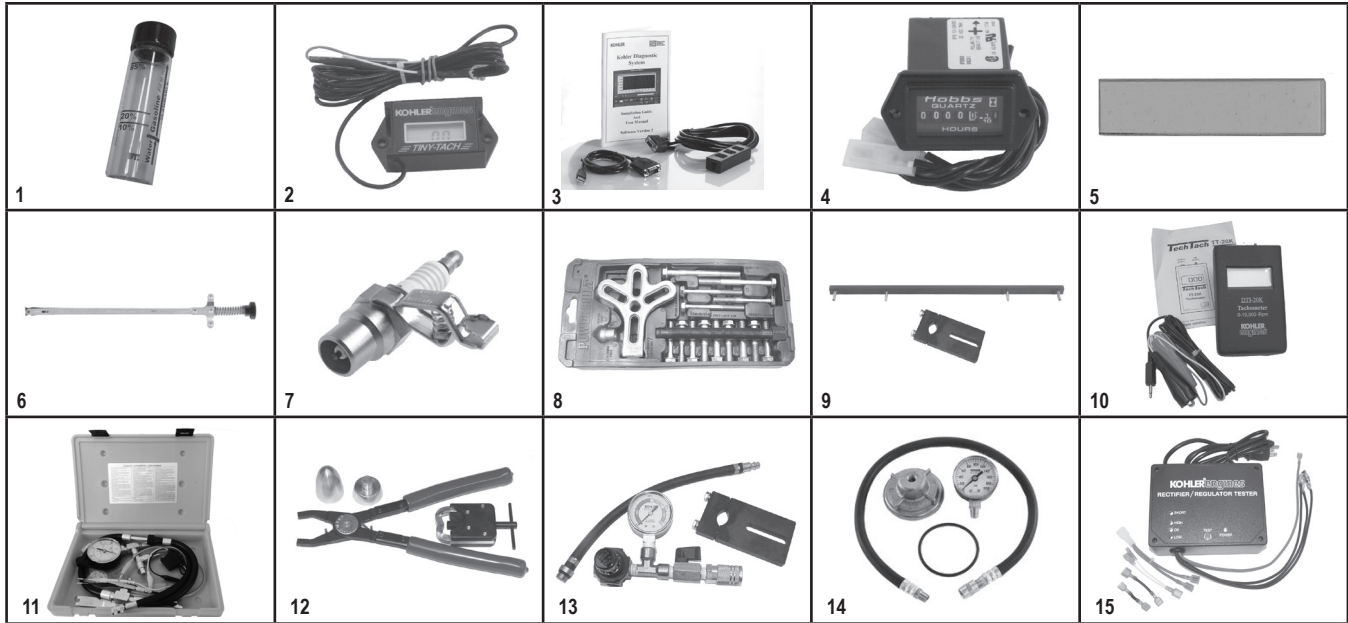

Part No.	Description	Models	Item
25 455 11-S	Alcohol Content Tester - Tests for E10/E20/E85	All	1
25 449 05-S*	Usage Meter/Tachometer (solid state)	All singles and twins	2
25 761 23-S	EFI Diagnostic Kit	All EFI	3
52 362 01-S	Hour Meter	All with electric start	4
25 455 07-S	0.060" Feeler Gauge (clear plastic for speed sensor)	Bosch EFI	5
25 761 38-S	Hydraulic Valve Lifter Tool	All with hydraulic lifters	6
25 455 01-S	Ignition Output Tester (all except capacitive discharge, fires at 12kV)	All single cylinder	7
KLR-82408**	Flywheel Puller Set	All	8
28 761 01-S	OHC Timing Tool Set (timing belt)	All OHC	9
DTI-110**	Inductive Tachometer	All except battery ignition	10
24 761 01-S	EFI Service Tool Kit (for individual components see Parts Bulletin 228)	All EFI	11
KLR-82411**	Electric Starter Service Kit	All	12
25 761 05-S	Cylinder Leakdown Tester	All	13
25 761 06-S	Oil Pressure Test Kit	All w/pressure lubrication	14
25 761 20-S	Rectifier/Regulator Tester (operates on 110-120 volt current)	All	15
25 761 41-S	Rectifier/Regulator Tester (operates on 220-240 volt current)	All	15

* Indicates when to service air cleaner, oil filter and change oil. Also serves as an hour meter and tachometer.

Service intervals are dependent upon environmental factors and not this meter alone.

** Available from Kohler-recommended tool supplier, see Parts Bulletin 228.

ALSO SEE PAGE 25 FOR COOLANT AND LUBRICATION ALERT ITEMS.

Meters, Testers, and Special Tools

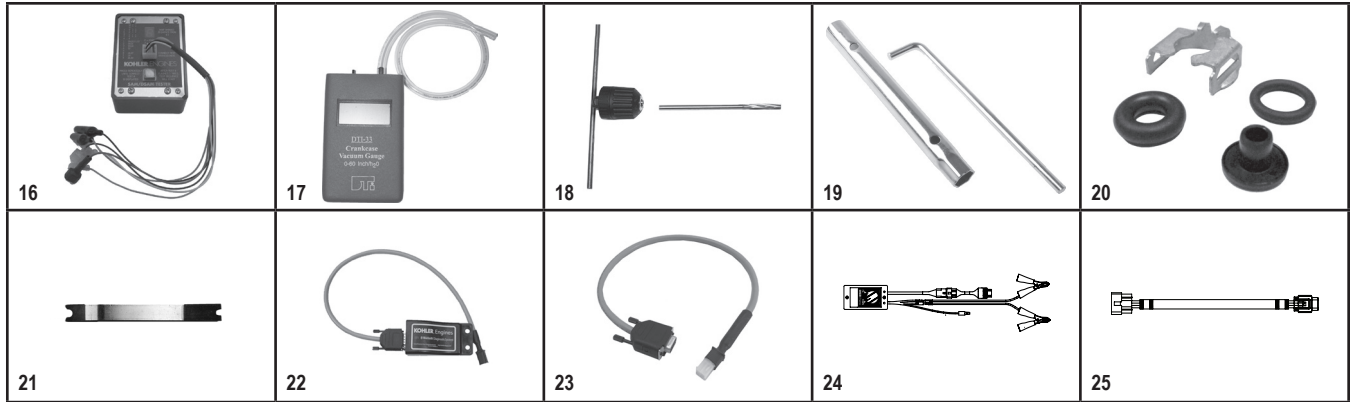

Part No.	Description	Models	Item
25 761 40-S	Spark Advance Module Tester	All w/spark advance module	16
DTI-721-01**	Vacuum/Pressure Tester	All	17
25 455 09-S	T-Handle for Valve Guide Reamer (below)	All	18
25 455 12-S	0.25 mm Oversized Reamer for Valve Guides	Command and Aegis	18
14 455 03-S	Spark Plug Tool	XT-6 and XT-7	19
25 755 41-S	Fuel Injector Tool Kit	ECH and ECV	20
25 455 20-S	Hose Removal Tool	All	21
25 761 45-S	Wireless Diagnostic Software Kit (includes module and interface cable)	All EFI	22
25 761 44-S	Wireless Diagnostic Interface Cable	All EFI	23
25 455 21-S	Stepper Motor Controller Tool (Testing operation of DLA)	All w/digital linear actuator (DLA)	24
25 518 43-S	Jumper Lead Tool (Use with 25 455 21-S to test rotary stepper motor)	All w/rotary stepper motor	25

** Available from Kohler-recommended tool supplier, see Parts Bulletin 228.

ALSO SEE PAGE 25 FOR COOLANT AND LUBRICATION ALERT ITEMS.

Special Items



1



2



3



4



5



6

OILS, SEALANTS, LUBRICANTS

Part No.	Description	Fluid Size	Item
25 357 06-S	SAE 10W-30 KOHLER [®] Oil	32 oz.	1
25 357 03-S	SAE 30 KOHLER [®] Oil	32 oz.	1
25 357 41-S	SAE 20W-50 KOHLER [®] Oil	32 oz.	1
25 357 14-S	Lubricant, Camshaft/Lifter	0.25 oz.	2
52 357 01-S	Lubricant, Inertia Drive Starter	0.25 oz.	3
25 357 12-S	Lubricant, Spline Drive	2.8 oz.	4
25 597 07-S	Sealant (Loctite [®] Instant Gasket)	4 oz.	5
25 597 05-S	Sealant (Loctite [®] 620 Retaining Compound)	0.5 ml	6
25 597 06-S	Sealant (Loctite [®] 222 Retaining Compound)	0.5 ml	6

MAINTENANCE KITS

Everything needed for periodic preventative maintenance, in a handy display pack.

Part No.	Models	Contains Air Filter
20 789 01-S	SV470-620	20 083 02-S
12 789 01-S	CV11-15	12 083 05-S
12 789 02-S	CV11-15, 460-493 PRO	12 083 10-S
24 789 01-S	CV17-23, 724-740; CH18-25, 730-740	47 083 03-S
24 789 02-S	CV18-30, 675-740; CH18-25, 730-750 PRO	24 083 03-S
24 789 03-S	CV17-27, 730-740 WAWB	45 083 02-S
25 789 01-S	CV18-25, 625-752; CH18-25, 730-752 HDAC	25 083 01-S
25 789 03-S	ECV630-749, ECH630-749	25 083 01-S
32 789 01-S	SV710-740	32 083 03-S
17 789 01-S	CH270	17 083 07-S
17 789 02-S	CH395/440	17 083 03-S
18 789 01-S	SH265	18 083 04-S
14 789 01-S	XT	14 083 01-S, 14 083 15-S, 14 083 22
16 789 01-S	ZT710-740	16 083 01-S
16 789 02-S	KT715-745, ZT710-740	16 083 04-S
32 789 02-S	KT715-745	32 083 09-S
19 789 01-S	ECV850-ECV880	25 083 01-S



BAFFLE MOUNTING

Part No.	Hardware Size
25 154 13-S	6 mm



PLASTIC NUT

Part No.	Hardware Size
25 100 37-S	6 mm



ENGINE MOUNTING SCREW

Part No.	Hardware Size	Model
25 086 672-S	3/8-16 X 1"	ZT710-740



DIODE KIT

Part No.	Specifications	Models	Item
25 755 31-S	6 AMP 1000PIV	All	1
25 755 40-S*	6 AMP 800PIV	All	2

*For electric clutch spike protection.

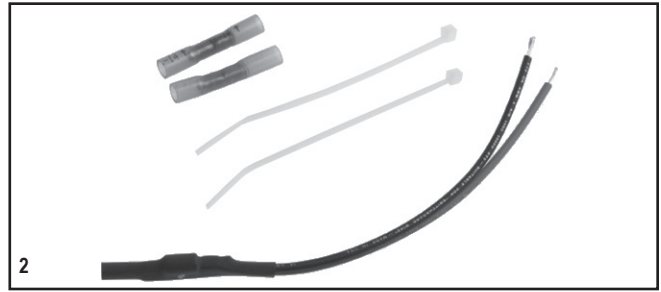

RFI/EMI CONVERSION KIT

Kit No.	Models
25 707 01-S	All CH, CV, LH, LV, SV Twins

EMC/RFI KIT

Kit No.	Models
25 755 52-S	LH775

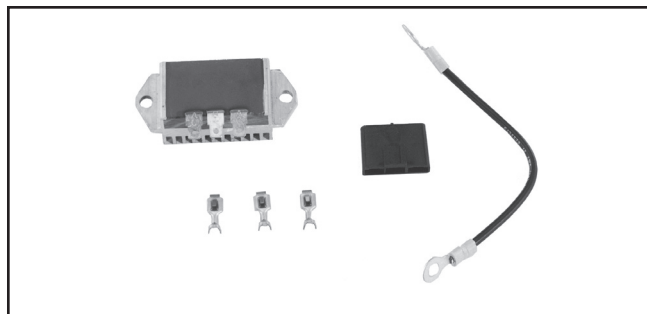

CHARGING SYSTEMS

Part No.	Description	Models
15 Amp 237878-S	Stator Kit	CH/CV11-16/460-493, SV470-620, CH/CV17-26/730-745, LH640-775, LV625-685, SV710-740
41 403 10-S	Rectifier-Regulator	All
25 Amp 28 085 02-S	Stator Kit	CH/CV11-16/460-493, SV470-620
54 755 03-S	Stator/Rectifier-Regulator Kit*	CH/CV17-26/730-745, TH520-575, LH640-775, LV625-675, SV710-740
24 755 144-S	Rectifier-Regulator Kit**(Shown)	

* Converts 15 amp system to 25 amp.

**Converts old 25 Amp Rectifier-Regulator (25 403 01-S or 25 403 04-S) to new 25 Amp Rectifier-Regulator (25 403 32-S) on all models. Includes rectifier-regulator, terminals (3), lead, connector block.



SPARK PLUGS

Part No.	Models
66 132 01-S	LH640-775, CS4-12.75 (Champion)
12 132 02-S	CH6, CH/CV11-15/460-492, CH/CV17-30/730-750, CH20-25 LP, TH520-575 LP, ECH/ECV630-749
25 132 12-S	CH/CV11-15/493 PRO, CH/CV18-30/730-750 PRO, ECH/ECV630-749 PRO
25 132 08-S	CH/CV11-15 LP
28 132 01-S	CH/CV17-25/730-740 R.F.I. with shielded metal boots
28 132 02-S	TH520-575 R.F.I.
25 132 14-S	SV470-620 R.F.I., SV710-840 R.F.I., LV625-680 R.F.I., LH640-755 R.F.I., CH/CV17-25/730-740 R.F.I. w/o metal boots
62 132 04-S	CH940-1000 R.F.I.
14 132 03-S	XT-7, SH265
14 132 11-S	XT-6, XT6.5, XT6.75
25 132 24-S	ECV850-880
25 132 19-S	CH270-440 R.F.I.
25 132 23-S	KT715-745, ZT710-740

Ignition and Electrical

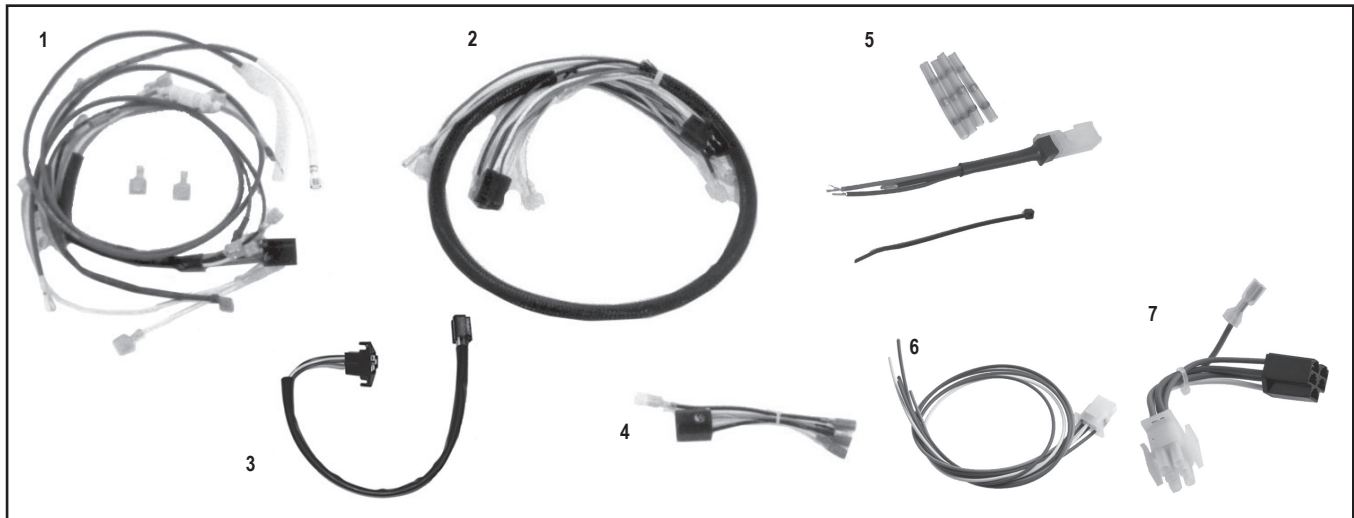

WIRING HARNESSES

Part No.	No. Leads	Lead Length	Connector	Models	Item
54 755 02-S	*	34" longest	Numerous	CH/CV17-25/730-740	1
66 176 18-S	8**	36" longest	25 155 06 (Female), 48 155 01 (Male)	LH640-755	2
25 155 07-S	5	18" all	25 155 06 (Female)	Various	3
25 155 09-S	5	18" all	25 155 06 (Female), 48 155 01 (Male)	Various	3
25 176 02-S	6***	75" longest	25 155 06 (Female), 48 155 01 (Male)	C11-16/460-493, C17-25/730-740	3
25 176 10-S	6***	75" longest	25 155 06 (Female), 48 155 01 (Male)	LH640-755, LV625-680	3
63 176 01-S	6****	5" longest	48 155 01 (Male)	CH/CV940-1000	4
24 755 155-S	*****	4" longest		CS8.5-12	5
62 176 10-S	4	30" longest	Molex #33482-0401 (Male)	All EFI	—
62 176 11-S	4	3-7/8"	Molex #33482-0401 (Male), 6 Pin Packard	CH/CV940-1000	—
24 176 160-S	5	24"	6 Pin AMP	ECH/ECV630-749	6
24 176 227-S	5	4.5"	6 Pin 25 155 06 (Female)	ECH/ECV630-749	7
24 176 161-S	4	4" (actual)	4 way black Female, 4 way black Male	ECH/ECV630-749	—
24 176 197-S	4	15" (actual)	(O2 Sensor Extension) 4 way black Female, 4 way black Male (O2 Sensor Extension)	ECH749	—

* Includes universal harness, duplex lead harness, Oil Sentry™ lead, 20 amp B+ lead, 25 amp B+ lead with Connector 25 155 03-S, (2) Terminals 15 452 10-S, and instructions.

** Can be used as a general 36" extension to basic wire harness.

*** Includes equipment ground lead for between key switch and engine block.

**** Used to create remote-mount key switch (use Key switch 25 099 37-S). Also order Harness 25 176 02-S above.

***** Pigtail harness used to replace diagnostic plug. Includes Protective Cap, 24 173 08-S.

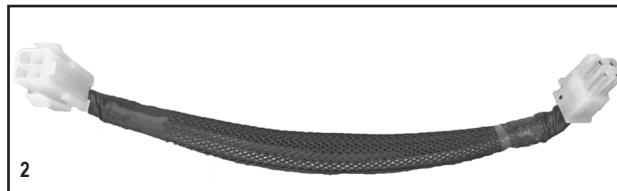

JUMPER HARNESS

Part No.	Description	Length	Item
25 176 16-S	EFI Harness Extension (similar to carburetor version 25 176 02-S)	74" overall length	1
25 176 17-S	EFI Diagnostic Harness Extension	8" overall length	2

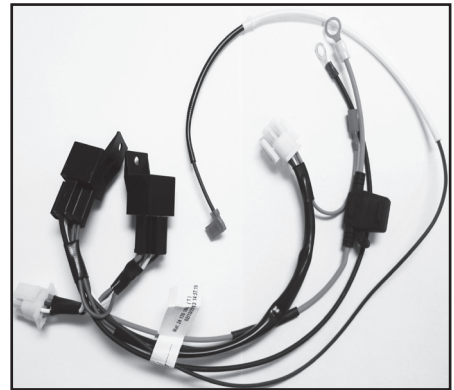
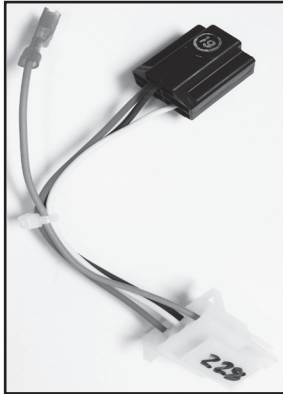
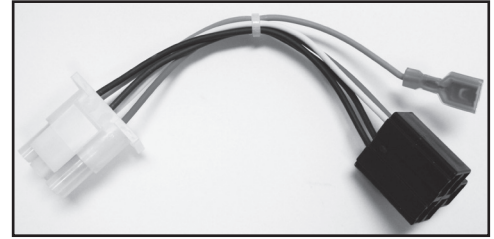
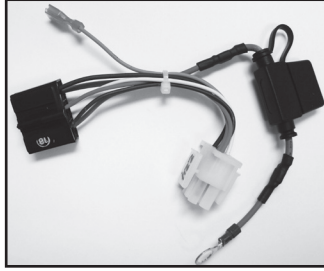
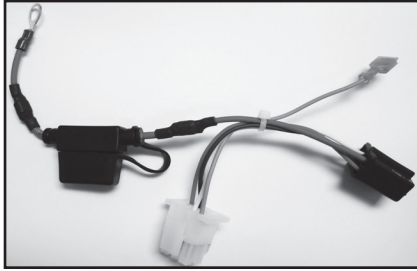

EFI JUMPER HARNESS ADAPTERS

Harness adapters have been released to make the electrical conversion when replacing a carburetor equipped Kohler® engine with a Kohler® Commercial EFI engine. Several of these new harness adapters are shown above. See Parts Bulletin 258 for more information.

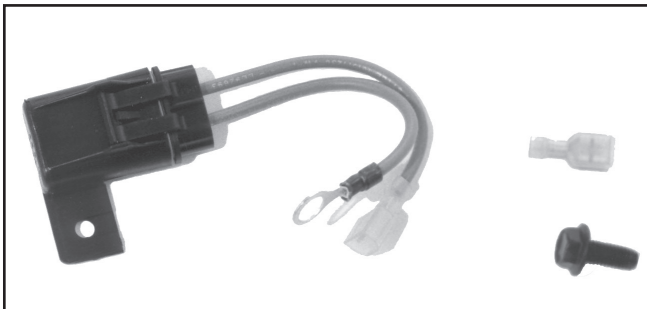

SEALED FUSE HARNESS/HOLDER

Part No.	Models
54 755 13-S	All
25 176 14-S	

Converts standard harness/fuse holder to a sealed version to prevent moisture, dirt, etc., from penetrating. Ideal for pressure washers or applications in corrosive environment. Includes 30 amp fuse.



FUSES

Part No.	Description	Models
17 304 07-S	25 AMP Fuse	CH270-440
17 304 08-S	15 AMP Fuse	CH270-440
17 304 04-S	30 AMP Fuse	CH270-440

Ignition and Electrical

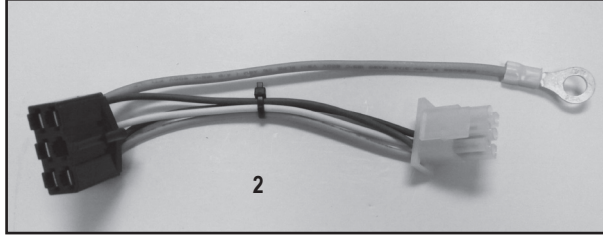
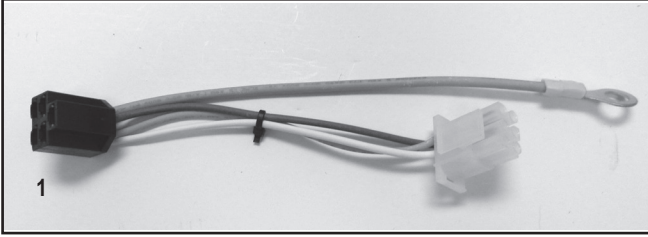

JUMPER HARNESS

Part No.	Description	Item
32 176 40-S	Confidant direct replacement for MTD Command vertical twin application	1
32 176 41-S	Confidant direct replacement for Exmark Command vertical twin application	2

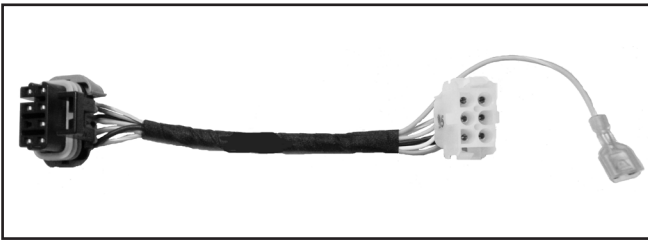

JUMPER HARNESS

Part No.	Description	Models
25 176 22-S	8 Pin Weather Pack to existing 6 Pin	ECH940, ECH980



CLIP ATTACHMENT

Part No.	Description
25 154 22-S	Clip, Attachment (Fuse Cap)

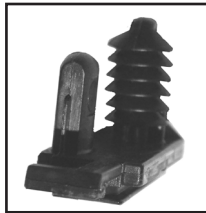

CLIP ATTACHMENT

Part No.	Description
25 154 36-S	Clip, Attachment (Fuse Cap and O2 Sensor)



FUSE CAP

Part No.	Description
25 173 50-S	Fuse Cap



GROUNDING STUD

Part No.	Model
25 072 32-S	All EFI

Ignition and Electrical

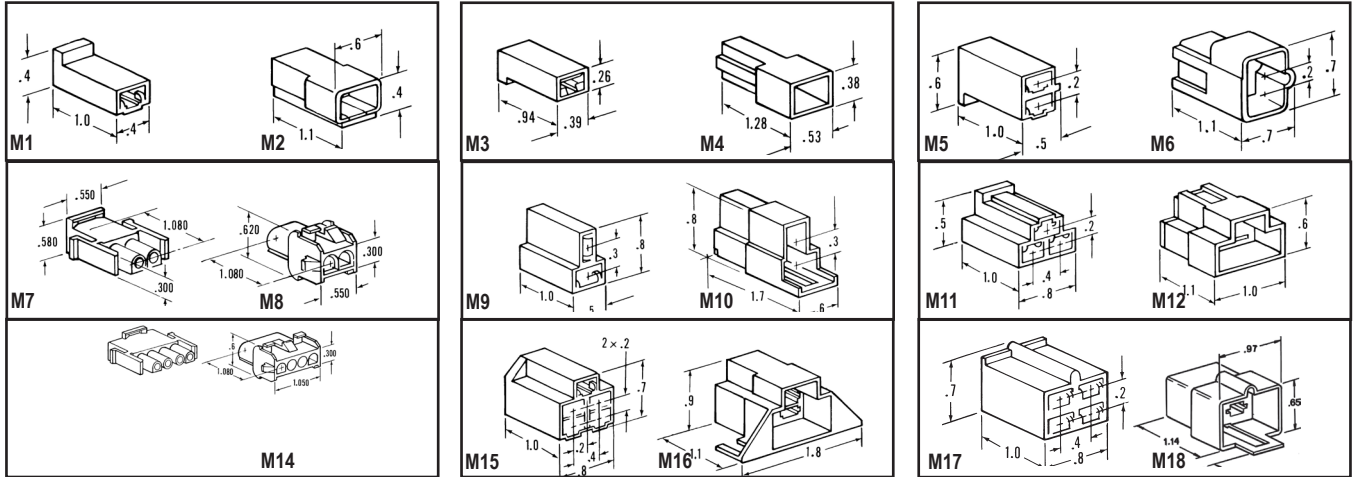

MATED (M) CONNECTORS

Description	Connector Item	Connector Part No.	Uses Female Terminal (See Below)	Connector Item	Connector Part No.	Uses Male Terminal (See Below)
1 Wire	M1	277563-S	Item 5, 6	M2	15 155 01-S	Item 4
1 Wire	M3	25 155 04-S	Item 5, 6	M4	25 155 03-S	—
2 Wire	M5	41 155 03-S	Item 5, 6	M6	52 155 04-S	Item 4
2 Wire	M7	47 155 14-S	—	M8	47 155 13-S	—
2 Wire	M9	48 155 02-S	Item 5, 6	M10	48 155 03-S	Item 4
3 Wire	M11	236473-S	Item 5, 6	M12	237088-S	Item 4
4 Wire				M14	12 155 02-S	—
5 Wire	M15	48 155 01-S	Item 5, 6	M16*	25 155 06-S	Item 4
4 Wire	M17	41 155 02-S	Item 5, 6	M18	12 155 10-S	Item 4

*Mounting screw slots on M16 are 1.328" center to center.

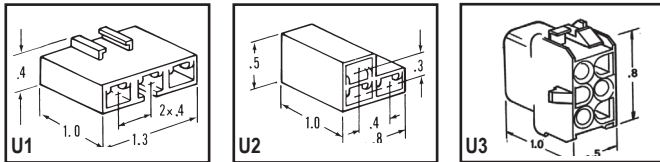

UNMATED (U) CONNECTORS

Description	Connector Part No.	Connector Item	Uses Terminal (See Below)
3 Wire	25 155 41-S	U1	Item 5, 6
3 Wire	237429-S	U2	Item 5, 6
6 Wire	12 155 09-S	U3	Item 11

TERMINALS

Size	Part No.	Type	Code	Item
3/16" Flat	25 452 11-S	F.I.F.	S	1
3/16" Flat	25 452 12-S	F.I.F.	F	2
1/4" Flat	25 452 07-S	F.I.F.	S	1
1/4" Flat	15 452 01-S	F.I.M.	S	3
1/4" Flat	52 452 01-S	L.M.	S, U	4
1/4" Flat	25 452 01-S	L.F.	S, U	5
1/4" Flat	25 452 06-S	L.F.	S, U	6
1/4" Flat	12 452 02-S	M	45°, U	7
1/8" Round	25 452 17-S	F.I.M.	S	8
12-10 AWG	25 155 45-S	B	—	9
16-14 AWG	25 155 47-S	B	—	9
20-14 AWG	25 452 25-S	L.M.	S, U	10
20-14 AWG	25 452 26-S	L.F.	S, U	11
18-14 AWG	25 452 27-S	F.I.F.	DB	12

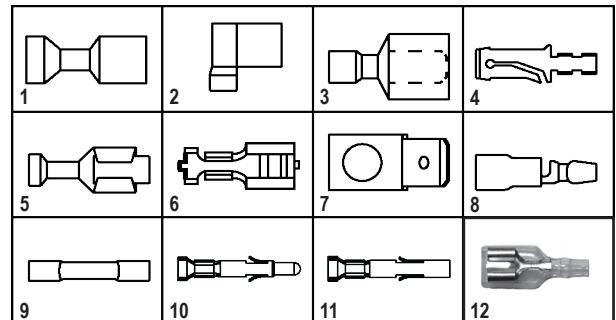

Type
 F.I.F. = Fully Insulated Female
 F.I.M. = Fully Insulated Male
 L.F. = Locking Female
 L.M. = Locking Male
 M = Male
 B = Butt Splice Connector (heat shrinkable)

Code
 S = Straight push on tab
 F = Flag push on tab
 U = Uninsulated
 DB = Double Bullet

Guards, Screens, and Blower Housings

METAL CHOPPER GRASS SCREEN KITS

Kit No.

24 755 79-S

Models

CH/CV17-26/730-745, ECH/ECV630-749

Replaces plastic screen, or can replace "crowned" metal screen on engines below Serial No. 2528418567. A new blower housing is required if replacing a plastic screen*.

Note: When installing metal screen on an "open" application, Guard Kit 24 755 94-S is required.

*Due to blower housing variations, consult Kohler factory. Based on the specification number of your engine, the corresponding blower housing can be determined.

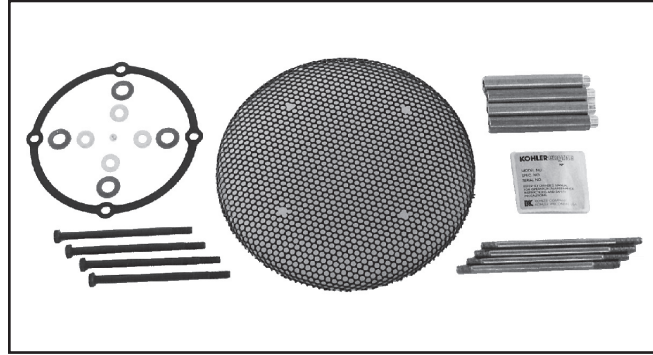

Kit No.

62 162 08-S Metal Grass Screen

Models

CH940-1000

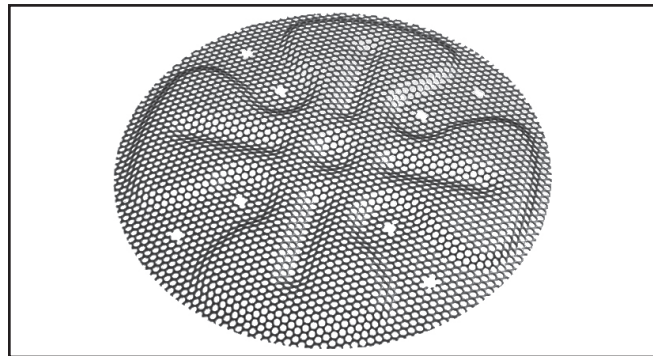

MANIFOLD COVER KITS

Kit No.

24 096 110-S

Model

CH750

Item

1

24 096 111-S

CH750 (w/front mounted controls)

2

Covers hide exposed portion of intake manifold.

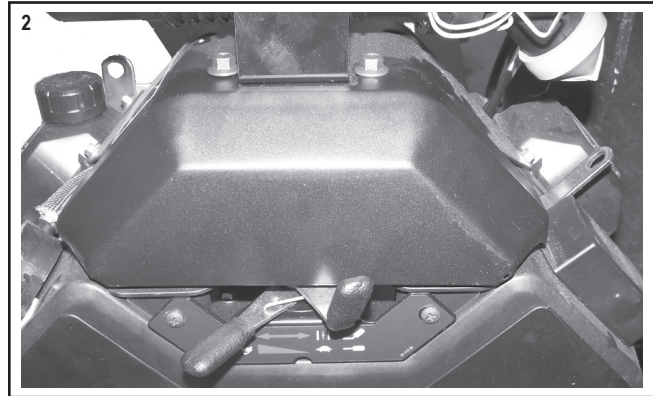
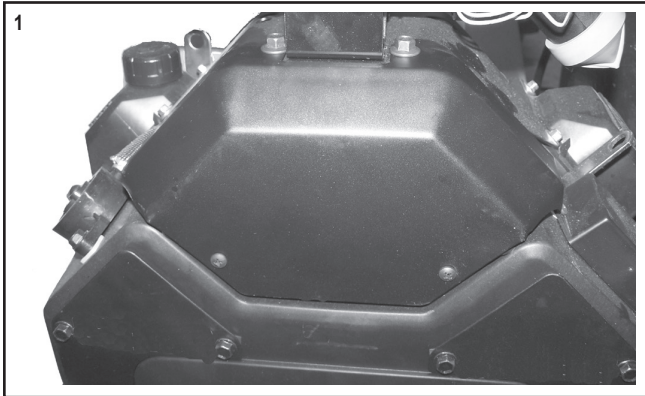

DEBRIS SCREEN

Kit No.

14 332 19-S

Model

XT

Note: Will only fit on fixed position recoil models.

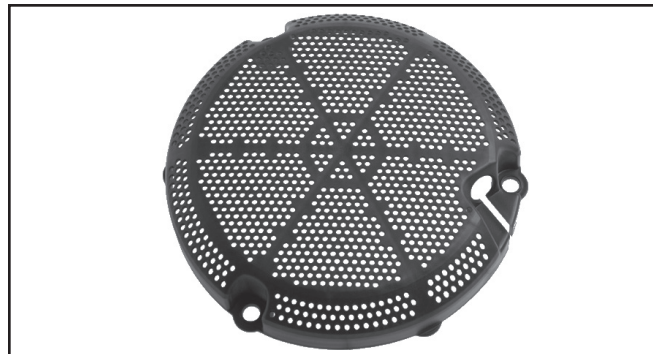

Guards, Screens, and Blower Housings

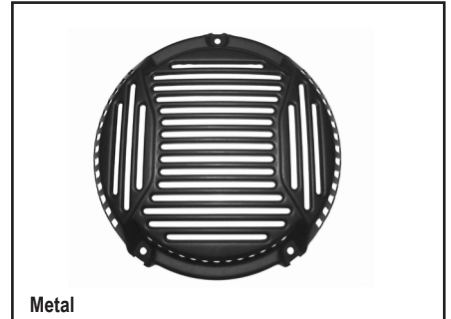
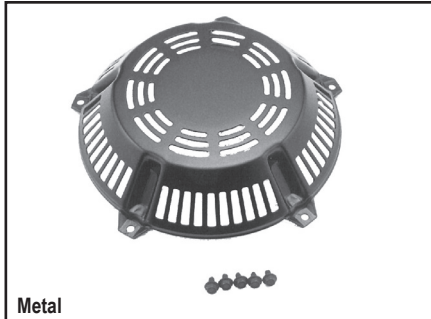
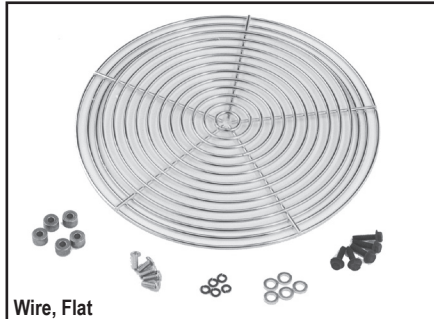
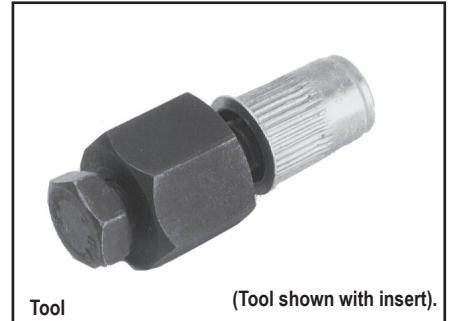
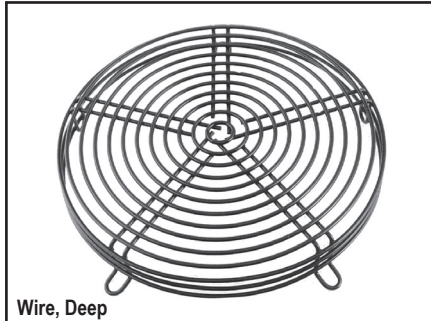
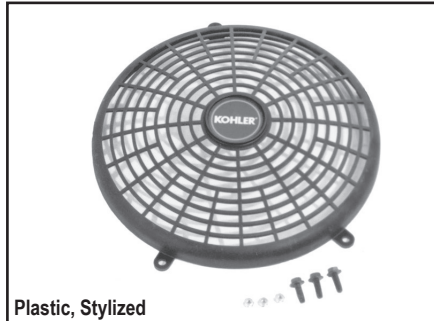

FIXED GUARDS (NOT USABLE WITH RECOIL STARTER)

Models	Plastic, Stylized	Wire, Deep	Tool	Wire, Flat	Metal
CH/CV11-16/460-493	12 755 65-S	—	—	12 755 44-S (Shown)	12 755 48-S
SV470-620	20 755 40-S, 20 755 14-S**	—	—	—	—
CH/CV17-26/730-750	24 755 81-S* (Shown)	24 755 94-S*	24 455 01-S	—	25 755 58-S****
ECV940 & ECV980	—	62 755 33-S***	—	—	25 755 58-S****
ECV650-ECV980	—	—	—	—	25 755 58-S****
ECH940-ECH980	—	—	—	—	25 755 58-S****
EZT740-EZT750	—	—	—	—	25 755 58-S****
CH940-980	—	—	—	—	25 755 58-S****

* Guard Kits 24 755 81-S and 24 755 94-S include Threaded Inserts (24 332 01-S). Insert Tool (24 455 01-S) is not included but needed to attach guard to existing blower housing. Tool is reusable. If engine has a metal grass screen, then only Guard Kit 24 755 94-S should be used. In addition, Guard 24 755 94-S is required in open applications (mowers, etc.) to protect the metal screen from potential damage.

** If original blower housing has the three bosses with holes for fixed guard mounting use 20 755 14-S Kit. If original blower housing does not have the three bosses with holes, use 20 755 40-S Blower Housing and Guard Kit.

*** For guard only, order 62 314 14-S.

**** For guard only, order 25 314 04-S.

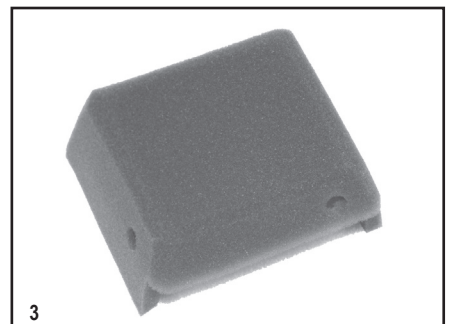

RECOIL STARTER FILTERS

Help prevent dust, dirt and debris from entering around recoil starter.

Part No.	Notes
63 755 18-S	Includes handle hole, Velcro, maintenance label and instructions.
12 050 02-S*	Includes handle hole. Conforms to shape of recoil housing when using fasteners*.
15 050 01-S**	Includes handle hole.

Models	Item
CS4-6	1
CV11-16/460-493	2
CH6	3

* For first-time usage, also order (10) 12 290 01-S Velstuds for holding the filter in place. Velstuds are reusable; they interlock with slots in starter housing.

** Also order 63 290 01-S Velcro strip (4.75" long). Cut into pieces for attachment of filter to starter housing.

Guards, Screens, and Blower Housings

BLOWER HOUSING CLEAN OUT PANELS

Kit No.	Description	Models
25 755 20-S	Matte Black Panel (2)	CH/CV17-26/730-750 ECH/ECV630-749

Allows for cleaning debris from behind blower housing and also servicing of ignition modules. Kit includes instructions/template for cutting holes in blower housing, plus panels (one with pop-out plug and label for key switch), mounting clips and screws. (Blower housing not included).



BLOWER HOUSING PLUGS

Part No.	Description	Models
24 096 17-S*	Triangular Plug (1) (Shown)	CH/CV17-26/730-750, ECH/ECV630-749
24 096 119-S**	Triangular Plug With Lip (1)	CV17-26/730-750 ECV630-749
25 139 86-S***	Plastic Plug (Shown)	

* Seals the triangular hole in the blower housing underneath the air cleaner. Two required for CH twins, one for CV twins.

** Similar to 24 096 17-S, but has an extended rubber lip. Seals the triangular hole (under the air cleaner) through which the breather hose is routed. One required.

*** Use to fill unneeded blower housing holes.

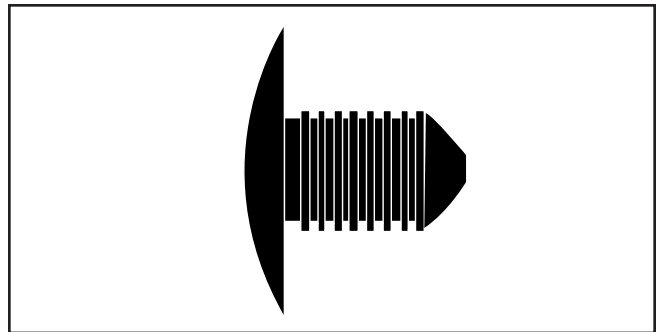

DUCTED AIR KIT

Kit No.	Description	Models
24 755 14-S	Ducted Air Kit	CH18-26/620-750



Front Drive Shafts

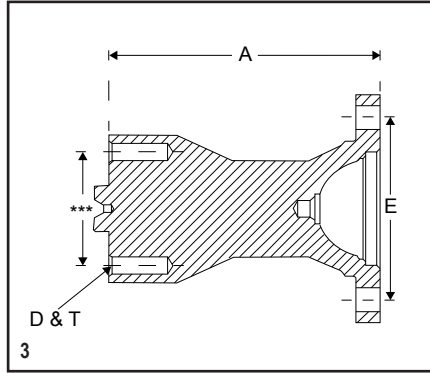
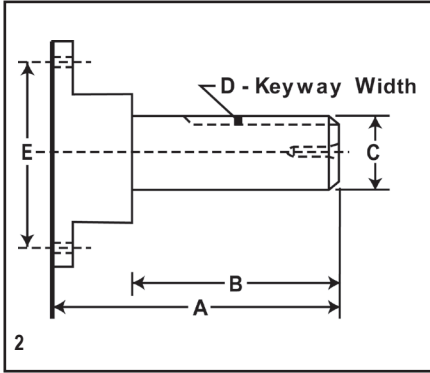

FRONT DRIVES (DIMENSIONS IN INCHES)

Part No.	A	B	C	D	E	Hardware Required	D and T	Models*
52 144 19-S	4.66	2.53	1.0	.25	3.0	See Below	3/8-16	CH11-15, LH640-775
235954-S	3.48	1.44	1.0	.25	3.0	See Below	3/8-16	CH11-15, LH640-775
237350-S	4.66	2.41	1.125	—	3.0	See Below	—	CH11-15, LH640-775
47 144 09-S	3.88	1.75	1.0	.25	3.0	See Below	7/16-20	CH11-15, LH640-775
24 755 05-S	7.00	1.44	1.0	.25	3.0	See Below	3/8-16	CH18-26/730-750, LH640-775, ECH630-749
24 755 08-S	7.00	2.53	1.0	.25	3.0	See Below	3/8-16	CH18-26/730-750, LH640-775, ECH630-749
24 144 13-S	6.40	2.53	1.0	.25	3.0	See Below	3/8-16	CH18-26/730-750, LH640-775, ECH630-749
24 144 16-S	5.35	2.53	1.0	.25	3.0	See Below	—	CH18-26/730-750, LH640-775, ECH630-749
24 144 17-S	4.00	1.93	0.7**	.188WD	3.0	See Below	—	CH18-26/730-750, LH640-775, ECH630-749
24 144 22-S	6.20	2.60	1.125	.25	3.0	See Below	—	CH18-26/730-750, LH640-775, ECH630-749
24 144 23-S	4.84	2.82	1.0	.25	3.0	See Below	3/8-16	CH18-26/730-750, LH640-775, ECH630-749
24 144 25-S	5.51	2.17	1.0	.25	3.0	See Below	—	CH18-26/730-750, LH640-775, ECH630-749
24 144 32-S	8.23	3.79	1.0	.25	3.0	See Below	M12 x 1.75	CH18-26/730-750, LH640-775, ECH630-749
24 144 51-S	5.98	2.36	1.0	.25	3.0	See Below	7/16-20	CH18-26/730-750, LH640-775, ECH630-749
24 144 53-S	4.00	1.36	1.0	.25	3.0	See Below	3/8-16	CH18-26/730-750, LH640-775, ECH630-749
28 144 05-S	5.28	3.07	1.125	.25	3.0	See Below	—	CH18-26/730-750, LH640-775, ECH630-749
66 144 04-S	3.87	2.37	1.125	.25	3.0	See Below	—	CH18-26/730-750, LH640-775, ECH630-749
62 144 07-S	4.54	2.30	1.125	.25	3.0	See Below	7/16-20	CH940-1000
62 144 09-S	5.33	2.00	1.125	.25	3.0	See Below	7/16-20	CH940-1000
24 144 55-S	4.50	1.50	1.0	.25	3.0	See Below	3/8-16	CH18-26/730-750, ECH630-749
24 144 47-S (3)	13.18	—	—	—	3.0	See Below	5/16-20	CH18-26/730-750, LH640-775, ECH630-749

* Consult factory on: **CH11-15** since flywheel holes may vary and specification may not accept front drive: **LH640-775** to verify front loading.

** Threaded end (3/4"-16 UNF-2A).

*** Bolt Circle Diameter 47.62

WD = Woodruff Key

Required Hardware:

CH11-15: (2) X-22-2-S Washer, (2) M10x30mm-1.5 socket head screw purchased locally

CH18-26/730-750 and ECH630-749: (4) M-839025-S Screw (Included in -755 kits)

LH640-775: (4) M-839025-S Screw

CH940-1000: (4) M-839035-S Screw

SOME FRONT DRIVES REQUIRE:

LH640-775: Also order 66 096 18-S Flywheel Cover w/ hole for front drive or Instruction Sheet TT-5081 for a template to cut the hole in your existing flywheel cover.

All other models: Also order Grass Screen w/hole for front drive per table below. If changing from plastic screen to metal screen, also order blower housing. Contact customer service at factory for correct blower housing.

Grass Screen

Part No.	Type	Hole Diameter (In.)	Hardware Required To Attach New Screen	Models
12 162 03-S	Plastic	2.56	None	CH11-15
24 755 171-S	Plastic	1.42	(4) M-639016-S Screw, (4) 12 112 01-S Spacer	CH18-22
24 162 45-S	Plastic, Hi-Eff.	1.77	None	CH18-26/730-750
24 162 38-S	Metal*, Flat	1.57	None*	CH18-26/730-750
24 162 39-S	Metal*, Flat	2.95	None*	CH18-26/730-750
24 162 40-S	Metal*, Flat	2.46	None*	CH18-26/730-750
62 162 09-S	Metal	1.81	None	CH940-1000

*Flat design. If replacing older "crowned" version, also order 54 755 10-S Hardware Kit.

PTO

CRANKSHAFT SPLINE INSERT KIT

Kit No.
82 755 02-S
25 755 27-S
48 755 21-S

Number of Teeth
9
11
13

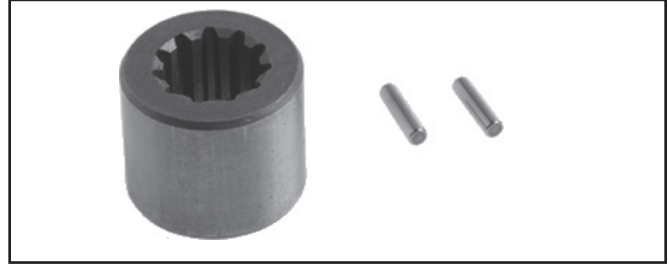

CRANKSHAFT PTO KEY

Part No.
25 340 05-S
25 340 06-S

Description
Fits 3/16" keyway
Fits 1/4" keyway

Models
CS4, CS6, CH270, SH265
CH395, CH440, CS8.5, CS10, CS12

FUEL FILTERS

Part No.	Inlet Hose		Shell Length	Models
	I.D.	Micron		
25 050 21-S	1/4"	75	2.13"	Standard: CH/CV11-15/493
24 050 13-S	9/32", 1/4"	9-12	2.35"	Standard: CH/CV17-25/730-740, 750, 940-1000, LV625-680, LH640-755, SV470-620, SV710-840
24 050 03-S	5/16"	8-10	5.51"	Standard: All EFI (metal, high pressure, extended life filter)
24 050 22-S	3/8"	80	1.60"	Standard: All EFI (plastic, low pressure, between fuel tank and fuel pump)
25 050 07-S	3/16, 1/4"	75	1.0"	Standard: XT-7, CH/CV11-16/460-492 non-PRO (electric start)
25 050 22-S	1/4"	51	2.13"	Standard: CH/CV11-15/493 (fuel pump fed fuel)
25 050 42-S	5/16"	10	1.56"	Standard: ECH630-749/ECV630-749
14 050 14-S	1/4"	110	2.40"	Standard: XT, WH208 (in-nipple filter)
17 050 17-S	1/4"	60	1.60"	Standard: CH270-440

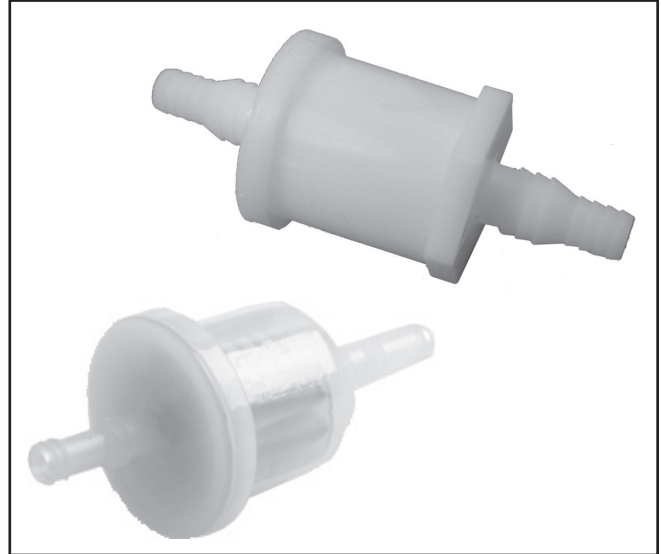

LOW PERMEATION FUEL LINE

Part No.	I.D.	Length	Model
25 111 81-S	1/4"	39"	All except EFI
25 111 39-S	1/4"	25' (bulk roll)	All except EFI
25 111 37-S	5/16"	5'	EFI Only
25 111 69-S	1/4"	11"	XT

ALCOHOL CONTENT TESTER

Part No.	Description
25 455 11-S	Tests for E10/E20/E85



INLINE FUEL SHUT-OFF VALVE

Part No.	Description
17 099 25-S	- Fits all 1/4" fuel lines



Fuel

FUEL TANK KIT

Kit No.	Tank Mounting	Tank Material	Tank Capacity (Gal.)	Includes Cap	Models
12 760 01-S	Engine	Plastic	1.25	25 173 20-S	CH11-15



FUEL TANK CAPS

Item	Part No.	Gauge in Cap	Fits
1	25 173 04-S	Yes	Voided 52 755 45 remote metal tank
1	25 173 21-S	Yes	Voided 52 755 79 remote plastic tank
2	25 173 22-S	No	25 755 35 remote plastic tank
3	25 173 20-S	No	CH11-15
4	14 227 11-S	No	XT-7
5	14 227 16-S	No	XT-6/7
6	17 173 25-S	No	CH270-440, SH265
7	17 173 19-S	No	CH270-440, SH265 (evaporative emission version)

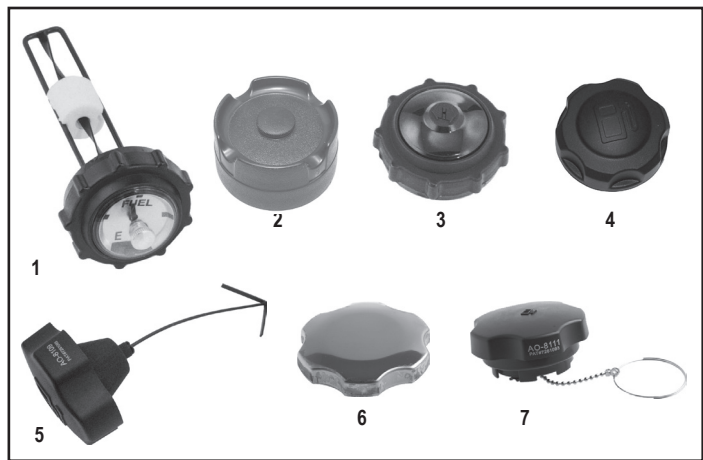

CARBON CANISTER KIT

Kit No.	Description	Quantity	Item
25 755 38-S	Carbon Canister Kit (5 gallon)	1	—
INCLUDES:			
14 237 05-S	Hose Clamp	2	1
25 050 39-S	Carbon Canister Filter	1	2
25 237 24-S	Hose Clamp	4	3
25 313 04-S	Roll-over Valve Grommet	1	4
25 326 08-S	SAI Control Hose	1	5
25 462 17-S	Roll-over Valve	1	6
25 326 23-S	Evaporative Hose (144" Length)	1	7
TT-5215	Installation Instruction	1	—

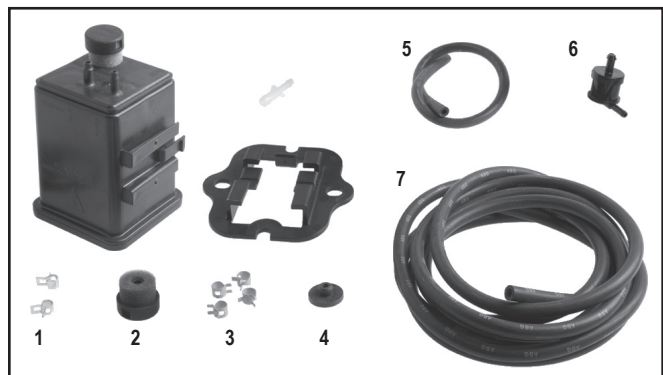



SLEEVES

Part No.	Description	ID	Length	MAX Operating Temperature	Item
25 431 35-S	Heat Reflective Sleeve (aluminum laminated fiberglass tube)	0.625"	13.5"	392°F	1
25 431 32-S	Anti-Abrasion Sleeve	0.25-0.75"	21"	—	2

ELECTRIC FUEL PUMP

Kit No.	Models	P.S.I. at 0 Delivery	Self-Prime Lift	Total Column
25 559 01-S	All except CH6, CS, and Bosch EFI	0.5-2.0	12"	6'

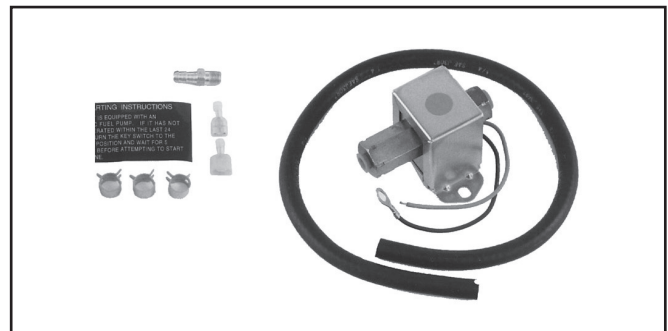

EFI ELECTRIC FUEL PUMP - HIGH PRESSURE

Part No	Models	P.S.I	G.P.H.	AMPS Max
24 393 52-S	Bosch EFI	50	15.0	5.0



Fuel

AIR TEMPERATURE SENSOR GROMMET

Part No. 25 313 07-S
Models ECH/ECV630-749



PULSE FUEL PUMP

Part No. 24 393 16-S
Models CH/CV17-25/730-740, LV625-675,
 ECH/ECV630-749, SV470-840,
 KT715-745, ZT710-740, ECV850-880

Item
1

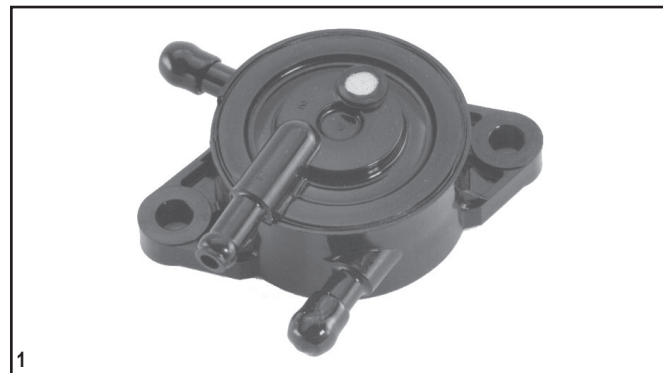

MECHANICAL FUEL PUMPS

Part No. (Non-Metallic)	Models	Item
12 559 02-S	CH/CV11-16/460-493	1
24 559 10-S*	CH18-25/730-740	2
62 559 01-S***	CH940-1000	3

* Integral valve cover. For #2 cylinder side (oil filter side) only. For engines below Serial No. 2520800017, also order Valve Train Kit 24 755 66-S to convert to compatible rocker arms.

** Fittings include O-ring.

*** Integral valve cover. For #2 cylinder side (oil filter side) only.

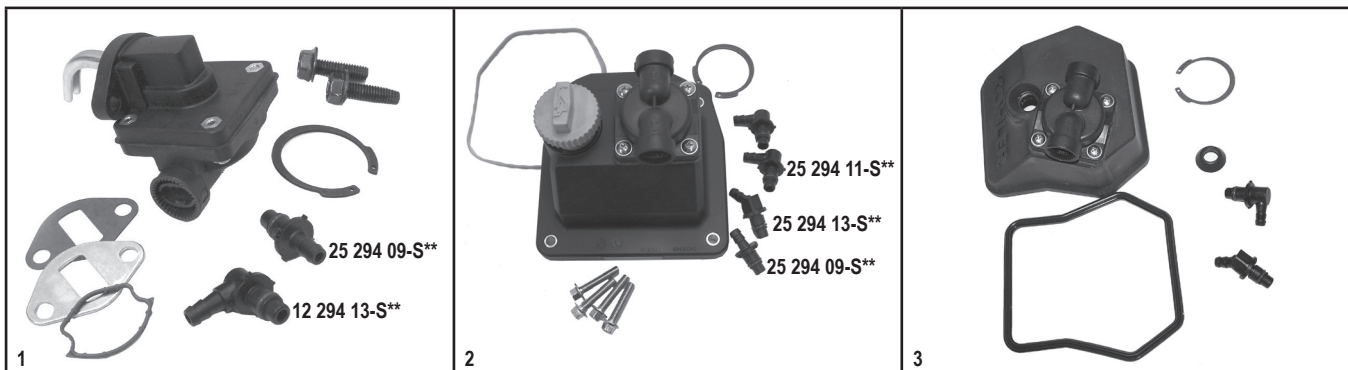

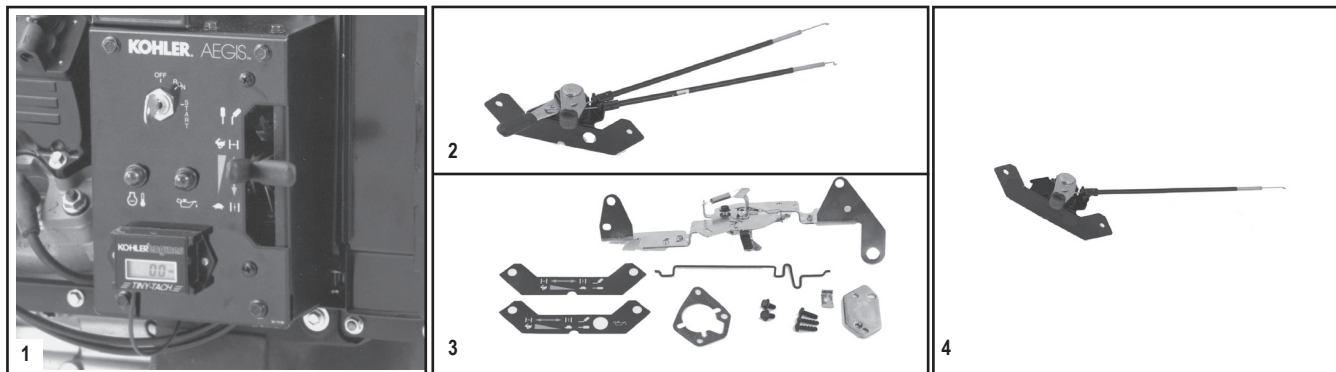

ENGINE-MOUNTED CONTROL PANELS

Kit No.	Mounting Location	Major Components	Models	Item
66 755 09-S*	Filter Side (only)	Panel, key switch, choke, throttle, low oil light, harness	LH640-755	1
24 225 08-S**	Front Side	Bracket, levers, cable assembly	CH18-26/730-745	2
24 755 106-S**	Front Side	Panel, choke, throttle (includes item 2)	CH18-26/730-745	3
62 376 02-S	Front Side	Panel, key switch, indicator light, choke/throttle brackets	CH940-1000	—
24 225 13-S	Front Side	Bracket, lever, cable assembly	ECH630-749	4
62 378 01-S	Front Side	Panel, key switch, indicator light, harness	ECH940-ECH980	—

* Shown with optional additional items: Coolant Temperature Gauge and Coolant Temperature Light (only one may be used), and Tiny Tach/Hourmeter.

** For installation of lever-type throttle/choke which became standard since Serial No. 3009400011. Also order Air Cleaner Cover 24 096 26-S if adding controls to non-panel engine specification. Also needs Bracket 24 126 99-S (1), Screw M-545010-S (2), Decal 24 113 92-S, and Screw 24 086 06-S (2).

COOLANT ITEMS

Kit No.	Description	Models
66 755 12-S*	Light, Coolant Temperature	LH640-775

* Includes light/wiring, temperature switch.



LUBRICATION ITEMS

Kit No.	Description	Models
25 352 10-S**	Light, Oil Warning	CH18-26/730-745

** Includes light, 6.5" and 9" leads, fits in control panels shown above.

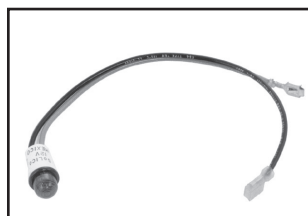

THERMOSTAT

Gasket included.

Kit No.	Description	Models
66 453 02-S	190°F Thermostat	LV625-680, LH640-775
66 453 03-S	205°F Thermostat	LV625-680, LH640-775



CAUTION (ALL WARNING DEVICES ON THIS PAGE):

1. If overheating occurs, remove load, run engine at high speed to create air flow for cooling engine.
2. If low oil level/pressure occurs, stop engine immediately.

Controls

TAMPER-RESISTANT CONTROL KITS

Prevents tampering with high-speed adjustment (as proposed by European regulations).

Kit No.	For Models	When Models Are Equipped With	Note
24 755 97-S	CV18-26/730-745	Top Controls	A

A — Includes cover and (2) TORX screws for attachment to control bracket. Instructions are included to add holes to the bracket if there are none.

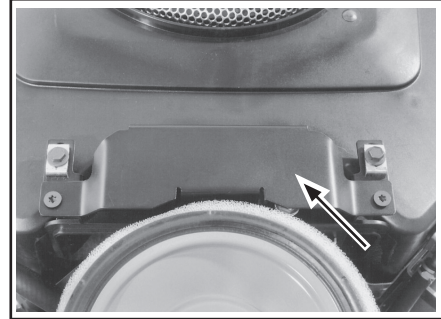

KEY SWITCH AND KEYS

Part No.	Description Models	Item
25 099 37-S	Switch (5 pin) & Key Magneto EFI, ECH-ECV (Delphi)	1
25 099 29-S	Switch (5 pin) & Key CH940-1000	1
52 099 02-S	Switch (3 pin) & Key EFI (Bosch)	1
25 099 30-S	Switch (5 pin) & Key (Plastic) CH640-750, CV17-26, CV624-750	2
17 340 11-S*	CH270-440 Keys	4
18 340 02-S	WH208 Key	5
48 340 01-S	Keys (fits items 1 and 2)	3
24 340 03-S	Keys, bell shape (fits items 1 and 2)	6

*Fits switch used in elongated keybox.

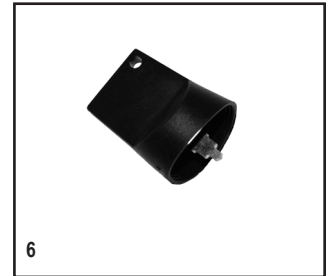
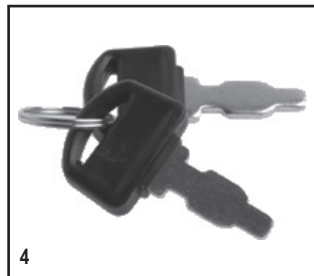
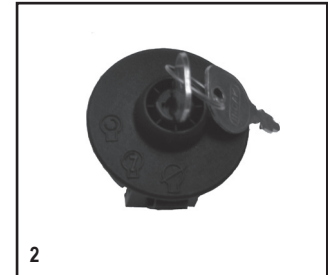
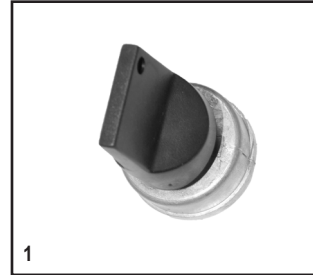

KEY SWITCH PLUGS

Part No.	Description	Item
25 139 16-S	Round plastic plug (fits into metal key switch hole)	1
25 139 17-S	Round plastic plug (fits plastic key switch plug) 25 139 76-S)	2
25 139 76-S	Plastic key switch plug	3



IDLE DOWN SOLENOID KITS

Part No.	Description
17 755 29-S	CH270 Idle down solenoid (w/o key box)
17 755 30-S	CH270 Idle down solenoid (w/key box)
17 755 31-S	CH395 Idle down solenoid (w/o key box)
17 755 32-S	CH395 Idle down solenoid (w/key box)
17 755 35-S*	Required to provide packaged component for the servicing of CH440 engines with fixed speed and without a Kohler-supplied fuel tank.

*If engine is equipped with a variable speed control, also order Fixed Speed Lever 17 090 47-S.

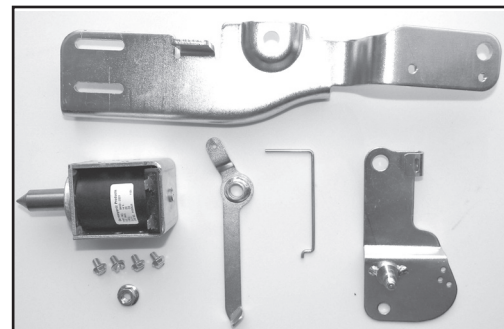

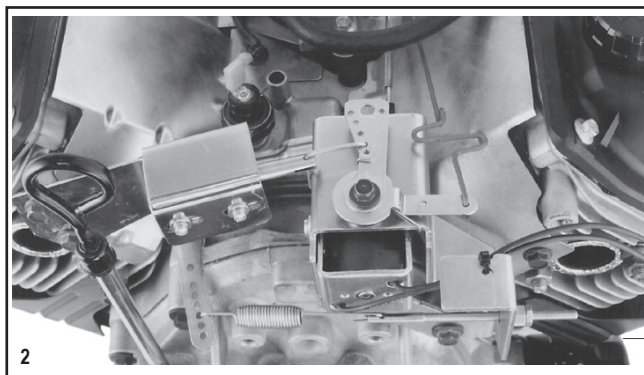
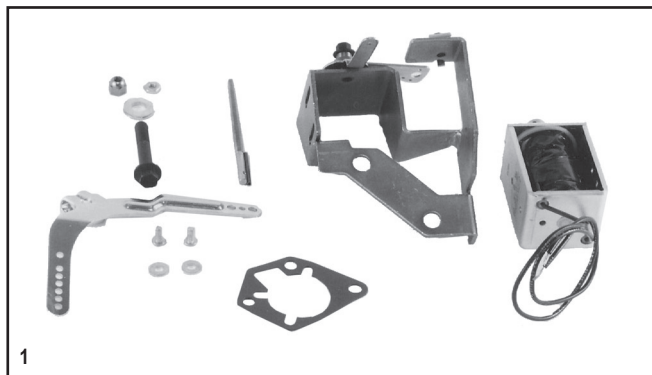

SOLENOID-OPERATED CONTROLS (12 DC VOLTS)

Kit No.	Description	For Engines With	Models	Item
24 755 100-S	Idle Kit*	Constant Speed	CH18-25/730-740, LH640-755***	1
24 755 101-S	Throttle/Choke Kit**	Constant Speed	CH18-25/730-740, LH640-755***	2

* When voltage is applied to solenoid, engine speed is "low idle." When voltage is removed, engine speed is "high idle."
 ** Allows start-up to constant high speed from remote equipment (lift platform, etc.). Not compatible with side-mount muffler.
 *** Mounting bracket will interfere with manifolds on CH18-25/730-740 side mufflers. Also 24 164 04-S Crossover Manifold.

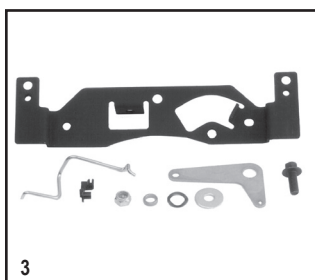
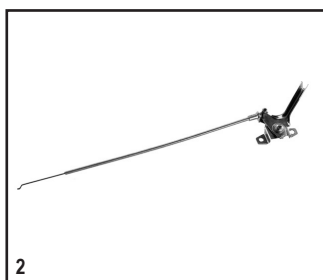

THROTTLE CONTROL

Part No.	Description/Mount Type	Cable Length	Models	Item
63 089 23-S	Throttle Return Spring*	—	CS4-12	1
225011-2-S	Remote	41-51"	All	2
225011-6-S	Remote	60-72"	All	2
225011-7-S	Remote	12-40"	All	2

*For recreational vehicle applications. Returns engine speed to idle when foot pedal is released.

CHOKE CONTROL

Part No.	Description/Mount Type	Models	Item
24 755 95-S	Choke Control Kit (Adds choke control lever to top controls).	CV17-25/730-740 Commercial Mowers	3

REMOTE THROTTLE KITS

Part No.	Description	Model	Item
17 755 04-S	Remote Throttle Kit	CH270	1
17 755 05-S	Remote Throttle Kit	CH395/440	2

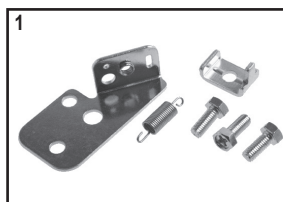

CABLE CLAMP

Part No.	Description	Models	Item
17 237 13-S	Cable Clamp (Clamps braided throttle cable)	CH270-440	3
18 755 04-S	Barrel/Bowden Clamp	SH265	—



REMOTE CHOKE KITS

Part No.	Description/Mount Type	Models	Item
17 755 16-S	Remote Choke Kit (Fits Quad-Clean models)	CH395/440	—
17 755 17-S	Remote Choke Kit (Fits Low-Profile air cleaner models)	CH395/440	4
17 755 47-S	Remote Choke Kit	CH270	—

Electrical Accessories

HIGH TEMPERATURE CUTOUT SWITCH

Kit No.	Cutout Range	Reset	Models
24 703 01-S	440-490°F	415°F	CH/CV17-26/ 730-745 SV710-740

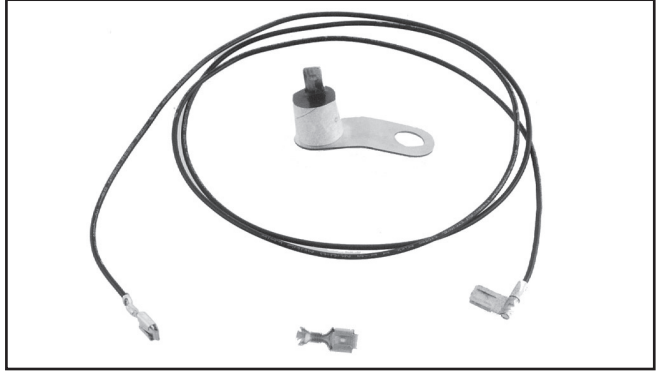

MALFUNCTION INDICATOR LAMP (MIL)

Part No.	Models With
25 352 19-S	Electronic Fuel Injection (EFI)
25 352 25-S	LED EFI



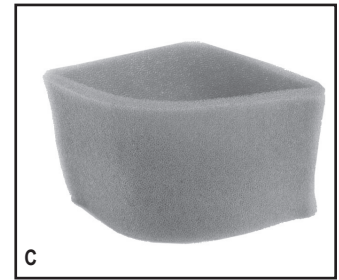
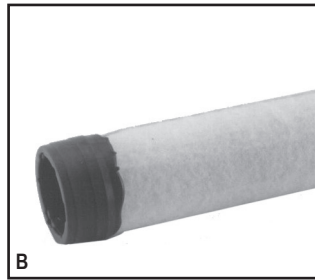
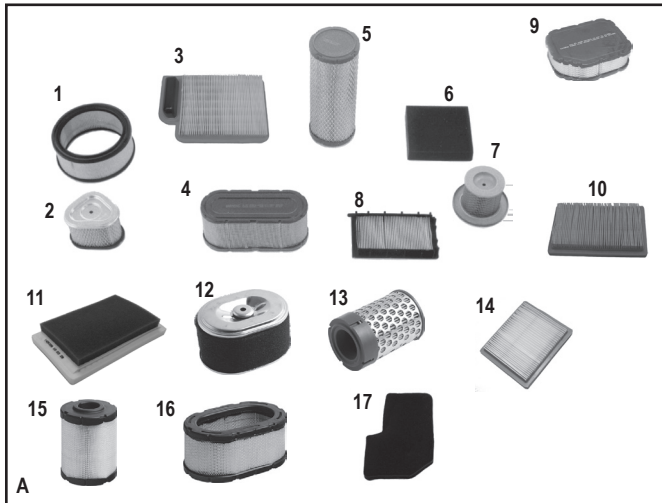

ELEMENTS AND PRECLEANERS

Note: Elements and precleaners may appear differently for various models.

Style	Element (Photo A)	U.L. Element Equivalent	Inner Element (Photo B)	Precleaner (Photo C)	Models
1	45 083 02-S	52 083 04-S	—	45 083 01-S	CV17-26/730-745 (Commercial mowing)
1	47 083 01-S	47 083 04-S	—	52 083 01-S	CH11-15
4	63 083 03-S	—	—	63 083 04-S	CS4-6 (Standard, dual element)
4	63 083 11-S	—	—	63 083 12-S	CS8.5/250cc (Standard, dual element)
4	63 083 01-S	—	—	63 083 02-S	CS8.5/300cc, 10-12 (Standard, dual element)
6	63 083 06-S	—	—	—	CS4-6 (Foam, single element)
6	63 083 05-S	—	—	—	CS8.5/300cc, 10-12 (Foam, single element)
7	63 083 07-S	—	—	63 083 08-S	CS4-6 (Heavy-duty cyclonic)
7	63 083 10-S	—	—	63 083 09-S	CS8.5/250-300cc, 10-12 (Heavy-duty cyclonic)
8	63 083 13-S	—	—	63 083 14-S	CS8.5/250cc (Low profile, dual element)
4	63 083 15-S	—	—	63 083 16-S	CS10(931600), CS12 (941600)
3	20 083 06-S	20 083 07-S	—	20 083 04-S	SV470-620
2	12 083 05-S*	12 083 09-S*	—	12 083 08-S	CV11-16/460-493 (Standard, 2.8" High)
2	12 083 10-S*	12 083 13-S*	—	12 083 12-S	CV11-16/460-493 (Tall, 3.4" High)
1	47 083 03-S	24 083 08-S	—	24 083 02-S	CH/CV17-23 (Flat)
1	24 083 03-S	24 083 09-S	—	24 083 05-S	CH/CV25-26/730-745, ECH/ECV630-749 (Flat)
5	24 083 07-S	—	—	—	CH/CV17-22 Metal H.D. A/C
5	25 083 01-S	—	25 083 04-S	—	CH/CV17-26/620-1000/LH640-775 Plastic H.D. A/C
5	25 083 02-S	—	25 083 03-S	—	ECH/ECV630-980
9	32 083 03-S	—	—	—	CV493
9	32 083 06-S	—	—	32 083 05-S	SV710-740 (Standard, 1.73" High)
4	66 083 01-S	—	—	32 083 08-S	SV810-840 (Large, 3" High)
10	14 083 01-S	—	—	66 083 03-S	LV625-680
11	14 083 09-S	—	—	14 083 02-S	XT-7 (Paper)
13	17 083 23-S	—	—	—	XT-7 (Foam)
13	17 083 21-S	—	—	17 083 12-S	CH270
12	18 083 04-S	—	—	17 083 15-S	CH395/440
9	62 083 04-S	—	—	18 083 05-S	SH265
14	14 083 15-S	—	—	62 083 03-S	CH940-1000 (with Low-Profile air cleaner)
15	16 083 01-S	—	—	—	XT650, XT675 (Paper)
15	32 083 13-S	—	—	16 083 02-S	ZT710-ZT740, EZT740-EZT750
16	16 083 04-S	—	—	32 083 14-S	KT735-745 PRO, EKT740-EKT750
—	18 083 13-S	—	—	16 083 05-S	ZT710-ZT740, KT715-KT745
17	18 083 14-S	—	—	—	RH255, RH265 (Paper)
16	32 083 09-S	32 083 12-S	—	—	RH255, RH265 (Foam)
				32 083 10-S	KT715-KT745

Notes: *Includes element and rubber seal.

ALSO SEE PAGE 17 FOR RECOIL STARTER FILTERS.

Air Intake

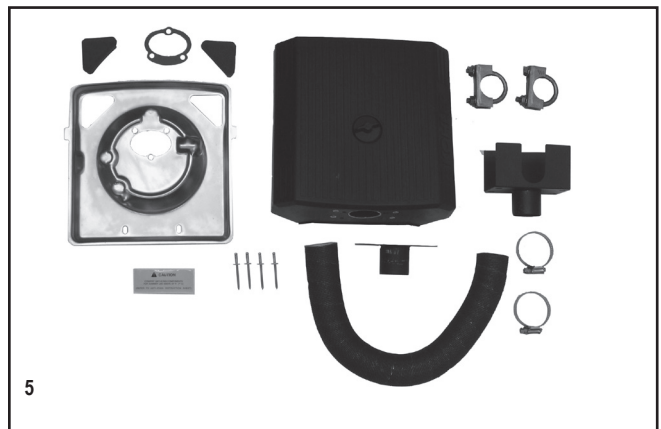
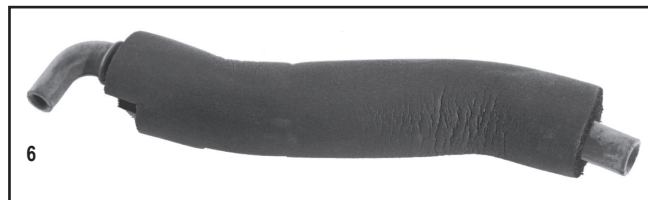
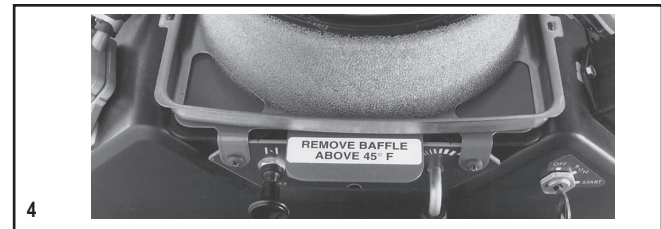
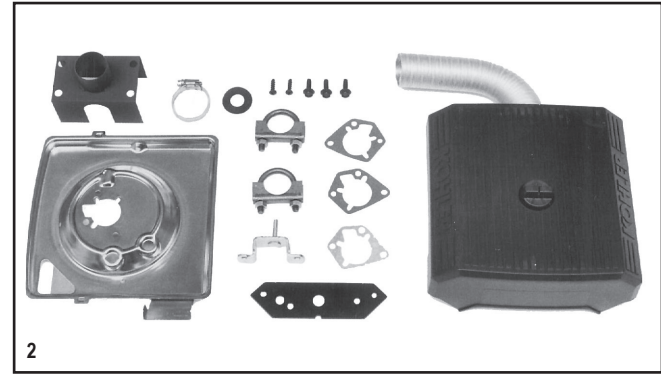
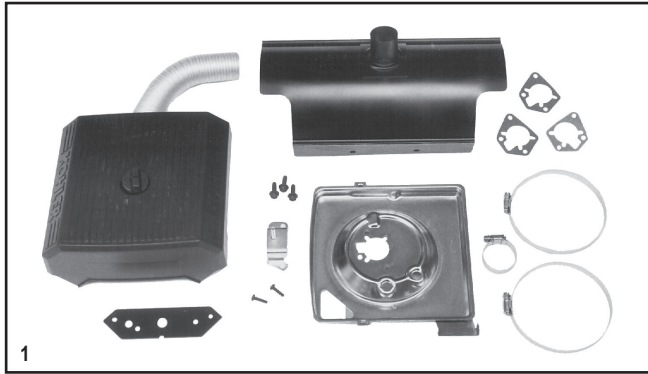

ANTI-ICING COMPONENTS

If the included instructions are followed, these kits/parts may be used without jeopardizing CARB/EPA certification on the engine.

Kit No.	Models	As Low As	Notes	Heat From	Item
24 755 64-S	CH18-22	20°F	For PTO mufflers	Muffler	1 (shown)
24 755 65-S	CH25-26/730-745	20°F	For PTO mufflers	Muffler	1
24 755 68-S*	CH18-22	20°F	For side mufflers	Manifold	2 (shown)
24 755 69-S*	CH25-26/730-745	20°F	For side mufflers	Manifold	2
24 755 82-S	CH18-26/730-745	-20°F	Includes starter side muffler***	Muffler	3
24 755 83-S*	CH18-22	-20°F	Includes filter side muffler***	Muffler	3 (shown)
54 755 06-S**	CH/CV17-26/730-745, ECH630-749	—	Not for commercial mowers	—	4
12 168 02-S	CH18-26/730-745	—	Foam insulation only	—	—
24 168 01-S	LH640-775	—	Breather hose insulation	—	—
24 755 165-S	CH750 w/Flat Air Cleaners	—	For side mufflers	Manifold	5
12 326 28-S****	CH11-15	—	Insulated breather hose	—	6
24 755 238-S	ECH630-749	—	Includes starter side muffler	Muffler	—

* Not for use on filter side of engine if equipped with oil cooler.

** Increases carburetor temperature approximately 13°F. Covers triangular holes (2) in blower housing. Remove above 45°F.

*** Tubes travel through mufflers to bring warm air to air cleaner.

**** Replaces existing breather hose to prevent icing, or order insulation only and install over existing hose.

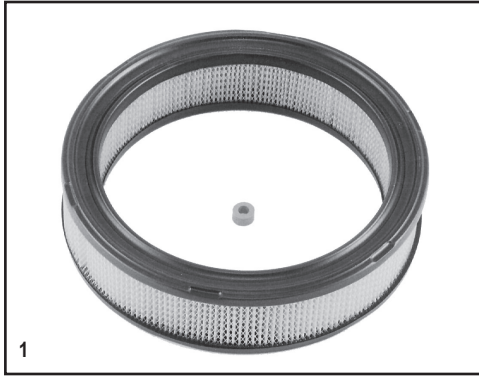

SEAL RETROFIT KIT

Kit No.	Description	Models	Item
12 743 09-S	Seal Retrofit Kit	CH11-15	1

For engines before Serial No. 2519500004. Seal replaces loose washer and grommet in cover plate. Kit includes seal and element.

AIR CLEANER COVER

Part No.	Description	Models	Item
12 096 41-S	Air Cleaner Cover (w/multilingual maintenance instructions)	CH11-15	2

Standard air cleaner cover, including multilingual maintenance instructions embossed underneath. Now available individually for engines built earlier.

AIR CLEANER COVER

Part No.	Description	Models
14 096 90-S	Air Cleaner Cover Kit (Snorkel)	XT-6, XT-7, XT8

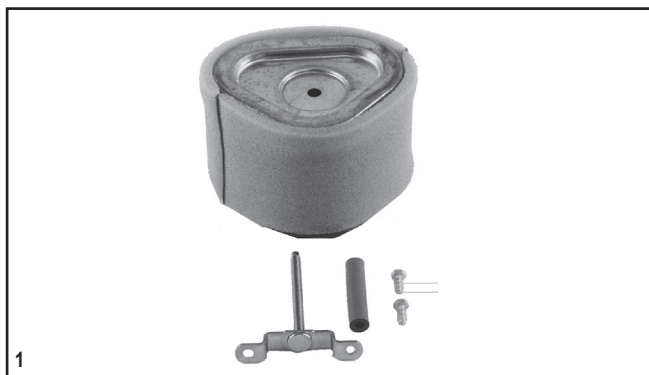

AIR CLEANER RETROFIT KITS

Kit No.	Description	Includes Filter	For Specification	Item
12 743 03-S	Converts standard filter to a larger filter	Large*	A	1
12 743 04-S	Cover has opening to line up with opening in blower housing	Large*	B	2

A — Pro Series "T/ST" after Serial No. 2404917244, Pro Series "S" after Serial No. 2424505854.
 B — Basic "S", lawn tractors.
 *Large capacity filter is 20% greater than standard filter.

Air Intake

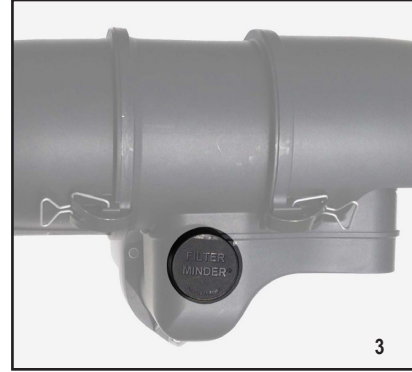
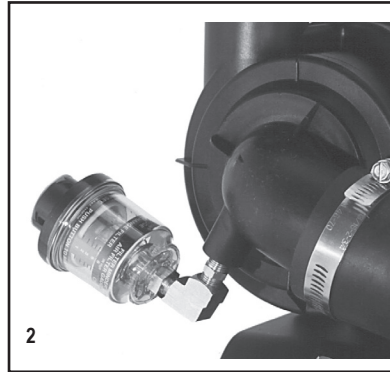
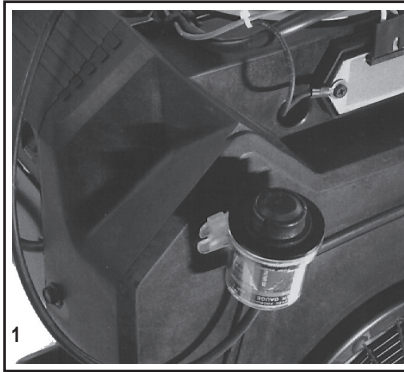

FILTER MINDER

Vacuum-type gauge detects air inlet restrictions, signaling when to service air filter (when yellow indicator reaches red line).

Kit No.	Mounting	Air Drawn From	Models	Item
25 755 18-S	Remote	Air cleaner base plate or heavy-duty air cleaner elbow	CH/CV11-16/460-493, CH/CV17-26/730-745	1
25 755 24-S	Direct*	Heavy-duty air cleaner elbow	CH18-26/730-750, CV493	2
62 330 02-S	Direct	Fits Kohler-style heavy-duty air cleaners	CH/CV940-1000	3
16 755 04-S	—	—	ZT710-ZT740	—

* Includes brass fittings, instructions.

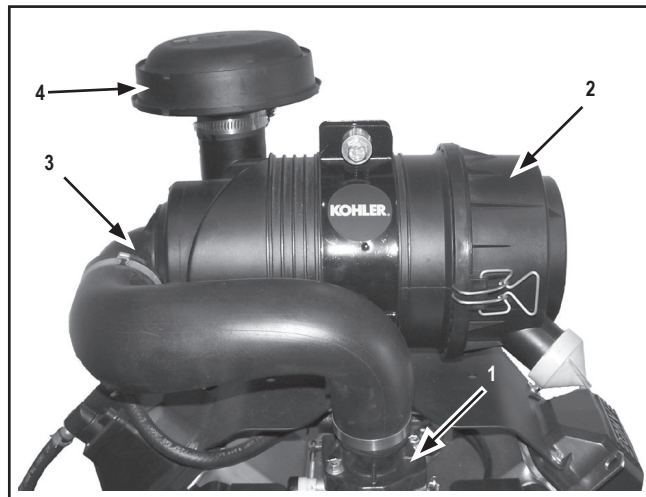

HEAVY-DUTY AIR CLEANER KITS (Convert from Flat Air Cleaner)

Complete, engine-mounted system (items 1 and 2 used together) is CARB/EPA certified. Any remote-mounting configuration (item 1 plus remote-mounted air cleaner), must be Kohler approved for CARB/EPA. Filtering area is 1,398 sq. in. **Not usable on engines with plastic intake manifold.**

Kit No.	Description	Includes	Use With	Models	Item
24 743 20-S	Elbow/Adapter Kit*	A	AA	CH18-22 (624cc)/620/640/730-740	1
24 743 25-S	Elbow/Adapter Kit	A	AA	CH22/23 (674cc)/680	1
24 743 21-S	Elbow/Adapter Kit	A	AA	CH25	1
24 743 34-S	Elbow/Adapter Kit	A	AA CH26/745	EFI	1
24 743 22-S	Air Cleaner Kit (90° canister elbow)**	B	BB	All	2
24 743 23-S	Air Cleaner Kit (Straight canister elbow)***	C	BB	All	2
25 755 24-S	Filter Minder Kit (Elbow mounted)****	D	AA	All	3
25 755 18-S	Filter Minder Kit (Remote mounted)*****	E	AA	All	—
25 324 04-S	Inlet Hood Cap (includes clamp)	—	—	—	4

* For CH730/740, carburetor replacement is necessary. Order assembly 24 853 93-S.

** Typically used for engine-mounted configuration (as shown). If remote-mounted, customer supplies hose (must be Kohler approved for CARB/EPA).

*** Used with customer-supplied hose for remote-mount location. (Must be Kohler approved for CARB/EPA).

**** Attaches to air canister elbow (per item 3). (See earlier page for description.)

***** Attaches to any remote location (front of engine, application, etc.). (See earlier page for description).

Kits include instructions plus:

A - Elbow/adaptor, mounting bracket, 2" I.D. hose, hardware, debris shields for either knob-type or lever-type controls (see below).

B - Air Cleaner Canister, Rain Hood (25 324 04-S), Main and Inner Filters, Plug (25 139 20-S) to close Filter Minder opening if not used.

C - Air Cleaner Canister, Rain Hood (25 324 04-S), Main and Inner Filters, Cap (25 173 19-S) to close Filter Minder opening if not used.

D - Filter Minder, brass fittings.

E - Filter Minder, brass fittings, 10' hose, mounting bracket.

Use with:

AA - Air Cleaner Kit 24 743 22-S or customer-supplied air cleaner, which must be Kohler approved for CARB/EPA.

BB - Elbow/Adapter Kit 24 743 20-S, 25-S, 21-S or 34-S.

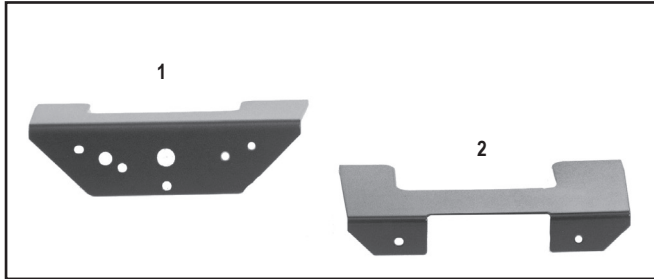

DEBRIS SHIELDS

Both shields are included in Heavy-Duty Air Cleaner Kits (carburetor/elbow) to prevent debris from interfering with throttle/choke controls. (Only one shield needed depending upon engine specification).

Part No.	Used With	Models	Item
24 314 25-S	Knob-type controls, no controls, remote air cleaner	CH18-26/730-745	1
24 314 29-S	Lever-type controls*	CH18-26/730-745	2

*Lever-type controls have been standard on CH18-25 panel specifications since Serial No. 3009400011.

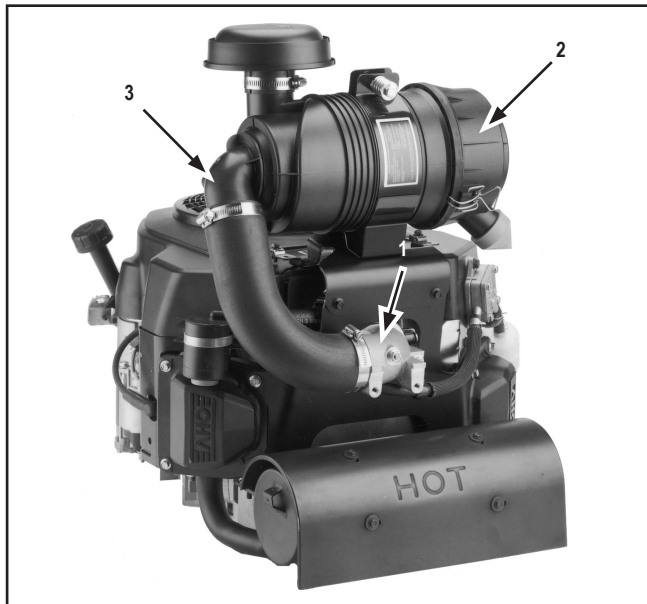

HEAVY-DUTY AIR CLEANER KITS

(Convert from Flat or Commercial Mower Air Cleaner)

Complete, engine-mounted systems are CARB/EPA certified. Remote systems using either KOHLER® or customer-supplied air cleaner and hose, must be Kohler approved for CARB/EPA. Filtering area is 1,398 sq. in. **Not usable on Command engines with plastic intake manifold.**

Kit No.	Description	Includes	Use With	Models	Item
24 743 40-S	Elbow/Adapter Kit	A	AA	Command CV18-22 (624cc)/620-640	1
24 743 41-S	Elbow/Adapter Kit	A	AA	Command CV22/23 (674cc)/680	1
24 743 42-S	Elbow/Adapter Kit	A	AA	Command CV25/730-740	1
24 743 22-S	Air Cleaner Kit (90° canister elbow)*	B	BB	Command or Aegis*****	2
24 743 23-S	Air Cleaner Kit (straight canister elbow)**	C	BB	Command or Aegis*****	2
25 755 24-S	Filter Minder Kit (Elbow-mounted****)	E	AA	All	3
25 755 18-S	Filter Minder Kit (Remote-mounted****)	F	AA	All	-

* Typically used for engine-mounted configuration (as shown). Not compatible with vertical positioned mufflers as shown in EXHAUST section.

** Used with customer-supplied hose for remote-mount location. (Must be Kohler-approved for CARB/EPA).

*** Attaches to outlet in canister. (See appearance and description of Filter Minder on earlier page).

**** Attaches to any remote location. (See appearance and description of Filter Minder on earlier page).

***** Usable on Aegis but **only** in remote-mount configuration, not engine-mounted.

Kits include instructions plus:

A - Carburetor, elbow/adapter, mounting brackets, 2" I.D. hose, hardware.

B - Air Cleaner Canister(†), Rain Hood (25 324 04-S), Main and Inner Filters, Plug (25 139 20-S) to close Filter Minder opening if not used.

C - Air Cleaner Canister(‡), Rain Hood (25 324 04-S), Main and Inner Filters, Cap (25 173 19-S) to close Filter Minder opening if not used.

D - Elbow/adapter, air cleaner gaskets, miscellaneous hardware. Customer supplies 2" I.D. remote hose to air cleaner. (Must be Kohler-approved for CARB/EPA).

E - Filter Minder, brass fittings.

F - Filter Minder, brass fittings, 10' hose, mounting bracket.

(†) 90° Air Cleaner Canister is comprised of: 25 081 01-S Main Body, 25 096 06-S End Cap w/Ejector Valve and Clips.

(‡) Straight Air Cleaner Canister is comprised of: no - S part number for Main Body, 25 096 06-S End Cap w/Ejector Valve and Clips.

Use with:

AA - Air Cleaner Kit 24 743 22-S . . . or customer-supplied air cleaner and hose, which must be Kohler-approved for CARB/EPA.

BB - Elbow/Adapter Kit 24 743 36-S, 37-S and 38-S; or 66 743 01-S (remote-mount only).

CC - Air Cleaner Kit 24 743 22-S or 23-S may **only** be used in remote-mounted configuration, not engine-mounted. Customer supplies 2" I.D. hose. (Must be Kohler-approved for CARB/EPA).

Air Intake

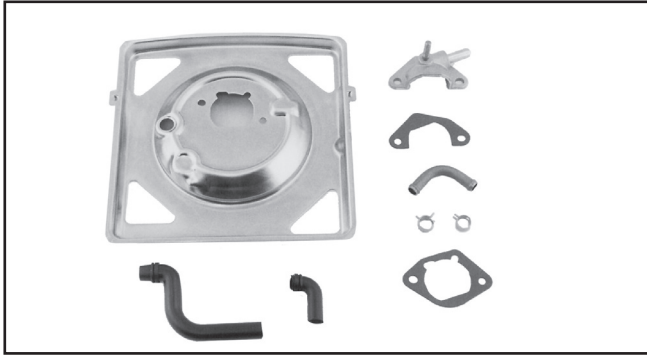

AIR CLEANER BASE/BREATHER KIT

Kit No.	Description	Models
24 755 86-S	Base/breather kit	CV17-25/730-740

Note: Breather system for models with accelerator pump carburetor.

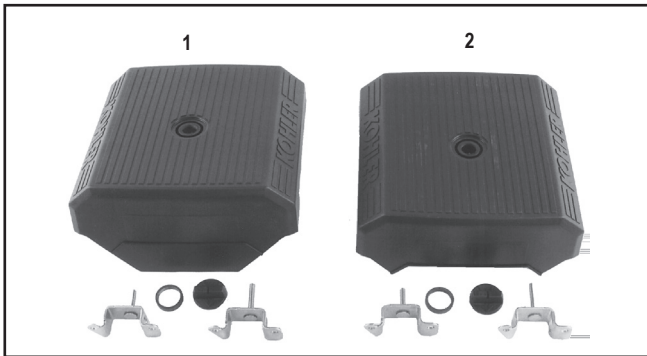

AIR CLEANER COVER KITS STANDARD

Kit No.	For Engine With	Models	Item
24 743 05-S	No control panel	CH/CV17-25/730-740*	1
24 743 06-S	Control panel	CH18-26/730-740	2

Note: Covers include embossed KOHLER® name on outside, maintenance instructions on inside (English, Spanish, German, French).
 *CV17-25/730-740 with standard air cleaner also requires 24 755 86-S Kit.

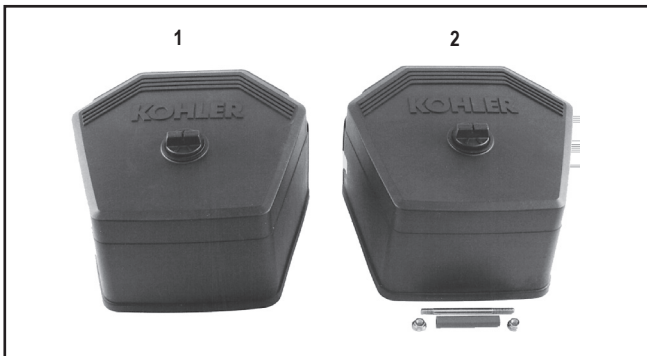

AIR CLEANER COVER KITS COMMERCIAL MOWER

Kit No.	Models	Item
24 743 11-S*	CV17-25/730-740	1
24 743 17-S**	CV17-25/730-740	2
24 743 32-S**	CV26/745	2

Note: Covers include embossed KOHLER® name on outside, maintenance instructions on inside (English, Spanish, German, French).

* Cover is made of high-temperature material for extreme conditions.

** Same as -11-S kit, but includes stud, seal and nuts for high-moisture conditions preventing water seepage under cover.

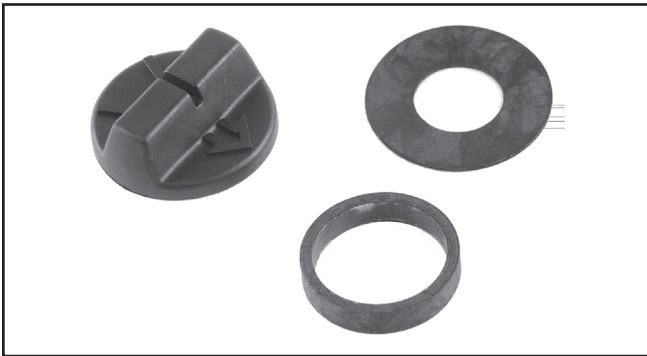

KNOB REPLACEMENT KIT

Kit No.	Description	Models
54 755 01-S	Knob Kit	CH/CV17-26/730-750



CS4-6 MUFFLER

Kit includes muffler and gasket. Use hardware from existing muffler.

Kit No.	Outlet Location	Outlet O.D.	Muffler Length	Outlet Tube Length	Models	Item
63 786 01-S	Throttle Side*	1.0"	9.46"	1.0"	CS4-6	1

*Outlet is on opposite side of standard muffler location. Also allows for unobstructed PTO face.

COURAGE SINGLE (SV470-620) MUFFLER KIT

Kit includes muffler, gasket, support bracket, hardware and instructions.

Kit No.	Description	Engine Side	Outlet D.B.C.	Item
20 786 02-S***	Muffler Kit	Starter	2.047	2
20 755 10-S	Guard Kit*			2
12 755 107-S	Guard Kit**			2

*Cage open at bottom to avoid interference with deck.

**Cage closed at bottom.

***Not compliant for California.

EXHAUST FLANGE

For adapting manifold length to customer-supplied exhaust.

Part No.	Description	Models	Item
20 295 01-S	Steel, 0.188 thick	SV470-620	3
17 295 03-S	Steel, 0.25 thick	CH395	3

COURAGE TWIN (SV710-840) AND 7000 SERIES (KT715-745) MUFFLER KIT

Kit includes muffler, gasket, slip-fit manifolds, and screws. Customer supplies mounting bracket to frame.

Kit No.	Muffler Only	Outlet Location/Direction	Item
32 786 01-S	32 068 01-S	Bottom/Toward Oil Filter	4

COURAGE TWIN AND 7000 SERIES (KT715-745) EXTENDED MANIFOLDS

Part No.	Item
32 164 06-S	9
32 164 07-S	10

XT MUFFLER KIT

Kit includes muffler and heat deflector.

Kit No.	Choke Type	Outlet Location/Direction	Item
14 068 15-S	Manual/Primer	Front Discharge	5
14 068 08-S	Manual/Primer	Side Discharge	6
14 068 05-S	Auto	Front Discharge	-
14 068 07-S	Auto	Side Discharge	-

XT MUFFLER GUARD

Part No.	Description	Item
14 314 04-S	For front discharge mufflers	7
14 314 09-S	For side discharge mufflers	8

Exhaust

COMMAND PRO HORIZONTAL MUFFLERS

Part No.	Description	Models	Item
17 068 31-S*	Low profile	CH270	-
17 068 38-S	Low profile	CH395	-
17 068 40-S	Low profile	CH440	1

*Outer shield requires OEM supplied bracket.



GUARD KIT (EU REQUIREMENTS)

Part No.	For Muffler	Model
17 314 122-S	17 068 55	CH270
17 314 123-S	17 068 76	CH395
17 314 124-S	17 068 87	CH440

3000 SERIES MUFFLERS

Part No.	Description	Item
18 068 08-S	Low profile muffler	1
18 068 14-S	Muffler and deflector	-



CONFIDANT AND 7000 SERIES MUFFLERS

Kit No.	Muffler Only	Description	Item
32 786 03-S	16 068 02-S	Oil Filter Side	1
32 786 05-S	16 068 01-S	Starter Side	2
32 786 04-S	—	Horizontal Canister	3
32 786 06-S	—	Horizontal Canister*	4

* For Wright Mowers

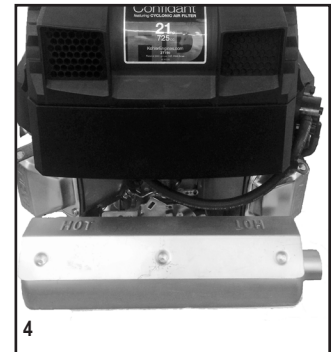
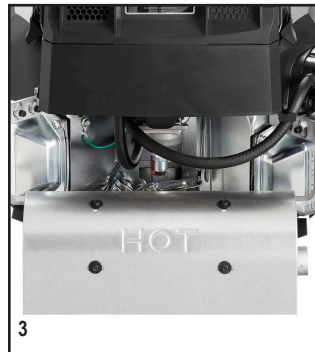
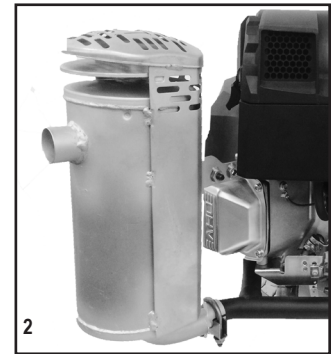

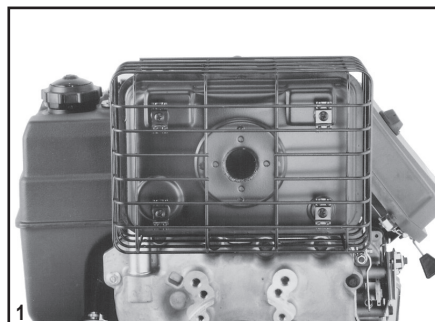

1 Includes Exhaust Deflector (not shown).

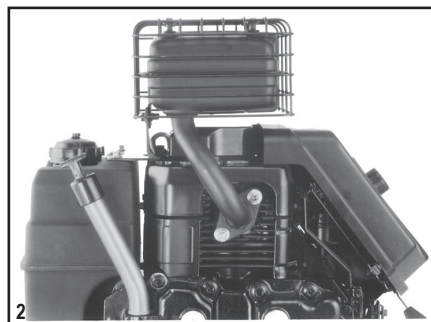

2 Includes Exhaust Deflector (not shown).

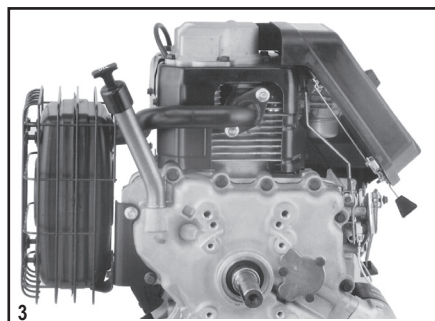

3 Vertical Orientation

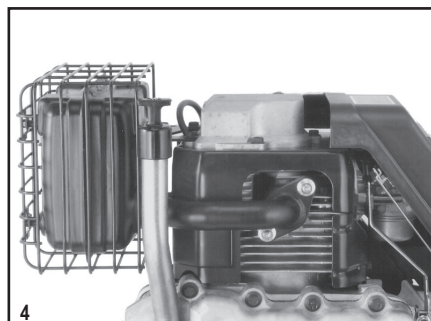

4 Horizontal Orientation

PILLOW MUFFLERS AND GUARDS (CH11-15)

Muffler kits include oil fill tube/dipstick as pictured . . . to avoid interference with muffler or guard . . . including sealant and a driver to aid in installation. Mufflers have stand offs for attaching optional wire guard. Guard kits do not include muffler.

Part No.	Muffler Only	Description	Engine Side	Outlet D.B.C.	A	B	C	D	E	F	G	H	Item
12 786 09-S*	12 068 26-S	Muffler Kit	PTO	2.047"	13.0"	—	7.0"	—	5.0"	—	4.25"	—	1
12 786 13-S**	12 068 38-S	Muffler Kit	PTO	2.047"	13.0"	—	7.0"	—	5.0"	—	4.25"	—	1
12 755 107-S	—	Guard Kit	PTO	—	—	13.5"	—	6.25"	—	5.5"	—	5.0"	1
12 786 08-S*	12 068 25-S	Muffler Kit	Top	2.047"	17.0"	—	13.25"	—	4.5"	—	—	—	2
12 786 12-S**	12 068 39-S	Muffler Kit	Top	2.047"	17.0"	—	13.25"	—	4.5"	—	—	—	2
12 755 107-S	—	Guard Kit	Top	—	—	17.75"	—	13.125"	—	5.0"	—	—	2
12 786 10-S*	12 068 27-S	Muffler Kit***	Starter, No Tank	2.047"	8.0"	—	1.0"	—	11.0"	—	—	—	3
12 786 14-S**	—	Muffler Kit***	Starter, No Tank	2.047"	8.0"	—	1.0"	—	11.0"	—	—	—	3
12 786 11-S*	12 068 23-S	Muffler Kit	Starter, No Tank	2.047"	13.0"	—	7.0"	—	10.0"	—	—	—	4
12 786 15-S**	12 068 40-S	Muffler Kit	Starter, No Tank	2.047"	13.0"	—	7.0"	—	10.0"	—	—	—	4
12 755 107-S	—	Guard Kit	Starter, No Tank	—	—	13.75"	—	6.25"	—	10.5"	—	—	4

* Muffler has no integral port liner. It is usable only on CH11-14 models below Serial No. 2628900001.

** Muffler has integral port liner extending from mounting flange, to interface with cored-out cylinder head. Only for models with Serial No. 2628900001 or higher, which include cored-out cylinder head.

*** Muffler kit not usable on specifications with fuel pump.

**** For CH14 LP engines only; includes oxygen sensor port in manifold-to-muffler pipe.

A — Centerline of crank to top of muffler.

E — Centerline of crank to left edge of muffler.

B — Centerline of crank to top of guard.

F — Centerline of crank to left edge of guard.

C — Centerline of crank to bottom of muffler.

G — From PTO face to farthest edge of muffler.

D — Centerline of crank to bottom of guard.

H — From PTO face to farthest edge of guard.

Exhaust

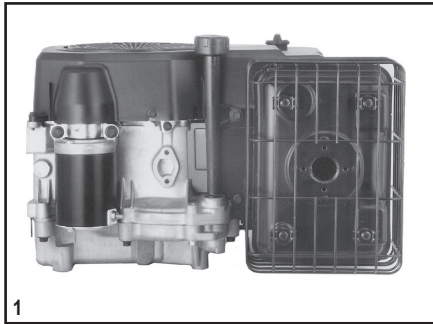

1 Vertical Orientation (Standard)

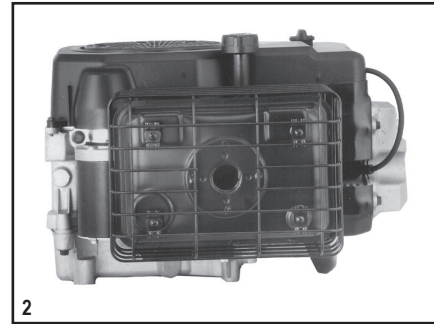

2 Horizontal Orientation

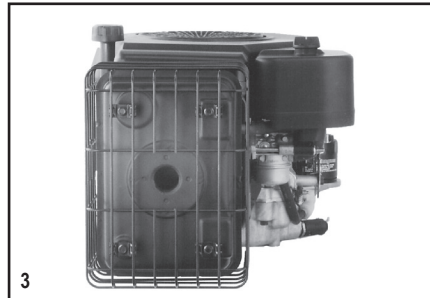

3 Valve Cover Orientation

PILLOW MUFFLERS AND GUARDS (CV11-16/460-493)

Guard kits do not include muffler. **Note:** Mufflers 12 068 54-S and 55-S are exclusive to CV460-493, 12 068 39-S is also useable. No other mufflers are usable on these Models.

Part No.	Description	Engine Side	Stand Offs For Guard	Hardware (See note)	Outlet D.B.C.	A	B	C	D	E	F	Item
12 068 21-S*	Muffler (Standard)	Starter	No	1	2.047"	12.0"	—	0.75"	—	4.5"	—	1
12 068 44-S**	Muffler (Standard)	Starter	No	1	2.047"	12.0"	—	10.75"	—	4.5"	—	1
12 068 54-S**	Muffler	Starter	No	1	2.047"	12.47"	—	10.75"	—	4.5"	—	1
12 068 23-S*	Muffler	Starter	Yes	1	2.047"	12.0"	—	10.75"	—	4.5"	—	1
12 068 40-S**	Muffler	Starter	Yes	1	2.047"	12.0"	—	10.75"	—	4.5"	—	1
12 068 55-S**	Muffler	Starter	Yes	1	2.047"	12.47"	—	10.75"	—	4.5"	—	1
12 755 107-S	Guard Kit	Starter	—	—	—	—	12.5"	—	11.25"	—	5.25"	1
						(12.97"/460-493)						
12 068 20-S*	Muffler***	Starter	No	2	2.047"	8.0"	—	9.25"	—	3.75"	—	2
12 068 42-S**	Muffler***	Starter	No	2	2.047"	8.0"	—	9.25"	—	3.75"	—	2
12 068 25-S*	Muffler	Valve	Yes	3	2.047"	2.5"	—	10.5"	—	—	—	3
12 068 39-S**	Muffler	Valve	Yes	3	2.047"	2.5"	—	10.5"	—	—	—	3

* Muffler has no integral port liner. It is usable only on CV11-14 models below Serial No. 2628900001.

** Muffler has integral port liner extending from mounting flange, to interface with cored-out cylinder head. Only for models with Serial No. 2628900001 or higher, which include cored-out cylinder head.

*** Muffler not usable on specifications with fuel pump.

**** For CV14 LP engines only; includes oxygen sensor port in manifold-to-muffler pipe.

Note: For Mufflers 12 068 25-S and 12 068 39-S, only Guard 12 755 107-S is necessary for EEC. Mufflers 12 068 20-S, 12 068 21-S, 12 068 42-S and 12 068 44-S do not have weld nuts for guard attachment, so they cannot be made EEC-compliant.

A — Centerline of crank to right edge of muffler.

B — Centerline of crank to right edge of guard.

C — Mounting surface to top of muffler.

D — Mounting surface to top of guard.

E — Centerline of oil fill cap to outer edge of muffler.

F — Centerline of oil fill cap to outer edge of guard.

Mounting Hardware (if not presently on engine)

1 - Order (1) 12 126 71-S Bracket, (2) 25 086 395-S Screw, (1) 25 086 398-S Screw, (2) M-841080 Nut, (1) X-25-78-S Washer. (2) 12 112 20-S Spacer (sheet metal valve cover only).

2 - Order 12 755 30-S Mounting Kit.

3 - Order (1) 12 126 56-S Bracket, (2) 25 085 395-S Screw, (2) 25 086 397-S Screw, (1) 12 041 03-S Gasket, (2) M-841060-S Nut, (2) 12 112 20-S Spacer (sheet metal valve cover only).

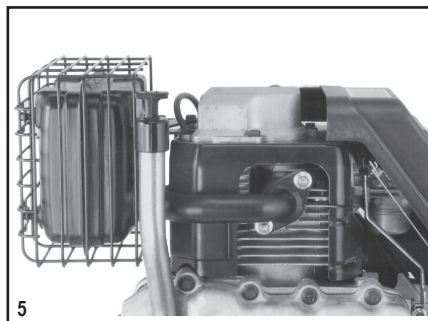
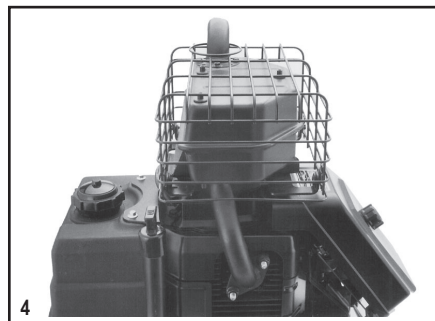
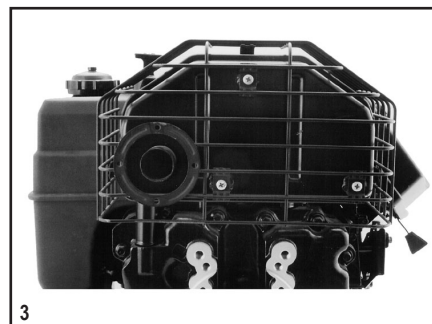
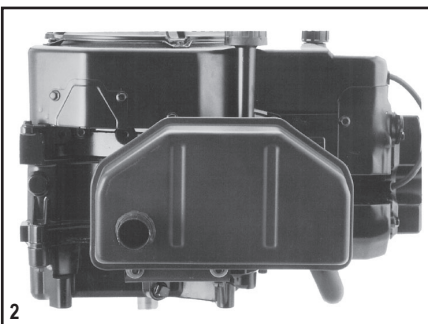
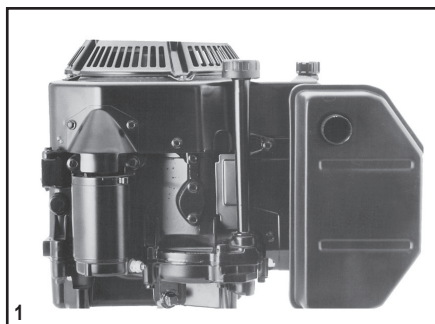

HAM CAN MUFFLERS (CH/CV11-15)

CV Models

CH Models

Part No.	Description	Outlet O.D.	A	Side	Item
12 068 01-S	Muffler	1.25"	4.94"	Starter	1
12 786 18-S	Mounting Kit*	—	—	Starter	1
12 068 03-S	Muffler	1.25"	6.5"	Starter	2
12 068 35-S	Muffler**	1.25"	6.5"	Starter	2
12 755 30-S	Mounting Kit*	—	—	Starter	2

A — Extends away from blower housing.

*Includes brackets, gasket, hardware.

**Identical to the -03 muffler, but includes integral port liner extending from the mounting flange. Only ham can muffler usable on CV11-15 models with cored-out cylinder head, Serial No. 2628900001 and higher.

Part No.	Description	Outlet D.B.C.	Space	Side	Item
12 068 11-S	Muffler only**	2.047"	B	PTO	3
12 786 04-S	Mounting Kit ***	—	—	PTO	3
12 755 26-S	Guard Kit	—	B	PTO	3
12 068 11-S	Muffler only**	2.047"	C	Top	4
12 786 03-S	Mounting/Guard Kit****	—	C	Top	4
12 068 11-S	Muffler only	2.047"	D	Starter	5
12 786 02-S	Mounting Kit***	—	—	Starter	5
12 755 26-S	Guard Kit	—	D	Starter	5

** Shown with deflector, not included.

*** Includes manifold, brackets, gaskets, hardware.

**** Includes manifold, brackets, exhaust deflector, gasket, guard, hardware.

B — From centerline of crank to top of muffler is 12.5"; to top of guard is 13"; to bottom of guard is 6". From PTO face to guard at farthest point is 5.5"; to muffler is 5".

C — From centerline of crank to top of guard is 18.5"; to top of deflector is 20.55".

D — From centerline of crank to left edge of guard is 11.25"; to left edge of muffler is 10.75".

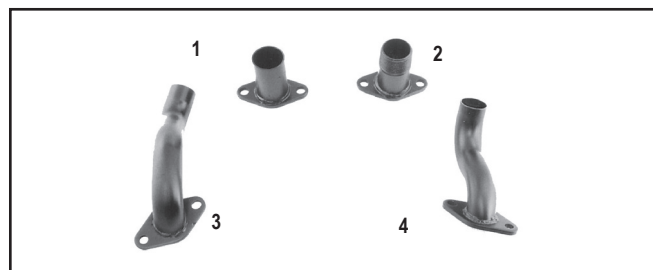

MANIFOLDS

Part No.	Outlet O.D.	Models	For Muffler	Item
12 164 03-S	1.312"	CH11-15	Various	1
12 164 04-S*	—	CH11-15	Pepperpot	2
12 164 05-S**	—	CH11-15	Pepperpot	3
12 382 01-S	1.125"	CH11-15	Ham Can, Top	3
12 382 03-S	1.125"	CH11-15	Ham Can, PTO	4

* 1.0" N.P.T. external thread.

** Same as 12 382 01-S, except 1.0" N.P.T. external thread.

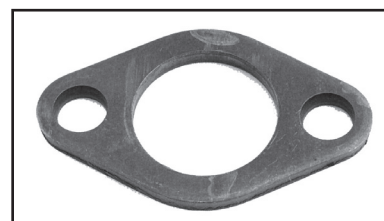

EXHAUST FLANGE (CH/CV11-15)

For adapting manifold length to customer-supplied exhaust.

Part No.	Description	Models
12 295 01-S	Steel, 0.188" thick	CH/CV11-15

Exhaust

MISCELLANEOUS MUFFLERS

CV Models

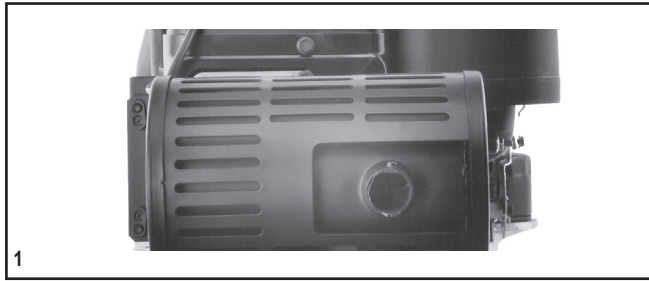

Part No.	Description	Engine Side	Outlet O.D.	Item
12 755 20-S*	Muffer Kit	Valve Cover	1.25"	1

* Includes integral guard. Muffer extends 7" from blower housing.

CH Models

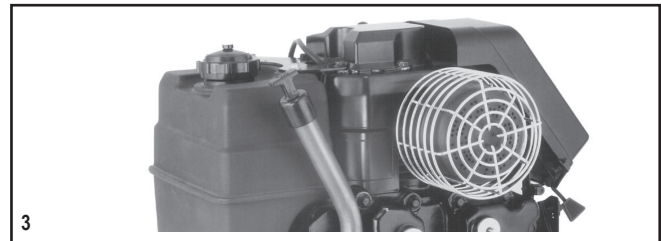
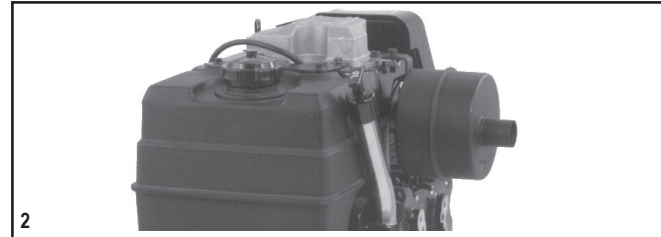

Kit No.	Muffer Only	Description (Ideal For)	Engine Side	Item
12 786 16-S*	12 068 58-S ^{&} (Aluminized)	Round (Compressors)	Top	1
12 786 20-S	12 068 51-S	Round (Press. Washers)	Above PTO	2
12 786 05-S**	275679-S	Pepperpot-Thread On	Above PTO	3
25 314 01-S	—	Guard only	—	3

* Includes angled oil fill tube and dipstick to clear muffer, plus mounting bracket and hardware. Muffer outlet is 5.5" above valve cover. Outlet O.D. is 1.25".

**Includes muffer, manifold, gasket, hardware. Muffer has 1.0" N.P.T. internal thread. Not usable if engine requires CARB/EPA certification.

[&] Aluminized steel canister.



Shown: 24 068 27-S Quiet version.
(Mufflers will fit with top-mount controls only).

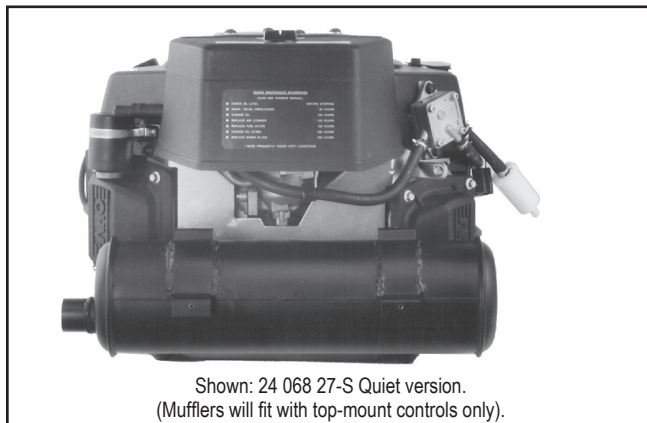

Shown: 24 068 27-S Quiet version.
(Mufflers will fit with top-mount controls only).

COMMERCIAL MOWER CANISTER MUFFLERS — HEAT SHIELDS REQUIRED. SEE BELOW.

Part No.	Outlet Location/Direction	Outlet O.D.	Muffler Diameter	Muffler Length	A	B	Models
24 068 09-S	Starter Side/Straight	1.375"	4.0"	12.0"	1.0"	4.75"	CV17-25/620-730,740,750,LV625-680
24 068 08-S	Filter Side/Straight	1.375"	4.0"	12.0"	1.0"	4.75"	CV17-25/620-730,740,750,LV625-680
24 068 20-S	Filter Side/Down	1.375"	4.0"	12.0"	1.0"	4.75"	CV17-25/620-730,740,750,LV625-680
24 068 21-S	Filter Side/Extended	1.375"	4.0"	12.0"	1.0"	4.75"	CV17-25/620-730,740,750,LV625-680

Note: For mounting, order (2) 24 041 49-S Gasket, (2) 24 072 08-S Stud, (2) M-641060-S Nut, (4) 25 100 52-S Nut.

QUIET CANISTER MUFFLERS — HEAT SHIELDS REQUIRED. SEE BELOW.

These mufflers are larger than those above, and also up to 4 dBA quieter (@3600 RPM, WOT).

Kit No.	Muffler Only	Outlet Location/Direction	Outlet O.D.	Muffler Diameter	Muffler Length	A	B	Models
—	24 068 25-S	Center/Straight	1.375"	4.62"	16.0"	1.0"	5.5"	CV17-25/620-730,740,750,LV625-680
—	24 068 27-S	Starter Side/Straight	1.375"	4.62"	16.0"	1.0"	5.5"	CV17-25/620-730,740,750,LV625-680
—	24 068 29-S	Filter Side/Straight	1.375"	4.62"	16.0"	1.0"	5.5"	CV17-25/620-730,740,750,LV625-680
—	24 068 28-S	Filter Side/Down	1.375"	4.62"	16.0"	1.0"	5.5"	CV17-25/620-730,740,750,LV625-680
—	24 068 26-S	Filter Side/Extended	1.375"	4.62"	16.0"	1.0"	5.5"	CV17-25/620-730,740,750,LV625-680
—	24 068 58-S [§]	Filter Side/Straight	1.375"	4.62"	16.0"	1.0"	5.5"	CV17-25/620-730,740,750,LV625-680
—	24 068 43-S	Center/Straight	1.375"	4.62"	16.0"	1.0"	5.5"	CV26/745EFI, ECV630-749, PCV680-740
24 786 28-S	24 068 45-S	Starter Side/Straight	1.375"	4.62"	16.0"	1.0"	5.5"	CV26/745EFI, ECV630-749, PCV680-740
24 786 29-S	24 068 47-S	Filter Side/Straight	1.375"	4.62"	16.0"	1.0"	5.5"	CV26/745EFI, ECV630-749, PCV680-740
24 786 30-S	24 068 46-S	Filter Side/Down	1.375"	4.62"	16.0"	1.0"	5.5"	CV26/745EFI, ECV630-749, PCV680-740

A — Mounting surface to bottom of muffler.

B — Mounting surface to top of muffler.

Note: For mounting, order (2) 24 041 49-S Gasket, (2) 24 072 08-S Stud, (2) M-641060-S Nut, (4) 25 100 52-S Nut.

[§]Aluminized steel canister.



HEAT SHIELDS FOR CANISTER MUFFLERS

Kohler requires a heat shield between muffler and air cleaner.

Part No.	Designed for Mufflers
24 281 06-S*	24 068 08-S, 09-S, 20-S, 21-S
24 314 51-S [§]	24 068 26-S, 27-S, 28-S, 29-S, 58-S
24 281 14-S*	24 068 25-S
24 281 15-S*	24 068 44-S, 45-S, 46-S, 47-S

*Order (4) 25 086 40-S Screws for mounting heat shield.

[§]Aluminized steel to match muffler.

Exhaust



1
FLAT AIR CLEANER

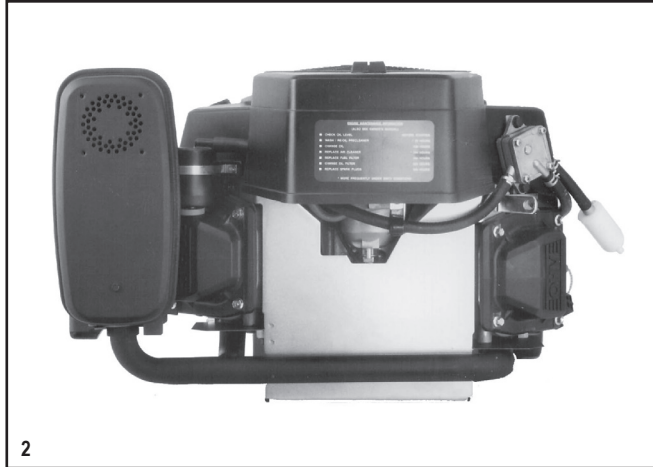

2
COMMERCIAL MOWER AIR CLEANER

VERTICAL MUFFLER KITS* (CV17-740,750)

Kit No.	Muffler Only	Location	Outlet D.B.C.	A	B	Item
24 786 13-S	24 068 19-S	Starter Side	3.06"	3.0"	3.5"	1 (Shown)
24 786 14-S	24 068 19-S	Filter Side	3.06"	3.0"	3.5"	1
24 786 15-S	24 068 22-S	Starter Side	3.06"	—	—	2 (Shown)
24 786 16-S	24 068 22-S	Filter Side	3.06"	—	—	2

*Includes muffler, manifold, brackets, heat deflector, clamp, gaskets, and hardware.

A — Extends forward of air cleaner.

B — Extends right (or left) of valve cover.

CROSSOVER MANIFOLDS USED IN KITS ABOVE

Part No.	Outlet Location	Outlet O.D.	Item
24 164 12-S	Starter Side, Down	1.125"	3
24 164 13-S	Filter Side, Down	1.125"	4
24 164 16-S	Starter Side, Up	1.125"	2
24 164 17-S	Filter Side, Up	1.125"	1

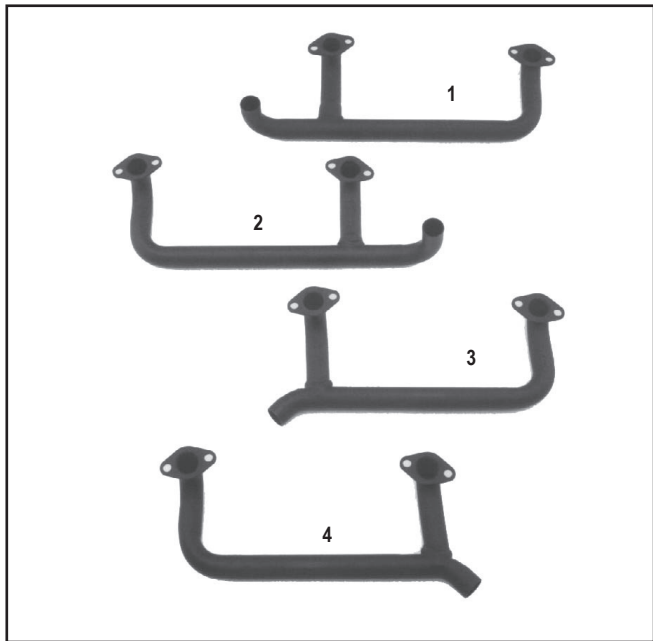

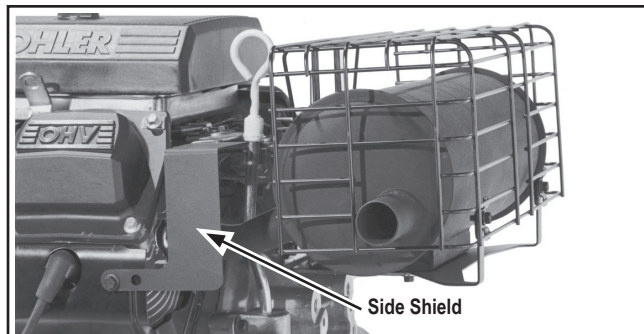
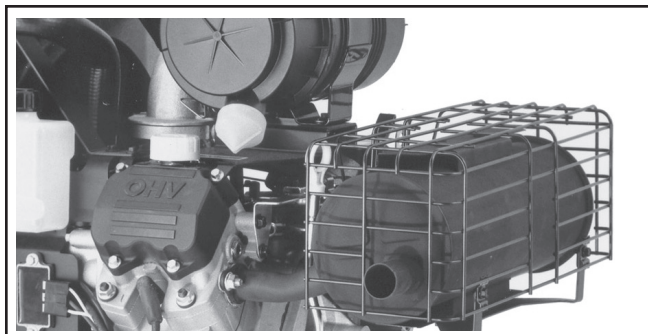

STANDARD PTO-CANISTER MUFFLER AND GUARD KITS

(not usable with 1" dia. metal oil fill tube)

Kit No.	Muffler Only	Outlet Location/Direction	Outlet O.D.	AEGIS		COMMAND		Models
				A	B	A	B	
24 786 04-S	24 068 05-S	Center/Straight	1.25"	—	—	4.5"	10.5"	CH18-22, CH620-680
24 786 05-S	24 068 07-S	Filter Side/Straight	1.25"	—	—	4.5"	10.5"	CH18-22, CH620-680
24 786 06-S	24 068 06-S	Starter Side/Straight	1.25"	—	—	4.5"	10.5"	CH18-22, CH620-680
24 786 23-S*	—	Starter Side/45° Down	1.25"	4.3"	10.3"	4.5"	10.5"	CH18-25, CH620-730, LH640-755
24 786 10-S**	24 068 12-S	Center/Straight	1.25"	4.3"	10.3"	4.5"	10.5"	CH25,730,740,750, LH640-755
24 786 11-S**	24 068 18-S	Filter Side/Straight	1.25"	4.3"	10.3"	4.5"	10.5"	CH25,730,740,750, LH640-755
24 786 12-S**	24 068 59-S&	Starter Side/Straight (Shown)	1.25"	4.3"	10.3"	4.5"	10.5"	CH25,730,740,750, LH640-755
24 786 26-S	24 068 57-S&	Filter Side/Straight	1.25"	4.3"	10.3"	4.5"	10.5"	CH25,730,740,750, LH640-755
24 755 80-S***	—	Muffler Guard Kit	—	—	—	—	—	CH18-26/620-750, LH640-775, ECH630-749, PCH680-740
24 755 114-S***	—	Side Shield Kit (2 Shields)	—	—	—	—	—	CH18-26/620-750 only (not LH), ECH630-749, PCH680-740
24 786 32-S	24 068 35-S*%	Filter Side/Straight	1.25"	4.3"	10.3"	4.5"	10.5"	CH26/745, LH775, ECH630-749, PCH680-740
24 786 33-S	24 068 41-S*%	Center/Straight	1.25"	4.3"	10.3"	4.5"	10.5"	CH26/745, LH775, ECH630-749, PCH680-740
24 786 31-S	24 068 42-S*%	Starter Side/Straight	1.25"	4.3"	10.3"	4.5"	10.5"	CH26/745, LH775, ECH630-749, PCH680-740

*CH25,26/730-750,LH640-775 require heat shield. **Includes heat shield and screws. See shields below.

***When Guard Kit 24 755 80-S and Shield Kit 24 755 114-S are used together, they meet EEC (European) standards for avoidance with hot surfaces.

%25 755 36-S Mounting Kit required for first time installation. &Aluminized steel canister.

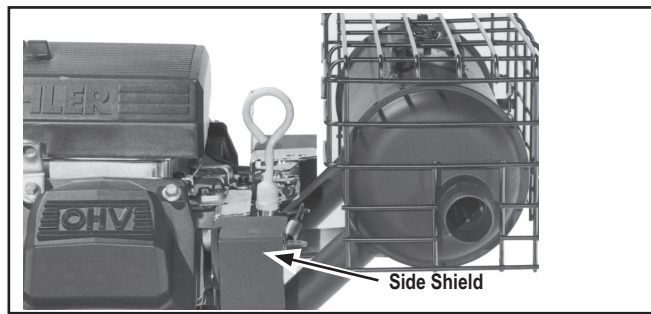
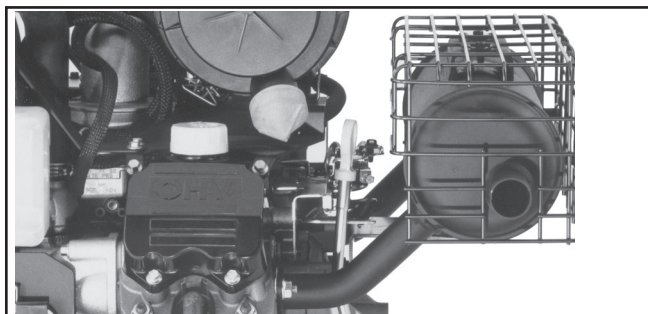

PTO-CANISTER MUFFLER AND GUARD KITS (IDEAL FOR GEN SETS)

Mufflers are same size as standard canisters (top of page), but have a raised body to clear the alternator assembly on a generator set. Note that there is no center outlet muffler because it would allow hot exhaust to blow directly at the generator set control box.

Kit No.	Muffler Only	Outlet Location/Direction	Outlet O.D.	AEGIS		COMMAND		Models
				A	B	A	B	
24 786 21-S*	24 068 36-S	Filter Side/Straight	1.25"	6.3"	13.1"	6.5"	13.25"	CH18-25/620-730,740,750, LH640-755
24 786 22-S*	24 068 37-S	Starter Side/Straight	1.25"	6.3"	13.1"	6.5"	13.25"	CH18-25/620-730,740,750, LH640-755
24 786 27-S	24 068 51-S	Filter Side/Straight	1.25"	6.3"	13.1"	6.5"	13.25"	CH26/745, LH775, ECH630-749, PCH680-740
25 786 02-S	24 068 60-S	Starter Side/Straight	1.25"	6.3"	13.1"	6.5"	13.25"	CH26/745, LH775, ECH630-749, PCH680-740
24 755 104-S**	—	Muffler Guard Kit	—	—	—	—	—	CH18-25/730-750, LH640-775, ECH630-749, PCH680-740
24 755 114-S**	—	Side Shield Kit (2 Shields)	—	—	—	—	—	CH18-25/730-750 only (not LH), ECH630-749, PCH680-740

* Includes only screws for attaching heat shield. (Required for CH25,26/730-750,LH690-775).

** When Guard Kit 24 755 104-S and Shield Kit 24 755 114-S are used together, they meet EEC (European) standards for avoidance with hot surfaces.

A - Centerline of crank to bottom of muffler. B - Centerline of crank to top of muffler.

Exhaust

HEAT SHIELDS FOR CANISTER MUFFLERS

Part No.	Designed for Mufflers
24 314 50-S* [‡]	24 068 12-S, 17-S, 18-S, 36-S, 37-S, 57-S
24 314 21-S**	24 068 35-S, 41-S, 42-S, 51-S

* (4) M-650012 screws for mounting heat shield are included in muffler kits, except for 24 786 23-S which requires screws to be ordered.

** Order (4) M-650012-S screws for mounting heat shield.

[‡] Aluminized steel to match muffler.

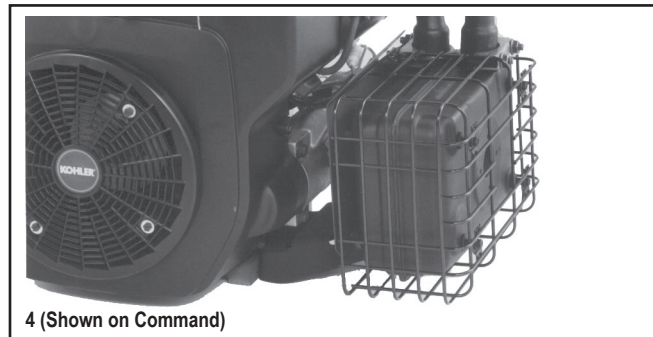
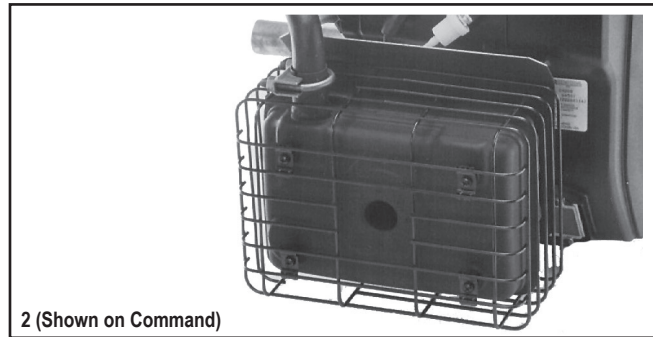
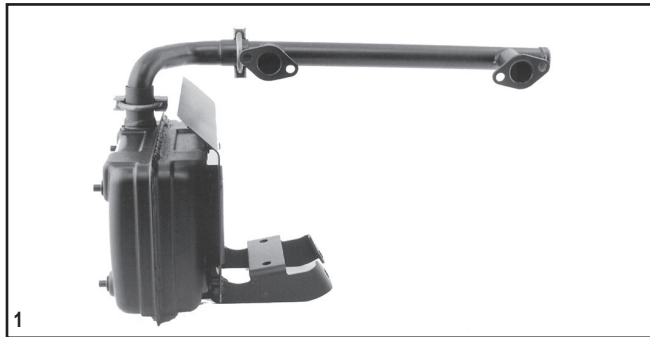
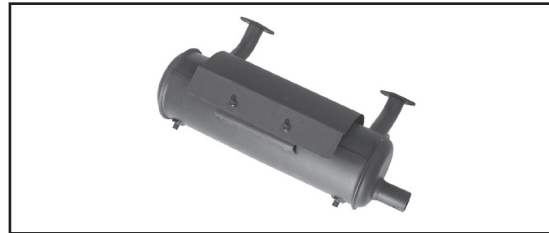

SIDE-MOUNT MUFFLER AND GUARD KITS (STANDARD)

(Not usable with 1" diameter metal or plastic oil fill tube)

Kit No.	Muffler Only	Location	Outlet D.B.C.	Models	Extends Engine Width By	Item
24 786 08-S	24 068 13-S	Starter Side	2.047"	CH18-23, 620-680	4.0"	1
24 786 09-S	24 068 14-S	Filter Side***	2.047"	CH18-23, 620-680*	4.0"	1 (Shown)
24 755 22-S	—	Guard Kit**	—	CH18-23, 620-680*	4.375"	2
24 786 19-S	24 068 30-S	Starter Side	2.047"	CH25/730,740,750, LH640-755*****	4.25"	3 (Shown)
24 786 20-S	24 068 31-S	Filter Side****	2.047"	CH25/730,740,750, LH640-755*****	5.60"	3
24 755 149-S	—	Guard Kit, Starter Side	—	CH25/730-750, LH640-755	4.25"	4 (Shown)
24 755 151-S	—	Guard Kit, Filter Side	—	CH25/730-750, LH640-755	5.60"	4
24 786 24-S	24 068 54-S	Starter Side	2.047"	CH26,745*****	4.25"	3
24 786 25-S	24 068 55-S	Filter Side****	2.047"	CH26,745, LH775*****	4.25"	3

* Not usable on models with oil cooler.

** Shown on 24 786 09-S Muffler Kit (muffler not included).

*** May also need to order 12 050 01-S Oil Filter to avoid interference with muffler.

**** Includes 12 050 01-S Oil Filter to avoid interference with muffler.

***** Kits include muffler and dual manifolds.

SIDE-MOUNT GUARD KITS, EEC (EUROPEAN) COMPLIANT

These kits include guards for the muffler, manifold and exhaust elbow. The guards must be used together to meet EEC standards for avoiding contact with hot surfaces.

Kit No.	Location	Extends Engine		Models
		Width	By	
54 755 25-S	Filter Side	4.375"		CH18-23,620-680
24 755 150-S*	Filter Side	4.375"		CH25/730,740,750 LH640-755
24 755 148-S*	Starter Side	4.375"		CH25/730,740,750 LH640-755

*Manifold guard is metal mesh, compared to wire form in other kits.

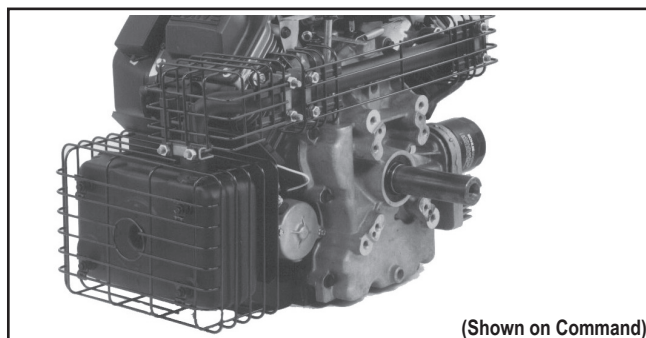

(Shown on Command)

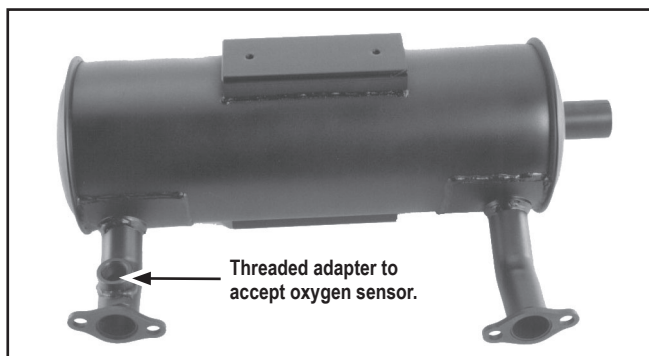

Threaded adapter to accept oxygen sensor.

PTO CANISTER MUFFLERS AND GUARD (Closed Loop LP Systems with Carburetors)

Mufflers include threaded adapter in filter-side inlet pipe, to accept oxygen sensor for closed loop LP fuel systems with carburetors.

Kit No.	Muffler Only	Location/Direction	Outlet	
			Outlet O.D.	Models
—	24 068 33-S*	Starter Side/Straight	1.25"	CH18-25,620-730
—	24 068 34-S*	Filter Side/Straight	1.25"	CH18-25,620-730
24 755 80-S	—	Wire Guard Kit	—	CH18-25,620-730

*Mufflers include brackets for attaching heat shield (required for CH25).

Order 24 314 50-S Heat Shield and (4) M-650012-S Screws.

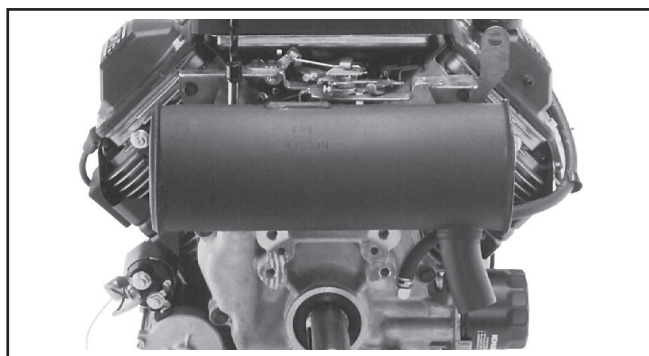

PTO CANISTER MUFFLER (Special Outlet Pointing Down)

Will not accept heat shield or wire guard kit. CARB/EPA compliant on CH18-22 only.

Part No.	Outlet		Models
	Direction	O.D.	
24 068 11-S	Down	1.375"	CH18-22*

*Application Engineering approval needed for CH25/730-740 and LH640-755 due to smaller muffler volume and potential for higher heat.

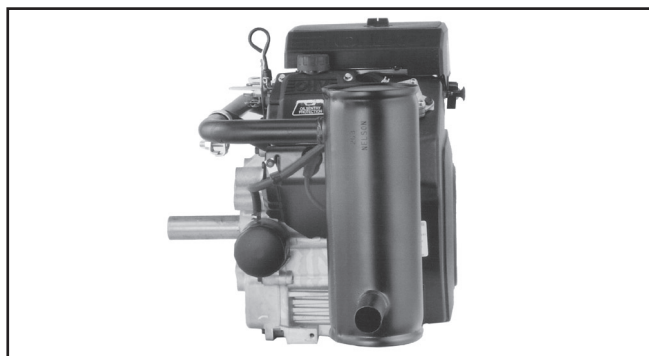

CANISTER MUFFLER (Remote and Vertical Orientation)

Available on filter side only (without oil cooler) and as remote. Special shielding is necessary (furnished by customer) to protect the fuel pump, whether specification has pulse or mechanical pump. If a mechanical pump is used on starter side, no shielding is necessary.

Part No.	Mounting		Outlet O.D.	Models
	Location			
24 068 15-S*	Remote Mount		1.375"	CH18-22,620-680
24 068 16-S**	Filter Side (shown)		1.375"	CH18-22,620-680
24 068 48-S***	Remote Mount			CH23-740

* Also order (1) 24 164 04 Manifold, (2) 24 041 49 Gasket, and (4) 25 100 52-S Nut.

** Same as above, plus: (1) 12 237 02 Clamp, (1) M-839020 Screw (bracket to crankcase), and (1) M-651030 Screw (bracket to valve cover).

*** Also order (1) 24 164 27 Manifold, (2) 24 041 49 Gasket, and (4) 25 100 52-S Nut, (1) 47 237 04-S Clamp, (1) M-651030 Screw (bracket to valve cover), and 24 314 43-S Heat Shield. Customer supplies mounting bracket.

Exhaust



CROSSOVER MANIFOLDS

Part No.	Outlet Location	Outlet	Extends From PTO Face	Models	Item
Single Manifolds					
24 164 04-S	Filter Side	1.11" (O.D.)	0.75" Outside Face	CH620-680	1
24 164 03-S	Starter Side (Fits duct package)	1.11" (O.D.)	2.125" Outside Face	CH620-680	1
24 164 10-S	Starter Side (For side muffler)	1.11" (O.D.)	0.25" Inside Face	CH620-680	1
24 164 11-S	Filter Side (For side muffler)	1.11" (O.D.)	0.25" Inside Face	CH620-680	1
24 164 27-S****	Filter Side	1.24" (O.D.)	0.25" Inside Face	CH730-742,750, LH640-755	1
24 164 28-S****	Starter Side	1.24" (O.D.)	0.25" Inside Face	CH730-742,750, LH640-755	1
24 164 25-S	Center*	1.468" (O.D.)	6.5" Outside Face	CH26/745, LH775	2
Dual Manifolds					
24 164 19-S	Starter Side (For side muffler, cyl. #1)**	1.26" (I.D.)	0.25" Inside Face	CH25/730-750, LH640-755	3
24 164 20-S	Starter Side (For side muffler, cyl. #2)**	1.26" (I.D.)	0.25" Inside Face	CH25/730-750, LH640-755	3
24 164 21-S	Filter Side (For side muffler, cyl. #2)***	1.26" (I.D.)	0.25" Inside Face	CH25/730-750, LH640-755	3
24 164 22-S	Filter Side (For side muffler, cyl. #1)***	1.26" (I.D.)	0.25" Inside Face	CH25/730-750, LH640-755	3

* Includes port for Oxygen Sensor (24 418 05-S, not included). To be CARB/EPA certified, must have Kohler Application Engineering approval when non-Kohler exhaust components are used.

** Included in the 24 786 19-S Side-Mount Muffler Kit.

*** Included in the 24 786 20-S Side-Mount Muffler Kit.

**** Will not fit with straight dipstick tube. Offset Dipstick Tube or Kit 24 755 121-S required.

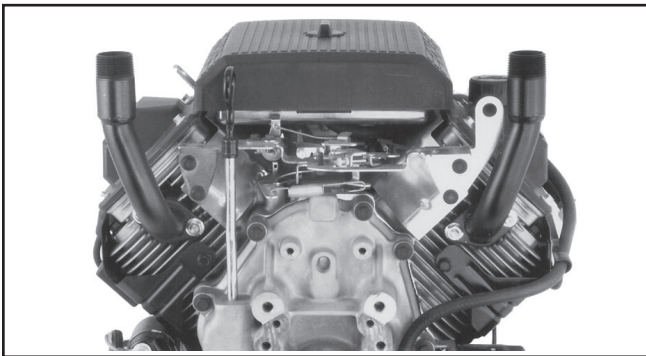

90° MANIFOLD KIT

Kit No.	Fits Muffler	Thread	Models
24 730 01-S	275679-S	1" N.P.T.	CH18-25/730-750, LH640-755

Kit includes (2) Elbows, (2) Gaskets, (4) Nuts. No interference with PTO face.

OXYGEN SENSOR FITTING

EFI Repowers

Part No.	Description
25 294 33-S	Fitting, M18 x 1.5
25 294 53-S	Hex Fitting, 12 mm x 1.25

OXYGEN SENSOR PLUG KIT

Plugs O₂ sensor hole in EFI muffler for use on Command carbureted engine.

Part No.
24 139 09-S

*Indicates item not usable on engines which are required to meet CARB or EPA emission regulations, unless approved by Kohler for specific applications.



STUB MANIFOLDS

Kit No.	Outlet O.D.	Models
124 164 05-S	1.415"	CH18-25/730-750, LH650-775



STUB MANIFOLD

Part No.	Outlet O.D.	Models
62 164 12-S	1.5"	CH940-1000

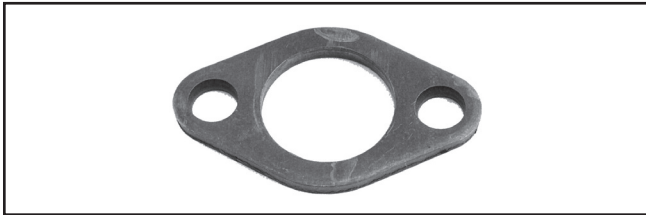

EXHAUST FLANGE

For adaptation of customer-supplied exhaust.

Part No.	Description	Models
24 295 01-S	Steel, 0.188" thick	CH/CV17-25/730-750, LH640-775



EXHAUST FLANGE

For adaptation of customer-supplied exhaust.

Part No.	Description	Models
62 295 01-S	Steel, 0.25" thick	CH940-1000



EXHAUST PORT LINER

Offers better thermal protection.

Part No.	Description	Models
24 605 07-S	Stainless Steel, 0.035" thick,	CH/CV17-25/730-750, LH640-775, ECH/ECV630-749



EXHAUST PORT LINER

Offers better thermal protection.

Part No.	Description	Models
62 605 07-S	Stainless Steel, 0.030" thick	CH940-CH1000 CV940-CV1000 ECV940, ECV980

*Indicates item not usable on engines which are required to meet CARB or EPA emission regulations, unless approved by Kohler for specific applications.

Exhaust

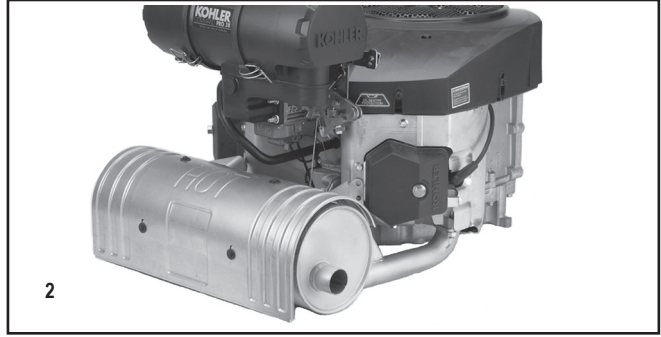
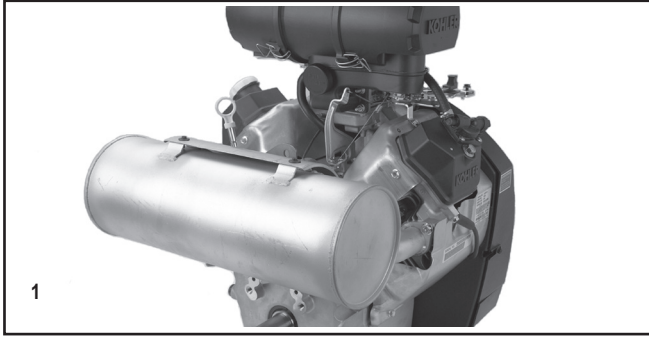

CH940-CH1000 MUFFLER KITS*

Kit No.	Muffler Only	Discharge	Outlet O.D.	A	B	Item	Heat Shield (required)
62 786 01-S	62 068 06-S	Center	1.5"	11.75"	4.0"	1	62 314 05-S
62 786 02-S	62 068 05-S	Starter Side	1.5"	11.75"	4.0"	1	62 314 05-S
62 786 03-S	62 068 02-S	Opposite Starter	1.5"	11.75"	4.0"	1	62 314 05-S

*Includes muffler, gaskets, heat shield, and hardware.

A — Centerline of crank to top of muffler.

B — Centerline of crank to bottom of muffler.

TIER III EXHAUST (SAI)

Part No.	Discharge
62 068 19-S	Left Outlet (opposite starter)
62 068 27-S	Center Outlet
62 068 28-S	Right Outlet (starter side)

CV940-CV1000 MUFFLER KITS*

Kit No.	Muffler Only	Discharge	Outlet O.D.	Item	Heat Shield (required)
62 786 04-S	62 068 09-S	Center	1.5"	2	62 314 06-S
62 786 05-S	62 068 08-S	Starter Side	1.5"	2	62 314 04-S
62 786 06-S	62 068 07-S	Opposite Starter	1.5"	2	62 314 04-S

*Includes muffler, brackets, gaskets, heat shield, and hardware.

ECV940, ECV980 MUFFLER KITS*

Kit No.	Discharge
62 786 08-S	Center
62 786 09-S	#1 Cylinder Side
62 786 10-S	#2 Cylinder Side

*Includes muffler, brackets, gaskets, heat shield, and hardware.

ECH940, ECH980 MUFFLER KITS*

Kit No.	Muffler Only	Discharge	Heat Shield (required)
62 786 13-S	62 068 16-S	Opposite Starter	62 314 11-S
62 786 14-S	62 068 17-S	Starter Side	62 314 11-S
62 786 15-S	62 068 18-S	Center	62 314 11-S

*Includes muffler, brackets, gaskets, heat shield, and hardware.

CROSSOVER MANIFOLDS AND MUFFLER

Original Equipment Manufacturer responsible for the original installation and thermal protection.

Kit No.	Models	Description	Location	Outlet O.D.	Inlet I.D.	
62 164 10-S	CH940-1000	Manifold	Non-Starter Side	1.5"	—	Not Pictured
62 164 11-S	CH940-1000	Manifold	Starter Side	1.5"	—	Not Pictured
62 068 10-S	CH940-1000	Muffler	—	—	1.5"	Not Pictured
62 786 07-S*	—	—	—	—	—	Not Pictured

*Includes 62 068 10, 62 164 10, 62 164 11, Gaskets, and Hardware.

ECV850-ECV880 MUFFLER KITS*

Kit No.	Muffler Only	Discharge	Item
19 786 01-S	19 068 01-S	#2 Cylinder Side	3
19 786 02-S	19 068 02-S	#1 Cylinder Side	3
19 786 03-S	19 068 03-S	Center	3
19 786 05-S	—	Filter Side	3

*Includes muffler, brackets, gaskets, heat shield, and hardware.

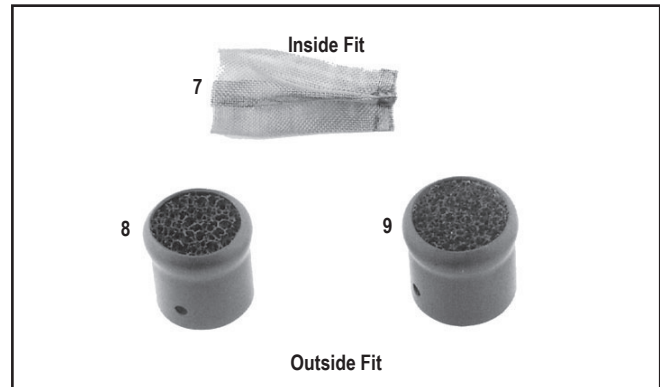
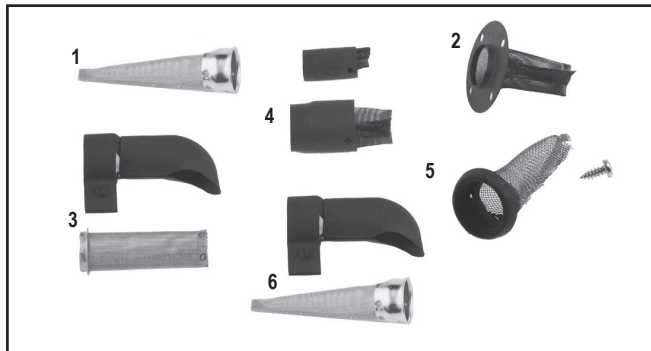
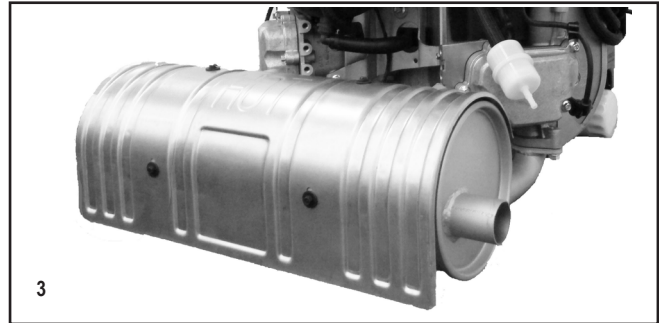

SPARK ARRESTORS

Part No.	Models	HP Rating For U.S.F.S.	Inlet Size	Fits Muffler Outlet	Mounting D.B.C.	Notes	Item
63 189 02-S	CS4-6	6	—	—	—	Already factory-installed on engine	1
63 189 01-S	CS8.5-12	12	—	—	—	Already factory-installed on engine	1
12 189 02-S*	CH/CV11-16/460-493, CH18-25/730-740, LH640-755, SV470-620	27	1.125" O.D.	1.126" I.D.	2.047"	For pillow side muffler	2
24 189 01-S	CH18-26/730-750, LH640-775,	31	1.26" I.D.	1.25" O.D.	—	For canister muffler, inc. deflector	3
25 189 01-S	CH/CV11-16/460-493, CH18-26/730-750, LH640-775	27	1.26" I.D.	1.25" O.D.	—	Includes set screw	4
25 189 02-S	CH/CV17-26/730-750, LH640-775, LV625-680	27	1.39" I.D.	1.375" O.D.	—	Includes set screw	4
62 189 02-S	CH940-1000	40	—	—	—	Includes set screw	—
62 533 01-S	CH940-1000	40	—	—	—	For canister muffler, inc. deflector	6
14 533 01-S	XT-6/7	27	—	—	—	Already factory-installed on engine	5
17 533 09-S	CH270	27	—	—	—	Already factory-installed on engine	2
18 533 02-S	RH265	—	—	—	—	—	6

* Also order (4) M-545010-S Screw (drill 5/32" holes in muffler).

EXHAUST SILENCERS

Part No.	Models	HP Rating For U.S.F.S.	Inlet Size	Fits Muffler Outlet	Notes	Item
52 428 01-S	Varies by outlet size	****	—	1.375" O.D.	Use 52 086 20-S Screw	7
25 755 08-S	Varies by outlet size	****	—	1.25" O.D.	Includes screw	8
25 755 09-S	Varies by outlet size	****	—	1.375" O.D.	Includes screw	9

****Not U.S.F.S. approved.

Exhaust

EXHAUST DEFLECTORS

Part No.	Models	Inlet I.D.	Fits Muffler Outlet	Also Order	Item
45 054 21-S	CH/CV17-26/730-750, LH640-775, LV625-680	1.376"	1.375" O.D.	D	1
25 054 05-S	CH/CV940-1000,	1.55"	1.50" O.D.	D	1
12 054 02-S	CV11-16/460-493, CH18-26/730-750, LH640-775	1.26"	1.25" O.D.	B	2
24 265 06-S	CH/CV17-26/730-750, LH640-775, LV625-680	1.39"	1.375" O.D.	B	3
24 265 07-S	CS8.5 (300cc), CS10-12, CH/CV17-26/730-750, LH640-775, LV625-680	1.39"	1.375" O.D.	B	4
63 265 01-S	CS4-6	1.02"	1.0"	E	5
63 265 02-S	CS8.5 (250cc)	1.96"	1.94" O.D.	E	5
24 265 01-S	CH/CV11-16/460-493, CH18-26/730-750, LH640-775	1.25"	1.25" O.D.	—	6
15 265 02-S	CH6	—	1.57" D.B.C.	A	7
12 755 106-S*	CH/CV11-16/460-493, CH18-25/730-740**, LH640-755, SV470-620	—	2.047" D.B.C.	—	8
12 755 28-S*	CH/CV11-16/460-493, CH18-25/730-740, LH640-755, SV470-620	—	2.047" D.B.C.	—	9
25 755 19-S*	CH/CV11-16/460-493, CH18-25/730-740, LH640-755, SV470-620	—	2.047" D.B.C.	—	10
24 755 49-S*	CH/CV17-750	—	3.06" D.B.C.	—	11
24 755 168-S*	CH/CV17-750	—	3.06" D.B.C.	—	12
62 265 03-S	CH940-1000	—	1.50" O.D.	—	—
18 730 01-S	SH265	—	—	—	13
17 730 05-S	CH270	—	2.01" D.B.C.	—	14
17 730 03-S	CH395/440	—	2.05" D.B.C.	—	15
18 123 19-S	2000 Series	—	—	—	—

*Kit includes deflector, screws.

**Minor modifications are needed to Muffler Guard 24 755 22-S if deflector is used with it.

A — (2) M-556010-S Screw
D — (1) 24 237 13-S Clamp

B — (1) 47 237 04-S Clamp
E — (1) 25 086 46-S Screw

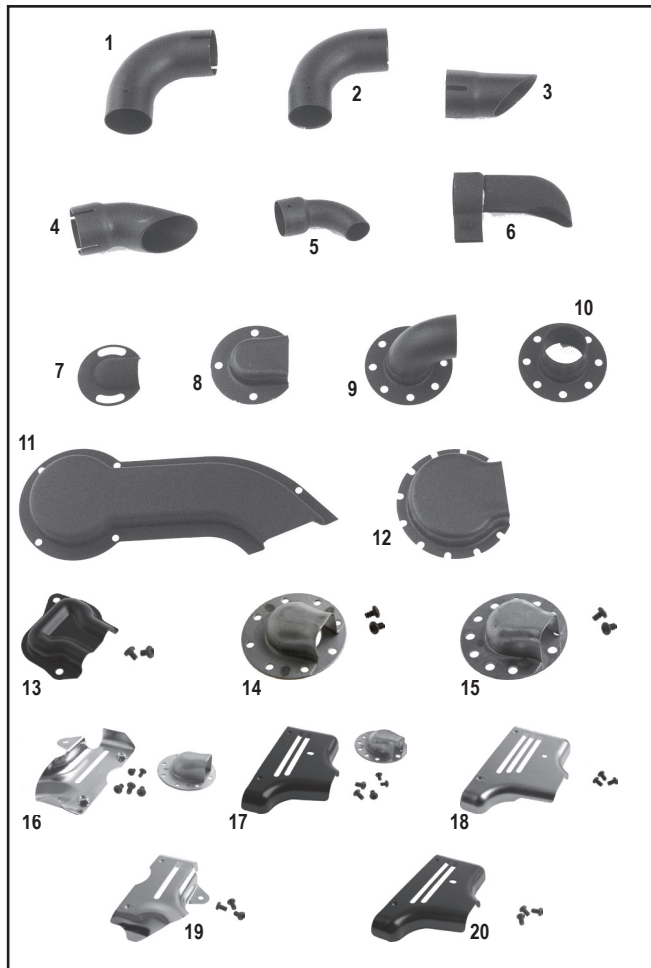

SHIELD KITS

Part No.	Models	Inlet I.D.	Fits Muffler Outlet	Item
17 730 01-S	CH270	—	2.01" D.B.C.	16
17 730 02-S	CH395	—	2.05" D.B.C.	17

PIPE PROTECTORS

Part No.	Models	Inlet I.D.	Fits Muffler Outlet	Item
17 730 04-S	CH440	—	—	18
17 730 06-S	CH270	—	—	19
17 730 08-S	CH395	—	—	20

HARDWARE KITS

For attaching mufflers to exhaust outlets.

Kit No.	Models	Includes	Item
12 786 17-S	CH/CV11-16/460-493	2 nuts, 1 gasket	1
25 786 01-S	CH18-26/730-750, LH630-775 w/standard flange nuts (shown)	4 nuts, 2 gaskets	2
17 786 01-S	CH270	3 screws, 1 gasket	3
17 786 02-S	CH395/440	3 screws, 1 gasket	3



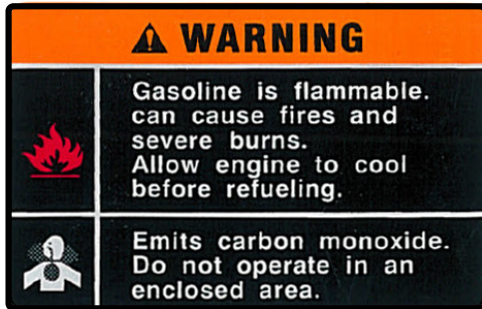

Part No. 14 113 57-S



Part No. 63 113 06-S



Part No. 25 113 33-S

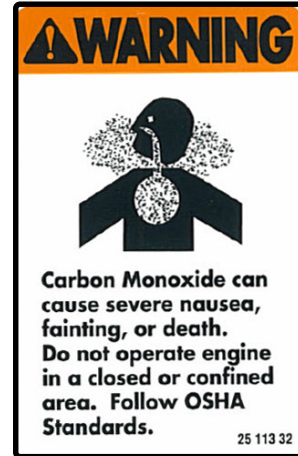

Part No. 25 113 32-S



Part No. 24 113 78-S

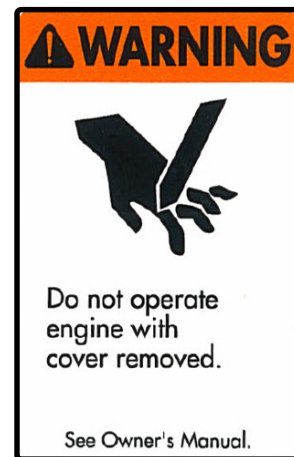

Part No. 66 113 01-S



Part No. 24 113 18-S

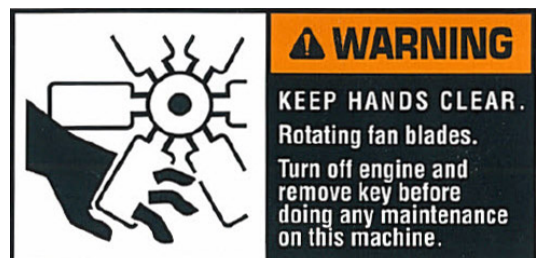

Part No. 66 113 04-S

For more information, contact your KOHLER source of supply.
Or call toll-free in the U.S. and Canada 800-544-2444.

KOHLER[®]
IN POWER. SINCE 1920.

KOHLERPOWER.COM

PRINTED IN U.S.A. 25 800 148 REV. D 9/17 © 2017 KOHLER CO.