

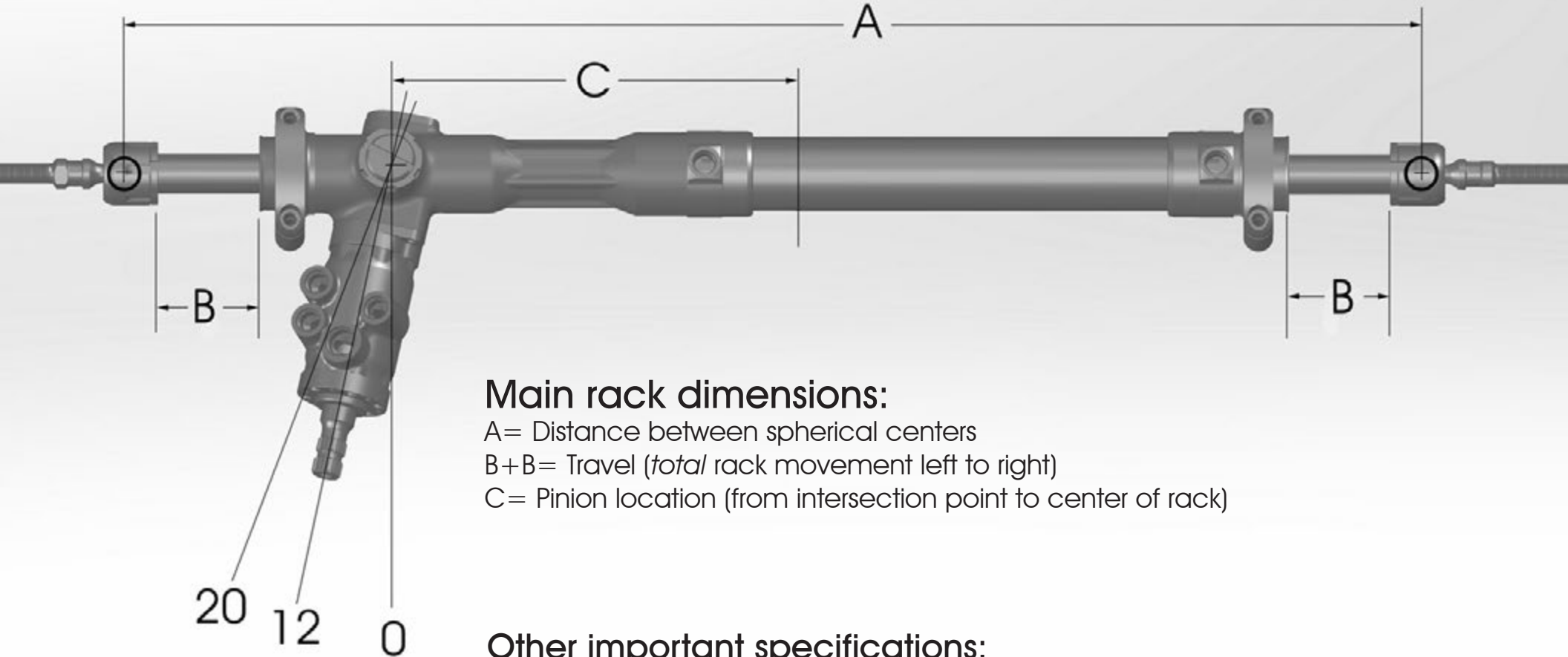

Data needed to quote a type CF custom rack

Use inch or mm dimensions



Main rack dimensions:

A= Distance between spherical centers

B+B= Travel (*total* rack movement left to right)

C= Pinion location (from intersection point to center of rack)

Other important specifications:

Pinion angle (to the left or right; options are 0, 12 or 20 degrees)

Ratio (distance the rack must move *in one turn*; options are [inch/mm]:

1.57/40, 1.83/47, 2.09/53, 2.36/60, 2.62/67, 2.88/73 ou 3.14/80

Changing out the torsion bar (applies to all servos with splined output shaft)

1. Remove the plug screws and their O-rings (requires 3/16 hex key).
2. Remove the centering/adjusting set screws (requires 5/32 or 4mm hex key). Note that with these screws removed there will be about ten degrees rotational play between the input and output shafts. It is essential that the screws be checked between races against loosening from vibration. ANY free play in the torsion bar connection will cause the [steering](#) to wander.
3. Remove the anchor set screw (requires 5/32 or 4mm hex key) *Caution:* the anchor set screw is TIGHT. Use a new, unworn hex key and pad your hand with a shop rag to avoid injury when the set screw breaks loose.
4. Install a 1/4-28 x 2 bolt in the end of the torsion bar. Using this bolt as a handle, extract the torsion bar (preferably toward the output end) while *carefully* easing the O-rings past the set screw holes.
5. The diameter of the T-bar is marked on the end with the two flats. A smaller bar gives lighter steering and a larger bar gives heavier steering.
6. Install a T-bar by reversing the sequence. Be careful not to cut the O-rings when pushing them past the hole. The O-rings prevent spiral leakage around the screws. Be sure the flats are aligned directly under their respective set screws.

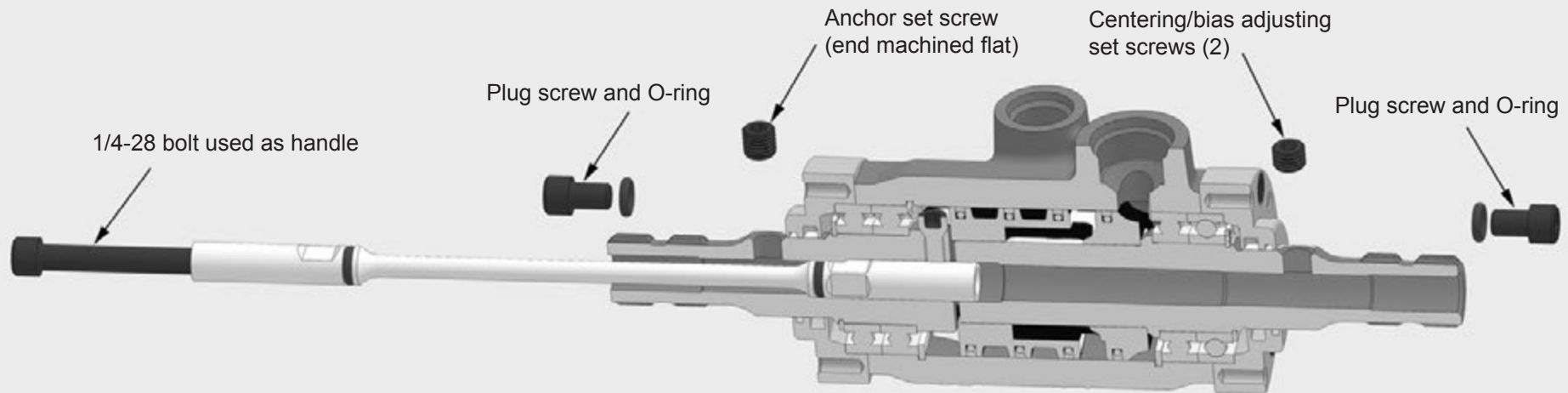

7. Seat the anchor screw squarely on its flat and tighten it enough that it will make a hard “snap” when broken loose. Blue Loctite® 242 or 243 may be used on the threads.
8. Install the two adjusting screws to approximately equal depth and snug them against the T-bar After the servo is installed in the car these screws will be used to set the neutral or centered position of the valve as described on the next page.

To center the steering (or to adjust the directional bias) The two set screws at the input end of the servo jack against the two flats on the torsion bar as illustrated in the cutaway views below. With the car off the ground, the neutral or centered position of the valve can be quickly determined by trial settings until the steering does not drift with the engine running. On oval track cars with unequal caster it may be advantageous to bias the steering. For example, on dirt where the car is countersteered most of the time, less muscular effort will be needed if the neutral point is offset to the right.

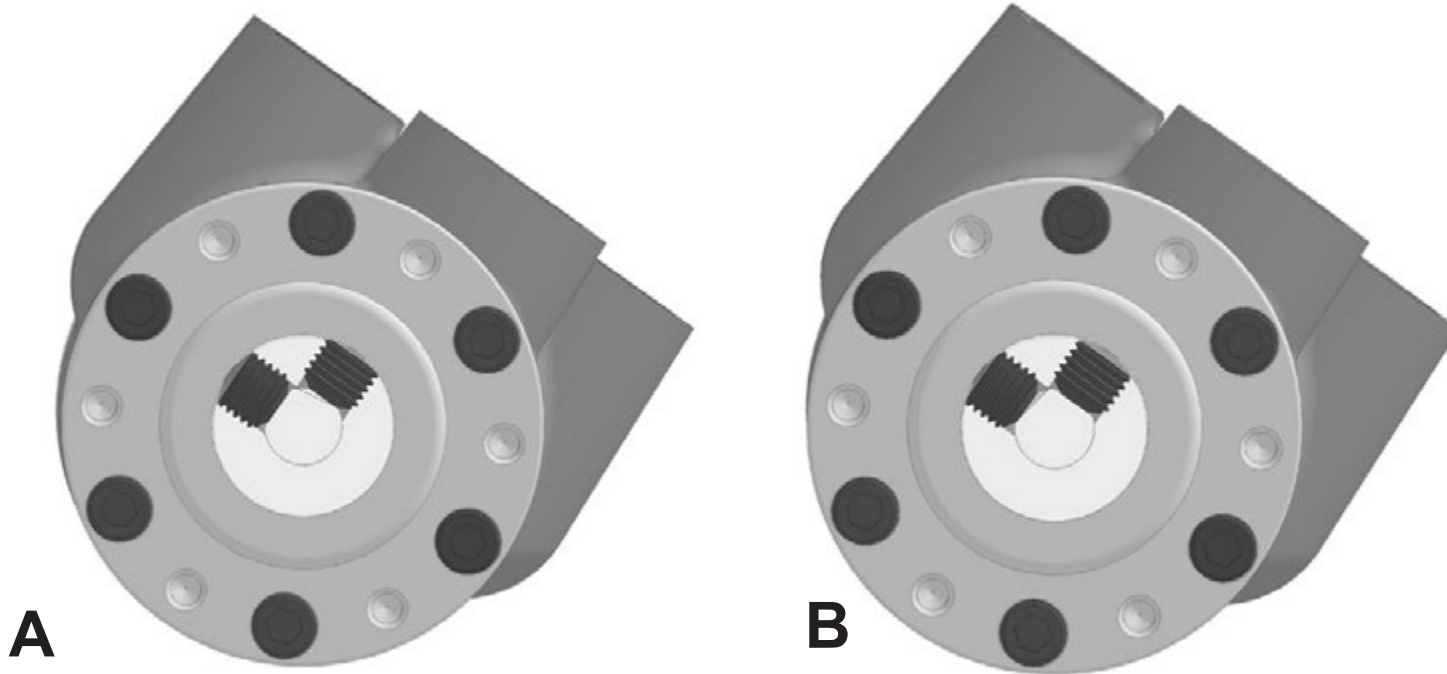

(Note: left and right are as seen by the driver, assuming the screws are visible from above. If the adjustment is done from underneath, left and right will be reversed)

View **A** shows the left screw all the way in and the right screw against the top of its ramp. In this position the steering will go all the way to right lock by itself as soon as the engine is started. View **B** shows the opposite adjustment, with the right screw all the way in. It will take off to the left. The available range is fairly large and will allow hands-off steering with as much as 10 degrees of caster stagger. It will also allow the steering to be perfectly centered using a single-rod cylinder where the blind side can be as much as 25% more powerful owing to the extra piston area not occupied by a rod.

When centering the steering for the first time, it is best to try large changes which will make the correction very obvious. When approaching center, only small adjustments should be taken until you cannot make the steering drift either direction by flicking the steering wheel. A 1/12 turn of the wrench (the distance between numbers on a clock face) will make a difference. Remember that BOTH set screws must be locked tight against the torsion bar. Check the screws between races; any play will cause the steering to wander and vibrate. A separate locking collar, p/n V588, can be used to secure the set screws. If you apply Loctite®, use only blue 242 or 243, or the green wicking 290. *Caution: DO NOT adjust the directional bias while the engine is running.*

Changing the torsion bar in the type CF servovalve

The principal difference between the CF type and other Woodward servos is that the anchor screw is covered by the CF pinion bearings. To access the set screw, the pinion assembly must be removed and the bearings pressed off. *Removing the pinion is not difficult if these steps are followed and the cautions observed.*

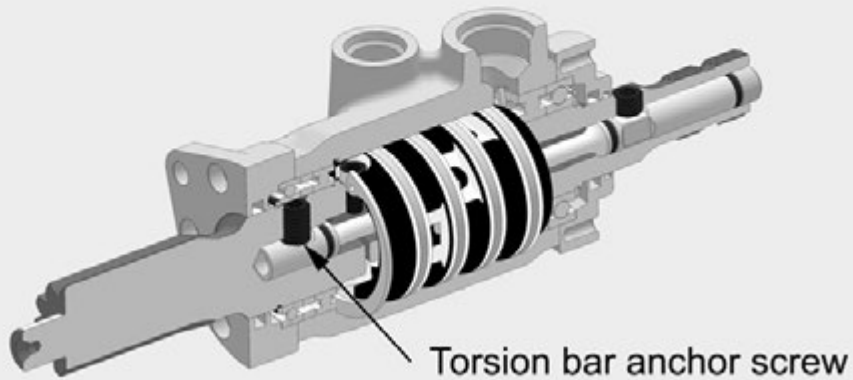

CAUTION before attempting disassembly:

When the right centering screw is aligned parallel to the nearest fluid port, the spool drive bolt inside the valve will be centered on the gap in the snap ring. Maintain this alignment while removing the pinion assembly. If the drive bolt cannot pass through it will damage the housing.

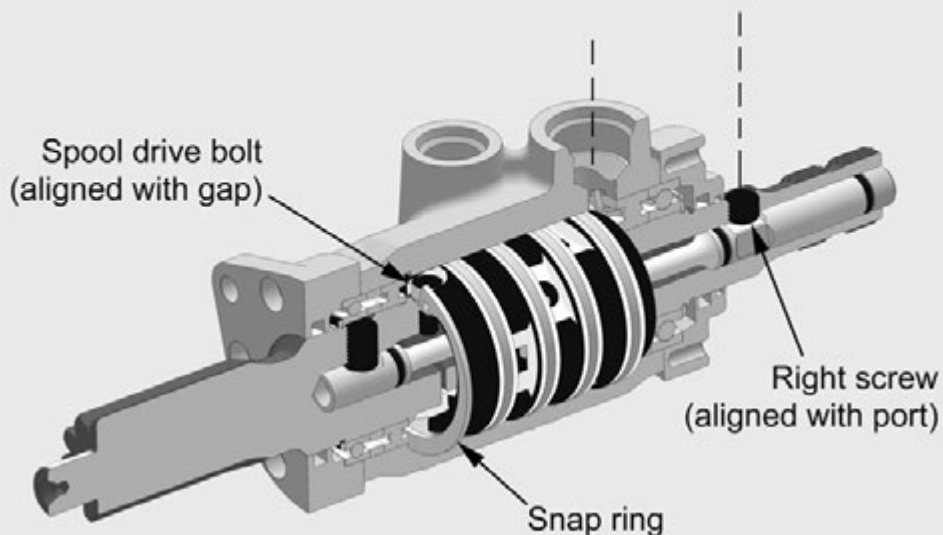

1. Remove the servo from the steering rack

The flange bolt holes (arrow) are lined with eccentric bushings which positively locate the pinion and maintain the gear lash adjustment. *To preserve the adjusted position, do not disturb the lower bearing cap; leave it bolted to the rack housing.*

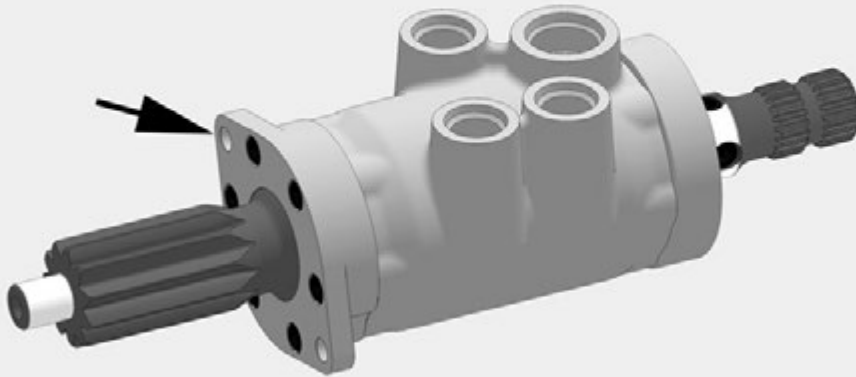

NOTE: the number of teeth on the pinion, its helix angle and hand, and the orientation of the hose ports relative to the mounting flange may be different from these illustrations, but the procedure for changing out the valve torsion bar is the same for all CF models.

2. Remove the mounting flange

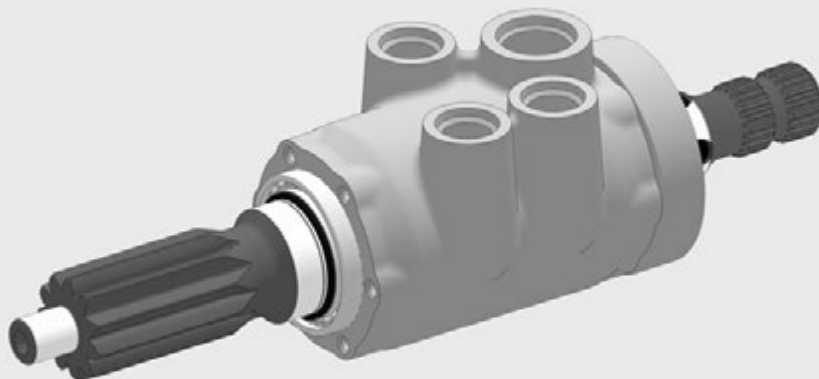

Mark its position for reassembly.

3. Remove the centering screws and the plug screw

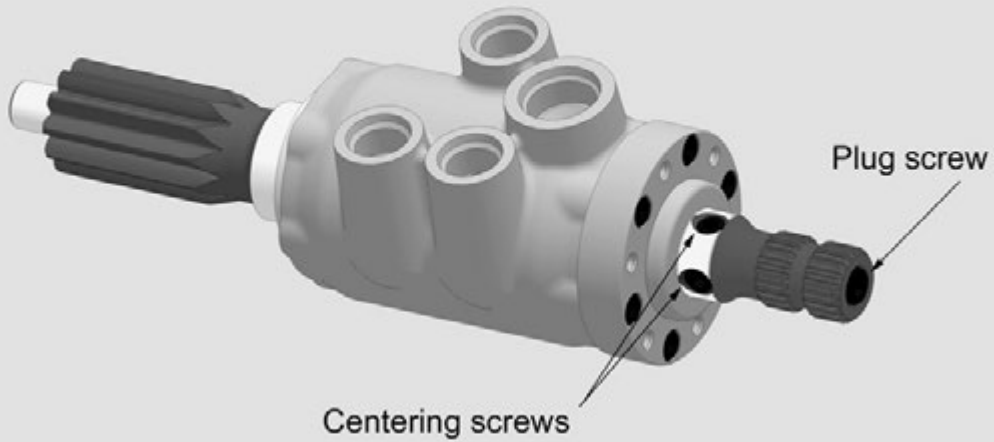

3a. Remove the plug O-ring
(if it did not come out with the plug screw)

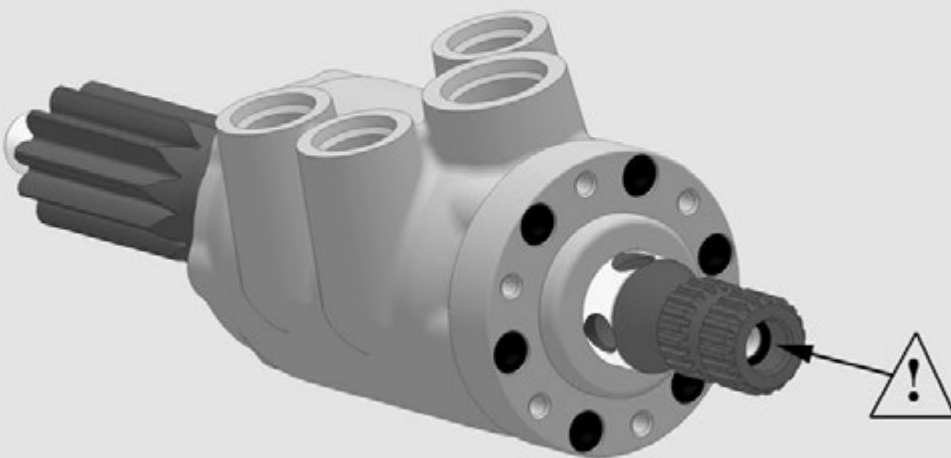

4. Install a 1/4-28 x 2 bolt in the end of the torsion bar

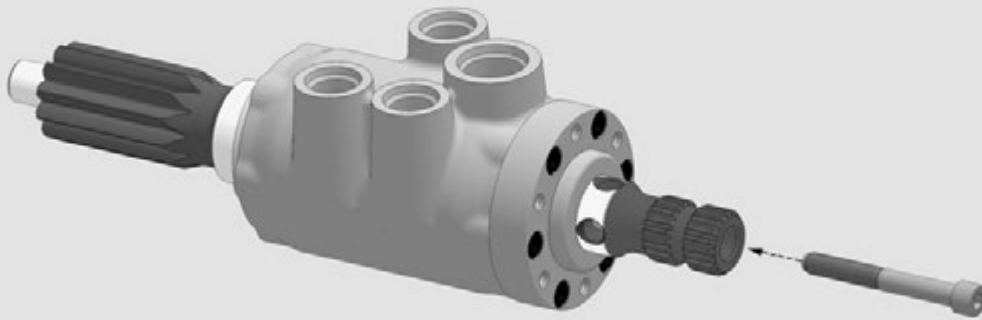

5. Press (or drive) the pinion assembly out of the housing

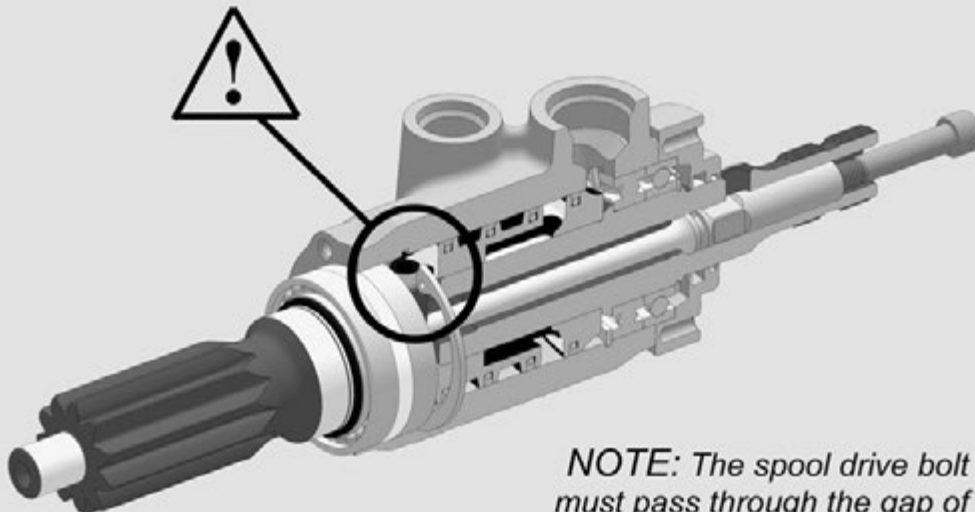

NOTE: The spool drive bolt must pass through the gap of the large snap ring in the housing!

6. When the pinion is free of the housing, remove the bolt

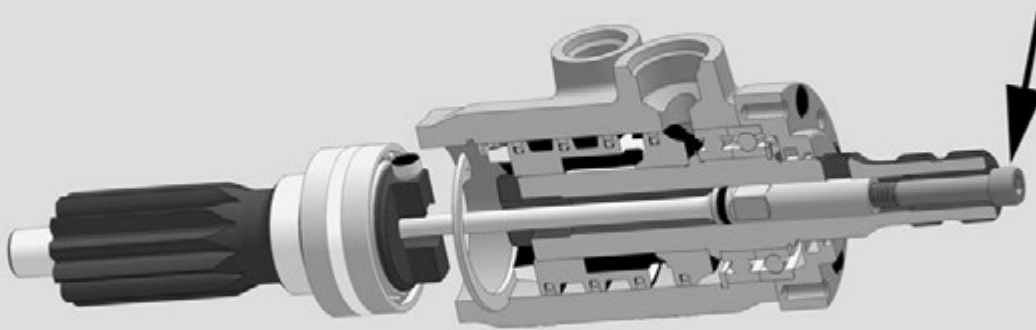

7. Press off the bearings and remove the anchor screw. The T-bar will pull easily out of the pinion.

Torsion bar diameters for the CF servovalve are .175, .180, .185, .190, .195, .200, .205, .210, .215, 220, and .225. The torsion bars from other types of Woodward servos such as Inline, HE and MR will not fit the CF.

To reassemble, reverse the steps. After the rack is reinstalled in the car it will be necessary to rebalance or recenter the valve (see step 8).

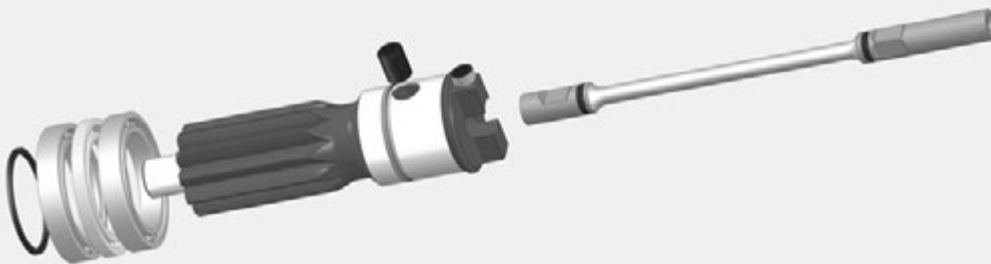

(The ball bearings shown are representative but will vary according to the pinion used in the rack.)

8. Recentering: The valve may be easily balanced by adjusting the screws until a position is found where the steering does not drift, *with the engine running and the wheels off the ground*. You can speed up the process by presetting the screws to approximately equal depth while the rack is still on the bench.



8a. Recentering: The set screws jack against the two flats or ramps on the torsion bar as shown in the cutaway views below:

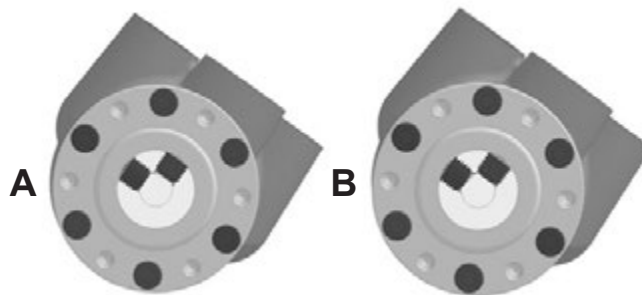

In view **A** the **left screw is all the way in** and the right screw is against the top of its ramp. This position will send the steering **all the way to right lock** as soon as the engine is started. View **B** shows the opposite adjustment, with the **right screw all the way in**, which will send it to the **left**. When adjusting for the first time, it is best to try large changes which will produce a very obvious result. As your setting approaches neutral, make very small adjustments until you cannot make the steering drift either direction by flicking the steering wheel. When that point is reached the steering is balanced. Last, remember to tighten **BOTH** set screws securely against the torsion bar, as any play will cause the steering to wander. Check the screws between races. A separate locking collar, p/n V588, can be used to further secure the set screws. If you apply Loctite®, use only blue 242 or 243, or the green wicking 290. **CAUTION: NEVER ADJUST THESE SCREWS WHILE THE ENGINE IS RUNNING.**

Clevis Rackshaft and associated parts

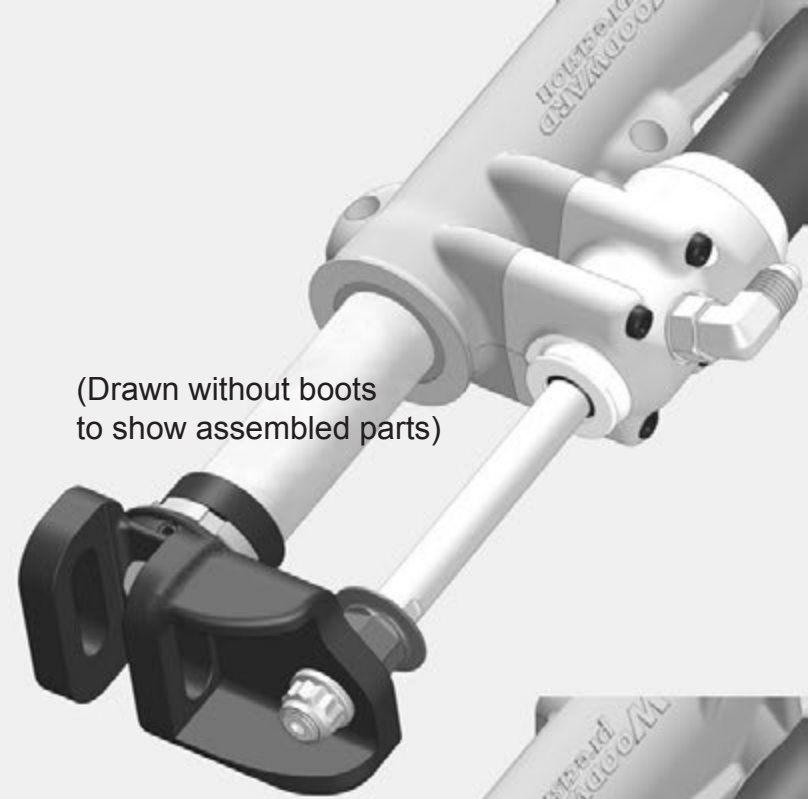
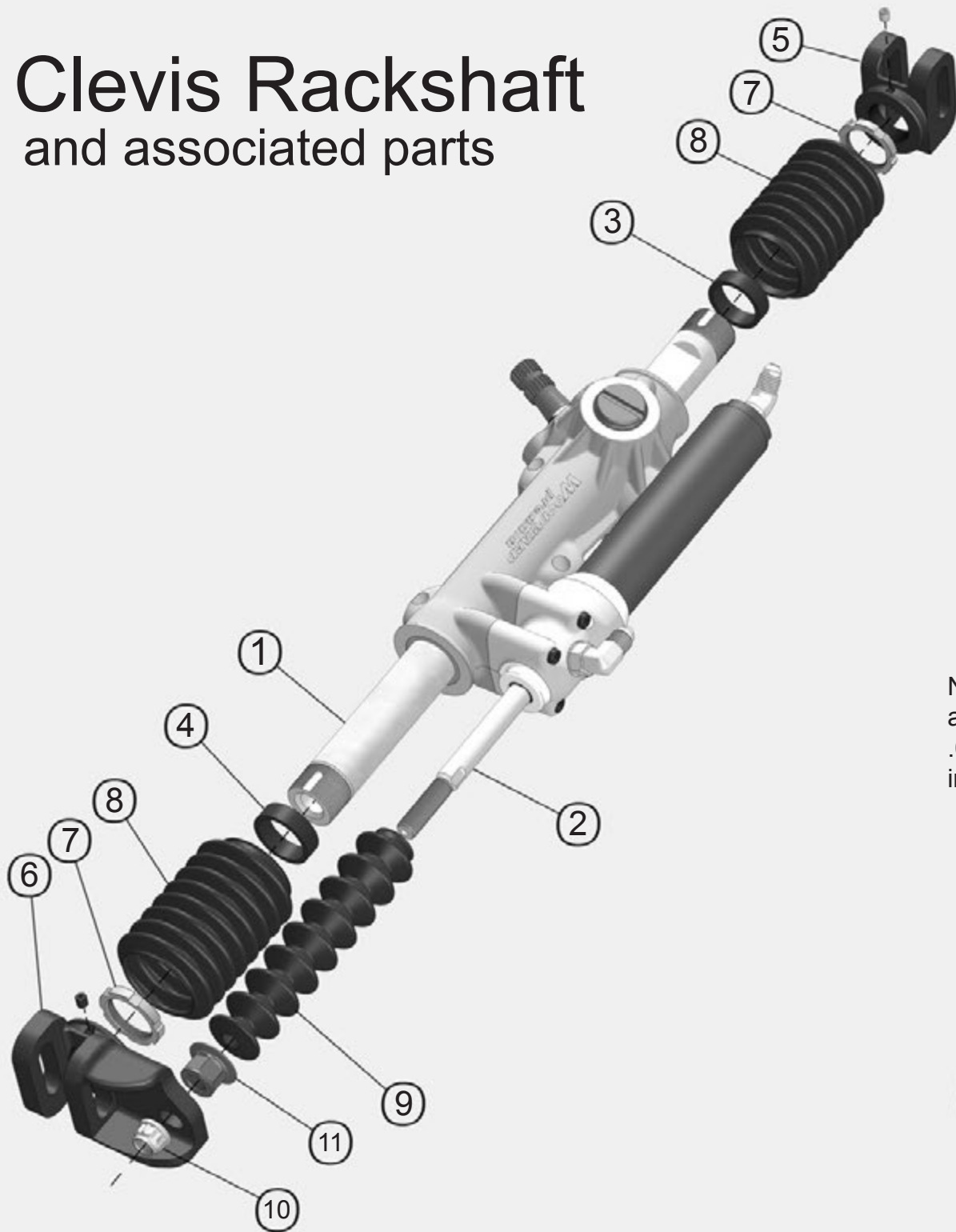

(Drawn without boots
to show assembled parts)

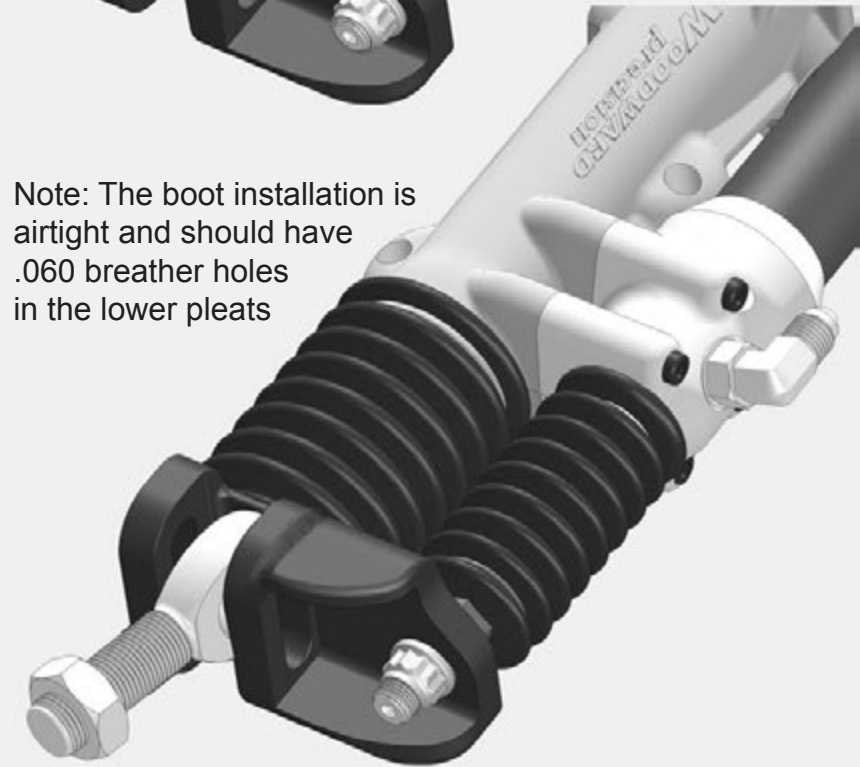

Note: The boot installation is
airtight and should have
.060 breather holes
in the lower pleats

Parts used with Clevis Rackshaft (rack types GEC, GLC, HEC and HLC)

Dwg no.	Part no.	Description
1	GEC230-8-1825	Clevis rackshaft for 2.09 ratio only, 18.25 centers
	GEC230-9-1825	Clevis rackshaft for 2.36 ratio only, 18.25 centers
	GEC230-10-1825	Clevis rackshaft for all ratios 2.62 thru 4.45, 18.25 centers
	GEC230-10-1925	Clevis rackshaft for all ratios 2.62 thru 4.45, 19.25 centers
	GEC230-10-1975	Clevis rackshaft for all ratios 2.62 thru 4.45, 19.75 centers
2	GEC170C-1825	Piston rod for clevis racks with 18.25 centers
	GEC170C-1925	Piston rod for clevis racks with 19.25 centers
	GEC170C-1975	Piston rod for clevis racks with 19.75 centers
3	GEC202	Travel stop, used on right and left sides of 18.25 and 19.25 rackshafts
4	GEC203	Travel stop, used on right side only of 19.75 rackshafts
5	GEC410	Clevis, plain (<i>includes 1/4-28 x 5/16 set screw</i>)
6	GEC410B	Clevis, with rod bracket (<i>includes 1/4-28 x 5/16 set screw</i>)
7	GEC411	Spanner type jam nut (2)
8	GEC360	Rack boot (2)
9	GEC361	Rod boot
10	GEC176	Rod lock nut, NAS1804-8
11	GEC177	Rod nut and boot retainer

GE150B and GE150C Cylinder

Exploded View

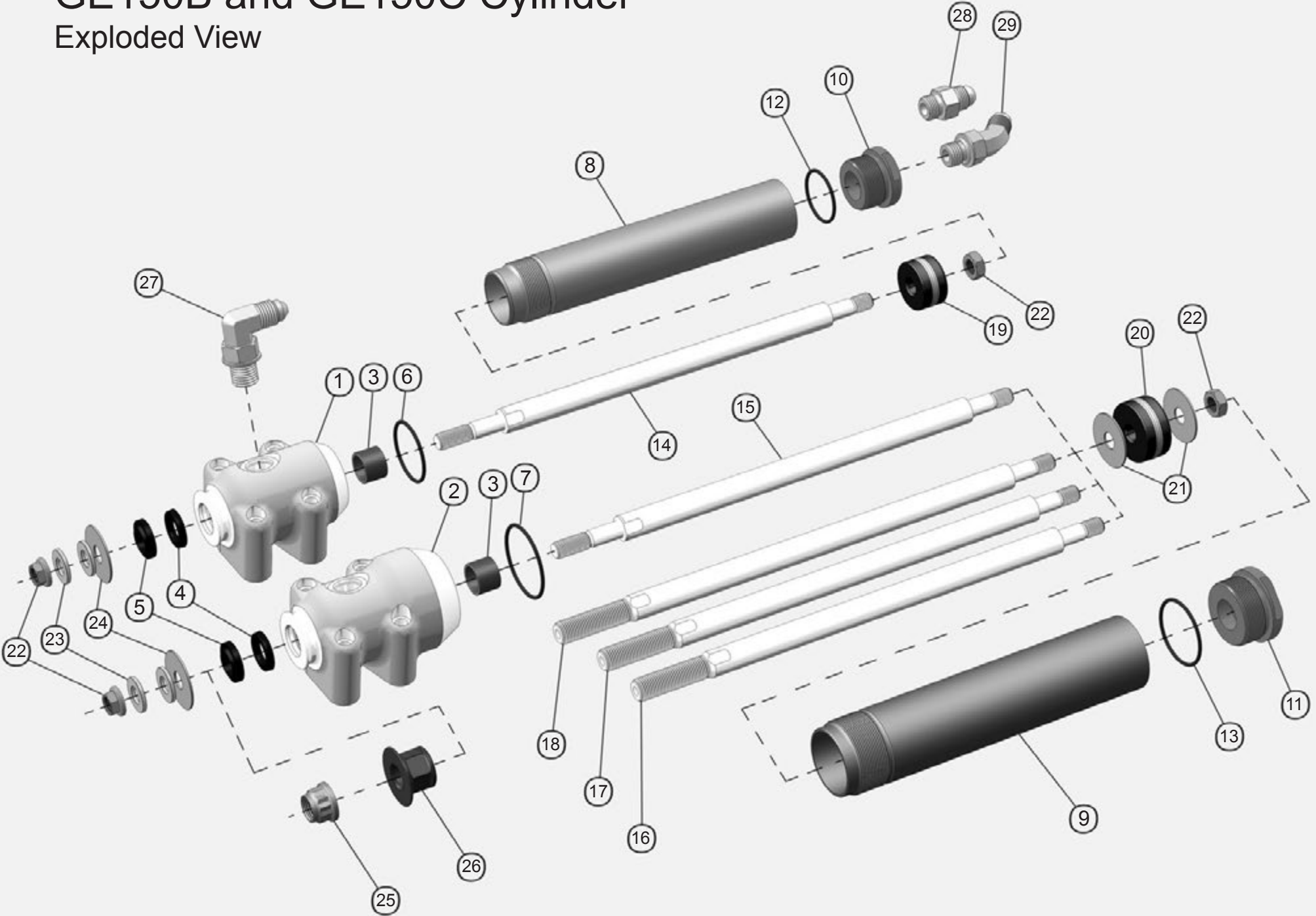

GE150B and GE150C Cylinder Parts List (see also Installation Hardware)

Applications of cylinders:

GE150B is backward-compatible to 1989 and is the replacement cylinder for older type G and H racks using the G264 rod bracket. It will also fit all current GE, HE, GL and HL models except for clevis racks.

GE150C is a larger-bore cylinder intended for higher loads. It will bolt directly to 4.19 and 4.45 GH/HE rack housings using the GE264 rod bracket. Mounting on all other GE/HE ratios requires the GE151S shim, the longer GE265 rod bracket, and a low head bolt for clearance. No shim is needed on GL and HL racks. *Please note, a C cylinder cannot be installed on old type G or H housings.*

GEC150C is made in three lengths to fit clevis racks. The lengths are non-interchangeable. The piston rods have a larger threaded diameter with a special nut that seats on a taper on the rod and shoulders against the rod bracket. Housings other than 4.19 and 4.45 use the GE151S shim.

Dwg no.	Part no.	Description	Dwg no.	Part no.	Description
1	GE151B	Head casting for 1.13 bore cylinder	16	GEC170C-1875	Piston rod for C cylinder used on clevis racks 18.75 long
2	GE151C	Head casting for 1.38 bore cylinder	17	GEC170C-1925	Piston rod for C cylinder used on clevis racks 19.25 long
3	GE152	Rod bushing 9/16 x 11/16OD x 1/2L	18	GEC170C-1975	Piston rod for C cylinder used on clevis racks 19.75 long
4	GE153	Loaded lip seal	19	GE171B	Piston/seal assembly for 1.13 bore
5	GE154	Rod wiper	20	GE171C	Piston/seal assembly for 1.38 bore
6	GE155B	Tube O-ring for 1.13 bore	21	GE172C	Backup washers for C piston
7	GE155C	Tube O-ring for 1.38 bore	22	GE173	3/8-24 lock nut
-	GE156	1/4-20 x 2 socket head cap screw (4)	23	GE174	3/8 SAE hardened flat washer (2)
8	GE160B	Cylinder tube, 1.13 bore	24	GE175	3/8 x 1-1/4 fender washer (boot retainer)
9	GE160C	Cylinder tube, 1.38 bore	25	GE176	1/2-20 12-pt. lock nut for GEC170 rods
10	GE161B	Cylinder plug, 1.13 bore	26	GE177	1/2-20 taper seat nut/boot retainer for GEC170 rods
11	GE161C	Cylinder plug, 1.38 bore	27	PS190	Hose adapter, steel, -6 male O-ring to -6 AN male flare, orientable 90 degree elbow
12	GE162B	Plug O-ring, 1.13 bore	28	PS180	Hose adapter, steel, -6 male O-ring to -6 AN male flare, straight
13	GE162C	Plug O-ring, 1.38 bore			
14	GE170B	Piston rod for B cylinder used on standard tie-rod and monoball racks	29	PS145	Hose adapter, steel, -6 male O-ring to -6 AN male flare, orientable 45 degree elbow
15	GE170C	Piston rod for C cylinder used on standard tie-rod and monoball racks			

Installation Hardware used with GE150B and GE150C Cylinders

2.09, 2.36, 2.62, 2.88,
3.14, 3.40, 3.66 and
3.92 GE/HE housings

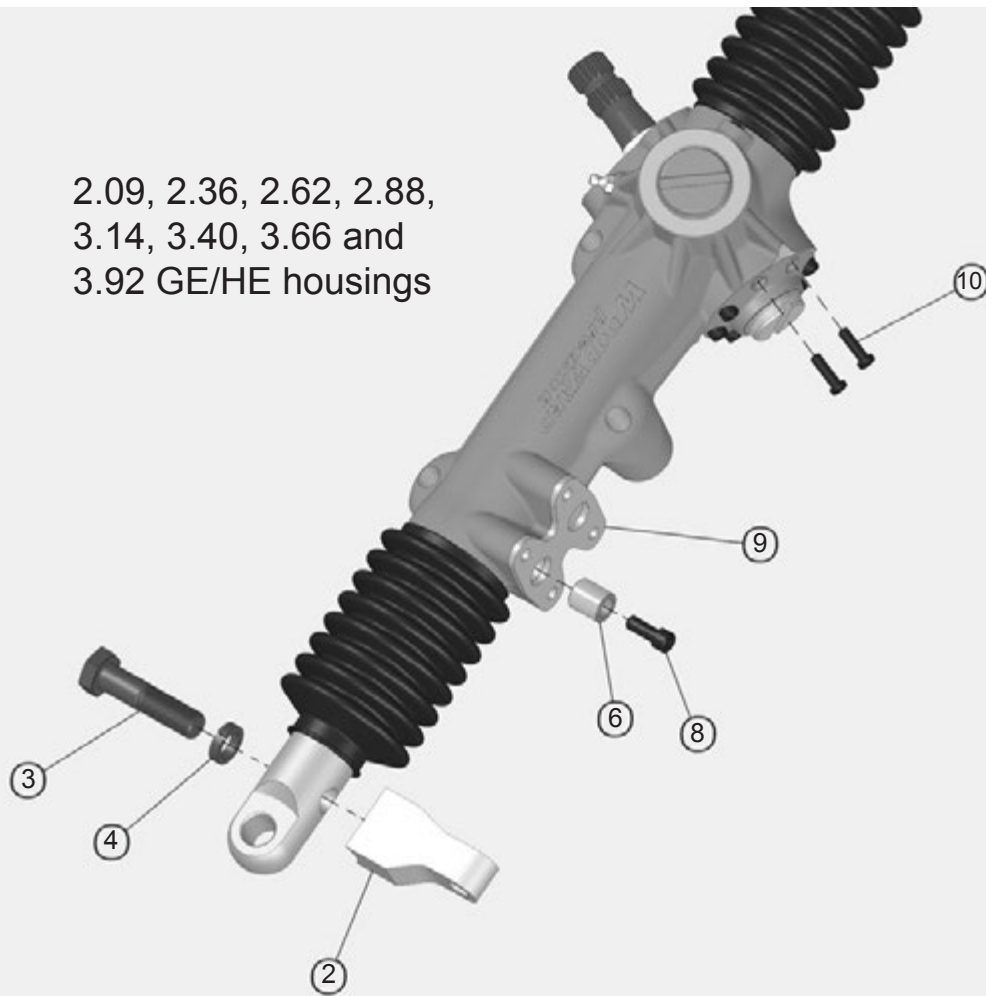

4.19 and 4.45
GE/HE housings and
all GL/HL housings

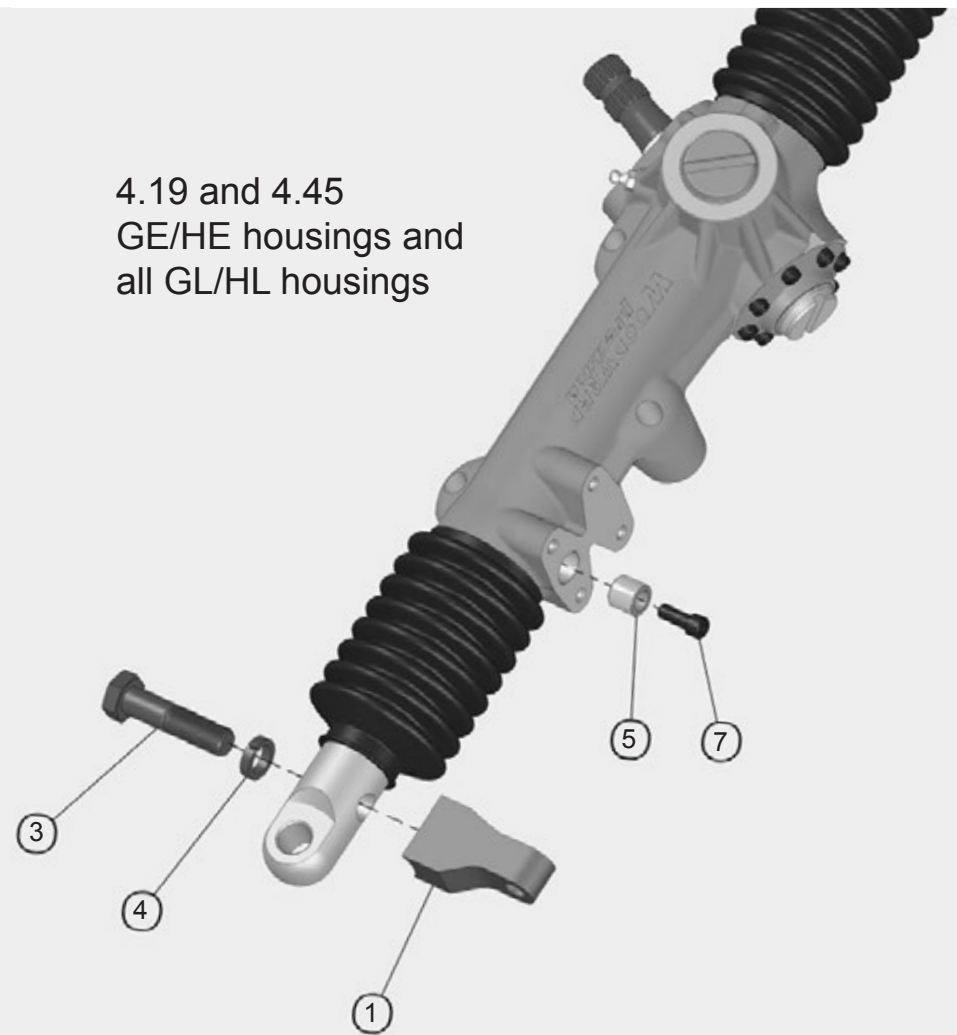

Parts List

Dwg no.	Part no.	Description
1	GE264	Rod Bracket (includes cap screw and lock washer)
2	GE265	Rod Bracket (includes cap screw and lock washer)
3	-	1/2-20 x 2 Grade 8 hex cap screw
4	-	1/2 high-collar split-ring lock washer
5	GE107	Dowel, 9/16 x 1/2L (includes cap screw)

Dwg no.	Part no.	Description
6	GE108	Dowel, 9/16 x 5/8L (includes cap screw)
7	-	1/4-20 x 1/2 socket head cap screw
8	-	1/4-20 x 5/8 socket head cap screw
9	GE151S	Shim
10	-	#10-24 x 5/8 low head socket cap screw

Part no. -201

Title PINION SPLINE

PROPRIETARY AND CONFIDENTIAL: This drawing is the sole property of Woodward Machine Corporation and may only be copied or used in such a manner and with such purpose as authorized in writing by Woodward Machine Corporation. Possession of this document does not by itself confer such authorization. The information contained herein is confidential and dissemination or disclosure of such information to a third party is prohibited.

Date	Rev.

"201" spline
(3/4 x 20T non-involute form)

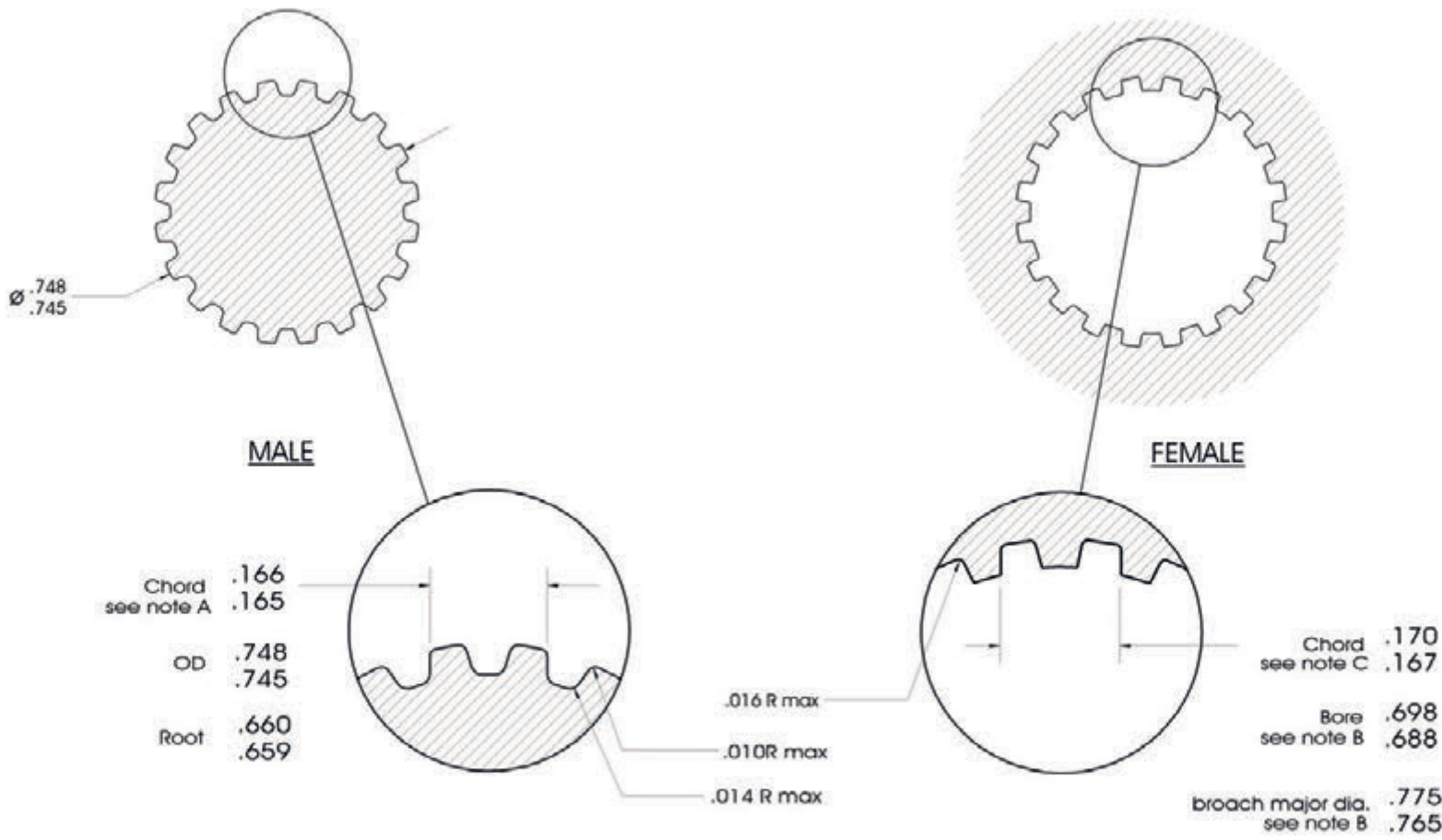

Date
Approved for production

- NOTES:
- A. Opposite sides of adjacent teeth are PARALLEL
 - B. Closed sliding joints must have an air gap
 - C. Use minimum material condition for parts that will be plated

Part no. -201 Rev.

Woodward Machine Corporation

PINION SPLINE

Start and finish: _____ Used on: _____

Heat treatment: _____ Drawn by: ALW Date: 6-97

Tolerances +/-
.XXX"
.XX"
Fractions"
Angles"
Unless otherwise specified,
all dimensions are in inches.
DO NOT SCALE DRAWING

Part No. UA20201 and ST201A

Title SPLINE CONNECTION, TYPICAL

PROPRIETARY AND CONFIDENTIAL: This drawing is the sole property of Woodward Machine Corporation and may only be copied or used in such a manner and with such purpose as authorized in writing by Woodward Machine Corporation. Possession of this document does not by itself confer such authorization. The information contained herein is confidential and dissemination or disclosure of such information to a third party is prohibited.

Date	Rev.

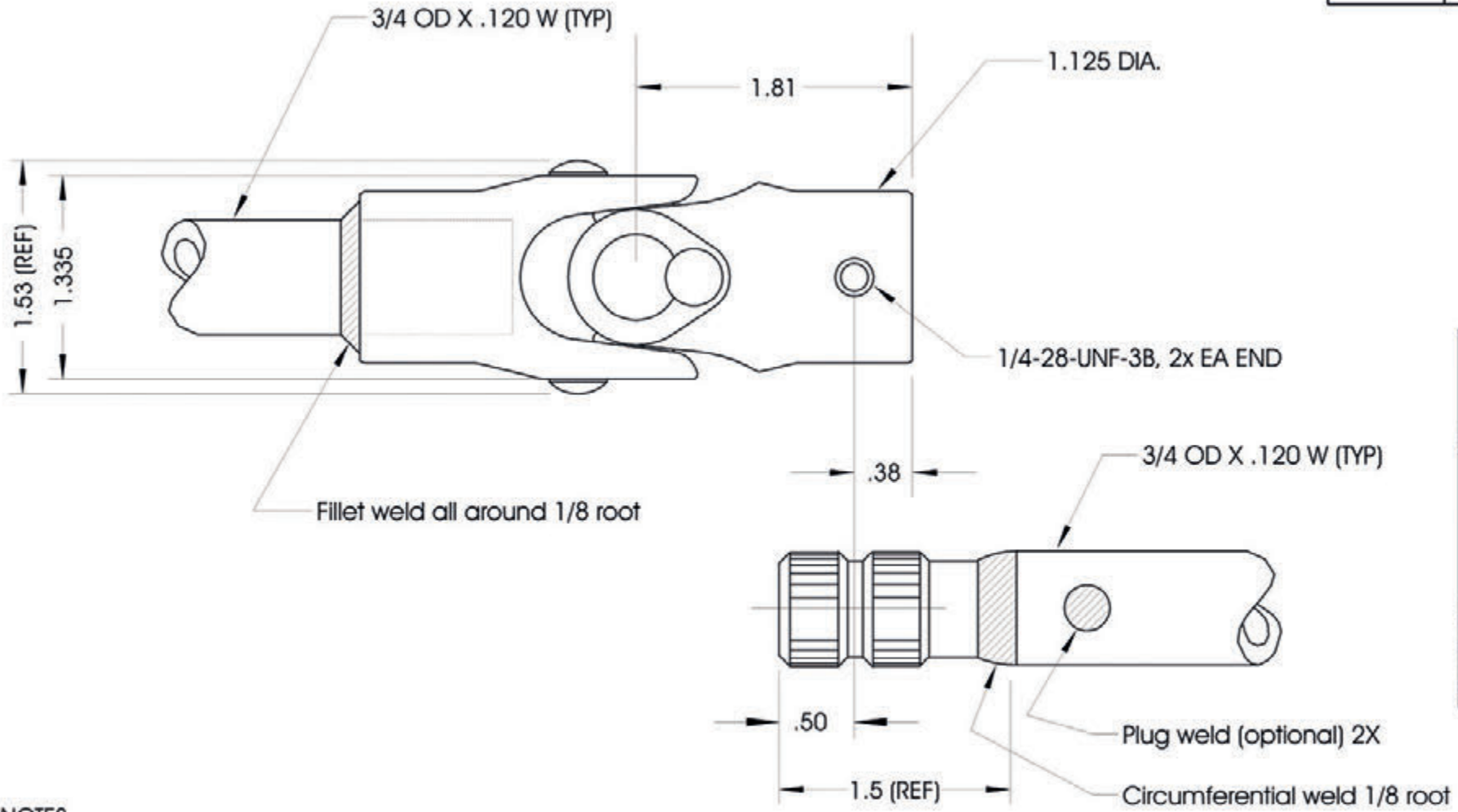

NOTES

1. Recommended welding procedure: ER80S-D2 or ER90S-D2 with 75%Ar/25%CO2
2. U-joints to be fillet welded on end surfaces only; DO NOT ADD PLUG OR ROSETTE WELDS TO U-JOINTS

Approved for production

Part No. UA20201 and ST201A Rev.

Woodward Machine Corporation

SPLINE CONNECTION, TYPICAL

Tolerances +/-
.XXX=
.XX=
Fractions=
Angles=
Unless otherwise specified, all dimensions are in inches. DO NOT SCALE DRAWING

Material and finish	Drawn on
Heat treatment	Fabricated steering shafts
Drawn by	Scale
ALW	6 May 12

Part no. C101 thru C201

Title Weld-on spline coupler

PROPRIETARY AND CONFIDENTIAL: This drawing is the sole property of Woodward Machine Corporation and may only be copied or used in such a manner and with such purpose as authorized in writing by Woodward Machine Corporation. Possession of this document does not by itself confer such authorization. The information contained herein is confidential and dissemination or disclosure of such information to a third party is prohibited.

Date	Rev.

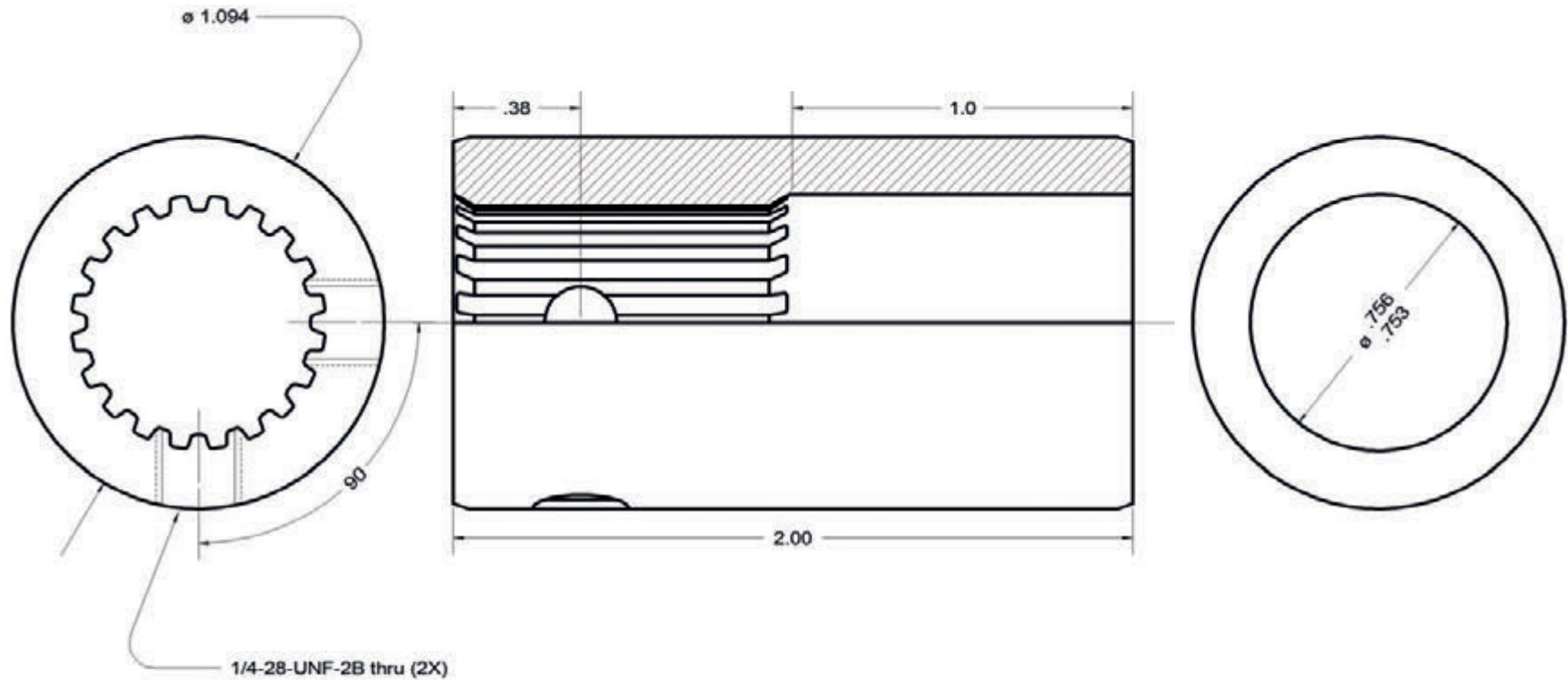

Date
Approved for production

Part no. C101 thru C201

Woodward Machine Corporation

Weld-on spline coupler

Tolerances +/-
 .XXX=
 .XX=
 Fractions=
 Angles=
 Unless otherwise specified,
 all dimensions are in inches.
 DO NOT SCALE DRAWING

Material 1-1/8 rd. 12L14 steel

Weld on

Heat treatment

Drawn by ALW

Date 15 May 13

Part no.

QRA/QRS

Title

Quick release hub

PROPRIETARY AND CONFIDENTIAL: This drawing is the sole property of Woodward Machine Corporation and may only be copied or used in such a manner and with such purpose as authorized in writing by Woodward Machine Corporation. Possession of this document does not by itself confer such authorization. The information contained herein is confidential and dissemination or disclosure of such information to a third party is prohibited.

Date

Rev.

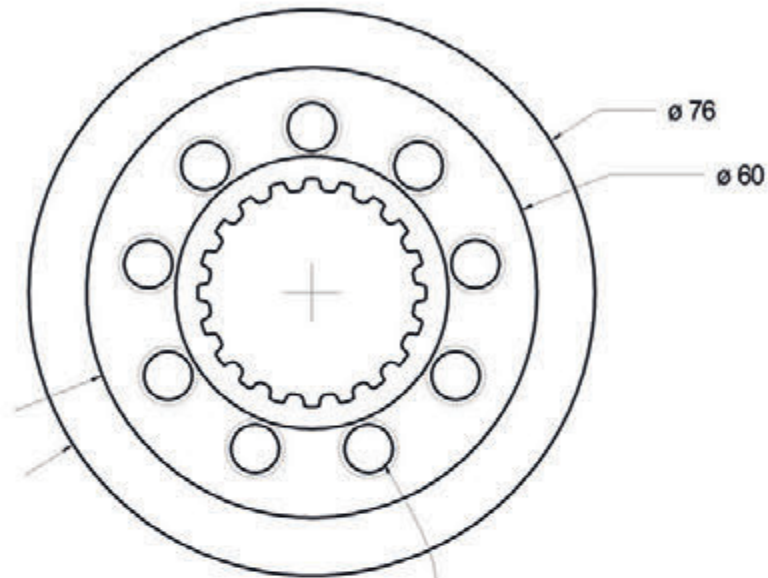
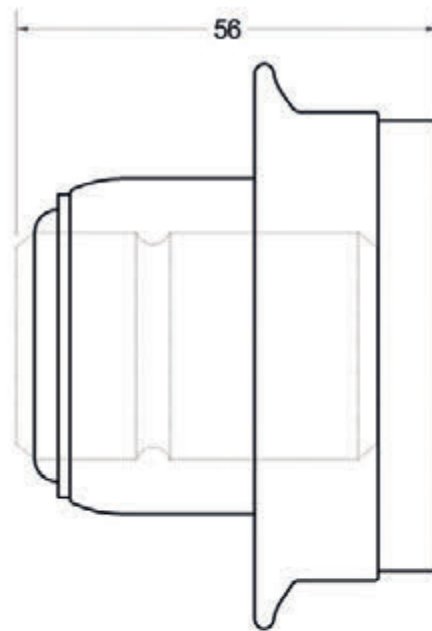

Bolt-on style fits SCA700 post

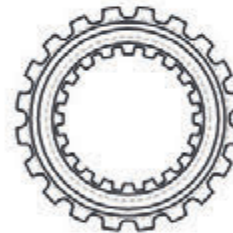
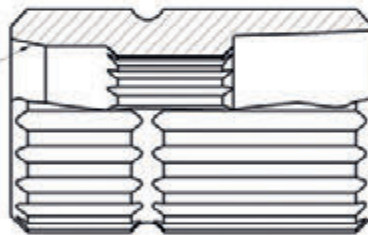

5/16-18 UNC
9 pl. eq. sp. on
1.75 dia. bolt circle

Weld-on style fits 3/4 tubing (ref)

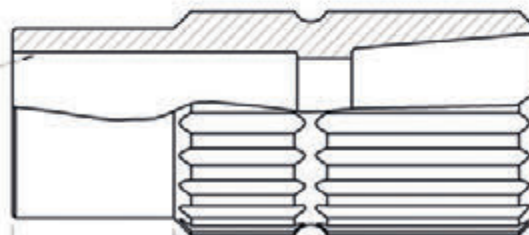

Date
Approval for production

Part no. QRA/QRS Rev.

Woodward Machine Corporation

Quick release hub reference dimensions

Tolerances +/-
 .XXX=
 .XX=
 Fractions=
 Angles=
 Unless otherwise specified,
 all dimensions are in inches.
 DO NOT SCALE DRAWING

Design and finish	Used on
Heat treatment	Drawn by
	Date

part no. MB177/178/179

title Dash bar mounting

PROPRIETARY AND CONFIDENTIAL: This drawing is the sole property of Woodward Machine Corporation and may only be copied or used in such a manner and with such purpose as authorized in writing by Woodward Machine Corporation. Possession of this document does not by itself confer such authorization. The information contained herein is confidential and dissemination or disclosure of such information to a third party is prohibited.

date	rev.

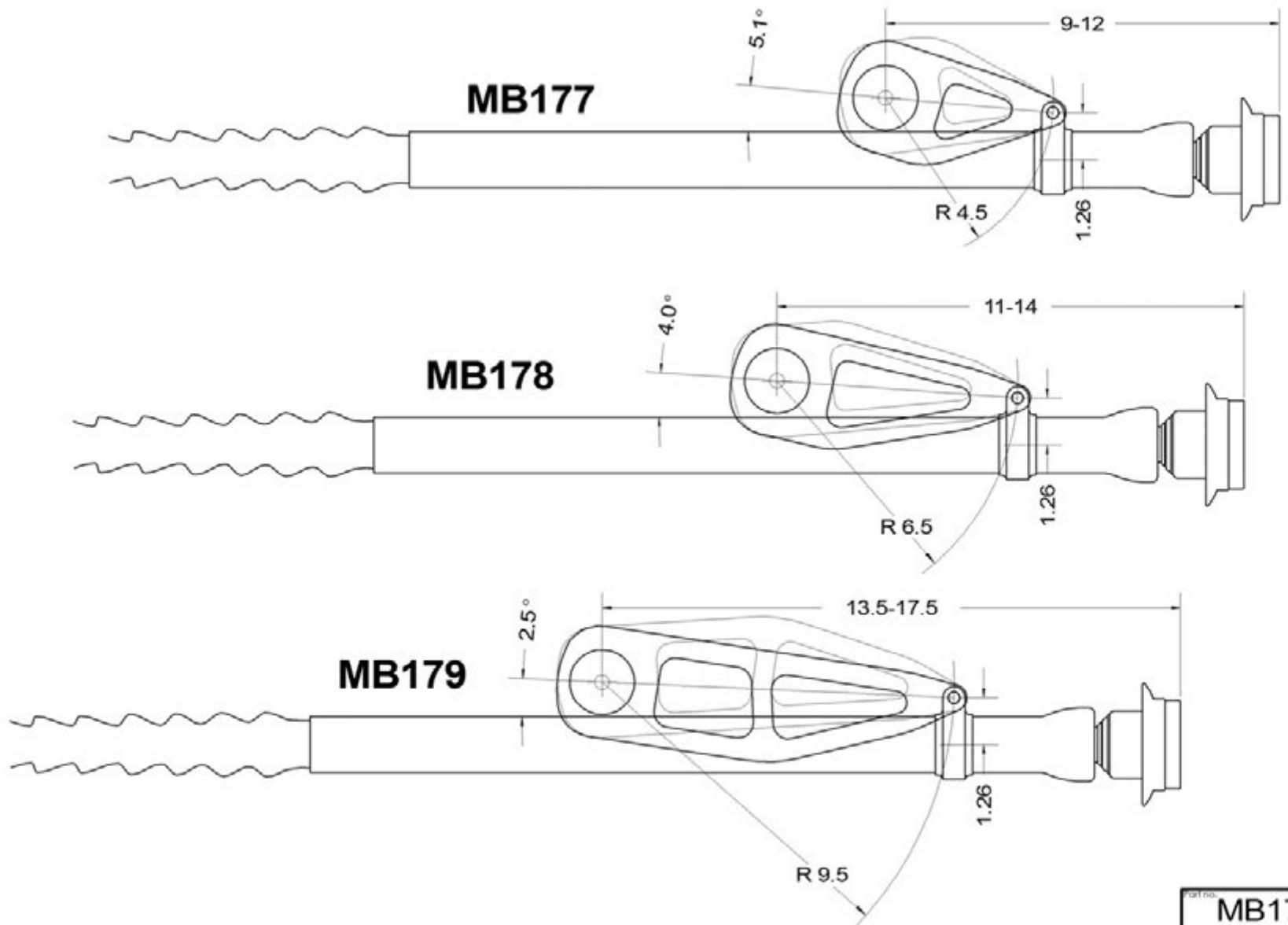

Date
Approved for production

part no. MB177/178/179 rev.

Woodward Machine Corporation
3592 Burd Road PO Box 4479 Casper WY 82604 USA 1-307-472-0550

title Dash Bar Mounting Bracket Applications

dash and trim	used on SCA700
heat treatment	drawn by ALW date 24 Mar 15

Tolerances +/-
.XXX"
.XX"
Fractions"
Angles"
Unless otherwise specified,
all dimensions are in inches.
DO NOT SCALE DRAWING

Part no.

SBC6-2

FIREWALL MINI-BUSHING

PROPRIETARY AND CONFIDENTIAL: This drawing is the sole property of Woodward Machine Corporation and may only be copied or used in such a manner and with such purpose as authorized in writing by Woodward Machine Corporation. Possession of this document does not by itself confer such authorization. The information contained herein is confidential and dissemination or disclosure of such information to a third party is prohibited.

Date	Rev.

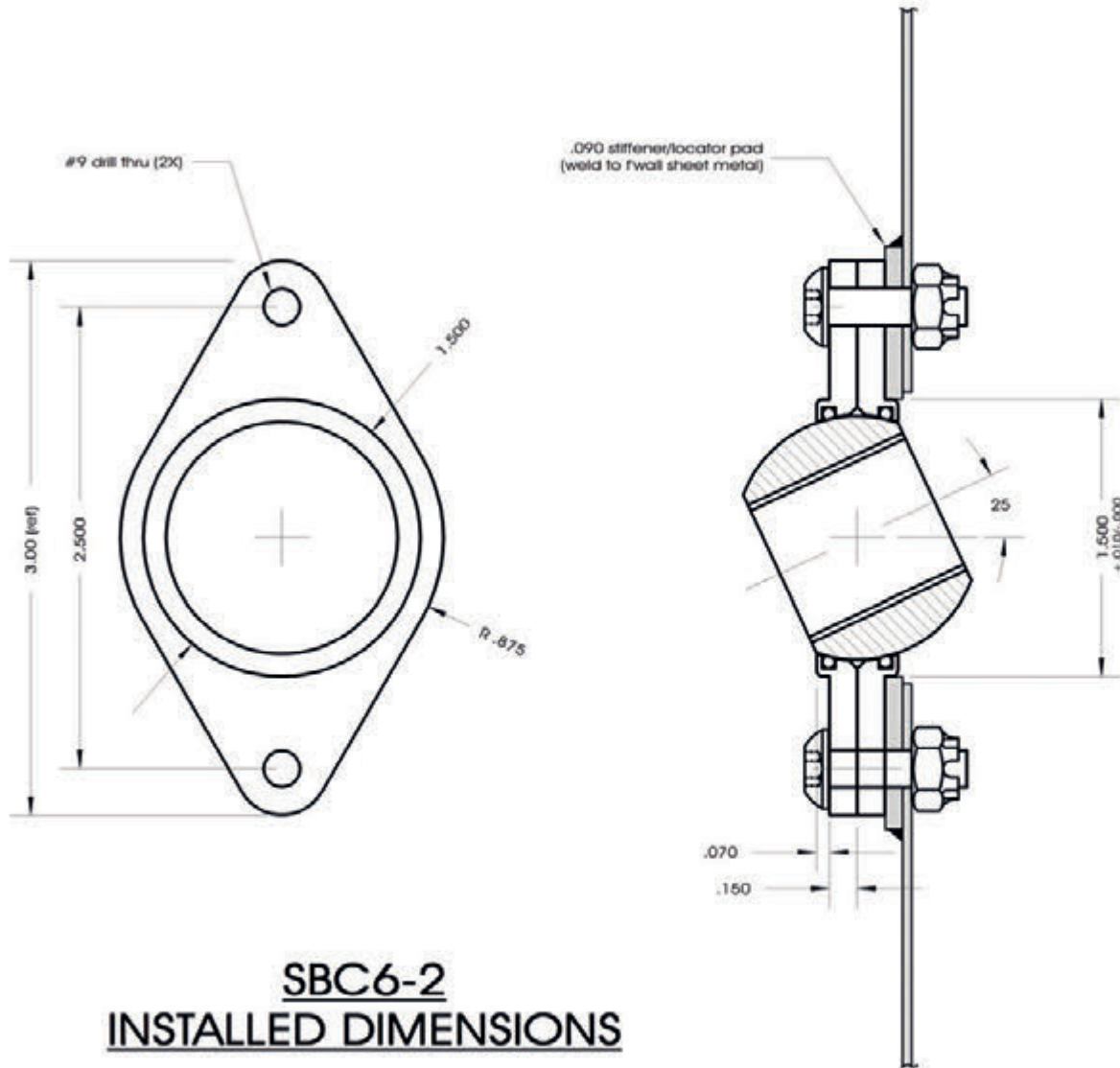

SBC6-2
INSTALLED DIMENSIONS

Date
Approved for production

Part no.	SBC6-2	Rev.	
----------	---------------	------	--

Woodward Machine Corporation

FIREWALL MINI-BUSHING

Tolerances +/-
 .XXX=
 .XX=
 Fractions=
 Angles=
 Unless otherwise specified,
 all dimensions are in inches.
DO NOT SCALE DRAWING

Material and finish	Used on
Heat treatment	Drawn by
	Date
	22 Sept 06

Woodward
Type MR and MRC
Power Steering Rack



Cylinder seal replacement
Cylinder/rackshaft reassembly
Testing

1



Protect the rack teeth and hold the rackshaft in a bench vise. Ease the inner end of the cylinder onto the rackshaft. Use lubricant to protect the rubber seal. Using blue Loctite 242 (or equivalent) on the threads, screw the stud partway into the rackshaft.

2



Install the piston and apply Loctite to the exposed end of the stud. Avoid spreading Loctite into the contact surfaces of rackshaft and piston. With a large adjustable wrench, tighten the joint to 60 lb/ft or 80 NM.

3

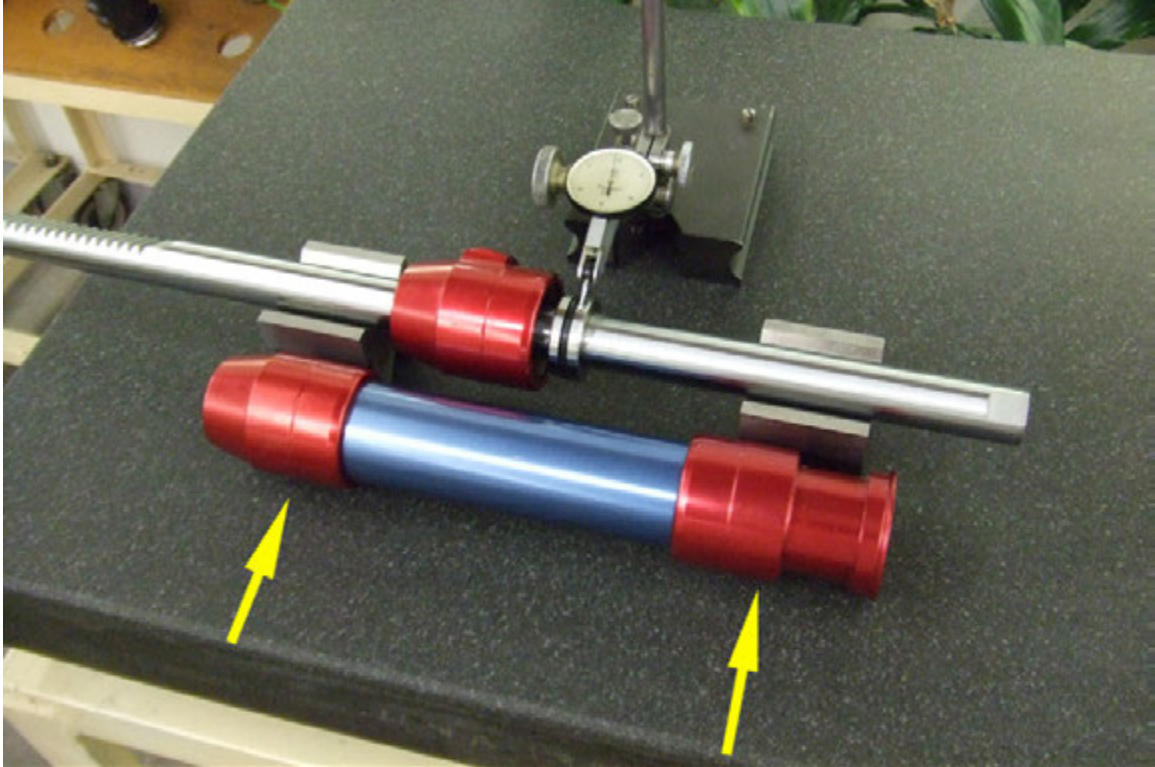

Test for straightness by supporting the assembled rackshaft in V-blocks on a surface plate. SPACE THE V-BLOCKS THE SAME DISTANCE APART AS THE BEARINGS IN THE CYLINDER. The piston must run true within .0025 inch/.064 mm. If it runs out, immediately break the joint loose and rotate the piston to reseal it, then retighten the joint and retest.

4



Coat the inside of the tube and all o-rings with petroleum jelly. Slip the tube over the piston. Apply anti-seize lubricant to the threads and screw both ends onto the tube. Install -6 fittings in the ports. Tighten the ends using rods inserted in the fittings. Be sure the tube will seat positively into the ends.

5



Hold the cylinder and move the rackshaft full travel by hand. Even with new seals it should be movable. With a rubber-tipped blowgun, apply shop air pressure (120-175psi / 8-12 bar) to each end alternately. The rackshaft should respond instantly without sticking. Any leakage will be audible. As a general rule, if the assembly can be operated with air, it will operate with hydraulic fluid.

6



The cylinder and rackshaft can now be joined to the rack housing. Apply blue Loctite (or equivalent) and seat the housing tube all the way into the cylinder end. To adjust the position of the ports, loosen the jam nut and rotate the tube in the housing. This will also adjust the cylinder closer to or farther away from the housing by .050 inch / 1.27 mm per turn.

Housing length adjustment

7

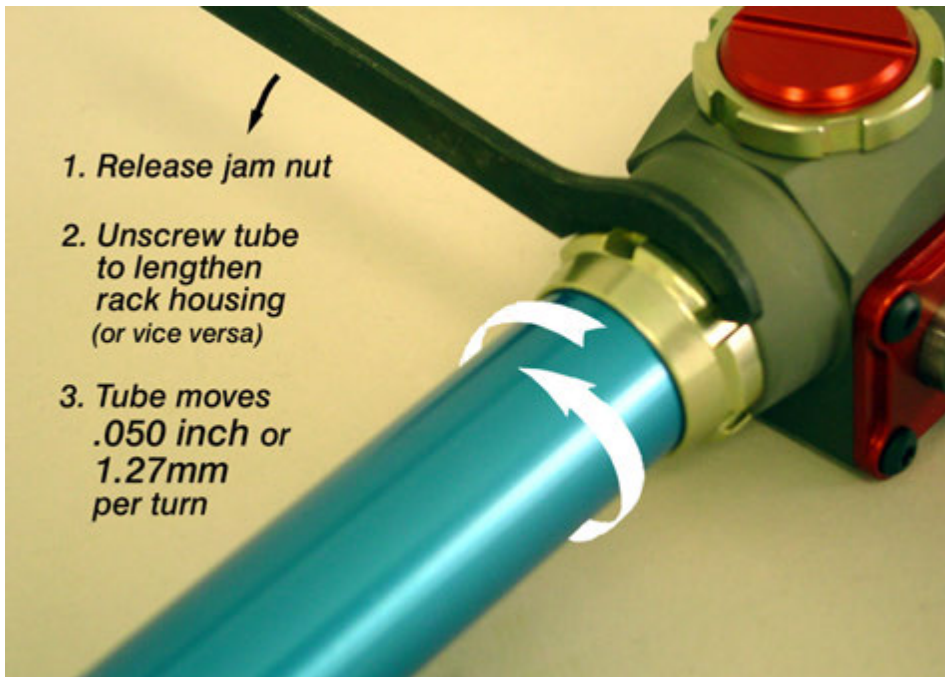

Functional testing procedure and equipment

8



Testing for pressure and leakdown can be done with a gauge and flow meter. Install the gauge in the pressure line and the flow meter in the return line. The rack must be equipped with TRAVEL STOPS to prevent the pinion from reaching the end of the rack teeth under power. Using a tool to simulate a steering wheel, turn the steering to full lock. Apply varying torque and observe the gauge; the pressure should rise instantaneously and in direct proportion to the torque. At a certain point the pump will go into relief and the pressure will rise no higher. At this point the flow should instantaneously drop below 0.05 gpm / .2 lpm. Although it may not be noticeable in a race car, a higher value indicates leakage in the servo or cylinder and the unit should be serviced at the next opportunity.

9



Rack at full left lock. The pump has reached its relief point, in this case a pressure of approximately 1500 psi / 103 bar. The flow is zero, indicating that all the seals function perfectly when steering to the right.

10



The same rack at full right lock. The pump hits relief at a point within 1% of left lock, which is well within normal variation, and the leakdown is zero.

An inconsistent relief point can indicate pump wear or debris in the system.

Servo exploded view

applies to servos coupled inline and servos mounted to HE and HL racks

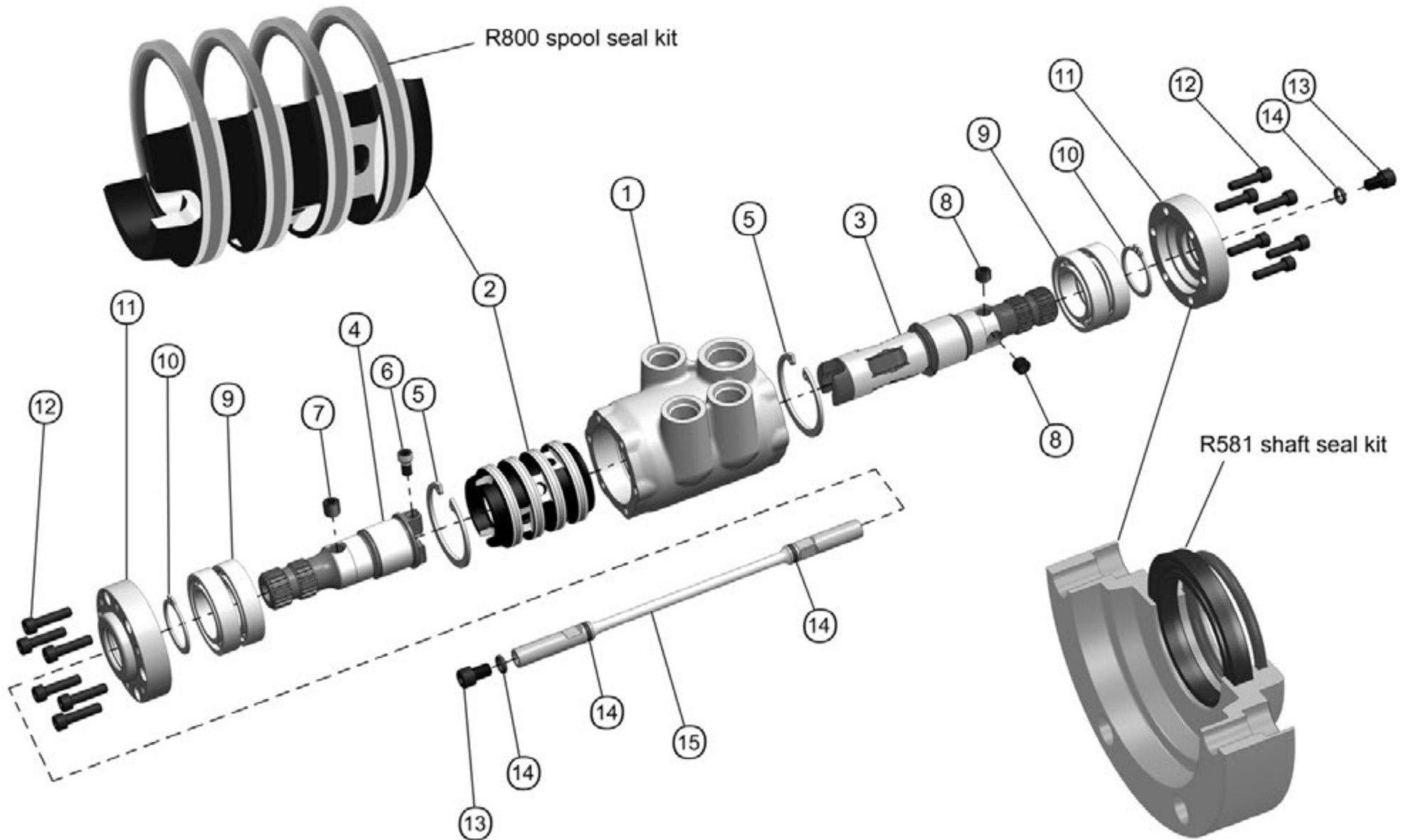

Servo parts list

(applies to servos coupled inline and servos mounted to HE and HL racks)

Dwg no.	Part no.	Description	Dwg no.	Part no.	Description
1	V600 V700 (<i>shown</i>)	Housing	13	TB353	Torsion bar plug screw, 1/4-28 x 3/8 (2)
2	V601 V601C	Valve spool	14	TB000	Torsion bar O-ring
3	V570-50-1 V570-50-2 V570-50-2C V570-55	Valve input shaft	15	TB180 TB185 TB190 TB195 TB200 TB205 TB210 TB215 TB220 TB225 TB230 TB235 TB240	Torsion bar
<i>(Note: the spool and input shaft together comprise a Valve Assembly and are sold as a unit)</i>					
4	V571	Output shaft			
5	V641	Housing snap ring (2)			
6	V572	Spool drive bolt			
7	V575A	Anchor screw, 5/16-24 x 5/16 w/ machined end			
8	V575B	Centering adjustment screw, 5/16-24 x 1/4 cup point (2)			
9	V640	Ball bearing (4)			
10	V574	Shaft snap ring (2)			
11	V580	End cap (2)			
12	V350	Socket head cap screw, #10-24 x 3/4 (12)			

Servo Installation, type HE and HL racks

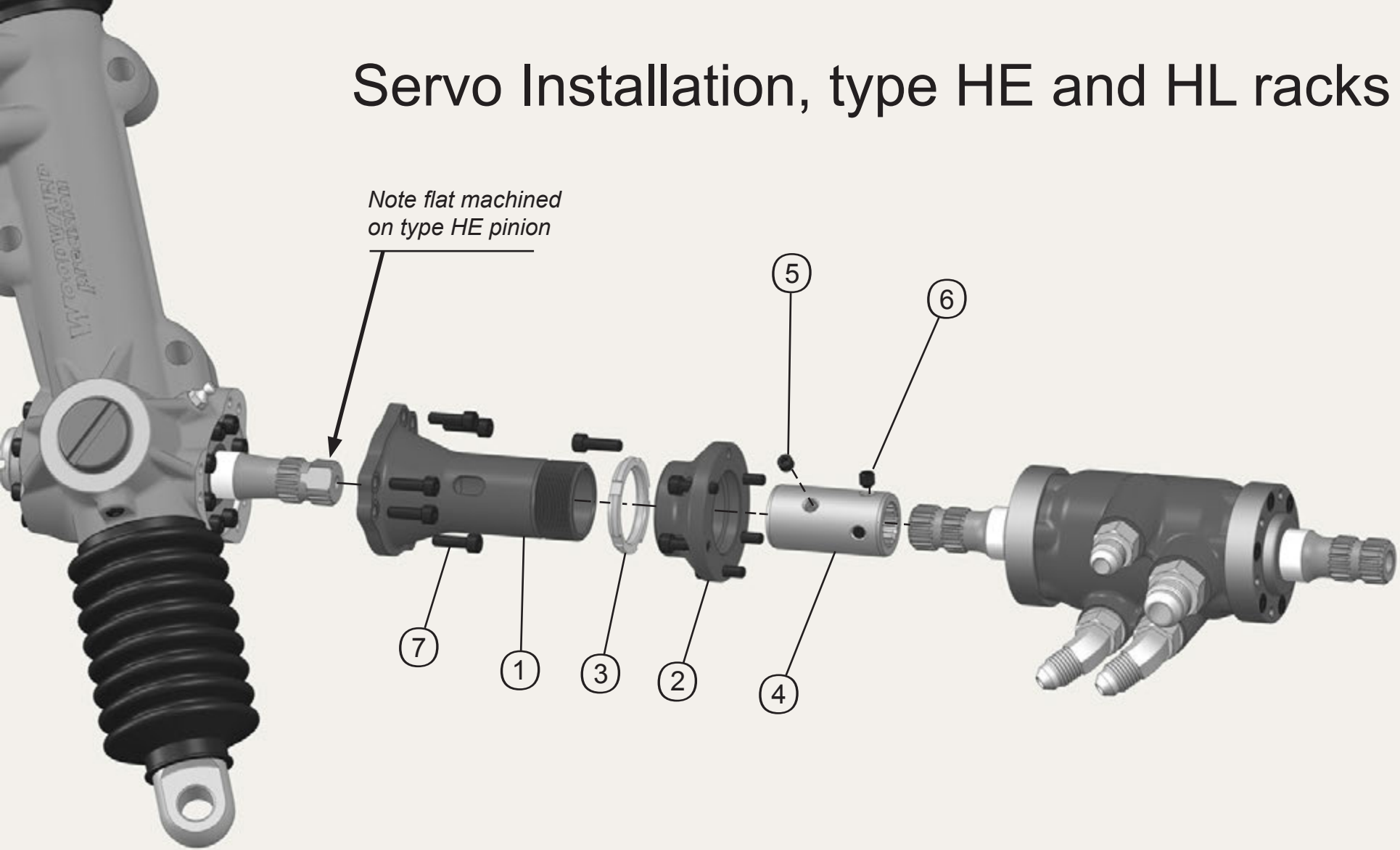

Parts List

Dwg no.	Part no.	Description	Dwg no.	Part no.	Description
1	GE584	Servo adapter flange	5	VHE201A	1/4-28 x 3/16 knurled cup point set screw
2	GE585	Servo adapter cap	6	VHE201B	1/4-28 x 1/4 knurled cup point set screw (2)
3	GE586	1-5/16-24 spanner type jam nut	7	GE351	#10-24 x 5/8 socket head cap screw (12)
4	VHE201	Splined coupler			

Assembly Sequence

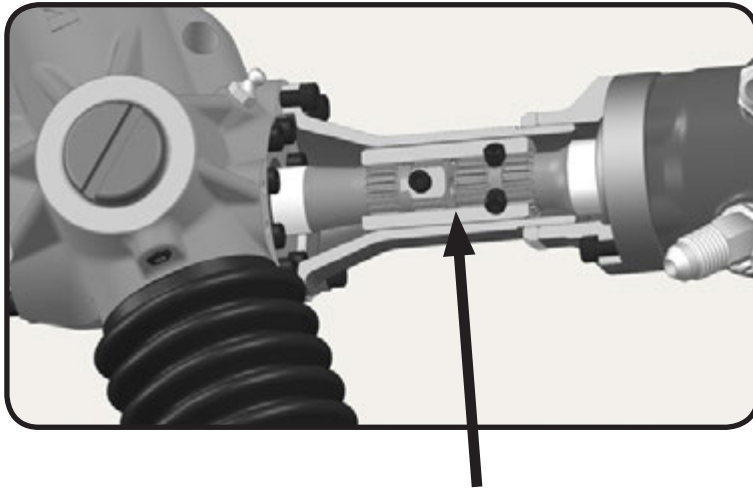

Minimum .005 (0,13) gap

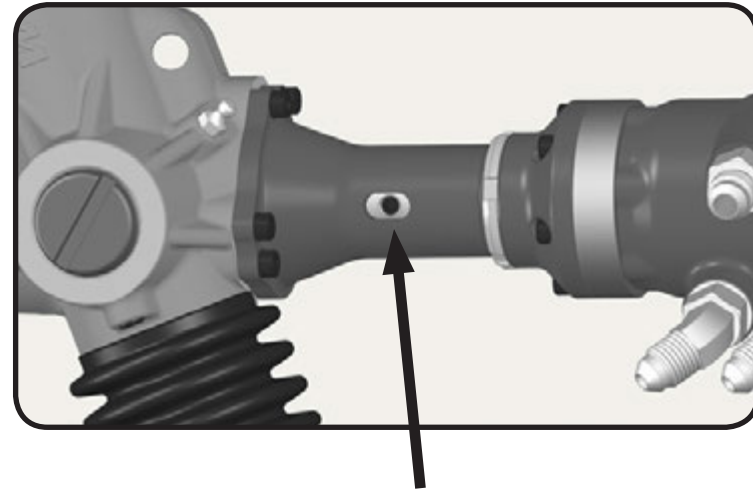

Set screw visible in slot

1. Assemble parts 1, 2, and 3 together using anti-seize compound on the threads. Temporarily bolt the flange to the rack housing and the cap to the servo. Screw the adapter together until the servo shaft touches the pinion, then adjust it out until the two parts are separated by .005 and the hose fittings on the servo are aimed approximately where you want them. Snug the jam nut to hold the parts in place.

2. Unbolt the adapter assembly from the rack and servo. Coat the splined shafts with anti-seize or grease. Secure the splined coupler onto the servo shaft with the two set screws VHE201B. Install the short set screw VHE201A so it is just flush with the surface of the coupler. Make sure it clears the inside of the adapter.

3. Bolt the assembly to the servo so that the short set screw is visible in the access slot. Align the set screw with the flat on the pinion.

4. Slide the servo and adapter onto the pinion and bolt the flange to the rack housing.

5. Rotate the servo to its final position (or connect its hoses and let them dictate the final position). Tighten the jam nut.

6. Carefully remove the short set screw and apply threadlocking adhesive (blue Loctite® #242 or #243, or equivalent). Reinstall the set screw, but not fully tight.

7. Loosen the 6 screws holding the assembly to the rack housing and retighten them.

8. Last, tighten the set screw. Wipe off any excess threadlocker and wrap electrical tape over the access slot to keep water out of the splined connection.

Woodward Machine Corporation
www.woodwardsteering.com

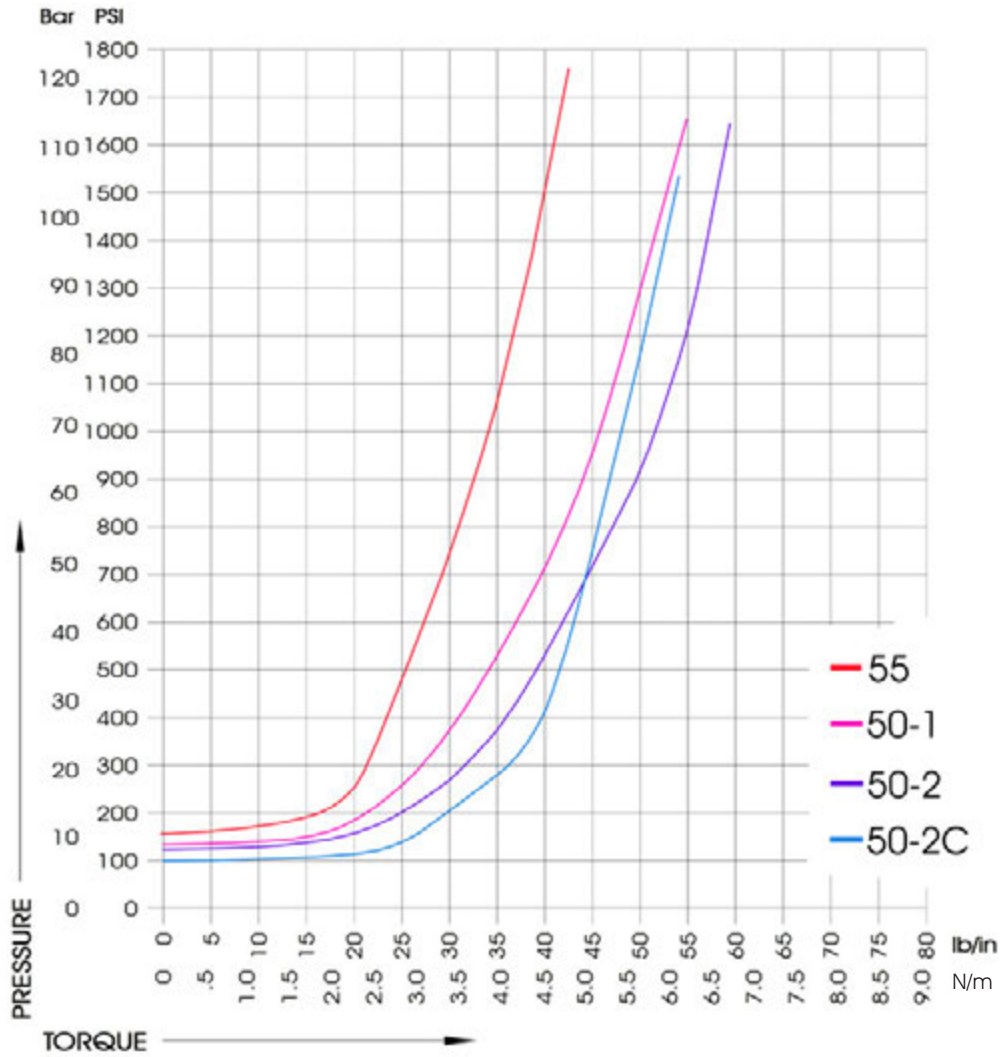

Servo VA900 series
Reference T-bar 210

*Change in pump volume displaces curve vertically
Change in torsion bar displaces curve horizontally*

Since the last edition of the catalog, we have expanded the number of rack types we manufacture, and the breadth of options now includes one-off specials. A replacement rack for an existing race car is still simple to order from this catalog—if you know nothing else about it, just read us the serial number. We keep records going back 20 years and can determine its type, length, ratio, when it was built, and to whom it was sold. In some cases, however, specifying a rack can become a daunting exercise, especially if you are building a chassis from scratch. In order to demystify the subject as far as possible, we have taken the most frequent questions asked about rack and pinion steering in race cars and addressed them in the following pages, beginning with the most basic mechanical elements and progressing through a treatise on hydraulic power steering.

Configuring a rack for your race car

1. Rack length:

All automobiles, regardless of type, require that the steering be caused by driver input rather than by suspension movement. If the vertical travel of the front wheels also steers them, the car may be impossible to drive at speed. This is the serious defect known as bump steer. Bump steer will result from bolting in a rack and pinion of a length incompatible with the rest of the suspension, which is a very common mistake on street rods, and not exactly unknown on race cars. Oval track chassis builders generally minimize bump steer by locating the rack pivot centers (the inner tie rod ends) directly in front of the lower control arm pivots. If you are building a chassis privately, or designing something other than a stock car, the front end may not necessarily conform to that layout. Mid-engined cars, for example, lack the space constraints of front-engined cars, and hence allow somewhat greater design freedom where the steering is concerned, but the rack still has to be compatible with the suspension.

To find a rack **style** appropriate for your chassis, you must first find a rack **length** that will fit the pivot centers of your suspension linkage. The rack length is dictated by its height in the chassis, and vice versa. Using figure 1 as a guide, draw a line A–A through the inner pivot axes of your upper and lower control arms. The tie rod should pivot from a point along this line. Obviously, the higher the rack is mounted, the longer it will have to be. After picking a trial location and length for the rack, you must verify the tie rod geometry. Follow step A to find where the outer tie rod end should attach. If it turns out to be impossible to attach the tie rod there, determine where you can attach it and follow step B instead.

A: Rack fixed, outer tie rod end open: Project the path of the tie rod from point B (the car's instant center) outward through the rack end. This will indicate where the outer tie rod end (and, of course, the steering arm to which it will attach) should be located on the spindle.

B: Outer tie rod end fixed, rack open: If your steering arm is fixed, then your outer tie rod end location is also fixed and you will have to work backward to establish the rack location, which will in turn determine its length. Project from the outer tie rod end inward to point B. The end of the rack now occurs where you cross line A–A.

Work through A and B as necessary. When the tie rod is aligned as in figure 1 you have arrived at the correct rack length and location.

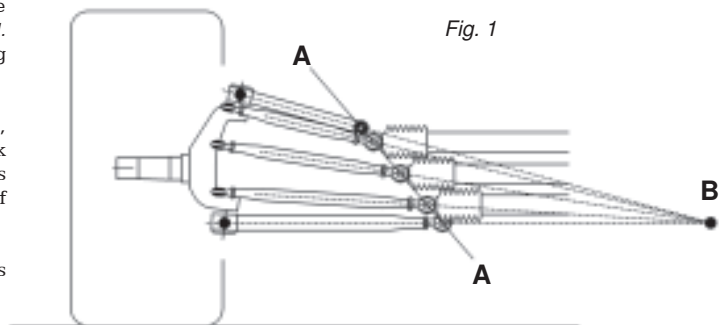

2. Rack style:

In general, the G and H one-piece rack styles are used in heavy-duty applications with rack lengths from 16 to 19-3/4 inches. Type K rack housings are three-piece shrink-fit assemblies and can be stretched to accommodate rack shafts of practically unlimited length. They use the same 1-1/4 rack diameter as the type G and are equally suited to heavy duty applications. Type MR racks are not practical to build any shorter than 22 inches but, like the type K, they have no upper limit and are frequently produced in the 40-inch range. Type MC racks not equipped with power assist can be built in lengths under a foot, again with no upper limit.

3. Pinion location:

Type G and H racks have a fixed pinion location relative to the left end. Type K racks are fixed relative to the left end, and type KR racks, mainly used for right hand drive, are fixed relative to the right end. Type MR and MC racks can be built with the pinion centered or offset to either direction, subject to the limitations imposed by housing length and rack stroke.

4. Rack Stroke:

As a general rule of rack design, the housing should be proportioned so as to support the rack shaft as close to its ends as possible. The shaft will, therefore, protrude from the ends of the housing only far enough to accommodate the required stroke. Type G, H, and K racks have a maximum stroke of 6 inches at a rack length of 18-1/4 inches. A type G or K rack with monobolt rack ends and no cylinder attached can travel slightly farther, depending on the radius of its pinion. At rack lengths shorter than 18-1/4, the stroke is proportionately reduced, because the housing has a fixed minimum length. The MR and MC series can be built for a maximum stroke of 5-1/2 inches. GT cars typically use 4 inches or less, and formula cars sometimes as little as 2 inches. MR and MC racks are normally given a small extra stroke allowance and Delrin travel stops. These can be machined in the event the rack stroke must be offset to compensate for errors in the chassis mounting holes.

5. Ratio:

The "ratio" of a rack and pinion is the distance the rack moves in one turn of the pinion. In the car this linear motion is translated back into rotary motion at the steering arm. The overall steering ratio of the automobile, then, is the ratio of input (in degrees) at the pinion or steering wheel, to output (in degrees) at the steering arm or front wheel. For example, if one turn of the steering wheel produces 36 degrees of turning angle, the steering ratio is 360:36, or 10:1. The length of the steering arm influences the steering ratio as much as the rack does. The shorter the steering arm, the greater the turning angle for a given linear movement, and, consequently, the quicker the steering. A given overall ratio can be arrived at using either the combination of a short (quick) arm with a small (slow) pinion, or the combination of a long (slow) arm with a large (quick) pinion. If a choice is possible within the design envelope of the car, the latter combination is the mechanically superior. A guide to steering ratios appears elsewhere in the technical reference section, but, very generally, the most common rack ratio for road racing is 2 inches per turn, for pavement oval track racing 2-1/2, and for dirt oval track racing 3-1/2 to 4. Consultation on all of the above is available at our tech support line M-F, 8-4:30 MST.

Rack and Pinion Installation for Road Racing

1. Lubrication:

Two grease fittings are provided on type G racks. K series racks will have either one or two. The MR rack has an integral hydraulic cylinder whose function will be impaired if grease should be inadvertently forced into it, so MR (and MC) racks are lubricated by removing the snubber and filling the gear case by hand. All rack types are already packed with a very heavy duty grease, ST-3, which is available from the factory in 14-oz. tubes. We strongly recommend that you lube the rack regularly during the racing season, especially before endurance races. Greases sold at parts stores for automotive use are generally not heavy enough for this purpose, but any grease at all is much better than nothing. Remember: **frequent and generous lubrication of the moving parts** is the single most important thing you can do to ensure maximum steering gear performance. Note: ST-3 must not be used in wheel bearings.

2a. Mounting type G and H racks:

Type G racks bolt to a horizontal triangular plate extending from the front crossmember. Since the heavier V8 classes share the space constraints as well as some of the front-end components of pavement stock cars, the G rack with remote servo is often the most convenient choice. When bolting the unit into the car, use screws long enough to obtain at least **one full inch of thread engagement** (less than this may result in ripping the threads out of the magnesium) and coat the threads with an anti-seize lubricant. Do not use threadlocking adhesives on cap screws that are to be tightened directly into the rack housing. If necessary to clear a large harmonic damper, shim the engine mounts. **Do not grind your rack and pinion housing for clearance.** The section on oval track installation goes into considerable detail on G and H racks.

2b. Mounting type K and KR racks:

The mounting orientation of the type K unit is designed so that its bracket will stiffen the front crossmember when installed in a conventional North American car subframe as front steer. It can also be bolted directly to a bulkhead or plate. A type K unit mounts to an essentially vertical surface, and, since its removal direction usually won't interfere with the engine, can be installed using studs and nuts rather than screws—in which case the studs can be locked in with adhesive. In a car with a subframe, the best bracket construction will consist of a semi-vertical plate extending all the way across the dropped portion of the crossmember and securely welded to its leading edge (which adds considerable rigidity to an area that is usually overly flexible from being thinned down for engine clearance). The mounting plate should be stiff enough to provide support for the housing; **don't expect the housing to stiffen the plate.** A few flat washers under the rack mounting bosses will provide a rearward adjustment allowance (see the section on Ackermann). The up-and-down location of the rack, for purposes of adjusting bump steer or toe pattern, should be arrived at with the bracket temporarily tack-welded in place; also, the holes can be slotted. Slots must be bridged with flat washers to prevent extruding the softer magnesium into them. Again, shim the engine mounts if necessary for engine clearance. **Do not grind your rack and pinion housing for clearance.** Note: A type KR unit is a mirror image of the type K and is intended for front steer in right hand drive cars. Either type can be inverted for use as rear steer of the opposite hand; however, a solid rack shaft for rear steer must have its tie rod holes specially machined relative to the pinion angle. Clevis ends can be reoriented to suit the mounting angle; monoball ends are independent of the mounting angle.

2c. Mounting type MC, MR, and MRC racks:

The MC rack is a lightweight design with general application in open-wheeled formula cars and sports racers, and is built to customer dimensions. The rack is mounted in clamp blocks to the hardpoints on a composite tub, to a machined bulkhead, or to pads on a welded space frame. In its most common form the unit has fairly long, slender proportions and derives most of its rigidity from being mounted to a chassis. It is consequently subject to binding if drawn down against uneven or misaligned surfaces. It must be tested for freedom of movement **while its mounting clamps are being tightened**, particularly in cases where three mounts are used. If binding occurs, check under the clamp blocks with a feeler gauge and shim until the rack is brought into alignment and the bind removed. The MR rack is an integrated power unit, also custom built for specific applications. Although it is physically larger than the MC, the same precautions against misalignment must be taken while bolting it down. Both rack types are too light to be able to force an uneven surface into flatness. The MRC combination is an MC rack built with integral cylinder and remote servo.

Although for some unknown reason it has become traditional in road racing to run without rack boots, it should be obvious that any sliding mechanism—such as a rack—will perform better and last longer if shielded from abrasive dust and dirt. It is, moreover, extremely dangerous to run without boots if the rack teeth will be even momentarily exposed during any part of the rack stroke. All Woodward racks are made with mounting provisions for, and are supplied with, rubber boots. MR and MC rack boots have a reduced end that will seal against a typical 5/8" diameter tie rod. Put the rod through the boot before screwing in the rod end. If the seal is completely airtight, cut a small (1/16") breather hole in each boot. The boot will protect the clevis and rod end assembly as well as the moving end of the rack shaft.

Fig. 2

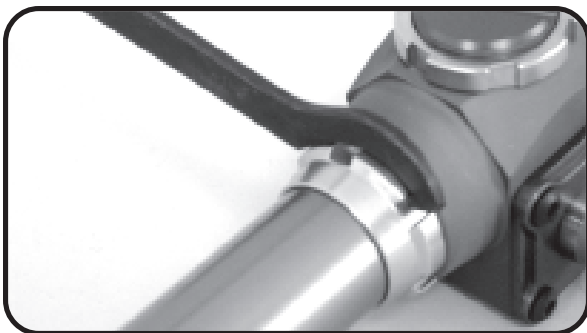

Both MR and MC rack housings can be adjusted for length, to allow for variations in mounting hole locations on the chassis. Just break loose the jam nut with a hook-type spanner wrench, screw one of the main tubes in or out, and retighten the nut.

Fig. 3

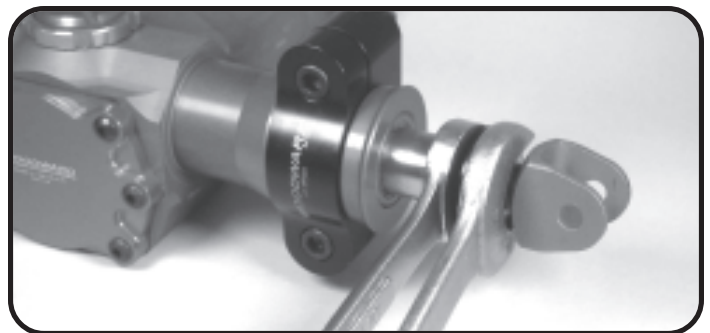

When setting the clevises, use a 3/4" (19mm) backup wrench to keep the rack shaft from turning. Be sure to remove any burrs, as these will interfere with retraction of the shaft into the bushings. **REPEAT: Never loosen or tighten any rack end fittings without a backup wrench.**

3. Plumbing power steering (refer to the Plumbing Schematic on page 122):

WARNING: Never use stainless-braid covered neoprene hose (the kind with red and blue ends, commonly used for fuel lines, dry sumps, etc.) on power steering. Its ends will blow off under pressure. Stainless-braid covered TFE hose of the type used for brake lines has steel ends and is OK. Hose used for power steering must be rated for 1500 PSI working pressure. The hose ends can be either the crimped or reusable type, as long as they are steel. Note: we strongly recommend the use of hose rather than "hard line"—in this and other race car applications—because of its greater tolerance of vibration and impulse loads.

Remote servo racks: On a G, K, or MRC power-assisted rack with remote servo, connect the hose from the servo port "I" to the **left turn** side of the rack cylinder. In **left hand/front steer** and **right hand/rear steer** configurations this port will be on the **right** side of the car. In **left hand/rear steer** and **right hand/front steer** configurations it will be on the **left**. Next, connect the servo "P" port to the pump output and the "T" port to the tank return. MRC racks use -4 hoses to the cylinder ports, but the tank and pump connections should always be made with -6 (see fig. 4). Type G and K units use -6 throughout.

Integral servo racks: An MR or H power-assisted rack is already plumbed from the servo to the cylinder. With no cylinder connections to make, it is only necessary to connect the servo "P" port to the pump output, and the "T" port to the tank return.

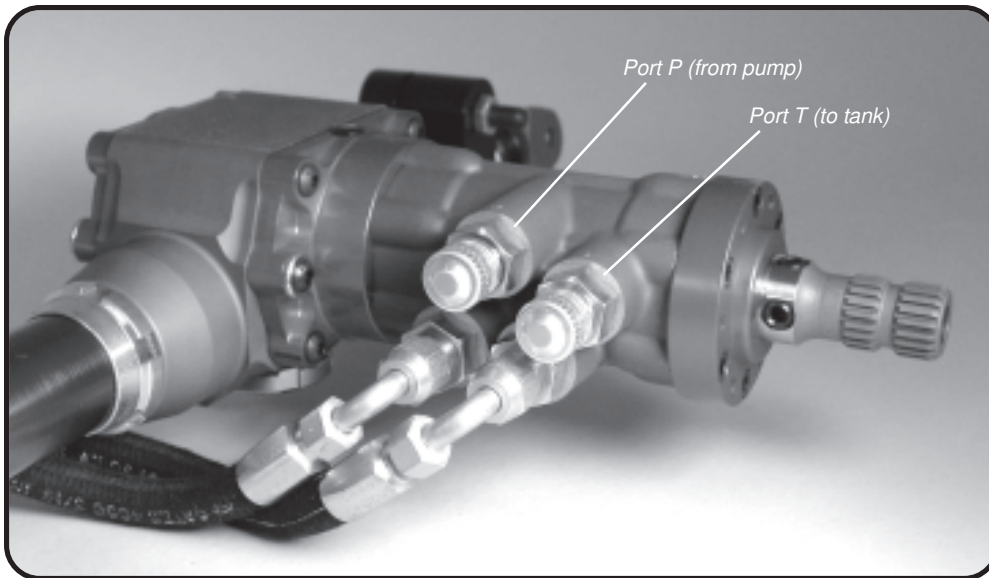

MR racks have -4 hoses connecting to the cylinder ports, but the tank and pump connections should always be made with -6 (see fig. 4). Type H racks use -6 throughout. The fluid port layout on an MR rack is the same as on an inline Woodward servo, except that the cylinder is plumbed with -4 hose.

While the return line to the tank normally operates at very low pressure, we recommend using pressure hose for this line as a safety precaution. The steel ends are much more resistant to separation in a crash than ordinary push-lock hose, and the weight penalty is insignificant.

Fig. 4

Many if not most installations of MR racks utilize an electric pump such as Renault, Toyota, or Porsche. Output fittings are available from various sources to adapt -6 hose to the pump output. Check the bore of the aftermarket fitting and make sure it is the same as the original. Note: All DC motors slow down under load, so, unlike an engine-driven pump, the volume from an electric pump actually decreases with rising pressure. This characteristic would make conventional electric PS pumps unsuitable for high rack velocities; however, at the rack ratios normally used in road racing, especially with the MR rack, none of the above pumps has ever exhibited any deficiency.

A servo installed inline should have its centering adjustment set screws at the end toward the driver, just like the integral servo rack in fig. 4. **If an inline servo is installed backward, left and right functions will be reversed.** Upon initial startup this condition may cause the steering wheel to snap violently to full lock in one direction, so take care to get it plumbed correctly first. A more detailed discussion of power steering appears in the "Power Steering System Tech" section.

4. Adjusting bump steer:

Racks in the G and K series are frequently used with offset tie rods, that is, spherical rod ends spaced above the rack on vertical bolts. Although the bolts are popularly said to be in "single shear," they're actually loaded in bending rather than shear. While their large size (5/8") has proven reliable in terms of breaking strength, excessive offset of the rod end above the rack shaft centerline may provide enough leverage to allow deflection under load, either through flexion of the bolt or rotation of the rack shaft. Therefore, when adjusting your bump steer pattern by adding spacers under the tie rod ends, it is important to avoid spacing the inner ends any higher than absolutely necessary, as excessive spacing merely increases the leverage acting to deflect them.

Since this deflection only occurs under dynamic conditions (i.e., when actually racing) it will not be evident during bump steer measurement. It is thus possible to waste much time stacking spacers in pursuit of some theoretically ideal set of numbers and end up with a sufficiently elastic linkage as to render the numbers meaningless. From an engineering viewpoint, the best method of tie rod attachment is on center, using monoballs or clevises, which eliminates both rotating moment and deflection. Adjusting the inner tie rod ends in those cases is a matter of using spacers under the rack housing. Type K racks mount against an essentially vertical surface, and can be repositioned for bump steer with slotted mounting holes. Type MC and MR racks can be repositioned with either slots or spacers, depending on the orientation of the clamp blocks. **Note that MC and MR units are intended for use only with centered tie rods and their design does not allow for off-center loading.**

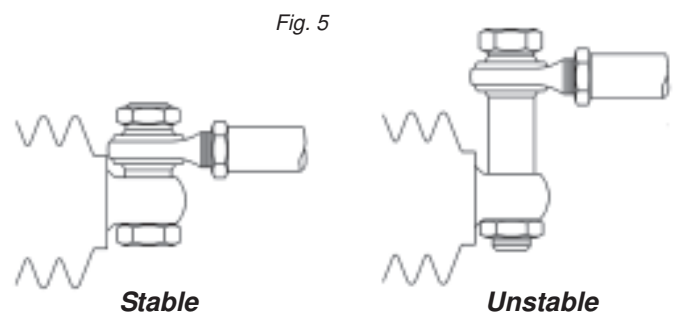

Fig. 5

Rack and Pinion Installation for Oval Track Racing

Except for the references to asymmetrical front end geometry, the following material also applies to G and H racks used in road racing.

1. Lubrication:

Two grease fittings are provided on G, H, D, and DH racks so that at least one can be reached in the car. Most new dirt cars are built with a skid plate of some kind under the rack. Put a hole in the skid plate so you can reach the fitting. The rack and pinion is already packed with a very heavy duty grease, ST-3, which is available from the factory in 14-oz. tubes. We strongly recommend that you lube the rack weekly during the racing season. Greases sold at parts stores for automotive use are generally not heavy enough for this purpose, but are much better than nothing. Remember: **frequent and generous lubrication of the moving parts** is the single most important thing you can do to ensure maximum steering gear performance. Check the upper and lower ball joints frequently, as the steering won't work properly if these are bent or frozen. Note: ST-3 must not be used in wheel bearings.

2a. Mounting type G racks:

When bolting a type G unit into the car, use screws long enough to obtain at least **one full inch of thread engagement** (less than this may result in ripping the threads out of the magnesium) and coat the threads with an anti-seize lubricant. Do not use threadlocking adhesives on cap screws that are to be tightened directly into the rack housing. To lock cap screws against backing out, use split-ring lock washers. It is also essential that the mounting bracket be reasonably flat and that it not interfere with the housing. On older chassis the mounting bracket may be too wide to clear a type G rack housing, in which case you can either use shim washers under the housing or modify the bracket for proper clearance. Make sure to have at least a quarter inch of daylight between the rack and your crank pulley (engines tend to shift during impacts, and if the edge of a large pulley or harmonic balancer should contact the rack it can bend the crankshaft snout). Shim the engine mounts if necessary. **Do not grind your rack and pinion for clearance.** Anti-seize should also be used on the pinion spline.

2b. Mounting type H racks:

The same procedures apply as above, except that additional clearance is needed for the lowermost servo flange bolt heads. If you order a new car with a type H or DH integral-servo rack, most builders now either have a special crossmember for it or they modify their standard one with notches and suitable reinforcement, but you will usually have to tell them in advance. If you do your own modification, don't be shy about backing up your clearance cuts with gussets or whatever it takes. Many chassis already lack sufficient rigidity in that area, and adding a pound or two won't hurt one bit. High-powered steering can sometimes be observed actually flexing a front crossmember.

Figure 6 below is an example of a mechanically sound installation in a typical dirt chassis. Some particular points are worth noting. A double crossmember (made of two small rectangular tubes) has been narrowed and tied together with four spacers for increased rigidity. A piece of 1/8" plate (with a few drain holes, of course) connects the front and rear tubes. This backs up the rack plate and provides reinforcement for the clearance notch described above. The main reason for these structural modifications is to allow the rack to be set **rearward of the steering arm eyes**. A single-tube crossmember generally allows much more freedom for rack placement in the fore and aft direction, but can be very difficult to adequately reinforce if you have to cut it for clearance. A better solution is to raise the rack until it clears and put the steering arms at the proper height. Where on-center ends (such as monoballs or clevises) are used in lieu of spaced-up rod ends, the rack will have to be raised anyway, solving any bottom clearance problem.

The layout in figure 6 develops its greatest stability at its maximum steering angle. It can also be seen from a close look at the boots that the housing is slightly offset so that, even with the inner tie rod ends centered on the control arm pivots, more stroke is available to the right. With the rack set back, the alignment of the tie rods actually improves as the wheels are steered, until the rod being loaded in buckling, or compression, is directly in line with the rack shaft. This geometry has the highest resistance to deflection and toe change right at the point of highest load.

On dirt the highest load occurs at full countersteer (which can be as much as 45 degrees) with all the front weight transferred onto the right wheel (which, as often as not, is already bouncing through ruts). Because of the extreme steering angle involved, the tie rod alignment issue is easy to visualize.

The situation with respect to pavement is a good deal more subtle. While a pavement car doesn't get countersteered, it still encounters the greatest loads on its steering during cornering. Its rack needs to be set back far enough to achieve parallel alignment under load at whatever turning angle the front wheels will see while pulling maximum G force. Like with a dirt car, you can figure this out by turning the wheel to your accustomed hand position with the car up on jack stands while observing the angle of the tie rods. That will show if there is any misalignment worth correcting by moving the rack back in the car. As a rule of thumb, the total amount of rack setback necessary on a pavement car may be half an inch or less, that on a dirt car as much as an inch and a half.

Fig. 6

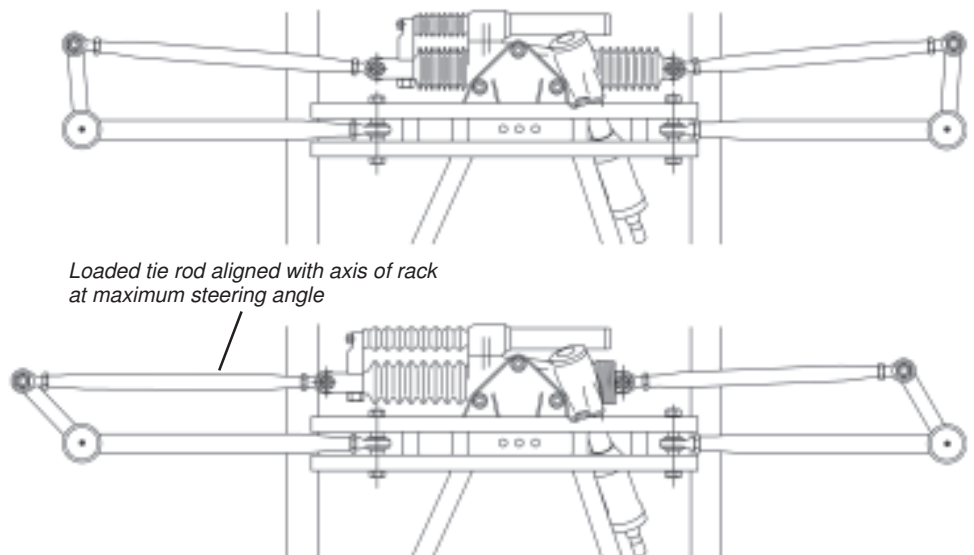

2c. Mounting type D and DH racks:

These are the same as G and H types respectively; they require the same clearance provisions in the pinion area, but 1/4 inch lower because of their larger gears.

3. Adjusting tie rods:

Remember to install and adjust your tie rods so as to properly utilize the stroke of the rack. For example, on a typical dirt car (which requires more steering to the right than to the left) make sure the left tie rod is not too long or it will act as a travel stop against the rack housing, *which will limit your steering to the right*. This condition is shown below in figure 7 (greatly exaggerated for clarity) where the rack housing is located correctly but the tie rods and control arms are grossly mismatched. Not only would this car exhibit bump steer, but the steering could not possibly be turned to the right. In the case of power-assisted steering, of course, the left tie rod would be repeatedly driven against the housing with a thousand pounds' force.

Fig. 7

(Correct rack mounting but incorrect tie rod lengths)

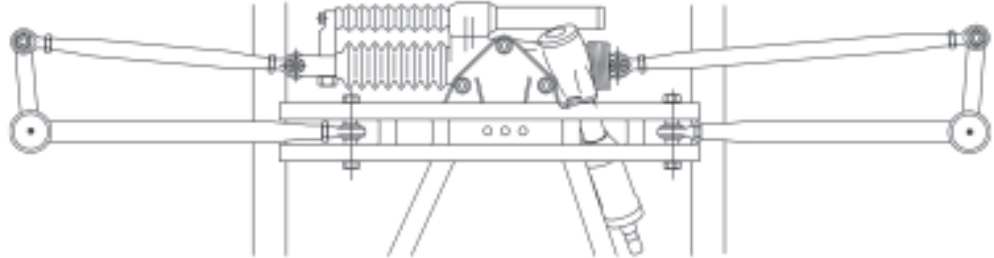

To correct this condition on most cars, you can simply adjust the left sleeve shorter and the right sleeve longer by an equal amount until the stroke limitation is gone—although in the bad example above there would not be nearly enough adjustment to fix it; you would have to replace the tie rods themselves. After correction and readjustment you should have enough stroke available in both directions, and the tie rod pivot points should also be approximately centered on the lower control arm pivot points (at least on the right side). If they are badly off, then bump steer will be unavoidable. The rods and arms will travel in conflicting arcs, causing the wheels to steer as the suspension moves through bump and rebound (whence the term bump steer). If you can't obtain both freedom from bump steer *and* a reasonable stroke allowance both ways (that is, assuming the rack is the correct length for the chassis, which is not always a safe assumption) then the rack is mounted too far to one side as in the example in figure 8 below (again, shown greatly exaggerated for clarity):

Fig. 8

(Correct tie rod lengths but incorrect rack mounting)

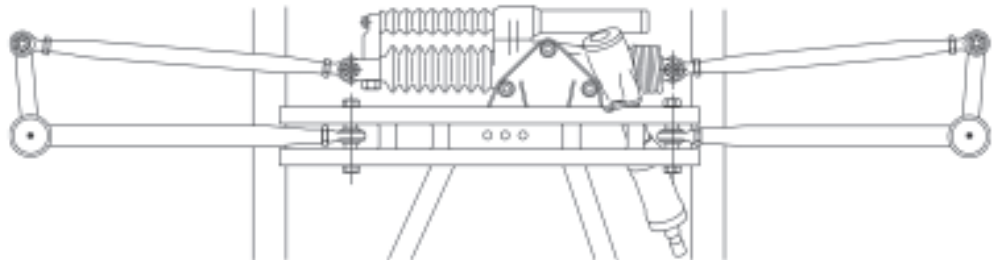

You can avoid a great deal of trouble here through careful and reasoned observation. Note that, because the pivot points of the tie rods and control arms in figure 8 are fairly well centered on each other, a bump steer indicator would likely show a perfectly good toe pattern. However, a bump steer test will not detect the interference with the steering stroke. Take a good look at your rack location with the steering centered. If it looks anything like figure 8, rely on common sense—just saw off the bracket and move it.

4. Connecting the power assist (refer to the Plumbing Schematic on page 122):

Type H and DH integral-servo racks already have cylinder hoses connected to their servo ports. With a Type G or D rack and remote servo, connect the hose from the servo port "L" to the **left turn** side of the rack cylinder (the "head" end, not the driver's left). Connect the "R" port on the servo to the **right turn** side of the cylinder (the "blind" end with the plug). The "L" and "R" designations apply only if the servo is installed with its centering adjustment set screws toward the driver. **If the servo is installed backward, left and right will be reversed.** Upon initial startup this condition may cause the steering wheel to snap violently to full lock in one direction, so take care to get it plumbed correctly first. Connect port "P" to the hose from the pump output, and port "T" to the hose returning to the tank. For an extensive discussion, see the *Power Steering Tech* section.

5. Using tie rod spacers:

When adjusting your bump steer pattern by adding spacers under the tie rod ends, it is best to avoid spacing the inner ends any higher than absolutely necessary, as this merely increases the leverage acting to deflect them. Since this deflection only occurs under dynamic conditions (i.e., when actually racing) it will not be evident during bump steer measurement. It is thus possible to waste much time stacking spacers in pursuit of some theoretically ideal set of numbers and end up with a sufficiently elastic linkage as to render the numbers meaningless.

Fig. 9

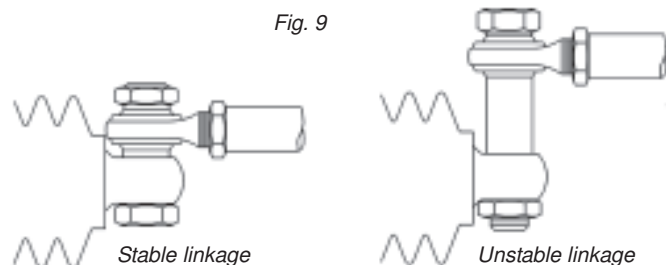

If you have to raise the inner tie rod end location, the best method by far is to raise the entire rack by installing a shim plate or flat washers under the housing. Otherwise, try to do the shimming at the *outer* tie rod end. If the stack gets beyond an inch or so, use *steel* spacers and tack-weld them to the steering arms. This will significantly reduce the bending load on the bolt. **Remember, above all, that good geometry cannot be obtained without a stable and mechanically sound steering linkage!**

6. Toe and bump steer geometry:

This is not intended to be an exhaustive treatment of the subject, as would be required for cars with four-wheel independent suspension. The basic rules of thumb for stock cars on oval tracks are: **bump steer should be minimized, and any bump steer should occur as toe-out rather than toe-in.** The phenomenon itself can be difficult to visualize, and the amount of bump steer that can benefit handling is rather small and difficult to measure. It involves the tendency of the suspension to change the parallelism of the front wheels as they move up and down, and the need to limit this effect to 1/16 or less, and to make it occur in the right direction. To get in the right frame of mind for this, a good place to start is the accurate measurement of *static toe*, which is the amount by which the planes of rotation of the front wheels deviate from parallel with the steering pointed straight ahead.

To establish the plane of rotation of a tire, you have to scribe it. The sidewall isn't a particularly reliable reference surface, because if either the tire or the wheel has been used, especially on a stock car, the sidewall or bead area may run out by more than the amount you want to measure. Even if wheel and tire are both brand new, they probably run out. In fact, the hub itself may run out. Scribing the tire is the only method that can be counted on for accuracy.

Raise the front wheels and rub chalk all the way around the middle of the tread surface. Rotate the wheel while approaching it with a rigidly supported scriber (a sharpened nail through a two by four will work if somebody can stand on it to keep it from moving when it contacts the tire). The object is to scratch as fine a line as possible around the circumference of the tire, and that the line not wander out of true. Commercial tire scribers are spring-loaded to allow scribing egg-shaped tires; if you use one, be sure the point will not spring away sideways or your line will wander. Scribe both tires until you have sharp true-running lines, then set the car back down. The measurement to be taken now is a *comparison of the distance between the lines at the front and rear of the tires, at centerline height.* The drawing below shows an easy-to-make gauge which is used by sliding it under the car and standing it up against the tires.

Fig. 10

A technique for accurate toe measurement:

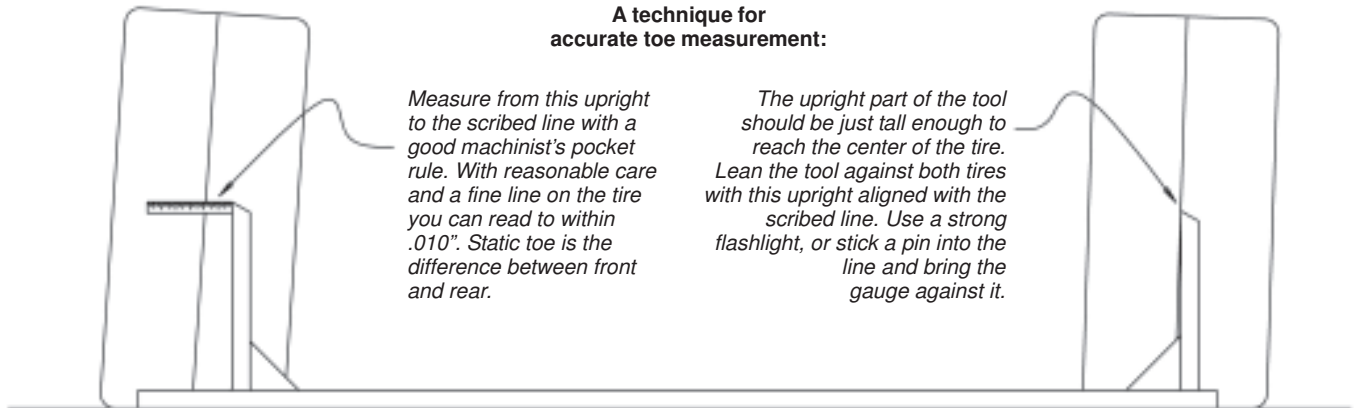

Measure from this upright to the scribed line with a good machinist's pocket rule. With reasonable care and a fine line on the tire you can read to within .010". Static toe is the difference between front and rear.

The upright part of the tool should be just tall enough to reach the center of the tire. Lean the tool against both tires with this upright aligned with the scribed line. Use a strong flashlight, or stick a pin into the line and bring the gauge against it.

You can see that the camber of the front tires would make it useless to compare measurements made at different heights. A tool like this will provide very good repeatability, provided the wheels are not disturbed between measurements taken at front and rear.

Using the tool and measuring at the center height of the tire may reveal that the toe as previously set has been off by as much as half an inch. In some cases it may have been toed in, which tends to make the car dart, especially under braking. Race cars are usually toed out slightly to induce a tiny push. The above-described procedure is accurate enough to distinguish that 1/32" that may be sufficient for stability, from the 1/4" that greatly overdoes it and scrubs off speed. Remember, the important characteristic of a wheel is that it rolls. Dragging it sideways any more than you absolutely have to is, well, counterproductive.

After getting accustomed to the degree of care necessary to obtain a reliable, repeatable static toe setting, you can progress to measuring the dynamic change the toe goes through on the race track. This is nothing more than a toe measurement, performed at intervals of up (bump) and down (droop) travel, using ride height (where you set the static toe) as the baseline. One wheel is tested at a time. Strictly speaking, bump (or roll) "steer" should be thought of as **toe change during suspension travel**, since its "steering" action (felt as a loose or push condition in the corners) has virtually no relation to the steering wheel.

Bump steer and roll steer are the same thing. Whether the "steering" action occurs with the chassis level and stationary and the tire rising, or with the chassis in a rolled attitude with the tire stationary and the chassis dropping, the motion of the suspension and steering linkage is identical *relative to the chassis*. The usual way to analyze the motion is to block up the chassis and jack the suspension linkage up and down with the spring removed. Likewise, the motion is usually represented in drawings as though the chassis were stationary, because the arcs of movement are easier to visualize (3-D software can move the chassis with the tires planted, or vice versa...but only if you have digitally modeled the chassis).

In general, bump steer should be minimized. Leaving aside for the moment the fact that some small amount of bump toe-out can be useful, it is in general more difficult to steer if the normal up-and-down suspension travel causes the wheels to turn in and out independently of the steering wheel than if it does not. Bump steer happens when the various suspension links (control arms and tie rods) do not act in concert where they attach to the chassis and spindle. The reasons for that can be (1) mismatched lengths of adjacent links—on a stock car, that's usually the tie rod and lower control arm—or (2) mismatched arcs of movement of those adjacent links or (3) some combination of the two.

This dynamic toe change can be measured very accurately by means of a bump steer gauge, which is basically a pair of dial indicators bearing on a flat plate attached to the spindle or hub in place of a wheel. The flat plate represents the plane of rotation of the tire and moves up and down with bump and droop. The indicators are stationary, and will read any deviation from parallel at the front and rear of the plate. With the front springs and shocks removed and the chassis supported at ride height, the spindle is raised and lowered with a floor jack. Care should be taken not to disturb the chassis

or the tool. There are plenty of bump steer measuring tools commercially available, so with this edition of the catalog we have eliminated the instructions on how to build one. The important thing is for the plate to be flat enough to accurately reproduce the plane of rotation, and wide enough to equal the diameter of the tire. The goal here is to obtain measurements having the *same basis* as the static toe measurement which you made exactly at the tire's diameter after scribing the tread.

Two or three inches of bump and one inch of droop on the right front, and an inch of bump and two or three inches of droop on the left front, is the range of travel usually tested on a stock car. If your car goes through more travel than that (many dirt cars do) you might as well test it over its full range. Record the indicator readings at, say, half-inch intervals on some graph paper and connect the dots. The resulting pattern is the *bump steer curve*. The patterns in figure 10 indicate certain conditions:

Fig. 10

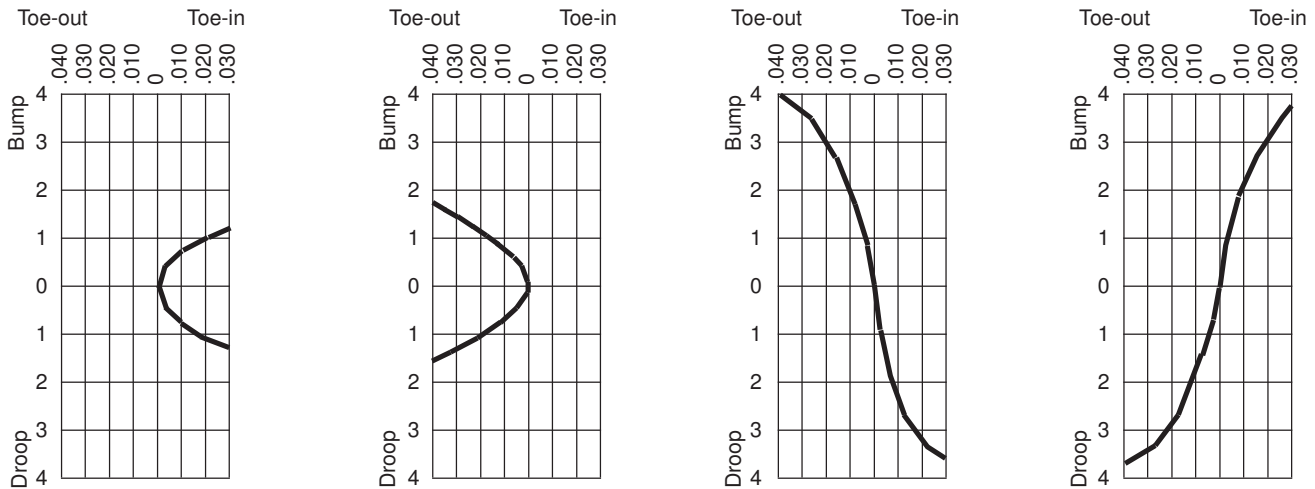

A. Tie rod is too SHORT
(its pivot is **OUTBOARD** of the lower control arm; the rack is too long or is off center)

B. Tie rod is too LONG
(its pivot is **INBOARD** of the lower control arm; the rack is too short or is off center)

C. Tie rod leads DOWNHILL
from rack to spindle (the steering arm is too low or the rack is too high)

D. Tie rod leads UPHILL
from rack to spindle (the rack is too low or the steering arm is too high)

In the first two instances above, the amount of bump steer present goes off the scale, and is large enough to be demonstrated by jumping up and down on the bumper and watching the tires turn in and out. Should that actually be the case with your car, the front end may be outside the range where easy correction would be possible by shimming or adjusting. So, before setting up to plot bump steer curves, it may prove more practical to simply observe the action of the front end, comparing it with the following drawings (all show the right front of a front steer car) to determine whether any gross changes are needed to get it into the ball park (Note: to simplify this discussion, the effects of caster, camber gain, and anti-dive are left out).

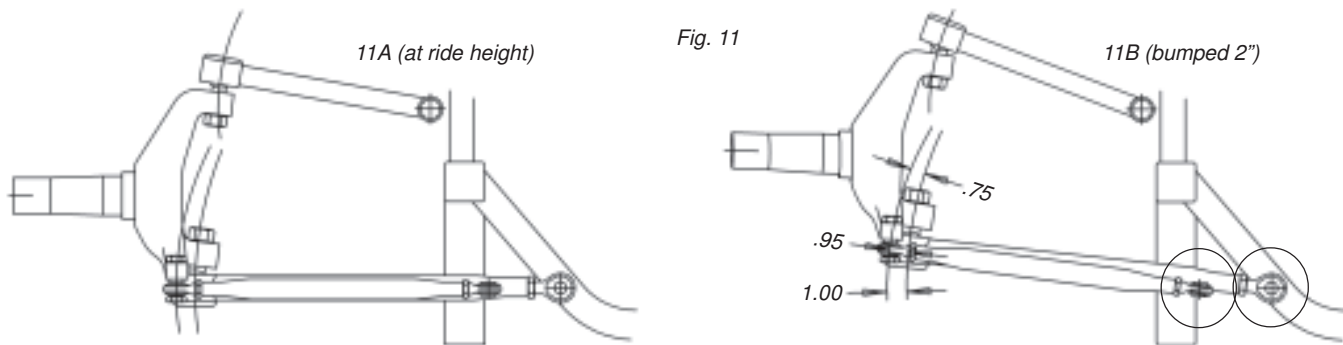

Figure 11 shows a tie rod that is too short. It follows a shorter arc than the lower control arm. Since these two links are in parallel alignment at A (ride height) everything looks fine at first glance. However, since the tie rod pivot point is outboard of the control arm pivot point, their two arcs converge, which will pull the steering arm inward relative to the lower ball joint. At B (two inches of bump) the steering arm has been pulled inward .050. Note that this is not .050 toe change; this is just a movement of the steering arm. It is multiplied out at the tire. With a (fairly typical) 5-3/4 inch steering arm and 29 inch tire, the front of the tire would steer in 1/8 and the rear out 1/8, producing an actual toe change at the tire of over a quarter inch.

At the extreme end of its upward travel this tie rod will have pulled the steering arm inward by .250. Repeating the arithmetic we see a toe change at the tire *which now exceeds five degrees of steering!* Bear in mind that that is just on the right side. Even if the other side were error-free and this car never saw more than three inches of bump travel, it would still be virtually uncontrollable.

As soon as a left turn begins, any chassis will naturally roll to the right. This roll puts the right front into bump. In the above case, the steering arm is pulled to the left, *causing a sharper turn than was input by the driver.* The sharper turn causes more body roll, which in turn causes more steer, resulting in still more roll, and so on. The right front "tucks under" and the car darts in the turn, or spins out. The process happens very quickly after the initial left-turn movement of the steering wheel. Because it is so hard to keep up with and leads to constant overcorrection, an impression can be created that the steering ratio is too quick. This defect is called **roll oversteer**.

Although most people would instinctively describe this condition as “loose”, it cannot be cured by changing the weight and balance, or tightening the car at the rear, or installing slower steering (unless, of course, you were to slow the car down so far that it would no longer roll, which would merely disguise the problem).

The next example is that of a tie rod that is too long; its pivot point is located inboard of the control arm pivot. Swinging through a longer arc, it pushes the steering arm away during bump travel. Its effect on handling is—predictably—the opposite of too short a tie rod; that is, a tendency to *resist* input from the steering wheel rather than to exaggerate it. The more you turn left, the more the chassis roll will toe the right front outward, detracting from the leftward input you made at the steering wheel. Often described as a “push” condition, this defect is **roll understeer**.

In figure 12 the pivot points have been misaligned vertically as well as horizontally, which adds considerably to the toe change that might otherwise be expected. Rolled into 2 inches of bump as at B, this car would steer sluggishly. It would also probably get in the wall a lot.

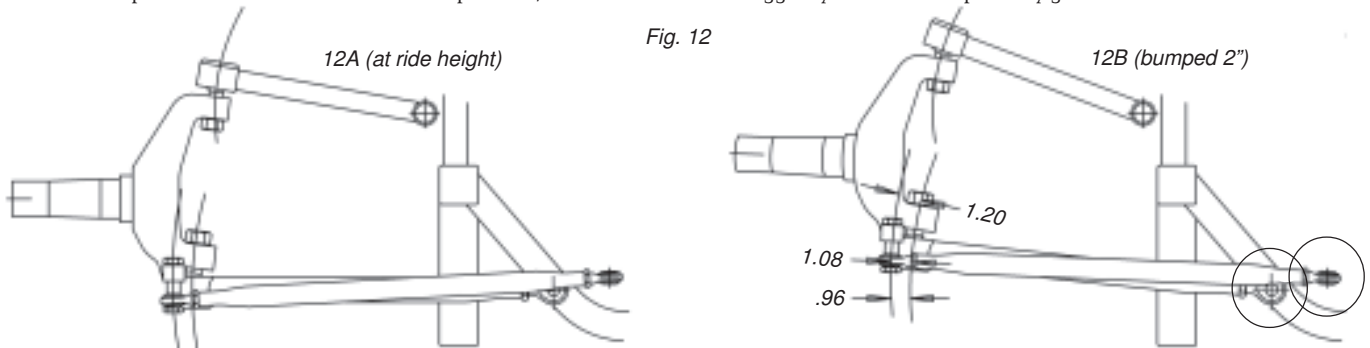

Fig. 12

Without belaboring the point, it should be mentioned that a “push” condition when the chassis rolls is, in general, a much steadier state than the oversteering described in the previous example, because toed-out tires tend to dampen steering wheel input whereas toed-in tires tend to exaggerate it. Unfortunately, it’s also a less obvious defect and therefore harder to diagnose from the driver’s seat.

If the bump toe-out can be reduced to very small amounts, however, the steering response livens up and the only part of the cornering action still dampened is the rotation of the car into oversteer, where some delay is a distinct advantage. On dirt, the car will be easier to control in a slide. This useful region is in the neighborhood of .010 toe-out per inch of travel, and plotting it requires the dial-indicator rig described earlier. In order to be adjustable to that degree of accuracy, the tie rod pivot point will have to match that of the lower control arm more closely, as in figure 13.

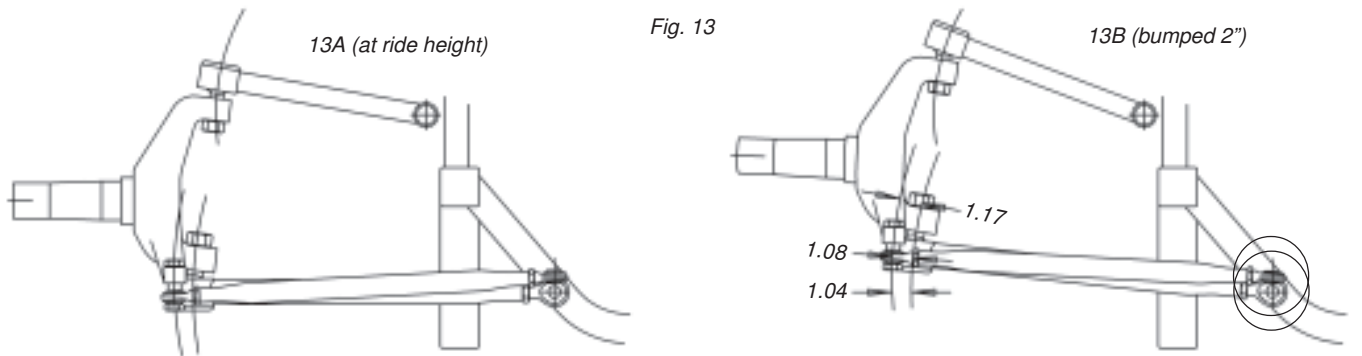
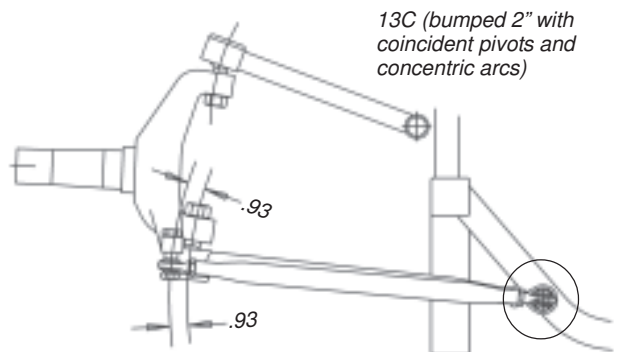

Fig. 13

Here things are looking better. The paths of tie rod and lower control arm can still be clearly seen to diverge during bump travel, but in the first two inches the change is down to .020 per inch, which is less than 1/16 per inch out at the tire. That is close enough to plot with a dial-indicator rig and can be fine-tuned by adding or removing shims. A close look will show that the inner pivot points of tie rod and lower control arm are much more closely aligned than in the previous examples, except for the tie rod’s inner end still being noticeably the higher. We can further reduce the toe change by dropping the inner tie rod end until its pivot point finally coincides with that of the lower control arm, as in figure 13C. On just about any late model stock car, making these arcs concentric will eliminate most of the bump steer. The remainder will be due to the location of the outer tie rod end and the influence of caster and camber gain on the spindle path. The usual combination inherently generates toe-out, but the amount is small enough that you can easily set it within your desired limits by adding or removing shims at the steering arm.

Bump toe-out of 1/32 in three inches (measured out at the tire) is not at all detrimental to handling on a stock car. On pavement, toe-out keeps the tie rods of a front-steer car loaded in tension down the chutes and helps damp the oscillations produced by braking, especially on cars with rubber bushings in the control arms. On dirt, it tends to make a slide smoother. That said, there is certainly nothing wrong with having *zero* bump steer if you can achieve it. Zero bump steer means that your steering geometry cannot be influenced by changes in shock travel, moment arm, or ride height, which is a good thing. If your car goes 250 MPH it may be more of a mandatory thing.

While bump steer gets a lot of mention in discussions of race car handling, there is still another part of the steering geometry, the Ackermann or steering differential, which has a more immediate effect on handling because it dictates how easily and positively you can *initiate* a turn.



13C (bumped 2") with coincident pivots and concentric arcs)

NOTE: The following chapter first began to appear in this catalog several years ago, apparently to good effect—the major chassis builders have since corrected most of the rack placement problems cited, and at least one now provides an optional set of rack mounting holes for increasing the Ackermann. However, there are still a good many cars out there built according to earlier designs, so the information still applies.

7. Ackermann geometry (making it turn left):

A frequently encountered problem with North American stock cars, especially on dirt, is the inability to initiate a left turn with the steering wheel. In order for the car to assume a fast cornering attitude, it first has to point to the left. If the car exhibits sluggish entry and will not rotate (especially on very short race tracks) it may have insufficient steering differential, or Ackermann.

In order for your race car to get into a corner, the inside front wheel must be steered at a greater angle than the outside wheel, *because it has to start a sharper turn than the outside wheel*. The tighter the turn, the greater the required angle. A simple test for Ackermann is to push the car around the parking lot (disengage one axle if you use a spool) while reaching through the window and turning the steering wheel to the left. If it seems less responsive than a street vehicle, or if the front tires chirp or skip, it probably has insufficient Ackermann. It may even have *reverse Ackermann* (see below), which makes a car so unresponsive to the steering wheel that its effect on corner entry cannot be compensated for by any amount of bump steer, roll steer, or tire temperature, all of which happen too late. Perfectly parallel, non-Ackermann steering (with both wheels rolling tangent to the arc of the turn like on a railroad car) works fine on a superspeedway but not on a bull ring, for the simple reason that your tires are large, elastic and conformable, and movement of their contact patches lags behind that of the wheels they are mounted on. To achieve a quick and positive change of direction they must be forced or led slightly in advance of the path you intend for them to take. This is done with linkage geometry, which in a car with rack and pinion steering results from the relative position of (and the operating angles between) the rack and the steering arms.

Most professional short track chassis builders incorporate steering differential into their front ends, one way or another. While with pavement cars it is often possible to ignore those details of geometry which involve steering to the right, in the construction of dirt late models sometimes both directions get ignored. In either case, the rack may wind up installed in the chassis without reference to the location of the steering arms. Frequently its installed position is subordinated to that of a radiator, harmonic damper, or other component, without the builder realizing that the linkage geometry of the race car has been compromised. In the case of a used race car, somebody may have installed spindles with shorter steering arms, and, if the rack has not been relocated rearward by a corresponding amount, the Ackermann will be gone (assuming the car had any to begin with).

Installing the rack ahead of the steering arms reduces the mechanical efficiency of the linkage on the outside wheel as the turning angle increases. This is the most serious mistake seen on race car front ends. Drag cars are often built this way, but are not expected to do much steering at high speed; when they do they frequently wreck. In figure 14 below, note that the operating angle between the tie rod and steering arm on the right front (in the circled area) is getting uncomfortably close to the self-locking point. Since this is the loaded wheel, countersteering with this geometry can feel like releasing a pair of Vise-grips.

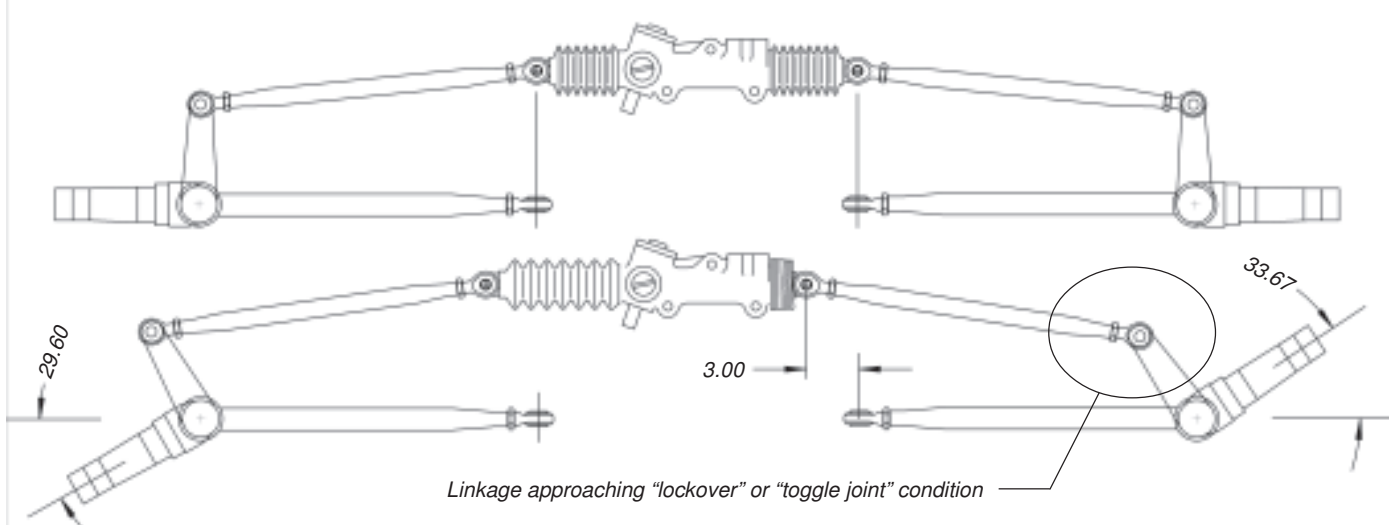

Fig. 14

Aside from reduced leverage at full left lock, the wheels here are being steered with reverse Ackermann. The turning angle of the outer wheel is greater than that of the inner wheel, which is exactly backward. Once in the turn this car will be highly unpredictable because of the toe-in created by the steering linkage. The effect is the same as toe-in caused by bump steer, with the very important distinction that it is created mechanically, by the linkage, and will occur whenever the steering wheel is turned, regardless of the speed or roll attitude of the car.

The first step is to correct the wide tie-rod-to-steering-arm angle by moving the rack and pinion back in the car. How far back? Twenty-five years ago, a good many new race cars were built with the rack and tie rods on a common centerline, in the apparent expectation that a parallel linkage would result and the front wheels steer exactly together—which also conformed to the then-popular anti-Ackermann theory. Unfortunately, not only will a rack *not* reproduce the motion of a center link-and-idler setup, it will generate reverse Ackermann if aligned with the tie rods. To have sufficient Ackermann geometry to get a short track car pointed into the turns, the rack should be *behind* the tie rods.

The second step is to obtain Ackermann steering by moving the outer tie rod ends outside the lower ball joints. This conflicts with the need to have the brake rotors exposed to as much airflow as possible; on many cars the rotors or the wheel rims interfere with the tie rods, preventing their placement as far outward as needed (this problem remains unresolved in some stock car construction even today). A good rule of thumb for short track cars is half an inch out for every six inches of steering arm length, which is coincidentally about as far as you can go without scraping the inside of the wheel. Figures 15 through 19 progress through various corrections of a front end to improve the Ackermann.

On frames based on the 1971 Camaro it was impossible to locate a rack and pinion far enough to the rear, so it became common to fabricate spindles with a shorter steering arm on the left side, and give a faster steering ratio to the left wheel. This makes the front wheels toe out when turned left, at a rate determined by the difference in length of the two steering arms, and creates Ackermann to the left:

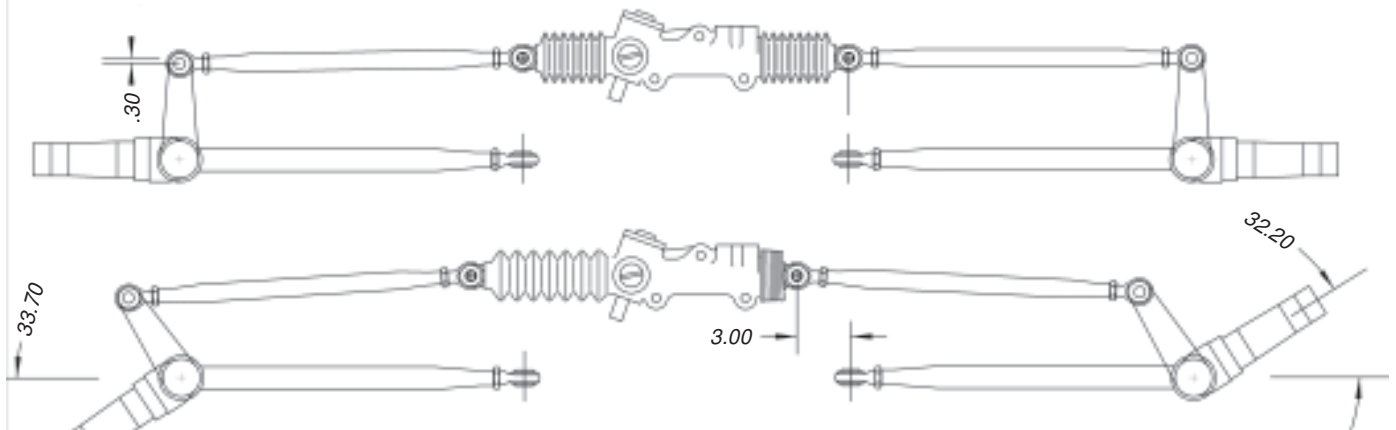

Fig. 15

Unfortunately, however, the shorter steering on the left side makes the wheels toe IN when turned back to the right:

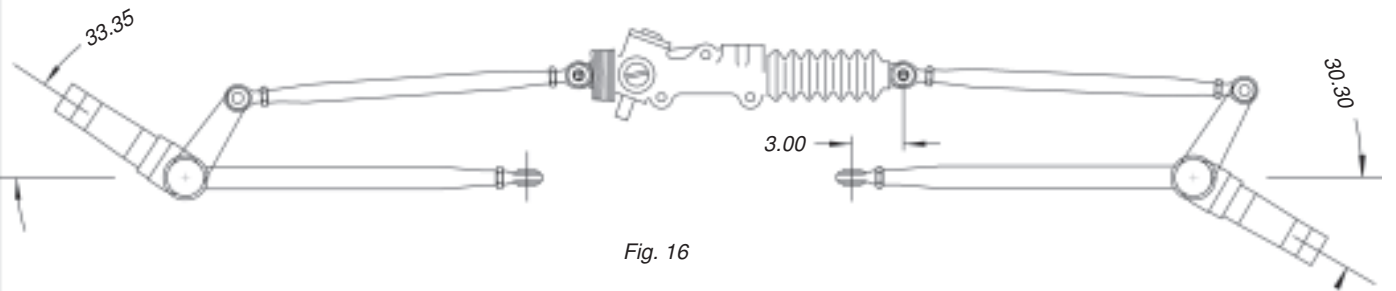

Fig. 16

On pavement this defect is irrelevant, since the toe-in won't happen unless the car should rotate beyond the point of neutral steering and into the realm of countersteering into a slide angle. On dirt, however, countersteering is the prevailing condition. Considering the known effects of toe-out (stable state/push) and toe-in (unstable state/loose), it's easy to see that unequal steering arms tend to shift a cornering dirt car from one state to the other. If your car is twitchy in a slide, equaling out the steering arms may cure the problem.

In stock car racing, a traditional fix applied to a twitchy car is to increase the static toe-out of the front wheels, sometimes by an inch or more. The reason it's effective is not because static toe-out by itself does anything for the steering—it's that the adjustment moves the steering arms outside the ball joints and produces Ackermann geometry. The previous example which had the short left steering arm is now shown with equal length arms, but whose ends are now located outboard relative to the ball joints:

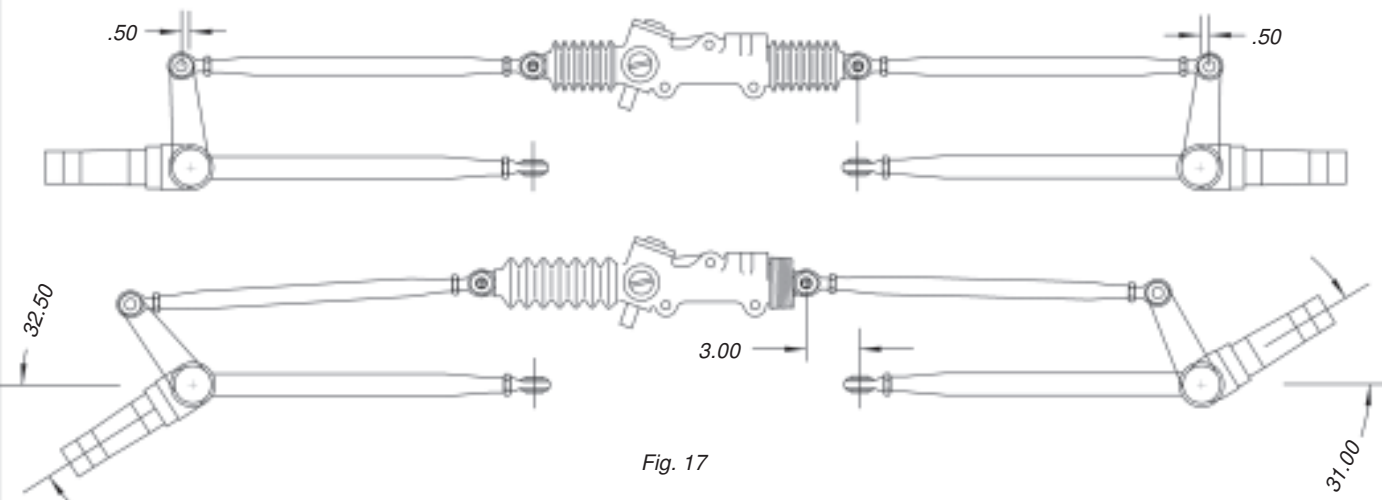

Fig. 17

The amount of Ackermann created in figure 17 by moving the steering arms .500 outboard has incidentally just about equaled that produced in one direction by the .300 shorter steering arm in figure 15. More importantly, *the steering can now be turned in both directions without the front end changing from toe-out to toe-in.*

While most of the foregoing examples have dealt mainly with initiating a left turn (or, on pavement, maintaining a left turn) there remains the question of whether positive Ackermann applies to a dirt car while in a slide and/or carrying the left front wheel.

The answer is that, regardless of the attitude of the car or the slip angle of the rear wheels, the function of the front wheels remains *to steer the car through a turn*. Since countersteering involves steering to the right relative to the car, it's easy to forget that the front wheels are still aimed so as to roll around a left turn relative to the track. In figure 18 at right, although the pavement car is being steered left and the dirt car steered right, their right front tires (which are of course the loaded tires and account for most of the steering) follow virtually identical paths. On the dirt car, the inside wheel is turned somewhat farther relative to the car's overall line, because it's being steered closer to full lock and the Ackermann spread is greater. As the left front unloads, its steering effectiveness is progressively reduced. At some point just before it leaves the ground, the tire's only remaining steering ability derives from Ackermann, which presents the tread at a slip angle and acts somewhat like a left front brake.

Once the left front is picked up, its geometry is temporarily irrelevant. However, it will touch back down at the end of the chute, and may have to do so rather suddenly. When it does, a slight leftward Ackermann scrub will ease the transition back to a four-wheel format by keeping the front end from executing a surprise right turn into the wall.

At the extreme turning angle usually present here, the *mechanical stability* of the linkage becomes as great a concern as the details of geometry. As mentioned previously, rack setback improves the push-pull alignment of the tie rods with the rack as the steering angle increases. The other useful property of rack setback is that it generates additional Ackermann. The combined effect is shown below in figure 19 (this is the same layout that is seen from underneath in figure 6):

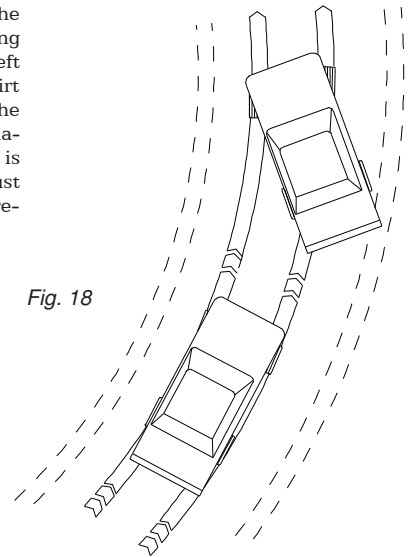

Fig. 18

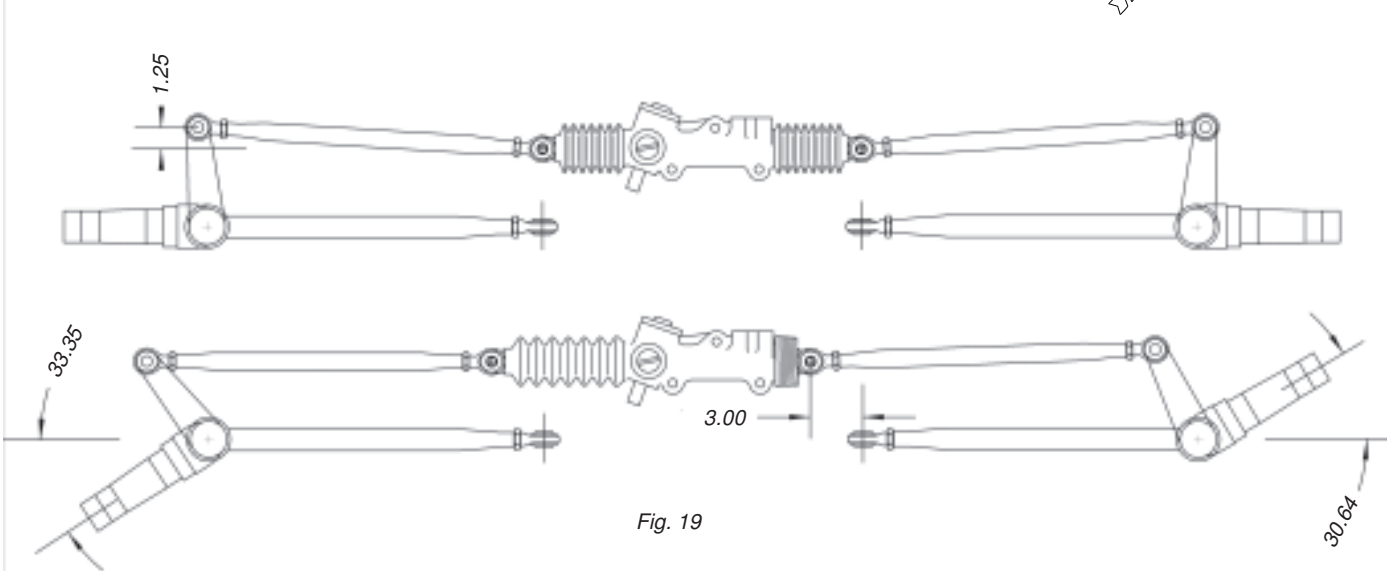

Fig. 19

While the linkage angles may not amount to much on pavement simply because the turning angle is small, it is worth looking at them from the standpoint of mechanical stability. The more direct the push and pull, the less toe change will result from deflection of the parts. It may also be possible to get enough Ackermann from rack setback to avoid tie-rod interference with the brake rotors or wheels. On dirt, it should be set back far enough to get good alignment at the maximum turning angle to the right, which is when the steering linkage is under the heaviest load.

To sum up, Ackermann geometry will make corner entry more positive on both dirt and pavement, and, on dirt, will make the car easier to control in a slide. It is entirely possible that a comparison of these diagrams with the front end layout of your car will suggest certain physical improvements. If so, they are worth doing. Getting rid of reverse Ackermann is one of the most dramatic and instantly rewarding changes you can make to a race car.

A further refinement possible on many cars is to straighten out the steering shaft routing. The steering shaft is frequently laid out as an afterthought (routed around structure, headers and so forth) and will often incorporate high u-joint angles. Excessive angularity causes nonlinear steering, which is a speeding up and slowing down of the steering ratio during rotation of the steering wheel. Depending on its relationship to the position of the driver's hands, the cycle can be unnoticeable until a certain point is reached in the turning of the wheel, whereupon an unexplainable spinout occurs, leading one to blame the tires. If your car exhibits this tendency, it may be worth examining the steering shaft layout to see if there is room for improvement (there usually is). Any increase in mechanical smoothness and efficiency that it is possible for you to make in this area will pay dividends by broadening the driver's useful range of steering input. The broader this range, the more forgiving the race car. This subject is treated in considerably greater detail in the sections on *Power Steering Tech* and *Steering Shaft Fabrication*.

8. Rack Inspection and maintenance:

Besides keeping the rack greased, it's a good idea to occasionally remove the left-side boot and wipe any clay, pebbles, etc., out of the rack teeth. Care should be taken also, when washing the race car, not to blast water and debris directly into the ends of the unit.

The rod bracket, P/N G264, should be inspected frequently to ensure that play has not developed between it and the piston rod. The flat washers used either side of the bracket, although they are high-grade material, will eventually get hammered with use. The resulting play will allow a vibration that can be felt at the steering wheel. Tighten the locknut and/or replace the washers.

With the snubber properly adjusted, a Woodward manual rack and pinion can be turned easily by hand while a twisting load is applied to the rack shaft. The snubber is an important component whose broad, flat contact on top of the rack shaft resists the tendency of offset tie rods to rotate the rack shaft while steering (which causes edge-riding of the gear teeth and binding). More noticeably, rotation allows the inner tie rod ends to rock fore and aft. As little as 3/16" of movement here can result in a toe change of over one inch out at the tire centerlines, in the same way that moving the rack rearward in the car increases the Ackermann (only in this case the effect is transient and unstable).

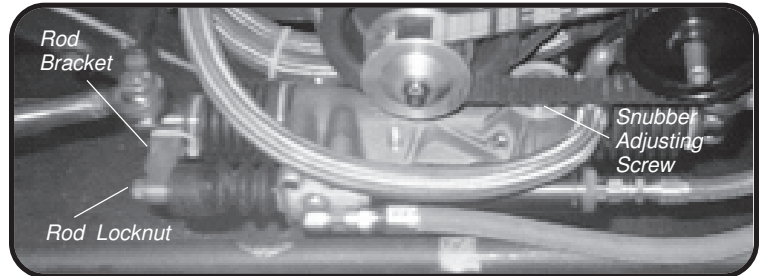

Fig. 20

On a power rack, the cylinder and rod bracket will tend to resist this twisting action, but if the cylinder is called upon to perform this function by itself, early seal wear may result. The snubber is a highly effective means of protecting the cylinder from loads other than push/pull, and should be checked periodically. To check the snubber, jack the front wheels off the ground and loosen the piston rod locknut. Grasp one of the wheels and hold it while somebody turns the steering wheel back and forth. Observe the inner tie rod end—if it rocks, insert a suitable tool into the 3/16" slot in the adjusting screw and turn it until this motion disappears. **Tight enough to prevent rocking should still allow the rack shaft to slide freely!** If you have to bind the rack in order to cure the problem, the bushings are worn out and/or your inner tie rod ends are spaced too high above the rack centerline to be mechanically sound. Either condition should be corrected at the earliest opportunity. After adjusting, remember to retighten the piston rod locknut (caution: overtightening may cause the piston rod to "walk" and put the rod seal and bushing in a bind. Just take out the end play).

NOTE: The snubber adjusting screw is kept from vibrating loose by a set screw which holds a soft plastic ball against the threads. This set screw should never be so tight that the snubber adjusting screw cannot be turned with a tool in the slot.

Fig. 21

9. How to identify the rack ratio:

An original factory installation will have the ratio stamped on the upper edge of one or both bearing caps as in fig. 21. If there are no numbers stamped on the caps, that pinion assembly will have been field installed. To ascertain its ratio, just measure the distance from one tie rod hole to some stationary object. Turn the steering wheel (or the pinion) one full revolution and remeasure; the difference is the linear travel of the rack, which is the "gear ratio" of the rack and pinion. This ratio is determined by the number of teeth on the pinion; the more teeth, the larger the pinion—and the quicker the steering. Changing the ratio in type G or H racks is a matter of replacing the pinion assembly and adjusting it to mesh with the rack teeth.

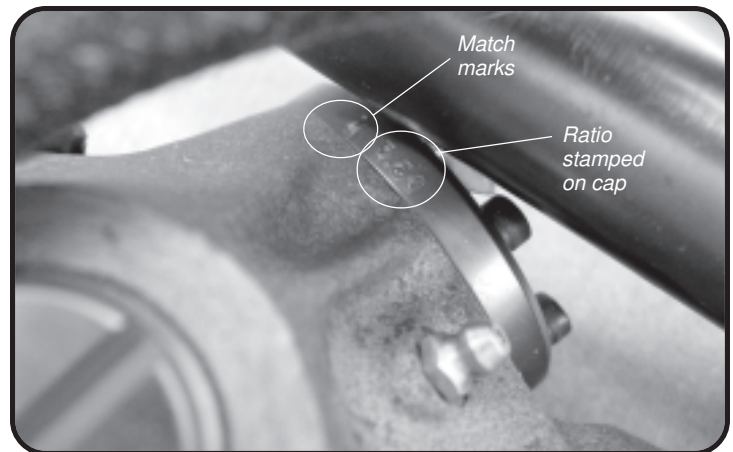

Fig. 22

9. Changing ratios (pinion assemblies):

The pinion gear and its bearings are carried in eccentric caps (see figure 22), which are indexed to different positions in order to accommodate various gear diameters and adjust them against the rack. The interchangeability of the various pinions is accomplished with pairs of eccentrics. "A" caps are ordinarily used with the 2.09, 2.36, 2.88, and 3.14 ratios, "B" caps with the 2.36 and 2.62 ratios, "C" caps with the 1.57, 1.83, 3.40, and 3.66 ratios, and "D" caps for the 3.92 ratio (note that installation of the 3.92 gear requires extra clearance to be machined inside the housing). The 4.19 and 4.45 use "D" caps in a special rack housing.

A pinion assembly originally installed at the factory will have been match-marked to the housing with small arrows stamped into the caps. These marks indicate the installed position of the original pinion only, and if the pinion is replaced the match marks will no longer apply. If you change the adjusted position, it's a good idea to stamp or scribe some new marks on the caps.

To install and adjust a pinion assembly, insert the assembly into the housing (without the small cap) as shown in the illustrated parts breakdown. Firmly press the large cap against the housing (as if it were bolted) and rotate it until the gear is tight against the rack shaft. Bolt it up as closely as possible to this position (using two bolts opposite each other). Test for backlash by turning the pinion with your fingers.

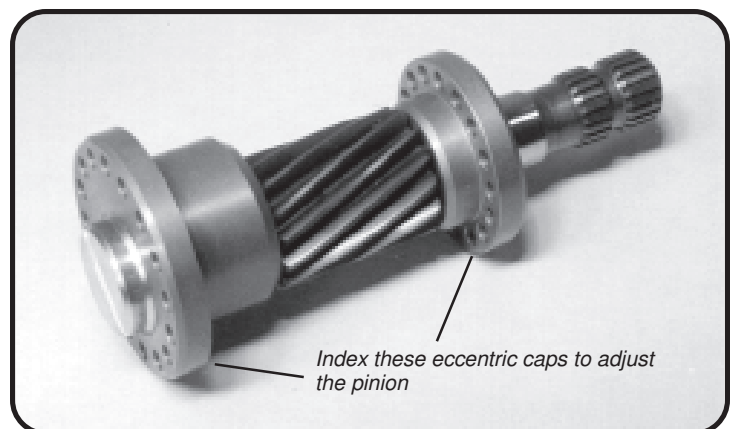

If it's too tight, back off one hole. If it's too loose, attempt to index it one hole tighter. If it will not go to the next hole, index it from the *opposite direction* (for example: change from the 3 o'clock position to the 9 o'clock position). This will tighten, or loosen, by about half a step. When it feels acceptable, install the small cap. It may be possible to rotate the small cap by as much as one bolt hole in either direction; use the position which reduces the backlash to a minimum, but make sure the pinion is not in a bind. If necessary you can hone or scrape the bushing for clearance.

The best way to tell how your adjustment will feel to the driver is to install an old u-joint or coupler on the pinion, with a piece of rod or bar stock welded to it like the spoke of a steering wheel. Turning the pinion as in fig.22 will simulate the leverage exerted by a steering wheel, and will indicate how much play will exist out at the rim.

For best operation, there should be some backlash present. *Preload should be avoided*, since it scrubs away the lubricant film; all gears last longer and operate more smoothly if they have some clearance. Test for correct backlash by moving the rack shaft in and out while keeping the pinion from turning. You should be able to feel a small amount of play with dry gear teeth. With a dial indicator the rack end play should measure .004"-.010", with slow ratios at the tight end of this range, and fast ratios at the loose end. This translates to about 1/16" at the rim of the wheel for slow steering, with up to 3/16" permissible for quick steering. This amount of play will only be noticeable with the car parked, and will generally give the best results for mechanical ease of turning.

NOTE: Unlike other power steering systems (all of which utilize street-vehicle servo components and are backlash-sensitive) **Woodward power steering is backlash-neutral and does not require pinion preload.** At system pressures over 65 PSI it will actually remove detectable backlash at the steering wheel. **There is no need to jack down on the snubber like on a street-vehicle type rack and pinion.**

10. Replacing rack bushings:

After 50 races, the factory-installed rack bushings will usually need replacement. Rebuilding the unit is a fairly easy do-it-yourself project, requiring only a honing operation as an outside service. Drive the old bushings out with a rod as in fig. 24.

Because the housing is magnesium and fairly soft, the bushings have a substantial interference fit and require some care to get started squarely in the bores. Drive them in with a hammer until they bottom, using a pilot under the hammer to prevent damage (see fig. 25).

Important: before fitting the new bushings to the rack shaft, *completely* deburr the rack shaft and teeth with a fine single-cut file.

The rack bushings are made with a special undersize ID that will clean up to a 100% bearing surface against the shaft. Fitting the new bushings is best performed by line-honing on a Sunnen machine with a 1-1/4" mandrel long enough (4 or 5 stones) to pass through both bushings and allow the work to be reciprocated. The operation is shown in fig. 26.

An experienced machinist can also fit the bushings using a piloted reamer. Whether honing or reaming, this work can be done by any shop that fits kingpins to large truck spindles. Many engine shops will have a honing mandrel of the required size. The fit should be as close as possible but should allow the greased rack shaft to slide in the bushings of its own weight when tilted. **NOTE:** Nominal size off-the-shelf bushings will *not* provide adequate bearing contact for this application. If service is not available in your area, we can handle any repairs at the factory.



Fig. 23

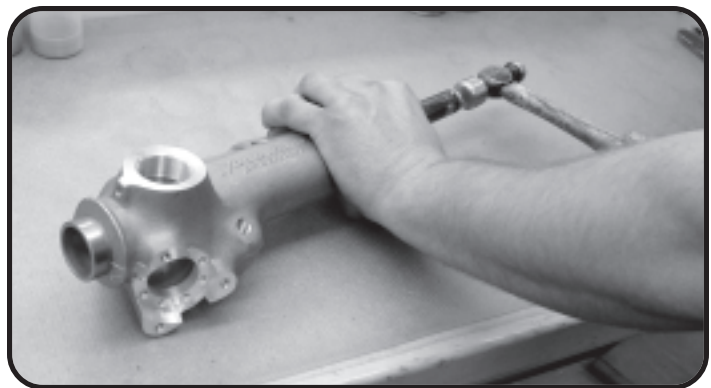

Fig. 24

Fig. 25

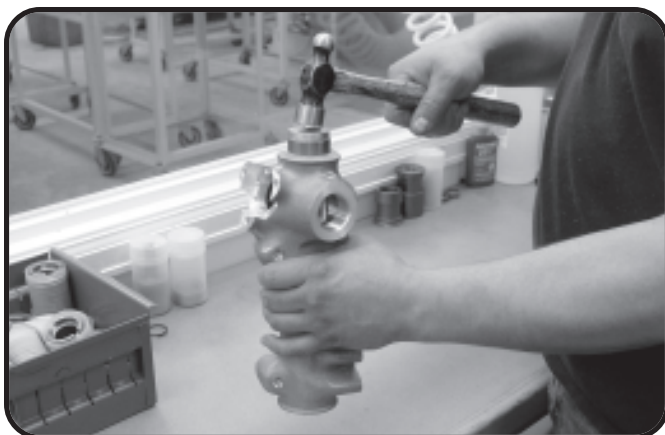
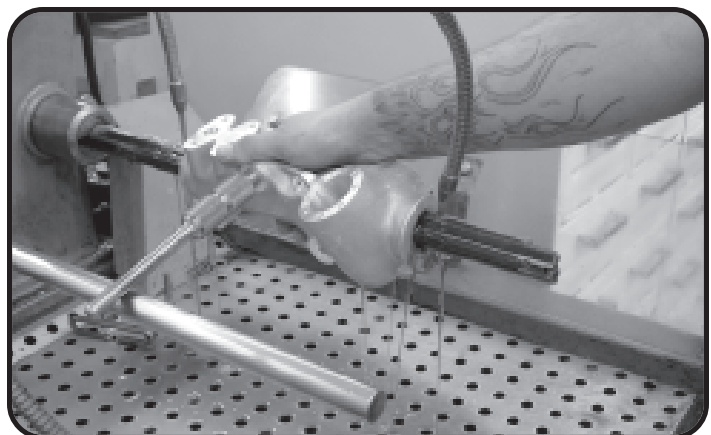

Fig. 26



11a. Steering ratios for oval track racing:

It is worth mentioning that current North American short track cars tend to be equipped with considerably quicker steering than was the case twenty-five years ago. At that time, the conventional wisdom had it that anything faster than a 16:1 Corvette worm gear was “too quick” for the driver to keep up with. In the case of the steel-bodied behemoths of the 1970s, this was at least partly true, since those cars (in addition to their high unsprung weight) had cumbersome steering linkages. These were prone to deflection because of all the rubber bushings that were used throughout front ends in those days, and were pretty sloppy by present standards. Lighter cars, coilovers, and spherical rod ends made rack and pinion steering practical for stock cars, and the *more positive linkage* provided by rack and pinion steering made quicker ratios practical. These days, it is not uncommon to find a 2.62 rack used with 5-1/2” steering arms at a one-mile, 175-mph paved track like Phoenix, while on dirt, saying the steering is too quick is about like saying your tires are too wide—in other words, *not likely*.

The case for quick steering can be summed up with the common-sense observation that it multiplies your reaction speed. The limiting factors are equally obvious, if you think about them: the degree of precision and smoothness with which you can *apply* your reactions to a steering wheel, and the relative consequences of overcorrection and/or disturbing the cornering attitude of the race car (a few degrees’ error committed on a superspeedway can be irrecoverable, whereas far greater errors committed while backing it in on some potholed bull ring, on the other hand, may be easily recoverable). Figure 27 illustrates the case for quick steering on dirt:

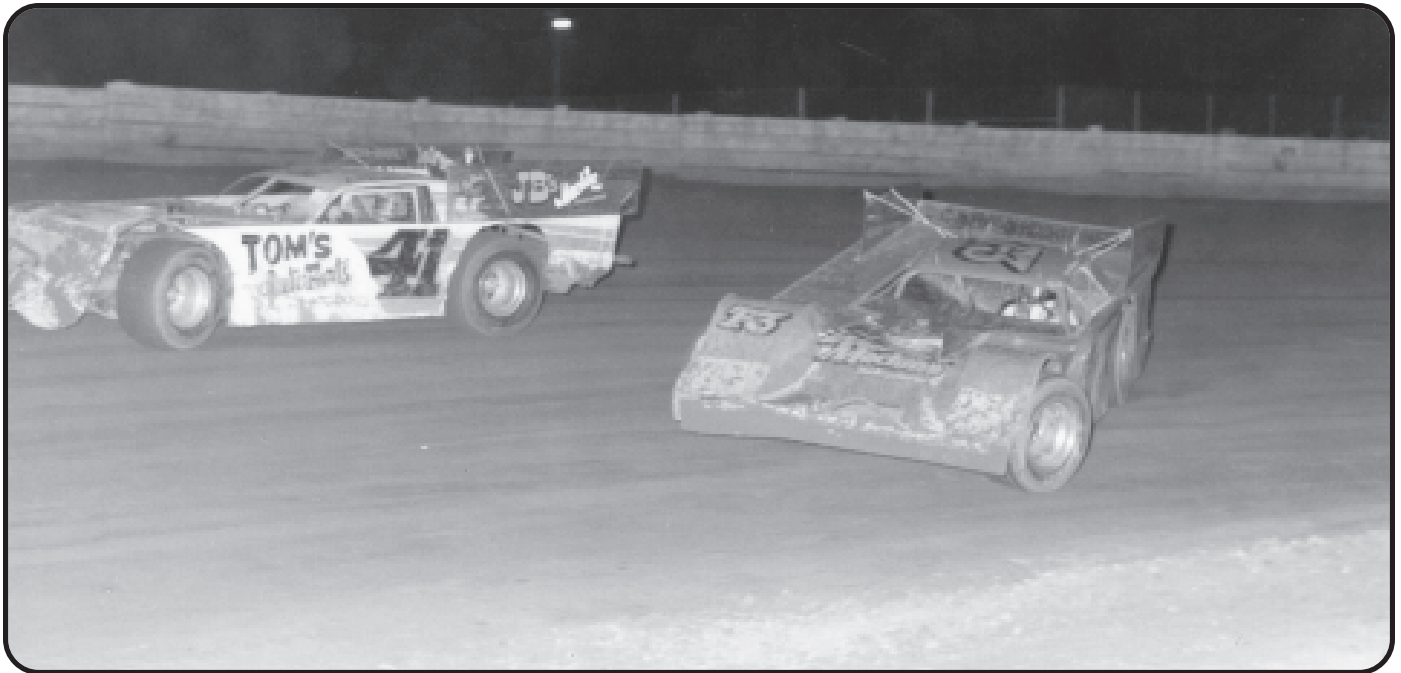

Fig. 27

In figure 27 the car with the push has steering that is simply too slow for the driver to either break the push *or* effectively change his corner entry to compensate for it. The other car has steering quick enough to enable it to be thrown in under poor handling conditions but still caught by the driver quickly and easily enough to gain position. **Note that the drivers’ hands are visible—each has one hand at almost exactly ten o’clock on the steering wheel, but in the #41 it’s the RIGHT hand whereas in the #T-3 it’s the LEFT hand!** Observe the steering angle of the front wheels relative to the hand positions. This is a 3.92 ratio rack and pinion, which in 1984 was highly experimental, but whose advantages were obvious even then.

Bear in mind that adding (or increasing) power assist *does not quicken the steering*; it only decreases the input effort. Paradoxically, however, if it is easier to turn, you may apply your muscular effort more quickly, thus making your steering feel *effectively* quicker. What is actually being quickened, of course, is the reactive capability of the driver, not the gear ratio. However, as the requirement for muscular exertion is reduced, the driver becomes able to utilize quicker steering, in a sort of complementary upward spiral which, on dirt, has led to the now widespread use of rack ratios over four inches per turn. As you may have guessed from the relatively high cost of a Woodward servo, the technology of power assist has had to be greatly refined in order to reserve useful feedback from the tire contact patch in a car with so much boost it can be turned without a steering wheel even while stationary—demonstrated in figure 28 by Brian Birkhofer, who is shown driving through the pits at East Bay with his steering wheel still on the roof.

Some dirt chassis use very short steering arms. These increase the turning angle and multiply the steering ratio. However, short arms apply less mechanical leverage at the wheels and require a higher pump pressure limit—especially if used with an ultra-quick rack. Conventional 5-1/2” arms may only need a maximum of 950 PSI from the pump, while 4-1/2” arms can require over 1400 PSI (the limit is set by a relief valve within the pump). The 855 servo valve, intended for heavier, stuck-down pavement cars, is also utilized in under-leveraged cases. Servo and pump recommendations are shown in the ratio applications chart on the next page, and a **detailed discussion of power assist begins on page 80**.

Fig. 28



11b. Steering engineering practice compared among various forms of racing:

The steering ratio practical on dirt oval tracks is dictated by the slide angle necessary to countersteer into, and most especially the *rate* of rotation of the car into a slide. The total range of movement of the driver's arms during the quickest required steering stroke must remain within the limits of muscular control; for most people this is a *maximum* arc of 150 degrees—or a movement of the left hand between eight o'clock and one o'clock. The most comfortable arc is actually closer to 90 degrees. The ideal steering ratio will result in the driver operating over this range on the race track under the majority of conditions. To some this will mean switching ratios among race tracks, although the current trend is to simply hone one's physical familiarity with the car, using one ratio and lots of seat time. The ratios used on dirt cars, without exception, require mechanically driven pumps.

On pavement oval tracks the steering ratio is more a function of the radius of the turns of the race track. The arc of movement of the driver's arms carries the same physical limitation as on dirt, with the important exception that countersteering is not employed (at least not deliberately!) and the front end is held in a left turn. The ideal steering ratio will be one wherein the driver's arms remain within the range of muscular control to the left, which for most people will mean the right hand never passing a ten o'clock position. Beyond that point, the left hand does progressively less work and the driver approaches a hand-over-hand situation, which means the car cannot be driven loose and especially cannot be caught if it spins out. Because of the very direct relationship between turn radius and hand position on pavement, it is quite common for four drivers to switch rack ratios between large and small race tracks. If you do not have that option, the safest approach is to install a ratio quick enough (and with enough power assist) *for the smallest track you race on*, so as not to have to lift your hands. Pavement oval-track applications require mechanically driven pumps, albeit of lower flow rates than on dirt.

Steering on road race courses, although the racing takes place on pavement, is a special case because of the changes of direction. In terms of steering, the exaggerated transition from left to right has more in common with dirt racing than with pavement oval racing, since the steering system must be capable of sensitive response while passing through the neutral condition and not just through a range of light to heavy loads in one direction. A further complication is the presence of both 180 MPH straightaways and short, "park it" corners on the same race track. Because of this, steering ratios for road racing have always had to be a compromise between two extremes. The most promising contemporary approach would seem to be a ratio that will handle the quickest motion requirement that will be encountered anywhere on the course (for example, a sharp S-curve executed in drift or partial adhesion mode) while keeping the chassis stabilized for high speeds via precise geometry and generous amounts of caster and trail. Positive caster added to aerodynamic downforce makes power assisted steering virtually mandatory, except in the case of very light formula cars. In the majority of cases, the fluid velocity in the steering of a road race car will be low enough to permit the use of an electric pump.

While street-vehicle steering is for the most part outside the scope of this discussion, the above road-race criteria generally apply to high-end limited-production "supercars" and one-off specials, with the added requirement that, to be streetable, a car must be easily parallel-parked. Therefore, a street supercar will typically use a lighter torsion bar in the servo than its race-trim counterpart. There is no particular limitation on steering quickness for street use, other than the driver's personal comfort level.

11c. Size of the steering wheel:

Once the ratio has been established, the actual distance your hands move can be adjusted somewhat by changing the diameter of the steering wheel. Contrary to a persistent belief, the size of the steering wheel has no influence on the ratio—90 degrees is 90 degrees, whatever its diameter—but it does determine the linear distance your arm must extend during the movement. The wheel's radius is also the input lever for the steering, but with power assist the leverage of the wheel doesn't matter. Probably the most important feature of a steering wheel is how its diameter causes your arms to align with your shoulders, and how efficiently the resulting posture utilizes your upper body musculature. It's not a substitute for having the right steering ratio, but it will help you extract the best performance from your equipment.

11d. How to determine your overall steering ratio:

The overall steering ratio (12:1, 14:1, etc.) is measurable with CAD software or by using turntables under the front wheels. Beginning with the front wheels pointed straight ahead, rotate the steering wheel one turn (360 degrees) one way, and read the turning angle of the front wheels from the turntable scales. You will have to resolve the difference between the right and left caused by Ackermann; most people read the inside wheel. If, for example, your reading is 36 degrees, dividing this into 360 gives you a quotient of 10, and thus a 10:1 overall steering ratio (if it is not possible to get a full turn out of the steering wheel, use three quarters of a turn and divide into 270). For example, with a six-inch steering arm, a result of 10:1 is roughly what you could expect with a 3.14 rack. Because rack steering involves a translation (from rotary to linear and back to rotary motion) it isn't expressed very well by an equivalent gear ratio. Also, the equivalence becomes progressively more approximate with quicker racks and shorter steering arms, and so it is common now to refer simply to **rack travel numbers**, as in the following chart.

11e. Typical applications of rack ratios:

1.57 (G, H, K, and KR racks): Very slow heavy-duty steering, mainly for superspeedways or road courses where top speeds exceed 160 mph. Almost exclusively used as manual steering. With long steering arms, the overall ratio can range down to 24:1.

1.83 (G, H, K, and KR racks): Slow steering for long paved tracks (5/8 mile and over) and high speed road courses. Usually installed as manual steering. Popular in GT classes, as this ratio closely approximates that of OEM sports car steering when used in conjunction with short steering arms.

2.02 (MR, MC, and MRC racks): In MR/MRC series power racks, used in both US and FIA GT competition, Daytona Prototypes, ALMS, and high-end street supercars using shorter steering arms. Relatively low velocity in typical installations allows this rack to be powered by an electric pump. In the lighter-duty MC manual form, this is used in formula, sports racer, drag racing, and LSR vehicles.

2.09 (G, H, K, and KR racks): Formerly the most popular ratio for manual steering pavement applications in both stock car and road racing. This was known at one time as a "16:1" rack, since when installed in a typical stock car its feel was about that of the old 16:1 Corvette manual steering box. Now used with power about half the time. Use the #855 servo valve on heavy cars, #850 on lighter cars, with KRC standard 7.2cc pump, #6 and larger output fitting. An excellent all-around street rod and kit car steering, but with steering arms over 5 inches long an electric pump may not keep up.

2.24 (MR, MC, and MRC racks): In MR/MRC series power racks, used in both US and FIA GT competition, Daytona Prototypes, ALMS, and high-end street supercars. With longer steering arms an electric pump may not keep up. In MC manual form, this is mainly used in formula and sports racer.

2.36 (G, H, K, and KR racks): Quicker steering for paved oval tracks, especially those 1/2 mile and under, and road courses. Although used with power assist in most applications, it is highly effective as manual steering, particularly when equipped with monoballs or clevis ends to reduce friction. In a typical stock car its overall ratio works out to around 14:1. Heavier cars use the #855 servo valve, lighter cars the #850, KRC standard 7.2cc pump and #7 and larger output fitting.

2.47 (MC and MRC racks): Manual steering for formula cars and sports racers. The MRC powered version has an integral cylinder and an inline (remote) servo, #845 or #850 depending on car weight and tire loading. As power-assisted steering, this ratio is a good fit for many GT class cars. An engine-driven power steering pump is recommended for this and all quicker ratios.

2.62 (G, H, K, and KR racks): In the 1980s this ratio was commonly used as manual steering on dirt late models. At approximately 12:1 overall, it still gives tolerably easy steering on dirt with common caster and camber settings, and is the best entry-level choice for manual steering limited late models. Its most common application today is on pavement oval tracks and road courses with power assist. Use the #855 servo valve with a KRC standard 7.2cc pump and #8 and larger output fitting.

2.69 (MC and MRC racks): Manual steering for formula cars and sports racers. Power assist will be required for use in heavier classes such as GT. The MRC version has an integral cylinder and an inline (remote) servo, #845 or #850 depending on car weight and tire loading.

2.88 (G, H, K, and KR racks): Quicker than average manual steering for limited late models on dirt. At about 10:1, this will require setting the car's caster and camber for minimum effort unless power assist is used. For comparison purposes, this is considerably quicker steering than any road vehicle. For power assist on pavement, use the #855 servo valve; on dirt use the #850, with a KRC 7.2cc pump and #8 and larger output fitting.

2.91 (MC and MRC racks): Quick manual steering for ultralight formula cars and sports racers. The MRC version has an integral cylinder and an inline (remote) servo, #845 or #850 depending on car weight and tire loading.

3.14 (G, H, K, and KR racks): This is about the quickest ratio usable as manual steering on a full-size race car. If so used, the positive caster must be set to street-vehicle levels (under two degrees), and the caster split reduced. Unless the car is very light, this steering is much more practical with power assist; use the #855 servo valve on pavement, #850 on dirt, with a KRC 7.2cc or 8.5cc pump and #8 and larger output fitting. If a spline drive pump setup with a slow drive ratio is used (as is now common on dirt cars) a 9.6cc pump is required for this and quicker ratios.

3.14 (MC and MRC racks): Usable as manual steering in ultralight formula cars and sports racers; most practical if used with longer steering arms. The MRC version has an integral cylinder and inline servo, #845 or #850 depending on car weight and tire loading.

3.40 (G, H, K, and KR racks): Dirt power steering. For reference, this rack ratio has been typical of GRT cars. With a Woodward servo, use the #850 servo valve with a KRC 9.6cc pump and #8 and larger output fitting. Suggested servo torsion bars for this application: 225/220/215. With anything other than a Woodward servo, use "Light" or "Extra light."

3.66 (G, H, K, and KR racks): Dirt power steering. For reference, this rack ratio has been typical of Rocket cars. Use the #850 servo valve with a KRC 9.6cc pump and #9 minimum output fitting. Servo torsion bar sizes best in this application: 225/220/215. Note: if installed on a "blue" front end, the reduced leverage of the shorter steering arms need the #855 servo valve, with the T/bar in the same range as with the #850.

3.92 (G, H, K, and KR racks): Dirt power steering. Use the #850 servo, light torsion bar (220/215) and a KRC 9.6cc pump with #10 and larger output fitting. Steering arms sharper than 5 inches may require use of the #855 as above.

4.19 (D, DH, K and KR racks): Dirt power steering. Use the #850 servo, light torsion bar (215/210) and a KRC 9.6cc pump with #11 and larger output fitting. Steering arms sharper than 5 inches require use of the #855 as above.

4.45 (D, DH, K, and KR racks): Dirt power steering. Use the #850 servo, light torsion bar (210/205) and a KRC 9.6cc pump with #12 output fitting. The iron truck pump is an even better choice. Steering arms shorter than 5 inches require use of the #855 as above.

4.71, 4.98, 5.23 (X and XH racks, not shown in this catalog): Dirt power steering. Use the #855 servo, a light torsion bar (205/200/195) and a KRC iron truck pump with the largest available output fitting.

11f. Cautions:

These servo and torsion-bar recommendations are based on field experience accumulated over a number of years, by drivers ranging from national champions to first-year rookies. When trying quick power steering for the first time, an average driver's initial reaction will often be that the steering effort is too light. Although it may seem counterintuitive, the fact is that steering in the four-inch range cannot be smoothly controlled at the same level of resistance as more "conventional" slower ratios such as 3.14 or 3.40. With quick steering, the key to success is reduced muscular effort. The arm movements used with a four-inch rack are simply too short to involve the same level of physical exertion to which many drivers are conditioned. Assist levels significantly lower than those recommended for these racks will negate the advantage of the quick steering by reducing controllability.

The fact is that much of the steering effort typical of other systems is *artificial* effort; that is, the power assist is used partially to overcome preload resistance within the rack, or is so "choked off" with a stiff servo as to be barely functional—in some cases actually requiring the driver to force fluid through the system against the pump. Users of these systems have long been under the mistaken impression that the resistance they feel is "feedback" from the front wheels. That is demonstrably not true. Tire-patch loading is actually a very small component of their effort.

While the artificial resistance has no doubt kept a few drivers from getting in over their heads, it is a needless limitation when imposed on a driver of superior talent. Elimination of the excess, wasted effort, therefore, allows a true upward leveraging of a driver's ability. Users of high-powered quick units have discovered that the tire contact patch can still be sensed through the rim of the steering wheel even at a level of boost high enough to permit turning the front wheels lock to lock with one's hand on the disconnect spline—*while parked*. This is a normal condition with an ultra-quick rack.

Pavement applications for quick steering (while less exaggerated than on dirt) follow exactly the same principle. Shorter movements are smoother when they involve less physical exertion.

Type CF/CFR exploded view

Although individual parts may vary in size and shape, the assembly sequence is the same for CF20, CF20S, CF20E, CF20SE, CF20R, CF20RS, CF20RE, CF20RSE, CF12, CF12S, CF12E, CF12SE, CF12R, CF12RS, CF12RE, CF12RSE, CF00, CF00S, CF00E, CF00SE, CF00R, CF00RS, CF00RE and CF00RSE models.

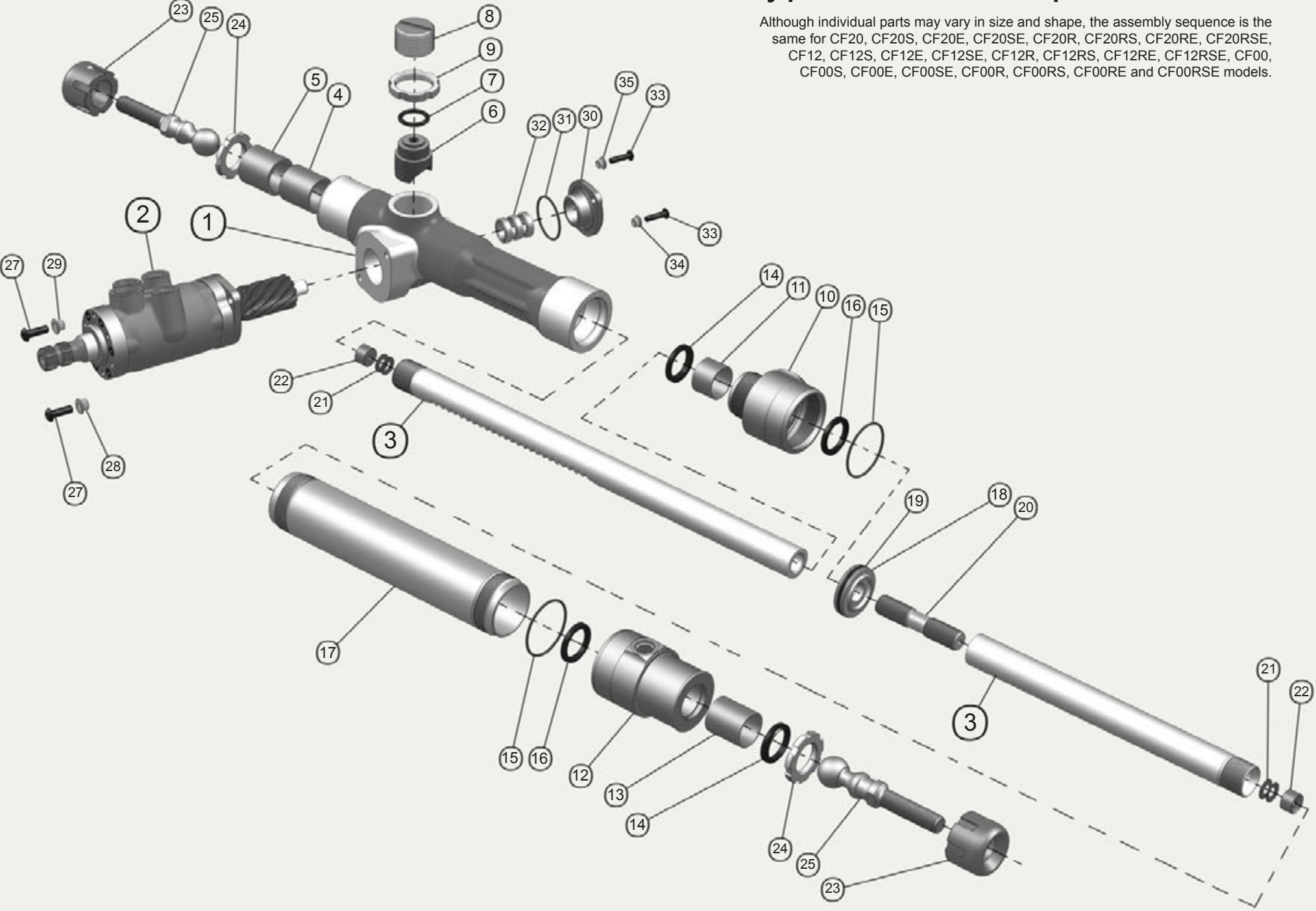

Type CF/CFR parts list

(NOTE: Variations of some of the basic part numbers shown below can run into the hundreds. Parts marked * are custom made; to duplicate these we need the original rack serial number or the model number from the CAD file.)

Dwg no.	Part no.	Description	Dwg no.	Part no.	Description
1	CF20-100 CF12-100 CF00-100 CFR20-100 CFR12-100 CFR00-100	Housing* <i>These basic castings are specifically machined for one of seven individual steering ratios as well as other model variations. The original rack serial number or the model number from the CAD file is needed to duplicate a housing.</i>	16	CF159	Loaded lip seal
2	CF800 CF900	Servo/pinion assembly* (refer to servo exploded view) <i>Any valve profile is available in any CF servo. However, the pinion (number of teeth, helix angle and hand) will only fit the corresponding rack housing.</i>	17	CF160 CF160X	Cylinder tube for 1.63 piston Cylinder tube for 1.75 piston <i>The length of the tube is specific to the rack serial number or the model number from the CAD file.</i>
3	CF200A & B	Rackshaft* <i>The length, the location of the piston, and the number and location of the rack teeth are specific to the serial number or the model number from the CAD file.</i>	18	CF171 CF171X	Piston, 1.63 diameter Piston, 1.75 diameter
4	CF101A	Rack bushing, 1 x 1.25OD x 1.25L	19	CF172 CF172X	O-ring for 1.63 piston O-ring for 1.75 piston
5	CF101B	Rack bushing, 1 x 1.312OD x 1.25L	20	CF250	Rack stud
6	CF102	Snubber	21	CF403 CF404	Belleville spring Belleville spring
7	CF103	Snubber O-ring	22	CF405	Preloader
8	CF104	Snubber adjusting screw	23	CF410	Monoball adjuster
9	CF105	Snubber lock nut	24	CF411	Monoball lock nut
10	CF151 CF151X	Cylinder adapter for 1.63 piston Cylinder adapter for 1.75 piston	25	CF412	Monoball stud
11	CF101C	Rack bushing 1 x 1.125OD x .75L	27	NPN	Servo mounting screws, 1/4-20 x 3/4 Torx IP27 drive (2)
12	CF151B CF151BX	Cylinder end for 1.63 piston Cylinder end for 1.75 piston	28	CF155A	Eccentric bushing for 1/4 screw
13	CF101D	Rack bushing 1 x 1.125OD x 1.25L	29	CF155B	Concentric bushing for 1/4 screw
14	CF157	Rod wiper	30	CF154	Pinion bearing flange
15	CF158 CF158X	O-ring for CF151 and 151B O-ring for CF151X and 151BX	31	CF152	Flange O-ring
			32	CF331	Pinion radial ball bearings (3)
			33	NPN	Pinion flange screws, #10-24 x 3/4 Torx IP25 drive (2)
			34	CF156A	Eccentric bushing, major, for #10 screw
			35	CF156B	Eccentric bushing, minor, for #10 screw

Type GE and HE Rack and Pinion exploded view

(basic mechanical parts used on both manual and power steering racks)

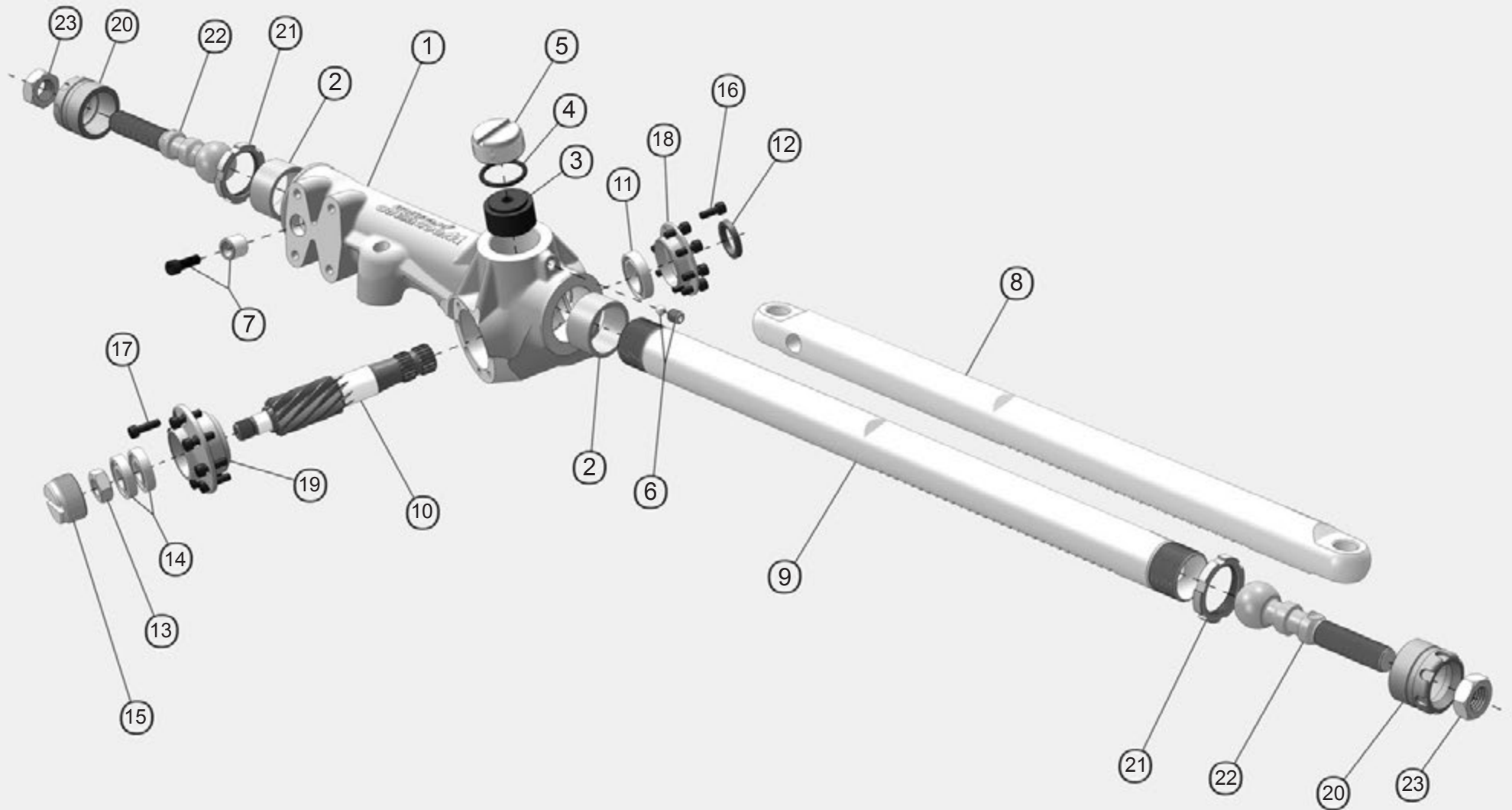

Type GE/HE parts list (basic mechanical parts used on both manual and power steering rack)

Dwg no.	Part no.	Description
1	GE100-262	Housing for GE308, 309 and 310 pinions
	GE100-288	Housing for GE311 pinion
	GE100-314	Housing for GE312 pinion
	GE100-340	Housing for GE313 pinion
	GE100-366	Housing for GE314 pinion
	GE100-392	Housing for GE315 pinion
	GE100-419	Housing for GE316 pinion
	GE100-445	Housing for GE317 pinion
	HE100-262	Housing for GE308, 309 and 310 pinions
	HE100-288	Housing for GE311 pinion
	HE100-314	Housing for GE312 pinion
	HE100-340	Housing for GE313 pinion
	HE100-366	Housing for GE314 pinion
	HE100-392	Housing for GE315 pinion
HE100-419	Housing for GE316 pinion	
HE100-445	Housing for GE317 pinion	
<i>(Note: All housings include GE101, 102, 103, 104 and 105 and are pre-honed for the rackshaft. Type HE housings also include VHE584 and VH201 shown elsewhere)</i>		
2	GE101	Rack bushing (2 required)
3	GE102	Snubber
4	GE103	Snubber O-ring
5	GE104	Snubber adjusting screw
6	GE105	Set screw and plastic ball
	GE106	Zerk [grease] fitting (not shown)
7	GE107	Dowel, 9/16 x 1/2 with 1/4-20 x 1/2 socket screw
	GE108	Dowel, 9/16 x 5/8 with 1/4-20 x 5/8 socket screw
8	GE230-8-1725	Standard rackshaft for GE308 pinion, 17.25 centers
	GE230-9-1725	Standard rackshaft for GE309 pinion, 17.25 centers
	GE230-10-1725	Standard rackshaft GE310-up pinions, 17.25 centers
	GE230-8-1825	Standard rackshaft for GE308 pinion, 18.25 centers
	GE230-9-1825	Standard rackshaft for GE309 pinion, 18.25 centers
	GE230-10-1825	Standard rackshaft for GE310-up pinions, 18.25 centers
	GE230-10-1925	Standard rackshaft for GE310-up pinions, 19.25 centers
	GE230-10-1975	Standard rackshaft for GE310-up pinions, 19.75 centers

Dwg no.	Part no.	Description
9	GEM230-8-1725	Monoball rackshaft for GE308 pinion, 17.25 centers
	GEM230-9-1725	Monoball rackshaft for GE309 pinion, 17.25 centers
	GEM230-10-1725	Monoball rackshaft for GE310-up pinion, 17.25 centers
	GEM230-8-1825	Monoball rackshaft for GE308 pinion, 18.25 centers
	GEM230-9-1825	Monoball rackshaft for GE309 pinion, 18.25 centers
	GEM230-10-1825	Monoball rackshaft for GE310-up pinion, 18.25 centers

(Not shown):

	GEC230-10-1825	Slotted-clevis rackshaft for GE310-up, 18.25 centers
	GEC230-10-1925	Slotted-clevis rackshaft for GE310-up, 19.25 centers
	GEC230-10-1975	Slotted-clevis rackshaft for GE310-up, 19.75 centers

10	GE308 (HE308)	Pinion, 8T, ratio 2.09 inches/turn
	GE309 (HE309)	Pinion, 9T, ratio 2.36 inches/turn
	GE310 (HE310)	Pinion, 10T, ratio 2.62 inches/turn
	GE311 (HE311)	Pinion, 11T, ratio 2.88 inches/turn
	GE312 (HE312)	Pinion, 12T, ratio 3.14 inches/turn
	GE313 (HE313)	Pinion, 13T, ratio 3.40 inches/turn
	GE314 (HE314)	Pinion, 14T, ratio 3.66 inches/turn
	GE315 (HE315)	Pinion, 15T, ratio 3.92 inches/turn
	GE316 (HE316)	Pinion, 16T, ratio 4.19 inches/turn
	GE317 (HE317)	Pinion, 17T, ratio 4.45 inches/turn

(Note: HE pinions have a flat on the spline but are otherwise identical to GE)

11	GE321	Pinion radial bearing
12	GE323	Pinion seal
13	GE331	Pinion locknut
14	GE340	Pinion thrust bearing (pair)
15	GE341	Bearing retainer plug
16	GE350	#10-24 x 1/2 socket head cap screw (8)
17	GE351	#10-24 x 5/8 socket head cap screw (8)
18	GE400	Small eccentric bearing carrier
19	GE500	Large eccentric bearing carrier
20	M510	Monoball adjusting nut
21	M511	Monoball locking nut
22	M512	Ball stud
23	No p/n	5/8-18 UNF tie rod jam nut

Type MR exploded view

Note that MR steering racks are highly individualized; the cylinder assembly may occupy one end of the rack, or it may be located inboard. In both cases the cylinder halves are assembled around the piston and the rack/cylinder assembly tested as a unit. Although the individual parts may vary in size and shape, the assembly sequence is the same for all configurations.
Refer to the illustrated assembly instructions.

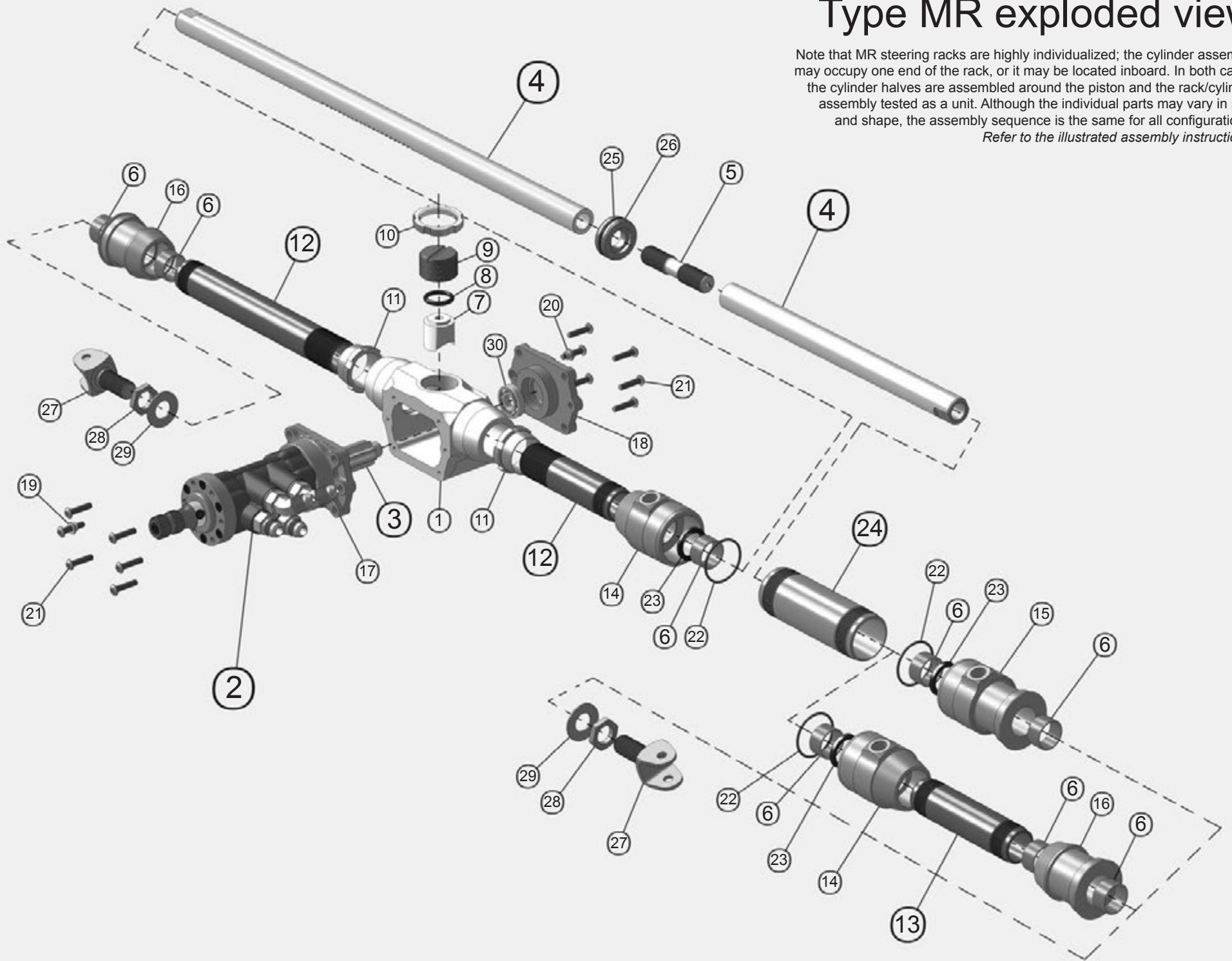

Type MR parts list

(NOTE: Variations of some of the basic part numbers shown below can run into the hundreds. Parts marked * are custom made; to duplicate these we need the original rack serial number or the model number from the CAD file.)

Dwg no.	Part no.	Description	Dwg no.	Part no.	Description
1	MR100	Housing	16	MR152	Tube end
	MR100B	Housing, offset*			
2,3	MR800	Servo/pinion assembly* (refer to servo exploded view)	17	MR153	Servo mounting flange
	MR900	<i>Any valve profile is available in any MR servo. However, the pinion (number of teeth) matches the rackshaft. To change the gear ratio requires both parts.</i>	18	MR154	Pinion bearing flange
4	CF200A & B	Rackshaft* <i>The length, the location of the piston, the number and location of the rack teeth and the ratio are specific to the serial number or the model number from the CAD file.</i>	19	MR155	Long eccentric bushing
5	MR250	Rack stud	20	MR156	Short eccentric bushing
6	MR101A	Rack bushing, 7/8 x 1OD x .5L (5 or 6 depending on the model)	21	-	Button head cap screw, #10-24 x 3/4 Torx IP25 drive (12)
7	MR102	Snubber	22	MR158	O-ring for MR151 and 151B
8	MR103	Snubber O-ring		MR158X	O-ring for MR151X and 151BX
9	MR104	Snubber adjusting screw	23	MR159	Loaded lip seal
10	MR105	Snubber lock nut	24	MR160	Cylinder tube for 1.38 piston*
11	MR111	Housing tube lock nut (1 or 2 depending on the model)		MR160X	Cylinder tube for 1.50 piston*
12	MR140	Inner housing tube* (1 or 2 depending on the model) <i>The length of these tubes is specific to the serial number or the model number from the CAD file.</i>			<i>The length of the tube is specific to the rack serial number or the model number from the CAD file.</i>
13	MR141	Outer housing tube* <i>The length of this tube, if used, is specific to the serial number or the model number from the CAD file</i>	25	MR171	Piston, 1.38 diameter
14	MR151	Cylinder adapter for 1.63 piston		MR171X	Piston, 1.50 diameter
	MR151X	Cylinder adapter for 1.75 piston	26	MR172	O-ring for 1.38 piston
15	MR151B	Cylinder end for 1.63 piston		MR172X	O-ring for 1.50 piston
	MR151BX	Cylinder end for 1.75 piston	27	MR412	Clevis for 1/4 high-misalignment spherical rod end
				MR413	Clevis for 5/6 high-misalignment spherical rod end or 8mm rod end with side shims
			28	MR415	5/8-18 thin jam nut
			29	-	5/8 SAE flat washer
			30	MR340	Pinion radial ball bearing