



-power in control



## APPLICATION NOTES



## RUDDER INDICATOR SYSTEMS Using DEIF angle transmitters and indicators



DEIF A/S · Frisenborgvej 33 · DK-7800 Skive  
Tel.: +45 9614 9614 · Fax: +45 9614 9615  
info@deif.com · www.deif.com

Document no.: 4189350085A

---

**Table of contents**

<b>GENERAL INFORMATION .....</b>	<b>4</b>
WARNINGS, LEGAL INFORMATION AND SAFETY .....	4
LEGAL INFORMATION AND DISCLAIMER .....	4
DISCLAIMER .....	4
SAFETY ISSUES .....	4
ELECTROSTATIC DISCHARGE AWARENESS .....	4
FACTORY SETTINGS .....	4
<b>ABOUT THIS APPLICATION NOTE .....</b>	<b>5</b>
GENERAL PURPOSE .....	5
INTENDED USERS .....	5
CONTENTS/OVERALL STRUCTURE .....	5
<b>DATA SHEETS AND OTHER DOCUMENTS .....</b>	<b>6</b>
<b>PRODUCT INSTALLATION DETAILS .....</b>	<b>7</b>
XL, BW, BRW INDICATORS (ANALOGUE AND CAN) .....	7
TRI-2 PANORAMA INDICATOR (ANALOGUE AND CAN) .....	10
XDI DISPLAY BASED INDICATOR (ANALOGUE AND CAN) .....	11
XDI CONNECTIONS ON MAIN UNIT .....	12
AX1 ANALOGUE EXTENSION MODULE CONNECTIONS .....	12
NX1 NMEA OUTPUT MODULE CONNECTIONS .....	13
TDG-210DG ANALOGUE INSULATION AMPLIFIER / SIGNAL CONVERTER .....	14
RTA/RTC AZIMUTH/RUDDER ANGLE TRANSMITTERS .....	15
<b>SYSTEM APPLICATIONS .....</b>	<b>19</b>
SYSTEM APPLICATION 1 – TRADITIONAL CURRENT LOOP 4-20 mA .....	19
SYSTEM APPLICATION 2 – TRADITIONAL +/-10 V SYSTEM .....	21
SYSTEM APPLICATION 3 – COMBINED 4-20 mA AND CANOPEN SYSTEM .....	23
SYSTEM APPLICATION 4 – FULL CANOPEN SYSTEM 1 .....	36
SYSTEM APPLICATION 5 – 3-WIRE RUDDER INDICATOR SYSTEM (NOT MED) .....	61
<b>APPENDIX 1 - XDI SETUP WIZARD .....</b>	<b>69</b>
XDI SETUP DURING INSTALLATION .....	69
EDIT THE INDICATOR HEADLINE .....	71
<b>APPENDIX 2 – ANGLE TRANSMITTER LOAD CALCULATIONS .....</b>	<b>74</b>
CALCULATING A 4-20 mA CURRENT LOOP SYSTEM .....	74
VOLTAGE DROP CALCULATION IN A 4-20 mA SYSTEM .....	74
LOAD CURRENT CALCULATION IN A VOLTAGE DRIVEN SYSTEM .....	76
CURRENT CALCULATION .....	77
<b>APPENDIX 3 - EXTERNAL DIMMING .....</b>	<b>78</b>
DIMMING FROM EXTERNAL PUSH-BUTTONS .....	78
DIMMING FROM EXTERNAL POTENTIOMETER (AX1) .....	78
DIMMING FROM ANALOGUE VOLTAGE INPUT (AX1) .....	79
XL DIMMING .....	79
BW 144 / 192, BRW-2 AND TRI-2 DIMMING .....	79
<b>APPENDIX 4 – STANDARD RUDDER INDICATORS .....</b>	<b>80</b>
XDI RUDDER INDICATOR LIBRARIES .....	80
XL, BW, BRW-2 OR TRI-2 STANDARD RUDDER INDICATOR SCALES .....	80
<b>APPENDIX 5: XDI DISABLING COMMANDED RUDDER .....</b>	<b>81</b>
<b>APPENDIX 6 - INSTALLING A CAN BUS SYSTEM .....</b>	<b>84</b>

XDI CAN BUS PORTS .....	84
CAN BUS SYSTEM WIRING .....	84
CAN BACKBONE AND TERMINATION.....	84
SHIELDING AND GROUNDING OF THE CAN BUS CABLES .....	86
SPECIAL ANALOGUE TO CAN CONFIGURATION .....	86

**About This document**

This application note replaces:

- Application notes Rudder Angle Indicator system 4-20 mA current loop 4189350047
- Application notes Rudder Angle Indicator system -10...0...10 V voltage input 4189350048

---

## General information

---

### Warnings, legal information and safety

#### Notes

Throughout this document, a number of notes with helpful user information will be presented. To ensure that these are noticed, they will be highlighted as follows in order to separate them from the general text.

#### Notes



**The notes provide general information which will be helpful for the reader to bear in mind.**

#### Legal information and disclaimer

DEIF takes no responsibility for installation or operation of the product. If there is any doubt about how to install or operate the product, the company responsible for the installation or the operation must be contacted.

**The units are not to be opened by unauthorised personnel. If opened anyway, the warranty will be lost.**

#### Disclaimer

DEIF A/S reserves the right to change any of the contents of this document without prior notice.

The English version of this document always contains the most recent and up-to-date information about the product. DEIF does not take responsibility for the accuracy of translations, and translations might not be updated at the same time as the English document. If there is a discrepancy, the English version prevails.

#### Safety issues

Installing and operating the product may imply work with dangerous currents and voltages. Therefore, the installation should only be carried out by authorised personnel who understand the risks involved in working with live electrical equipment.

#### Electrostatic discharge awareness

Sufficient care must be taken to protect the terminals against static discharges during the installation. Once the unit is installed and connected, these precautions are no longer necessary.

#### Factory settings

The product is delivered from factory with certain factory settings. These are based on average values and are not necessarily the correct settings for matching the product in question. Precautions must be taken to check the settings before running the product.

---

## About this application note

---

### General purpose

This document includes a technical description of the rudder indicator systems shown in the DEIF brochure "RUDDER ANGLE INDICATOR SYSTEMS". It shows how DEIF's illuminated rudder indicators and rudder angle transmitters can be used in different combinations to form a rudder indicator system. Most systems described in this document complies with the European Marine Equipment Directive (MED), the components to form the system is tested as a system and are listed in the MED certificate. You will find the certificate on [www.deif.com](http://www.deif.com), open the product webpage for any of the used indicators or rudder transmitters and look in: Documentation, Approvals/Certifications where you will find the certificate: DNV GL RAI (B) MEDB00003AN UK. The products used are individually wheel-marked.

The Rudder Angle Indication system provides continuous indication of the actual rudder position of the steering gear. The indication system shown is for a single steering gear, but it can easily be duplicated for applications with double rudder systems.

The main components are:

- Panel-mounted indicators, type XL72/96/144/192
- Panorama indicator, type TRI-2
- Bridge wing indicators, type BW144/192
- Bridge wing indicator, type BRW-2
- Flexible display indicators, type XDi 96D/144D/192D
- Rudder angle transmitter, type RTA602 (4-20 mA) or RTC 300 or 600 (CANopen)
- Rudder transmitter accessories for mechanical connection to the rudder
- Analogue signal converter, type TDG-210DG

The example shown is one of many possible combinations of products, inputs, scales and wiring. Depending on the actual needs, this might inspire to make the best use of the DEIF product range for the actual application.

### Intended users

The document is mainly intended for the person responsible for the technical designing of indicator systems for ships. In most cases, this would be a system integrator or bridge panel designer. Naturally, other users might also find useful information in this document.

It is important to read the user and installation documentation in addition to the information you get in this application note.

### Contents/overall structure

The document is divided into chapters, and in order to make the structure of the document simple and easy to use, each chapter will begin from the top of a new page.

---

## **Data sheets and other documents**

From the DEIF website [www.deif.com](http://www.deif.com), additional documentation such as data sheets, installation manuals, type approval certificates and additional application notes are available for download, this document included.

You can also find the brochure: "RUDDER ANGLE INDICATOR SYSTEMS" on the webpage under Publications / Rudder Angle.

Further information about the products, used in the different rudder indicator systems presented in this application note, can be found in the following documents:

XL, BW and BRW:

- Illuminated indicators data sheet 4921250057 UK
- Illuminated indicators, standard scale designs 4921290030 UK
- Illuminated indicators CAN specification 4189350023 UK
- Illuminated indicators user manual 4189350024 UK

TRI-2:

- TRI-2 data sheet 4921250066 UK
- TRI-2, packing instructions 8888888888TRI UK
- TRI-2 user's manual 4189350053 UK
- TRI-2 quick guide 4189350042 UK

XDi indicators:

- XDi data sheet 4921250067 UK
- XDi-Standard virtual indicator library 4189350067 UK
- XDi designer's handbook 4189350049 UK
- XDi-net CANopen reference manual 4189350066 UK.

TDG-210:

- TDG-210DG data sheet 4921220011 UK
- TDG-210DG-2 installation instructions 1159040018 UK
- Mounting instructions for switchboard instruments 4189320059 UK

RTA / RTC angle transmitters:

- RTA 602 data sheet 4921250068 UK
- RTA 602 installation instructions 4189350070 UK
- RTA 602 quick guide 4189350051 UK
- RTC 300\_RTC 600 data sheet 4921250069 UK
- RTC 300\_RTC 600 installation instructions 4189350071 UK
- RTC 300-600 quick guide 4189350052 UK

Approvals

Find the latest class and MED approvals on [www.deif.com](http://www.deif.com) on the documentation page for each product and in the folder: "+Approvals/Certifications".

## **Product installation details**

### **XL, BW, BRW indicators (Analogue and CAN)**

XL is a traditional analogue indicator with a mechanical pointer. The pointer is controlled by a microprocessor using our patented x-coil technology which gives a high accuracy (class 0.5). To obtain good visibility in all light conditions the XL scale is illuminated by a dimmable LED backlight. In designs with black scale base colour the pointer is also illuminated.

Dimming is controlled by a potentiometer and requires that XL is supplied with a dimming voltage up to 30 V DC.

The interface for the XL can be ordered with a wide range of input options. The analogue interface is available with both single and dual inputs. Using the dual input function enables XL to take input from a SIN/COS angle sensor.

The analogue input is both supporting current and voltage and covers a large input range. This includes the commonly use current of 4-20 mA or voltage of +/- 10 V.

See the data sheet for a full overview of available input ranges.

### **CAN interface**

XL can also be ordered with CAN bus interface. The CAN interface exist in two versions, sCAN and Dual CAN.

sCAN is a single CAN line connected directly to a CAN transmitter. The receiving node ID must be known when ordering an XL with an sCAN interface.

Dual CAN has full redundancy from two galvanic separated CAN lines. This version is typically used in systems where a CAN master controls different indicators.

### **Connections**

The input connections depend on the version of the indicator (analogue or CAN). Detailed descriptions of the input connections are described in the sections below.

## Analogue input connections

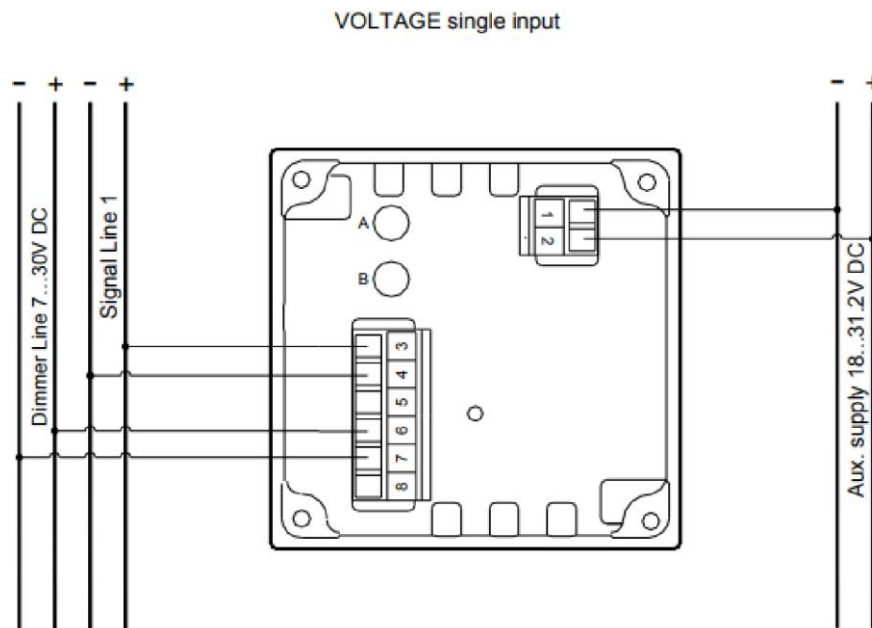

Pin number	Function		Note
1	Supply voltage	0 V	Max. consumption: 150 mA
2		24 V	
3	Analogue input	Input 1 (SIN)	Input 1 and GND used for single input At 4 to 20 mA, input 1 is CW and input 2 CCW <b>Note: GND is mutual for input 1 and input 2</b>
4		GND	
5		Input 2 (COS)	
6	Illumination	Illumination+	Dimmer input. Dimmer range 7 to 30 V DC Consumption max 30 mA
7		GND	
8		NC	
A	Analogue adjustment	Max. adjustment	Max and zero adjustment, sealed by label
B		Zero adjustment	

## CAN input connections

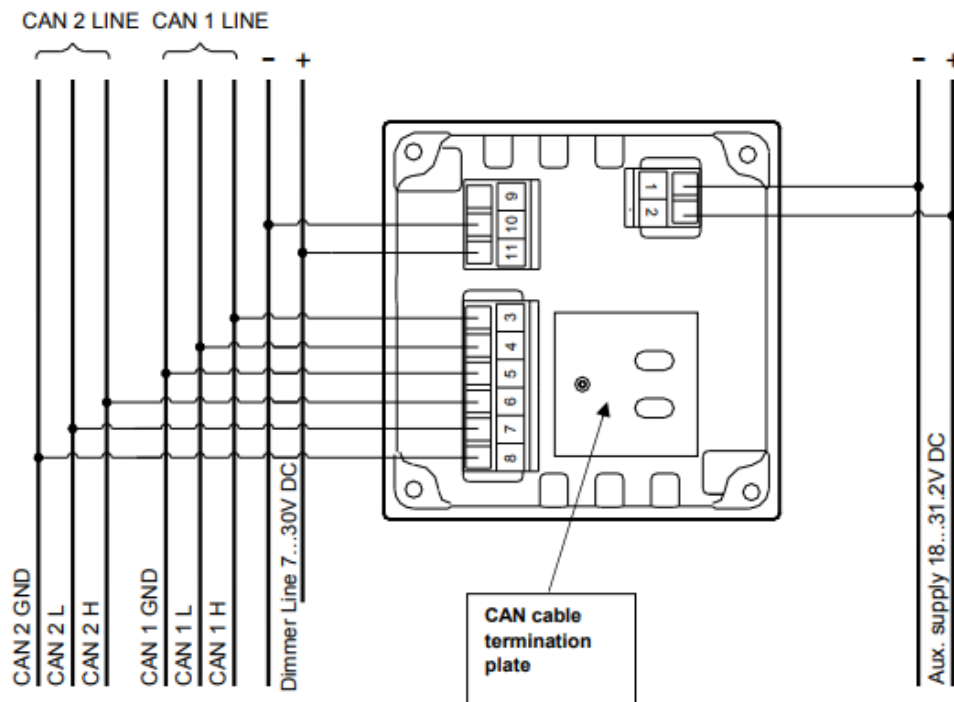

Pin number	Function		Note
1	Supply voltage	0 V	Max. consumption: 150 mA
2		24 V	
3	CAN connection	CAN 1 H input	CAN 1 line
4		CAN 1 L input	
5		CAN 1 GND	
6	CAN connection	CAN 2 H input	CAN 2 line
7		CAN 2 L input	
8		CAN 2 GND	
9	Illumination analogue dimmer	NC	Dimmer input. Dimmer range 7 to 30 V <sub>DC</sub> Consumption max. 30 mA
10		Illumination GND	
11		Illumination +	

### Outdoor version

BRW-2 is the preferred indicator for the outdoor use when the white scale it uses. With the built-in dimmer on the front the dimming can easily be controlled. BRW-2 has 3 large PG21 glands for cable mounting.

BW with pivot foot is ideal for indoor mounting, but it can also be used for outdoor mounting. Pay special attention to the cable size when using the BW with pivot foot for outdoor mounting. BW144 uses PG9 for 5 to 8mm cables and BW192 uses PG16 cable glands for 8 to 14mm cables.

When placing the BW outside it is recommended to use the white scale base for the indicators.

## TRI-2 Panorama indicator (Analogue and CAN)

The TRI-2 panorama indicators are intended for ceiling mounting and should be placed so it can be seen from all positions on the bridge. The three large curved scales of the TRI-2 are made so the rudder position can be seen from a 250° angle and a distance of up to 5 meters.

The analogue TRI-2 version can be ordered with either current or voltage input.

TRI-2 CAN is available with either Dual CAN or sCAN protocol.



The sCAN version is used for the rudder applications in this application note.

### Connections

The input connections depend on the version of the indicator (analogue or CAN). Detailed descriptions of the input connections are described in the sections below.

#### Analogue input connections

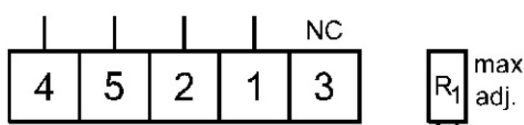

Pay attention to the order of the terminal numbering.

Pin number	Function		Note
1	Analogue input	Input -	Voltage or mA input, often ordered as +/-10 V or 4-20 mA
2		Input +	
3		No connection	
4	Illumination	+ 24 V DC	Consumption max. 150 mA
5		0 V DC	

#### CAN input connections

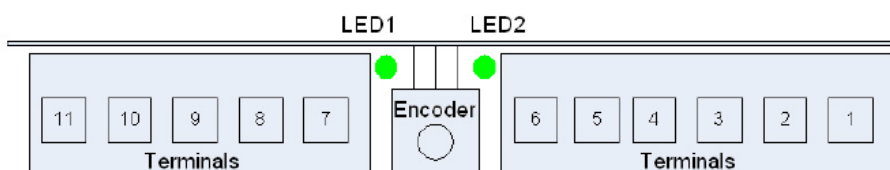

Pin number	Function		Note
1	Supply voltage	+ 24 V DC	Consumption max. 150 mA
2		0 V DC	
3	CAN connection	CAN 2 H input	CAN 2 line
4		CAN 2 L input	
5		CAN 2 GND	
6		No Connection	
7	CAN connection	CAN 1 H input	CAN 1 line*
8		CAN 1 L input	
9		CAN 1 GND	
10	Illumination analogue dimmer	Dimmer wiper	Dimmer controlled via 1kΩ 2W potentiometer
11		Dimmer ref.	

\*Note: Only CAN 1 has a switch to activate the internal termination resistor.

### XDi display based indicator (Analogue and CAN)

In the sections that follow, the term XDi represents any of the three XDi sizes: XDi 96, XDi 144 or XDi 192.

XDi with the preinstalled DEIF standard rudder indicator library has performance class Dual.

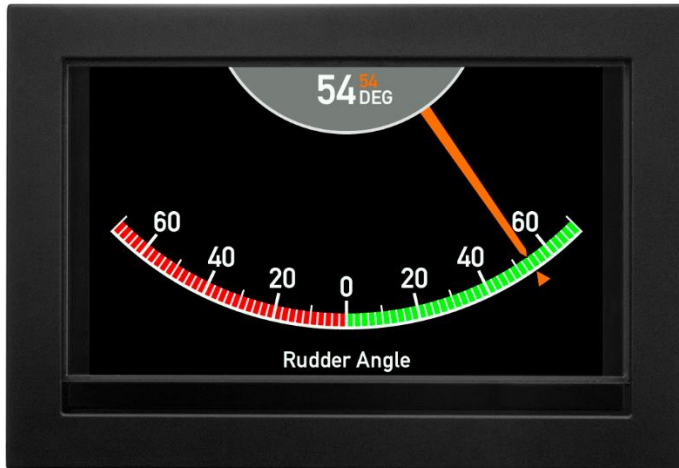

All the XDi rudder indicators can show both the actual rudder angle and the commanded rudder position (or the rudder setpoint). If commanded data is not available, the commanded rudder presentation must be disabled from the XDi installation menu.

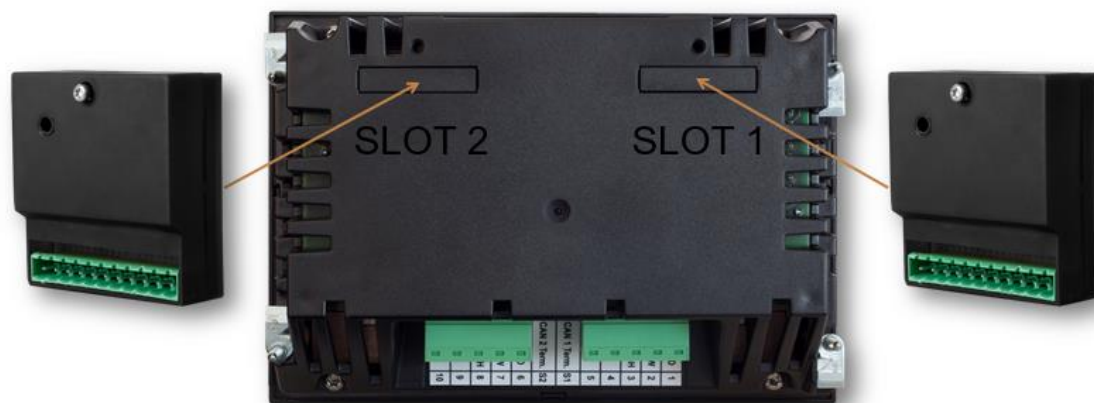

The XDi base unit has two CAN bus interfaces. Therefore, the actual rudder angle and commanded rudder angle can be received directly through one of the CAN bus interfaces.

This means that the rudder angle value can be received directly as serial data via CANopen. The angle value can be sent in a standard CANopen TPDO or RPDO or using the XDi-net data format.

XDi-net is an extension on top of CANopen, making it easy to use the CAN bus for high accuracy data sharing in a hybrid analogue/CAN-system. Examples of a hybrid analogue/CAN-systems are shown in some of the application examples.

To receive inputs from an analogue rudder transmitter, the XDi rudder indicator must have an AX1 analogue extension module installed. The AX1 module has two configurable analogue input ports. Each configurable port can be configured as a current input or a voltage input. There is also a third analogue voltage input that is often used as a dimmer input.

The input current or voltage is scaled to the actual rudder angle value controlling the pointer on

the XDi display. This value can be shared through CAN bus.

The virtual rudder indicators in the standard rudder library supports CAN data sharing using the XDi-net plug & play protocol and/or transmitting the angle value in a standard CANopen TPDO.

The use of CAN bus can increase the overall system accuracy and make system calibration easier.

See Appendix 1 for more information about setting up the XDi during installation. Appendix 1 contains detailed descriptions to select the right setup for dimmer, the selection of the virtual indicator and input setup.

### XDi connections on main unit

Type	Terminal no.	Signal	Marking	Remark
Connector 1	1	CAN 1	CAN 1 GND	Common (do not connect)
	2		CAN 1 LOW	
	3		CAN 1 HIGH	
	4	Supply voltage	+24 V DC	Standard power input 1
	5		0 V	
Dill switch 1	-	ON/OFF	CAN 1 Term.	120 $\Omega$ termination
Dill switch 2	-	On/OFF	CAN 2 Term.	120 $\Omega$ termination
Connector 2	6	CAN 2	CAN 2 GND	Common (do not connect)
	7		CAN 2 LOW	
	8		CAN 2 HIGH	
	9	Supply voltage	+24 V DC	Standard power input 2
	10		0 V	



By default, the CAN bus termination switch is set to “OFF”.

### AX1 Analogue extension module connections

AX1 is the extension module enabling the XDi to measure analogue input signals and scale them to absolute data.

When AX1 module is mounted in the extension slot, several inputs and one reference voltage output are available.

The standard rudder libraries require the AX1 module to be mounted in slot 1 on the rear of either XDi 144 or XDi 192. (XDi 96 only has one extension slot)

The different input/output ports and terminal connections are shown in the table below.

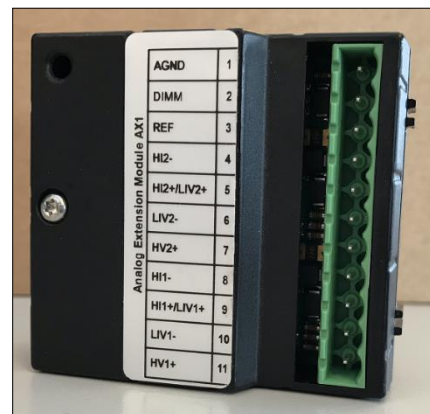

Voltage and current connection			
Terminal no		Signal	Input
+	-		
11	1	High voltage (HV1) input range, max. +/-30 V	Analogue port 1
9	10	Low voltage (LIV1) input range, max. +/- 2 V	
		Low current (LIV1) input range, max. +/- 2 mA	
9	8	High current (HI1) input range, max. +/- 20 mA	
7	1	Hi voltage (HV2) input range, max. +/-30 V	Analogue port 2
5	6	Low voltage (LIV2) input range, max. +/- 2 V	
		Low current (LIV2) input range, max. +/- 2 mA	
5	4	High current (HI2) input range, max. +/- 20 mA	
2	1	Dimmer input/high voltage 3 (DIM/HV3), max. +/-30 V	Analogue port 3
3	1	REF out voltage	Voltage output / reference input

## NX1 NMEA output module connections

NX1 is the extension module enabling the XDi to transmit the rudder angle in a NMEA0183 sentence. This option can be quite useful in systems where the rudder angle must be made available for other systems. The NMEA output on NX1 is galvanically separated from supply voltage, analogue inputs and the CAN bus ports.

Any of the XDi indicators in a rudder system that has a free expansion slot for the NX1 module can be used as an NMEA output source.

The NX1 module has two contact inputs that can be used as pushbutton inputs for dimmer control. To use the pushbutton inputs the selected product profile must support front button dimmer control and the buttons must be activated in the installation menu.

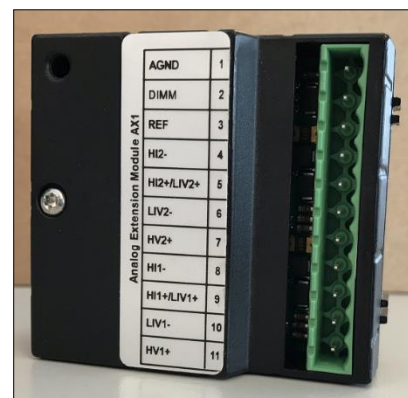

Term. no.	Signal	NX2 Label	Remark
1	Do not use	DO NOT CONNECT (DNC)	Do not connect anything to terminal 1 to 4
2			
3			
4			
5	Contact input 1	C-IN 1	Push-button input 1 with internal pull-up to +5 V
6	Contact input 2	C-IN 2	Push-button input 2 with internal pull-up to +5 V
7	COM 1 output	TX1 – A	RS-422 Differential output (IEC 61162-1)
8	NMEA 0183	TX1 – B	
9	Common GND	COMMON	Used for COM 1 output and the contact inputs
10	Do not use	DNC	Do not connect anything to terminal 10 and 11
11			



**XDi follows the NMEA0183/IEC61162-1 convention for the marking NMEA output terminals.**

## TDG-210DG Analogue insulation amplifier / signal converter

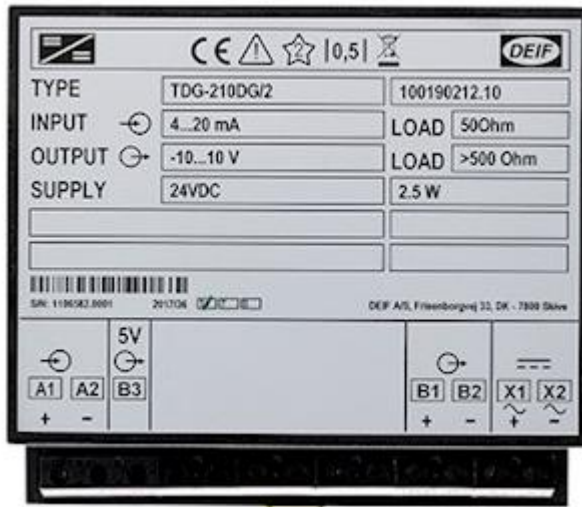

The TDG-210DG analogue insulation amplifier can be configured to receive a current or voltage input signal and convert it to a current or voltage output signal. The input and output are galvanically separated.

In this application note the unit is used to convert the RTC 602 angle transmitter 4-20 mA output signal to a voltage output signal of +/-10 V DC that is distributed to a number of indicators.

The unit can also be configured to have 4-20 mA input and galvanic separated 4-20 mA output. This configuration can be used to buffer a 4-20 mA input signal and thereby extend the number of indicators that can be connected to the angle sensor.

When using a current-to-current configuration, the unit can also be used to divide a rudder indicator system into two or more separate current loop branches. This separation of the system makes it more robust to single faults in the installation. For example, if one of the indicators has a broken wire, then only the indicators connected to the faulty current loop branch are affected by it.

**Example 1:** Angle transmitter with two galvanically separated current loops drive the indicators.

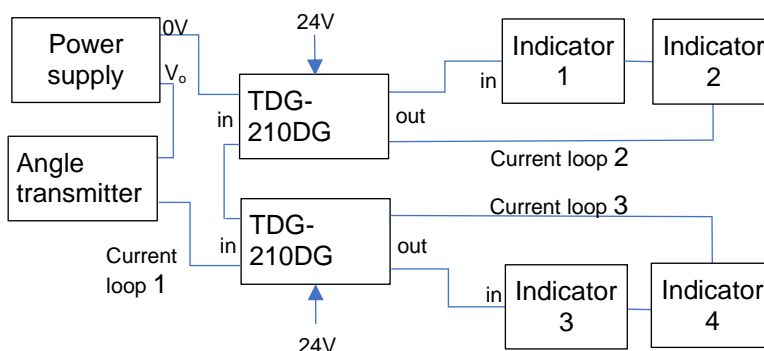

A lost connection to indicator 1 causes indicator 1 and 2 to stop working, but indicator 3 and 4 are not affected.

A lost connection in current loop 1 will shut down the whole system, so the installation of the cabling in loop 1 must be short and very robust.

A short circuit between the input terminals of indicator 1 will only affect indicator 1.

The use of redundant power supply or power supply with battery backup (UPS) should be considered, the same goes for the routing of power cabling to the system component.

**Example 2:** Angle transmitter with two galvanically separated voltage outputs drive the indicators.

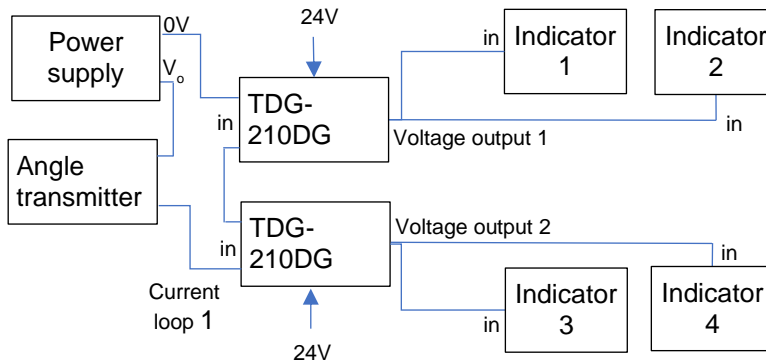

The indicators must be connected directly to the voltage output terminals to obtain the most robust system. (Star coupled)

A lost connection to indicator 1 only affects indicator 1. A short circuit between the input terminals of indicator 1 causes indicator 1 and 2 to stop working, but indicator 3 and 4 are not affected. (The output on TDG is short circuit protected and it will not be damaged.)

A lost connection in current loop 1 shuts down the whole system, so the cabling of current loop 1 and installation must be robust and contain the necessary cable relieves.

The use of redundant power supply or power supply with battery backup (UPS) should be considered for optimal system and component redundancy.

### Ordering TDG-210DG

The TDG-210DG made according to the conversion specified during ordering. During installation it's not possible to make change on the input / output configuration and therefore it's essential to know the correct configuration when the system is ordered.

### RTA/RTC Azimuth/Rudder angle transmitters

There are three rudder transmitters that can be used in DEIF rudder indicator systems. The RTC 300 and 600 with CANopen interface and the RTA with 4-20 mA analogue output.



RTC 300 (small) and RTA 602 / RTC 600



600 series with 90° mounting bracket.

### RTA 602 analogue angle transmitter

The RTA rudder angle transmitter can measure angles from approximately +/-10° to a full +/-180° degree angle. The output is 4-20 mA with a very high resolution.

During installation the zero and min./max. angle values must be calibrated. In some rudder installations, it is not possible to bring the rudder to the max. and min. positions shown at the indicator scale. In such cases the half range calibration option of the RTA can be used instead of full range calibration.

**Example:** On a ship the actual rudder movement is physically limited to +/- 35° and the minimum rudder scale angle in a MED approved rudder indicator system is +/-40°. The indicator input is 4-20 mA.

To calibrate the rudder transmitter in this system:

1. Position the rudder in 0° and set the zero point at 12.0 mA.
2. Position the rudder at -20.0° and use the half range calibration function to set the half range angle at 8.0 mA.
3. Position the rudder at +20.0° and use the half range calibration function to set the half range angle at 16.0 mA.

When the rudder is at its maximum positive angle (+35.0°), the output current is 19.0 mA and the indicator shows 35.0°.

See **System application 3** for more information about how an XDi can make sensor calibration easier.

The RTA is powered directly from the 4-20 mA measuring signal and therefore only requires two wires to work.

The minimum voltage across the rudder transmitter must be 7.5 V DC @ 20 mA.

Wire	Type	Signal	Remark
Pink	I in (+mA)	Current in/out	Min. 7.5V to max. 35V DC at 4...20 mA (Max. range 3.8...20.2 mA)
Brown	I out (- mA)		
Green	S1 (Set 1)	Programming	Programming see: RTA 602 installation instructions 4189350070 or RTA 602 quick guide 4189350051 <b>Normal operation: All 3 set-wires must be connected together.</b>
Yellow	S2 (Set 2)		
Grey	SC (set common)		
White	Not used	Not used	This wire is cut off

More technical and installation details can be found in:

- RTA 602 data sheet 4921250068 UK
- RTA 602 installation instructions 4189350070 UK
- RTA 602 quick guide 4189350051 UK

### RTC 300 or RTC 600 CAN angle transmitters

The RTC type rudder angle transmitter is able to measure an angle of +/-180° angle with 16-bit data resolution. The full circle of 360° is divided into 65535 steps. This means that 1 degree has a resolution of 182 steps.

The default NodeID for DEIF CAN transmitters is 1. It can be reprogrammed using the programming wires (ID 1 to 8).

Data is sent as 2 bytes (signed 16-bit) located in byte 0 and 1 in TPDO1 with the COB-ID: 0x180+NodeID. For the default NodeID it is 0x181.

The zero point and the direction clockwise / counter-clockwise (CW/CCW) can be programmed using the programming wires. See the **RTC 300\_RTC 600 installation instructions 4189350071** for more information about how to set up the RTC.

The rudder indicators that receive relative angle values via CAN must scale it accordingly.

Rudder indicator range	Rudder transmitter angle minimum	Rudder transmitter output value minimum	Rudder transmitter angle maximum	Rudder transmitter output value maximum
+/-40.0°	-40.0°	-7282 (0xE38E)	+40.0°	7282 (0x1C72)
+/-45.0°	-45.0°	-8192 (0xE000)	+45.0°	8192 (0x2000)
+/-50.0°	-50.0°	-9102 (0xDC72)	+50.0°	9102 (0x238E)
+/-70.0°	-70.0°	-12743 (0xCE39)	+70.0°	12743 (0x31C7)

The CAN output value ( $A_{out}$ ) from the RTC rudder transmitter is calculated using this formula:

$A_{out} = 182.04 \times TA$  where TA is the rudder transmitter angle in degrees

See **System application 4** for more information about how an XDi can make sensor calibration easier.

Wire	Marking	Signal	Remark
Blue	0 V	Supply Voltage	18 to 32 V DC @ max. 60 mA
Red	24 V DC		
Green	CAN high	CAN bus	Remember to terminate the CAN bus
Yellow	CAN low		
White	Set 1	Programming	<b>Normal operation: All 4 set-wires must be connected to 0 V (Blue).</b>
Grey	Set 2		
Pink	Set 3		
Brown	Set 4		

More technical and installation details can be found in:

- RTC 300\_RTC 600 data sheet 4921250069 UK
- RTC 300\_RTC 600 installation instructions 4189350071 UK
- RTC 300-600 quick guide 4189350052 UK

### Mounting accessory for RTA 602 and RTC 600

#### Rudder connection parts

The RTA 602 and RTC 600 are both very robust and can be mounted directly on the rudder using the position linkage mounted on the transmitter and the lever with a max length of 1127 mm attached to the triangle of the rudder.



1124410003 Adjustable lever max. length is 1127 mm

1124410004 Position linkage 317 mm

### 90° mounting bracket for RTA 602 or RTC 600

The 600 series heavy duty angle transmitters can be delivered with or without the 90° mounting bracket. It is also possible to order this bracket separately as accessory.

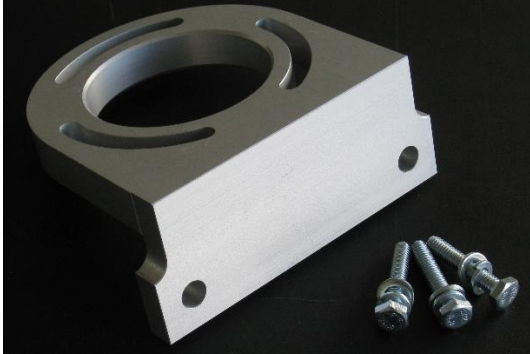

1220000010 90° mounting bracket for RTA 602 or RTC 600 (Compatible with old RT-2 bracket)

### RTA/RTC Order information

Type	Product name	Order number
RTA 602	RTA 602 angle transmitter with 90° mounting bracket. Analogue 4-20 mA, set by wire +/- 20 to 180 deg.	2951860010-01
	RTA 602 angle transmitter without mounting bracket. Analogue 4-20 mA, set by wire +/- 20 to 180 deg.	2951860010-02
RTC 600	RTA 602 angle transmitter with 90° mounting bracket. CANopen, for rudder or azimuth angle of max. +/-180 deg.	2951860010-03
	RTA 602 angle transmitter without mounting bracket. CANopen, for rudder or azimuth angle of max. +/-180 deg.	2951860010-04
RTC 300	RTC 300 angle transmitter CANopen, for rudder or azimuth of max. +/-180 deg. standard ø50 mm house and ø6 mm shaft	2951860010-05

## System applications

### System application 1 – Traditional current loop 4-20 mA

The 4 to 20 mA current loop is easy to install. It only requires a single signal wire routed from a 24 V DC voltage source in a loop through the RTA 602 (rudder angle transmitter) and each individual indicator and back to the voltage source.

The current loop is not sensitive to fluctuations in the supply voltage. It is important that the voltage source driving the current loop is able to supply sufficient voltage to drive all the connected indicators and the rudder angle transmitter electronics, including the voltage drop in the signal wire loop at maximum current of 20 mA.

RTA 602 has a 2-wire configuration and does not need an extra auxiliary power supply voltage.

The TRI-2 indicator requires a 24 V DC supply for the backlight where the XL/BW/BRW type indicators require a 24 V DC auxiliary power supply in order to function.

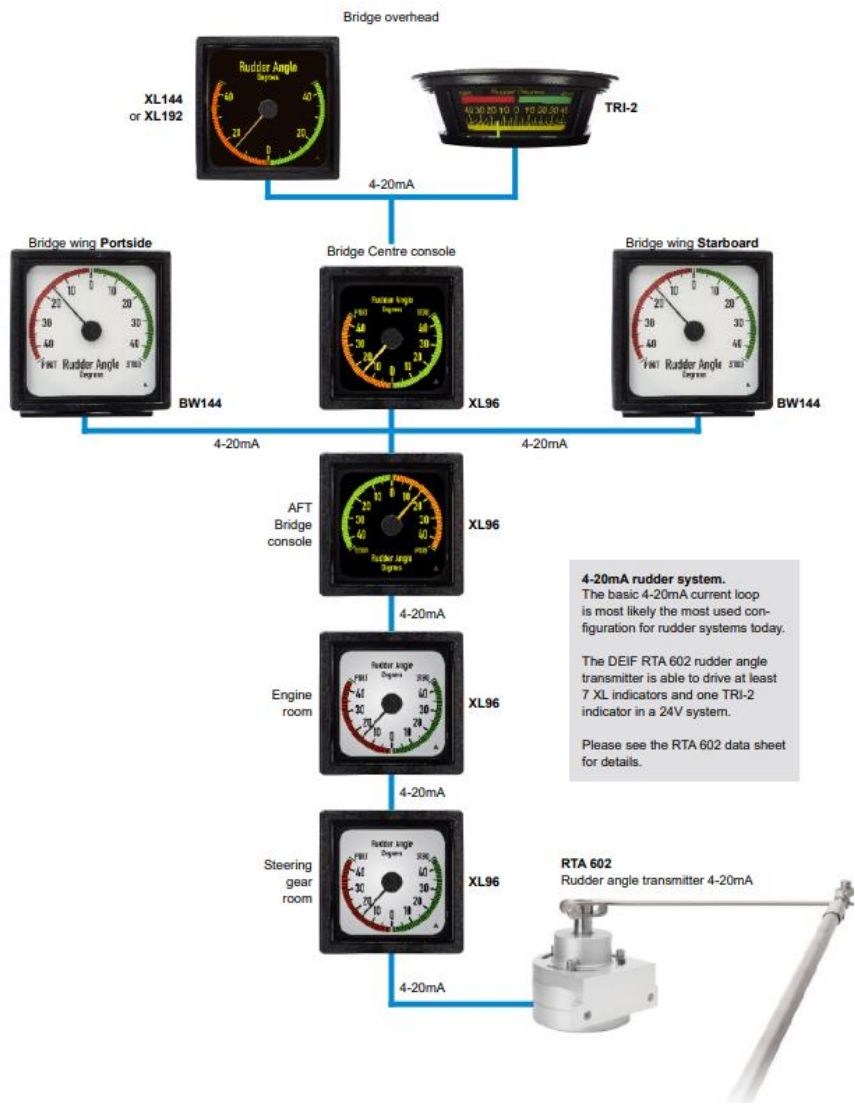

In rudder indicator systems with many indicators, it is always a good idea to make a load calculation to make sure that there is sufficient margin to run the system under all conditions.

**See Appendix 2** for a description of how to make load calculations to secure a stable operation in all working conditions.

See **System application 2** if more than 8-10 indicators are needed in a system.

### Fault situations

A short circuit of the input terminals on one of the indicators will only affect indication on the short-circuited indicator, the other indicators will not be affected.

A single disconnection in the current loop will interrupt operation of the entire indicator system. This is shown when the pointer on all indicators moves out of the scale. For an indicator with clockwise deflection, the pointer is on the left side of the scale to indicate a 0 mA input current.

### Dimming

Each XL indicator can be dimmed. The backlight dimming requires a voltage of 7 to max. 30 V DC between terminal 6 (illumination positive) and 7 (illumination GND). The voltage can either be from an external supply voltage or a connected potentiometer.

### Adjustment

The RTA has no physical zero markings and is therefore mounted without making any physical zero alignment. Follow these steps to electrically zero align the RTA:

1. Use the locally mounted XL indicator as reference for the calibration, if it is visible from the RTA cable access point.
  - If this is not possible, a mA-meter in series with the signal line can be used to control the calibration values.
2. Use the three control wires (yellow, green and grey) from the RTA to calibrate the zero point and the min./max. range.
  - See the RTA 602 installation instruction for more information.
3. When the rudder angle transmitter has been properly calibrated, check the other indicators in the system.
4. Optional: Fine-tune each indicator in the system by means of the adjustment potentiometers on the back of the indicator.
  - **Note** Do not fine-tune the indicators if there is an incorrect signal from the transmitter which should have been adjusted in step 1 and 2. The XL/BW indicator can only be adjusted approximately +/- 2%.

## System application 2 – Traditional +/-10 V system

In a +/-10 V rudder indicator system, the output signal is routed to each indicator in the system in a star configuration. As opposed to the 4 to 20 mA current loop, where all indicators in the loop will lose signal if the loop is broken, the remaining indicators in a voltage system are not affected if the input to one indicator is lost.

The RTA 602 rudder angle transmitter supplies the 4-20 mA signal to the TDG-210DG which is a galvanically separated amplifier that converts the 4-20 mA to +/-10 V. The voltage signal is routed to each indicator in the system. RTA 602, TDG-210DG and the XL indicators require a 24 V DC auxiliary supply. TRI-2 does not require an auxiliary supply voltage.

The +/- 10 V output from the TDG-210DG is not sensitive to fluctuations in the supply voltage. It is important that the connected indicators do not draw more than 20 mA in total from the output on TDG-210DG.

### Fault situations

In the 4-20 mA current loop part, see the fault description in **System application 1**.

Faults in the system after TDG-210DG – the star coupled indicators:

- A short circuit of the input terminals affects all indicators connected to the TDG-210DG.
- Losing an input connection to one of the voltage driven indicators only affects that specific indicator, the rest of the system is not affected.



### System application 3 – Combined 4-20 mA and CANopen system

This system solution combines the use of an analogue rudder angle transmitter with high accuracy data distribution via CAN bus.

The system shown is an example of how the different DEIF indicators can be used in combination with a rudder indicator system.

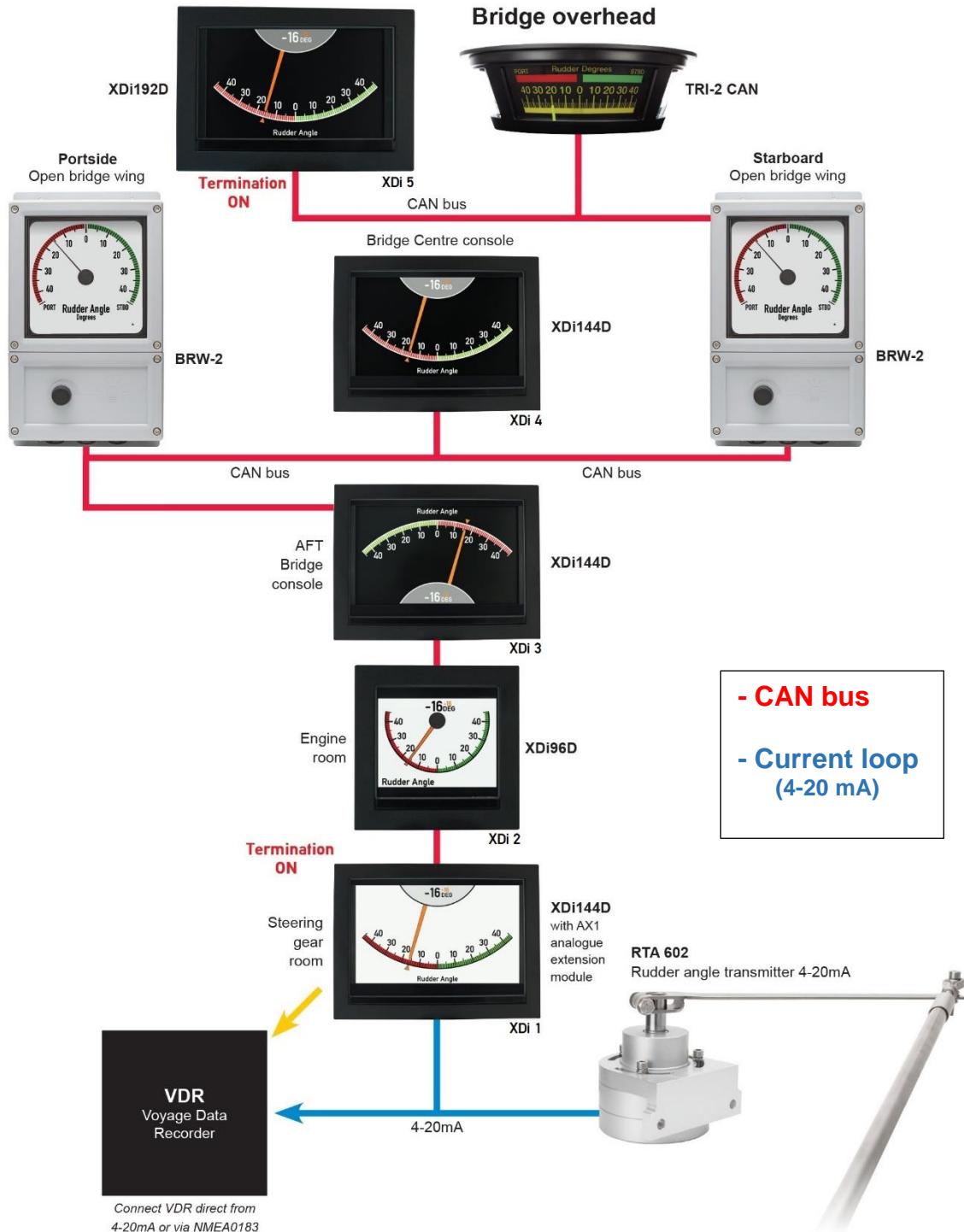

XDi 1, located in the steering gear room, is equipped with an AX1 analogue extension module to which the 4-20 mA signal from the RTA 602 is connected. This XDi unit not only presents the rudder angle, it also transmits the rudder angle on CAN bus to the other indicators in the system.

In other words, it acts as a converter box from 4-20 mA to CAN (similar to TDG-210DG in System application 2).

The standard virtual rudder indicator used in this system is setup to transmit the rudder angle value in both XDi-net format and also as a sCAN message by default. The sCAN has an sID=10 (TPDO1 from NodeID 10, COB-ID 0x18A).

The XDi indicators in the system use the XDi-net Plug & Play format and the XL, BW, BRW and TRI-2 indicators use the sCAN format.



**According to MED the rudder indicator system shall be a separate system. There must only be one XDi rudder indicator with an analogue input in this system. Contact DEIF support for more information about running two or more rudder systems on the same CAN bus.**



**Except for the XDi indicator in the steering gear room all other indicators can be changed to another DEIF indicator with CAN, or it can be removed from the system. The XDi with analogue rudder input can be located anywhere in the system, as long as there is only one.**

**Connecting the analogue part**

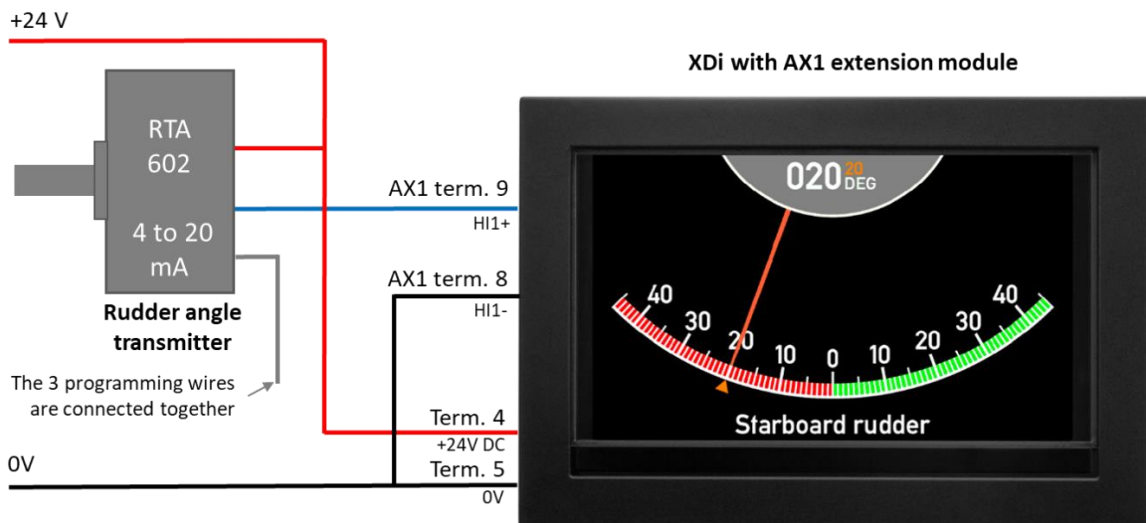

**Analogue input connections**

RTA 602 rudder transmitter	Function		XDi 1 term.	AX1 term.	Power supply
	Supply voltage	-	5	-	0 V
Red wire		+	4	-	+ 24 V DC
	Current loop	HI	-	9	
Blue wire		+	-	8	
		HI	-	8	
Shield	Electrical shielding of data signal cable		No connection		
Green, yellow and grey wires	Setup wires		No connection		

Note: In normal operation all 3 setup wires must be connected together.

### CAN system connections

Function		XDi 1 term.	XDi 2 term.	XDi 3 term.	BRW-2 term.	XDi 4 term.	BRW-2 term.	TRI-2 term.	XDi 5 term.	Power supply
Supply voltage	-	5	5	5	-	5	-	2	5	0 V
	+	4	4	4	+	4	+	1	4	+ 24 V DC
CAN 1 Low		2	2	2	84	2	84	8	2	
CAN 1 High		3	3	3	83	3	83	7	3	
CAN cable shield		Connected between cables, but no connection to the indicators								
CAN 1 termination		ON	OFF	OFF	OFF	OFF	OFF	OFF	ON	

### Replace one of the rudder indicators with an XL CAN

It is possible to replace any of the indicators in the CAN system with an XL sCAN rudder indicator, except XDi no. 1 because this indicator also acts as the analogue to CAN converter in the system.

Replace the relevant indicator connections in the table above with the content of the table below:

Function		XL CAN term.
Supply voltage	-	1
	+	2
CAN 1 Low		4
CAN 1 High		3
CAN cable shield		NC
CAN 1 termination		Not available *

\* Note: See CAN bus termination below

### CAN bus termination

It is very important to terminate the CAN bus in both ends, failing to do so will result in an unreliable CAN bus operation.

In this example the XDi is located in both endpoints of the CAN bus, and the CAN bus can be terminated by activating the internal CAN bus termination resistor in the XDi.

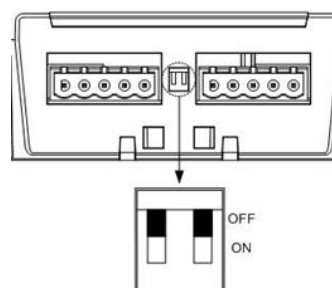

If a BRW-2 and TRI-2 CAN is located in an endpoint of the Can bus, the build in termination resistor can be activated.

XL CAN does not have built in termination resistor. If XL is the first or last unit on the CAN bus, then an external 120 Ω resistor must be connected between terminal 3 and 4 to terminate the bus.

## Dimming

Dimming of traditional and display based indicators is a challenge since the traditional indicators require no backlight in bright daylight conditions, where the display-based indicator requires maximum backlight to overcome the bright light.

In this example system the TRI-2 CAN and BRW-2 are dimmed locally via the built-in potentiometer. In both cases it is possible to replace the potentiometer with an external dimming control. It can be beneficial to have an external dimmer control in the panel for the ceiling-mounted TRI-2 CAN.

The XDi indicators offer a wide range of dimmer control options:

- CAN bus
- External voltage dimmer input
- External potentiometer connection
- External pushbuttons
- Buttons on the XDi front

All external dimming functions, except dimming via CAN bus, require the use of an extension module.

The front button dimmer control on XDi requires the four-button front frame kit, available as option or accessory, and the XDi library version must be version 2000 or higher. The standard rudder indicator libraries support this function.

An XDi unit with an external front dimmer control can share the dimmer level via XDi-net (CAN bus) for a group of XDi indicators connected to the same CAN bus.

In installations with a number of separate indicator systems using XDi, it can be beneficial to use CAN bus 2 as a dimmer control bus. In this way the separated indicator systems can be interconnected without jeopardising the system separation. This is possible due to the galvanic separation of the two CAN busses.

Dimming from the front buttons is selected in this system application example for both indicators. Since they are connected via XDi-net (CAN), the dimmer level will be synchronised between the two indicators. By default, the indicators are assigned to dimmer group 1.

See **Appendix 3** for other dimmer alternatives.

## XDi Installation setting

Order the XDi unit with the DEIF standard rudder library 031. This library contains a selection of virtual rudder indicators.

The library contains indicators with standard scales for +/-40°, +/-45°, +/-50°, +/-70° and for use on a forward or aft pointing bridge respectively.



Rudder angle indicator +/-70° forward (VI007)



Rudder angle indicator +/-45° aft (VI004)

In addition, there is a special MED compliant rudder indicator for use in systems where the rudder angle is below 40 degrees. This indicator has a +/- 40° scale (minimum scale required by ISO 20673) and with a configurable grey scale.

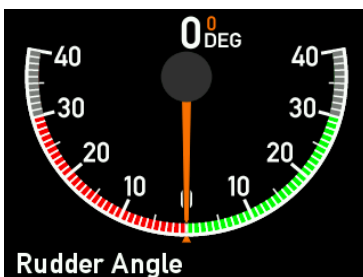

Example of XDi 96 D scale configured to +/- 30°

Contact DEIF if the rudder scale you need is not in the standard library. The scale could already be added or is in the process of being added. It is also possible to have a unique customised indicator design if required. XDi is made for easy customisation of indicators.

**Installation wizard**

When the XDi has not yet been set up, it will automatically start the start-up wizard.

In the table below, you find the correct XDi setup for the system example.

**Select the CAN NodeID.**

In this application XDi-net (on CAN bus) is used to share data with other indicators in the system. All the XDi indicators must have a different CAN NodeID. It is not important which ID you select for the XDi indicators as long as they are different. The suggested CAN node IDs are found in the tables below.

The example system uses the DEIF standard rudder indicator library no. 031 and the rudder indicator selected is +/- 45°.

XDi indicator no. 1 - Steering gear room (including analogue to CAN bus conversion) AX1 module is required.		
Node ID: 30 (Default)		
Product Profile	Virtual indicator	VI setup
PP06 – ECR fixed dimmer Group: Local	VI003 +/-45 degrees forward bridge indicator	VS04 Analogue system 4-20 mA input

XDi indicator no. 2 – Engine room			
Node ID: 31			
Product Profile	Virtual indicator	VI setup	Note
PP06 – ECR fixed dimmer Group: Local	VI003 +/-45 degrees forward bridge indicator	VS01 XDi-net	This XDi will receive accurately calibrated data form XDi 1 via CAN bus

XDi indicator no. 3 – AFT bridge			
Node ID: 32			
Product Profile	Virtual indicator	VI setup	Note
PP01 – Front dimmer / XDi-net Dimmer group 1*	VI004 +/-45 degrees aft bridge indicator	VS01 XDi-net	This XDi will receive accurately calibrated data form XDi 1 via CAN bus

XDi indicator no. 4 – Centre console (Forward bridge)			
Node ID: 33			
Product Profile	Virtual indicator	VI setup	Note
PP01 – Front dimmer / XDi-net Dimmer group 1*	VI003 +/-45 degrees forward bridge indicator	VS01 XDi-net	This XDi will receive accurately calibrated data form XDi 1 via CAN bus

XDi indicator no. 5 – Overhead panel (Forward bridge)			
Node ID: 34			
Product Profile	Virtual indicator	VI setup	Note
PP01 – Front dimmer / XDi-net Dimmer group 1*	VI003 +/-45 degrees forward bridge indicator	VS01 XDi-net	This XDi will receive accurately calibrated data form XDi 1 via CAN bus

\* Note: Select another product profile (PP) if you want to use another type of dimmer input. See **Appendix 3** for more information.

See **Appendix 1** for more information about the XDi first-time setup procedure.

### Commanded rudder presentation on XDi

All the standard XDi rudder indicators have a small triangle pointer and an orange digital readout showing the commanded rudder angle.

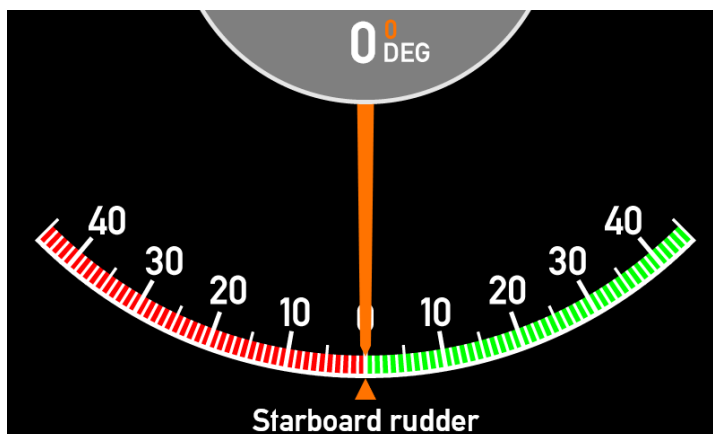

In this example the XDi system can receive the commanded rudder angle as an analogue 4-20 mA signal connected to the AX1 module on the XDi in the steering gear room (XDi 1). XDi 1 will scale the input and distribute it automatically via XDi-net (CAN) to all the other XDi units in the system.

### Disabling commanded rudder indication

If you don't want to use commanded rudder indication, it can be disabled.

The commanded rudder indication must be disabled on all XDi indicators if you do not want to use this feature. If it is not disabled on all indicators, it will be presented with a fixed value that is out of range or as a data lost indication if it is setup to use CAN data.

See **Appendix 5** for more information about disabling the commanded rudder indication.



### BRW-2, BW144/192 or XL configuration

The traditional indicators (BRW-2, BW or XL) used in this rudder system, must be ordered with single CAN input (sCAN). XL with sCAN is a listen only device on the CAN bus.

The XL type indicators in the example system have the following configuration:

Input: Single CAN  
 Source NodeID: 10 (Data is sent from XDi in CAN TPDO1 with COB-ID: 0x18A)  
 Application type: General  
 Input type: Absolute (16-bit signed, rudder angle value x 10 (Resolution 0.1))  
 Input min. -450 (equal to -45.0° PS, this must match the min. scale value)  
 Input centre 0  
 Input max. +450 (equal to +45.0° SB, this must match the max. scale value)

See the table below to determine the EM (Pointer position at electrical mid. of input) and the pointer turning direction.

Input value on CAN1	Pointer position	FWD design EM=6 o'clock Pointer CCW	AFT design EM=12 o'clock Pointer CCW
-450	PS (red) -45.0°		
0	PS (red) 0.0°		
450	SB (green) +45.0°		

The standard rudder scales shown above are available for XL, BW and BRW-2 indicators.

See **Illuminated indicators, standard scale designs** 4921290030 for more examples of standard scales.

In addition to the scales mentioned in this document, DEIF holds a high number of other scale designs that may suit your need. Contact our customer care for more information.



**It is also possible to have a customised rudder scale made to match your need.**

### TRI-2 CAN configuration

TRI-2 is available in a special CAN bus version in addition to the traditional analogue input version. For this system the TRI-2 CAN version must be ordered.

Order number: **2951460020 variant 02**

The TRI-2 CAN in the example system has the following configuration:

Input type: Single CAN from XDi as transmitter  
 Source NodeID: 10 (Data is sent in byte 0 & 1 of CAN TPDO1 with COB-ID 0x18A)  
 Select standard scale: +/-45 red/green

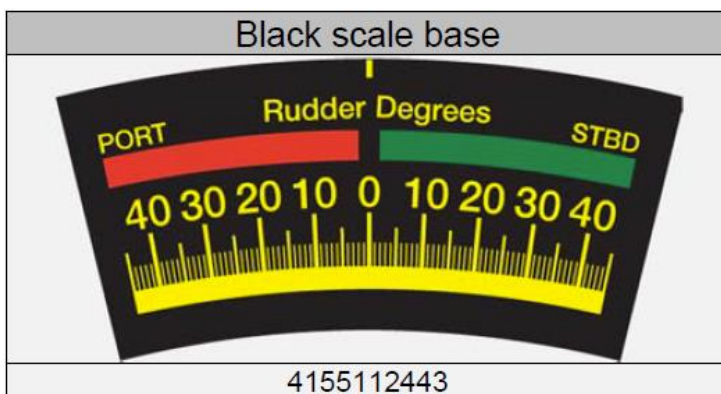

### Standard black scales with yellow pointer

FWD	±45 red/green scale no.	414155112443
AFT	±45 green/red scale no.	414155112444
FWD	±45 red/green scale no.	414155110872
FWD	±50 red/green scale no.	414155112445
AFT	±50 red/green scale no.	414155112439
FWD	±70 red/green scale no.	414155112440
AFT	±70 red/green scale no.	414155111433
FWD	±180 red/green scale no.	414155112595

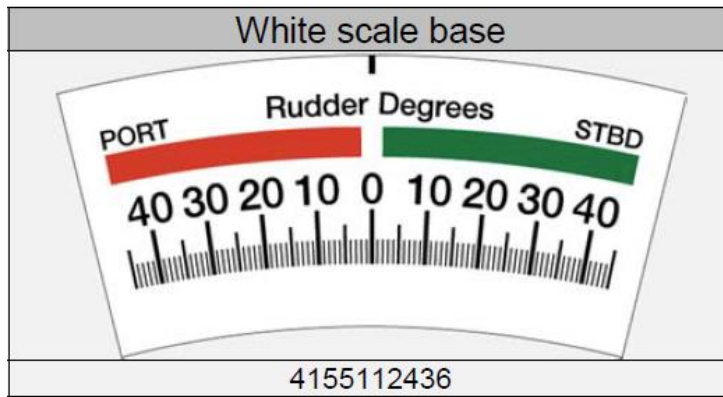

#### Standard white scales with black pointer

FWD	±45	red/green scale no. 41	4155112436
AFT	±45	green/red scale no. 41	4155112437
FWD	±50	red/green scale no. 41	4155112438
AFT	±50	red/green scale no. 41	4155112439
FWD	±70	red/green scale no. 41	4155112440
AFT	±70	red/green scale no. 41	4155112441

Contact DEIF if you don't find the scale you need in the above, new scales may have been added.

#### Installation and calibration of the rudder system

The system can be calibrated after it is installed on-board and the XDi indicators are setup according to the previous chapters.

When XDi is used as an analogue to CAN converter it is easy to setup the system also in the cases where the physical rudder movement is not able to reach the min/max points on the rudder scale.

#### Example

In this example, the maximum rudder movement is 41.0° to portside from zero and 39.5° to starboard. The full 4-20 mA signal is used to reflect the maximum rudder span.

#### Calibrate the angle transmitter

The angle transmitter is delivered with a +/-180° range. In the actual installation you must calibrate the sensor to match your rudder movement.

The calibration is performed using the 2 programming wires and the common wire in the RTA 602 cable. (Green S1, Yellow S2 and Grey: set common).

Use the "RTA 602 installation instructions 4189350070" for detailed information.

The "RTA 602 quick guide 4189350051" that is included with the RTA 602 can also be used.

#### Calibrating steps:

##### Step 1 – Zero set.

Position the rudder in 0 degree and perform the CW zero set sequence.

##### Step 2 – Portside min.

Position the rudder in the utmost portside, note the physical rudder angle in degrees (in the example 41.0° PS) and perform the min./max. calibration sequence. The rudder angle is now set to either 4 or 20 mA depending of the direction the sensor is rotated when the rudder is positioned in utmost PS.

The XDi will now show either +45°(SB) or -45° (PS).

Make a note of the max. rudder angle you will need that.

### Step 3 – Starboard max.

Now the RTA 602 is calibrated to use the full 4-20 mA resolution to present the rudder angle range.

All the rudder indicators in the system now show a value between  $-45.0^\circ$  and  $45.0^\circ$  when the rudder moves between  $-41.0^\circ$  (PS) and  $39.5^\circ$  (SB).

This can easily be re-scaled via the installation menu on XDi 1 (the XDi connected to the RTA).

#### Rescale the rudder angle input

Press button 1 and 4 at the same time for 5 sec to open the User menu.

Press button 2 and 3 at the same time for 5 sec to open the installation menu.

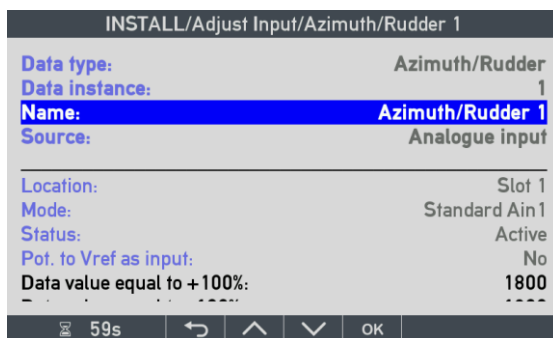
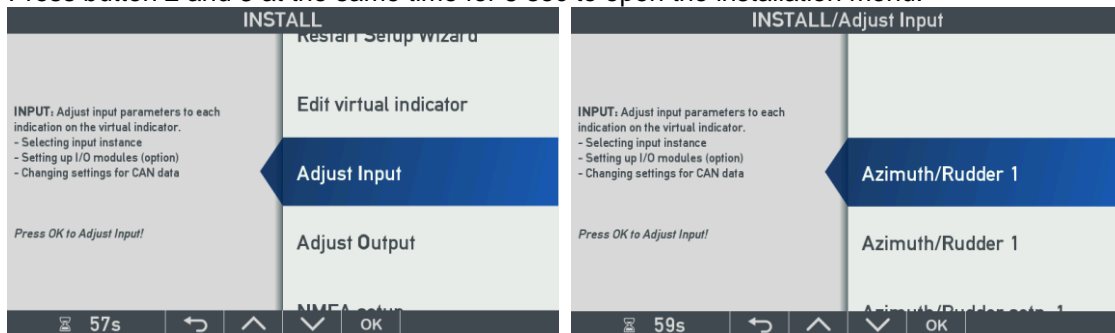

Make the above selections to enter the Azimuth/Rudder input adjust menu.

Scroll down to the analogue input part of the menu.

The rudder input is setup for 3-point linearization this means that there is an input/output pair for minimum rudder (PS), zero rudder and max rudder (SB). the input is setup as a 4 to 20 mA input.

Input point 1 is  $4000\ \mu\text{A}$ , input point 2 is  $12000\ \mu\text{A}$  and input point 3 is  $20000\ \mu\text{A}$

INSTALL/Adjust Input/Azimuth/Rudder 1	
Direction:	CW
<b>Analogue input</b>	
Input type:	+/- 20 mA
Multi point linearization:	3
Input point 1:	4000
Output point 1:	-450
Input point 2:	12000
Output point 2:	0
Input point 3:	20000
56s [Back] [Up] [Down] [OK]	

Scale the output to match the actual rudder angels.

Output point 1 (PS) shall be changed to  $-41.0^\circ$ . This means that we will enter the value -410 since XDi is using an internal  $0.1^\circ$  resolution of the angle.

INSTALL/Adjust Input/Azimuth/Rudder 1	
Choose a value:	min. -32768 <b>-00410</b> max. 32767
57s [Back] [Up] [Left] [OK]	

Press OK to save the new value.

INSTALL/Adjust Input/Azimuth/Rudder 1	
<b>Analogue input</b>	
Input type:	+/- 20 mA
Multi point linearization:	3
Input point 1:	4000
Output point 1:	-410
Input point 2:	12000
Output point 2:	0
Input point 3:	20000
Output point 3:	450
59s [Back] [Up] [Down] [OK]	

Next, the output point 3 value must be changed to  $+39.5^\circ$  or 395 with resolution  $0.1^\circ$

INSTALL/Adjust Input/Azimuth/Rudder 1

Choose a value: min. -32768 **+00395** max. 32767

58s [Back] [Up] [Left] [OK]

Press OK to save the new value.

INSTALL/Adjust Input/Azimuth/Rudder 1

Analogue input

Input type:	+/- 20 mA
Multi point linearization:	3
Input point 1:	4000
Output point 1:	-410
Input point 2:	12000
Output point 2:	0
Input point 3:	20000
<b>Output point 3:</b>	<b>395</b>

55s [Back] [Up] [Down] [OK]

Now the calibration is completed and the total system is showing the correct rudder angle, with a very high accuracy.

If the zero rudder was not correctly adjusted when the RTA was zero adjusted. It is possible to fine adjust output point 2. If there is a small zero fault it can be changed either by adjusting the input point 2 value 12000  $\mu$ A or the output point 2 value. It depends what is the easiest to do in the actual case. XDi will just scale the parameters accordingly.

INSTALL/Adjust Input/Azimuth/Rudder 1

Mode:	Standard Ain1
Status:	Active
Pot. to Vref as input:	No
Data value equal to +100%:	1800
Data value equal to -100%:	-1800
Direction:	CW

Analogue input

Input type:	+/- 20 mA
Multi point linearization:	3

59s [Back] [Up] [Down] [OK]

#### If the pointer turns the wrong way

If the pointer on XDi 1 rotates towards portside when you move the rudder to starboard, then change CW to CCW on the RTA 602 sensor. In this case you must recalibrate the sensor following step 1 to 3.

Alternatively, you can make the change in the XDi installation menu, under **Adjust input**:

INSTALL/Adjust Input/Azimuth/Rudder 1	
Input type:	+/- 20 mA
Input error value min.:	3500
Input error value max.:	21000
Multi point linearization:	3
Input point 1:	4000
Output point 1:	450
Input point 2:	12000
Output point 2:	0
Input point 3:	20000
Output point 3:	-450

49s   ←   ^   v   OK

Change Output point 1 from -450 to +450 and Output point 3 from 450 to -450. The movement of the pointer will change direction and the sign of the digital readout will change accordingly.

#### Note the following

The +/-100 % values are not used in this indicator type and shall not be changed.

Data value equal to +100%:	1800
Data value equal to -100%:	-1800
Direction:	CW



**Don't change the "Direction" parameter from CW to CCW, since this function reverses the input signal.**

Changing the directions means that a 4 to 20 mA (CW) will be measured as -4 to -20 mA (CCW). This does not give the desired result.

If you have reconfigured the input, for example, to a +/-10 V input signal, then the CW/CCW function can be used to change direction. Or the input wires can be swapped around to get the same result.

#### New input lost function implemented in March 2020:

The new input lost function defines the valid measuring range for the analogue input.

Input error value min.:	3500
Input error value max.:	21000

If the measured current (in  $\mu\text{A}$ ) or voltage (in mV) is outside the specified min./max. range above, XDi will release an input signal warning pop-up stating: "AX1 S1 input error".

For the 4-20 mA input and the above settings a data lost / input signal error will be detected if one of the input wires are broken.

When the input is lost, the XDi will also stop transmitting CAN data and data loss will also be detected in all other devices connected via the CAN bus.

### **System application 4 – Full CANopen system 1**

The CAN systems are based on CANopen data distribution from the RTC 600 (or RTC 300) high accuracy CANopen angle transmitter to all the indicators in the system.

The CAN bus-based rudder indicator system offers the absolute best possible rudder angle accuracy.

In the top you find the fully digital XDi rudder system, where the rudder angle is measured with a 16-bit data resolution, giving a 1/182 degree angle resolution. The digital data distribution and full digital signal processing in the XDi gives practically no degradation in accuracy. The calibration of the rudder system during installation, is also very easy. Simply make the calibration on one XDi unit and allow this XDi to synchronize all calibration settings to all other XDi rudder indicators on the CAN bus when you leave the installation menu.

A CAN based systems with traditional XL, BW, BRW-2 and/or TRI-2 CAN indicators is still a very accurate systems, but the extra conversion of the digital angle value to a mechanical pointer position on a scale, degrades the accuracy slightly compared to the fully XDi based system. Calibration of zero, min and max in this system is also relatively simple, using a programming wire between 2 terminals. The calibration can be performed on one XL (BW or BRW-2) indicator and it will automatically be shared with other XL, BW or BRW-2 rudder indicators on the CAN bus. TRI-2 CAN requires separate calibration.

It is also possible to combine XDi with traditional CAN indicators (XL, BW...) to form a very accurate rudder indicator system. This system type is also very easy to calibrate via the menu in one XDi and additional calibration of the traditional indicators will normally not be necessary.

In the following there will be application examples of 2 different CAN based systems.

### CAN system 4.1 – All indicators are type XDi

All indicators receive raw CAN data directly from the angle transmitter. Calibration can be made via the menu in any of the XDi indicators and the calibration result is then synchronized with all the other XDi indicators in the system. Fast and easy.

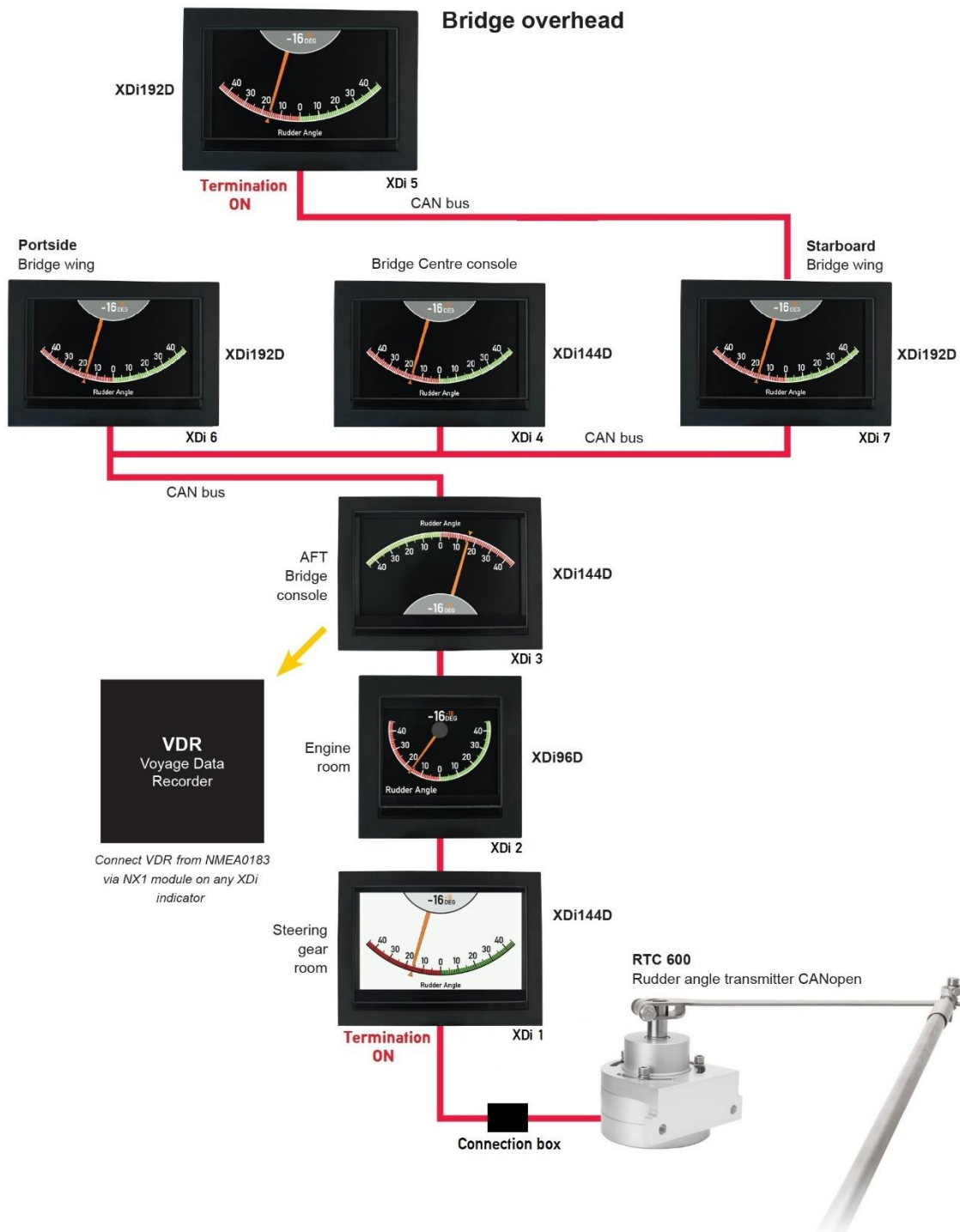

**CAN bus termination:** If the CAN cable between XDi 1 and the RTC rudder transmitter is longer than 10 meters the termination resistor in XDi must be switched OFF. Instead the 120 Ω resistor supplied with the RTC is mounted from CAN high to CAN low in the connection box between RTC transmitter and XDi 1.

### Connecting the RTC CAN angle transmitter to the indicators

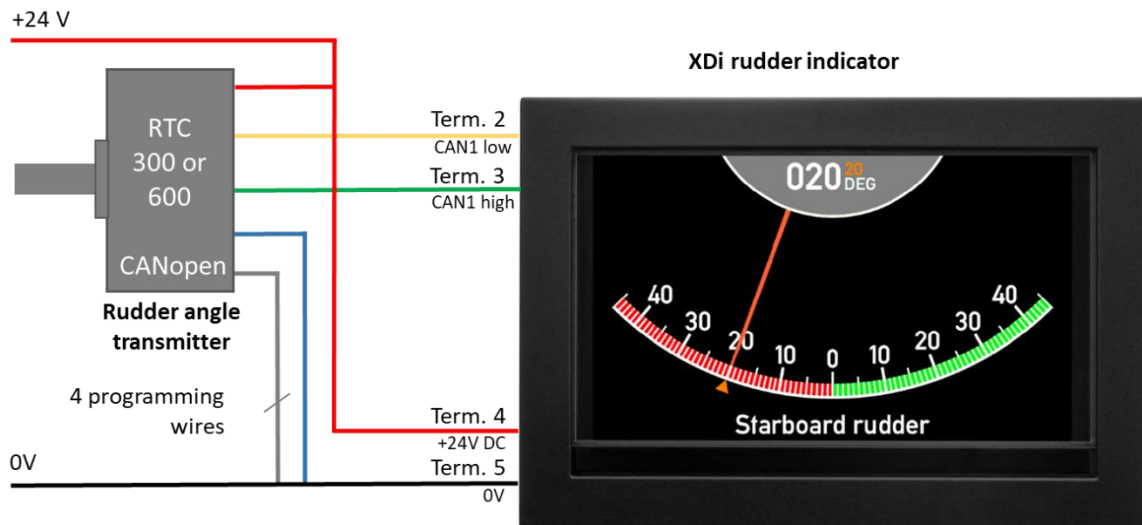

### Connecting RTC to XDi via CAN bus 1

RTC 300 or RTC 600 CAN rudder transmitter	Function	XDi 1 term.	Power supply
Blue wire	Supply voltage	-	0 V
Red wire		+	+ 24 V DC
Green	CAN	High	
Yellow		Low	
Shield	Electrical shielding of data signal cable	No connection	
White Grey Pink Brown	Programming wires After programming connect all to 0 V (blue wire)	(5)	0 V

### CAN system connections

Function		XDi 1 term.	XDi 2 term.	XDi 3 term.	XDi 4 term.	XDi 5 term.	XDi 6 term.	XDi 7 term.	Power supply
Supply voltage	-	5	5	5	5	5	5	5	0 V
	+	4	4	4	4	4	4	4	+ 24 V DC
CAN 1 Low		2	2	2	2	2	2	2	
CAN 1 High		3	3	3	3	3	3	3	
CAN cable shield	Connected between cables, but no connection to the indicators								
CAN 1 termination		ON	OFF	OFF	OFF	ON	OFF	OFF	

### CAN bus termination

It is very important to terminate the CAN bus in both ends, failing to do so will result in unreliable CAN bus operation.

In this example an XDi is located in both endpoints of the CAN bus. Activate the internal CAN bus termination resistor in the XDi units located in both ends of the CAN bus to terminate the CAN bus.



### Dimming of an XDi system.

The XDi indicators offer a wide range of dimmer control options:

- CAN bus
- External voltage dimmer input
- External potentiometer connection
- External pushbuttons
- Buttons on the XDi front (optional)

All external dimming functions, except dimming via CAN bus, requires the use of an extension module.

The front button dimmer control on XDi requires the four-button front frame kit, available as accessory, and the XDi library version must be version 2000 or higher. The standard rudder indicator libraries support this function.

An XDi unit with external or front dimmer control can share the dimmer level via XDi-net (CAN bus) for a group of XDi indicators connected to the same CAN bus.

In installations with a number of separate indicator systems using XDi, it can be beneficial to use CAN bus 2 as a dimmer control bus. In this way the separated indicator systems can be interconnected without jeopardising the system separation. This is possible due to the galvanic separation of the two CAN busses.

It is possible to control dimming via CAN and divide the system into dimmer groups (max. 9 groups) independent of the selected dimming input type. XDi 3 to XDi 7 can for example be controlled as one group. The default is dimmer group 1.

It can be one of the indicators controlled by a dimmer potentiometer (AX1 module required) that controls all indicators in the group. It can also be dimming via front button on one or more XDi indicators in the group. (Front button option or kit is required.)

In this example we will control dimmer group 1 via a potentiometer connected to an AX1 module on XDi 4.

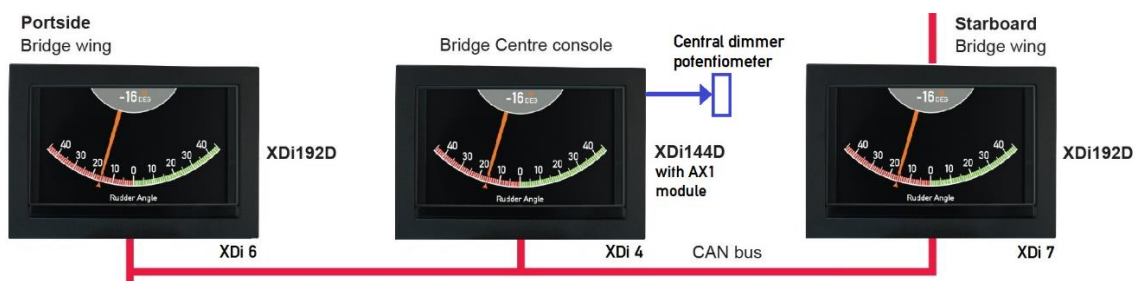

For the XDi units located in the steering gear room and engine control room, a fixed dimmer level and dimmer group "Local" is often used. Local means that dimming is not controlled via the CAN bus.

Note that the default dimmer group is 1 for most of the product profiles, except for the ECR profile that has a fixed dimmer level and is pre-set to "Local".

See **Appendix 3** for other dimmer alternatives.

Order the XDi unit with the DEIF standard rudder library 031. This library contains a selection of virtual rudder indicators.

The library contains indicators with standard scales for  $\pm 40^\circ$ ,  $\pm 45^\circ$ ,  $\pm 50^\circ$ ,  $\pm 70^\circ$  and for use on a forward or aft pointing bridge respectively.



Rudder angle indicator +/-70° forward (VI007)



Rudder angle indicator +/-45° aft (VI004)

In addition, there is a special MED compliant rudder indicator for use in systems where the rudder angle is below 40 degrees. This indicator has a +/- 40° scale (minimum scale required by ISO 20673) and with a configurable grey scale.



Example of XDi 96 D scale configured to +/- 30°

Contact DEIF if the rudder scale you need is not in the standard library. The scale could already be added or is in the process of being added. It is also possible to have a unique customised indicator design if required. XDi is made for easy customisation of indicators.

### Installation wizard

When the XDi has not yet been set up, it will automatically start the start-up wizard.

In the table below, you find the correct XDi setup for the system example.

### Select the CAN NodeID.

In this application example all XDi units receive the angle value directly from the RTC 600 CAN angle transmitter. By default, the unit has NodeID 1 and is transmitting angle data as a 16-bit value in byte 0 and 1 in TPDO1 with COB-ID 0x181.

All devices on the CAN bus must have different CAN NodeIDs. It is not important which ID you select for the XDi indicators as long as they are different. The suggested CAN node IDs are found in the tables below.

The example system uses the DEIF standard rudder indicator library no. 031 and the rudder indicator selected should be +/-45°.

XDi indicator no. 1 - Steering gear room (including analogue to CAN bus conversion)			
Node ID: 31			
Product Profile	Virtual indicator	VI setup	Note
PP06 – ECR fixed dimmer Group: Local	VI003 +/-45 degrees forward bridge indicator	VS02 RTC / TPDO	This XDi will receive data directly from RTC 600 via CAN bus 1

XDi indicator no. 2 – Engine room			
Node ID: 31			
Product Profile	Virtual indicator	VI setup	Note
PP06 – ECR fixed dimmer Group: Local	VI003 +/-45 degrees forward bridge indicator	VS02 RTC / TPDO	This XDi will receive data directly from RTC 600 via CAN bus 1**

XDi indicator no. 3 – AFT bridge			
Node ID: 32			
Product Profile	Virtual indicator	VI setup	Note
PP01 – Front dimmer / XDi-net Dimmer group 1*	VI004 +/-45 degrees aft bridge indicator	VS02 RTC / TPDO	This XDi will receive data directly from RTC 600 via CAN bus 1

XDi indicator no. 4 – Centre console (Forward bridge)			
Node ID: 33			
Product Profile	Virtual indicator	VI setup	Note
PP02 – Analogue dimmer. Dimmer level is shared on CAN 1 and CAN 2 for dimmer group 1*	VI003 +/-45 degrees forward bridge indicator	VS02 RTC / TPDO	This XDi will receive data directly from RTC 600 via CAN bus 1**

XDi indicator no. 5 – Overhead panel (Forward bridge)			
Node ID: 34			
Product Profile	Virtual indicator	VI setup	Note
PP01 – Front dimmer / XDi-net Dimmer group 1*	VI003 +/-45 degrees forward bridge indicator	VS02 RTC / TPDO	This XDi will receive data directly from RTC 600 via CAN bus 1**

XDi indicator no. 6 – Bridge wing Portside (Forward bridge)			
Node ID: 34			
Product Profile	Virtual indicator	VI setup	Note
PP01 – Front dimmer / XDi-net Dimmer group 1*	VI003 +/-45 degrees forward bridge indicator	VS02 RTC / TPDO	This XDi will receive data directly from RTC 600 via CAN bus 1**

XDi indicator no. 7 – Bridge wing Starboard (Forward bridge)			
Node ID: 34			
Product Profile	Virtual indicator	VI setup	Note
PP01 – Front dimmer / XDi-net Dimmer group 1*	VI003 +/-45 degrees forward bridge indicator	VS02 RTC / TPDO	This XDi will receive data directly from RTC 600 via CAN bus 1**

**\*Note** Select another product profile (PP) if you want to use another type of dimmer input. See **Appendix 3** for more details.

See **Appendix 1** for the detailed first-time setup procedure.

**\*\*NOTE** The RTC angle transmitter can be connected to either CAN 1 or CAN 2. Adjustment of the rudder zero, min. and max. angle can be made from any of the XDi units in the system and can be synchronised with all other XDi indicators in the system. (See detailed description later in this section)

### Commanded rudder presentation on XDi

All the standard XDi rudder indicators have a small triangle pointer and an orange digital readout showing the commanded rudder angle.

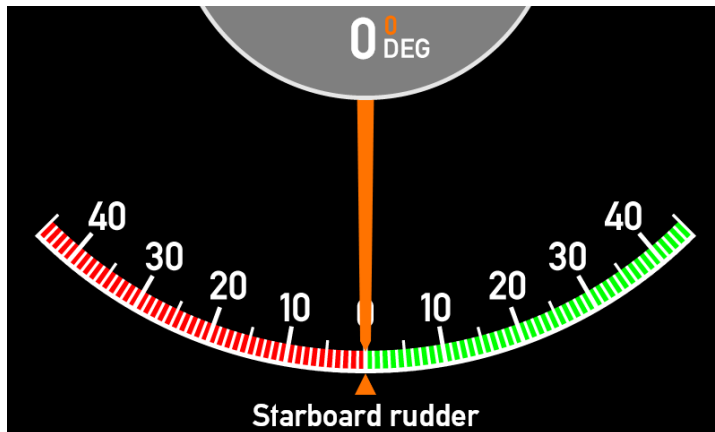

In this example the XDi system can receive the commanded rudder angle via CAN either in a TPDO with COB-ID 0x1A1 (Byte 0 and 1: value +/-1800) or via XDi-net format.

If the VI-setup profile VS03 is used instead of VS02, then an analogue 4-20 mA signal connected to an AX1 module on the XDi, for example, in the steering gear room (XDi 1) can be received and shared on CAN using XDi-net. The other indicators use profile VS02 as before. XDi 1 scales the input and distributes it automatically via XDi-net (CAN) to the other XDi units in the system.

#### Disabling commanded rudder indication

If you don't want to use the commanded rudder indication, it can be disabled.

See **Appendix 5** for more information about disabling commanded rudder indication.

#### Installation and calibration of the rudder system

The system can be calibrated after it is installed on-board and the XDi indicators are setup according to the previous chapters.

#### Example

In this example, the max rudder movement is 41.0° to portside from zero and 39.5° to starboard.

#### Calibrate the angle transmitter

The angle transmitter does not need any physical zero alignment, it is easily done after installation.

#### Calibrating steps:

##### Step 1 – Zero set.

Simply position the rudder in its zero position and follow the zero set procedure in the quick installation guide. Connect brown and white wire together to the blue wire (0 V) for 5 s and release them. Zero is set and you will see that the rudder indicators all go to 0 degree.

If the RTC angle transmitter is connected to the rudder 1:1, so that 20° rudder angle equals a 20° rotation of the RTC shaft, the XDi default input scaling parameters will be correct and no further adjustment is needed.

##### Step 2 – Starboard angle verification (max.)

Position the rudder in the utmost starboard position, check that the rudder angle indication on the XDi display is showing the correct SB rudder angle.

If the angle is not correct, change it as shown in step 4. In this example the actual physical rudder angle is 39,5° SB and the angle value presented on XDi is 41,5° SB.

##### Step 3 – Portside angle verification (min.)

Position the rudder in the utmost portside position, check that the rudder angle indication on the XDi display is showing the correct PS rudder angle.

If the angle is not correct, change it as shown in step 4. In this example the actual physical rudder angle is 41.0° PS and the angle value presented on XDi is 43° PS.

#### Step 4 – Rescale the rudder angle input

Press button 1 and 4 at the same time for 5 sec to open the User menu.

Press button 2 and 3 at the same time for 5 sec to open the installation menu.

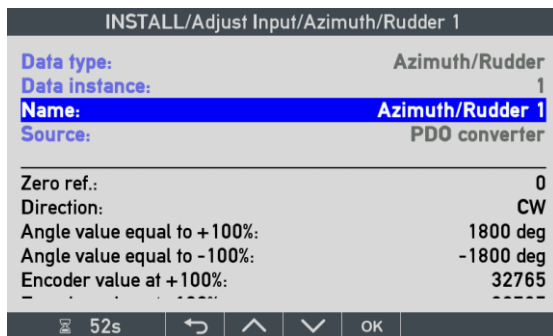
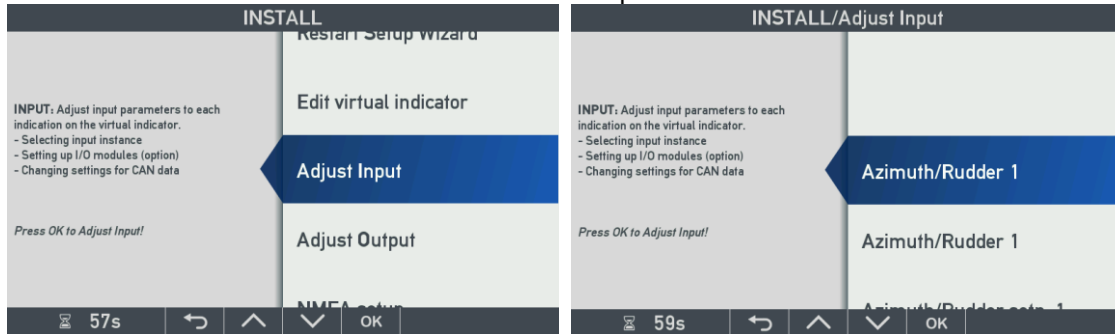

Make the above selections to enter the Azimuth/Rudder input adjust menu.

You can now set a new zero reference, but since the RTC is already calibrated it will not be necessary.

The relative angle value from the RTC is equal to 182.04 per degree, XDi was showing 41.5° when the rudder was in outmost SB position, but in that position the actual rudder angle was determined to be only 39.5°, so the SB position shall be calibrated. The easiest is to make a new set of input scaling parameters. Angle value +100% shall be changed to 39.5° with 0.1 internal resolution this means 395 and the Encoder value from RTC shall be changed to the value received in the SB rudder end point. It is in fact the value 7555 ( $7555/182.04 = 41.5$ )

Scroll down to “Angle value equal to +100%” in the menu and push the OK button, to be able to change this value to the new max. rudder angle  $\times 10 = 395$ .

INSTALL/Adjust Input/Azimuth/Rudder 1	
Zero ref.:	0
Direction:	CW
Angle value equal to +100%:	1800 deg
Angle value equal to -100%:	-1800 deg
Encoder value at +100%:	32765
Encoder value at -100%:	-32765
----- Advanced -----	
Conversion mode:	CAN1&CAN2 ON
Encoder TPDO/RPDO:	0x0181
PDO data format:	Signed
56s	← ↑ ↓ OK

**Note:** XDi is able to calculate both a % and an actual angle value. In the rudder indicator only actual angle value is used.

INSTALL/Adjust Input/Azimuth/Rudder 1	
Choose a value:	
min. -32768	+00395
max. 65535	
54s	← ↑ ← OK

Press OK to save the new value.

INSTALL/Adjust Input/Azimuth/Rudder 1	
-----	
Zero ref.:	0
Direction:	CW
Angle value equal to +100%:	395 deg
Angle value equal to -100%:	-1800 deg
Encoder value at +100%:	32765
Encoder value at -100%:	-32765
----- Advanced -----	
Conversion mode:	CAN1&CAN2 ON
Encoder TPDO/RPDO:	0x0181
57s	← ↑ ↓ OK

Next the step is to set the Encoder value equal to 100%.

INSTALL/Adjust Input/Azimuth/Rudder 1	
Zero ref.:	0
Direction:	CW
Angle value equal to +100%:	395 deg
Angle value equal to -100%:	-1800 deg
Encoder value at +100%:	32765
Encoder value at -100%:	-32765
----- Advanced -----	
Conversion mode:	CAN1&CAN2 ON
Encoder TPDO/RPDO:	0x0181
51s	OK

Press OK to open for editing.

The rudder is still in the max. SB position and the actual RTC angle transmitter value can be seen to the left of the parameter value. In this case it is 7555. This value should now be entered into the parameter window.

(Due to the limited number of buttons there is unfortunately not a single push function to enter the actual encoder value, you must enter it manually)

INSTALL/Adjust Input/Azimuth/Rudder 1	
Choose a value:	Actual: 7555
min. -32768	+ 0 7 5 5 5
	max. 65535
58s	OK

Press OK to save the new value.

INSTALL/Adjust Input/Azimuth/Rudder 1	
Zero ref.:	0
Direction:	CW
Angle value equal to +100%:	395 deg
Angle value equal to -100%:	-1800 deg
Encoder value at +100%:	7555
Encoder value at -100%:	-32765
----- Advanced -----	
Conversion mode:	CAN1&CAN2 ON
Encoder TPDO/RPDO:	0x0181
PDO data format:	Signed
48s	OK

Now the SB side is calibrated.

But the Portside is also slightly misaligned, so it must also be calibrated. The max. PS rudder angle is  $-41.0^\circ$  and with the default setup XDi shows  $-43.0^\circ$ , this means that the value from the RTC angle transmitter is  $-43.0 \times 182.04 = -7828$ .

Now change "Angle value equal to -100%" to  $-410 (=41.0^\circ)$  and change the Encoder value at -100% to  $-7828$ .

INSTALL/Adjust Input/Azimuth/Rudder 1

Choose a value: **-07828** Actual: -7828  
min. -32768 max. 65535

53s [Back] [Up] [Down] [OK]

The actual value from the RTC angle transmitter for the rudder in its max. SB position. Press OK to save the new value.

INSTALL/Adjust Input/Azimuth/Rudder 1

Zero ref.: 0  
Direction: CW  
Angle value equal to +100%: 395 deg  
Angle value equal to -100%: -410 deg  
Encoder value at +100%: 7555  
**Encoder value at -100%: -7828**

----- Advanced -----  
Conversion mode: CAN1&CAN2 ON  
Encoder TPDO/RPDO: 0x0181

50s [Back] [Up] [Down] [OK]

Now the calibration is completed for this XDi unit.

When you push  then a new menu will be shown:

INSTALL / ... / Select

Synchronize parameter change on network?

NO  
**YES**

57s [Back] [Up] [Down] [OK]

Make sure that all XDi indicators in the rudder system are powered up and then select “YES” to synchronise parameters on the network. All the other XDi indicators in the system will now receive the new parameter settings for the scaling of the RTC angle transmitter CAN data.

Now the system is using data directly from the RTC angle transmitter and it is scaled to show the correct rudder angle, with a very high accuracy.

Outmost starboard rudder 39.5°

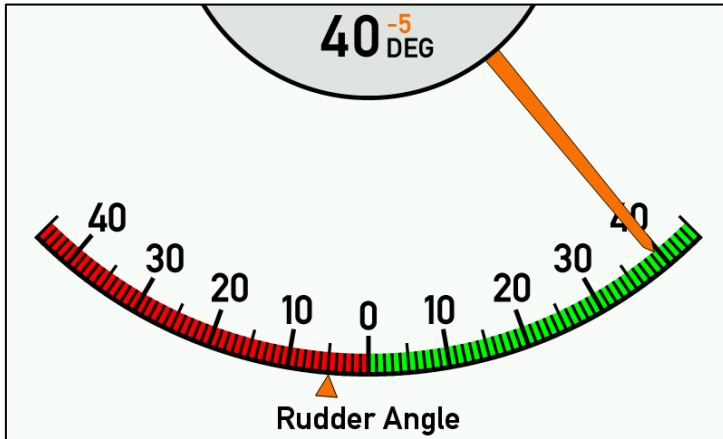

Outmost portside rudder position 41.0°

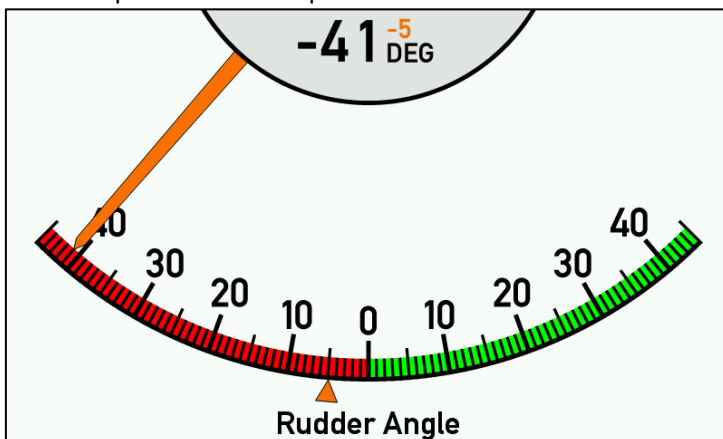

#### If the pointer turns the wrong way

Before you start the calibration process you should check if the pointer is moving in the right direction. If it is moving in the wrong direction you should change “Direction” from the default CW to CCW.

INSTALL/Adjust Input/Azimuth/Rudder 1	
Source:	PDO converter
Zero ref.:	0
Direction:	CCW
Angle value equal to +100%:	395 deg
Angle value equal to -100%:	-410 deg
Encoder value at +100%:	7555
Encoder value at -100%:	-7828
----- Advanced -----	
Conversion mode:	CAN1&CAN2 ON
54s	↶ ↷ OK

It is important that you do it before making the calibration because the scaling parameters will be overwritten by the default values.

Be aware that in CCW mode the -100% scaling parameters will now scale Starboard angle values and +100% scaling parameters will now scale the Portside angle values. (CCW equals a multiplication of the output value by -1 before it is used or shared on CAN.)

The result of the CCW setup above with input value +7555, the pointer shows PS 39.5°

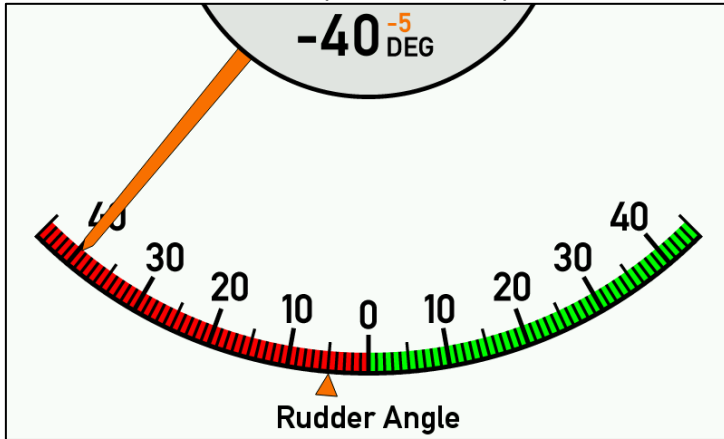

The result of the CCW setup above with input value -7828, the pointer shows PS 41.0°

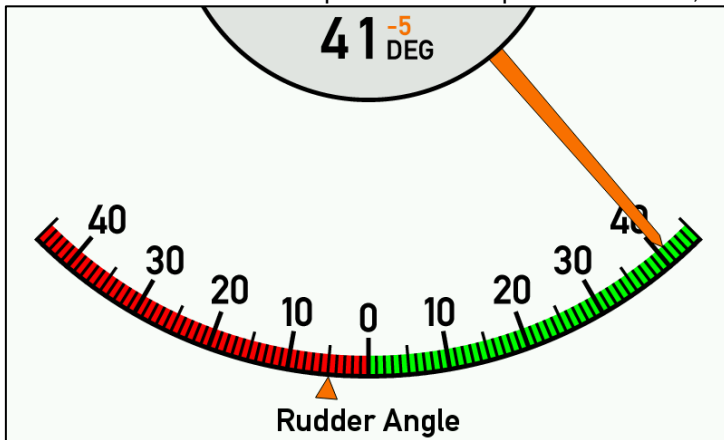

Also, in this case you shall remember to select "YES" to synchronize the parameters in the system. All XDi indicators will then be aligned and will all use CCW when angle data from RTC is scaled.

**CAN system 4.2 – Combined XDi and XL indicators with sCAN interface**

It is possible to make a full CAN bus rudder indicator system where XDi and traditional mechanical indicators are mixed. This fully digital system offers very high accuracy and reliability. It is even possible to build some degree of redundancy into the system.

This solution can for example be used in applications where very robust BW or BRW-2 outdoor indicators are needed. BW and BRW-2 provide superior viewing ability in bright sunlight conditions, where display-based indicators are challenged. The solution can also be used where there is a need for a large panorama type indicator mounted on the ceiling.

The menu system in the XDi units makes it easy to setup and calibrate the complete system. All calibration can be done from any one of the XDi units.

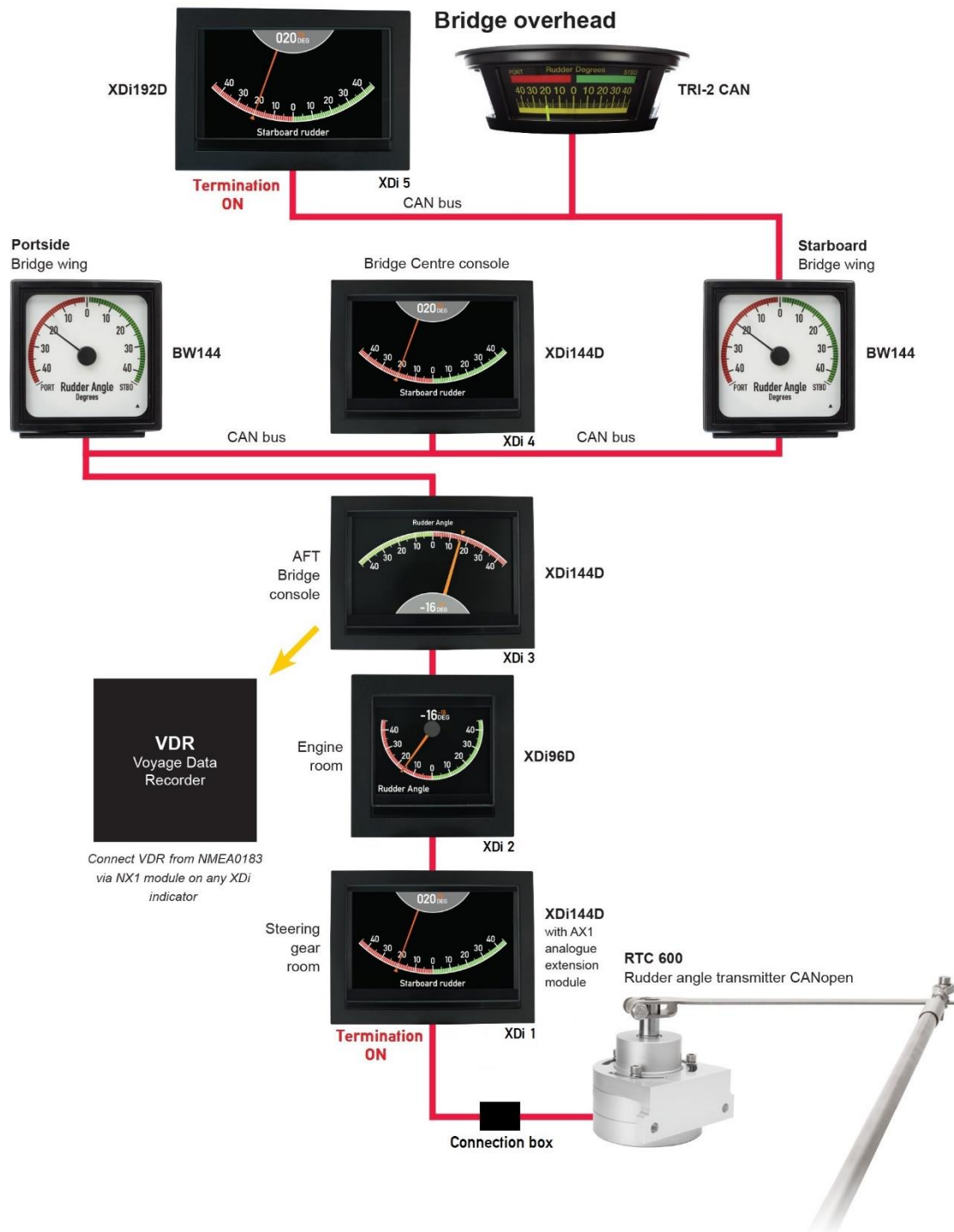

All the XDi indicators receive CAN data directly form the angle transmitter.

One XDi indicator is setup to transmit the correct scaled rudder angle values via CAN bus to all the traditional indicators in the system. This indicator is both a rudder indicator and a converter box. Using an XDi as converter box is just a digital converter solution, similar to using the TDG-210 amplifier to convert a 4-20 mA to a +/-10 V signal in System application 2.

The actual rudder angle value is sent in TPDO1 (Default 0x18A) as a signed 16-bit value to all the traditional indicators, such as: XL, BW, BRW-2 and/or TRI-2 CAN. Note that the indicator must be ordered preconfigured with sCAN ID = 10 (This means that data is received in TPDO1, COB-

ID 0x18A).

The installation menu system in any of the XDi units in this system can be used to calibrate the rudder system and synchronise the calibration data with all other XDi units.

Using XDi in this way makes calibration of the complete system very easy.

### Connecting the RTC CAN angle transmitter to the indicators

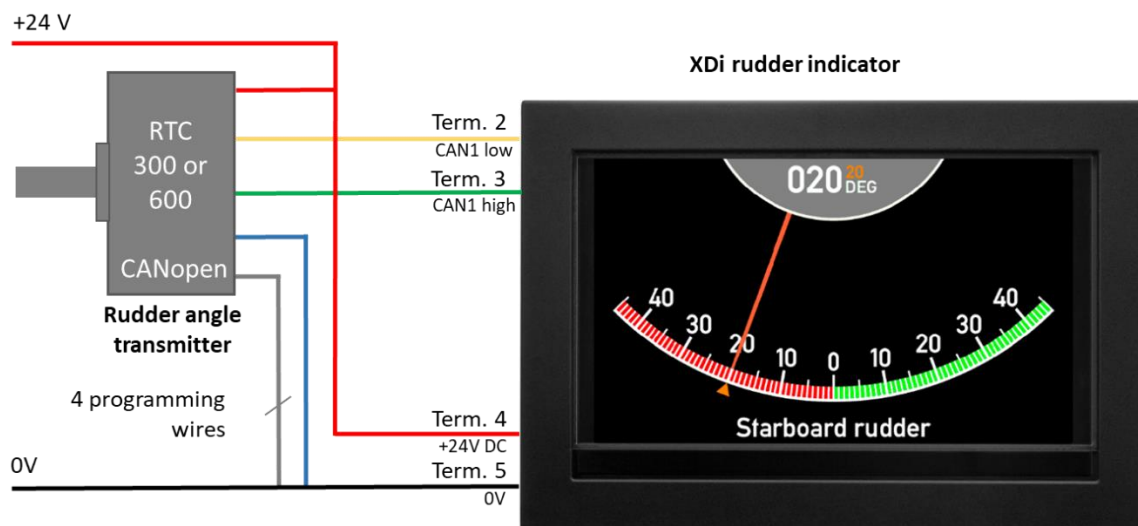

### Connecting RTC to XDi via CAN bus 1

RTC 300 or RTC 600 CAN rudder transmitter	Function		XDi 1 term.	Power supply
Blue wire	Supply voltage	-	5	0 V
Red wire		+	4	+ 24 V DC
Green	CAN	High	3	
Yellow		Low	2	
Shield	Electrical shielding of data signal cable		No connection	
White Grey Pink Brown	Programming wires After programming connect all to 0 V (blue wire)		(5)	0 V

### CAN system connections

Function		XDi 1 term.	XDi 2 term.	XDi 3 term.	BRW-2 term.	XDi 4 term.	BRW-2 term.	TRI-2 term.	XDi 5 term.	Power supply
Supply voltage	-	5	5	5	-	5	-	2	5	0 V
	+	4	4	4	+	4	+	1	4	+ 24 V DC
CAN 1 Low		2	2	2	84	2	84	8	2	
CAN 1 High		3	3	3	83	3	83	7	3	
CAN cable shield	Connected between cables, but no connection to the indicators									
CAN 1 termination		ON*	OFF	OFF	OFF	OFF	OFF	OFF	ON	

**\*Note** CAN bus termination: If the CAN bus cable between the RTC 600 and XDi 1 is more than 10 meters, it is recommended to mount a 120 Ω termination resistor (supplied with RTC 600) closer to RTC 600. The resistor is supplied with RTC 600 shall be mounted between CAN high and CAN low. A good place to locate this resistor is in the installation box where the pigtail cable from RTC600 is joined with the CAN backbone cable coming from XDi 1. In this case

don't activate the termination resistor in XDi 1.

### CAN bus termination

It is very important to terminate the CAN bus in both ends, failing to do so will result in unreliable CAN bus operation.

In this example an XDi is located in both endpoints of the CAN bus. Activate the internal CAN bus termination resistor in the XDi units located in both ends of the CAN bus. See table above.

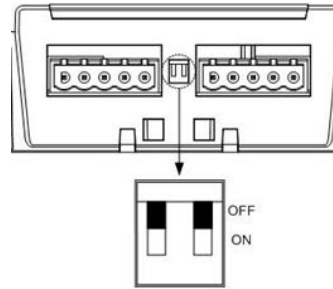
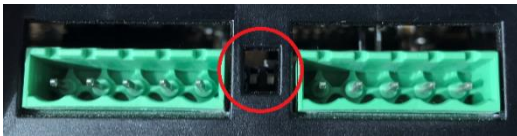

### Dimming of an XDi system.

The XDi indicators offer a wide range of dimmer control options:

- CAN bus
- External voltage dimmer input
- External potentiometer connection
- External pushbuttons
- Buttons on the XDi front (optional)

All external dimming functions, except dimming via CAN bus, requires the use of an extension module.

The front button dimmer control on XDi requires the four-button front frame option or accessory kit, available as accessory, and the XDi library must be version 2000 or higher. The DEIF standard rudder indicator libraries support this function.

An XDi unit with external or front dimmer control can share the dimmer level via XDi-net (CAN bus) for a group of XDi indicators connected to the same CAN bus.

In installations with a number of separate indicator systems it can be beneficial to use CAN bus 2 as a dimmer control bus. This way several independent indicator systems can be interconnected without jeopardising the system separation. This is possible due to the galvanic separation of the two CAN busses.

It is possible to control dimming via CAN and divide the system into dimmer groups (max. 9 groups). Dimmer groups are independent of the selected dimming input type. XDi 3 to XDi 7 can for example be controlled as one group. The default is dimmer group 1.

One of the indicators controlled by a dimmer potentiometer (AX1 module required) controls all units in the group. Dimming can also be controlled via the front button on one or more XDi indicators in the group. (Front button option or kit is required.)

In this example dimmer group 1 is controlled via a potentiometer connected to an AX1 module on XDi 4.

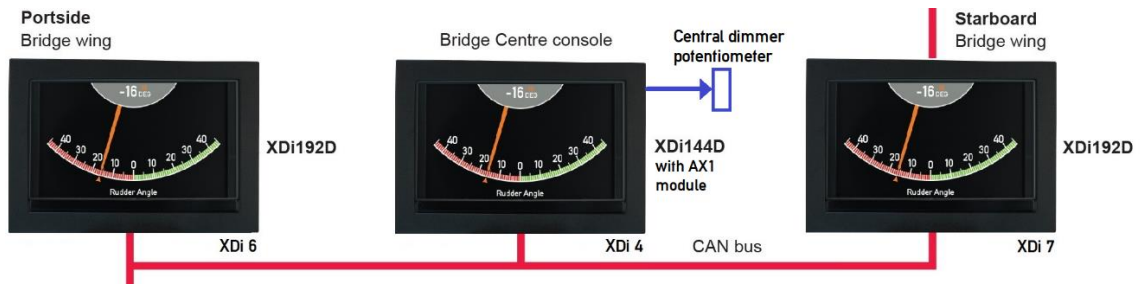

For the XDi units located in the steering gear room and engine control room, a fixed dimmer level and dimmer group “Local” is often used. “Local” means that dimming is not controlled via the CAN bus.

Note that the default dimmer group 1 for most of the product profiles, except for the ECR profile that has a fixed dimmer level and is pre-set to “Local”.

See **Appendix 3** for a description of the different dimmer alternatives.

**Installation setting**

Order the XDi unit with the DEIF standard rudder library 031. This library contains a selection of virtual rudder indicators.

The library contains indicators with standard scales for  $\pm 40^\circ$ ,  $\pm 45^\circ$ ,  $\pm 50^\circ$ ,  $\pm 70^\circ$  and for use on respectively a forward or aft pointing bridge.

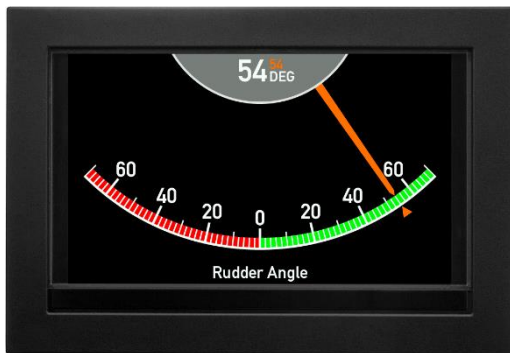

Rudder angle indicator  $\pm 70^\circ$  forward (VI007)



Rudder angle indicator  $\pm 45^\circ$  aft (VI004)



Example of XDi 96 D scale configured to  $\pm 30^\circ$

Contact DEIF if the rudder scale you need is not in the standard library. The scale may already be added or is in the process of being added.

It is possible to have a unique customised indicator design. XDi is made for easy customisation of indicators.

### Installation wizard

If the XDi is not set up, it will automatically open the start-up wizard.

The correct XDi setup for this system example is shown in the tables below.

#### Select the CAN NodeID.

In this application all XDi units receive the angle value directly from the RTC 600 CAN angle transmitter that by default has NodeID 1. The transmitter transmits angle data as a 16-bit value in byte 0 and 1 in TPDO1 with COB-ID 0x181.

All XDi units on the CAN bus must have different CAN NodeID. Each XDi unit must have a unique ID. The suggested CAN node IDs are found in the tables below.

The XL, BW, BRW and TRI-2 indicators are all single CAN (sCAN) indicators and are listen only devices. This means that they don't have a NodeID on the CAN bus. The sCAN ID for the indicator refers to the source of the CAN data this unit will read, not the node ID for the unit. The TPDO that such an indicator is listening for is a TPDO1, COB-ID 0x180 + sCAN ID.

The example system uses the DEIF standard rudder indicator library no. 031 and the rudder indicator selected should be +/-45°.

XDi indicator no. 1 - Steering gear room (including analogue to CAN bus conversion)			
Node ID: 31			
Product Profile	Virtual indicator	VI setup	Note
PP06 – ECR fixed dimmer Group: Local	VI003 +/-45 degrees forward bridge indicator	VS02 RTC / TPDO	This XDi will receive data directly from RTC 600 via CAN bus 1**

XDi indicator no. 2 – Engine room			
Node ID: 31			
Product Profile	Virtual indicator	VI setup	Note
PP06 – ECR fixed dimmer Group: Local	VI003 +/-45 degrees forward bridge indicator	VS02 RTC / TPDO	This XDi will receive data directly from RTC 600 via CAN bus 1**

XDi indicator no. 3 – AFT bridge			
Node ID: 32			
Product Profile	Virtual indicator	VI setup	Note
PP01 – Front dimmer / XDi-net Dimmer group 1*	VI004 +/-45 degrees aft bridge indicator	VS02 RTC / TPDO	This XDi will receive data directly from RTC 600 via CAN bus 1**

XDi indicator no. 4 – Centre console (Forward bridge)			
Node ID: 33			
Product Profile	Virtual indicator	VI setup	Note
PP02 – Analogue dimmer. Dimmer level is shared on CAN 1 and CAN 2 for dimmer group 1*	VI003 +/-45 degrees forward bridge indicator	VS02 RTC / TPDO	This XDi will receive data directly from RTC 600 via CAN bus 1**

XDi indicator no. 5 – Overhead panel (Forward bridge)			
Node ID: 34			
Product Profile	Virtual indicator	VI setup	Note
PP01 – Front dimmer / XDi-net Dimmer group 1*	VI003 +/-45 degrees forward bridge indicator	VS02 RTC / TPDO	This XDi will receive data directly from RTC 600 via CAN bus 1**

**\*Note** Select another product profile (PP) if you want to use another type of dimmer input. See

**Appendix 3** for more details.

See **Appendix 1** for more information about the first-time setup procedure.

**\*\*Note** The RTC angle transmitter can be connected to either CAN 1 or CAN 2. Adjustment of the rudder zero, min. and max. angle can be made from any of the XDi units in the system and can be synchronised with all other XDi indicators in the system. (See detailed description later in this section.)

No setup is required for:

BW 144 indicator – Bridge wing Portside (Forward bridge)
sCAN ID: 10

BW 144 indicator – Bridge wing Starboard (Forward bridge)
sCAN ID: 10

TRI-2 CAN Panorama indicator – Sealing (Forward bridge)
sCAN ID: 10

### Activation of the CAN signal to the traditional indicators

The traditional XL, BW, BRW and TRI indicators receive angle data from one of the XDi indicators.

XDi 1 is used as the CAN converter unit. It receives the relative 16-bit value and scales it to an absolute angle value before it is retransmitted to the traditional indicators.

To activate the transmission of CAN data, enter the installation menu on XDi 1 (Steering gear room) by pushing button 1 and 4 at the same time for 5 s to enter the user menu. Then push button 2 and 3 at the same time for 5 s to enter the installation menu:

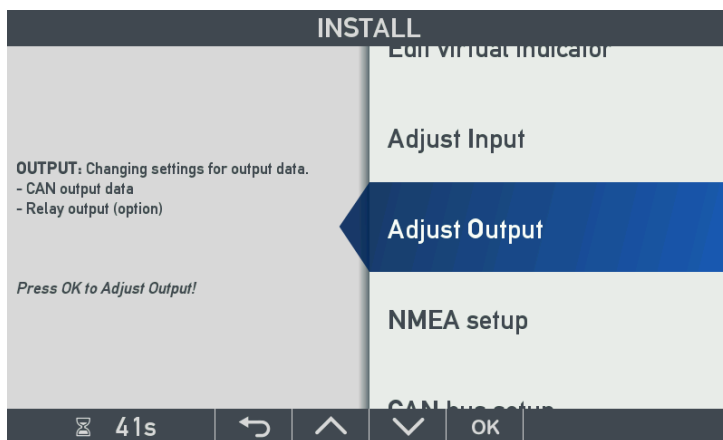

Highlight “Adjust output” and press OK.

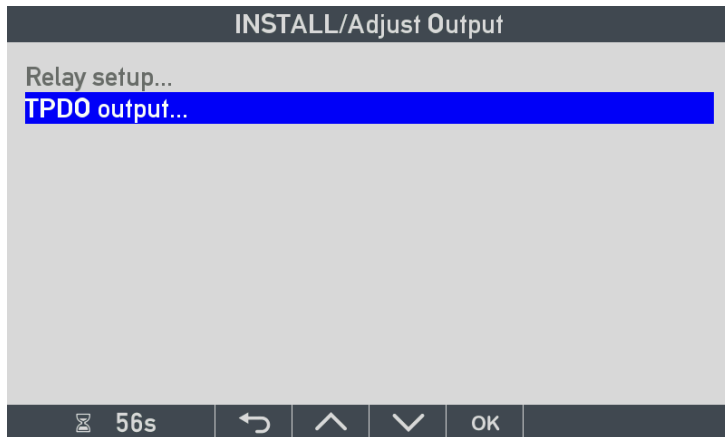

Because rudder angle is transmitted in a TPDO, highlight “TPDO output...” and press OK.

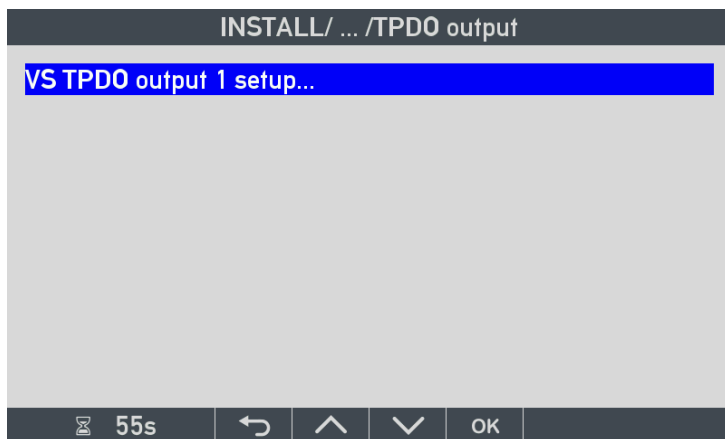

All rudder angle indicators in the standard rudder library has a VS02 profile that is prepared for transmission of the actual rudder angle value. In this case there is only one TPDO output defined. Press OK.

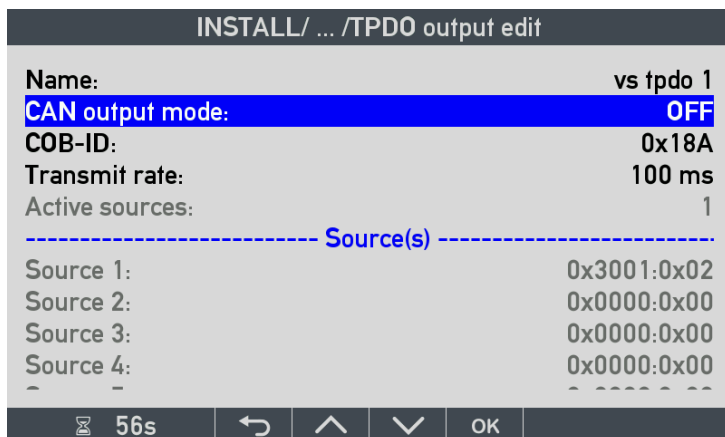

The TPDO output is disabled by default. The CAN output mode is OFF. Highlight “CAN output mode” and press OK.

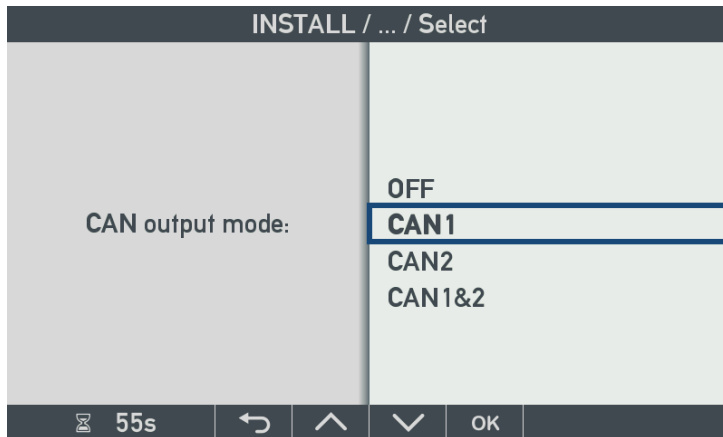

Select CAN1 and press OK.

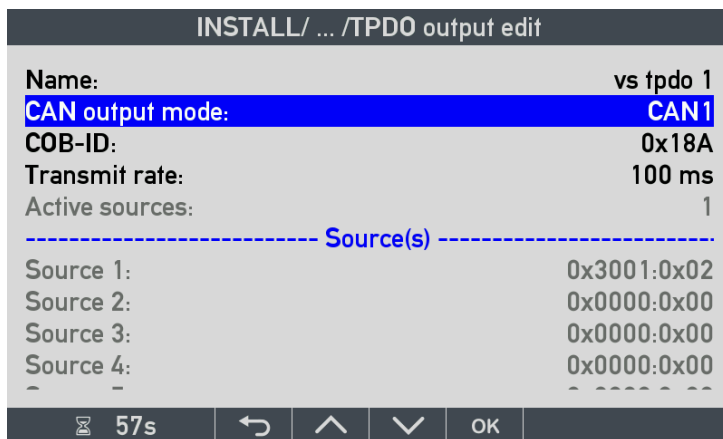

It is possible to change the repetition rate of the TPDO. In this example the 100 ms default is used.

The rudder angle is sent in TPDO with COBID 0x18A (0x180 + sCAN ID 10, (Decimal 10 = Hex 0xA)) by default. It is possible to change the TPDO that is used for the transmission.

### Fault handling in the system

In all rudder indicator systems, there is a fault scenario that makes the entire system fail.

For example, if the angle transmitter fails or the cable from the transmitter is damaged, then the entire system fails. In this system one XDi is acting like a CAN converter between the sensor and the traditional indicators, so if this indicator fails all the traditional indicators are lost.

If this happens it is possible for a skilled person on-board to disconnect the faulty XDi unit from the system and then change the Output setup on any other XDi in the system to take over transmitting the TPDO with actual rudder angle data. Follow the above procedure to activate the TPDO on CAN1.

### Commanded rudder presentation on XDi

All the standard XDi rudder indicators have a small triangle pointer and an orange digital readout showing the commanded rudder angle.

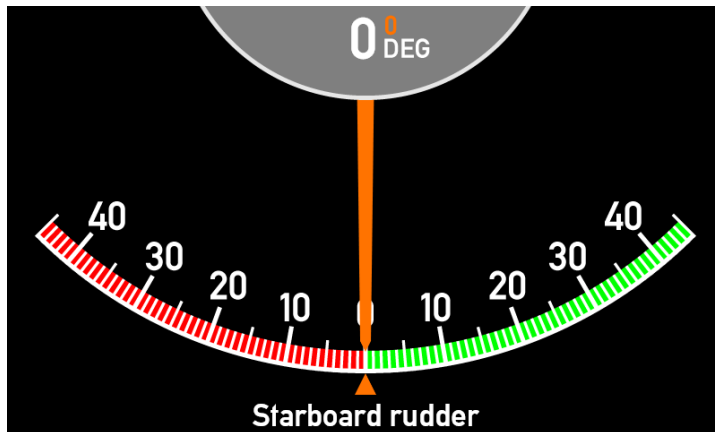

See **Commanded rudder presentation on XDi** in **System application 3** for more information about using this function and how to disable it.

#### **BRW-2, BW144/192 or XL configuration**

The traditional indicators (BRW-2, BW or XL) used in this rudder system, must be ordered with single CAN input (sCAN). XL sCAN is a listen only device on the CAN bus.

The XL type indicators in the example system have the following configuration:

Input:	Single CAN
Source NodeID:	10 (Data is sent from XDi in CAN TPDO1 with COB-ID: 0x18A)
Application type:	General
Input type:	Absolute (16-bit signed, rudder angle value x 10 (Resolution 0.1))
Input min.	-450 (equal to -45.0° PS, this must match the min. scale value)
Input centre	0
Input max.	+450 (equal to +45.0° SB, this must match the max. scale value)

See **BRW-2, BW144/192 or XL configuration** in **System application 3** for more information about the traditional indicator configuration.

#### **TRI-2 CAN configuration**

TRI-2 is available in a special CAN version, TRI-2 CAN.

Order number: 2951460020 variant 02

The TRI-2 CAN in the system application example has the following configuration:

Input type:	Single CAN from XDi as transmitter
Source NodeID:	10 (CAN data is sourced in CAN TPDO1 with COB-ID 0x18A)
Select standard scale:	+/-45 red/green

See **TRI-2 CAN configuration** in **System application 3** for more information about the traditional indicator configuration.

#### **Installation and calibration of the rudder system**

The system can be calibrated after it is installed on-board and the XDi indicators are setup according to the previous chapters.

#### **Calibrating steps**

See **System application 4 > CAN system 4.1 > Example** for more information about how to calibrate the rudder system. The calibration procedure of this system application is the same as the calibration procedure for system application 4.1.

To calibrate the entire system, calibrate one XDi and synchronise the calibration date with the rest of the system. All the traditional indicators are setup and calibrated from factory to show the actual rudder angle, and require no further calibration.

### System application 5 – 3-wire rudder indicator system (Not MED)

XDi Dual with DEIF standard rudder library number 031 (Lib. owner 1) contains an indicator setup profile (for XDi144 and 192 D it is VS09) specifically for 3-wire rudder system applications.

Due to the flexibility of the XDi this solution is attractive for retrofit and service projects.



**DEIF does not have a 3-wire feedback unit and therefore this solution is not included on the MED certificate.**

#### 5.1 Analogue 3-wire system

##### Rudder indicators

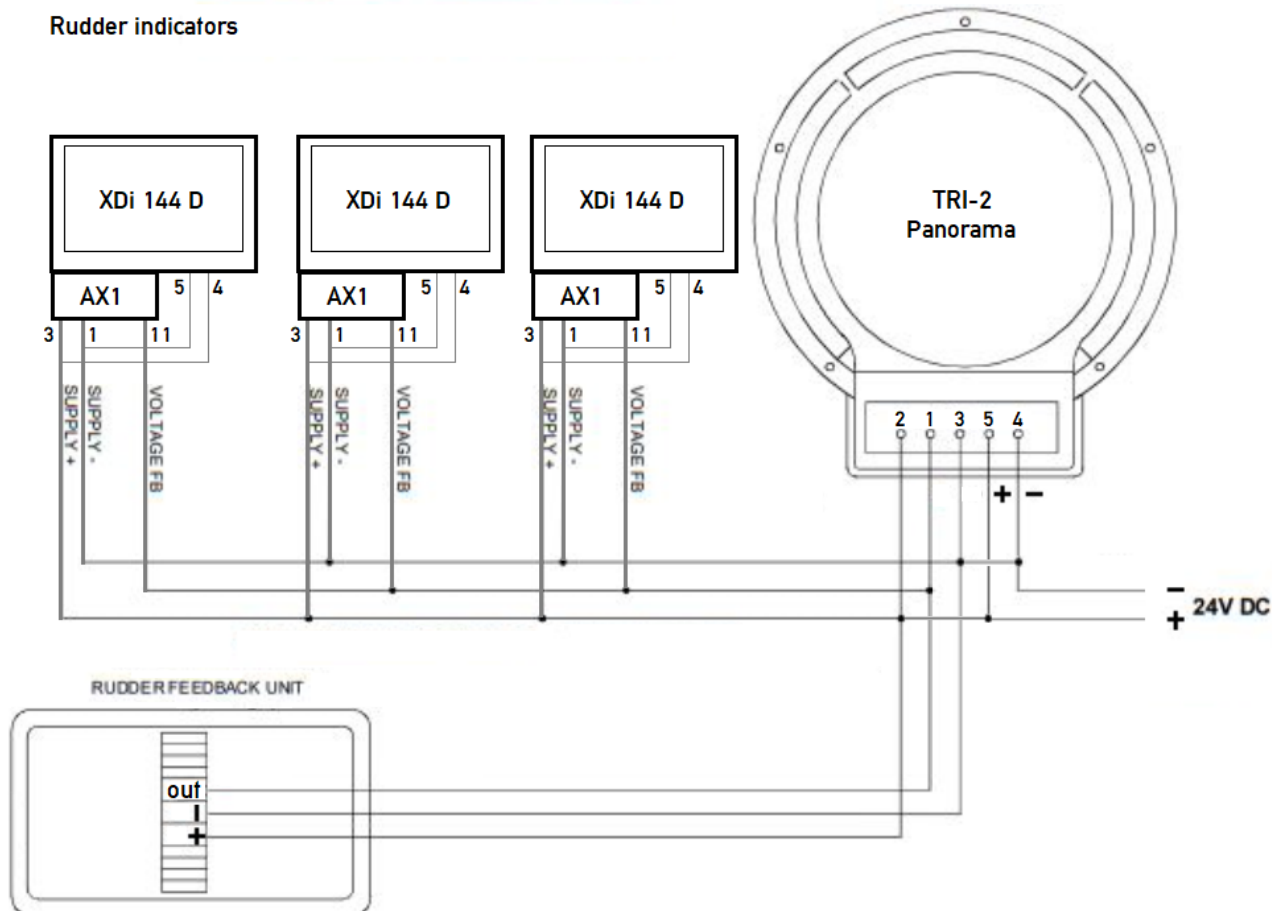

For outdoor use a BRW-2 rudder indicator with white scale is recommended. The BRW-2 is available with a 3-wire input.

##### XDi 144 D unit

The power supply input is on terminal 4 (+24 V) and terminal 5 (0 V). The typical current consumption at 24 V and 100 % backlight is 160 mA, with an absolute max. of 200 mA.

##### AX1 module

Terminal 1: Analogue ground

Terminal 3:  $V_{ref}$  output that in this system is overwritten by the 24 V supply voltage. ( $V_{ref}$  is approximately 7.3 V DC. This means that the external voltage must be >7.3 V and max. 30 V)

Terminal 11: + high voltage input 1 (max. +/-30 V DC)

### XDi 144 D setup

For a 45° rudder indicator (FWD type) select VI03 and VS09 (3-wire input profile).

### Calibration of the rudder input

The selected VS profile is setup to match a system with a 24 V supply and +/-9 V voltage swing around half supply (12V). In this system it may be necessary to calibrate each indicator separately to get an accurate zero and min./max. rudder angle setting. This is done with the XDi installation menu.

See **Calibrating the rudder input via XDi menu in a 3-wire system** for more information about the calibration process.

Due to the high accuracy of the inputs on the AX1 analogue extension module, the calibration parameters can be used to calibrate the remaining units. Calibrate the first XDi to match the rudder angle in three positions. Then use the same calibration parameters for the remaining XDi indicators in the system.

### 5.2 CAN and Analogue 3-wire input

The configuration in this example uses CAN bus and the XDi-net Plug and Play protocol to reduce the system calibration effort. A TRI-2 CAN is added to the system for this example. Alternatively, replace the TRI-2 CAN with an XL, BW or BRW-2 with sCAN.

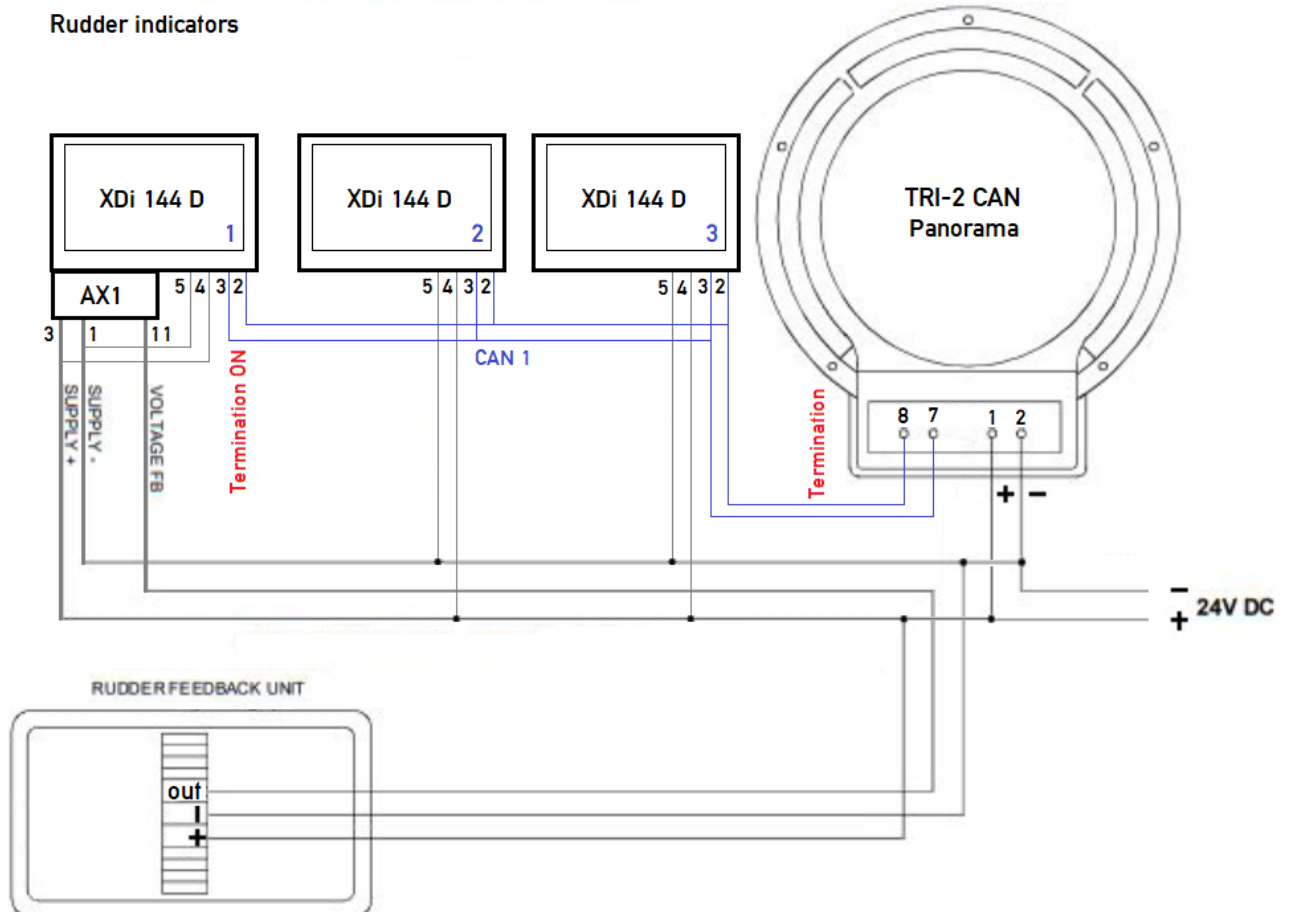

Remember to terminate the bus in both ends with a 120  $\Omega$  resistor when using CAN bus. The build in termination resistor can be activated by a switch located between the Power/CAN connectors.

If the TRI-2 CAN is connected as the last unit on the bus, the internal termination on CAN1 shall be activated.

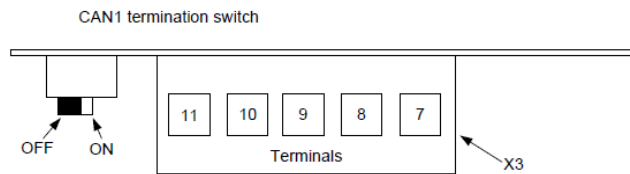

### TRI-2 configuration

TRI-2 CAN with the input type “Single CAN from XDi as transmitter” with CAN ID 10.

The CAN input is pre-configured to the selected scale angle. This means that no other setup or calibration is required.

### XDi 144 D setup

XDi Dual with DEIF standard rudder library no. 31 (Owner 1).

After the unit is installed a setup wizard starts when the unit is powered up. Follow the steps in the wizard to finish the setup and calibration. See **Appendix 1** for more information.

For a 45° rudder indicator (FWD type):

- Select VI03 and VS09 (3-wire input profile) for XDi 1
- Select VI03 and VS01 (XDi-net) for XDi 2

### Calibration of the rudder input

The selected VS09 profile is setup to match a system with 24 V supply and +/-9 V voltage swing around half supply (12 V). Only XDi 1 needs to be calibrated to the accurate zero and min./max. rudder angle setting in this system.

See **Calibrating the rudder input via XDi menu in a 3-wire system** for more information about the calibration process.

XDi 2, XDi 3 and the Tri-2 CAN automatically receive the angle data via XDi-net. No additional setup is required. You can add up to 50 indicators on the CAN bus.



### IMPORTANT!

If previous calibration attempts were unsuccessful, a master-reset of the unit can be made to start a new calibration process.

### Disabling the commanded rudder presentation

If you don't want to use the commanded rudder indication, it can be disabled.

See **Appendix 5** for more information about disabling commanded rudder indication.

### XDi dimming

The dimmer signals are not shown on the system application diagram.

The XDi can be dimmed using the following methods:

- Using the front buttons
  - Select PP01 and order XDi with the front button option
- Using external pushbuttons
  - Requires an NX1 input.
- Using an analogue dimmer potentiometer

- Select PP02 for dimmer gr.1 control via CAN or PP05 for local dimmer
- The potentiometer can be connected to terminal 1 (AGND), 2 (Wipster) and 3 (V<sub>ref</sub>) (in this case 24 V from the 3-wire supply)

The dimmer input can be reconfigured from potentiometer input to a normal voltage dimmer input through the XDi user menu. You can input a dimmer voltage between terminals 1 and 2 and scale this voltage to 0-100% dimmer level (100% = max. backlight).

See **Appendix 3** for more information.

**XDi first time setup**

When XDi is new and has not yet been setup for the first time it will automatically start a setup wizard, see appendix 1 for more details.

You will have to complete the 4 basic selections on each indicator to make it go into normal operation.

**Calibrating the rudder input via XDi menu in a 3-wire system**

The following description is for an analogue input calibration in a 3-wire configuration where V<sub>ref</sub> is overwritten by 24 V DC. The default input swing is +/-9 V around half supply (12 V). The input voltage varies between 3 and 21 V.

**Calibration of the rudder input**

When potentiometer input mode (3-wire) is used, the input signal on +HV<sub>in</sub> is scaled to a relative value between 0 and the measured V<sub>ref</sub>. The relative input value ranges from 0 (in=0 V) to 10000 (in=24 V).

Default 3-point rudder input calibration for a 45° indicator:

Potentiometer input parameters:					
PS		0		SB	
0 V	3 V	12 V		21 V	24 V
0	1250	5000		8750	10000
!	X	!		X	!
	-450	0		+450	
	(-45.0°)	0°		(+45.0°)	
<b>Default calibration</b>					
I/O point 1: PS 3.0 V = relative value 1250 = -450 (-45.0deg)					
I/O point 2: Ctr 12.0 V = relative value 5000 = 0 (0deg)					
I/O point 3: SB 21.0 V = relative value 8750 = 450 (+45.0deg)					

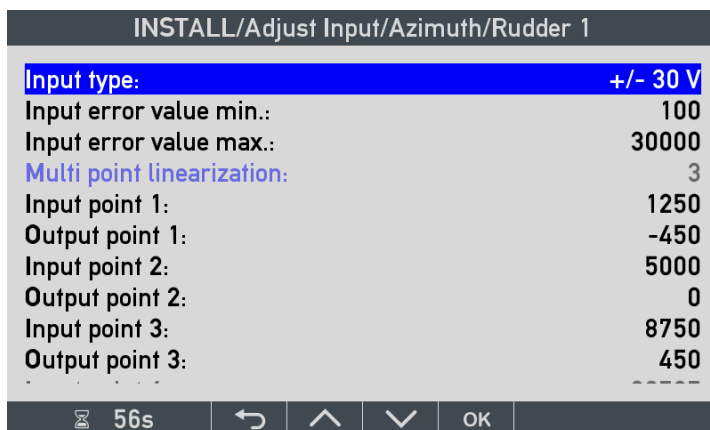



The input error band is set up to a minimum voltage of 100 mV and a maximum of 30,000 mV. For values outside this range an AX1 input error warning appears.

### Enter installation menu

Press button 1 and 4 at the same time for 5 sec to open the User menu.

Press button 2 and 3 at the same time for 5 sec to open the installation menu.

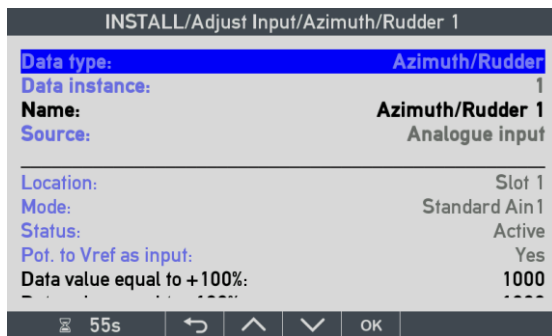
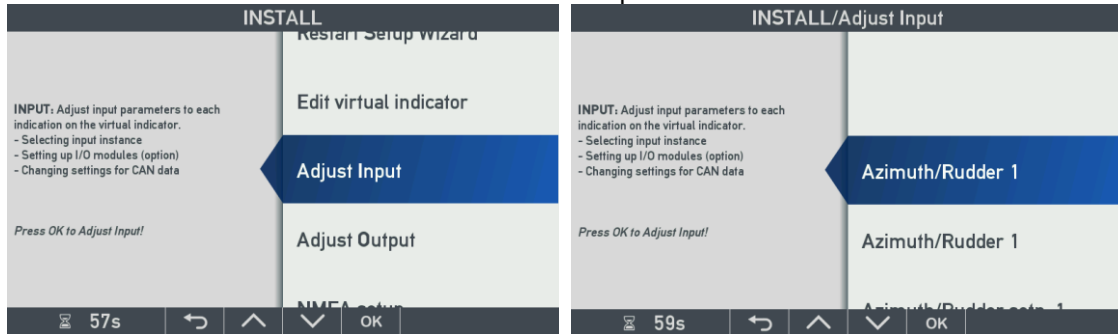

Make the above selections to enter the Azimuth/Rudder input adjust menu.

### Calibrating steps:

#### Step 1: Adjust rudder centre (zero set)

Position the rudder physically in the centre position (0 degree) and see if the rudder indication is also showing 0 degree on the XDi.

If the rudder indication is not correct change the Input point 2 value.

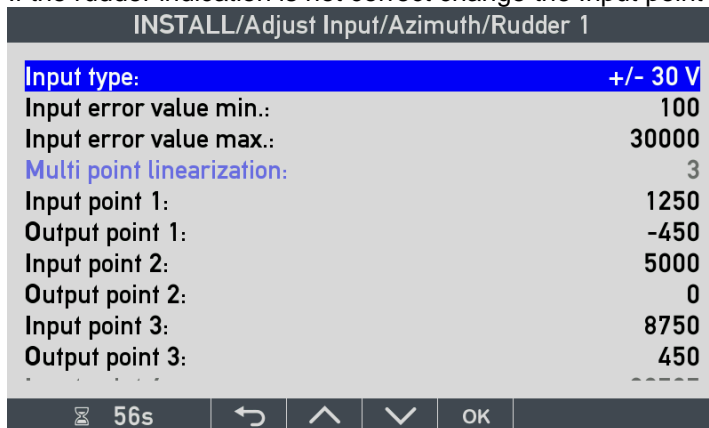

Highlight "Input point 2" and press OK.

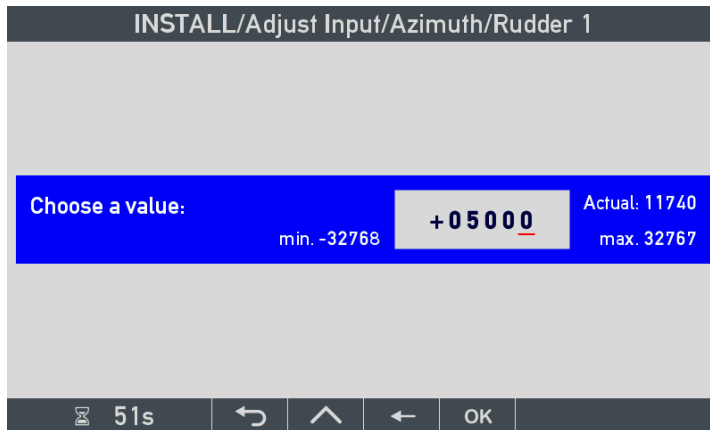

After a few seconds the actual input voltage value (in mV) is shown in the corner, reading 11740mV.

This means that when the sensor is in the centre position the voltage is not 12.0 V, but 11.740 V. Change the input value, BUT REMEMBER it is a relative value where measured  $V_{ref} = 10000$ .

The voltage between AGND and  $V_{ref}$  can be measured with a digital voltmeter to see the actual  $V_{ref}$  value. Alternatively, disconnect the sensor wire from +HV input 1 (term. 11) and connect terminal 11 shortly to terminal 3. After a short period, the actual  $V_{ref}$  value is shown as a new Actual value on the display.

Calculate the new relative value to enter into Input point 2 to scale the zero point.

For this example the new value is:  $11740\text{mV} \times 10000/24000\text{mV} = 4891.6666$ . Enter 4892 in the above menu and press OK.

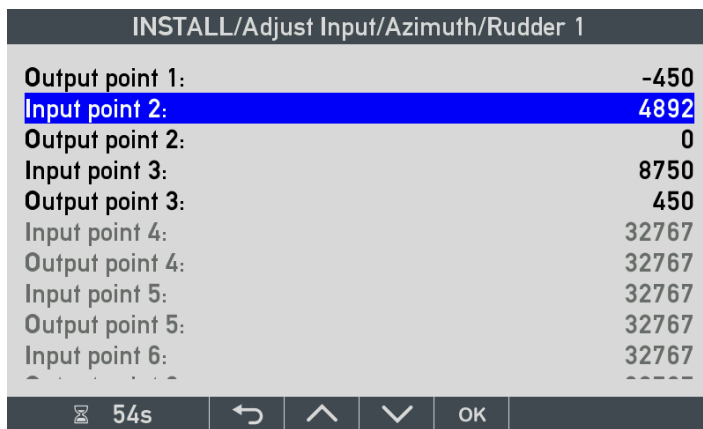

Now the zero point is adjusted. Leave the menu by pushing the  button several times.

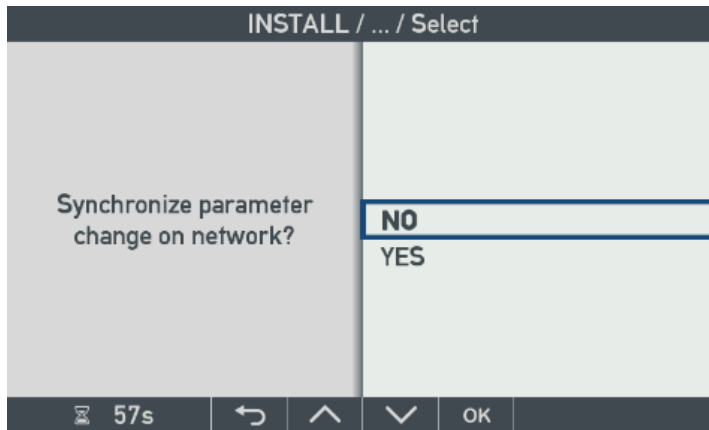

When you get this question select NO or just push  again.

You have left the installation menu and XDi is in normal operation and points to 0°.

### Step 2: Adjust portside angle (minimum set)

Turn the rudder to the maximum portside position, and read the physical angle.

Position the rudder at 45.0°, or select a value close to the maximum PS position. In this example 42.0° is used.

Adjust I/O pair 1:

Set the value of Output point 1 to the selected PS position. For 42.0° PS the value is -420 (- = PS).

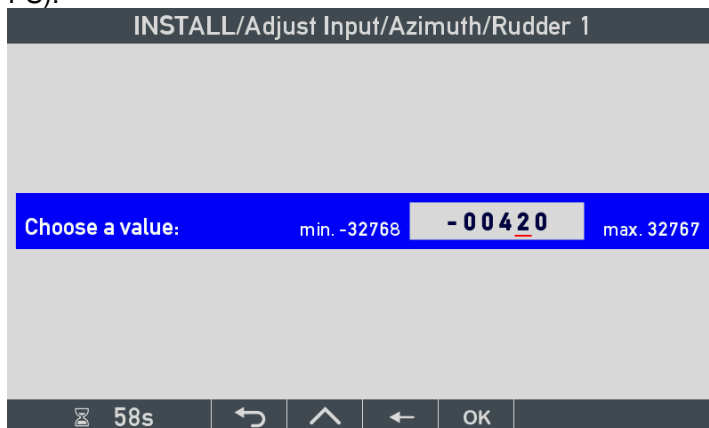

Highlight Input point 1 and press OK. Read the voltage value for the selected PS position.

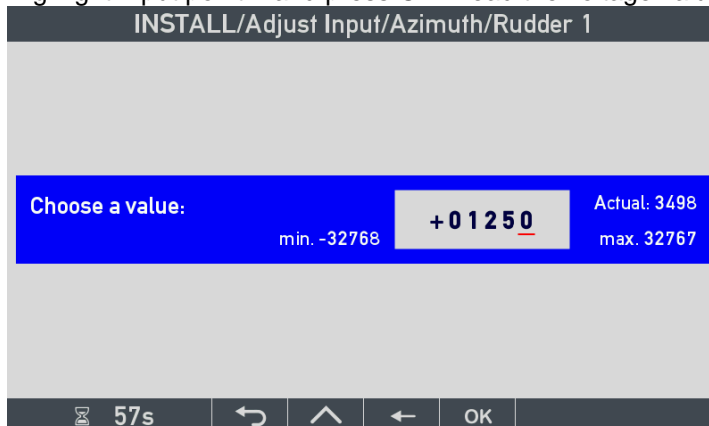

The actual voltage is 3498 mV at 42.0° for this example.  
 The new relative value is:  $3498 \text{ mV} \times 10000 / 24000 \text{ mV} = 1457$   
 Set the new relative value for Input point 1.

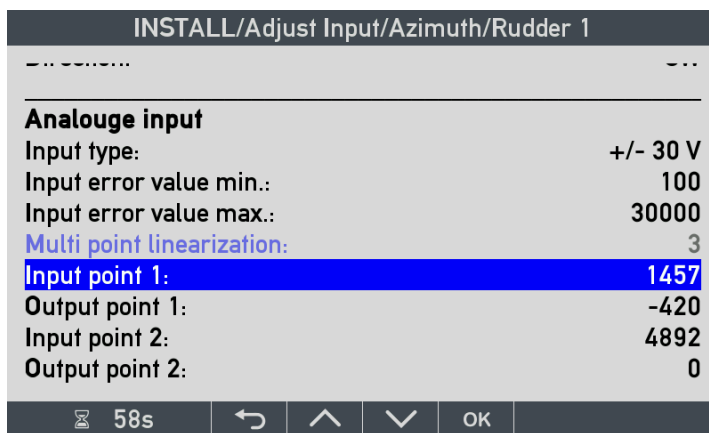
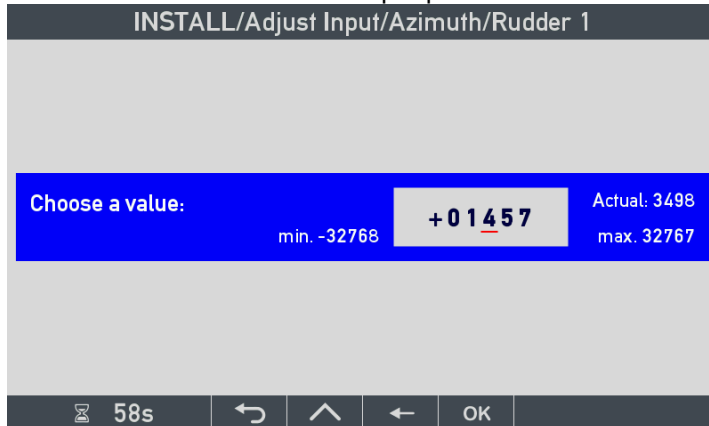

Press [Back] several times to leave the menu.

### Step 3: Adjust starboard angle (maximum set)

Repeat the procedure in Step 2 to set Input point 2 for the maximum starboard angle. (+ = SB)

## Appendix 1 - XDi setup wizard

### XDi setup during installation

When the XDi powered up for the first time, it automatically starts the setup wizard. This wizard will guide you through the setup process.



The library owner number, type, number and version are indicated in the second line. The library used in this example is the DEIF standard rudder indicator library no. 031. Press “OK” to continue.

### Select CAN node ID

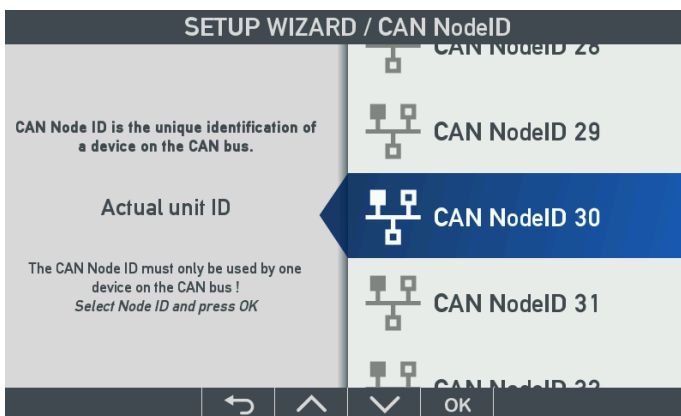

If the CAN bus/XDi-net is not used in your installation, press OK on the default CAN NodeID to continue.

In a system with multiple XDi indicators, you can use XDi-net (on CAN) to make a cost-effective, easy installation, plug-and-play system solution. In XDi-net, the CAN NodeIDs are not important as long as they are different for each unit.

Assigned the default CAN NodeID=30 for the first XDi unit. Assign NodeID=31 to the next XDi and so on.

If the same NodeID is selected for two XDi units on the same CAN bus, the warning “CAN NodeID conflict” is displayed. The CAN port does not function until each unit on the bus has a unique NodeID.

### Select Product Profile (PP)

The product profile (PP) in an XDi library contains all product and system related parameters. For example, the default CAN bus setup parameters, default dimmer and day/night shift setup parameters.

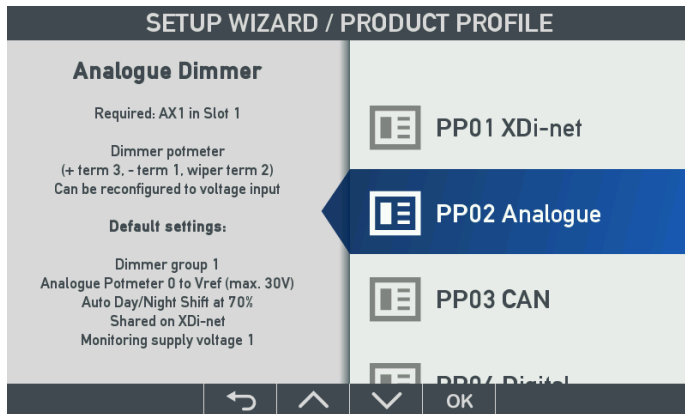

For each PP in the library, there is a description in the left side of the screen to help you make the right choice. Select the product profile that fits your system and press OK.

### Select virtual indicator (VI)

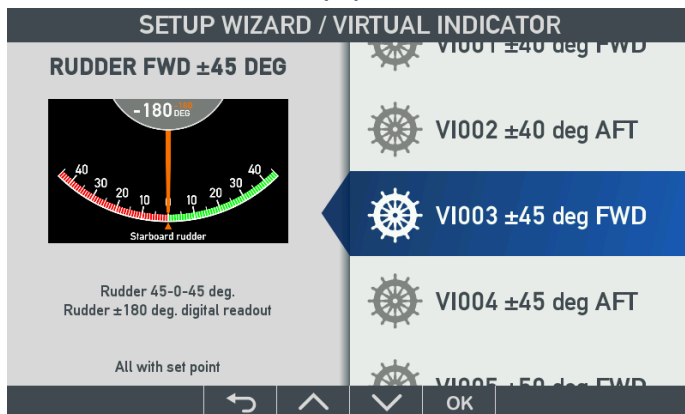

The next step is to select the rudder angle indicator (VI) that fits your system. The short description and thumbnail picture help you select the right one. Select the VI and press OK.

### Select virtual indicator setup (VS)

The VI setup (VS) defines the actual input setup for all pointers and digital readouts for the selected virtual indicator, and the outputs from the indicator to other systems. In the example, the selected virtual indicator VI003 has six VI-setup profiles to choose from.

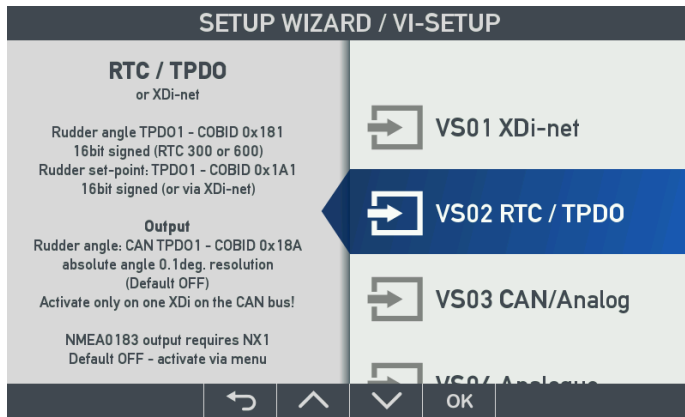

**VS02** profile is intended for use in a CAN bus system with a CAN angle transmitter connected as data source for rudder angle and another CAN bus parameter containing the commanded rudder value. The commanded rudder indicator can be disabled from menu.

This profile is also prepared for transmission of the actual rudder angle in a TPDO for other systems to use. For example, traditional XL indicators with sCAN input.

Select the VS profile and press OK.

### Finish

XDi is now set up. Press OK to finalise the setup and go to normal operational mode.

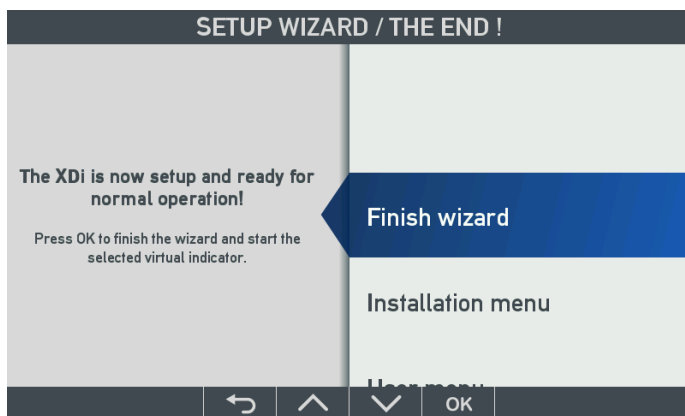

If the system has to be calibrated, the installation menu can be accessed directly. It is common to calibrate one XDi in a system and then share the calibration settings with the remaining XDi's. See the application description to determine how to calibrate the XDi system.

### Edit the indicator headline

The headline of the indicator can be changed from the XDi installation menu.

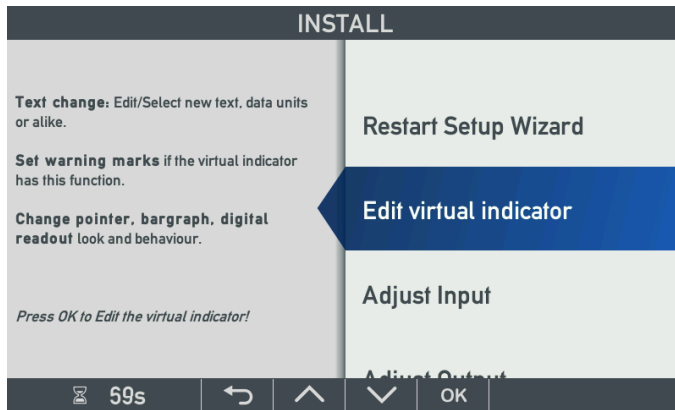

Select "Edit virtual indicator". Select "Text and units" and then select "Headlines".

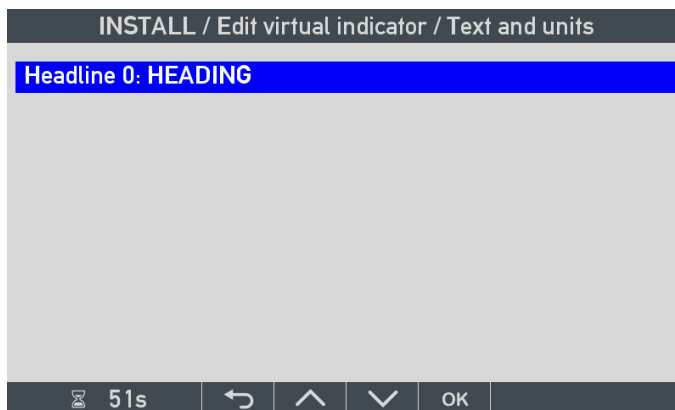

Press "OK" to select a new headline text from the list of predefined headlines:

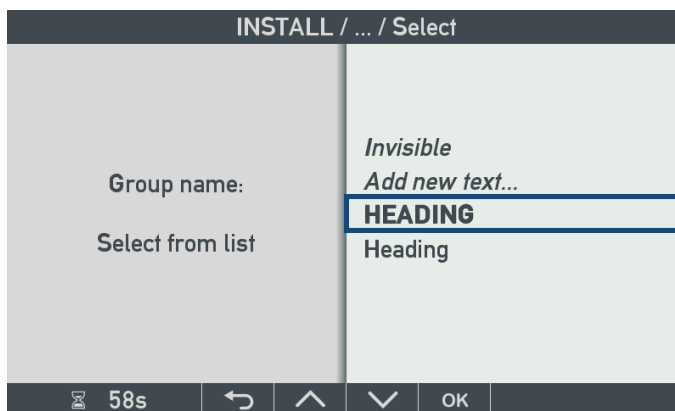

Alternatively, select "Add new text" to enter a new headline using the virtual keyboard. It is also possible to make the headline invisible.

INSTALL / Edit virtual indicator / Text and units									
[Empty text input field]									
Clear	<- Cursor				Cursor ->				<- BS
Q	W	E	R	T	Y	U	I	O	P
A	S	D	F	G	H	J	K	L	
@	Z	X	C	V	B	N	M	&	SAVE
^Sh	123+!#..?				SPACE				↩
⌚ 54s		←	^	→	OK				

## Appendix 2 – Angle transmitter load calculations

Load calculations are made to ensure the system has a reasonable safety margin to be able to function under all conditions.

### Calculating a 4-20 mA current loop system

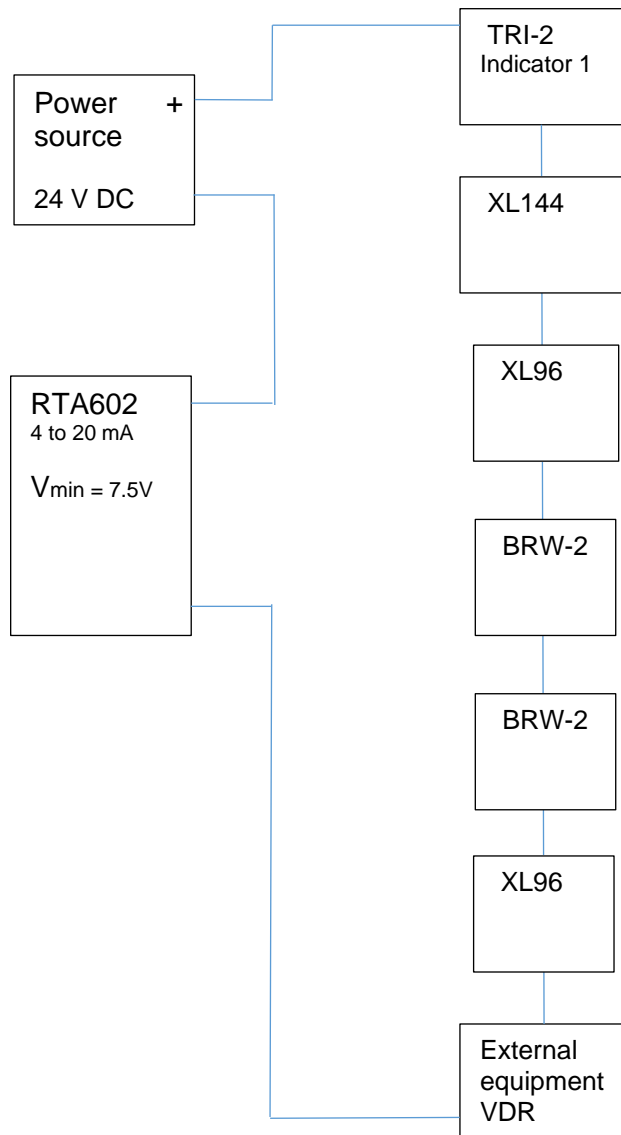

### Voltage drop calculation in a 4-20 mA system

For the example system above, the power source is a 24 V DC power supply with a battery backup. In the case of a main power failure, the system runs on the battery. The system must function normally even if the battery voltage drops by 20 %. This means the system must function with a 19.2 V power supply.

The RTA requires minimum 7.5 V across the output terminals to function and to be able to source a 20 mA output current. This means that a voltage drop across all connected serial indicators and other devices must not exceed 11.7 V at the maximum current of 20 mA. This must include the voltage drop in the signal wires.

The maximum load resistance is  $11.7 \text{ V}/20 \text{ mA} = 585 \Omega$ . Instead of adding individual voltage drops, you can add the load resistance of all serial connected devices and the resistance of all the signal wires together.

Connected unit	Voltage drop @ 20 mA	Load resistance
Indicator 1, TRI-2	3.0 V	150 $\Omega$
Indicator 2, XL144	1.0 V	50 $\Omega$
Indicator 3, XL96	1.0 V	50 $\Omega$
Indicator 4, BRW-2	1.0 V	50 $\Omega$
Indicator 5, BRW-2	1.0 V	50 $\Omega$
Indicator 6, XL96	1.0 V	50 $\Omega$
Equipment 1, VDR	1.0 V	50 $\Omega$
All cables in this example 35 $\Omega$	0,7 V	35 $\Omega$
Total consumption / resistance	9.7 V	485 $\Omega$
Max. available voltage / resistance	11.7 V	585 $\Omega$
<b>Safety margin</b>	<b>2.0 V</b>	<b>100 <math>\Omega</math></b>

If the system changes and new indicators are added or old indicators are replaced, it is recommended to recheck the voltage drop in the system.

### Load current calculation in a voltage driven system

In a voltage driven system all indicators and other equipment are parallel coupled to the output of the sensor system. The voltage output must be able to deliver a current which is higher than the current running through each connected indicator or other device.

In this system the RTA602 sensor is connected to a TDG-210 insulated amplifier that can convert the 4-20 mA input signal from the RTA sensor to a voltage signal.

The TDG output is able to output a maximum of 20 mA (source or sink). This output current limits the number of indicators that can be connected in parallel without overloading the output.

#### Example:

A calculation example for a +/-10 V indicator system is shown below.

The impact of the signal cable resistance is considered to be insignificant and is not included in the calculation.

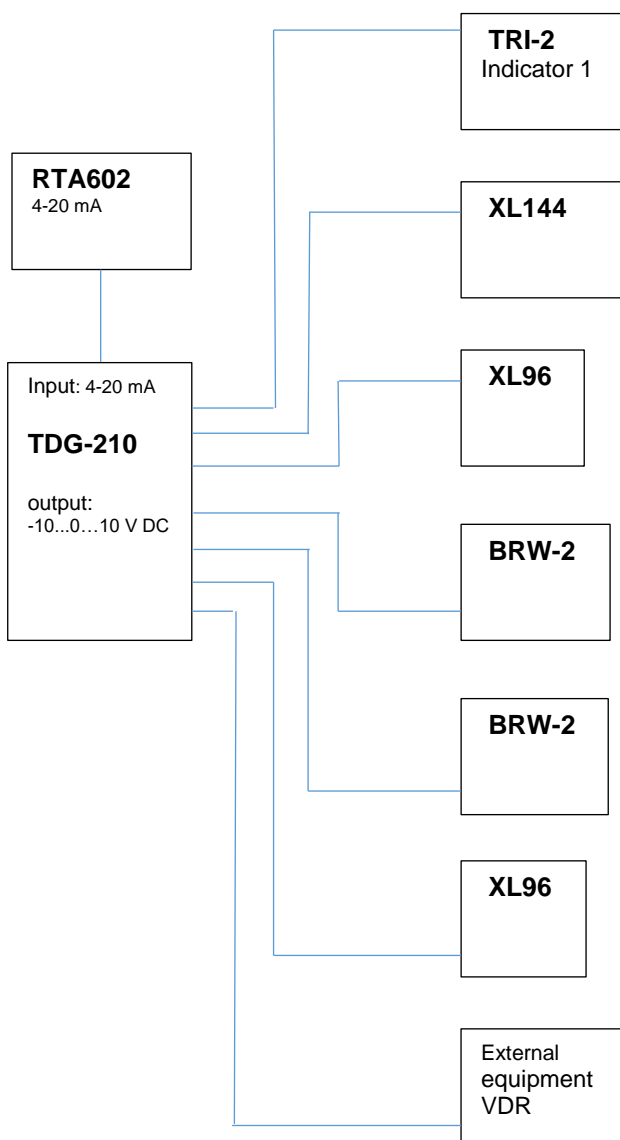

## Current calculation

For the above system, the total load of the TDG output is calculated by adding the current consumption at maximum voltage for each indicator (see the table below).

The maximum load occurs at the maximum positive and negative output voltage from the TDG.

Connected unit	Current @ -10 V	Current @ 10 V	Load resistance
Indicator 1, TRI-2	-0.7 mA	0.7 mA	14 k $\Omega$
Indicator 2, XL144	-1.0 mA	1.0 mA	10 k $\Omega$
Indicator 3, XL96	-1.0 mA	1.0 mA	10 k $\Omega$
Indicator 4, BRW-2	-1.0 mA	1.0 mA	10 k $\Omega$
Indicator 5, BRW-2	-1.0 mA	1.0 mA	10 k $\Omega$
Indicator 6, XL96	-1.0 mA	1.0 mA	10 k $\Omega$
Equipment 1, VDR	-1.0 mA	1.0 mA	10 k $\Omega$
Total consumption	-6.7 mA	6.7 mA	
Available current from TDG210	-20 mA	20 mA	
<b>Safety margin</b>	<b>-13.3 mA</b>	<b>13.3 mA</b>	

The load resistance is listed in the data sheet for the respective indicator or connected device.

In some cases, the load is specified in k $\Omega$ /V. For example, a 1 k $\Omega$ /V indicator with a 10 V input has an input resistance of 10 k $\Omega$ .

If the system changes and new indicators are added or old indicators are replaced, it is recommended to recheck the current consumption of the system.

## Appendix 3 - External dimming

XDi offers a number of different ways to control the dimmer level and day/night colour shift.

Dimmer data from external inputs are shared on XDi-net (CAN).

See the detailed description of the available Product Profiles (PP) with different default dimmer configurations in the library description document:

XDi144\_192\_D\_000001\_031\_rxxx\_v2xxx.pdf

or

XDi96\_D\_000001\_031\_rxxx\_v2xxx.pdf

The latest version can be downloaded from DEIF FTP server. See **XDi-Standard virtual indicator library 4189350067 UK** for more information about how to access the FTP.

### Dimming from external push-buttons

Connect a push-button to each contact input on the NX1 module to common and set them up to work similarly to front button 2 and 3. This is done in the installation menu: “NMEA setup...”\“NX button setup...”.

The external push-buttons dims the display in the same way as the two push-buttons on the front of the XDi. This function works with any Product Profile setup for dimming via front push-buttons.

The dimming buttons on the front of the XDi still work, and the dimmer setting for the active dimmer group is shared on XDi-net.

Only XDi 144 and XDi 192 have two extension slots allowing for installation of both AX1 and NX2 extension modules at the same time.

XDi 96 can have an AX1 module installed when it is receiving data via XDi-net. In this case, it can control other XDi 96 indicators in the same dimmer group via XDi-net.

### Dimming from external potentiometer (AX1)

In the standard library, product profile PP02 supports dimming from a connected potentiometer. This requires an AX1 analogue extension module mounted on slot 1 on the XDi.

The dimmer potentiometer must be connected to the AX1 module like this:

AX1 terminal	AX1 name	Potentiometer
1	AGND	Left (min)
2	HV3+/DIMM	Wiper
3	REF*	Right (max)

**\*Note** The REF terminal is a reference voltage output (+7.5 V DC). An external voltage >+7.5 V can be connected between REF (3) and AGND (1) to overwrite the ref. voltage. The dimmer level scales relative to the new, higher reference voltage.

The analogue dimmer value is shared via XDi-net to all XDi units in dimmer group 1 (default). The dimmer group can be changed to any group between 1 and 9.



**Note that the front button dimmer does not work when the AX1 module is controlling the dimmer level.**

## Dimming from analogue voltage input (AX1)

The product profile PP04, mentioned above, can be reconfigured from the user menu to act as a normal voltage input (range 0 to 30 V). The minimum and maximum dimmer input voltages must be set up to scale to 0 % and 100 % of the dimmer level. The voltage level specified in mV (1 V = 1 000 mV).

### Galvanic separation of analogue rudder angle and dimmer signals

If the measuring system (analogue rudder angle signal) has to be galvanically separated from the dimmer system, install a second AX1 module in Slot 2 of the unit. (only XDi 144 or XDi 192)

Select PP07 or PP08 to use the dimmer input on this module instead of the dimmer input on the AX1 module in Slot 1.

If all indicators are connected via CAN bus it is possible to run dimming control via the same CAN bus.

Dimming can be divided into dimmer groups and each group can use the front pushbuttons of the unit or an analogue dimmer input as described above.

XDi shares dimmer data via CAN if a product profile (PP) with a dimmer group 1 control is selected. You can change to another group from the XDi user menu (group 1 to 9 is available).

If a PP with local dimmer is selected then dimming is not shared via CAN.

Dimming via CAN from an external system is also possible, but will not be described in this section.

## XL dimming

The backlight of the XL series is controlled by LEDs. The backlight is developed to use the LEDs to illuminate the back of the scale of the XL indicator. This construction ensures that the backlight is evenly distributed across the scale and provides optimum illumination at night.

The backlight level is controlled by a voltage from 0 to 30 V. A higher voltage creates a brighter backlight.

To use a potentiometer to dim the backlight, connect the dimming input of the XL to the regulated voltage terminal of the potentiometer.

Dimming connection terminals for an analogue XL:

6	Illumination	Illumination+	Dimmer input. Dimmer range 7 to 30 V <sub>DC</sub> Consumption max 30 mA
7		GND	
8		NC	Not connected, can be used freely

Dimming connection terminals for a CAN XL:

9	Illumination analogue dimmer	NC	Dimmer input. Dimmer range 7 to 30 V <sub>DC</sub> Consumption max. 30 mA
10		Illumination GND	
11		Illumination +	

## BW 144 / 192, BRW-2 and TRI-2 dimming

BW, BRW and TRI indicator types have a build in potentiometer for dimming. If another type of dimmer is required, then refer to the respective data sheets for more information.

---

## Appendix 4 – Standard rudder indicators

---

### XDi rudder indicator libraries

The standard indicator rudder library consists of a selection of different rudder angle indicators for both forward and aft pointing bridge applications. The range of indicators expands over time.

During setup, select the indicator and the setup profiles that suits the installation the best.

You can find the latest content of DEIF standard libraries and a detailed description of indicators and setup profiles at [www.deif.com](http://www.deif.com). These are described in “XDi-Standard virtual indicator library 4189350067.pdf” located in the XDi document folder, under “Other technical documents”.

Link: <https://www.deif.com/products/xdi#documentation>.

In the document, you will find useful information and a link to the DEIF FTP server where the detailed library documentation and the DEIF standard library installation packages can be downloaded.

Open the folder “Standard Lib. documents” and “Owner\_1\_Lib031\_Rudder”.

The standard rudder library has library owner number 00001 and library number 031.

### XDi standard rudder indicator overview

Download the standard rudder library description (pdf) to get the latest updated overview of all available virtual rudder indicators for the different XDi sizes.

- XDi96\_D\_000001\_031\_r - - -\_v2 - - - .pdf
- XDi144\_192\_D\_000001\_031\_r - - -\_v2 - - - .pdf

### XL, BW, BRW-2 or TRI-2 standard rudder indicator scales

To get an overview of the most used standard rudder scales for XL, BW, BRW-2 and TRI-2 open this link: <https://www.deif.com/products/xl#documentation>

In “Other technical documents” open or download the document:  
“Illuminated indicators standard scale designs 4921290030 UK.pdf “

Contact DEIF if the rudder indicator you want is not shown in this overview. The indicator might be available already or a customised scale can be developed for your application.

## Appendix 5: XDi Disabling commanded rudder

The commanded rudder indicator can be disabled if it is not required.

Commanded data is presented with a small orange triangle pointer and an orange digital readout.

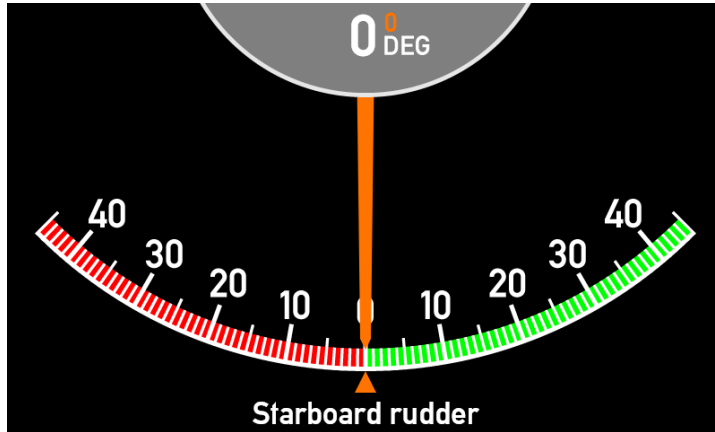

The commanded rudder presentation must be disabled on all XDi indicators where you do not want to use this feature. If it is not disabled on all units, then it is presented as an out of range fixed value, or as data loss if the unit uses a CAN bus data input.

To disable the commanded rudder indicator, enter the installation menu. Press button 1 and 4 for >5 s and when the user menu is open, press button 2 and 3 for >5 s. This opens the installation menu.



**The installation menu can be accessed directly in the last step of the setup wizard (see Appendix 1).**

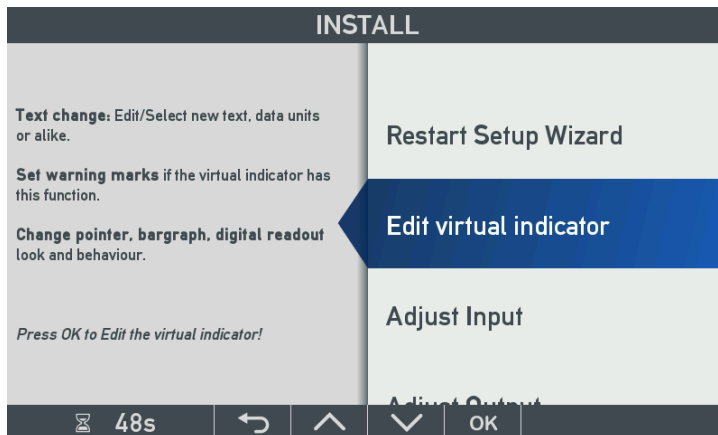

When the installation menu is open, highlight “Edit virtual indicator” and press OK.

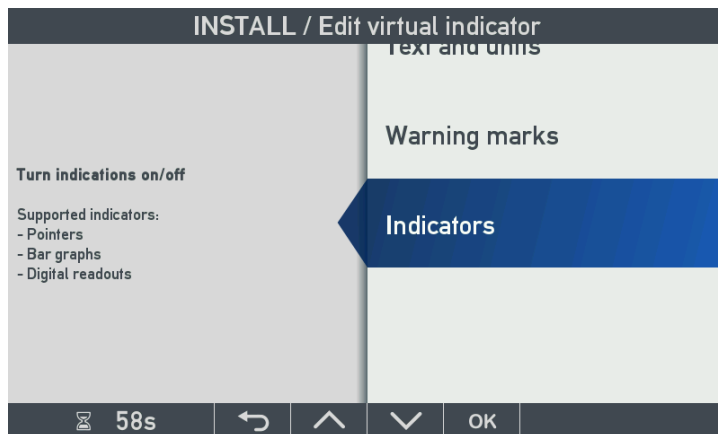

Highlight "Indicators" and press OK.

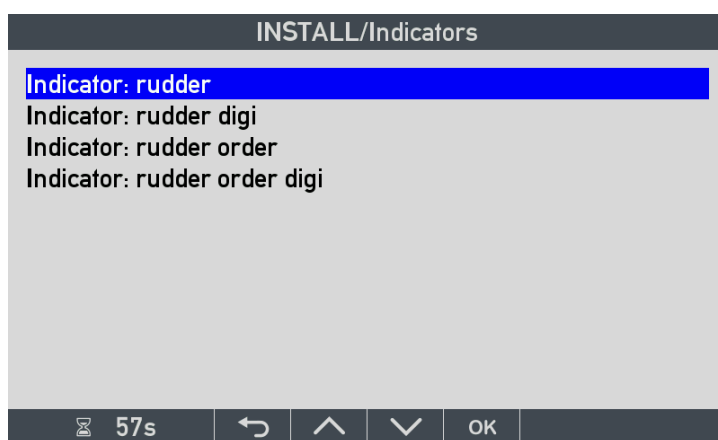

Highlight the first instance of "rudder order" and press OK.

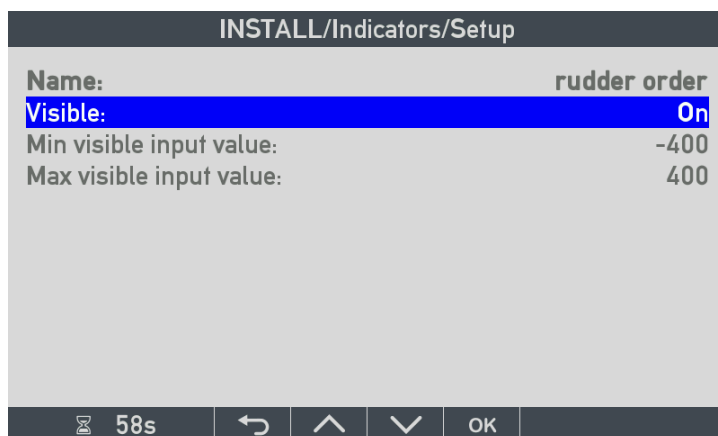

Select "Visible" and press OK.

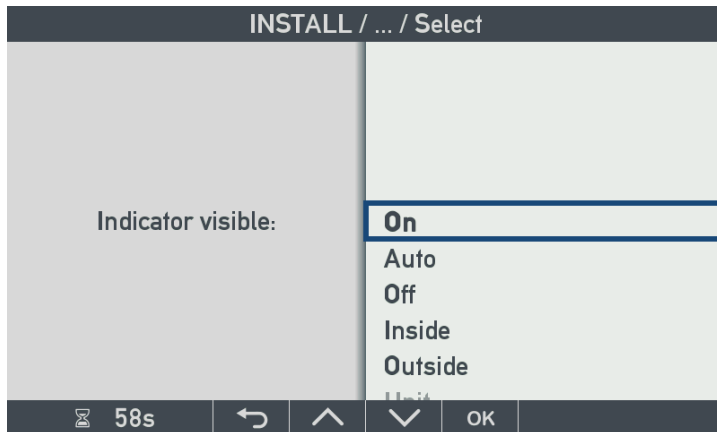

Select Off and press OK.

Step back a few times to reach this menu again:

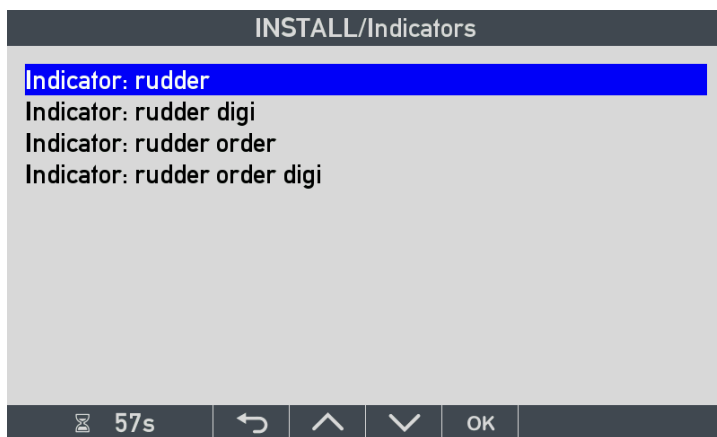

Follow the same procedure to disable "rudder order digi" (the orange digital readout).

Now the orange triangle pointer and the small orange digital readout are disabled.

The function has to be disabled on every unit where the commanded rudder angle is not required. The parameter is indicator specific and does not synchronise with other XDi's (even if yes to synchronization is selected when the menu is closed).

## Appendix 6 - Installing a CAN bus system

### XDi CAN bus ports

The XDi base unit is equipped with two CAN bus ports, with CANopen as the standard interface protocol. The unique DEIF XDi-net plug-and-play extension to the CANopen protocol is used in all DEIF standard libraries for easy data sharing. The XDi-net extension is also used in many custom specific libraries, to make system setup and integration easy.

This Appendix describes the basic CAN installation procedure. The example uses the DEIF standard rudder indicator system with multiple XDi indicators.

For more detailed information, consult the “XDi-net CANopen reference manual 4189350066 UK” which can be found on [www.deif.com](http://www.deif.com) under XDi documentation.

### CAN bus system wiring

The XDi unit can be connected to the CAN bus either by a short drop cable to the backbone or by daisy-chaining the backbone from unit to unit (see drawing).

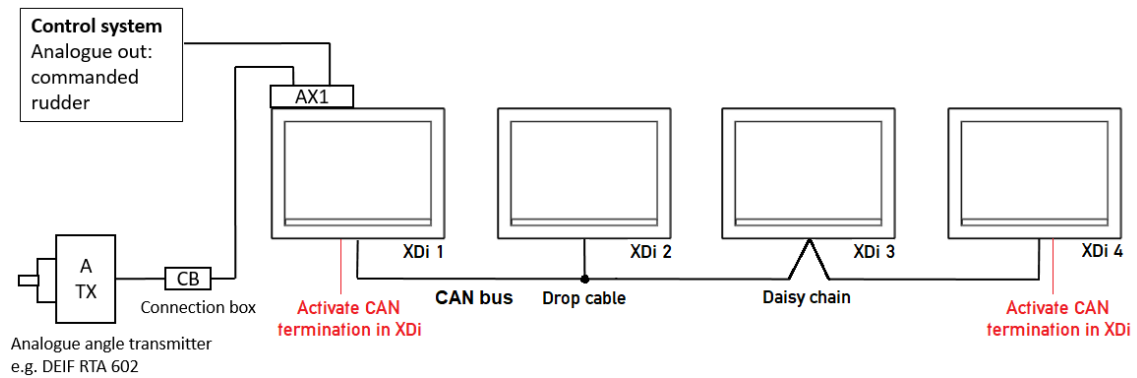

The standard terminal block, with a single row of 5 screw terminals, is well suited for a drop cable connection. Daisy chaining requires two wires to be mounted in each terminal location.

Recommendation: If daisy chaining is the preferred installation form, we recommend that you order the XDi unit with either the double screw terminal option or the double spring terminal option (see the **XDi data sheet** for ordering information).

### CAN backbone and termination

#### Termination

The CAN bus must be terminated at each end of the CAN bus cable line by a 120  $\Omega$  resistor. To make termination easy, the XDi has a built-in 120  $\Omega$  termination resistor. Set the switch to ON (see drawing) to activate the termination. Each CAN port has a separate built-in termination resistor and ON/OFF switch.

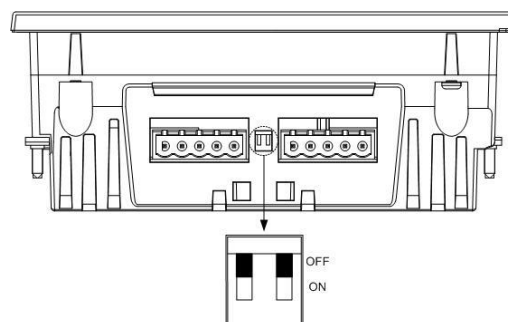



**Only two termination resistors can be connected in a CAN bus network. Adding more terminations will overload the CAN drivers, disturb communication and in the long run could damage the CAN driver circuit.**

### Termination example

These examples show two similar systems with two termination possibilities.

If the cable from the CAN angle transmitter exceeds the maximum allowed drop cable length (10 m @125 kbps), then a 120 Ω termination resistor must be installed in the connection box. The other termination can be made using the internal termination in XDi 4 (right side).

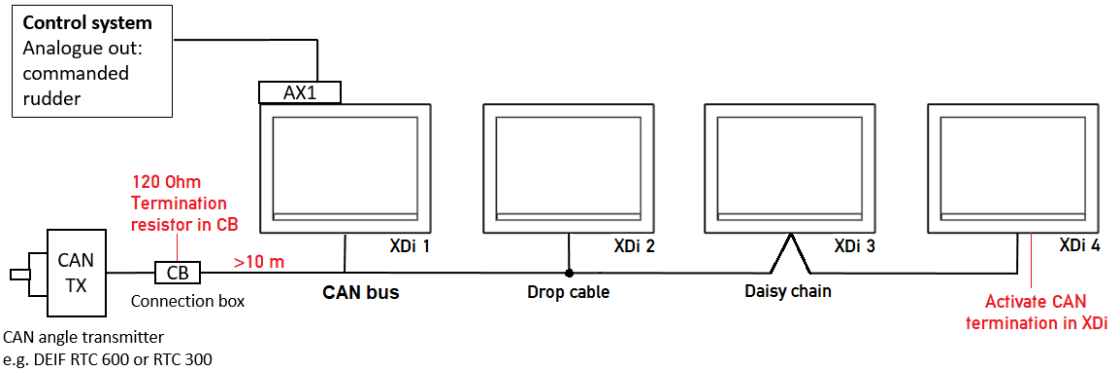

If the cable from the CAN angle transmitter is less than the maximum allowed drop cable length (10 m @125 kbps), then the CAN bus can be terminated using the internal terminations in XDi 1 (left side) and XDi 4 (right side).

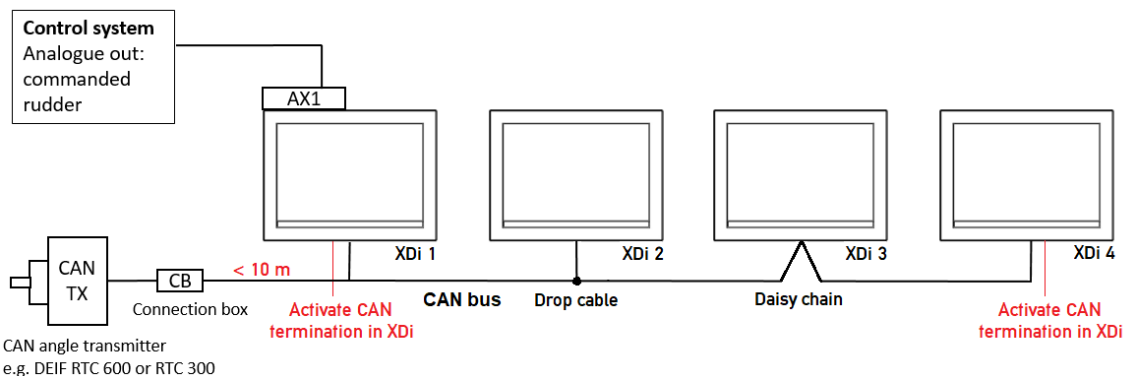

### Backbone and drop-cable

The CAN bus backbone is the CAN bus cable between the two endpoint terminations. Terminations should be inserted so that the most cable length is serially connected between the two terminations. This cable will then be defined as the backbone.

A cable section connected to the backbone in one end and to a product in the other end (without termination), is called a drop-cable. Drop-cables are not part of the backbone, but the length of all drop-cables must be included in the total allowed CAN bus cable length.

**Specifications of the data wire pair (twisted pair):**

Gage	Not less than AWG20/0.5 mm <sup>2</sup> (approx. 33 mΩ/meter). Where long supply cables are used, thicker wire is recommended and worst-case calculations of supply voltage drop in the cable should be performed
Characteristic impedance	120 Ω +/-10 % up to at least 500 kHz
Cable loss	The AC signal attenuation must be less than 24 dB/100 m up to 16 MHz
Propagation delay	Maximum 5 ns/meter

Guidelines for selecting CAN bus cable can also be found in ISO11898-2.



**If redundant CAN bus is used, the 2 CAN bus cables should be routed separately and at a safe distance from each other to reduce the risk of a single event damaging both CAN bus cables.**

**Shielding and grounding of the CAN bus cables****Cable shield**

Where CAN cables are connected, the cable shield must be interconnected. The cable shield must not be connected to the CAN GND terminal on the XDi. CAN GND is a “common” terminal that must only be used if there is an extra “common mode wire” included in the CAN cable (that is the twisted pair for data + one common wire). This extra wire reduces common mode voltage between CAN devices on the bus, but it is only rarely used in marine applications.

**Grounding of the CAN bus cable**

It is recommended to connect the shield, of the total CAN bus network, to the ship’s ground in one single location.

It is important that the ground connection is free from noise and transients from other devices using the same ground connection. If a good and noiseless ground connection is not available, it is normally better to leave the CAN bus cable shield ungrounded.



**Using multiple ground connections on the CAN bus cable can create electrical noise loops that disturb the CAN bus communication.**

**Special analogue to CAN configuration**

The analogue signals for commanded and actual rudder angle do not need to be connected to the same XDi.

In this example the first XDi is located in the engine control room where the analogue rudder transmitter is connected to the AX1 module. This XDi distributes the actual rudder angle via XDi-net to the other two indicators in the system.

The rudder control system is located on the bridge and has a 4-20 mA output that is connected to the XDi with AX1 module located in the centre console on the bridge. This unit is distributing the commanded rudder angle to the other two XDi indicators via XDi-net.

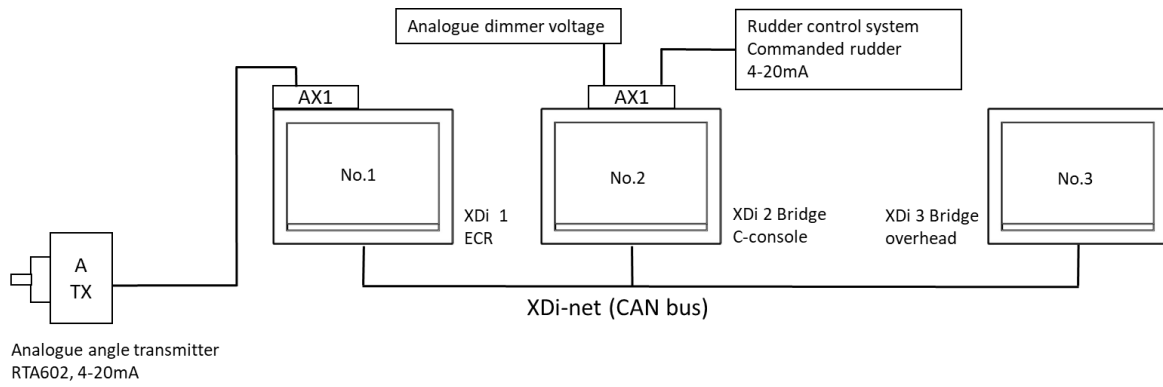

All XDi indicators are using the standard indicator library for XDi 144/192D, VI003: +/-45°.

It is important to select the correct VS profile for each indicator in this system.

XDi	No.1	No.2	No.3
Type	XDi 144D	XDi 192D	XDi 192D
VS profile	VS07	VS08	VS01
Actual angle input	4-20 mA	XDi-net	XDi-net
Commanded angle in	XDi-net	4-20 mA	XDi-net