

The Piezoelectric Effect

Piezoelectric Effect Basics

A piezoelectric substance is one that produces an electric charge when a mechanical stress is applied (the substance is squeezed or stretched). Conversely, a mechanical deformation (the substance shrinks or expands) is produced when an electric field is applied. This effect is formed in crystals that have no center of symmetry. To explain this, we have to look at the individual molecules that make up the crystal. Each molecule has a polarization, one end is more negatively charged and the other end is positively charged, and is called a dipole. This is a result of the atoms that make up the molecule and the way the molecules are shaped. The polar axis is an imaginary line that runs through the center of both charges on the molecule. In a monocrystal the polar axes of all of the dipoles lie in one direction. The crystal is said to be symmetrical because if you were to cut the crystal at any point, the resultant polar axes of the two pieces would lie in the same direction as the original. In a polycrystal, there are different regions within the material that have a different polar axis. It is asymmetrical because there is no point at which the crystal could be cut that would leave the two remaining pieces with the same resultant polar axis. Figure 1 illustrates this concept.

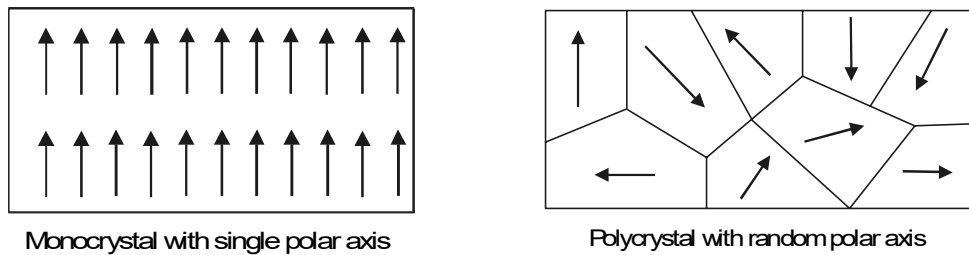

Figure 1: Mono vs. Poly Crystals

In order to produce the piezoelectric effect, the polycrystal is heated under the application of a strong electric field. The heat allows the molecules to move more freely and the electric field forces all of the dipoles in the crystal to line up and face in nearly the same direction (Figure 2).

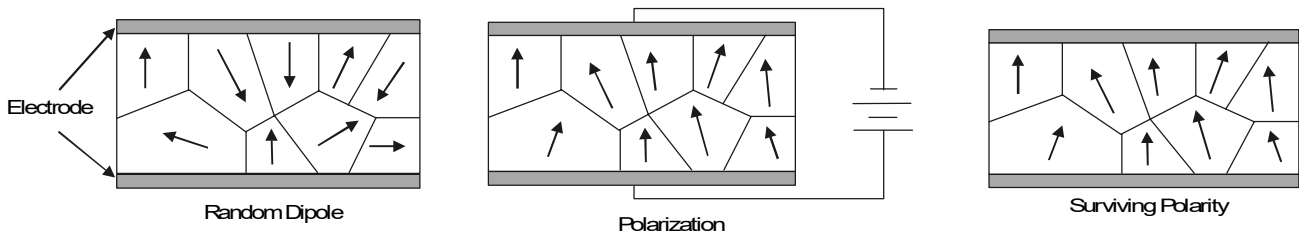

Figure 2: Polarization of Ceramic Material to Generate Piezoelectric Effect

The piezoelectric effect can now be observed in the crystal. Figure 3 illustrates the piezoelectric effect. Figure 3a shows the piezoelectric material without a stress or charge. If the material is compressed, then a voltage of the same polarity as the poling voltage will appear between the electrodes (b). If stretched, a voltage of opposite polarity will appear (c). Conversely, if a voltage is applied the material will deform. A voltage with the opposite polarity as the poling voltage will cause the material to expand, (d), and a voltage with the same polarity will cause the material to com-

press (e). If an AC signal is applied then the material will vibrate at the same frequency as the signal (f).

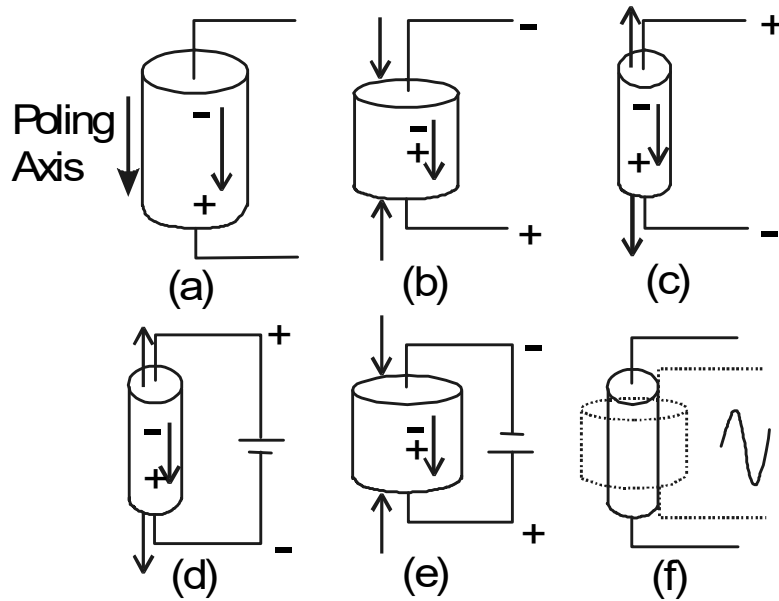

Figure 3: Example of Piezoelectric Effect

Using the Piezoelectric Effect

The piezoelectric crystal bends in different ways at different frequencies. This bending is called the vibration mode. The crystal can be made into various shapes to achieve different vibration modes. To realize small, cost effective, and high performance products, several modes have been developed to operate over several frequency ranges. These modes allow us to make products working in the low kHz range up to the MHz range. Figure 4 shows the vibration modes and the frequencies over which they can work.

An important group of piezoelectric materials are ceramics. Murata utilizes these various vibration modes and ceramics to make many useful products, such as ceramic resonators, ceramic bandpass filters, ceramic discriminators, ceramic traps, SAW filters, and buzzers.





Vibration Mode		Frequency (Hz)								Application
		1K	10K	100K	1M	10M	100M	1G		
Flexure Vibration		█	█	█						Piezo Buzzer
Lengthwise Vibration					█	█				KHz Filter
Area Vibration					█	█				KHz Resonator
Radius Vibration					█	█				
Thickness Shear Vibration						█	█			MHz Filter
Thickness Trapped Vibration						█	█			MHz Resonator
Surface Acoustic Wave							█	█	█	SAW Filter SAW Resonator
BGS Wave							█	█		SH Trap SH Resonator SH Filter

Figure 4: Various Vibration Modes Possible with Piezoelectric Ceramics

Piezoelectric Resonators

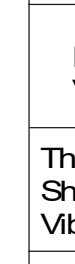
Introduction

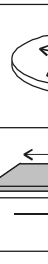
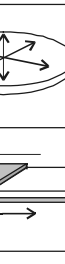
Ceramic resonators are piezoelectric ceramic devices that are designed to oscillate at certain frequencies. They are highly stable, small, inexpensive, and do not require tuning or adjusting. Other common resonant devices are quartz crystal and discrete LC/ RC resonators. Although ceramic resonators do not have as good a total oscillation frequency tolerance as quartz crystal resonators, they are much more frequency tolerant than LC or RC circuits, and smaller and cheaper than quartz.

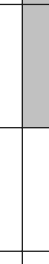
Resonators are typically used with the clock circuitry found built-in to most microcontrollers to provide timing for the microcontrollers. The resonators by themselves cannot be clocks, because they are passive components (components that consume electrical energy). In order for a resonator to oscillate, an active component (a component that produces electrical energy) is needed. This active component is typically included in microcontrollers and is usually referred to as the clock circuit. There are prepackaged stand-alone oscillator circuits that have both the active and passive parts in one package. To explain, a discussion of oscillation principles is needed.

Principles of Oscillation

There are two main types of oscillating circuit, Colpitts and Hartley. These circuits are shown in Figure 5.

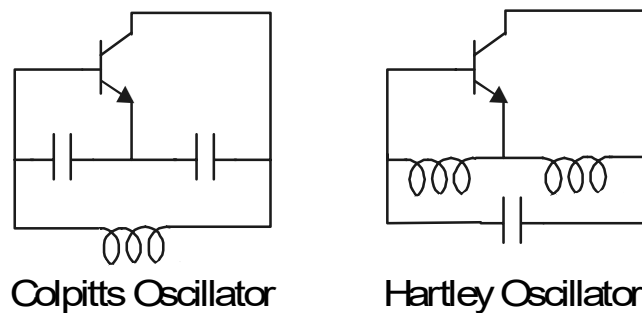

Figure 5: Colpitts and Hartley Oscillator

The Colpitts circuit is normally used (over the Hartley circuit) because it is cheaper and easier to have two capacitors and one inductor rather than two inductors and one capacitor. These circuits oscillate because the output is fed back to the input of the amplifier. Oscillation occurs when the following conditions are met (Barkhausen Criterion for oscillation): loop gain $(\alpha \times \beta) \geq 1$ and phase $\varphi = \varphi_1 + \varphi_2 = 360^\circ \times n$ ($n = 1, 2, 3, \dots$). Figure 6 illustrates the idea of feedback oscillation.

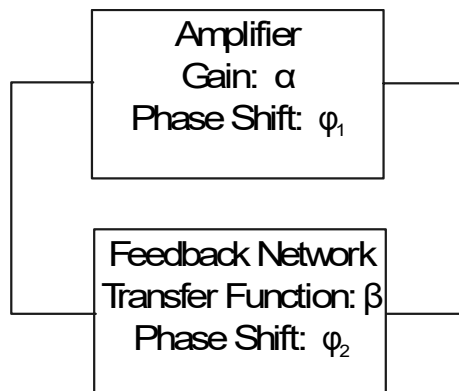

Figure 6: Block Diagram of Oscillator

Gain/Phase Conditions vs. Barkhausen Criterion

It is possible to look at the true gain and phase response of an oscillation circuit. This is different from the loop gain we refer to when talking about Barkhausen criterion. True gain / phase measurement is done by breaking open the oscillation circuit and measuring the gain and phase response of the circuit using a gain/phase analyzer or a signal generator with a vector voltmeter. Such measurement can provide a very accurate picture as to whether or not the oscillation circuit will actually oscillate.

As an example of the measured gain/phase results, the circuit gain/phase response shown in Figure 7a can oscillate because it has a gain greater than 0dB at the zero crossing point of the phase. The circuit gain/phase response in Figure 7b will not oscillate because the gain is less than 0dB when the phase crosses zero. A gain greater than 0dB is needed when the phase crosses the 0 degree axis in order for oscillation to occur.

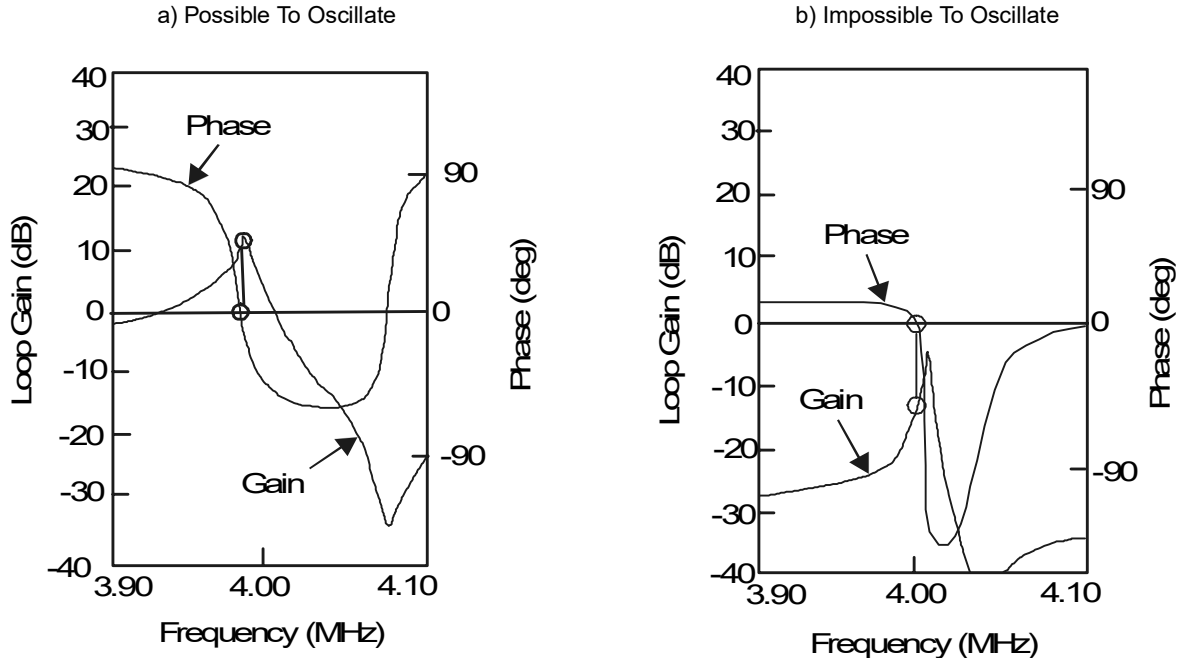

Figure 7: Gain - Phase Plots for Possible and Impossible Oscillation

The circuit in Figure 8 is the circuit used for these gain phase measurements. The oscillation circuit is broken open and a signal generator applies a range of frequencies to the inverter (amplifier). At the output of the circuit (after the resonator / feedback network), a vector voltmeter is used to measure gain and phase response at each frequency.

As mentioned in the example above, the gain must be greater than 0dB where the phase crosses the zero degree axis. Sometimes the loop gain of the Barkhausen criterion is confused for this gain condition (greater than 0dB). In the previous section, it was mentioned that for Barkhausen criterion to be met, loop gain ($\alpha \times \beta$) must be greater than or equal to one ($(\alpha \times \beta) \geq 1$). This may sound like a contradiction when we mention that the gain/phase measurement must be at least 0dB for oscillation to occur. Why is one loop gain at 1 and the other at 0?

The reason for this confusion is that Barkhausen $\alpha \times \beta$ is a unitless quantity and not a decibel measurement (like the loop gain in a gain/phase measurement). Both conditions really say the same thing, but in two different ways. The expression for calculating loop gain (in decibels) is $10\log(V_2/V_1)$, where V_2 is output voltage and V_1 is input voltage. α and β are actually gain multiplying factors and are unitless. Since the oscillation circuit is broken open, as shown in Figure 8, the voltage from the frequency generator is passed through the amplifier (multiplied by α), passed through the feedback network (multiplied by β), and passed through the vector voltmeter. From this, you can use the following expression to show what V_2 is in terms of V_1 , α , and β : $V_2 = V_1 \times \alpha \times \beta$. This can be re-written into this form: $V_2/V_1 = \alpha \times \beta$, and substituted in to the decibel loop gain equation: $\text{Gain (dB)} = 10\log(\alpha \times \beta)$.

This equation is a key point. From Barkhausen criterion, $\alpha \times \beta$ must be 1 for oscillation to occur. If 1 is substituted into the new equation: $\text{dB} = 10\log(1)$, the dB calculation will equal 0dB.

For oscillation to occur Barkhausen criterion must be met ($\alpha \times \beta \geq 1$), which is the same as saying the loop gain measurement must be ≥ 0 dB (at the zero crossing of the phase).

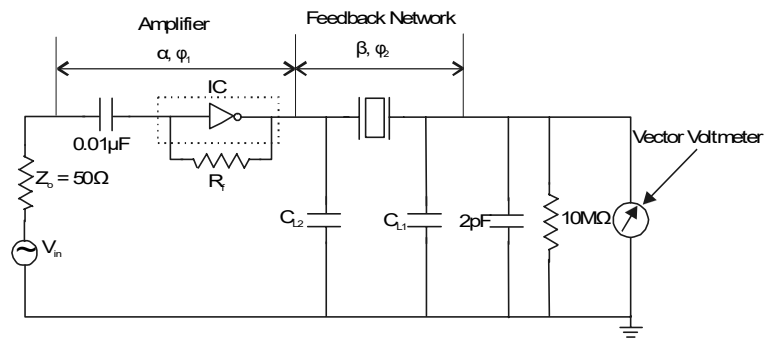

Figure 8: Gain - Phase Test Circuit

How Does It Work

Why Resonators

The most common use of a resonator, ceramic or quartz crystal, is to take advantage of the fact that the resonator becomes inductive between the resonant and anti-resonant frequencies (see Figure 9), which allows replacement of the inductor in the Colpitts circuit.

Ceramic Resonator Basics

A ceramic resonator utilizes the mechanical vibration of the piezoelectric material. Figure 9 shows the impedance and phase characteristics of a ceramic resonator. This plot of impedance and phase is made using a network analyzer, sweeping the resonator around its oscillation frequency. The graphs show that the resonator becomes inductive between the resonant frequency, f_r , and the anti-resonant frequency, f_a . This means that the resonator can resonate (or the oscillator using the resonator can oscillate) between these two frequencies.

Figure 9 also shows that the minimum impedance for the resonator occurs at f_r (called the resonant impedance) and the maximum impedance occurs at f_a (called the anti-resonant impedance). At most other frequencies, the resonator is capacitive, but there are other frequencies at which the part is inductive (referred to as overtones). Since the resonator appears to be an inductor (with some small series resistance) at the resonant frequency, we can use this part to replace the inductor shown in the Colpitts oscillator in Figure 5. You will want to replace the inductor with a resonator that resonates at the desired frequency.

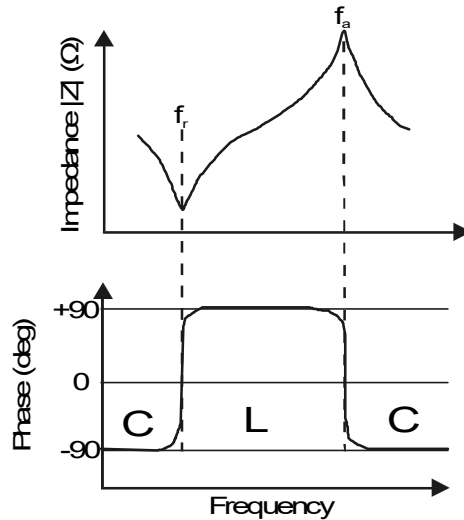

Figure 9: Resonator Impedance and Phase Plot

The Resonator Circuit Model

Looking at the resonator's characteristics we see an equivalent circuit for the resonator consisting of a capacitor (C_1), inductor (L_1), and resistor (R_1) in series and a capacitor (C_o) in parallel (Figure 10).

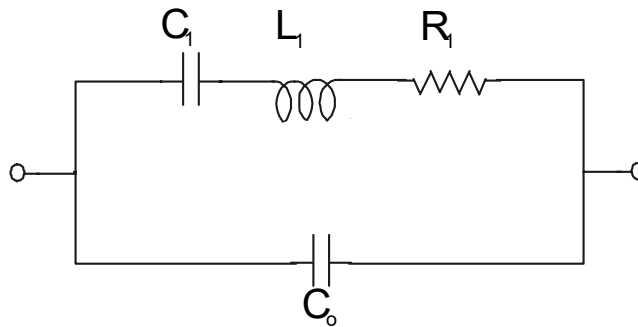

Figure 10: Equivalent Circuit Model for Two Terminal Ceramic Resonator

If the equivalent circuit values are known, then we can use this circuit to calculate the values of f_r , f_a , ΔF and Q_m using the following equations:

$$f_r = \frac{1}{2\pi\sqrt{L_1C_1}} \quad f_a = \frac{1}{2\pi\sqrt{\frac{L_1C_1C_o}{C_o + C_1}}} \quad \Delta F = f_a - f_r \quad Q_m = \frac{1}{2\pi f_r C_1 R_1}$$

Equation 1: Equations for Calculating Resonator Parameter based on Equivalent Circuit Model

ΔF is the difference between the resonant and anti-resonant frequencies.

Q_m is the mechanical Q of the resonator.

Appendix 1 gives the equivalent circuit values of some common resonators.

Between the resonant and anti-resonant frequencies (where is possible for the resonator to resonate in an oscillation circuit) the equivalent circuit simplifies to an inductor and resistor in a series connection. This is why the resonator can be used to replace the inductor in the Colpitts circuit. The resonator can be designed to work over different frequency ranges by changing the shape of the ceramic element and the vibration mode.

Overtones of the Resonator

The ceramic resonator will oscillate at a fundamental frequency (between f_r and f_a) but can also be made to oscillate at odd overtones of the fundamental frequency. This odd overtone oscillation can be done intentionally (as in the case of third overtone resonators to be discussed later) or as a result of a poorly designed oscillation circuit. These overtones occur naturally in resonators and have impedance and phase responses similar to the fundamental except that they are smaller and occur at odd multiples of the fundamental frequency (Figure 11). Even overtone oscillation is not possible with ceramic resonators.

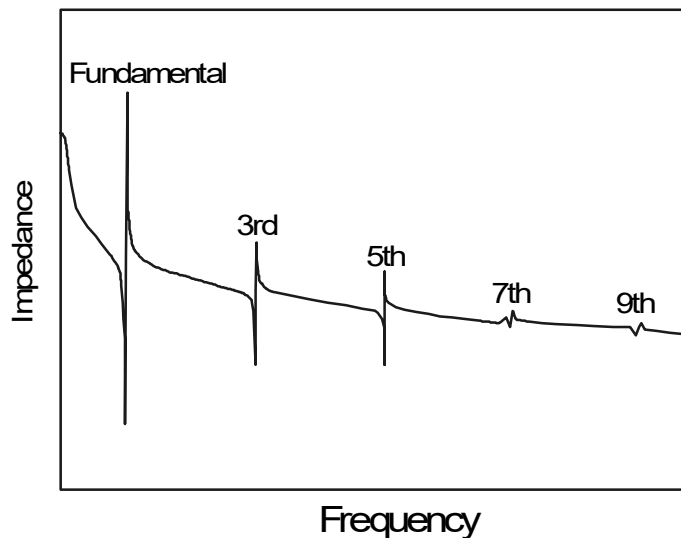

Figure 11: Ceramic Resonator Impedance Response Plot Showing Odd Overtones

In the figure, you can see the fundamental frequency and the 3rd, 5th, 7th, etc. overtones. When power is applied to the oscillation circuit, the oscillation begins as high frequency noise and drops in frequency (moves from right to left in Figure 11) until it reaches a point that meets the stable oscillation criteria (Barkhausen Criterion) discussed earlier. In a well designed circuit, this point will be at the fundamental response or an intentionally desired third overtone response. When designing lower frequency resonators (below ~13MHz), we design the resonator to have the intended oscillation frequency occur at the fundamental. For higher frequency parts (above ~13MHz), we actually use the 3rd overtone response. To achieve operating frequencies above 12~13MHz, it is most efficient to use the 3rd overtone, instead of trying to design a fundamental mode resonator for these frequencies. Since we are dealing with ceramic material, a combination of various raw materials which are mixed together and then fired, we do not have to live with the weakness of quartz crystal based resonators, when used in 3rd overtone operation. Quartz crystals use a grown crystal material, which does not allow for material changes. To allow a quartz resonator to operate at the 3rd overtone, the fundamental response of the quartz resonator must be suppressed, typically by an external tank circuit. Use of an external tank circuit adds to the cost and complexity of oscillator design.

For ceramic resonators, using the aeolotropic ceramic material (different from standard ceramic material), the fundamental frequencies are naturally suppressed, without the need of an external tank circuit, and the 3rd harmonics can be easily used for oscillation (Figure 12). This use of aeolotropic material allows for the efficient and cost effective manufacture of higher frequency resonators.

Since the 3rd overtone is three times the fundamental frequency, using 3rd overtone can extend the frequency range covered by ceramic resonators considerably (up to 60MHz). Ceramic resonators, unlike quartz crystal resonators, do not require an external tank circuit for 3rd overtone operation, due to the aeolotropic ceramic material.

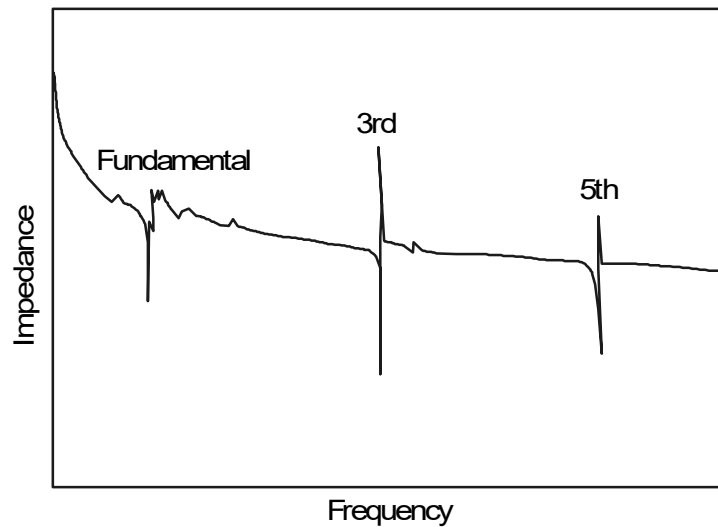

Figure 12: Impedance Response of Third Overtone Based Ceramic Resonator

As shown in Figure 12, the fundamental response of the ceramic resonator is suppressed to the point that the 3rd overtone appears to be the main (“fundamental”) response of the oscillation circuit. Please note that greater care must be taken in designing the oscillation circuit, since it is easier to have suppressed fundamental or 5th overtone spurious oscillations (compared to fundamental resonator’s spurious oscillations at 3rd or 5th overtone).

Vibration Modes

Ceramic resonators can employ one of several possible vibration modes, depending on the desired oscillation frequency. The vibration mode used is dictated by the target frequency of the resonator. The vibration mode selected dictates the basic shape of the resonator. In the following, each vibration mode used commonly for ceramic resonators and the range of oscillation frequencies possible are explained in more detail.

- Area Vibration (375kHz to 1250kHz)

The kHz range resonators utilize **area vibration** in their operation (Figure 13). In this mode, the center of the substrate is anchored while the corners of the material expand outward. This vibration mode suffers from spurious oscillation due to thickness vibration, but core circuit design can easily suppress such spurious oscillation. The resonant frequency is determined by the length of the square substrate. This mode operates from about 375kHz to 1250kHz.

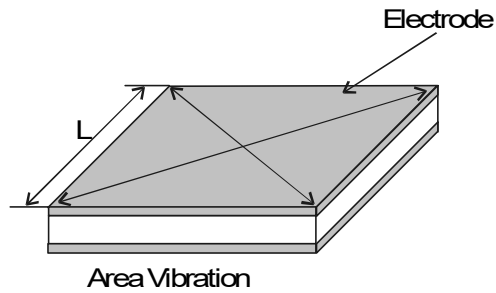

Figure 13: Ceramic Element for Area Vibration

- Thickness Shear Vibration (1.8MHz to 6.3MHz)

The MHz range resonators use two vibration modes. The first MHz range vibration mode is **thickness shear vibration** (Figure 14). In this mode, the substrate expands in thickness as well as diagonally. The resonant frequency is determined by the thickness of the substrate. This mode works from 1.8MHz to 6.3MHz.

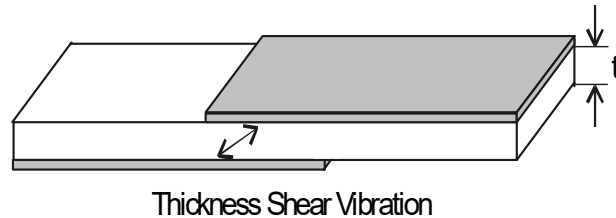

Figure 14: Ceramic Element for Thickness Shear Vibration

- Thickness Longitudinal Vibration (6.3MHz to 13.0MHz)

The second MHz range vibration mode is **thickness longitudinal vibration** (Figure 15). In this mode, the substrate thickness expands and contracts. The resonant frequency is determined by the thickness of the substrate. This mode operates from 6.3MHz to 13.0MHz. Using 3rd overtone this range can be extended to cover 12MHz to 60MHz.

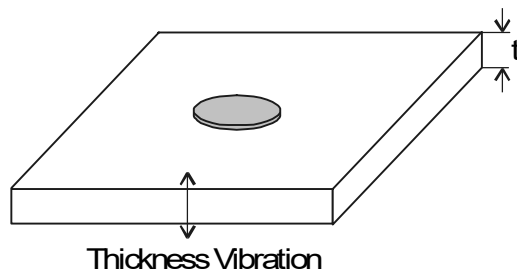

Figure 15: Ceramic Element for Thickness Longitudinal Vibration

- Thickness Longitudinal Vibration, Third Overtone (13.0MHz to 60.0MHz)

By taking the thickness longitudinal vibration mode mentioned above and changing the ceramic material to an aeolotropic ceramic material, the fundamental response of the thickness longitudinal vibration mode is suppressed allowing use of the third overtone. Figure 15 still represents this vibration mode, except that aeolotropic ceramic material is used. By using this third overtone of the thickness longitudinal vibration mode, it is possible to make ceramic resonators up to 60MHz.

Resonator Configurations

Resonators can come in two different configurations. A resonator can be supplied in a two terminal package (leaded or SMD) or in a three terminal package (leaded or SMD). For the two terminal package (Murata part numbers with the CSA prefix), the ceramic resonator element is connected between the two terminals. For the three terminal package (Murata part numbers with the CST prefix), there is an additional terminal between the two terminals of the two terminal type resonator. This third or middle terminal is a ground terminal for the built-in load capacitors. Recall from Figure 5 where the Colpitts oscillator is shown, there is a single inductor and two capacitors. The inductor would be replaced by the ceramic resonator, but the external capacitors (called load capacitors) must still be added. The three terminal resonator offers the convenience of having these two load capacitors built-in to the resonator, where this middle terminal is the ground for the load caps. The load capacitors that Murata builds into the resonator also provide some benefit in off-setting shifts in oscillation frequency due to temperature effects. Figure 16 shows the common lower frequency resonator packages for two and three terminal resonators.

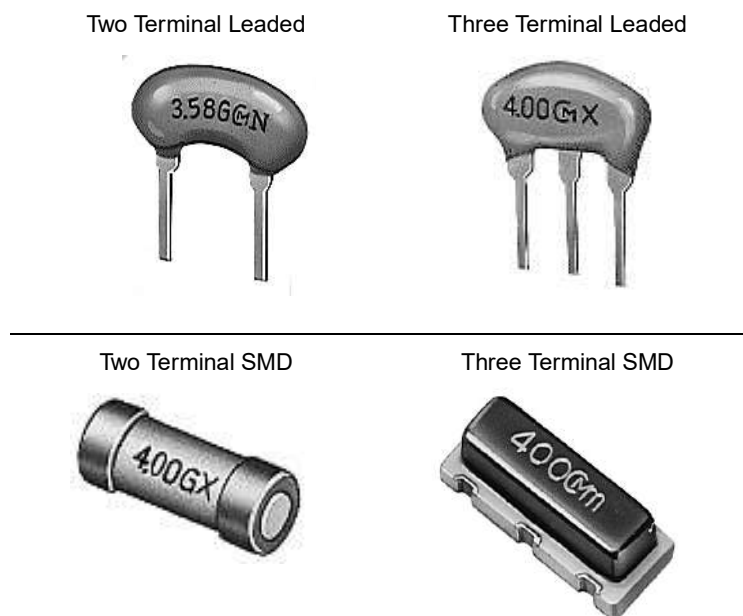

Figure 16: Two and Three Terminal Resonator

Spurious Oscillations

The odd overtones (3rd, 5th, etc. for fundamental mode resonators, or suppressed fundamental, 5th, etc. for third overtone resonators) are always present as spurious oscillations. Also, other vibration modes can cause spurious oscillation. These other vibration modes are the same ones employed to make higher frequency resonators. These can be suppressed by properly designing the hookup circuit around the resonator. Care must be taken in determining oscillator hook-up circuit to insure desired operation. Without a correctly designed oscillation circuit, undesired spurious oscillation can occur.

Resonators are designed to use one vibration mode but suffer from spurious oscillation due to other vibration modes. These can be controlled to a certain extent by using the correct value of load capacitors or dampening resistor (R_d) to suppress gain at the overtone's frequency. One of the most common spurious oscillations for kHz range resonators is a result of an undesired vibration mode, thickness vibration. This causes a hump in the frequency response around 4 –

5 MHz (Figure 17).

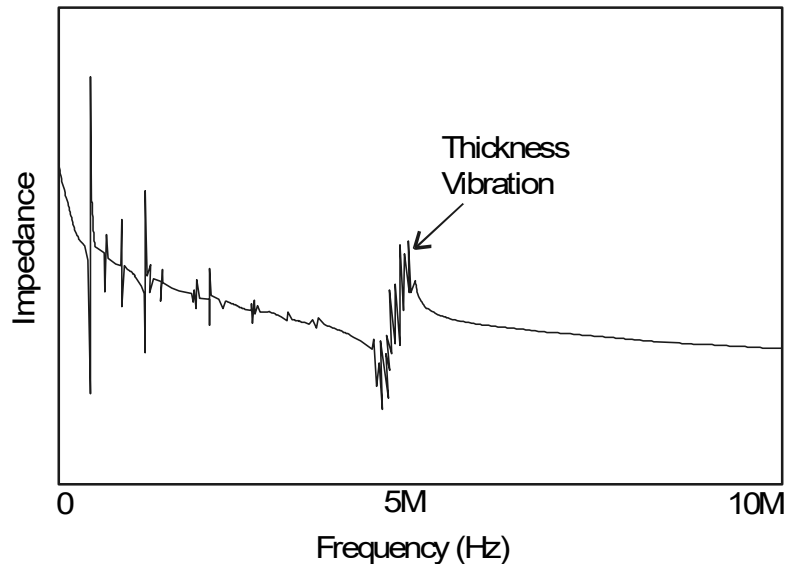

Figure 17: Impedance Response Plot of kHz Resonator Showing Thickness Vibration Spurious Response

Resonator Specifications

Nominal Oscillation Frequency

This is the oscillation frequency of the resonator measured in a specified test circuit.

Frequency Tolerance

There are three types of frequency tolerance (Initial, Temperature, and Aging) that go into the complete tolerance specification for a ceramic resonator. These tolerances are provided as a +/- percentage and are listed individually on a resonator's specification. These tolerances are all added to make the complete tolerance specification.

- *Initial tolerance*

This is how much the frequency will vary based on slight differences in materials, production methods, and other factors, at room temperature. This tolerance results from the fact that every part cannot be exactly the same. There will always be some small difference from one part to another.

- *Temperature tolerance*

This is a measure of how much the frequency varies with a change in temperature. Ceramic materials have a positive temperature coefficient. This means that as the temperature increases the resonator frequency increases. For the resonators that have built in load capacitors, since the capacitors are made of a ceramic material similar to the resonator ceramic, the value of the load capacitors increases with temperature. However, increasing the value of the load capacitors decreases the oscillation frequency, which helps to compensate for the increase of resonator frequency. For this reason, the resonators with built in load capacitors will have better temperature tolerance specifications than resonators without built-in load caps.

- *Aging tolerance*

This is a measure of how much the frequency will vary over the life of the part (typically 10 years).

Built In Capacitance Values

Indicates the built-in load capacitor value inside of the resonator and the tolerance of this capacitor's values. This only applies to resonators where their part numbers start with the "CST" (like: CST..., CSTS..., CSTCV..., etc.)

Resonant Impedance

This is a specification of the impedance occurring at f_r . Lower values for resonant impedance are desired. The lower the resonant impedance is in a given resonator, then less gain is required in the oscillation circuit for oscillation to start and continue. The specification usually list a maximum value of impedance that will not be exceeded by any resonator made to this specification.

Insulation Resistance

This is the measurement of resistance between the two terminals of the resonator at some given DC voltage. At DC, the resonator should appear capacitive and have a high resistance between the terminals. Remember, the part only achieves low impedance near its oscillation frequency, not DC.

Withstanding Voltage

Indicates the maximum DC voltage that may be applied across the outside terminals (not including ground terminal of CST type resonators) for a given time.

Absolute Maximum Voltage

- Maximum D.C. Voltage

Indicates the maximum DC voltage that can be applied to the resonator continuously.

- Maximum Input Voltage

Indicates the maximum AC peak to peak voltage that may be applied to the resonator.

Operational Temperature Range

Murata offers ceramic resonators in two different temperature ranges: Standard and Automotive.

- Standard (-20C to +80C)

Standard temperature range resonators will remain in specification over the temperature range of -20C to +80C. Exceeding this range can cause the resonator to perform outside of specification.

- Automotive (-40C to +125C)

Automotive grade resonators are exactly the same as standard resonators, except all automotive grade parts go through additional sorting to insure performance over the wider temperature range and in an automotive environment. These sorted resonators are also capable of passing the rigorous thermal cycling requirements of automotive customers. Automotive is a bit of a misnomer since automotive grade parts are not only for automotive applications, but for any application that requires an extended temperature range.

Storage Temperature range

This temperature range indicates the temperature at which the resonator can be safely stored in a non-operating condition. This range will vary depending on whether the resonator has a standard or an automotive temperature rating.

Test Circuit

The test circuit indicates the circuit used to test the resonator for compliance with specification. The ceramic resonator is sorted for 100% spec compliance in production, using this test circuit.

Comparison of Crystal and Ceramic Resonators

In the previous sections, the basic operation of a ceramic resonator has been discussed and some comparisons made to quartz crystal resonators. At this point, we should look at the differences between these two types of resonators.

There are several advantages that ceramic resonators have over quartz crystal resonators. Figure 18 shows the characteristics of ceramic and quartz crystal resonators. As can be seen, the quartz crystal has a much tighter frequency tolerance, as indicated by a smaller difference between f_a and f_r . This tighter frequency tolerance is the major advantage of quartz crystal based resonators over ceramic based resonators.

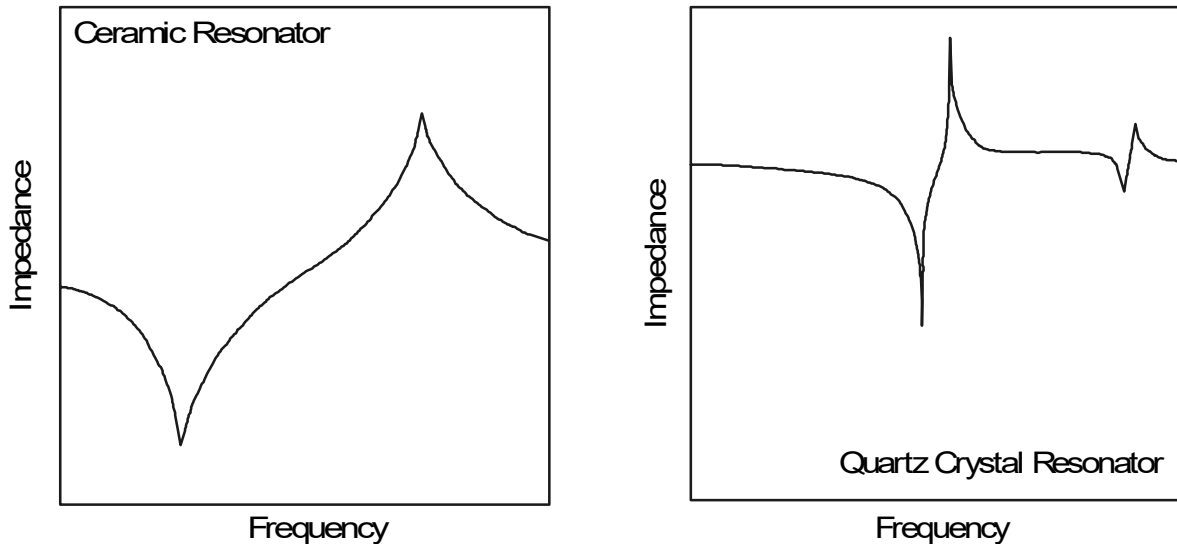

Figure 18: Impedance Response Comparison between Ceramic and Quartz Resonators

Table 1 shows a comparison of the electrical characteristics between ceramic resonators and quartz crystal resonators (**BOLD** = better, where appropriate).

	Ceramic Resonator	Quartz Crystal
Frequency Tolerance	$\pm 0.2 \sim \pm 0.5\%$	$\pm 0.005\%$
Temperature Characteristics	20 ~ 50 ppm/°C	0.5 ppm/°C
Static Capacitance	10 ~ 50pF	10pF max.
Q_m	$10^2 - 10^3$	$10^4 - 10^5$
ΔF	$0.05 \times F_{osc}$	$0.002 \times F_{osc}$
Rise Time	$10^{-5} - 10^{-4}$ Sec	$10^{-3} - 10^{-2}$ Sec
Height (leaded)	7.5mm (Typ)	13.5mm (Typ)
Price Index	1	2

Table 1. Basic Resonator Parameter Comparison Between Ceramic and Quartz Resonator

As can be seen from the table, quartz crystal resonators have a much better frequency tolerance than ceramic resonators. They have a higher mechanical Q and a smaller ΔF . For tight frequency tolerance applications, quartz crystal resonators are the choice. Ceramic resonators have a much faster rise time, smaller size, and are about half the price. In addition, ceramic resonators have a better mechanical shock and vibration resistance. They will not break as easily as quartz resonators. Drive level, a big issue with quartz crystal resonators, is not an issue with ceramic resonators. Most applications can accept the looser frequency tolerance of the ceramic resonator, while enjoying the other benefits.

Quartz crystal resonators require a LC tank circuit in order to suppress the fundamental and work with 3rd overtones, where ceramic resonators do not. This saves in cost of parts for the circuit, storing the parts, space on the board, and time needed to place the parts in production.

Design Considerations

Hook Up Circuit

While Murata strongly recommends that all customers take advantage of Murata's characterization service (see Appendix 3 and some comments later in this section), the following will provide a basic explanation of the external hook-up circuit for a ceramic resonator and what effect each component in the hook up circuit has to oscillation.

Figure 19 shows a basic oscillation circuit using a CMOS inverter (you can use a HCMOS inverter for higher frequency oscillators). For oscillation circuits using inverters, it is not recommended to use buffered inverters. Unbuffered inverters are desired since they have less gain, which decreases the chance for spurious overtone oscillation.

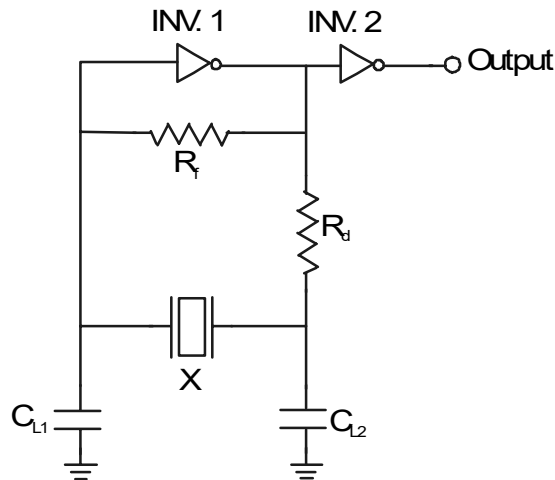

Figure 19: Typical Hook-up Circuit for Ceramic Resonator

INV. 1 is simply an inverting amplifier and is the active component of the oscillation circuit. INV. 2 is used as a waveform shaper (makes the sinusoidal output of INV. 1 into a square wave) and a buffer for the output. It squares off the output signal and provides a clear digital signal.

- R_f

R_f provides negative feedback around INV. 1 so that INV. 1 works in its linear region and allows oscillation to start once power is applied. If the feedback resistance is too large and if the insulation resistance of the inverter's input is decreased then oscillation will stop due to the loss of loop gain. If it is too small then the loop gain will be decreased and it will adversely effect the response of the fundamental and 3rd overtone response (could lead to 5th overtone oscillation). A R_f of 1 M Ω is generally recommended for use with a ceramic resonator, regardless of resonator frequency.

- R_d

The damping resistor, R_d has several effects. First, without R_d , the output of the inverter sees the low impedance of the resonator. This low impedance of the resonator causes the inverter to have a high current draw. By placing R_d at the output of the inverter, the output resistance is increased and the current draw is reduced. Second, it stabilizes the phase of the feedback circuit. Finally, and most importantly, it reduces loop gain at higher frequencies. This is very helpful when dealing with a high gain inverter / clock circuits. If the gain is too high, the chance for spurious oscillations is greatly increased at the resonator's overtones or other vibration modes (i.e. high frequencies). R_d works with C_{L2} to form a low pass filter, which minimally effects gain at the fundamental frequency, while greatly effecting gain at higher frequencies. This is one tool for removing unwanted overtone or spurious oscillations.

- Load Capacitors

The load capacitors, C_{L1} and C_{L2} , provide a phase lag of 180^o as well as determine controlling frequency of oscillation. The load capacitor values depend on the application, the IC, and the resonator itself. If the values are too small, then the loop gain at all frequencies will be increased and could lead to spurious overtone oscillation. This is particularly likely around 4 – 5 MHz where the thickness vibration mode lies with kHz resonators. For MHz resonators, the spurious oscillation is likely to occur at the 3rd harmonic frequencies (even with 3rd overtone MHz resonators). If the resonator circuit is oscillating at a substantially higher frequency, then increasing the load capacitor may solve the problem. *Changes in load capacitance effect gain at all frequencies (unlike R_d). Increase load cap values to cut gain, decrease load cap values to boost gain, for all frequencies.

***Please Note:** As mentioned above, the resonator itself can effect which load capacitor values should used in any given oscillation circuit. This is important to note, when comparing ceramic resonators, from various ceramic resonator

manufacturers, in an oscillation circuit. Since the ceramic material used to make the resonator is a little different from manufacturer to manufacturer (thus the equivalent circuit of the resonator is slightly different), it is very common to see one manufacturer's resonator need certain load cap value in an oscillation circuit, but another manufacturer's resonator needs another load cap value for stable oscillation (in the same circuit). Also, the sorting IC (test circuit used in production) used to determine oscillation frequency (to resonator specification) can also differ by resonator makers. Do not assume that if you get a supplier "A"'s resonator to work with a given load cap value, that supplier "B"'s resonator will need same load cap value.

Also be aware that if load cap values / IC combination works at one frequency, the load caps may need to be different for the same IC at other frequencies. By using Murata's free IC characterization service (later in this section or see Appendix 3), such problems and concerns can be completely avoided in your design.

- Test Circuit Types

The circuit in Figure 19 is the standard test circuit used by Murata on all of our resonators. We use an unbuffered CMOS chip (RCA/Harris CD4069UBE), an unbuffered HCMOS (Toshiba TC40H004P) or an unbuffered HCMOS (Toshiba TC74HCU04) chip as a reference for all of the published specifications. The test circuit used is indicated on the data sheet for the part. CMOS is typically used with lower frequency resonators while HCMOS is used with the higher frequency resonators. The resonator part number calls out which type of CMOS inverter is used. Please see the section on resonator part numbering for clarification of this point. Appendix 2 gives the standard test circuit values for Murata's resonators

Irregular Oscillation

As mentioned in the section on "Spurious Oscillation", spurious oscillations can sometimes occur if the hook-up circuit is not designed correctly for the resonator and target IC. Spurious oscillation is basically any oscillation not occurring at the resonator's specified oscillation frequency (for example: a 4MHz resonator is used, but the circuit oscillates at 12MHz). Table 2 lists the possible causes for spurious oscillation for various frequency ranges of resonators.

General Resonator Series	Frequency Range	Vibration Mode	Possible Cause of Irregular Oscillation	
			Type 1 (Spurious Response)	Type 2 (Other)
CSB	375k - 580kHz	Area	3rd Overtone, Thickness vibration (at 4.3MHZ)	CR Oscillation LC Oscillation Ring Oscillation
	581k - 910kHz	Area	3rd Overtone, Thickness vibration (at 5.7MHZ)	
	911k - 1250kHz	Area	3rd Overtone, Thickness vibration (at 6.5MHZ)	
CSA-MK	1.26M - 1.79MHz	Shear	3rd Overtone (not common)	
CSA-MG CST-MG	1.80M - 1.99MHz	Thickness Shear	3rd Overtone (not common)	
CSA-MG CSTLS-G	2.00M - 3.39	Thickness Shear	3rd Overtone (not common)	
CSA-MG CSTS-MG	3.40M - 10.00MHz	Thickness Shear	3rd Overtone (not common)	
CSA-MTZ CST-MTW	10.01M - 13.00MHz	Thickness Longitudinal	3rd Overtone (not common)	
CSA-MXZ CST-MX	13.01M - 15.99MHz	Thickness Longitudinal Third Overtone	Fundamental and 5th Overtone	
CSALS-MX CSTLS-X	16.00 - 70.00MHz	Thickness Longitudinal Third Overtone	Fundamental and 5th Overtone	

Table 2. Possible Causes of Irregular Oscillation

Irregular oscillations can be classified into two basic type by their causes:

Type 1: Oscillation occurring at the spurious response of the resonator.

Type 2: RC, LC, or Ring oscillation.

Type 1 Irregular (Spurious) Oscillation

For ceramic resonators utilizing natural 3rd overtone operation, a greater chance is present for fundamental and 5th overtone spurious oscillations. If a LC tank circuit is used (like with quartz resonators) the chance for spurious oscillations is almost zero. However, Murata 3rd overtone resonators are designed to not need an external tank circuit. For kHz resonators that have problems with third overtone or thickness vibration mode spurious oscillations, the solutions for 5th overtone oscillations mentioned below can correct these spurious oscillations as well.

Fundamental Oscillation

Increasing the loop gain at the 3rd (main) response, decreasing loop gain at the fundamental, and decreasing the phase shift at the fundamental are possible solutions to fundamental spurious oscillations

- Decrease the load capacitor capacitance. This will increase the gain seen at the main response (3rd). Decreasing load capacitance too much can result in 5th overtone oscillation.
- Decrease R_f to a few k Ω (10k Ω - 30k Ω). This will dump the resonator's response, especially at the fundamental.

5th Overtone Oscillation

To remove 5th overtone oscillation (or 3rd overtone oscillation for fundamental resonator), it is necessary to decrease the loop gain at this overtone.

- Increase the value of the load capacitors. This will reduce gain at the 5th overtone (or 3rd overtone for fundamental resonators). This does have the small effect of decreasing gain at the main response, so increasing load capacitance too much can send the 3rd overtone resonator in to fundamental oscillation (or the fundamental into an unexpected LC or RC oscillation).
- Add or increase the value of the existing R_d resistor. Increasing or adding R_d will decrease gain across all frequencies. If an oscillation circuit has abundant gain at the main (or fundamental) response, then the circuit could withstand increase to R_d in order to dampen the overtone oscillation. Also, R_d and C_{L2} act like a low pass filter, dampening gain at higher frequencies.
- Connect bypass capacitors to the voltage supply pin of the IC to remove high frequency noise during power up of the oscillation circuit.

Type 2 Irregular (Spurious) Oscillation:

In the case of type 2 spurious oscillation, the resonator is acting like a capacitor at a capacitance value close to the resonator's shunt capacitance, C_o . For RC spurious oscillation, the resonator's shunt capacitance and the amplifier's (or inverter's) input impedance act like a RC circuit causing unwanted oscillation. For LC spurious oscillation, the resonator's shunt capacitance and stray inductance in the circuit act like a LC circuit causing unwanted oscillation.

These types of spurious oscillations are hard to identify, since this spurious oscillation usually occurs at very high or very low frequencies (not near the intended oscillation frequency). Many resonator circuits that appear not to oscillate at resonator's specified oscillation frequency (circuit appears to be dead, no oscillation) are actually oscillating at a very high frequency in a spurious oscillation mode. One way to confirm that this type of spurious oscillation is occurring is to replace the resonator with a capacitor of the same value as the resonator's shunt capacitance. If the circuit continues to have the same frequency oscillation after the resonator / capacitor swap, then the oscillation can be attributed to LC or RC oscillation.

A common cause of RC, LC, or ring oscillation is too much amplifier gain, most notably from using buffered inverters. A buffered inverter is typically three non-buffered inverters in series. Because of this, buffered inverters have a considerable amount of gain, resulting in these types of spurious oscillations. Murata recommends only using unbuffered inverters for oscillation circuits using ceramic resonators. Most clock circuits in current ICs use unbuffered type inverters. You can still feed the output of the unbuffered oscillation circuit into another unbuffered inverter to square up the output waveform from the oscillation circuit.

Ring oscillation typically occurs when there is too much phase shift through the amplifier (or inverter). Ring type oscillation really only occurs when using the unrecommended buffered inverter as the amplifier. Due to the three inverter stages in a buffered inverter, a substantial amount of phase delay is introduced to the circuit, causing the ringing. To stop ring oscillation, switch to an unbuffered inverter.

If changing to a unbuffered inverter does not stop the type 2 oscillation (or you are already using an unbuffered inverter), we must try alternate techniques to make these spurious oscillation no longer meet Barkhausen Criterion for oscillation. The following may be used to do this:

- Try changing the load capacitor values. By increasing the load capacitor values, the high frequency circuit gain is reduced without major impact to the gain at fundamental. Increasing load caps too much can result in the circuit not being able to oscillate even at the fundamental response.
- Try unbalancing the load cap values. For most applications, the two load capacitors are basically the same value. Having load capacitors at two different values can sometimes correct type 2 spurious oscillations.
- Try adding a R_d or increasing R_d (if already present in the oscillation circuit). R_d has the effect of decreasing circuit gain across all frequencies (unlike changing load capacitor values). This is a more drastic method, since the gain at the fundamental response is decreased as well as gain at the spurious oscillations.
- Try adding a bypass capacitor to the power line to the IC to remove any external noise coming into the oscillation circuit.

IC Characterization Service

The ceramic resonators produced by Murata (or any ceramic resonator maker) may or may not work with all ICs using standard external circuit values. This is mainly due to typical variations in ICs and resonators, part to part. In order to assist our customers with their designs, Murata offers a resonator / IC characterization service free of charge. The customer's IC is tested with the Murata resonator. Measurements are made to determine frequency correlation between the standard sorting ICs Murata uses in production and the customer's IC. Based on test results and Murata's long experience with ceramic resonators / oscillation circuits, Murata provides the recommended Murata part number that should be used with their target IC and the recommended external hook up circuit for this target IC. This recommendation insures that the IC / resonator combination will have stable oscillation and good start up characteristics (taking into account any resonator that could be shipped to the resonator specification) This enables the designers to adjust their designs so that the resonator will work every time. These adjustments can be as simple as adjusting component values or as complicated as redesigning the entire circuit. If the recommendations made by Murata are followed then the resonator is guaranteed to work every time. Besides looking at oscillation stability, Murata can also test for frequency correlation between customer target IC and Murata's production sorting circuit.

Murata Electronic Sales representatives are able to arrange IC characterizations. Please try to start the IC characterization process with Murata as soon as possible, since it does take time to do an IC characterization and there can be several customers at any one time waiting for this service.

Please see Appendix 3 for more information on this service and needed forms.

Characteristics of Oscillators Using A Ceramic Resonator

The next sections explain some of the characteristics of oscillation circuits using ceramic resonators.

Oscillation Rise Time

The rise time is the time it takes for oscillation to develop from a transient area to a steady state area at the time the power is applied to the circuit. It is typically defined as the time to reach 90% of the oscillation level under steady conditions. Figure 20 illustrates the rise time.

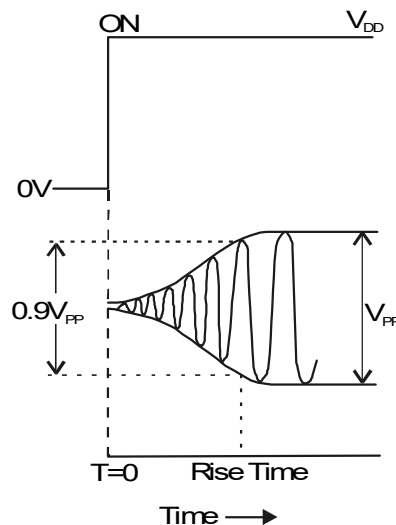

Figure 20: Diagram of Oscillation Rise Time

This area is important because without a fully developed signal, mistakes could be introduced into the digital computations in the IC. An ideal circuit would have no rise time, meaning that it would instantaneously power up and reach steady oscillation. An advantage of ceramic resonators is that the rise time is one or two decades faster than quartz

crystal (Figure 21).

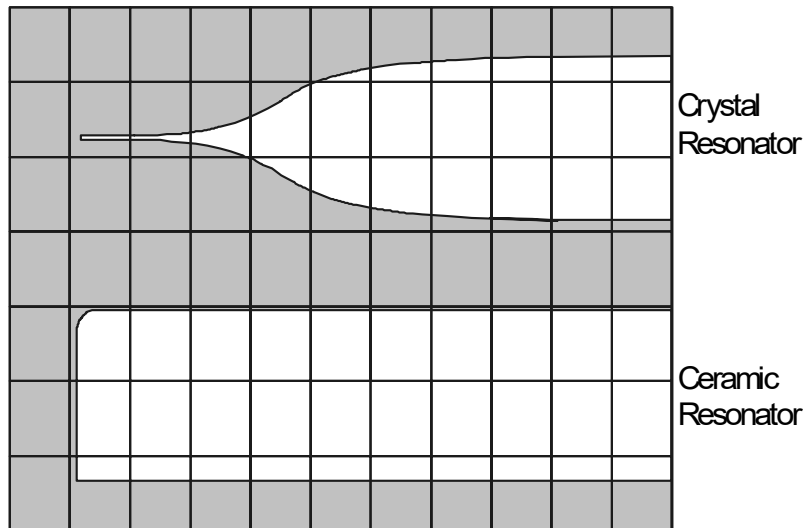

Figure 21: Comparison of Oscillation Rise Time Between Ceramic Resonator and Quartz Crystal Resonator

Starting Voltage

The starting voltage is the minimum supply voltage at which an oscillating circuit will begin to oscillate. The starting voltage is affected by all circuit elements but is determined mostly by the characteristics of the IC.

Speciality Resonator Applications

Telephone (D.T.M.F)

It is becoming more and more common to use the telephone keypad for data transmission. It is used to make selections on automated answering systems, for example. It is also becoming more important to ensure that the button pressed will be registered as the corresponding number by the receiving end. When a telephone key is pressed, a certain audible frequency is generated representing that key. It is critical that the frequency generated is accurate, so the receiving end understands what key was pressed. For this reason, a global regulation calls for a mandatory frequency tolerance. The total allowable frequency tolerance for the oscillation of a tone dialer for a telephone is $\pm 1.5\%$. This tolerance is for the IC as well as the resonator, not just the resonator alone. Table 3 shows how the tolerance is divided up between the IC and the resonator.

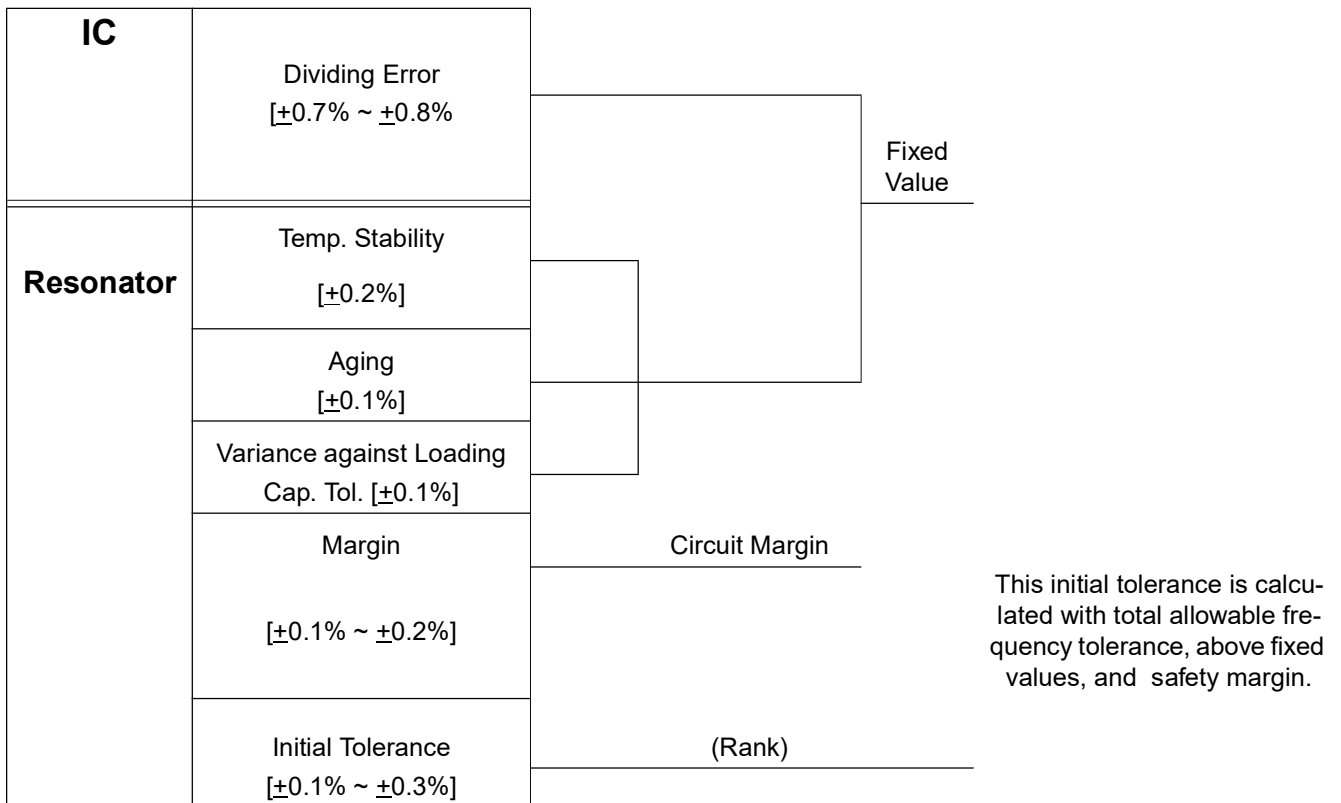

Table 3. DTMF Tolerance Chart

The typical resonator frequency used is 3.58MHz. This frequency is divided by the IC to generate the lower frequency audible tones associated with each key press. The dividing error is related to the IC that is used in the circuit and so is a fixed value. This value will usually be specified on the data sheets for the IC. Aging of the resonator is also a fixed value. The other values can be changed by changing the design of the resonator. Murata has developed a way to account for the different tolerance specifications on our parts. We add a postscript to

the part numbers based on the chart in Figure 22.

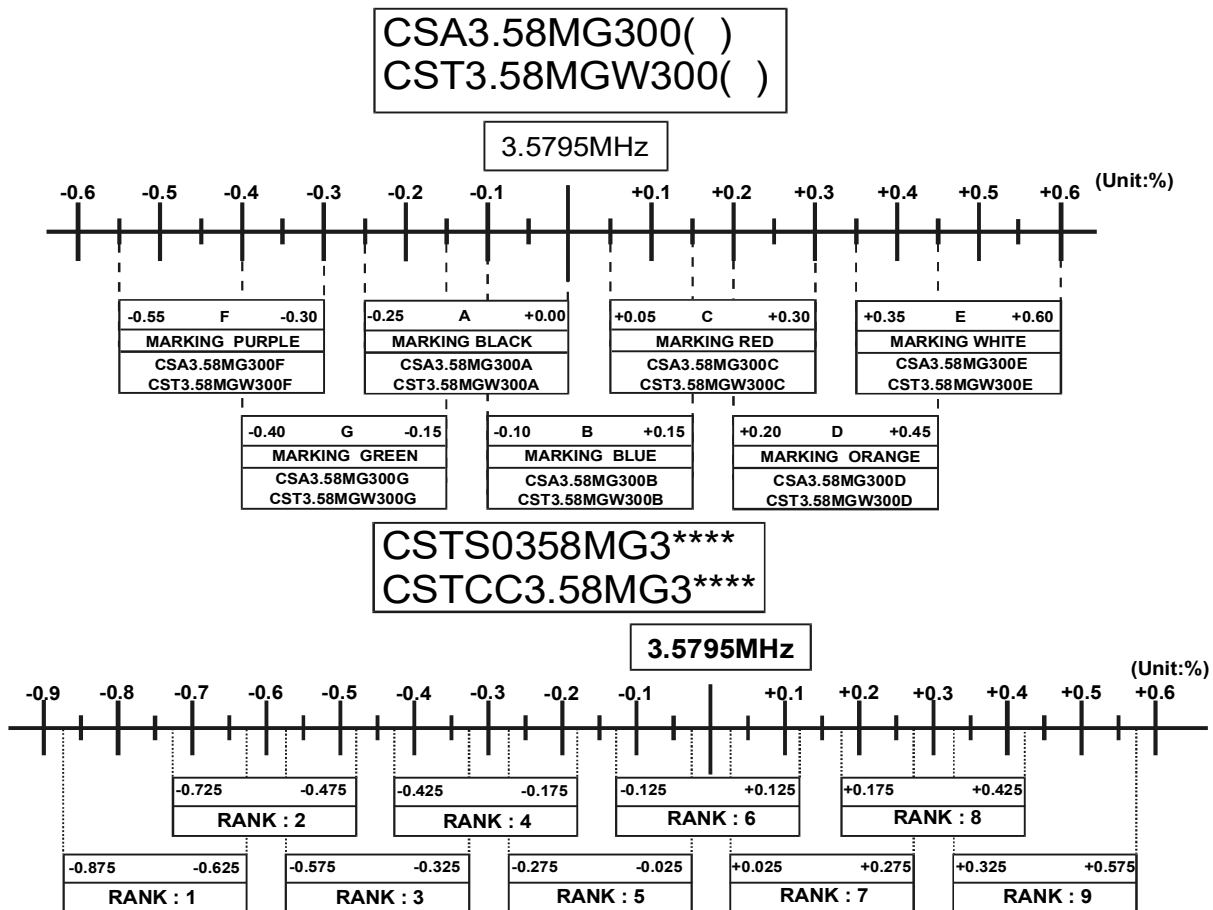

Figure 22: DTMF 3.58MHz Resonator Tolerance Chart

For example, a part with a tolerance of $\pm 0.1\%$ would have ABC at the end of its part number. Murata is able to produce resonators with asymmetrical tolerances (i.e. $+0.1\%$, -0.2%) and this convention provides an easy way to label the parts.

Resonators for various commercially available DTMF ICs have already been characterized by Murata and resonator part number recommendation are available. If a particular DTMF IC has not been characterized yet by Murata, this can be handled in the same way as the common IC characterization service Murata provides.

Voltage Controlled Oscillator (VCO) Circuits

VCO circuits are used in TV and audio equipment to process signals in synchronization with reference signals transmitted from broadcasting stations. They use a DC input voltage to change the frequency of oscillation. For example, if a VCO operates at 4 MHz with a 0V DC input, then it might operate at 4.01MHz with a 1V DC input. VCOs work by varying either the resonant or anti-resonant frequencies of the resonator. To change the resonant frequency, a varactor diode is placed in series with the resonator. Changing the capacitance of the diode changes the resonant frequency of the resonator. Adding positive or negative reactance in parallel with the resonator will change the anti-resonant frequency.

Since ceramic resonators have a wide ΔF compared to quartz crystal, they are more easily used in VCO designs. The wider ΔF allows for a greater range of frequencies the resonator can be changed to. Two examples of VCO applications are TV horizontal oscillator circuits and stereo multiplexer circuits.

Like the DTMF ICs, Murata has many of the ICs requiring VCO resonators already characterized. If an IC has not been characterized with a Murata resonator, then an IC characterization will need to be performed.

Part Numbering

This section will go over Murata part number construction and how to make a ceramic resonator part number. Due to the myriad of resonator part numbers possible, this section will not cover every possible part, but should cover at least 85% to 90% of them. Figures 23 and 24 show examples of the structure for the Murata part numbering systems for the kHz and MHz resonators.

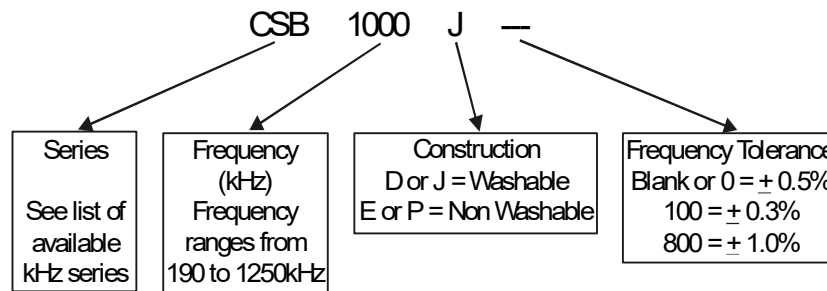

Figure 23: kHz Part Numbering System

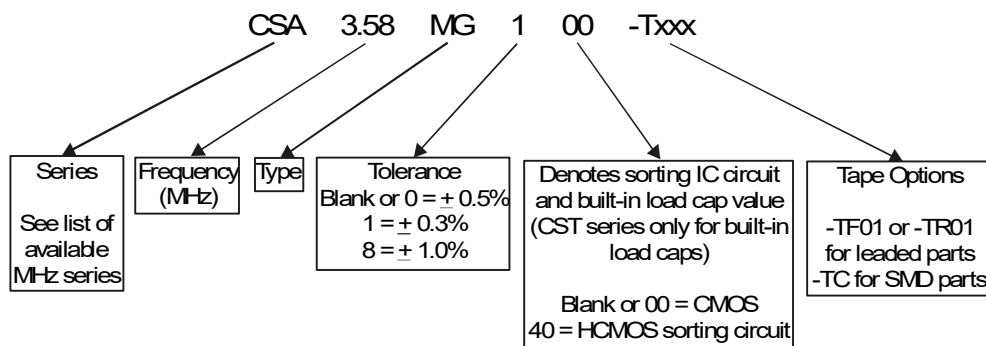

Figure 24: MHz Part Numbering System

How To Make a Resonator Part Number.

This next section will step you through making a Murata ceramic resonator part number.

- Determine Resonator Series

Table 4 lists the different resonator series offered by Murata. In the table for each listed series, we advise applicable frequency range, built-in load cap status, if the part is SMD or leaded, and if the part is washable. Please note that the second part of Table 4 list those resonators available in the automotive temperature range (adds an "A" to the suffix).

- Make the Base Part Number

From Table 4, you have picked your series. The Resonator Series column in Table 4 indicates the part prefix and suffix. Between the prefix and suffix, you need to add the frequency (where you see the "..."). You will note that SMD parts already have the taping suffix attached since SMD parts are only supplied on tape and reel (bulk SMD parts is not an option).

- Add the Frequency

Based on the series selected, the Frequency Range column will advise available frequency range

Frequency Rules:

- 1) kHz filters can have either 3 or 4 digits total, with no decimal places. (Example: 455 or 1000, but not 355.6 or 10.00)
- 2) MHz MG resonators can have three digits total, with two decimal places. (Example: 3.58 or 6.00, but not 3.586)
- 3) MHz MT resonators can only have three digits total, with one or two decimal places. (Example: 8.35 or 10.5, but not 8.356 or 10.55)

4) MHz MX resonators can only have 4 digits total, with two decimal places. (Example: 15.00, 55.25, but not 20.386 or 50.4567)

- Taping

For SMD parts, the series already includes the taping. Leaded kHz resonators do not have a taping option. We can supply some leaded kHz filters in tubes, but you will need to confirm availability with Murata.

For leaded MHz resonators, the parts can be supplied on tape and ammo box (-TF01, our standard and most available taping option for leaded resonators) or tape and reel (-TR01).

- Conclusion

For 80% of the part numbers, you are done making your part number by this step. The only additional options you may need to pick is initial frequency tolerance (MHz and kHz resonator, see Figures 23 and 24), IC sorting circuit (see Figures 23 and 24), and any additional suffixes (including resonators for VCO and DTMF applications).

- General Part Numbering Rules

Here is a list of general part number rules, that really do not fit into the above instructions:

1) A resonator will never have a suffix with “000” in it. This suffix calls out (first digit) initial frequency tolerance and (last two digits) IC sorting circuit / built-in load cap values. If this final suffix turns out to be “000” (with or without taping suffix), the “000” is dropped completely (Example: CSA4.00MG and CSA4.00MG-TF01 correct, CSA4.00MG000 and CSA4.00MG000-TF01 incorrect).

Resonator Series	Frequency Range (Hz)	Load Caps Included	SMD	Washable
CSB...P	375k - 429k & 510k - 699k	N	N	N
CSB...E	430k - 509k	N	N	N
CSB...J	375k - 429k & 430k - 519k & 520k - 589k & 656k - 699k & 700k - 1250k	N	N	Y
CSB...JR	590k - 655k	N	N	Y
CSA...MK	1.26M - 1.799M	N	N	Y
CSA...MG	1.80M - 6.30M	N	N	Y
CSA...MTZ	6.31M - 13.0M	N	N	Y
CSA...MXZ	13.01M - 15.99M	N	N	Y
CSALS-X	16.00M - 70.00M	N	N	Y
CST...MG	1.80M - 1.99M	Y	N	Y
CSTLS-G	2.00M - 3.39M	Y	N	Y
CSTS...MG	3.40M - 10.00M	Y	N	Y
CST...MTW	10.01M - 13.0M	Y	N	Y
CST...MXW040	13.01M - 15.99M	Y	N	Y
CSTLS-X	16.00M - 70.00M	Y	N	Y
CSBF	430k - 1250k	N	Y	Y
CSAC...MGC-TC	1.80M - 6.00M	N	Y	Y
CSAC...MGCM-TC	1.80M - 6.00M	N	Y	Y
CSACV...MTJ-TC20	6.01M - 13.0M	N	Y	Y
CSACV...MXJ040-TC20	14.00M - 20.00M	N	Y	Y
CSACW...MX01-TC	20.01M - 70.00M	N	Y	Y
CSTCC...MG-TC	2.00M - 3.99M	Y	Y	Y
CSTCR-G-R0	4.00M - 7.99M	Y	Y	Y

Table 4. Available Resonator Frequencies by Series (Package)

CSTCC...MG-TC	8.00M - 10.00M	Y	Y	Y
CSTCV...MTJ-TC20	10.01M - 13.0M	Y	Y	Y
CSTCV...MXJ0C4-TC20	14.00M - 15.99M	Y	Y	Y
CSTCW...MX03-T	16.00M - 60.00M	Y	Y	Y
<i>Automotive ("A" suffix.)</i>				
CSB...JA	375k - 1250k	N	N	Y
CSBF...JA	430k - 1250k	Y	N	Y
CSA...MGA	1.80M - 6.30M	N	N	Y
CSA...MTZA	6.31M - 13.0M	N	N	Y
CSA...MXZA040	13.01M - 15.99M	N	N	Y
CSALS-X-A	16.00M - 70.00	N	N	Y
CST...MGA	1.80M - 1.99M	Y	N	Y
CSTLS-G-A	2.00M - 3.39M	Y	N	Y
CSTS...MGA	3.40M - 10.00M	Y	N	Y
CST...MTWA	10.01M - 13.0M	Y	N	Y
CST...MXWA040	13.01M - 15.99M	Y	N	Y
CSTLS-X-A	16.00M - 70.00M	Y	N	Y
CSAC...MGCA-TC	1.80M - 6.0M	N	Y	Y
CSAC...MGCMA-TC	1.80M - 6.0M	N	Y	Y
CSACV...MTJQA-TC	6.01M - 13.0M	N	Y	Y
CSACV...MXAQ-TC	13.01M - 70.00M	N	Y	Y
CSTCC...MGA-TC	2.0M - 3.99M	Y	Y	Y
CSTCR-G-A-R0	4.00M - 7.99M	Y	Y	Y
CSTCC...MGA-TC	8.00M - 10.00M	Y	Y	Y
CSTCV...MTJQA-TC	10.01M - 13.0M	Y	Y	Y
CSTCV...MXAQ-TC	13.01M - 70.00M	Y	Y	Y

Table 4. Available Resonator Frequencies by Series (Package)

The parts may have an additional suffix that refers to a special aspect of the part. Table 5 gives a list of these suffixes.

Suffix	Meaning
A	For Automotive
B	Bent Lead Type
F	For V.C.O Applications
3xx	DTMF part, usually at frequency of 3.58MHz, leaded or SMD.
P	Custom marking on part
Sx	Short Lead Type (std. = 5.0 ± 0.5mm)
	S = 3.8 ± 0.5mm
	S1 = 3.5 ± 0.5mm
	S2 = 3.4 ± 0.5mm
T	Lead Forming Type (Gull Wing Style)
U	Low Supply Voltage
Yx	Additional Color Dot (Top Left) Must check with Murata for availability.
	Y0 = Black Y5 = Green
	Y1 = Brown Y6 = Blue
	Y2 = Red Y7 = Purple
	Y3 = Orange Y8 = Gray
	Y4 = Yellow Y9 = White

Table 5. Resonator Part Number Suffix

The CSTS series and the CSACW/CSTCW series follow the part numbering system in Figure 25. Although the system includes numbers for several values of load capacitors, currently only 15pF and 47pF values are available for the CSTS series, and 5pF and 15pF values are available for the CSTCW series.

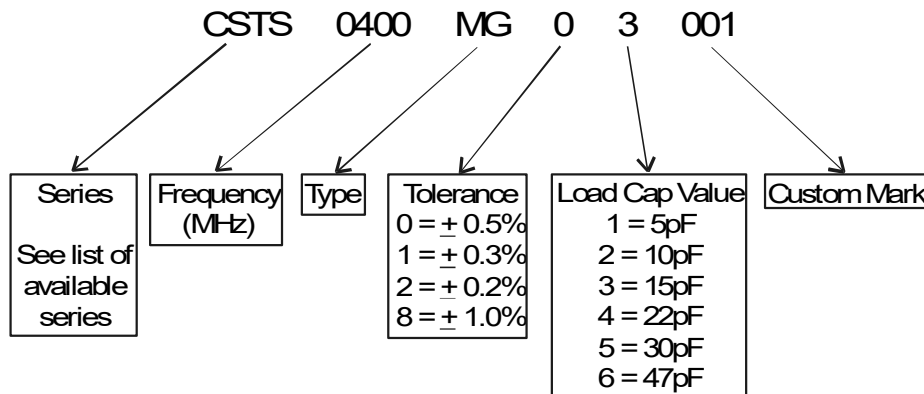
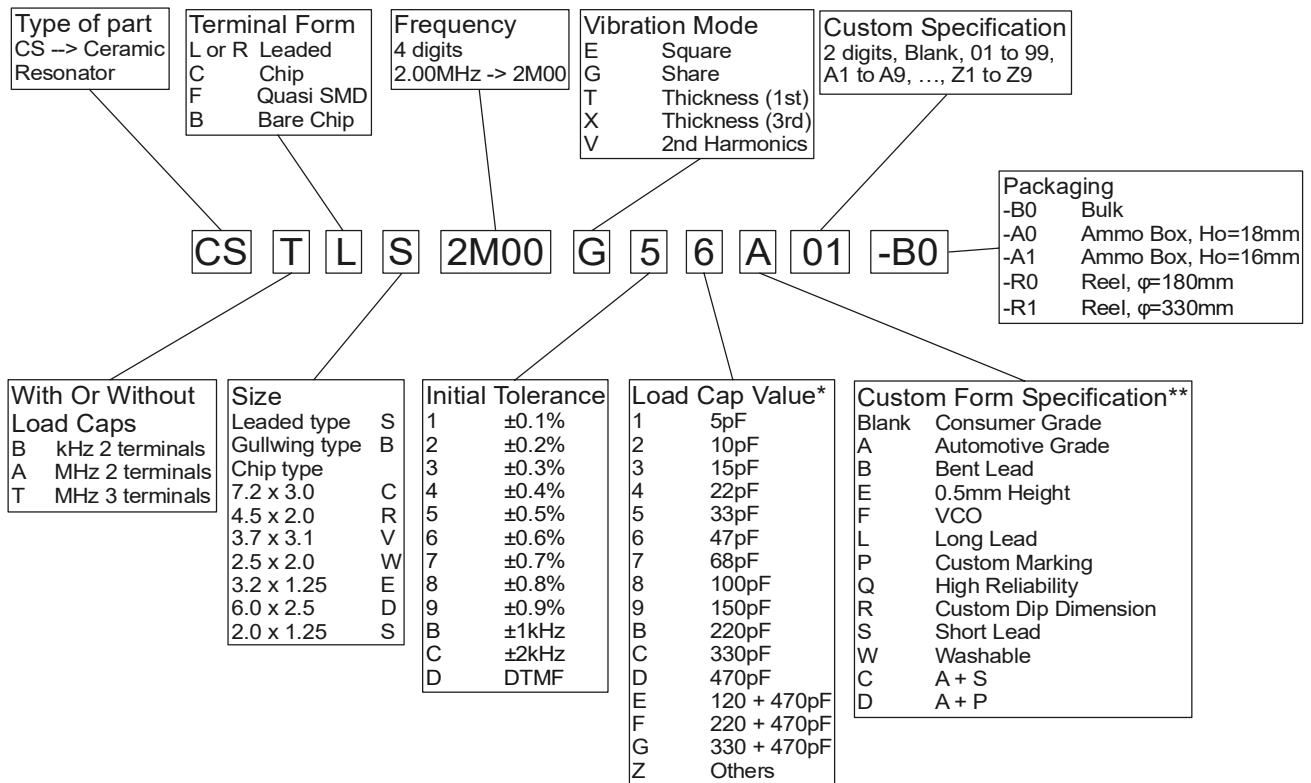

Figure 25: Resonator Part Numbering System

Beginning in the summer of 2000, a new global part numbering system will be implemented by Murata. All resonators introduced in 2000 and later will follow this part numbering system, and some current resonators will be switched to this

system.



* Note: Not all load cap values available with a specific part. In the case of 2 terminal resonators, cap value is for Murata standard circuit. In the case of 3 terminal resonators, cap value is for built-in capacitors.

** Note: Not all custom forms are available with a specific part.

Figure 26: New Resonator Part Numbering System

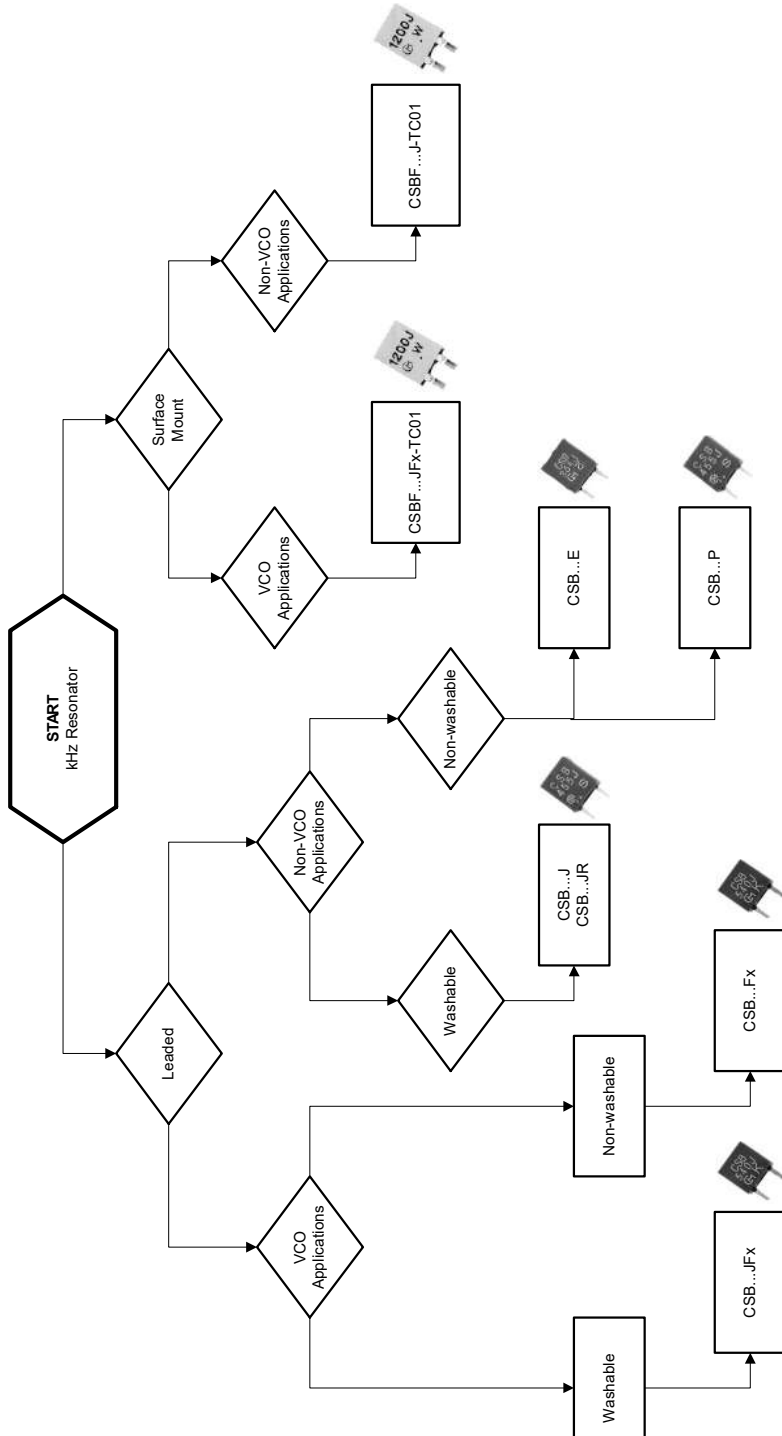

Figure 27: kHz Resonator Selection Guide

x represents a number that calls out the IC that this part works with. VCO resonators are IC specific so only work with certain IC chips.

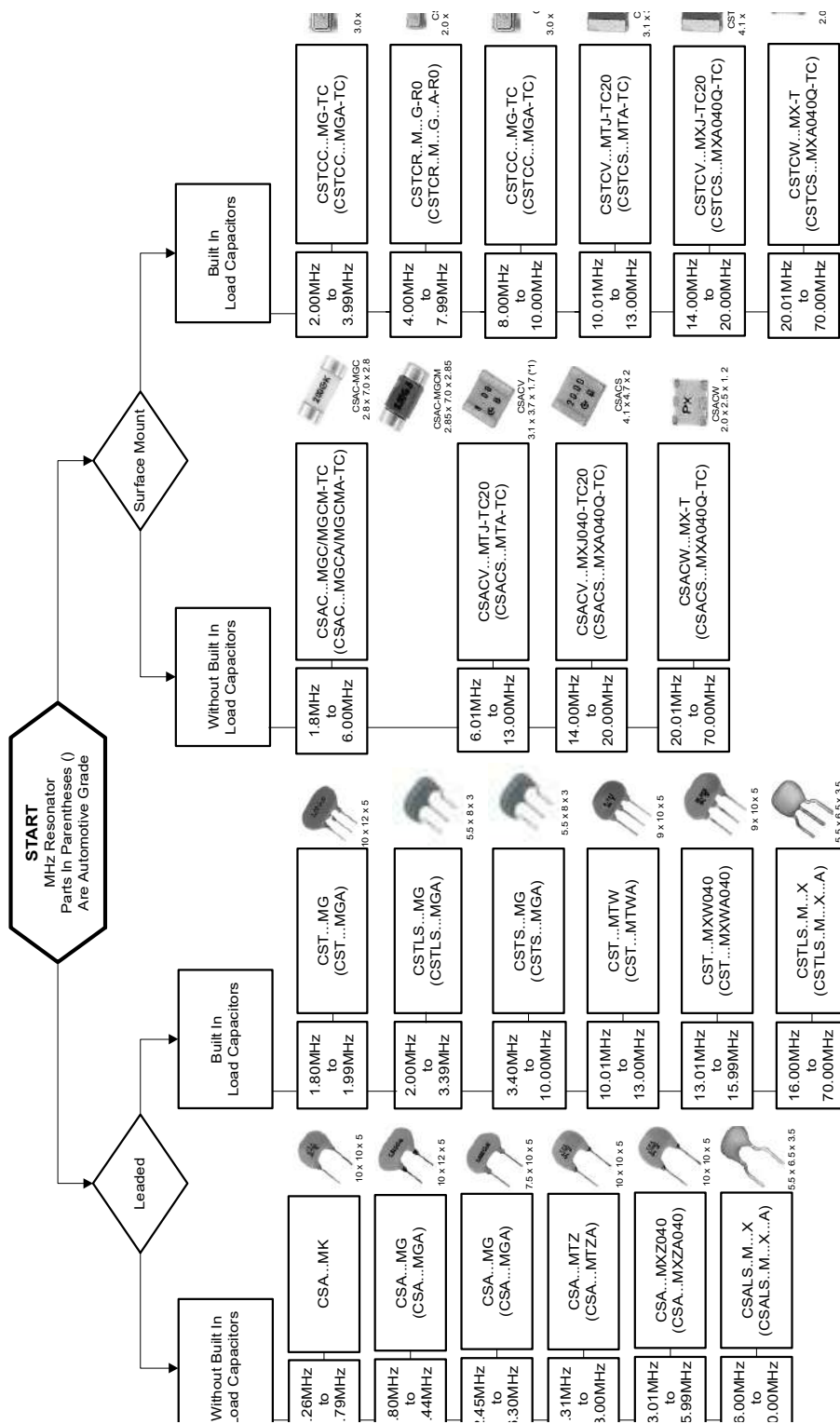

Figure 28: MHz Resonator Selection Guide

OTE: Part dimensions are H x W x T in mm
1) Thickness varies with frequency and load capacitance

Piezoelectric Filters

Introduction

As you may know, we are constantly surrounded by all sorts of radio frequencies. From audio range frequencies that we can hear to very high frequencies that are visible as light, our electronics and we are constantly being immersed in these frequencies. It is the job of a band pass filter to pick out only the range of frequencies desired for the intended application.

Ideally, when an inputted signal (say from an antenna) goes through a band pass filter, all frequencies that are within the bandwidth (“pass-band”) of the filter will be allowed to pass through the filter. Those frequencies above or below the pass-band region (in the “stop-band”) will be attenuated (or rejected) at some fixed value (determined by the filter) and thus will not be seen at the output of the filter. Figure 29 visualizes the effect of an ideal band-pass filter.

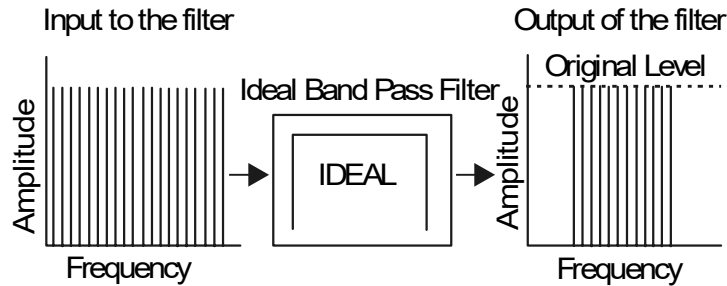

Figure 29: Ideal Band Pass Filter

As you can see in Figure 29, all frequencies are allowed to enter the filter but only those frequencies within the pass-band are allowed to exit the filter unattenuated (or unaffected).

One would expect that the band of frequencies passed by the filter would leave the filter unaffected, but this is not the case for a practical band-pass filter. There are many parasitic losses associated with a practical band-pass filter, such as insertion loss, ripple, and non-ideal roll off. Figure 30 visualizes the effect of a practical band-pass filter on a signal.

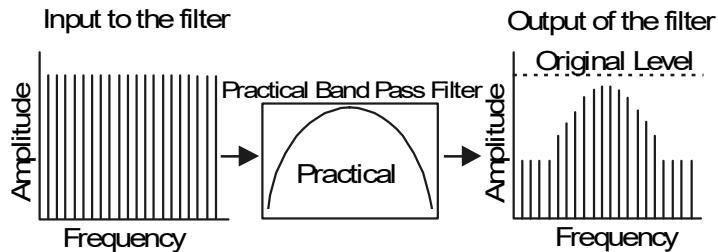

Figure 30: Practical Band Pass Filter

As you can see from comparing Figure 29 to Figure 30, the output of the filter is quite different. First you will notice that the signal level of the output signal in Figure 30 is less than the original signal level. This is due to the inherent loss (or insertion loss) of the filter. You will also notice that the sides of the pass-band in Figure 30 are not vertically straight, as in Figure 29. Practical filters, as in Figure 30, can not achieve such performance. The response will always look rounded. Very selective filters will have roll off approaching that of an ideal filter, but will trade off performance in other key filter performance parameters.

One very important parasitic effect not shown in Figure 30 is Group Delay Time (GDT). The next section will cover this important effect.

Group Delay Time (GDT)

For this discussion we are only concerned with the effect of GDT on the frequencies being allowed to pass through the band pass filter. We are looking at this characteristic specifically since it is the hardest to understand.

In a practical band-pass filter, the filter actually causes the passed frequencies to be delayed slightly in time as they pass through. The delay time is not constant across the pass-band and the frequencies end up being delayed by differing amounts of time. Frequencies occurring close to the center frequency of the filter are delayed the least while frequencies closer to the edges of the pass-band are delayed more. This delay effect is referred to as Group Delay Time (GDT). Since the frequencies are effected in time, the phase of the frequencies in relation to each other is changed. Hence, the term phase delay is sometimes used as a synonym to GDT. Figure 31 visualizes this delay effect.

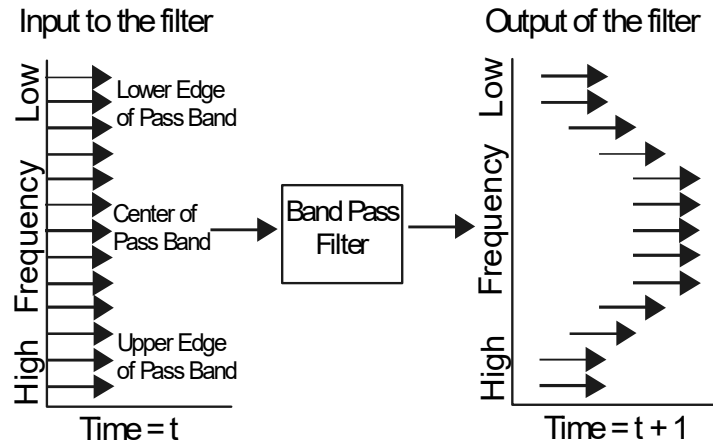

Figure 31: Group Time Delay

In Figure 31, we see a series of frequencies (we will only look at frequencies occurring within the pass-band of the filter, even though other frequencies are entering the filter as well) just prior to entering the filter. The frequencies are all aligned at the same point in time. Think of this like a horse race and each arrow (representing a frequency) is a horse. At time "t", all of the horses are at the starting gate. The race starts and the horses / frequencies enter the filter. At the end of the race (time now equals "t+1", or some time in the future), as shown at the "output of the filter" in Figure 31 above, the horses / frequencies that traveled near the center of the filter's pass band leave the filter first. Those horses / frequencies near the upper and lower edges of the filter's pass-band are delayed compared to the horses / frequencies at the center. The horses / frequencies at the pass-band edges have been delayed in time. This means that the filter imparts some time delay to frequencies in the pass-band. This effect can be considered a form of distortion since the filter is modifying the frequencies it should pass. Ideally, the filter should not effect the signal in the pass band at all. In purely analog systems, this GDT is not too devastating. GDT generally causes distortion of the signal but usually not to the point of adversely effecting the analog system.

In a digital system, however, GDT can be devastating if the delay is too great. The heart of a digital system is the square wave (pulse). The square wave is composed of many sine waves of various frequencies (harmonics). The higher and lower sine wave frequencies form the squared off shoulders and the steep transition point. The frequencies most important to a square wave's shape are the frequencies usually effected the most by the GDT effect. This effect can degrade the square wave to a point where it loses all meaning to a digital system. For a digital system engineer, this means that his Bit Error Rate (BER) will suffer.

A band pass filter's characteristics have a significant effect on the magnitude of GDT deviation that occurs between the delay times of each frequency in the pass-band. A band-pass filter with a Butterworth type response has poor GDT performance but has good selectivity and a flat pass-band. The Butterworth response is characterized by a flat pass-band

with relatively sharp roll-off (Figure 32a).

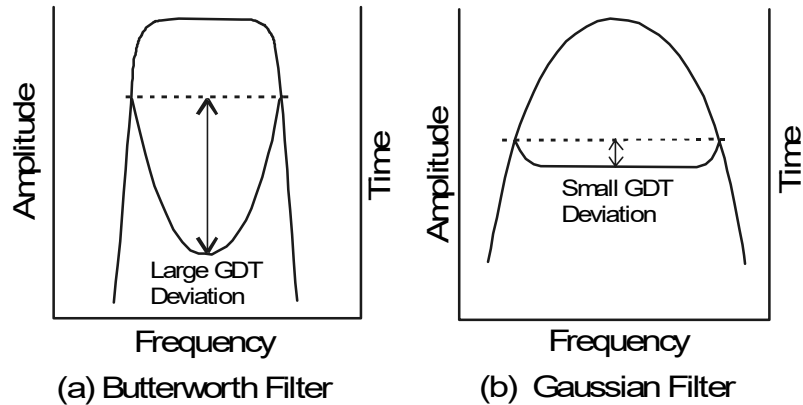

Figure 32: Types of Band Pass Filter

The GDT of this type of filter is characterized by a large deviation time between the frequencies around the center frequency and the frequencies at the pass-band edges.

A band-pass filter with a Gaussian type response has good GDT performance, but only moderate selectivity (Figure 32b). The Gaussian response is characterized by a rounded pass-band with moderate roll-off. The GDT of this type of filter is characterized by a small deviation time between the frequencies around the center frequency and the frequencies at the pass-band edges.

One important point to make is this: if all frequencies in the pass-band were delayed by the same amount of time, the overall negative effect to the system (analog or digital) is diminished.

GDT Specification

In the specification for a filter that has controlled GDT characteristics, Murata specifies GDT deviation as opposed to absolute GDT. Absolute GDT references all measurements from the time a signal is inserted into the filter. GDT deviation refers to the time difference from the first frequency out of the filter to the last frequency out of the filter, for a given signal. GDT deviation is a better measurement since the most important information is how the frequencies deviate from each other in time. In all GDT measurements, the unit of measure is time (usually in nanoseconds or microseconds) over a given bandwidth. Here is an example of a GDT spec: 25 μ S max over \pm 30kHz (referenced to f_0).

Other Band Pass Filter Characteristics

Figure 33 shows the response plot of the output from a band pass filter. The various band pass characteristics of inter-

est are labeled and numbered. The explanation for each of these characteristics is shown in the table.

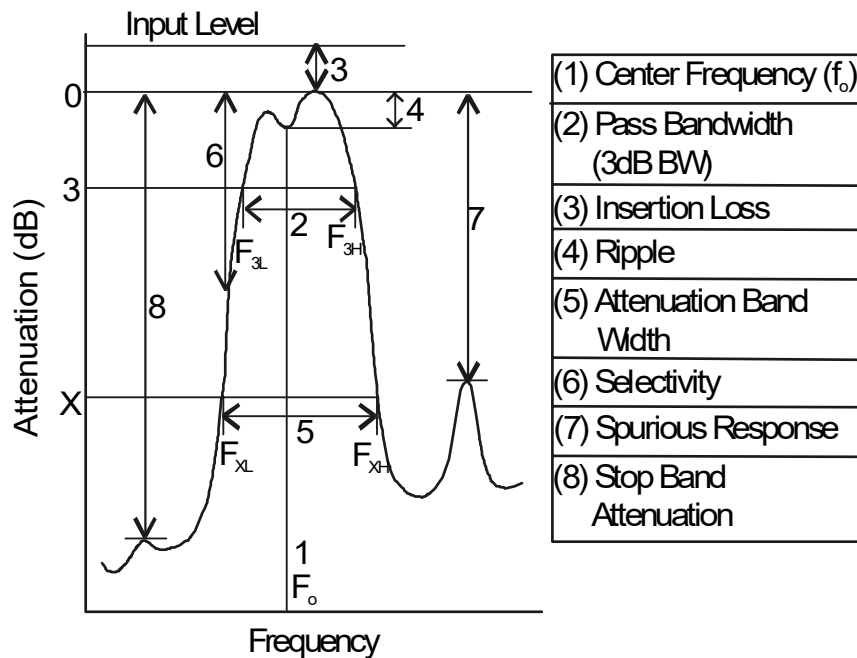

Figure 33: Band Pass Filter Characteristics

- Center Frequency

The frequency in the center of the pass band. To calculate the center frequency, use the following equation (some symbol notation is from Figure 33):

$$F_o = \frac{F_{3L} - F_{3H}}{2}$$

Example: $F_o = 455\text{kHz}$

- Pass-Bandwidth

This is the difference between the two frequencies (F_{3L} and F_{3H}) that intersect a horizontal line 3dB down from the point of minimum loss. Depending on the filter type, some filters specify the 6dB bandwidth instead of the 3dB bandwidth. In this case, the horizontal line used to intersect the frequency plot is 6dB down from the point of minimum loss. Example: 3dB B.W. = 60kHz total or $\pm 30\text{kHz}$ (referenced to f_o).

6dB B.W. = 64kHz total or $\pm 32\text{kHz}$ (referenced to f_o).

- Insertion Loss

The minimum loss for a given input signal associated with the given filter. It is expressed as the input/output ratio at the point of minimum loss. The insertion loss for some filter products is expressed as the input/output ratio at the center frequency.

Example: I.L. = 5dB max.

- Ripple

If there are peaks and valleys in the pass band, the ripple is expressed as the difference between the maximum peak and the minimum valley.

Example: Ripple = 1dB max.

- Attenuation Bandwidth

Attenuation bandwidth is the bandwidth of the pass-band at a specified level of attenuation. This is similar to the 3dB or 6dB bandwidth except that the attenuation level used is significantly higher, usually 20dB or larger. In Figure 33, it is the difference between F_{XL} and F_{XH} where "X" is the attenuation level.

Example: 40dB B.W. = 100kHz total or $\pm 50\text{kHz}$ (referenced to f_0).

- Stop Band Attenuation

Stop band attenuation is the maximum level of strength allowed for frequencies outside of the pass-band.

Example: Attenuation 455 $\pm 100\text{kHz}$ = 35dB min.

- Spurious Response

The spurious response is the difference in decibels (dB) between the insertion loss and the spurious response in the stop band (area not in the specified pass-band).

Example: Spurious Response = 25dB min.

- Input / Output Impedance

The input and output impedances are the impedance values that the filter should be electrically matched to at the filter's input and output, respectively.

Example: I/O impedance = $1\text{K}\Omega$

- Selectivity

The selectivity is the ability of a band pass filter to pass signals in a given frequency bandwidth and reject (or attenuate) all frequencies outside of the given bandwidth. A highly selective filter has an abrupt transition between the pass-band region and the stop band region. This is expressed as the shape factor, which is the attenuation bandwidth, divided by the pass bandwidth. The filter becomes more selective as the resulting value approaches one.

Connecting Filters In Series

It is sometimes helpful to increase outband attenuation by connecting filters in series. If the input and output impedances of the filters are equal, then the filters may be connected directly to each other. If they have different impedances, a matching circuit may be necessary.

The main advantage to connecting filters in series is that there is a much better spurious response attenuation and outband attenuation. Some disadvantages are that insertion loss, GDT, and ripple are all additive. The differences between worst case and best case for each specification can cause a wide variation in these specifications when they are added. For example, if the insertion loss of a filter is specified to be between 3 and 6dB, then when they are added the insertion loss will be between 6 and 12dB.

The main disadvantage is that the center frequency variations part to part can decrease the absolute bandwidth of the combination of filters. As can be seen in Figure 34, if the center frequencies are slightly off, then the absolute bandwidth will be between the lower end of the filter that is centered higher and the upper end of the filter that is centered lower.

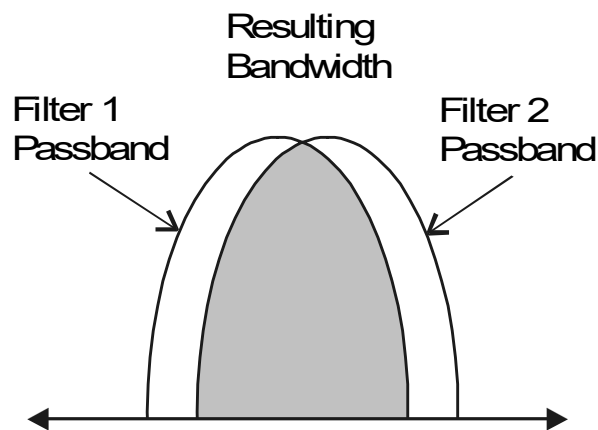

Figure 34: Resulting Bandwidth When Cascading Filters

The resulting center frequency will be somewhere between the two filters. For some applications this is not a large problem and is cheaper than buying filters with more elements.

PZT Band Pass Filters

Filter types available

The PZT group of Murata only offers band pass filters. We offer band pass filters with the following center frequencies:

- 450kHz or 455kHz
- 10.7MHz and 4.5 to 6.5MHz (Sound IF applications for video)

Note: Murata's PZT group also makes band pass filters from 3.58MHz to 6.5MHz, but these filters are typically for video / TV applications only. We can also offer VIFSAW filters, which are band pass filters too, but are also for video / TV applications specifically. There is a specific application manual for these video products, but the concepts for band pass filters apply to these products as well.

Most filters are available in both leaded and surface mount (SMD) packages. Certain specialty filters are only available in leaded packages.

The next section will display the variety of Murata filters available at 450/455kHz and 10.7MHz, and each filter's basic electrical specifications

kHz Filters

Introduction

The kHz ceramic filters were originally designed for AM radio applications that used 450kHz or 455kHz as a radio IF frequency. In the past, engineers would use tunable coils to achieve the required IF filtering for AM radios. Ceramic filters replaced this type of tuned filter, offering a tuning free product that had excellent filter characteristics at a low cost. Murata's kHz ceramic IF filters are fundamentally ladder filters. You will see later that MHz filters are not ladder filters, but rather are monolithic in construction (multiple elements on one piece of ceramic).

A ladder filter uses series and parallel resonant elements (or resonators) to achieve a particular filtering characteristic (Figure 35).

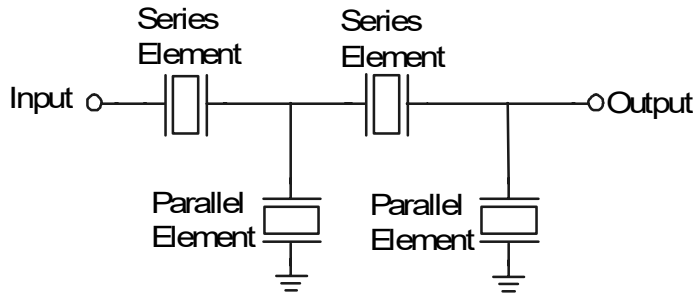

Figure 35: Connection Diagram of Resonate elements in kHz Filter

The more series and parallel elements in a ladder filter, the steeper the sides of the passband and the greater the ability of the filter to reject or attenuate the frequencies not in the pass-band of the filter.

How Does It Work

It has been mentioned that the filter uses resonators in a ladder configuration, but it can be hard to understand how a ceramic resonator may be used to construct a filter. To simplify the explanation, we will examine the operation of a two-element ladder filter (Figure 36).

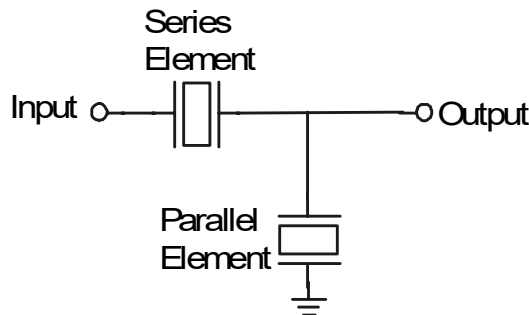

Figure 36: Two Element kHz Filter Example

To begin the discussion, one must have a basic understanding of the electrical characteristics of a resonator, specifically its impedance response. A ceramic resonator has the impedance response shown in Figure 37.

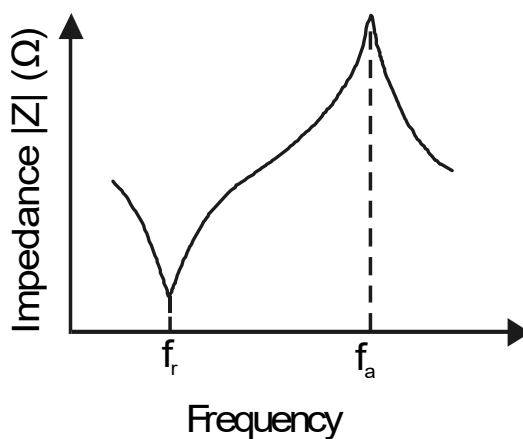

Figure 37: Impedance Plot of Ceramic Resonator

As can be seen from Figure 37, a ceramic resonator has two key impedance parameters: f_r and f_a . f_r is the frequency where the resonator's impedance is the lowest and f_a is the frequency where the resonator's impedance is the highest. For a normal resonator, the resonator will oscillate somewhere between these two frequencies, or, in other words, between the impedance minimum and maximum.

By combining two resonators in a ladder configuration where one resonator is the series element and one resonator is the parallel element of the filter, a band pass filter type of performance can be achieved. Figure 38 illustrates this.

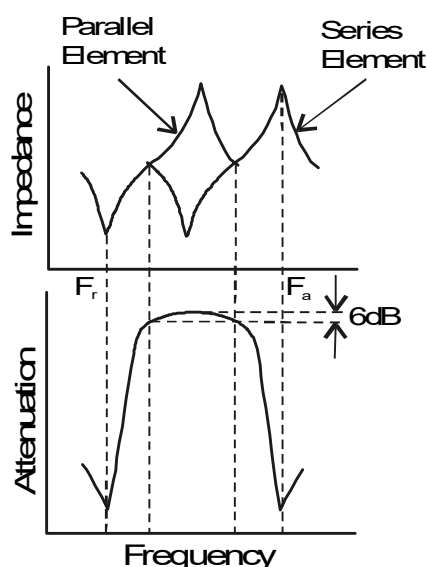

Figure 38: Resonators Combined to Achieve Bandpass Filter

As shown in Figure 38, the impedances at f_r and f_a of the parallel and series resonant elements are used to make the band pass characteristic. The impedance of the parallel element at f_r is used to make the band pass filter's attenuation point below the pass band. The impedances at f_a of the parallel element and at f_r of the series element make the band itself. Finally, the impedance at f_a of the series element is used to make the band pass filter's attenuation point above the pass band. By using these impedances, the basic band pass characteristics are achieved. By increasing the number of elements, the selectivity and stop-band attenuation are improved.

At any frequency below f_r and above f_a , resonators are electrically equivalent to capacitors. To attenuate frequencies in the stopband of the filter, the shunt capacitance of the parallel resonant elements must be much larger than that of the series resonant elements.

Parts

The following series of tables will cover the kHz filter part numbering structure, show the difference between the various kHz filter series, and provide a chart of electrical characteristics for each series

Figure 39 shows basic kHz filter part numbering structure.

Table 6 shows current available kHz filter series and describes each series generally. Some older series are shown for reference purposes, so all series with an asterisk (*) are not available for new designs and may be obsolete.

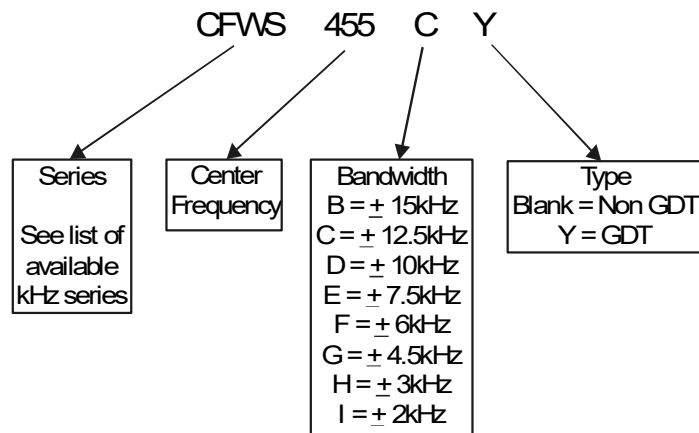

Figure 39: kHz Filter Part Numbering System

kHz Filter Series Type	Description	GDT Type	Metal or Plastic Case	SMD	Promoted In US
CFYM Series*	Miniature 2 element IF filter	N	P	N	N
CFU Series*	4 element IF filter	N	P	N	Y
CFUM Series	Miniature version of CFU series	N	P	N	Y
CFWM Series	Miniature version of CFW series	N	P	N	Y
CFWS Series	6 element IF filter. Lower profile than the CFW series Replaces CFW series filter.	N	P	N	Y
CFV Series*	7 element IF filter	N	P	N	N
CFVS Series*	7 element low profile version of the CFV series	N	P	N	N
CFVM Series*	Miniature version of the CFV series	N	P	N	Y
CFZM Series*	Miniature high performance 9 element IF filter	N	P	N	Y
CFUS...Y Series*	4 element GDT IF filter. Replaces SFG series	Y	P	N	Y
CFUM...Y Series	Miniature version of CFUS...Y series. Replaces SFGM series	Y	P	N	Y
CFWS...Y Series	6 element GDT IF filter. Replaces SFH series	Y	P	N	Y
CFWM...Y Series	Miniature version of CFWS...Y series. Replaces SFHM series	Y	P	N	Y
SFPC Series	Low cost (5mm) 4 element SMD IF filter	N	P	Y	Y
CFUCG Series	Low Profile (4mm) 4 element SMD IF filter. Typically narrower bandwidths only.	N	P	Y	Y
CFUCG...X Series	Low Profile (4mm) 4 element mid-GDT SMD IF filter. Typically narrower bandwidths only.	Y	P	Y	Y
SFGCG Series	Low Profile (4mm) 4 element GDT SMD IF filter. Typically wider bandwidths only.	Y	P	Y	Y

Table 6. kHz Filter Description (all SMD parts are on tape and part numbers end in “-TC”)

CFUCJ Series*	Low Profile (4mm) 4 element SMD IF filter. Typically narrower bandwidths only. "Y" version (GDT) possible for wider bandwidths.	Y/N	P	Y	Limited
CFUCH Series	Low Profile (3mm) 4 element SMD IF filter. Typically narrower bandwidths only. "Y" version (GDT) possible for wider bandwidths.	Y/N	P	Y	Limited
CFWC Series	Low Profile (3mm) 6 element SMD IF filter. Typically narrower bandwidths only. "Y" version (GDT) possible for wider bandwidths.	Y/N	P	Y	Limited
CFZC Series	Low Profile (3mm) 8 element SMD IF filter. Typically narrower bandwidths only. "Y" version (GDT) possible for wider bandwidths.	Y/N	P	Y	Limited
CFUXC Series	Low Profile (2mm) 4 element SMD IF filter.	Y	P	Y	Y
CFJ Series*	11 element IF filter. 455kHz version only.	N	M	N	Y
CFG Series*	A miniature 7 element filter with performance like CFM Series. 455kHz version only.	N	M	N	Y
CFX Series*	A miniature 9 element filter with performance like CFL Series. 455kHz version only.	N	M	N	Y
CFL Series*	A miniature 9 element filter with performance like CFR Series. 455kHz version only.	N	M	N	Y
CFK Series*	A miniature 11 element filter with performance like CFS series. 455kHz version only	N	M	N	Y
CFM Series*	9 element filter. 455kHz version only	N	M	N	Y
CFR Series*	11 element filter. 455kHz version only.	N	M	N	Y
CFS Series*	Highest selectivity: 15 element filter. 455kHz version only.	N	M	N	Y
CFKR Series*	Highly selective GDT 11 element filter. For narrower bandwidths. 455kHz version only.	Y	M	N	Y
CFL...G series*	Highly selective GDT 9 element filter. For wider bandwidths. 455kHz version only.	Y	M	N	Y

Table 6. kHz Filter Description (all SMD parts are on tape and part numbers end in "-TC")

Table 7 provides a more detailed performance description for the common kHz filter parts in each series.

Part Number (450kHz also available)	Nominal Center Frequency (kHz)	3dB Bandwidth (kHz) min.	6dB Bandwidth (kHz) min.	20 dB Bandwidth (kHz) max.	Attenuation 455+100kHz (dB) min.	Insertion Loss (dB)	Input/ output Impedance (Ω)	
CFYM Series*								
CFYM455B	455	-----	± 15	± 30	11	4	1,500	
CFYM455C	455	-----	± 12.5	± 24	12	4	1,500	
CFYM455D	455	-----	± 10	± 20	12	4	1,500	
CFYM455E	455	-----	± 7.5	± 15	12	4	1,500	
CFYM455F	455	-----	± 6	± 12.5	12	4	2,000	
				40 dB Bandwidth (kHz) max.				Ripple (dB) max.
CFU Series*								
CFU455B2	455±2	-----	± 15	± 30	27	4	1,500	3 (455±10)
CFU455C2	455±2	-----	± 12.5	± 24	27	4	1,500	4 (455±8)
CFU455D2	455±1.5	-----	± 10	± 20	27	4	1,500	2 (455±7)
CFU455E2	455±1.5	-----	± 7.5	± 15	27	6	1,500	1.5 (455±5)
CFU455F2	455±1.5	-----	± 6	± 12.5	27	6	2,000	1.5 (455±4)
CFU455G2	455±1	-----	± 4.5	± 10	25	6	2,000	1.5 (455±3)
CFU455H2	455±1	-----	± 3	± 9	25	6	2,000	2 (455±2)
CFU455I2	455±1	-----	± 2	± 7.5	25	6	2,000	2 (455±1.5)
CFU455HT	455±1	-----	± 3	± 9	35	6	2,000	2 (455±2)
CFU455IT	455±1	-----	± 2	± 7.5	35	6	2,000	2 (455±1.5)

Table 7. kHz Filters (455kHz shown, but 450kHz version also available for most filters)

CFUM Series									
CFUM455B	455	-----	± 15	± 30	27	4	1,500	-----	
CFUM455C	455	-----	± 12.5	± 24	27	4	1,500	-----	
CFUM455D	455	-----	± 10	± 20	27	4	1,500	2 (455 \pm 7)	
CFUM455E	455	-----	± 7.5	± 15	27	6	1,500	1.5 (455 \pm 5)	
CFUM455F	455	-----	± 6	± 12.5	27	6	2,000	1.5 (455 \pm 4)	
CFUM455G	455	-----	± 4.5	± 10	25	6	2,000	1.5 (455 \pm 3)	
CFUM455H	455	-----	± 3	± 9	35	6	2,000	1.5 (455 \pm 2)	
CFUM455I	455	-----	± 2	± 7.5	35	7	2,000	2 (455 \pm 1.5)	
CFWS Series									
CFWS455B	455	-----	± 15	± 30	35	4	1,500	3 (455 \pm 10)	
CFWS455C	455	-----	± 12.5	± 24	35	4	1,500	3 (455 \pm 8)	
CFWS455D	455	-----	± 10	± 20	35	4	1,500	3 (455 \pm 7)	
CFWS455E	455	-----	± 7.5	± 15	35	6	1,500	3 (455 \pm 5)	
CFWS455F	455	-----	± 6	± 12.5	35	6	2,000	3 (455 \pm 4)	
CFWS455G	455	-----	± 4.5	± 10	35	6	2,000	2 (455 \pm 3)	
CFWS455HT	455	-----	± 3	± 9	60	6	2,000	2 (455 \pm 2)	
CFWS455IT	455	-----	± 2	± 7.5	60	6	2,000	2 (455 \pm 1.5)	
CFWM Series									
CFWM455B	455	-----	± 15	± 30	35	4	1,500	3 (455 \pm 10)	
CFWM455C	455	-----	± 12.5	± 24	35	4	1,500	3 (455 \pm 8)	
CFWM455D	455	-----	± 10	± 20	35	4	1,500	3 (455 \pm 7)	
CFWM455E	455	-----	± 7.5	± 15	35	6	1,500	3 (455 \pm 5)	
CFWM455F	455	-----	± 6	± 12.5	35	6	2,000	3 (455 \pm 4)	
CFWM455G	455	-----	± 4.5	± 10	35	6	2,000	2 (455 \pm 3)	
CFWM455H	455	-----	± 3	± 9	55	6	2,000	2 (455 \pm 2)	
CFWM455I	455	-----	± 2	± 7.5	55	7	2,000	2 (455 \pm 1.5)	
CFV Series*									
				60 dB Bandwidth (kHz) max.					Spurious 0.1-1 MHz (dB) min.
CFV455B	455	± 10	± 15	± 25	50	4	1,000	3	25
CFV455C	455	± 9	± 13	± 23	50	4	1,000	3	25
CFV455D	455	± 7	± 10	± 20	50	4	1,500	3	25
CFV455E	455	± 5.5	± 8	± 16	50	6	1,500	3	25
CFV455E10	455	± 5	± 7	± 12.5	50	6	1,500	3	25
CFV455F	455	± 4.2	± 6	± 12	50	6	1,500	3	25
CFV455G	455	-----	± 4	± 10	50	6	1,500	3	25
CFV455H	455	-----	± 3	± 7.5	50	6	1,500	3	25
CFV455I	455	-----	± 2	± 5	50	6	2,000	3	25
CFVS Series*									
CFVS455D	455	± 7	± 10	± 20	50	4	1,500	3	25
CFVS455E	455	± 5.5	± 8	± 16	50	6	1,500	3	25
CFVS455E10	455	± 5	± 7	± 12.5	50	6	1,500	3	25
CFVS455F	455	± 4.2	± 6	± 12	50	6	1,500	3	25
CFVS455G	455	-----	± 4	± 10	50	6	1,500	3	25
CFVS455H	455	-----	± 3	± 7.5	50	6	1,500	3	25
CFVM Series*									
CFVM455B	455	± 10	± 15	± 25	50	4	1,000	3	25
CFVM455C	455	± 9	± 13	± 23	50	4	1,000	3	25
CFVM455D	455	± 7	± 10	± 20	50	4	1,500	3	25
CFVM455E	455	± 5.5	± 8	± 16	50	6	1,500	3	25

Table 7. kHz Filters (455kHz shown, but 450kHz version also available for most filters)

CFVM455E10	455	± 5	± 7	± 12.5	50	6	1,500	3	25	
CFVM455F	455	± 4.2	± 6	± 12	50	6	1,500	3	25	
CFVM455G	455	-----	± 4	± 10	50	6	1,500	3	25	
CFVM455H	455	-----	± 3	± 7.5	50	6	1,500	3	25	
CFZM Series*				70 dB Bandwidth (kHz) max.						
CFZM455B	455	± 10	± 15	± 25	70	4	1,000	3	40	
CFZM455C	455	± 9	± 13	± 23	70	4	1,000	3	40	
CFZM455D	455	± 7	± 10	± 20	70	4	1,500	3	40	
CFZM455E	455	± 5.5	± 8	± 16	70	6	1,500	3	40	
CFZM455E10	455	± 5	± 7	± 12.5	70	6	1,500	3	40	
CFZM455F	455	± 4.2	± 6	± 12	70	6	1,500	3	50	
CFZM455G	455	-----	± 4	± 10	70	6	1,500	3	50	
CFZM455H	455	-----	± 3	± 7.5	70	7	1,500	3	50	
CFUS...Y Series*				40 dB Bandwidth (kHz) max.						G.D.T. Deviation Typical (μS)
CFUS455BY	455 \pm 1.5	-----	± 15	± 35	25	5	1,500	1	-----	(15) (\pm 10kHz)
CFUS455CY	455 \pm 1.5	-----	± 12.5	± 30	25	6	1,500	1	-----	(15) (\pm 8kHz)
CFUS455DY	455 \pm 1	-----	± 10	± 25	23	7	1,500	1	-----	(20) (\pm 7kHz)
CFUS455EY	455 \pm 1	-----	± 7.5	± 20	23	8	1,500	1	-----	(20) (\pm 5kHz)
CFUS455FY	455 \pm 1	-----	± 6	± 17.5	23	9	2,000	1	-----	(20) (\pm 4kHz)
CFUS455GY	455 \pm 1	-----	± 4.5	± 15	23	10	2,000	1	-----	(20) (\pm 3kHz)
CFUM...Y Series										
CFUM455BY	455 \pm 1.5	-----	± 15	± 35	25	5	1,500	-----	-----	(15) (\pm 10kHz)
CFUM455CY	455 \pm 1.5	-----	± 12.5	± 30	25	6	1,500	-----	-----	(15) (\pm 8kHz)
CFUM455DY	455 \pm 1	-----	± 10	± 25	23	7	1,500	-----	-----	(20) (\pm 7kHz)
CFUM455EY	455 \pm 1	-----	± 7.5	± 20	23	8	1,500	-----	-----	(20) (\pm 5kHz)
CFUM455FY	455 \pm 1	-----	± 6	± 17.5	23	9	2,000	-----	-----	(20) (\pm 4kHz)
CFUM455GY	455 \pm 1	-----	± 4.5	± 15	20	10	2,000	-----	-----	(20) (\pm 3kHz)
CFWS...Y Series				50 dB Bandwidth (kHz) max.						
CFWS455BY	455 \pm 1.5	-----	± 15	± 35	35	6	1,500	-----	-----	(30) (\pm 10kHz)
CFWS455CY	455 \pm 1.5	-----	± 12.5	± 30	35	7	1,500	-----	-----	(30) (\pm 8kHz)
CFWS455DY	455 \pm 1	-----	± 10	± 25	35	8	1,500	-----	-----	(30) (\pm 7kHz)
CFWS455EY	455 \pm 1	-----	± 7.5	± 20	35	9	1,500	-----	-----	(30) (\pm 5kHz)
CFWS455FY	455 \pm 1	-----	± 6	± 17.5	35	10	2,000	-----	-----	(40) (\pm 4kHz)
CFWS455GY	455 \pm 1	-----	± 4.5	± 15	35	13	2,000	-----	-----	(40) (\pm 3kHz)
CFUXC Series										
CFUXC450A100H	450	-----	± 17.5	± 55	50	5	2,000	0.5	40	(15) (\pm 12kHz)
CFUXC450B100H	450	-----	± 15	± 50	47	6	2,000	0.5	40	(15) (\pm 10kHz)
CFUXC450C100H	450	± 9 to ± 12	-----	± 35	47	6	2,000	0.5	40	(27) (\pm 10.5kHz)
CFWM...Y Series										
CFWM455BY	455 \pm 1.5	-----	± 15	± 35	35	6	1,500	-----	-----	(30) (\pm 10kHz)
CFWM455CY	455 \pm 1.5	-----	± 12.5	± 30	35	7	1,500	-----	-----	(30) (\pm 8kHz)
CFWM455DY	455 \pm 1	-----	± 10	± 25	35	8	1,500	-----	-----	(30) (\pm 7kHz)
CFWM455EY	455 \pm 1	-----	± 7.5	± 20	35	9	1,500	-----	-----	(30) (\pm 5kHz)
CFWM455FY	455 \pm 1	-----	± 6	± 17.5	35	10	2,000	-----	-----	(40) (\pm 4kHz)
CFWM455GY	455 \pm 1	-----	± 4.5	± 15	35	13	2,000	-----	-----	(40) (\pm 3kHz)

Table 7. kHz Filters (455kHz shown, but 450kHz version also available for most filters)

SFPC Series				40 dB Bandwidth (kHz) max.						
SFPC455D	455±1.5	-----	± 10	± 20	27	4	1,500	2	-----	-----
SFPC455E	455±1.5	-----	± 7.5	± 15	27	6	1,500	1.5	-----	-----
SFPC455F	455±1.5	-----	± 6	± 12.5	27	6	1,500	1.5	-----	-----
SFPC455G	455±1	-----	± 4.5	± 10	25	6	1,500	1.5	-----	-----
SFPC455H	455±1	-----	± 3	± 9	25	6	2,000	1.5	-----	-----
CFUCG Series										
CFUCG455D	455±1.5	-----	± 10	± 20	27	4	1,500	2	-----	-----
CFUCG455E	455±1.5	-----	± 7.5	± 15	27	6	1,500	1.5	-----	-----
CFUCG455F	455±1.5	-----	± 6	± 12.5	27	6	1,500	1.5	-----	-----
CFUCG455G	455±1	-----	± 4.5	± 10	25	6	1,500	1.5	-----	-----
CFUCG...X Series										G.D.T. Deviation (µS) max.
CFUCG455EX	455±1.5	-----	± 7.5	± 17.5	27	6	1,500	1	-----	25
CFUCG455FX	455±1.5	-----	± 6	± 15	27	6	1,500	1	-----	25
CFUCG455GX	455±1	-----	± 4.5	± 12.5	25	6	1,500	1	-----	25
CFUCG455HX	455±1	-----	± 3	± 10	25	7	1,500	1	-----	25
SFGCG Series										
SFGCG455AX	455±2	-----	± 17.5	± 40	25	4	1,000	1	-----	15
SFGCG455BX	455±1.5	-----	± 15	± 35	25	5	1,000	1	-----	15
SFGCG455CX	455±1.5	-----	± 12.5	± 30	25	6	1,000	1	-----	15
SFGCG455DX	455±1	-----	± 10	± 25	23	7	1,500	1	-----	20
SFGCG455EX	455±1	-----	± 7.5	± 20	23	8	1,500	1	-----	20
CFWC Series				50 dB Bandwidth (kHz) max.						
CFWC455C	455	-----	± 12.5	± 24	45	4	1,500	3 (455±8)	-----	-----
CFWC455D	455	-----	± 10	± 20	50	4	1,500	3 (455±7)	-----	-----
CFWC455E	455	-----	± 7.5	± 15	50	6	1,500	3 (455±5)	-----	-----
CFWC455F	455	-----	± 6	± 12.5	50	6	1,500	3 (455±4)	-----	-----
CFWC455G	455	-----	± 4.5	± 11	50	6	1,500	2 (455±3)	-----	-----
CFJ Series*				60 dB Bandwidth (kHz) max.						
CFJ455	455	-----	2.4 (Total)	4.5 (Total)	-----	6	2,000	2	60 (40 at 600 - 700 kHz)	-----
CFJ455	455	-----	±1.1 - ±1.3	4.5 (Total)	-----	7	2,000	2	60 (40 at 600 - 700 kHz)	-----
CFJ455	455	-----	1.0 (Total)	3.0 (Total)	60	8	2,000	1.5	-----	-----
CFG Series*										
CFG455B	455	± 10	± 15	± 25	50	4	1,000	3	25	-----
CFG455C	455	± 9	± 13	± 23	50	4	1,000	3	25	-----
CFG455D	455	± 7	± 10	± 20	50	4	1,000	3	25	-----
CFG455E	455	± 5.5	± 8	± 16	50	6	1,500	3	25	-----
CFG455E10	455	± 5	± 7	± 12.5	50	6	1,500	3	25	-----
CFG455F	455	± 4.2	± 6	± 12	50	6	1,500	3	25	-----
CFG455G	455	-----	± 4	± 10	50	6	1,500	3	25	-----
CFG455H	455	-----	± 3	± 7.5	50	6	1,500	3	25	-----
CFG455I	455	-----	± 2	± 5	50	6	2,000	3	25	-----
CFG455J	455	-----	± 1.5	± 4.5	50	8	2,000	3	25	-----
CFX Series*										

Table 7. kHz Filters (455kHz shown, but 450kHz version also available for most filters)

CFX455B	455	± 10	± 15	± 25	70	4	1,000	3	40	-----
CFX455C	455	± 9	± 13	± 23	70	4	1,000	3	40	-----
CFX455D	455	± 7	± 10	± 20	70	4	1,500	3	40	-----
CFX455E	455	± 5.5	± 8	± 16	70	6	1,500	3	40	-----
CFX455E10	455	± 5	± 7	± 12.5	70	6	1,500	3	40	-----
CFX455F	455	± 4.2	± 6	± 12	70	6	1,500	3	50	-----
CFX455G	455	-----	± 4	± 10	70	6	1,500	3	50	-----
CFX455H	455	-----	± 3	± 7.5	70	7	1,500	3	50	-----
CFX455I	455	-----	± 2	± 5	70	8	2,000	3	50	-----
CFX455J	455	-----	± 1.5	± 4.5	70	8	2,000	3	50	-----
CFL Series*										
CFL455B	455	± 10	± 15	± 25	60	4	1,000	3	40	-----
CFL455C	455	± 9	± 13	± 23	60	4	1,000	3	40	-----
CFL455D	455	± 7	± 10	± 20	60	4	1,500	3	40	-----
CFL455E	455	± 5.5	± 8	± 16	60	6	1,500	3	40	-----
CFL455E10	455	± 5	± 7	± 12.5	60	6	1,500	3	40	-----
CFL455F	455	± 4.2	± 6	± 12	60	6	1,500	3	40	-----
CFL455G	455	-----	± 4	± 10	60	6	1,500	3	40	-----
CFL455H	455	-----	± 3	± 7.5	60	7	1,500	3	40	-----
CFL455I	455	-----	± 2	± 5	60	8	2,000	3	40	-----
CFK Series*										
CFK455B	455	± 10	± 15	± 25	80	4	1,000	3	50	-----
CFK455C	455	± 9	± 13	± 23	80	4	1,000	3	50	-----
CFK455D	455	± 7	± 10	± 20	80	4	1,500	3	50	-----
CFK455E	455	± 5.5	± 8	± 16	80	6	1,500	3	50	-----
CFK455E10	455	± 5	± 7.5	± 12.5	80	6	1,500	3	50	-----
CFK455F	455	± 4.2	± 6	± 12	80	6	2,000	3	50	-----
CFK455G	455	-----	± 4	± 10	80	6	2,000	3	50	-----
CFK455H	455	-----	± 3	± 7.5	80	7	2,000	3	50	-----
CFK455I	455	-----	± 2	± 5	70	8	2,000	3	50	-----
CFK455J	455	-----	± 1.5	± 4.5	70	8	2,000	3	50	-----
CFM Series*										
CFM455A	455	± 13	± 17.5	± 30	50	3	1,000	3	30	-----
CFM455B	455	± 10	± 15	± 25	50	3	1,000	3	30	-----
CFM455C	455	± 9	± 13	± 23	50	3	1,000	3	30	-----
CFM455D	455	± 7	± 10	± 20	50	3	1,500	3	30	-----
CFM455E	455	± 5.5	± 8	± 16	45	5	1,500	3	30	-----
CFM455F	455	± 4.2	± 6	± 12	45	6	2,000	3	30	-----
CFM455G	455	-----	± 4	± 10	45	6	2,000	3	30	-----
CFM455H	455	-----	± 3	± 7.5	45	6	2,000	3	30	-----
CFM455I	455	-----	± 2	± 5	45	7	2,000	3	30	-----
CFR Series*										
CFR455A	455	± 13	± 17.5	± 30	60	4	1,000	3	40	-----
CFR455B	455	± 10	± 15	± 25	60	4	1,000	3	40	-----
CFR455C	455	± 9	± 13	± 23	60	4	1,000	3	40	-----
CFR455D	455	± 7	± 10	± 20	60	4	1,500	3	40	-----
CFR455E	455	± 5.5	± 8	± 16	55	6	1,500	3	40	-----
CFR455F	455	± 4.2	± 6	± 12	55	6	2,000	3	40	-----
CFR455G	455	-----	± 4	± 10	55	6	2,000	3	40	-----
CFR455H	455	-----	± 3	± 7.5	55	7	2,000	3	40	-----
CFR455I	455	-----	± 2	± 5	55	8	2,000	3	40	-----
CFR455J	455	-----	± 1.5	± 4.5	55	8	2,000	3	40	-----
CFS Series*										
CFS455	455	± 13	± 17.5	± 30	70	4	1,500	3	50	-----

Table 7. kHz Filters (455kHz shown, but 450kHz version also available for most filters)

CFS455	455	± 10	± 15	± 25	70	4	1,500	3	50	-----
CFS455	455	± 9	± 13	± 23	70	4	1,500	3	50	-----
CFS455	455	± 7	± 10	± 20	70	4	1,500	3	50	-----
CFS455	455	± 5.5	± 8	± 16	70	6	1,500	3	50	-----
CFS455	455	± 5	± 7	± 12.5	70	6	1,500	3	50	-----
CFS455	455	± 4.2	± 6	± 12	70	6	2,000	3	50	-----
CFS455	455	-----	± 4	± 10	70	6	2,000	3	50	-----
CFS455	455	-----	± 3	± 7.5	70	7	2,000	3	50	-----
CFS455	455	-----	± 2	± 5	70	8	2,000	3	50	-----
CFS455	455	-----	± 1.5	± 4.5	60	8	2,000	3	50	-----
CFKR Series*				Stop Bandwidth (kHz) max.						
CFRK455E1	455	± 5.8	-----	± 17 (70dB BW)	70	4	1,500	-----	-----	40 (± 6kHz)
CFRK455G1	455	± 3	± 4	± 11.5 (60dB BW)	70	6	1,500	-----	-----	35 (± 4kHz)
CFRK455H3	455	-----	± 3.5	± 11.2 (60dB BW)	60	6	1,500	-----	-----	25 (± 3.5kHz)
CFL...G Series*				60 dB Bandwidth (kHz) max.						
CFL455AG2	455± 1.0	-----	± 17.5 - ±19.5	48dBmin. (± 29kHz)	65 (± 40kHz)	7.5	1,000	-----	40	40 (± 15kHz)
CFL455BG2	455 Nominal	± 10.5	± 13.5	± 27.5	60	10	1,000	-----	30	25 (± 10.5kHz)
CFL455CG1	455 Nominal	± 9.5	± 12	± 25.5	60	10	1,000	-----	30	35 (± 9.5kHz)
CFL455DG2	455 Nominal	± 7	± 9	± 21	60	11	1,000	-----	30	35 (± 7kHz)
CFL455EG1	455 Nominal	± 5	± 7	± 18	60	13	1,500	-----	30	30 (± 5kHz)

Table 7. kHz Filters (455kHz shown, but 450kHz version also available for most filters)

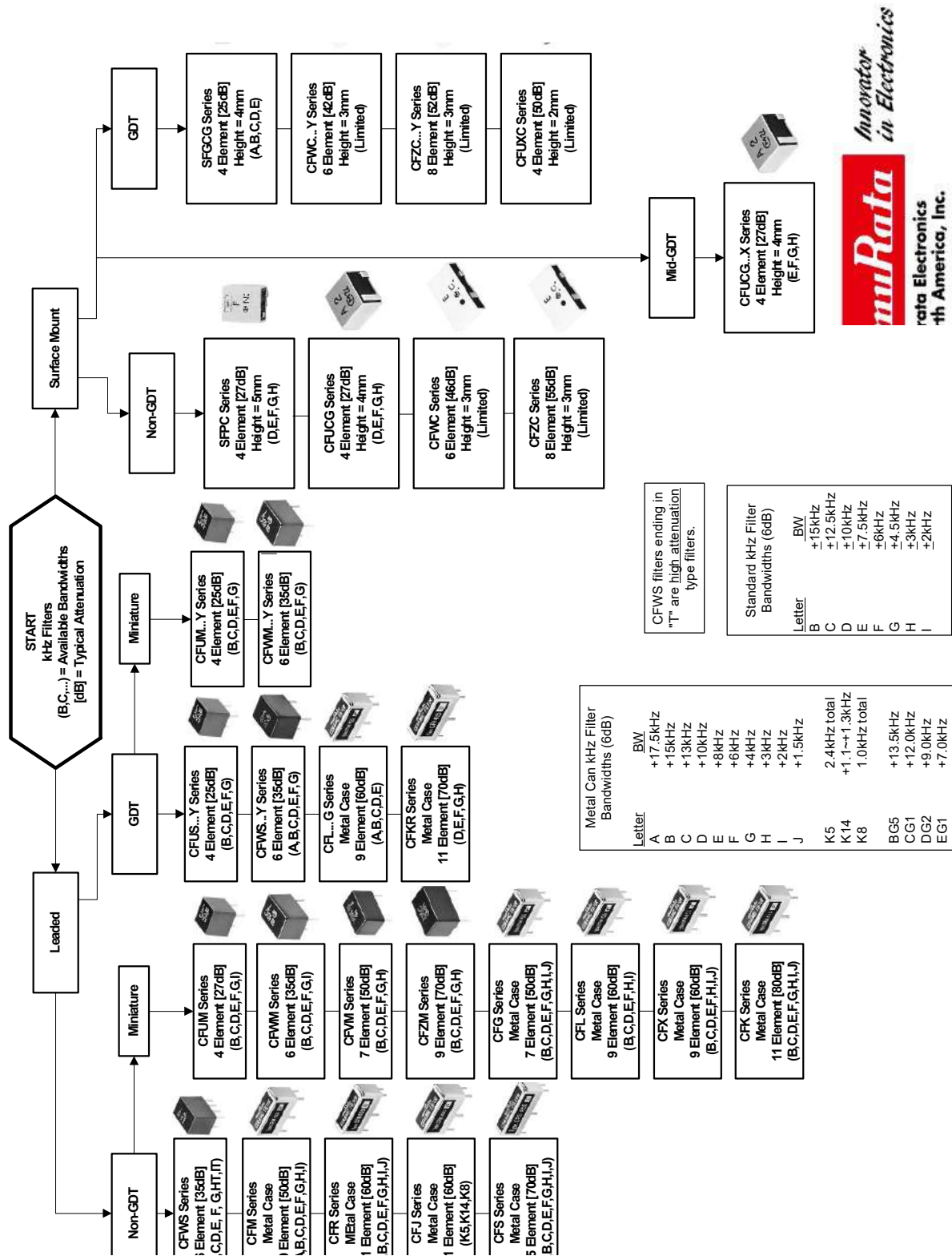

Figure 40: kHz Filter Selection Chart

MHz Filters

Introduction

Today, most FM radio designs use 10.7MHz IF filters. The characteristics of these filters help determine the performance characteristics of the radio it is used in. Besides providing low cost filtering, ceramic 10.7MHz IF filters provide high selectivity, excellent temperature and environmental characteristics, optimal GDT performance, and a pass-band that is symmetrical around the center frequency. Such filters can provide all this while being packaged in a very compact leaded or SMD package.

Murata also makes MHz filters for TV sound IF filtering. These filters operate similar to 10.7MHz filters, but cover the 3.58 to 7.0MHz range. This range covers the common Sound IF frequencies for NTSC and PAL based systems.

How Does It Work

Ceramic 10.7 MHz IF filters do not use a ladder construction like the kHz filters. The MHz filters are monolithic (one or more elements on a single substrate) in construction, similar to ceramic resonators.

These filters utilize the trapped energy of the thickness longitudinal vibration mode in a single ceramic substrate to achieve the filtering effect, unlike the kHz filters that require a number of elements to achieve the filtering effect.

You may ask why Murata does not make the kHz filter like the MHz filter or the MHz like the kHz. The answer to this is that the frequency of operation determines which vibration mode may be used to achieve the filtering effect. The area vibration mode used by the kHz filters does not work in the MHz range and the thickness longitudinal vibration mode used by the MHz filters does not work in the kHz range.

The thickness longitudinal vibration mode is used in ceramic resonators as well as MHz filters. We will start the explanation of how these filters work by explaining how a resonator works and then progress to the more complex design of the filter.

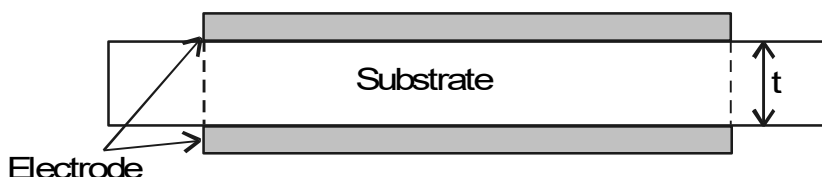

Figure 41: Basic Construction of Thickness Vibration Mode Resonator

Figure 41 shows the basic construction of a thickness expansion vibration mode resonator. A thin ceramic substrate has metal electrodes on both the top and bottom, directly over each other. Vibration of the resonator occurs only in the ceramic between the electrodes. The thickness of the ceramic substrate, shown as t in Figure 41, determines the resonant frequency of the resonator. While this design results in a very good ceramic resonator, other modifications must be made in order to make it a good filter.

Here, we come upon the idea of multi-coupling mode. In multi-coupling mode, the top electrode is divided into two separate electrodes. This new electrode allows different frequency resonances to become trapped between the electrodes (two vibration modes instead of one). The phase relationship between these two vibration modes is different as well.

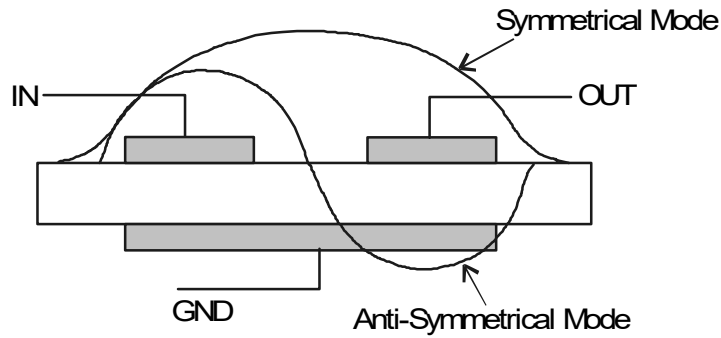

Figure 42: MHz Filter Vibration Mode

Figure 42 shows the two vibration modes resulting from the splitting of the electrode, the symmetrical and anti-symmetrical vibration modes. Since there are now two vibration modes, it is the same as having two elements in the filter.

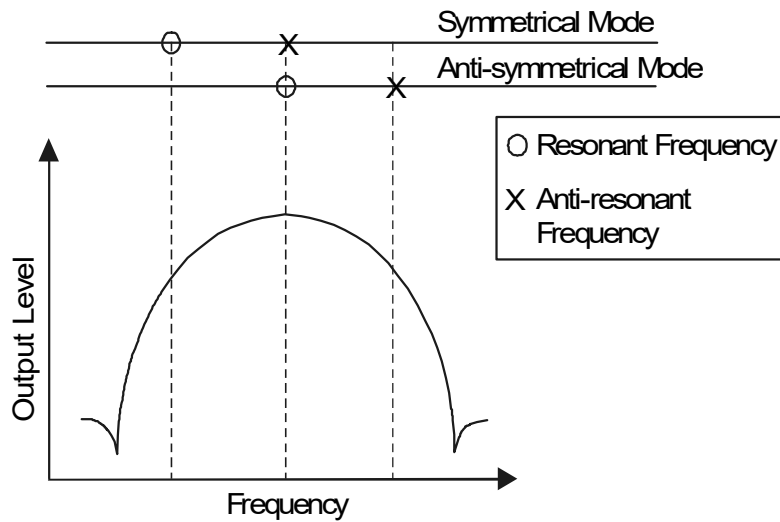

Figure 43: How the Filter Achieves Bandpass Filter Effect

Figure 43 shows how the symmetrical and anti-symmetrical modes are utilized to create the filter response. Each mode has its own resonant and anti-resonant frequency, like two separate elements. By cascading two of these split electrode patterns we produce Murata's SFE10.7 filters. Murata's SFT10.7 filters use three of these split electrode patterns on a single substrate to make an even higher selectivity filter.

Parts

The following tables show the MHz part numbering system and the filters offered by Murata. Figure 44 below describes the basic 10.7 MHz part number structure.

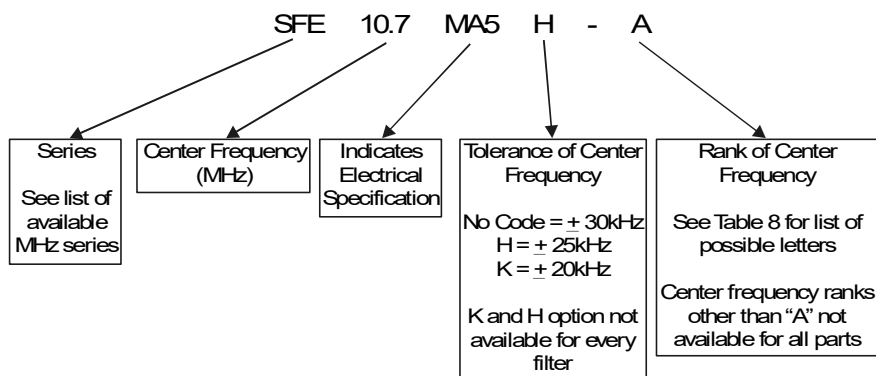

Figure 44: MHz Part Numbering System

Table 8 indicates the possible center frequency rank for the 10.7MHz filters. While all ranks are possible, all ranks have not been design up each 10.7MHz part number. Please consult with Murata for rank availability for specific 10.7MHz part number.

Code	30kHz Step Tolerance Code Equal To "No Code"	25 kHz Step Tolerance Code Equal To "H"	Color Code
D	10.64MHz±30kHz	10.64MHz±25kHz	Black
B	10.67MHz±30kHz	10.67MHz±25kHz	Blue
A	10.70MHz±30kHz	10.70MHz±25kHz	Red
C	10.73MHz±30kHz	10.73MHz±25kHz	Orange
E	10.76MHz±30kHz	10.76MHz±25kHz	White
Z	Combination Of: A,B,C,D,E		
M	Combination Of: A,B,C		

Table 8. Rank of Center Frequency

Table 9 describes each commonly available 10.7MHz and Sound IF (SFSH) filter series. Some older series are listed for reference only so any part with an asterisk (*) by it is no longer available for new designs.

MHz Filter Series Type	Description	GDT Type	SMD
SFE A10	Low loss and high selectivity	N	N
SFE B10	High attenuation	N	N
SFE C10	Thin and low profile. Same performance.	N	N
SFE MX	Controlled G.D.T filter	Y	N
SFE MA8	Controlled G.D.T filter	Y	N
SFE ML	Controlled G.D.T filter	Y	N
SFE MA19	Wide bandwidth filter.	N	N
SFE MTE	Narrow bandwidth	N	N
SFE MVE	Narrow bandwidth	N	N
SFE MFP	Narrow bandwidth	N	N

Table 9. MHz Filter Series Description

SFT	Single substrate 3 section filter. High selectivity and spurious suppression.	N	N
SFECV	Surface mount IF filter	N	Y
SFECS	Miniature version of SFECV	N	Y
CFEC*	Surface mount IF filter	N	Y
KMFC545	Super wide bandwidth filter	N	N
CFECV	GDT controlled version of SFECV	Y	Y
CFECS	Miniature version of CFECV	Y	Y
SFSH*	TV IF filter, 3.58 – 6.5MHz	N	N
SFSRA	TV IF filter, 3.58 – 6.5MHz	N	N
SFSCC	Surface Mount TV IF filter, 3.58 – 6.5MHz	N	Y

Table 9. MHz Filter Series Description

Table 10 provides general electrical specification for common 10.7MHz and Sound IF (SFSH) filters. *Please note that values in parentheses are typical values.*

Part Number	Nominal Center Frequency (MHz)	3dB Bandwidth (kHz) min.	20 dB Bandwidth (kHz) max.	Insertion Loss (dB)	Input/output Impedance	Ripple (dB) max.	Spurious (9-12MHz) (dB) min.	G.D.T. Bandwidth (kHz) min.
SFE Series								
SFE10.7MA5-A	10.7	280±50	650 (520)	6 (4)	330	1	30 (43)	-----
SFE10.7MS2-A	10.7	230±50	570 (420)	6 (4)	330	1	40 (45)	-----
SFE10.7MS3-A	10.7	180±40	520 (380)	7 (4.5)	330	1	40 (45)	-----
SFE10.7MA5A10-A	10.7	280±50	590 (480)	2.5 ± 2.0	330	1	30 (42)	-----
SFE10.7MS2A10-A	10.7	230±40	520 (410)	3.0 ± 2.0	330	1	35 (42)	-----
SFE10.7MS3A10-A	10.7	180±40	470 (370)	3.5 ± 1.5	330	1	35 (42)	-----
SFE10.7MJA10-A	10.7	150±40	360 (300)	4.5 ± 2.0	330	1	35 (42)	-----
SFE10.7MA5B10-A	10.7	280±50	650	3.0 ± 2.0	330	1	45	-----
SFE10.7MS2B10-A	10.7	230±50	570	3.0 ± 2.0	330	1	45	-----
SFE10.7MS3B10-A	10.7	180±40	520	5.0 ± 2.0	330	1	45	-----
SFE10.7MA5C10-A	10.7	280±50	650 (540)	3.0 ± 2.0	330	1	30 (47)	-----
SFE10.7MS2C10-A	10.7	230±50	570 (470)	3.0 ± 2.0	330	1	40 (49)	-----
SFE10.7MS3C10-A	10.7	180±40	470 (360)	3.5 ± 2.0	330	1	35 (47)	-----
SFE10.7MJC10-A	10.7	150±40	360 (300)	4.5 ± 2.0	330	1	35 (42)	-----
SFE10.7MHC10-A	10.7	110±30	350 (260)	7.0 ± 2.0	330	1	30 (38)	-----
SFE10.7MX-A	10.7	250±40	670 (620)	12 (10)	330	0 max.	25 (33)	0.2µS f _o ± 110kHz
SFE10.7MX2-A	10.7	220±40	610 (560)	12.5 (10.5)	330	0 max.	30 (37)	0.15µS f _o ± 80kHz
SFE10.7MZ1-A	10.7	180±30	530 (460)	14 (12.3)	330	0 max.	33 (38)	0.15µS f _o ± 60kHz
SFE10.7MZ2-A	10.7	150±30	500 (420)	14 (12.6)	330	0 max.	35 (41)	015µS f _o ± 50kHz
SFE10.7MA8-A	10.7	280±50	650 (520)	6 (4)	330	0.5 max.	30 (43)	0.5µS f _o ± 80 (100)
SFE10.7MS2G-A	10.7	230±50	600 (420)	7 (4.5)	330	0 max.	40 (45)	0.5µS f _o ± 60 (75)
SFE10.7MS3G-A	10.7	180±40	520 (380)	7 (5)	330	0 max.	40 (45)	0.5µS f _o ± 45 (60)
SFE10.7ML-A	10.7	280±50	700 (610)	9 (7)	330	0 max.	25 (33)	0.25µS f _o ± 70 (105)
SFE10.7MP3-A	10.7	250±50	650 (550)	10 (8)	330	1.0 max.	30 (35)	0.25µS f _o ± 65 (90)
SFE10.7MM-A	10.7	230±50	600 (510)	11 (9)	330	0 max.	30 (38)	0.25µS f _o ± 60 (85)
SFE10.7MA19	10.7	350 (450)	950 (750)	3 ± 2	330	3	20 (30)	-----
SFE10.7MA20-A	10.7	330 ± 50	680 (615)	4 ± 2	330	1	30 (40)	-----
SFE10.7MA21	10.7	400 (500)	950 (750)	3 ± 2	330	3	20 (30)	-----
SFE10.7MHY-A	10.7	110±30	350 (260)	7 ± 2	330	1	30 (38)	-----
SFE10.7MTE	10.7	±25 (80)	200 (160)	6.5 ± 2.5	330	1	30 (55)	-----
SFE10.7MVE	10.7	±13 (53)	135 (109)	6.0 ± 2.0	330	1	30 (50)	-----
SFE10.7MFP	10.7	±20 (38)	95 (78)	6.0 (3.4)	330	1	24 (28)	-----
SFE10.7MFP1	10.7	Fn±5min. Fn ±35 max.	-----	6	600	-----	-----	-----

Table 10. MHz Filters

SFT Series			40 dB Bandwidth (kHz) max.			Ripple within 3dB BW (dB)		
SFT10.7MA5	10.7	280 ± 50	700 (630)	6 ± 2	330	0.5 max.	50 (60)	-----
SFT10.7MS2	10.7	230 ± 40	650 (580)	6 ± 2	330	0.5 max.	50 (60)	-----
SFT10.7MS3	10.7	180 ± 40	550 (500)	8 ± 2	330	0.5 max.	50 (60)	-----
SFECV Series								
SFECV10.7MA21S-A-TC	10.7	400 ± 50	-----	3.0 ± 2	470	3.0 max.	20	-----
SFECV10.7MA19S-A-TC	10.7	350 ± 50	-----	3.0 ± 2.0	470	3.0 max.	20	-----
SFECV10.7MA2S-A-TC	10.7	330 ± 50	-----	4 ± 2	330	-----	30	-----
SFECV10.7MA5S-A-TC	10.7	280±50	-----	6	330	-----	30	-----
SFECV10.7MS2S-A-TC	10.7	230±50	-----	6	330	-----	30	-----
SFECV10.7MS3S-A-TC	10.7	180±40	-----	7	330	-----	30	-----
SFECV10.7MHS-A-TC	10.7	150±40	-----	5.5 ± 2.0	330	-----	30	-----
SFECV10.7MJS-A-TC	10.7	110±30	-----	6.0 ± 2.0	330	-----	35	-----
SFECS Series								
SFECS10.7MA5-A-TC	10.7	280±50	590	3.0 ± 2	330	1.0 max.	30	-----
SFECS10.7MS2-A-TC	10.7	230±50	510	3.5 ± 2	330	1.0 max.	30	-----
SFECS10.7MS3-A-TC	10.7	180±40	470	4.5 ± 2	330	1.0 max.	30	-----
CFEC Series*								G.D.T. Deviation (µS) max.
CFEC10.8MK1-TC	10.8	±110 to ±115	±310	6	330	(fn ± 100kHz) 0.5	-----	(fn ± 100kHz) 1.5
CFEC10.8MG1-TC	10.8	±135 to ±180	±350	6	330	(fn ± 100kHz) 0.5	-----	(fn ± 100kHz) 1.2
CFEC10.8ME11-TC	10.8	±150	±420	5	330	(fn ± 110kHz) 1	25	(fn ± 110kHz) 1.5
CFEC10.8MD11-TC	10.8	±170	±450	5	600	(fn ± 170kHz) 1	25	(fn ± 170kHz) 2.0
CFECS Series								
CFECS10.75ME11	10.75	±110	±310	6	330	0.5	-----	1.5
CFECS10.75MK1	10.75	±150	±420	5	330	1	25	1.5
CFECS14.6ME21	14.6	±150	±500	6	330	1	-----	0.8
CFECS14.6ME27	14.6	±90	-----	6	330	2	-----	1
CFECV Series								

Table 10. MHz Filters

CFEVCV13.0ME21	13.0	± 90	-----	6	330	1	-----	1.5
CFEVCV14.6ME21	14.6	± 150	± 500	6	330	1	-----	0.8
SFSH Series								
SFSH4.5MCB	4.5	± 60 (110)	600 (470)	6 (3.2)	1000	-----	30 (0 - 4.5MHz)	-----
SFSH5.5MCB	5.5	± 60 (115)	600 (500)	6 (3.6)	600	-----	30 (0 - 5.5MHz)	-----
SFSH6.0MCB	6	± 60 (115)	600 (500)	6 (4.0)	470	-----	30 (0 - 6.0MHz)	-----
SFSH6.5MCB	6.5	± 70 (115)	650 (530)	6 (3.6)	470	-----	30 (0 - 6.5MHz)	-----
SFSH4.5MDB	4.5	± 70 (130)	750 (520)	6 (3.0)	1000	-----	30 (0 - 4.5MHz)	-----
SFSH5.5MDB	5.5	± 80 (150)	750 (640)	6 (3.0)	600	-----	30 (0 - 5.5MHz)	-----
SFSH6.0MDB	6	± 80 (155)	750 (640)	6 (3.8)	470	-----	30 (0 - 6.0MHz)	-----
SFSH6.5MDB	6.5	± 80 (150)	800 (640)	6 (3.4)	470	-----	30 (0 - 6.5MHz)	-----
SFSH4.5MEB2	4.5	± 125 (180)	800 (740)	6 (3.0)	1000	-----	25 (0 - 4.5MHz)	-----
SFSRA Series								
SFSRA4M50EF00-B0	4.5	± 125	850	6.0 max.	1000	-----	25 (0 - 4.5MHz)	-----
SFSRA4M50DF00-B0	4.5	± 70	750	6.0 max.	1000	-----	30 (0 - 4.5MHz)	-----
SFSRA5M50DF00-B0	5.5	± 80	750	6.0 max.	600	-----	30 (0 - 5.5MHz)	-----
SFSRA6M00DF00-B0	6.0	± 80	750	6.0 max.	470	-----	30 (0 - 6.0MHz)	-----
SFSRA6M50DF00-B0	6.5	± 80	800	6.0 max.	470	-----	30 (0 - 6.5MHz)	-----
SFSRA4M50CF00-B0	4.5	± 60	600	6.0 max.	1000	-----	30 (0 - 4.5MHz)	-----
SFSRA5M50EF00-B0	5.5	± 60	600	6.0 max.	600	-----	30 (0 - 5.5MHz)	-----
SFSRA6M00CF00-B0	6.0	± 60	600	6.0 max.	470	-----	30 (0 - 6.0MHz)	-----
SFSRA6M50CF00-B0	6.5	± 80	650	6.0 max.	470	-----	30 (0 - 6.5MHz)	-----
SFSRA5M50BF00-B0	5.5	± 50	400	8.0 max.	600	-----	30 (0 - 5.5MHz)	-----
SFSRA5M74BF00-B0	5.742	± 50	400	8.0 max.	600	-----	30 (0 - 5.742MHz)	-----
KMFC Series								
KMFC545	10.7	± 325	1400	5	470	2.0	23 (8 - 13MHz)	-----

Table 10. MHz Filters

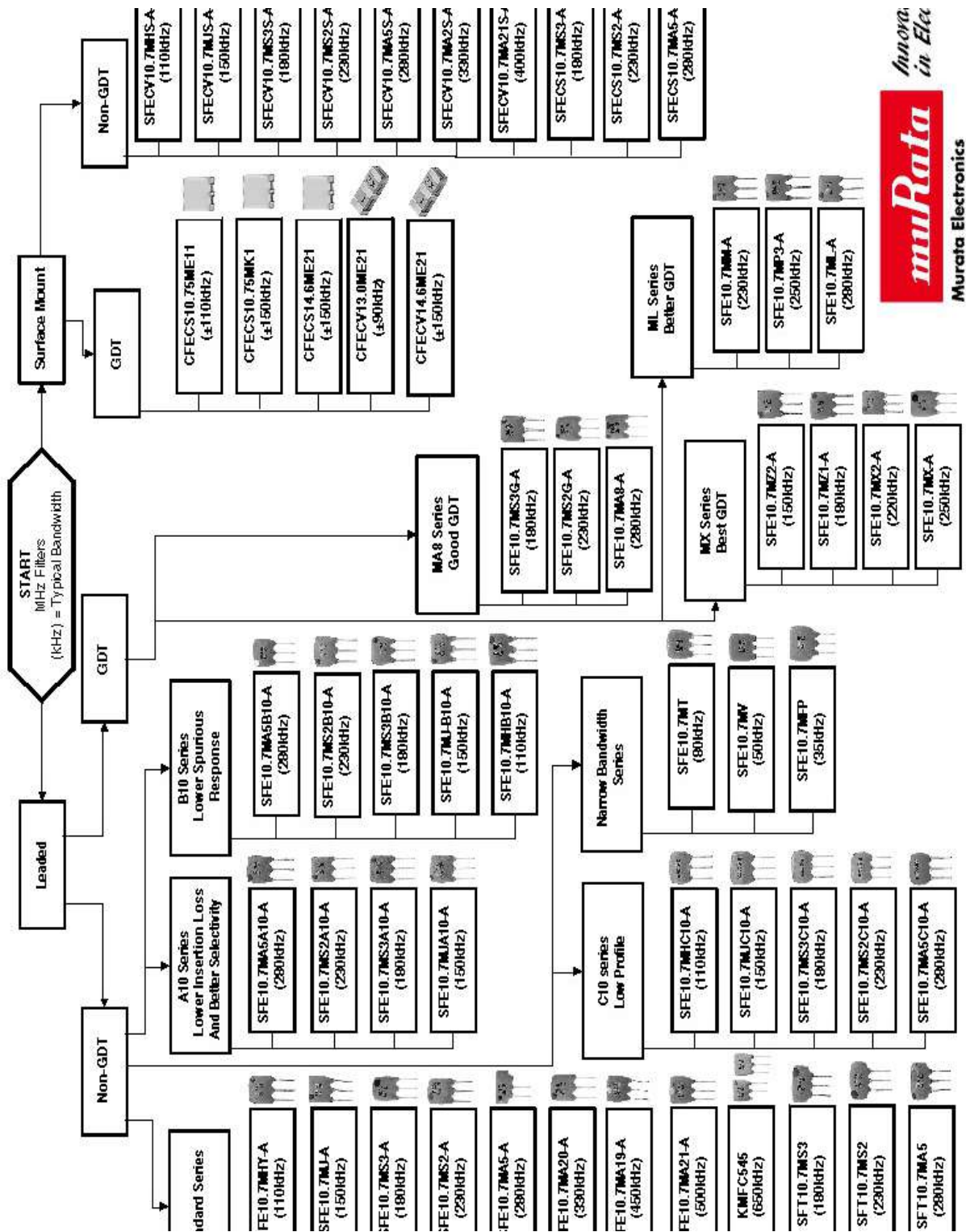

Figure 45: MHz Filter Selection Chart

Applications

One of the primary uses of band pass filters is in receivers. The simplest receiver is called a super heterodyne receiver (Figure 46). This receiver uses two band pass filters to select the desired signal. The first filter is a wide bandwidth filter that helps reduce noise and extraneous signals. The local oscillator then mixes down the signals and the second band pass filter selects the correct IF frequency. In the USA, the IF for AM radio is 455kHz and the IF for FM radio is 10.7MHz. The signal then goes to an amplifier and then to a discriminator that strips away the carrier signal.

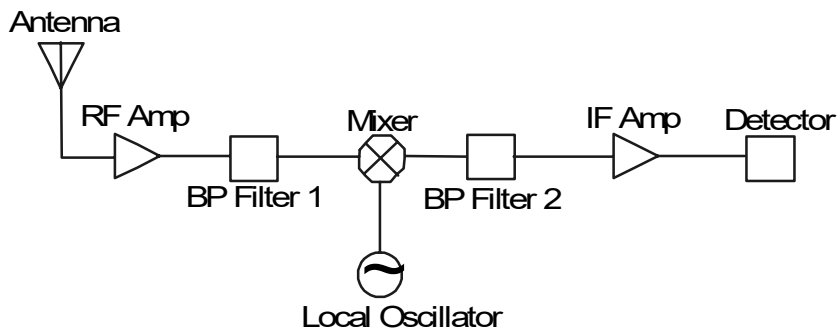

Figure 46: Super Heterodyne Receiver

The second type of receiver is the double super heterodyne receiver (Figure 47). This receiver uses three band pass filters and two local oscillators. The first filter helps reduce noise just as before. The first local oscillator mixes the signal down to the first IF. The second filter selects only this IF frequency to pass on to the rest of the circuit. The second oscillator mixes the signal down to the second IF which is 455kHz or 10.7MHz as before. The third filter selects only these second IF frequencies to pass to the detector. This receiver has better selectivity due to the increased filtering and the smaller jump when the frequencies are mixed down.

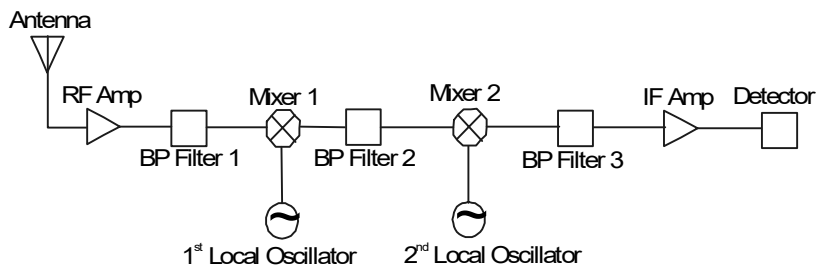

Figure 47: Double Super Heterodyne Receiver

TV Filter Application

Murata's SFSH series was originally designed for TV applications but has found wide use in the communications industry. These filters are designed to filter out the sound IF of a TV signal. A television signal has three parts: a sound sig-

nal, a picture signal, and a color or chroma signal (Figure 48).

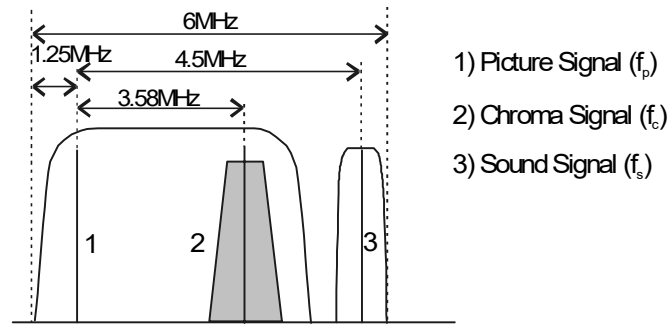

Figure 48: TV Channel Spectrum Description (NTSC-M)

A basic television receiver is shown in Figure 49.

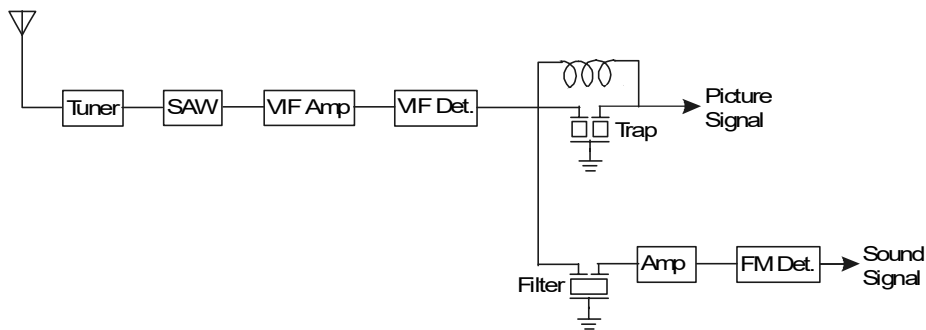

Figure 49: Inter-Carrier System

First a tuner shifts the desired channel to IF frequencies. A SAW filter selects only the IF frequencies and rejects all others. An amplifier increases signal strength and a detector demodulates the video signal. The signal is then split into two and a trap, or band reject filter, removes the sound IF before the signal is sent to the video signal processing circuit that drives the picture tube. On the other side, a filter, like Murata's SFSH series, removes the picture and chroma signals. A detector then demodulates the sound signal and it is sent to the speaker on the TV set.

The trap is a band reject filter meaning that it will allow all frequencies to pass through it except a certain band. In this application, the trap allows all frequencies except the sound IF to pass. Murata also produces SAW filters and discriminators for sound signal detectors.

Piezoelectric Traps

Introduction

Piezoelectric ceramic traps are band reject filters originally designed to remove the sound signal in a television receiver. The ceramic traps operate at the same frequencies as the MHz sound IF filters (3.58MHz to 7.0MHz). However, they have found wide use in other areas of the communications industry.

A band reject filter is a filter that allows all but a certain range of frequencies to pass unaffected. Figure 50 shows an example of an ideal band reject filter.

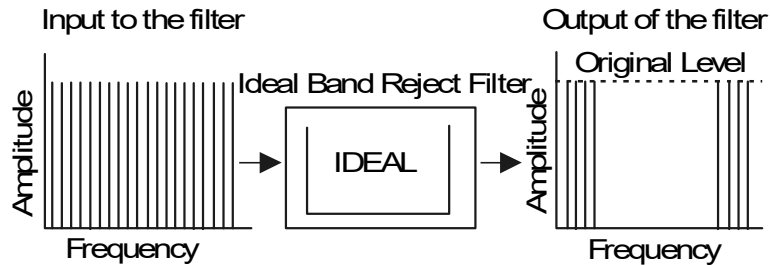

Figure 50: Ideal Band Reject Filter

Practically, such performance is not physically possible. There will be some attenuation of all frequencies and the sides of the band will not be perfectly straight. This is due to parasitic losses associated with the physical properties of the filter. Figure 51 shows a practical band reject filter.

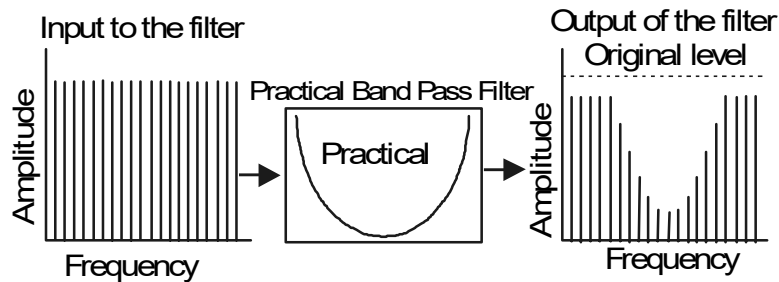

Figure 51: Practical Band Reject Filter

As can be seen from the figures, the outputs are quite different. The next section will go into how the trap works.

How Does It Work

A ceramic trap is essentially a ceramic resonator. It has the impedance response shown in Figure 52.

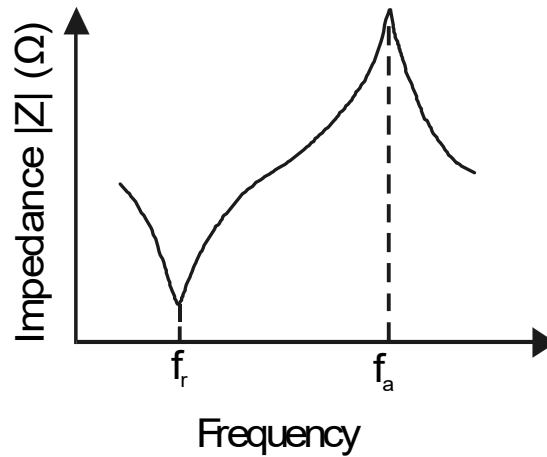

Figure 52: Resonator Impedance Response

A ceramic resonator has an impedance minimum at the resonant frequency, f_r , and an impedance maximum at the anti-resonant frequency, f_a . The resonator is designed so that the resonant frequency is at the frequency that is to be removed. The resonator is then placed to ground in the circuit (Figure 53).

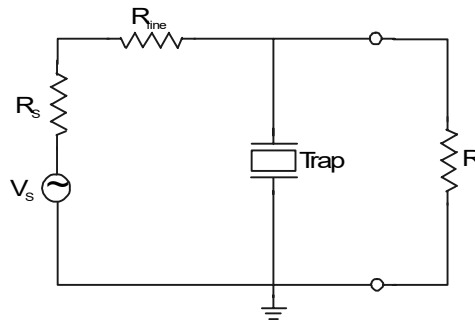

Figure 53: Single Element Trap Circuit

Frequencies at and near the resonant frequency see a low impedance to ground and are pulled down. All other frequencies see a large impedance and go past the trap to the rest of the circuit. The resulting filter trap response is shown in Figure 54.

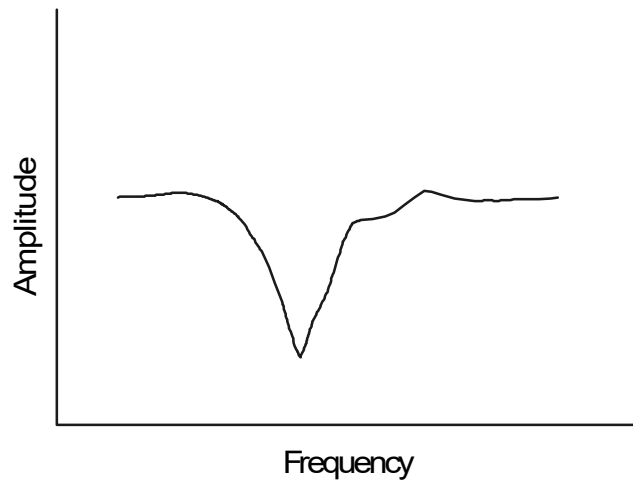

Figure 54: Trap Response

There are two types of trap: single element and double element.

- Single Element Trap

Single element traps have two terminals attached to electrodes on either side of a ceramic substrate (Figure 55).

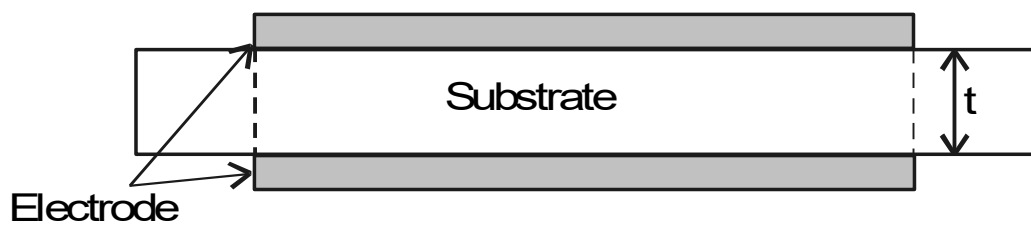

Figure 55: Single Element Trap

These traps are low cost, non-tunable devices that offer good attenuation over a set bandwidth.

- Double Element Trap

With a double element trap, one electrode is cut into two. This allows multi-coupling mode operation and provides better attenuation (Figure 56).

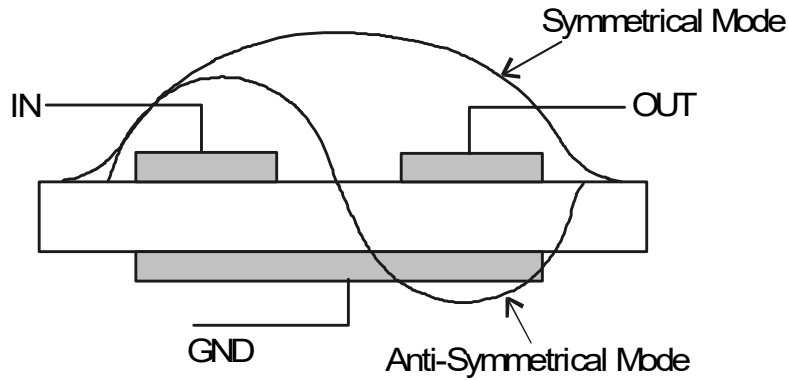

Figure 56: Double Element Trap

These traps provide better attenuation than the single element traps and are still non-tunable. One other difference is that the bandwidth of these traps can be changed by placing an inductor between the two terminals of the cut electrode (Figure 57). By changing the inductance of the inductor, the bandwidth can be altered to meet the needs of a specific application.

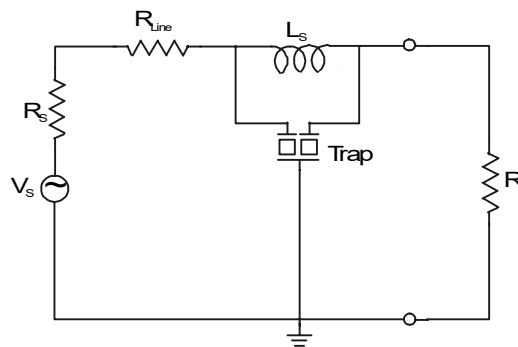

Figure 57: Double Element Trap Circuit

This circuit was simulated on a computer using four different values for the inductor. Figure 58 shows the resulting trap responses for the different values. Figure 59 shows the same responses over a narrower frequency range.

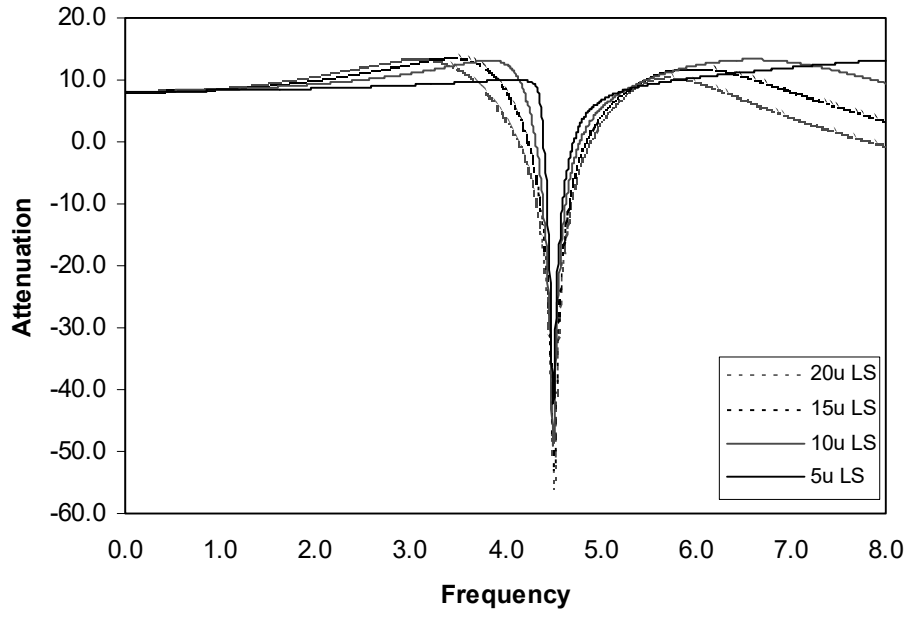

Figure 58: Computer Simulation of a Double Element Trap

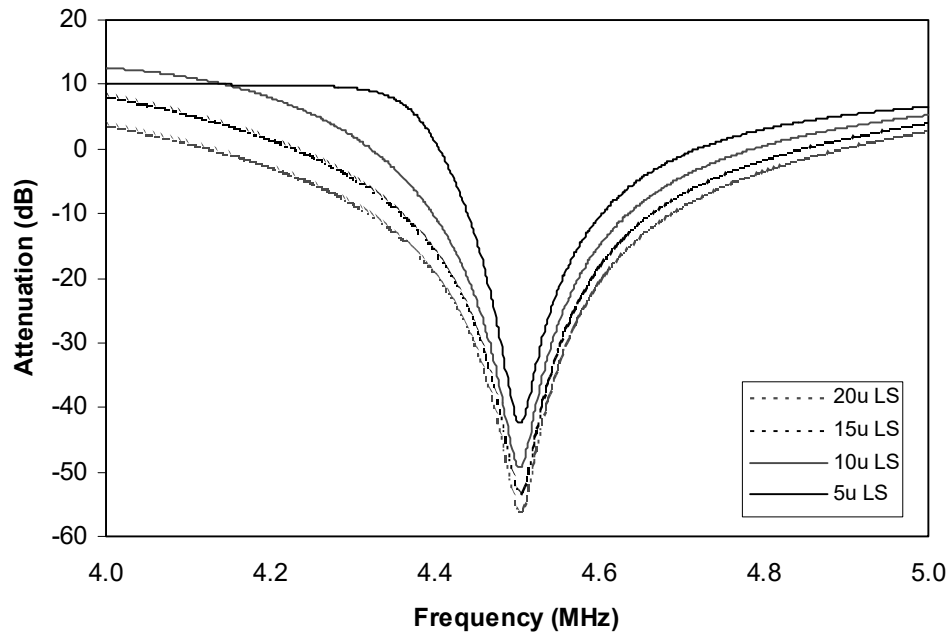

Figure 59: Computer Simulation of a Double Element Trap

Murata also makes traps with two and three responses for systems that have multiple IFs. As an example, the PAL TV system used primarily in Europe has multiple sound ifs depending on the language used. Multiple trap responses are needed to remove the signals that are in the undesired language.

Applications

Ceramic traps were originally designed to be used in TV receivers to remove the sound signal. Figure 60 illustrates a television signal.

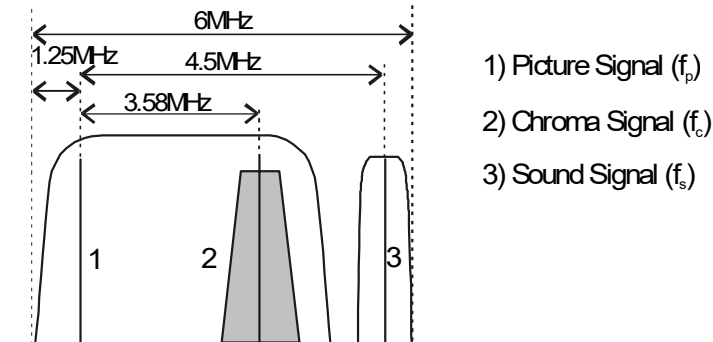

Figure 60: TV Channel Spectrum Description (NTSC-M)

The sound signal is centered at the high end of the channel while the picture and color or chroma signals are centered at the low end of the channel. Figure 61 shows a block diagram of a television receiver.

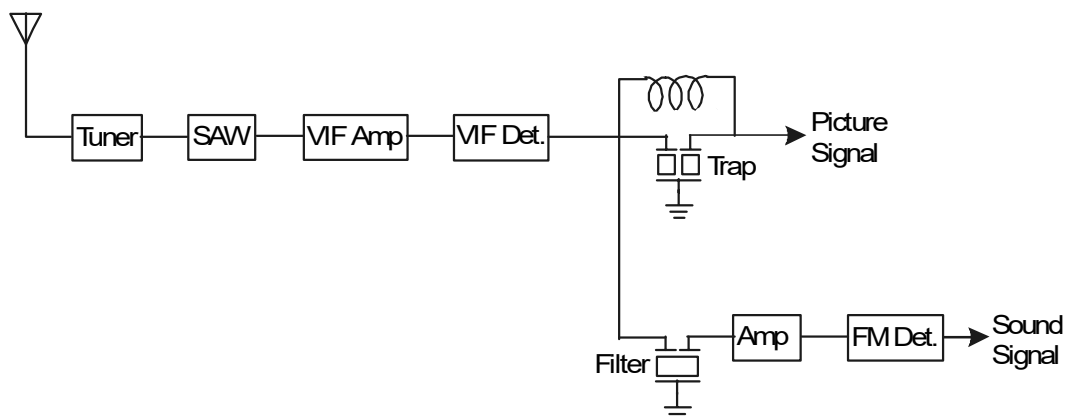

Figure 61: Inter-Carrier System

In the receiver, the tuner down-converts the desired channel to the IF frequencies. The SAW filter then selects the IF frequencies and the amplifier increases the signal strength. A VIF detector strips away the carrier wave from the picture signal. From here the signal is split into two. The first signal passes through a filter, which filters out the picture and chroma signals and passes the sound signal. It then goes to a detector, which strips away the carrier wave and then to the speaker on the television set. The second signal goes through the trap, which removes the sound signal and then to the video processing circuits that drive the picture tube. It is necessary to remove the sound signal because it could cause interference in the picture signal.

Parts

Figure 62 shows an example of the Murata part numbering system for ceramic traps.

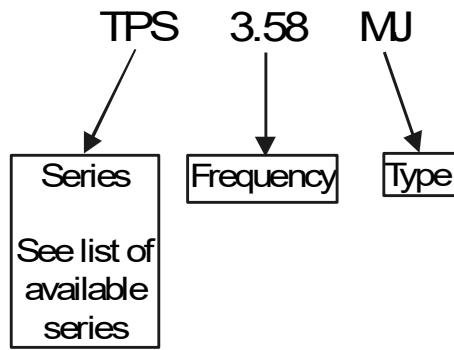

Figure 62: Trap Part Numbering system

Table 11 lists the different series of traps offered by Murata. Some older parts are listed for reference purposes, therefore if a part series has an asterisk (*) by it, then it is obsolete or no longer available for new designs.

Trap Series	Description
TPS...MJ	2 terminals, for sound IF in B/W receivers or chroma signal in video
TPS...MB*	3 terminals, 2 elements, for sound IF of TV/CATV receivers
TPSRA-M-B	3 terminals, 2 elements, for sound IF of TV/CATV receivers
MKT	High frequency trap

Table 11. Trap Series Description

Piezoelectric Discriminators

Introduction

Ceramic discriminators are designed to be used in quadrature detection circuits to remove a FM carrier wave. These circuits receive a FM signal, like in a FM radio, and send out an audio voltage, the music that comes out of the speakers. Ceramic discriminators replaced tuned LC tank circuits with a single, non-tunable, solid state device. In order to explain how a discriminator works, it is necessary to briefly explain frequency modulation.

Principles of Frequency Modulation

Frequency modulation (FM) is a method of placing a signal onto a high frequency carrier wave for transmission. The signal is usually an audio signal, such as voice or music, at a low frequency referred to as the audio frequency (AF). This is also referred to as the modulating signal since it is used to modulate the carrier wave. The carrier wave is a high frequency signal that is used to carry the audio signal to a remote receiver. This is referred to as the radio frequency (RF) signal. For FM, the frequency of the RF signal is varied instantaneously around the center frequency in proportion to the AF signal. As the voltage level of the AF signal increases, the frequency of the RF signal is increased. As the AF voltage decreases, the frequency of the RF signal is decreased. Figure 63 illustrates this.

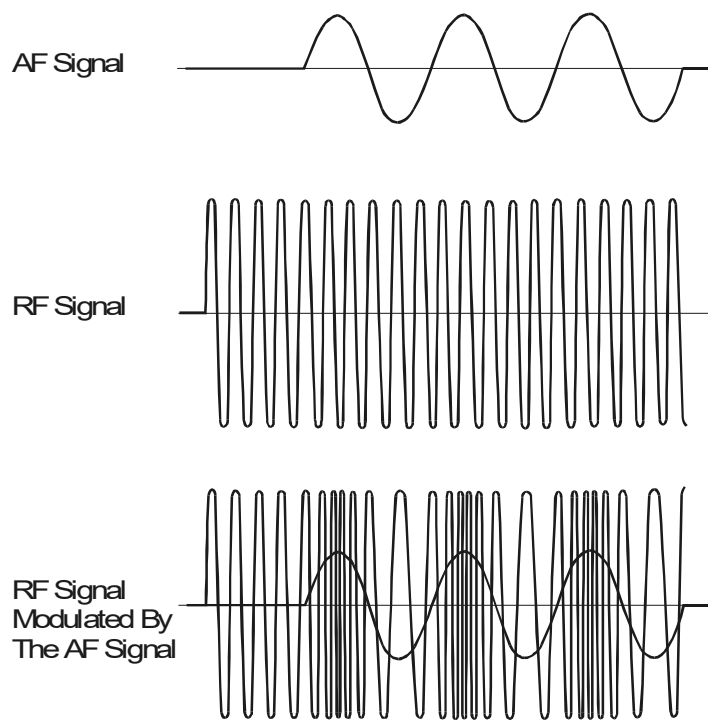

Figure 63: Generating An FM Signal

The difference between the highest frequency (when the AF is at a maximum) and the lowest frequency (when the AF is at a minimum) is called the frequency deviation. It is the function of the discriminator to recover the audio signal from this modulated RF signal by a method called quadrature detection.

Principles of Quadrature Detection

Quadrature detection is one method of stripping away a FM carrier signal and leaving the original transmitted signal.

The block diagram of a quadrature detector circuit is shown in Figure 64.

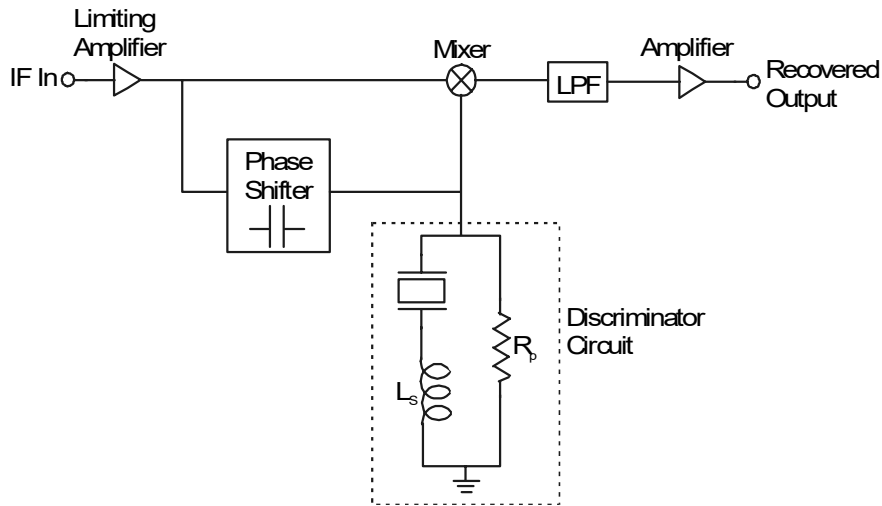

Figure 64: Block Diagram of a Quadrature Detection Circuit

First, the IF signal is passed through a limiting amplifier where any AM signal is removed. From here, the signal is split into two parts. The first part is sent to a phase shifter. This phase shifter is a capacitor, which adds a -90° phase shift to the signal. A discriminator circuit, consisting of a discriminator and a parallel resistor (a series inductor may or may not be included and will be discussed later in the text), then adds an additional phase shift to the signal. The amount of phase that is added depends on the instantaneous frequency of the RF signal. The signal is then sent to a mixer. The second part of the signal is sent straight to the mixer. A low pass filter then removes any high frequency noise and gives an average value for the mixer output. An amplifier then increases the signal strength. The limiter provides an output signal that has a constant amplitude, eliminating any noise or amplitude modulation that may be on the incoming signal. This stage also provides a balanced output, which is important for common-mode noise rejection. This section also provides automatic gain control because its output signal is between a minimum value and a maximum value, constant in amplitude. Figure 65 shows an example of a limiter circuit.

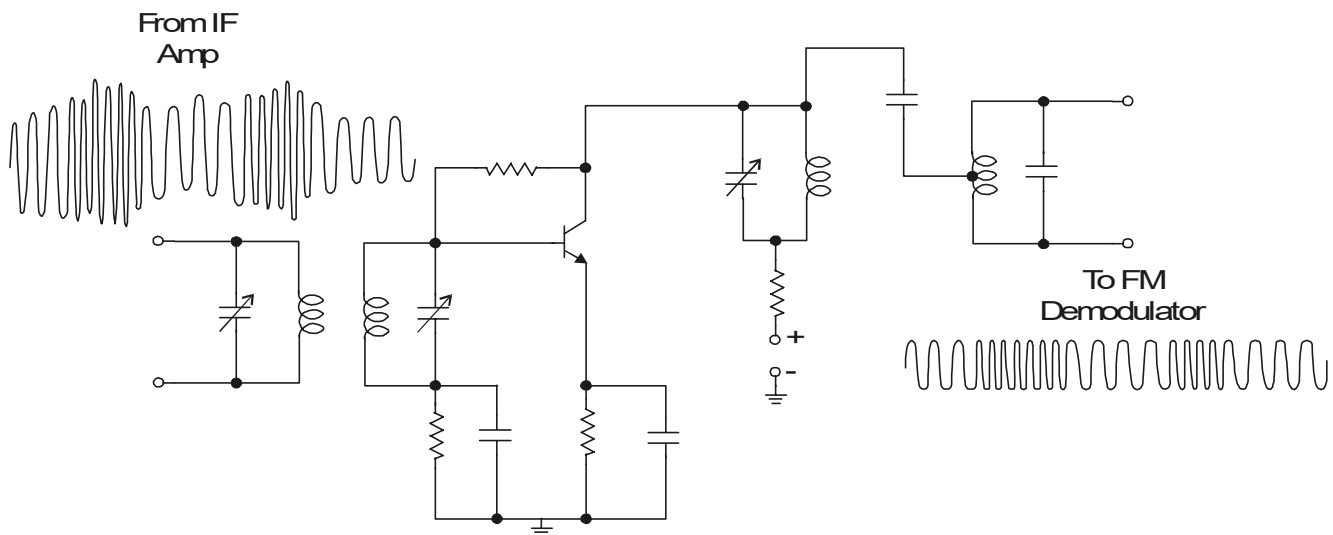

Figure 65: Limiter Circuit

From the limiter, the signal goes on to a balanced demodulator circuit, which includes the discriminator and the mixer

with a low frequency, thereby recovering the original audio signal (Figure 68)

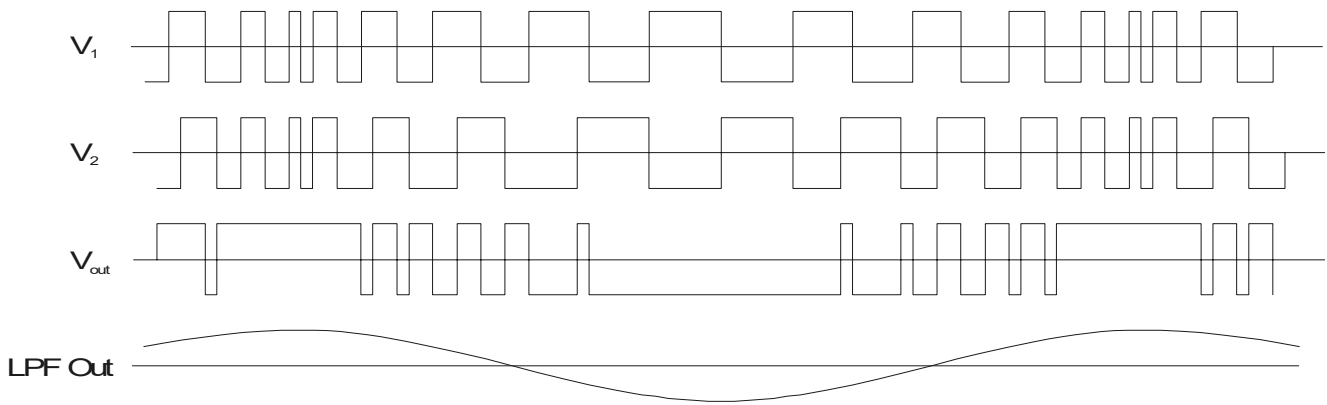

Figure 68: Input And Output Signals

The discriminator circuit was originally a LC tank circuit (Figure 69a). This circuit had to be hand tuned to the correct IF frequency. Ceramic discriminators replaced the tank circuit with a solid state device that does not require tuning (Figure 69b). The next section will discuss the operation of the discriminator.

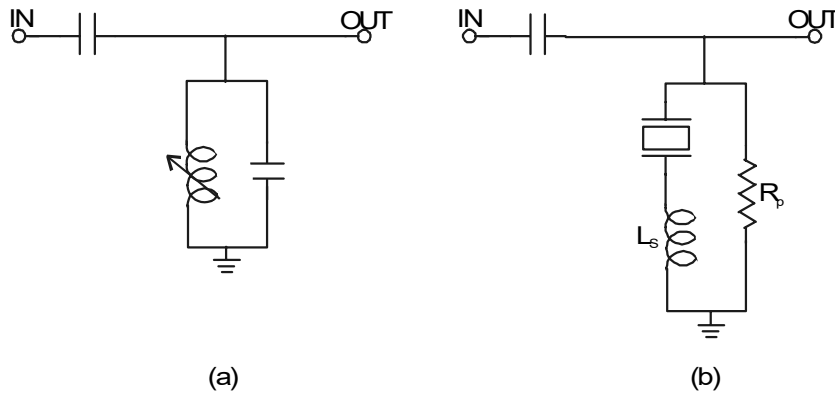

Figure 69: Discriminator Circuit

Principles of Bridge-Balance Detection

Another method of detection is to use a balanced bridge circuit. This circuit consists of 3 resistors and the discriminator connected in a bridge configuration. The output goes into a subtractor and then to the balanced demodulator circuit

shown earlier (Figure 70).

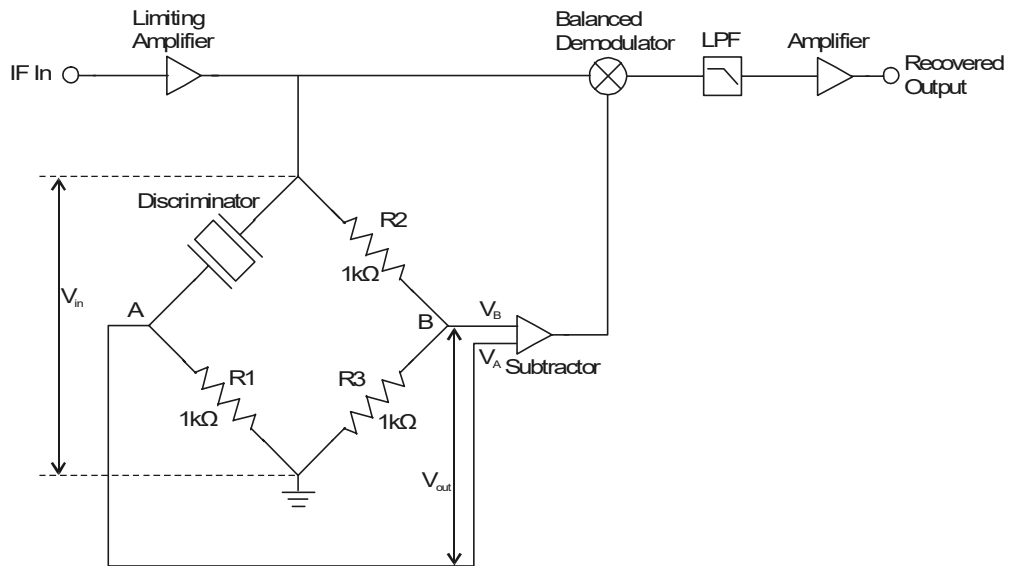

Figure 70: Balanced Bridge Circuit

This circuit utilizes both the impedance and phase responses of the discriminator. The discriminator is designed to be about $1k\Omega$ at the center frequency, so the other resistors are all $1k\Omega$. This means that as the frequency changes, the impedance and phase of the discriminator will change. This change will result in a phase shift being added to the original signal. The subtractor will take the voltage difference between points A and B and reference it to ground so that it can be fed into the balanced demodulator. Although the operation is different, the output signal of the subtractor is the same as the output signal of the quadrature detection circuit.

How Does It Work

Piezoelectric ceramic discriminators are similar to ceramic resonators. They have the impedance and phase response shown in Figure 71.

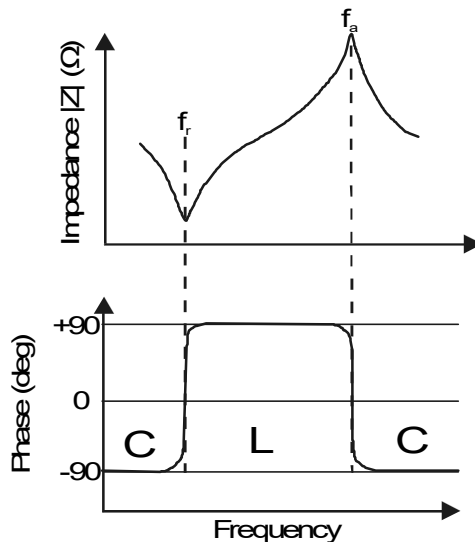

Figure 71: Resonator Impedance and Phase Plot

As can be seen from Figure 71, the impedance is a minimum at the resonant frequency, f_r , and a maximum at the anti-resonant frequency, f_a . Between these two frequencies the discriminator becomes inductive and is capacitive over all other frequencies. As stated earlier for the quadrature detection circuit, it is desired to add more phase to the lower frequencies and less phase to the higher frequencies. By adding a resistor in parallel with the discriminator, the anti-resonant impedance is lowered and the phase response is dampened. Figure 72 shows a computer simulation of the phase response of the resonator using different values for a parallel resistor.

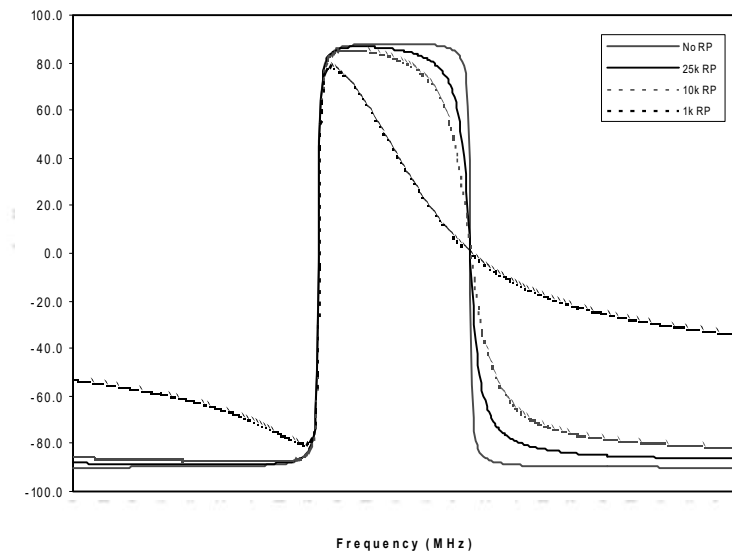

Figure 72: Computer Simulation of Resonator With Parallel Resistor

A series inductor increases the bandwidth, but this shifts the anti-resonant frequency to a higher frequency. Figure 73 shows a computer simulation of the phase response using different values for the series inductor. It also improves the symmetry of the output response. Since the inductor can also shift the center frequency of the discriminator, the design of the discriminator must compensate for this. The inductor is used for applications requiring a wide bandwidth and is generally not necessary for all applications. This manual shows the inductor in all of the circuits as a reference,

but the specific application and an IC characterization (Appendix 3) determine if it is really necessary.

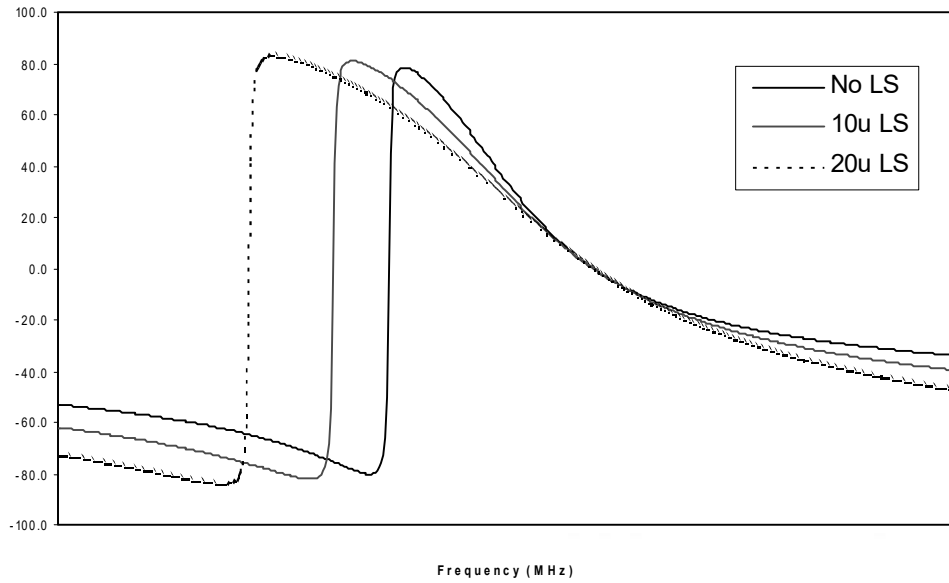

Figure 73: Computer Simulation of Resonator With Parallel Resistor and Series Inductor

From Figure 73, it can be seen that the lower frequencies would have the largest phase shift added and, as a result, would have the lowest output voltage. When a comparison is made between output voltage and frequency the result is

that the circuit has an S curve characteristic (Figure 74).

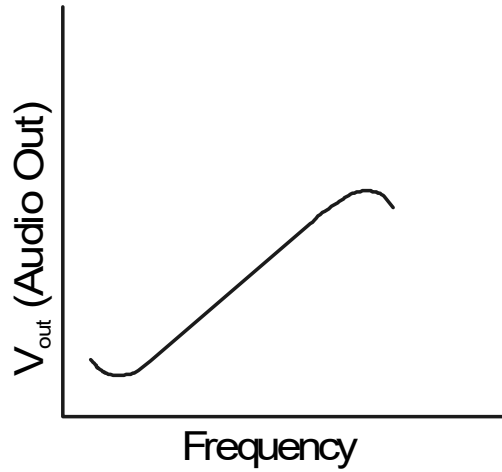

Figure 74: Discriminator S Curve Characteristic

When the discriminator is well tuned, the center of the S curve is at the IF frequency. This results in the best overall recovered audio or output voltage and also provides a margin against variations in the center frequency from part to part (Figure 75).

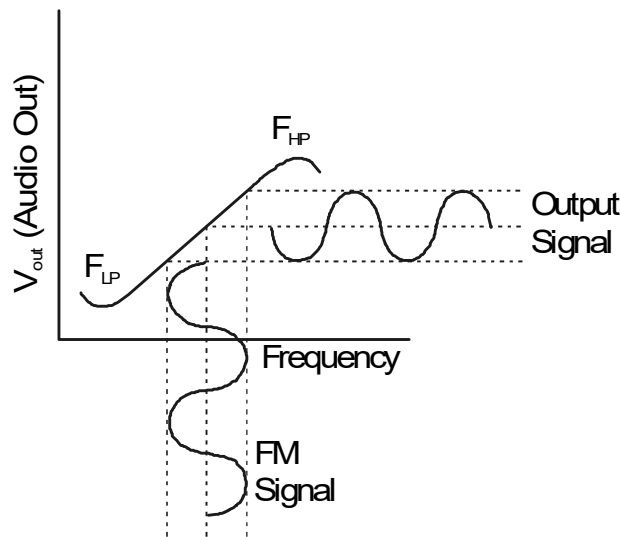

Figure 75: Well Tuned Discriminator

If the discriminator is poorly tuned and the center of the S curve is not near the center frequency, then the recovered

audio and the bandwidth would be decreased (Figure 76).

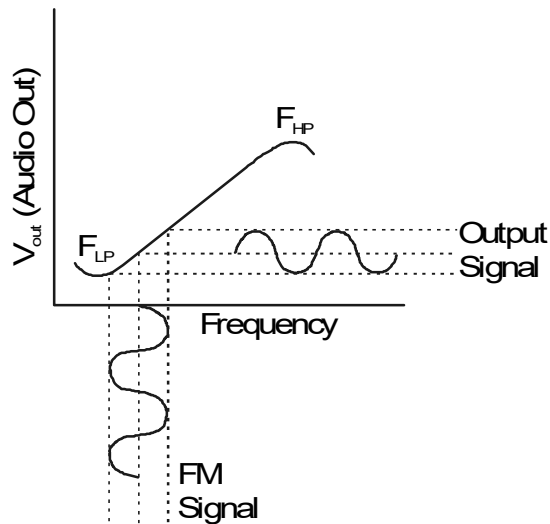

Figure 76: Poorly Tuned Discriminator

If the signal were at the minimum, F_{LP} or maximum, F_{HP} of the S curve, then the recovered audio would be a minimum and the signal would be distorted. As can be seen in Figure 77, the lower half of the wave is flipped up and a series of humps results. This leads to a completely unrecognizable output signal.

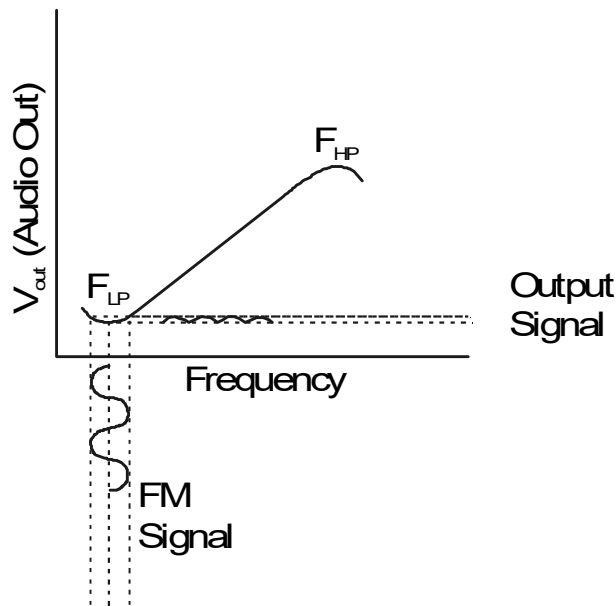

Figure 77: Distorted Output Signal

Peak separation is the distance between F_{LP} and F_{HP} . A wider peak separation gives more linear characteristics at the

center of the S curve and a wider bandwidth, but it also gives a lower recovered audio voltage (Figure 78).

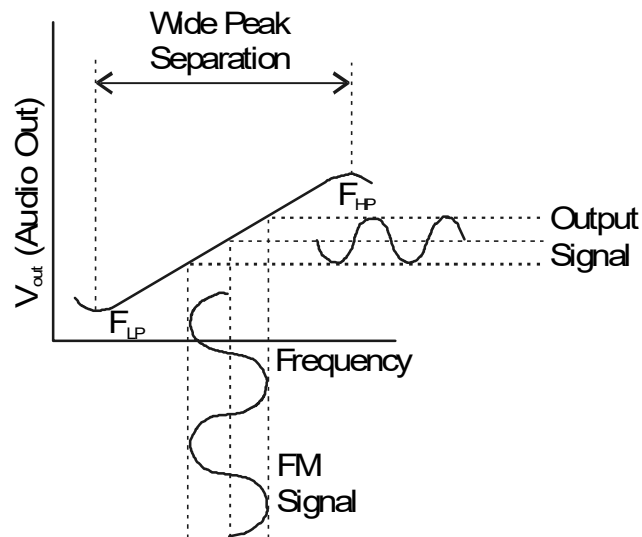

Figure 78: Wide Peak Separation

A smaller peak separation has a smaller bandwidth but gives a larger recovered audio voltage (Figure 79).

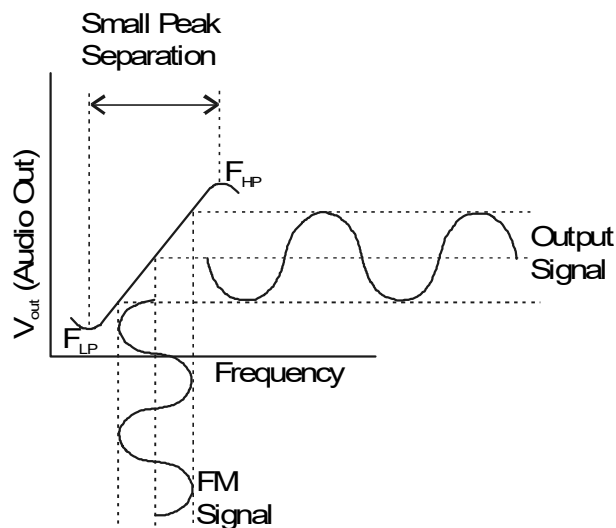

Figure 79: Narrow Peak Separation

Figure 80 shows an example of recovered audio data. Frequencies near the center frequency result in the largest output voltage. The 3dB frequencies are the two points where a line 3dB down from the maximum recovered output intersects the curve. The 3dB bandwidth is the range of frequencies between these two points, and should be close to the

frequency deviation. The two minimum points on the recovered audio curve correspond to F_{HP} and F_{LP} of the S curve.

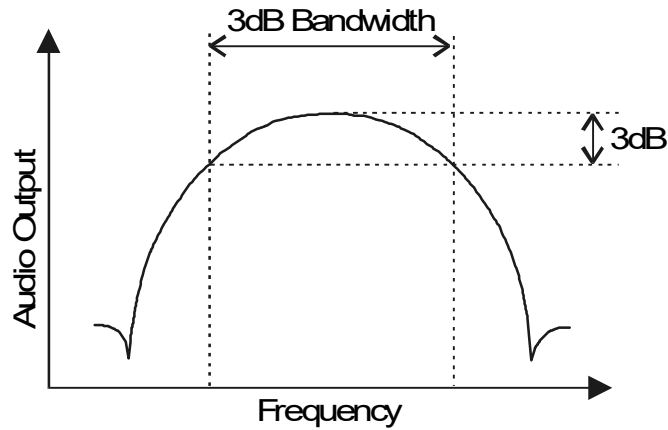

Figure 80: Recovered Audio Curve

Some distortion is introduced by the discriminator because it is not a truly linear device., as shown by the “S” curve in Figure 81.

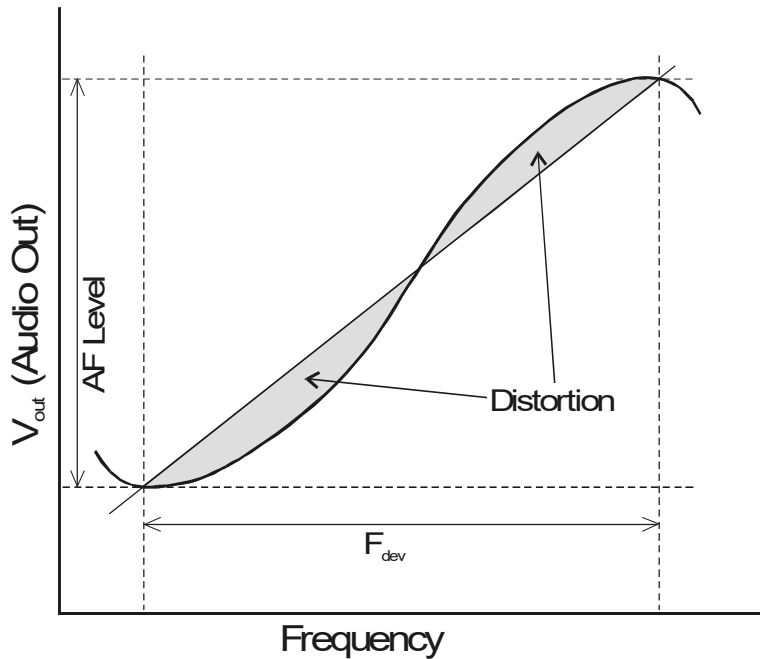

Figure 81: Discriminator Distortion

This distortion is smallest at the center frequency of the discriminator where the discriminator is at its most linear point. This distortion can be compensated for in the design of the circuit and minimized by a good discriminator. Figure 82 shows an example of a graph of recovered audio and total harmonic distortion for the quadrature detection circuit. The bridge detection circuit has a more linear phase characteristic, resulting in a wider bandwidth and flat distortion (Figure

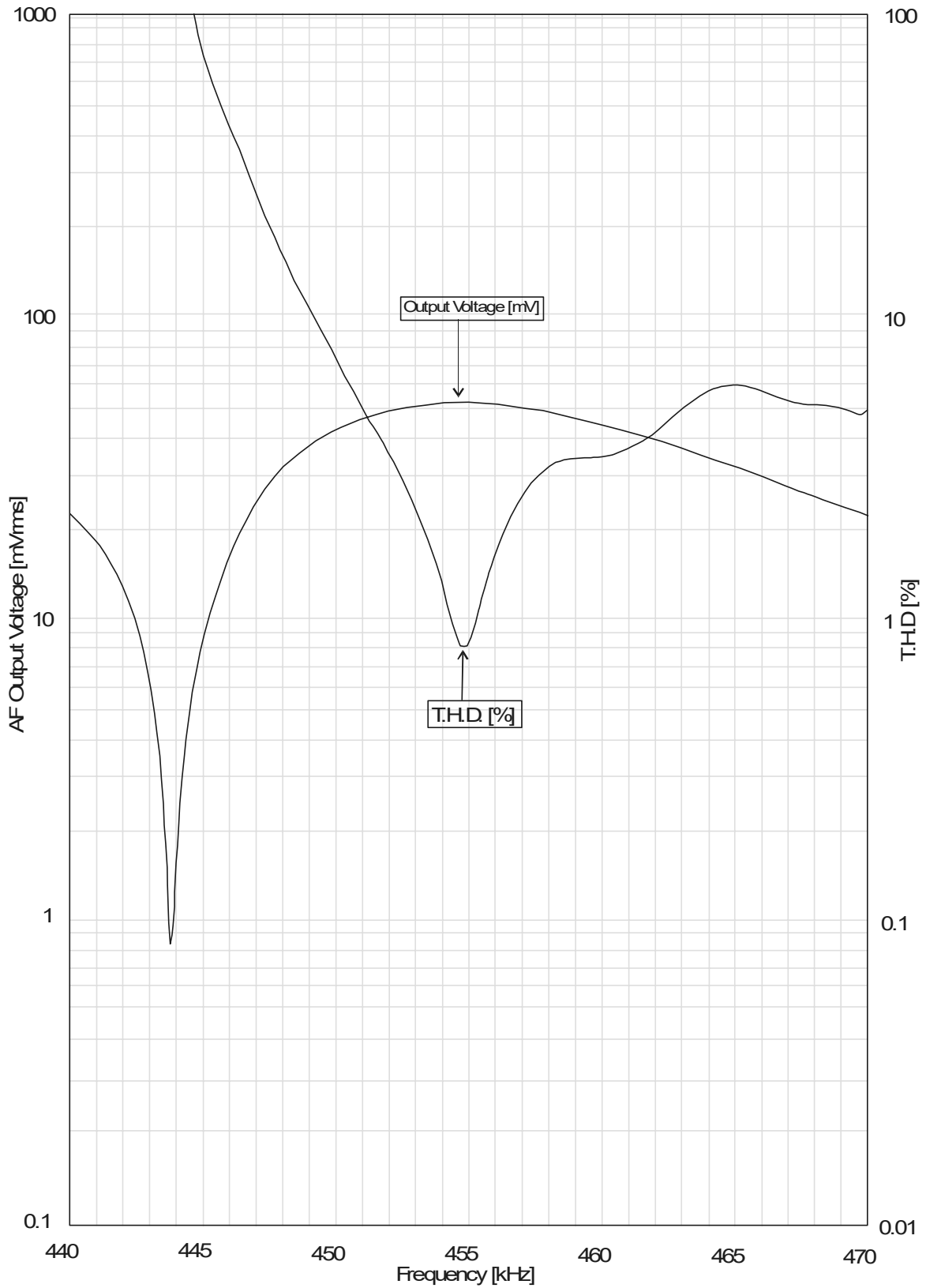

Figure 82: Example of Recovered Audio and Total Harmonic Distortion for Quadrature Detection

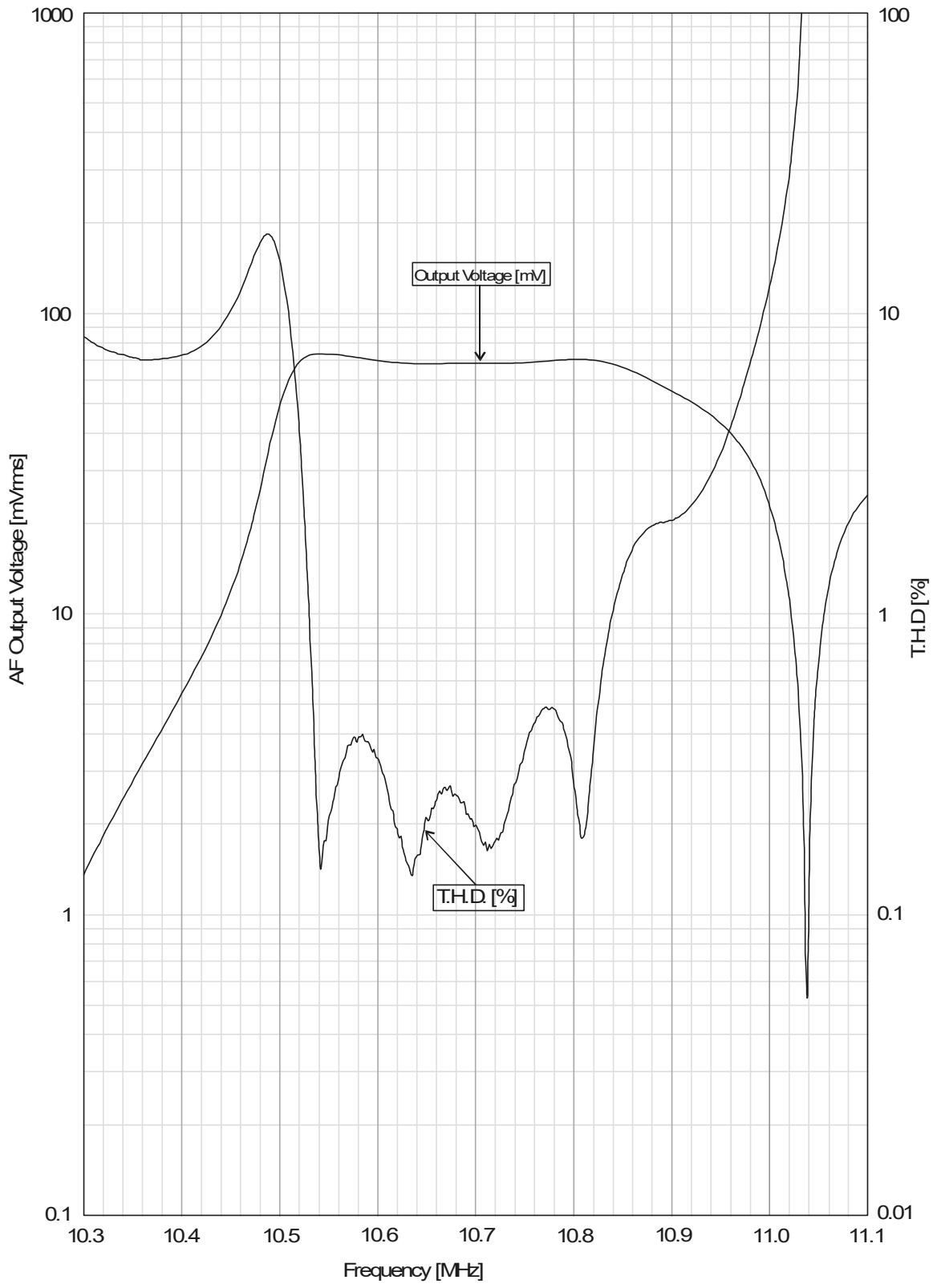

Figure 83: Example of Recovered Audio and Total Harmonic Distortion for Bridge Detection

Applications

IC Characterization Service

The ceramic discriminators produced by Murata may or may not work with all chips using standard external circuit values. This is mainly due to typical variations in IC manufacturer detection circuits, part family to part family or IC maker to IC maker. In order to assist our customers with their designs, Murata offers a chip characterization service free of charge. The chip that our customer is using is tested with the Murata discriminator and the discriminator frequency will be adjusted for the particular IC. Murata provides the engineer the recommended Murata part number that should be used with their target IC and the recommended external hook up circuit for this target IC. This enables the designers to adjust their designs so that the discriminator will work every time. These adjustments can be as simple as adjusting component values or as complicated as redesigning the entire circuit. Murata Electronics sales representatives are able to arrange IC characterizations. Please try to start the IC characterization process with Murata as soon as possible, since it does take time to do an IC characterization and there can be several customers at any one time waiting for this service. Please see Appendix 3 for more information on this service and the needed forms.

Piezoelectric ceramic discriminators are used in the detector stage of receivers. In Figure 84, the detector block is the circuit shown in Figure 64. The output of this circuit would then go to a speaker.

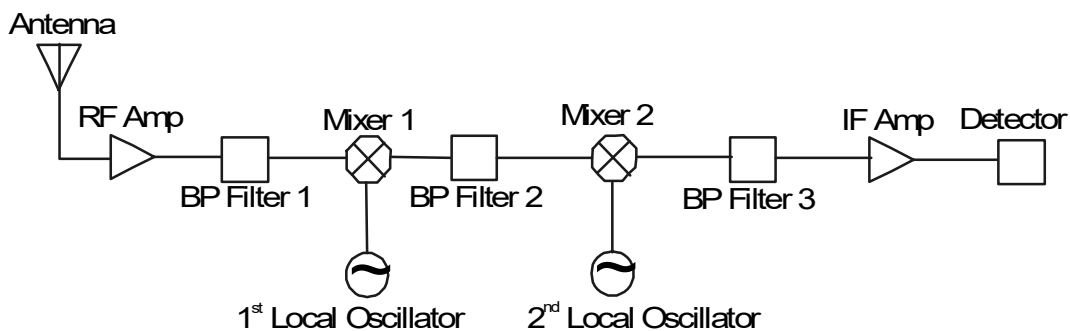

Figure 84: Double Super Heterodyne Receiver

Parts

Figure 85 gives an example of the Murata part numbering system for discriminators.

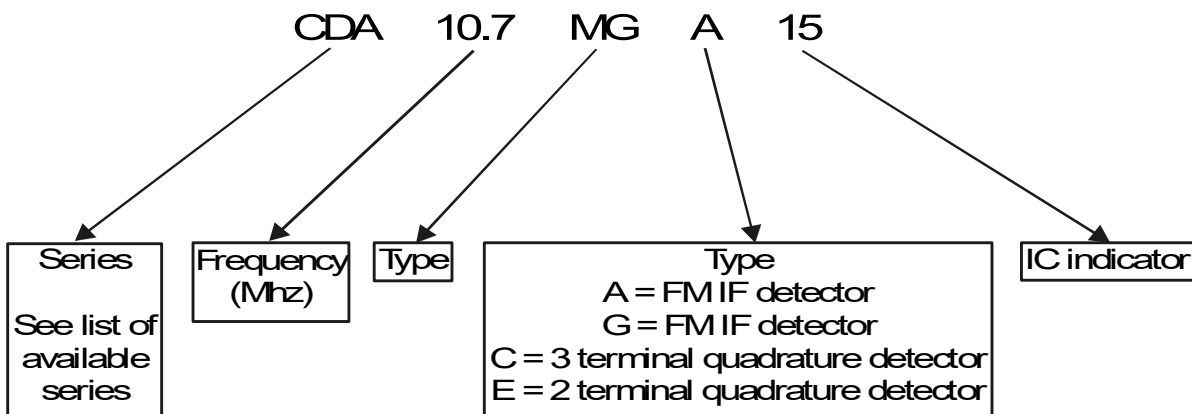

Figure 85: Discriminator Part Numbering System

Table 12 lists the different series of discriminators offered by Murata and gives a brief description of each series. Some older series are shown for reference purposes, so all series with an asterisk (*) are not available for new designs and may be obsolete

Discriminator Series	Description	SMD/Leads
CDA...MG	Wide bandwidth, low recovered audio, 2 terminals	Leads
CDA...MC	Narrow Bandwidth, high recovered audio, 2 terminals	Leads
CDA...MA	3 terminal device	Leads
CDA (4.5-6.5) ME(MD)*	Quadrature detection, 2 terminals	Leads
CDA (4.5-6.5) MC*	Differential Peak detection, 3 terminals	Leads
CDSH(4.5-6.5) ME	Quadrature detection, 2 terminals	Leads
CDSH(4.5-6.5)MD	Differential Peak detection, 2 terminals	Leads
CDSH(4.5-6.5) MC	Quadrature detection, 3 terminals	Leads
CDB...C	kHz discriminator, no series inductor	Leads
CDBM...C	Miniature version of CDB...C	Leads
CDB...CL	Wide bandwidth, used with series inductor	Leads
CDBM...CL	Miniature version of CDB...CL	Leads
CDBC...CX	Not used with series inductor, narrow bandwidth, 2 terminals	SMD
CDBC...CLX	Used with series inductor, wide bandwidth, 2 terminals	SMD
CDBCA*	Surface mount device, 2 terminals + 1 dummy terminal	SMD
CDACV	MHz surface mount discriminator	SMD
CDSCA	MHz surface mount discriminator	SMD

Table 12. Discriminator Series Description

Appendix 5 shows a list of ICs that have been characterized by Murata and the recommended discriminator for each IC.

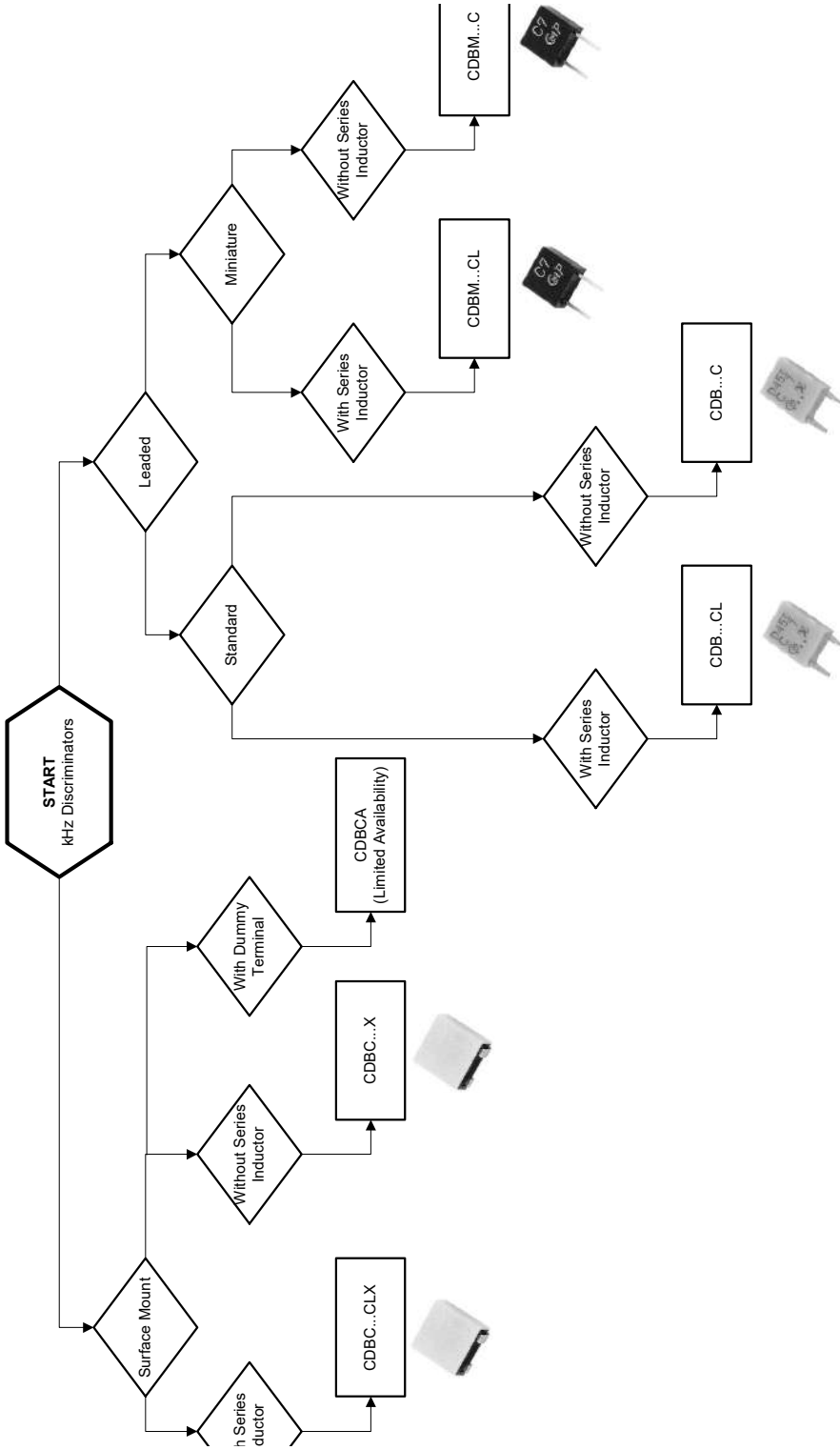

Figure 86: kHz Discriminator Selection Chart

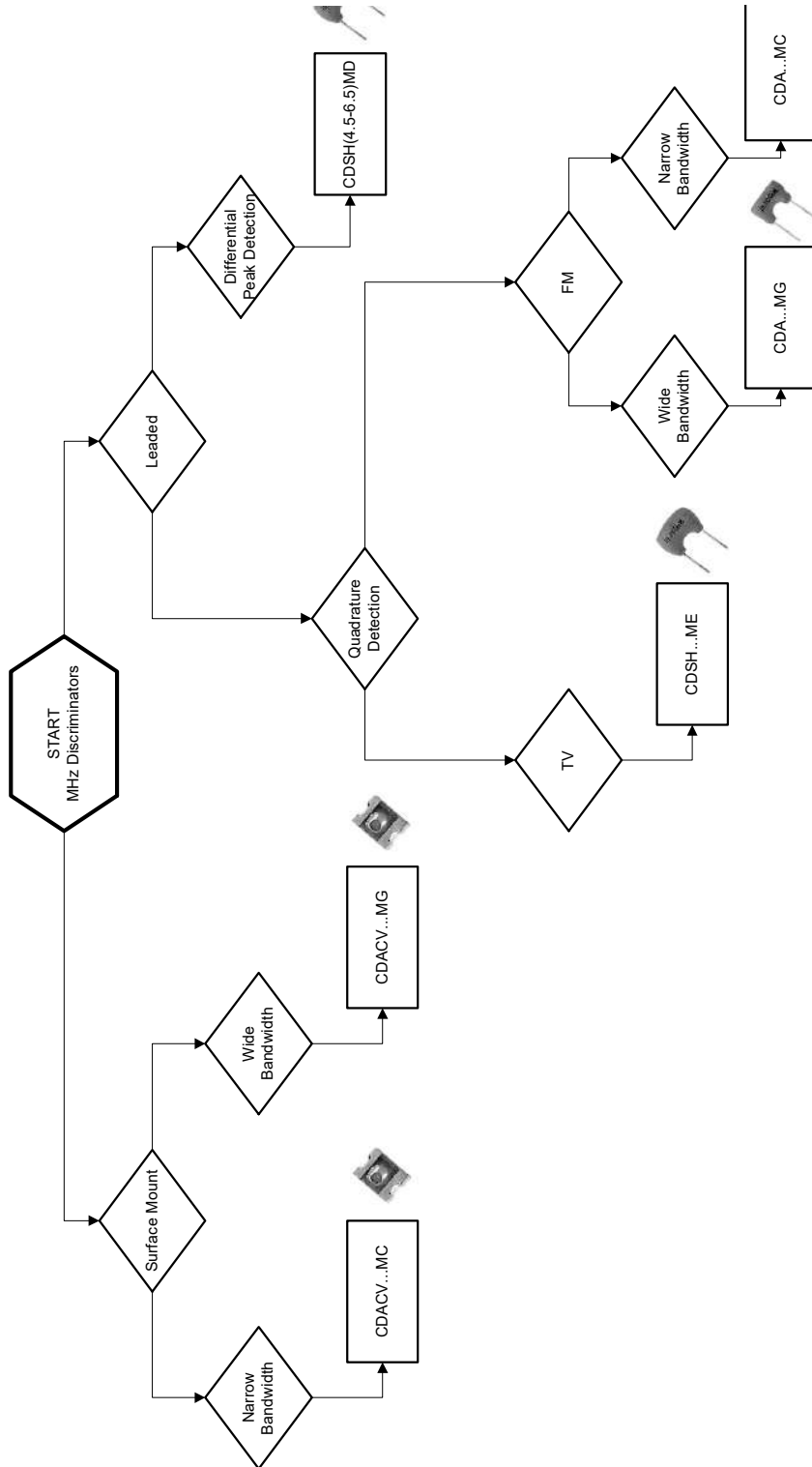

Figure 87: MHz Discriminator Selection Chart

Surface Acoustic Wave Filters

Introduction

Surface acoustic wave (SAW) filters provide excellent filtering properties at high frequencies. This makes them suitable for use in many wireless communications products such as cellular telephones, cordless telephones, TVs, VCRs, cable modems, and pagers.

How Does It Work

SAW filters use Inter Digital Transducers (IDT) as the input and output electrodes mounted on a piezoelectric substrate. An IDT is a comb structure consisting of interleaved metal electrodes, called fingers, attached to a bus bar (Figure 88).

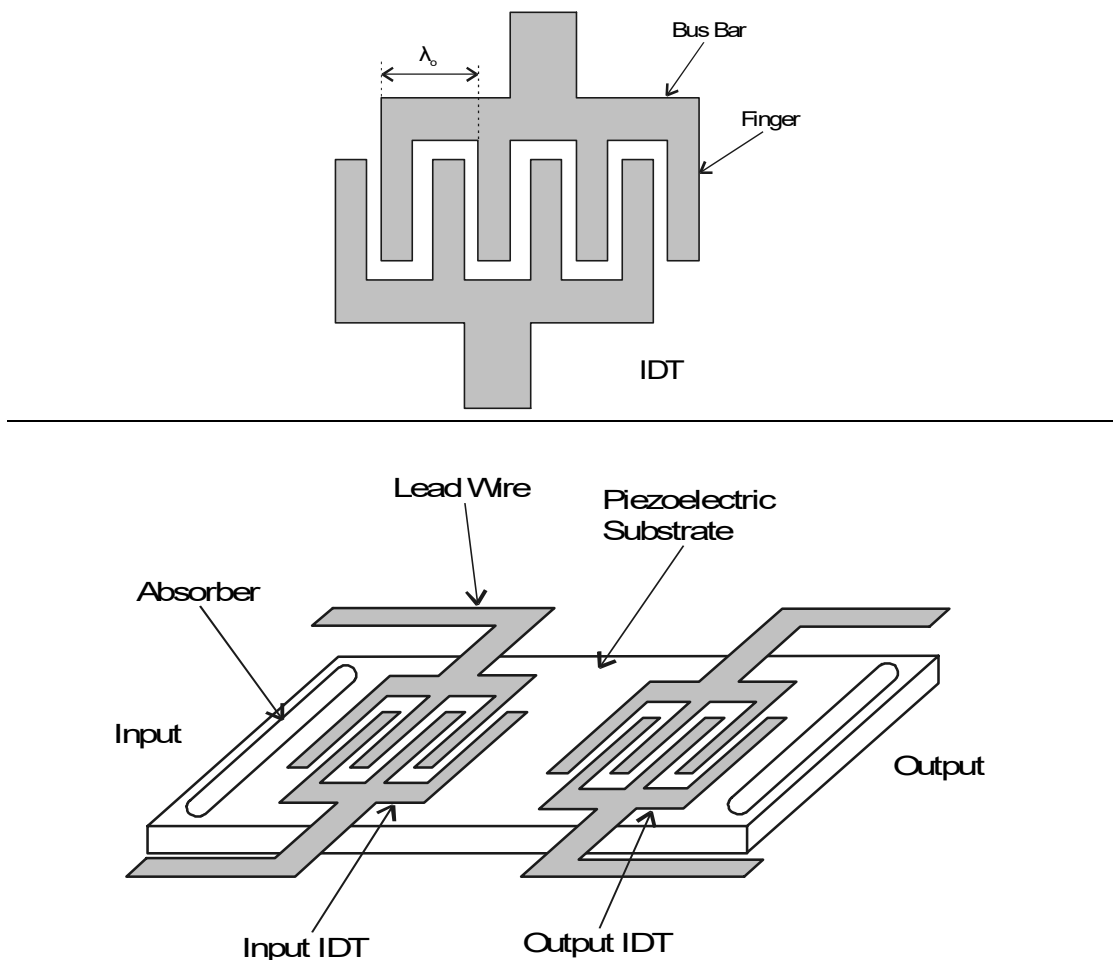

Figure 88: SAW Filter Construction

By applying a signal at the input terminal, stress is created between the electrodes by the piezoelectric effect. This stress causes the substrate to shrink and expand, forming a surface acoustic wave which propagates along the substrate to the output IDT. At the output IDT, the wave causes a potential difference between the electrodes, which is then seen as a voltage at the output terminals. The maximum amount of energy transfer occurs when the wavelength of the surface acoustic wave is the same as the distance between electrodes, λ_0 . All other wavelengths are attenuated. Because of this, adjusting the pitch of the electrodes sets the center frequency of each overlapping finger section. This procedure is called variable pitch. Adjusting the finger overlap length can change the magnitude of the signal transmitted or received by each overlapping finger section. This procedure is called apodization. This is a transversal filter that enables the amplitude and GDT characteristics to be designed separately. This allows a flat passband, good

selectivity, and a flat GDT to be achieved (Figure 89). A wide range of frequency characteristics can be realized just by the design of the IDT electrode pattern. Since the signal is propagated in both directions from the IDT, silicon absorbers are placed at the edges of the substrate to prevent reflections from the edge that would cause distortion.

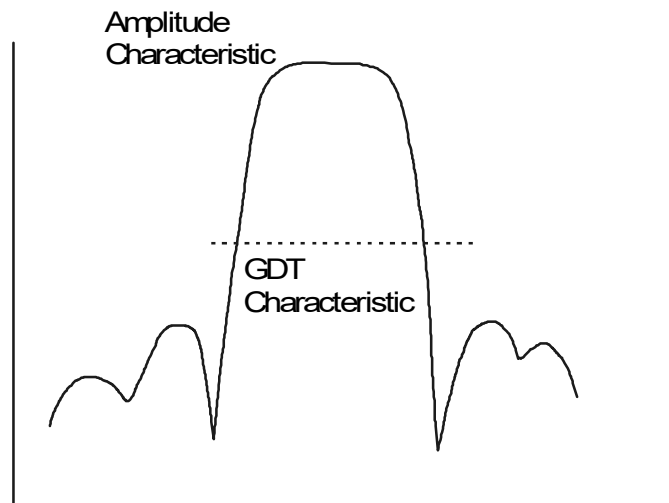
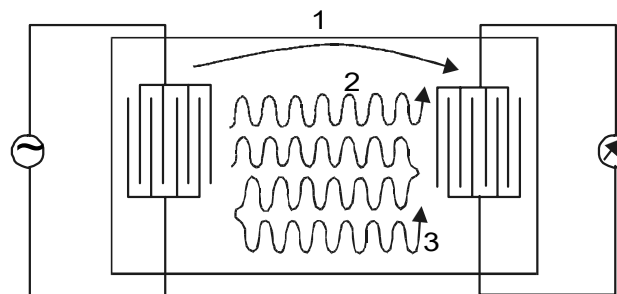

Figure 89: SAW Filter Characteristics

Causes of Signal Distortion

There are two main causes of distortion in SAW filters. The first is called direct breakthrough. This is when the signal is powerful enough to be picked up at the output without having traveled through the piezoelectric material. The signal is seen at the output attenuated but unfiltered before the filtered signal is seen. The other type of distortion is called triple transit echo (TTE). This is a result of the signal bouncing between the two IDTs. If the signal takes time τ to be seen at the output then the TTE signal will be seen 2τ after the main signal. Figure 90 illustrates the signal paths and Figure 91 shows the input and output as a function of time.



- 1) Direct Breakthrough
- 2) Main Signal
- 3) T.T.E.

Figure 90: SAW Filter Signal Paths

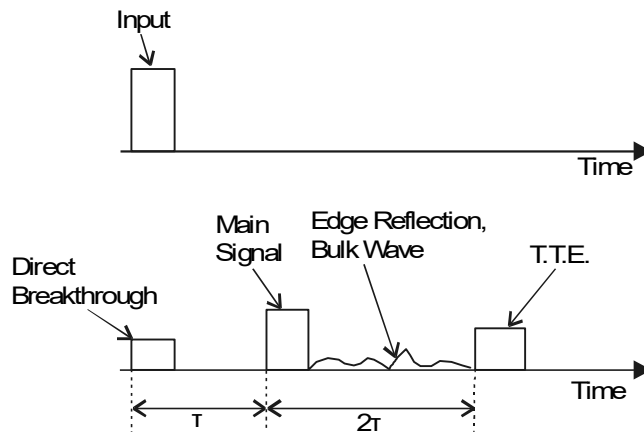

Figure 91: SAW Filter Signal Timing

TTE tends to cause a ripple in both the amplitude characteristic and in the GDT, which can cause errors in digital systems, and in the amplitude characteristic, which results in signal distortion. In TVs, because of the delay, this can cause a ghost image to the right of the main image. Direct breakthrough also causes ripples in the GDT and amplitude characteristics as well as deterioration in attenuation level outside the pass band. Signals that should not pass could then cause interference later in the circuit. In TVs, this can cause a ghost image to the left of the main signal.

In order to minimize the signal attenuation in the filter it is desirable to minimize the insertion loss in the filter. The insertion loss is not the same as the power loss. We distinguish between power loss and insertion loss in the following way: insertion loss is the ratio of output voltage when the filter is shorted to the maximum output voltage when the filter is inserted; power loss is the ratio of the available power of the source to the power supplied to the load. Numerically,

$$\text{Voltage loss} = 20 \log \left(\frac{V_S}{V_L} \right)$$

$$\text{Insertion Loss} = \text{Voltage Loss} - 20 \log \left(\frac{R_S + R_L}{R_L} \right)$$

$$\text{Power Loss} = \text{Voltage Loss} + 10 \log \left(\frac{R_L}{4R_S} \right)$$

Where:

V_S = source voltage

V_L = load voltage

R_S = source resistance

R_L = load resistance

Common practice to reduce insertion loss is to conjugately match the input and output impedances. SAW filters have a capacitive component in input and output impedance, which can be cancelled by adding inductors. The purely resistive components of the filter impedance can be matched with R_S and R_L . However, the TTE level and power loss are inversely related: when the power loss is reduced the TTE increases. As a result, it is necessary to greatly mismatch the filter. For practical uses a -40dB suppression of TTE is required which requires a theoretical power loss larger than 16dB . Adding a safety margin, the actual power loss should be greater than 18dB .

The level of direct breakthrough has three main causes. The first is electrostatic causes like stray capacitances. The second is electromagnetic inductions due to the currents passing through the printed pattern. To limit these effects, the printed input and output patterns should be made small and short and the VIF stage should be shielded from the other stages. The last cause is ground loops. There are a number of places on the board where the earth grounds are mutually connected. These should be cut where possible to limit the number of loops.

Applications

Television, Cable, and VCR

The most common use of SAW filters is in television receivers. A television signal has three parts: a sound signal, a picture signal, and a color or chroma signal. These three signals are placed in a 6MHz frequency band called a channel. Within the 6MHz band, the video carrier is centered at 1.25MHz from the low end and the sound carrier is centered at 250kHz from the upper end. This leaves a 1.5MHz guard between the adjacent channels to prevent interference. The chroma carrier is centered at 3.58MHz from the video carrier. Figure 92 illustrates the television signal.

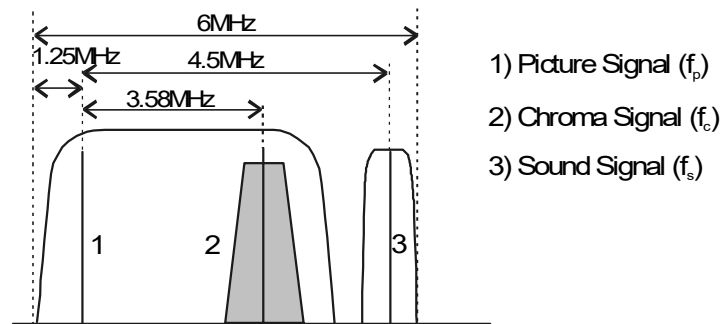

Figure 92: TV Channel Spectrum Description (NTSC-M)

Television receivers all have the same basic parts. The first part is an antenna or, in the case of cable television, a cable. The antenna receives all channels simultaneously, spread across the frequency spectrum. The next part is a tuner that selects the desired channel by using a local oscillator to bring the channel frequencies down to the IF frequencies. The IF frequencies are the frequencies that the rest of the receiver is tuned to and uses to produce the picture and sound. The oscillator frequency is adjusted by the user and forms a reference signal. All of the signals from the antenna are subtracted from the reference signal and the desired channel is reduced to the IF frequencies and reversed. For example, channel 6 lies in the range from 82 to 88 MHz. As stated before, the video carrier is 1.25MHz above the low end, which is 83.25MHz, and the sound carrier is 4.5MHz above this, or 87.75MHz (Figure 93a). The standard IF frequencies in the U.S.A. are 45.75MHz for the picture and 41.25MHz for the sound. By tuning the oscillator to 129.00MHz, the channel 6 video carrier becomes $129 - 83.25 = 45.75$ and the sound carrier becomes $129 - 87.75 = 41.25$. This reduces the signal to the IF frequencies and inverts the signal, the video signal is now higher than the sound signal (Figure 93b). All of the frequencies in the antenna are treated in this manner and then sent to the next stage.

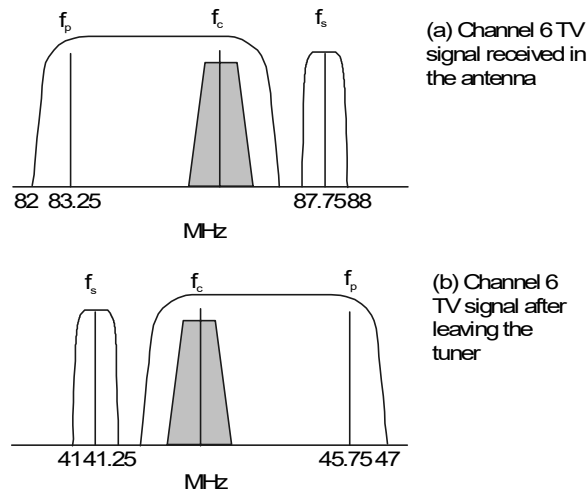

Figure 93: TV Channel Conversion

The third stage is a SAW filter. This filter selects the signals only in the IF frequencies. All others are rejected. To continue the example above, the tuner has reduced the channel 6 signals to the IF frequencies. Since the SAW filters only pass the IF frequencies, only the channel 6 signals are sent on to the rest of the receiver. This stage begins what is called the tuned part of the receiver. The rest of the receiver is adjusted so that only the signals in the IF frequencies are seen or manipulated and the operator does not have to adjust anything else.

The next part is an amplifier that increases the signal strength. The amount of energy received at the antenna is very small and even more is lost in the previous stages. This stage boosts the strength to a point that the following stages can more effectively use.

The next stage is an IF detector that strips away the carrier signals reducing the signals to the baseband (0 – 6MHz) and inverting them using the same method as the tuner.

Next the signal is split two ways. One part is passed through a filter that selects only the sound information. This information is passed to an amplifier and then to a FM detector where the signal is demodulated. From here the signal goes to the speaker on the TV. The other part is passed through a trap that selects only the picture and chroma information. This information is sent to an amplifier and then to the picture tube circuitry.

This is the basic idea behind the receiver, though there are a few different kinds with slightly different designs.

Figure 94 shows a diagram of a basic receiver and the resulting signal after each section.

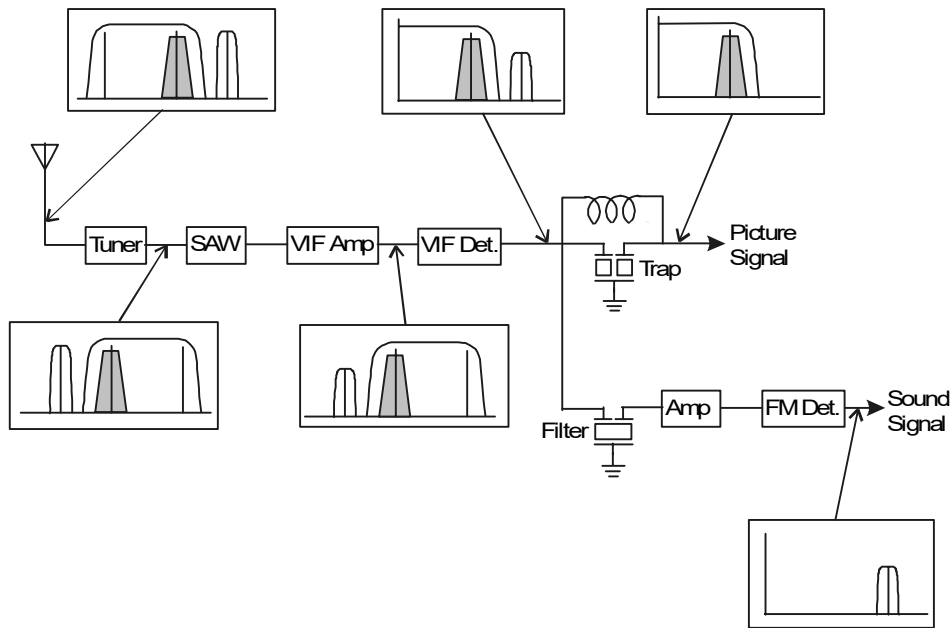

Figure 94: TV Signal In A Receiver

Types of TV, VCR, and Cable Receiver

There are three main kinds of receiver used in television, cable, and VCRs. The first is the inter-carrier system (Figure 95). This system is the basic system described above. This is the cheapest and simplest system but suffers from “buzz” which results from the picture signal breaking into the sound signal.

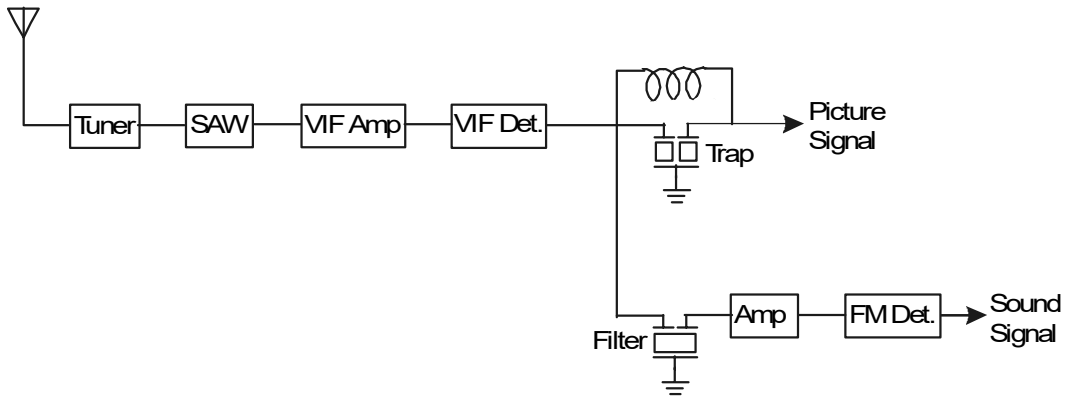

Figure 95: Inter-Carrier System

The second kind of receiver is called the quasi-parallel system (Figure 96). This system has two SAW filters after the tuner: one to select the picture and chroma IFs and one to select the sound and picture IFs. The picture and chroma signals go through the amp, VIF detector, and trap as before. The sound and picture signals go through an amplifier and then to an SIF detector where the picture signal is used as a reference to strip away the sound carrier signal. A filter then removes the picture signal, an amplifier increases the signal strength, and a FM detector demodulates the sig-

nal. This system has better signal separation than the inter-carrier system.

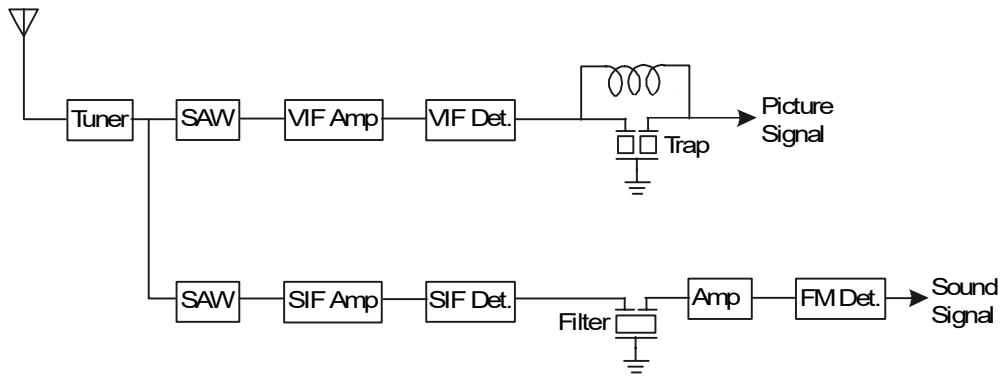

Figure 96: Quasi-Parallel System

The last receiver is called the split-carrier system (Figure 97). It is similar to the quasi-parallel system except that the SIF detector is replaced by an oscillator that converts the sound signal down to the sound IF frequency. Because of this the picture signal is not needed as a reference so the SAW filter selects only the sound IF. This system has the best signal selection and the most complicated design.

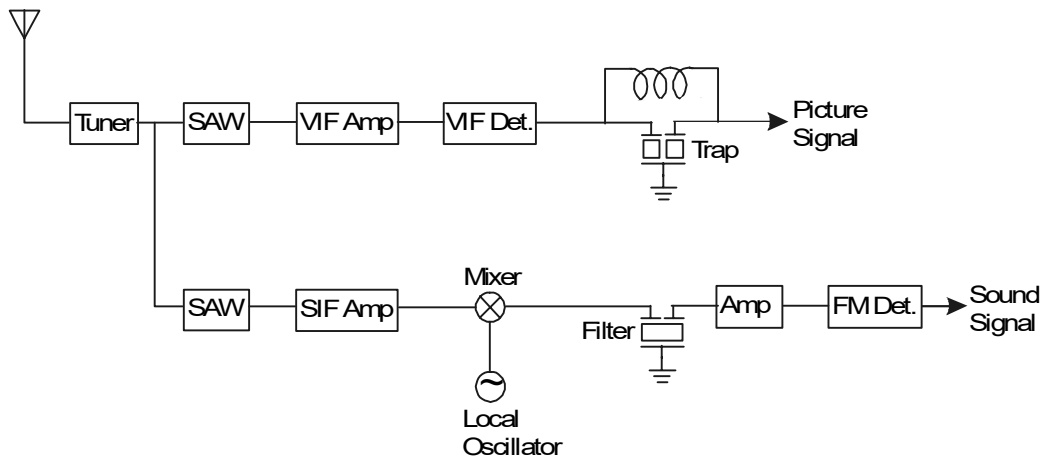

Figure 97: Split-Carrier System

Connection of the SAW Filter to Other Stages

The most common way of compensating for the high insertion loss of the SAW filter is by inserting an amplifier. Where the amplifier is inserted and how the stages are connected becomes important to reducing losses and distortion. When the amplifier is placed before the filter, it is called a preamplifier system. Input impedance matching is accomplished by R_C in Figure 98. The parallel inductor cancels the capacitive component of the filter input impedance. Increasing the value of R_C will increase the gain of the amplifier but will also increase TTE. The output impedance match is accomplished by R_3 . Here, a higher value for R_3 results in a lower TTE, but as stated before, R_C should equal R_3 for minimum power loss. The values of R_C and R_3 must be determined by compromising between gain and TTE suppression. Because the signal is amplified to high levels, intermodulation distortion becomes a concern. A common

way to prevent this is to insert a negative feedback resistor on the emitter.

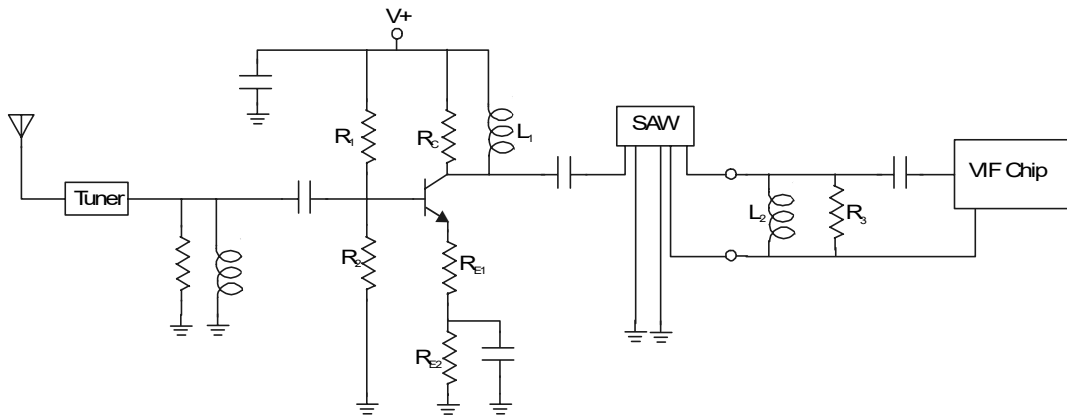

Figure 98: Pre-amplifier Matching Circuit

The preamplifier system is suited for high impedance SAW filters. For low impedance filters, the resistor values would have to be small to suppress TTE. If R_C is too small, then the collector current is limited by the maximum collector dissipation of the transistor and the gain suffers. In order to use a low impedance filter an impedance conversion circuit is required (Figure 99). The capacitance of the SAW filter corresponds to C_2 in the conversion circuit, the coil corresponds to L_1 , and capacitors added in place of the circles in Figure 98 correspond to C_1 . The transformation ratio is given by $C_1 : (C_1 + C_2)$ and the impedance ratio is given by $C_1^2 : (C_1 + C_2)^2$. An arbitrary impedance transformation can be set by picking a convenient value of C_1 . The impedance at the input of the filter can be increased by stepping down and at the output the impedance can be increased by stepping up. In this way, a low impedance filter can be used with the same peripheral circuit.

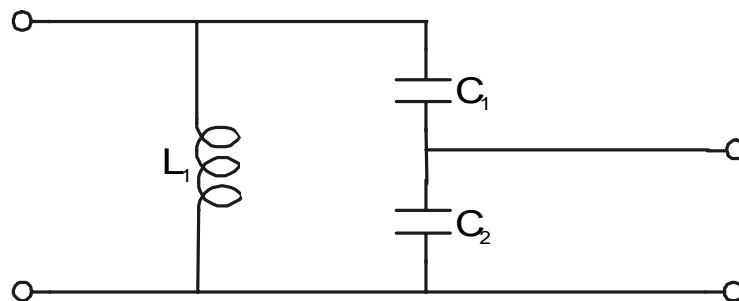

Figure 99: Impedance Conversion Circuit

The system that places the amplifier after the filter is called a postamplifier system. Figure 100 shows an example of a postamplifier system. The input impedance will have a value around 50Ω to 100Ω while the output of the tuner is nominally 75Ω . Since the input of the SAW is not 75Ω the output circuit of the tuner can be affected. If the impedance is higher than 75Ω , then the Q of the IF output circuit becomes high and the bandwidth becomes narrower. To prevent this, a Q damping resistor should be placed in parallel with the input terminals of the SAW filter. Because of the low signal level after the filter there could be deterioration of the noise figure. For this reason, it is desirable to use a high gain tuner. In order to prevent deterioration of the Signal to Noise ratio the tuner should be able to handle a high signal level

before AGC begins to operate.

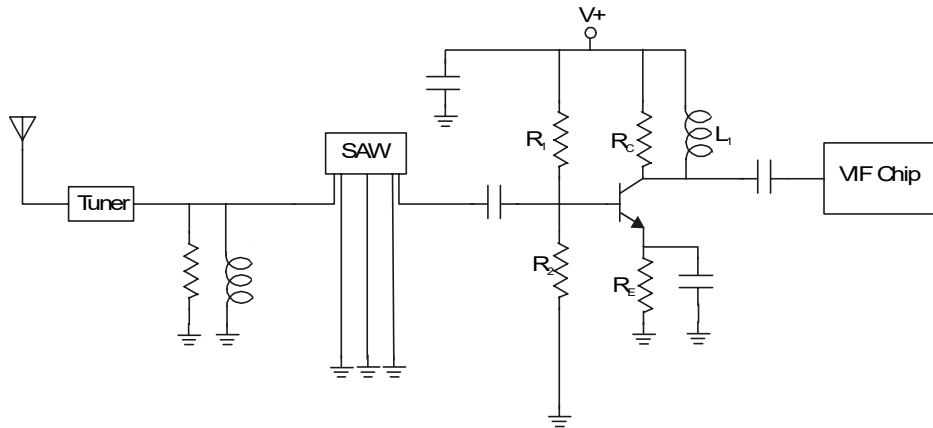

Figure 100: Post-amplifier Matching Circuit For Low Impedance

The postamplifier design is best used with low impedance filters because the filter termination is limited to a low impedance. To use high impedance filters with this design a tuning coil must be placed in series with the filter input as shown in Figure 101. This will allow a close match at the input that will reduce loss. The large mismatch at the output will cause a high loss that will suppress TTE. In this way, a high impedance filter can be used with the same peripheral circuit.

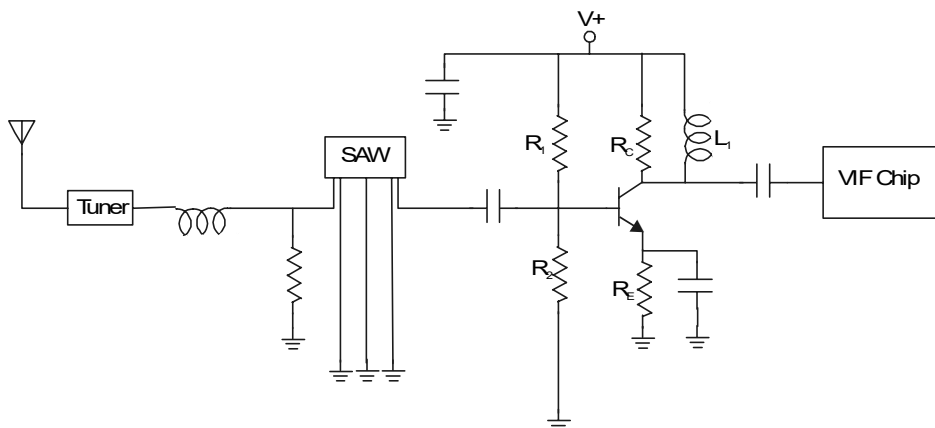

Figure 101: Post-amplifier Matching Circuit For High Impedance

If the gain of the VIF chip can be increased then the amplifier becomes unnecessary. The tuner becomes the signal source for the SAW with a fixed impedance of 75Ω and the VIF chip becomes the load with an impedance between $1k\Omega$ and $3k\Omega$. Since the source and load have fixed impedances it is necessary to include matching circuits in either the input or the output. For a high impedance filter, a parallel coil can practically match the output of the filter to the input of the chip, or a series coil matches the input of the filter to the output of the tuner as described previously. In the case of a low impedance, the input of the filter is matched to the output of the tuner by a parallel coil, or the output of the filter is matched to the input of the chip by the transformation circuit described above. Both circuits can attain an insertion loss of approximately 10 - 18dB making the amplifier unnecessary. Figure 102 shows diagrams for both types of filter.

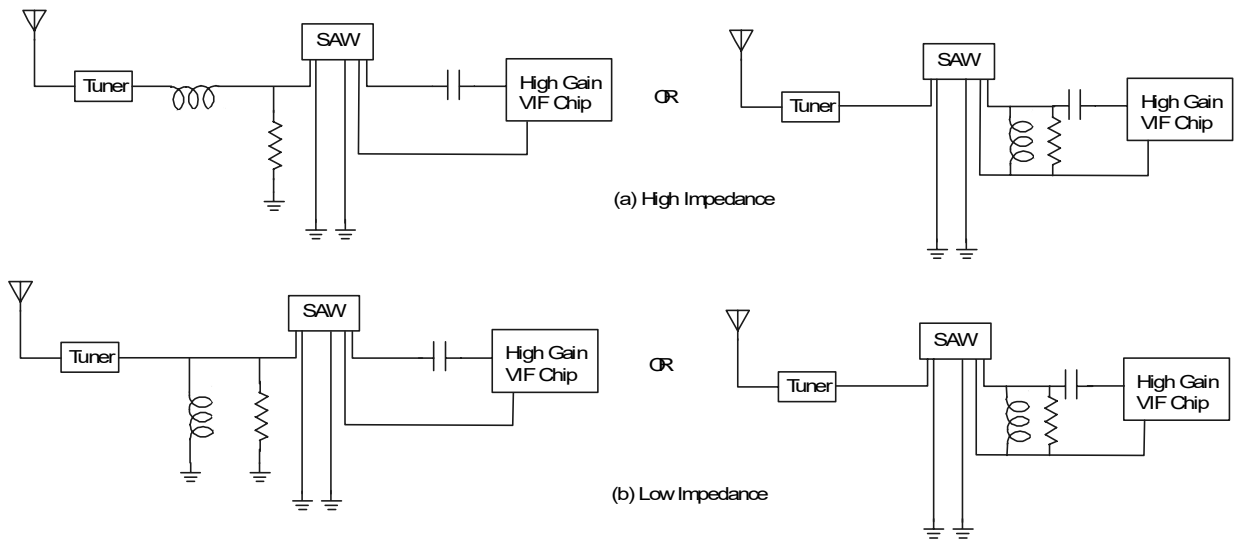

Figure 102: No Amplifier Matching Circuits

Murata offers a characterization service, free of charge, which will provide a matching circuit for the SAW filter. The customer must provide samples of the IC they intend to use and Murata will provide the output circuit and frequency correlation data. It is recommended that the customer provide a sample of their PC board so that both impedance matching and breakthrough suppression can be evaluated. This ensures the best possible performance of the filter.

Parts

Figure 103 shows the basic part numbering structure Murata uses for its SAW filters.

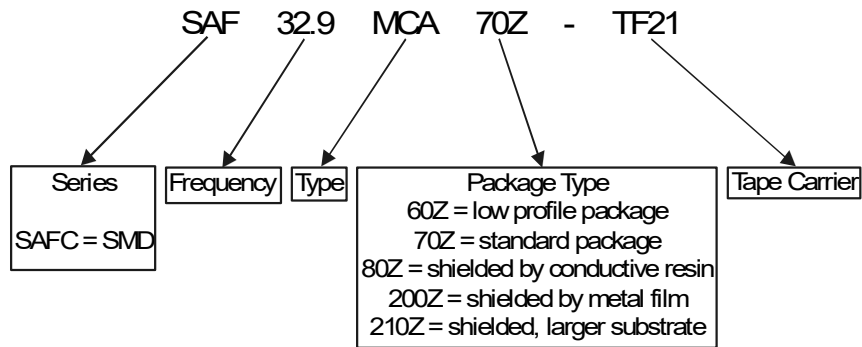

Figure 103: SAW Filter Part Numbering System

The 80Z and 200Z packages can be supplied in ammo-pack packaging. A SAW filter data book, listing the filters and the system each filter applies to is available upon request.

BGS Devices

Introduction

Surface acoustic wave (SAW) devices are used in various consumer products, generally above 30MHz because of device size and cost factors. Murata has recently applied a fundamental technology called BGS that significantly reduces size and cost of certain SAW devices. BGS is a combination of the initials of the three scientists who developed the technology for use on PZT ceramics (Bleustein, Gulyaev, and Shimizu). Use of PZT ceramic was not considered practical for mass production because of a number of material related problems, including a large deviation of PZT material quality and the limited availability of PZT ceramics with both a small temperature coefficient and a large coupling factor. There were also fabrication related problems, but Murata has successfully solved these problems, allowing us to develop several new products. With the BGS technology we are able to make resonators, traps, and filters based on a resonator configuration. BGS filters can replace some SAW filters, but availability of the filters is limited by material.

How Does It Work

The idea behind a SAW resonator is to create a standing wave across the substrate and have a single interdigital transducer (IDT) act as both the receiving and transmitting antenna. Conventional SAW filters and resonators utilize what is called a Rayleigh wave (Figure 104). This consists of a wave that displaces in two dimensions (X and Z in Figure 104). If you imagine a rectangular table, the first part of the wave would be a variation in the thickness of the table (the SV wave). The second part would be compressing the table in the same direction that the wave is traveling (the L wave). This would be like pushing and pulling on the ends of the table. The problem with this kind of wave is that it does not reflect well at the free edge of the substrate. As can be seen in Figure 104, when the SV wave reflects, a spurious P(L) wave component is generated. Likewise, a spurious SV wave is generated when the P(L) wave is reflected. This leads to signal distortion and loss of energy due to the creation of the spurious waves..

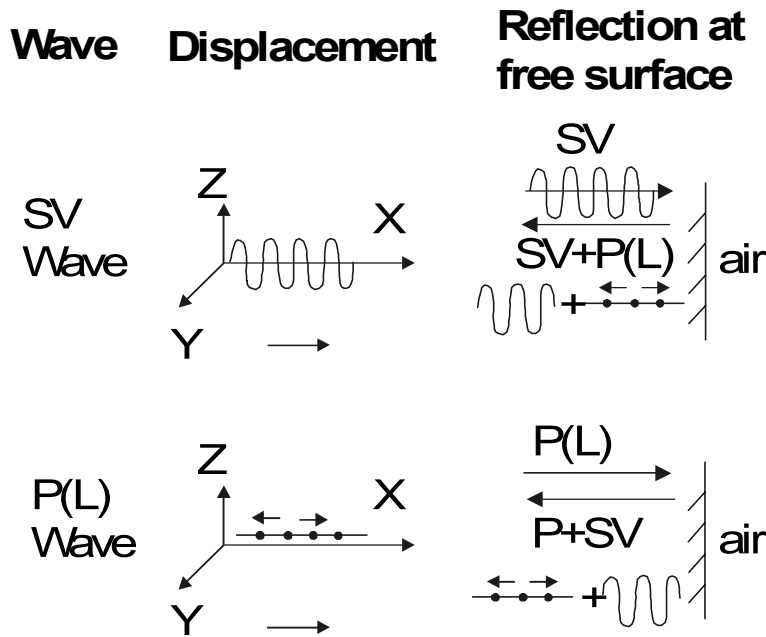

Figure 104: Rayleigh Wave Components

To solve this problem, large reflectors are placed on either end of the substrate to guarantee 100% reflection of the Rayleigh wave and a stable standing wave along the substrate (Figure 105). A very large area of substrate must be

used to accommodate these reflectors. The larger substrate results in a larger part size and an increased cost.

Raleigh wave resonator with reflectors

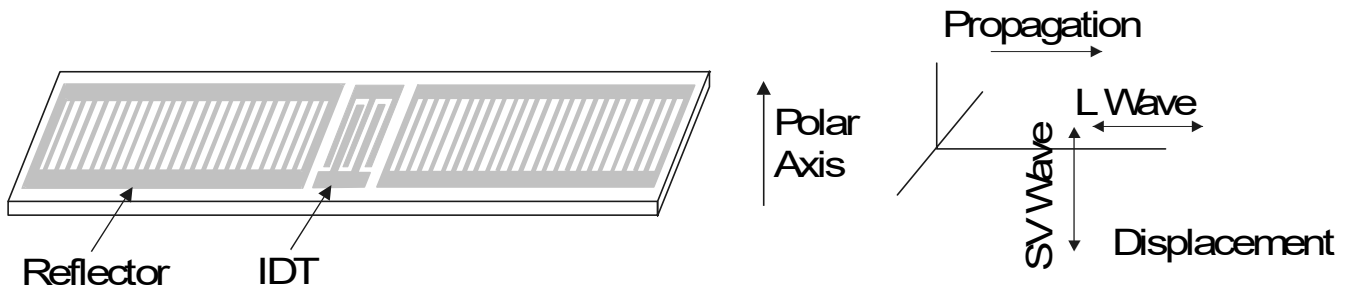

Figure 105: Rayleigh Wave Resonator

The BGS devices use a third kind of wave called the SH wave and do not have the SV or L waves. The SH waves have a displacement parallel to the surface of the substrate, and perpendicular to the direction of propagation. This wave can be simulated by sliding your hand from side to side as you move from one end of the table to the other (Figure 106).

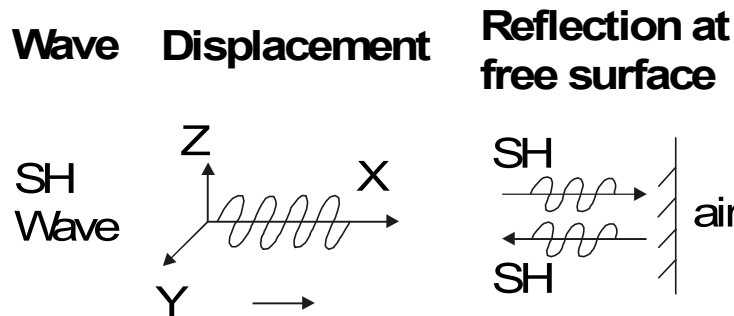

Figure 106: SH Wave Component

The SH wave can achieve 100% reflection at the free edge of the substrate, allowing us to remove the reflectors from the BGS and SH wave devices. This means we can achieve a 50% to 75% reduction in size (3.8 x 3.8 x 1.5mm typical size for BGS devices). The smaller substrate also allows us to realize a cost reduction over conventional SAW devices (Figure 107).

SH wave resonator using edge reflection

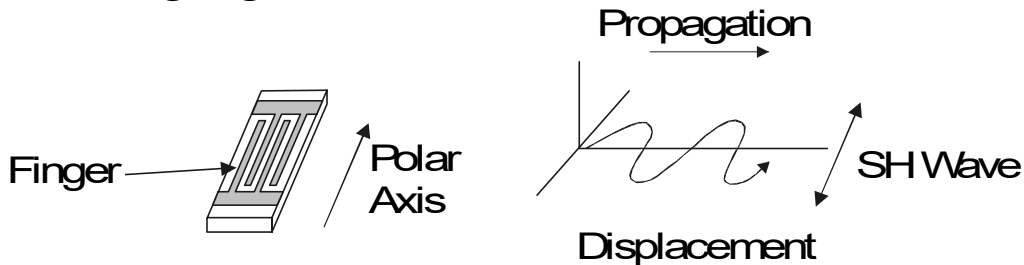

Figure 107: BGS and SH Wave Resonators

Currently Murata is developing this technology on three different substrates; piezoelectric ceramic (PbZrTiO_4 or PZT), Lithium Tantalate (LiTaO_3 or LT), and quartz crystal (X'tal). We refer to the PZT substrate devices as BGS devices and the other two as SH wave devices, though they all work in the same way.

We are able to achieve a wide range of frequencies and bandwidths with these materials. The following table gives a breakdown of the characteristics.

Substrate Material	Center Frequency Range (MHz)	Bandwidth Range (%)	Temperature Variation (ppm/oC)	Impedance Variation (Ω)
PZT	20 - 70	1 - 4	7	50 (No inductor required)
LT	100 - 200	1 - 2	-30	200 - 600 (Inductor required)
X'tal	110 - 300	0.05 - 0.08	1	1k - 1.5k (Inductor required)

Table 13. Characteristics of the BGS and SH Wave Devices

Parts

Murata currently offers BGS VCO resonators as well as traps for television, cable television, and VCR applications. We are developing resonator based BGS filters for 1st IF in cellular applications (GSM and CDMA2000) and actively looking for new markets and applications for this product.

Piezoelectric Sound Components

Introduction

Murata Electronics' piezoelectric sound components (piezo alarms) are designed for applications requiring a highly reliable acoustic alarm or audible tone signal. Their reliability extends from the fact that they are solid state construction so they have very few moving parts. These devices can produce either a single or multi-frequency output depending upon operating requirements. The tone is distinct due to the absence of harmonics, and gives an extremely clear, penetrating sound. Their high acoustic output versus low input power requirements make them ideal for a wide variety of applications, especially products powered by battery. They are used as indicators or alarms that call a person's attention to the product. These buzzers and speakers are used in products such as phones, pagers, smoke detectors, and appliances like microwaves.

How Does It Work

Sound is simply a wave of varying air pressure. These pressure waves cause a thin membrane in the ear to vibrate and the brain interprets these vibrations as sound. A decibel (dB) scale is used to describe the sound pressure level (SPL) or loudness of a sound. An increase of 20 dB means that the SPL increased by ten times. Figure 108 shows the dB scale.



Figure 108: SPL Level Reference

The sound pressure level specification for a buzzer must have three additional pieces of information included. First is the distance from the sound emitting hole that the measurement was taken. The reason for this is that as the sound wave expands outward, it loses strength. The measurement will be louder 10cm from the buzzer hole than it would be 30cm from the buzzer hole. The second piece of information is the frequency at which the buzzer was driven. The buzzer has a resonant frequency that will produce the loudest sound and any other frequency will produce a lower SPL. The last piece of information is the input drive voltage. A higher input voltage will produce a louder sound up to the point at which the material breaks down. Without all of this information an accurate comparison cannot be made between two different buzzers.

The sound source of a piezoelectric sound component is the piezoelectric diaphragm. The piezoelectric diaphragm (bender plate) consists of a piezoelectric ceramic plate, with electrodes on both sides, attached to a metal plate (brass,

stainless steel etc) with conductive adhesive. Figure 109 shows the construction diagram of a piezoelectric diaphragm.

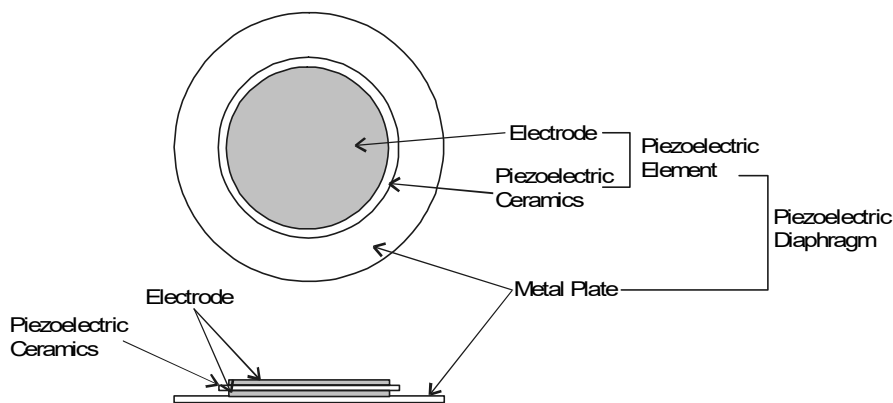

Figure 109: Piezoelectric Diaphragm

The sound is created from the movement of the metal plate. Applying a D.C. voltage between electrodes of the piezoelectric diaphragm causes mechanical distortion due to the piezoelectric effect. The distortion of the piezoelectric ceramic plate expands in the radial direction causing the metal plate to bend shown in Figure 110(a). Reversing the polarity of the D.C. voltage cause the ceramic plate to shrink, bending the metal plate in the opposite direction, shown in Figure 110(b). When an A.C. voltage is applied across the electrodes, the diaphragm alternates bending in the two directions. The repeated bending motion produces sound waves in the air.

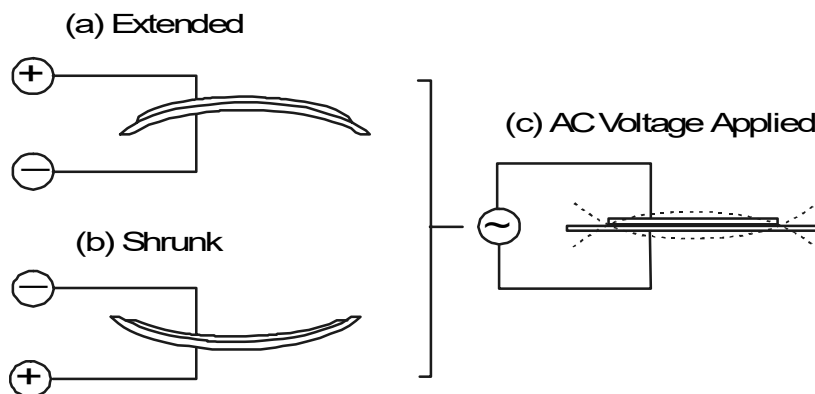

Figure 110: Diaphragm Operation

Note: Murata does not recommend using a drive signal with a DC bias because it could depolarize the ceramic and limit maximum SPL performance.

Typically, the piezoelectric diaphragm alone does not produce a high SPL. It is necessary to mount the diaphragm in a resonant cavity designed to enhance the SPL for a specific frequency.

Design Of The Resonating Cavity

The piezoelectric element alone can not produce a high sound pressure level (SPL). This is because the acoustical impedance of the element does not match that of any open air loading. Therefore a resonating cavity must be built to match the acoustical impedance of the element and the encased air. There are three methods in mounting the piezo diaphragm to a resonating cavity. The method of mounting the diaphragm will effect the sound output. The three methods of mounting are as follows:

- Node Support

The diaphragm is mounted at a node, a circumference where no vibration takes place. This method causes the least mechanical suppression of vibration and thus provides the highest SPL and the most stable oscillation frequency of the three methods. Node support enhances only a narrow range of frequencies but does so very well. The frequency of the sound output will equal the piezo diaphragm resonant frequency.

- Edge Support

The diaphragm is mounted at the outer edge of the disk causing the entire disk to vibrate. This method suppresses the fundamental frequency by moving the node but provides a possibility of a wide frequency response. The frequency output will be approximately half of the piezo diaphragm's resonant frequency.

- Center Support

The diaphragm is mounted at the center of the disk causing the outer edge to vibrate. This method provides the lowest SPL since the main vibration area is forcefully supported. This method is not useful due to design difficulties.

Figure 111 illustrates the different support methods.

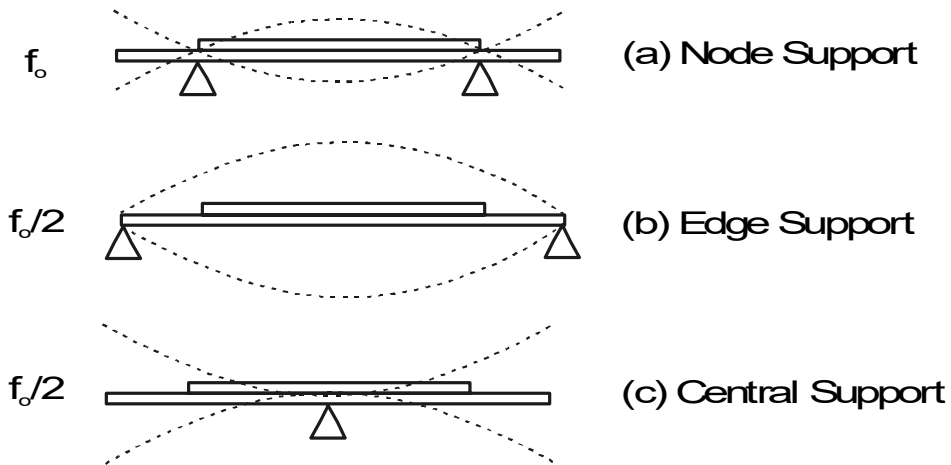

Figure 111: Mounting Methods

The resonant frequency of the cavity is obtained from Helmholtz's Formula.

$$f_0 = \frac{c}{2\pi} \sqrt{\frac{4a^2}{d^2h(t + ka)}}$$

f_0 = Resonant frequency of cavity (Hz)

c = sound velocity 34.4x10³ cm/sec @ 24°C

a = radius of sound emitting hole (cm)

d = diameter of support

t = thickness of cavity

k = constant $\cong 1.3$

The buzzer diagrams in Figure 112 show what is being specified by the equation variable “a”, “d”, “t”, and “h”.

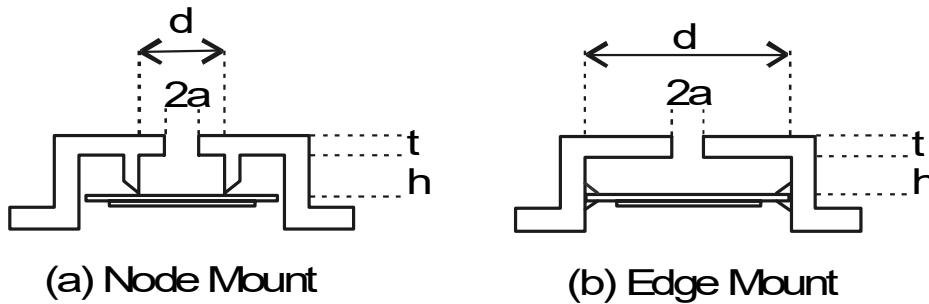

Figure 112: Cavity Measurements For Helmholtz's Formula

By designing the diaphragm and the cavity to have the same resonant frequency, the SPL is maximized and specific bandwidths can be provided.

Drive Procedure

There are two ways to drive piezoelectric sound components: External-Drive and Self-Drive

- External Drive

This drive method is typically used with edge mounted devices and uses an external oscillating circuit to produce sound. In this way the device can act as a speaker and produce frequencies over a specific bandwidth. This type of drive method is used when multiple tones are desired. Externally driven devices have found extensive use in watches, calculators, game machines, as well as appliances like microwave ovens, washing machines, and TVs.

- Self Drive

This method is used with node mounted devices. The diaphragm has a feedback tab on one of the electrodes that is used in closed loop Hartley types of oscillation circuits. When the circuit is closed to the resonant frequency, the conditions for oscillation are met and the diaphragm produces a single high-pressure tone. This type of drive procedure will produce only one tone but will have the highest SPL possible from the buzzer.

Figure 113 illustrates the two drive types.

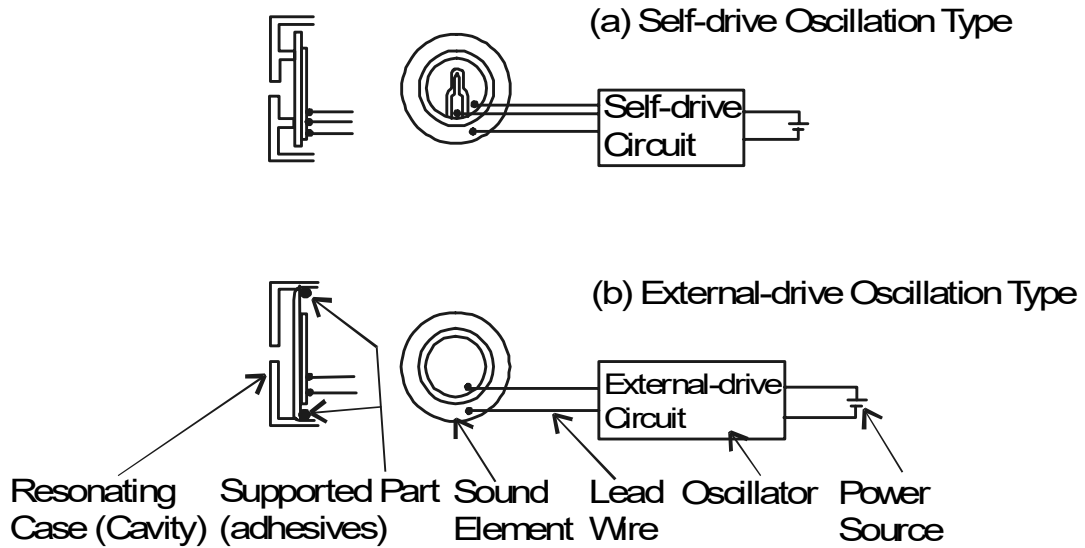

Figure 113: Two Drive Oscillation Types

Figure 114 gives a simple example of an external drive circuit.

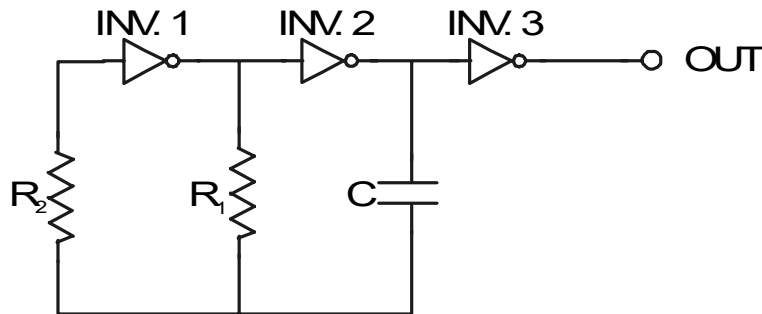

Figure 114: Example of External Drive Circuit

INV.1 and INV. 2 Make an astable oscillator while INV. 3 acts as a buffer and a waveform shaper, providing a sharp square wave output. The equation for the circuit is:

$$f_{osc} = \frac{1}{2.2R_1C}$$

$$R_2 \cong 10R_1$$

Resistor values can range from about 3kΩ to about 10MΩ. Capacitor values can range from 50pF up, though below 1000pF the frequency will be somewhat lower than predicted by the equation. The input resistor, R₂, is normally made 10 times the timing resistor, R₁, to minimize the output curving effect of the protection diodes in the inverter.

By adding a fourth inverter between the leads of the external drive buzzer, a push-pull circuit is made (Figure 115). If one terminal of the buzzer were connected to ground and the other to the output of the inverter, the buzzer would see a voltage only on one terminal. The element would only deflect in one direction. By adding the fourth inverter, a voltage can be applied to both pins and the element will deflect in both directions. This doubles the voltage across the buzzer and increases the SPL.

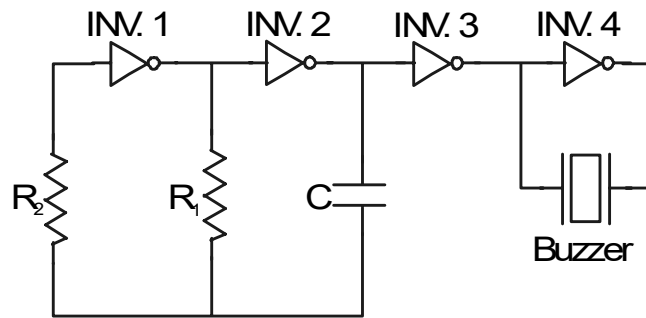

Figure 115: Inverter Push-Pull Circuit

For drive voltages greater than what can be provided by an IC, a transistor circuit can be made (Figure 116).

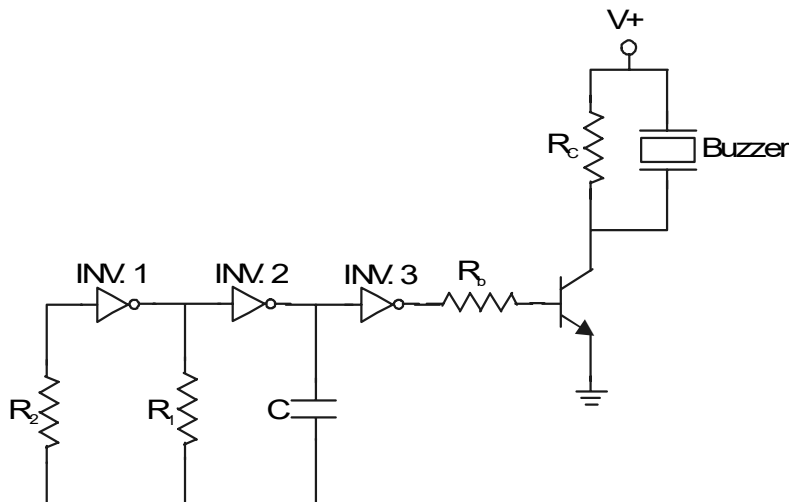

Figure 116: External Drive Circuit Using A Transistor

R_b and R_c are both generally about 1kΩ. By using a higher voltage, the diaphragm deflects more and a higher SPL can be achieved. A transistor push-pull circuit can also be made to further increase SPL (Figure 117). The transistors are biased as switches and a square wave is applied to the bases 180° out of phase. This will have the same effect as the inverter in the previous circuit, causing the element to deflect in both directions and increasing the SPL, but it can han-

die voltages that would destroy an IC.

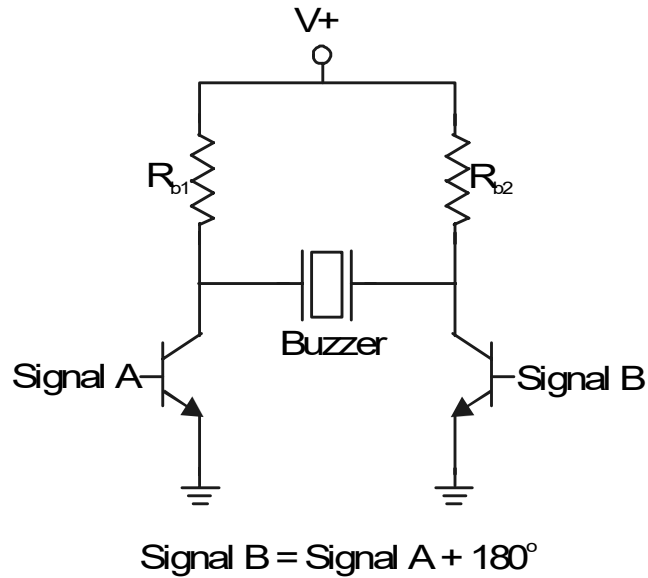

Figure 117: External Drive Push-Pull Circuit

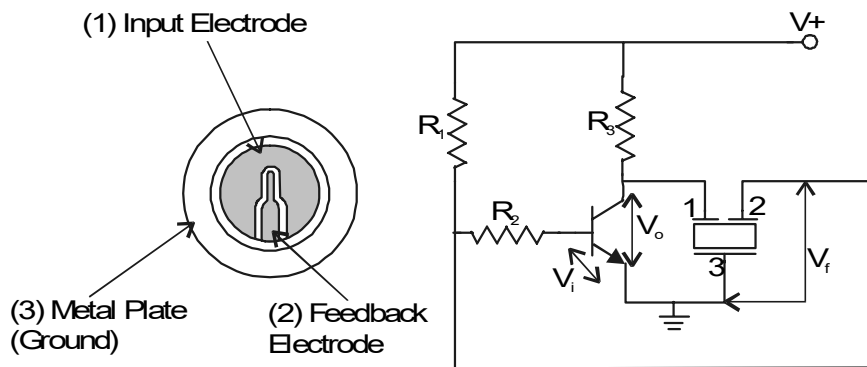

Figure 118: Example of Self-Drive Circuit

For the self drive circuit in Figure 118, R_1 is chosen so that the transistor bias point, V_{CE} , is half of the supply voltage. The following equation is used for the other resistors:

$$\frac{V_F}{V_O} = \frac{R_2 + h_{ie}}{h_{fe} \times R_3}$$

Where:

h_{ie} = input impedance of transistor

h_{fe} = current amplification

Booster Coils

It is possible to increase the SPL of a buzzer by about 3 - 6dB by replacing RC in Figure 116 and R_3 in Figure 118 with an inductor. The higher SPL is a result of the resonance between the inductor and the element, which is capacitive. The value of the inductor is determined by the following equation at the frequency of operation:

$$f_{osc} = \frac{1}{2\pi\sqrt{LC}}$$

Where:

L = value of the inductor

C = capacitance of the piezoelectric element

Generally, a suitable value is between 30mH and 60mH. When the booster coil is used with the self drive circuit in Figure 118, the other resistor values will probably need to be changed to ensure stable oscillation.

Circuit Design Considerations

- Driving Waveform

The piezo elements may be driven with sinusoidal, pulsed, or square waves. A sine wave will cause the device to operate at a frequency lower than the resonant frequency with a lower SPL. This is due to the loss of energy through the lag time between peak deflections. A square wave will produce higher sound levels because of the near instantaneous rise and fall time. Clipping of sinusoidal waveforms can result in frequency instability and pulse and square waves will cause an increase in harmonic levels. A capacitor in parallel with the diaphragm can reduce the harmonics.

- DC Precautions

Subjecting the ceramic elements to direct current can cause them to depolarize and stop working. For this reason, it is best to drive the buzzers with an A.C. signal that has a zero D.C. bias. Blocking capacitors are recommended to prevent a bias.

- High Voltage Precautions

Voltages higher than those recommended can cause permanent damage to the ceramic even if applied for short durations. Significantly higher sound pressure levels will not be achieved by higher voltages before permanent damage is caused.

- Shock

Mechanical impact on piezoelectric devices can generate high voltages that can seriously damage drive circuitry, therefore, diode protection is recommended.

- SPL Control

It is not recommended to place a resistor in series with the power source since this may cause abnormal oscillation. If a resistor is essential in order to adjust the sound pressure then place a capacitor (about 1 μ F) in parallel with the buzzer (Figure 119).

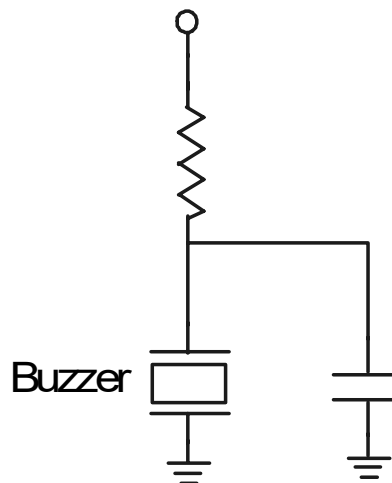

Figure 119: Capacitor Bypass of Buzzer

- Washing

Murata provides water-resistant components but will not guarantee that no water will penetrate the device. If water should get inside the component then it could cause silver migration between the terminals. This could short out the device and cause it to stop functioning. For this reason, Murata recommends that the parts not be washed. Murata can supply some components with tape covering the sound-emitting hole. This will make the component more water resistant for washing.

- Soldering

A lead wire is required to apply voltage to the piezoelectric diaphragm. This wire should be as fine as possible because it acts as a load on the diaphragm, which restricts oscillation. When using a soldering iron, the optimum temperature for soldering the lead wire to a metal plate is 300°C for a few seconds. The optimum temperature for soldering the lead wire to the ceramic silver electrode is 300°C for 0.5 second or less.

Parts

Table 14 lists the series of buzzers offered by Murata.

Buzzer Series	Description
PKMC	Surface mount external drive buzzer
PKM	Self or external drive with no internal circuitry Requires AC Drive Signal.
PKB	Internal circuitry included. Requires DC Voltage
VSB	Speaker Elements capable of reproducing speech
PKD	Electroacoustic transducer for telephones
7BB, 7NB, 7SB	Buzzer elements

Table 14. Buzzer Series Description

Figure 120 shows an example of the general part numbering system used by Murata.

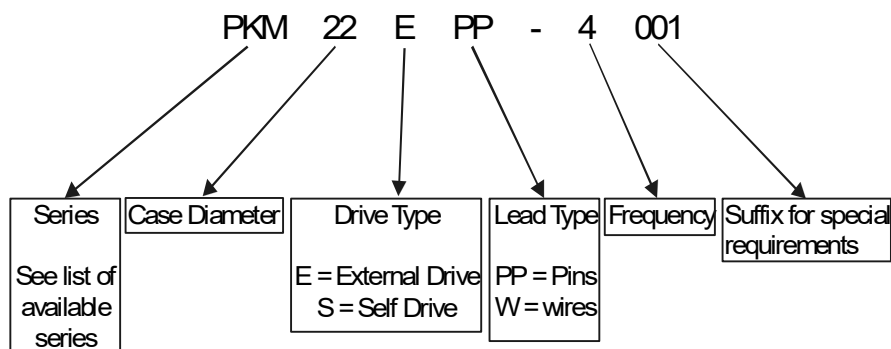

Figure 120: Buzzer Part Number System

Parts that are on tape (for automatic insertion) will have a -TF01 suffix. Currently this is only available with the PKM13EPY-4000-TF01. Parts that come with tape over the sound-emitting hole will also have a suffix. PKM series parts will have an "S" suffix. PKB series parts will have a "W" suffix. The PKB series also has epoxy around the base to help prevent water from getting into the drive circuitry. Currently only the following buzzers are available sealed for washing:

- PKM22EPP-4001S
- PKM17EPP-4001S
- PKM25SP-3701S
- PKB24SPC-3601W
- PKB30SPC-2001W
- PKB30SPC-3001W

Table 15 lists the buzzers offered by Murata.

Part Number	Oscillating Frequency (kHz)	Case Diameter (mm)	Case Thickness (mm)	Pins / Wires	Pin Spacing (mm)	Available in Tape	External / Self Drive	Flange Center (mm)
PKMC16E-4000-TY	4	16	2.7	P	16	N	E	----
PKM22EPP-4001	4	22	7	P	10	N	E	----
PKM22EP-2001	2	22	11	P	22	N	E	----
PKM35-4AO	4	16.8	4	W	----	N	E	----
PKM17EW-2001	2	16.8	7	W	----	N	E	----
PKM13EPY-4002	4	12.6	6.9	P	5	Y	E	----
PKM17EPP-4001	4	17	7	P	10	N	E	----
PKM11-4AO	4.096	24	4.5	W	----	N	E	29
PKM25-6AO	6.8	25	7	P	4 / 8.5	N	S	----
PKM25SP-3701	3.7	25	7	P	4 / 8.5	N	S	----
PKM24SP-3805	3.8	24	11	P	ANGLED	N	S	----
PKM11-6AO	6.5	24	4.5	W	----	N	S	29
PKM29-3AO	3.4	39	20	P	8 / 10.5	N	S	----
PKM37-2AO	2	30	10	P	ANGLED	N	S	----
PKB24SPC-3601	3.6	24	9.7	P	15	N	E	----
PKB30SPC-2001	2	30.3	17.7	P	15	N	E	----
PKB30SPC-3001	2.7	30.3	17.7	P	15	N	E	----
PKB5-3AO	2.8	42	14.5	W	----	N	E	50
PKB6-5AO	4.7	34	13.5	W	----	N	E	45
VSB35EW-0701B	0.6 - 20	35	1.7	----	----	----	E	----
VSB50EW-O3O1B	0.25 - 20	50	2.5	----	----	----	E	----
VSB41D25-07ARO	0.5 - 20	50	2	----	----	----	E	----
PKD17EW-01R	0.3 - 3.4	17	2	----	----	----	E	----
PKD22EW-01R	0.3 - 3.4	21.5	2	----	----	----	E	----
PKM33EP-1001	1	33	7.5	P	ANGLED	N	E	----
PKM34EW-1101C	1.1	34.5	9	W		N	E	40
PKM44EW-1001C	1	61	14	W		N	E	52
PKM44EP-0901	1	40.5	13	P	45	N	E	----
PKM17EPT-4001	4	20	7.5	P	10	N	E	----
PKM22EPT-2001	2	26.5	7	P	12.5	N	E	----
PKM30SPT-2001	2	33.25	7.7	P	7.5 / 12.5	N	S	----
7BB-20-6C	6.3	20	0.42	W	----	N	S	----
7BB-27-4C	4.6	27	0.54	W	----	N	S	----
7BB-35-3C	2.8	35	0.53	W	----	N	S	----
7BB-41-2C	2.2	41	0.63	W	----	N	S	----
7SB-34R7-3C	3.3	34.7	0.5	W	----	N	S	----
7SB-34R7-3C2	3.1	37.4	0.5	W	----	N	S	----
7BB-20-6CAO	6.3	20	0.42	W	----	N	S	----
7BB-27-4CAO	4.6	27	0.54	W	----	N	S	----
7BB-35-3CAO	2.8	35	0.53	W	----	N	S	----
7BB-41-2CAO	2.2	41	0.53	W	----	N	S	----
7BB-12-9	9	12	0.22	W	----	N	E	----
7BB-15-6	6	15	0.22	W	----	N	E	----
7BB-20-6	6.3	20	0.42	W	----	N	E	----

Table 15. Murta Buzzer Products

7BB-27-4	4.6	27	0.54	W	----	N	E	----
7BB-35-3	2.8	35	0.53	W	----	N	E	----
7BB-41-2	2.2	41	0.63	W	----	N	E	----
7SB-20-7	7.2	20	0.42	W	----	N	E	----
7SB-21-7	6.6	21	0.36	W	----	N	E	----
7SB-27-5	4.8	27	0.47	W	----	N	E	----
7BB-20-6AO	6.3	20	0.42	W	----	N	E	----
7BB-27-4AO	4.6	27	0.54	W	----	N	E	----
7BB-35-3AO	2.8	35	0.54	W	----	N	E	----
7BB-41-2A0	2.2	41	0.64	W	----	N	E	----
7NB-31R2-19R7DM-1	1.3	31.2	0.27	W	----	N	E	----
7NB-41-25DM-1	0.85	41	0.21	W	----	N	E	----

Table 15. Murta Buzzer Products

Appendix I

Equivalent Circuit Values

The following equivalent circuit values are for the circuit model in Figure 121.

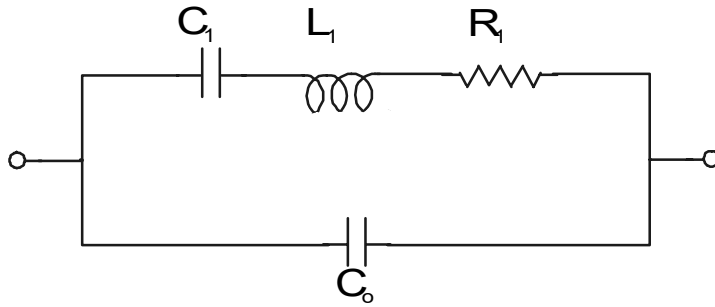

Figure 121: Equivalent Circuit Model For Ceramic Resonator

Ceralok Type	Fr (kHz)	Fa (kHz)	R1 (Ω)	L1 (mH)	C1(pF)	Co (pF)
CSB400P	388.5	402.4	6.2	6.704	25.046	344.364
CSB455E	443.9	457.3	10.1	7.68	16.74	272.76
CSB500E	487.2	503.2	8.5	7.163	14.907	222.824
CSB600P	586.5	604.2	11.8	6.186	11.912	194.269
CSB700J	682	706.5	11.1	5.387	10.068	146.862
CSB1000J	978.5	1013.3	13.7	4.441	5.958	82.481
CSB1200J	1179.6	1220.8	45.4	4.533	4.018	56.489
CSB456F11	436.6	457.9	11.4	4.163	31.924	320.378
CSB456F14	435.9	457.4	11	3.947	33.785	333.517
CSB500F2	506.1	549.8	8.5	1.321	74.896	415.585
CSB500F9	489	543.9	27.9	0.909	116.569	490.913
CSB503F2	509.5	554	8.5	1.246	78.33	429.017
CSB912JF103	851.8	920.7	23.1	1.344	25.971	154.401
CSB912JF104	853	925.3	20.7	1.247	27.909	157.875
CSKCC455E	451.3	459.5	144.5	46.912	2.651	72.895
CSA2.00MG	1922.9	2046.7	18.3	1.397	4.908	36.942
CSA2.50MG	2391.4	2575	17.3	0.755	5.867	36.786
CSA3.00MG	2856.1	3083.5	12.9	0.439	7.073	42.741
CSA3.58MG	3424.5	3670.2	6.7	0.361	5.993	40.324
CSA4.00MG	3812.8	4118.6	6.8	0.284	6.125	36.719
CSA4.19MG	4008	4310.4	5.1	0.266	5.948	37.978
CSA5.00MG	4801.3	5133.6	4.9	0.217	5.046	35.692
CSA6.00MG	5750.8	6176.7	5.6	0.154	4.987	32.469
CSTS0400MG03	3372.5	3722.5	8.6	0.474	4.694	21.5
CSTS0358MG03	3818	4138	10.8	0.534	3.254	18.63
CSTS0500MG03	4757.5	5190	8.2	0.34	3.288	17.296
CSTS0600MG03	5760	6305	7.5	0.227	3.367	16.991
CSTS0800MG03	7667.5	8282.5	8.5	0.137	3.147	18.863

Table 16. Resonator Equivalent Circuit Values

CSTC2.00MG	1950.6	2098	94.9	4.651	1.431	9.124
CSTC2.50MG	2433.9	2638	75	2.095	2.021	11.612
CSTC3.00MG	2877.5	3098.9	10	0.779	3.931	24.598
CSTCC3.58MG	3488.7	3723.2	38	2.072	1.014	7.228
CSTCC4.00MG	3796	4166	8.6	0.476	3.689	18.045
CSTCC5.00MG	4746.8	5100	13.4	0.358	3.144	20.37
CSTCC6.00MG	5725	6250	9.9	0.232	3.326	17.337
CSTCC8.00MG	7585	8340	6.9	0.111	3.969	18.992
CSTCC10.0MG	9530	10465	6.3	0.081	3.459	16.802
CSA8.00MTZ	7650.9	8247.6	4.5	0.068	6.419	39.6
CSA10.0MTZ	9628.7	10357.2	4.6	0.054	5.074	32.313
CSA11.0MTZ	10586.9	11403.8	5.3	0.043	5.245	32.784
CSA12.0MTZ	11511.2	12348.5	5.8	0.034	5.603	67.196
CSACV10.0MTJ	9539.3	10102.9	6.3	0.061	4.565	37.515
CSACV12.0MTJ	11408.1	12107.3	5.3	0.035	5.499	43.527
CSA16.00MXZ040	15966.7	16067.4	14.2	0.564	0.176	13.922
CSA20.00MXZ040	19929.6	20055.3	13.3	0.493	0.129	10.217
CSA27.00MXZ040	26930.8	27087.1	14.8	0.407	0.086	7.365
CSA30.00MXZ040	29893.1	30060.8	12.7	0.31	0.091	8.163
CSA33.86MXZ040	33766.3	33921.1	15.1	0.26	0.085	9.273
CSA40.00MXZ040	39932.2	40090.8	15.1	0.216	0.073	9.314
CSA50.00MXZ040	49918.6	50102.6	15.8	0.143	0.071	9.572
CSA60.00MXZ040	59973	60190	26.7	0.128	0.055	7.834
CSACV16.00MXJ040	15934.1	16030.1	14.4	0.651	0.153	12.685
CSACV20.00MXJ040	19957.8	20073.4	13.5	0.471	0.135	11.636
CSACV27.00MXJ040	26916.8	27066.2	13.6	0.315	0.111	9.967
CSACV30.00MXJ040	29912.3	30069.8	12.6	0.272	0.104	9.867
CSACV33.86MXJ040	33779.2	33952.9	11.7	0.213	0.104	10.126
CSACV40.00MXJ040	39917.8	40112.5	14.3	0.217	0.073	7.548
CSACV50.00MXJ040	49903.4	50127	15.1	0.169	0.059	6.72
CSACV60.00MXJ040	59913	60216.4	23	0.164	0.043	4.315
CSACW1600MX03	15962.8	16026.7	86.4	1.069	0.093	16.876
CSACW2000MX03	19955.2	20042.3	32.7	0.629	0.101	11.557
CSACW2700MX03	26952.3	27026.8	19	0.364	0.096	17.327
CSACW3386MX03	33822.6	33914.2	16.3	0.253	0.088	16.131
CSACW4000MX03	39913.5	40037.1	13.9	0.217	0.072	11.875
CSACW5000MX03	49949.6	50083.1	16.4	0.177	0.056	10.843

Table 16. Resonator Equivalent Circuit Values

Appendix 2

Resonator Test Circuit Values

The following charts list the test circuit values for Murata's resonators. The values shaded gray are standard parts that are currently available. Other values of built-in load capacitors are only available if recommended by an IC characterization.

Series	Frequency Range	CL (pf)				
		15	30	47	100	
CSAC-MGC(A) CSAC-MGCM(A)	1.80 to 6.00 MHz	PN Suffix		x00		x40
		Sort IC		CD4069UBE		TC74HCU04
		VDD (V)		5		5
		Rf (ohm)		1M		1M
		Rd (ohm)		0		680
CSTC-MGA	2.00 to 3.49MHz	PN Suffix		x00		
		Sort IC		CD4069UBE		
		VDD (V)		5		
		Rf (ohm)		1M		
		Rd (ohm)		0		
CSTCC-MG(A)	2.00 to 10.0 MHz	PN Suffix	x00		xH6	
		Sort IC	CD4069UBE		TC74HCU04	
		VDD (V)	5		5	
		Rf (ohm)	1M		1M	
		Rd (ohm)	0		680	

Series	Frequency Range	CL (pf)			
		22	30	100	
CSACV-MTJ	8.00 to 13.00 MHz	PN Suffix		x00	x40
		Sort IC		CD4069UBE	TC74HCU04
		VDD (V)		12	5
		Rf (ohm)		1M	1M
		Rd (ohm)		0	220
CSTCV-MTJ	(8.00 to 10.00 MHz) 10.01 to 13.00 MHz	PN Suffix	xC4		
		Sort IC	TC40H004P		
		VDD (V)	5		
		Rf (ohm)	1M		
		Rd (ohm)	0		
CSACS-MT(A)	6.01 to 13.00MHz	PN Suffix		x00	x40
		Sort IC		CD4069UBE	TC74HCU04
		VDD (V)		12	5
		Rf (ohm)		1M	1M
		Rd (ohm)		0	220
CSTCS-MT(A)	6.01 to 13.00MHz	PN Suffix		x00	
		Sort IC		CD4069UBE	
		VDD (V)		12	
		Rf (ohm)		1M	
		Rd (ohm)		0	

Series	Frequency Range	CL (pf)	5	15	22	30
CSACV-MXJ CSTCV-MXJ	13.50 to 15.99 MHz	PN Suffix	xH1	xH3	xH4	x40
		Sort IC	TC74HCU04	TC74HCU04	TC74HCU04	TC74HCU04
		VDD (V)	3	3	3	5
		Rf (ohm)	1M	1M	1M	1M
		Rd (ohm)	100	0	0	0
	16.00 to 17.99 MHz	PN Suffix	xC1	xC3	xC4	x40
		Sort IC	TC40H004P	TC40H004P	TC40H004P	TC74HCU04
		VDD (V)	5	5	5	5
		Rf (ohm)	1M	1M	1M	1M
		Rd (ohm)	0	0	0	0
	18.00 to 19.99 MHz	PN Suffix	xC1	xH3	xH4	x40
		Sort IC	TC40H004P	TC74HCU04	TC74HCU04	TC74HCU04
		VDD (V)	5	5	5	5
		Rf (ohm)	1M	1M	1M	1M
		Rd (ohm)	0	100	100	0
	20.00 to 25.99 MHz	PN Suffix	xH1	x40	xH4	
		Sort IC	TC74HCU04	TC74HCU04	TC74HCU04	
		VDD (V)	5	5	5	
		Rf (ohm)	1M	1M	4.7k	
		Rd (ohm)	100	0	0	
26.00 to 70.00 MHz	PN Suffix	x40	xH3	xH4		
	Sort IC	TC74HCU04	TC74HCU04	TC74HCU04		
	VDD (V)	5	5	5		
	Rf (ohm)	1M	10k	4.7k		
	Rd (ohm)	0	0	0		
CSACV-MXA-Q CSTCV-MXA-Q	14.74 to 17.99 MHz	PN Suffix	xH1	xH3	xH4	x40
		Sort IC	TC74HCU04	TC74HCU04	TC74HCU04	TC74HCU04
		VDD (V)	3	3	3	5
		Rf (ohm)	1M	1M	1M	1M
		Rd (ohm)	470	220	150	0
	18.00 to 19.99 MHz	PN Suffix	xH1	xH3	xH4	x40
		Sort IC	TC74HCU04	TC74HCU04	TC74HCU04	TC74HCU04
		VDD (V)	5	5	5	5
		Rf (ohm)	1M	1M	1M	1M
		Rd (ohm)	0	100	100	0
	20.00 to 25.99 MHz	PN Suffix	xH1	x40	xH4	
		Sort IC	TC74HCU04	TC74HCU04	TC74HCU04	
		VDD (V)	5	5	5	
		Rf (ohm)	1M	1M	4.7k	
		Rd (ohm)	100	0	0	
	26.00 to 70.00 MHz	PN Suffix	x40	xH3	xH4	
		Sort IC	TC74HCU04	TC74HCU04	TC74HCU04	
		VDD (V)	5	5	5	
		Rf (ohm)	1M	10k	4.7k	
		Rd (ohm)	0	0	0	

Series	Frequency Range	CL (pf)		
		5	15	
CSACW-MX CSTCW-MX	16.00 to 24.99 MHz	PN Suffix	x1	x3
		Sort IC	TC74HCU04	TC74HCU04
		VDD (V)	3	5
		Rf (ohm)	33k	1M
		Rd (ohm)	220	0
	25.00 to 39.99 MHz	PN Suffix	x1	x3
		Sort IC	TC74HCU04	TC74HCU04
		VDD (V)	5	5
		Rf (ohm)	1M	22k
		Rd (ohm)	0	0
	40.00 to 70.00 MHz	PN Suffix	x1	x3
		Sort IC	TC74HCU04	TC74HCU04
		VDD (V)	5	5
		Rf (ohm)	1M	4.7k
		Rd (ohm)	0	0

Series	Frequency Range	CL (pf)				
		15	30	47	100	
CSA-MG(A) CST-MG(A) CST-MGW(A)	1.80 to 6.30 MHz	PN Suffix		x00		x40
		Sort IC		CD4069UBE		TC74HCU04
		VDD (V)		5		5
		Rf (ohm)		1M		1M
		Rd (ohm)		0		680
CSTS-MG(A)	3.40 to 10.00 MHz	PN Suffix	x3		x6	
		Sort IC	TC4069UBP		TC74HCU04	
		VDD (V)	5		5	
		Rf (ohm)	1M		1M	
		Rd (ohm)	0		680	

Series	Frequency Range	CL (pf)	5	15	22	30	100
CSA-MTZ(A) CST-MTW(A)	6.31 to 13.0 MHz	PN Suffix				x00	x40
		Sort IC				CD4069UBE	TC74HCU04
		VDD (V)				12	5
		Rf (ohm)				1M	1M
		Rd (ohm)				0	220
CSA-MXZ(A) CST-MXW(A)	12.00 to 17.99 MHz	PN Suffix	xC1	xC3	xC4	x40	
		Sort IC	TC40H004P	TC40H004P	TC40H004P	TC74HCU04	
		VDD (V)	5	5	5	5	
		Rf (ohm)	1M	1M	1M	1M	
		Rd (ohm)	0	0	0	0	
	18.00 to 19.99 MHz	PN Suffix	xC1	xH3	xH4	x40	
		Sort IC	TC40H004P	TC74HCU04	TC74HCU04	TC74HCU04	
		VDD (V)	5	5	5	5	
		Rf (ohm)	1M	1M	1M	1M	
		Rd (ohm)	0	100	100	0	
	20.00 to 25.99 MHz	PN Suffix	xH1	x40	xH4	xH5	
		Sort IC	TC74HCU04	TC74HCU04	TC74HCU04	TC74HCU04	
		VDD (V)	5	5	5	5	
		Rf (ohm)	1M	1M	4.7k	3.3k	
		Rd (ohm)	100	0	0	0	
	26.00 to 60.00 MHz	PN Suffix	x04	xH3	xH4	xH5	
		Sort IC	TC74HCU04	TC74HCU04	TC74HCU04	TC74HCU04	
		VDD (V)	5	5	5	5	
		Rf (ohm)	1M	10k	4.7k	3.3k	
		Rd (ohm)	0	0	0	0	

Appendix 3

IC Characterization for Ceramic Resonators

Introduction

Due to the number of variations in clock circuits found in today's microcontrollers, it is impossible to make a standard resonator that works with every one of the ICs. While much of the time an off the shelf resonator will work with a given IC's clock circuit (by "work" we mean stable oscillation and minimal frequency shift from the intended oscillation frequency), there are many cases where the resonator will:

- not start to oscillate
- stop oscillating at high or low temperature
- have sporadic or overtone oscillation
- resulting oscillation frequency not be in expected tolerance.

Most of the problems above are due to incompatibility between the resonator, hook-up circuit, and the IC's clock circuit. This is not an indication that the resonator is defective in some way. Such incompatibilities become more of a concern in high reliability applications like airbag controllers, ABS controllers, Aircraft controls, and Medical applications.

These incompatibilities result from the fact that resonator manufacturers must pick a standard test circuit to be used in production to confirm initial oscillation frequency of the ceramic resonator. For Murata, we use the RCA CD4069UBE as the CMOS resonator test circuit, and the Toshiba TC74HCU04 or TC40H004P as the HCMOS resonator test circuit (called out by the "x40" suffix in the resonator part number). For the big picture, there are inherent differences between CMOS and HCMOS IC technology that require us to offer these three sorting options. But, within each technology (CMOS vs. HCMOS) there can be many variations in IC design and die shrink level, that cause the resonator incompatibility / oscillation difficulties.

What can we do

To overcome these incompatibilities, Murata has chosen to take the route of IC characterization. Murata has a dedicated application engineering section, whose sole function is to perform IC characterizations between customer ICs and Murata ceramic resonators. By performing the IC characterization, we are able to solve most of the resonator incompatibility issues that arise. Many solutions are just minor changes to the hook-up circuit (like changing load capacitor values), or solutions can be as major as designing a custom resonator part. Either way, the recommendation will assure you of 100% operation for your IC (assuming no changes to the IC we characterize for you) and that all resonators will be shipped to the recommended resonator specification.

Murata has been performing IC characterizations for many years and has a great deal of experience in doing the evaluations. Many IC makers looking to put resonator recommendations in their IC's databooks, come to Murata for recommendations on resonators for their ICs via the IC characterization process.

Important Points of the Characterization Service

- The service is provided free of charge.
- The IC / resonator characterization is done with worst case resonator (per Murata specification).
- The customer gets the complete recommended hook up circuit between the IC and the resonator. The customer does not need to worry about how to hook up the resonator with the IC, since we have provided it.
- The customer is advised which specific Murata resonator they should use.
- The characterization is performed with the IC over either the standard temperature range (-20C to +80C) or the automotive temperature range (-40C to +125C). The customer is also advised about effects of variations in input supply voltage. This is very important for automotive applications.
- The characterization can take into account frequency correlation issues resulting from differences between customer ICs and Murata's standard sorting circuit.
- The customer gets a form report from Murata supporting the resonator / hook-up circuit recommendation.
- Typical lead time for the characterization is 6 to 8 weeks. Due to the time involved in doing the characterization, it is important that this process occur early in the design stage.

- The IC characterization is available to both direct and distribution customers.

Murata has made available via the Internet a listing of IC / resonator characterizations done in the past. This can be found at "<http://www.murata.com/develop/index.htm>".

Please be careful with recommendations from this web site. Many IC makers change IC's (like redesigns or change the process linewidth) that have a great impact on the characterization results. Most IC makers do not easily indicate via there part number if such changes have occurred. This could result in a characterization from the web not being accurate for currently available ICs even if they have the same part number. We recommend that all new resonator design-ins should have the IC characterization done to insure good operation.

This appendix contains a form to be filled out by the customer, sales rep, or distributor rep. This appendix also contains instructions that explain what additional information is needed for the IC characterization. Please use this included form on all new IC characterization requests to Murata, since it greatly lessens the time needed to process such requests. It also insures that all the important information needed will be supplied the first time around, preventing repeated requests to the customer for additional information.

What is needed from the customer for IC characterization

For IC characterizations, please provide the following:

- 2 to 5 bulk IC samples or the actual production PC board with ICs Mounted on it (the PC board is preferred so that parasitic effects on the board can be taken into account)*
- A top View Pin-Out Diagram for the package of the IC samples.
- The supply voltage **and tolerance** that the IC will operate under in design.
- The Murata resonator part number they want characterized with the IC samples
- The temperature range that the resonator must operate over in the design.

Notes:

1. If you are using a PIC micro-controller from Microchip, please provide information on which oscillator mode (XT or HS) you are using. If you can preprogram the oscillator mode on the IC samples, it will help speed up the evaluation process. If you can not preprogram the IC, it will take an additional 1 to 2 weeks to complete the evaluation.

2. If providing IC samples on PC boards, please attach wires for the power supply & ground and mark the wires.

Complete the form attached, arrange the above needed items, and mail or pass the completed form and IC samples (and any other needed items) to a local Murata Sales Representative. If you are not sure who your local Murata sales representative is, please consult the Murata Web page at www.Murata.com. This web page will have a link to a rep locator page, that will find the Murata rep for your area. The Murata rep will send the package on to the appropriate Murata Product Manager.

Within 4 to 5 weeks, Murata will provide the Initial Recommendation Report. This report will confirm the basic Murata resonator part number that insures stable oscillation and start-up over given circuit conditions. The only item not covered by this Initial Recommendation is frequency correlation (see Note below on Frequency correlation) between the standard Murata sorting IC and the IC under characterization. Within 4 to 5 weeks after providing the Initial Recommendation Report, Murata will provide the final Formal Recommendation Report. This report will cover correlation frequency.

Note: Correlation Frequency. It is very common to see a repeatable frequency shift between resonators sorted with Murata's standard sorting circuit and the actual IC used in design. This is mainly due to the various clock oscillator designs and construction methods used in the IC industry.

The following example demonstrates correlation frequency shift: a resonator sorted by Murata's standard production sorting circuit produces a resonator exactly at 4.000MHz. When this resonator is used with a different IC (not the Murata production sorting circuit) it oscillates at 3.98MHz. This is a 0.5% shift down. This difference between Murata's standard sorting circuit and the application IC's clock circuit is the correlation frequency shift. This correlation shift is not covered under the initial oscillation frequency specification for the resonator. This correlation frequency shift occurs with all resonators, regardless of resonator maker.

** If frequency tolerance is crucial to your design, Murata is able to compensate for such a correlation shift by custom production frequency sorting or by making a custom resonator. Please note on the Evaluation Form if the initial oscillation frequency is critical to your application.

IC Evaluation Information Sheet

Resonator

(Please Print All Information)

Application Information

Application: <i>(required)</i>	
Estimated Annual Usage: <i>(required)</i>	
Production Start Date: <i>(required)</i>	
Production Location: <i>(required)</i>	

IC and Test Information

IC Maker: <i>(required)</i>	
IC Part Number: <i>(required)</i>	
Resonator Part Number: <i>(required)</i>	
Supply Voltage: (example: 5V \pm 0.5%): <i>(required, must state tolerance for voltage)</i>	
Temperature Range: <i>(required)</i>	
Number of IC samples or modules enclosed:	
Current Customer Circuit Conditions: <i>(If available)</i>	Feedback resistor (Rf) = _____ Load capacitors (CL1 / CL2) = _____
Can the circuit conditions be changed:	YES NO (please circle one)

Customer Contact Information

Customer Name: <i>(required)</i>	
Customer Contact Person: <i>(required)</i>	
Customer Contact Phone Number: <i>(required)</i>	
Customer Contact e-mail Address: <i>(If available)</i>	
Sales Rep. Name and Office:	

**Additional Comments or Requests (attach additional page if needed):

IC Characterization for Ceramic Discriminators

Introduction

Like resonators, discriminators are subject to the differences between ICs. However, these differences can affect discriminators more severely than resonators. Small differences in the characteristics of an IC can cause a large frequency shift in the discriminator that could cause a signal to be distorted or cut out completely. For this reason, Murata discriminators are IC specific, meaning that we have one discriminator for each IC.

What We Can Do

To resolve these incompatibilities, Murata performs IC characterizations to determine the discriminator characteristics required by each IC and the customer's application. Murata has a dedicated application engineering section whose sole function is to perform IC characterizations between customer ICs and Murata discriminators. Once the required characteristics are determined, a custom discriminator is produced and a part number is assigned that indicates the associated IC.

Important Points of the Characterization Service

- The service is provided free of charge
- The IC / discriminator characterization is done with the worst case discriminator (per Murata specification)
- The customer is provided with all external component values (L_S and R_P)
- The customer is advised of the discriminator part number
- The characterization is performed over the standard temperature range (-20C to +80C)
- Typical lead time for the characterization is 6 to 8 weeks. For this reason, it is important to begin the characterization early in the design stage.
- The IC characterization is available to both direct and distribution customers.

Murata has made available via the Internet a listing of IC / discriminator characterizations done in the past. This can be found at "<http://www.murata.com/develop/index.htm>". This list is also available in Appendix 5, but it is only current at the time of publication.

This appendix contains a form to be filled out by the customer, sales rep, or distributor rep. This appendix also contains instructions that explain what additional information is needed for the IC characterization. Please use this included form on all new IC characterization requests to Murata, since it greatly lessens the time needed to process such requests. It also insures that all the important information needed will be supplied the first time around, preventing repeated requests to the customer for additional information.

What is needed from the customer

The service is much the same as the resonator characterization, but we require some additional information:

- 2 to 5 bulk IC samples or the actual production PC board with ICs Mounted on it (the PC board is preferred so that parasitic effects on the board can be taken into account)*
- A top View Pin-Out Diagram for the package of the IC samples.
- The supply voltage **and tolerance** that the IC will operate under in design.
- The Murata resonator part number they want characterized with the IC samples
- The temperature range that the resonator must operate over in the design.
- The 3dB bandwidth desired
- The 3dB recovered audio voltage desired
- The signal input level
- The frequency deviation

- The modulation frequency

Note:

If providing IC samples on PC boards, please attach wires for the power supply & ground and mark the wires.

Complete the form attached, arrange the above needed items, and mail or pass the completed form and IC samples (and any other needed items) to a local Murata Sales Representative. If you are not sure who your local Murata sales representative is, please consult the Murata Web page at www.Murata.com. This web page will have a link to a rep locator page, that will find the Murata rep for your area. The Murata rep will send the package on to the appropriate Murata Product Manager.

The report will contain graphs of recovered audio voltage and total harmonic distortion for several values of R_P , L_S , C , V_{CC} , and signal input level. It will also contain the recommended values for the performance that comes closest to the desired performance indicated on the Characterization Form.

IC Evaluation Information Sheet

Discriminator

(Please Print All Information)

Customer Information

Customer Name: <i>(required)</i>	
Application: <i>(required)</i>	
Estimated Annual Usage: <i>(required)</i>	
Production Start Date: <i>(required)</i>	

IC Information

IC Maker: <i>(required)</i>	
IC Part Number: <i>(required)</i>	
Discriminator Part Number: <i>(required)</i>	
Target 3dB Bandwidth: <i>(example: ± 100kHz)</i> <i>(required)</i>	
Target 3dB Recovered Audio Voltage: <i>(example: 100mV) (required)</i>	
Signal Input Level: <i>(example: 100dBu)</i> <i>(required)</i>	
Frequency Deviation: <i>(example: +75kHz)</i> <i>(required)</i>	
Modulation Frequency: <i>(example: 1kHz)</i> <i>(required)</i>	
Supply Voltage: <i>(example: 5V ± 0.5%)</i> : <i>(required. must state tolerance for voltage)</i>	

Customer Contact Information

Company Name: <i>(required)</i>	
Contact Name: <i>(required)</i>	
Contact Phone Number: <i>(required)</i>	
Sales Rep. Name and Office:	

Number of IC samples enclosed: _____

**Additional Comments or Requests (attach additional page if needed):

Appendix 4

EIA-J Date Code System

The EIA-J date code system uses twenty-four letters, omitting I and O, to indicate the month when a product was made. This system works on a four year cycle. Capital letters are used for the first two years and lower case letters are used for the next two years. This system was started in 1977 and follows the table below.

Year	Month	Letter	Year	Month	Letter	Year	Month	Letter	Year	Month	Letter
1977 1981 1985 1989 1993 1997 2001 2005	1	A	1978 1982 1986 1990 1994 1998 2002 2006	1	N	1979 1983 1987 1991 1995 1999 2003 2007	1	a	1980 1984 1988 1992 1996 2000 2004 2008	1	n
	2	B		2	P		2	b		2	o
	3	C		3	Q		3	c̄		3	g
	4	D		4	R		4	d		4	r
	5	E		5	S		5	e		5	s
	6	F		6	T		6	f		6	t
	7	G		7	U		7	g		7	u
	8	H		8	V		8	h		8	v
	9	J		9	W		9	j		9	w
	10	K		10	X		10	k		10	x
	11	L		11	Y		11	l		11	y
	12	M		12	Z		12	m		12	z

Table 17. EIA-J Date Code System

Appendix 5

Discriminator Characterization List

The following tables list the discriminators offered by Murata and the ICs that they work with. Table 18 is a list of MHz discriminators by IC manufacturer, Table 19 is a list of MHz discriminators by discriminator part number, and Table 20 is a list of the kHz discriminators.

Audio Application IC		
IC Manufacturer	IC	Part Number
NEC	μPC1391M	CDA10.7MG56
Panasonic	AN7004	CDA10.7MG11
	AN7006S	CDA10.7MG14A
	AN7007SU	CDA10.7MG13
	AN7232	CDA10.7MG53
	BA1440	CDA10.7MG19
Rohm	BA1448	CDA10.7MG60
	BA4110	CDA10.7MG66
	BA4220	CDA10.7MG41
	BA4230AF	CDA10.7MG5
	BA4234L	CDA10.7MG4
	BA4240L	CDA10.7MG67
	Sanyo	LA1260
LA1805		CDA10.7MG26
LA1810		CDA10.7MG22
LA1816		CDA10.7MG15
LA1827		CDA10.7MG83
LA1830		CDA10.7MG37
LA1831		CDA10.7MG43
LA1832/M		CDA10.7MG46
		CDACV10.7MG46
LA1835/M		CDA10.7MG48
LA1838/M		CDA10.7MG74
		CDA10.7MG79
Sony		CX-20029
		CDACV10.7MG1
	CX-20076	CDA10.7MG2
	CXA1030P	CDA10.7MG12
	CXA1238	CDA10.7MG1
	CXA1376AM	CDA10.7MG54
	CXA1538M/N/S	CDA10.7MG69
	CXA1611	CDA10.7MG75
Toko	TK14581	CDA10.7MG62
Toshiba	TA2003	CDA10.7MG31
	TA2007N	CDA10.7MG33
	TA2008A/AN	CDA10.7MG45
	TA2022	CDA10.7MG50
	TA2029	CDA10.7MG36
	TA2046	CDA10.7MG58
	TA2057	CDA10.7MG57
	TA2099N	CDA10.7MG82
	TA2104F	CDA10.7MG80A
	TA2111	CDA10.7MG77

Table 18. MHz Discriminators By IC Manufacturer

	TA7130P	CDA10.7MG9
	TA7303	CDA10.7MG8
	TA7640AP	CDA10.7MG6
	TA7765	CDA10.7MG71
	TA8122AN/AF	CDA10.7MG16
		CDACV10.7MG16
	TA8124P	CDA10.7MGF226
	TA8132AN/AF	CDA10.7MG18
	TA8186	CDA10.7MG39
Samsung	KA2292	CDA10.7MG63
	KA2295	CDA10.7MG64
	KA2298	CDA10.7MG65
Motorola	MC13156	CDA10.7MG49
	MC13173	CDA10.7MG52
Philips	TBA120U	CDA10.7MG29
	TBA229-2	CDA10.7MG21A
	TEA5592	CDA10.7MG30
	TEA5594	CDA10.7MG35
	TEA5710	CDA10.7MG40
	TEA5712T	CDA10.7MG55
	TEA5762/5757	CDA10.7MG61
Siemens	TDA1576T	CDA10.7MG51
Telefunken	U2501B	CDA10.7MG28
	U4313B	CDA10.7MG81
	U4490B	CDA10.7MG34V

Visual Application IC

IC Manufacturer	IC	Part Number
Hitachi	HA1129	CDSH(4.5/5.5/6.0/6.5)MC18K
	HA11566NT	CDSH(4.5/5.5/6.0/6.5)ME46K
Mitsubishi	M51316BP	CDSH(4.5/5.5/6.0/6.5)MC28K
	M51316P	CDSH(4.5/5.5/6.0/6.5)MC23K
	M51345FP	CDSH(4.5/5.5/6.0/6.5)MC35K
	M51346BP	CDSH(4.5/5.5/6.0/6.5)ME19K
	M51346P	CDSH(4.5/5.5/6.0/6.5)ME6K
	M51348FP	CDSH(4.5/5.5/6.0/6.5)MC30K
		CDSH(4.5/5.5/6.0/6.5)ME72K
	M51354AP	CDSH(4.5/5.5/6.0/6.5)MC22K
	M51362SP	CDSH(4.5/5.5/6.0/6.5)ME58K
	M51365SP	CDSH(4.5/5.5/6.0/6.5)MC29K
	M51496P	CDSH(4.5/5.5/6.0/6.5)ME23K
	M52007FP	CDSH(4.5/5.5/6.0/6.5)ME70K
	M52014SP	CDSH(4.5/5.5/6.0/6.5)ME47K
	M52018FP	CDSH(4.5/5.5/6.0/6.5)MC41K
	M52031FP	CDSH(4.5/5.5/6.0/6.5)MC44K
	M52034FP	CDSH(4.5/5.5/6.0/6.5)ME44K
	M52044FP	CDSH(4.5/5.5/6.0/6.5)ME43K
	M52311FP	CDSH(4.5/5.5/6.0/6.5)ME52K
	M52313SP	CDSH(4.5/5.5/6.0/6.5)ME74K
	M52314SP	CDSH(4.5/5.5/6.0/6.5)ME61K
	M52316SP	CDSH(4.5/5.5/6.0/6.5)ME65K
	M52318SP	CDSH(4.5/5.5/6.0/6.5)ME60K
	M52322FP	CDSH(4.5/5.5/6.0/6.5)ME55K
	M52335SP	CDSH(4.5/5.5/6.0/6.5)ME67K

Table 18. MHz Discriminators By IC Manufacturer

	M52339	CDSH(4.5/5.5/6.0/6.5)ME68K
	M52395SP	CDSH(4.5/5.5/6.0/6.5)ME76K
NEC	μPC1167C2	CDSH(4.5/5.5/6.0/6.5)MC11K
	μPC1382C	CDSH(4.5/5.5/6.0/6.5)MC20K
	μPC1383C	CDSH(4.5/5.5/6.0/6.5)MC21K
	μPC1391H	CDSH(4.5/5.5/6.0/6.5)MC19K
	μPC1411CA	CDSH(4.5/5.5/6.0/6.5)MC27K
	μPC1414CA	CDSH(4.5/5.5/6.0/6.5)MC42K
	μPC1416G	CDSH(4.5/5.5/6.0/6.5)MC33K
	μPC1800CA	CDSH(4.5/5.5/6.0/6.5)ME29K
Panasonic	AN5135NK	CDSH(4.5/5.5/6.0/6.5)ME5K
	AN5138NK	CDSH(4.5/5.5/6.0/6.5)ME17K
	AN5155K	CDSH(4.5/5.5/6.0/6.5)ME12K
	AN5176K	CDSH(4.5/5.5/6.0/6.5)ME62K
	AN5180NK	CDSH(4.5/5.5/6.0/6.5)ME63K
Sanyo	LA1150	CDSH(4.5/5.5/6.0/6.5)ME31K
	LA1231N	CDSH(4.5/5.5/6.0/6.5)MC36K
	LA7520	CDSH(4.5/5.5/6.0/6.5)MC24K
	LA7521	CDSH(4.5/5.5/6.0/6.5)MC25K
	LA7530	CDSH(4.5/5.5/6.0/6.5)MC26K
	LA7540	CDSH(4.5/5.5/6.0/6.5)ME18K
	LA7541	CDSH(4.5/5.5/6.0/6.5)ME16K
	LA7545	CDSH(4.5/5.5/6.0/6.5)ME21K
	LA7550/7555	CDSH(4.5/5.5/6.0/6.5)ME20K
	LA7575	CDSH(4.5/5.5/6.0/6.5)ME41K
	LA7577	CDSH(4.5/5.5/6.0/6.5)ME49K
	LA7650	CDSH(4.5/5.5/6.0/6.5)ME27K
	LA7655	CDSH(4.5/5.5/6.0/6.5)ME28K
	LA7670/7671	CDSH(4.5/5.5/6.0/6.5)ME42K
	LA7680/7681	CDSH(4.5/5.5/6.0/6.5)ME35K
	LA7685	CDSH(4.5/5.5/6.0/6.5)ME51K
	LA7770	CDA10.7MG23
Sony	CX-20014	CDSH(4.5/5.5/6.0/6.5)ME1K
	CXA1110AS	CDSH(4.5/5.5/6.0/6.5)ME30K
	CXA3067	CDA10.7MG76
Toko	TK10489N	CDSH(4.5/5.5/6.0/6.5)ME64K
	TK1048M	CDSH(4.5/5.5/6.0/6.5)ME59K
Toshiba	TA1201N/AN	CDSH(4.5/5.5/6.0/6.5)ME71K
	TA1209F	CDA10.7MA28
	TA7146P	CDSH(4.5/5.5/6.0/6.5)MC15K
	TA7522	CDSH(4.5/5.5/6.0/6.5)MC32K
	TA7678AP	CDSH(4.5/5.5/6.0/6.5)ME3K
	TA7680AP	CDSH(4.5/5.5/6.0/6.5)ME11K
	TA8646N	CDSH(4.5/5.5/6.0/6.5)MC40K
	TA8670F	CDSH(4.5/5.5/6.0/6.5)MC37K
	TA8680N	CDSH(4.5/5.5/6.0/6.5)ME34K
	TA8691	CDSH(4.5/5.5/6.0/6.5)ME37K
	TA8701N	CDSH(4.5/5.5/6.0/6.5)MC38K
		CDSH(4.5/5.5/6.0/6.5)ME69K
	TA8721SN	CDSH(4.5/5.5/6.0/6.5)MC39K
	TA8825N	CDSH(4.5/5.5/6.0/6.5)ME77K
	TA8864N	CDSH(4.5/5.5/6.0/6.5)ME50K
CDSH(4.5/5.5/6.0/6.5)MC46K		
CDSH(4.5/5.5/6.0/6.5)MC47K		

Table 18. MHz Discriminators By IC Manufacturer

LG	GL3815	CDSH(4.5/5.5/6.0/6.5)ME48K
Samsung	KA2244	CDA(4.5/5.5/6.0/6.5)MG59V
	KA2245	CDSH(4.5/5.5/6.0/6.5)ME79K
	KA2268	CDSH(4.5/5.5/6.0/6.5)ME73K
	KA2919	CDSH(4.5/5.5/6.0/6.5)ME75K
Motorola	MC13055	CDSH(4.5/5.5/6.0/6.5)ME56K
	MC1357	CDSH(4.5/5.5/6.0/6.5)MC14K
	MC3356	CDSH(4.5/5.5/6.0/6.5)ME14K
Philips	NE604	CDSH(4.5/5.5/6.0/6.5)ME38K
	TBA229-2	CDA(4.5/5.5/6.0/6.5)MG21
	TDA2557	CDA(4.5/5.5/6.0/6.5)MG24
	ULN2111A	CDSH(4.5/5.5/6.0/6.5)MC13K
Siemens	A224D	CDSH(4.5/5.5/6.0/6.5)MC43K
	TBA120S	CDSH(4.5/5.5/6.0/6.5)ME15K
	TBA120T	CDSH(4.5/5.5/6.0/6.5)MC10K
	TBA120U	CDSH(4.5/5.5/6.0/6.5)ME13K
	TBA129	CDSH(4.5/5.5/6.0/6.5)ME8K
	TBA130-2	CDSH(4.5/5.5/6.0/6.5)MC34K
	TBA229	CDSH(4.5/5.5/6.0/6.5)ME9K
	TBA229-2	CDSH(4.5/5.5/6.0/6.5)ME32K
	TBA4280	CDSH(4.5/5.5/6.0/6.5)MC17K
	TBA750	CDSH(4.5/5.5/6.0/6.5)MC12K
	TDA2460	CDSH(4.5/5.5/6.0/6.5)ME33K
	TDA2546A	CDSH(4.5/5.5/6.0/6.5)ME10K
	TDA2555/2557	CDSH(4.5/5.5/6.0/6.5)ME25K
	TDA2556	CDSH(4.5/5.5/6.0/6.5)ME22K
	TDA3800GS	CDSH(4.5/5.5/6.0/6.5)ME24K
	TDA3827	CDSH(4.5/5.5/6.0/6.5)ME40K
	TDA3857	CDSH(4.5/5.5/6.0/6.5)ME54K
	TDA3858	CDSH(4.5/5.5/6.0/6.5)ME57K
	TDA4282T	CDSH(4.5/5.5/6.0/6.5)MC31K
	TDA4481	CDSH(4.5/5.5/6.0/6.5)ME66K
	TDA4503	CDSH(4.5/5.5/6.0/6.5)ME7K
	TDA4504	CDSH(4.5/5.5/6.0/6.5)ME26K
	TDA4940	CDSH(4.5/5.5/6.0/6.5)MC16K
	TDA6160-2X	CDA(4.5/5.5/6.0/6.5)MG44V
	TDA6160X	CDA(4.5/5.5/6.0/6.5)MG38V
	TDA8192	CDSH(4.5/5.5/6.0/6.5)ME39K
	TDA8222	CDSH(4.5/5.5/6.0/6.5)ME53K
	TDA8305	CDSH(4.5/5.5/6.0/6.5)ME45K
Telefunken	U2840B	CDSH(4.5/5.5/6.0/6.5)MC45K
	U829B	CDA(4.5/5.5/6.0/6.5)MG25
		CDSH(4.5/5.5/6.0/6.5)ME36K

Table 18. MHz Discriminators By IC Manufacturer

Part Number	IC Manufacturer	IC
CDSH...MC Type		
CDSH(4.5/5.5/6.0/6.5)MC10K	Siemens	TBA120T
CDSH(4.5/5.5/6.0/6.5)MC11K	NEC	μPC1167C2
CDSH(4.5/5.5/6.0/6.5)MC12K	Siemens	TBA750
CDSH(4.5/5.5/6.0/6.5)MC13K	Philips	ULN2111A
CDSH(4.5/5.5/6.0/6.5)MC14K	Motorola	MC1357
CDSH(4.5/5.5/6.0/6.5)MC15K	Toshiba	TA7146P
CDSH(4.5/5.5/6.0/6.5)MC16K	Siemens	TDA4940
CDSH(4.5/5.5/6.0/6.5)MC17K	Siemens	TBA4280
CDSH(4.5/5.5/6.0/6.5)MC18K	Hitachi	HA1129
CDSH(4.5/5.5/6.0/6.5)MC19K	NEC	μPC1391H
CDSH(4.5/5.5/6.0/6.5)MC20K	NEC	μPC1382C
CDSH(4.5/5.5/6.0/6.5)MC21K	NEC	μPC1383C
CDSH(4.5/5.5/6.0/6.5)MC22K	Mitsubishi	M51354AP
CDSH(4.5/5.5/6.0/6.5)MC23K	Mitsubishi	M51316P
CDSH(4.5/5.5/6.0/6.5)MC24K	Sanyo	LA7520
CDSH(4.5/5.5/6.0/6.5)MC25K	Sanyo	LA7521
CDSH(4.5/5.5/6.0/6.5)MC26K	Sanyo	LA7530
CDSH(4.5/5.5/6.0/6.5)MC27K	NEC	μPC1411CA
CDSH(4.5/5.5/6.0/6.5)MC28K	Mitsubishi	M51316BP
CDSH(4.5/5.5/6.0/6.5)MC29K	Mitsubishi	M51365SP
CDSH(4.5/5.5/6.0/6.5)MC30K	Mitsubishi	M51348FP
CDSH(4.5/5.5/6.0/6.5)MC31K	Siemens	TDA4282T
CDSH(4.5/5.5/6.0/6.5)MC32K	Toshiba	TA7522
CDSH(4.5/5.5/6.0/6.5)MC33K	NEC	μPC1416G
CDSH(4.5/5.5/6.0/6.5)MC34K	Siemens	TBA130-2
CDSH(4.5/5.5/6.0/6.5)MC35K	Mitsubishi	M51345FP
CDSH(4.5/5.5/6.0/6.5)MC36K	Sanyo	LA1231N
CDSH(4.5/5.5/6.0/6.5)MC37K	Toshiba	TA8670F
CDSH(4.5/5.5/6.0/6.5)MC38K	Toshiba	TA8701N
CDSH(4.5/5.5/6.0/6.5)MC39K	Toshiba	TA8721SN
CDSH(4.5/5.5/6.0/6.5)MC40K	Toshiba	TA8646N
CDSH(4.5/5.5/6.0/6.5)MC41K	Mitsubishi	M52018FP
CDSH(4.5/5.5/6.0/6.5)MC42K	NEC	μPC1414CA
CDSH(4.5/5.5/6.0/6.5)MC43K	Siemens	A224D
CDSH(4.5/5.5/6.0/6.5)MC44K	Mitsubishi	M52031FP
CDSH(4.5/5.5/6.0/6.5)MC45K	Telefunken	U2840B
CDSH(4.5/5.5/6.0/6.5)MC46K	Toshiba	TA8867F
CDSH(4.5/5.5/6.0/6.5)MC47K	Toshiba	TA8867FA
CDSH...ME Type		
CDSH(4.5/5.5/6.0/6.5)ME1K	Sony	CX-20014
CDSH(4.5/5.5/6.0/6.5)ME3K	Toshiba	TA7678AP
CDSH(4.5/5.5/6.0/6.5)ME5K	Panasonic	AN5135NK
CDSH(4.5/5.5/6.0/6.5)ME6K	Mitsubishi	M51346P
CDSH(4.5/5.5/6.0/6.5)ME7K	Siemens	TDA4503
CDSH(4.5/5.5/6.0/6.5)ME8K	Siemens	TBA129
CDSH(4.5/5.5/6.0/6.5)ME9K	Siemens	TBA229
CDSH(4.5/5.5/6.0/6.5)ME10K	Siemens	TDA2546A
CDSH(4.5/5.5/6.0/6.5)ME11K	Toshiba	TA7680AP
CDSH(4.5/5.5/6.0/6.5)ME12K	Panasonic	AN5155K
CDSH(4.5/5.5/6.0/6.5)ME13K	Siemens	TBA120U

Table 19. MHz Discriminators By Part Number

CDSH(4.5/5.5/6.0/6.5)ME14K	Motorola	MC3356
CDSH(4.5/5.5/6.0/6.5)ME15K	Siemens	TBA120S
CDSH(4.5/5.5/6.0/6.5)ME16K	Sanyo	LA7541
CDSH(4.5/5.5/6.0/6.5)ME17K	Panasonic	AN5138NK
CDSH(4.5/5.5/6.0/6.5)ME18K	Sanyo	LA7540
CDSH(4.5/5.5/6.0/6.5)ME19K	Mitsubishi	M51346BP
CDSH(4.5/5.5/6.0/6.5)ME20K	Sanyo	LA7550/7555
CDSH(4.5/5.5/6.0/6.5)ME21K	Sanyo	LA7545
CDSH(4.5/5.5/6.0/6.5)ME22K	Siemens	TDA2556
CDSH(4.5/5.5/6.0/6.5)ME23K	Mitsubishi	M51496P
CDSH(4.5/5.5/6.0/6.5)ME24K	Siemens	TDA3800GS
CDSH(4.5/5.5/6.0/6.5)ME25K	Siemens	TDA2555/2557
CDSH(4.5/5.5/6.0/6.5)ME26K	Siemens	TDA4505
CDSH(4.5/5.5/6.0/6.5)ME27K	Sanyo	LA650
CDSH(4.5/5.5/6.0/6.5)ME28K	Sanyo	LA7655
CDSH(4.5/5.5/6.0/6.5)ME29K	NEC	μPC1800CA
CDSH(4.5/5.5/6.0/6.5)ME30K	Sony	CXA1110AS
CDSH(4.5/5.5/6.0/6.5)ME31K	Sanyo	LA1150
CDSH(4.5/5.5/6.0/6.5)ME32K	Siemens	TBA229-2
CDSH(4.5/5.5/6.0/6.5)ME33K	Siemens	TDA2460
CDSH(4.5/5.5/6.0/6.5)ME34K	Toshiba	TA8680N
CDSH(4.5/5.5/6.0/6.5)ME35K	Sanyo	LA7680/7681
CDSH(4.5/5.5/6.0/6.5)ME36K	Telefunken	U829B
CDSH(4.5/5.5/6.0/6.5)ME37K	Toshiba	TA8691N
CDSH(4.5/5.5/6.0/6.5)ME38K	Philips	NE604
CDSH(4.5/5.5/6.0/6.5)ME39K	Siemens	TDA8192
CDSH(4.5/5.5/6.0/6.5)ME40K	Siemens	TDA3827
CDSH(4.5/5.5/6.0/6.5)ME41K	Sanyo	LA7575
CDSH(4.5/5.5/6.0/6.5)ME42K	Sanyo	LA7670/7671
CDSH(4.5/5.5/6.0/6.5)ME43K	Mitsubishi	M52044FP
CDSH(4.5/5.5/6.0/6.5)ME44K	Mitsubishi	M52034FP
CDSH(4.5/5.5/6.0/6.5)ME45K	Siemens	TDA8305
CDSH(4.5/5.5/6.0/6.5)ME46K	Hitachi	HA11566NT
CDSH(4.5/5.5/6.0/6.5)ME47K	Mitsubishi	M52014SP
CDSH(4.5/5.5/6.0/6.5)ME48K	LG	GL3815
CDSH(4.5/5.5/6.0/6.5)ME49K	Sanyo	LA7577
CDSH(4.5/5.5/6.0/6.5)ME50K	Toshiba	TA8864N
CDSH(4.5/5.5/6.0/6.5)ME51K	Sanyo	LA7685
CDSH(4.5/5.5/6.0/6.5)ME52K	Mitsubishi	M52311FP
CDSH(4.5/5.5/6.0/6.5)ME53K	Siemens	TDA8222
CDSH(4.5/5.5/6.0/6.5)ME54K	Siemens	TDA3857
CDSH(4.5/5.5/6.0/6.5)ME55K	Mitsubishi	M52322FP
CDSH(4.5/5.5/6.0/6.5)ME56K	Motorola	MC13055
CDSH(4.5/5.5/6.0/6.5)ME57K	Siemens	TDA3858
CDSH(4.5/5.5/6.0/6.5)ME58K	Mitsubishi	M51362SP
CDSH(4.5/5.5/6.0/6.5)ME59K	Toko	TK1048M
CDSH(4.5/5.5/6.0/6.5)ME60K	Mitsubishi	M52318SP
CDSH(4.5/5.5/6.0/6.5)ME61K	Mitsubishi	M52314SP
CDSH(4.5/5.5/6.0/6.5)ME62K	Panasonic	AN5176K
CDSH(4.5/5.5/6.0/6.5)ME63K	Panasonic	AN5180NK
CDSH(4.5/5.5/6.0/6.5)ME64K	Toko	TK10489N
CDSH(4.5/5.5/6.0/6.5)ME65K	Mitsubishi	M52316SP
CDSH(4.5/5.5/6.0/6.5)ME66K	Siemens	TDA4481
CDSH(4.5/5.5/6.0/6.5)ME67K	Mitsubishi	M52335SP

Table 19. MHz Discriminators By Part Number

CDSH(4.5/5.5/6.0/6.5)ME68K	Mitsubishi	M52339
CDSH(4.5/5.5/6.0/6.5)ME69K	Toshiba	TA8701N
CDSH(4.5/5.5/6.0/6.5)ME70K	Mitsubishi	M52007FP
CDSH(4.5/5.5/6.0/6.5)ME71K	Toshiba	TA1201N/AN
CDSH(4.5/5.5/6.0/6.5)ME72K	Mitsubishi	M51348FP
CDSH(4.5/5.5/6.0/6.5)ME73K	Samsung	KA2268
CDSH(4.5/5.5/6.0/6.5)ME74K	Mitsubishi	M52313SP
CDSH(4.5/5.5/6.0/6.5)ME75K	Samsung	KA2919
CDSH(4.5/5.5/6.0/6.5)ME76K	Mitsubishi	M52395SP
CDSH(4.5/5.5/6.0/6.5)ME77K	Toshiba	TA8825N
CDSH(4.5/5.5/6.0/6.5)ME79K	Samsung	KA2245
CDSH(4.5/5.5/6.0/6.5)ME80B	Toshiba	TA31161
CDSH(4.5/5.5/6.0/6.5)ME81K	Sanyo	LA1150
CDA...MG Type		
CDA(4.5/5.5/6.0/6.5)MG21	Philips	TBA229-2
CDA(4.5/5.5/6.0/6.5)MG24	Philips	TDA2557
CDA(4.5/5.5/6.0/6.5)MG25	Telefunken	U829B
CDA(4.5/5.5/6.0/6.5)MG38V	Siemens	TDA6160X
CDA(4.5/5.5/6.0/6.5)MG44V	Siemens	TDA6160-2X
CDA(4.5/5.5/6.0/6.5)MG59V	Samsung	KA2244
CDA10.7MG1	Sony	CX-20029/20030
CDA10.7MG1	Sony	CXA1238
CDA10.7MG2	Sony	CX-20076
CDA10.7MG4	Rohm	BA4234L
CDA10.7MG5	Rohm	BA4230AF
CDA10.7MG6	Toshiba	TA7640AP
CDA10.7MG7	Sanyo	LA1260
CDA10.7MG8	Toshiba	TA7303P
CDA10.7MG9	Toshiba	TA7130P
CDA10.7MG11	Panasonic	AN7004
CDA10.7MG12	Sony	CXA1030P
CDA10.7MG13	Panasonic	AN7007SU
CDA10.7MG14A	Panasonic	AN7006S
CDA10.7MG15	Sanyo	LA1816
CDA10.7MG16	Toshiba	TA8122AN/AF
CDA10.7MG18	Toshiba	TA8132AN/AF
CDA10.7MG19	Rohm	BA1440
CDA10.7MG21A	Philips	TBA229-2
CDA10.7MG22	Sanyo	LA1810
CDA10.7MG23	Sanyo	LA7770
CDA10.7MG26	Sanyo	LA1805
CDA10.7MG28	Telefunken	U2501B
CDA10.7MG29	Philips	TBA120U
CDA10.7MG30	Philips	TEA5592
CDA10.7MG31	Toshiba	TA2003
CDA10.7MG33	Toshiba	TA2007N
CDA10.7MG34V	Telefunken	U4490B
CDA10.7MG35	Philips	TEA5594
CDA10.7MG36	Toshiba	TA2029
CDA10.7MG37	Sanyo	LA1830
CDA10.7MG39	Toshiba	TA8186
CDA10.7MG40	Philips	TEA5710
CDA10.7MG41	Rohm	BA4220
CDA10.7MG43	Sanyo	LA1831

Table 19. MHz Discriminators By Part Number

CDA10.7MG45	Toshiba	TA2008A/AN
CDA10.7MG46	Sanyo	LA1832/M
CDA10.7MG48	Sanyo	LA1835/M
CDA10.7MG49	Motorola	MC13156
CDA10.7MG50	Toshiba	TA2022
CDA10.7MG51	CDB455CL13	TDA1576T
CDA10.7MG52	Motorola	MC13173
CDA10.7MG53	Panasonic	AN7232
CDA10.7MG54	Sony	CXA1376AM
CDA10.7MG55	Philips	TEA5712T
CDA10.7MG56	NEC	μPC1391M
CDA10.7MG57	Toshiba	TA2057
CDA10.7MG58	Toshiba	TA2046
CDA10.7MG60	Rohm	BA1448
CDA10.7MG61	Philips	TEA5762/5757
CDA10.7MG62	Toko	TK14581
CDA10.7MG63	Samsung	KA2292
CDA10.7MG64	Samsung	KA2295
CDA10.7MG65	Samsung	KA2298
CDA10.7MG66	Rohm	BA4110
CDA10.7MG67	Rohm	BA4240L
CDA10.7MG69	Sony	CXA1538M/N/S
CDA10.7MG71	Toshiba	TA7765
CDA10.7MG74	Sanyo	LA1838/M
CDA10.7MG75	Sony	CXA1611
CDA10.7MG77	Toshiba	TA2111
CDA10.7MG79	Sanyo	LA1838/M
CDA10.7MG80A	Toshiba	TA2104F
CDA10.7MG80	Toshiba	TA2104AFN
CDA10.7MG81	Telefunken	U4313B
CDA10.7MG82	Toshiba	TA2099N
CDA10.7MG83	Sanyo	LA1827
CDA10.7MG84	Rohm	BH4126FV
CDA10.7MG85	Philips	SA639
CDA10.7MG86	Sanyo	LA1833
CDA10.7MG87	Motorola	MC3363
CDA10.7MG88	Toshiba	TA8721ASN
CDA...MA Type		
CDA10.7MA28	Toshiba	TA1209F
CDACV...MG Type		
CDACV10.7MG1	Sony	CX-20029
CDACV10.7MG16	Toshiba	TA8122AN
CDACV10.7MG46	Sanyo	LA1832

Table 19. MHz Discriminators By Part Number

CDB Part Number	CDBM Part Number	CDBC Part Number	IC Manufacturer	IC
CDB455C1	CDBM455C1		Siemens	S004
	CDBM455C2	CDBC455CX2	Toshiba	TA8104F
	CDBM455C2	CDBC455CX2	Motorola	MC3357
CDB455C3	CDBM455C3	CDBC455CX3	Sony	CXA1184M
	CDBM455C4		Sanyo	LA8610
CDB455C5	CDBM455C5		NEC	PC1167C

Table 20. kHz Discriminator List

CDB455C7	CDBM455C7	CDBC455CX7	Motorola	MC3357
CDB455C8	CDBM455C8		Siemens	TDA1576S1
CDB455C9	CDBM455C9	CDBC455CX9	Philips	NE604
CDB455CL9	CDBM455CL9	CDBC455CLX9	Philips	NE604
CDB455C10	CDBM455C10		Toshiba	TA8103F
CDB455C11			Siemens	S1469
CDB455C12	CDBM455C12		Plessey	SL6652
CDB455C13			Sony	CXA1003BM
CDB455C13A	CDBM455C13A	CDBC455CX13A	Sony	CXA1003AM/BM
CDB455CL13	CDBM455CL13	CDBC455CLX13	Sony	CXA1003AM/BM
CDB455C14	CDBM455C14		Plessey	SL6654
	CDBM455C15		Sony	CXA1183M
CDB455C16	CDBM455C16	CDBC455CX16	Motorola	MC3372
CDB455C17			Plessey	SL6655
	CDBM455C18		Motorola	MC3371
	CDBM455C20		Toshiba	TA8104F
CDB455C19	CDBM45519	CDBC455CX19	Matsushita	AN6436S
CDB455C21	CDBM455C21	CDBC455CX21	Toshiba	TA31132F
CDB455CL21	CDBM455CL21	CDBC455CLX21	Toshiba	TA31132F
CDB455C22			Sanyo	LA8604M
	CDBM455C23		Toshiba	TA7761F
CDB455C24	CDBM455C24	CDBC455CX24	Toshiba	TA31136F
	CDBM455C25		Sony	CXA1484N
	CDBM455C26		JRC	NJM2232A
CDB455C27	CDBM455C27	CDBC455CX27	Toko	TK10487
CDB455C28	CDBM455C28	CDBC455CX28	Toshiba	TA31142F
CDB455C29	CDBM455C29	CDBC455CX29	Philips	NE605
	CDBM455CL29	CDBC455CLX29	Philips	NE605
CDB455C30	CDBM455C30	CDBC455CX30	Toko	TK14501
	CDBM455C31	CDBC455CX31	Toshiba	TA31141
CDB455C32	CDBM455C32	CDBC455CX32	Toshiba	TA31143F
	CDBM455C33	CDBC455CX33	Sony	CXA1474
CDB455C34	CDBM455C34		Motorola	MC13136
CDB455C35	CDBM455C35	CDBC455CX35	Toko	TK10930
	CDBM455C36	CDBC455CX36	Philips	NE606/616
		CDBC455CX37	Hitachi	HA16841
CDB455C38			Lucent	W2005
	CDBM455C39	CDBC455CX39	Philips	SA607/617
CDB455C40	CDBM455C40	CDBC455CX40	Toshiba	TA31145
	CDBM455C41	CDBC455CX41	Matsushita	AN6159FA
CDB455C42	CDBM455C42	CDBC455CX42	Toko	TK14590V/14591V
CDB455C43	CDBM455C43	CDBC455CX43	Sony	CXA1683M
CDB455C44			Plessey	SL6659
CDB455C46	CDBM455C46	CDBC455CX46	NEC	KC7357
CDB455C47	CDBM455C47	CDBC455CX47	Toshiba	TA31147
	CDBM455C48	CDBC455CX48	Motorola	MC13110
CDB455C49	CDBM455C49	CDBC455CX49	Motorola	MC3361
CDB455C50	CDBM455C50	CDBC455CX50	Sony	CXA3117N
	CDBM455C51		Toshiba	TA8104F
	CDBM455C52	CDBC455CX52	Philips	SA625
CDB455C53	CDBM455C53	CDBC455CX53	Sanyo	LA8608V
CDB455C54	CDBM455C54	CDBC455CX54	Toshiba	TA31149

Table 20. kHz Discriminator List

Appendix 6

Internal Elements of Murata's Encased Buzzers

Table 21 lists the buzzer elements that are inside Murata's encased buzzers.

Part Number	Internal Element
External Drive	
PKM11-4A0	7BB-20-6-3
PKM13EPY-4000-TF01	7NB-11-9
PKM13EPY-4002	7NB-11-9
PKM17EPP-4001	7BB-15-5
PKM17EW-2001	6NB-15-10DM-3
PKM22EP-2001	7BB-20-4
PKM22EPP-2001	7BB-20-3
PKM22EPP-4001	7BB-20-6-1
PKM22EPP-4005	7BB-20-6-1
PKM22EPP-4007	7BB-20-6-1
PKM35-4A0	7BB-15-6-2
Self Drive	
PKM11-6A0	7BB-20-6
PKM24SP-3805	7NB-21-4C-2
PKM25-6A0	7SB-21-7C
PKM29-3A0	7SB-34R7-3C
Internal Circuit	
PKB24SPC-3601	7NB-21-4C-1
PKB24SW-3301	7NB-21-3C
PKB30SPC-2001	7NB-27-3C-3
PKB30SPC-3001	7NB-27-3C-2
PKB5-3A0	7BB-35-3R1C
PKB6-5A0	7BB-27-4C
Speaker	
VSB35EW-0701B	PMGB0252-01
VSB50EW-0301B	PMGB0242-01
Receiver	
PKD17EW-01R	6NB-16R3G-12DM-2
PKD22EW-01R	6NB-19R4-14DM-2R2
PKD33EW-01R	6NB-31R2-1R6
Ringer	
PKM33EP-1201C	7NB-31R2-1
PKM34EW-1101C	7NB-31R2-1
PKM34EW-1201C	7NB-31R2-1R4
PKM44EP-0901	7NB-41-25DM-1
PKM44EW-1001C	7NB-41-1
Special Application	
PKM17EPT-4001	7BB-15-6
PKM22EPT-2001	7BB-20-3
PKM22EPT-4001	7BB-20-6
PKM30SPT-2001	7NB-27-2C-3

Table 21. Encased Buzzer Internal Elements

PKM30SPT-2501	7NB-27-2R7C-1
SMD Buzzer	
PKMC16E-4000-TY	7NB-14R1-14R1-4

Table 21. Encased Buzzer Internal Elements

Appendix 7

Piezo Products Taping Lists

The following table lists the taping suffix and minimum order quantities for Murata's piezo products.

Bulk Part Number	Taping/Magazine Part Number	Quantity/Unit		Remarks
		Bulk	Taping/Magazine	
kHz Ceramic Resonators				
Non-washable Type (Magazine)				
CSB...P (375 - 429kHz)	CSB...P-CA01	500	50	
CSB...E (430 - 509kHz)	CSB...E-CA01	500	50	
CSB...P (510 - 699kHz)	CSB...P-CA01	500	50	
CSU...P (450 - 500kHz)	CSU...P-CA01	500	50	Built-in load capacitors
Washable* Type (Magazine)				
CSB...D (190 - 374kHz)	Not Available	100	-----	Obsolete Part
CSB...J (375 - 699kHz)	CSB...J-CA01	500	50	
CSB...J (700 - 1250kHz)	CSB...J-CA01	1000	100	
Surface Mount (Taping)				
CSBF...J (430 - 500kHz)	CSBF...J-TC01	-----	1500	Washable*
CSKCC...E (400 - 600kHz)	CSKCC...E-TC01	-----		Obsolete Part
CSBF...J (700 - 1250kHz)	CSBF...J-TC01	-----	3000	Washable*
MHz Ceramic Resonators				
Leaded				
2-Lead Terminal Type				
CSA...MK(1.251 - 1.799MHz)	Not Available	500	-----	Obsolete Part
CSA...MG (1.80 - 2.44MHz)	CSA...MG-TF01	500	1000	Deemphasized Part
CSA...MG (2.45 - 6.30MHz)	CSA...MG-TF01	500	1500	Deemphasized Part
CSA...MTZ (6.31 - 13.00MHz)	CSA...MTZ-TF01	500	1500	Deemphasized Part
CSA...MXZ (13.01 - 60.00MHz)	CSA...MXZ-TF01	500	1500	Deemphasized Part
CSALS..M...X-B0 (16.00 - 70.00MHz)	CSTLS..M...X-A0	500	2000	Deemphasized Part
Built-in Load Capacitor Type				
CST...MG (1.80 - 2.44MHz)	CST...MG-TF01	500	1000	Deemphasized Part
CST...MGW (2.45 - 6.30MHz)	CST...MGW-TF01	500	1500	Deemphasized Part
CSTLS..M...G-B0 (2.00 - 3.39MHz)	CSTLS..M...G-A0	500	2000	Washable*
CSTS...MG (3.40 - 10.00MHz)	CSTS...MG-TZ	500	1500	Washable*
CST...MTW (6.31 - 13.00)	CST...MTW-TF01	500	1000	Standard from 10.01 - 13.00MHz
CST...MXW (13.01 - 60.00MHz)	CST...MXW-TF01	500	1000	Standard from 13.01 - 15.99MHz
CSTLS..M...X-B0 (16.00 - 70.00MHz)	CSTLS..M...X-A0	500	2000	Washable*
Surface Mount				
2-Lead Terminal Type				
CSAC...MGC (1.80 - 6.00MHz)	CSAC...MGC-TC	-----	1500	Deemphasized Part
CSAC...MGCM (1.80 - 6.00MHz)	CSAC...MGCM-TC	-----	1500	Deemphasized Part
CSACS...MT (6.01 - 13.00MHz)	CSACS...MT-TC	-----	1000	Deemphasized Part
CSACV...MTJ (6.01 - 13.00MHz)	CSACV...MTJ-TC20	-----	2000	Deemphasized Part
CSACS...MX (14.00 - 60.00MHz)	CSACS...MX-TC	-----	1000	Deemphasized Part
CSACV...MXJ (13.50 - 70.00MHz)	CSACV...MXJ-TC20	-----	2000	Deemphasized Part

Table 22. Piezo Products Taping List

CSACW...MX (20.01 - 70.00MHz)	CSACW...MX03-T	-----	3000	Deemphasized Part
Built-in Load Capacitor Type				
CSTC...MG (2.00 - 3.50MHz)	CSTC...MG-TC20	-----	2000	Obsolete Part
CSTCC...MG (2.00 - 10.00MHz)	CSTCC...MG-TC	-----	2000	Standard from 2.00 - 3.99, 8.00 - 10.00MHz
CSTCR...M...G-B0 (4.00 - 7.99MHz)	CSTCR...M...G-R0	-----	3000	
CSTCV...MTJ (10.01 - 13.00MHz)	CSTCV...MTJ-TC20	-----	2000	
CSTCS...MX (14.00 - 60.00MHz)	CSTCS...MX-TC	-----	1000	Deemphasized Part
CSTCV...MXJ (13.50 - 70.00MHz)	CSTCV...MXJ-TC20	-----	2000	
CSTCW...MX (20.01 - 70.00MHz)	CSTCW...MX03-T	-----	3000	
* Contact Murata for washing conditions ... represents the resonating frequency				
kHz Filters				
2nd IF Ladder Filters				
CFU...[]2	CFU...[]2-CA01	200	50	4 Elements
CFWS...[]	CFWS...[]-CA01	150	50	6 Elements
CFV...[]	CFV...[]-CA01	150	50	7 Elements
CFUM...[]	Not Available	250	-----	Miniature Size / 4 Elements
CFWM...[]	Not Available	150	-----	Miniature Size / 6 Elements
CFVM...[]	Not Available	300	-----	Miniature Size / 7 Elements
CFZM...[]	Not Available	150	-----	Miniature Size / 9 Elements
CFUS...[]Y	CFUS...[]Y-CA01	200	50	
CFWS...[]Y	Not Available	150	-----	
CFUM...[]Y	Not Available	250	-----	
CFWM...[]Y	Not Available	150	-----	
CFS...[]	Not Available	50	-----	Metal Case / 15 Elements
CFK...[]	Not Available	80	-----	Metal Case / 11 Elements
CFR...[]	Not Available	60	-----	Metal Case / 11 Elements
CFX...[]	Not Available	150	-----	Metal Case / 9 Elements
CFM...[]	Not Available	70	-----	Metal Case / 9 Elements
CFG...[]	Not Available	150	-----	Metal Case / 9 Elements
CFJ...K[]	Not Available	60	-----	Metal Case / 11 Elements
CFKR...[]I	Not Available	80	-----	Metal Case / 11 Elements / Flat GDT
CFL...[]G	Not Available	80	-----	Metal Case / 9 Elements / Flat GDT
CFUCG...[]	CFUCG...[]-TC	-----	450	SMD / 4 Elements
SFGCG...[]	SFGCG...[]-TC	-----	450	SMD / 4 Elements
SFPC...[]	SFPC...[]-TC01	-----	1000	SMD / 4 Elements
CFUCH...[]	CFUCH...[]-TC	-----	500	SMD / 4 Elements
CFZC...[]	CFZC...[]-TC	-----	350	SMD / 8 Elements
CFWC...[]	CFWC...[]-TC	-----	350	SMD / 6 Elements
... represents center frequency [] represents the bandwidth code (A, B, C, D, E, F, G, H, I, J)				
Discriminators				
CDB...C[]	CDB...C[]-CA01	500	50	
CDBM...C[]	CDBM...C[]-CA01	500	80	Miniature Version Of CDB
CDBC...CX[]	CDBC...CX[]-TC	-----	500	SMD
... represents center frequency [] represents IC indicator number				
MHz Filters				
SIF Filters				

Table 22. Piezo Products Taping List

SFE...MB	SFE...MB-TF21	500	1500	Discontinued
SFE...MC	SFE...MC-TF21	500	1500	
SFSL...MCB	Not Available	500	-----	
SFSL...MDB	Not Available	500	-----	
SFSL...MEB	Not Available	500	-----	
SFSH...MCB	SFSH...MCB-TF21	500	1500	
SFSH...MDB	SFSH...MDB-TF21	500	1500	
SFSH...MEB	SFSH...MEB-TF21	500	1500	
SFSRA...C	SFSRA...C-A0	500	2000	
SFSRA...D	SFSRA...D-A0	500	2000	
SFSRA...E	SFSRA...E-A0	500	2000	
SFT...MA	Not Available	250	1500	
SFSCC...MC	SFSCC...MC-TC10	-----	3000	
... represents center frequency				
Trap Filters				
TPS...MJ	TPS...MJ-TF23	500	1500	
TPS...MB	TPS...MB-TF21	500	1500	
TPS...MC	TPS...MC-TF21	500	1500	
TPS...MWA	TPS...MWA-TF21	500	1500	
TPSRA...B-B0	TPSRA...B-A0	500	2000	
TPSRA...C-B0	TPSRA...C-A0	500	2000	
TPWA...B	TPWA...B-TF21	500	1500	Double Trap
TPT...B	TPT...B-TF21	500	1500	Triple Trap
TPSC...MB	TPSC...MB-TC	500	2000	SMD
TPSC...MC	TPSC...MC-TC	500	2000	SMD
MKT...MA	MKT...MA-TF01	500	1500	High Frequency Trap
... represents center frequency				
Discriminators				
CDA...MC[]	CDA...MC[]-TF21	500	1500	
CDA...ME[]	CDA...ME[]-TF21	500	1500	
CDA...MG[]	CDA...MG[]-TF21	500	1500	
CDSL...MC[]K	Not Available	500	-----	
CDSL...ME[]K	Not Available	500	-----	
CDSH...MC[]K	CDSH...MC[]K-TF21	500	1500	
CDSH...ME[]K	CDSH...ME[]K-TF21	500	1500	
CDSC...MC[]	CDSC...MC[]-TC10	500	3000	
CDAC...MC[]	CDAC...MC[]-TC	-----	1000	SMD
CDAC...MG[]	CDAC...MG[]-TC	-----	1000	SMD
CDACV...MG[]	CDACV...MG[]-TC	-----	2000	SMD
... represents center frequency				
[] represents IC indicator number				
SAW Filters				
SAF...M[]80Z	SAF...M[]80Z-TF01	300	500	
SAF...M[]70Z	Not Available	300	-----	
SAF...M[]60Z	Not Available	300	-----	
SAF...M[]55Z	Not Available	300	-----	
SAF...M[]200Z	SAF...M[]200Z-TF01	300	500	
SAF...M[]220Z	SAF...M[]220Z-TF01	300	500	
SAFW...M[]80Z	SAFW...M[]80Z-TF01	300	450	
... represents center frequency				

Table 22. Piezo Products Taping List

[] represents type				
FM IF Filters				
SFE...MA5-[]	SFE...MA5-[]-TF21	500	1500	
SFE...MS2-[]	SFE...MS2-[]-TF21	500	1500	
SFE...MS3-[]	SFE...MS3-[]-TF21	500	1500	
SFE...MA19-[]	SFE...MA19-[]-TF21	500	1500	Wide Bandwidth Series
SFE...MA20-[]	SFE...MA20-[]-TF21	500	1500	
SFE...MA21-[]	SFE...MA21-[]-TF21	500	1500	
SFE...MA5A10-[]	SFE...MA5A10-[]-TF21	500	1500	Low Insertion Loss Series
SFE...MS2A10-[]	SFE...MS2A10-[]-TF21	500	1500	
SFE...MS3A10-[]	SFE...MS3A10-[]-TF21	500	1500	
SFE...MJA10-[]	SFE...MJA10-[]-TF21	500	1500	
SFE...MA5B10-[]	SFE...MA5B10-[]-TF21	500	1500	High Attenuation Series
SFE...MS2B10-[]	SFE...MS2B10-[]-TF21	500	1500	
SFE...MS3B10-[]	SFE...MS3B10-[]-TF21	500	1500	
SFE...MJB10-[]	SFE...MJB10-[]-TF21	500	1500	
SFE...MHB10-[]	SFE...MHB10-[]-TF21	500	1500	
SFE...MA5C10-[]	SFE...MA5C10-[]-TF21	500	1500	Low Profile Series
SFE...MS2C10-[]	SFE...MS2C10-[]-TF21	500	1500	
SFE...MS3C10-[]	SFE...MS3C10-[]-TF21	500	1500	
SFE...MJC10-[]	SFE...MJC10-[]-TF21	500	1500	
SFE...MHC10-[]	SFE...MHC10-[]-TF21	500	1500	
SFE...MA8-[]	SFE...MA8-[]-TF21	500	1500	GDT Controlled Series
SFE...MS2G-[]	SFE...MS2G-[]-TF21	500	1500	
SFE...MS3G-[]	SFE...MS3G-[]-TF21	500	1500	
SFE...MX-[]	SFE...MX-[]-TF21	500	1500	GDT Improved Series
SFE...MZ-[]	SFE...MZ-[]-TF21	500	1500	
SFE...ML-[]	SFE...ML-[]-TF21	500	1500	
SFE...MP-[]	SFE...MP-[]-TF21	500	1500	
SFE...MM-[]	SFE...MM-[]-TF21	500	1500	
SFE...MHY-[]	SFE...MHY-[]-TF21	500	1500	Narrow Bandwidth Type
SFE...MTE-[]	Not Available	500	-----	2nd Harmonic Filter
SFE...MVE-[]	Not Available	500	-----	2nd Harmonic Filter
SFE...MFP-[]	Not Available	500	-----	Super Narrow Bandwidth Type
SFT...MS3-[]	Not Available	500	-----	3 Element Series
SFT...MS2-[]	Not Available	500	-----	
SFT...MA5-[]	Not Available	500	-----	
SFECA...MA2-[]	SFECA...MA2-[]-TC	-----	2000	
SFECA...MA5-[]	SFECA...MA5-[]-TC	-----	2000	
SFECA...MS2-[]	SFECA...MS2-[]-TC	-----	2000	
SFECA...MS3-[]	SFECA...MS3-[]-TC	-----	2000	
SFECA...MJ-[]	SFECA...MJ-[]-TC	-----	2000	
SFECA...MA19-[]	SFECA...MA19-[]-TC	-----	2000	
SFECA...MA2S-[]	SFECA...MA2S-[]-TC	-----	2000	
SFECA...MA5S-[]	SFECA...MA5S-[]-TC	-----	2000	
SFECA...MS2S-[]	SFECA...MS2S-[]-TC	-----	2000	
SFECA...MS3S-[]	SFECA...MS3S-[]-TC	-----	2000	
SFECA...MJS-[]	SFECA...MJS-[]-TC	-----	2000	
SFECA...MJKS-[]	SFECA...MJKS-[]-TC	-----	2000	
SFECA...MA19S-[]	SFECA...MA19S-[]-TC	-----	2000	

Table 22. Piezo Products Taping List

SFECV...MA21S-[]	SFECV...MA21-[]-TC	-----	2000	Wide Bandwidth
SFECV...MHS-[]	SFECV...MH-[]-TC	-----	2000	
SFECV...MHKS-[]	SFECV...MHK-[]-TC	-----	2000	
SFECS...MA5-[]	SFECS...MA5-[]-TC	-----	2000	Miniature version of the SFECV
SFECS...MS2-[]	SFECS...MS2-[]-TC	-----	2000	Miniature version of the SFECV
SFECS...MS3-[]	SFECS...MS3-[]-TC	-----	2000	Miniature version of the SFECV
CFEC...M[*]	CFEC...M[*]-TC	-----	2000	
CFECV...M[*]	CFECV...M[*]-TC	-----	2000	GDT Controlled Version Of SFECV
CFECS...M[*]	CFECS...M[*]-TC	-----	2000	Miniature Version Of CFECV
... represents center frequency				
[] represents rank of center frequency code				
[*] represents type				
Buzzers				
External Drive Diaphragms				
7BB-12-9	Not Available	5120	-----	
7BB-15-6	Not Available	8000	-----	
7BB-20-3	Not Available	3000	-----	
7BB-20-6	Not Available	1800	-----	
7BB-27-3	Not Available	1500	-----	
7BB-27-3R5	Not Available	2400	-----	
7BB-27-4	Not Available	1500	-----	
7BB-35-3	Not Available	800	-----	
7BB-41-2	Not Available	400	-----	
7BB-50M-1	Not Available	600	-----	
7SB-20-7	Not Available	1800	-----	
7SB-27-5	Not Available	1500	-----	
7MB-15-11	Not Available		-----	
7MB-20-7	Not Available	1800	-----	
7MB-27-3	Not Available	1800	-----	
7MB-27-4	Not Available	3500	-----	
7NB-31R2-19R7DM-1	Not Available	1600	-----	
7NB-35-1	Not Available	1200	-----	
7NB-41-25DM-1	Not Available	1600	-----	
7BB-20-6A0	Not Available	600	-----	
7BB-27-4A0	Not Available	600	-----	
7BB-35-3A0	Not Available	400	-----	
7BB-41-2A0	Not Available	250	-----	
7SB-20-7A1	Not Available	1600	-----	
Self Drive Diaphragms				
7BB-20-6C	Not Available	1800	-----	
7BB-27-3C	Not Available	2400	-----	
7BB-27-4C	Not Available	1500	-----	
7BB-35-3C	Not Available	800	-----	
7BB-41-2C	Not Available	400	-----	
7SB-34R7-3C	Not Available	800	-----	
7SB-34R7-3C2	Not Available	800	-----	
7NB-27-2C	Not Available	3000	-----	
7NB-27-3C	Not Available	1800	-----	
7NB-27-4C	Not Available		-----	
7BB-20-6CA0	Not Available	600	-----	

Table 22. Piezo Products Taping List

7BB-27-4CA0	Not Available	600	-----	
7BB-35-3CA0	Not Available	400	-----	
7BB-41-2CA0	Not Available	250	-----	
External Drive Buzzers				
PKM17EW-2001	Not Available	250	-----	
PKM35-4A0	Not Available	500	-----	
PKM11-4A0	Not Available	400	-----	
PKM13EPY-4002	PKM13EPY-4002-TF01	330	500	
PKM17EPP-4001	Not Available	200	-----	
PKM22EPP-2001	Not Available	750	-----	
PKM22EPP-4001	Not Available	900	-----	
PKM22EPP-4005	Not Available	750	-----	
PKM22EPP-4007	Not Available	750	-----	
PKM22EP-2001	Not Available	360	-----	
PKM17EPT-4001	Not Available	180	-----	
PKM22EPT-2001	Not Available	300	-----	
PKM22EPT-4001	Not Available	300	-----	
PKMC16E-4000	PKMC16E-4000-TY	-----	1200	
Self Drive Buzzers				
PKM11-6A0	Not Available	400	-----	
PKM25-6A0	Not Available	630	-----	
PKM29-3A0	Not Available	90	-----	
PKM37-2A0	Not Available	56	-----	
PKM25SP-3701	Not Available	130	-----	
PKM24SP-3805	Not Available	360	-----	
PKM30SPT-2001	Not Available	70	-----	
PKM30SPT-2501	Not Available	70	-----	
Buzzers With Internal Circuitry				
PKB24SW-3301	Not Available	200	-----	
PKB6-5A0	Not Available	25	-----	
PKB5-3A0	Not Available	25	-----	
PKB24SPC-3601	Not Available	650	-----	
PKB8-4A0	Not Available	90	-----	
PKB30SPC-2001	Not Available	80	-----	
PKB30SPC-3001	Not Available	80	-----	
Ringers For Telephone Applications				
PKM34EW-1101C	Not Available	25	-----	
PKM34EW-1201C	Not Available	25	-----	
PKM44EW-1001C	Not Available	25	-----	
PKM44EP-0901	Not Available	160	-----	
PKM33EP-1201C	Not Available	300	-----	
Receivers For Telephone Applications				
PKD33EW-01R	Not Available	120	-----	
PKD22EW-01R	Not Available	300	-----	
PKD17-01R	Not Available		-----	
Speakers				
VSB41D25-07AR0	Not Available	100	-----	
VSB35EW-0701B	Not Available	160	-----	
VSB50EW-0301B	Not Available	80	-----	

Table 22. Piezo Products Taping List