

Operating and installation instructions Built-in vacuum drawer



To avoid the risk of accidents or damage to the appliance it is **essential** to read these instructions before it is installed and used for the first time.

Contents

Warning and Safety instructions	4
Caring for the environment	13
Guide to the appliance	14
Overview of the drawer	14
Controls and indicators	15
Accessories supplied	16
Cleaning for the first time	17
Operation	18
Important information for use	18
Tips	19
Using the vacuum settings	20
Using the sealing levels	21
Vacuuming and sealing bags	23
Sealing the bag early	24
Vacuum sealing preserving jars and jars with twist-off lids	25
Vacuuming sealing external containers	27
After use	30
Cancelling a vacuum sealing process	30
Cleaning and care	31
Cleaning the drawer front and glass lid	32
Cleaning the vacuum chamber and sealing bar	32
Cleaning the vacuum adapter	32
Cleaning the vacuum sealing bag support	32
Carrying out a drying cycle	33
Problem solving guide	34
Optional accessories	40
After sales service	41
Contact in case of malfunction	41
Data plate	41
Guarantee	41
Installation	42
Safety instructions for installation	42
Installation notes	43

Contents

Building-in dimensions	44
Installation in a tall or base unit.....	44
Combination appliance for niches with a height of 450 mm.....	45
Combination appliance for niches with a height of 590 mm.....	46
Side view	47
Connections and ventilation.....	48
Installation	49
Electrical connection.....	54

Warning and Safety instructions

This drawer complies with all current local and national safety requirements. Inappropriate use can, however, lead to personal injury and material damage.

Read the operating and installation instructions carefully before using the drawer. They contain important information on safety, installation, use and maintenance. This prevents both personal injury and damage to the drawer.

In accordance with standard IEC 60335-1, Miele expressly and strongly advises that you read and follow the instructions in the chapter on installing the drawer as well as the safety notes and warnings.

Miele cannot be held liable for injury or damage caused by non-compliance with these instructions.

Keep these operating and installation instructions in a safe place and pass them on to any future owner.

Correct application

- ▶ The drawer is intended for domestic use and use in other similar environments.
- ▶ The drawer is not intended for outdoor use.
- ▶ The drawer is only for domestic use to vacuum and seal food in vacuum bags intended for this purpose, to vacuum seal preserving jars, jars with twist-off lids and vacuum-proof containers made of plastic or stainless steel.
Any other use is not permitted.
- ▶ Never vacuum seal live food (e.g. mussels, seafood).
- ▶ People with reduced physical, sensory or mental capabilities, or lack of experience and knowledge who are not able to use the drawer safely on their own must be supervised whilst using it. They may only use it unsupervised if they have been shown how to use it safely and recognise and understand the consequences of incorrect operation.

Warning and Safety instructions

Safety with children

- ▶ Children under the age of 8 years must be kept away from the drawer unless they are constantly supervised.
- ▶ Children aged 8 and older may only use the drawer without supervision if they have been shown how to use it and are able to do so in a safe manner. Children must be able to understand and recognise the possible dangers caused by incorrect operation.
- ▶ Children must not be allowed to clean the drawer unsupervised.
- ▶ Please supervise children in the vicinity of the drawer, and do not let them play with it.
- ▶ The sealing bar becomes hot during operation. The weld seam of the vacuum bag is also heated to a very high temperature during the sealing process. Keep children away from the drawer until the sealing bar and the seam have cooled sufficiently that there is no longer any danger of burning.
- ▶ Danger of suffocation. Packaging, e.g. plastic wrappings, must be kept out of the reach of babies and children. Whilst playing, children could become entangled in packaging or pull it over their head and suffocate.

Technical safety

- ▶ Unauthorised installation, maintenance and repairs can cause considerable danger for the user. Installation, maintenance and repairs must only be carried out by a Miele authorised technician.
- ▶ A damaged drawer can be dangerous. Always check for visible signs of damage. Never use a damaged appliance.
- ▶ Pay attention to any damage or cracks to the glass lid or chamber seal. Damage to the glass lid can cause implosion. Never operate the drawer if the glass lid and/or the chamber seal is damaged.
- ▶ The drawer has an integrated vacuum pump which contains oil. To prevent oil from leaking out, the drawer must be transported and stored in a horizontal position only. Do not tilt the drawer and do not stand it up on its side.
The manufacturer's warranty will be invalidated if oil has leaked out of the appliance because it has not been transported or stored correctly.
- ▶ Reliable and safe operation of the drawer can only be assured if it has been connected to the mains electrical supply.
- ▶ The electrical safety of this drawer can only be guaranteed when correctly earthed. It is essential that this standard safety requirement is met. If in any doubt please have the electrical installation tested by a qualified electrician.
- ▶ The connection data (voltage and frequency) on the data plate of the drawer must match the mains electricity supply in order to avoid the risk of damage to the drawer. Compare this data before connecting the appliance. If in doubt, consult a suitably qualified electrician.
- ▶ Do not connect the drawer to the mains electrical supply by a multi-socket adapter or extension lead. These are a fire hazard and do not guarantee the required safety of the appliance.

Warning and Safety instructions

- ▶ For safety reasons, this drawer may only be used when it has been built in.
- ▶ This drawer must not be used in a non-stationary location (e.g. on a ship).
- ▶ Never open the casing of the drawer.
Touching or tampering with electrical connections or components and mechanical parts is highly dangerous to the user and can cause operational faults.
- ▶ Do not operate the drawer with wet hands or if you are in contact with water.
- ▶ While the appliance is under warranty, repairs should only be undertaken by a Miele authorised service technician. Otherwise the warranty is invalidated.
- ▶ Miele can only guarantee the safety of the appliance when genuine original Miele replacement parts are used. Faulty components must only be replaced by Miele spare parts.
- ▶ If the plug is removed from the connection cable or if the cable is supplied without a plug, the drawer must be connected to the electrical supply by a suitably qualified electrician.
- ▶ If the mains connection cable is damaged, it must be replaced with a special mains connection cable (see “Electrical connection” in the “Installation” chapter).
- ▶ If power is interrupted during vacuum sealing the vacuum in the chamber is retained and the glass lid cannot be opened. Do not under any circumstances try to force the glass lid open or use tools to open it. You will be able to open the lid when power has been restored.
- ▶ During installation, maintenance and repair work, the drawer must be disconnected from the mains electricity supply.

Warning and Safety instructions

► If the drawer is installed behind a furniture panel (e.g. a door), ensure that the door is never closed whilst the drawer is in use. Heat and moisture can build up behind a closed furniture panel and cause subsequent damage to the drawer, the housing unit and the floor. Do not close the door until the sealing bar and the drawer have cooled down completely.

Warning and Safety instructions

Correct use

- ▶ Danger of burning. The sealing bar gets hot during operation. The weld seam of the vacuum sealing bag is also heated to a very high temperature during the sealing process. Do not touch the sealing bar or the weld seam immediately after the vacuuming process.
- ▶ Fire hazard. Do not store any easily flammable substances and materials in the vicinity of the drawer.
- ▶ The telescopic runners can support a maximum load of 15 kg. Overloading or leaning or sitting on the drawer will damage the telescopic runners.
- ▶ Damage to the glass lid can cause implosion. Do not place any objects on the glass lid. Ensure that the glass lid cannot sustain damage from falling objects.
- ▶ Do not use the drawer or the glass lid as a working surface, a chopping surface or as a shelf.
- ▶ The drawer must be built in so that it can be pulled out completely and there is sufficient room to open the glass lid. This ensures that you can see into the vacuum chamber and avoid touching the sealing bar and weld seam and burning yourself.
- ▶ When vacuuming liquids, bubbles can form at lower temperatures which will cause a boiling impression. Steam can escape which can cause the drawer to malfunction.
For this reason only vacuum seal food (liquid or solid) when it has cooled. Follow the vacuuming process carefully and if necessary seal the bag early.
- ▶ Liquid getting inside the drawer and into the vacuum pump air intake valve can result in damage to the vacuum pump.
- ▶ Moisture in food or drinks can cause corrosion damage in the drawer. Do not use the drawer to store food or drinks.

Warning and Safety instructions

▶ Never insert the tubes attached to the drawer into any body orifices.

Vacuum sealing preserving jars and jars with twist-off lids in the closed vacuum sealing chamber:

▶ Danger of injury. Damage and cracks in jars or glass/twist-off lids can cause implosion.

Only vacuum jars and lids which are in perfect condition.

▶ Danger of injury. The high pressure during the vacuuming process causes the vacuum chamber and the glass lid on the drawer to deform slightly. Do not let preserving jars or jars with twist-off lids touch the drawer's glass lid during the vacuuming process as this can cause damage to the protective coating on the glass lid and cause it to implode.

Only vacuum seal preserving jars and jars with twist-off lids up to a maximum height of 8 cm in order to maintain a safety gap of at least 1 cm between the lid on the jar and the glass lid on the drawer.

Warning and Safety instructions

Cleaning and care

- ▶ Danger of electric shock. The steam from a steam cleaning appliance could reach live electrical components and cause a short circuit. Do not use a steam cleaner to clean the warming drawer.

Disposal of the packing material

The packaging is designed to protect the appliance from damage during transportation. The packaging materials used are selected from materials which are environmentally friendly for disposal and should be recycled.

Recycling the packaging reduces the use of raw materials in the manufacturing process and also reduces the amount of waste in landfill sites.

Disposal of your old appliance

Electrical and electronic appliances often contain valuable materials. They also contain materials which, if handled or disposed of incorrectly, could be potentially hazardous to human health and to the environment. They are, however, essential for the correct functioning of your appliance. Please do not therefore dispose of it with your household waste.

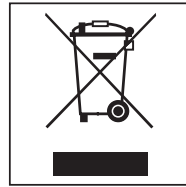

Please dispose of it at your local community waste collection / recycling centre or contact your Miele dealer for advice.

Ensure that it presents no danger to children while being stored for disposal.

Guide to the appliance

Overview of the drawer

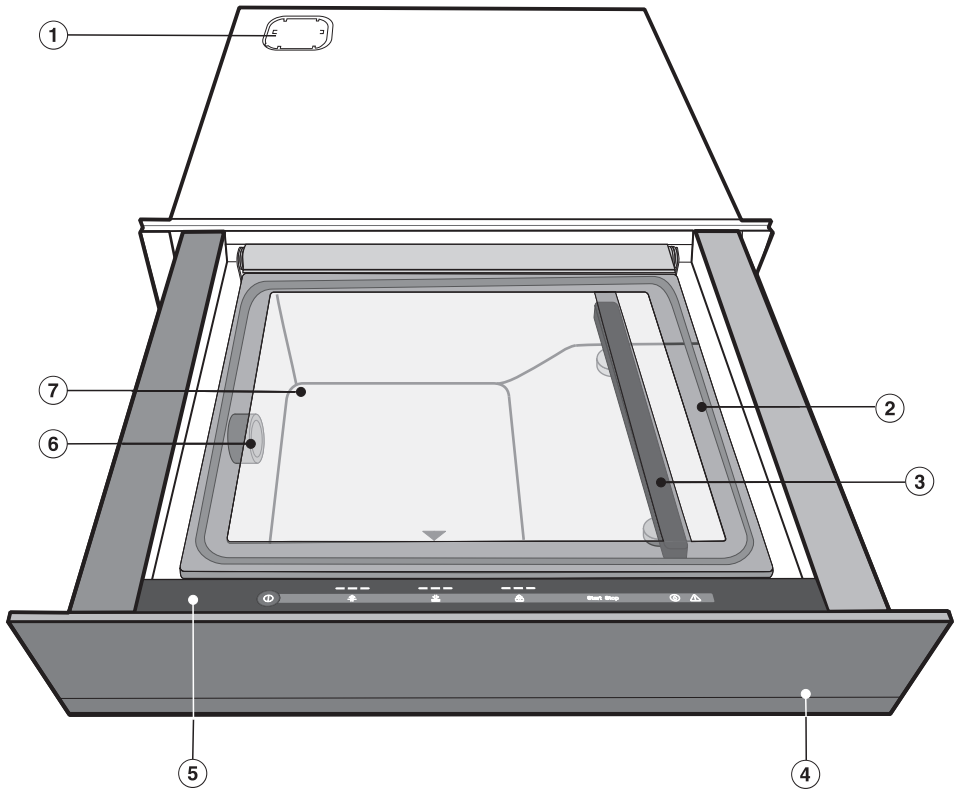

- ① Air filter cover (see “Installation”)
- ② Glass lid with chamber seal
Push down on the little black triangle to close the glass lid.
- ③ Sealing bar in the vacuum chamber and counterpressure bar on the underside of the glass lid
- ④ Drawer front with Push2open mechanism
The drawer can be opened and closed by lightly pressing the drawer front.
- ⑤ Controls and indicators
- ⑥ Vacuum pump air intake valve/Vacuum adapter connection
- ⑦ Vacuum chamber

Controls and indicators

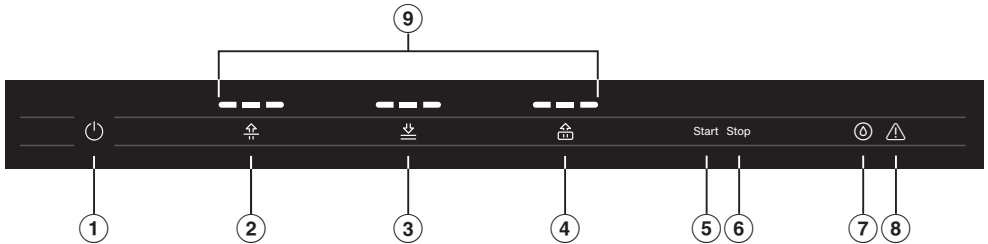

Sensor controls

- ① On/Off sensor control ⏻
For switching the drawer on/off
- ② Sensor control ⬆️⬆️
For setting the vacuum settings
- ③ Sensor control ⬇️
For setting the sealing level/sealing the bag early
- ④ Sensor control ⬆️⬆️
For setting the vacuum settings for external containers
- ⑤ Sensor control Start
For starting the vacuum-sealing process for external containers
- ⑥ Sensor control Stop
For cancelling the:
 - Vacuum-sealing process
 - Vacuum-sealing process for external containers
 - Sealing process
 - Drying cycle
- ⑦ Sensor control ⏸️
For displaying/for starting a drying cycle
(see “Cleaning and care – Carrying out a drying cycle”).

Indicator lights

- ⑧ Indicator light ⚠️
Indicates a warning
(see “Problem solving guide”)
- ⑨ Segment bar indicator lights
For displaying the:
 - Vacuum settings
 - Sealing level
 - Vacuum settings for external containers

Guide to the appliance

Accessories supplied

The accessories supplied with your appliance as well as a range of optional ones are available to order from your Miele dealer (see „Optional accessories“).

Vacuum adapter

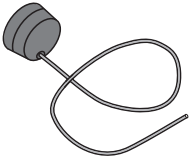

1 adapter for vacuum sealing external containers

Vacuum sealing bag support

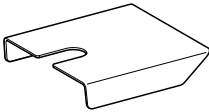

1 support for small bags

The vacuum sealing bags supplied are not suitable for use in steam ovens with pressure.

VB 1828 vacuum sealing bags

50 bags for storage and sous vide cooking of liquid and solid food
180 x 280 mm (W x H), D = 90 µm

VB 2435 vacuum sealing bags

50 bags for storage and sous vide cooking of liquid and solid food
240 x 350 mm (W x H), D = 90 µm

Cleaning for the first time

- Remove any protective wrapping and stickers.
- Do not remove stickers carrying safety or installation information or the data plate.

This makes it easier to perform servicing and repair work.

Cleaning the drawer for the first time

- Take all accessories out of the drawer.



Damage due to unsuitable cleaning agents.

The glass lid and the chamber seal become damaged or scratched.

Do not clean with any abrasive or acidic cleaning agents or sharp pointed objects.

- Clean the drawer inside and out with a clean sponge and a solution of hot water and washing-up liquid or a clean, damp microfibre cloth.
- After cleaning, wipe the surfaces dry using a soft cloth.

Operation

Important information for use

- Only vacuum seal food.
- Only use food that is fresh and in good condition.
- Ensure hygienic conditions and that food has not been out of the refrigerator too long, e.g. during transportation.
- Only vacuum seal food in suitable vacuum sealing bags, preserving jars and jars with twist-off lids (screw-top jars) or in vacuum-proof external containers.

We recommend that you use the vacuum sealing bags supplied (see "Optional accessories"). These are cold stable and boil-proof and therefore are suitable for storage in the refrigerator or freezer and for sous vide cooking of solid and liquid food.

- Only vacuum seal food that has cooled.
- Allow pre-cooked and grilled food to cool down at least to room temperature (approx. 20 °C) before vacuum sealing it.
Food that is not normally stored in the refrigerator, e.g. dried pasta or muesli can also be vacuum sealed at room temperature.
- If rinsing food with cold water, dry it before vacuum sealing to prevent water from collecting in the vacuum sealing bag or container.
- Only vacuum seal food in bags of a maximum size of 250 x 350 mm (sealed edge bags) or 240 x 350 mm (tubular bags).
- Use boil-proof bags if you want to cook food sous vide after vacuum sealing it.
- Select a suitable bag size for the size of the food. If the vacuum sealing bag is too big, too much air can remain inside. The bag can be cut to fit the size of the food.
- If you want to vacuum seal several types of food in one bag, place the food evenly side by side in the bag.
- Fill the vacuum sealing bag to a maximum of $\frac{2}{3}$ with solid food or $\frac{1}{3}$ with liquid.
- For a perfect weld seam, make sure that the edge of the bag is dry and grease-free in the area of the seam.
- Position the open edge of the bag parallel to the sealing bar so that the edge protrudes over the sealing bar by approx. 2 cm.
- Take care not to cover the vacuum pump air intake valve with the bag.
- Vacuum sealing bags are for single use only.
- Place food that is suitable for cooling in the refrigerator or freezer after vacuum sealing it.
- When vacuum sealing food in preserving jars and jars with twist-off lids, make sure that the jars and the lids are clean and in good condition.

 Danger of injury caused by implosion.

Damage to the glass lid can cause implosion.

Preserving jars and jars with twist-off lids must only be vacuum sealed in the closed vacuum chamber.

- To guarantee the minimum gap of 1 cm to the glass lid of the drawer, the jars must not be taller than 8 cm. Before vacuum sealing, make sure that jars do not exceed the maximum permitted height.

Tips

- Freeze liquids before vacuum sealing them. You can then fill the bag $\frac{2}{3}$ full.
- Fold the edges of the vacuum sealing bag outwards for filling. This will give you clean, perfect seams.
- If you are unsure whether food such as berries or crisps will lose its shape during vacuum sealing, start with the lowest vacuum setting.

Operation

Using the vacuum settings

There are 3 vacuum sealing settings.

The higher the vacuum setting selected, the greater the vacuum.

Vacuum settings	Intended use
■ □ □	<p>Packaging, portioning and storing</p> <p>Suitable for</p> <ul style="list-style-type: none">- Food that is prone to squashing, e.g. lettuce, berries or crisps- Preserving jars and jars with twist-off lids (screw cap lids) with liquid contents, e.g. stock or pickled vegetables
■ ■ □	<p>Marinating, tenderising, sous vide cooking and freezing</p> <p>Suitable for</p> <ul style="list-style-type: none">- Food that is prone to squashing, e.g. tender fish fillets- Sauces and food with a high liquid content (> 50 g), e.g. ragout, curry- Preserving jars and jars with twist-off lids (screw cap lids) with more solid or dry contents e.g. jam, pesto or cake
■ ■ ■	<p>Sous vide cooking, freezing and storage</p> <p>Suitable for</p> <ul style="list-style-type: none">- Meat and more solid food, e.g. potatoes, carrots- Hard cheese (storage)- Food with a low liquid content (≤ 50 g), such as meat seasoned with a herb oil

Using the sealing levels

There are 3 levels for sealing vacuum bags.

The sealing level to select depends on the material thickness of the bag: the stronger the bag, the higher the sealing level.

Level 3 is recommended for the vacuum sealing bags supplied.

Tip: The sealing bar will get progressively hotter when carrying out a number of consecutive vacuuming processes. You can use a lower sealing level after sealing a few bags.

Operation

 Danger of injury caused by implosion.

Damage to the glass lid can cause implosion.

Do not under any circumstances use the drawer if the glass lid is damaged.

 Malfunction due to dirty and/or covered sensor controls.

The sensor controls do not react or unintentional switching procedures result, perhaps even the automatic deactivation of the drawer.

Keep the sensor controls and indicators clean.

Do not place anything over the sensor controls or indicators.



 Damage caused by liquids.



Liquid getting into the vacuum pump air intake valve during a vacuuming process can result in damage to the vacuum pump.

Fill the vacuum sealing bag with liquid to a maximum of $\frac{1}{3}$.

Vacuumping and sealing bags

- Fill the vacuum sealing bag.
- Open the drawer and the glass lid.
- Place the vacuum sealing bag in the vacuum chamber so that the open end of the bag lies across the sealing bar. Ensure that the edge of the bag is positioned centrally and crease-free on the sealing bar.
- If a bag is too small and slips into the vacuum chamber, place the vacuum sealing bag support under it.
- Switch the drawer on with the ① On/Off sensor control.

The segment bar indicator lights above the  and  sensor controls light up.

- Touch the  sensor control repeatedly until the segment bar indicator light for the required vacuum setting lights up.
- Touch the  sensor control repeatedly until the segment bar indicator light for the required sealing level lights up.
- Close the glass lid and press it down lightly.

Tip: Press the small black triangle to close the glass lid.

The vacuum sealing process will start. The **start** sensor control goes out and the **stop** sensor control lights up.

The following occurrences during the process are normal and do not indicate a functional or appliance fault:

- The bag inflates, before enveloping the food being vacuum sealed.
- Bubbles form in the liquid, creating the impression that it is boiling.

If you notice during the vacuuming process that liquids are threatening to spill out, you can end the process and seal the bag early (see “Operation – Sealing the bag early”).

Operation

After the vacuuming process

A signal sounds.

- Open the glass lid.

 Danger of burning due to hot surfaces.

The sealing bar and weld seam are hot.

Do not touch the sealing bar or the weld seam immediately after the vacuuming process.

- Remove the vacuum sealing bag from the vacuum chamber.

Before starting a new vacuuming process, check that the vacuum chamber and the sealing bar are clean and dry.

Remove any soiling or liquid residues if necessary.

Sealing the bag early

You can end the vacuuming process before reaching the selected vacuum settings and seal the bag early.

- Touch the  sensor control.

The vacuuming process stops. After a few seconds the bag will be sealed.

Successful sealing of the bag is only possible when there is a minimum vacuum (vacuum setting 1) in the chamber.

Touch the  sensor control again if the required vacuum setting has not yet been reached. For technical reasons, a few seconds will elapse before the bag is sealed.

 Danger of injury caused by implosion.

Damage and cracks in jars or glass/ twist-off lids can cause implosion.

Only vacuum jars and lids which are in perfect condition.

Only vacuum jars on vacuum setting 1 or 2.



 Damage caused by deformation of glass lids.



The glass lid may become deformed due to the negative pressure that occurs.

Only vacuum seal jars up to a maximum height of 8 cm in order to maintain a safety gap of at least 1 cm between the lid on the jar and the glass lid on the drawer.

Vacuum sealing preserving jars and jars with twist-off lids

- Close the jar with its appropriate lid and rubber seal or with the twist-off lid.
- Open the drawer and the glass lid.
- Place the jar in the vacuum chamber.
- Switch the drawer on with the  On/Off sensor control.

The segment bar indicator lights above the  and  sensor controls light up.

- Touch the  sensor control repeatedly until the segment bar indicator light for vacuum setting 1 or 2 lights up.
- Touch the  sensor control repeatedly until the segment bar indicator light for sealing level 1 lights up.
- Close the glass lid and press it down lightly.

Tip: Press the small black triangle to close the glass lid.

The vacuum sealing process will start. The Start sensor control goes out and the Stop sensor control lights up.

Operation

After the vacuuming process

A signal sounds.

- Open the glass lid.

 Danger of burning due to hot surfaces.

The sealing bar is hot.

Do not touch the sealing bar immediately after the vacuuming process.

- Remove the jar from the vacuum chamber.

Before starting a new vacuuming process, check that the vacuum chamber and the sealing bar are clean and dry.

Remove any soiling or liquid residues if necessary.

 Danger of injury caused by implosion.

External glass containers can implode during vacuuming. Only use vacuum-proof containers made of plastic or stainless steel.

We recommend caso[®] container sets if you wish to use external containers. These containers can be connected to the drawer using the vacuum adapter supplied.

Vacuum sealing containers with a capacity of 700 ml can be damaged during the vacuum sealing process. Use only vacuum settings 1 and 2 when vacuum sealing these containers.

Vacuuming sealing external containers

The process for vacuum sealing a container from the caso[®] vacuum sealing container set is described below.

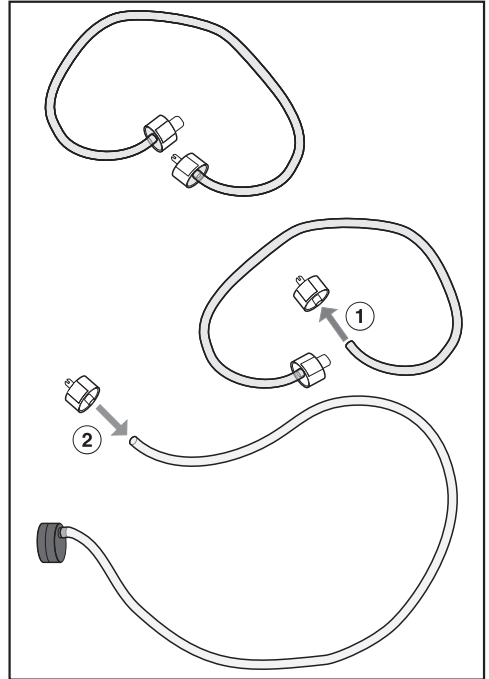



- Prepare the vacuum adapter: Detach the container lid connector (smaller diameter) ① from the container set connecting tube.
- Attach the connector to the end of the vacuum adapter tube ②. For a secure grip, make sure that the end of the tube is pushed at least 0.5 cm over the opening on the connector.
- Fill the container to a maximum of 3 cm below the rim.

Operation

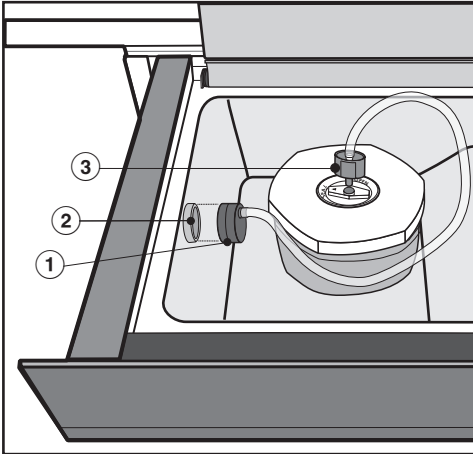



- Place the lid on the container and press it down.
- Open the drawer and the glass lid.







- Place the vacuum adapter ① over the vacuum pump air intake valve ②.
- Attach the connector ③ to the container lid. Make sure that the closure of the lid is turned to “SEAL” (closed).
- Switch the drawer on with the ① On/Off sensor control.

The segment bar indicator lights above the  and  sensor controls light up.

- Touch the  sensor control.

The segment bar indicator lights above the  and  sensor controls go out. The segment bar indicator lights above the  and  sensor controls light up.

- Touch the  sensor control repeatedly until the segment bar indicator light for the required vacuum setting lights up.
- Touch the  sensor control.

The vacuum sealing process will start. The  sensor control goes out and the  sensor control lights up.

Leave the glass lid of the drawer open for the entire duration of the vacuum sealing process.

If an excessive amount of bubbles form, you can cancel the vacuuming process by pressing the  sensor control (see “Operation – Cancelling the vacuum sealing process”).

After the vacuum sealing process

A signal sounds.

- Detach the connector from the container lid. Make sure that the closure of the lid is still turned to “SEAL” (closed).
- Remove the vacuum adapter from the vacuum pump air intake valve.

Before starting a new vacuuming process, check that the vacuum adapter, the tube and the vacuum chamber are clean and dry.

Remove any soiling or liquid residues if necessary.

Operation

After use

- Switch off the drawer with the ① On/Off sensor control.
- Clean and dry the drawer and any accessories as described in “Cleaning and care”.
- Do not close the glass lid until the vacuum chamber is completely dry.
- Close the drawer.

The last vacuum setting and sealing level selected is automatically activated the next time the drawer is switched on, and this is shown in the control field.

Cancelling a vacuum sealing process

You can cancel a vacuum sealing process at any time, e.g. if you notice during the process that the edge of the bag is not positioned correctly or that the closure on the container lid is not pointing to “SEAL” (closed).

Please note that when vacuum sealing bags, if the vacuum sealing process is cancelled, the bag will not be sealed.

- Touch the stop sensor control.

The vacuum sealing process stops.

 Danger of injury due to electric shock.

The steam from a steam cleaning appliance could reach live electrical components and cause a short circuit.

Do not use a steam cleaner to clean the drawer.

 Danger of burning due to hot surfaces.

The sealing bar is hot straight after a vacuuming process.

Allow the sealing bar to cool before cleaning it.

All surfaces could be discoloured or damaged if unsuitable cleaning agents are used. Use only domestic washing-up liquid to clean the drawer.

All surfaces are susceptible to scratching. Scratches on glass can in some circumstances lead to breakage.

Remove all cleaning agent residues immediately.

If soiling is left on for any length of time, it may become impossible to remove.

Surfaces may suffer discolouration or damage.

It is therefore best to remove any soiling immediately.

- Switch the drawer off to clean it.
- The drawer and accessories should be cleaned and dried thoroughly after each use.
- Do not close the glass lid until the vacuum chamber is completely dry.

Unsuitable cleaning agents

To avoid damaging the surfaces of the appliance, do not use:

- Cleaning agents containing soda, ammonia, acids or chlorides
- Cleaning agents containing descaling agents
- Abrasive cleaning agents, e.g. powder cleaners and cream cleaners
- Cleaning agents containing solvents
- Stainless steel cleaners
- Cleaning agents for ceramic glass hobs
- Dishwasher cleaner
- Oven cleaners or sprays
- Hard, abrasive sponges and brushes, e.g. pot scourers
- Sharp metal scrapers

Cleaning and care

Cleaning the drawer front and glass lid

- Remove soiling and fingerprints with a standard domestic glass cleaner or with a clean, damp microfibre cloth.
- After cleaning, wipe the surfaces dry using a soft cloth.

Cleaning the vacuum chamber and sealing bar

 **Damage caused by liquids.**
Liquid getting into the vacuum pump air intake valve can result in damage to the vacuum pump.
Take care that liquids do not get into the air intake valve.

Tip: To make cleaning easier, the sealing bar can be lifted off.

- Remove light soiling immediately using a solution of hot water and washing-up liquid applied with a clean sponge or use a clean, damp microfibre cloth.
- Remove any residual cleaning agent with a little clean water.
- After cleaning, wipe the surfaces dry using a soft cloth.

Cleaning the vacuum adapter



- Clean the vacuum adapter with a clean sponge and a solution of hot water and washing-up liquid or a clean, damp microfibre cloth.
- Then dry the vacuum adapter with a cloth.
- Do not use the vacuum adapter again until it is completely dry.

Cleaning the vacuum sealing bag support

- Clean the vacuum sealing bag support with a clean sponge cloth, washing-up liquid and warm water or with a clean, damp microfibre cloth.
- Then dry the vacuum sealing bag support using a cloth.
- Do not use the vacuum sealing bag support again until it is completely dry.

Carrying out a drying cycle

When food is vacuum sealed, moisture gets into the oil circulation system in the vacuum pump. To remove the moisture, it is necessary to run a drying cycle after a particular operating time.

The  sensor control on the control field of the drawer lights up yellow when a drying cycle needs to be carried out. The sensor control lights up yellow and you can still run another 10 vacuum sealing processes. When the  sensor control lights up red, the drying cycle must be carried out. The drawer will lock after the last remaining use and cannot be used again until drying has been carried out.

We recommend carrying out a drying cycle before the drawer locks out.

The whole drying cycle lasts for a maximum of 20 minutes.

When carrying out the drying cycle, the vacuum chamber must be empty and free of liquid residues.

Clean and dry the vacuum chamber as necessary.

- Touch the  sensor control.
- Close the glass lid.

The drying cycle starts. The  sensor control will flash yellow throughout the entire duration.

You can cancel the drying cycle with the  sensor control. If a drying cycle is cancelled, it must be repeated after the remaining vacuum sealing processes have elapsed or when the drawer is switched on again.

When the drying cycle has finished, a signal sounds and the  sensor control goes out. You can now use the drawer again as usual.

The last selected vacuum setting and sealing level are displayed on the control field.

Problem solving guide

Many malfunctions and faults that can occur in daily operation can be easily remedied. Time and money will be saved because a service call will not be needed.

The following guide may help you to find the reason for a malfunction or a fault, and to correct it.

Issue	Cause and remedy
The drawer will not open.	The safety screws on the back of the drawer have not been removed. ■ Contact your Miele dealer.
The drawer cannot be switched on.	The appliance is not correctly plugged in and switched on at the mains socket. ■ Insert the plug and switch on at the socket.
	The fuse is defective or has tripped. ■ Reset the trip switch in the mains fuse box (minimum fuse rating - see data plate). If, after resetting the trip switch or replacing the fuse in the mains fuse box and switching the drawer back on, the drawer will still not operate, contact a qualified electrician or your Miele dealer.
There was a loud bang during operation.	The transit device has not been removed and the air filter has not been fitted. ■ Contact your Miele dealer.
The drawer has switched itself off.	The drawer will switch itself off automatically to save energy if no other action is taken within a certain time frame after switching it on or after the end of a vacuuming process. ■ Switch the drawer back on.
The sensor controls are not reacting to touch.	Foreign objects, soiling or liquid residues have got onto the control panel. ■ Remove the objects and/or clean and dry the control panel.

Problem solving guide

Issue	Cause and remedy
<p>The vacuuming process takes longer than expected.</p>	<p>The oil in the vacuum pump has become extremely hot.</p> <ul style="list-style-type: none"> ■ Leave the drawer to cool for an hour before starting another vacuuming process. ■ When carrying out a number of consecutive vacuuming processes, wait a minimum of 2 minutes between each process to prevent the oil from overheating again.
<p>The vacuum sealing bag was not sealed in time.</p>	<p>The required vacuum (vacuum setting 1) for sealing a bag was not achieved.</p> <ul style="list-style-type: none"> ■ Touch the $\underline{\text{V}}$ sensor control again or repeatedly until the vacuuming process ends and the bag is sealed.
<p>All the sensor controls have gone out. The glass lid will not open.</p>	<p>There was an interruption to the power supply during the vacuuming process. The vacuum chamber is still under pressure so the glass lid cannot be opened.</p> <div style="border: 1px solid gray; padding: 5px; margin: 10px 0;"> <p>Damage to the drawer. Do not in any circumstances try to force the glass lid open or use tools to open it.</p> </div> <ul style="list-style-type: none"> ■ When the power supply is restored, the glass lid can be opened again after initialisation (all sensor controls and indicators light up). ■ Start the vacuuming process again if necessary.
<p>There is still too much air in the bag at the end of the vacuuming process.</p>	<p>The vacuum level was too low.</p> <ul style="list-style-type: none"> ■ Start the vacuuming process again with a new bag and a higher vacuum level. <p>The vacuum sealing bag is too big for the food to be vacuumed.</p> <ul style="list-style-type: none"> ■ Use a new smaller bag or cut a larger bag to fit the size of the food. ■ Start the vacuuming process again, with a higher vacuum level if necessary.
<p>After several consecutive vacuuming processes the weld seam is faulty/not properly sealed.</p>	<p>The sealing bar has overheated.</p> <ul style="list-style-type: none"> ■ Wait a minimum of 2 minutes between individual vacuuming processes to avoid the sealing bar overheating again.



Problem solving guide

Issue	Cause and remedy
<p>The edge of the bag is not completely sealed.</p>	<p>The edge of the bag was not positioned centrally along the sealing bar or has slipped.</p> <ul style="list-style-type: none"> ■ Place the edge of the bag centrally along the sealing bar. Make sure that the edge of the bag is parallel to the sealing bar and protrudes over it by approx. 2 cm. ■ If the vacuum sealing bag is too small, place it on the vacuum sealing bag support.
	<p>The vacuum sealing bag is wider than 25 cm.</p> <ul style="list-style-type: none"> ■ Use vacuum sealing bags with a maximum width of 25 cm.
<p>The seal was not strong enough and has opened.</p>	<p>The edge of the bag is dirty (inside and out). For a perfect weld seam the edge of the bag must be dry and grease-free in the area of the seam.</p> <ul style="list-style-type: none"> ■ Fold the edges of the vacuum sealing bag outwards for filling. This will give you a clean, perfect weld seam.
	<p>The edge of the bag was not positioned smoothly and without creases on the sealing bar.</p> <ul style="list-style-type: none"> ■ Position the bag smoothly and without creases along the sealing bar.
	<p>The sealing level was too low.</p> <ul style="list-style-type: none"> ■ Start the vacuuming process again with a new vacuum sealing bag and select a higher sealing level.
	<p>The rubber on the counterpressure bar is not evenly fitted.</p> <ul style="list-style-type: none"> ■ Flatten the rubber.
	<p>The sealing bar and/or the counterpressure bar is damaged.</p> <ul style="list-style-type: none"> ■ Call Miele to have it replaced.

Problem solving guide

Issue	Cause and remedy
<p>The bag is not maintaining the vacuum although the weld seam is intact.</p>	<p>The vacuum sealing bag has been damaged by sharp pointed objects, e.g. pointed pasta shapes or a bone.</p> <ul style="list-style-type: none"> ■ Start the vacuuming process again with a new vacuum sealing bag, on a lower vacuum level if necessary. ■ Use an external container if possible.
<p>The weld seam is defective or not properly sealed in one or more places.</p>	<p>The sealing bar and/or counterpressure bar are dirty or there are liquid residues on the sealing bar.</p> <ul style="list-style-type: none"> ■ Clean and dry the sealing bar and/or counterpressure bar. <p>The rubber on the counterpressure bar is not evenly fitted.</p> <ul style="list-style-type: none"> ■ Flatten the rubber. <p>The edge of the bag is dirty (inside and out). For a perfect weld seam the edge of the bag must be dry and grease-free in the area of the seam.</p> <ul style="list-style-type: none"> ■ Fold the edges of the vacuum sealing bag outwards for filling. This will give you a clean, perfect weld seam. <p>The edge of the bag was not positioned smoothly and without creases on the sealing bar.</p> <ul style="list-style-type: none"> ■ Position the bag smoothly and without creases along the sealing bar.
<p>The ④ sensor is lit up even though a drying cycle has been carried out. The drawer cannot be used.</p>	<p>The drying cycle failed to remove all of the moisture from the oil circulation system in the vacuum pump. The drawer is locked and cannot be used for 1 hour.</p> <ul style="list-style-type: none"> ■ Wait for 1 hour and then carry out another drying cycle (see “Cleaning and care – Carrying out a drying cycle”). Ensure that the vacuum chamber is free of liquid residues.
<p>The ④ sensor lights up yellow. The vacuum is less than usual.</p>	<p>During the food evacuation process, moisture ingress into the oil circulation system in the vacuum pump has occurred. This can impair the performance of the vacuum levels.</p> <ul style="list-style-type: none"> ■ Carry out a drying cycle (see “Cleaning and care – Carrying out a drying cycle”).

Problem solving guide

Issue	Cause and remedy
<p>The  sensor button lights up red. A vacuuming process cannot be started.</p>	<p>During the food evacuation process, moisture ingress into the oil circulation system in the vacuum pump has occurred. If the  sensor lights up red, the drawer is locked for further use.</p> <ul style="list-style-type: none"> ■ Carry out a drying cycle (see “Cleaning and care – Carrying out a drying cycle”).
<p>There is a film of oil on the glass lid and in the drawer.</p>	<p>The oil in the vacuum pump has become extremely hot.</p> <ul style="list-style-type: none"> ■ Clean the drawer and leave it to cool down for 1 hour before starting another vacuuming process. ■ When carrying out a number of consecutive vacuuming processes, wait a minimum of 2 minutes between each process to prevent the oil from overheating again. ■ If the problem occurs again, contact your Miele dealer.
<p>The vacuuming process is cancelled after 2 minutes. A signal sounds and the  symbol lights up red.</p>	<p>The required final vacuum could not be achieved.</p> <ul style="list-style-type: none"> ■ Switch the drawer off and back on again. ■ Start the vacuuming process again with lower vacuum settings if necessary. <p>After intensive use of the drawer, the oil in the vacuum pump has become extremely hot.</p> <ul style="list-style-type: none"> ■ Leave the drawer to cool for an hour before starting another vacuuming process. ■ When carrying out a number of consecutive vacuuming processes, wait for at least 2 minutes between each process. This prevents the oil from overheating again.

Problem solving guide

Issue	Cause and remedy
<p>The vacuuming process is cancelled after 5 seconds. An acoustic tone sounds and the  symbol lights up red.</p>	<p>The glass lid is not sitting evenly. There is an object, e.g. the edge of a bag, or some soiling on the surface of the chamber seal.</p> <ul style="list-style-type: none"> ■ Remove the obstruction and/or the soiling. ■ Close the glass lid and press it down lightly for approx. 5 seconds. <p>The chamber seal is not fitted correctly.</p> <ul style="list-style-type: none"> ■ Press the chamber seal in all the way round to make sure it is fitted evenly. <p>The chamber seal is damaged, e.g. cracks can be seen.</p> <ul style="list-style-type: none"> ■ Call your Miele dealer to replace it.
<p>Abrasion marks on the top edge of the front panel.</p>	<p>Installing or removing an appliance above the drawer has caused abrasion marks.</p> <ul style="list-style-type: none"> ■ Carefully remove the abrasion marks by rubbing the top edge with the abrasive side of a standard scouring pad.

Optional accessories

Miele offer a comprehensive range of useful accessories as well as cleaning and conditioning products for your Miele appliances.

These can be ordered from your Miele dealer (see end of this booklet for contact details).

Vacuum sealing bags

VB 1828 (pack of 50)

For storing and sous vide cooking of liquid and solid food
180 x 280 mm (W x H), D = 90 µm

VB 2435 (pack of 50)

For storing and sous vide cooking of liquid and solid food
240 x 350 mm (W x H), D = 90 µm

Cleaning and care products

Microfibre cloth

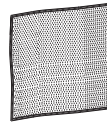

Removes finger marks and light soiling

Contact in case of malfunction

In the event of any faults which you cannot remedy yourself, please contact your Miele dealer.

Contact details for your Miele dealer are given at the end of this document.

Please note that telephone calls may be monitored and recorded for training purposes and that a call-out charge will be applied to service visits where the problem could have been resolved as described in this booklet.

Please quote the model and serial number of your appliance when contacting your Miele dealer. This information can be found on the data plate.

Data plate

The data plate is located here:

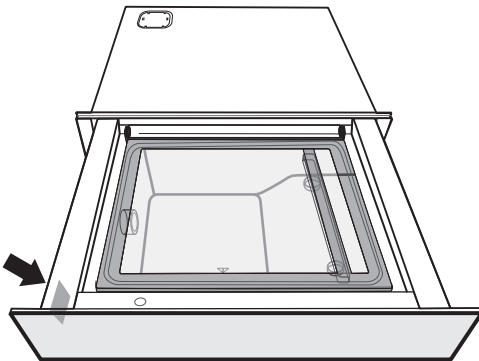

Guarantee

For information on the appliance guarantee specific to your country please contact your Miele dealer. See end of this booklet for contact details.

Installation

Safety instructions for installation



Risk of damage from incorrect installation.

Incorrect installation can cause damage to the drawer and/or the combination appliance.

The appliance must only be installed by a qualified person.

▶ Before connecting the drawer to the mains supply, ensure that the connection data on the data plate (voltage and frequency) match the mains electricity supply.

This data must correspond in order to avoid the risk of damage to the drawer. Consult a qualified electrician if in any doubt.

▶ The socket and on-off switch should be easily accessible after the drawer has been installed.

▶ The drawer may only be built in in combination with those appliances quoted by Miele as being suitable. Miele cannot guarantee trouble-free operation if the appliance is operated in combination with appliances other than those quoted by Miele as being suitable.

▶ The base on which the drawer and the combination appliance are fitted must be fixed in place and must support the weight of both appliances.

▶ When building in the combination appliance, it is essential to follow the instructions given in the operating and installation instructions supplied with the combination appliance.

▶ The drawer must be installed in such a way that

- you can see into the vacuum chamber. This helps to avoid scalding and burns from touching the hot sealing bar or weld seam.
- there is enough space for the drawer to be pulled out fully and for opening the glass lid.

Installation notes

The drawer can be used in combination with the following Miele built-in appliances:

- all ovens with an appliance front width of 595 mm
- all steam ovens with an appliance front width of 595 mm
- all coffee machines with an appliance front width of 595 mm
- all microwaves with an appliance front width of 595 mm
- the Dialog oven with an appliance front width of 595 mm

When building in the drawer with a combination appliance, the combination appliance is placed on top of the drawer without the need for an interim shelf.

Installation

Building-in dimensions

All dimensions are given in mm.

Installation in a tall or base unit

The furniture housing unit must not have a back panel fitted behind the building-in niche.

If the drawer is to be installed in a base unit underneath a hob, please also observe the installation instructions for the hob as well as the building-in depth required for the hob.

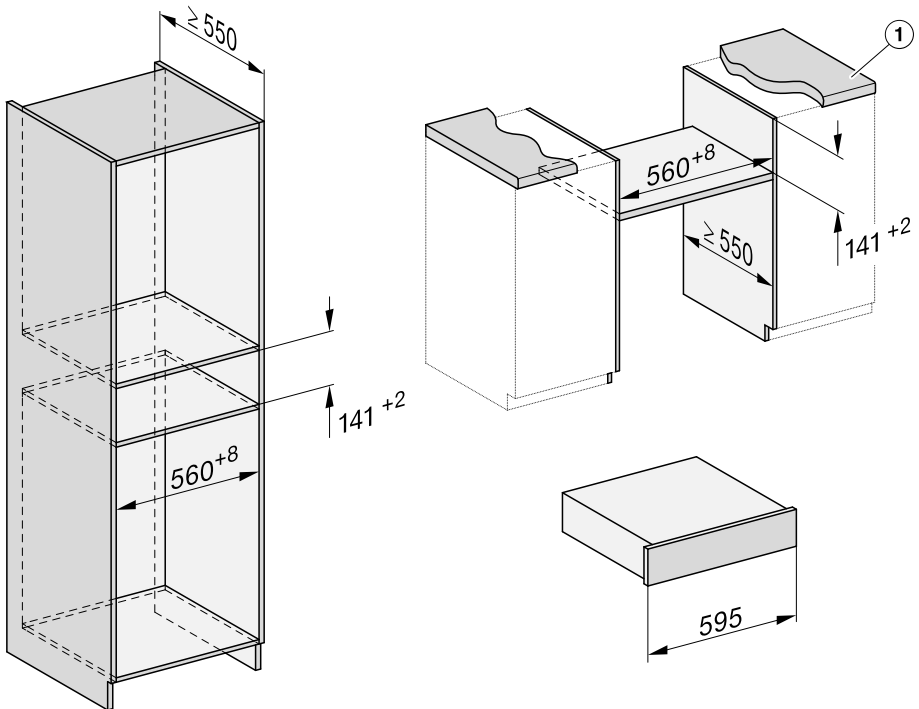

① Worktop protrusion ≤ 29 mm

Combination appliance for niches with a height of 450 mm

The furniture housing unit must not have a back panel fitted behind the building-in niche.

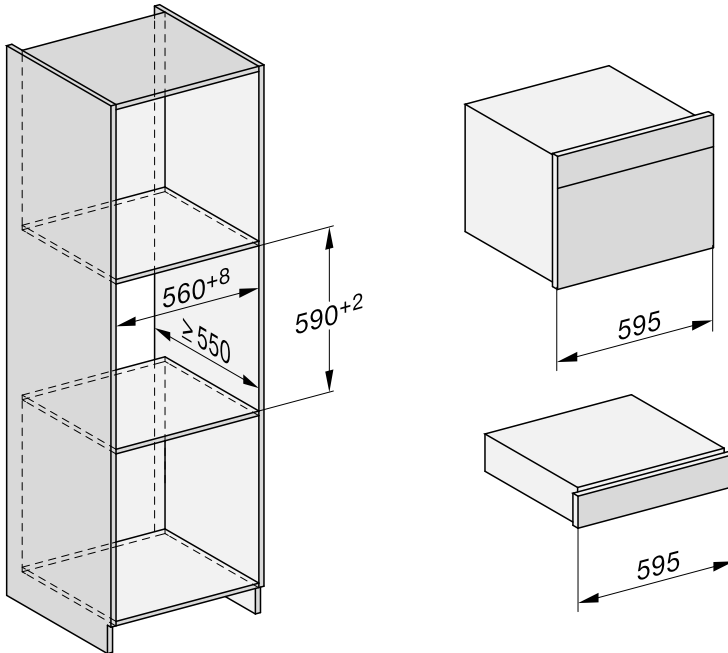

Installation

Combination appliance for niches with a height of 590 mm

The furniture housing unit must not have a back panel fitted behind the building-in niche.

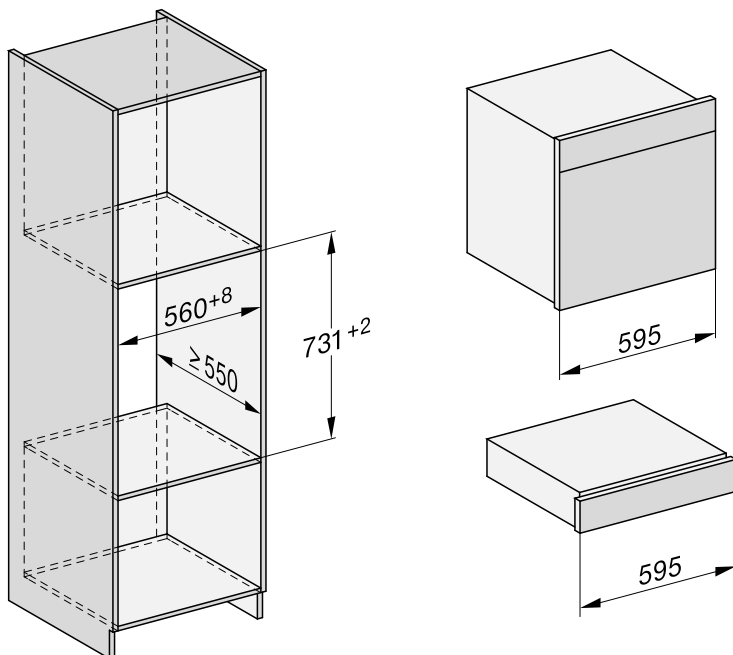

Side view

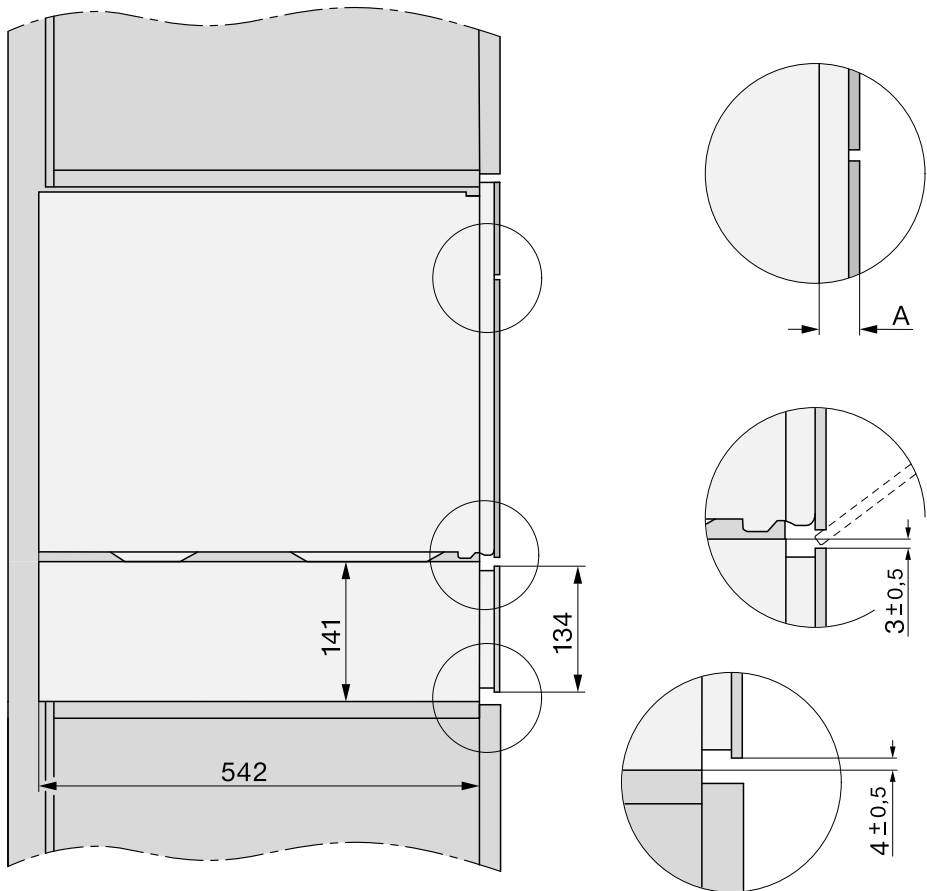

- A** EVS 7010: 22 mm
EVS 7110: 23.3 mm

Installation

Connections and ventilation

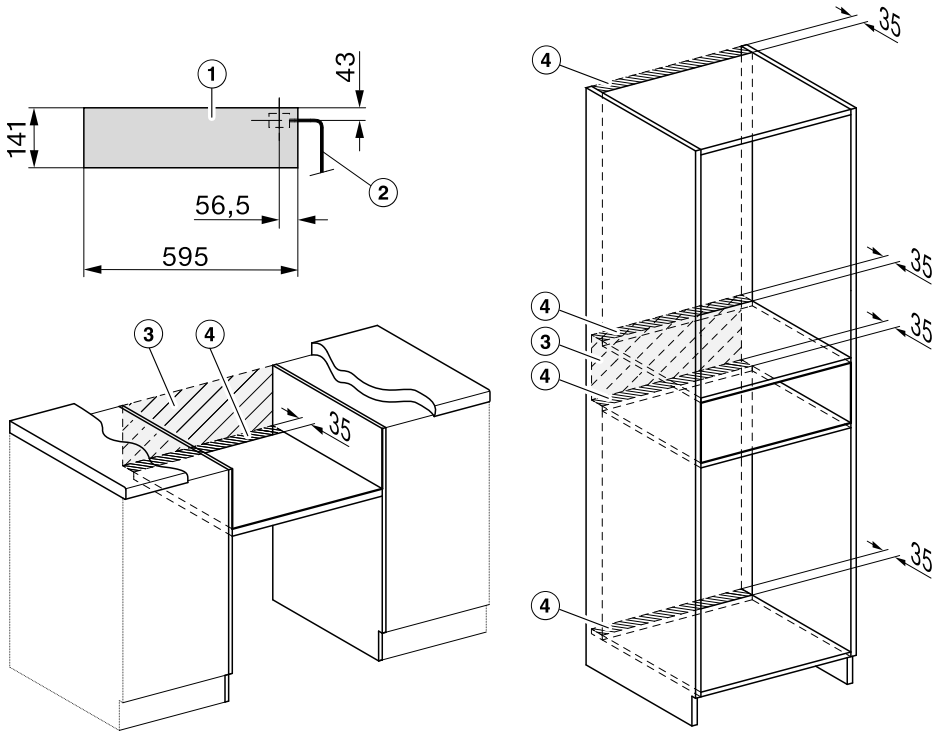

- ① View from the front
- ② Mains connection cable, L = 2200 mm
- ③ No connections permitted in this area
- ④ Ventilation cut-out, min. 1800 mm²

Installation

The drawer has an integrated vacuum pump which contains oil. To prevent oil from leaking out, the drawer must be transported and stored in a horizontal position only. Do not tilt the drawer and do not stand it up on its side.

Preparing the drawer

For safe transportation, the vacuum pump is provided with a transit device which must be removed before installation. The air filter supplied must be fitted in place of the transit device. There are also 2 safety screws on the back of the drawer to prevent the drawer from being opened unintentionally during transportation and when it is being removed from the packaging.

Fit the air filter **before** building in the drawer and remove the safety screws at the back. Otherwise the drawer cannot be operated and has to be taken out of the housing unit.

Keep the transit device and safety screws for any future transportation. The transit device can be secured to the back of the drawer.

Fitting the air filter and removing the safety screws

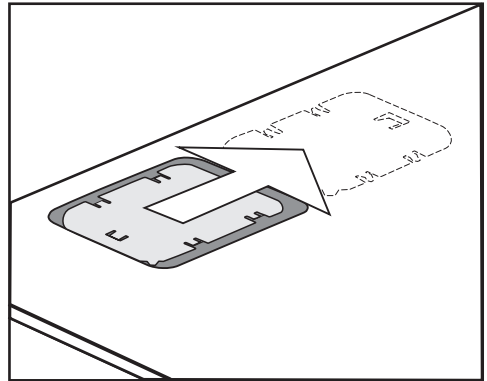

- Slide the cover to the right and remove it.

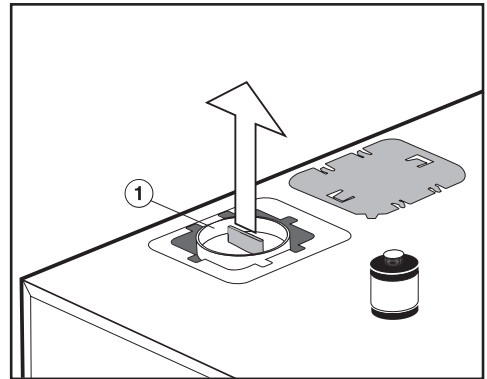

- Pull the red transit device ① up and out, e.g. with universal pliers.

Installation

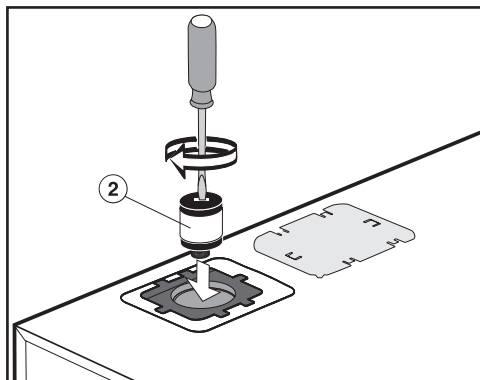

- Screw the air filter ② onto the vacuum pump using a screwdriver.

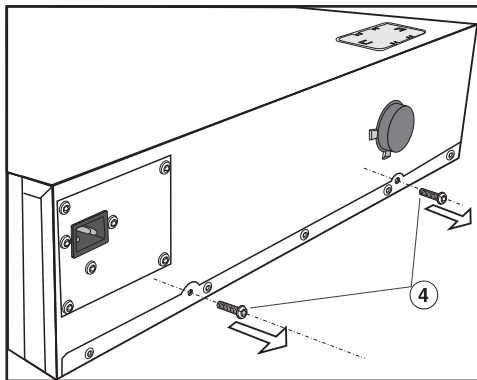

- Remove the safety screws ④ from the back of the drawer.

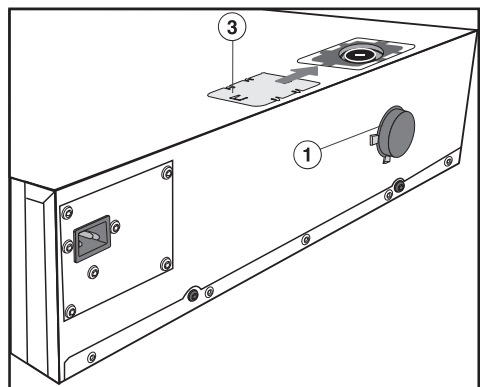

- Secure the transit device ① to the back of the drawer.
- Slide the cover ③ over the opening to close it.

Oil may leak while transporting the drawer.
Remove the air filter ② **before** transporting the drawer and plug the vacuum pump with the transit device ①.

To remove the air filter and fit the transit device, carry out these steps in reverse order.

Installing the drawer

 Danger of injury due to incorrect installation.

The drawer is heavy and will tip forwards when open.

Installation must be carried out by two people.

Keep the drawer closed until it has been fitted to the side walls of the housing unit using the supplied anti-tipping mechanism.

Check that the base on which the drawer will sit is clean and level (use a spirit level). This is important for the appliance to function correctly.

Fitting the anti-tipping mechanism

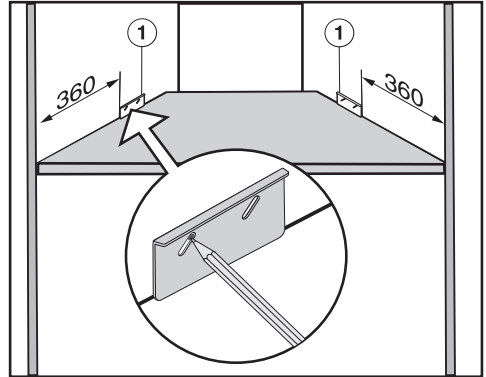

- Measure the distance to the right and left-hand side walls of the housing (see illustration).
- Mark the uppermost position in the long slot of the anti-tipping mechanism ①. Make sure that the anti-tipping mechanism is flush with the base of the housing unit.

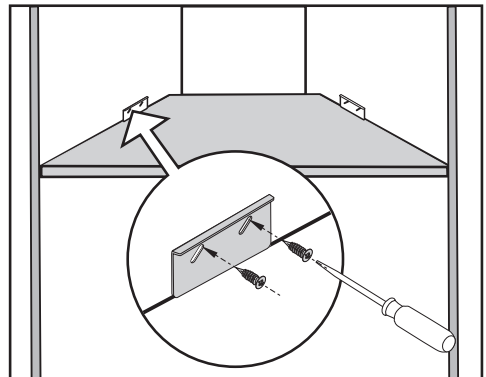

- Secure the anti-tipping mechanism to the right and left-hand side walls of the housing unit with the 4 screws supplied (4 x 16 mm).

Installation

Installing and connecting the drawer

- Check that the air filter is fitted and the safety screws have been removed from the back of the drawer (see “Installation – Building in”).
- Connect the mains cable to the drawer.
- Slide the closed drawer into the housing unit. When doing so make sure that the mains connection cable does not get trapped or damaged.
- Align the drawer at right angles.

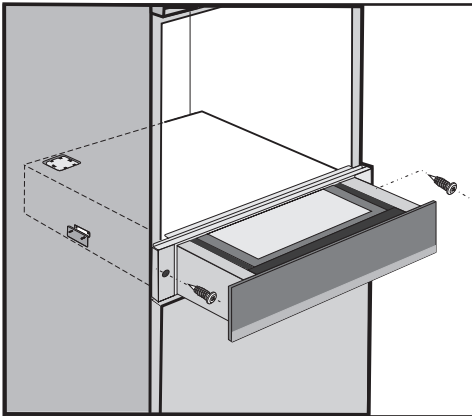

- Open the drawer and secure it to the right and left-hand side walls of the housing unit with the 2 wood screws supplied (3.5 x 25 mm).
- Remove the foam adhesive label from the glass lid.
- Remove the 4 foam adhesive labels from the back of the front panel on the right and left-hand sides.
- Connect the drawer to the mains.

When the drawer is first connected, or after an interruption to the mains, all of the sensor controls and indicators in the display will light up for approx. 10 seconds for testing (initialisation). As soon as they go out, the drawer is ready for use.

- When installing the combination appliance, protect the top edge of the front panel from abrasive marks.
- Install the combination appliance in accordance with the operating and installation instructions supplied with it.

Aligning the front of the drawer

After installing the combination appliance, it may be necessary under certain circumstances to align the front of the drawer and adjust the gap between the drawer and the combination appliance. To help you do this, there are 2 screws behind the drawer front with which the front is fixed to the drawer housing.

- Open the drawer.

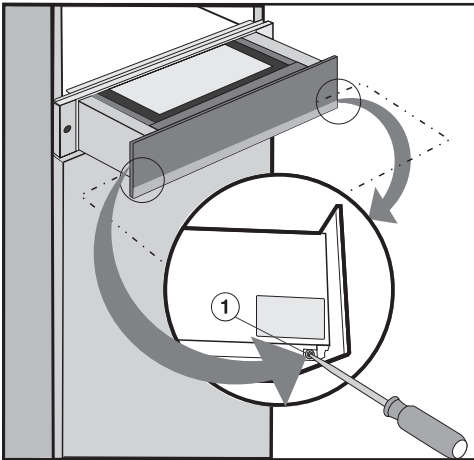

- Loosen the fixing screws ① on the right and left of the drawer housing. Do not remove the screws completely, as the front may fall off.
- Push the drawer up or down a little to correct the alignment and the gap.
- Tighten up the fixing screws.

Installation

Electrical connection

All electrical work should be carried out by a suitably qualified and competent person in strict accordance with current local and national safety regulations. Connection should be made via a switched socket. This will make it easier for service technicians should the appliance need to be repaired. The electrical socket must be easily accessible after installation.



Danger of injury.

Miele cannot be held liable for unauthorised installation, maintenance and repair work as this can be dangerous to users.

Miele cannot be held liable for damage or injury caused by incorrect installation, maintenance or repair work, or by an inadequate or faulty earthing system (e.g. electric shock).

If the plug is removed from the connection cable or if the cable is supplied without a plug, the appliance must be connected to the electrical supply by a suitably qualified electrician.

If the switched socket is not accessible after installation, or if the appliance is to be hard-wired, an additional means of disconnection must be provided for all poles. When switched off, there must be an all-pole contact gap of at least 3 mm in the switch (including switch, fuses and relays). Connection data is shown on the data plate. It must match the mains electrical supply.

After installation ensure that all electrical components are shielded and cannot be accessed by users.

Total power rating

See data plate

Connection data

The connection data is quoted on the data plate. Please ensure these match the household mains supply.

Residual current device

For extra safety, it is advisable to protect the drawer with a suitable residual current device (RCD) with a trip range of 30 mA.

Disconnecting from the mains



Risk of electric shock.

There is a risk of electric shock if the appliance is connected to the mains supply during repair or service work. After disconnection, ensure the appliance cannot be switched back on by mistake.

To disconnect the appliance from the mains power supply, do one of the following depending on installation:

Safety fuses

- Completely remove fuses.

Automatic circuit breakers

- Press the (red) test button until the middle (black) button springs out.

Built-in circuit breakers

- Circuit breakers at least type B or C:
Switch the lever from 1 (on) to 0 (off).

Residual current device (RCD)

- Switch the main switch from 1 (on) to 0 (off) or press the test button.

Replacing the mains connection cable

If the mains cable needs to be replaced it must be replaced with a special connection cable, type H 05 VV-F (PVC-insulated), available from your Miele dealer.

Miele Saudi Arabia

AWAD BADI NAHAS TRADING CO. LTD

Head Office:

Jeddah

P.O. Box 11529 Jeddah 21463

Tel. +966 12 2560888, Fax. +966 12 2560555

Hotline for customer care: 920003240

Website: www.awadnahas.com

Branches:

Jeddah

Madina Road

Tel. +966 12 6970060, Fax. +966 12 6970012

Jeddah

Sitteen Street

Tel. +966 12 6611675, Fax. +966 12 6606852

Jeddah

Miele Gallery

Al Thanyyan Group Building, Al-Madina Road,

Near, Al Rowdah District, Jeddah

Tel. +966 12 6989339 Ext. 100

Fax. +966 12 6989339 Ext. 200

Riyadh

Olaya Street

Tel. +966 11 2013501, Fax. +966 11 2013502

Taif

Hadiya Street

Tel. +966 12 7327001, Fax. +966 12 7369596

Khobar

Al Zahran Road

Tel. +966 13 8646150, Fax. +966 13 8646190

Miele United Arab Emirates

Miele Appliances Ltd.

Showroom 1

Eiffel 1 Building

Sheikh Zayed Road, Umm Al Sheif

P.O. Box 114782 - Dubai

United Arab Emirates

Tel. +971 4 3044 999

Fax. +971 4 3418 852

800-MIELE (64353)

E-Mail: info@miele.ae

Website: www.miele.ae

Webshop: shop.miele.ae

Manufacturer: Miele & Cie. KG, Carl-Miele-Straße 29, 33332 Gütersloh, Germany

EVS 7010, EVS 7110

en-AE, SA

M.-Nr. 11 260 570 / 01