

# CLOGGING INDICATOR

## Series OP (visual), OE (visual-electrical) block execution

Sheet No.  
**1628 K**

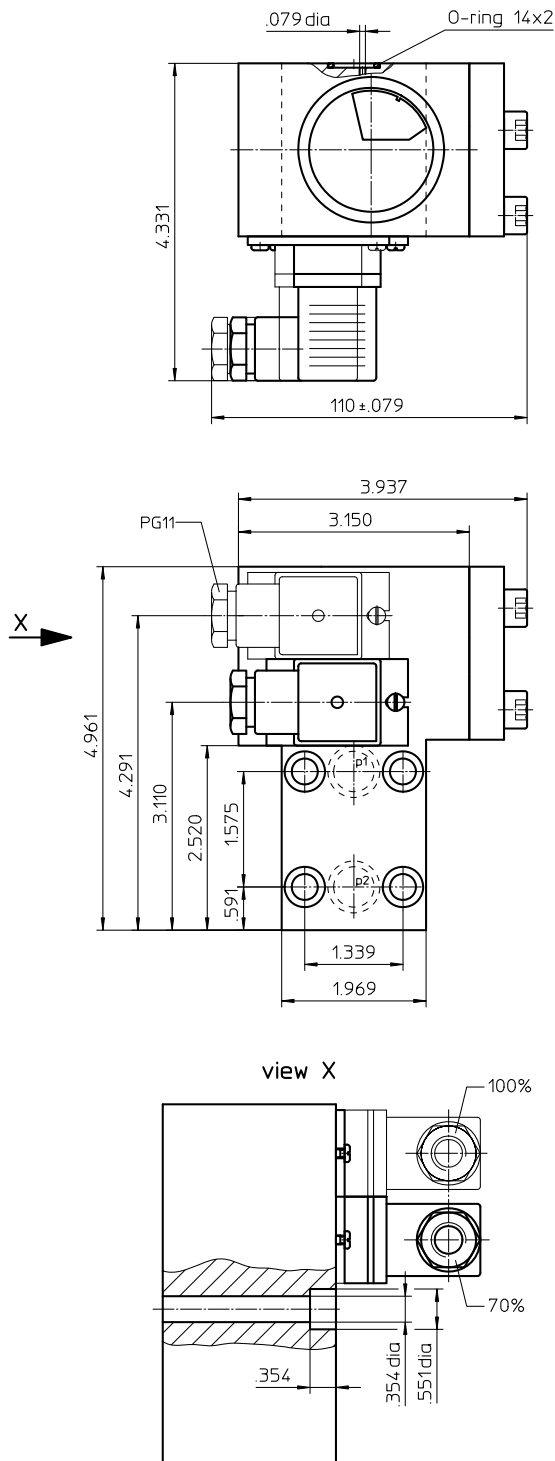

## 1. Clogging indicator OP-OE

### 1.1. Type index: (ordering example)

**OE1. 1.2. B. - . P. - 1**

1	2	3	4	5	6	7
---	---	---	---	---	---	---

#### 1 series:

- OE1 = clogging indicator, visual-electrical with 1 contact maker and contact breaker with 70% switching pressure difference
- OE2 = clogging indicator, visual-electrical with 1 contact maker and contact breaker with 70% and 100% switching pressure difference
- OE3 = clogging indicator, visual-electrical with 2 contacts maker and contacts breaker with 70% switching pressure difference
- OP = clogging indicator, visual (according to series OE without switching contacts)

#### 2 indicator-pressure difference: $\Delta p$ -nominal

0,3 = 4 PSI; 0,8 = 12 PSI; 1,2 = 17 PSI; 2,5 = 36 PSI; 4,5 = 65 PSI

#### 3 connection:

B = block execution with flange connection

#### 4 connection size:

- = standard

#### 5 sealing material:

P = Nitrile (NBR)

V = Viton (FPM)

#### 6 material: (housing)

- = standard (aluminium)

VA = stainless steel

#### 7 execution:

- = without switching contacts (OP)

1 = execution 1 (electrical limit facts see item 3)

2 = execution 2 (electrical limit facts see item 3)

## 2. Technical data:

permissible operating pressure: 914 PSI  
 permissible operating temperature:  
 - Nitrile (NBR) -13°F to +176°F  
 - Viton (FPM) +14°F to +176°F  
 permissible pressure difference:  $p_1 - p_2 \leq 232$  PSI  
 indicator-pressure difference: 4; 12; 17; 36; 65 PSI

## 3. Electrical limit facts:

execution 1: 175V DC, 0,5A, 10 VA  
 (CSA, UL licensed) 125V AC, 0,5A, 10 Watt  
 execution 2: 1...230V, 1A, 20 Watt  
 switch-over contact: contact maker and contact breaker  
 protection: IP 65

## 4. Symbols:

execution OE1

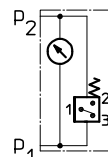

execution OE2, OE3

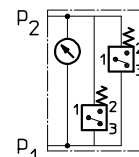

1+2 contact maker  
1+3 contact breaker

Dimensions: inches

Designs and performance values are subject to change.

EDV 05/19

## 5. Functioning:

The clogging indicator OE is a combined visual and electrical pressure difference indicator.

This type of pressure difference indicator can be mounted on all pressure filters with operating pressure  $\leq 914$  PSI, if the corresponding measuring ports on the filter housing are available.

With contamination of the filter element the difference between the supply pressure and the output pressure of the filter is increasing. Depending on this pressure difference but independent of the operating pressure, visual and electrical signals are released.

A pressure difference dependent measuring piston, charged with supply pressure and output pressure, moves towards a measuring spring.

Concerning the OE1 a permanent magnet which is integrated in the measuring piston switches - depending on the gauge length - a Reed-contact (magnetic-switch) and releases electrical control signals upon reaching a pressure difference of 70%.

The OE2 is equipped with two magnetic switches which release electrical control signals in a sequence of 70% and 100% of the switching pressure.

The OE3 is equipped with two magnetic switches triggering electrical control signals at 70% of the switching pressure (redundance of the switches).

The visual control signal is indicated by a blue-red scale which is connected to the magnetic measuring piston.

In the range of low pressure differences - depending on the gauge length of the measuring piston - the blue range of the scale appears first.

The indicated switching pressure difference is reached when the dividing line between the red and the blue range of the scale points to the marking on the display window.

## 6. Operating instruction:

**Note:** Consider data and connecting conditions mentioned in items 2 to 4.

## 7. Maintenance:

The device is maintenance-free. However, make sure that no solvents get in touch with the display window visual indicator nor with the piston-spring-system of the clogging indicator.