

Upflow/Horizontal, Downflow/ Horizontal, Gas-Fired, Direct Vent, Condensing, Single Stage Furnaces:

*UH1B040A9241A
*UH1B060A9361A
*UH1B080A9421A
*UH1C080A9601A

*UH1C100A9481A
*UH1D100A9601A
*UH1D120A9601A
*DH1B040A9241A

*DH1B065A9421A
*DH1C085A9481A
*DH1D110A9601A

*__First letter may be "A" or "T"

IMPORTANT — This document contains a wiring diagram and service information. This is customer property and is to remain with this unit. Please return to service information pack upon completion of work.

⚠ WARNING DISCONNECT POWER BEFORE SERVICING

PRODUCT SPECIFICATIONS ^①

MODEL	*UH1B040A9241A	*UH1B060A9361A	*UH1B080A9421A
TYPE	Upflow/Horizontal	Upflow/Horizontal	Upflow/Horizontal
RATINGS ^②			
Input BTUH ^③	40,000	60,000	80,000
Capacity BTUH (ICS) ^③	38,000	57,000	76,000
Temp. rise (Min.-Max.) °F.	30 - 60	30 - 60	35 - 65
BLOWER DRIVE			
	DIRECT	DIRECT	DIRECT
Diameter - Width (In.)	9 x 7	10 x 7	11 x 8
No. Used	1	1	1
Speeds (No.)	4	4	4
CFM vs. in. w.g.	See Fan Performance Table	See Fan Performance Table	See Fan Performance Table
Motor HP	1/5	1/3	1/2
R.P.M.	1075	1075	1075
Volts/Ph/Hz	115/1/60	115/1/60	115/1/60
COMBUSTION FAN - Type			
	Centrifugal	Centrifugal	Centrifugal
Drive - No. Speeds	Direct - 1	Direct - 1	Direct - 1
Motor HP - RPM	1/55 - 3000	1/15 - 3450	1/20 - 3450
Volts/Ph/Hz	115/1/60	115/1/60	115/1/60
FLA	1.0	1.75	0.71
FILTER — Furnished?			
Type Recommended	No	No	No
Hi Vel. (No.-Size-Thk.)	High Velocity 1 - 17x25 - 1in.	High Velocity 1 - 17x25 - 1in.	High Velocity 1 - 17x25 - 1in.
VENT PIPE DIAMETER — Min (In.) ^{⑤⑥}			
	2 Round	2 Round	3 Round
HEAT EXCHANGER			
Type	Aluminized Steel - Type I	Aluminized Steel - Type I	Aluminized Steel - Type I
- Unfired			
Gauge (Fired)	20	20	20
ORIFICES — Main			
Nat. Gas Qty. — Drill Size	2 — 45	3 — 45	4 — 45
L.P. Gas Qty. — Drill Size	2 — 56	3 — 56	4 — 56
GAS VALVE			
	Redundant - Single Stage	Redundant - Single Stage	Redundant - Single Stage
PILOT SAFETY DEVICE			
Type	Hot Surface Ignition	Hot Surface Ignition	Hot Surface Ignition
BURNERS — Type			
	Multiport Inshot	Multiport Inshot	Multiport Inshot
Number	2	3	4
POWER CONN. — V/Ph/Hz ^④			
	115/1/60	115/1/60	115/1/60
Ampacity (In Amps)	5.2	9.2	10.2
Max. Overcurrent Protection (Amps)	15	15	15
PIPE CONN. SIZE (IN.)			
	1/2	1/2	1/2
DIMENSIONS			
	H x W x D	H x W x D	H x W x D
Crated (In.)	41-3/4 x 19-1/2 x 30-1/2	41-3/4 x 19-1/2 x 30-1/2	41-3/4 x 19-1/2 x 30-1/2
WEIGHT			
Shipping (Lbs.)/Net (Lbs.)	139 / 129	150 / 140	158 / 148

Notes

- ① Central Furnace heating designs are certified to ANSI Z21.47 / CSA 2.3.
- ② For U.S. applications, above input ratings (BTUH) are up to 2,000 feet, derate 4% per 1,000 feet for elevations above 2,000 feet above sea level.
For Canadian applications, above input ratings (BTUH) are up to 4,500 feet, derate 4% per 1,000 feet for elevations above 4,500 feet above sea level.
- ③ Based on U.S. government standard tests.
- ④ The above wiring specifications are in accordance with National Electrical Code; however, installations must comply with local codes.
- ⑤ Refer to the Vent Length Table in the Installer's Guide or the Allowable Vent Length label located on the furnace.
- ⑥ All *UH1 and *DH1 furnace models have a vent outlet diameter that equals 2".

NOTICE: Since the manufacturer has a policy of continuous product and product data improvement, it reserves the right to change design and specifications without notice.

Service Facts

PRODUCT SPECIFICATIONS ^①

MODEL	*UH1C080A9601A	*UH1C100A9481A	*UH1D100A9601A	*UH1D120A9601A
TYPE	Upflow/Horizontal	Upflow/Horizontal	Upflow/Horizontal	Upflow/Horizontal
RATINGS ^②				
Input BTUH ^③	80,000	97,000	97,000	110,000
Capacity BTUH (ICS) ^③	76,000	92,150	92,150	104,500
Temp. rise (Min.-Max.) °F.	30 - 60	35 - 65	35 - 65	40 - 70
BLOWER DRIVE				
	DIRECT	DIRECT	DIRECT	DIRECT
Diameter - Width (In.)	11 x 10	10 x 10	11 x 10	11 x 10
No. Used	1	1	1	1
Speeds (No.)	4	4	4	4
CFM vs. in. w.g.	See Fan Performance Table	See Fan Performance Table	See Fan Performance Table	See Fan Performance Table
Motor HP	3/4	1/2	3/4	3/4
R.P.M.	1100	1075	1100	1100
Volts/Ph/Hz	115/1/60	115/1/60	115/1/60	115/1/60
COMBUSTION FAN - Type				
	Centrifugal	Centrifugal	Centrifugal	Centrifugal
Drive - No. Speeds	Direct - 1	Direct - 1	Direct - 1	Direct - 1
Motor HP - RPM	1/20 - 3450	1/20 - 3450	1/20 - 3450	1/20 - 3450
Volts/Ph/Hz	115/1/60	115/1/60	115/1/60	115/1/60
FLA	0.71	0.71	0.71	0.71
FILTER — Furnished?				
	No	No	No	No
Type Recommended	High Velocity	High Velocity	High Velocity	High Velocity
Hi Vel. (No.-Size-Thk.)	1 - 20x25 - 1in.	1 - 20x25 - 1in.	1 - 24x25 - 1in.	1 - 24x25 - 1in.
VENT PIPE DIAMETER —				
	3 Round	3 Round	3 Round	3 Round
Min (In.) ^{⑤⑥}				
HEAT EXCHANGER				
Type - Fired	Aluminized Steel - Type I	Aluminized Steel - Type I	Aluminized Steel - Type I	Aluminized Steel - Type I
- Unfired				
Gauge (Fired)	20	20	20	20
ORIFICES — Main				
Nat. Gas Qty. — Drill Size	4 — 45	5 — 45	5 — 45	6 — 45
L.P. Gas Qty. — Drill Size	4 — 56	5 — 56	5 — 56	6 — 56
GAS VALVE				
	Redundant - Single Stage	Redundant - Single Stage	Redundant - Single Stage	Redundant - Single Stage
PILOT SAFETY DEVICE				
Type	Hot Surface Ignition	Hot Surface Ignition	Hot Surface Ignition	Hot Surface Ignition
BURNERS — Type				
	Multiport Inshot	Multiport Inshot	Multiport Inshot	Multiport Inshot
Number	4	5	5	6
POWER CONN. — V/Ph/Hz ^④				
	115/1/60	115/1/60	115/1/60	115/1/60
Ampacity (In Amps)	13.5	12.5	12.9	12.9
Max. Overcurrent Protection (Amps)	20	20	20	20
PIPE CONN. SIZE (IN.)				
	1/2	1/2	1/2	1/2
DIMENSIONS				
	H x W x D	H x W x D	H x W x D	H x W x D
Crated (In.)	41-3/4 x 23 x 30-1/2	41-3/4 x 23 x 30-1/2	41-3/4 x 26-1/2 x 30-1/2	41-3/4 x 26-1/2 x 30-1/2
WEIGHT				
Shipping (Lbs.)/Net (Lbs.)	171 / 160	171 / 160	197 / 185	205 / 193

Notes

- ① Central Furnace heating designs are certified to ANSI Z21.47 / CSA 2.3.
- ② For U.S. applications, above input ratings (BTUH) are up to 2,000 feet, derate 4% per 1,000 feet for elevations above 2,000 feet above sea level.
For Canadian applications, above input ratings (BTUH) are up to 4,500 feet, derate 4% per 1,000 feet for elevations above 4,500 feet above sea level.
- ③ Based on U.S. government standard tests.
- ④ The above wiring specifications are in accordance with National Electrical Code; however, installations must comply with local codes.
- ⑤ Refer to the Vent Length Table in the Installer's Guide or the Allowable Vent Length label located on the furnace.
- ⑥ All *UH1 and *DH1 furnace models have a vent outlet diameter that equals 2".

PRODUCT SPECIFICATIONS ^①

MODEL	*DH1B040A9241A	*DH1B065A9421A	*DH1C085A9481A	*DH1D110A9601A
TYPE	Downflow/Horizontal	Downflow/Horizontal	Downflow/Horizontal	Downflow/Horizontal
RATINGS ^②				
Input BTUH ^③	40,000	60,000	80,000	110,000
Capacity BTUH (ICS) ^③	38,000	57,000	76,000	104,500
Temp. rise (Min.-Max.) °F.	30 - 60	25 - 55	30 - 60	35 - 65
BLOWER DRIVE	DIRECT	DIRECT	DIRECT	DIRECT
Diameter - Width (In.)	10 x 7	11 x 8	11 x 10	11 x 10
No. Used	1	1	1	1
Speeds (No.)	4	4	4	4
CFM vs. in. w.g.	See Fan Performance Table	See Fan Performance Table	See Fan Performance Table	See Fan Performance Table
Motor HP	1/5	1/2	1/2	3/4
R.P.M.	1080	1075	1075	1100
Volts/Ph/Hz	115/1/60	115/1/60	115/1/60	115/1/60
COMBUSTION FAN - Type	Centrifugal	Centrifugal	Centrifugal	Centrifugal
Drive - No. Speeds	Direct - 1	Direct - 1	Direct - 1	Direct - 1
Motor HP - RPM	1/55 - 3000	1/25 - 3200	1/20 - 3450	1/20 - 3450
Volts/Ph/Hz	115/1/60	115/1/60	115/1/60	115/1/60
FLA	1.14	1.35	0.71	0.71
FILTER — Furnished?	No	No	No	No
Type Recommended	High Velocity	High Velocity	High Velocity	High Velocity
Hi Vel. (No.-Size-Thk.)	2 - 14x20 - 1in.	2 - 14x20 - 1in.	2 - 16x20 - 1in.	2 - 16x20 - 1in.
VENT PIPE DIAMETER — Min (In.) ^{⑤⑥}	2 Round	2 Round	2.5 Round	2.5 Round
HEAT EXCHANGER				
Type - Fired	Aluminized Steel - Type I	Aluminized Steel - Type I	Aluminized Steel - Type I	Aluminized Steel - Type I
- Unfired				
Gauge (Fired)	20	20	20	20
ORIFICES — Main				
Nat. Gas Qty. — Drill Size	2 — 45	4 — 48	5 — 48	6 — 48
L.P. Gas Qty. — Drill Size	2 — 56	4 — 56	5 — 56	6 — 56
GAS VALVE	Redundant - Single Stage	Redundant - Single Stage	Redundant - Single Stage	Redundant - Single Stage
PILOT SAFETY DEVICE				
Type	Hot Surface Ignition	Hot Surface Ignition	Hot Surface Ignition	Hot Surface Ignition
BURNERS — Type	Multiport Inshot	Multiport Inshot	Multiport Inshot	Multiport Inshot
Number	2	4	5	6
POWER CONN. — V/Ph/Hz ^④	115/1/60	115/1/60	115/1/60	115/1/60
Ampacity (In Amps)	4.8	11.4	12.5	12.9
Max. Overcurrent Protection (Amps)	15	15	20	20
PIPE CONN. SIZE (IN.)	1/2	1/2	1/2	1/2
DIMENSIONS	H x W x D	H x W x D	H x W x D	H x W x D
Crated (In.)	41-3/4 x 19-1/2 x 30-1/2	41-3/4 x 19-1/2 x 30-1/2	41-3/4 x 23 x 30-1/2	41-3/4 x 26-1/2 x 30-1/2
WEIGHT				
Shipping (Lbs.)/Net (Lbs.)	145 / 135	158 / 148	171 / 160	205 / 193

Notes

- ① Central Furnace heating designs are certified to ANSI Z21.47 / CSA 2.3.
- ② For U.S. applications, above input ratings (BTUH) are up to 2,000 feet, derate 4% per 1,000 feet for elevations above 2,000 feet above sea level.
For Canadian applications, above input ratings (BTUH) are up to 4,500 feet, derate 4% per 1,000 feet for elevations above 4,500 feet above sea level.
- ③ Based on U.S. government standard tests.
- ④ The above wiring specifications are in accordance with National Electrical Code; however, installations must comply with local codes.
- ⑤ Refer to the Vent Length Table in the Installer's Guide or the Allowable Vent Length label located on the furnace.
- ⑥ All *UH1 and *DH1 furnace models have a vent outlet diameter that equals 2".

WARNING

CARBON MONOXIDE POISONING HAZARD

Failure to follow the steps outlined below for each appliance connected to the venting system being placed into operation could result in carbon monoxide poisoning or death.

The following steps shall be followed for each appliance connected to the venting system being placed into operation, while all other appliances connected to the venting system are not in operation:

1. Seal any unused openings in the venting system.
2. Inspect the venting system for proper size and horizontal pitch, as required in the National Fuel Gas Code, ANSI Z223.1/NFPA 54 or the CAN/CGA B149 Installation Codes and these instructions. Determine that there is no blockage or restriction, leakage, corrosion and other deficiencies which could cause an unsafe condition.
3. As far as practical, close all building doors and windows and all doors between the space in which the appliance(s) connected to the venting system are located and other deficiencies which could cause an unsafe condition.
4. Close fireplace dampers.
5. Turn on clothes dryers and any appliance not connected to the venting system. Turn on any exhaust fans, such as range hoods and bathroom exhausts, so they are operating at maximum speed. Do not operate a summer exhaust fan.
6. Follow the lighting instructions. Place the appliance being inspected into operation. Adjust the thermostat so appliance is operating continuously.
7. If improper venting is observed during any of the above tests, the venting system must be corrected in accordance with the National Fuel Gas Code, ANSI Z221.1/NFPA 54 and/or CAN/CGA B149 Installation Codes.
8. After it has been determined that each appliance connected to the venting system properly vents where tested as outlined above, return doors, windows, exhaust fans, fireplace dampers and any other gas-fired burning appliance to their previous conditions of use.

WARNING

FIRE OR EXPLOSION HAZARD

Failure to follow the safety warnings exactly could result in serious injury, death or property damage. Never test for gas leaks with an open flame. Use a commercially available soap solution made specifically for the detection of leaks to check all connections. A fire or explosion may result causing property damage, personal injury, or loss of life.

WARNING

FIRE OR EXPLOSION HAZARD

Failure to follow the safety warnings exactly could result in serious injury, death or property damage. Improper servicing could result in dangerous operation, serious injury, death, or property damage.

CAUTION

The integrated furnace control is polarity sensitive. The hot leg of the 115 VAC power must be connected to the BLACK field lead.

SEQUENCE OF OPERATION

Thermostat call for heat

R and W thermostat contacts close signaling the control module to run its self-check routine. After the control module has verified that the pressure switch contacts are open and the limit switch(es) contacts are closed, the draft blower will be energized.

As the induced draft blower comes up to speed, the pressure switch contacts will close and the ignitor warm up period will begin. The ignitor will heat for approximately 20 seconds, then the gas valve is energized to permit gas flow to the burners. The flame sensor confirms that ignition has been achieved.

After the flame sensor confirms within a 4 second trial period that ignition has been achieved, the delay to fan ON period begins timing. After approximately 45 seconds the indoor blower motor will be energized and continue to run during the heating cycle. Downflow models have a 10 second blower ON delay.

When the thermostat is satisfied, R and W thermostat contacts open, the gas valve will close, the flames will extinguish, and the induced draft blower will be de-energized. The indoor blower motor will continue to run for the fan off period (Field selectable at 60, 100, 140 or 180 seconds), then be de-energized by the control module.

AIRFLOW ADJUSTMENT

Check inlet and outlet air temperatures to make sure they are within the ranges specified on the furnace rating nameplate. If the airflow needs to be increased or decreased, see the wiring diagram for information on changing the speed of the blower motor.

⚠ WARNING

Disconnect power to the unit before removing the blower door.

Failure to follow this warning could result in personal injury from moving parts.

This unit is equipped with a blower door switch which cuts power to the blower and gas valve causing shutdown when the door is removed. Operation with the door removed or ajar can permit the escape of dangerous fumes. All panels must be securely closed at all times for safe operation of the furnace.

⚠ WARNING

BODILY INJURY CAN RESULT FROM HIGH VOLTAGE ELECTRICAL COMPONENTS, FAST MOVING FANS, AND COMBUSTIBLE GAS. FOR PROTECTION FROM THESE INHERENT HAZARDS DURING INSTALLATION AND SERVICING, THE ELECTRICAL SUPPLY MUST BE DISCONNECTED AND THE MAIN GAS VALVE MUST BE TURNED OFF. IF OPERATING CHECKS MUST BE PERFORMED WITH THE UNIT OPERATING, IT IS THE TECHNICIANS RESPONSIBILITY TO RECOGNIZE THESE HAZARDS AND PROCEED SAFELY.

INDOOR BLOWER TIMING

Heating: The control module controls the indoor blower. The blower start is fixed at 45 seconds after ignition. Downflow models have a 10 second blower ON delay. The FAN-OFF period is field selectable by dip switches at 60, 100, 140, or 180 seconds. The factory setting is 100 seconds (See wiring diagram).

Cooling: The fan delay off period is factory set at 0 seconds. The option for 80 second delay off is field selectable (See wiring diagram).

NOTE:

Direct drive motors have bearings which are permanently lubricated and under normal use, lubrication is not recommended.

The following warning complies with State of California law, Proposition 65.

⚠ WARNING

This product contains fiberglass wool insulation!

Fiberglass dust and ceramic fibers are believed by the State of California to cause cancer through inhalation. Glasswool fibers may also cause respiratory, skin, or eye irritation.

PRECAUTIONARY MEASURES

- Avoid breathing fiberglass dust.
- Use a NIOSH approved dust/mist respirator.
- Avoid contact with the skin or eyes. Wear long-sleeved, loose-fitting clothing, gloves, and eye protection.
- Wash clothes separately from other clothing: rinse washer thoroughly.
- Operations such as sawing, blowing, tear-out, and spraying may generate fiber concentrations requiring additional respiratory protection. Use the appropriate NIOSH approved respirator in these situations.

FIRST AID MEASURES

Eye Contact – Flush eyes with water to remove dust. If symptoms persist, seek medical attention.

Skin Contact – Wash affected areas gently with soap and warm water after handling.

The following warning complies with State of California law, Proposition 65.

⚠ WARNING

Hazardous Gases!

Exposure to fuel substances or by-products of incomplete fuel combustion is believed by the state of California to cause cancer, birth defects, or other reproductive harm.

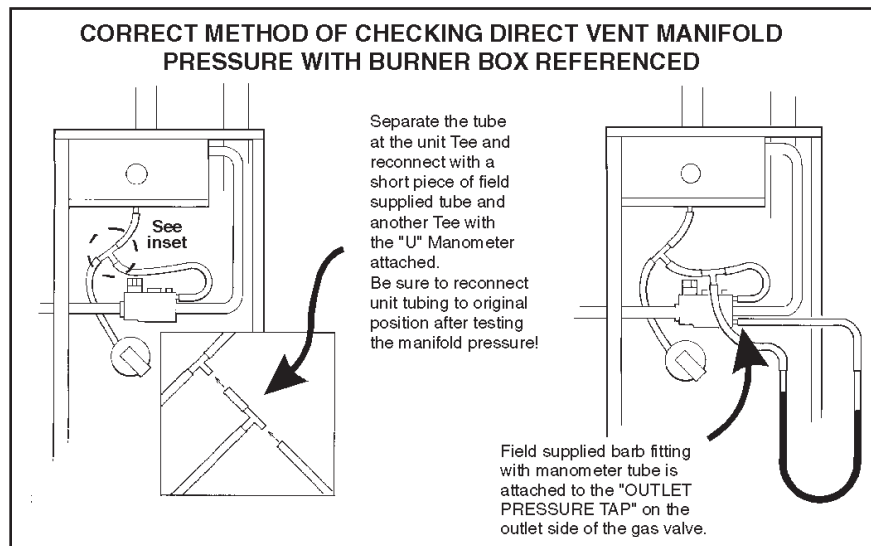

Service Facts

WIRING DIAGRAM

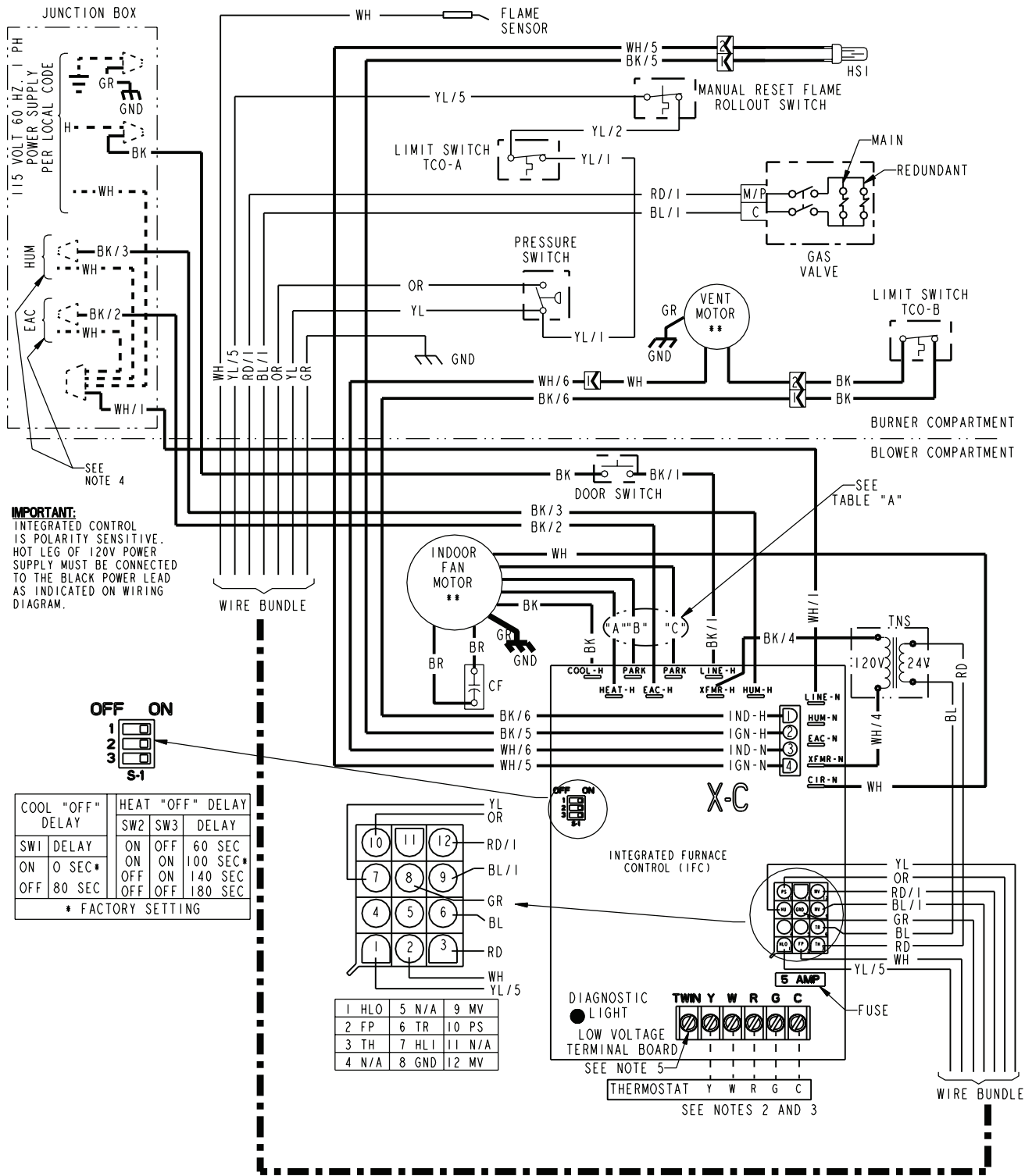

From Dwg. D343498P01 Rev. 2

(continued on next page)

SCHEMATIC DIAGRAM

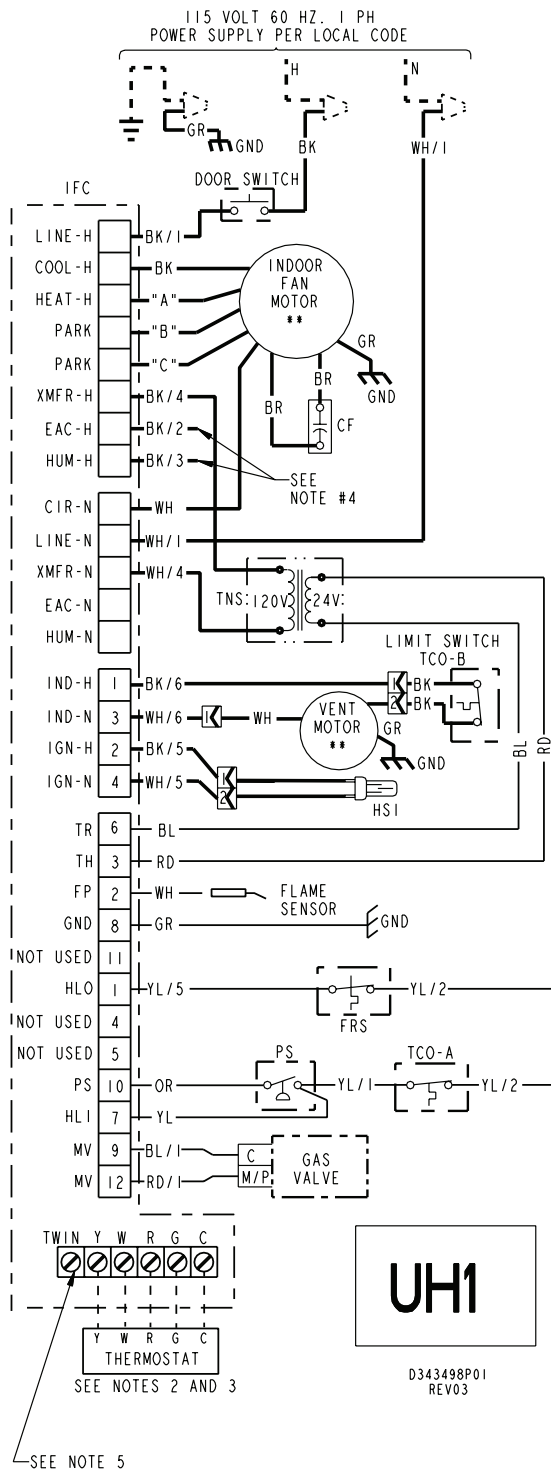

MODEL	HEAT "A"	PARK "B"	PARK "C"
*UH1B040A9241A#	YL	RD	BL
*UH1B060A9361A#	BL	RD	YL
*UH1B080A9421A#	BL	RD	YL
*UH1C080A9601A#	YL	RD	BL
*UH1C100A9481A#	BL	RD	YL
*UH1D100A9601A#	YL	RD	BL
*UH1D120A9601A#	BL	RD	YL

* PREFIX MAY BE "A" OR "T"
SUFFIX MAY BE "A" THROUGH "Z"

RD = LOW BL = MED. HIGH
YL = MED. LOW BK = HIGH

WARNING
HAZARDOUS VOLTAGE:
DISCONNECT ALL ELECTRICAL POWER INCLUDING REMOTE DISCONNECTS BEFORE SERVICING.
FAILURE TO DISCONNECT POWER BEFORE SERVICING CAN CAUSE SEVERE PERSONAL INJURY OR DEATH.

CAUTION
USE COPPER CONDUCTORS ONLY!
UNIT TERMINALS ARE NOT DESIGNED TO ACCEPT OTHER TYPES OF CONDUCTORS.
FAILURE TO DO SO MAY CAUSE DAMAGE TO THE EQUIPMENT.

INTEGRATED FURNACE CONTROL
REPLACE WITH PART CNT03076 OR EQUIVALENT
INPUT: 25 VAC, 60 HZ.
XFMR SEC. CURRENT: 450 MA.
MV OUTPUT: 1.5 A @ 24 VAC
IND OUTPUT: 2.2 FLA, 3.5 LRA @ 120 VAC
CIRC. BLOWER OUTPUT: 14.5 FLA, 26 LRA @ 120 VAC
HUMIDIFIER & AIR CLEANER
MAX. LOAD: 1.0 A @ 120 VAC
IGNITER OUTPUT: 2.0 A @ 120 VAC

DIAGNOSTIC CODES

FLASHING SLOW: NORMAL - NO CALL FOR HEAT
FLASHING FAST: NORMAL - CALL FOR HEAT
CONTINUOUS ON: REPLACE IFC
CONTINUOUS OFF: CHECK POWER

5 FLASHES: FLAME SENSED WHEN NO FLAME SHOULD BE PRESENT
6 FLASHES: 115 VAC POWER REVERSED POLARITY OR POOR GROUNDING
7 FLASHES: GAS VALVE CIRCUIT ERROR
8 FLASHES: LOW FLAME SENSE SIGNAL
9 FLASHES: CHECK IGNITER

2 FLASHES: EXTERNAL LOCKOUT (RETRIES OR RECYCLES EXCEEDED)
3 FLASHES: PRESSURE SWITCH ERROR
4 FLASHES: OPEN LIMIT DEVICE

TCO THERMAL CUT OUT	PS PRESSURE SWITCH	FRS FLAME ROLLOUT SWITCH	FP FLAME SENSOR	CHASSIS GROUND	HSI HOT SURFACE IGNITER	DOOR SWITCH	TCF CAPACITOR	COIL
— LINE 24 v WIRING	- - - LINE FIELD WIRING	- - - - 24 v WIRING	■ ■ INTERNAL THERMAL PROTECTION					

BK BLACK	GR GREEN
WH WHITE	BR BROWN
YL YELLOW	RD RED
OR ORANGE	BL BLUE

WIRE COLOR
BK/1 NUMBER ID (IF ANY)

L LINE	TH 24 VAC (HOT)
N NEUTRAL	TR 24 VAC (COMMON)
GND GROUND	MV MAIN GAS VALVE
B/C COMMON	TNS TRANSFORMER
HLO HIGH LIMIT OUTPUT	
HLI HIGH LIMIT INPUT	

- NOTES:**
- IF ANY OF THE ORIGINAL WIRING AS SUPPLIED WITH THIS FURNACE MUST BE REPLACED, IT MUST BE WITH WIRE HAVING A TEMPERATURE RATING OF AT LEAST 105 C.
 - THERMOSTAT HEAT ANTICIPATOR SETTING: .38 AMPS
 - FOR PROPER OPERATION OF COOLING SPEED, "Y" TERMINAL MUST BE CONNECTED TO THE ROOM THERMOSTAT
 - THESE LEADS PROVIDE 120V POWER CONNECTIONS FOR ELECTRONIC AIR CLEANER (EAC) AND HUMIDIFIER (HUM). MAX. LOAD: 1.0 AMPS EACH.
 - WHEN TWINNING TWO FURNACES, BOTH UNITS MUST BE CONNECTED TO THE SAME 115 VAC PHASE CONNECT THE TWO UNITS 'TWIN' TERMINALS WITH 14 TO 22 AWG. WIRE.

From Dwg. D343498 Rev. 2

SCHEMATIC DIAGRAM

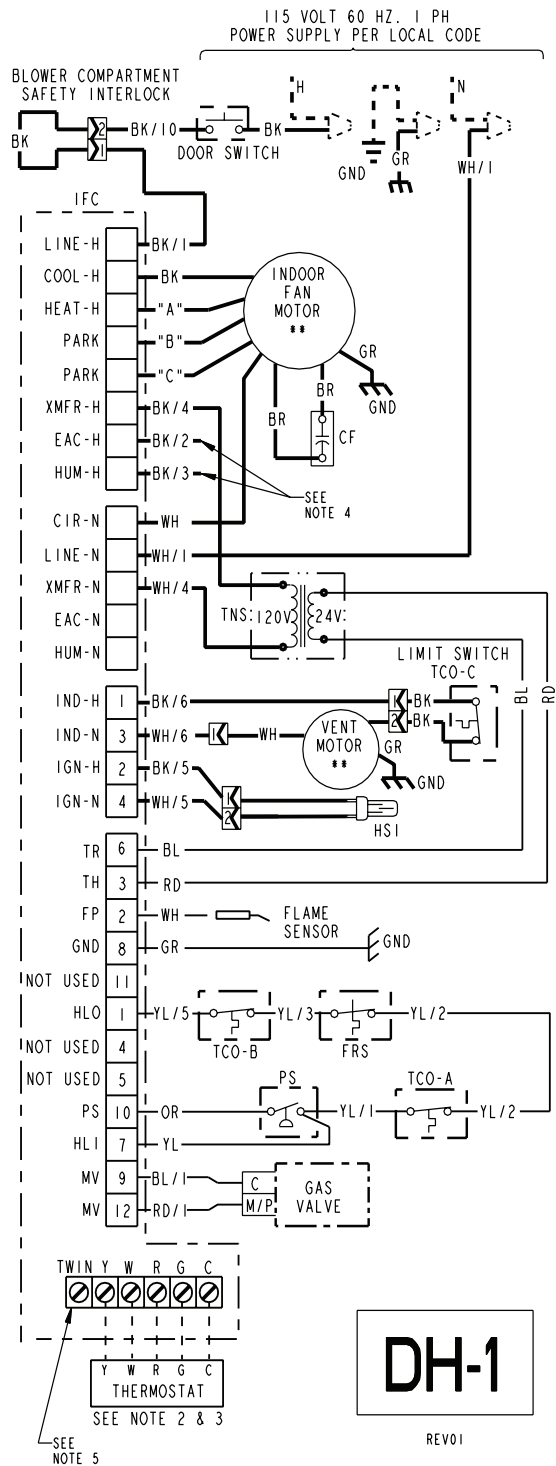

TABLE "A"			
SPEED TAPS FOR I. D. FAN MOTOR			
MODEL	HEAT "A"	PARK "B"	PARK "C"
*DHIB040A9241A#	YL	RD	BL
*DHIB065A9421A#	BL	RD	YL
*DHIC085A9481A#	BL	RD	YL
*DHIDI10A9601A#	BL	RD	YL

RD = LOW BL = MED. HIGH
YL = MED. LOW BK = HIGH

* - MAY BE PREFIX "A" OR "T"
- MAY BE SUFFIX "A" THROUGH "Z"

WARNING

HAZARDOUS VOLTAGE:
DISCONNECT ALL ELECTRICAL POWER INCLUDING REMOTE DISCONNECTS BEFORE SERVICING.
FAILURE TO DISCONNECT POWER BEFORE SERVICING CAN CAUSE SEVERE PERSONAL INJURY OR DEATH.

CAUTION

USE COPPER CONDUCTORS ONLY!
UNIT TERMINALS ARE NOT DESIGNED TO ACCEPT OTHER TYPES OF CONDUCTORS.
FAILURE TO DO SO MAY CAUSE DAMAGE TO THE EQUIPMENT.

INTEGRATED FURNACE CONTROL
REPLACE WITH PART CNT05995 OR EQUIVALENT
INPUT: 25 VAC, 60 HZ.
XFMR SEC. CURRENT: 450 MA.
MV OUTPUT: 1.5 A @ 24 VAC
IND OUTPUT: 2.2 FLA, 3.5 LRA @ 120 VAC
CIRC. BLOWER OUTPUT: 14.5 FLA, 26.0 LRA @ 120 VAC
HUMIDIFIER & AIR CLEANER
MAX. LOAD: 1.0 A @ 120 VAC
IGNITER OUTPUT: 6.0 A @ 120 VAC

DIAGNOSTIC CODES

- | | |
|--|---|
| FLASHING SLOW: NORMAL - NO CALL FOR HEAT | 5 FLASHES: FLAME SENSED WHEN NO FLAME SHOULD BE PRESENT |
| FLASHING FAST: NORMAL - CALL FOR HEAT | 6 FLASHES: 115 VAC POWER REVERSED |
| CONTINUOUS ON: REPLACE IFC | CONTINUOUS OFF: CHECK POWER |
| 2 FLASHES: EXTERNAL LOCKOUT (RETRIES OR RECYCLES EXCEEDED) | 7 FLASHES: GAS VALVE CIRCUIT ERROR |
| 3 FLASHES: PRESSURE SWITCH ERROR | 8 FLASHES: LOW FLAME SENSE SIGNAL |
| 4 FLASHES: OPEN LIMIT DEVICE | 9 FLASHES: CHECK IGNITER |

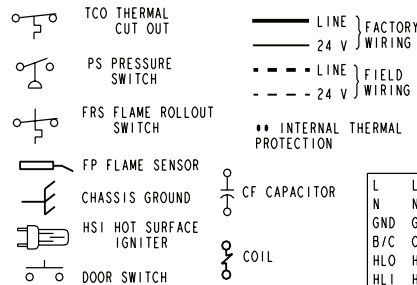

BK	BLACK	GR	GREEN
WH	WHITE	BR	BROWN
YL	YELLOW	RD	RED
OR	ORANGE	BL	BLUE

WIRE COLOR
BK/1 NUMBER ID (IF ANY)

L	LINE	TR	24 VAC (HOT)
N	NEUTRAL	TH	24 VAC (COMMON)
GND	GROUND	MV	MAIN GAS VALVE
B/C	COMMON	TNS	TRANSFORMER
HLO	HIGH LIMIT OUTPUT		
HLI	HIGH LIMIT INPUT		

NOTES:

- IF ANY OF THE ORIGINAL WIRING AS SUPPLIED WITH THIS FURNACE MUST BE REPLACED, IT MUST BE WITH WIRE HAVING A TEMPERATURE RATING OF AT LEAST 105 C.
- THERMOSTAT HEAT ANTICIPATOR SETTING: .38 AMPS
- FOR PROPER OPERATION OF COOLING SPEED, "Y" TERMINAL MUST BE CONNECTED TO THE ROOM THERMOSTAT.
- THESE LEADS PROVIDE 120V POWER CONNECTIONS FOR ELECTRONIC AIR CLEANER (EAC) AND HUMIDIFIER (HUM). MAX. LOAD: 1.0 AMPS EACH.
- WHEN TWINNING TWO FURNACES, BOTH UNITS MUST BE CONNECTED TO THE SAME 115 VAC PHASE. CONNECT THE TWO UNITS 'TWIN' TERMINALS WITH 14 TO 22 AWG. WIRE.

Service Facts

PERIODIC SERVICING REQUIREMENTS

WARNING

Disconnect power to the unit before removing the blower door.

Failure to follow this warning could result in personal injury from moving parts.

1. GENERAL INSPECTION – *Examine the furnace installation annually for the following items:*
 - a. All flue product carrying areas external to the furnace (i.e. chimney, vent connector) are clear and free of obstruction. A vent screen in the end of the vent (flue) pipe must be inspected for blockage annually.
 - b. The vent connector is in place, slopes upward and is physically sound without holes or excessive corrosion.
 - c. The return air duct connection(s) is physically sound, is sealed to the furnace and terminates outside the space containing the furnace.
 - d. The physical support of the furnace should be sound without sagging, cracks, gaps, etc., around the base so as to provide a seal between the support and the base.
 - e. There are no obvious signs of deterioration of the furnace.
2. FILTERS – Filters should be cleaned or replaced (with high velocity filters only), monthly and more frequently during high use times of the year such as midsummer or midwinter.
3. BLOWERS – The blower size and speed determine the air volume delivered by the furnace. The blower motor bearings are factory lubricated and under normal operating conditions do not require servicing. If motor lubrication is required it should only be done by a qualified servicer. Annual cleaning of the blower wheel and housing is recommended for maximum air output, and this must be performed only by a qualified servicer or service agency.

WARNING

Do NOT touch igniter. It is extremely hot.
Failure to follow this warning could result in severe burns.

4. IGNITER – This unit has a special hot surface direct ignition device that automatically lights the burners. Please note that it is very fragile and should be handled with care.

WARNING

CARBON MONOXIDE POISONING HAZARD
Failure to follow the service and/or periodic maintenance instructions for the furnace and venting system, could result in carbon monoxide poisoning or death.

5. BURNERS – Gas burners do not normally require scheduled servicing, however, accumulation of foreign material may cause a yellowing flame or delayed ignition. Either condition indicates that a service call is required. For best operation, burners should be cleaned annually by a qualified servicer.

Turn off gas and electric power supply. To clean burners, remove burner box cover (6 to 8 screws) and the top burner bracket. Lift burners from orifices.

NOTE:

Be careful NOT to break igniter when removing burners. Clean burners with brush and/or vacuum cleaner. Reassemble parts by reversal of the above procedure.

WARNING

CARBON MONOXIDE POISONING HAZARD

Failure to follow the service and/or periodic maintenance instructions for the furnace and venting system, could result in carbon monoxide poisoning or death.

NOTE:

On LP (propane) units, some light yellow tipping of the outer mantle is normal. Inner mantle should be bright blue.

Natural gas units should not have any yellow tipped flames. This condition indicates that a service call is required. For best operation, burners should be cleaned annually by a qualified servicer.

NOTE:

On LP (propane) units, due to variations in BTU content and altitude, servicing may be required at shorter intervals.

6. HEAT EXCHANGER/FLUE PIPE – *These items must be inspected for signs of corrosion, and/or deterioration at the beginning of each heating season by a qualified service technician and cleaned annually for best operation. To clean flue gas passages, follow recommendations below:*
 - a. Turn off gas and electric power supply.
 - b. Inspect flue pipe exterior for cracks, leaks, holes or leaky joints. Some discoloration of PVC pipe is normal.
 - c. Remove burner compartment door from furnace.
 - d. Inspect around insulation covering flue collector box. Inspect induced draft blower connections from recuperative cell and to the flue pipe connection.
 - e. Remove burners. (See 5.)
 - f. Use a mirror and flashlight to inspect interior of heat exchanger, be careful not to damage the igniter, flame sensor or other components.
 - g. If any corrosion is present, contact a service agency. Heat exchanger should be cleaned by a qualified service technician.
 - h. After inspection is complete replace burners, and all furnace doors.
 - i. Restore gas supply. Check for leaks using a soap solution. Restore electrical supply. Check unit for normal operation.
7. FURNACE CONDENSATE DRAIN TUBES – Condensate drain tubes must be checked periodically to assure that condensate can flow freely from unit to drain. If a drain problem cannot be corrected, call a qualified servicer.
8. COOLING COIL CONDENSATE DRAIN – If a cooling coil is installed with the furnace, condensate drains should be checked and cleaned periodically to assure that condensate can drain freely from coil to drain. If condensate cannot drain freely water damage could occur. (See Condensate Drain in Installer's Guide.)

CAUTION

Label all wires prior to disconnection when servicing controls. Wiring errors can cause improper and dangerous operation.
Verify proper operation after servicing.

Service Facts

FURNACE AIRFLOW (CFM) VS. EXTERNAL STATIC PRESSURE (in. w.c.)										
MODEL	SPEED TAP	0.10	0.20	0.30	0.40	0.50	0.60	0.70	0.80	0.90
*UH1B040A9241A	4 - HIGH - Black	1043	992	930	885	812	740	647	518	457
	3 - MED.-HIGH - Blue	940	895	841	791	726	650	559	420	390
	2 - MED.-LOW - Yellow	837	798	752	705	649	560	438	305	279
	1 - LOW - Red	729	694	657	600	545	478	376	220	178
*UH1B060A9361A	4 - HIGH - Black	1359	1313	1264	1204	1144	1079	1004	919	812
	3 - MED.-HIGH - Blue	1232	1199	1161	1116	1065	1004	934	852	744
	2 - MED.-LOW - Yellow	1077	1054	1027	994	953	904	845	768	666
	1 - LOW - Red	926	913	895	871	836	792	733	670	570
*UH1B080A9421A	4 - HIGH - Black	1646	1611	1573	1530	1477	1421	1360	1289	1200
	3 - MED.-HIGH - Blue	1366	1356	1337	1311	1280	1243	1197	1139	1060
	2 - MED.-LOW - Yellow	1175	1159	1145	1130	1108	1081	1045	993	929
	1 - LOW - Red	1004	994	997	982	963	943	907	866	824
*UH1C080A9601A	4 - HIGH - Black	2235	2194	2152	2105	2057	1987	1916	1836	1757
	3 - MED.-HIGH - Blue	1921	1904	1888	1861	1835	1797	1760	1698	1636
	2 - MED.-LOW - Yellow	1618	1604	1591	1577	1563	1539	1515	1466	1416
	1 - LOW - Red	1334	1331	1327	1320	1313	1290	1266	1229	1192
*UH1C100A9481A	4 - HIGH - Black	1982	1912	1836	1761	1679	1593	1496	1389	1267
	3 - MED.-HIGH - Blue	1892	1832	1765	1696	1621	1538	1446	1342	1205
	2 - MED.-LOW - Yellow	1759	1712	1660	1604	1536	1465	1383	1275	1149
	1 - LOW - Red	1593	1557	1521	1485	1433	1370	1294	1182	1068
*UH1D100A9601A	4 - HIGH - Black	2339	2287	2235	2168	2100	2021	1941	1858	1773
	3 - MED.-HIGH - Blue	2045	2021	1996	1947	1897	1836	1774	1701	1629
	2 - MED.-LOW - Yellow	1719	1703	1693	1671	1649	1607	1565	1498	1431
	1 - LOW - Red	1436	1430	1430	1414	1398	1372	1344	1287	1230
*UH1D120A9601A	4 - HIGH - Black	2380	2334	2287	2241	2193	2118	2043	1956	1870
	3 - MED.-HIGH - Blue	2042	2029	2016	1984	1952	1892	1830	1771	1712
	2 - MED.-LOW - Yellow	1695	1690	1684	1668	1652	1627	1601	1545	1489
	1 - LOW - Red	1402	1404	1406	1397	1387	1358	1328	1285	1242

*= First letter may be "A" or "T"

CFM VS. TEMPERATURE RISE																			
MODEL	Cubic Feet Per Minute (CFM)																		
	600	700	800	900	1000	1100	1200	1300	1400	1500	1600	1700	1800	1900	2000	2100	2200	2300	2400
*UH1B040A9241A	59	50	44	39	35														
*UH1B060A9361A				59	53	48	44	41	38										
*UH1B080A9421A						64	59	54	50	47	44	41							
*UH1C080A9601A						64	59	54	50	47	44	41							
*UH1C100A9481A								68	63	59	55	52	49	46	44				
*UH1D100A9601A								68	63	59	55	52	49	46	44	42	40	38	37
*UH1D120A9601A										70	66	62	59	56	53	50	48	46	44

*= First letter may be "A" or "T"

Service Facts

FURNACE AIRFLOW (CFM) VS. EXTERNAL STATIC PRESSURE (in. w.c.)										
MODEL	SPEED TAP	0.10	0.20	0.30	0.40	0.50	0.60	0.70	0.80	0.90
*DH1B040A9241A	4 - HIGH - Black	998	965	922	870	807	735	653	561	459
	3 - MED.-HIGH - Blue	856	832	797	751	695	628	550	462	363
	2 - MED.-LOW - Yellow	753	728	694	650	596	533	460	378	286
	1 - LOW - Red	647	617	581	538	490	435	375	308	235
*DH1B065A9421A	4 - HIGH - Black	1501	1453	1402	1344	1283	1216	1145	1068	986
	3 - MED.-HIGH - Blue	1442	1393	1341	1285	1227	1166	1103	1037	968
	2 - MED.-LOW - Yellow	1346	1308	1263	1212	1155	1092	1024	950	869
	1 - LOW - Red	1225	1197	1160	1116	1062	1001	931	853	766
*DH1C085A9481A	4 - HIGH - Black	1835	1772	1709	1637	1566	1485	1405	1313	1222
	3 - MED.-HIGH - Blue	1726	1674	1622	1557	1492	1416	1340	1252	1164
	2 - MED.-LOW - Yellow	1581	1539	1498	1440	1383	1321	1258	1172	1085
	1 - LOW - Red	1401	1374	1346	1308	1269	1209	1148	1075	1001
*DH1D110A9601A	4 - HIGH - Black	2147	2074	2000	1941	1881	1807	1732	1655	1576
	3 - MED.-HIGH - Blue	1995	1940	1885	1827	1767	1699	1631	1547	1462
	2 - MED.-LOW - Yellow	1712	1681	1649	1602	1555	1505	1455	1381	1307
	1 - LOW - Red	1424	1408	1392	1367	1341	1296	1251	1188	1124

*= First letter may be "A" or "T"

CFM VS. TEMPERATURE RISE																	
MODEL	Cubic Feet Per Minute (CFM)																
	600	700	800	900	1000	1100	1200	1300	1400	1500	1600	1700	1800	1900	2000	2100	2200
*DH1B040A9241A	59	50	44	39	35												
*DH1B065A9421A		75	66	59	53	48	44	41	38	35							
*DH1C085A9481A					70	64	59	54	50	47	44	41	39	37			
*DH1D110A9601A						88	81	74	69	65	60	57	54	51	48	46	

*= First letter may be "A" or "T"

Troubleshooting Flowchart Index

- 14) IFC Component Layout
- 15) LED Flash Codes
- 16) Getting started
- 17) 2 Flash Troubleshooting Retry and Recycle Lockout
- 19) 3 Flash Troubleshooting Pressure Switch Fault
- 20) 4 Flash Troubleshooting High Limit and Auxiliary Limit
- 21) 4 Flash Troubleshooting Roll Out Limit
- 22) 5 Flash Troubleshooting Flame Sensed Fault
- 23) 6 Flash Troubleshooting Polarity Reversed or Poor Ground Fault
- 24) 7 Flash Troubleshooting External Gas Valve Circuit Fault
- 25) 8 Flash Troubleshooting Low Flame Sense Fault
- 26) 9 Flash Troubleshooting Igniter Faults
- 27) Furnace PSC Fan Motor – No Air Flow

The following pages include troubleshooting flowcharts in reference to the 95% Single Stage furnaces ONLY; using the FAULT LED as starting points.

The information contained is for reference only and does not cover all scenarios or problems that may be encountered by a qualified field technician.

Only qualified technicians should attempt to install, troubleshoot, or repair this appliance. Failure to follow all cautions and/or warnings could result in personal or property damage; including death.

Service Facts

Integrated Furnace Control (IFC) Component Layout

Single Stage 95% Condensing Furnace -
Integrated Furnace Control (IFC) Component Layout

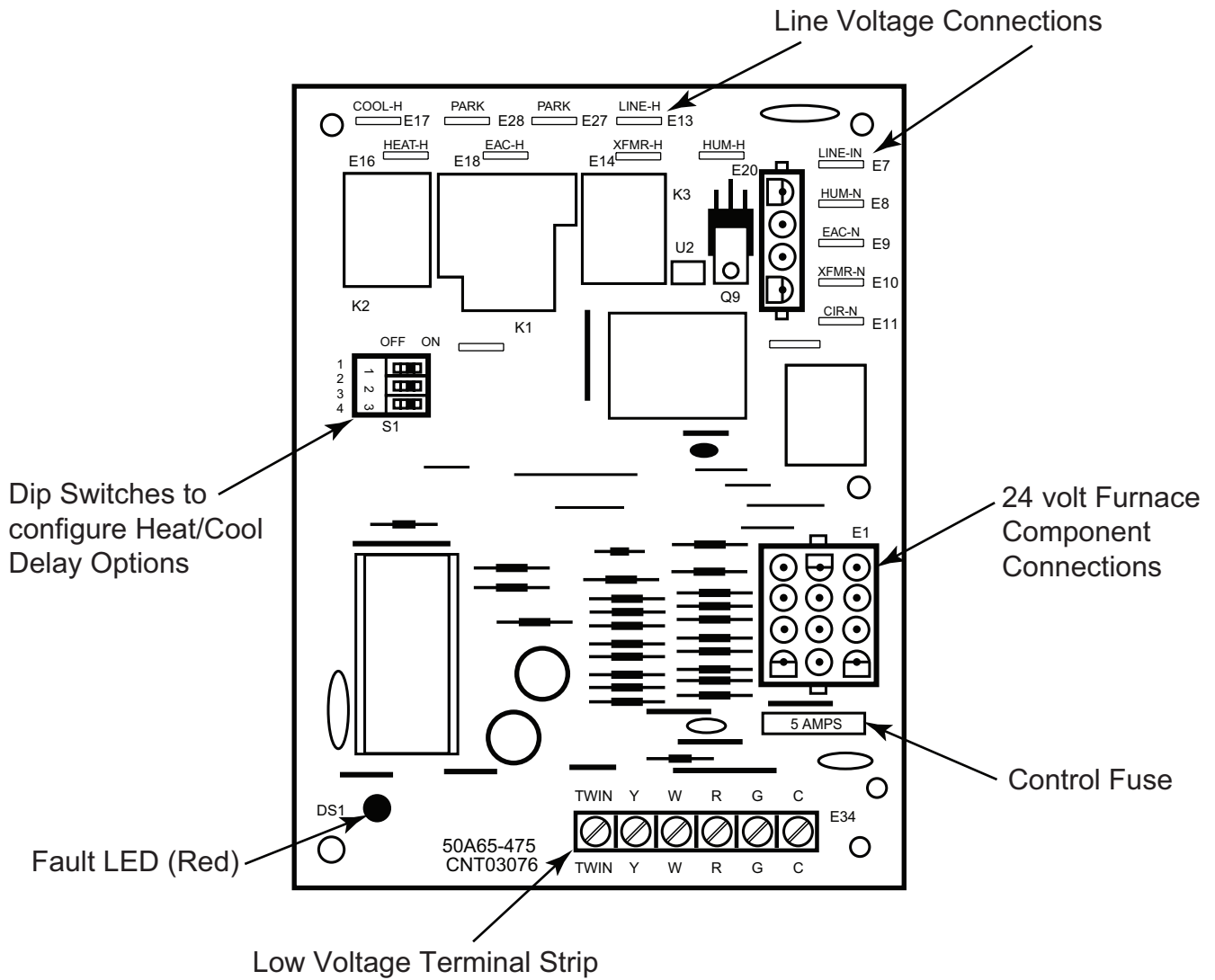

Downflow Models
use control board
50A65-477
CNT05995

Fault LED Flash Codes Definitions

INTEGRATED FURNACE CONTROL ERROR FLASH CODES	
Flashing Slow ---	Normal - No call for Heat
Flashing Fast ---	Normal - Call for Heat
Continuous ON ---	Replace IFC
Continuous OFF ---	Check Power
2 Flashes ---	System Lockout (Retries or Recycles exceeded)
3 Flashes ---	Pressure Switch Error
4 Flashes ---	Open High Limit Device
5 Flashes ---	Flame sensed when no flame should be present
6 Flashes ---	115 Volt AC power reversed or Poor Grounding
7 Flashes ---	Gas valve circuit error
8 Flashes ---	Low flame sense signal
9 Flashes ---	Check Ignitor

Service Facts

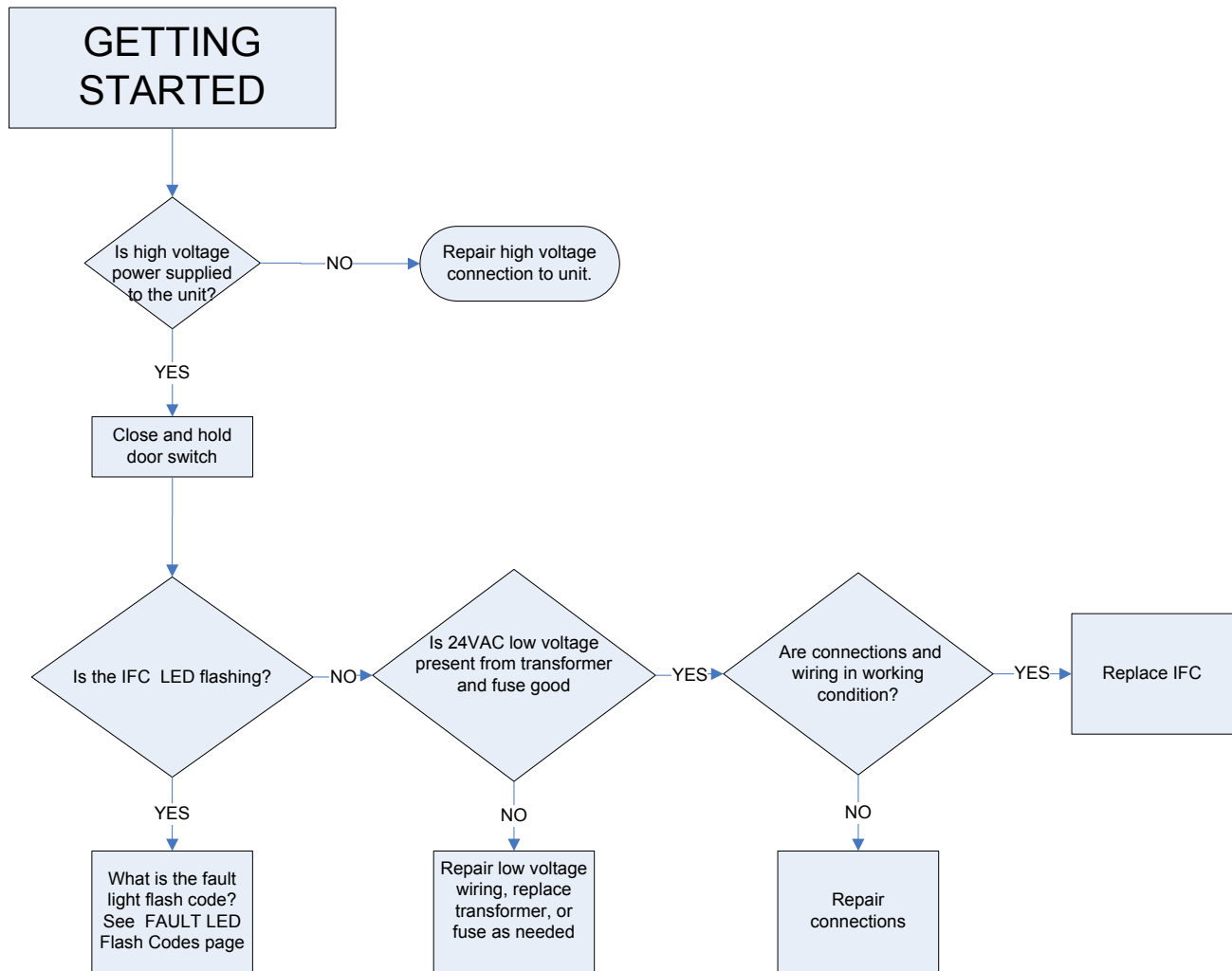

Refer to Gas Furnace Silicon Nitride Ignitor Models Service Manual to supplement this information.
Publication Number 34-3405-08

DEFINITION

RETRY Lock Out = 3 unsuccessful tries for ignition within a single call for heat
Flame has never been sensed

RECYCLE Lock Out = 10 recycles within a single call for heat.
Flame is sensed & then lost

2 Flash Fault LED

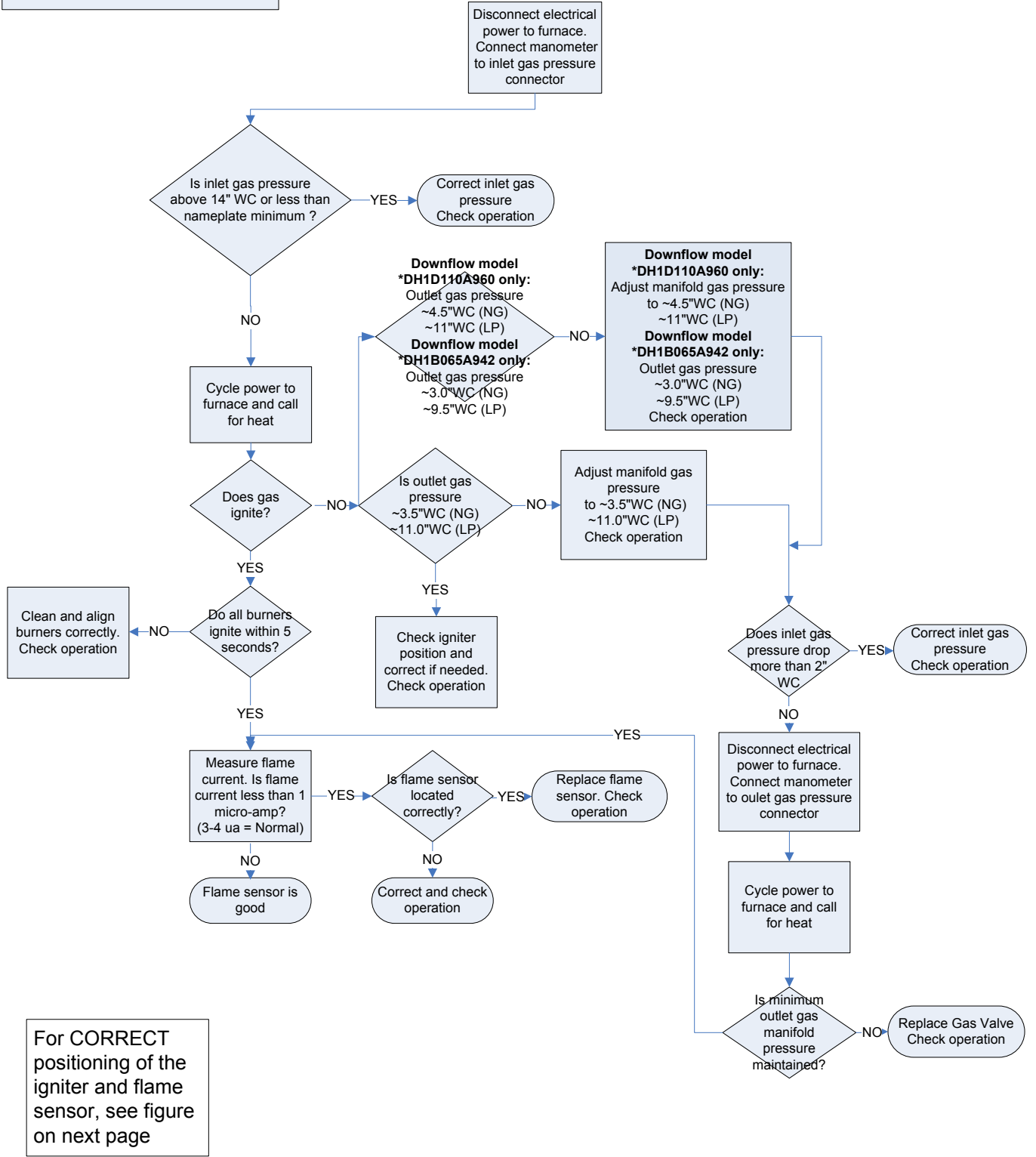

For CORRECT positioning of the igniter and flame sensor, see figure on next page

Service Facts

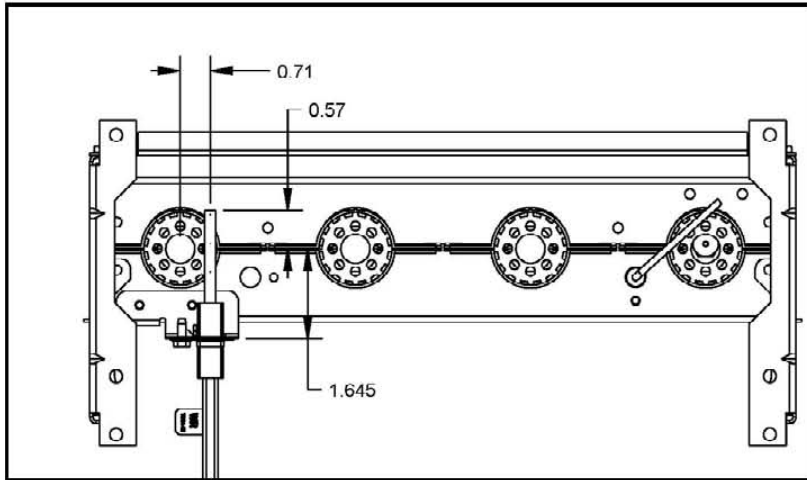

Correct positioning of ignitor and flame sensor.
NOTE the slight overlap of the ignitor and the burner

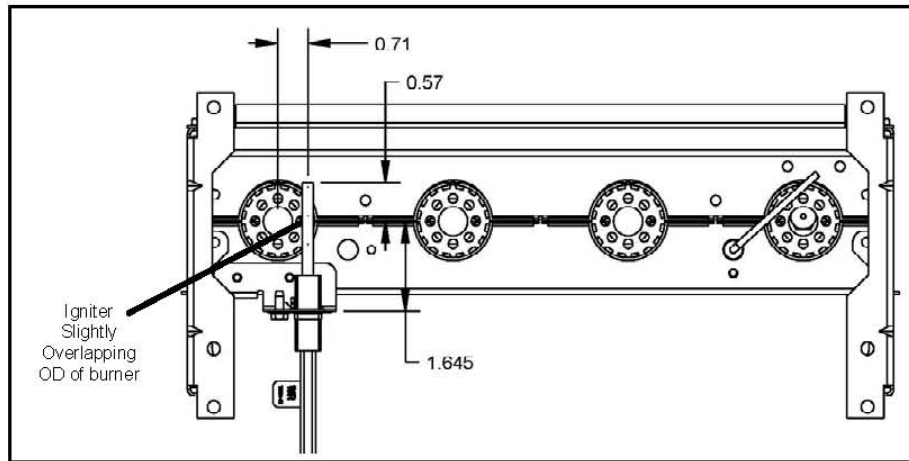

INCORRECT positioning of ignitor.
HOT ZONE must be centered over the cross-over
Ignitor not overlapping burner (see above)

DEFINITION
 An error has occurred with the P.S.
 The error will be reported, indicating that
 the pressure switch is either opened or
 closed, contrary to normal operating
 sequence.
**In most cases, the pressure switch is
 not the problem.**
Note: Verify all wiring to
 pressure switch is correct per
 wiring diagram

3 Flash Fault LED

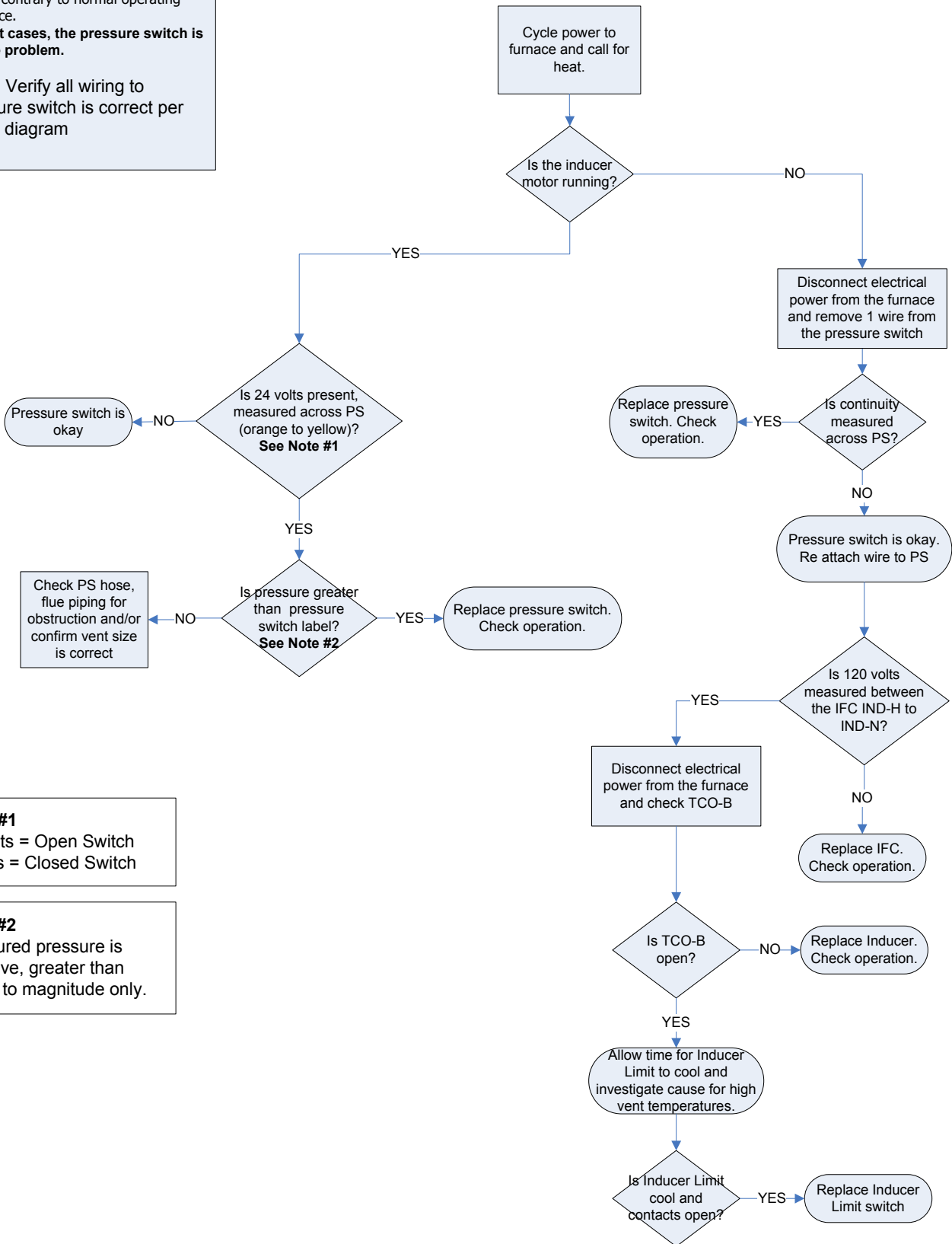

Note #1
 24 volts = Open Switch
 0 volts = Closed Switch

Note #2
 Measured pressure is negative, greater than refers to magnitude only.

Service Facts

DEFINITION

Limit switches are safety devices that will open when an abnormal high temperature has been sensed.
REMOVE ALL JUMPER WIRING TO SWITCHES!
 Under no circumstances, shall these switches be left jumpered when not troubleshooting.

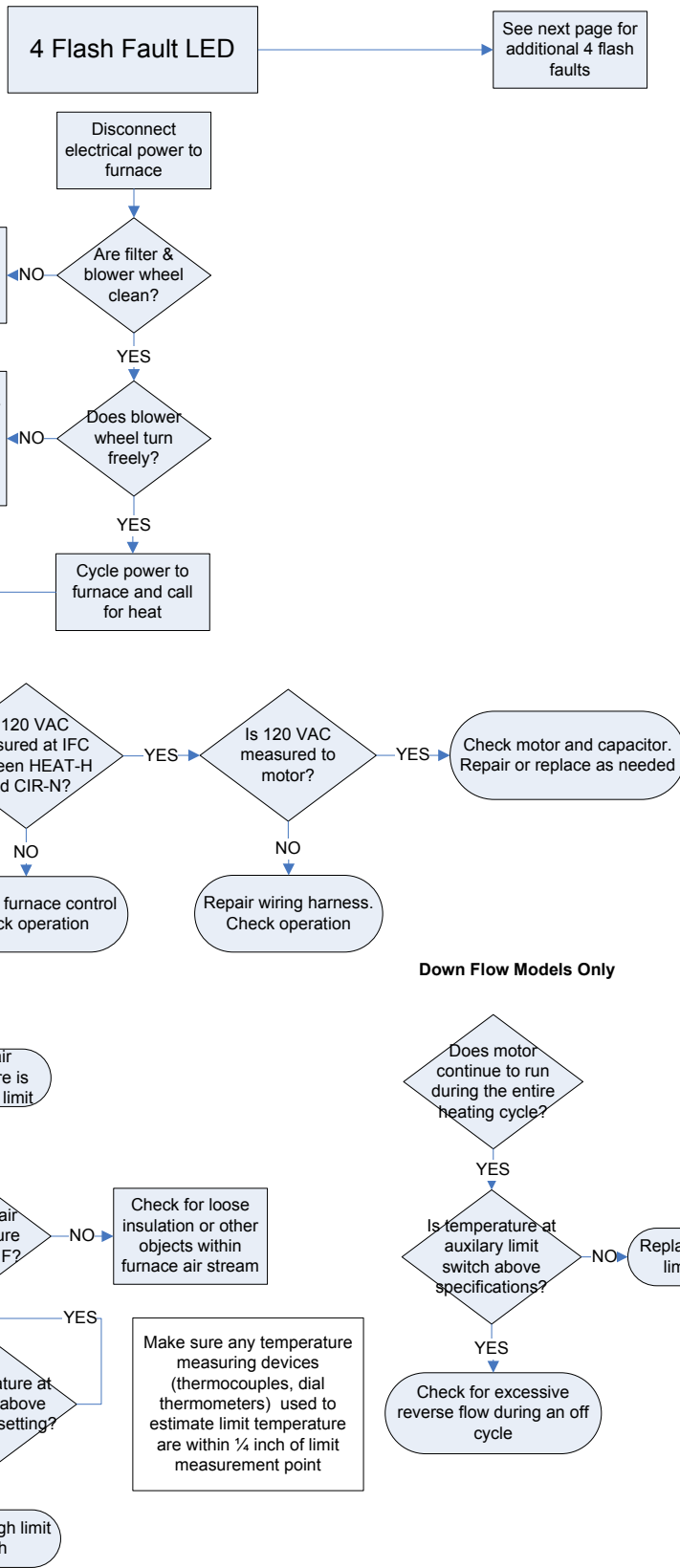

DEFINITION:

Limit switches are safety devices that will open when an abnormal high temperature has been sensed.
REMOVE ALL JUMPER WIRING TO SWITCHES!
 Under no circumstances, shall these switches be left jumpered when not troubleshooting.

4 Flash Fault LED

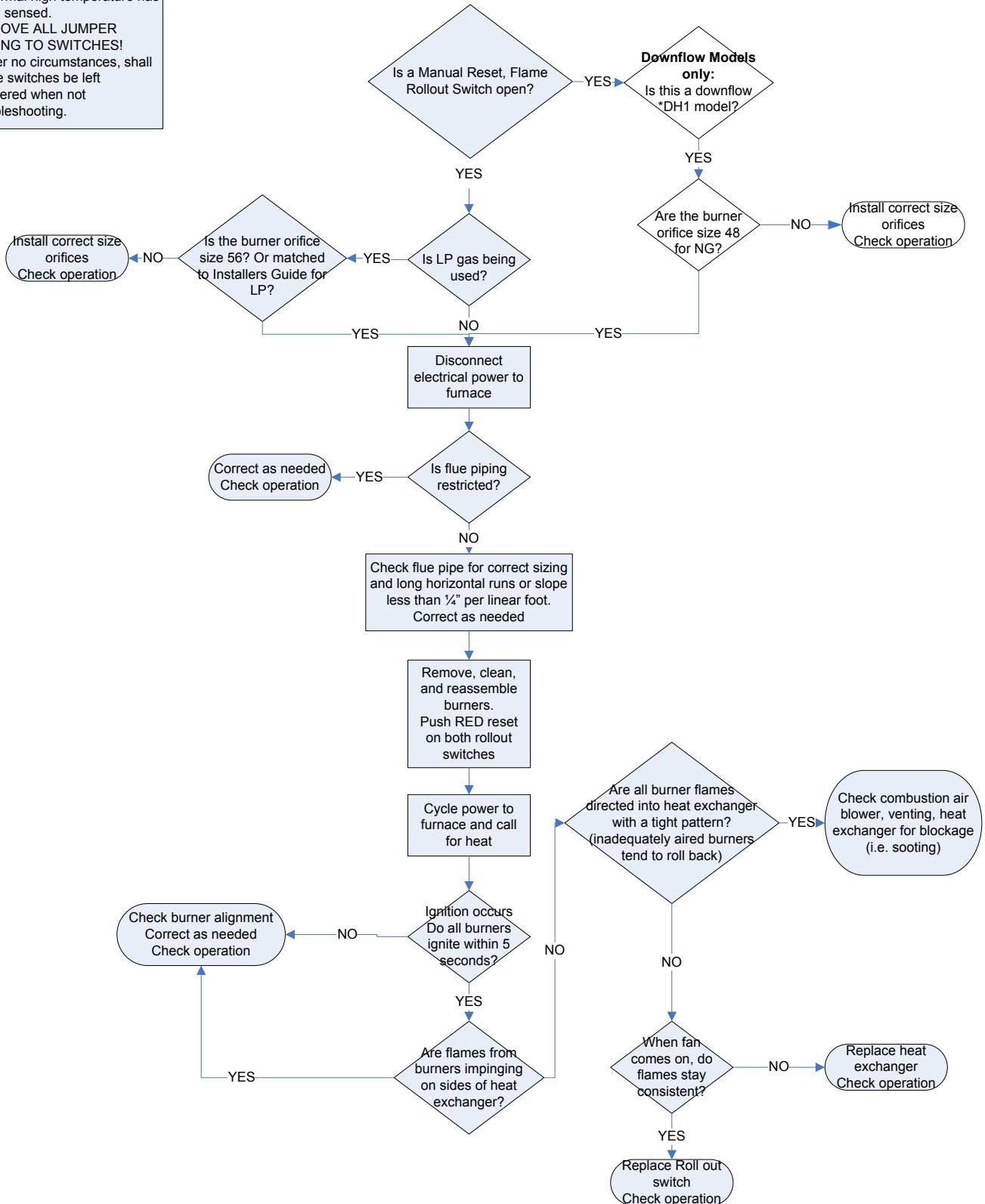

Service Facts

DEFINITION:
Flame is sensed when it should not be sensed.

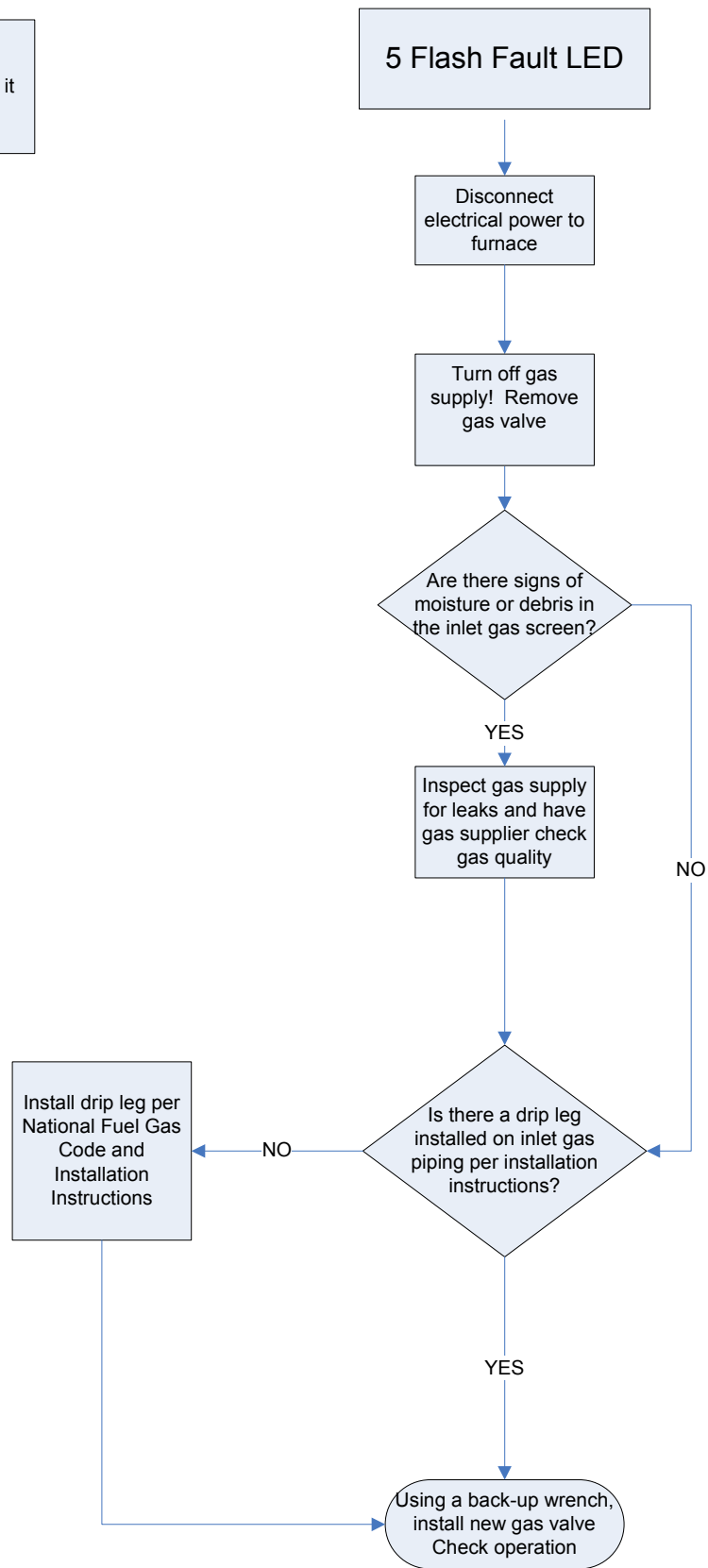

DEFINITION:
 Ground Fault - Incoming or chassis ground connection is not sensed
 Polarity Fault – Incoming high voltage wiring is reversed
 Line Voltage Too Low - Line voltage must not be below 97 VAC

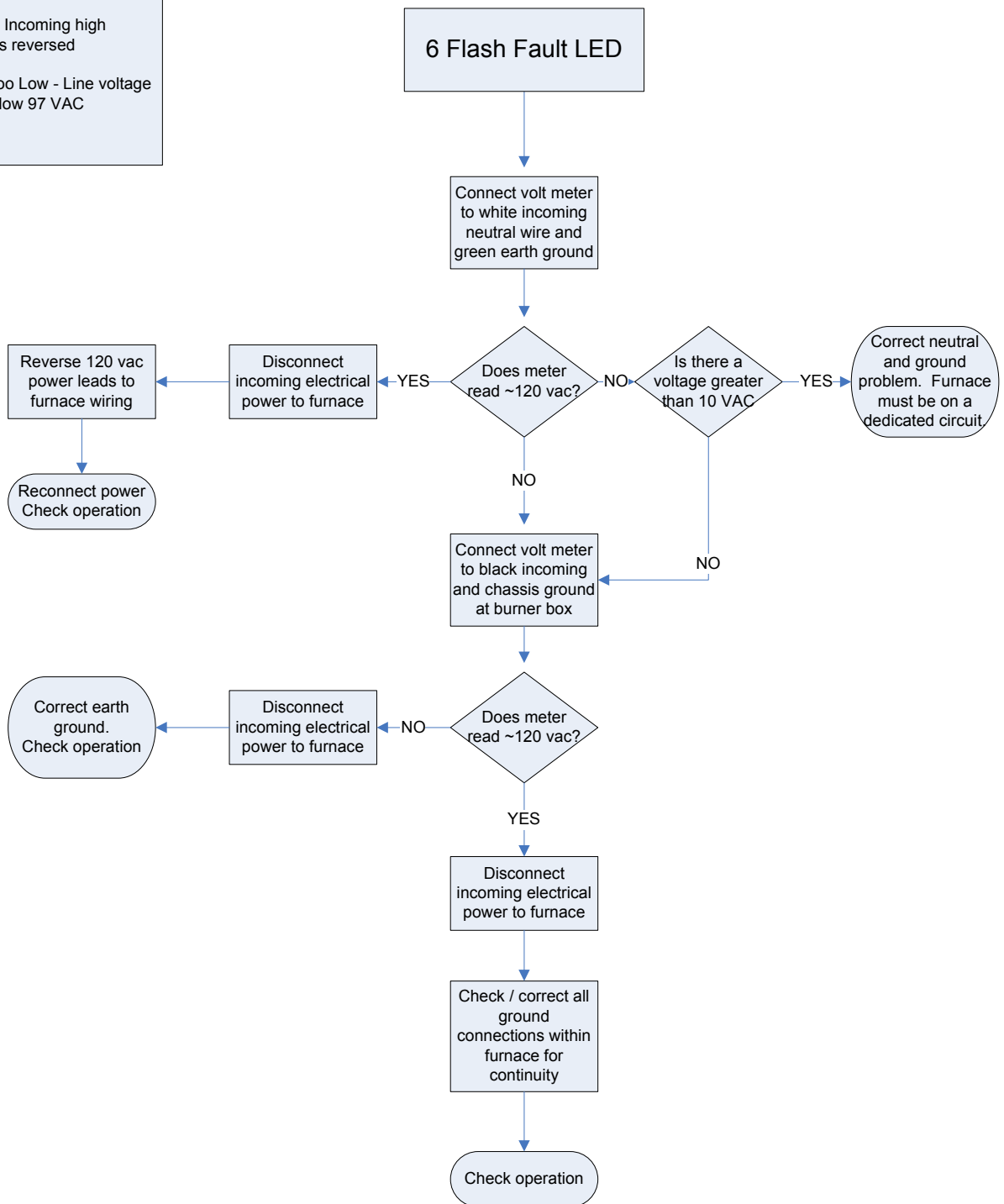

DEFINITION: External Gas Valve Circuit Error (24 volts is present when it should not be present)

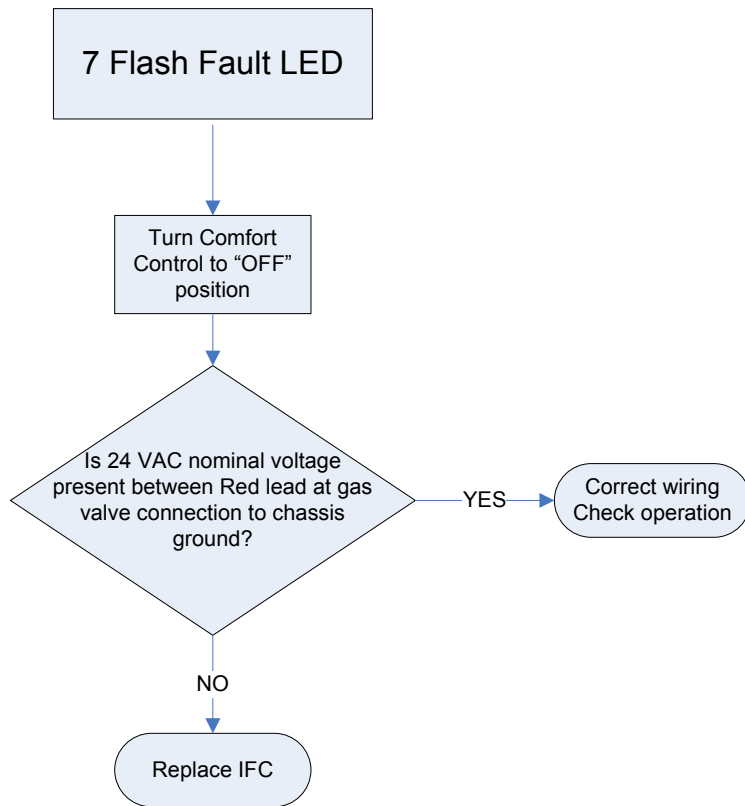

DEFINITION:
The flame sense current is less than 1 micro-amp DC

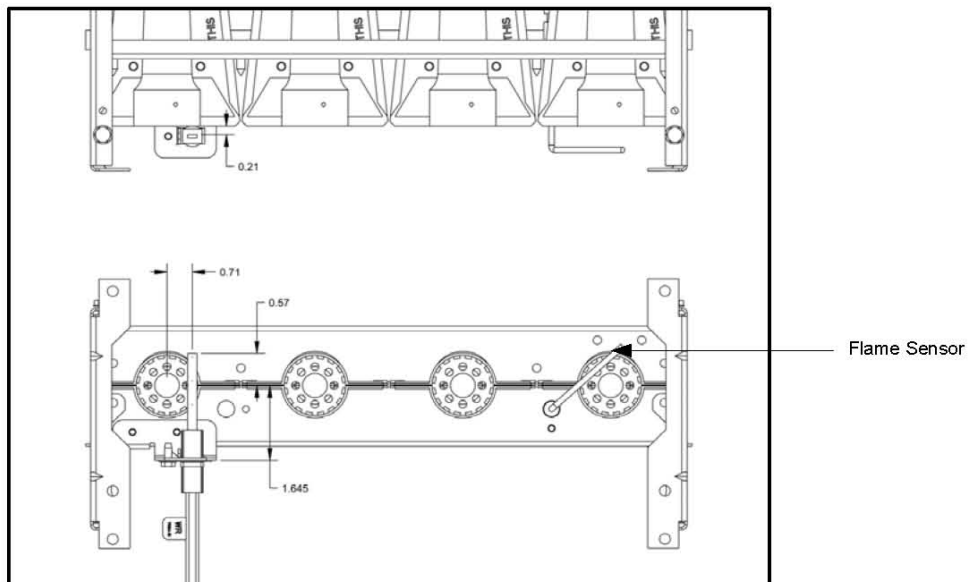
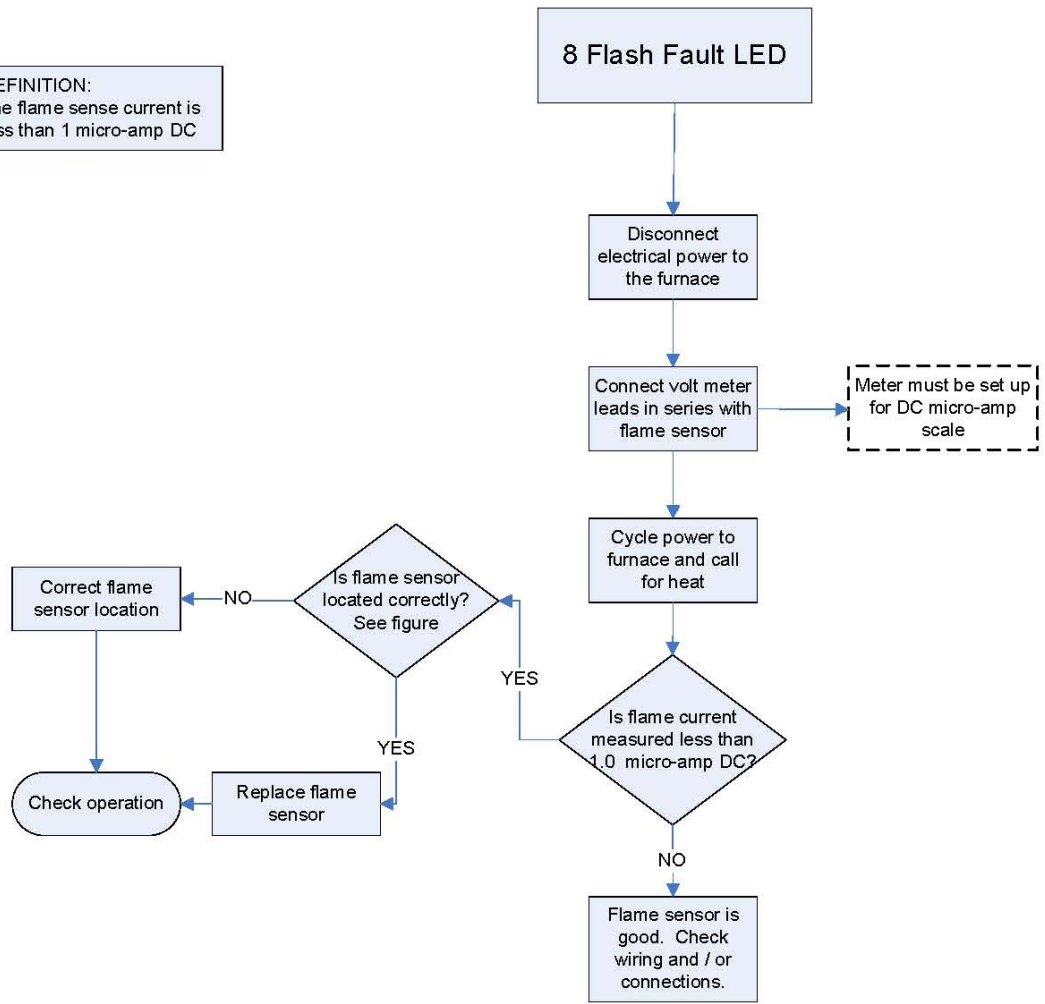

Service Facts

DEFINITION:

Triac Fault – The triac reduces voltage applied to the ignitor. A voltage error has been sensed

Ignitor Fault – The control board has sensed that the ignitor circuit is open or shorted. The Ignition system is very dependent on good earth ground connections. A poor earth ground can result in multiple ignitor and/or triac failures.

9 Flash Fault LED

Disconnect electrical power to the furnace

Disconnect ignitor and check resistance of ignitor

Is resistance reading between 11 – 18 ohms?

YES

Check Triac Is it damaged?

NO

Check all wiring for insulation damage and connection integrity

Is there wiring or insulation damage?

YES

Repair or replace wiring. Check operation

Verify all ground connections

Replace ignitor. Check operation

Verify all ground connections. Check ignitor for wire insulation damage.

Replace the IFC. Check operation

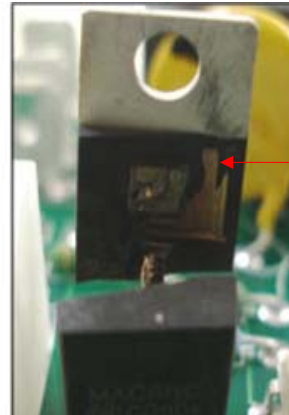

Damaged Triac

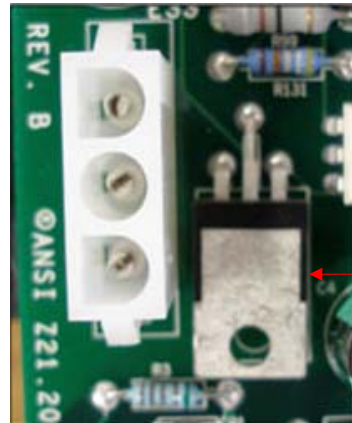

Good Triac

TROUBLESHOOTING

Furnace PSC fan motor - No Air Flow

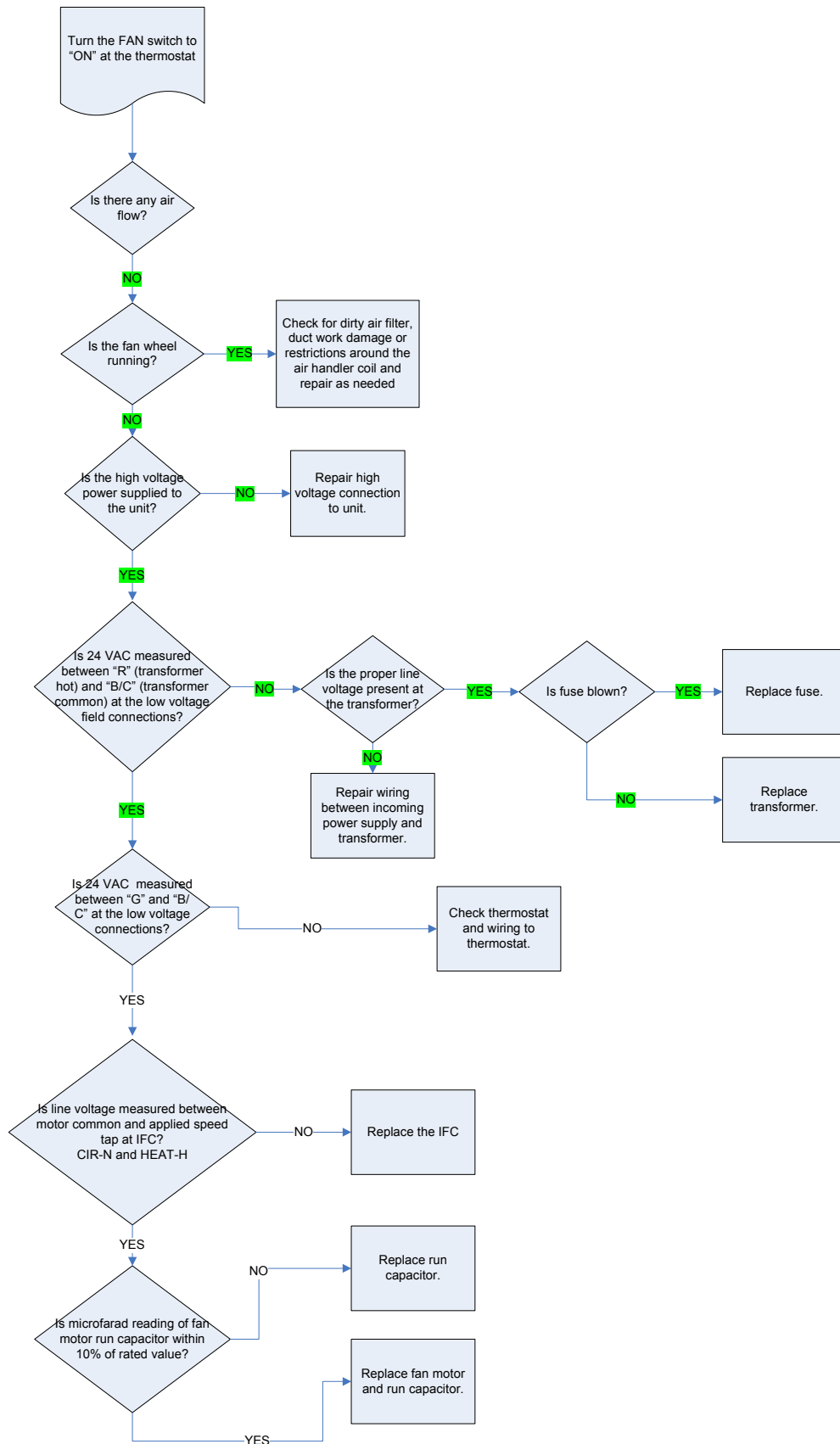

Service Facts

Trane
6200 Troup Highway
Tyler, TX 75707

*For more information contact
your local dealer (distributor)*

Literature Order Number	UH1-DH1-SF-1F
File Number	UH1-DH1-SF-1F
Supersedes	UH1-DH1-SF-1E
Date	01/12

Since the manufacturer has a policy of continuous product and product data improvement, it reserves the right to change design and specifications without notice.