

Keysight Technologies

PNA Family

Microwave Network Analyzers

(N522x/3x/4xB)

Configuration Guide



Table of Contents

PNA Family Network Analyzer Configurations	5
Test set and power configuration options	5
Hardware options	6
Application software	6
Accessories, calibration options	8
PNA-X Series Test Set and Power Configuration Options	9
PNA Series Test Set and Power Configuration Options	14
PNA-L Series Test Set and Power Configuration Options	17
PNA Family Application Options	18
Measurement application software	18
Noise figure options and applications	21
PNA-X block diagrams with noise figure option	22
Noise figure measurement summary	23
Pulse, antenna, mm-wave applications and options	24
Nonlinear vector network analysis	24
Accessories	25
PNA Family Network Analyzer Upgrade Kits	26
Frequency, test ports, test set and power configurations	26
Upgrade paths	27
Applications	28
Material measurements	28
Signal integrity measurements	28
Multiport measurements	28
Millimeter-wave measurements	29
Measurement Accessories	30
Cables and adapter sets	30
Calibration kits	30
For devices with 1.0 mm connectors	31
For devices with 1.85 mm connectors	31
For devices with 2.4 mm connectors	32
For devices with K (2.92 mm) connectors	32
For devices with 3.5 mm or SMA connectors	33
For devices with Type-N connectors	35
For devices with 7 mm connectors	36
For devices with waveguide	36
Verification kits	37
General Accessories	37
Spare drive	37
Probe	38
Power meters and sensors	38
Comb generators	38
Amplifiers	38
Couplers	38
Equipment rack accessories	38
Monitors	38
Interface cables	38

This configuration guide describes standard configurations, options, accessories, upgrade kits and compatible peripherals for the PNA Family microwave network analyzers. This guide should be used with the Keysight Technologies, Inc. PNA Family data sheets for a complete description of these analyzers.



PNA-X Series

- N5249B 10 MHz to 8.5 GHz
- N5241B 10 MHz to 13.5 GHz
- N5242B 10 MHz to 26.5 GHz
- N5244B 10 MHz to 43.5 GHz
- N5245B 10 MHz to 50 GHz
- N5247B 10 MHz to 67 GHz

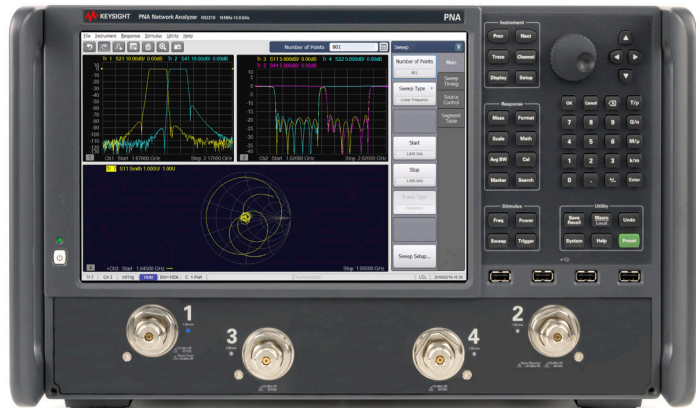

PNA Series

- N5221B 10 MHz to 13.5 GHz
- N5222B 10 MHz to 26.5 GHz
- N5224B 10 MHz to 43.5 GHz
- N5225B 10 MHz to 50 GHz
- N5227B 10 MHz to 67 GHz



PNA-L Series

- N5239B 300 kHz to 8.5 GHz
- N5231B 300 kHz to 13.5 GHz
- N5232B 300 kHz to 20 GHz
- N5234B 10 MHz to 43.5 GHz
- N5235B 10 MHz to 50 GHz



Keysight offers the following options for all PNA Family network analyzers

Certification options

Commercial calibration certification with test data (Option UK6)
Complete set of measurements which tests unit to manufacturer's published specifications. Includes calibration label, calibration certificate, and data report. Conforms to ISO 9001.

ISO 17025 compliant calibration (Option 1A7)

Complete set of measurements which tests unit to manufacturer's published specifications. Includes calibration label, ISO 17025 calibration certificate, and data report, measurement uncertainties and guardbands on all customer specifications. Conforms to ISO 17025 and ISO 9001.

ANSI Z540 compliant calibration (Option A6J)

Complete set of measurements which tests unit to manufacturer's published specifications. Includes pre- and post-adjustment data with measurement uncertainty information compliant to the ANSI/NCSL Z540 standard.

Warranty and service

3- and 5-year warranty and service plans are available at the time of instrument purchase. Standard warranty is 3 years.

Documentation

The PNA Series instruments are equipped with an Online Help system available within the instrument in English only. All PNA documentation is available on the web:

www.keysight.com/find/pna

Calibration Software Licenses

Built-in performance test software for standard compliant cal (S93898A)

Adds built-in performance testing and calibration software for self-maintainers. Requires additional equipment. See the analyzer's Service Guide for more information on equipment required.



PNA Family Network Analyzer Configurations

PNA-X Series

N5249B 10 MHz to 8.5 GHz
 N5241B 10 MHz to 13.5 GHz
 N5242B 10 MHz to 26.5 GHz
 N5244B 10 MHz to 43.5 GHz
 N5245B 10 MHz to 50 GHz
 N5247B 10 MHz to 67 GHz

PNA Series

N5221B 10 MHz to 13.5 GHz
 N5222B 10 MHz to 26.5 GHz
 N5224B 10 MHz to 43.5 GHz
 N5225B 10 MHz to 50 GHz
 N5227B 10 MHz to 67 GHz

PNA-L Series

N5239B 300 kHz to 8.5 GHz
 N5231B 300 kHz to 13.5 GHz
 N5232B 300 kHz to 20 GHz
 N5234B 10 MHz to 43.5 GHz
 N5235B 10 MHz to 50 GHz

Test set and power configuration options

Choose one test set and power configuration option. Option 2xx indicates two test ports. Option 4xx indicates four test ports. To add options to a product, order the corresponding item number (N52xxB-xxx).

Description	Configurable Test Set	Source Attenuators	Receiver Attenuators	Bias-tees	Internal Second Source	Internal Combiner	Mechanical Switches	Low-Frequency Extension	Additional Information
PNA-X Series									
Option 201	●								
Option 217	●	●	●						Not available on 67 GHz model
Option 219	●	●	●	●					
Option 222 ¹	●	●	●		●	●	●		Not available on 67 GHz model
Option 224 ¹	●	●	●	●	●	●	●		
Option 401 ¹	●				●				
Option 417 ¹	●	●	●		●				Not available on 67 GHz model
Option 419 ¹	●	●	●	●	●				
Option 422 ¹	●	●	●		●	●	●		Not available on 67 GHz model
Option 423 ¹	●	●	●	●	●	●	●		
Option 425 ¹	●	●	●	●	●	●	●	●	Only available on N5242/47B ²
PNA Series									
Option 200									
Option 201	●								
Option 205	●			●				●	Only available on N5222/27B
Option 210									2-port metrology option
Option 217	●	●	●						Not available on 67 GHz model
Option 219	●	●	●	●					
Option 400 ¹					●				
Option 401 ¹	●				●				
Option 410 ¹					●				4-port metrology option
Option 417 ¹	●	●	●		●				Not available on 67 GHz model
Option 419 ¹	●	●	●	●	●				
PNA-L Series									
Option 200									
Option 216	●	●							
Option 400									Available on only N5231/32B
Option 416 ³	●	●							Available on only N5231/32B

- To independently control the frequency of the second internal source, one of the following software applications is required: S93080/029/082/083/084/086/087/089/090x/093/094A, and S94510/511A.
- For N5242B, Option 425 is available with or without low-noise receiver Option 029. For N5247B, Option 425 is only available with Option 029.
- Adds one source attenuator to be shared with all test ports.



PNA Family Network Analyzer Configurations (continued)

PNA-X Series	PNA Series	PNA-L Series
N5249B 10 MHz to 8.5 GHz	N5221B 10 MHz to 13.5 GHz	N5239B 300 kHz to 8.5 GHz
N5241B 10 MHz to 13.5 GHz	N5222B 10 MHz to 26.5 GHz	N5231B 300 kHz to 13.5 GHz
N5242B 10 MHz to 26.5 GHz	N5224B 10 MHz to 43.5 GHz	N5232B 300 kHz to 20 GHz
N5244B 10 MHz to 43.5 GHz	N5225B 10 MHz to 50 GHz	N5234B 10 MHz to 43.5 GHz
N5245B 10 MHz to 50 GHz	N5227B 10 MHz to 67 GHz	N5235B 10 MHz to 50 GHz
N5247B 10 MHz to 67 GHz		

Hardware options

Description	For PNA-X Series	For PNA Series	For PNA-L Series	Additional Information
Add IF inputs	N524xB-020	N522xB-020	n/a	Used for antenna measurements and mm-wave extenders
Add pulse modulator to first source	N524xB-021	N522xB-021	n/a	
Add pulse modulator to second source	N524xB-022	N522xB-022	n/a	Requires one of Option 22x, 40x, 41x, or 42x
Add low-noise receiver	N524xB-029	n/a	n/a	S93029A application software is needed to control the noise receiver for noise figure and noise power measurements. For N5241/42/49B, requires one of options 21x, 22x, 41x, or 42x. For N5244/45/47B, requires one of options 22x or 42x. On N5247B, noise receiver works up to 50 GHz only.

Application software¹

Description	For PNA-X Series	For PNA Series	For PNA-L Series	Additional Information
Automatic fixture removal	S93007A	S93007A	S93007A	
Time domain analysis	S93010A	S93010A	S93010A	
Dynamic uncertainty for S-parameter measurements	S93015A	S93015A	S93015A ⁵	Displays the measurement uncertainty dynamically (real-time) on the measurement trace.
Basic pulsed-RF measurements	S93025A	S93025A	n/a	Includes control of internal pulse generators and provides pulse widths to 200 ns using wideband detection
Advanced pulsed-RF measurements	S93026A	S93026A	n/a	Includes control of internal pulse generators, and provides pulse widths to 100 ns using wideband detection, and 20 ns using narrowband detection
Noise figure measurements with vector correction ²	S93029A	S93029A	n/a	Standard receivers are used if hardware option N524xB-029 is not present
Frequency-offset measurements	S93080A	S93080A	S93080A	Provides ability to independently set the frequency of internal sources and receivers, and to configure external sources. This functionality is included with S93029/082/083/084/086/087/089/090x/093/094A, and S94510/511A.
Scalar mixer/converter measurements	S93082A	S93082A	S93082A	Provides SMC measurement class. S93082A is a subset of S93083A.
Vector and scalar mixer/converter measurements ³	S93083A	S93083A	n/a	Provides SMC+Phase and VMC measurement classes
Embedded-LO capability	S93084A	S93084A	n/a	Works with S93029/082/083/086/087A
Gain-compression measurements	S93086A	S93086A	n/a	
Intermodulation distortion measurements ⁴	S93087A	S93087A	n/a	Not available with PNA test set options 200, 210, 400, and 410
Source phase control	S93088A	S93088A	n/a	
Differential and I/Q device measurements	S93089A	S93089A	n/a	Requires a 4-port test set option (4xx)

- Supported software license types: fixed-perpetual (1FP), transportable-perpetual (1TP), fixed-1-year (1FY), and transportable-1-year (1TY)
- For N522xB and N5241/42/49B, vector-noise-corrected measurements require an ECal for use as an impedance tuner. For N5244/45/47B with Option 029, an internal tuner is included. Noise calibration requires a power meter when using a standard receiver. When using the low-noise receiver (Option 029), either a power meter or a 346-series noise source is required (Keysight 346C or 346C-K01 recommended). A power meter is required for measuring mixers and converters.
- A configurable test set is required for VMC measurements to connect a reference mixer, or for SMC+Phase measurements using the comb-generator-based calibration. When ordered with PNA test set Options 200, 210, 400, or 410 (no front-panel jumpers), phase and delay measurements can only be done using SMC+Phase with a calibration mixer.
- S93087A can be used without PNA-X Options 22x or 42x, but external equipment such as a signal generator and a combiner may be required. Refer to page 19 for more details.
- S93015A is not available on N5231B and N5232B.



PNA Family Network Analyzer Configurations (continued)

PNA-X Series

N5249B 10 MHz to 8.5 GHz
 N5241B 10 MHz to 13.5 GHz
 N5242B 10 MHz to 26.5 GHz
 N5244B 10 MHz to 43.5 GHz
 N5245B 10 MHz to 50 GHz
 N5247B 10 MHz to 67 GHz

PNA Series

N5221B 10 MHz to 13.5 GHz
 N5222B 10 MHz to 26.5 GHz
 N5224B 10 MHz to 43.5 GHz
 N5225B 10 MHz to 50 GHz
 N5227B 10 MHz to 67 GHz

PNA-L Series

N5239B 300 kHz to 8.5 GHz
 N5231B 300 kHz to 13.5 GHz
 N5232B 300 kHz to 20 GHz
 N5234B 10 MHz to 43.5 GHz
 N5235B 10 MHz to 50 GHz

Application software¹ (continued)

Description	For PNA-X Series	For PNA Series	For PNA-L Series	Additional Information
Spectrum analysis, up to 8.5 GHz ²	S930900A	S930900A	S930900A	
Spectrum analysis, up to 13.5 GHz ²	S930901A	S930901A	S930901A	
Spectrum analysis, up to 26.5 GHz ²	S930902A	S930902A	S930902A	
Spectrum analysis, up to 43.5 GHz ²	S930904A	S930904A	S930904A	
Spectrum analysis, up to 50 GHz ²	S930905A	S930905A	S930905A	
Spectrum analysis, up to 67 GHz ²	S930907A	S930907A	n/a	
Spectrum analysis, up to 90 GHz ²	S930909A	S930909A	n/a	
Spectrum analysis, up to 120 GHz	S93093A	S93093A	n/a	
Spectrum analysis, beyond 120 GHz	S93094A	S93094A	n/a	
Fast CW measurements	S93118A	S93118A	n/a	
True-mode stimulus	S93460A	S93460A	n/a	Requires a 4-port test set option (4xx)
N-port measurements ³	S93551A ⁴	S93551A	S93551A	Not available with test set options 200, 210, 400, and 410
Nonlinear vector network analysis⁵				
Nonlinear component characterization	S94510A ⁶	n/a	n/a	Requires test set option 41x or 42x
Nonlinear component characterization	S94511A ⁶	n/a	n/a	Export-control version. Requires test set option 41x or 42x
Nonlinear X-parameters ^{8,9}	S94514A ⁷	n/a	n/a	Requires test set option 42x and application software S94510A or S94511A
Nonlinear pulse-envelope domain	S94518A	n/a	n/a	Requires hardware option 021 and application software S94510A or S94511A, and S93025A or S93026A
Arbitrary load-impedance X-parameters ^{8,9}	S94520A	n/a	n/a	Requires application software S94514A and an additional load-control application.
Arbitrary load-control X-parameters ^{8,9}	S94521A	n/a	n/a	Requires application software S94520A

- Supported software license types: fixed-perpetual (1FP), transportable-perpetual (1TP), fixed-1-year (1FY), and transportable-1-year (1TY) (note: S93093A, S93094A, S93898A, and S94510A have fixed-license types only).
- For use with PNA or PNA-X models, a test set with internal receiver attenuators is recommended to avoid receiver compression when measuring large input signals. For use with PNA-L models, test set option 216 or 416 is recommended so that external attenuators can be connected via the front-panel jumpers to avoid receiver compression as needed.
- When ordering a test set, select an appropriate interface kit. Refer to Multiport Measurements section on page 28 for more details.
- When N524xB is configured as a multiport analyzer using S93551A and a multiport test set, the combiner feature of Option 22x or 42x is temporarily disabled. When configured as a standalone analyzer, the combiner feature is enabled.
- A fully configured NVNA system requires two comb generators with power supplies, Keysight calibration kits (mechanical or ECal), and a power meter and sensor or USB power sensor.
- Pulse capability requires option 021 and S93025A or S93026A.
- Pulse capability requires option 021, 022 and S93025A or S93026A.
- Requires EXG, MXG, or PSG signal generator for X-parameter extraction (the PNA-X's 10 MHz reference output can be used for 10 MHz tone-spacing applications).
- X-parameters is a trademark and registered trademark of Keysight Technologies in the U.S., Europe, Japan, and elsewhere. The X-parameters format and underlying equations are open and documented. For more information, visit www.keysight.com/find/eesof-x-parameters-info.



PNA Family Network Analyzer Configurations (continued)

PNA-X Series

N5249B 10 MHz to 8.5 GHz
 N5241B 10 MHz to 13.5 GHz
 N5242B 10 MHz to 26.5 GHz
 N5244B 10 MHz to 43.5 GHz
 N5245B 10 MHz to 50 GHz
 N5247B 10 MHz to 67 GHz

PNA Series

N5221B 10 MHz to 13.5 GHz
 N5222B 10 MHz to 26.5 GHz
 N5224B 10 MHz to 43.5 GHz
 N5225B 10 MHz to 50 GHz
 N5227B 10 MHz to 67 GHz

PNA-L Series

N5239B 300 kHz to 8.5 GHz
 N5231B 300 kHz to 13.5 GHz
 N5232B 300 kHz to 20 GHz
 N5234B 10 MHz to 43.5 GHz
 N5235B 10 MHz to 50 GHz

Accessories, calibration options

Description	For PNA-X Series	For PNA Series	For PNA-L Series	Additional Information
Accessories				
Rack mount kit for use without handles	N524xB-1CM	N522xB-1CM	N523xB-1CM	
Rack mount kit for use with handles	N524xB-1CP	N522xB-1CP	N523xB-1CP	
Pulse I/O adapter	N1966A	N1966A	n/a	
Comb generator ¹	U9391C/F/G	n/a	n/a	
Calibration software				
Built-in performance test software for standard compliant calibration ²	S93898A	S93898A	S93898A	
Calibration documentation				
ISO 17025 compliant calibration	N524xB-1A7	N522xB-1A7	N523xB-1A7	
Commercial calibration certificate with test data	N524xB-UK6	N522xB-UK6	N523xB-UK6	
ANSI Z540 compliant calibration	N524xB-A6J	N522xB-A6J	N523xB-A6J	

1. A fully configured NVNA system requires two comb generators with power supplies, Keysight calibration kits (mechanical or ECal), and a power meter and sensor or USB power sensor.
2. Additional hardware required. Please refer to the analyzer's service guide for required service-test equipment.



PNA-X Series Test Set and Power Configuration Options¹

The PNA-X is an integrated vector network analyzer featuring a built-in S-parameter test set, one or two synthesized sources used for device stimulus, a solid-state drive, USB interfaces, and a 12.1" LCD touch screen display. The N5241B, N5242B, and N5249B have 50 ohm, ruggedized 3.5 mm (m) test ports. The N5244B and the N5245B have 50 ohm, ruggedized 2.4 mm (m) test ports. The N5247B has 50 ohm, ruggedized 1.85 mm (m) test ports. Included with each instrument is a mouse, keyboard (U.S. style), a 3-year return-to-Keysight service warranty, and one day of on-site productivity assistance (PS-S20-PNA).

A test set and power configuration option is mandatory, choose one of the following:

2-ports, single source, with configurable test set (Option 201)

The standard 2-port test set comes with six front-panel access loops. The loops provide access to the signal path between (a) the source output and the reference receiver, (b) the source output and directional coupler thru arm and (c) the coupled arm of the directional coupler and the port receiver. The standard test set also includes a solid-state internal RF bypass switch in the R1 reference-receiver path.

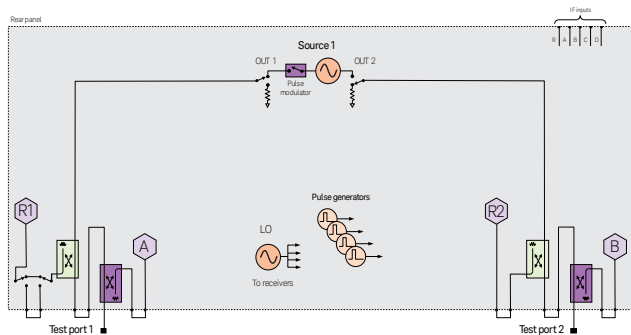

1. The block diagrams shown above include hardware that must be ordered as separate options, such as pulse modulators (Options 021 and 022), and IF access (Option 020), or is controlled by application software, as is the case for the pulse generators. In addition, the combiner type and attenuator values vary by model number. Refer to the product data sheet for the correct block diagram for a specific model.

2-ports, single source, with extended power range (Option 217)

This configuration comes with front-panel access loops, and source and receiver attenuators at each port. The source attenuators are settable in 5 dB steps up to 65 dB in N5241/42/49B, and in 10 dB steps up to 60 dB in N5244/45B. The receiver attenuators are settable in 5 dB steps up to 35 dB. The maximum power rating on the test port couplers is +43 dBm (additional attenuators or isolators are typically required to protect other components inside the instrument). Option 217 is not available on the N5247B.

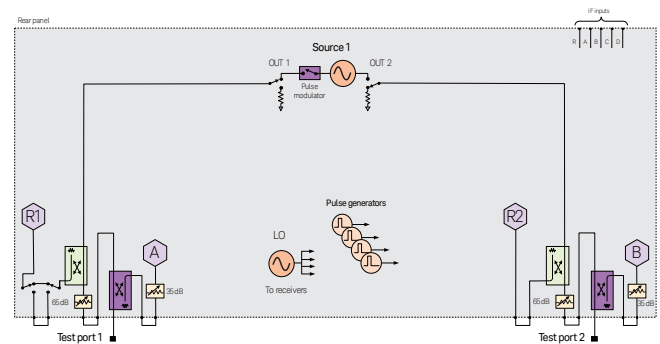

2-ports, single source, with extended power range and bias-tees (Option 219)

This configuration comes with front-panel access loops, and bias tees and source and receiver attenuators at each port. The source attenuators are settable in 5 dB steps up to 65 dB in N5241/42/49B, in 10 dB steps up to 60 dB in N5244/45B, and in 10 dB steps up to 50 dB in N5247B. The receiver attenuators are settable in 5 dB steps up to 35 dB in N5241/42/44/45/49B, and 10 dB steps up to 50 dB in N5247B. The bias tees are connected directly to the test port couplers, which limits the maximum power rating on the pair to +30 dBm (additional attenuators or isolators are typically required to protect other components inside the instrument).

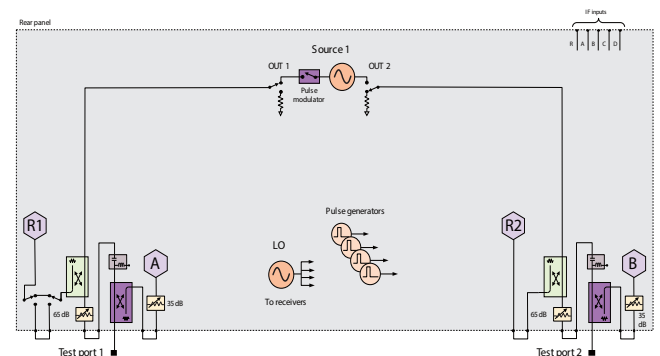

PNA-X Series Test Set and Power Configuration Options¹ (continued)

2-ports, dual sources, with extended power range, combiner, and mechanical switches (Option 222)

Along with the access loops and attenuators of Option 217, Option 222 includes an internal second source, a combiner, mechanical switches, and more access loops. The internal second source provides an additional signal (fixed or swept) for two-tone intermodulation testing of amplifiers, or for use as a local oscillator for testing mixers and frequency converters. The mechanical switches switch the combiner in and out as needed, as well as enabling the additional access loops for advanced configurations. The second source is available through two RF connectors on the front panel, from port 1 when combined with source 1, or via rear-panel access loops. The maximum power rating on the test port couplers is +43 dBm (additional attenuators or isolators are typically required to protect other components inside the instrument). Option 222 is not available on the N5247B. To independently control the frequency of the second internal source, one of the following software applications is required: S93080/029/082/083/084/086/087/089/090x/093/094A.

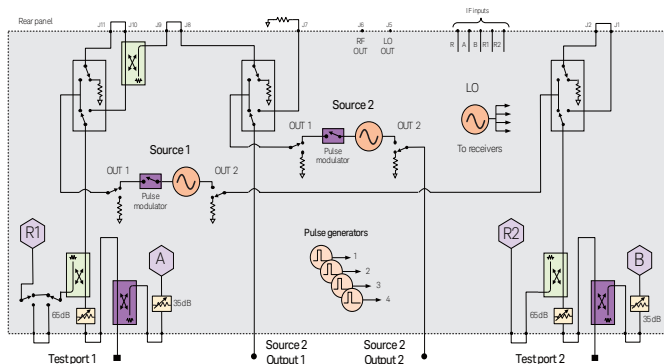

2-ports, dual sources, with extended power range, bias tees, and mechanical switches (Option 224)

Along with the access loops, attenuators, and bias tees of Option 219, Option 224 includes an internal second source, a combiner, mechanical switches, and more access loops. The internal second source provides an additional signal (fixed or swept) for two-tone intermodulation testing of amplifiers, or for use as a local oscillator for testing mixers and frequency converters. The mechanical switches switch the combiner in and out as needed, as well as enabling the additional access loops for advanced configurations. The second source is available through two RF connectors on the front panel, from port 1 when combined with source 1, or via rear-panel (N5241/42/44/45/49B) or front-panel (N5247B) access loops. The bias tees are connected directly to the test port couplers, which limits the maximum power rating on the pair to +30 dBm (additional attenuators or isolators are typically required to protect other components inside the instrument). To independently control the frequency of the second internal source, one of the following software applications is required: S93080/029/082/083/084/086/087/089/090x/093/094A.

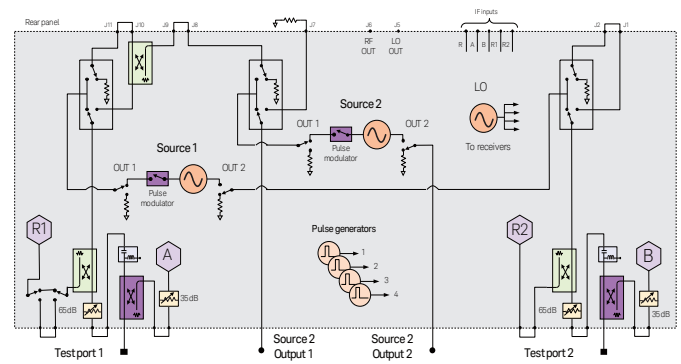

1. The block diagrams shown above include hardware that must be ordered as separate options, such as pulse modulators (Options 021 and 022), and IF access (Option 020), or is controlled by application software, as is the case for the pulse generators. In addition, the combiner type and attenuator values vary by model number. Refer to the product data sheet for the correct block diagram for a specific model.



PNA-X Series Test Set and Power Configuration Options¹ (continued)

4-ports, dual sources, with configurable test set (Option 401)

The standard 4-port test set comes with 12 front-panel access loops and a built-in second source. The loops provide access to the signal path between (a) the source output and the reference receiver, (b) the source output and directional coupler thru arm and (c) the coupled arm of the directional coupler and the port receiver. The internal second source provides an additional signal (fixed or swept) for two-tone intermodulation testing of amplifiers, or for use as a local oscillator when testing mixers and frequency converters. Source 1 is accessible through test ports 1 and 2, and source 2 is accessible through test ports 3 and 4. The standard test set also includes a solid-state internal RF bypass switch in the R1 reference-receiver path. To independently control the frequency of the second internal source, one of the following software applications is required: S93080/029/082/083/084/086/087/089/090x/093/094A.

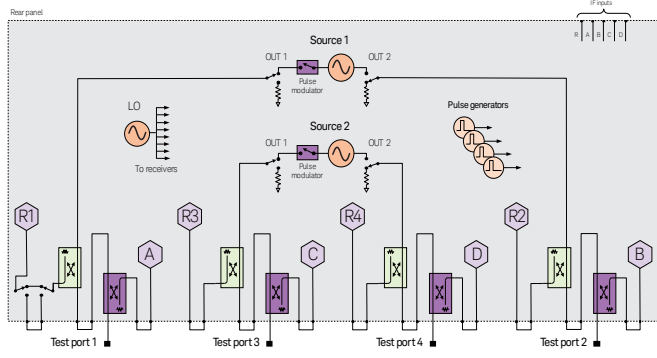

4-ports, dual sources, with extended power range (Option 417)

This configuration comes with two sources, front-panel access loops, and source and receiver attenuators at each port. The source attenuators are settable in 5 dB steps up to 65 dB in N5241/42/49B, and in 10 dB steps up to 60 dB in N5244/45B. The receiver attenuators are settable in 5 dB steps up to 35 dB. The maximum power rating on the test port couplers is +43 dBm (additional attenuators or isolators are typically required to protect other components inside the instrument). Option 417 is not available on the N5247B. To independently control the frequency of the second internal source, one of the following software applications is required: S93080/029/082/083/084/086/087/089/090x/093/094A, and S94510/511A.

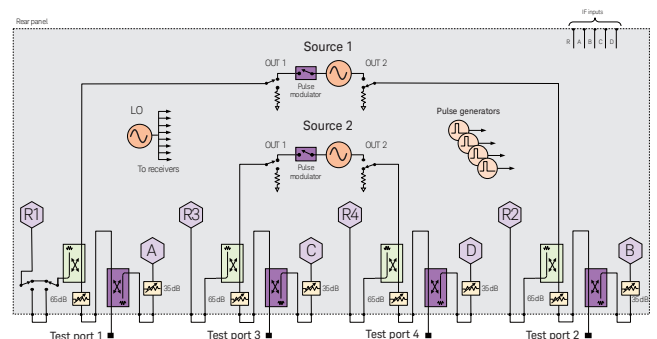

4-ports, dual sources, with extended power range and bias-tees (Option 419)

This configuration comes with two sources, front-panel access loops, and bias tees and source and receiver attenuators at each port. The source attenuators are settable in 5 dB steps up to 65 dB in N5241/42/49B, in 10 dB steps up to 60 dB in N5244/45B, and in 10 dB steps up to 50 dB in N5247B. The receiver attenuators are settable in 5 dB steps up to 35 dB in N5241/42/44/45/49B, and 10 dB steps up to 50 dB in N5247B. The bias tees are connected directly to the test port couplers, which limits the maximum power rating on the pair to +30 dBm (additional attenuators or isolators are typically required to protect other components inside the instrument). To independently control the frequency of the second internal source, one of the following software applications is required: S93080/029/082/083/084/086/087/089/090x/093/094A, and S94510/511A.

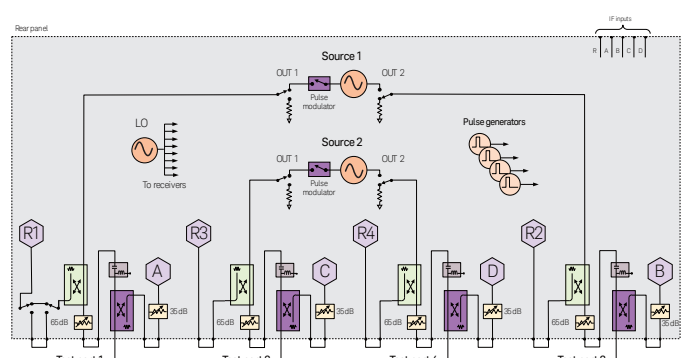

1. The block diagrams shown above include hardware that must be ordered as separate options, such as pulse modulators (Options 021 and 022), and IF access (Option 020), or is controlled by application software, as is the case for the pulse generators. In addition, the combiner type and attenuator values vary by model number. Refer to the product data sheet for the correct block diagram for a specific model.



PNA-X Series Test Set and Power Configuration Options¹ (continued)

4-ports, dual sources, with extended power range, combiner, and mechanical switches (Option 422)

Along with two sources and the access loops and attenuators of Option 417, Option 422 includes a combiner, mechanical switches, and more access loops. The internal second source provides an additional signal (fixed or swept) for two-tone intermodulation testing of amplifiers, or for use as a local oscillator for testing mixers and frequency converters. The mechanical switches switch the combiner in and out as needed, as well as enabling the additional access loops for advanced configurations. The second source drives ports 3 and 4, and is also available from port 1 when combined with source 1, or via rear-panel access loops. The maximum power rating on the test port couplers is +43 dBm (additional attenuators or isolators are typically required to protect other components inside the instrument). Option 422 is not available on the N5247B. To independently control the frequency of the second internal source, one of the following software applications is required: S93080/029/082/083/084/86/087/089/090x/093/094A, and S94510/511A.

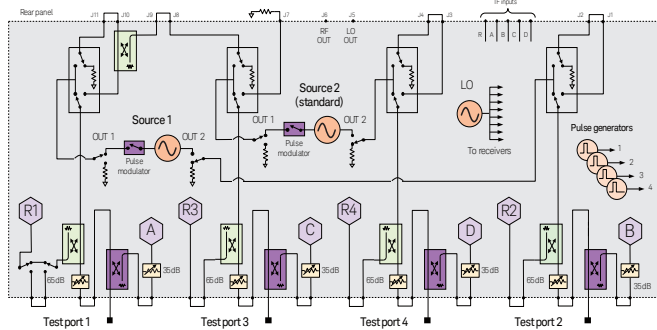

4-ports, dual sources, with extended power range, bias tees, combiner, and mechanical switches (Option 423)

Along with two sources and the access loops, attenuators, and bias tees of Option 419, Option 423 includes a combiner, mechanical switches, and more access loops. The internal second source provides an additional signal (fixed or swept) for two-tone intermodulation testing of amplifiers, or for use as a local oscillator for testing mixers and frequency converters. The mechanical switches switch the combiner in and out as needed, as well as enabling the additional access loops for advanced configurations. The second source drives ports 3 and 4, and is also available from port 1 when combined with source 1, or via rear-panel (N5241/42/44/45/49B) or front-panel (N5247B) access loops. The bias tees are connected directly to the test port couplers, which limits the maximum power rating on the pair to +30 dBm (additional attenuators or isolators are typically required to protect other components inside the instrument). To independently control the frequency of the second internal source, one of the following software applications is required: S93080/029/082/083/084/086/087/089/090x/093/094A, and S94510/511A.

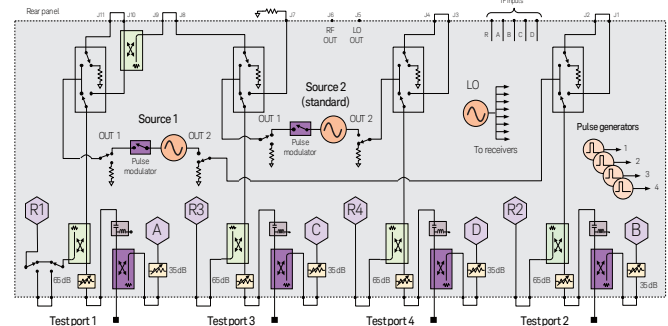

1. The block diagrams shown above include hardware that must be ordered as separate options, such as pulse modulators (Options 021 and 022), and IF access (Option 020), or is controlled by application software, as is the case for the pulse generators. In addition, the combiner type and attenuator values vary by model number. Refer to the product data sheet for the correct block diagram for a specific model.



PNA-X Series Test Set and Power Configuration Options (continued)

4-ports, dual sources, with extended power range, bias tees, combiner, mechanical switches, and low-frequency extension (Option 425)

Along with two sources and the access loops, attenuators, bias tees, combiner, and mechanical switches of Option 423, Option 425 adds additional hardware to extend the start frequency of the PNA-X down to 900 Hz. This test set option is only available for N5242B and N5247B models. For N5242B, Option 425 is available with or without low-noise receiver Option 029. For N5247B, it is only available with Option 029. The extended start frequency is available only for the following measurement classes: standard, gain compression (amplifier and converters), and for magnitude-only measurements using SMC (scalar mixer/converter) or SMC+Phase. In the standard channel, pulsed RF, true-mode stimulus, and source phase control are not supported for measurements below 10 MHz. To independently control the frequency of the second internal source, one of the following software applications is required: S93080/029/082/083/084/086/087/089/090x/093/094A, and S94510/511A. The block diagram below shows how the low-frequency hardware is configured for one test port; the other test ports are configured similarly. For test port 1, the combiner and noise tuner (not shown) are only available for use down to 10 MHz, and for test port 2, the low-noise receiver (not shown) is only available for use down to 10 MHz.

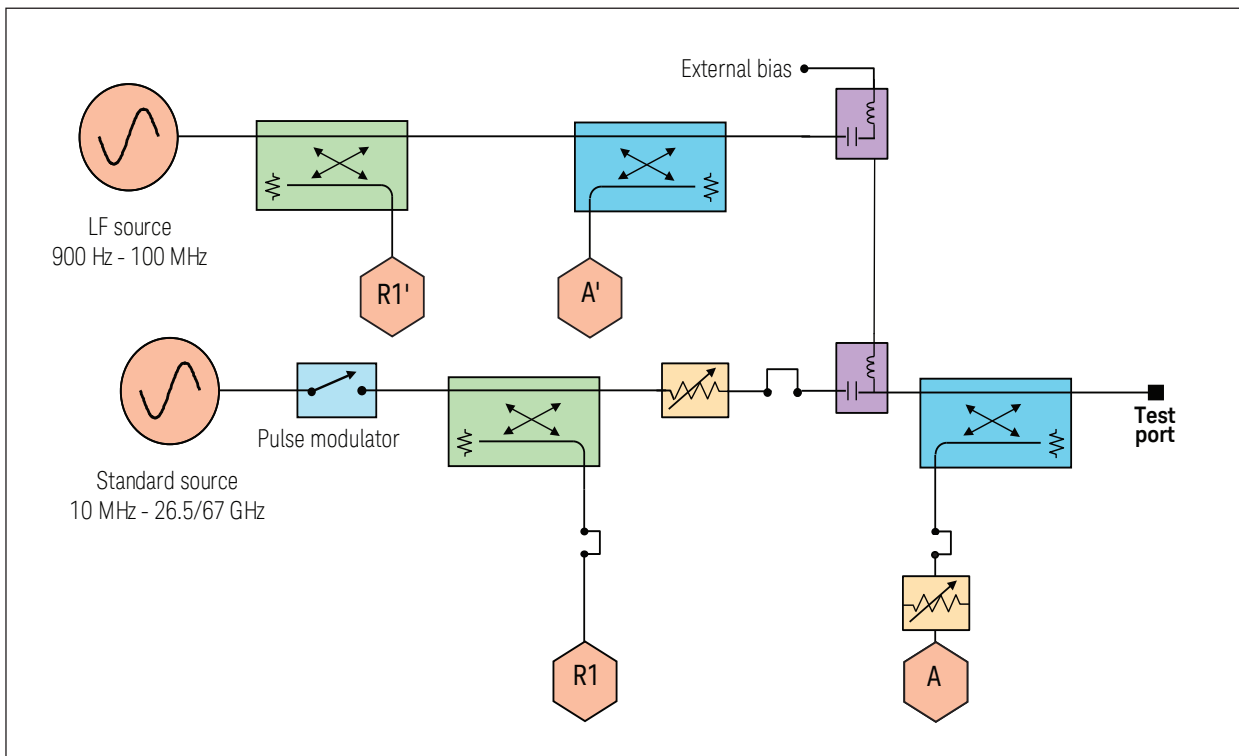

PNA Series Test Set and Power Configuration Options¹

The PNA is an integrated vector network analyzer featuring a built-in S-parameter test set, one or two synthesized sources used for device stimulus, a solid-state drive, USB interfaces, and a 12.1" LCD touch screen display. The N5221B and the N5222B have 50 ohm, ruggedized 3.5 mm (m) test ports. The N5224B and the N5225B have 50 ohm, ruggedized 2.4 mm (m) test ports. The N5227B has 50 ohm, ruggedized 1.85 mm (m) test ports. Included with each instrument is a mouse, keyboard (U.S. style), a 3-year return-to-Keysight service warranty, and one day of on-site productivity assistance (PS-S20-PNA).

A test set and power configuration option is mandatory. Choose one of the following:

2-ports, single source, base configuration (Option 200/210)

The 2-port with base configuration has no front-panel access loops.

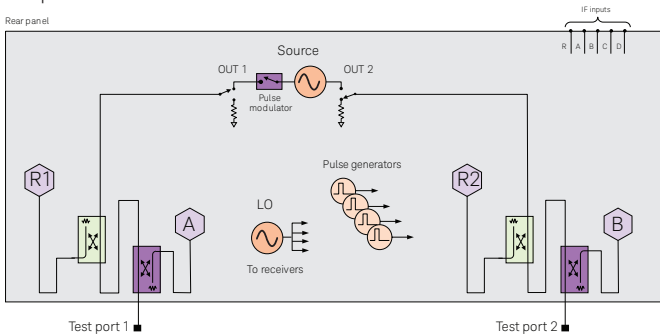

2-ports, single source, with configurable test set (Option 201)

The 2-port configurable test set comes with six front-panel access loops. The loops provide access to the signal path between (a) the source output and the reference receiver, (b) the source output and directional coupler thru arm and (c) the coupled arm of the directional coupler and the port receiver at all ports. Also included is a solid-state internal RF bypass switch in the R1 reference-receiver path.

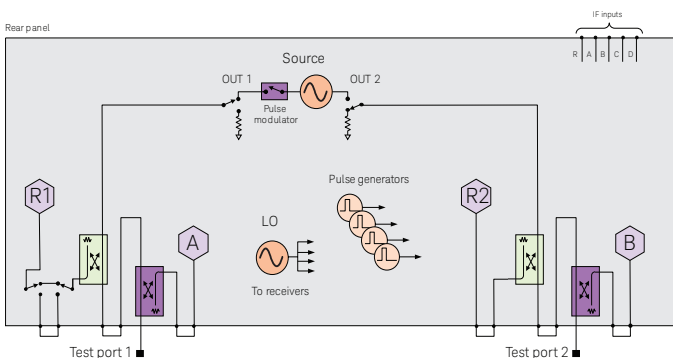

2-ports, single source, with configurable test set, bias tees, and low-frequency extension (Option 205)

Along with the front-panel loops and R1 reference-receiver switch of Option 201, Option 205 adds bias tees and additional hardware to extend the start frequency of the PNA down to 900 Hz. This test set option is only available for N5222B and N5227B models. The extended start frequency is available only for the following measurement classes: standard, gain compression (amplifier and converters), and for magnitude-only measurements using SMC (scalar mixer/converter) or SMC+Phase. In the standard channel, pulsed RF, true-mode stimulus, and source phase control are not supported for measurements below 10 MHz. The block diagram below shows how the low-frequency hardware is configured for one test port; the other test ports are configured similarly.

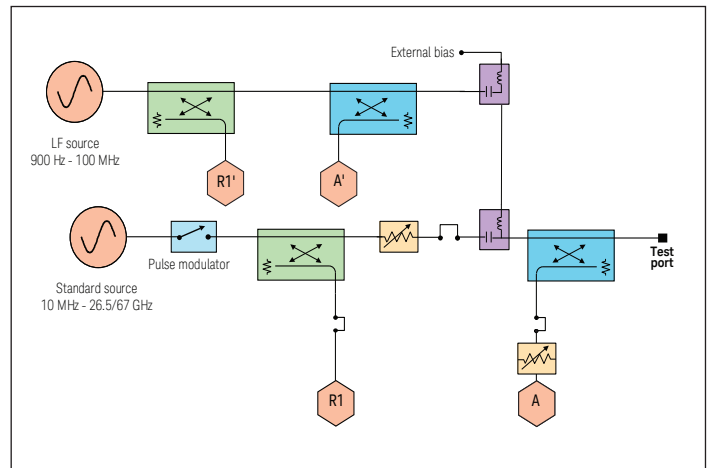

1. The block diagrams shown above include hardware that must be ordered as separate options, such as pulse modulators (Option 021), and IF access (Option 020), or is controlled by application software, as is the case for the pulse generators. In addition, the combiner type and attenuator values vary by model number. Refer to the product data sheet for the correct block diagram for a specific model.



PNA Series Test Set and Power Configuration Options¹ (continued)

2-ports, single source, with extended power range (Option 217)

This configuration comes with front-panel access loops, and source and receiver attenuators at each port. The source attenuators are settable in 5 dB steps up to 65 dB in N5221/22B, and in 10 dB steps up to 60 dB in N5224/25B. The receiver attenuators are settable in 5 dB steps up to 35 dB. The maximum power rating on the test port couplers is +43 dBm (additional attenuators or isolators are typically required to protect other components inside the instrument). Option 217 is not available on the N5227B.

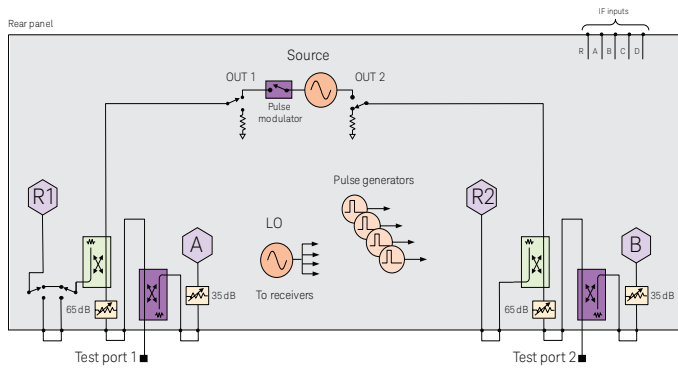

2-ports, single source, with extended power range and bias-tees (Option 219)

This configuration comes with front-panel access loops, and bias tees and source and receiver attenuators at each port. The source attenuators are settable in 5 dB steps up to 65 dB in N5221/22B, in 10 dB steps up to 60 dB in N5224/25B, and in 10 dB steps up to 50 dB in N5227B. The receiver attenuators are settable in 5 dB steps up to 35 dB in N5221/22/24/25B, and 10 dB steps up to 50 dB in N5227B. The bias tees are connected directly to the test port couplers, which limits the maximum power rating on the pair to +30 dBm (additional attenuators or isolators are typically required to protect other components inside the instrument).

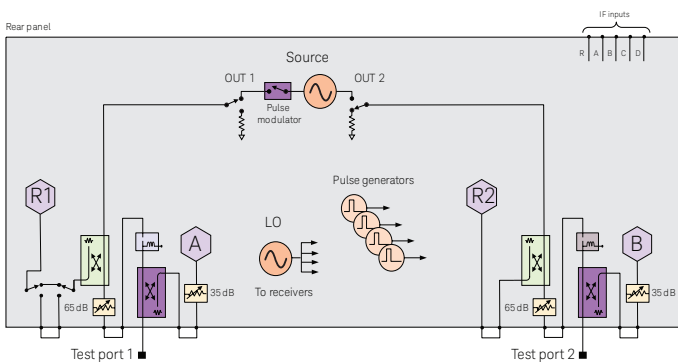

4-ports, dual source, base configuration (Option 400/410)

The 4-port with base configuration has no front-panel access loops. To independently control the frequency of the second internal source, one of the following software applications is required: S93080/029/082/083/084/086/087/089/090x/093/094A.

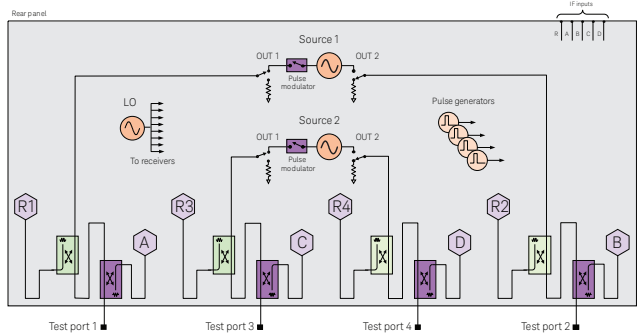

4-ports, dual source, with configurable test set (Option 401)

The 4-port configurable test set comes with two internal sources and twelve front-panel access loops. The loops provide access to the signal path between (a) the source output and the reference receiver, (b) the source output and directional coupler thru arm and (c) the coupled arm of the directional coupler and the port receiver at all ports. Also included is a solid-state internal RF bypass switch in the R1 reference-receiver path. To independently control the frequency of the second internal source, one of the following software applications is required: S93080/029/082/083/084/086/087/089/090x/093/094A.

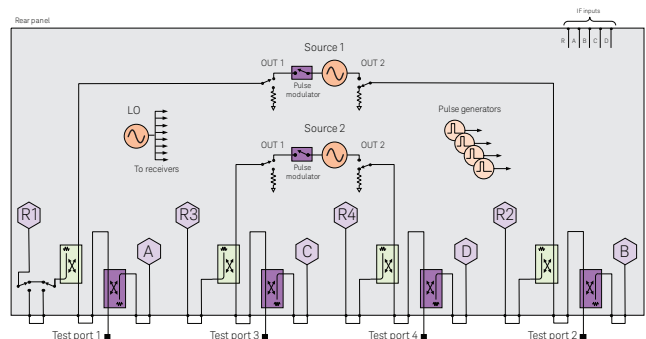

1. The block diagrams shown above include hardware that must be ordered as separate options, such as pulse modulators (Options 021 and 022), and IF access (Option 020), or is controlled by application software, as is the case for the pulse generators. In addition, the combiner type and attenuator values vary by model number. Refer to the product data sheet for the correct block diagram for a specific model.



PNA Series Test Set and Power Configuration Options¹ (continued)

4-ports, dual source, with extended power range (Option 417)

This configuration comes with two sources, front-panel access loops, and source and receiver attenuators at each port. The source attenuators are settable in 5 dB steps up to 65 dB in N5221/22B, and in 10 dB steps up to 60 dB in N5224/25B. The receiver attenuators are settable in 5 dB steps up to 35 dB. The maximum power rating on the test port couplers is +43 dBm (additional attenuators or isolators are typically required to protect other components inside the instrument). Option 417 is not available on the N5227B. To independently control the frequency of the second internal source, one of the following software applications is required: S93080/029/082/083/084/086/087/089/090x/093/094A.

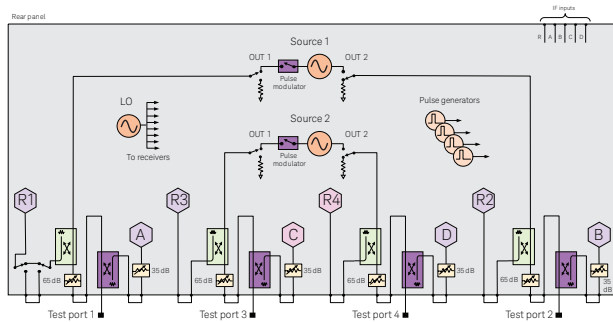

4-ports, dual source, with extended power range and bias-tees (Option 419)

This configuration comes with two sources, front-panel access loops, and bias tees and source and receiver attenuators at each port. The source attenuators are settable in 5 dB steps up to 65 dB in N5221/22B, in 10 dB steps up to 60 dB in N5224/25B, and in 10 dB steps up to 50 dB in N5227B. The receiver attenuators are settable in 5 dB steps up to 35 dB in N5221/22/24/25B, and 10 dB steps up to 50 dB in N5227B. The bias tees are connected directly to the test port couplers, which limits the maximum power rating on the pair to +30 dBm (additional attenuators or isolators are typically required to protect other components inside the instrument). To independently control the frequency of the second internal source, one of the following software applications is required: S93080/029/082/083/084/086/087/089/090x/093/094A.

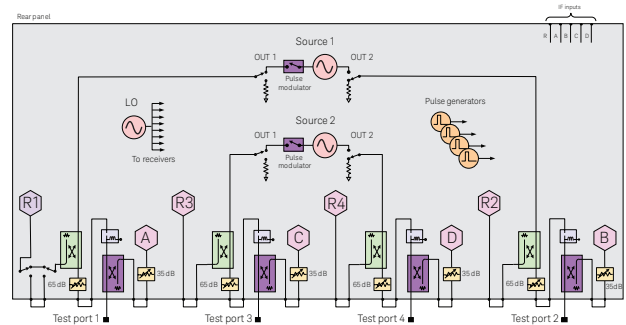

1. The block diagrams shown above include hardware that must be ordered as separate options, such as pulse modulators (Options 021 and 022), and IF access (Option 020), or is controlled by application software, as is the case for the pulse generators. In addition, the combiner type and attenuator values vary by model number. Refer to the product data sheet for the correct block diagram for a specific model.



PNA-L Series Test Set and Power Configuration Options

The PNA-L is an integrated vector network analyzer featuring a built-in S-parameter test set, one synthesized source used for device stimulus, a solid state drive, USB interfaces, and a 12.1" LCD touch screen display. The N5239B, N5231B and the N5232B have 50 ohm, ruggedized 3.5 mm (m) test ports. The N5234A and N5235B have 50 ohm, ruggedized 2.4 mm (m) test port. Included with each instrument is a mouse, keyboard (U.S. style), and a 3-year return-to-Keysight service warranty. For one day of on-site productivity assistance (not included with instrument purchase), request quantity 1 each PS-S20-PNA.

A test set and power configuration option is mandatory. Choose one of the following:

2 ports, single source, base configuration (Option 200)

The 2-port with base configuration has no front-panel access loops.

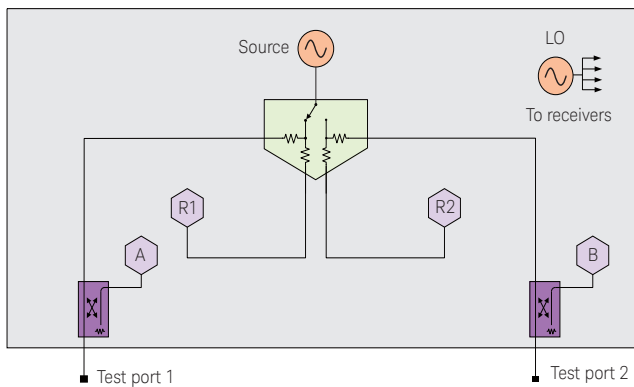

2 ports, single source, with configurable test set and source attenuators (Option 216)

The 2-port test set comes with a configurable test set and source attenuator at each port. The configurable test set adds six front-panel access loops. The loops provide access to the signal path between (a) the source output and the reference receiver, (b) the source output and directional coupler thru arm, and (c) the coupled arm of the directional coupler and the port receiver at all ports. The source attenuators are settable in 10 dB steps up to 60 dB.

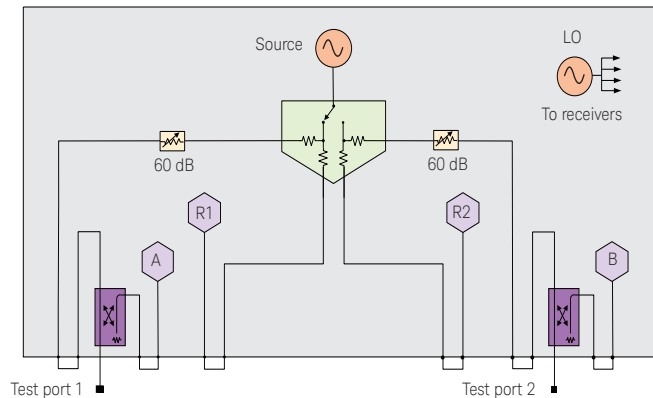

4 ports, single source, base configuration (Option 400)

The 4-port base configuration has no front-panel loops, and is available only on the N5231B and N5232B.

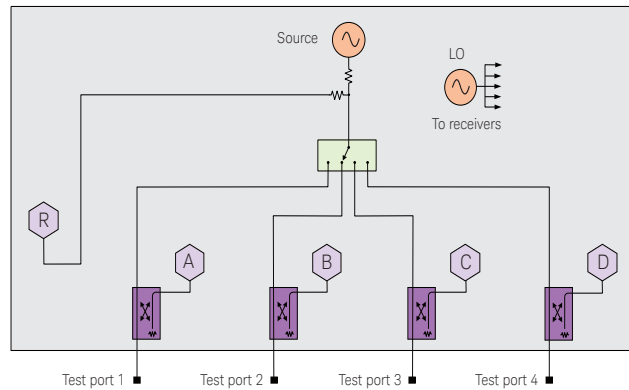

4 ports, single source, with configurable test set and source attenuator (Option 416)

The 4-port test set comes with a configurable test set and one source attenuator to be shared with all ports. The configurable test set adds nine front-panel access loops. The loops provide access to the signal path between (a) the source output and the reference receiver, (b) the source output and directional coupler thru arm at all ports, and (c) the coupled arm of the directional coupler and the port receiver at all ports. The source attenuator is settable in 10 dB steps up to 60 dB. This configuration is available only on the N5231B and N5232B.

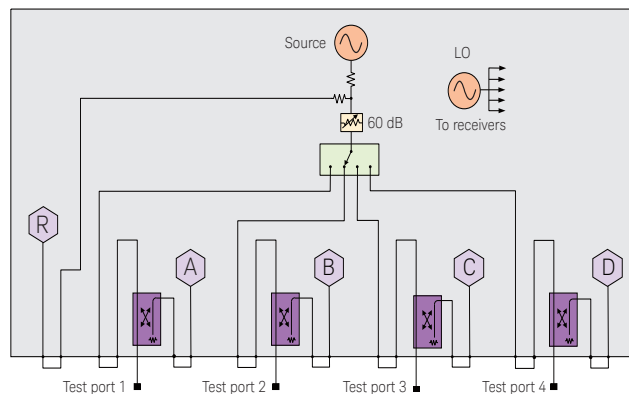

PNA Family Applications and Options

Measurement application software

Solid black series name indicates the feature is available on that series, while gray series name with strikethrough indicates the feature is not available on that series. For example:

PNA: Available on PNA Series

~~PNA~~: Not available on PNA Series

Automatic fixture removal (S93007A)

PNA-X PNA PNA-L

Many devices do not have coaxial connectors and are put in fixtures in order to measure them in a coaxial environment. Accurately removing the effects of the fixture is required to get a good measurement of the device under test (DUT). This application adds a powerful application wizard to guide you through characterizing a fixture and removing it from the measurement. Devices can be single ended or differential. Files can be saved in a variety of formats for later use in PNA, ADS, and PLTS.

Time domain analysis (S93010A)

PNA-X PNA PNA-L

This application enables the analyzer to view reflection and transmission responses in time or distance. Use time domain to tune filters, gate out the response of fixtures and cables, characterize the impedance of transmission lines and more. If eye-diagram analysis, W-element modeling or high-speed interconnect testing is required, PLTS N1930B software must be used.

Dynamic uncertainty for S-parameter measurements (S93015A)

PNA-X PNA PNA-L

This enables the analyzer to display the measurement uncertainty dynamically (real-time) on the same screen as the measurement trace and get more reliable uncertainty estimation. Uncertainty of a calibration standard, noise in measurements, cable, and connector repeatability are included and this function is compatible with the current Keysight Uncertainty Calculator.

Frequency offset measurements (S93080A)

PNA-X PNA PNA-L

This application enables the analyzer to set the frequency of the internal sources independently from where the receivers are tuned, and is required to configure an external source using External Device Configuration. This ability is important for measuring amplifiers, mixers, and frequency converters. The functionality provided by S93080A is also included with S93029/082/083/084/086/087/089/090x/093/094A, and S94510/511A.

Scalar mixer/converter measurements (S93082A)

PNA-X PNA PNA-L

With a simple setup and calibration, this application delivers the highest accuracy for scalar conversion-loss/gain measurements by combining one-port and power-meter calibrations to remove mismatch errors. S93082A provides an intuitive and easy-to-use user interface for setting up mixer and converter measurements, with single or dual conversion stages. It can control the analyzer's built-in source(s) as well as external signal generators for use as LO signals. Supported external sources include the Keysight ESG, PSG, EXG, and MXG Series, as well as other SCPI-controlled signal generators. S93082A is a subset of S93083A, so they should not be installed together. S93082A is compatible with S93084A, which enables measurements of converters with internal LOs.

Vector and scalar mixer/converter measurements (S93083A)

PNA-X PNA ~~PNA-L~~

This application includes the scalar mixer/converter plus phase (SMC+Phase) measurement class that provides fully calibrated conversion gain/loss, relative phase, and absolute group delay measurements of mixers and converters without the need for reference or calibration mixers. Eliminating the calibration mixer requires a U9391C/F/G comb generator¹ and an external DC power supply capable of sourcing +15 V and 300 mA for U9391C/F or 800 mA for U9391G. A vector mixer/converter measurement (VMC) class is also included for measuring the phase difference between multiple paths or devices, or for measuring phase shifts within a device. Using VMC or the comb-generator-based calibration for SMC+Phase requires an instrument with a configurable test set (i.e., has front-panel RF loops). For units without front-panel loops, SMC+Phase can be used with a calibration mixer supplied by the user. S93083A provides an intuitive and easy-to-use user interface for setting up mixer and converter measurements, with single or dual conversion stages. It can control the analyzer's built-in source(s) as well as external signal generators for use as LO signals. Supported external sources include the Keysight ESG, PSG, EXG, and MXG Series, as well as other SCPI-controlled signal generators. S93083A is a superset of S93082A, so they should not be installed together. S93083A is compatible with S93084A, which enables measurements of converters with internal LOs.

1. When a comb generator is used as a phase reference for calibration and the start frequency of the measurement is less than 55 MHz, a user-supplied calibration mixer is required. For measurements between 50 GHz and 67 GHz, an additional high-pass filter is required (two back-to-back Keysight V281A waveguide-to-coax adapters recommended; must be ordered separately).



PNA Family Applications and Options (continued)

Embedded LO capability (S93084A)

PNA-X PNA ~~PNA-L~~

This application tunes the analyzer's receivers to the output frequency of the converter under test without the need for access to internal LOs or a common reference signal. S93084A is intended to work with S93029/082/083/086/087A measurement applications.

Gain compression measurements (S93086A)

PNA-X PNA ~~PNA-L~~

The gain compression application (GCA) provides input power, output power, gain, and phase at the compression point of an amplifier or frequency converter, over a specified frequency range. GCA's SMART Sweep is very fast and easy-to-use. GCA also includes a guided calibration that corrects for absolute power levels, frequency response, and mismatch errors.

Intermodulation distortion measurements (S93087A)

PNA-X PNA ~~PNA-L~~

The intermodulation distortion (IMD) application makes it very easy to set up and calibrate swept-IMD measurements of both amplifiers and frequency converters. It controls the frequency and power of internal and external sources and tunes the receivers to the main tones as well as the IMD products in a single measurement channel. The user can sweep either the center frequency of the two stimulus signals, the frequency spacing of the two stimulus signals about a fixed center frequency, or the power of one or both stimulus signals or the power of the LO signal. The analyzer can measure intermodulation distortion products of order 2, 3, 5, 7, or 9, and can display the associated intercept points. In addition, an IM Spectrum mode gives a spectrum-analyzer-like display for confirming or trouble-shooting measurements. Not available with PNA Options 200, 210, 400 and 410. When configured with a 2-port PNA or 2-port PNA-X with either Option 201, 217, or 219, an external signal generator and a combiner are required. When configured with a 4-port PNA or 4-port PNA-X with Option 401, 417, or 419, the two internal sources and an unused test port coupler configured as a combiner can be used for two-tone IMD measurements. When configured with PNA-X Option 22x or 42x, the two internal sources and internal combiner can be used for two-tone IMD measurements.

Source phase control (S93088A)

PNA-X PNA ~~PNA-L~~

This application allows users to set calibrated, arbitrary phase differences between two signal sources. The sources can be the analyzer's internal sources or external signal generators routed through the analyzer's test set. The phase difference can be fixed, or swept between two specified phase values. Option 088 also controls the relative power level between the sources using the receiver-leveling feature. Option 088 is targeted for active-load control, where the analyzer provides a precise, electronically settable impedance to the output port of a device, while gain and output power are measured. This capability can be combined with external load-pull software to create traditional load-pull power contours. Not available with PNA Options 200 and 210.

Differential and I/Q device measurements (S93089A)

PNA-X PNA ~~PNA-L~~

This application combines source-phase control of multiple internal or external sources with frequency-offset mode, enabling simplified test of I/Q modulators/converters and differential mixers, and harmonic measurements of differential amplifiers. The phase difference between sources can be fixed (for example, at 90 or 180 degrees), or swept between two specified phase values. Providing accurate control of the relative phase between sources eliminates the need for hybrid couplers and baluns to create quadrature or differential signals. After achieving the desired phase alignment, the instrument's receivers can be tuned to all frequencies needed to characterize the DUT. On an I/Q modulator for example, measurements can be made of both the desired and suppressed conversion bands, along with LO leakage, harmonics and other spurious signals. Phase sweeps can be used to determine a DUT's phase imbalance versus frequency. Users can specify measurements with individual receivers or multiple receivers combined with a wide range of mathematical operators. Power measurements can employ match correction for increased accuracy. S93089A only works on 4-port PNA or PNA-X models.



PNA Family Applications and Options (continued)

Measurement application software (continued)

Solid black series name indicates the feature is available on that series, while gray series name with strikethrough indicates the feature is not available on that series. For example:

PNA: Available on PNA Series
~~PNA~~: Not available on PNA Series

Spectrum analysis (S93090xA)

PNA-X PNA ~~PNA-L~~

The spectrum analyzer (SA) application adds high-performance microwave spectrum analysis to PNA-X, PNA, and PNA-L Series network analyzers. With fast stepped-FFT sweeps resulting from optimized data processing, the SA application provides quick spurious searches over broad frequency ranges. Simultaneous spectrum measurements can be done using up to five test and reference receivers. This multi-channel SA can be used with the internal swept-signal generators for efficient measurements of spurious signals emanating from mixers and frequency converters. The SA application employs source-power and receiver-response calibration as well as fixture de-embedding, providing in-fixture and on-wafer spectrum measurements with the highest level of accuracy. It is recommended to use this option with PNA or PNA-X instruments with internal receiver attenuators to avoid receiver compression when measuring large signals. For use with PNA-L models, test set option 216 or 416 is recommended so that external attenuators can be connected via the front-panel jumpers to avoid receiver compression. The upper frequency range of the SA application is determined by the installed SA license or the stop frequency of the instrument, whichever is smaller. There are several frequency choices intended for standalone instruments: S930900A to 8.5 GHz, S930901A to 13.5 GHz, S930902A to 26.5 GHz, S930904A to 43.5 GHz, S930905A to 50 GHz, and S930907A to 67 GHz. Intended for use with analyzers configured with broadband or banded millimeter-wave extenders, several more choices are available: S930909A to 90 GHz, S93093A to 120 GHz, and S93094A for frequencies above 120 GHz.

Spectrum analysis, up to 120 GHz (S93093A)

PNA-X PNA ~~PNA-L~~

S93093A has all of the capability of the S93090xA spectrum analyzer application, with an upper frequency of 120 GHz. It is intended for analyzers configured with broadband or banded millimeter-wave frequency extenders, using a millimeter-wave controller. With this configuration, the analyzer's internal receiver attenuators are not in the receiver paths, so they cannot be used to reduce signal levels. External attenuators may be required to avoid compressing the receivers in the millimeter-wave frequency extenders. When using S93093A for millimeter-wave spectrum analysis, an N5261/62A or an N5292A millimeter-wave controller is required. When S93093A is installed on a standalone network analyzer, it will provide spectrum analysis up to the frequency limit of the instrument.

Spectrum analysis, beyond 120 GHz (S93094A)

PNA-X PNA ~~PNA-L~~

S93094A has all of the capability of the S93090xA spectrum analyzer application, with an upper frequency limit determined solely by the broadband or banded millimeter-wave frequency extenders used in the system. With this configuration, the analyzer's internal receiver attenuators are not in the receiver paths, so they cannot be used to reduce signal levels. External attenuators may be required to avoid compressing the receivers in the millimeter-wave frequency extenders. When using S93094A for millimeter-wave spectrum analysis, an N5261/62A or an N5292A millimeter-wave controller is required. When S93094A is installed on a standalone network analyzer, it will provide spectrum analysis up to the frequency limit of the instrument.

True-mode stimulus (S93460A)

PNA-X PNA ~~PNA-L~~

S93460A provides mismatch-corrected true-mode (true differential mode and true common mode) stimulus and enables accurate balanced measurements under real operating conditions. It also provides balanced measurements with forward-only sweeps, reverse-only sweeps, and frequency or power sweeps with arbitrary phase and amplitude offsets. S93460A only works on 4-port PNA or PNA-X models.

N-port measurements (S93551A)¹

PNA-X PNA ~~PNA-L~~

S93551A adds a multiport analyzer mode, which enables full N-port error correction and measurement capabilities using an external test set. Only the standard measurement class is available in the multiport analyzer mode. Not available with PNA Options 200, 210, 400 and 410. For multiport analysis greater than 8 ports, it is highly recommended to use N1930B PLTS software to manage the large data files that grow exponentially (12 port S-parameter files have 144 S-parameter elements).

1. When configuring N524xB as a multiport analyzer using S93551A and a multiport test set, the combiner feature of Option 22x or 42x is temporarily disabled. When configured as a standalone analyzer, the combiner feature is enabled. When ordering a test set, select an appropriate interface kit. Refer to page 28 Multiport Measurements section for more details.



PNA Family Applications and Options (continued)

Noise figure options and applications

Add low-noise receiver (Option 029)

PNA-X ~~PNA~~ ~~PNA-L~~

This option adds a low-noise receiver to the PNA-X to provide wideband noise figure and noise-power measurements on a broad range of devices. The noise receiver has three gain settings, and contains the necessary filters to eliminate out-of-band noise conversion. For N5241/42/49B instruments, Option 029 adds a mechanical switch at port one to allow use of an external ECal module as an impedance tuner to provide high-accuracy noise figure measurements. For N5244/45/47B instruments, Option 029 adds a built-in impedance tuner at port one with a bypass switch. The noise receiver start frequency is 10 MHz and for N5241/42/44/45/49B instruments, it works up to the stop frequency of the instrument. For N5247B instruments, the low-noise receiver and tuner work up to 50 GHz only. For noise figure measurements between 50 and 67 GHz, any of the standard network analyzer receivers can be used. Option 029 is intended for use with S93029A software. Without the software, the noise hardware cannot be utilized.

Noise figure measurements with vector correction (S93029A)

PNA-X PNA ~~PNA-L~~

This software application enables high-accuracy noise figure and noise-power measurements of amplifiers, frequency converters, and mixers, utilizing Keysight's unique vector-source-correction technique that uses a source-impedance tuner to remove the effects of imperfect system-source match. This approach yields accuracy that surpasses that provided by the Y-factor method and other cold-source implementations, especially for in-fixture, on-wafer, and automated-test environments. A scalar-calibrated method is also available that offers less accuracy, but is faster and does not require an impedance tuner.

If S93029A is used on a PNA-X configured with Option 029, then it makes full use of the built-in low-noise receiver. Optionally, noise figure measurements can be made using the standard receivers for high-gain (> 60 dB), narrowband devices that might otherwise overload the low-noise receiver, or for noise figure measurements between 50 and 67 GHz on the N5247B. If running on a PNA, a PNA-X without Option 029, or for measurements up to 67 GHz, then the instrument's standard receivers are used. For those cases, an external preamplifier and filter(s) is required for devices with < 30 dB of excess noise (gain plus noise figure in dB) up to 20 GHz, < 40 dB up to 50 GHz, or < 45 dB up to 67 GHz. Instruments with front panel jumpers are recommended as they provide a convenient spot for adding a preamplifier and filter for low-gain, low-noise-figure devices. S93029A controls Keysight N4690¹ Series ECal modules

configured as impedance tuners for use with N522xB PNA models or N5241/42/49B PNA-X models, or a built-in tuner for N5244/45/47B PNA-X models with Option 029.

For calibration, a standard mechanical cal kit or ECal module is required for the S-parameter portion of the cal (an ECal used as a tuner cannot be shared for calibration). To calibrate the low-noise receiver, either a noise source (346C or 346C-K01 recommended) or power meter is required. To calibrate a standard receiver for noise figure measurements, a power meter is required. For measurements of mixers and converters, a power meter is always required, independent of whether a noise source or power meter is used to calibrate the noise receiver. All calibration accessories must be ordered separately.

1. 85090 or N4430 Series ECal modules are not supported



PNA Family Applications and Options (continued)

PNA-X block diagrams with noise figure option

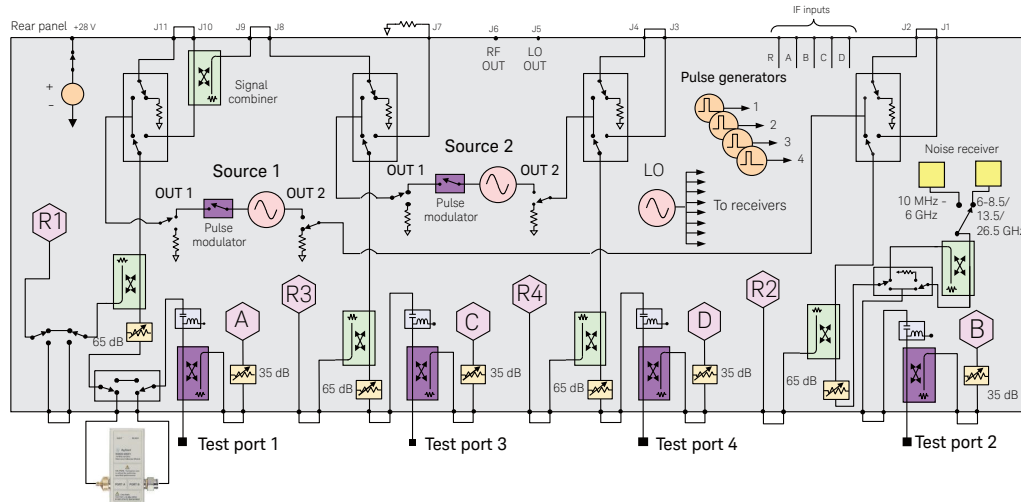

N5241/42/49B 4-port block diagram with noise figure option¹

Impedance tuner for noise figure measurements

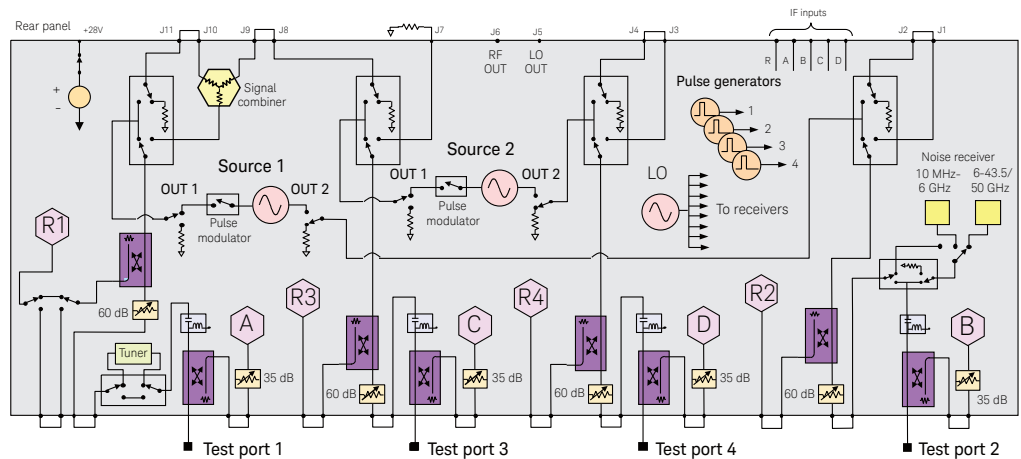

N5244/45B 4-port block diagram with noise figure option¹

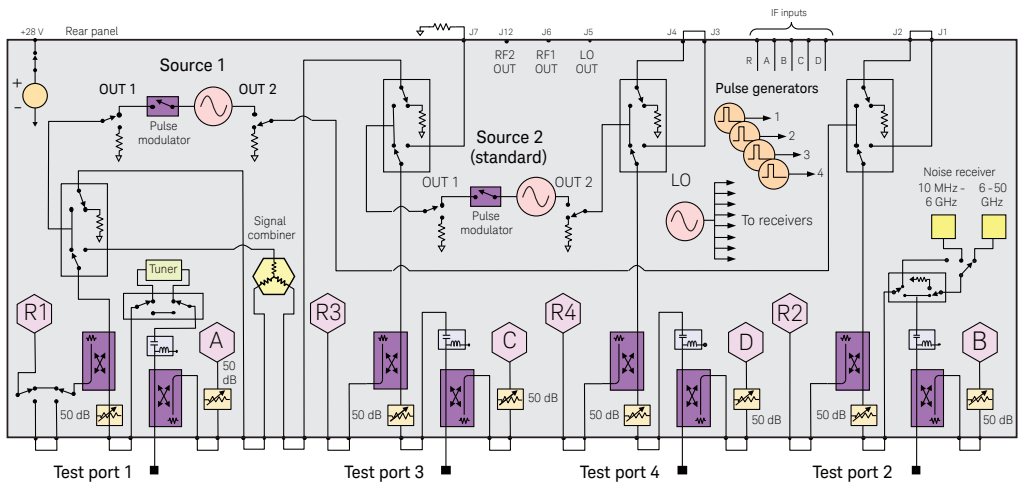

N5247B 4-port block diagram with noise figure option¹

1. S93029A software is required to control the impedance tuner and tuner switch at port one, and the noise receiver and noise switch at port two



PNA Family Applications and Options (continued)

Noise figure measurement summary

Overview	S93029A without Option 029	S93029A with Option 029
Description	Noise figure application using standard receivers only, for all PNA/PNA-X models.	Noise figure application using standard or low-noise receivers, for all PNA-X models.
Required options	Not recommended with PNA Options 200, 210, 400, 410.	For N5241/42/49B, one of Options 21x, 22x, 41x or 42x. For N5244/45/47B, one of Options 22x or 42x.
Includes low-noise receiver	No	Yes ¹
Includes filters for LO-harmonic rejection	No	Yes ¹
Includes source tuner bypass switch	No	Yes
Use standard receivers for noise figure measurements ²	Yes	Yes
Vector noise calibration available using ECal as tuner	Yes	Yes
Vector noise calibration using built-in tuner	No	Yes, for N5244/45/47B ¹
Recommended ECal for vector noise calibration ³	3.5 mm N4691B-MOF (N5221/22/41/42/49B) 2.4 mm N4693A-MOF (N5224/25/44/45B) 1.85 mm N4694A-MOF (N5227/47B)	3.5 mm N4691B-MOF (N5241/42/49B) Built-in for N5244/45/47B
Included tuner accessories for m-f ECal	3.5 mm N5242-20137 cable, 85052-60013 m-f adapter (N5221/22/41/42/49B) 2.4 mm N5245-20140 cable, 85056-60007 m-f adapter (N5224/25/44/45B) 1.85 mm N5247-20142 cable, 85058-60115 m-f adapter (N5227/47B)	3.5 mm N5242-20137 cable, 85052-60013 m-f adapter (N5241/42/49B) N/A for N5244/45B, due to built-in tuner 1.85 mm N5247-20142 cable, 85058-60115 m-f adapter (N5247B, for use with external 67 GHz ECal)
Recommended adapter for f-f ECal tuner (N4691B/93A/94A-00F)	3.5 mm 85052-60014 m-m adapter (N5221/22/41/42/49B) 2.4 mm 85056-60005 m-m adapter (N5224/25/44/45B) 1.85 mm 85058-60113 m-m adapter (N5227/47B)	3.5 mm 85052-60014 m-m adapter (N5241/42/49B) N/A for N5244/45/47B, due to built-in tuner
Scalar noise calibration available	Yes	Yes
S-parameter, conversion gain/loss measurements		
Max freq (GHz)	8.5/13.5/26.5/43.5/50/67	8.5/13.5/26.5/43.5/50/67
NF measurements, amplifiers		
Max frequency, using low-noise receivers (GHz)	N/A	8.5/13.5/26.5/43.5/50
Max frequency, using standard receivers (GHz) ²	8.5/13.5/26.5/43.5/50/67	8.5/13.5/26.5/43.5/50
Calibration accessories for low-noise receivers	N/A	Cal kit or ECal, 346C or 346C-K01 noise source or power meter
Calibration accessories for standard receivers	Cal kit or ECal, power meter	Cal kit or ECal, power meter
NF measurements, converters		
Max DUT input frequency (GHz)	8.5/13.5/26.5/43.5/50/67	8.5/13.5/26.5/43.5/50/67
Max DUT output frequency, using low-noise receivers (GHz)	N/A	8.5/13.5/26.5/43.5/50
Max DUT output frequency, using standard receivers (GHz) ²	8.5/13.5/26.5/43.5/50/67	8.5/13.5/26.5/43.5/50/67
Calibration accessories for low-noise receivers	N/A	Cal kit or ECal, power meter, 346C or 346C-K01 noise source (optional)
Calibration accessories for standard receivers	Cal kit or ECal, power meter	Cal kit or ECal, power meter

1. For N5247B, the low-noise receiver and tuner works up to 50 GHz only.

2. External preamplifier and filter(s) required if DUT excess noise (gain plus noise figure) is < 30 dB up to 20 GHz, < 40 dB up to 50 GHz, or < 45 dB up to 67 GHz.

3. Only N4690 Series ECal modules are supported for use as an impedance tuner.



PNA Family Applications and Options (continued)

Pulse, antenna, mm-wave applications and options

Solid black series name indicates the feature is available on that series, while gray series name with strikethrough indicates the feature is not available on that series. For example:

PNA: Available on PNA Series
~~PNA~~: Not available on PNA Series

Basic pulsed-RF measurements (S93025A)

PNA-X PNA ~~PNA~~

This application enables four internal pulse generators that can be used to control the internal pulse modulators (Options 021 and 022), and it provides an integrated pulse application that uses the wideband-detection method. The pulse application provides an easy way to set up point-in-pulse measurements with pulse width as narrow as 200 ns, and pulse-profile measurements with 50 ns minimum timing resolution. Using the built-in pulse modulators, the PNA and PNA-X are complete pulsed-RF measurement solutions, eliminating the need for external test sets and pulse generators. S93025A also controls external pulse generators and modulators, and can synchronize to external master pulses. Option 021 is recommended for forward-only pulsed-RF measurements, and Options 021 and 022 are recommended for bi-directional pulsed-RF measurements. The N1966A Pulse I/O adapter is recommended if using external master pulses or external pulse modulators.

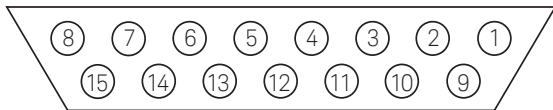

Pulse I/O D-sub connector (DB-15 female)

Advanced pulsed-RF measurements (S93026A)

PNA-X PNA ~~PNA~~

This application includes all of the capability of S93025A (including enabling the four internal pulse generators), and adds the narrowband-pulse-detection method to extend pulse measurement capability to 20 ns pulse widths for point-in-pulse measurements, and 10 ns timing resolution for pulse-profile measurements. With narrowband-detection mode, S93026A sets the coefficient of the analyzer's digital-IF filters to null out unwanted spectral components, enables the receiver IF gates, and performs optimization for measurement sensitivity. Using the built-in pulse modulators, the PNA and PNA-X are complete pulsed-RF measurement solutions, eliminating the need for external test sets and pulse generators. S93026A also controls external pulse generators and modulators, and can synchronize to external master pulses. Option 021 is

recommended for forward-only pulsed-RF measurements, and Options 021 and 022 are recommended for bi-directional pulsed-RF measurements. The N1966A Pulse I/O adapter is recommended if using external master pulses or external pulse modulators.

Add pulse modulator to internal first source

(Option 021) PNA-X PNA ~~PNA~~

This option enables the internal pulse modulator on Source1 Out1. Control of the modulator can be done via pin 8 of the Pulse I/O D-sub connector on the rear panel of the analyzer using an external pulse generator, or by using one of the internal pulse generators enabled with S93025/26A. The N1966A pulse I/O adapter is recommended if using an external pulse generator.

Add pulse modulator to internal second source

(Option 022) PNA-X PNA ~~PNA~~

This option enables the internal pulse modulator on Source2 Out1. Control of the modulator can be done via pin 8 of the Pulse I/O D-sub connector on the rear panel of the analyzer using an external pulse generator, or by using one of the internal pulse generators enabled with S93025/26A. The N1966A pulse I/O adapter is recommended if using an external pulse generator. Requires one of text set options 22x or 4xx.

Add IF inputs for antenna and millimeter-wave

(Option 020) PNA-X PNA ~~PNA~~

This option enables external IF inputs on the rear panel of the analyzer for applications such as antenna test and for use with millimeter-wave test set controllers (for more information about millimeter-wave network analyzer configurations, see Millimeter-Wave Network Analyzers Technical Overview, 5989-7620EN).

Fast CW Sweep (Option 118)

PNA-X PNA ~~PNA~~

This option uses a FIFO (first-in first-out) buffer to allow external point-trigger acquisition of 400,000 data points per second on five measurement receivers. When enabled, there is no display update, no background computation, or other interference from the vector network analyzer application. All the data gathered is placed into a 500-million-point FIFO buffer. Data may be read from the FIFO buffer at the same time as it is filled.

Nonlinear vector network analysis

Please refer to 5989-8575EN *Nonlinear Vector Network Analyzer Brochure* for more information.



PNA Family Applications and Options (continued)

Accessories

Solid black series name indicates the feature is available on that series, while gray series name with strikethrough indicates the feature is not available on that series. For example:

PNA: Available on PNA Series
~~PNA~~: Not available on PNA Series

Rack mount kit without handles (Option 1CM)

PNA-X PNA ~~PNA-L~~

Adds a rack mount flange kit 1CM042A and a rail kit (E3663AC) for use without handles.

Rack mount kit with handles (Option 1CP)

PNA-X PNA ~~PNA-L~~

Adds handles (5063-1542), a rack mount flange kit (5063-1572) and a rail kit (E3663AC) for use with handles.

Pulse I/O adapter (N1966A)

PNA-X PNA ~~PNA-L~~

This adapter enables coaxial connections between the Pulse I/O D-sub connector on the rear panel of the analyzer and the coaxial inputs and outputs of external pulse generators and external pulse modulators. Coaxial connectors are SMB-male. The PULSE IN connectors are for controlling the analyzer's internal IF gates, which are enabled with S93026A and used with narrowband detection. The PULSE OUT connectors are from the four internal pulse generators, which are enabled with S93025/26A. The PULSE SYNC IN connector is used to synchronize the internal pulse generators with an external timing pulse. The RF PULSE MOD IN connector controls the internal pulse modulator(s) which are enabled with Options 021 and 022.



Pulse I/O adapter (N1966A) simplifies connections

Comb Generators

U9391C 10 MHz to 26.5 GHz
 U9391F 10 MHz to 50 GHz
 U9391G 10 MHz to 67 GHz

PNA-X PNA ~~PNA-L~~



The U9391C/F/G provides precision phase calibration, traceable to the National Institute of Standards and Technology (NIST) standard. It is used for nonlinear measurements with the PNA-X nonlinear vector network analyzer (NVNA). NVNA requires two comb generators, one is connected during measurements and another is used only during calibration. A comb generator is also used to characterize the VNA receivers for delay measurements of frequency converters using PNA-X or PNA instruments and the SMC+Phase measurement class (part of S93083A).

CalPod calibration refresh modules (8553xB/4xA)

PNA-X PNA ~~PNA-L~~

CalPod calibration refresh modules allow in-situ calibration refreshes to be performed at the push of a button without removing the DUT or re-connecting calibration standards. CalPods are designed for any measurement situation where it is desirable to ensure that a valid calibration is present before recording measurement data. For example, they are useful for removing environmental effects such as cable movement and thermal-based changes of cables, connectors, and adapters, as well as connector and switch-matrix repeatability errors. The modules are especially useful in temperature, or thermal-vacuum chamber testing. CalPod modules are equipped with 2.92 mm connectors.

- 85530B 20 GHz ambient-temperature CalPod
- 85531B 20 GHz temperature-compensated CalPod
- 85532B 20 GHz thermal-vacuum compatible CalPod
- 85540A 40 GHz ambient-temperature CalPod
- 85541A 40 GHz temperature-compensated CalPod
- 85542A 40 GHz thermal-vacuum compatible CalPod
- 85523B CalPod controller (provides control for up to 4 CalPods)
- 85556A CalPod drive-cable splitter (allows control for up to 12 CalPods)
- 85554A CalPod drive cable extension (10-meter cascable extension cable)



PNA Family Network Analyzer Upgrade Kits

Frequency, test ports, test set and power configurations

Upgrade kits are available to add options after initial purchase. To upgrade the PNA-X/PNA/PNA-L, order the corresponding item number. The model and serial numbers of the instrument to be retrofitted are required as part of the order. To add application software, order the appropriate standalone model numbers shown in the tables on pages 6 and 7.

Description	Required Option	For PNA-X Series	For PNA Series	For PNA-L Series	User Installable
Frequency upgrade¹					
Extend analyzer's frequency range to 13.5 GHz	N5239/49B	N5249BU-613	n/a	N5239BU-613	No
Extend analyzer's frequency range to 20 GHz	N5231/39B	n/a	n/a	N5231/39BU-620	No
Extend analyzer's frequency range to 26.5 GHz	N5221/41/49B	N5241/49BU-626	N5221BU-626	n/a	No
Extend analyzer's frequency range to 50 GHz	N5224/34/44B	N5244BU-650	N5224BU-650	N5234BU-650	No
Test ports					
Expand 2-ports, single source without configurable test set to 4-ports	N522xB-200	n/a	N522xBU-600	n/a	No
Expand 2-ports, single source with configurable test set to 4-ports	N522x/4xB-201	N524xBU-601	N522xBU-601	n/a	No
Expand 2-ports, single source with configurable test set and extended power range to 4-ports	N522x/4xB-217	N524xBU-617	N522xBU-617	n/a	No
Expand 2-ports, single source with configurable test set, extended power range, and bias-tees to 4-ports	N522x/4xB-219	N524xBU-619	N522xBU-619	n/a	No
Expand 2-ports, internal second source with configurable test set, extended power range, combiner, and mechanical switches to 4-ports	N524xB-222	N524xBU-622	n/a	n/a	No
Expand 2-ports, internal second source with configurable test set, extended power range, bias-tees, combiner, and mechanical switches to 4-ports	N524xB-224	N524xBU-623	n/a	n/a	No
Test set and power configuration					
Add configurable test set, 2-ports	N522xB-200	n/a	N522xBU-201	n/a	No
Add configurable test set and source attenuators, 2-ports	N523xB-200	n/a	n/a	N523xBU-216	No
Add low frequency extension, 2-ports	N5222/27B-201	n/a	N5222/27BU-205	n/a	No
Add extended power range, 2-ports ²	N522x/4xB-201	N524xBU-217	N522xBU-217	n/a	No
Add bias-tees, 2-ports ²	N522x/4xB-217 or N524xB-222	N524xBU-219	N522xBU-219	n/a	No
Add internal 2nd source, combiner and mechanical switches, 2-ports	N524xB-217/219	N524xBU-224	n/a	n/a	No
Add configurable test set, 4-ports	N522xB-400	n/a	N522xBU-401	n/a	No
Add configurable test set and source attenuators, 4-ports	N523xB-400	n/a	n/a	N523xBU-416	No
Add extended power range, 4-ports ²	N522x/4xB-401	N524xBU-417	N522xBU-417	n/a	No
Add bias-tees, 4-ports ²	N522x/4xB-417 or N524xB-422	N524xBU-419	N522xBU-419	n/a	No
Add internal combiner and mechanical switches, 4-ports	N524xB-417/419	N524xBU-423	n/a	n/a	No
Add low frequency extension, 4-ports	N5242/47B-423	N5242/47BU-425	n/a	n/a	No
Pulse, antenna, mm-wave					
Add pulse modulator to internal 1st source		N524xBU-021	N522xBU-021	n/a	Yes
Add pulse modulator to internal 2nd source	Requires one of Options 22x, 40x, 41x, or 42x	N524xBU-022	N522xBU-022	n/a	Yes
Add IF inputs		N524xBU-020	N522xBU-020	n/a	Yes
A to B model upgrades					
The A to B model upgrade kit includes a new front-panel assembly with 12.1" multi-touch display, a new solid-state hard drive, and a new instrument cover and handles with Keysight's dark-gray color scheme ³ .		N524xAU-690	N522xAU-690	N523xAU-690	No

1. Frequency upgrade options from 8.5/13.5/20/26.5 GHz to 43.5/50 GHz and 43.5/50 GHz to 67 GHz are not available. Trade-in is recommended.

2. Not available on N5227/47B.

3. May also require update of CPU, SPAM, and synthesizer assemblies, supplied in separate upgrade kits. For more information, visit na.support.keysight.com/pna



PNA Family Network Analyzer Upgrade Kits (continued)

Upgrade paths

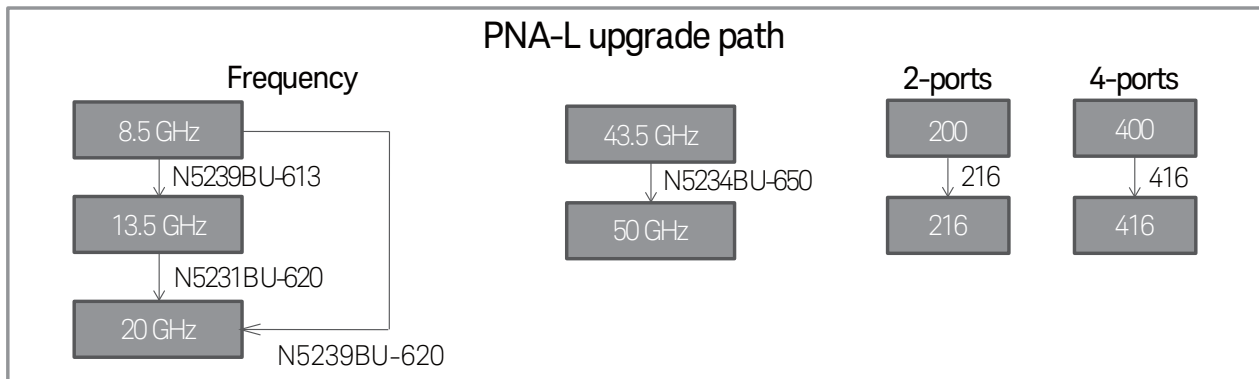
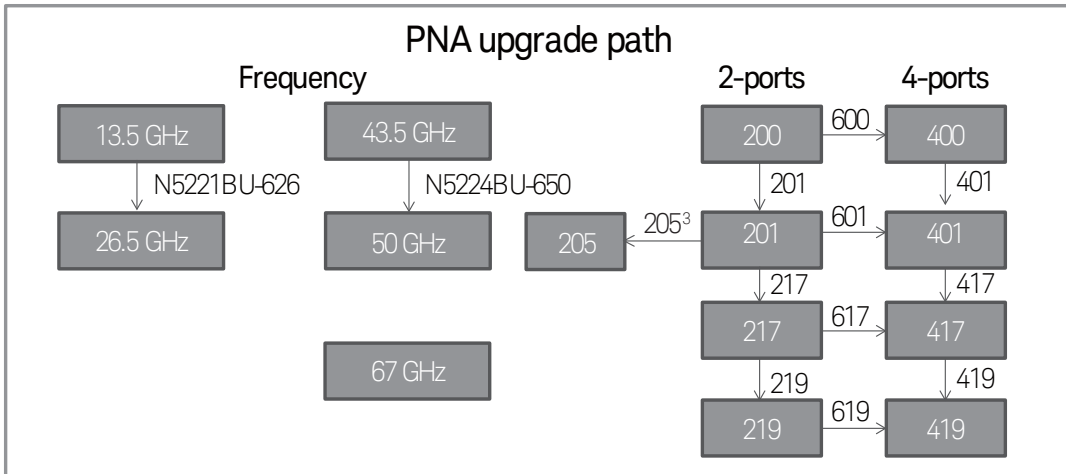
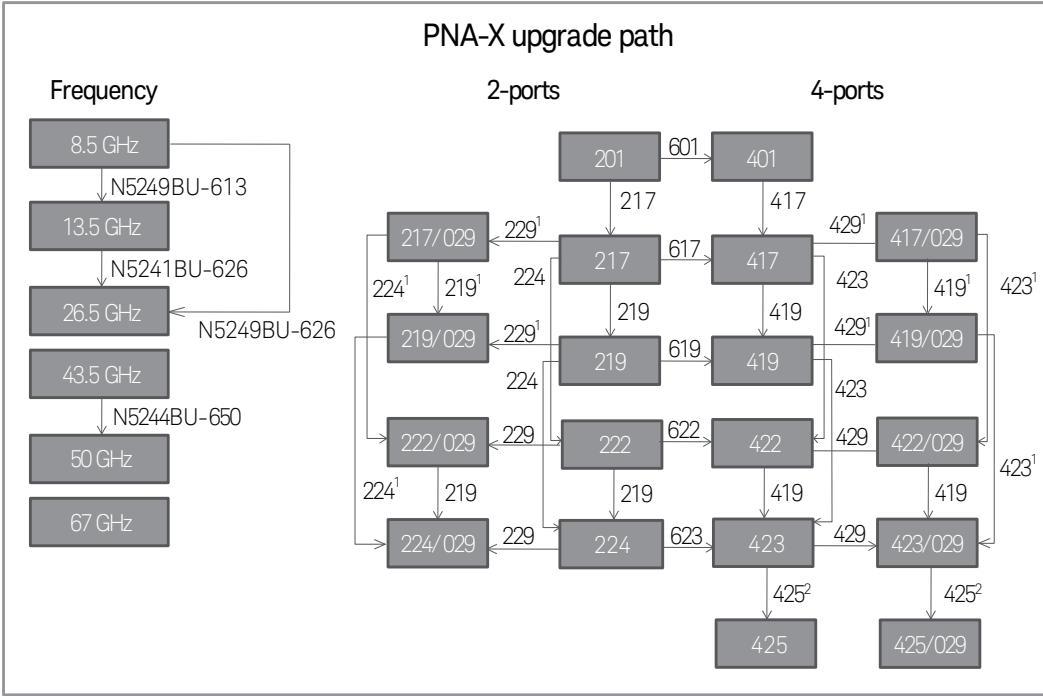

1. This upgrade path only available for N5241/42/49B.
2. This upgrade path only available for N5242B with or without low-noise receiver Option 029, and for N5247B with Option 029.
3. This upgrade path only available for N5222/27B.



Applications

Material measurements

The Keysight N1500A materials measurement suite streamlines the process of measuring complex permittivity and permeability with a network analyzer. Various type of measurements, such as transmission line and free space, arch reflectivity, resonant cavity, and coaxial probe are available as options. The easy-to-use software guides the user through setup and measurement, instantly converting S-parameter network analyzer data into the data format of your choice and displaying the results within seconds. Results can be charted in a variety of formats: ϵ_r , ϵ_r'' , $\tan\delta$, μ_r , μ_r'' , $\tan\delta_{\mu}$, and Cole-Cole.

Signal integrity measurements

N1930B Physical Layer Test System (PLTS) Software

The PLTS software platform has become an industry standard for calibration, measurement, and analysis of linear passive interconnects such as cables, connectors, backplanes, and printed circuit boards. Utilizing either a vector network analyzer (VNA) or a time domain reflectometer (TDR), fast and accurate measurements can be obtained without in-depth knowledge of microwave measurement techniques. Refer to www.keysight.com/find/plts or the technical overview (literature number 5989-6841EN) for more details.

Multiport measurements

Multiport test sets are designed to work with the PNA family of network analyzers to provide a single set of connections to devices with more than four ports. Test sets come with different port counts and frequency ranges, and are built to work with 2- or 4-port network analyzers. They are configured as switching or extension test sets, using electro-mechanical or solid-state switches.

Test set types: switching and extension

Switching test sets provide an economical solution for RF applications. They are connected directly to the test ports of the VNA, and a group of test ports share the directional couplers and receivers in the VNA. Extension test sets are connected to the sources and test receivers through the configurable test set of the VNA. They feature a directional coupler for every test port, and all switching occurs behind the directional couplers, providing the ultimate in flexibility, stability, and performance for RF and microwave applications.

Switch types: electro-mechanical and solid-state

Electro-mechanical switches have less insertion loss, higher power handling, and a more linear response compared to solid-state switches. They are recommended for testing active devices, high-power devices, and devices that require wide dynamic range. However, they have limited switching life (mostly 5 million cycles) and long setting times. In contrast, solid-state switches have unlimited switching life, very fast switching speed, and excellent repeatability. Thus, they are often used for high-volume S-parameter measurements of passive devices.

Test set model number

Multiport test set model numbers represent the type of test set; note the numbering scheme below.

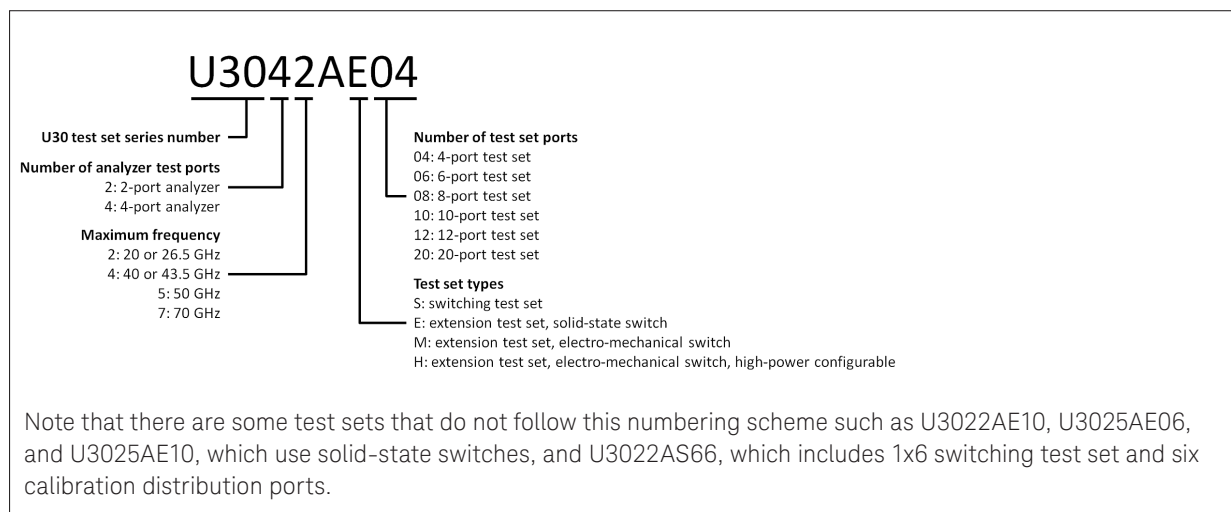

Applications (continued)

Test set options

One of the following test set options must be selected.

Standard configuration (Option 700)

- The standard configuration is the basic test set configuration, which does not include signal conditioning devices such as amplifiers.

Add amplifiers for improved dynamic range (Option 001)

- Option 001 adds an amplifier between each test port coupler and the receiver switch to improve system dynamic range. It is primarily offered for test sets with solid-state switches, to compensate for insertion loss.

Add amplifiers and bias-tees (Option 002)

- Option 002 adds an amplifier between each test port coupler and the receiver switch to improve system dynamic range, and adds bias-tees for all test ports on the test set as well as the analyzer. It is primarily offered for test sets with solid-state switches to compensate for insertion loss.

Interface kits

The interface kit includes a set of semi-rigid RF jumper cables and two pairs of rear locking feet that connect and lock the analyzer and the test set together. When ordering a multiport test set, the analyzer that is used with the test set must be specified to add one of the following interface kits. The availability depends on the test set model. There are following three interface kit models based on the jumper connector layouts on the test set. Therefore, only one interface kit model (“PX”, “PN”, or “PL”) is available on each test set. Each interface kit model has one digit suffix indicating the connector type; 1 for 1.85 mm, 2 for 2.4 mm and 3 for 3.5 mm (or SMA).

U3021PXx	Interface kit for test set with jumper connectors to align with N524xB PNA-X and N522xB PNA
U3021PNx	Interface kit for test set with jumper connectors to align with E836xB/C PNA and N5230A/C-x25 2-port PNA-L
U3021PLx	Interface kit for test set with jumper connectors to align with N523xA/B-416 4-port PNA-L
Option 261	For use with E8361A/C 2-port PNA
Option 262	For use with E8362B/C 2-port PNA, or N5230A/C-225 or N523xA/B-216 2-port PNA-L
Option 263	For use with E8363B/3C/4B/4C 2-port PNA, or N5230A/C-425/525 2-port PNA-L
Option 430	For use with N5230A/C-425/426 or N523xA/B-416
Option 242	For use with N5221/22/41/42/49B-2xx 2-port PNA/PNA-X
Option 442	For use with N5221/22/41/42/49B-4xx 4-port PNA/PNA-X
Option 245	For use with N5224/25/44/45B-2xx 2-port PNA/PNA-X
Option 445	For use with N5224/25/44/45B-4xx 4-port PNA/PNA-X
Option 247	For use with N5227/47B-2xx 2-port PNA/PNA-X
Option 447	For use with N5227/47B-4xx 4-port PNA/PNA-X

When ordering an additional cable set, a spare cable or rear locking feet, refer to the multiport test set user's guide or go to: www.keysight.com/find/multiport

Millimeter-wave measurements

N5290/91A single-sweep millimeter-wave solutions

PNA (N522xB) and PNA-X (N524xB) network analyzers can be transformed into single-sweep solutions that operate from 900 Hz to 110 GHz (N5290A), or up to 120 GHz with over-range capability to 125 GHz (N5291A). The N5290/91A solutions come fully configured around the PNA/PNA-X network analyzers, and include a millimeter-wave test set controller (N5292A), frequency-extender modules (N5293/95AXxx), and the necessary cables to allow users to make either 2- or 4-port measurements over the entire frequency range. The broadband N5290/91A millimeter-wave solutions provide high-performance measurement capability complimented by measurement applications from the PNA/PNA-X that include pulsed-RF, gain compression, 4-port true-differential, scalar mixer/converter measurements, and spectrum analysis.

Banded waveguide solutions to 1.5 THz

Banded waveguide millimeter-wave solutions cover waveguide bands from 50 GHz to 1.5 THz. A 2- or 4-port PNA or PNA-X in conjunction with an N5292A millimeter-wave controller (with either a 2- or 4-port option), provides complete millimeter-wave solutions. These systems are configured with a PNA or PNA-X which has IF inputs (Option 020), and a configurable test set (one of Options 201/217/219/222/224/401/417/419/422/423). In addition, frequency-offset capability is required from one of software models S93029/080/082/083/084/086/087/089/090x/093/094A. When configured with the N5292A millimeter-wave controller, a special cable adapter will be required to connect the RF, LO, and IF signals from the banded millimeter-wave extenders to the controller. A separate DC power supply is also required to power the frequency extenders.

For a complete list of millimeter-wave products and options, and ordering instructions, please refer to the N5290/91A Millimeter-Wave Network Analyzer Configuration Guide (5992-2179EN), and the Banded Millimeter-Wave Network Analyzers to 1.5 THz Technical Overview (5992-2177EN).



Measurement Accessories

A complete list of RF and microwave test accessories is available on our Web site: www.keysight.com/find/mta

Accessories are available in these connector types: 50 Ω Type-N, 3.5 mm, 7 mm, 2.4 mm, 2.92 mm, 1.85 mm, 1.0 mm, and waveguide. Test port cables and a calibration kit should be added for a complete measurement system. A verification kit is used to verify corrected system performance.

Cables and adapter sets

Keysight offers cables in the following types:

- single cables in semi-rigid and flexible
- cable sets in semi-rigid and flexible

There are also adapter sets available that protect the test port and convert the port to the desired connector interface. These kits contain:

- one male adapter
- one female adapter

To attain the best mechanical rigidity for device connection, use a single cable and the appropriate special adapter set. To attain the greatest flexibility for device connection, use a cable set.

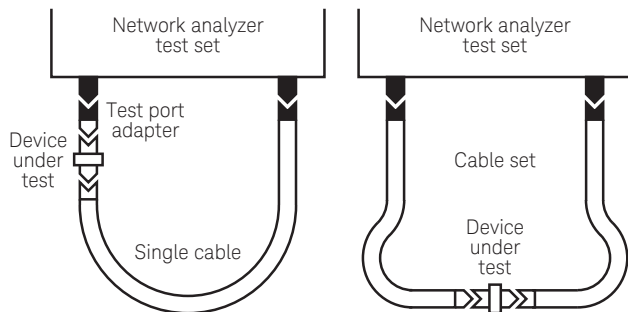

Calibration kits

Coaxial measurements

Mechanical calibration kits include standards, such as opens, shorts and loads, which are measured by the network analyzer for increased measurement accuracy.

Choose a calibration kit for each connector type to be used.

Economy, includes:

- open standards (male and female)
- short standards (male and female)
- fixed-termination standards (male and female)

Standard, includes the devices in the economy kit and adds:

- sliding load standards (male and female) or a series of offset shorts

Precision, includes the devices in the economy kit and adds:

- 50 Ω airline(s) for TRL calibration
- TRL adapters

Electronic calibration (ECal) kits replace mechanical calibration standards with one solid-state calibration module that is controlled by the network analyzer via USB, to present many different impedances to the test ports. A full two-port calibration can be performed quickly with a single connection. This technique reduces operator errors and connector wear and abrasion.

For more information about ECal modules, refer to the technical overview 5963-3743E (N4690, 85090, and N4430 Series).

Waveguide measurements

For waveguide measurements, Keysight offers mechanical calibration kits that include:

- waveguide-to-coax adapters (X, P, K, R, Q, U, V)
- precision waveguide section
- flush short circuit
- fixed terminations
- straight section



For devices with 1.0 mm connectors

Mechanical calibration/verification kit

85059B DC to 120 GHz precision calibration kit.

Includes:

- 85059-60027 1.0 mm (m) short, 1.3 mm
- 85059-60029 1.0 mm (m) short, 2.45 mm
- 85059-60031 1.0 mm (m) short, 3.326 mm
- 85059-60033 1.0 mm (m) short, 4.039 mm
- 85059-60028 1.0 mm (f) short, 1.3 mm
- 85059-60030 1.0 mm (f) short, 2.45 mm
- 85059-60032 1.0 mm (f) short, 3.326 mm
- 85059-60034 1.0 mm (f) short, 4.039 mm
- 85059-60053 1.0 mm (m) open
- 85059-60054 1.0 mm (f) open
- 85059-60019 1.0 mm (m) 50 GHz load
- 85059-60020 1.0 mm (f) 50 GHz load
- 85059-60044 1.0 mm m-m adapter
- 85059-60045 1.0 mm f-f adapter
- 85059-60046 1.0 mm m-f adapter
- 8710-2812 6 mm 4 in-lb torque wrench
- 8710-2813 14 mm 4 in-lb torque wrench
- 8710-2156 6 mm open-end wrench

Cables

- 11500I 1.0 mm (f-f) test port cable (8.8 cm)
- 11500J 1.0 mm (m-f) test port cable (16.0 cm)¹
- 11500K 1.0 mm (m-f) test port cable (20.0 cm)¹
- 11500L 1.0 mm (m-f) test port cable (24.0 cm)¹

Adapter set

- V281C 1.0 mm(f) to V-band waveguide adapter
- V281D 1.0 mm (m) to V-band waveguide adapter
- W281C 1.0 mm (f) to W-band waveguide adapter
- W281D 1.0 mm (m) to W-band waveguide adapter
- 11920A 1.0 mm (m) to 1.0 mm (m) adapter
- 11920B 1.0 mm (f) to 1.0 mm (f) adapter
- 11920C 1.0 mm (m) to 1.0 mm (f) adapter
- 11921A 1.0 mm (m) to 1.85 mm (m) adapter
- 11921B 1.0 mm (f) to 1.85 mm (f) adapter
- 11921C 1.0 mm (m) to 1.85 mm (f) adapter
- 11921D 1.0 mm (f) to 1.85 mm (m) adapter
- 11922A 1.0 mm (m) to 2.4 mm (m) adapter
- 11922B 1.0 mm (f) to 2.4 mm (f) adapter
- 11922C 1.0 mm (m) to 2.4 mm (f) adapter
- 11922D 1.0 mm (f) to 2.4 mm (m) adapter
- 11923A 1.0 mm (f) connector launch assembly

1. For on-wafer applications, two 11500J/K/L cables are required; one cable for each test port.
2. Special rugged female connector specifically for connecting to the network analyzer test port, but does not mate with a standard male connector.

For devices with 1.85 mm connectors

Mechanical calibration kit

85058B standard: DC to 67 GHz. Includes:

- 85058-60101 1.85 mm (m) short 5.4 mm
- 85058-60102 1.85 mm (m) short 6.3 mm
- 85058-60103 1.85 mm (m) short 7.12 mm
- 85058-60104 1.85 mm (m) short 7.6 mm
- 85058-60105 1.85 mm (f) short 5.4 mm
- 85058-60106 1.85 mm (f) short 6.3 mm
- 85058-60107 1.85 mm (f) short 7.12 mm
- 85058-60108 1.85 mm (f) short 7.6 mm
- 85058-60109 1.85 mm male open
- 85058-60110 1.85 mm female open
- 85058-60111 1.85 mm male load
- 85058-60112 1.85 mm female load
- 85058-60113 1.85 mm (m) to 1.85 mm (m) adapter
- 85058-60114 1.85 mm (f) to 1.85 mm (f) adapter
- 85058-60115 1.85 mm (m) to 1.85 mm (f) adapter

85058E economy: DC to 67 GHz. Includes:

- 85058-60101 1.85 mm (m) short 5.4 mm
- 85058-60105 1.85 mm (f) short 5.4 mm
- 85058-60109 1.85 mm male open
- 85058-60110 1.85 mm female open
- 85058-60123 1.85 mm male load
- 85058-60124 1.85 mm female load
- 85058-60113 1.85 mm (m) to 1.85 mm (m) adapter
- 85058-60114 1.85 mm (f) to 1.85 mm (f) adapter
- 85058-60115 1.85 mm (m) to 1.85 mm (f) adapter

Electronic calibration kits

N4694A Microwave ECal: 10 MHz to 67 GHz, 2-ports. Includes:

- Option M0F module with:
 - N4694-60001 1.85 mm (f) to 1.85 mm (m) ECal module
- Option O0M module with:
 - N4694-60002 1.85 mm (m) to 1.85 mm (m) ECal module
- Option O0F module with:
 - N4694-60003 1.85 mm (f) to 1.85 mm (f) ECal module
- Option O0A adds:
 - 85058-60113 1.85 mm (m) to 1.85 mm (m) adapter
 - 85058-60114 1.85 mm (f) to 1.85 mm (f) adapter
- Option 150: Replaces standard storage container with a wooden box

Cables

- N4697E² Single, flexible:
 - 1.85 mm (f) to 1.85 mm (f), 96.5 cm, 38 inches
- N4697F² Set, flexible:
 - One 1.85 mm (f) to 1.85 mm (f) cable, 62.2 cm, 24.5 inches, p/n N4697-60100
 - One 1.85 mm (f) to 1.85 mm (m) cable, 62.2 cm, 24.5 inches, p/n N4697-60200
- N4421B-K67 Single, flexible:
 - 1.85 mm (f) to 1.85 mm (m), 91.4 cm, 36 inches

Adapter set

- 85130H² 1.85 mm to 1.85 mm



For devices with 2.4 mm connectors

Mechanical calibration kit

85056A standard: DC to 50 GHz. Includes:

- 00901-60003 2.4 mm (m) fixed broadband load
- 00902-60004 2.4 mm (f) fixed broadband load
- 00915-60003 2.4 mm (m) sliding load
- 00915-60004 2.4 mm (f) sliding load
- 85056-60005 2.4 mm (m) to 2.4 mm (m) adapter
- 85056-60006 2.4 mm (f) to 2.4 mm (f) adapter
- 85056-60007 2.4 mm (m) to 2.4 mm (f) adapter
- 85056-60020 2.4 mm (m) short
- 85056-60021 2.4 mm (f) short
- 85056-60022 2.4 mm (m) open
- 85056-60023 2.4 mm (f) open

85056D economy: DC to 50 GHz. Includes:

- 00901-60003 2.4 mm (m) fixed broadband load
- 00902-60004 2.4 mm (f) fixed broadband load
- 85056-60005 2.4 mm (m) to 2.4 mm (m) adapter
- 85056-60006 2.4 mm (f) to 2.4 mm (f) adapter
- 85056-60007 2.4 mm (m) to 2.4 mm (f) adapter
- 85056-60020 2.4 mm (m) short
- 85056-60021 2.4 mm (f) short
- 85056-60022 2.4 mm (m) open
- 85056-60023 2.4 mm (f) open

Electronic calibration kits

N4693A Microwave ECal: 10 MHz to 50 GHz, 2-ports.

Includes:

- Option M0F module with:
N4693-60001 2.4 mm (f) to 2.4 mm (m) ECal module
- Option 00M module with:
N4693-60002 2.4 mm (m) to 2.4 mm (m) ECal module
- Option 00F module with:
N4693-60003 2.4 mm (f) to 2.4 mm (f) ECal module
- Option 00A adds:
 - 85056-60005 2.4 mm (m) to 2.4 mm (m) adapter
 - 85056-60006 2.4 mm (f) to 2.4 mm (f) adapter
- Option 150: Replaces standard storage container with a wooden box

Cables

Note: Keysight offers the following 2.4 mm test port cables. Adapters will be necessary when using these cables for 2.92 mm measurements.

- 85133C¹ single, semi-rigid:
2.4 mm (f) to PSC-2.4 mm (f), 81 cm, 32 inches
- 85133D¹ set, semi-rigid:
One 2.4 mm (f) to 2.4 mm (m), 53 cm, 21 inches, p/n 85133-60001
One 2.4 mm (f) to 2.4 mm (f), 53 cm, 21 inches, p/n 85133-60002
- 85133E¹ single, flexible:
2.4 mm (f) to PSC-2.4 mm (f), 97 cm, 38 inches

- 85133F¹ set, flexible:
One 2.4 mm (f) to 2.4 mm (f), 63 cm, 25 inches, p/n 85133-60016
One 2.4 mm (f) to 2.4 mm (m), 63 cm, 25 inches, p/n 85133-60017
- 85133H¹ Single, flexible: 2.4 mm (f) to 2.4 mm (m), 63 cm, 25 inches
- N4421AK20 Single, flexible: 2.4 mm (f) to 2.4 mm (m), 91.4 cm, 36 inches

Adapter set

- 85130E 2.4 mm¹ to 7 mm
- 85130F 2.4 mm¹ to 3.5 mm
- 85130G 2.4 mm¹ to 2.4 mm

For devices with K connectors (2.92 mm)

Mechanical calibration kits

85056KE01 DC to 40 GHz

For use with user supplied 2.9 mm test port cables. 2.92 mm (K connector) calibration kit with fixed and sliding loads. The Keysight 85056KE01 calibration kit is an ordering convenience to allow the pass through ordering from Keysight for the Maury 8770C47 calibration kit.

85056KE02 DC to 40 GHz

For use with user supplied 2.92 mm test ports cables. 2.92 mm (K connector) calibration kit with fixed loads only. The Keysight 85056KE02 calibration kit is an ordering convenience to allow the pass through ordering from Keysight for the Maury 8770D47 calibration kit.

The 85056KE01 and 85056KE02 contains one NMD 2.4 mm² (f) to 2.92 mm (f) and one NMD 2.4 mm² (f) to 2.92 mm (m) test port adapter to adapt the 2.4 mm test ports of the PNA to 2.92 mm. It also supplies 2.92 mm to 2.92 mm in-series adapters (3 adapters) and a PNA Cal Coefficients on a USB stick. Users must supply their own 2.92 mm or K-connector test port cables. Also included is a 2.92 mm torque wrench.

Maury Microwave Terms and Conditions for Warranty and Return apply. Maury Microwave Corp. calibration kits are to be returned directly to Maury Microwave for service, repair, or calibration issues and not to Keysight Technologies. For additional information go to www.maury Microwave.com.

Keysight Technologies does not guarantee the performance of the Maury calibration kits or the system performance when connected to Keysight Microwave PNA Series network analyzers.

1. Special rugged female connector specifically for connecting to the network analyzer test port, but does not mate with a standard male connector.

2. Special rugged female connector specifically for connecting to the network analyzer test port, but does not mate with standard 2.4 mm male connector



For devices with K connectors (2.92 mm), continued

Mechanical calibration kits, continued

Electronic calibration kits

N4692A Microwave ECal: 10 MHz to 40 GHz, 2-ports.

Includes:

- Option M0F module with: N4692-60001 2.92 mm (f) to 2.92 mm (m) ECal module
- Option 00M module with: N4692-60002 2.92 mm (m) to 2.92 mm (m) ECal module
- Option 00F module with: N4692-60003 2.92 mm (f) to 2.92 mm (f) ECal module
- Option 00A adds:
 - N4692-60021 2.92 mm (m) to 2.92 mm (m) adapter
 - N4692-60022 2.92 mm (f) to 2.92 mm (f) adapter
- Option 150: Replaces standard storage container with a wooden box

Cables

Note: Keysight offers the following 2.4 mm test port cables. Adapters will be necessary when using these cables for 2.92 mm measurements.

- 85133C¹ single, semi-rigid: 2.4 mm (f) to PSC-2.4 mm (f), 81 cm, 32 inches
- 85133D¹ set, semi-rigid:
 - One 2.4 mm (f) to 2.4 mm (m), 53 cm, 21 inches, p/n 85133-60001
 - One 2.4 mm (f) to 2.4 mm (f), 53 cm, 21 inches, p/n 85133-60002
- 85133E¹ single, flexible: 2.4 mm (f) to PSC-2.4 mm (f), 97 cm, 38 inches
- 85133F¹ set, flexible:
 - One 2.4 mm (f) to 2.4 mm (f), 63 cm, 25 inches, p/n 85133-60016
 - One 2.4 mm (f) to 2.4 mm (m), 63 cm, 25 inches, p/n 85133-60017
- 85133H¹ Single, flexible: 2.4 mm (f) to 2.4 mm (m), 63 cm, 25 inches
- N4421AK20 Single, flexible: 2.4 mm (f) to 2.4 mm (m), 91.4 cm, 36 inches

Adapters

- 11904A 2.4 mm (m) to 2.92 mm (m)
- 11904B 2.4 mm (f) to 2.92 mm (f)
- 11904C 2.4 mm (m) to 2.92 mm (f)
- 11904D 2.4 mm (f) to 2.92 mm (m)
- 11904S 2.4 mm to 2.92 mm
- Adapter set, contains 4 matched adapters

1. Special rugged female connector specifically for connecting to the network analyzer test port, but does not mate with a standard male connector.

For devices with 3.5 mm or SMA connectors

Mechanical calibration kits

85052B standard: DC to 26.5 GHz. Includes:

- 00902-60003 3.5 mm (m) fixed load
- 00902-60004 3.5 mm (f) fixed load
- 00911-60019 3.5 mm (m) sliding load
- 00911-60020 3.5 mm (f) sliding load
- 85052-60006 3.5 mm (m) short
- 85052-60007 3.5 mm (f) short
- 85052-60008 3.5 mm (m) open
- 85052-60009 3.5 mm (f) open
- 85052-60012 3.5 mm (f) to 3.5 mm (f) adapter
- 85052-60013 3.5 mm (f) to 3.5 mm (m) adapter
- 85052-60014 3.5 mm (m) to 3.5 mm (m) adapter

85052C precision TRL: DC to 26.5 GHz. Includes:

- 00902-60003 3.5 mm (m) fixed load
- 00902-60004 3.5 mm (f) fixed load
- 85052-60006 3.5 mm (m) short
- 85052-60007 3.5 mm (f) short
- 85052-60008 3.5 mm (m) open
- 85052-60009 3.5 mm (f) open
- 85052-60032 3.5 mm (f) to 3.5 mm (f) adapter
- 85052-60033 3.5 mm (m) to 3.5 mm (m) adapter
- 85052-60034 3.5 mm (f) to 3.5 mm (m) adapter
- 85052-60035 3.5 mm short TRL line
- 85052-60036 3.5 mm long TRL line

85052D economy: DC to 26.5 GHz. Includes:

- 00902-60003 3.5 mm (m) fixed load
- 00902-60004 3.5 mm (f) fixed load
- 85052-60006 3.5 mm (m) short
- 85052-60007 3.5 mm (f) short
- 85052-60008 3.5 mm (m) open
- 85052-60009 3.5 mm (f) open
- 85052-60012 3.5 mm (f) to 3.5 mm (f) adapter
- 85052-60013 3.5 mm (f) to 3.5 mm (m) adapter
- 85052-60014 3.5 mm (m) to 3.5 mm (m) adapter

Electronic calibration kits

85093C RF ECal: 300 kHz to 9 GHz, 2-ports; Standard module includes:

- Option M0F with: 85093-60008 3.5 mm (f) to 3.5 mm (m) ECal module
- Option 00F module with: 85093-60010 3.5 mm (f) to 3.5 mm (f) ECal module
- Option 00M module with: 85093-60009 3.5 mm (m) to 3.5 mm (m) ECal module
- Option 00A adds:
 - 85052-60012 3.5 mm (f) to 3.5 mm (f) adapter
 - 85052-60014 3.5 mm (m) to 3.5 mm (m) adapter
- Option 150: Replaces standard storage container with a wooden box



85093C-xxx mixed-connector options:

Port A option			Port B option					
Type	(f)	(m)	Type	(f)	(m)	Type	(f)	(m)
3.5 mm	101	102	Type-N 50 ohm	203	204	7-16	205	206

N4431B Microwave ECal: 300 kHz to 13.5 GHz, 4-ports.

Includes:

Option 010 module with: N4431-60006 4 x 3.5 mm (f) ECal module

N4431B-xxx mixed-connector options:

Connector type	Port A option	Port B option	Port C option	Port D option
3.5 mm (f)	101	201	301	401
3.5 mm (m)	102	202	302	402
Type-N 50 ohm (f)	103	203	303	403
Type-N 50 ohm (m)	104	204	304	404
7-16 (f)	105	205	305	405
7-16 (m)	106	206	306	406

Option 150: Replaces standard storage container with a wooden box

N4433A Microwave ECal: 300 kHz to 20 GHz, 4-ports.

Includes:

Option 010 module with: N4433-60003 4 x 3.5 mm (f) ECal module

N4433A-xxx mixed-connector options:

Connector type	Port A option	Port B option	Port C option	Port D option
3.5 mm (f)	101	201	301	401
3.5 mm (m)	102	202	302	402

Option 150: Replaces standard storage container with a wooden box

N4691B Microwave ECal: 300 kHz to 26.5 GHz, 2-ports.

Includes:

- Option M0F module with:
N4691-60004 3.5 mm (f) to 3.5 mm (m) ECal module
- Option 00M module with:
N4691-60005 3.5 mm (m) to 3.5 mm (m) ECal module
- Option 00F module with:
N4691-60006 3.5 mm (f) to 3.5 mm (f) ECal module
- Option 00A adds:
 - 85052-60012 3.5 mm (f) to 3.5 mm (f) adapter
 - 85052-60014 3.5 mm (m) to 3.5 mm (m) adapter
- Option 150: Replaces standard storage container with a wooden box

Cables

- 85131C¹ single, semi-rigid: 3.5 mm (f) to PSC-3.5 mm (f), 81 cm, 32 inches
- 85131D¹ set, semi-rigid:
 - One 3.5 mm (f) to 3.5 mm (m), 53 cm, 21 inches, p/n 85131-60009
 - One 3.5 mm (f) to PSC-3.5 mm (f), 53 cm, 21 inches, p/n 85131-60010
- 85131E¹ single, flexible: 3.5 mm (f) to PSC-3.5 mm (f), 96.5 cm, 38 inches
- 85131F¹ set, flexible:
 - One 3.5 mm (f) to 3.5 mm (m), 62.2 cm, 24.5 inches, p/n 85131-60012
 - One 3.5 mm (f) to PSC-3.5 mm (f), 62.2 cm, 24.5 inches, p/n 85131-60013
- 85131H¹ single, flexible: 3.5 mm (f) to 3.5 mm (m), 62.2 cm, 24.5 inches
- 85134E¹ single, flexible: PSC-3.5 mm (f) to 2.4 mm (f), 96 cm, 38 inches
- 85134F¹ set, flexible:
 - One 2.4 mm (f) to PSC-3.5 mm (f), 53 cm, 21 inches, p/n 85134-60004
 - One 2.4 mm (f) to PSC-3.5 mm (m), 53 cm, 21 inches, p/n 85134-60003
- 85134H¹ single, flexible: 2.4 mm (f) to PSC-3.5 mm (m), 53 cm, 21 inches
- N4419AK20 single, flexible: 3.5 mm (m) to 3.5 mm (f), 91.4 cm, 36 inches
- Z5623A-K20 single, flexible: 3.5 mm (m) to 3.5 mm (m), 91.4 cm, 36 inches

Adapter sets

- 85130D 3.5 mm¹ to 3.5 mm

1. Special rugged female connector specifically for connecting to the network analyzer test port, but does not mate with a standard male connector.



For devices with Type-N connectors

Mechanical calibration kits

85054B standard: DC to 18 GHz. Includes:

- 00909-60011 Type-N (m) fixed lowband load
- 00909-60012 Type-N (f) fixed lowband load
- 85054-60025 Type-N (m) short
- 85054-60026 Type-N (f) short
- 85054-60027 Type-N (m) open
- 85054-60028 Type-N (f) open
- 85054-60031 Type-N (f) to 7mm adapter
- 85054-60032 Type-N (m) to 7mm adapter
- 85054-60037 Type-N (f) to Type-N (f) adapter
- 85054-60038 Type-N (m) to Type-N (m) adapter
- 85054-80010 Type-N (f) sliding load
- 85054-80009 Type-N (m) sliding load
- 85054-60050 Type-N (f) connector gage
- 85054-60052 Type-N (f) gage master
- 85054-60051 Type-N (m) connector gage
- 85054-60053 Type-N (m) gage master

85054D economy: DC to 18 GHz. Includes:

- 85054-60025 Type-N (m) short
- 85054-60026 Type-N (f) short
- 85054-60027 Type-N (m) open
- 85054-60028 Type-N (f) open
- 85054-60031 Type-N (f) to 7mm adapter
- 85054-60032 Type-N (m) to 7mm adapter
- 85054-60037 Type-N (f) to Type-N (f) adapter
- 85054-60038 Type-N (m) to Type-N (m) adapter
- 85054-60046 Type-N (m) fixed load
- 85054-60047 Type-N (f) fixed load

Adapter sets

- 85130C 3.5 mm to Type-N

Electronic calibration kits

N4431B Microwave ECal: 300 kHz to 13.5 GHz, 4-ports.

Includes:

- Option 020 module with:
N4431-60007 4 x Type-N (f) ECal module

N4431B-xxx mixed-connector options:

Connector type	Port A option	Port B option	Port C option	Port D option
3.5 mm (f)	101	201	301	401
3.5 mm (m)	102	202	302	402
Type-N 50 ohm (f)	103	203	303	403
Type-N 50 ohm (m)	104	204	304	404
7-16 (f) ¹	105	205	305	405
7-16 (m) ¹	106	206	306	406

Option 150: Replaces standard storage container with a wooden box

N4432A Microwave ECal: 300 kHz to 18 GHz, 4-ports. Includes:

- Option 020 module with:
N4432-60003 4 x Type-N (f) ECal module

N4432A-xxx mixed-connector options:

Connector type	Port A option	Port B option	Port C option	Port D option
3.5 mm (f)	101	201	301	401
3.5 mm (m)	102	202	302	402
Type-N 50 ohm (f)	103	203	303	403
Type-N 50 ohm (m)	104	204	304	404

Option 150: Replaces standard storage container with a wooden box

N4690B Microwave ECal: 300 kHz to 18 GHz, 2-ports.

Includes:

- Option M0F module with:
N4690-60004 Type-N (f) to Type-N (m) ECal module
- Option 00M module with:
N4690-60005 Type-N (m) to Type-N (m) ECal module
- Option 00F module with:
N4690-60006 Type-N (f) to Type-N (f) ECal module
- Option 00A adds:
85054-60037 Type-N (f) to Type-N (f) adapter
85054-60038 Type-N (m) to Type-N (m) adapter

Cables

Use the test port cables recommended for devices with 7 mm connectors, and 7 mm to Type-N adapters that are from the 85054B/D Type-N calibration kit (see 7 mm connector section).

Option 150: Replaces standard storage container with a wooden box

1. Special rugged female connector specifically for connecting to the network analyzer test port, but does not mate with a standard male connector.



For devices with 7 mm connectors

Mechanical calibration kits

85050B standard: DC to 18 GHz. Includes:

- 00909-60008 7 mm coax termination
- 85050-60006 7 mm fixed broadband load
- 85050-80007 7 mm short
- 85050-80010 7 mm open
- 85050-80011 7 mm sliding load

85050C precision TRL: DC to 18 GHz. Includes:

- 00909-60008 7 mm coax termination
- 85050-60003 7 mm to 7 mm airline
- 85050-60005 7 mm to 7 mm TRL adapter
- 85050-60006 7 mm fixed broadband load
- 85050-80008 7 mm short
- 85050-80009 7 mm short collet
- 85050-80010 7 mm open

85050D economy: DC to 18 GHz. Includes:

- 85050-60006 7 mm fixed broadband load
- 85050-80007 7 mm short
- 85050-80010 7 mm open

Electronic calibration kits

- N4696B Microwave ECal: 300 kHz to 18 GHz, 2-ports, 7 mm connectors
- Option 150: Replaces standard storage container with a wooden box

Cables

- 85132E single, flexible: 3.5 mm (f) to 7 mm, 97.2 cm, 38.25 inches¹
- 85132F set, flexible: two 3.5 mm (f) to 7 mm cables, 62.9 cm each, 24.75 inches each¹, p/n 85132-60004
- 85133F cable set (set, flexible, 2.4 mm, 53 cm each, 21 inches each)
- 85134F cable set (set, flexible, 2.4 mm (f) to 3.5 mm (f) and (m), 53 cm each, 21 inches each)
- 85135E single, flexible: 2.4 mm (f) to 7 mm, 96 cm, 38 inches
- 85135F set, flexible: two 2.4 mm (f) to 7 mm cables, 53 cm each, 21 inches each, p/n 85135-60002

Adapter sets

- 85130E 2.4 mm to 7 mm
- R281A adapter (2.4 mm (f) to WR-28 waveguide adapter)
- R281B adapter (2.4 mm (m) to WR-28 waveguide adapter)
- Q281A adapter (2.4 mm (f) to WR-22 waveguide adapter)
- Q281B adapter (2.4 mm (m) to WR-22 waveguide adapter)

1. Special rugged female connector specifically for connecting to the network analyzer test port, but does not mate with a standard male connector.

For devices with waveguide

Mechanical calibration kits

X Band

X11644A standard, WR-90: 8.2 to 12.4 GHz. Includes:

- 00896-60008 X-band standard section
- 00910-60003 X-band termination
- 11644-20018 X-band short
- 11644-20021 X-band shim
- X281C adapter (included in calibration kit): WR-90 to 7 mm

P Band

P11644A standard, WR-62: 12.4 to 18 GHz. Includes:

- 00896-60007 P-band standard section
- 00910-60002 P-band termination
- 11644-20017 P-band short
- 11644-20020 P-band shim
- P281C adapter (included in calibration kit): WR-62 to 7 mm

K Band

K11644A standard, WR-42: 18 to 26.5 GHz. Includes:

- 00896-60006 K-band standard section
- 00910-60001 K-band termination
- 11644-20016 K-band short
- 11644-20019 K-band shim
- K281C adapter (included in calibration kit): WR-42 to 3.5 mm (f) Option 012 WR-42 to 3.5 mm (m)

R Band

R11644A standard, WR-28: 26.5 to 40 GHz. Includes:

- 00914-20028 R-band termination
- 11644-20005 R-band short
- 11644-20003 R-band shim
- 11644-60001 R-band 10 cm straight waveguide
- 11644-60016 R-band 5 cm straight waveguide



Q Band

Q11644A standard, WR-22: 33 to 50 GHz. Includes:

- 11644-60005 Q-band termination
- 11644-20004 Q-band short
- 11644-20001 Q-band shim
- 11644-60002 Q-band 10 cm straight waveguide
- 11644-60017 Q-band 5 cm straight waveguide

U Band

U11644A standard, WR-19: 40 to 60 GHz. Includes:

- 11644-60006 U-band termination
- 11644-20004 U-band short
- 11644-20002 U-band shim
- 11644-60003 U-band 10 cm straight waveguide
- 11644-60018 U-band 5 cm straight waveguide

V Band

V11644A standard, WR-15: 50 to 75 GHz. Includes:

- 11644-60025 V-band termination
- 11644-20015 V/W-band short
- 11644-20013 V-band shim
- 11644-60012 V-band standard section

W Band

W11644A standard, WR-10: 75 to 110 GHz. Includes:

- 11643-60026 W-band termination
- 11644-20015 V/W-band short
- 11644-20014 W-band shim
- 11644-60013 W-band standard section

Verification kits

All Keysight verification kits include:

- precision Z_0 airline or match thru
- mismatched airline or mismatch thru
- fixed attenuators (except 85059V)
- traceable measured data and uncertainties

85051B 45 MHz to 18 GHz 7 mm kit

Includes attenuators, airline and mismatch airline with data on a USB drive for use in confirming calibrated system performance, traceable to national standards. Test procedure is provided in the service manual.

85053B 300 kHz to 26.5 GHz 3.5 mm kit

Includes attenuators, airline and mismatch airline with data on a USB drive for use in confirming calibrated system performance, traceable to national standards. Test procedure is provided in the service manual.

85055A 300 kHz to 18 GHz Type-N kit

Includes attenuators, airline and mismatch airline with data on a USB drive for use in confirming calibrated system performance, traceable to national standards. Test procedure is provided in the service manual.

85057B 45 MHz to 50 GHz 2.4 mm kit

Includes attenuators, airline and mismatch airline with data on a USB drive for use in confirming calibrated system performance, traceable to national standards. Test procedure is provided in the service manual.

85058V 45 MHz to 67 GHz 1.85 mm kit

Includes attenuators, match thru and mismatch thru with data on a USB drive for use in confirming calibrated system performance, traceable to national standards. Test procedure is provided in the service manual.

85059V 10 MHz to 110 GHz 1.0 mm kit

Includes a matched airline (85059-60048) and a mismatch airline (85059-60047), with data on a USB drive for use in confirming calibrated system performance traceable to national standards. Test procedure is provided in the service manual.

General Accessories

Spare drive¹

- N5242-60134 Windows 7 spare drive with mounting cradle for all N522x/3x/4xB models with 2.2 GHz CPU (version 7)

For information about spare drives for older PNA models, please refer to the configuration guide 5990-7745EN.

1. All spare drives use solid-state storage. For more information, refer to na.support.keysight.com/pna/hdnumbers.html.



General Accessories, continued

Probe

- 85024A high-frequency probe; provides high-impedance in-circuit test capability from 300 kHz to 3 GHz.

Power meters and sensors¹

Recommended for self support, adjustments and performance tests to verify proper instrument operation.

USB power sensors

- U848x Series USB thermocouple power sensors
- U2020 X-Series USB peak and average power sensors
- U2000 Series USB power sensors
- U2040 X-Series USB and LAN power sensors

Power meters

- P Series power meters (N1911A and N1912A) and all supported sensors
- EPM Series power meters (N1913A and N1914A) and all supported sensors
- EPM-P Series power meters (E4416A and E4417A) and all supported sensors
- E Series power meters (E4418 and E4419) and all supported sensors
- HP 437B / 438A power meters

Comb generators

Two are required for NVNA. Also requires separate power supply.

- U9391C 10 MHz to 26.5 GHz comb generator
- U9391F 10 MHz to 50 GHz comb generator
- U9391G 10 MHz to 67 GHz comb generator

Amplifiers

- 83006A power amplifier, 10 MHz to 26.5 GHz, 20 dB gain, power out: +18 dBm to 10 GHz or +16 dBm to 20 GHz or +14 dBm to 26.5 GHz
- 83017A power amplifier, 50 MHz to 26.5 GHz, 25 dB gain, power out: +20 dBm to 20 GHz, or +15 dBm to 26.5 GHz
- 83018A power amplifier, 2 to 26.5 GHz, 27 dB gain to 20 GHz or 23 dB to 26.5 GHz, power out: +24 dBm to 20 GHz or +21 dBm to 26.5 GHz
- 83020A power amplifier, 2 to 26.5 GHz, 30 dB gain to 20 GHz or 27 dB to 26.5 GHz, power out: +30 dBm to 20 GHz or +26 dBm to 26.5 GHz
- 83050A power amplifier, 2 to 50 GHz, 23 dB gain, power out: +20 dBm to 40 GHz or +17 dBm to 50 GHz
- 83051A power amplifier, 45 MHz to 50 GHz, 23 dB gain power out: +12 dBm to 45 GHz or +10 dBm to 50 GHz

Couplers

- 87300B coaxial coupler, 1 to 20 GHz, SMA (f), 10 dB coupling
- 87300C coaxial coupler, 1 to 26.5 GHz, 3.5 mm (f), 10 dB coupling
- 87301B coaxial coupler, 10 to 46 GHz, 2.92 mm (f), 10 dB coupling
- 87301D coaxial coupler, 1 to 40 GHz, 2.4 mm (f) or optional 2.92 mm (f), 13 dB coupling
- 87301E coaxial coupler, 2 to 50 GHz, 2.4 mm (f), 10 dB coupling
- 87310B 90° coaxial coupler, 1 to 18 GHz, SMA (f), 3 dB coupling

Equipment rack accessories

- E3663AC Rail kit (included with Option 1CM and 1CP)
- 1CM042A Rack mount flange kit, for use without handles (included with Option 1CM)
- 5063-1555 Rack mount flange kit with handles²
- 5063-1542 Front handle kit²
- 5063-1572 Rack mount flange kit, for use with classic handles (included with Option 1CP)²

Monitors

- Any VGA-compatible monitor can be connected directly to the rear panel. Monitors with other video interfaces (for example, HDMI or DisplayPort) require USB-based video adapters (must be supplied by the user). Touch-screen monitors are supported.

Interface cables

Choose the appropriate cables to connect each peripheral to the network analyzer.

- 10833A GPIB cable, 1.0 m (3.3 ft)
- 10833B GPIB cable, 2.0 m (6.6 ft)
- 10833D GPIB cable, 0.5 m (1.6 ft)
- 82357B GPIB to USB interface

1. For the latest guide to power meters and power sensors, refer to the Keysight web site: www.keysight.com/find/powermeters
 2. 5063-1555 is a complete rack mount kit with handles. N52xxB comes with ruggedized handles, which must be replaced with classic handles shipped with the rack mount kit. 5063-1542 is a pair of classic handles, and used with 5063-1572 for mounting N52xxB to a rack.



Evolving Since 1939

Our unique combination of hardware, software, services, and people can help you reach your next breakthrough. We are unlocking the future of technology.

From Hewlett-Packard to Agilent to Keysight.

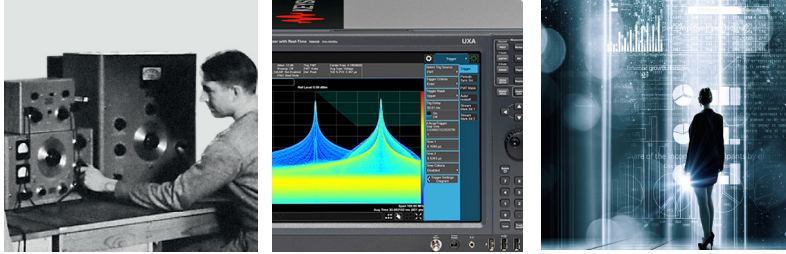

For more information on Keysight Technologies' products, applications or services, please contact your local Keysight office. The complete list is available at: www.keysight.com/find/contactus

Americas

Canada	(877) 894 4414
Brazil	55 11 3351 7010
Mexico	001 800 254 2440
United States	(800) 829 4444

Asia Pacific

Australia	1 800 629 485
China	800 810 0189
Hong Kong	800 938 693
India	1 800 11 2626
Japan	0120 (421) 345
Korea	080 769 0800
Malaysia	1 800 888 848
Singapore	1 800 375 8100
Taiwan	0800 047 866
Other AP Countries	(65) 6375 8100

Europe & Middle East

Austria	0800 001122
Belgium	0800 58580
Finland	0800 523252
France	0805 980333
Germany	0800 6270999
Ireland	1800 832700
Israel	1 809 343051
Italy	800 599100
Luxembourg	+32 800 58580
Netherlands	0800 0233200
Russia	8800 5009286
Spain	800 000154
Sweden	0200 882255
Switzerland	0800 805353
	Opt. 1 (DE)
	Opt. 2 (FR)
	Opt. 3 (IT)
United Kingdom	0800 0260637

For other unlisted countries: www.keysight.com/find/contactus (BP-9-7-17)

DEKRA Certified
ISO 9001 Quality Management System

www.keysight.com/go/quality
Keysight Technologies, Inc.
DEKRA Certified ISO 9001:2015
Quality Management System

This information is subject to change without notice.
© Keysight Technologies, 2012 - 2017
Published in USA, September 11, 2017
5992-1465EN
www.keysight.com

myKeysight

myKeysight

www.keysight.com/find/mykeysight

A personalized view into the information most relevant to you.

http://www.keysight.com/find/emt_product_registration

Register your products to get up-to-date product information and find warranty information.

KEYSIGHT SERVICES
Accelerate Technology Adoption.
Lower costs.

Keysight Services

www.keysight.com/find/service

Keysight Services can help from acquisition to renewal across your instrument's lifecycle. Our comprehensive service offerings—one-stop calibration, repair, asset management, technology refresh, consulting, training and more—helps you improve product quality and lower costs.



Keysight Assurance Plans

www.keysight.com/find/AssurancePlans

Up to ten years of protection and no budgetary surprises to ensure your instruments are operating to specification, so you can rely on accurate measurements.

Keysight Channel Partners

www.keysight.com/find/channelpartners

Get the best of both worlds: Keysight's measurement expertise and product breadth, combined with channel partner convenience.

www.keysight.com/find/pna