

digital design

the magazine of digital systems

A Feast Of Peripherals

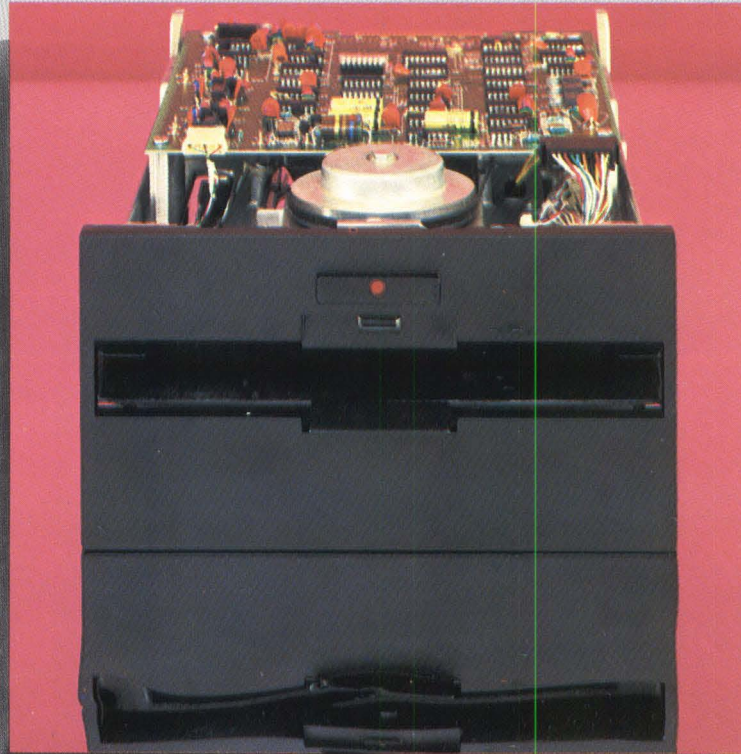



***Go with the winner-GSI-FDD 200.
Double-sided, double-track density, flexible disk drive.***

The winner in high quality, delivery and price. GSI's FDD 200 disk drive accommodates up to 25.6M bits using MFM or M²FM encoding techniques. Downward compatible with GSI's FDD 110 and available in the same package design, it is available for upgrading with minor system modifications. It is fully IBM compatible and will read and write IBM 3740 formatted diskettes. You also can daisy chain up to 4 drives.

Important features include: parallel ready lines plus unit select, separation of clock and data, Track "00" photo sensing, automatic diskette ejection and fail-safe interlock latch mechanism.

Go with the thousands of happy GSI winners. What have you got to lose?

Computer peripherals-second to none.

GSI THE WINNER

GENERAL SYSTEMS INTERNATIONAL, INCORPORATED

1440 Allec Street, Anaheim, CA 92805, (714) 956-7183, Telex 69-2488

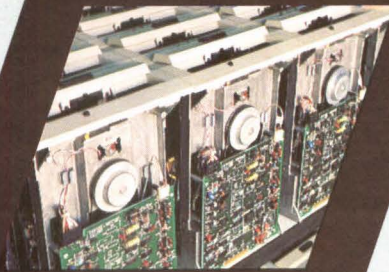

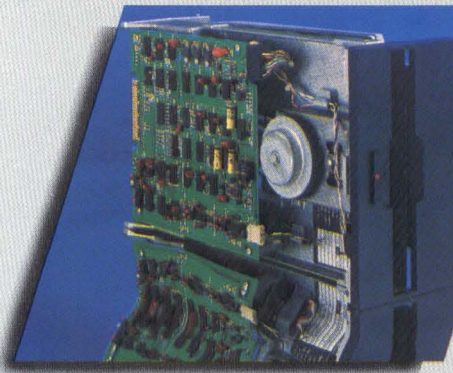

Flexible Disk Drive

GSI-FDD 110

A compact, random access, flexible disk drive for single or double density data storage.

It will accommodate up to 6.4M bits of data on one side of standard media using MFM or M²FM encoding techniques for double density applications. Single density storage in variable formats provides up to 3.2M bits of data. Fully IBM compatible the disk drive will read and write IBM 3740 formatted diskettes up to 1.9M bits. The high performance unit offers up to 4 drive daisy chain operation, parallel ready lines plus unit select, separation of clock and data and Track "00" photo sensing. It also has automatic diskette ejection and a fail safe interlock.

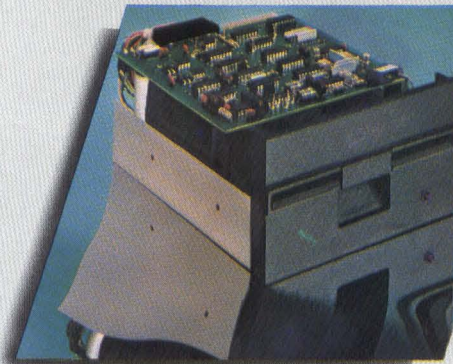

Flexible Mini-Disk Drive GSI-MDD 050

The GSI family of highly reliable small Mini-Disk Drives: MDD 050, 100K bytes; MDD 051, 200K bytes and the MDD 052, 465K bytes are designed to fit into many applications where conventional disk drives (GSI-FDD 110) are physically inappropriate and space is at a premium.

Low in cost, the MDD 050 Mini-Disk Drive utilizes a small flexible disk permanently housed in an envelope with the necessary apertures for drive spindle, head and sector hole access. Each envelope is 5¼" by 5¼" but otherwise is conceptually like the familiar IBM diskette.

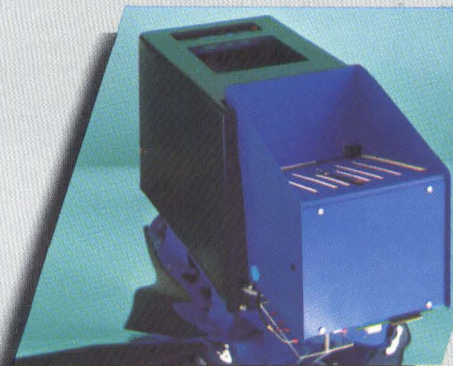

Horizontal Autoloader

GSI-H155

The Horizontal Autoloader automatically loads and unloads open or closed flap diskettes to and from a GSI-FDD 110 Flexible Disk Drive. Diskettes are loaded sequentially from the hopper. After processing in the diskette drive, the diskettes are electronically selected and stacked horizontally in either of its two bins. The bins are removable and suitable for general handling of diskettes.



Flexible Disk Drive Sub-Systems GSI-FDD 2100

Packaged horizontally into a 19" Retma rack mount chassis, the GSI-FDD 2100 series sub-systems provide single and dual drive capability. Included in the sub-system is the necessary power to drive two flexible disk drives and a customer supplied formatter. Input AC power is supplied from the host computer controller via a relay system included in the GSI-FDD 2100.

GSI-World leadership in computer

Multi-User/Multi-Task DOS COMMAND PERFORMANCE



muPro-80D Multi-User, Multi-Task Disk System

Software

- Concurrent Multiple Terminal Operation
- Multiple Task Real-Time Operating System
 - Supports up to 256 concurrent tasks
 - Provides 64 priority levels
- Program Overlay Capability
- Comprehensive File Management
 - List File Directory
 - Add, Delete, Rename, Append File
 - Run-Time file definition
- File Utilities: Copy File
 - Copy and Compress Disk
 - Format Disk
- I/O Device Characteristics transparent to user
- Concurrent Interrupt-Driven I/O
- Calendar Maintenance - Date, Time
- Supports BSAL-80, Linking loader and Text Editor
- Operating System Requires 16K Bytes

Hardware

- Dual Diskette Drive - 512K Bytes
- Soft Sektored - IBM 3740 compatible
- High Speed Seek - 76 track seek in 100mSec.
- Single Card Controller installs directly into muPro-80 chassis
- Double-Sided Recording - Optional
- Controller accomodates up to two dual drives (four diskettes), or four single drives
- Real Time Clock
- Write Protect
- Manual or Processor controlled diskette eject
- Data transfer via DMA
- Small Size - 4.6"H x 10.0"W x 21"D including power supply. 32 lbs.

Available in OEM and End User Configurations

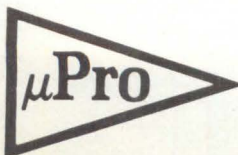

Manufacturers of Innovative OEM and End User Microcomputer Systems
muPro Inc. ■ 424 Oakmead Pkwy ■ Sunnyvale, CA 94086 ■ (408) 737-0500

What's in a name?

With the name Tandberg



you know it's gotta be good.

Now Tandberg's TDC 3000 Digital Cartridge Recorder communicates with every computer. Every computer.

Begin with the industry-proven Tandberg TDC 3000 Digital Cartridge Recorder. Add our new RS-232 I/O controller/interface. And you have a highly cost-effective recording system compatible with every computer.

There's a complete family of interfaces for the Tandberg TDC 3000. From the original design conceived by Tandberg of Norway, the \$150-million electronics firm that pioneered tape recorders internationally. The company that is to high quality electronic equipment what Rolls Royce is to automobiles. With a tradition of excellence that continues in a wide range of computer peripherals from Tandberg Data in the United States.

With total communications compatibility, the microprocessor-based RS-232 controller/interface from Tandberg Data is engineered according to EIA Standard RS-232-C, type D and E, and a "teletype-compatible current loop," recording in ANSI/ECMA/ISO-compatible format.

And from the substantial savings in line charges alone, the TDC 3000 with the RS-232 controller/interface will recoup its modest cost in a matter of months. It's hard to beat that kind of cost-effectiveness.

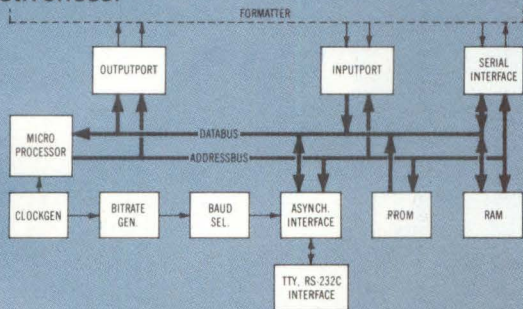

The Tandberg controller/interface is contained on one p.c. board which mounts inside the Recorder. Power is internal from the TDC 3000 built-in power supply. Two interface connectors are provided so that the Recorder can be connected both to a local I/O terminal (such as the Tandberg TDV 2100 Series CRT terminals) and a modem for remote operation.

Thirteen standard baud rates, 75-9600, are user selectable. Data buffers range from a minimum of 256 bytes up to 1024 bytes. The controller/interface responds to all ASCII command codes. Read and write speed is 30 ips and search speed 90 ips.

And for special communications requirements, the 6800 microprocessor allows the Tandberg controller/interface to be OEM-customer programmed.

Conceived in the rugged Norse heritage, the Tandberg TDC 3000 is no wilting lily when it comes to tough environments. Put it to work in subzero snow country or under a desert sun and don't worry about the bad vibes or emissions from nearby equip-

ment. The TDC 3000 is engineered to roll with environmental punches.

You might ask us about some of our more difficult applications. Modular construction of the TDC 3000 enables the user to configure a system to individual needs. Applications include minicomputer input/output, minicomputer peripheral storage, terminal peripheral storage, software distribution, data entry via keyboard, local data collection, data transmission, and text editing. And a few other things yet to be dreamed up.

Besides RS-232, Tandberg Data provides TDC 3000 interfaces for HP 21MX, PDP 11, Alpha LSI 2, and 8-bit parallel general purpose. All give up to 48K bits transfer rate.

Tandberg Data Inc.
4060 Morena Blvd.
San Diego, California 92117
(714) 270-3990

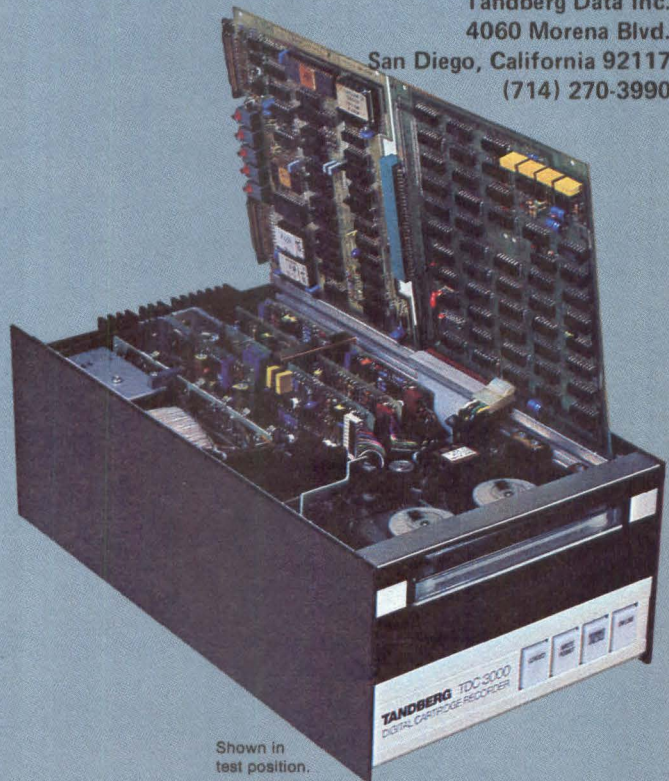

Shown in test position.

Mr. Bruce B. Greenfield, Vice President, Tandberg Data Inc.,
4060 Morena Blvd., San Diego, CA 92117

I'd like to know more about the RS-232 controller/interface for your TDC 3000. Please send me the RS-232 data sheet and have a Tandberg engineer give me a call to discuss my needs.

Name _____ Position _____

Company _____

Address _____

City _____ State _____ Zip _____

Phone _____

Computer/terminal type _____

TANDBERG



MICRO-TEC™

From the first independent commercial CRT terminal manufacturer comes the combination of quality, capabilities and low cost in a microprocessor controlled video display terminal.

*Stability
Age
Beauty*

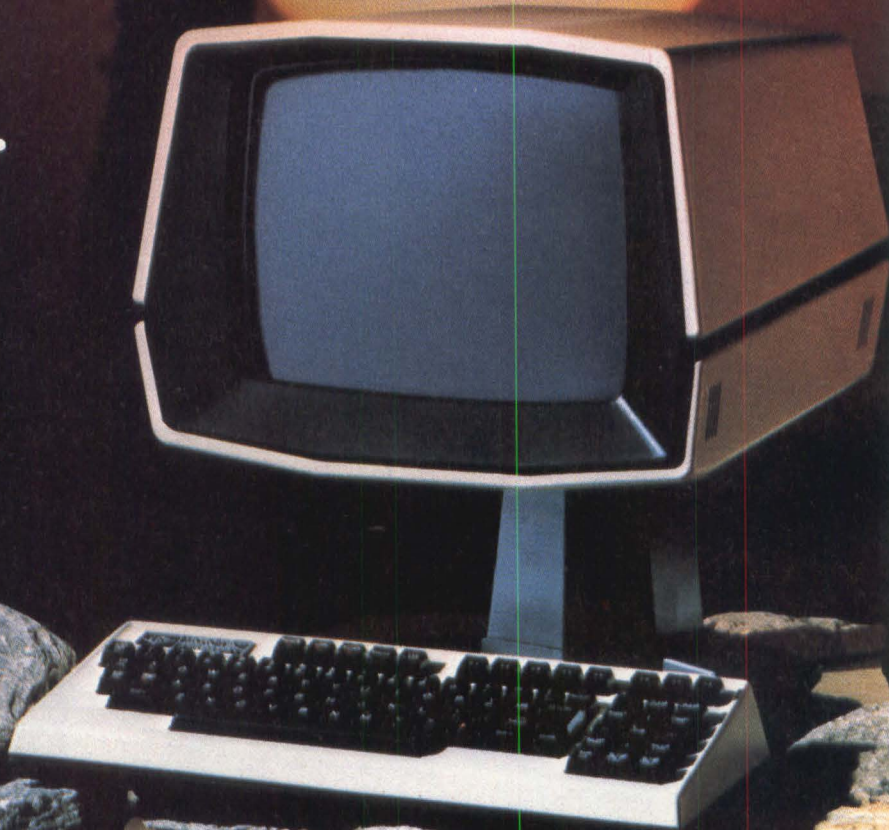

TEC, Incorporated

2727 N. FAIRVIEW AVENUE • TUCSON, ARIZONA USA 85705 • (602) 792-2230 • TWX 910-952-1377

AN EQUAL OPPORTUNITY EMPLOYER M/F, COMMITTED TO AFFIRMATIVE ACTION — A TEC INCORPORATED CORPORATE POLICY

CIRCLE 6

digital design

Volume 7 Number 5 June 1977

Features

20 Matching Magnetic Media with Modern Machines



Bob Katzive helps you understand, choose and get the most out of magnetic data storage media.

38 Digital Recording in Low Cost Transports

Clark E. Johnson, Jr., of Micro Communications shows you the inner workings of digital tape recording: system elements, signal processing techniques, encoding schemes and microprocessor application.

50 Cassette, Cartridge and Diskette Drives

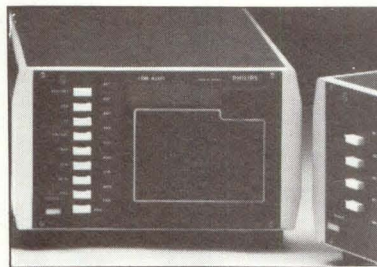

T. Ferrio, R. Keenan and R. Naden of Texas Instruments run down the basics of their comprehensive test system approach for bubble memories.

69 Magnetic Bubble Memory Testing

George King gives you the complete story on drives for your computer system. Also, a complete manufacturers' listing.

Departments

8 Letters

12 Technology Trends

Cards for Overseas System Design Low-Cost Graphics Display for OEMS Solid State Image Sensing Technology Solving Mini Incandescent Lamp Problems.
Digital Servo Control: Faster Starts, Stops.

80 Product News

91 Advertiser's Index

92 Viewpoint

Assembling the No-Language: Another Proposal by Karl V. Amatneek — The second part of a two part discussion of two annoyances associated with the use of microprocessors.

This month's cover, "A Feast of Peripherals", features the new Wango micro-floppy disk drive in the foreground. Other "entrees" include the Datum cassette drive and a 3M cartridge unit provided by AOC.

Next Month

The July issue of Digital Design emphasizes information display in digital systems. Edward Ross details the technology used in capturing analog information and converting it to digital data for visual presentation. Sharon Pellerin surveys graphic displays, and a report from Beckman Instruments shows you how to use planar gas discharge displays in multiplexed operation.

Published monthly by Benwill Publishing Corp., 167 Corey Rd., Brookline, MA 02146. Controlled Circulation postage paid at Long Prairie, MN. © Copyright 1977 Benwill Publishing Corp.

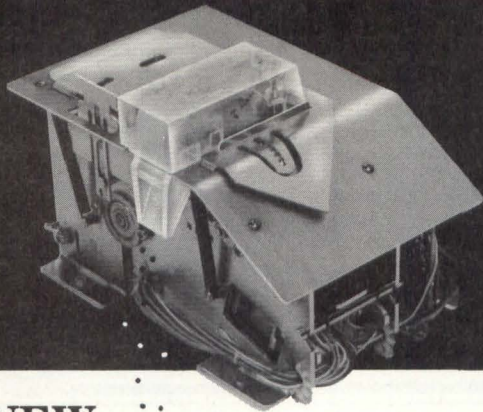

**NEW
FOR
OEM**

6110

PAPER TAPE PUNCH

**Lowest cost, highest reliability,
easiest to maintain in operation**

Epson's precision manufactured, miniature 6110 Paper Tape Punch mechanism offers high reliability and low unit cost to OEM.

Compare these value features:

- Long life steel punchblock warranted to process 500 9" reels MTBF.
- Simple design that allows compact size only 4" high, 4" wide and 6" long.
- Brushless motor for high reliability and low power consumption.
- Operation at 50 characters per second.
- Adjustable tape guide for 5, 6 and 8 channels.
- Easy to design control circuit.
- Price in OEM quantities less than \$200.00.

Complete factory parts, repair and customer training located at our Torrance main office.

Write or call for
complete information

EPSON

EPSON AMERICA, INC.

23844 Hawthorne Blvd., Torrance, CA 90505
(213) 378-2220

EPSON products are manufactured by SHINSHU SEIKI CO., LTD., Japan

CIRCLE 7

**digital
design**

staff

PUBLISHER	Yuri Spiro
EDITORIAL DIRECTOR	Harold G. Buchbinder
EDITORIAL BOARD	Dave Bandel Martin Himmelfarb Israel Katz Kirtland Olson
EDITOR	George King
ASSOCIATE EDITOR	William Belt
ASSISTANT EDITORS	Jeffry Beeler Sharon Pellerin Jeff Spier
STAFF ARTISTS	Mike Barisano Jane Higgins Mary Ann Parker J. Porter Irene Stawicki
PRODUCTION	E. Storm Merrie Buchbinder Joe Gillis Joe T. Ingram
COMPOSITION	Nancy Aldrich Jonna Yager
CIRCULATION	Samuel Freedenberg Regina Harrington
GENERAL ADMINISTRATION	Sarah Binder Marion Pearlman Charles Vigilante Joy Wallens

subscription policy

DIGITAL DESIGN is circulated only to qualified research, development and design engineers in all branches of industry, government institutions and universities. To obtain a complimentary subscription, request (on company letterhead) a qualification card from Circulation Director. For change of address; attach old address label from recent issue to new company letterhead or note telling us what your old address was; send this plus request for new qualification card to:

Circulation Director
DIGITAL DESIGN
167 Corey Road
Brookline, MA 02146

Subscription rates: Domestic subscriptions for non-qualified subscribers, groups, libraries or companies, \$25.00 per year. Foreign subscriptions, \$35.00 per year.

DIGITAL DESIGN solicits editorial material and articles from engineers and scientists. Contributors should submit their manuscripts in duplicate and typed with two spaces between lines. All illustrations should be clear; components on all schematics and line drawings should be labeled. The editors assume no responsibility for the safety or return of any unsolicited manuscripts.

BPA

CIRCULATION
OVER 42,000.

Published monthly by Benwill Publishing Corporation, Harold G. Buchbinder, Chairman of the Board; George Palken, President; Esther Shershow, Treasurer. Executive, Editorial and Subscription Offices, 167 Corey Rd., Brookline, MA 02146. Telephone (617) 232-5470.

CIRCLE 8 ►

The POLY 88 Microcomputer System

PolyMorphic Systems now offers the complete, assembled, personal computer system—the POLY 88 System 16. A full 16K system with high speed video display, alphanumeric keyboard, and cassette program storage. A BASIC software package providing the most advanced features available in the personal computing market. Features like PLOT and TIME, which utilize our video graphics and real-time clock. Others like VERIFY, so that you know your tape is good before you load another. Or input type-ahead so you can tell your program to run while the tape is still loading (it stores up to 64 characters of commands or question responses to be executed). All these plus a complete package of scientific functions, formatting options, and string capabilities. With the POLY 88 System 16 you can amaze your timesharing friends the very first night!

Polymorphic Systems 11K BASIC — Size: 11K bytes.

Scientific Functions: Sine, cosine, log, exponential, square root, random number, x to the y power.

Formatted Output • Multi-line Function Definition • String Manipulation and String Functions • Real-Time Clock • Point-Plotting on Video Display • Array dimensions limited by memory • Cassette Save and Load of Named Programs • Multiple Statements per Line • Renumber • Memory Load and Store • 8080 Input and Output • If Then Else • Input type-ahead.

Commands: RUN, LIST, SCR, CLEAR, REN, CONTINUE

Statements: LET, IF, THEN, ELSE, FOR, NEXT, GOTO, ON, EXIT, STOP, END, REM, READ, DATA, RESTORE, INPUT, GOSUB, RETURN, PRINT, POKE, OUT.

Built in Functions: FREE, ABS, SGN, INT, LEN, CHR\$, VAL, STR\$, ASC, SIN, COS, RND, LOG, TIME, WAIT, EXP, SQRT, CALL, PEEK, INP, PLOT.

Systems Available. The POLY 88 is available in either kit or assembled form. It is suggested that kits be attempted only by persons familiar with digital circuitry.

System 2: is a kit consisting of the POLY 88 chassis, CPU, video circuit card, and cassette interface. Requires keyboard, TV monitor, and cassette recorder for operation. \$735

System 16: consists of an assembled and tested System 2 with 16K of memory, keyboard, TV monitor, cassette recorder, 11K BASIC and Assembler on cassette tapes. \$2250.

System 0: The circuit cards an S-100 mainframe owner needs to be compatible with the POLY 88 software library. System 0 consists of the central processor card with monitor ROM, the video circuit card, and cassette interface, all in kit form. \$525.

Prices and specifications are subject to change without notice. California residents add 6% sales tax.

460 Ward Drive
Santa Barbara, Ca. 93111
(805) 967-2351

PolyMorphic
Systems



New 20 Column Full Alphanumeric Printer ... From Gulton

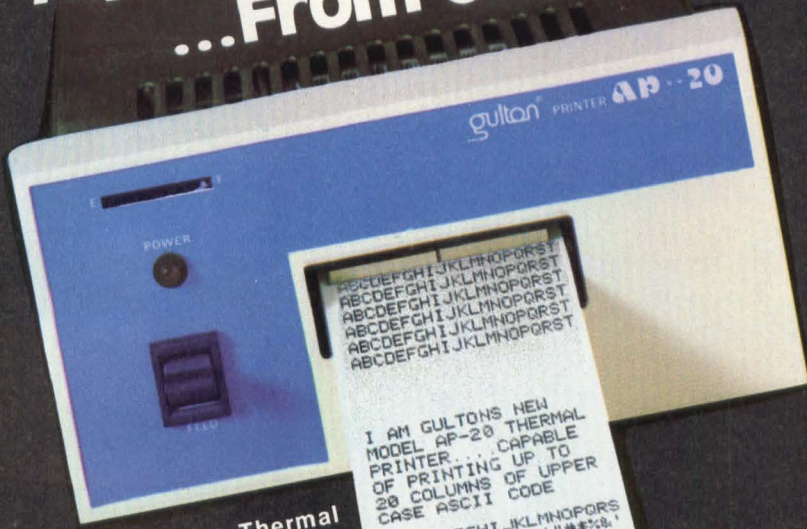

Featuring Quiet Thermal
Printing . . . 64 Characters/
ASCII Subset . . . 2.5 Line/
Sec. Print Rate . . . Panel
Mounting . . . Full Electronics
. . . Simple Parallel Inter-
face

Alphanumeric printers don't have to use complex mechanical devices as their print mechanisms, with their inherent clicking and banging.

Now, Gulton's AP-20 printer gives you a quiet, reliable, non-impact thermal printhead/print mechanism in a handsome unit complete with all electronics including power supply.

It's the most significant advance in printers yet . . . and at a price that's hard to resist.

Gulton offers a full line of alphanumeric, numeric and special character printers. Write or call for detailed catalog.

gulton[®]

Measurement & Control Systems Division
Gulton Industries Inc., East Greenwich, Rhode Island 02818
401-884-6800 • TWX 710-387-1500

letters

so that's why
they called it "owl"

• *Dear Editor:* I was pleased to find Perkin-Elmer's OWL-1200 Editing Terminal included in your product sampler (April, 1977). However, there is one important difference between the OWL-1200 and its contemporaries that was not mentioned. The OWL is the only editing terminal to have the Modified Data Tag capability as found in the IBM 3270-type systems.

For users concerned with rising transmission costs, this feature allows the terminal to return only modified data from its screen to the computer. Further savings are then realized when the computer software doesn't have to waste time validating entire screens to determine which fields have been altered.

MICHAEL D. ASHLEY
Manager, Marketing Communications
Perkin-Elmer Data Systems
Randolph, NJ 07801

crt terminal price correction

• *Dear Editor:* . . . we inadvertently furnished list price range for our keyboard display printer in lieu of keyboard display. . . (published in April 77 CRT Terminal Review charts, pp. 60-61). The list price range should read \$3755 to \$4540, dependent on display memory size and cabinetry. Prices are subject to a 10 or 20% functional discount.

I hope our oversight can be rectified.

TOM RACE
Teletype Corp.

Editor's note: Readers who may have been discouraged from sending for a catalog because of the significantly higher price listed can do so by circling 200 on the reader service card or write directly to Tom Race at Teletype Corp., 5555 Touhy Ave., Skokie, IL 60076.

CIRCLE 9

Another first for **ISS**

THE INDUSTRY'S MOST ADVANCED FIXED HEAD DRIVE

Announcing another in a long line of industry firsts for ISS—the ISS 550—the first fixed head disk drive to employ Winchester technology.

ISS is not only an innovator, but also one of the world's foremost manufacturers of OEM disk products, with all that means in the way of service back-up, spares, and technical assistance.

But at ISS, being first alone is not enough. The new ISS 550 has truly outstanding performance. Field upgradable capacity from 12.8 to 51.2 megabits. Average access time of 8.3 milliseconds. Sector formatting to meet individual requirements. And advanced technology that results in extremely low error rates.

Data transfer rate is 12MHz, and if that's too fast, you can slow it down with our data rate buffering feature.

But even high performance isn't everything. The new 550 is exceptionally reliable. It has only 25% as many

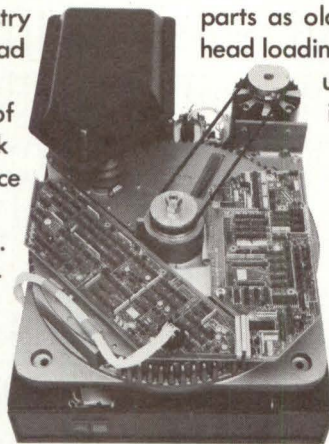

parts as older technology fixed head drives. There's no head loading mechanism. DC power supply is built in. The unit is self clocked. And the design incorporates interchangeable modular subassemblies for quick and easy maintenance.

All this performance and all this reliability go into a compact package that occupies just 14.5 inches of rack space.

But when all is said and done, the most significant statement we can make about the 550 is this: the price-performance ratio is twice as good as that of fixed head drives using older technology.

Get full details on this ISS first. ISS is an operating unit of Sperry Univac bringing technological leadership for the generations ahead. Write or call OEM Marketing, ISS, 10435 N. Tantau Avenue, Cupertino, California 95014, Telephone (408) 257-6220.

ISS 550. Twice the performance.

SPERRY  UNIVAC

SPERRY UNIVAC IS A DIVISION OF SPERRY RAND CORPORATION

CIRCLE 10

So much...

1. The basic architecture of the new SC/MP II which makes system design as easy as possible.
2. A series of hands-on training courses.
3. The software tools you'll need to create your own applications programs.
4. Low cost prototyping hardware.
5. Evaluation hardware.
6. A world-wide organization of field engineers to help if you need it.
7. A multi-million-dollar investment in test equipment that ensures you get a fully tested, reliable product.
8. Simple applications manuals that you can use like a cookbook.
9. A SC/MP II informational package, yours free for the asking—National Semiconductor, 2900 Semiconductor Drive, Santa Clara, Ca. 95051; (408) 737-5142.

 **National Semiconductor**
Microprocessors

for so little.

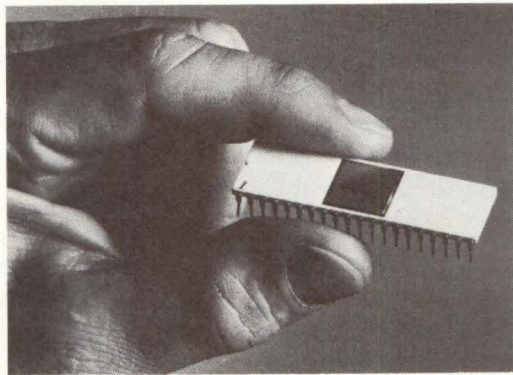

SC/MP II Microprocessor

Cards for overseas system design

Four new compatible cpu and memory application cards with standard Euro-card size and bus configuration allow fast, inexpensive construction of microprocessor systems destined for the European market. Developed by the Microcomputer Systems Group of National Semiconductor Corporation, the cards speed SC/MP processor design without time-consuming fabrication of special cards and racks.

The new family consists of the ISP-8C/100 (E) 8-bit SC/MP cpu card, one ISP-8C/004 (E) 4K by 8-bit random-access memory (RAM) card and the ISP-8C/004 B or P (E) 4K by 8-bit read-only memory (ROM) / programmable read-only memory (PROM) cards. All measure 160mm long by 100mm wide and have 64 edge connectors (32 each side) on 2.54mm centers.

For small applications, the ISP-8C/100 (E) serves as a stand-alone controller. It has 256 words of RAM and sockets for 512 words of ROM on the board as well as complete timing, control and power-up circuits. For larger applications, the cpu card has on-card decoding for separate address and data busses, allowing convenient memory expansion to 64K words and peripheral interfacing with compatible Eurocards.

The low-cost SC/MP microprocessor has separate serial-data input and outputs, two sense inputs, and three user-accessible control flag outputs. Address and data-bus-allocation logic facilitates multiprocessing and direct-memory access (DMA) application.

For effective programming, the SC/MP has a 46-word instruction set including both double-byte and single-byte commands. Memory-reference instructions use the program-counter relative, indexed or auto-indexed methods. Increment/decrement and transfer instructions are program-counter-relative or indexed while immediate addressing uses the second-byte contents as the operand for the operation. The SC/MP has 2 μ sec/microcycle instruction execution speed.

National Semiconductor memory application cards are size and bus com-

patible with the cpu card and with the Eurocard version of the SC/MP low-cost development system (LCDS). The ISP-8C/004 (E) RAM Eurocard provides 4K-by-8-bits of static read/write memory and the control circuits for address decoding and bidirectional data transmission over the busses.

The ISP-8C/004P (E) PROM Eurocard has 4K by 8-bits of unprogrammed PROM supplied by eight 512 by 8-bit chips (MM5204Q) while the ISP-004B (E) ROM/PROM Eurocard has sockets for up to eight 512 by 8-bits of erasable PROMS (MM520Q/MM5244) or pin compatible ROMs (MM5214). Both cards contain complete control circuits, module-select logic, and input/output buffers.

System software includes ROM resident assemblers, IMP-16 and PACE cross assemblers, FORTRAN cross assemblers, ROM resident NIBL — National's Tiny Industrial Basic Procedure

Language, and ROM resident loaders and debug programs.

Power supply requirements are +5V and -12V for the cpu and ROM/PROM cards, +5V for the RAM card. Mating connectors, compatible card cages, extender cards, wrapped-wire and interface cards are available from a number of sources.

The ISP-8C/100 (E) SC/MP cpu card is priced at \$250 each in unit quantities; \$218 each in quantities above 25. The ISP-8C/004 (E) RAM card is priced at \$225 each in unit quantities; \$219 each above 25. The ISP-8C/004 card with empty ROM/PROM sockets is \$125 each in unit quantities; \$119 above 25. The ISP-8C/004 (E) card, with 4K words of memory supplies, is \$525 each in unit quantities; \$457 each above 25. Delivery is stock to 15 days ARO. National Semiconductor Corp., 2900 Semiconductor Dr., Santa Clara, CA 95051.

Circle 151

Low-cost graphics display for OEM

Tektronix's new commitment to the OEM market is a low priced 19-inch storage-refresh graphics display in Original Equipment Manufacturing packaging. This display will be useful in computer aided design applications requiring high density graphics with moderate interactivity. Examples include printed circuit board layout in the electronics industry, IC mask design, or document preparation involving multi-font type such as page composition in the newspaper industry.

Available immediately, a completely stripped down but functionally operational version of the GMA101A will cost \$4775. The low price allows OEM's to offer high density graphics to their customers as part of their system for subsequent resale or lease.

The GMA101A features the economy of storage for the display elements that the user does not wish to edit such as display subpictures or graph axes, plus refresh capability for the

interactive placement of those elements prior to storage. Very complex pictures can be built-up piece by piece using a combination of refresh-storage to generate the picture. Store-refresh is the technique of writing on the phosphor without the image being stored, similar to a random refresh screen. Both stored and refresh information can be displayed simultaneously.

With an optional character/vector generator, it is possible to create a display with more than 3200 inches of stored vector and over 8500 alphanumeric characters. The GMA101A, offering the capability of displaying up to 600 inches of refreshed vectors has three modes of operation: store, store-refresh and non-store. In the non-store mode, the effect of storage flood guns is disabled. The user can write on the screen but the image is not stored. This is pure directed beam refresh capability. In the store mode, the image remains on the phosphor of the DVST

The concept and design of the Printronix 300 Impact Matrix Line Printer/Plotter offers you several remarkable cost/performance advantages.

Like dramatic savings in service costs from modular construction.

You might expect a precision 300 lpm line printer that produces print quality others can't match, and doubles as a plotter, to be a monster to service.

Actually, when compared to servicing other printers, it's easier and faster. Because of its modular design, the maximum MTTR is 30 minutes. With the exception of the main motor, all functional modules can be quickly removed without removing the shroud, as shown in the photos of the front cover raised and the back cover open. But that's only one reason why maintenance and service costs will be far lower than with other printers.

A Printronix 300 never requires character alignment or hammer flight time adjustment like other printers. Even the hammers and/or coils can be field replaced. And its mechanical simplicity extends MTBF so far that less servicing is required. That's why we've offered a one-year warranty from the beginning. You'll see why you'll have less downtime and fewer service calls. In short, a lower cost of ownership.

Printronix Inc., 17421 Derian Ave.,
Irvine, CA 92714. (714) 549-8272.

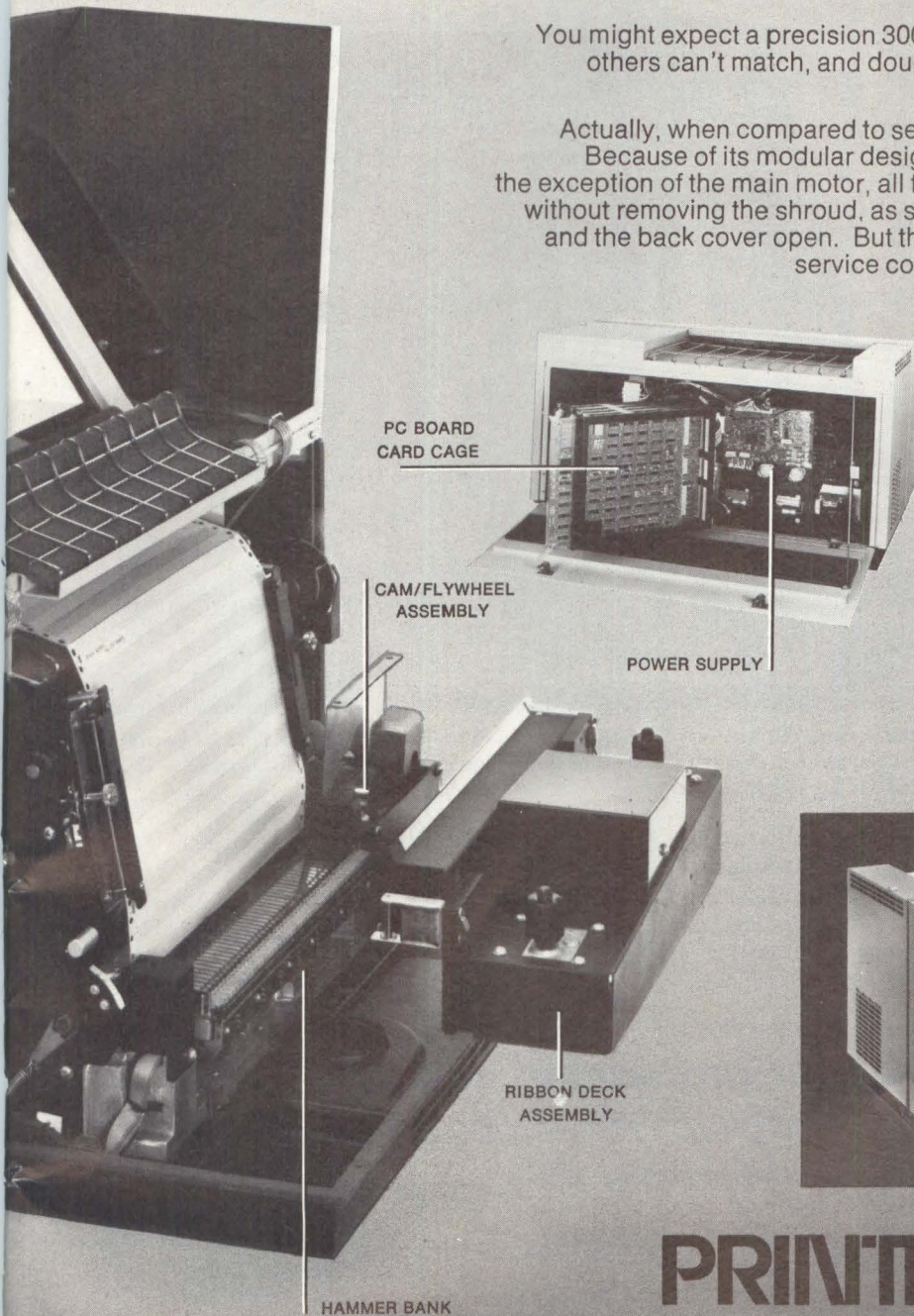

PRINTRONIX 300

It's your best buy!

screen instead of in a separate memory element requiring a separate memory buffer. In the store-refresh mode, the image is not stored but is free to move, change shape or be edited with stored information present.

The wireform construction of the chassis module is rugged and easy to use. Cables can be threaded throughout the unit and card cage. Additional modules can be added. The CRT module allows the display to be oriented either horizontally or vertically (page format)

and at viewing angles of either 90 degrees vertical or tilted back 15 degrees. A rack mounting is also available.

The circuit module provides an interconnect board with room for three additional plug-in boards as well as the standard high voltage and z-axis board, the storage board and the deflection amplifier board.

Except the X and Y inputs, the interface to the CMA101A is all digital and TTL compatible. Additional circuit board plug-ins provide space for

a Tektronix digital interface board, an ASCII interface board, a keyboard interface, a microprocessor and/or a custom vector generator.

Support options include portable display exercisers to aid the OEM in system design and interfacing requirements. Display exercisers can be used in conjunction with other service options in troubleshooting and calibrating the display in the field. Tektronix, Inc., P.O. Box 500, Beaverton, OR 97077. (503) 644-0161. **Circle 148**

Dynamic OEM semiconductor memory

Intel Memory Systems' in-1600 Dynamic Semiconductor Memory Systems, for OEM's requiring memory capacity in excess of 128K bytes, permits automatic or external refresh and comes as a basic card set or in a chassis.

As a basic card set, the in-1600 consists of Memory Unit Card (MU), Control Unit Card (CU), and Buffer Unit Card (BU). A single CU card can drive up to eight MU cards for a total capacity of 512K x 18 (1024K x 9 bits). Capacity expansion beyond 1024K bytes and word width expansion beyond 18 bits is possible by using BU cards to drive extra MU cards. Access time is 330 ns and cycle time, 500 ns. Modes of operation include Read, Write and Read/Modify/Write.

Automatic refresh in the in-1600 refreshes the whole system every 2 ms and operates on a cycle-stealing basis; 128 cycles are stolen every 2 ms. Since each cycle lasts only 500 ns, the throughput efficiency of the refresh mechanism is 96.8%. If automatic cycle-stealing is not permissible, the CU design allows external mode refresh control by the user. In applications where continuous memory access takes place, as with CRT displays, refresh can be made totally transparent to the user by ensuring that the seven lowest order address bits of each selected card are cycled at least once every 2 ms.

According to Gary Anderson, OEM marketing manager at the Intel division; "The new in-1600 memory system has a word width in excess of 22 bits or the total required capacity exceeds 512K bytes. Another recently announced Intel system, the in-3000, is best suited to handle medium capacity applications where bit count per word is not greater than 22."

The 64K words x 18 bits MU cards are priced from .17 to .26 cents per bit in quantities of 1 to 100. CU cards

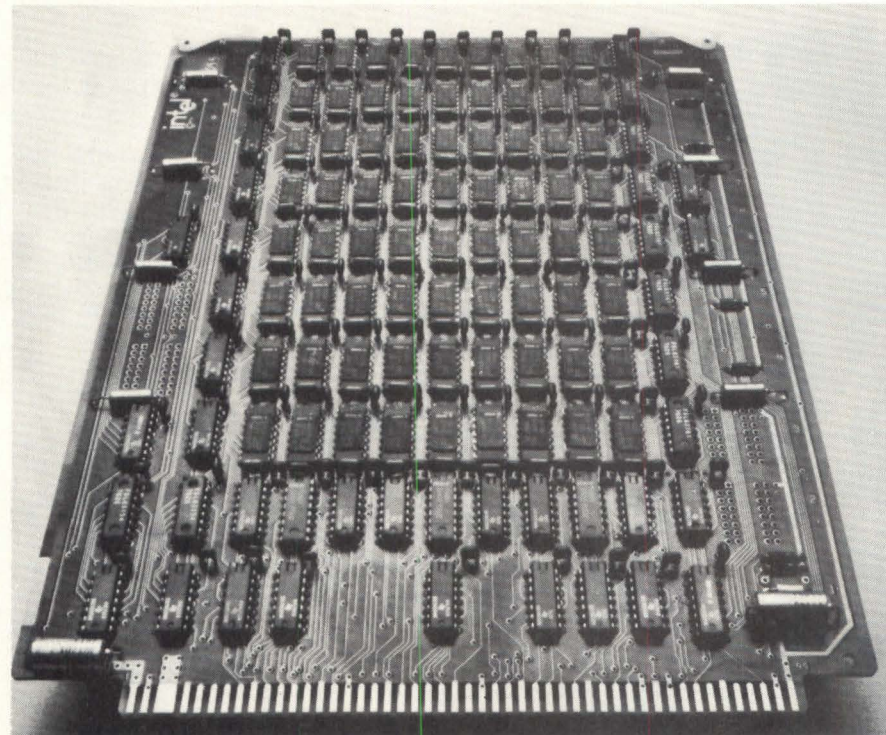

Intel Memory Systems' new in-1600 high-density memory system functions for general purpose applications as either a system or in individual cards with a storage capacity of 256K bytes per 8.2 x 10.5 inch card.

are \$300 and BU cards \$180. Total price for the in-Minichassis including power supplies and blower is \$1225. Price for the in-Unichassis varies, depending on the options selected. De-

livery is 90 to 120 days ARO. For more data contact Connie Magne, Intel Memory Systems, 1302 North Mathilda Ave., Sunnyvale, CA 94086. (408) 745-7120. **Circle 150**

Number-processing microcontroller cuts software development cost

The MM57109 pre-programmed microcontroller combines scientific calculator functions, test and branch capability, internal number storage and input/output functions on one chip. Basically a scientific calculator without a keyboard or display, it eliminates most of the time-consuming chores of

developing software and of grappling with the individual peculiarities of data transfer encountered when general purpose microprocessors are harnessed for these tasks. "The 57901 offers the best of both calculator and general purpose microprocessor worlds. The major advantages of the number cruncher are

If you make top-quality data terminals, here are four reasons to use Setchell Carlson CRT display modules in your system.

Reliability: Our data displays are outstanding solid-state designs with critically matched magnetics to optimize the performance levels and dependability demanded by your customers. We use the most advanced engineering and production techniques to assure consistency of performance. No data display is built with more deliberate attention to quality and reliability.

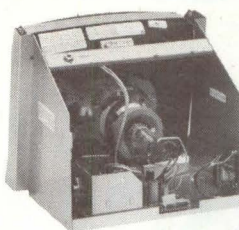

Delivery: We have been in the display electronics business long enough to know about rush orders. If you need it yesterday — we'll try to get it to you yesterday.

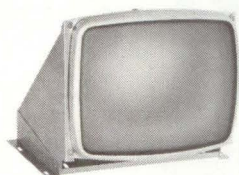

Experience: We've built thousands of displays for many of the major manufacturers in the country. Perhaps we already have a unit that would meet your requirements. With slight modifications. It would be less costly than starting from scratch. If you need a new, special package — we'll produce it for you, in the configuration you want, at minimal expense.

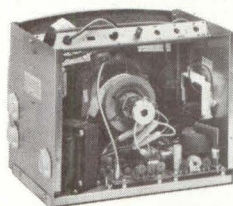

Cooperation: If you're developing a new data terminal, we will be glad to cooperate with your terminal design engineers in reviewing your exact specifications and developing the most economical display possible. And quickly! Whatever you need, we have the experience and talent to design it. And improve it.

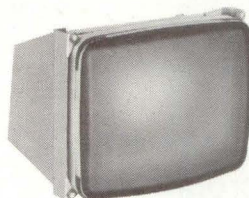

But don't take our word. See for yourself by contacting us today.

You'll come up with your own reasons for using Setchell Carlson CRT display modules.

SC ELECTRONICS, INC.
A SUBSIDIARY OF AUDIOTRONICS CORPORATION
530 5th AVE. N.W. NEW BRIGHTON, MN. 55112 (612) 633-3131

If you really compare design, specs, component quality, construction, price, delivery and guarantees, these are the power supplies you'll buy!

ADTECH POWER MICROCOMPUTER POWER SUPPLIES

Universal application: 115/230 VAC $\pm 10\%$
47-440 Hz (no derating for operation on 50 Hz).

Over 50,000 hours MTBF.

Hermetically sealed transistors and IC's

IC-zener protected against overvoltage.

Integrated circuit regulation and integrated Darlington TO-3 output stage provide much simpler circuitry, higher reliability

No overshoot on turn-on turn-off, or power failure.

Automatic foldback current limiting overload and short circuit protection

TO-3 can is mounted directly to frame to minimize wiring

Electrostatically shielded transformers reduce noise better than 4:1.

Tight line & load regulation; overload and short circuit protection.

Remote Sense standard on most Series.

U. L. Recognized glass-epoxy circuit board.

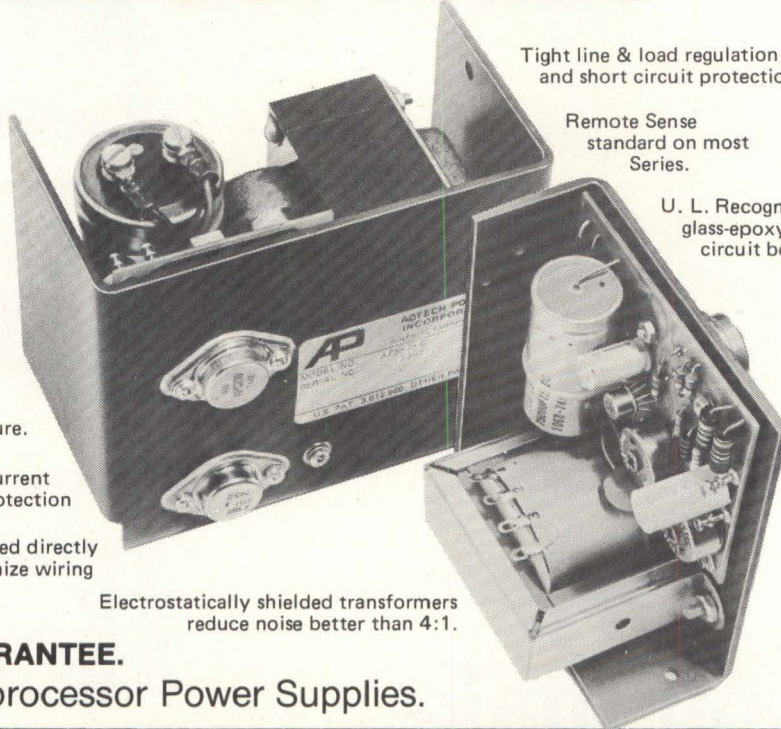

3 DAY DELIVERY... 6 YEAR GUARANTEE.
New Multiple Output Microprocessor Power Supplies.

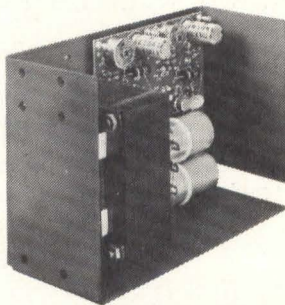

DUAL OUTPUT MICROPROCESSOR SERIES

U. L. Recognized. (File No. E58512)

MODEL NUMBER	RATING		QUANTITY PRICES							
	Vdc	Amps	1-4	5-9	10-24	25-49	50-99	100-249	250-499	
DAPS 5 8	± 5	0.8	43.00	41.95	40.70	39.80	38.00	36.80	33.00	
DAPS 9 12.5	± 9 to 12	0.5	43.00	41.95	40.70	39.80	38.00	35.80	33.00	
DAPS 12 7.5	± 12	0.75	43.00	41.95	40.70	39.80	38.00	35.80	33.00	
DAPS 15 6.0	± 15	0.60	43.00	41.95	40.70	39.80	38.00	35.80	33.00	
DAPS 5112.5	+5 -12	1.0 0.5	43.00	41.95	40.70	39.80	38.00	35.80	33.00	
DAPS 12 1.5	± 12	1.5	59.00	57.60	55.90	53.30	50.65	47.60	43.80	
DAPS 15 1.3	± 15	1.3	59.00	57.60	55.90	53.30	50.65	47.60	43.80	
DAPS 53121.5	+5 -12	3.0 1.5	59.00	57.60	55.90	53.30	50.65	47.60	43.80	

REGULATION: $\pm 0.05\%$ Line, $\pm 0.1\%$ Load. RIPPLE (PK/PK) 3mV.

DIMENSIONS: (Small unit) 4"x2.75"x4.87" (Large Unit) 7"x3.40"x4.87"

REQUEST BULLETIN DAPS - 976

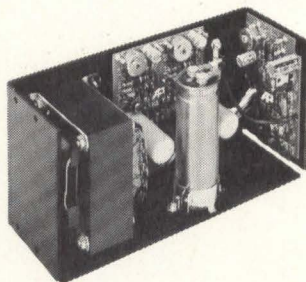

TRIPLE OUTPUT "TAPS" MICROPROCESSOR/GENERAL PURPOSE SERIES

MODEL NUMBER	RATING		QUANTITY PRICES						
	Vdc	Amps	1-4	5-9	10-24	25-49	50-99	100-249	250-499
TAPS 1	5V $\pm 9 - 12^*$	4.0 0.5	94.15	91.85	89.20	85.05	80.85	75.90	71.00
TAPS 2	5V $\pm 9 - 12^*$	6.0 1.0	107.00	104.80	101.80	96.85	92.10	89.00	87.50
TAPS 3	5V $\pm 9 - 12^*$	9.0 1.5	137.00	134.00	129.80	127.80	125.00	123.75	113.85
TAPS 4	5V $\pm 9 - 12^*$	12.0 3.0	163.00	159.00	154.45	151.50	149.00	148.00	147.00

* Also available with $\pm 12-15V$ output. Specify if desired.

REGULATION: $\pm 0.1\%$ Line, $\pm 0.1\%$ Load. RIPPLE (PK/PK): 5mV

DIMENSIONS: 8.62"x3.65"x4.87" to 15"x4.5"x4.87"

REQUEST BULLETIN TAPS - 377

Single Output Microcomputer Power Supplies.

15 TO 24 WATT "RED BARON" SERIES. SINGLE OUTPUT

* U. L. Recognized (File No. E58512)

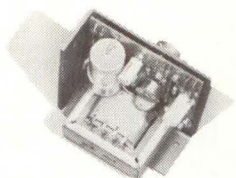

MODEL NUMBER	RATING		REGULATION		RIPPLE (PK/PK)	OVP MODEL SUFFIX	PRICES-ALL MODELS		
	Vdc	Amps	Line	Load			QTY	POWER SUPPLY	OVP UNIT
APS 5-3*	5	3	±0.05%	±0.1%	3mV	OV1-53	1-4	34.00	7.00
APS 6-2.5	6	2.5	±0.05%	±0.1%	3mV	OV1-63	5-9	33.15	6.90
APS 12-1.6*	12	1.6	±0.05%	±0.1%	3mV	OV1-122	10-24	32.20	6.70
APS 15-1.5*	15	1.5	±0.05%	±0.1%	3mV	OV1-152	25-49	30.70	6.40
APS 20-1	20	1.0	±0.05%	±0.1%	5mV	OV1-201	50-99	29.20	6.05
APS 24-1*	24	1.0	±0.05%	±0.1%	5mV	OV1-241	100-249	27.00	5.70
APS 28-0.8*	28	0.8	±0.05%	±0.1%	5mV	OV1-281	250-499	25.20	5.25

DIMENSIONS: 4" x 2.75" x 4.87" REQUEST BULLETIN APS-277

30 TO 60 WATT "GREEN HORNET" SERIES. SINGLE OUTPUT

† U. L. Recognized (File No. E58512)

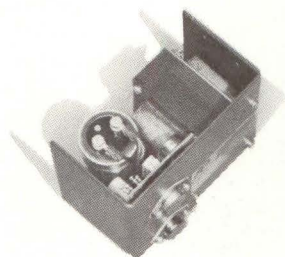

MODEL NUMBER	RATING		REGULATION		OVP MODEL SUFFIX	POWER SUPPLY PRICES			OVP PRICES
	Vdc	Amps	Line	Load		QTY	APS 48-1	ALL OTHERS	
APS 5-6†	5	6.0	±0.05%	±0.1%	OV2-56	1-4	68.00	55.00	15.00
APS 6-5	6	5.0	±0.05%	±0.1%	OV2-65	5-9	66.70	53.65	14.85
APS 12-4†	12	4.0	±0.05%	±0.1%	OV2-124	10-24	64.75	52.10	14.40
APS 15-3†	15	3.0	±0.05%	±0.1%	OV2-153	25-49	61.75	49.65	13.75
APS 20-2.4†	20	2.4	±0.05%	±0.1%	OV2-203	50-99	58.75	47.25	13.05
APS 24-2.2†	24	2.2	±0.05%	±0.1%	OV2-245	100-249	55.15	44.35	12.25
APS 28-2†	28	2.0	±0.05%	±0.1%	OV2-284	250-499	50.75	42.00	11.30
APS 48-1*	48	1.0	±0.05%	±0.1%	OV2-481	500-999	49.60	40.00	11.05

* RIPPLE: (PK/PK) 5mV. All others 3mV.

DIMENSIONS: 5.62"x3.40"x4.87" REQUEST BULLETIN APS-277

50 TO 120 WATT "BLACK BEAUTY" SERIES. SINGLE OUTPUT

5 Vdc @ 9 Amps to 28 Vdc @ 4 Amps. U. L. Recognized. (File No. E58512) *

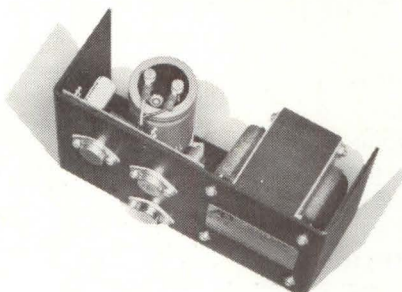

MODEL NUMBER	RATING		OVP MODEL SUFFIX	POWER SUPPLY PRICES				OVP PRICES	
	Vdc	Amps		QTY.	APS 5-9	APS 5-12	APS 5-18		ALL OTHERS
APS 5-9	5	9	OV2-510	1-4	71.00	85.00	108.00	75.20	15.00
APS 5-10*	5	10	OV2-510	5-9	68.75	82.95	104.50	73.40	14.85
APS 5-12	5	12	OV2-512	10-24	66.74	80.55	101.45	71.30	14.40
APS 5-18	5	18	OV2-518	25-49	63.90	76.80	96.70	67.95	13.75
APS 12-7*	12	7	OV2-127	50-99	61.05	73.00	91.95	64.60	13.05
APS 15-6*	15	6	OV2-156	100-249	57.30	68.55	86.35	60.65	12.25
APS 24-5*	24	5	OV2-245	250-499	52.75	65.00	79.45	55.80	11.30
APS 28-4*	28	4	OV2-284	500-999	51.60	57.90	77.70	54.60	11.05

REGULATION: Line ±0.05% Load ±0.1%. RIPPLE (PK/PK): 3mV on 5, 12, 15V models, 5mV on 24, 28V.

DIMENSIONS: 9"x3.65"x4.87"

APS 5-18 DIMENSIONS: 14"x3.65"x4.87" REQUEST BULLETIN APS-277

125 TO 250 WATT "BLUE MAX" SERIES. SINGLE OUTPUT

5 Vdc @ 25 Amps to 28 Vdc @ 9 Amps.

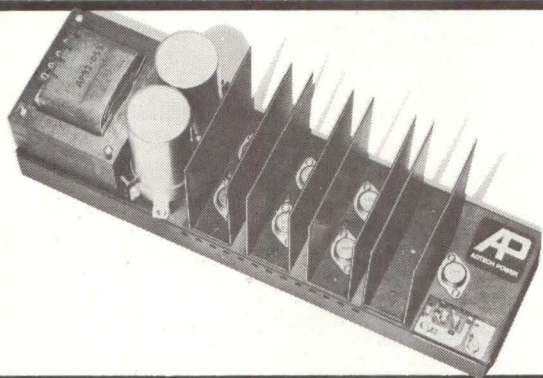

MODEL NUMBER	RATING		REGULATION		OVP MODEL SUFFIX	POWER SUPPLY PRICES			OVP PRICES
	Vdc	Amps	Line	Load		QTY.	APS 5-30	ALL OTHERS	
APS 5-25	5	25	±0.05%	±0.01%	OV3-525	1-4	163.00	158.00	25.00
APS 5-30	5	30	±0.05%	±0.01%	OV3-530	5-9	159.25	154.40	24.50
APS 6-22	6	22	±0.05%	±0.01%	OV3-622	10-24	154.65	149.95	24.25
APS 12-17	12	17	±0.05%	±0.01%	OV3-1217	25-49	147.45	142.95	23.15
APS 15-15	15	15	±0.05%	±0.01%	OV3-1515	50-99	140.20	135.90	22.00
APS 20-11	20	11	±0.05%	±0.01%	OV3-2011	100-249	131.65	127.60	20.65
APS 24-10	24	10	±0.05%	±0.01%	OV3-2410	250-499	121.10	117.40	19.00
APS 28-9	28	9	±0.05%	±0.01%	OV3-289	500-999	118.50	114.85	18.60

RIPPLE (PK/PK): 3mV on 5,6,12,15V models, 5mV on 20,24,28V models.

DIMENSIONS: 16.72"x4.87"x6.60" Max. APS 5-30 only. All others 16.72"x4.87"x5.75".

REQUEST BULLETIN APS-277

CALL OUR ENGINEERING SALES OFFICE IN YOUR AREA FOR APPLICATION ENGINEERING ASSISTANCE

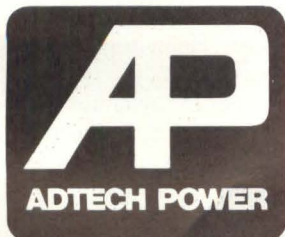

Alabama, Huntsville (205) 536-1941
 Arizona, Phoenix (602) 946-9860
 California, Orange Co. (714) 523-1223
 San Diego (714) 278-2150
 Los Angeles (213) 870-9191
 San Francisco (408) 247-9891
 Colorado, Denver (303) 773-2830
 Connecticut, North Haven (203) 239-2507
 Florida, Satellite Beach (305) 773-4700
 Ft. Lauderdale (305) 581-6611
 St. Petersburg/Tampa (813) 360-1484
 Georgia, Atlanta (404) 252-5360

Hawaii, Honolulu (808) 941-1574
 Illinois, Chicago (312) 298-4830
 Indiana, Indianapolis (317) 251-2757
 Kansas, Kansas City (913) 649-4000
 Massachusetts, Boston (617) 449-3034
 Michigan, Detroit (313) 576-4705
 Minnesota, Minneapolis (612) 854-4270
 Missouri, St. Louis (314) 997-1515
 New Mexico, Albuquerque (505) 265-2202
 Las Cruces (505) 524-0126
 New York, Albany (518) 456-6667
 Buffalo (716) 632-7880

New York, New York (516) 487-3966
 Rochester (716) 482-3000
 Syracuse (315) 637-9383
 North Carolina, Winston-Salem (919) 725-6196
 Ohio, Dayton (513) 434-8808
 Pennsylvania, Philadelphia (215) 825-9515
 Pittsburgh (412) 961-0414
 Texas, Dallas (214) 387-2489
 Houston (713) 665-0991
 Washington D.C., (202) 363-9417
 Wisconsin, Milwaukee (414) 421-2300
 Eastern Canada, Montreal (514) 363-5120

ADTECH POWER Inc., 1621 South Sinclair Street, Anaheim, California 92806 (714) 634-9211

zero software development cost, and off-shelf availability," said Orville Baker, National Semiconductor product marketing manager.

The microcontroller can be used by itself in many control applications, such as machine process controllers, navigation systems and measurement and test equipment, where it generally requires only an external program counter and program source. Alternatively, it can function as a subsidiary unit on the data bus of a micro- or minicomputer system.

The MN57109 is the latest of National's Controller Oriented Processor Series of devices that fill the gap between standard microprocessors and custom LSI circuits, delivering more sophisticated functions and programming capabilities than standard chips. The unit is completely pre-programmed for immediate availability. Because it has a single clock, low power operation, single 9 Volt power supply and separate digit input, output and address

bus, the MM57109 easily interfaces with most input and output functions.

The chip can accept a series of binary coded decimal digits with a single input instruction, an asynchronous digit input or a single bit input. The chip has a preprogrammed instruction set similar to the ones in scientific calculators which use Reverse Polish Notation, so the software required to perform trigonometric, logarithmic, and exponential operations directly is built into the device. Programming is done in a language similar to calculator keyboard level language.

The internal data word of the device is like a calculator's, containing twelve digits, each digit consisting of four bits. Eight digits are used for the mantissa, two digits are used for the exponents, one digit for the sign and exponent, and lastly, one serves as guard digit to improve accuracy of function. All functions are accurate to eight digits. When used as a stand-alone processor, it receives its instructions from an ex-

ternal source (PROM) and program counter in six-bit form. The device is TTL compatible and can be operated from power supplies of +5 Volts and -4 Volts. The signal inputs are designed to respond to TTL logic levels, except for HOLD and POR.

Circle 188

Solid State Image Sensing Technology

RETICON Corporation, of Sunnyvale, California, has announced a new family of solid state image sensors. Designated the CCPD series, for Charge Coupled PhotoDiode, these devices combine the best features of both CCD and RETICON's long-established photodiode array technology.

While the actual sensing aperture is made up of a series of diffused photodiodes, interdigitated on 16μ centers, the readout is provided by CCD analog

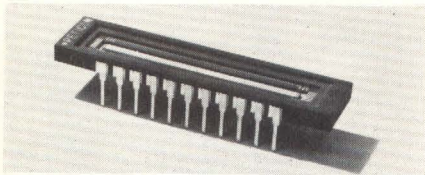

shift registers. The photogenerated charge integrated on the odd and even elements of this photodiode structure are side dumped upon application of a transfer pulse into two CCD registers which then transfer the charge to an on-chip output charge detection circuit. Since this output has a very small capacitance, the output signal voltage and thus the signal to noise ratio are very high. The outputs of the two CCD registers are then multiplexed off-chip to obtain a full-wave "boxcar" type sampled and held video output.

The circuit arrangement used also substantially reduces fixed pattern

noise. This arrangement thus offers the low capacitance, low noise output inherent in CCDs. Yet it offers the higher quantum efficiency, freedom from blooming and uniform response of photodiode arrays. The diffused photodiodes provide a spectrally smooth full silicon response unaffected by the polycrystalline layer covering the sensing area in CCDs. The so-called "transparent electrode" of a CCD absorbs strongly at short wavelengths as well as acting as an interference filter. It thus reduces quantum efficiency, particularly in the blue, and causes strong interference effects throughout the visible spectrum.

The diffused photodiodes of the CCPD device, on the other hand, are completely free of these effects thus making them particularly useful in OCR and facsimile applications. CCPD devices also exhibit current characteristics at least an order of magnitude below currently available CCDs thus making them usable at lower clock rates corresponding to integration times as long as 40 msec at room temperature.

Commercial introduction of the new device family is expected in the second quarter of 1977 at prices competitive with available CCDs and photodiode arrays. RETICON Corp., 910 Benicia Ave., Sunnyvale, CA 94086.

Mini Incandescent Lamp Problems?

could be fretting corrosion

Recent specifications on the use of lighted switches and annunciators require that they be subjected to random vibration and so called "gunfire vibration" environmental testing, as well as the normal sinusoidal vibration testing previously specified. To minimize lamp filament damage during such testing, many users have specified the use of the more rugged five-volt subminiature incandescent lamps, rather than the more commonly used 28-volt lamps, for aircraft applications.

In random vibration testing of products utilizing these five-volt lamps, engineers at Korry manufacturing began to notice "flickering" (or intermittent contact) after a few minutes of vibration. Once such flickering began to occur, it persisted after completion of vibration testing. Removal of the lamp and abrasion of the lamp solder spot contact would eliminate the problem for a period of time, but the flickering condition would recur with subsequent vibration. At times, the lamp would permanently extinguish until the lens cap was pushed or jiggled.

Last month, James W. Amis, Jr., Korry's chief engineer, reported to SAE's A-20A subcommittee on aircraft and lighting that this problem was first noted during random vibration testing on electronic equipment produced for the B-1 airplane by Boeing Aerospace Company. Korry Manufacturing Co. and Boeing Company personnel first investigated design modifications to the switchlight lamp contacting element. The parameters examined were contact interface geometry, contact plating and lamp contact force. All modifications to the lamp contacting element produced negative results.

Modifications to the lamps themselves proved effective. Initially this approach was examined by electroplating the lamp solder spot with hard nickel plate. Because of concern for

the durability of such a procedure due to the softness of the underlying solder, Amis, arranged for the purchase of a special lamp configuration with a plated brass disk rather than the solder spot for the lamp center contact. This configuration performed satisfactorily as a long term solution.

A search of technical literature revealed that the problem was a condition termed "fretting corrosion", first recognized and identified in 1922. More recently, connector manufacturers, in searching for a reliable plating system to replace gold in electrical contacts, have given considerable attention to this condition.

Fretting corrosion is described as a form of accelerated atmospheric oxidation which occurs at the interface of contact materials undergoing slight, cyclic relative motion. In electric contacts involving non-noble metals, fretting action can cause a rapid increase in contact resistance, proceeding to virtually open circuits in a matter of minutes.

In normally static contacts we can visualize the contact interface as consisting of one or more contact asperities at which metal-to-metal contact has been established. With non-noble metals, it is believed that these contacts are clean-metal junctions formed by mechanical break-through of thin oxide films which form on the exposed surface. With relative motion between the contacts, the original contacts are broken and new ones established constantly. The old contact areas quickly oxidize. With cyclic relative motions of limited amplitude, so that the motion is ineffective in clearing away the wear debris and accumulated oxides, a highly localized, thick, insulating layer is formed in the contact interface.

A variety of synthetic and natural oils applied to the contact interface can prevent or minimize the effect of fretting corrosion by preventing exposure of the clean metal to air and subsequent oxidation of the contact interface. Korry Manufacturing Co. has not pursued this technique, Amis, reported, because they felt high operating temperatures of the lamp and the severe atmospheric environments to which their products are exposed would reduce the effectiveness of such a procedure. In addition they found lubricants to be an attractive element for dust and other contaminants in their products and are traditionally not employed.

As a result of their experience with fretting corrosion, Korry Manufacturing Co. discussed the problem with sup-

pliers of miniature and subminiature incandescent lamps. They presently procure lamps containing a nickel-plated brass center contact for five-volt service applications, such as are available from Chicago Miniature Lamp Co. at a moderate premium over standard five-volt devices. They are specified by appending the number "-297" to the normal lamp part number.

Digital servo control: faster starts, stops

A microprocessor programmable for velocity, acceleration and position improves the velocity profile of servo control systems. The phase lock speed control regulates the velocity of the motor, making it capable of continuously generating a smooth vector at high speeds in multi-axis systems. Applications of the digital servo control system include machine tool controls, phototypesetting systems, optical scanners and high speed plotters.

The system can perform these critical in-progress functions without reprogramming: HOLD/RESTART, allowing the program to be interrupted

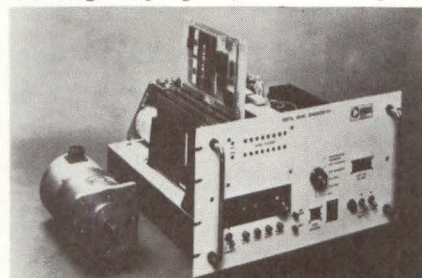

Servo system incorporates microprocessor for programmable position, velocity and acceleration control.

and restarted on command, and STOP/ERASE/ISSUE NEW COMMAND/RESTART. The microprocessor contains a memory that allows the computer to be diverted to other applications once the system has received a command.

Easily reprogrammed, the system fits applications that require regulated accelerations and velocity to prevent mechanical resonance problems, or to meet accurate rate specifications.

Parallel 8-bit bytes provide input with three bytes for position, one byte for acceleration and one byte for velocity. Serial pulse trains provide programmed control for both acceleration and deceleration. The microprocessor system requires ± 15 VDC @ 150 ma and + 5 VDC @ 1.0A. **Circle 189**

Now! Adtech Power Supplies are built in France for fast delivery anywhere in Europe!

The standard OEM power supplies that are the best buy in the United States are now manufactured and sold in Europe by SOPHIA, the wholly-owned subsidiary of Adtech Power, Inc., Anaheim, California, U.S.A.

For product literature, prices and application, contact:
SOPHIA, 46 BD. Roger Salengro
78200 Mantes La Ville, France,
Telephone: 4775301 +

See the Adtech Product listing on the preceding two pages.

SOPHIA

WHOLLY OWNED SUBSIDIARY OF
ADTECH POWER, INC., ANAHEIM,
CALIFORNIA 92806, USA.

CIRCLE 14

Matching Magnetic Media With Modern Machines

by Bob Katzive

When Homer, the poet, was writing the Iliad and the Odyssey, he needed a large number of scrolls. Realizing he could get a quantity discount, he put the order out to bid and received the quotes. The higher one was from a well-known reliable supplier, Hyqualities. The other, lower, bid was from a new supplier, Mediocrates. Homer, being blind and not able to tell the difference, selected the lower priced product which is why much of his work has been lost: An early example of valuable data loss due to a poor choice of storage media.



Since that time, data storage media have progressed from reed fibers to sophisticated magnetic films, but the problem of selection remains to haunt the unwary. Some of the major considerations are:

- What makes "good" magnetic media? What can you expect?
- How good does "good" have to be?
- How do you maximize media performance?
- How do you get maximum media life?
- How do you care for magnetic media — and what happens if you don't?

what does magnetic media do?

All magnetic storage media perform the following functions to some degree:

1. Provide a magnetic storage element.
2. Control the location of the magnetic element relative to the read/write head(s).
3. Protect the magnetic element when not in actual head contact.
4. Maintain data integrity over a period of time and under variable environments.

These functions are applicable to cassettes, disks, cartridges and tape and quality/performance judgements can be made between products depending upon how well they perform in these four areas.

The choice of a drive/media subsystem for a given application should not be made without considering quantitative requirements in the area listed above, as well as other system factors such as access time, total storage required and cost.

avoid confusion in specification

Because of the proliferation of media types, there is a tendency to call anything that isn't a reel of ½ inch tape or a magnetic card a "cassette." Even in recent publications, some editors and authors have erred in labeling the diskette, the new 5¼ inch diskette, the ¼ inch diskette, the ¼ inch cartridge, the 0.150 inch cartridge and other products as "cassettes." Such careless nomenclature does no one any good and guarantees a surprise or a delay when placing orders for magnetic media. Fig 1 illustrates commonly used media and their proper names.

the magnetic storage element

Storage capacity is provided by a thin magnetic coating put down upon some supporting structure that is usually a stable, inert, non-magnetic film or a rigid non-magnetic metallic substrate or surface. Both the magnetic coating and the substrate, or base film, must be carefully controlled to provide consistent performance. Because transports/drives are capable of operating over a limited range of adjustments, it is an advantage to employ the most consistent media available, thus minimizing the range of adjustments required.

The actual magnetic performance is controlled by the type of magnetic particle used and the amount of it coated on as the magnetic film. For a given percentage oxide composition, thicker magnetic films will produce more readback output. Most suppliers will specify output referenced to the NBS standard tape. The typical range is +10%, -25% of a specified

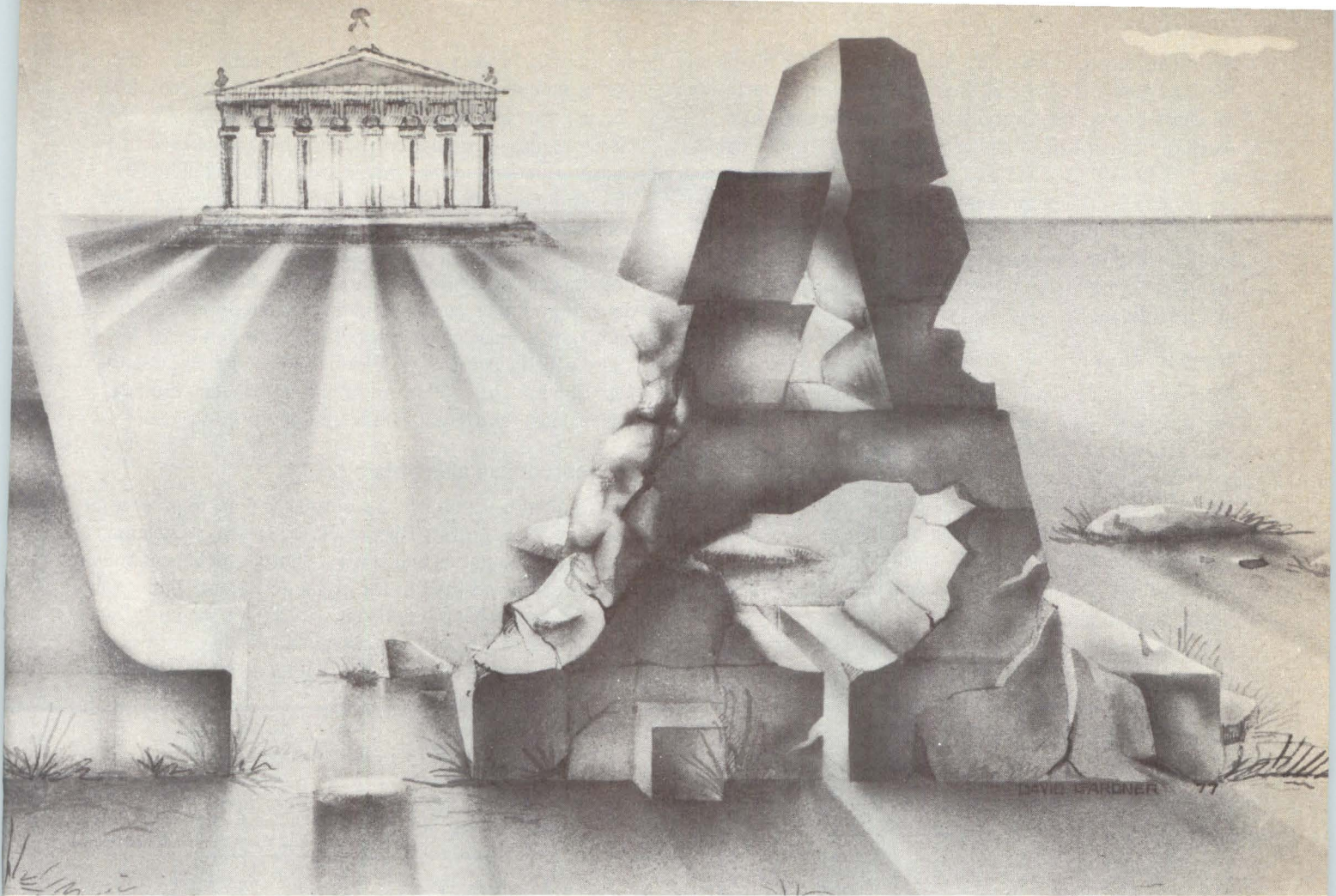

level which is in itself pegged to the NBS standard. For instance, a given tape may be characterized as having an output level of 110%, +10%, - 25%, related to the NBS benchmark. Some suppliers can consistently supply magnetic media with a consistency of $\pm 5\%$ of a given level. This quality is obviously an advantage; since it minimizes the possibility of failures due to component value shifts combining with worst case media tolerances.

The magnetic coating is typically a complex mixture of magnetic particles, polymeric binder for adherence to the base film, carbon particles to provide conductivity to prevent static charge buildup, and lubricants to reduce abrasion and extend media surface and head life. The exact types of substance used and their degree of use are generally closely held secrets among manufacturers; no two magnetic films are precisely the same. There are also batch to batch variations even among magnetic media from the same manufacturer, although the best will not vary more than a few percent in performance regardless of the parameter being measured.

Almost all major media suppliers have the ability to produce non-abrasive media, but simple tests will show vast differences in the following parameters:

- Longevity under actual use
- Adhesion of oxide to base film
- Resistance to solvents
- Transmissivity to visible and infra-red radiation (used to detect "media in place" by drive)
- Electrical conductivity
- Magnetic characteristics

One word of warning: magnetic media designed for audio use generally are inferior in overall oxide coating quality to those designed for digital use in a digital environment. Furthermore, the magnetic and frequency characteristics are notably different. While it is not correct to state that a product designed for audio service will always fail in a digital system, the probability of failures is higher because the design margin is less. Examples: Audio tape typically has poor transmissivity control because audio systems do not use photosensors to detect the presence of the media. Digital media have a more non-linear B-H loop and do not require extended high frequency response for most applications. Similarly, audio tape frequently omits the carbon particles that provide the controlled conductivity necessary to provide a discharge path for static charges built up by high speed tape motion. Of course, there is no chance of confusion with magnetic media other than cassettes; they are not used in both audio and digital applications.

In the case of diskettes, key factors to be evaluated are: amplitude of signal; modulation of constant write amplitude upon readback; grass (random noise); overwrite — (ability to write over previously recorded data); dropouts and drop ins; abrasivity; durability and resolution.

All are significant; some will be more so than others. Resolution is especially important for double density drives. There is no diskette made by any manufacturer which is better in all parameters than any other diskette, though, so your selection must be made on what is important in your given application. It is also worth noting that the results of compara-

tive media tests may be dependent upon the exact design of the drives used, the state of their maintenance, temperature/humidity conditions, airborne contaminants, and which batch of magnetic material happened to be tested. There is much to be said for testing to the point of proving that media are reliable for the purpose intended and stopping there, unless you know that some particular characteristic, if superior, results in a unique performance advantage such as lower maintenance costs that optimizes the trade-off between cost and performance.

the base film

Most media use a plastic base film, usually specified as oriented polyethylene terephthalate. This class of compound includes such products as Mylar™ which is probably the most commonly used film in the U.S., and Celanar™ and Melinex™. However, others are used, especially in products made overseas. The base can be important if the tensile strength varies. While tapes are usually oriented in the direction of tape motion, diskettes generally use a film with equal strength in all directions.

If the base film is not properly handled during manufacture, coating and slitting, the resultant products may have

degraded lifetimes. Proper choice of films and close inspection of incoming film shipments reduce this risk considerably. Because the base film provides much of the control of the magnetic film location relative to the read/write head of a transport, it is important that it be capable of holding its dimensions and strength under conditions of varying stress temperature, and humidity — critical factors as recording densities increase. One of the major factors impeding higher diskette capacity is the tendency of base films to change dimensions under varying humidity. Similarly, the upper temperature range of most base films is limited to 70°C, above which a permanent deformation occurs. Because the base film is a critical element of magnetic media, drive designers must take its capabilities and limits into account.

the mechanical elements

The film sandwich on which recording is done requires some structure to support it. This structure provides protection against contamination and contact damage, and also frequently controls the position of the magnetic surface relative to the head. While mechanical design is critical, it is the most frequently overlooked consideration in media design. For instance, the materials used in the shell of a cassette determine

ANATOMY OF A CASSETTE

To develop the vocabulary necessary to have a dialog with knowledgeable cassette users, the following series of annotated drawings will be helpful.

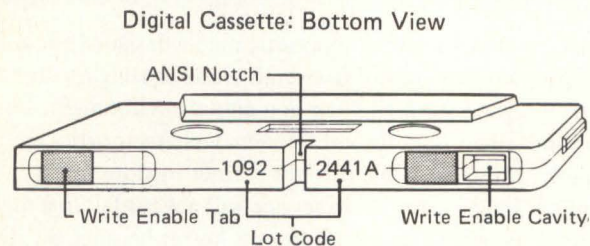

definition of terms

ANSI Locating Holes:	Holes fit over locating pins in drive to position cassette relative to head.
ANSI Notch:	Designates ANSI Standard Digital Cassette. Off center position useful in depicting which side is up.
ANSI Support Plane:	Flat plane along which cassette must be supported with minimum rocking.
Bridge and Tape Guides:	Reinforcement of monolithic bridge provides stability and deformation resistance to critical dimensions in head cavity area.
Capstan Access Holes:	Holes for capstan to fit into on capstan-type drives.
Head Cavity:	Head penetrates into cassette to reach tape in this area.
Hub:	High precision cylindrical surface on which tape pack is wound. Dimensions are critical.
Hub/Leader Lock:	Place where tape and/or leader is attached to hub.
Hub Spoke:	High precision projections mate with drive spindle for minimum whiplash.
Label Area:	Depressed area where label may be placed without rising above ANSI support plane.
Lot Code:	Number identifies lot this cassette is from.
Pressure Pad:	Pushes tape against head to provide good read/write performance. Pad size, material, and pressure are critical performance parameters.
Pressure Pad Spring:	Metal spring applies consistent, non-fatiguing force for pressure pad action.
Roller:	Rotating Delrin tape guide provides smooth tape motion. Must be highly cylindrical to avoid jitter.

Digital Cassette: Front View

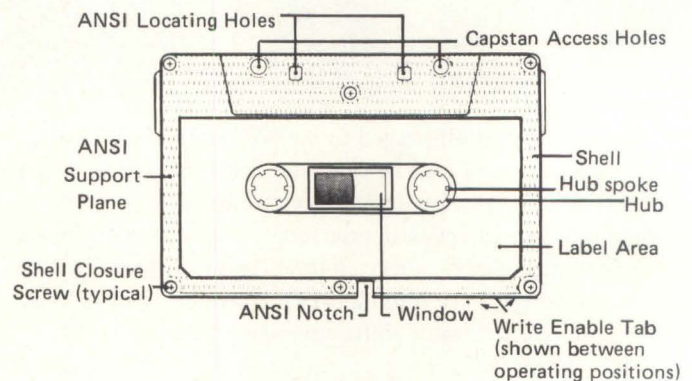

GETTING THE MOST FROM YOUR CASSETTES

Digital tape cassettes are designed to provide optimum service and extended life when used in data storage applications. They are precision devices, built to more exacting specification than cassettes used in audio equipment. Reasonable care in handling and storage lengthens the service life of cassettes. These factors are of critical importance.

handling and storage

- Keep the cassette at least three inches from equipment that generates magnetic fields, such as motors, fluorescent lamps, transformers, etc.
- Keep cassette out of direct sunlight; do not allow its temperature to be changed suddenly over large ranges because this can distort tightly wound tape.
- Store the cassette in its box when not in use. Keep it in a dust and lint-free environment.
- Avoid touching the tape surface; fingerprints contain oils that attract dust and other substances that damage tape.
- Remove tape from tape transport only after it has been rewound.
- Avoid dropping the cassette or subjecting it to sharp shocks that may damage the precision bearings. Normal handling

should not cause any difficulties.

- Protect the tape cassette and tape transport from tobacco ash and smoke.
- Never remove the tape from the cassette.
- Examine incoming cassettes for signs of shipping damage. Don't use units suspected of being damaged.
- Neutralize possible mistreatment in shipment by rewinding each tape twice before using it the first time. Wind it all the way forward once, then all the way back. Use a tape transport to do this — do not attempt it manually.
- Store in conditions approximating temperature and humidity conditions in area of use.
- Use pressure sensitive labels with nontransferable adhesive if you are mounting your own labels. Avoid embossed plastic labels; they tend to shed fine particles that can cause contamination.
- Periodic adjustment to the tape transport not only extends tape cassette life, but also helps to keep your entire system working to specification, which will help avoid loss of data. Follow the transport manufacturer's recommendations for periodic preventative maintenance.

Following the simple, common sense suggestions above, will give you the best possible service from your cassette.

Digital Cassette: Opened View

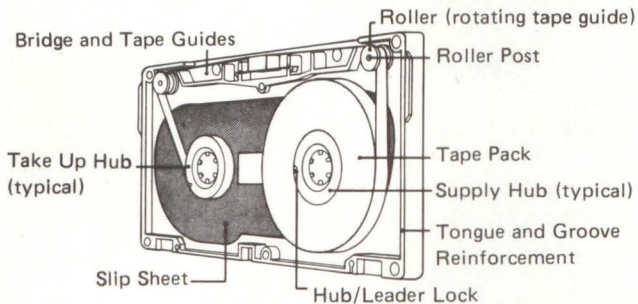

Digital Cassette: Top View
(Tape Removed)

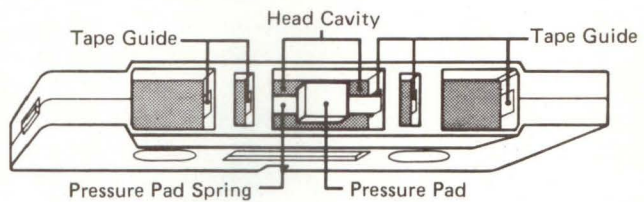

Roller Post:	Axis upon which roller turns. Must be exactly perpendicular to avoid skewing the tape or forcing it to one side.
Shell:	The outer enclosure of the cassette must be molded precisely to meet ANSI specification. Must withstand abuse; should be rigid to prevent warp and skew.
Shell Closure Screws:	Make shell a rigid package, but permit opening of cassette for in-process inspection.
Slip Sheet:	Low friction liner reduces tape pack abrasion.
Supply Hub:	The hub from which tape is being drawn while the cassette is operating. (Either hub can be the supply hub, depending upon direction of tape travel.)
Take Up Hub:	The hub onto which tape is being moved when the cassette is in operation.
Tape Guides:	High precision, perpendicular guides control tape path, limit skew.
Tape Pack:	Generic term for the rolled up tape on the hub. Pack winding must be tightly controlled to avoid stepping (projecting tape edges subject to abrasion).
Tongue and Groove Reinforcement:	Provides extra warp resistance to shells when assembled. Also helps keep dust from infiltrating into cracks.
Window:	Provides method of checking tape location; ultrasonic welds keep it firmly attached to shell on all edges to keep dust out. ITC never glues windows in.
Write Enable Cavity:	This cavity is exposed to permit entry of cassette drive write enable detection probes.
Write Enable Tab:	Tab flips over to permit data written on tape to be protected. When covering the write protect hole, the drive is enabled for writing on the tape.



Fig 1 Typical mini media L to R — rear: diskette, minidiskette, magnetic cards; front: mini data cassette, data cartridge, data cassettes.

its rigidity, ability to hold tolerances and even its dimensional consistency from unit to unit. In a cassette, this is critical, because the shell influences the tape position. Similarly, the use of ribbed rather than flat slip sheets adds greatly to cassette performance, because it keeps the tape centered and helps minimize skew.

The pressure pad of a cassette, which is usually required to insure good head/tape contact, is the major element in de-

termining system drag. It should be consistent in dimensions, location and spring force to avoid undesirable performance variations. The pad construction utilizing foam or felt mounted on a spring is the most consistent. The rollers must be made to exacting physical dimensions to minimize drag, tape damage, and speed modulation due to dynamic drag variations. Cassette drives using read after write (dual gap) heads generally require a larger pressure pad than those using a single gap head because the tape must be in head contact over a larger area.

The mechanical elements of the ¼ inch cartridge are even more critical than those of a cassette. The ¼ inch cartridge, which is frequently seen as a replacement for inexpensive ½ inch tape drives, is rapidly being developed to tolerances permitting operation of 6400 bpi on suitably designed drives, permitting capacities to 10 megabytes on a single ¼ inch cartridge. Even such simple mechanical features as the notches on the side of a diskette jacket are important; they provide strain relief and help keep the jacket flat.

certified magnetic media

Everybody has certified media, right? Right! And all certified media are the same, right? Wrong! There are three methods of certification in use today, and they produce vastly dif-

ABILITY OF MAGNETIC MEDIA TO WITHSTAND ABUSE

In 1972, the National Bureau of Standards issued a report covering the effects of **Various Hazards on Magnetic Material**. For mini-media users concerned about the effects of environmental hazards, the following material may be helpful.

Effects of Magnetic Fields — Strong fields can alter or destroy data. Keep media at least three inches away from transformers, large motors and other field generating equipment.

Effects of Microwaves — Microwaves have little effect unless the media is in an extremely strong field such as that produced in the inside of a microwave oven. External fields will have no effect; they are too weak.

Effects of Nuclear Radiation — Radiation will not affect the recorded signal per se, but exposure to moderate radiation over a long period might degenerate the plastic. In general, a radiation field strong enough to cause problems with media materials is also a human safety hazard and is unlikely to be encountered.

Airport Metal Detectors — Digital media can be taken through these with no discernible effects. The X-ray machines now in use will not damage magnetic media nor will they alter the data. Most magnetic metal detectors usually will not alter data, but it is wise to avoid taking them through these devices. Have airport security X-ray or hand inspect.

Lightning Strikes — The bolt must hit within 10 feet to cause noticeable damage to the information recorded on the media.

Shock and Vibration — Shock and vibration can cause the tape packs to shift and become stepped. This condition can produce high torque and possible tape jamming until a cassette is rewound (rewinding eliminates the step if the transport is properly designed); rough handling of cassettes is inadvisable for this reason. Data cassettes with ribbed slip

sheets resist the tendency of the pack to become stepped and are less subject to handling damage.

Dust and Fine Particles — Dust and fine particles can cause dropouts if they are embedded in their jackets or boxes or an equivalent dust free medium. Drives should be located in dust free areas and cleaned occasionally with isopropyl alcohol and a swab or some other appropriate cleaning device per manufacturer's instructions.

Temperature and Humidity — A frequent cause of mechanical damage, such as warping or tape stretching, is the storage of media in a hot environment, i.e., a car parked in direct sunlight. The car's internal temperature can exceed 60°C (140°F) for extended periods. You can purchase units rated for such extreme temperature environments. Low humidity can be a problem because electrostatic attraction due to charge built up on moving tape can cause dust and fine particles to adhere to the tape. Backcoated tape suppresses this tendency which is most pronounced at relative humidity lower than 40%. The cassette slip sheet, which is conductive, also helps. Relative humidity exceeding 80% at temperature exceeding 60°C (140°F) may cause tape surfaces to wear unusually rapidly. All tapes are subject to this phenomenon, some more so than others. If you intend to operate any media in a high temperature, over 40°C (104°F), high humidity (over 80%) environment, contact the manufacturer for consultation.

Chemical Solvents — Most volatile solvents can alter the wearing qualities of all commonly used magnetic media. For this reason, don't store media in areas where solvents are used. In most organizations, the only solvents likely to be a problem are those used in spirit duplicators and other liquid process copiers. Storage in the jacket or box will provide nominal protection against transient vapor concentrations.

OUR TRIDENTS ARE SO WELL MADE THEY'LL COME APART IN 10 MINUTES.

We've made it very easy for you to get to all the parts and components of every Trident disk drive.

You can remove all sub-assemblies without using a soldering iron. They all either slide right out, or fold out on hinges.

You can connect an exerciser to troubleshoot without removing any system cables.

The degate switch on every Trident lets you take out one drive for repairs without interrupting the others.

And since all critical sub-assemblies are enclosed to prevent contamination, they stay clean when the skins are off.

MAINTENANCE

All this means that when you need to maintain a Trident, you don't have to pamper it.

You can take it apart fast. Get the work done simply. And get it back together fast.

But design excellence is only part of the Trident story. Capacities range from 27 to 312 megabytes, and each Trident model is fully compatible with every other Trident model.

Each gives you track-following servo technology—plus one of the lowest cost-per-byte ratios in the industry.

TRIDENT FORMATTER

Our 1150A Formatter is also easy to maintain. It offers micro/minicomputer systems designers important features



previously available only in large disk controller subsystems. Features like ECC, RPS, and overlapped seek.

It can control and format any mix of up to eight Trident drives—for a total storage capacity of up to 2.4 billion bytes online. And it can be attached to virtually any micro/minicomputer.

STATE OF THE ART

If features like these are important to your growing systems business, you'll want more data on the state-of-the-art Trident family. Just call us at (714) 821-2011, or fill out the coupon. We'll do the rest.

DD-M6-77

To: California Computer Products, Inc. MS3
2411 West La Palma Avenue
Anaheim, California 92801

Please tell me all about your Trident Disk Drives.
 I am interested. I am serious.

Name _____
Company _____ Title _____
Address _____ Phone _____
City _____ State _____ Zip _____

CALCOMP

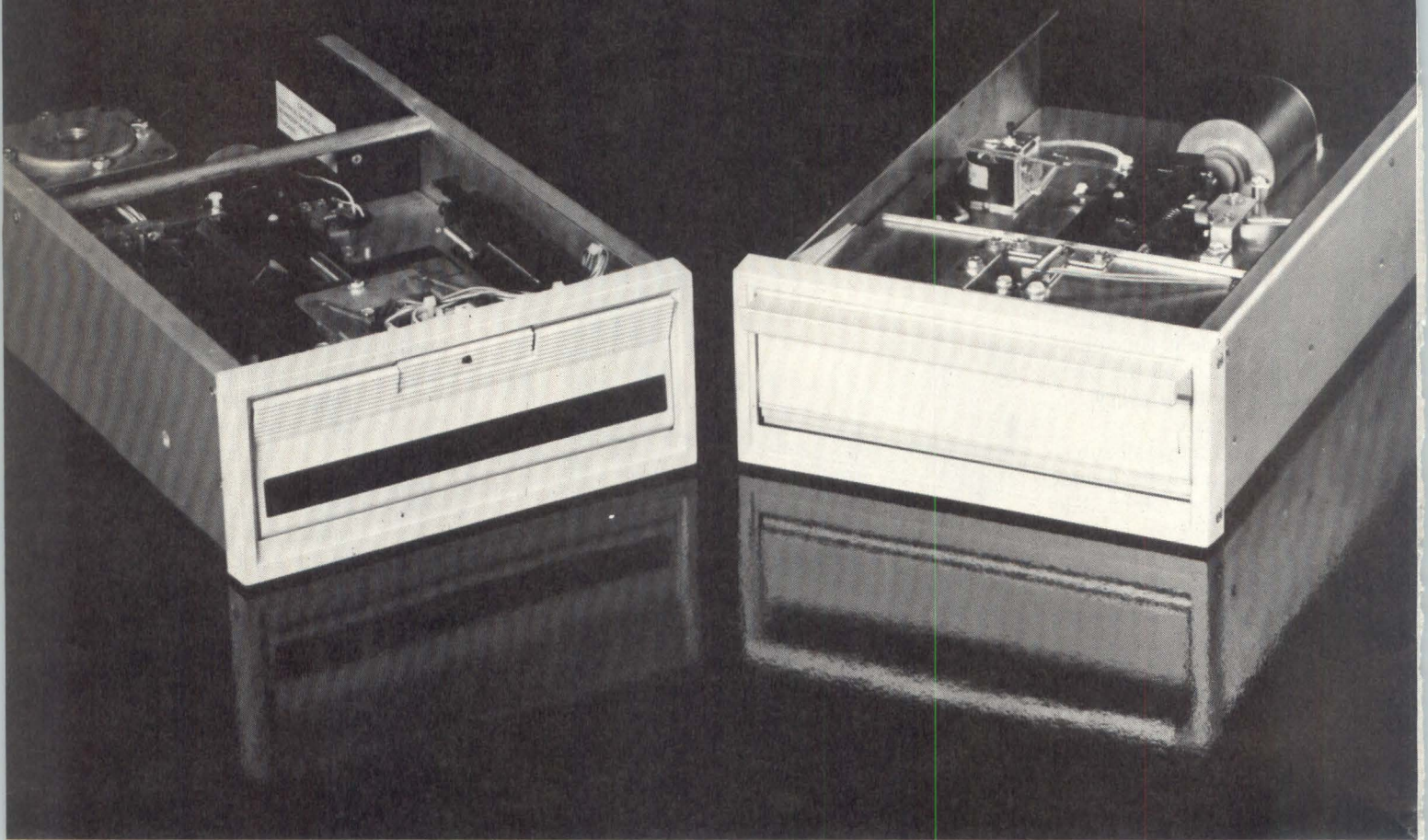

Unlike the others.

Pertec flexible disk drives are never referred to as, "Just like the others." (You never hear someone say, "You can't tell 'em apart!" Or, "It doesn't make any difference which brand you buy.")

The pure and simple fact of the matter is: *Flexible disk drives are not all the same.*

Some brands are smaller than others. And some are heavier. And some have more features than others.

However, each is an incredible piece of sophisticated equipment. And each is an important and integral part of every major OEM's system plans.

Our competitors make fine products.

The Pertec flexible disks *were not the first in the marketplace.* It's true.

But, perhaps we've taken advantage of our competitors: Instead of investing our resources in market development, we invested in product development.

(And the first thing we proved? A steel chassis definitely provides superior temperature stability; superior alignment stability; superior data reliability.)

Let's face it, you can't enter a quality marketplace with anything *other than* a quality product.

And today's marketplace is a buyer's paradise.

Buyer's Paradise: Pertec Exclusive #1.

Choice of Power:

The FD500, on the left, is our AC model (with double-density capability); the Pertec FD400, on the right, our DC model.

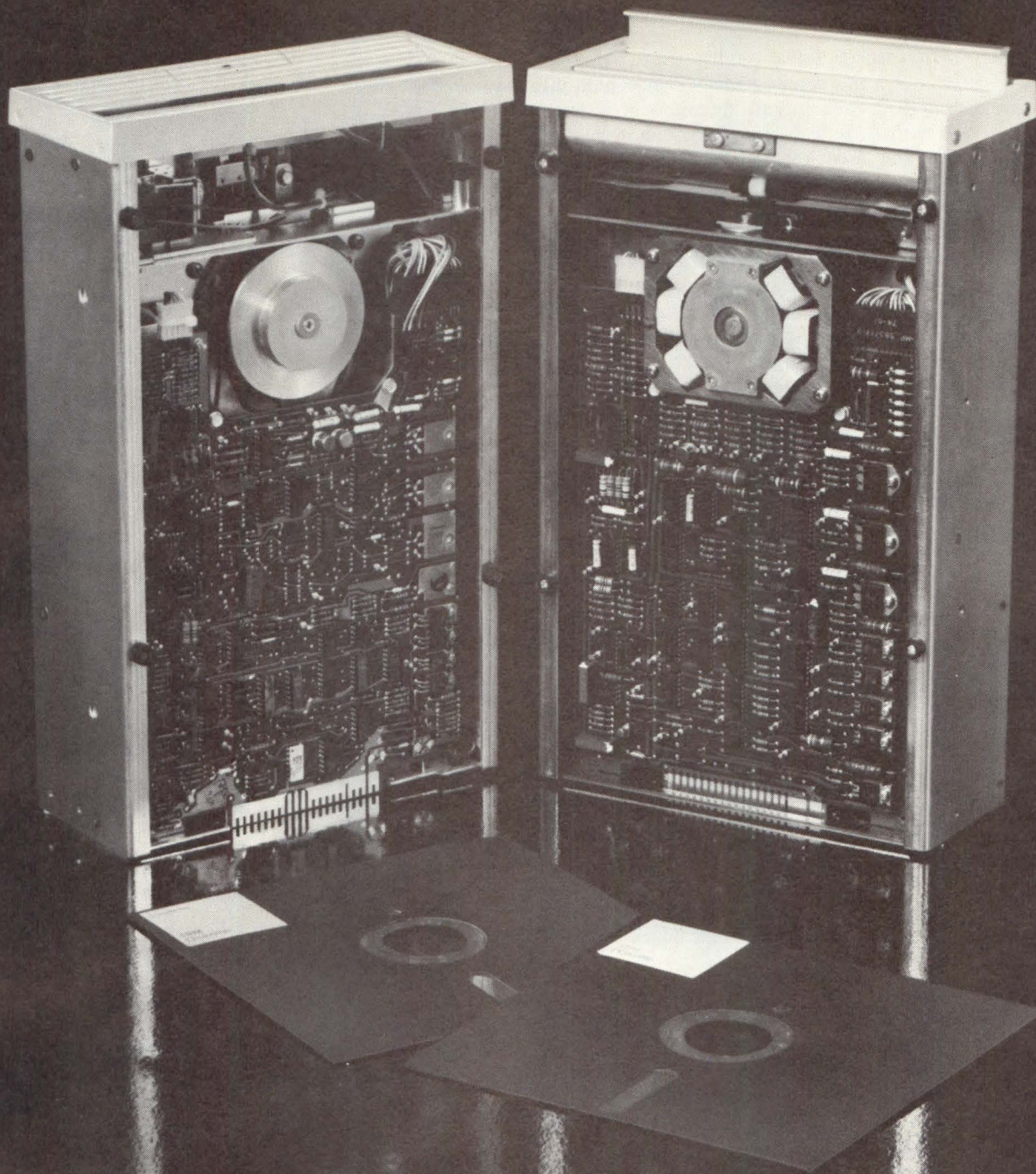

Totally.

Buyer's Paradise: Pertec Exclusive #2.

*Pressure Pad and Head Retract System:
No head or pad contact with media when unloaded.*

Buy the whole, feature-loaded, Pertec unit.

The FD400 and FD500 are identical in size: 3.45" x 8.6" x 14.2". *Very small. Very compact.* (And you can mount two units *horizontally*, or four *vertically*, in a standard RETMA enclosure.)

Both are compatible with IBM magnetic recording media. (And both have our Pertec Ceramic/Ferrite read-write heads with 20,000 hour head-life. And, 5.0 million passes on a single track!)

And both have our stepper motor with its *3-Steps-Per-Track-Action* (for superbly accurate positioning).

And, the FD500 has its own exclusive: A "Goof-Proof" two-state locking door. Eliminating inadvertent media access.

Pertec flexible disk drives: *Totally* unlike any others: With superior track positioning. Sharply reduced dead-band (backlash). And the media interchangeability you're looking for.

Now, who said, "All flexible disk drives are the same?"

PERTEC

For more information, call the Pertec office nearest you: Boston (617) 890-6230; Chicago (312) 696-2460; Los Angeles (213) 996-1333; London (Reading) 582-115. Or, write: Pertec, 9600 Irondale Avenue, Chatsworth, California 91311.

HOW TO PROTECT YOURSELF FROM DAMAGED DATA

Everyone knows that strange things can happen to data if a computer malfunctions, and there are many checks built into modern systems to detect and correct the results of system malfunctions. Once that data gets stored away on magnetic tape, you can relax and heave a sigh of relief, right? Well, maybe, depending upon the measures you have taken to insure the integrity of your stored data.

But what can go wrong . . . you say. Lots. For instance suppose you are storing data on a cassette that has been around for a while and has been running on a drive that is not in perfect adjustment. That cassette may have a few wrinkles or ripply tape edges that are just waiting for a chance to become dropouts. And, of course, that will happen at the one time you have valuable data to recover and your only copy is on the damaged tape. This, of course, is in complete accordance with Murphy's law, and should surprise no one.

So what can you do about it?

first -- institute a rigorous program of inspection.

- Examine your media handling procedures. Have you been leaving magnetic media around without storing them in their boxes or jackets? Chances are you now have a lot of dust particles on the media. These not only cause dropouts, but can cause excessive head wear if there is a lot of dust. Do you store cassettes on edge to minimize the possibility of pack shifts? Do you store diskettes on edge to minimize jacket warp?

- Examine those cassettes and cartridges. Winding the tape forward slowly, examine the first twenty-four inches or so for wrinkles (deep creases) or rippled tape edges. If you find any, immediately transfer the data on that cassette to a new cassette. Creases and ripples are signs of an impending failure of the tape. Also check to be sure that large pieces of oxide coating are just flaking off the tape edges. This will also eventually cause an error.

- Date the media label when first used. If you have media that has seen very active service and it is more than two years old, you may want to consider replacing it with a newer unit. Not all impending problems show up easily on visual inspection and why take a chance on losing important data? Some of these subtle problems are:

Tape Cinching: Caused by fast stop/starts on drive where winding tension is too low. Can frequently be detected as a gap in the tape pack when looking through the cassette window. (Fig 1)

Tape Pack Shift: Appears as a step in the surface of the tape pack when viewed through the window. Can usually be eliminated by winding to end (on the drive) and then rewinding, but if this condition exists for a long time, edge creasing can result.

Tape Ridges: Caused by scratches or debris on inner layers of tape. These can propagate through a tightly wound tape pack and produce permanent tape deformations — a source of dropouts.

Normal Wear: Under a microscope, well-worn media will show lumps of debris. These lumps are composed of oxide particles deposited over time on the head and then redeposited on the tape as a lump. If large enough, these lumps cause head to tape separations large enough to cause dropouts. This type of wear is typical of all magnetic media.

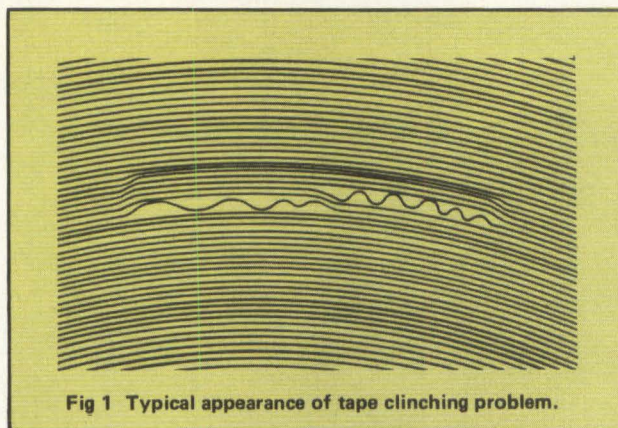

Fig 1 Typical appearance of tape cinching problem.

second -- back up critical data.

- Store critical data on a backup from your working tape on a regularly scheduled basis. This is very inexpensive insurance against all kinds of catastrophes that might damage a system or its storage media. Some organizations maintain as many as three tiers of backup of critical data.

- Make a duplicate of daily tapes or disks if possible.

- Weekly, make a copy of your most recent daily tapes or disks. Update this set on a weekly basis.

- Monthly, make a copy of your most recent weekly tapes or disks. Update this set on a monthly basis.

All of the backups should be stored in a safe place until used the next time. Backups should be rotated yearly so that a fresh set is always in use.

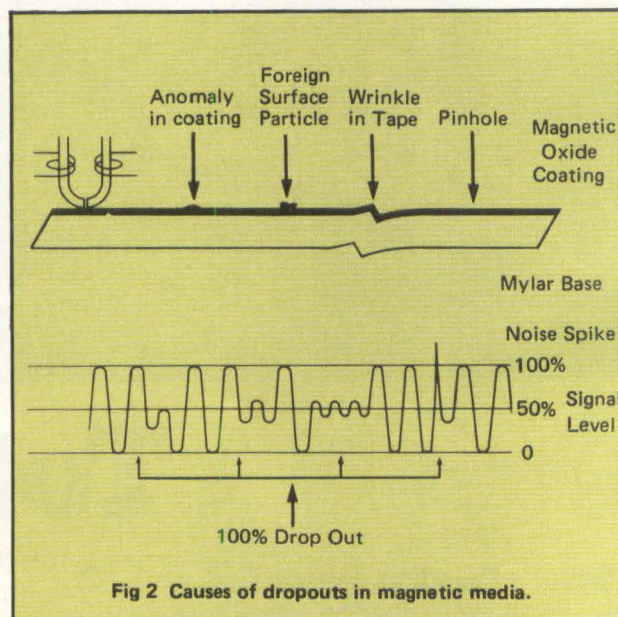

Fig 2 Causes of dropouts in magnetic media.

third -- keep your equipment in good condition.

- Scheduled preventive maintenance is your best insurance against equipment malfunction. If your equipment typically indicates impending failures by goofing up some operations, make up a cassette or disk with those operations on it, and use it once a month to check the system. Otherwise, follow the manufacturer's suggested schedule.

Now you have a choice of DEC[®]-compatible floppy disk systems.

The DEC RX01.
It costs \$4,095.
You can wait months for it.

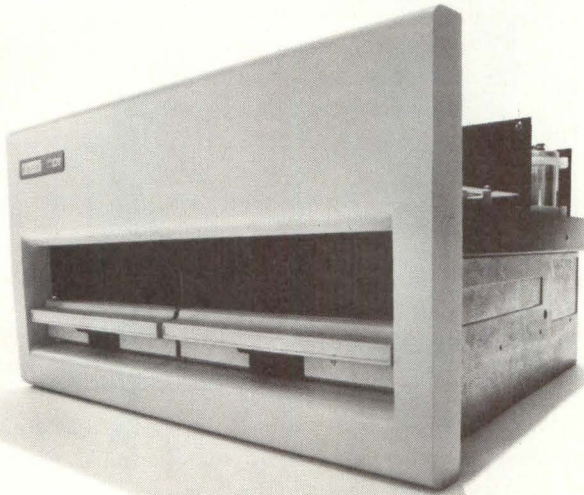

The DSD 210.
It costs \$3,295.
You can have it in weeks.

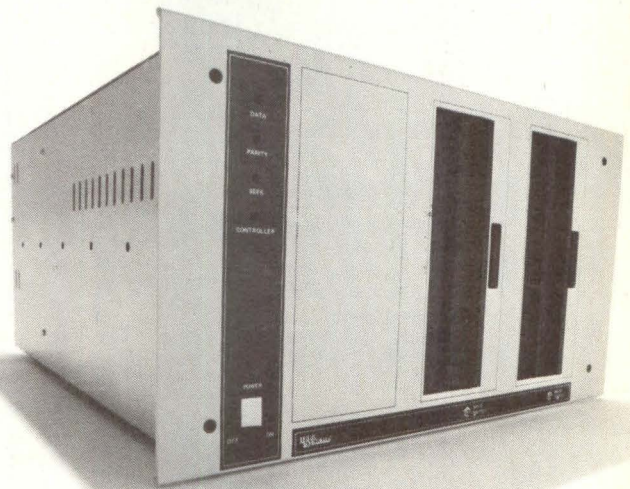

YES	PDP [®] -8, PDP [®] -11, LSI-11 plug compatible	YES
YES	Software compatible with all DEC operating systems	YES
YES	IBM 3740 Format	YES
NO	Write protect switches	YES
YES	Automatic head unload	YES
YES	Ceramic read/write head	YES
YES	Holds 256,256 bytes per diskette	YES
NO	Diskette formatting capability	YES
1 OR 2	Drives per controller	1, 2, OR 3
NO	Interchangeable 50/60 Hz operation	YES
YES	Digital phase-lock-loop data separation circuit	YES
NO	Front panel activity LED lights	YES
NO	Front panel system status indicators	YES
PARTIAL	Modular construction	COMPLETE
MINIMAL	Self-testing microcode	EXTENSIVE
NO	Field-proven Shugart drives	YES

Our DSD 210 floppy disk system is 100% hardware, instruction set, and media compatible with all DEC PDP-8, PDP-11 and LSI-11 systems. It costs \$800 less than DEC's RX01, has a far shorter delivery time, and has more useful features.

**Data
Systems**

For an expanded comparison and complete technical details, phone or write Data Systems Design, Inc., 3130 Coronado Drive, Santa Clara, CA 95051, 408/249-9353.

[®]registered trademark of Digital Equipment Corporation

**10 MBytes
...take your
pick.**

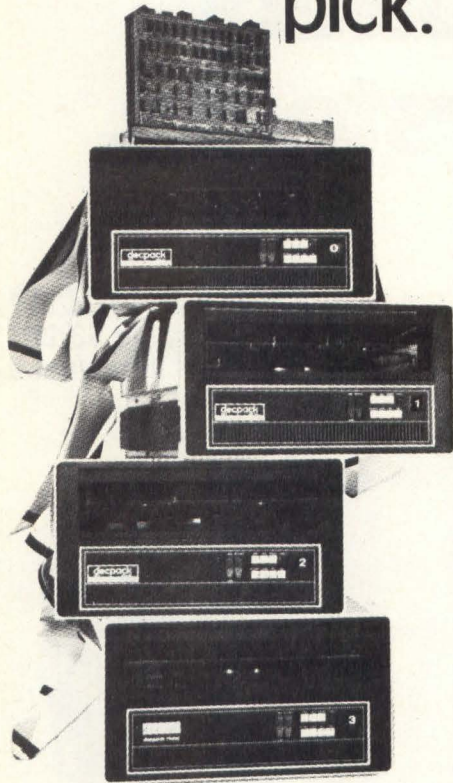

DEC
\$26,000
6 Months Delivery
1.56 MHz Transfer
70 ms Positioning

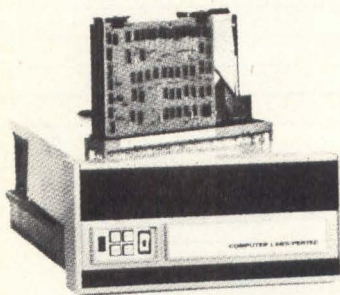

COMPUTER LABS
\$10,700
45 Days Delivery
2.5 MHz Transfer
40 ms Positioning

**COMPUTER
LABS**

The Mini Peripheral People

COMPUTER LABS, INCORPORATED • 505 EDWARDIA DRIVE
• GREENSBORO, N.C. 27409 • TWX 510-922-7954 • (919) 292-6427

Minimizing Drag: Cassette Slip Sheets

Slip Sheets are sheets of low friction material placed in a cassette between the tape pack and the interior sides of the cassette shells. The purpose of slip sheets is to minimize the drag of the tape pack against the side of the shell by interposing a low friction, abrasion resistant surface. A properly designed slip sheet guides the tape as it is wound or unwound, providing a centered, evenly wound tape pack without protruding tape edges that are easily damaged.

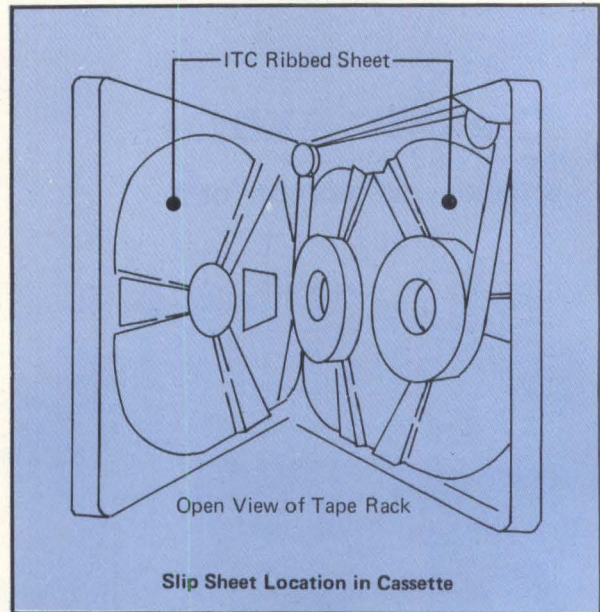

While all digital cassettes have slip sheets, they are far from being the same. Information Terminals Corporation uses two die cut slip sheets in each cassette. Each sheet has six ribs precisely formed into its surface, three radiating from each hub opening. The ribs have a flat surface that bears against the tape pack. Rib height is tightly controlled, producing a flat tape pack that is centered in the cassette. These ribs prevent lateral or transverse rotational pack motions during winding, thus minimizing dynamic skew. The precision of the rib formation provides a more consistent damping during stop-start operations.

High resiliency material is used to form the slip sheet. This provides a cushioning effect against sharp shocks, thus preventing stepped or uneven tape packs, a common cause of excess drag in cassette systems.

Slip sheets are slightly conductive to aid in eliminating static charges that can build up along tape surface. These charges, if present, can cause layers of tape to stick together, increasing drag. Worse, it causes dust particles to be attracted to the tape, which can cause dropouts and accelerated head wear. The conductive slip sheet is an important factor in minimizing these effects. The broad, planar surface of the formed rib is especially effective as a static discharge path.

*Information supplied by Information Terminals Corp.,
323 Soquel Way, Sunnyvale, CA 94086.*

Boschert is the new leader in low cost, OEM Switching Power Supplies

—in fact we're price-competitive with linears!

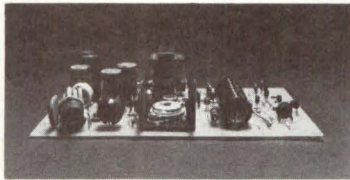

For example: our 50 watt has 4 outputs, weighs only 14 oz. and costs less than \$100. —just right for microprocessors.*

Our standard switchers produce 50 to 300 watts with 4 to 6 outputs, and protection against short circuit, reverse-polarity and over-voltage is built in.

Our state-of-the-art experience with the F-14 and four satellite programs coupled with volume production for corporations like Diablo and Qume insures high quality at low cost.

So, if you're in the middle of designing a printer, display, data storage or microprocessor system and you want to save not only heat, weight and space but dollars, then call us collect for the name of the Boschert Sales Engineer nearest you.

We're the new leader.

boschert

384 Santa Trinita Ave. ■ Sunnyvale, CA 94086 ■ 408 732-2440

**in quantities of 100 or more.*

Personal Computing

An exciting, new magazine!

If you don't have your own computer by now, chances are there's one in your immediate future. Personal computers are now being sold at about the price of home stereo systems. Experts project that 1,000,000 personal systems will be up and running by 1980.

PERSONAL COMPUTING will serve as your guide into this exciting new technology. We'll provide you with all the up-to-date information on new computer products, computer stores, and important personal computing events. In addition, each issue contains easy-to-follow, nontechnical articles on computer programming and computer jargon. These articles illustrate how you can use personal computers at home, school, and work.

Get your FREE issue now

Fill out the subscription form below, and we'll send you a complimentary copy. If you don't agree that Personal Computing is everything we say it is, simply write "Cancel" on the invoice and return it to us. If you do want to subscribe, simply pay the bill. In any case, the first issue is on us!

A one year subscription to PERSONAL COMPUTING is just \$8.00.



Please enter my subscription to Personal Computing.

I understand that the first issue is free.

Bill me Enclosed is my check for \$ _____

Bank Americard Master Charge Am Express

Credit Card # _____

Credit Card Expiration Date _____

Name (print) _____

Address _____

City _____

State _____ Zip _____

Note: PERSONAL COMPUTING is a bi-monthly publication. Credit card billing available to U.S. subscribers only. Rates: for 6 issues \$8 in the U.S. Additional postage for Mexico and Canada \$2 surface mail and \$4 airmail; all other foreign \$4 surface mail and \$18 airmail.

PERSONAL COMPUTING

167 Corey Road, Brookline, MA 02146, USA

ferent results in product quality as perceived by the end user.

These methods are:

- Statistical Certification
- Bulk Certification
- Post Assembly Certification

exactly what is certification, anyhow?

Certification is the process of writing a pattern of flux changes on the magnetic media and then reading it back, checking for proper signal amplitude during readback. If the readback signal falls below a certain preset threshold, then a dropout is said to occur. If the cause of the dropout is a defect in the media, the dropout condition will generally exist over a region of the media. Point dropouts are usually caused by damaged media or by a foreign particle that has adhered to the media. Media should be assembled in clean room conditions to minimize the possibility of such contamination.

statistical certification

Statistical Certification is performed by certifying a sample of the media used in a production run. If the media sample is good, all of the lot is presumed good and fit for use. However, there will probably be a significant number of "bad spots" in the lot that will not be detected until the end user encounters them in the form of an error in his system. Statistical Certification is usually performed before the media cartridge is loaded, and some times even before the media is slit. This creates abundant opportunities for the creation of defective product; typically 8 to 10% of the units shipped will have dropouts or other defects.

bulk certification

In bulk certification, the media is usually certified after slitting, but before loading into the end product. All of the media is tested. The disadvantage of this method is that damage occurring during media loading, testing or subsequent manufacturing steps is often undetected until the unfortunate user discovers it the hard way. While superior to Statistical Certification, this method still leaves much to be desired. It is used extensively, though, because it is cheap, but can result in a typical defect rate of 4 to 6% of the units shipped, depending upon the thoroughness of the supplier's quality control effort.

100% post assembly certification

After the product is assembled, it is placed in a specially designed certifier which tests it for dropouts and, in the case of cassettes, other parameters such as tape length, leader length, presence of BOT/EOT holes and the proper hole location. A product passing this type of certification has an extremely high probability of meeting the users performance expectations. Dropouts in shipped products are nil.

Bob Katzive is from Information Terminals Corporation in Sunnyvale, California.

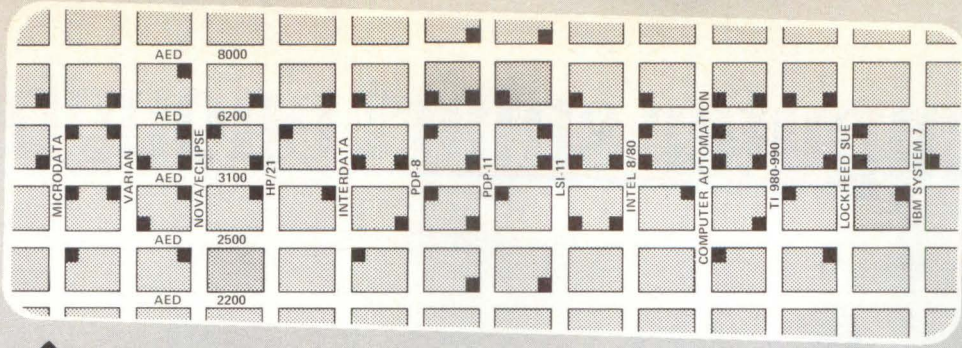

Deep in California lies Disk City, a rapidly-growing metropolis offering the world's most complete selection of rigid and floppy disk systems. The streets are computers and the avenues plug-compatible disk controllers. Cost-effective disk systems appear at no less than sixty-six locations. These systems range in size from the tiny hard-sectored AED 2500 floppy to the AED 8000 skyscraper, which fully emulates RP11-C/ROP3 or 4231/4231A. Middle range units include the soft-sectored floppies; IBM-compatible 3100's and double-density 6200's, and the RK-11/RK-05 compatible 2200 Cartridge Disk System. So come to Disk City—it may be the best move for you and your data.

 **Advanced Electronics Design**, P.O. Box 61779, Sunnyvale, Calif. 94088 Phone: 408-733-3555 Telex: 357489

Welcome to Disk City

Population: Sixty-six systems and still growing



Is your computer smart enough

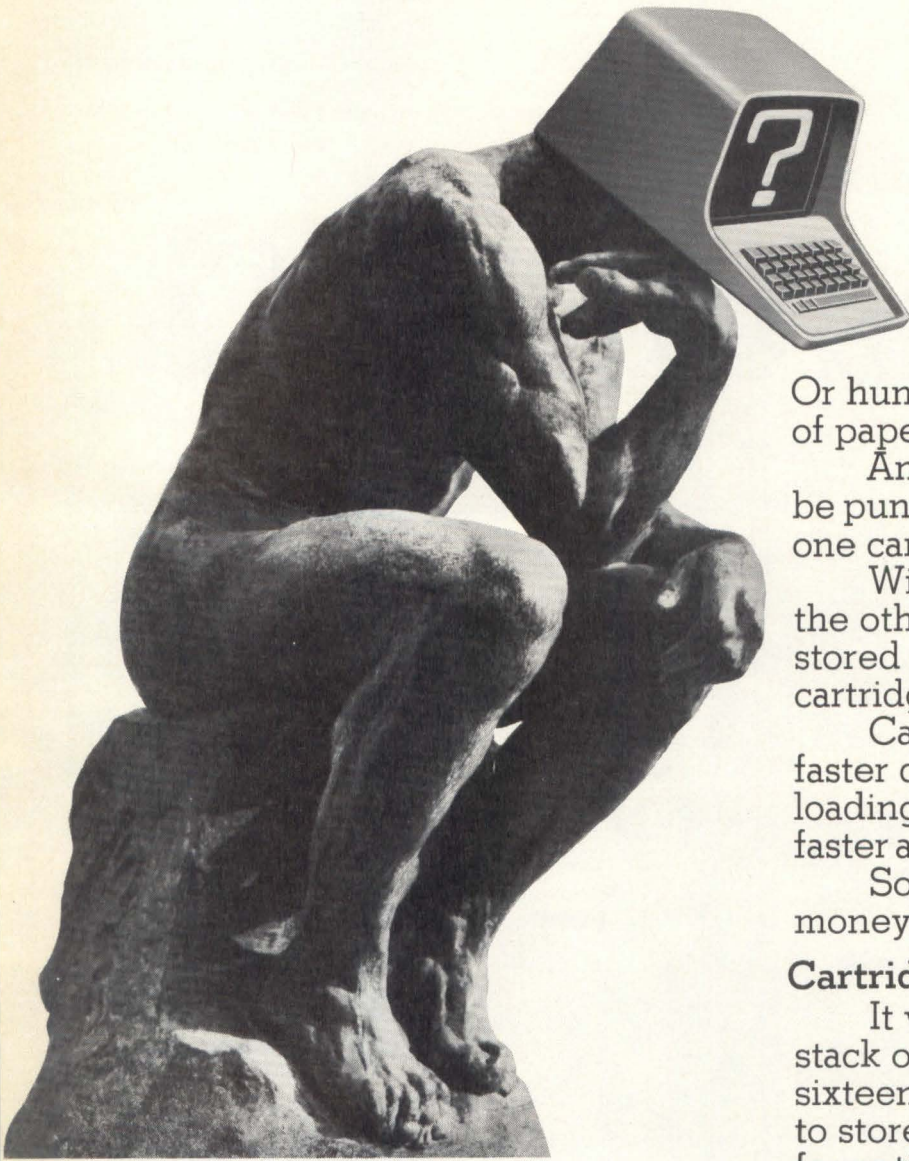

One DC-300A cartridge equals almost 16 feet of cards.

Or hundreds of feet of paper tape.

And each program must be punched, verified and read one card at a time.

With our drive system, on the other hand, programs are stored on a single tape cartridge.

Cartridges offer much faster data storage, program loading, data transfer and faster access to the computer.

So you save time and money.

Cartridges take less space.

It would take a stack of cards almost sixteen feet high to store all the information you can store on a single 3M DC-300A data cartridge.

With cartridges, you can store all of your programs in a fraction of the space you'd need for cards or paper tape.

Your filing system is simplified and overhead is greatly reduced.

Cartridges won't fold, spindle or mutilate.

Unlike paper cards, you need never touch the media. It's well

A 3M peripheral drive which uses 3M data cartridges is better than any drive which uses punched cards or paper tape.

And, if you'd take the time to ask it, your computer would probably tell you so.

It's simple logic.

Cartridges are faster than cards.

Cards and paper tape are slow. It takes hundreds of cards for a single computer program.

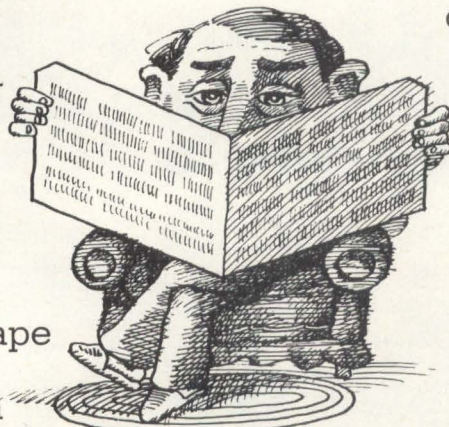

Cards must be read one at a time.

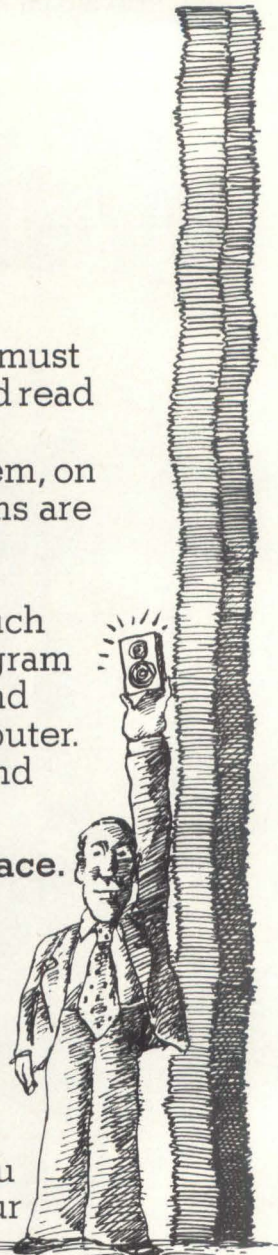

to choose our cartridge drive?

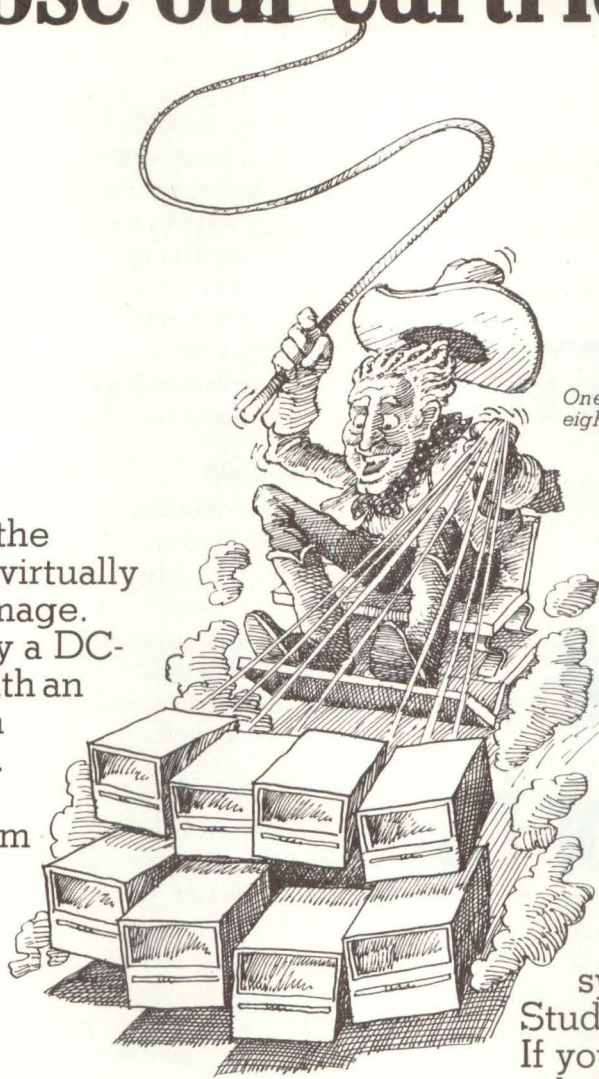

One formatter can control eight drives at once.

protected inside the cartridges, so it's virtually impossible to damage.

You can carry a DC-100A cartridge with an entire program in your shirt pocket.

Even if you drop it, the program will survive unscathed.

Remember that the next time you drop a stack of cards.

Don't take our word for it. Ask your computer.

If you'll send us the coupon, we'll send you the specifications for all three of our drive systems.

Ask your computer to compare them with any other type of drive system.

We'll bet your computer will prefer ours.

Maybe it'll choose our famous DCD-3 drive. It's people-proof, jam-proof and wear-resistant.

Or maybe your computer will decide upon our DCS-3000 series, an ANSI-formatted system that allows one formatter to control up to eight drives.

The DCS-3000 is extremely easy to integrate into your system. Only one cable to the user's logic is required.

But if you require compact size, your computer will probably choose our

unique DCD-1. It offers many of the features of our bigger systems, yet it will fit inside a five-inch cube.

The cartridge alone measures just 2.4 x 3.2 x .5 inches.

See for yourself.

Send us the coupon. There's much more we can tell you about our drive systems.

Study the information carefully. If your computer isn't smart enough to choose our drive systems, we'll bet you will be.

Send me more information.

Name Title

Firm Address

City State

Zip

Phone

3M
COMPANY

Mail to: 3M Company
Data Products, Dept. 125
Mincom Division, Bldg. 223-5F
3M Center
St. Paul, Minnesota 55101



Digital Recording In Low Cost Transports

by Clark E. Johnson, Jr.

Clark E. Johnson, Jr. is President of Micro Communications Corporation in Waltham, Massachusetts.

Historically, most digital engineers have looked upon magnetic tape peripherals as black boxes which were fairly easily connected to the computer without much concern for the magnetic recording process and its requirements. The advent of microprocessors and microprocessor-based systems has greatly increased the need for low cost tape storage, requiring the software to do more and more of the data manipulation, encoding and decoding. This article reviews the system constraints imposed by the magnetic recording and playback process and shows you how to overcome them. This article is restricted to direct digital recording; it does not include such analog and quasi-analog techniques as frequency selective keying (FSK) or other tone-burst approaches.

introduction

A magnetic recording system may be thought of as a bandwidth limited communications channel. We must, of course, ignore the time delay between the writing and reading of a given unit of information. Fig 1 shows the usual model of a communications system. It consists of five components: an encoder, a modulator, the communications channel itself, a detector and a decoder. Some of these elements may be combined in whole or in part and each of them will be briefly explored as to its relevance in a magnetic recording system.

Since we are concerned only with recording digitally, we first must review how a pattern of ones and zeros is laid down on the tape. Clearly, only two unique states of magnetization are necessary for the storage of binary data. These states are normally positive and negative saturation of the magnetic tape surface to give maximum differentiation between the two states. Saturation recording takes maximum advantage of the non-linear saturation characteristic of the magnetic recording medium. It is to be clearly distinguished from a normal analog recording in which only about 25% of the magnetic moment of the media is put to use. Thus, the output from a saturated recording is approximately 12 db higher than that of an audio recording. The magnetic material in saturation recording provides inherent limiting action which greatly reduces the effects of variations in write current, tape-to-head spacing and media parameters. Because of the use of saturation techniques, you cannot use a direct correspondence between the input and output of a magnetic tape channel and a conventional signal transmission system.

the encoder

The function of the encoder is to take raw data at the input to the system (a bit stream of zeros and ones) and transform it into another data stream that has been specifically conditioned for transmission through the channel. This conditioning serves a number of purposes: for example, the addition of parity bits, error propagation limitation, spectral shaping and speed tolerance. Note that with a microprocessor-controlled system, software easily accomplishes this encoding and subsequent decoding. A later section will go into detail on various encoding techniques.

the modulator

The purpose of the modulator is to take the digital sequence produced by the encoder and convert it into an analog waveform that can then be transmitted through the channel. In a communications system with linear but bandwidth-limited channels, the modulator normally serves the purpose of producing a waveform whose spectrum is matched to the band-pass of the channel. In magnetic recording systems where

magnetic and mechanical characteristics of the media itself such as surface finish, coating thickness, coercive force and saturation magnetization. The most accessible parameter to the user is tape speed which is directly proportional to the frequency response of the channel. Since the fundamental limiting feature of the magnetic recording channel is the tape/read-head interface, the read head is considered a part of the channel.

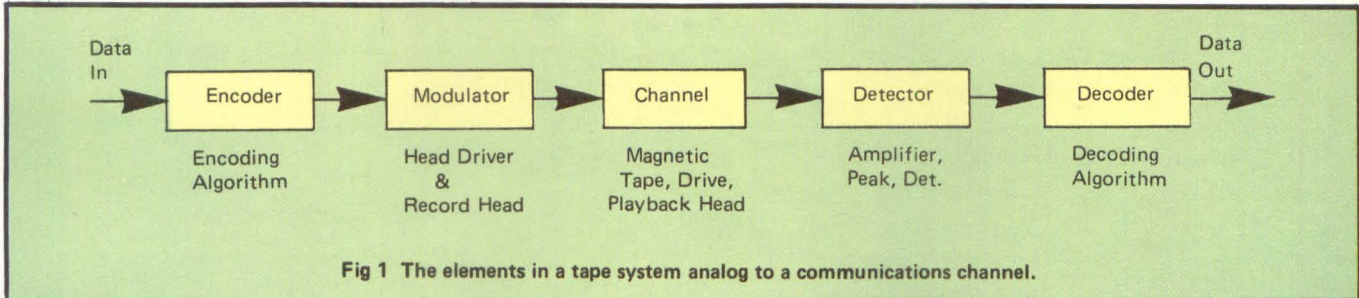

the channel exhibits both saturation and hysteresis effects, as well as a frequency limitation, the modulator must serve the additional function of setting the proper write current amplitude and switching characteristic. The modulator in a tape system therefore consists of the magnetic recording head and the head driver. Recording takes place at the trailing edge of the record gap by the fringing flux, since this is the area of the highest flux gradient. Excessive current in the record head simply moves the magnetizing zone downstream from the gap.

the channel

In the usual communications channel, there is normally very little control over the channel characteristics, and the rest of the system is designed around it. Things are not so fixed in the magnetic recording channel. The transmission (storage) medium can be controlled in several ways. These include the

Fig 2 shows the magnetic tape channel frequency response. Notice that at low frequencies the output rises at 6 db per octave in accordance with Faraday's Law. The output goes exactly to zero at the point where the recorded wavelength is equal to one-half of the playback head gap length. The peak of the response curve depends upon the magnetic parameters of the tape and can be pushed to higher frequencies by increasing the coercive force and decreasing the coating thickness. A main contributor to the roll-off of response with decreasing recorded wavelength on the tape is self-demagnetization. That is, as the recorded wavelength decreases, a decreasing amount of flux finds its way through the read head, and more of it is short-circuited through the tape itself. Clearly, significant advances in performance can be expected as tape materials and manufacturing techniques improve.

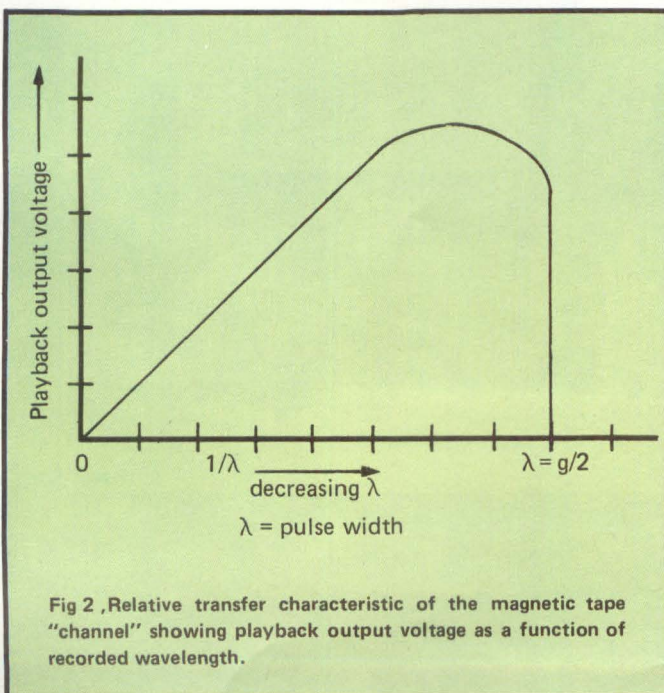

detector

The detector is the device that takes the incoming analog signal from the channel and converts it into a digital signal identical to that of the input to the modulator. Since, in the magnetic tape system, the read head is part of the channel, the detector is merely the amplifier and bit-by-bit detector, normally a peak detector. Note that the information content of the signal, located at the zero crossings of the record current, becomes translated to peaks of the detected voltage. The detector also recovers the timing information necessary to reconstruct the digital data stream.

decoder

The function of the decoder is exactly opposite that of the encoder: it takes the output of the detector and converts it back into the input data bit stream. Depending upon the type of encoding used, the decoder may correct errors in addition to performing the inverse algorithm of the encoder.

recording density limits

Since the recording process itself takes place at the trailing edge of the write-head gap, bit density on the tape does not

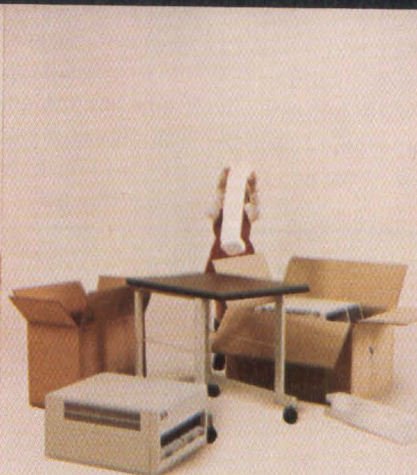

Digital introduces DECstation. A big computer system that's small enough for anyone.

Digital put an amazing LSI version of the PDP-8 inside a DECscope, added some ingenious interconnecting devices and created something new. The DECstation. A complete computer system big enough to do all kinds of work and small, simple and inexpensive enough to do it for almost anyone.

DECstation. A complete computer system in disguise. It looks like a terminal, but look again. The DECstation has a powerful general purpose computer, a video terminal, a dual diskette drive, and its own special operating system. What's more, you can hook up two different printers and a second dual diskette drive. Then put the whole thing in a mini-desk, and when you're done you'll have the smallest big computer you've ever seen.

The Video Data Processor. It's the big reason the DECstation's so small. The VT78 Video Data Processor is a computer wrapped in a terminal. Inside the familiar DECscope you'll find an LSI version of the PDP-8 with 16K words (32K characters) of MOS memory and built-in interfaces. Two serial asynchronous ports feature speeds from 50 baud to 19.2 kilo-

baud. A disk port interfaces with up to 4 diskette drives. A parallel I/O port for printers and custom interfacing provides data transfer rates up to 180 kilobits/sec. All standard.

You can go from carton to computer in less than an hour. If you can push a button, you can run a DECstation. Because one button is all it takes to start things up. The bootstrap and self-test routines are built in.

Put it together, plug it in, and immediately you can begin to run anything from the PDP-8 software library. Which means you start with one of the most comprehensive sets of software tools available in a small system. Including two proven operating systems: OS/78 for stand alone applications and RTS/8 for real-time. OS/78, an extension of

OS/8, supports a number of languages, including FORTRAN IV and BASIC. So all you have to do is load the operating system and start programming your application.

Whatever that application, if you're looking for a sophisticated little system, at the right price, and a remarkable OEM tool, consider DECstation. \$7995 each. \$5436 OEM quantity 50.

For our free brochure, write Digital Equipment Corporation, Parker Street, Maynard, MA 01754. European headquarters: 81 route de l'Aire, 1211 Geneva 26. Tel: 42 79 50. In Canada: Digital Equipment of Canada, Ltd.

digital

PDP-8 Marketing Communications	DD6157
Digital Equipment Corporation, Parker Street, PK3-1, M34 Maynard, MA 01754.	
Send me the free DECstation brochure. (please print)	
Name _____	
Company _____	
Address _____	
City _____	State _____ Zip _____
Phone _____	OEM _____ End-user _____
Application _____	
_____ Please send additional information about the PDP-8 family.	

COMPARISON OF VARIOUS ENCODING SCHEMES

Encoding Scheme	Bandwidth (Fundamental)				DC Present?	Transitions Bit Density	$\frac{F_{max}}{F_{min}}$	Preamble?	Speed Tolerance		Notes
	DC	0.5f	1.0f	1.5f					Bit-to-Bit*	Long Term	
NRZ					Yes	1	∞	-	-	-	Listed for comparative purposes.
RZ					Yes	2	4	No	High	High Virtually Asynchronous	Requires demagnetized tape.
S-NRZ					Yes	1.125	9	Yes	Low	None	
Bi-phase					No	2	2	No**	±33%	±33%	Includes Manchester, Phase, FM.
Double Density					Yes	1	2	Yes	Low	None	Includes MFM, DM, Miller, etc.
Ratio					No	3	2	No	High	High	
3M VCW					Yes	2	2	No	±20%	±20%	Record length on tape depends upon ratio of 0's to 1's.

*Tolerance shown is total of both write and read.

**Some configurations require preambles.

Fig 3 Characteristics of various self-clocking data encoding schemes showing bandwidth (in terms of the fundamental frequency component of the data rate), the presence of dc in the recorded signal, the ratio of the transition density to bit length, the bandsread ratio, whether the scheme requires a lengthy (>1 bit) preamble and speed tolerance both a short-term (bit-to-bit) and long-term basis.

depend, at least to the first order, on the write-head-gap length. The cutoff wavelength (Fig 2) is directly proportional to the playback-gap length. There are, however, several other factors involved. One of these is head-to-tape spacing which greatly affects the playback output voltage and waveform. Reduction in output voltage causes errors in the detected signal because of insufficient amplifier gain to drive the detector. This reduction is dependent upon the ratio of band-to-tape spacing divided by read head gap length. Wave-shape broadening increases the effect of pulse crowding. Any non-uniformity of the head-tape interface such as debris on the tape or non-uniform surface, can cause an increase in head-to-tape spacing. As an example of how serious this is, a system which may exhibit one error in 10^7 bits at 800 bits-per-inch could easily exhibit one error in 10^3 bits at 1200 bits-per-inch using the same encoding scheme.

Pulse crowding is another effect that needs to be considered. In essence, the playback system (i.e., the detector) is linear and subject to the superposition theorem. The record process is very non-linear and depends upon the state of magnetization of the previous pulse, assuming that the magnetization did not reach zero before the next pulse came along. As a result, there is a phase shift of higher density pulses with respect to lower density pulses. Consequently, the detection window and amplitude of each pulse is dependent not only upon its own characteristics but those of its predecessor. Most manufacturers give specifications as to the acceptable maximum flux changes per unit length of tape for their system for low error rates.

signal processing techniques

There are basically two types of digital magnetic recording schemes: those providing a separate clock track independent-

ly recorded, and those which are self-clocking — that is, in which the data stream and the clock are encoded together into a single bit stream. Since this discussion is related to single-track recording, we are restricting ourselves to the latter case. One might legitimately ask why it is necessary to provide timing information at all. Why can't the data be recorded on tape and then played back using an independent timing oscillator identical to that used during recording? The problem is, of course, that tape systems, being mechanical, cannot provide the precise tape speed control necessary to make this feasible. In fact, it is even difficult to take the serial output from a UART, record it on tape, and then play it back on a different machine into a UART and recover error-free data. The reason for this is that the data timing between input and output can only change by 4% over one byte to faithfully recover the data. As a consequence, it is essential to provide independent clocking on the channel itself.

There are a number of self-clocking codes that can be used with digital recording. One author reports over a hundred of them, but most of them can be reduced to half a dozen or so basically different schemes. If we now refer to Fig 2, we note that dc cannot be transmitted through the magnetic tape channel. In fact, to reduce equalization, it is desirable to reduce the bandwidth spread as much as possible. Fig 3 shows the characteristics of various types of self-clocking codes (with NRZ included for the sake of comparison).

The abscissa of Fig 3 is the fundamental frequency bandwidth component required in terms of the data rate. The columns at the right indicate various characteristics of these codes. "DC Present" is whether or not the encoded waveform is asymmetric; that is, does it include a dc component. The second column is the "Ratio of the Transition Density to the Bit Density," which is a measure of the efficiency of



altair™ floppy disk system

Disk capabilities can transform an ordinary microcomputer system into one of infinite magnitude. By introducing one Altair Floppy Disk System (88-DCDD), your 8800 series system acquires a mass storage capacity of 310,000 bytes per diskette.

The 88-DCDD includes a disk drive, controller, power supply, interconnect cable and case. Featuring a Pertec FD-400, the disk drive unit has direct drive dc motor operation which is insensitive to disrupting line frequency variations.

Up to 16 disk drives may be interfaced with the Altair Disk Controller. Consisting of two PC cards that plug into the Altair 8800 bus, the

Disk Controller regulates all mechanical operations and disk status.

Two software systems are available for the Altair Floppy Disk. Altair Disk BASIC offers the many features of Altair Extended BASIC plus increased program and data file load/save facilities. Our new DOS provides comprehensive tools for assembly language program development and disk file maintenance.

See the Altair Floppy Disk System along with the complete Altair product line at your local Altair Computer Center, or contact the factory for further information.



2450 Alamo SE Albuquerque, N.M. 87106

the recording scheme. Note that NRZ recording has a ratio of one. The third column gives the bandwidth requirements of the channel in terms of the "Ratio of the Maximum Frequency to the Minimum Frequency." The fourth column is whether a "Preamble" is required to provide read clock synchrony. A preamble is a known bit length and pattern appended to the front of each record. Generally, a preamble is required for all systems, but it may be only one bit long, as in biphase or ratio recording. Methods which do not provide a clock pulse for every bit require long, formalized preambles. Only long preambles have a "yes" in this column. The next two columns give the relative "Speed Tolerance" on both a bit-to-bit basis and on a long-term basis. Finally, the last column gives some additional comments.

Now let's look at each of these encoding schemes by itself and try to draw some conclusions about them. Fig 4 shows the encoded data stream for some of the encoding schemes of Fig 3 for an arbitrary 16 bits of data.

RZ recording starts out with unmagnetized tape (not such an easy requirement if one wants to reuse an already recorded tape) and simply goes positive for a one and negative for a zero, always returning to the demagnetized state between bits. The densities are relatively low, due to need to get back to zero between bits. The bandwidth requirements run roughly from 0.25 times the data rate to the data rate. RZ recording is particularly attractive for low density recording because it is virtually asynchronous, making minimal constraints on the density of the recorded data. RZ recording does not require a preamble.

S-NRZ recording is simply NRZ recording with an extra bit at every eight bits to provide a lower bound to the bandwidth requirements. Rather tricky electronics and buffering are required to squeeze an extra bit in for every eight in encoding and then clip it out again in decoding.

Bi-phase recording is a class of double frequency self-clocking schemes, many of which require no preamble and have a bandwidth requirement of only two to one. Bi-phase goes under many names, such as Manchester Code, Phase Encoding and Frequency Modulation. These are

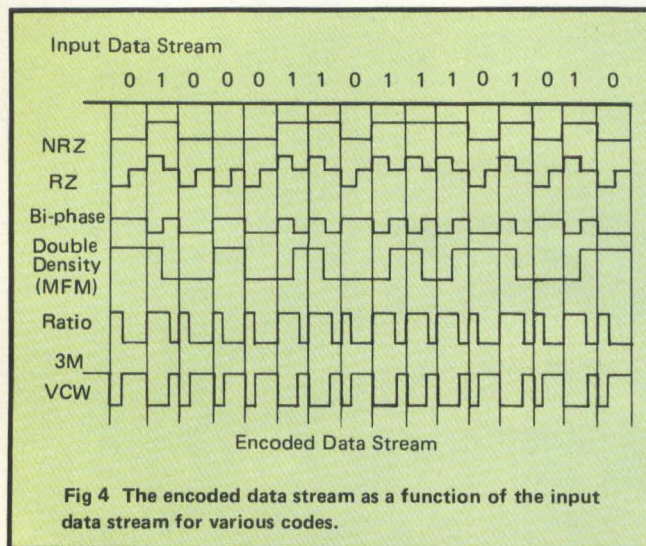

all essentially the same scheme in which a one bit is represented by two flux changes and a zero bit by one flux change. All the other schemes in this category are simply variations on this with inversions and phase shifts brought into play. All have essentially the same mathematical characteristics as far as the channel is concerned. Bi-phase (which I have elected to use as the generic name) generally has no dc component present and is relatively insensitive to small speed changes both on a bit-to-bit or over a long-term basis. Fancy electronics can take into account long term speed changes by simply altering the sampling clock rate to agree with the average bit cell.

Double density recording, used in various disk files, do not provide a clock bit for every data bit and thus requires a preamble to provide read clock synchronization. With the exception of ZM recording, discussed below, all double density schemes have dc present and are very sensitive to speed changes. Their bandwidth requirements, however, are equal to one-half the data rate.

Ratio recording is a relatively inefficient scheme, but one which has significant virtues for low cost systems. In ratio recording, a positive-going flux change at the leading bit cell edge always corresponds to a clock pulse while the position of the negative-going change (whether it is in the first half or the second half of the bit cell) determines the data. Since each bit cell stands alone, no preamble is required; a lost bit has no effect on adjacent bits as happens with double density and some bi-phase schemes. In addition, the speed tolerance is theoretically $\pm 50\%$ on a bit-to-bit basis and very high on a long term basis, limited only by the ability of the amplifier to provide sufficient gain for slow-moving tape or to handle the bandwidth requirements of rapidly-moving tape. You pay a price for this capability, however, in that there are essentially three flux changes per bit cell, thereby limiting the maximum recorded density. Detection is done by charging a capacitor (or turning on an up-counter) during the first portion of the cycle and then discharging the capacitor (or causing the counter to count downward) during the second part of the cycle. Since the capacitor is discharged at the end of each bit cell to start over again (or the counter reset to zero), the presence of dc in the detector is of no consequence.

Zero modulation or ZM recording was developed by IBM for their 3850 Honeycomb Mass Storage System. This is simply an algorithm of other double density schemes, but one which has zero dc component, thereby eliminating the accumulated unbalance between positive and negative pulse durations which cause baseline shift. This scheme is very sophisticated in terms of generating the encoded bit stream, since it requires an algorithm which looks both forward and backward in the data pattern, thereby requiring external memory. It is too sophisticated for simple cassette and cartridge tape systems.

Variable Cell Width, developed by 3M for use with their DC-100 transport, uses a combination of bi-phase and ratio recording. In this scheme, the bit cell length for a one is 50% longer than that for a zero. A zero is two pulses of opposite polarity for half the time, whereas for a one, the leading or

NCR's new portable bi-synchronous ASR terminal communicates at 2400 BAUD with an IBM 3270 (EBCDIC) data based system operating in a poll/select mode.

The 2000 character buffer permits communications at 2400 Baud with the computer. To transmit, inquiries are typed into the memory and held until polled by the computer, then transmitted at 2400 Baud. Requested information is transmitted back from a data based system at 2400 into the terminal memory. It is then printed out at 30 CPS. This greatly reduces the computer "On-Line" (connect) time.

NCR's new, fast, portable, bi-synch terminal em-t5

The terminal will have some edit capability while entering a message into memory and a capability for additional copies. Incoming messages will have priority and be received

into memory, except when the terminal is in the transmit mode (awaiting to be polled), or when the memory is full.

Messages will be printed out as soon as an (EOT) control signal is received into memory and the cyclic redundancy code (CRC) character is verified. Messages will remain in memory until replaced by another message or until the "clear-memory" button is activated.

To communicate with a computer, all that is needed is an electric outlet and a telephone jack. Set-up time takes only seconds. For immediate action, phone John Petry, Director of Marketing, at (607) 273-5310 or write Terminal Systems Division — Ithaca, P.O. Box 627, Ithaca, N.Y. 14850.



NCR

Terminal Systems Division — Ithaca

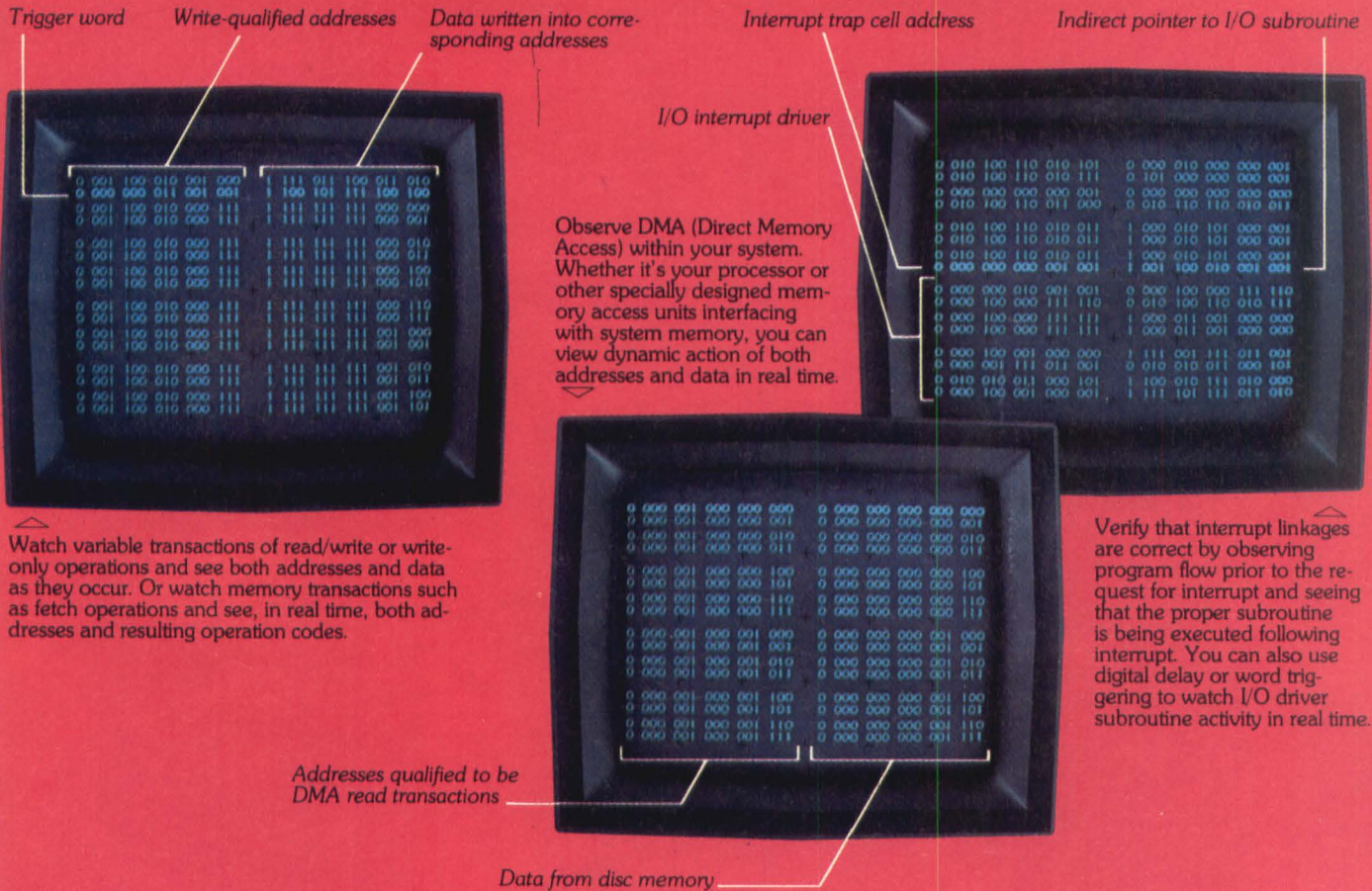

If you're designing minicomputer based systems, only HP Logic State Analyzers show you real time like this.

Logic State Analyzers effectively put you inside your operating minicomputer system for faster design and debugging. Here's the difference HP's real-time view makes.

HP's 1600S Logic State Analyzer (priced at \$7100*) plus 10254A Serial-to-Parallel Converter (priced at \$975*) gives you a better way to spot and diagnose intermittent system operation. They give you greater insight for better understanding of your system's capability. The combination can mean earlier product introduction, lower development costs, a faster return on the development investment.

Your local HP field engineer has all the technical details. Give him a call today. And also ask him about HP's FREE seminars—An Introduction to the Data Domain.

*Domestic U.S.A. prices only

Cursor
Dynamic real time photograph (time exposed) of incrementing counter used as system clock

Get a system overview with this memory map. It shows how your memory is being utilized in an operating program. If you know how your memory is organized, the map tells you at a glance what your program is doing and the relative time being spent in any one memory location. That makes it easy to spot things that shouldn't be happening, or to determine that part of your program isn't being implemented.

Disc address (cylinder, head, sector)

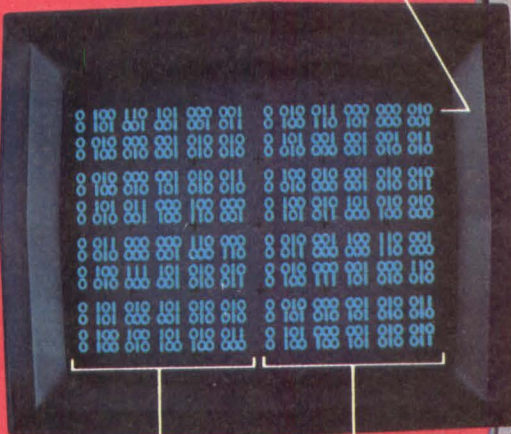

Parallel data inside computer

Serial data from 10254A

ASCII code

View I/O transactions in real time. Straddle an interface with the 1600S and you can evaluate handshake signals and compare input and output data directly—even if the clock rates differ and you're comparing serial data to parallel.

Qualifiers, digital delay and various local or bus-triggering modes give you pinpoint selection of data flow for effective program tracing.

Output triggers drive your scope—at the right instant—for making electrical measurements in the time domain.

Up to 32 channels let you see all the action on a 16-bit system main bus plus 16 bits in the control section, I/O, or any other logic section in your minicomputer system.

Dual clock means you can easily relate bus activity to events occurring elsewhere at a different clock rate—in system peripherals, for example.

Serial-to-Parallel Converter (HP's 10254A) lets you directly view serial data in relation to parallel data on the system bus.

FREE DATA DOMAIN SEMINAR

Find out for yourself how HP Logic State Analyzers can broaden your view of the data domain and speed digital design and debugging.

Seminars are scheduled in a number of cities throughout the country. Ask your HP field engineer about specific details on seminars in your area.

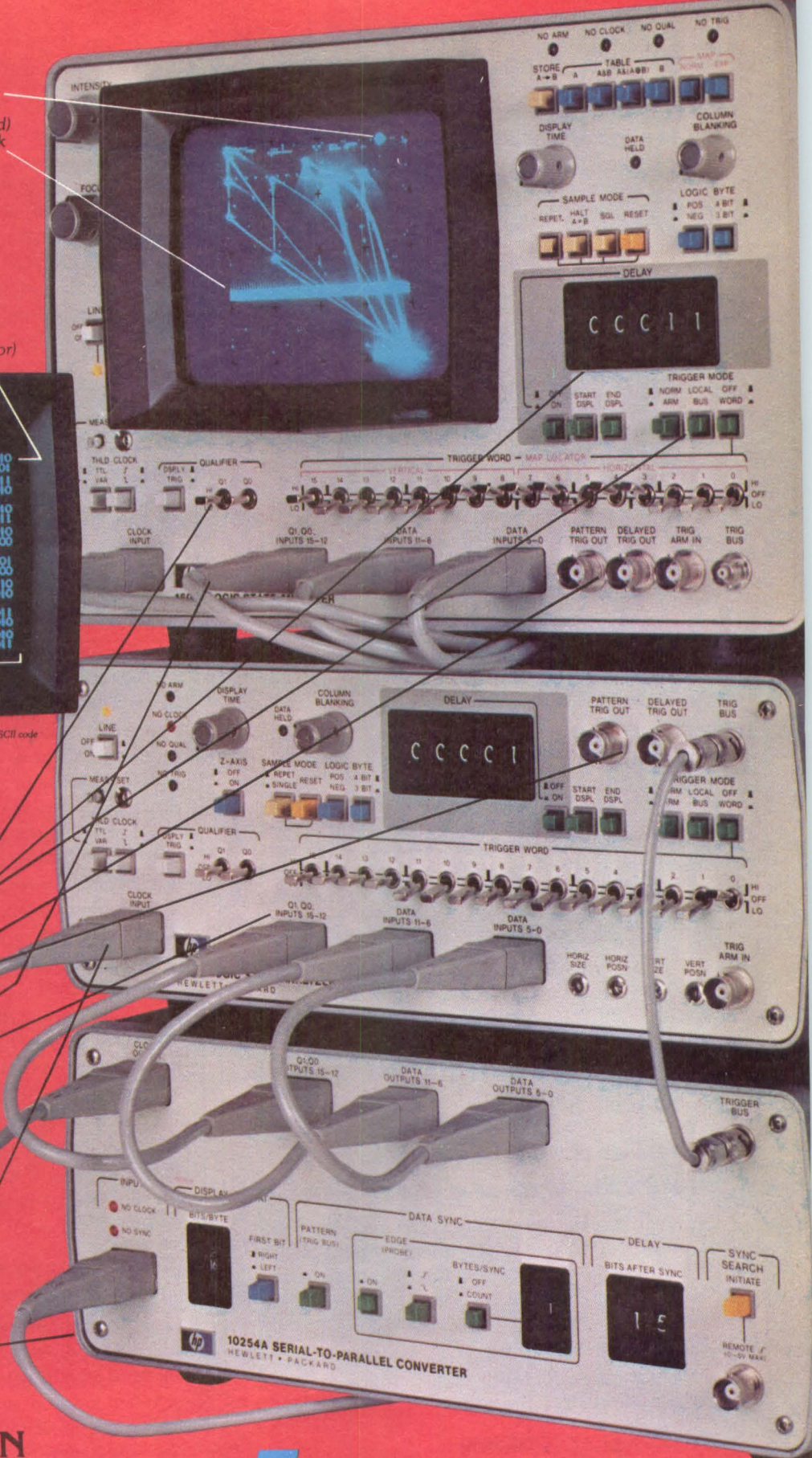

HEWLETT  PACKARD

1507 Page Mill Road, Palo Alto, California 94304

For assistance call: Washington (301) 948-6370, Chicago (312) 255-9800, Atlanta (404) 955-1500, Los Angeles (213) 877-1282

CIRCLE 26

New! Model 640 Low Cost* Loader Reads 350 Characters per Second

All solid state photo-electronic components.
Reads all standard 5,6,7 or 8 level tapes.
Smooth, quiet, AC drive.

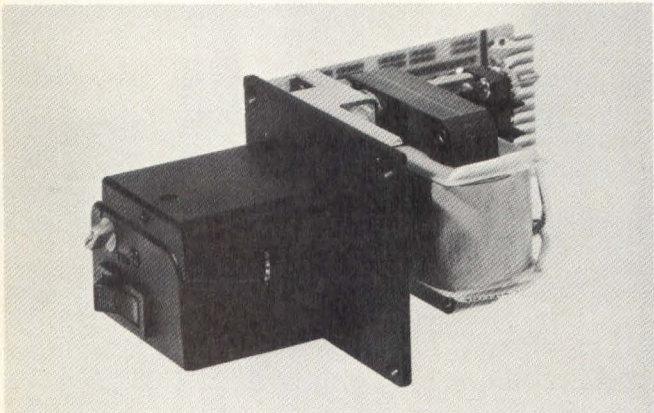

Provides reliable, high speed data entry. Data amplifiers and "character ready" output available for CMOS or TTL interfaces. Fanfold box available.

The Model 640 is the newest addition to the Addmaster line of quality paper tape equipment.

*Only \$166-189! (1-49 units; substantial quantity discounts available.)

Addmaster Corporation, 416 Junipero Serra Drive, San Gabriel, California 91776. Telephone: (213) 285 1121.

CIRCLE 27

FAIRCHILD

DIGITAL MAGNETIC RECORDING HEADS

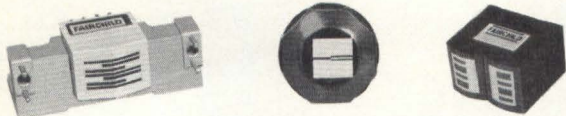

Got problems with your HEAD?

We can probably help. Our specialties are Digital Cartridge, Cassette and Floppy Disk Heads, all with ceramic/ferrite construction for extra long life and superior frequency response. Standard or special track configurations available.

Contact Mick Liddell, sales manager, for information and literature.

FAIRCHILD

WORLD MAGNETICS, INC. 810 HASTINGS STREET
A SUBSIDIARY OF FAIRCHILD CAMERA TRAVERSE CITY, MICHIGAN 49684
AND INSTRUMENT CORPORATION (616) 946-3800

CIRCLE 28

negative pulse is equal to the leading or negative pulse for the zero, but the positive pulse is twice as long.

what encoding scheme to use?

This is not an easy question to answer since it depends upon the following factors:

- Mechanical stability
- The nature of the data being recorded, and
- Whether one can use error-correcting codes.

The mechanical stability of the system includes such things as the need for interchangeability of tapes recorded on one machine to play on another, the accuracy and uniformity of tape speed and the mechanical rigidity of the tape-handling system to minimize structurally caused azimuth problems, etc. Apropos of the latter, the alignment between the gap in the playback head and the recorded data on the tape is very critical at high flux-change densities and requires the tape to pass over the head at a constant angle no matter what machine the tape is played on and no matter when and under what conditions. At high data densities, a slight azimuth misalignment of the tape with the head will cause a serious decrease in output and increased errors. Nonuniform tape speed requires the use of a speed-tolerant recording system such as ratio recording.

A second factor is the nature of the recorded data. Some of the encoding techniques require a preamble which must be appended to each record — expensive in terms of tape utilization if the records are short. Clearly, it is not any problem for a long, unformatted record since the preamble will represent only a minuscule fraction of the total record length. However, for short records, the requirement to append a preamble will cause an appreciable increase in the record length, thereby negating the gains made by going to a higher density recording scheme. In addition, the use of double density schemes on tape is particularly tricky, since they are virtually intolerant of any long term speed changes because their detection window is extremely narrow and difficult to change in concert with a change in data rate.

Finally, the use of error-correcting codes, either cyclic codes added on to fixed-length records or other more exotic codes, can provide automatic error correction in the decoding process itself. Again, the addition of error-correcting codes may or may not be required, depending upon what is to be done with the data. Most users find it sufficient to add a checksum at the end of a record in order to tell if the record has been received correctly by the decoder.

using a microprocessor to replace the encoder and decoder

Clearly, a microprocessor can be used to generate the encoded waveforms from the data stream, based on which encoding algorithm is required. The microprocessor can be run in interrupt mode during encoding, since the timing for writing the data is not critical. In playback, however, since the timing comes off the tape, the microprocessor must be dedicated to the reading of tape. If the system already has a microprocessor in it, then it may be easy to dedicate a small amount of the program to writing and reading tape, thereby saving the considerable expense of hardware implementation of encoding and decoding.

CIRCLE 29▶

Quality is known by the company it keeps



Quality is known by the company it keeps and here are eight reasons why COMPLØT® is outstanding in the field:

- | | | | |
|--------|-----------------------------------------------------------------------------|--------------|--------------------------------------------------------------------------------------|
| DP-101 | All-new microprocessor-controlled plotter—\$3495 | PTC-5A | The new Remote Time Share Plotter Controller—two models—\$1945 & \$2595 |
| DP-1 | Classic 11" wide plotter—\$3550 | BTC-7 Series | Adds inexpensive graphic output to the CDC 734 and Cyber 18-5 Batch Terminals—\$2595 |
| DP-11 | Our newest 11" wide plotter at speeds up to 4000 steps/sec.—\$3995 | MTR-4 | Magnetic Tape Reader/Controller \$15,500
1600 CPI Phase Encoded Model—\$19,950 |
| DP-3 | Plotting on a 22" wide surface at 400 steps—\$5150 | | |
| DP-8 | One pen or three, 36" wide, super quiet, three models from—\$7600 to \$9500 | | |

**houston
instrument**

**THE
RECORDER
COMPANY**

DIVISION OF BAUSCH & LOMB

ONE HOUSTON SQUARE (at 8500 Cameron Road) AUSTIN, TEXAS 78753

(512) 837-2820

TWX 910-874-2022

cable HOINCO

TELECOPIER

EUROPEAN OFFICE

Rochesterlaan 6 8240 Gistel Belgium
Phone 059/277445 Telex Bausch. 81399

® A registered trademark of Houston Instrument

US DOMESTIC PRICES ONLY

Plotters can be driven on-line, offline, time share or remote batch

Cassette, Cartridge and Diskette Drives

by George King

Designers usually base their choice of whether to use a cassette, cartridge or flexible disk drive on differences in stored information integrity, data storage capacity and speed of operation. Since manufacturers of all three systems are aggressively improving their products and making them more competitive, system engineers cannot automatically choose one type of drive over another because of its inherent characteristics. For example, cassette and cartridge drive vendors are trying to overcome the inherently faster access times offered by random access floppy disk drives by increasing tape speed or increasing the number of tracks for storing data.

The state-of-the-art is changing in a number of other ways, too. Manufacturers are adding more electronics to controllers and interfaces to make their drives more flexible. Many of them are offering drives in miniature versions. Consequently, a smaller, lighter, less expensive unit may be able to do the same work as a large standard size at a substantial savings in cost per bit.

These changes in technology makes your decision on which drive to use no longer quite so "obvious". It pays — in higher reliability, more design flexibility, larger number of options and substantial savings — for you to review the three types of drives to determine which one can handle the needs of your system most effectively.

cassette drives

The earliest of the three recording systems, the cassette drive, descended from the audio cassette, has hardly changed during the last five years, though improvements in reliability, operating speed and packing density characterize the newer units. Well established ECMA and ANSI standards have led to a level of product uniformity not shared by the other two types of drives. Almost all units use phase encoding to record data, written block by block and stored in serial form. In almost all instances, preamble and postamble are generated automatically at the start and end of each block. The typical packing density is 800 bits per inch (31.5 bits per mm.). Standard control functions usually include at least: write, stop, reverse, read on block, read continuously, check read one block, erase, rewind to beginning of tape (BOT), rewind for cassette removal.

Data flow checking is usually also automatic: read-after-write check (RAW); drop in and drop out check; bit timing check; cycle redundancy check (CRC) where two charac-

ters are recorded at the end of each data block and during RAW the CRC for the block is recalculated and compared; and parity checking of received data. A series of status functions also can include: no cassette inserted in unit; cassette compartment not closed; cassette improperly inserted; no power; whether or not the file is protected; and in two sided tape whether A or B is in position. Some units provide buffers and also variable tape speed for read/write and search.

The level of reliability for cassettes is high with a mean time before failure (MTBF) at a minimum of 5,000 hours; the encoded information, if reasonably protected from the environment, is reliable for over a year.

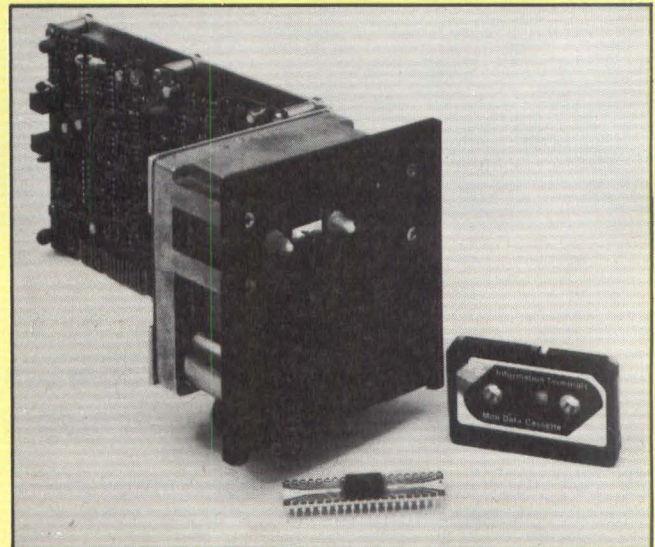

Model 6409 minicassette recorder from Raymond Engineering packs 64 kbytes of unformatted information onto each side of the tape.

Although many units use the simple mechanical drives typical of older audio cassette systems, there is a trend toward capstan and servo motor controlled drives, particularly as higher tape speeds and packing densities become more common. Undergoing a "mini" revolution, the minicassette has now reached the stage of proposed ANSI standards. These cassettes are used where size, weight, power consumption and cost are major considerations. Raymond Engineering, for example, introduced the Mini-Raycorder last year. Its small size, less than 17 cubic inches, makes it suitable for portable terminals, desk top calculators and portable test equipment. Power requirements are so low,

Table 1 — Capability Comparison Of Three Types Of Drives

Drive Parameters	Full-Size Cassette	Minicassette	Full-Size Cartridge	Minicartridge	Full-Size Diskette	Minidiskette
Unformatted Capacity (kilobytes)	720	64	2870	772	400 single density 800 double density	110 single density 220 double density
Tracks	2	1	1, 2 or 4	1 or 2	77	35
Heads	1	1	1	1	1	1
Data Transfer Rate (kbits/second)	24	2.4	48	24 or 48	250 single density 500 double density	125 single density 250 double density
Relative Velocity of Medium Over Head (inches/second)	30	3	30	30	120	80
Average Access Time (seconds)	20		20	11.2	0.286	0.566
Typical Drive Size (inches)	4 x 6 x 8	3 x 3 x 1.1	3 x 7 x 10	3 x 4 x 4.1 (4. x 5 x 4.5)	4.6 x 8.5 x 14.2	4 x 6 x 8
Typical Weight (pounds)	5	1	4	1 (3.2)	14	3
Typical Voltage Requirement (volts)	+12, -12, +5	+5	+18, -18, +5	+12, +5	+24, -15, +5	+12, -12, +5
Typical Drive Price (qty 1) Without Controller	\$750	\$260	\$850	\$250	\$600	\$390
Media Size (inches)	4 x 2.5 x 0.4	2 x 1.3 x 0.3	4 x 6 x 0.665	2.4 x 3.2 x 0.4	8" sq. envelope	5.25" sq. envelope
Media Price (qty 1)	\$8.00	\$7.70	\$18.00	\$14.00	\$6.50	\$4.50
Unformatted KBits/Dollar (Drive + Media)	7.6	1.9	26.5	23.4	5.3 single density 10.6 double density	2.2 single density 4.5 double density
Recording Density (bits per inch)	800	800	1600	800 or 1600	3200 single density 6400 double density	2580 single density 5160 double density

Note: These values for storage capabilities and approximate costs come from a typical drive of each type for storage. Although the numbers for other makes of drives may differ — sometimes significantly — from those listed, this table should help you narrow your choice to a couple of possible types to investigate intensively.

less than 1.5 watts at 5.0 volts, that it can be operated by battery. Like many of the newer units, it uses servo motor control for accurate tape tension and minimum head and tape wear. The unit stores 64K bytes/side unformatted with a data transfer rate of 2400 bits per second and an 800 packing density. Tape speed is from 3 to 20 ips.

The move toward miniaturization has produced two unusual transports, each of which uses a different type of tape package. Although neither the MicroVox Wafer by Micro Communications nor the Unireel by Interdyne truly fall into the cassette category, we have included them here for convenience sake.

The MicroVox wafer is a very small, thin, continuous loop cartridge. It contains a single reel of tape available from 5 to 50 feet in length (in 5 foot increments) with a tape width of 0.07 inch. At maximum length it stores 1.44 million flux changes at 2400 fci. Its mylar tape is coated with a low-head-friction dispersion of chromium dioxide instead of the more standard ferric oxide. All digital wafers are certified for no errors at 2400 fci. The software inter-

face systems are available in three configurations: write only, read-write, and hybrid read-write, which can be ordered at two tape speeds 1.5 ips and 3 ips. The MicroVox Wafer drive costs \$150 to \$200 in OEM quantities.

The Unireel is a single cylindrical reel of magnetic tape. It measures 2-1/8th inches (84 mm.) in diameter. The companion small, self-threading tape drive, according to the manufacturer, achieves the simplicity, reliability and low cost of single motor cartridge drives. It is loaded with 150 feet of computer grade tape 0.150 inch (3.81 mm) wide, certified at 1600 fci. Its formatted capacity is approximately 140,000 bytes at a recording density of 800 bpi. The simplicity of transport contributes to a calculated MTBF of 12,000 hours for drive and electronics. Accidental loss of one or more power supplies will not cause tape damage or spills under any operating mode. Internal logic prevents accidental tape run-off. The Unireel drive costs from \$100-150 in OEM quantities.

Units with 2- or 4-track capabilities can provide higher data density per unit length of tape. Some current state-of-

Economical Digital Cassette Recorder for Data Capture and Preparation

Based on the success of their digital cassette recorder, DCR 1, Philips is introducing a new range of digital cassette recording systems that comply with the relevant ECMA standards governing magnetic tape cassettes parameters and the methods of recording, replaying and file structuring. The new range gives original equipment manufacturers and end users a choice of ready made solutions to a wide variety of data collection and data preparation applications.

Market trends show that there is an increasing need for a low cost data storage medium offering serial registration without random access. It is the claim of Philips that their digital cassette technology offers the best cost-to-performance ratio of any such interchange storage medium available today. Philips are convinced that the cassette medium will now become a more attractive alternative to such media as paper tape, punched cards and cartridge due to the convenience of handling, the compliance with ECMA standards and the low price.

The range comprises the DCR 3 digital cassette recorder which is also available without electronics and known as the DCT 3, two versions of the DCR 4 digital cassette

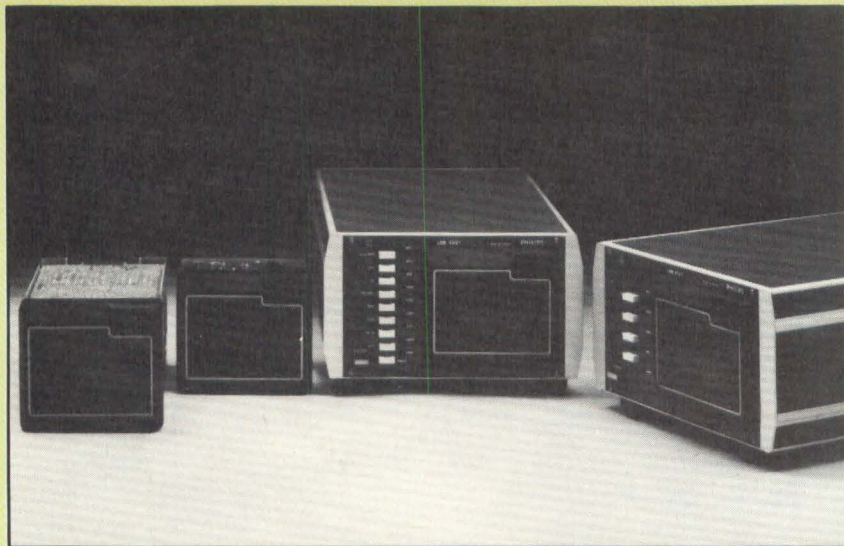

recorder and two intelligent cassette terminals, types LDB 4101 and LDB 4201.

The DCR 3 succeeds the DCR 1 and can be used, at minimum initial cost, in all original equipment at present utilizing the DCR 1. It is a data capture device for small business machines, visible record computers and high grade terminals. The DCR 4 is a low cost, uni-directional drive system available in a write-only version (data collection for statistical purposes) and a read-after-write version (higher data integrity). CMOS electronics ensure low power consumption. To cater to OEMs wishing to integrate the Philips drive assembly into a system of their own design, the DCT 3 pro-

vides a quality cassette transport.

Data logging requirements met in applications like electronic cash registers and automatic test and measuring systems can be solved with the LDB 4101. This write-only cassette system is available in FACIT 4070-compatible and serial interface (RS 232C) versions.

The LDB 4201 is a read-after-write cassette input system available in serial, current and parallel interface versions. Higher data integrity through an error correction system together with micro-processor control permit the LDB 4201 to be used in on-line and off-line data entry and data preparation applications. Philips, P.O. Box 523, Eindhoven, The Netherlands. **Circle 149**

the-art drives also operate at fairly short access times. For example, Tape II by Lexitron Corp. is challenging floppy disk drives in density and transfer speeds. According to Lexitron President Richard O. Bailey, the four track cassettes contain 508 square inches of usable storage surface, compared to 38 square inches for the standard floppy disk, and can transfer a full page of text to the video display screen in one-half second. Access time is slower than for a floppy disk, but Lexitron claims that in heavy word processing applications the format, density and transfer speeds make actual document production highly competitive.

Increasingly, manufacturers are attempting to reduce the complexity of interfacing cassette drives with the CPU by including interface electronics. A typical manufacturer may supply an equal number (most commonly eight) of data input and output lines with strobe and a separate line for rewind, plus several other lines — all TTL-compatible. This interface eliminates the user's concern with such transport functions as start and stop time, leader length, encoding/decoding and the need for external clocking. Self-clocking provides speed tolerant recording, according to Electronic Processors, claiming that it essentially eliminates effects of flutter, wow and head misalignment — three problems nor-

mally associated with low-cost digital cassette drives. As a result, transports so equipped commit less than 1×10^7 soft errors and less than 1×10^8 hard errors.

Designers appear to be discovering an increasing number of applications for cassette drives, many of which were first introduced to replace paper tape units. Jack Morros, application engineering technician for Triple I believes that in the next two to three years cassette drives will expand even more into microprocessor loading applications, such as data logging and analysis, storage for microprocessor development systems and portable program loaders. He also believes that the use of microprocessors for control of transport functions, data encoding and formatting, and interfacing will expand.

Kevin M. Corbett, marketing manager of Memodyne Corp., reports that "new applications are arriving every day" and notes that Memodyne's equipment is used in low power recording devices for such functions as measurement and collection of temperature, pressure, air purity, water purity and seismic information; recording parameters of engine performance on trucks, buses, trains and automobiles; keyboard to cassette storage; external memory for minicomputers; collecting data for billing and point of sales machines; program minicom-

puters and desk top calculators, machine and process control tools; input/output storage for data communications; inventory control systems; and computer peripheral memory.

cartridge drives

The need for higher operating speeds and greater storage capacity than available from cassette drives led to the development of the data cartridge. Typical cartridges contain 1/4-inch wide by 300-foot long high-performance magnetic tape capable of recording 1600 bpi on up to 4 tracks. For example, 3M specifies its cartridges as capable of operating between 0 and 90 ips. Holes in the tape provide light passages for optical sensing of BOT, load point, early warning and EOT. All cartridges have a file protect mechanism. Most tape transports use capstan drives.

Just as with cassettes, cartridge drive manufacturers are expanding the data storage capacity of their equipment. Sycor has developed a 440 system option specifically dedicated to providing a low cost dump/restore medium for fixed disk storage. It utilizes a 3M-type cartridge. Special stand-alone dump-restore utilities operate from a pre-established common file or from a single RUN command. With a capacity of 5.76 Mbytes, it can dump 5 Mbytes of disk storage in 7 minutes. The unit uses a double-density

encoding technique and a phase-locked loop data separator to achieve 3200 double ANSI density. Data is recorded in a continuous, unformatted stream at 60 ips. No time is lost by the usual stop-start operation, because the data is written unformatted at 2048 byte records with a CRC (cyclic redundancy code) checking polynomial at a data rate of 24 Kbytes per second.

In another approach to increasing the data capability of a cartridge unit, National Computer Systems has developed a cartridge carousel system that houses 16 quarter inch tape cartridges in a removable pack. The pack mounts on a drive unit containing one to four read/write stations, operating mechanism and logic circuitry. Cartridges are loaded processed and unloaded at the nearest available station and all four stations can be in operation at the same time. Dual I/O ports and two 8080 microprocessors in the logic circuitry simplify computer to peripheral interfaces. While the cost of the carousel about equals that for floppy disk drives, the system stores 112 times more than a 250K floppy. One cartridge holds 1,814,528 bytes of 512-byte records.

Recording density. Many cartridge drive applications require maximum data storage per cartridge. Serial recording fundamentally offers a higher packing density than parallel recording. Block size is the most significant factor for determining packing density.

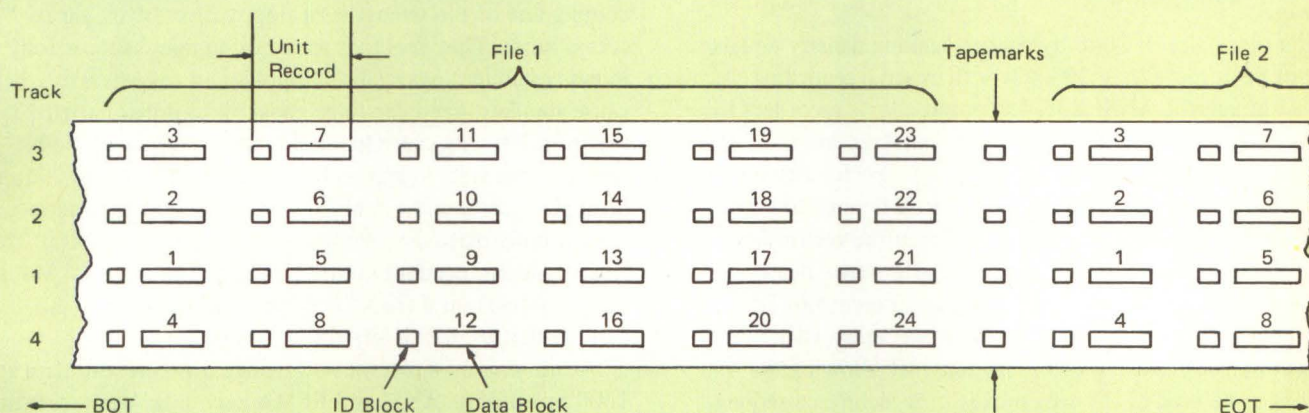

Interdependent Track Operation

A cartridge recorder with interdependent track operation can file data on all 4 tracks, because of wide tolerance allowances. It does not require a change-of-track algorithm.

Interdependent track operation must follow these rules:

- * A "write unit record" command generates the ID and data block, that can only exist as a unit record.
- * A "rewrite data block" command updates or rewrites a data block as required, but the ID block is not normally erased or rewritten.
- * If the ID or data block cannot be written, a reverse and a forward space over the last good record must precede a rewrite attempt on an erase operation.
- * When erasing a unit record because the ID and data block cannot be written in the space provided, an "erase a gap" command, started at the gap before the bad record, deletes the entire record from this area on the tape. (Positioning in this gap should observe the preceding rule).

* If tape marks are used to signify the end of a data file, then 4 recorded tapemarks across the tape prevent inadvertent movement into a new file on each track.

* Track 1 is assumed to be the physical tape reference location of the other 3 unit records or tapemarks in each specific group of 4.

operational example

A typical task performed by a formatter system involves locating a specific unit record in a set of cartridges, just inserted into the drive, and updating that unit record. Knowing the file number, file size and record number, the system first searches by mark count to locate the specific file. Then searching by block count, the system uses the record number divided by 4 to position the tape quickly to within a few records of the one required. A "read ID block" command provides further information for positioning to the correct track and unit record, which the system can access and update.

For 1/4" wide 4-track tapes recorded serially, the ANSI Proposed Standard X3B/44 defines the byte as 8 bits, preamble and postamble as 16 bits, CRCC (cyclic redundancy checking code) as 16 bits, IRG (interrecord gap) as 1.2" minimum, density as 1600 bpi track or 200 bytes/inch/-track and tape length as 3600" minimum. Maximum cartridge capacity equals $200 \times 3600 \times 4 = 2.88 \times 10^6$ bytes. If the linear overhead/block equals 48 bits or 6 bytes and $N = \text{bytes/block}$, then packing density in percent,

$$d = 100 \times [N/200] \div [N/200 + 6/200 + 1.2]$$

Then the maximum number of bytes,

$$B_{\max} = 100N/(N + 246) = 2.88 \times 10^6 [N/(N + 246)]$$

For the minimum ANSI block size of 6 bytes, the packing density approximates 4%; for the maximum ANSI block of 2048 bytes, about 90%.

For parallel recording on the same cartridge, the following definitions apply: frame = 1/2 byte or 4 bits across the tape; byte = 8 bits or 2 frames; preamble and postamble = 16 bits linearly; CRCC = 16 bits or 4 frames or 2 bytes; IRG = 1.2"; density = 1600 bpi/track or 6400 bpi or 800 bytes/inch; and length of tape = 3600". If the linear overhead/block = 36 bits, then the packing density in percent,

$$d = 100 \times [N/800] \div [N/800 + 36/1600 + 1.2]$$

Thus, the total number of parallel-recorded bytes,

$$B_{\max} = 100N/(N + 978) = 2.88 \times 10^6 [N/(N + 978)]$$

For a block size of 2048 bytes, the packing density equals about 68%, more than 20% lower than serial recording.

Although the ANSI X3B/44 format allows recorders to store more data on each cartridge, parallel recording on the 4 tracks is faster, because rewinding the tape for accessing each track takes nearly 40 sec and search time is slow, too. If the cartridge drive were to use a serpentine recording pattern, it would need an exotic read-after-write head.

Data Electronics has developed a serial recording technique based on interdependent track operation. (See nearby box for an explanation of the format.) By allowing the 4 tracks to be used as the tape moves, this technique sequentially records unit records across the tracks as the file fills up with data. The recorder can then use a RAW head and, in effect, create a continuous, yet sequential, record file, accessible in less than 1/4th the time and easily overwriteable. Recorders with this capability are suited for transaction-oriented applications, such as point-of-sale, data logging and business machines.

Four-track parallel recording provides two important advantages: high data transfer rate and low search time. Operating at 30 ips, a parallel track recorder can transfer up to 192 Kbits/s; a serial recorder, only 48 Kbits/s. The high rate makes 4-track parallel machines more suitable for such ap-

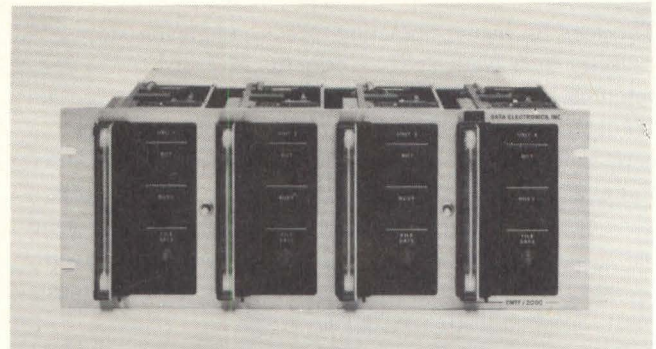

Four 6400 BPI cartridge drives, mounted in a Data Electronics CMTF-2000 Series formatter that occupies a 7" panel space, can record on-line up to 46 Mbytes at 24 Kbytes/s.

plications as program loading and disk back-up. Data Electronics has recently placed a unit with a 6400 BPI recording density. This drive sells for approximately one-third more than the company's 1600-BPI unit, but has 4 times the capacity — 11.5 Mbytes unformatted.

Cartridge drive manufacturers are working hard at overcoming one of the strengths of floppy disk drives, short access times. They feel that they can compete successfully in many applications against floppies and cassettes, too, because standard-sized cartridge capacity of unformatted 23 Mbits on 4 tracks exceeds the number of unformatted bits recorded per side on standard-sized (8") diskettes (3.2 Mbits in single density and 6.4 Mbits in double density) and recorded unformatted on Philips-type cassettes (2 Mbits). The recently-introduced miniature cartridge can store 1.4 Mbits (unformatted) on 4 tracks and the first recorders to use 5-1/4" diskettes, 875 Kbits/side.

At the present time, most cartridge drives record data at 1600 bpi and use ANSI and ECMA encoding. Very recently a recorder with 3200-bpi rate has been introduced. If this equipment should prove its cost effectiveness in the field, Herm Brooks of Tandberg Data said that most cartridge drive manufacturers would offer similar high-speed models.

At the present time, head technology, mechanical wear and magnetic problems limit cartridge search speed to 30 ips. Research and development work will make a 60-ips

Table 1 Typical Performances for Cassette, Cartridge and Diskette Drives

	Cassette	Mini-cassette	Cartridge	Mini-cartridge	Diskette	Minidiskette
Storage Capacity/Size (Kilobytes)	360/track	60/track	2048/track	336/track	243,400,800	80,125,250
Data Transfer Rate (Kilobits/sec)	12.8	16	48	24, 48	250, 500	125, 250
Random Ave. Access Time (sec)	36	11.2	20	11.2	0.26	0.37
Soft Errors	1×10^7	1×10^7	1×10^8	1×10^8	1×10^9	1×10^9



Carousell 5200, marketed by National Computer Systems, holds up to 16 full-size cartridges for recording digital data.

speed possible in 2-3 years, predicted an industry spokesman. Beyond that point, problems increase exponentially.

The minicartridge, the 3M-developed shirt pocket version of the full-sized cartridge, contains 140 feet of 0.150-inch tape in a package measuring 2.4 x 3.2 x 0.5 inches. Qantex has developed a MINIDRIVE, a highly compact unit 3 x 4 x 4.125 inches, weighing one pound to use the miniature cartridge. The transport uses a servo loop that includes a solid state optical tachometer for precise speed control of the low inertia DC motor. The MINIDRIVE, available with 800 bpi or optional 1600 bpi packing density, transfers 24,000 or 48,000 bps at a tape speed of 30 inches per second. Storage capacity of from 168,000 to 772,000 depends on packing density and number of tracks.

Applications. Unattended data logging is the prime application area for cartridge drives, particularly in harsh environments, where dust, dirt, heat and cold are problems.

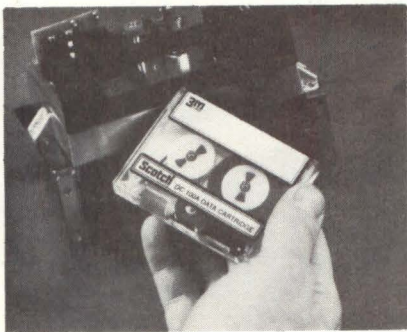

Intended for point-of-sale terminals, automatic typewriters and similar equipment in which size is critical, the DCD-1 data recorder, manufactured by 3M, uses a minicartridge, slightly smaller than a standard Philips-type cassette.

Citing the high reliability of the cartridge and the recorder, Herm Brooks said that the medium fails before the recorder, does; he stressed that most high-volume data logging operations usually cannot permit too many errors to occur. For example, a system that monitors a chemical plant operation could create hazardous conditions, if the logger erred too often.

Other applications of data cartridge drives include: replacement for paper tape punch/reader; memory loader for an onboard computer system; numerical control machine tools; hand-held text computer; small business OEM system; program and data storage with microcomputer system. Mohawk Data Sciences projects such contemplated applications as a data logger for the telephone industry recording origin/destination and length of calls, a logging device on toll roads recording car types, toll amounts and average distances traveled, and for the printing industry which is beginning to use magnetic tape control of press operations.

Interfacing a recorder with a minicomputer requires the drive to conform with the computer's handshaking rules and protocol. However, if every make of mini or micro were equipped with an RS-232C interface, then the interface problem would disappear for many makes of recorders. The lack of a commitment to this standard means that the user or the supplier of the recorder must supply a special interface for the computer in the system.

Cartridge drive manufacturers solve the interface problems in a number of different ways. In one typical solution, Tandberg Data designed its controller/interface to connect its cartridge recorder specifically with 8080 microprocessors and at the same time make it compatible with other types of microprocessors. Capable of handling up to four drives in a daisy chain, the interface contains all the normal for-

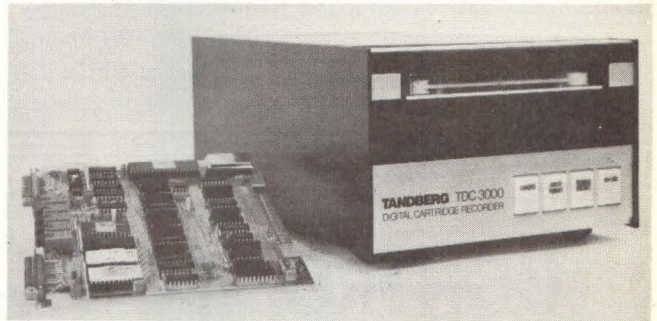

Tandberg Data TDC 3000 cartridge recorder, shown with RS-232C I/O controller card removed from its normal internal position, internal position, interfaces with most communication computer systems.

mating functions plus the interface logic for the processor bus to eliminate the need for a separate formatter. Data transfer takes place with direct memory access. The interface performs such functions as decoding, tape motion control, generation of proper block gaps, writing and reading of data, automatic generation of tape marks, high-speed search. Data transfer on the processor bus is under DMA control. The controller generates the proper memory address based upon an assigned start address. Two 4K PROMs store the program. The instruction set contains an edit function that permits the user to update the last block read automatically without overwriting the preceding or following blocks. During read or read-after-write, the microprocessor calculates and checks CRC characters.

flexible disk drives

Many applications cannot tolerate the long access time that serial storage of cassette and cartridge drives provide. Nor can they stand the high cost of random-accessible large rigid disk drives that provide short access times. One of the first companies to solve these two problems, IBM developed a

low-cost flexible disk and transport to allow random high-speed access to recorded data. The IBM unit proved so successful that it became the accepted standard for the industry. And IBM-compatibility became the goal of all floppy disk drive manufacturers. They accepted IBM's Diskette OEM's Information Manual, GA21-9190-2, as the standard. ANSI standards under development for diskette drives are also based on this manual.

Each standard-sized diskette consists of a 0.003-inch thick oxide-coated mylar disk permanently captured in an 8-inch square jacket. Openings in the jacket provide head and index hole access plus drive spindle-mounting. At the present time, IBM-compatible drives record on one surface only and rotate at 360 rpm.

The system records data serially on diskettes with 77 concentric tracks; numbering starts with 00 on the outside track and ends up with 76 on the inside track. Each track consists of 26 sectors, numbered 01 to 26, whose locations are pre-recorded on the floppy. Index track 00 contains information about data labels, the system and the diskette. Since two tracks are assigned as alternates and one as a space, 73 tracks are used to record data. The system writes data in 128-byte records (one sector), or a total $73 \times 26 \times 128 = 242,944$ bytes/diskette. In addition to data, each sector contains ID, track and sector number, and CRC information.

Bit density requires 13,262 flux transitions/radian. Recording technique uses double frequency, most significant bit first. Users can expect 1×10^9 soft errors (nominal) and 1×10^{12} hard errors (nominal). Transfer rate is 31,250 bytes/sec.

A typical IBM-compatible diskette recorder, such as those available from Applied Data Communications, provide a track-to-track step time of 10 ms and a settling time of 10 ms. Average latency is 83 ms and head loading time is 50 ms. Head life expectancy is 3 years and the oxide medium should withstand 200,000 passes in contact with the head.

IBM-compatibility constraint. Just after manufacturers had begun marketing IBM-compatible diskette transports, system designers started asking for recorders with greater storage capacity on each disk. To satisfy this demand, floppy disk drive manufacturers developed a number of encoding techniques and increased track density — none of which are IBM-compatible. As a matter of fact, almost none of the non-IBM-compatible transports available from various manufacturers are compatible with each other. (See the nearby boxed item for a discussion of flexible disk recording.) And as expected, recording on both sides of the diskette doubles the storage capacity without destroying IBM-compatibility. At the present time, a small number of manufacturers have introduced two-side diskette transports.

Minidiskettes. Manufacturers of standard-sized floppy disk drives found that many applications could not justify the cost of their transports, yet required the fast access of this type of equipment. This need led to the development of the minifloppy drive. In the effort to reduce the cost of the drives but keep equipment reliability high, various manufacturers developed some interesting mechanisms, particularly in the methods of stepping the heads across the tracks.

Resembling a full-size diskette, the minidiskette is per-

CONTROLLED SAVINGS!

**New fanfold tape reader
with attached controller
— all for less than \$1300**



53 John Street, Cumberland, R. I. 02864
Phone: (401) 724-8500 TWX 710-387-1171

Our model 2100 equipped with a controller is one of the best values in paper tape readers today. It's both hardware and software compatible with Digital Equipment's PDP 8 and PDP 11 as well as Data General's Nova 2, 3 and 1200. The Model 2100 gives you something extra: a unique power conservation system which reduces motor operating temperature. Write or call for additional information.

DIGITRONICS
Comtec Information Systems, Inc.

CIRCLE 32

Quick Change Artist.

**Our OEM 600 lpm printer
has a replaceable character cartridge
as fast and easy to change as a typewriter ribbon.**

How fast?

Less than a minute.

How easy?

Easy enough for anyone with the strength to pick up 10 lbs. and the skill to change a typewriter ribbon.

Data 100 knows what an OEM wants in a line printer.

Like fast and easy

character set interchangeability.

A capability that's standard on our 600 lpm printer.

It not only gives the user greater flexibility, but also eliminates the need to buy two line printers just to satisfy that requirement.

Make good sense to you?

It should. We're adding

this Quick Change Printer to our Data 100 systems, too.

DATA 100
CORPORATION

**Data 100 knows
what an OEM wants
in a line printer.**

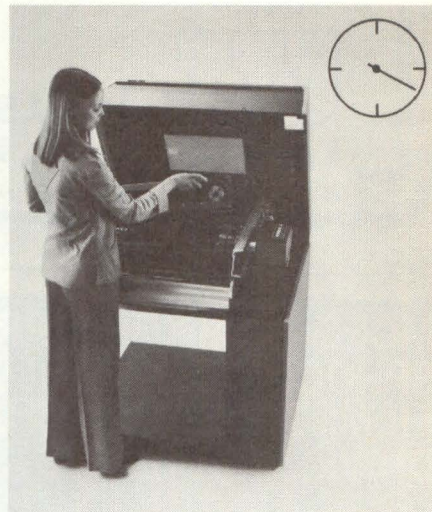
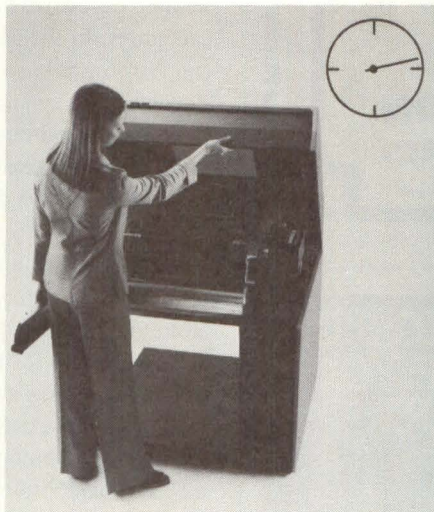
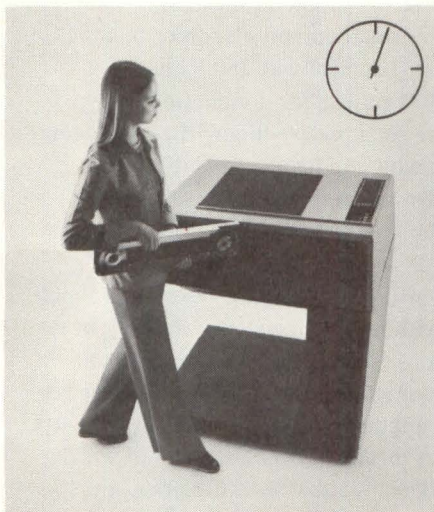

NEWPORT BEACH CA (714) 549-0982 • SANTA CLARA CA (408) 732-1530 •
BRAINTREE MA (617) 848-6100 • SOUTHFIELD MI (313) 358-3984 • EDINA MN (612) 941-6500 •
CHERRY HILL NJ (609) 665-5141 • WOODBRIDGE NJ (201) 634-7800 • HOUSTON TX (713) 777-4413 •
McLEAN VA (703) 790-5560 • TORONTO CANADA (distributor) (416) 495-0222 •
HEMEL HEMPSTEAD ENGLAND (0442) 66511 • BRUSSELS BELGIUM 251-69-72 •
FRANKFURT GERMANY 72-04-71 • PARIS FRANCE 630-2144 • MILAN ITALY (02) 659-52-32.

SEE US AT BOOTH 1315 NCC
CIRCLE 33



**SUPER BRIGHT
TAPE AND DISC DRIVE
EXERCISERS**

From the largest independent maker of Disc and Tape Drive Exercisers, you get the most complete, most advanced line of universal testers. For Incoming Inspection Production Test Field Service. Send for our comprehensive literature and price list.



**WILSON
Laboratories, Inc.**

2536 Fender, Fullerton, CA 92631 • (714) 992-0410

CIRCLE 34

MORE THAN 385 PRECISION SPROCKETS TO SOLVE YOUR FILM, TAPE AND CHART DRIVE PROBLEMS

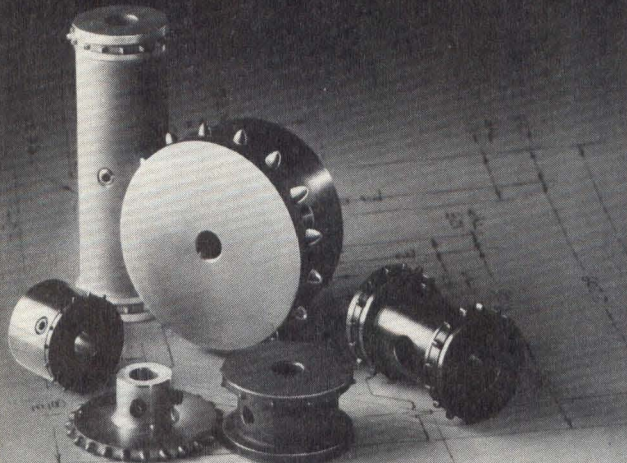

Drives perforated media with unvarying accuracy. Maintains media integrity. Standard sizes from 5mm to 105mm diameter, from 1/4" to 4", specials to 9". Aluminum, steel, stainless, and molded plastic. Geneva starwheel and drives.

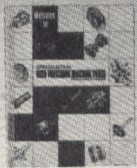

Our catalog tells all.

LaVezzi machine works, inc.

900 N. Larch Ave. • Elmhurst, Ill. 60126 • (312) 832-8990

CIRCLE 35

manently housed in an envelope measuring 5.25 inches square with the necessary apertures for drive spindle, head and sector hole access. For soft-sectored applications, the user may initialize the surface in any desired format, but the usual format usually consists of 128 bytes/record and 18 records/track. For hard-sectored applications, the user may employ diskettes with 16 sector holes, plus an index hole. Minidiskettes are available with 35 and 40 tracks. Typical capacities for unformatted (FM encoding) data approximates 100 Kbytes; for 40-track surfaces and initialized (FM encoding) data, 80 Kbytes on 18-sector tracks. Typical capacities for double density recording with data encoded in MFM or M² FM on 40 tracks is about 250 Kbytes. However, as noted in the May, 1977 issue of this magazine on page 82, Micropolis is marketing a minidiskette drive that stores 315 Kbytes of data on 77 tracks. Track density and flux change density determine the mini-floppy drive transfer rate. At the present time, rates of 125, 250 and 500 Kbits/sec at rotational speed of 300 rpm are available.

Interfacing. Characteristic differences between microcomputers and minicomputers divide full-size and mini flexible disk drive interfacing problems into two different categories. In the case of microcomputers, diskette drives can transfer data so fast — typically at 250 Kbits/s for single-frequency and 500 Kbits/s for double-frequency recording — and require such precise timing that microcomputers cannot keep up with and handle the bit stream. Therefore, system designers must decide how to get the data into and out of the processor and how to control the drive. They must also decide to what use they are going to put the disk-stored information. If the system is a stand-alone that interfaces with no other systems, close by or far away, then the format of the stored data is not critical, because the disks are not expected to be read on other systems. However, many applications require that the diskette be read by a number of different systems, some of which may not be completely compatible with the original recording equipment. In such applications, the floppy drive must record the data in a format common to all the systems expected to make use of the recorded information.

Since the only standard format that exists is the so-called IBM 3760 for single density recording, system designers often opt for it. In such cases, a designer can exercise 3 options: he can build his own controller/formatter with the latest LSI chips, or with older MSI devices; or he can buy his units from a company marketing them; or he can buy flexible disk drives with a built-in controller/formatter. Only a manufacturer who expects to sell large numbers of systems can economically justify designing and building his own controller/formatters. Even when he uses an LSI single chip in his design, the manufacturer must incorporate about 30 supporting IC devices and write a program more than one thousand words long to run the LSI device. According to one industry spokesman, it takes a large amount of expertise to design, write software for, debug and test a controller/formatter. Claiming that relatively few floppy disk drive makers build their own controllers, he said that microcomputer system OEMs quite often design the controller, because they can tailor it to exact rather than general-purpose specifications.

CIRCLE 36 ►

TEXAS INSTRUMENTS.

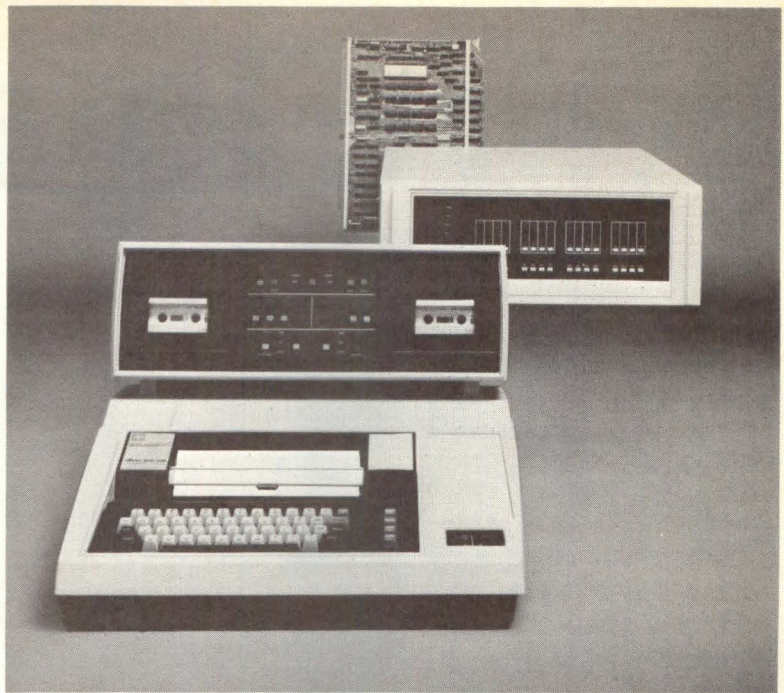

**The *Silent 700*
Model 733 ASR
twin-cassette
data terminal.
Big systems performance
at a small systems price.**

As a small systems peripheral and I/O console, the *Silent 700*[†] model 733 ASR offers the best price/performance value in the industry today.

Consider how these hard-to-match features can boost the cost-effectiveness of your minicomputer or micro-processor system.

Cassette Input

Along with proven *Silent 700* features such as 30-cps printing, virtual quietness and reliability, the 733 ASR offers twin tape cassette drives for low-cost data storage, software loading and off-line data editing.

Typically, you can store up to 288,000 characters per two-track cassette.

Data Editing

Additionally, you can use block or character editing combined with high-speed tape duplicating and fast file search.

[†]Trademark of Texas Instruments.

Binary Object Output

A binary data option allows output of 8-bit binary object code onto cassettes after source code assembly.

A Small Systems Price

The Model 733 ASR lists for \$3045* quantity one including printer and twin cassettes. The OEM's price is even more attractive.

You can pay less but would get a lot less. You can also pay more. But why do it when you have storage, editing, printing and keyboard all in one attractive package at an affordable price?

To arrange a demonstration with your system call your nearest TI office listed below. Or write Texas Instruments Incorporated, P. O. Box 1444, M/S 784, Houston, Texas 77001. Or call Terminal Marketing at (713) 494-5115, extension 2124.

*U.S. domestic price.



See Texas Instruments products at Computer Caravan and NCC.

**TEXAS INSTRUMENTS
INCORPORATED**

Arlington, VA (703) 527-2800 • Atlanta, GA (404) 458-7791 • Boston, MA (617) 890-7400 • Charlotte, NC (704) 527-0930 • Chicago, IL (312) 671-0300 • Clark, NJ (201) 574-9800 • Cleveland, OH (216) 464-2990 • Costa Mesa, CA (714) 540-7311 • Dallas, TX (214) 238-5318 • Dayton, OH (513) 253-6128 • Denver, CO (303) 751-1780 • Detroit, MI (313) 353-0830 • El Segundo, CA (213) 973-2571 • Ft. Lauderdale, FL (305) 733-3300 • Hamden, CT (203) 281-0074 • Houston, TX (713) 776-6511 • Indianapolis, IN (317) 248-8555 • Kansas City, MO (816) 523-2500 • Memphis, TN (901) 396-2410 • Milwaukee, WI (414) 475-1690 • Minneapolis, MN (612) 835-5711 • Mobile, AL (205) 471-1435 • New York, NY (212) 246-6165 • Orlando, FL (305) 644-3535 • Philadelphia, PA (215) 628-3434 • Phoenix, AZ (602) 249-1313 • Pittsburgh, PA (412) 771-8550 • Rochester, NY (716) 461-1800 • San Antonio, TX (512) 828-9101 • San Francisco, CA (415) 392-0229 • Seattle, WA (206) 455-1711 • St. Louis, MO (314) 569-0801 • Sunnyvale, CA (408) 732-1840 • Tulsa, OK (918) 437-7904 • Amstelveen, Holland 020/473 391 • Bedford, England 0234-67466 • Brussels, Belgium 733.96.24 • Cheshire, England 061-442-8448 • Copenhagen, Denmark 01/91.74.00 • Essen, Germany 0201/20916 • Frankfurt, Germany 0611/39/90.61 • Freising, Germany 08161/7411 • Helsinki, Finland 90-408 300 • Lyon, France (78) 42 78 50 • Madrid, Spain 675 2162 • Milan, Italy 02-688-8051 • Montreal, Canada (514) 341-5224 • Munich, Germany 089/32.50.11 • Nice, France (93) 20.01.01 • Osaka, Japan 06-304-9300 • Oslo, Norway 02-68.94.85 • Ottawa, Canada (613) 233-1177 • Paris, France (1) 630-2343 • Rome, Italy 839.4792 • Slough, England 0753-33411 • Stockholm, Sweden 08/235480 • Sydney, Australia (03) 887-1122 • Tokyo, Japan (03) 402-6181 • Toronto, Canada (416) 889-7373 • Vancouver, Canada (604) 734-2378.

A Total System

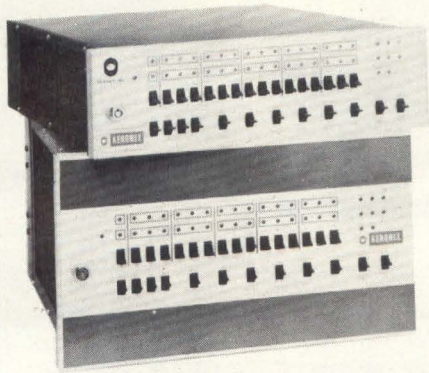

KERONIX IDS - 16 MINICOMPUTERS

A 16-Bit Full Parallel Synchronous, High-Speed
General Purpose, Mini Computer

- INSTRUCTION SET, I/O INTERFACE & MEMORY INTERFACE COMPLETELY COMPATIBLE WITH NOVA™ SERIES OF MINI COMPUTERS
- ADDRESS UP TO 65K (Without the Use of Costly Memory Management)
- HINGED FRONT PANEL WITH FRONT LOADING CIRCUIT BOARDS
- POWER FAIL & RESTART—STANDARD
- FOUR 16 BIT ACCUMULATORS
- 800, 1000, or 1200 NANOSECOND MACHINE CYCLE TIME USING ONE BOARD CPU'S
- 4, 8, 10, 13 OR 17 SLOT CAPACITY
- INTEGRATED MSI & LSI CIRCUITS THROUGHOUT. TRI-STATE ELEMENTS ARE USED FOR ALL I/O & MEMORY LINES
- FORCED-AIR COOLING (UP TO 4 COOLING FANS)
- POWER SUPPLY IS MODULAR FOR EASY SERVICING & PROVIDES UP TO 50% MORE POWER THAN COMPARABLE UNITS
- MANY OPTIONAL FEATURES AVAILABLE
- EXTENSIVE SOFTWARE AVAILABLE
- LOANERS AVAILABLE ON OUR ONE-YEAR WARRANTY

**LOOK FOR OUR COMPLETELY INTELLIGENT
KERONIX MODEL KX-8000, COMING SOON!**

For more extensive information on our IDS-16, please contact us directly.

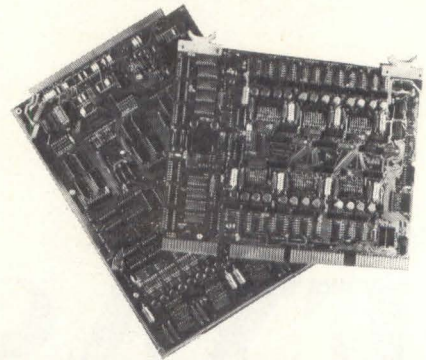

KERONIX ADD-IN MEMORY PRODUCTS

4K, 8K, And 16K Words
PLUG COMPATIBLE CORE MEMORY SYSTEMS

- P-3 SERIES . . . FULLY COMPATIBLE WITH DATA GENERAL NOVA™ 1200 & DCC™-116
- P-4 SERIES . . . FULLY COMPATIBLE WITH DATA GENERAL NOVA™ 800, 820 and 840
- P-5 SERIES . . . FULLY COMPATIBLE WITH DATA GENERAL NOVA™ 2 SYSTEMS
- I SERIES . . . FULLY COMPATIBLE WITH INTERDATA™ 70, 74, 7/16, 7/32 SYSTEMS
- D SERIES . . . FULLY COMPATIBLE WITH PDP-11™_s
- J-1 SERIES . . . FULLY COMPATIBLE WITH MICRODATA™ 800 AND CIP™ 2000
- J-2 SERIES . . . FULLY COMPATIBLE WITH MICRODATA™ 1600
- G SERIES . . . FULLY COMPATIBLE WITH PRIME™ 100, 200, & 300
- E SERIES . . . FULLY COMPATIBLE WITH PDP™ 8E, F, M, AND A

IN ADDITION TO THE ABOVE, KERONIX MANUFACTURES ADD-ON MEMORIES, OEM MEMORIES, AND CUSTOM MEMORIES

**ONE-YEAR WARRANTY
WITH ALL KERONIX MEMORIES**

TM Trademarks registered by Data General Corp., Digital Computer Controls, Inc., Interdata, Digital Equipment Corp., Microdata, Cincinnati Milacron, and Prime. Endorsement of Keronix products not to be implied.

KERONIX

WE HAVE REPRESENTATIVES

George
250 E. Emerson St. • Orange, CA

ms Capability



**VIDEO DISPLAY TERMINAL
KERONIX MODEL K-4000**

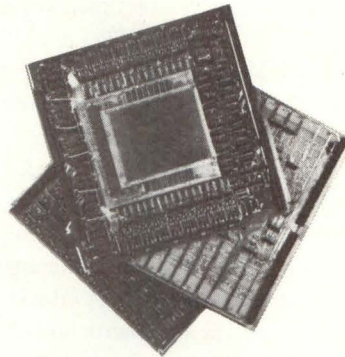

**I/O AND PERIPHERAL CONTROLLERS
FOR KERONIX IDS 16 COMPUTERS
AND NOVA™ SERIES OF COMPUTERS**

- FULL KEYBOARD (Optional 10-Key Pad Available)
- HIGH RESOLUTION, NON-REFLECTING SCREEN; 9" X 7" (12" Diagonal); SWIVEL BASE; EASY VIEWING UP TO 10 FEET; BRIGHTNESS CONTROL; REVERSE VIDEO (Black Characters on White Background, Selectable)
- 80 CHARACTERS PER LINE, 25 LINES, 2000 CHARACTER DISPLAY; STORE UP TO 51 LINES & 4080 CHARACTERS; BLINKING CHARACTERS AT 3Hz RATE
- CURSOR CONTROL (Non-Destructive)
- INTERCHANGEABLE WITH TELETYPE USES STANDARD ASCII CODE
- INTERNAL POWER SUPPLY; RUNS OFF A SINGLE 15" X 15" P.C. BOARD
- VARIABLE BAUD RATE (75 to 9600 Bits Per Second); 10 OR 11 BIT CODE
- ODD OR EVEN OR MARK PARITY
- EITHER EIA OR 20 MA CURRENT LOOP

LOOK FOR OUR COMPLETELY INTELLIGENT

- 1007 I/O BOARDS
- 1008 REAL TIME CLOCK
- 1010 TTY INTERFACE
- 1011 PAPER TAPE READER CONTROL
- 1012 PAPER TAPE PUNCH CONTROL
- 1016 CARD READER CONTROLLER
- 1023 EIA INTERFACE
- 1034 LINE PRINTER CONTROLLER
- 1038 MULTI-PROCESSOR COMMUNICATIONS ADAPTER
- 1046 DISK CONTROLLER
- 1146 FLEXIBLE DISK CONTROLLER
- 1054 EXTENDER BOARDS
- 1060-4 FOUR LINE ASYNCHRONOUS MULTIPLEXER FOR FOUR EIA STANDARD LEVEL LINES (MUX)
- 1060-8 MUX FOR EIGHT EIA STANDARD LEVEL LINES

IN ADDITION TO THE ABOVE, KERONIX MANUFACTURES ADD-ON MEMORIES, OEM MEMORIES, AND CUSTOM MEMORIES

**ONE YEAR WARRANTY ON ALL KERONIX I/O
PERIPHERAL CONTROLLERS**

TM Trademarks registered by Data General Corporation
Endorsement of Keronix products by Data General not to
be implied.

KERONIX INC.

AND DISTRIBUTORS WORLDWIDE

Földvary
California 92662 • (714) 974-0800

502-1244

CIRCLE 57

New Design Innovation

THOMSON

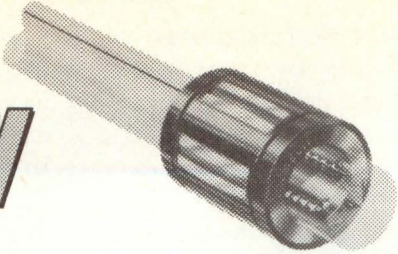

BALL-GROOVE™ SHAFT and 'SUPER' Ball Bushing®

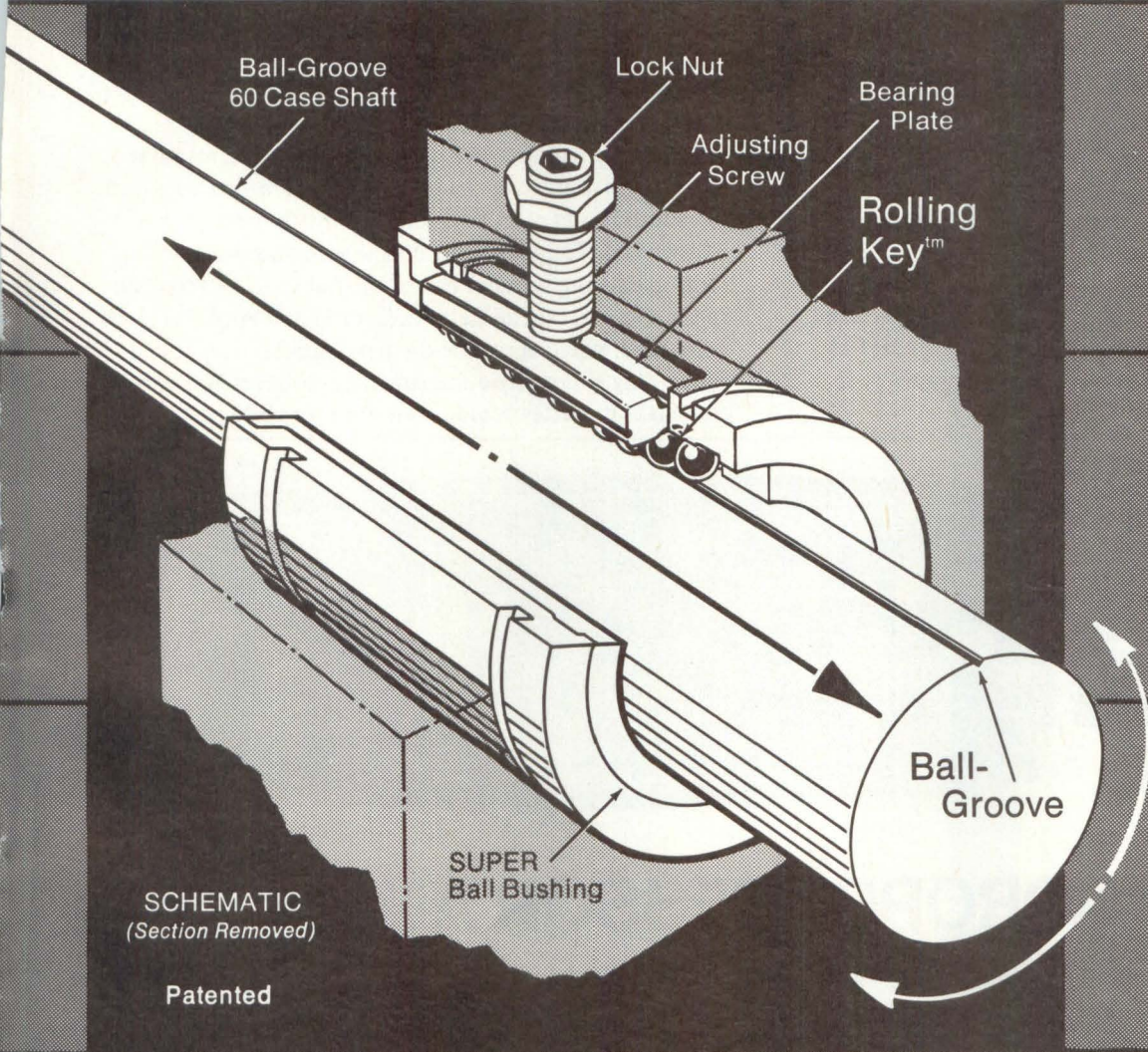

For
TORQUE
Resistance

For
TORQUE
Drive

For
ROTARY
Positioning

Offers New Solutions for Design Engineers
Saves Space – Reduces Cost –
Simplifies Equipment

with
FRICTION-FREE
LINEAR MOTION

For complete technical information write
THOMSON INDUSTRIES, Inc., Dept. BG6, Manhasset, N.Y. 11030

the controller. In the revised system, the computer takes a few microseconds to tell the controller that it's ready to transmit data and then goes on to other processing tasks. The controller executes its program and compresses an entire main memory segment into one disk — and expands the data out back again into memory, when required. This arrangement has just about doubled minicomputer capacity and allows it to handle other tasks. In the second application, a manufacturer who had been using a minicomputer maker's standard I/O interface with a floppy drive installed an intelligent DMA controller and improved total system throughput by a factor of three. Since the price of "intelligence" has dropped so low, "dumb" controllers make less economic sense than they used to, concluded the spokesman.

Since minifloppies transfer data at 1/2 the rate of standard-size floppies, the interface problems are somewhat easier to solve. In many applications, the minifloppy needs no buffer between the CPU and the drive. However, since no formatting standards exist, it's just as complex as for non-standard formatting (double density) for standard floppies according to one maker.

Changing floppy disk technology. Industry spokesmen differ in their beliefs how floppy disk technology will change. Although Bill Miller, Wangco, personally favors grey code recording, he expects MFM encoding to become most widely accepted for single head, one- and two-sided, two head and double-density recording. On the other hand, Jeff Harman, PerSci, claims that customers prefer M²FM encoding, because it provides wider timing margins with higher peak shifts.

In a little more than a year, double-bit density, double-side drives will become standard for standard diskettes and minidiskettes. Doubling the track density suffers from humidity problems due to the hygroscopic nature of the mylar substrate and from thermal expansion problems. Although you can compensate for thermal expansion differences, you can't readily compensate for humidity. Narrower tracks required by higher density diskettes cause more difficult-to-solve problems in standard — rather than in the micro-size disks, because the relative changes between tracks are greater. Existing systems can handle the shorter steps between tracks. Designing the system to expand at the same rate as the diskette would compensate for temperature expansion problems. On the other hand, water absorption from varying humidity levels can cause nonuniform and unpredictable expansion of the diskette substrate. This lack of uniformity can cause errors when the mechanism tries to compensate for a momentary change in track position. Although you could design a servomotor to seek the center of the track, it would be complex and expensive, according to Miller.

In an effort to improve diskette throughput, manufacturers are investigating the possibility of substituting metal foil substrates in place of oriented polyethylene terephthalate (mylar). To provide the compliance necessary to conform to existing types of heads, the foil must be very thin and it could cut the diskette cardboard holder. A flat read/write head would eliminate the need for compliance and allow using a more rigid foil substrate, believes Miller. Non-compliant diskettes could rotate at up to 1800 rpm, reduce

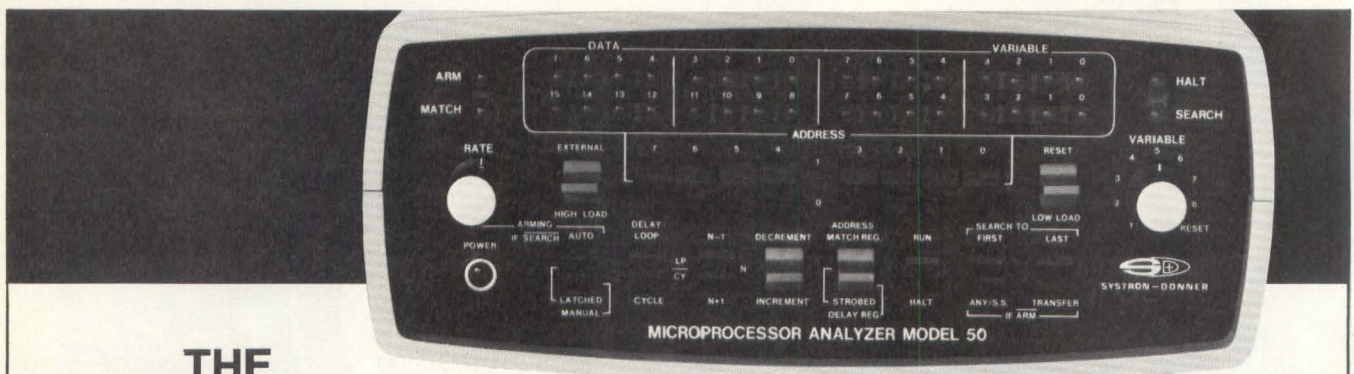

THE HOT NEW S-D MICROPROCESSOR ANALYZER ONLY \$865

but Model 50 does more than a 32-channel logic analyzer costing 3 times as much. **First Universal Analyzer:** Useable with all microprocessor families that have accessible bus structure up to 16 bits data and 16 bits address.

Unique Search Modes: Identify the first and last instruction in a program loop, then step forward or backward through programs.

Passive or Interactive: Use as a passive real time monitor or interactive breakpoint generator.

Find out more about the time-saving (to put it mildly) Model 50 features such as delay by loops or cycles or combinations, single or multiple cycle or loop steps, dual clock, N - 1/N + 1 strobe, multiple unit capability, etc. Contact:

SYSTRON  DONNER

10 Systron Drive • Concord, CA 94518 • Phone (415) 676-5000

CIRCLE 40

AT UNDER \$2000, THE MODEL 40 OEM PRINTER NOT ONLY COSTS LESS TO BUY—IT ALSO COSTS LESS TO OWN.

It costs less to buy because for less than \$2000 you get a 300 lpm printer that's completely operational. All you furnish are 115 VAC and the serial signal source.

Once on-line, our model 40 OEM printer costs less to own. Not only is it highly reliable, it requires little maintenance.

Even when maintenance is needed, the MTTTR averages only ¾ hour, thanks to built-in diagnostics that help pinpoint trouble quickly. And with only seven modular mechanical assemblies and one CMOS logic card, repairs are simple.

This modularity and diagnostic capability also cut the cost of training service personnel.

To reduce your logistics problems and spare parts inventory, there's an 80% parts commonality between all model 40 printers. Plus Teletype offers an exchange repair service that can save you up to 50%.

For more information about our model 40 OEM printers, send in the coupon. Or call 312/982-2000.

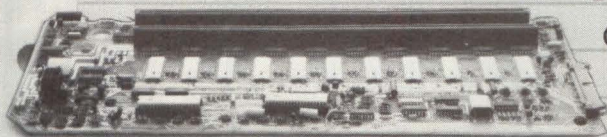
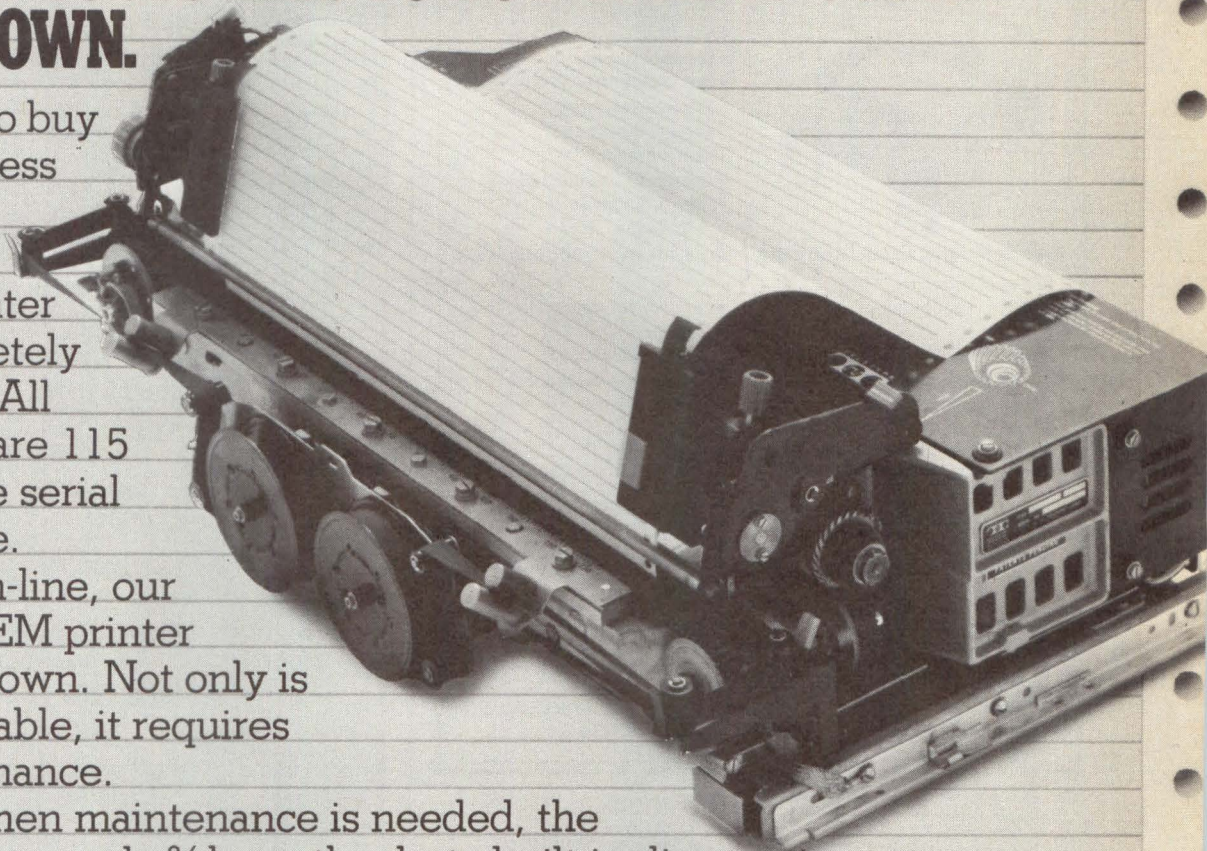

**THE TELETYPE® MODEL 40 OEM PRINTER.
NOTHING EVEN COMES CLOSE.**



Teletype Corporation
Dept. 19-0
5555 Touhy Ave.
Skokie, IL 60076

Please send me additional information about the model 40 OEM printers.

Name _____

Title _____

Company _____

Address _____ Phone _____

City _____ State _____ Zip _____

Teletype is a trademark and service mark registered in the United States Patent and Trademark Office.

The fabulous **Phi-Deck**[®] family of 5 cassette transports under \$100 in quantities of 10

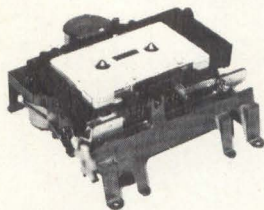

- Featuring:
- Die-cast frames
 - Remote controllable
 - Precise, fast head engage/disengage
 - Quick braking
 - Search FF/rewind 120 ips
 - Speed ranges from .4 to 20 ips

Electronic packages and mag heads for most applications

For application in:

- | | |
|-----------------------------------|---------------------------------------|
| 1. Micro processing | 7. Security/automatic warning systems |
| 2. Data recording/logging/storage | 8. Test applications |
| 3. Programming | 9. Audio visual/education |
| 4. Instrumentation | 10. Telephone interconnect |
| 5. Industrial Control | 11. Hi-Fi |
| 6. RS232 Data storage | 12. Point of sale |



Title I A Division of the Economy Co. dd
 4605 N. Stiles P.O. Box 25308
 Oklahoma City, Oklahoma 73125 (405) 521-9000

- I am interested in application no. _____
 Have Representative call Send application notes

Name _____ Title _____
 Company Name _____
 Address _____
 City _____ State _____ Zip _____
 Phone Number _____

CIRCLE 42

The new, **Accuflo**[®] ink roll is a miser with ink.

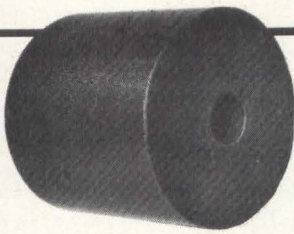

Ink-bearing plastics simplify inking. The plastic ink roll contains its own ink supply. When the ink gives out, you replace the roll. That's when Accuflo plastic pays off. Here's why:

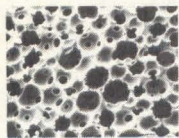

Magnified 60X

Accuflo holds more ink.
 Large pores in Accuflo's interior give it high ink capacity and permit the use of inks with high pigment content.

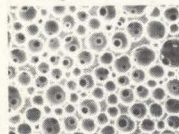

Accuflo gives up its ink slowly.
 Fine pores on the inking surface control ink emission. Large land areas give you even distribution — uniform inking.

A strong, dimensionally stable Accuflo ink roll engineered for your O.E.M. needs can simplify your inking system and give you hundreds of thousands of crisp impressions from a single roll.

Write for a free **Accuflo Design Guide**.

PORELON, INC. A SUBSIDIARY OF JOHNSON DIVERSIFIED, INC.
 Racine, Wisconsin 53403. U.S.A.

CIRCLE 43

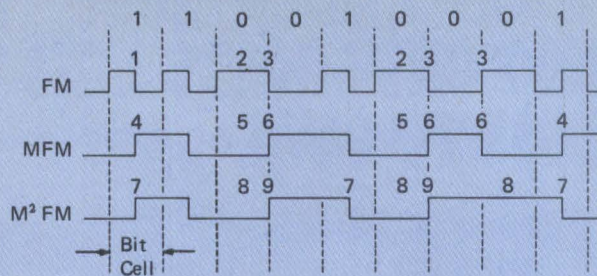

ENCODING MODE RULES

- FM** Each ONE produces a transition at the center of the bit cell time (1); a ZERO preceded by a ONE produces a transition (2); and a ZERO preceded by a ZERO produces a transition at the bit cell time (6).
- MFM** Each ONE produces a transition at the center of the bit cell time (4); a ZERO preceded by a ONE produces no transition (5); and a ZERO preceded by a ZERO produces a transition at the beginning of the bit cell time (6).
- M² FM** Each ONE produces a transition at the center of the bit cell time (7); an odd ZERO produces no transition (8); and an even ZERO produces a transition at beginning of the bit cell time (9).

Note: Circled numbers appear in the nearby timing diagrams to clarify when the transitions produce ZEROs and ONES.

access time and increase throughput substantially.

Although increased diskette speed improves data throughput, the specific application and the host computer determines the required data handling speed. Even though microprocessors usually cannot handle data at a high rate of speed some microprocessor-based computers must be able to store large quantities of data.

choosing the correct drive

The opening statements in this article said that you should choose the drive on the basis differences in stored information integrity and reliability of the transport, storage capacity, speed of operation and cost. First, let's discuss reliability. MTBF (mean time between failures), MTTR (mean time to repair), media life (mean number of head passes/track), design life, data integrity and periodic maintenance requirements are the component parts of drive reliability specifications. The implications and importance of all these specs, except data integrity, are simple to understand and readily available. Data integrity warrants further discussion.

Three types of errors that destroy data integrity are

can't p. 88

MAGNETIC BUBBLE MEMORY TESTING

by T. Ferrio, R. Keenan, R. Naden

Texas Instruments, Inc.

Magnetic bubble devices are made by growing a magnetic garnet film on a nonmagnetic garnet substrate. With no external magnetic field, a maze-like pattern of magnetic domains appears in the film such that the entire sample is magnetically neutral (Fig 1). In the presence of a perpendicular external magnetic field (bias field), the regions of polarity opposite to that of the applied field shrink. A proper bias field, usually created by small permanent magnets which are part of the package, forms small cylindrical regions called bubbles.

The bubbles move in the film under the influence of small magnetic field parallel to the plane of the film. In present devices, a Permalloy pattern deposited on the garnet film controls this movement (bubble propagation). The bubbles move in accord with the changing magnetic poles produced in the Permalloy pattern by a rotating in-plane magnetic field (drive field). Fig 2 shows a common pattern of alternating T's and bars and the corresponding bubble movement as the field rotates. Two orthogonal magnetic coils wound around the device produce the rotating field. The switching of bubbles between alternate propagation paths, the generation of bubbles and the replication of bubbles for a non-destructive read are accomplished by producing localized magnetic fields on the device with current carrying conductor loops. The presence of bubbles is detected by the

magneto-resistive effect of the bubble passing under a conductor carrying a small amount of current. The data in bubble memory devices is represented by the presence or absence of a bubble in each of the propagation positions. The presence of a bubble indicates a binary 1 and the absence of a bubble indicates a binary 0. Access to the device is by a serial data stream.

One common device organization called the major-minor loop device (Fig 3), consists of a "major" propagation loop which provides access to a number of minor loops. The minor loops contain a large number of propagation elements and form actual data storage region of the bubble device. The major loop contains the bubble generation and detection functions. Data is accessed in a block or page which consists of one bit position from each of the minor loops. Various functions are needed to control a bubble device. Transfer gates are used to transfer bubbles between the major and minor loops. The generator creates bubbles to form the data pattern. The replicator element can either make a copy of the bubble for detection purposes or simply transfer the bubble to the detector area to remove it from the device before new data are generated.

Many methods are currently used to package bubble memory devices. To obtain the greatest bit density designers package several bubble devices within one magnet structure. How-

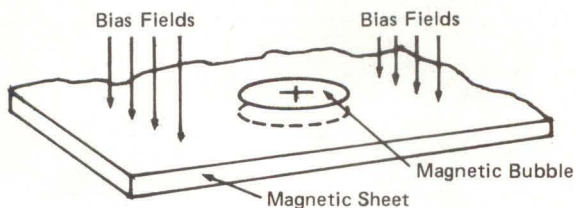
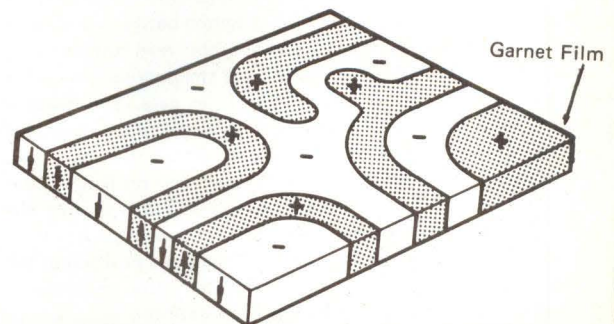

Fig 1 Domains in a garnet epitaxial film are visible when viewed in a polarizing microscope. They appear as alternating dark and light stripes. In the presence of a perpendicular bias field, the regions of magnetic polarity opposite to the field assume a stable cylindrical configuration known as a bubble.



Paper presented at ATE Seminar/Exhibit, March 21-23, 1977, Cambridge, MA. Full Seminar Proceedings available for \$45. Send check to: ATE Proceedings, Benwill Publishing Corp., 167 Corey Road, Brookline, MA 02146.

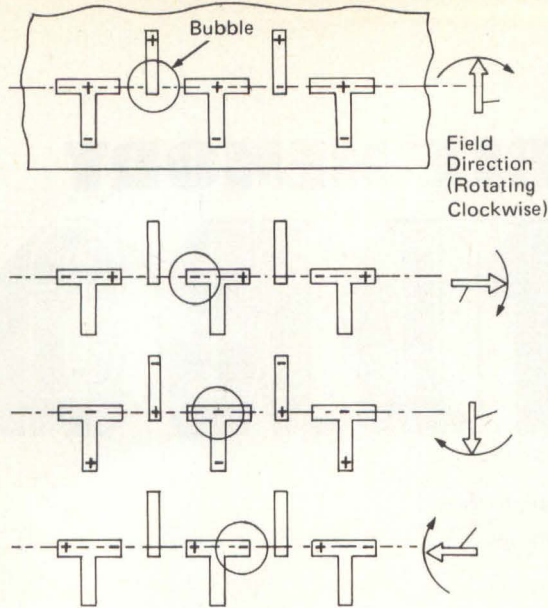

Fig 2 T-Bar Propagation Circuit. The rotating magnetic field in the plane of the garnet film induces magnetic poles in the Permalloy film. The changing magnetic poles cause the bubble to move.

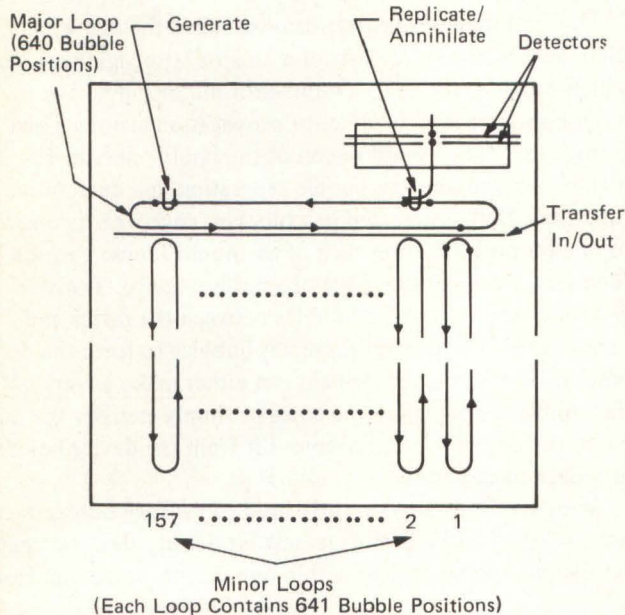

Fig 3 Major loop contains bubble generation and detection functions; Minor loops are the storage area of the device. Transfer gates cause the bubbles to switch between the major and minor loops. Sequencing for a bubble read function is as follows: The drive field is started and the bubbles are moved until the proper block is at the transfer gate. The block is transferred to the major loop and propagated to the replicator where a copy is made of each bubble for detection purposes. The block continues around the major loop until it reaches the transfer gate again where it is transferred back into the minor loops. The number of steps in the major loop is arranged so that the bubbles return to the same position in the minor loops that they came from. The write operation is similar except that the replicator transfers the bubbles out of the major loop and the generator produces a new bubble data pattern.

ever, to minimize cost, a single device can be mounted within a small magnetshield arrangement to form a 14-pin dual in-line package. The characteristics of such a module are given in Table I. For testing purposes the magnetic bias field can be altered by wrapping a small coil around the magnetic shield. Drive field coils are operated with a triangular current waveform. Current in the two coils is 90 degrees out of phase to produce the rotating field (Fig 4). The bubble motion can be started and stopped by controlling the drive field as shown in Fig 4. Bubble memories are non-volatile and data can be stored indefinitely since the module contains protection from stray magnetic fields. Fig 5 summarizes the physical and electrical features of magnetic bubble memory operation.

**Table 1
Module Characteristics**

Useful capacity	92304	Bits
Useful block size	144	Bits
Minor loop size	641	Bits
Percent redundant storage	8.3	%
Drive field frequency	100	KHz
Data rate	50	Kb/s
Average access time (first bit)	4	ms
Size	1.0 x 1.1 x 0.4	"
Pin count	14	Pins
Weight	20	gm
Max. external magnetic field	40	Oe
Operating temperature	0 to 70	°C
Nonvolatile storage temp.	40 to 85	°C

Two factors reflect device performance. The first is the amount of allowable variation in the magnetic bias field. This magnetic bias margin and its size indicates how well the device will work over a range of electrical, mechanical and environmental variations. The second performance criteria is the number of bad minor loops. With current device technology, perfect devices are difficult to produce. To make a cost effective memory system, 13 of the 157 minor loops on a 100 kilobit device are allowed to be inoperative.

the test system hardware and software

TI's computer-based test system consists of a Texas Instruments 990 minicomputer, a microprogrammed bubble memory controller, and various standard computer peripherals (Fig 6). In addition, a programmable bias field power supply and a programmable function amplitude unit are interfaced

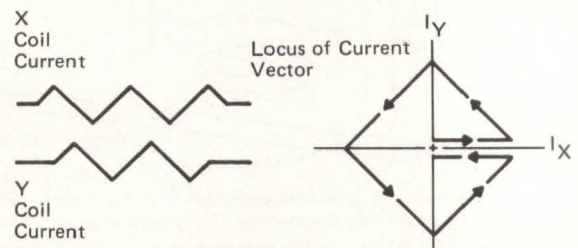

Fig 4 Drive field may be stopped and started as indicated to provide non-volatile storage. The device is mounted at a slight angle within the bias magnet structure to provide a small holding field on the propagation elements.

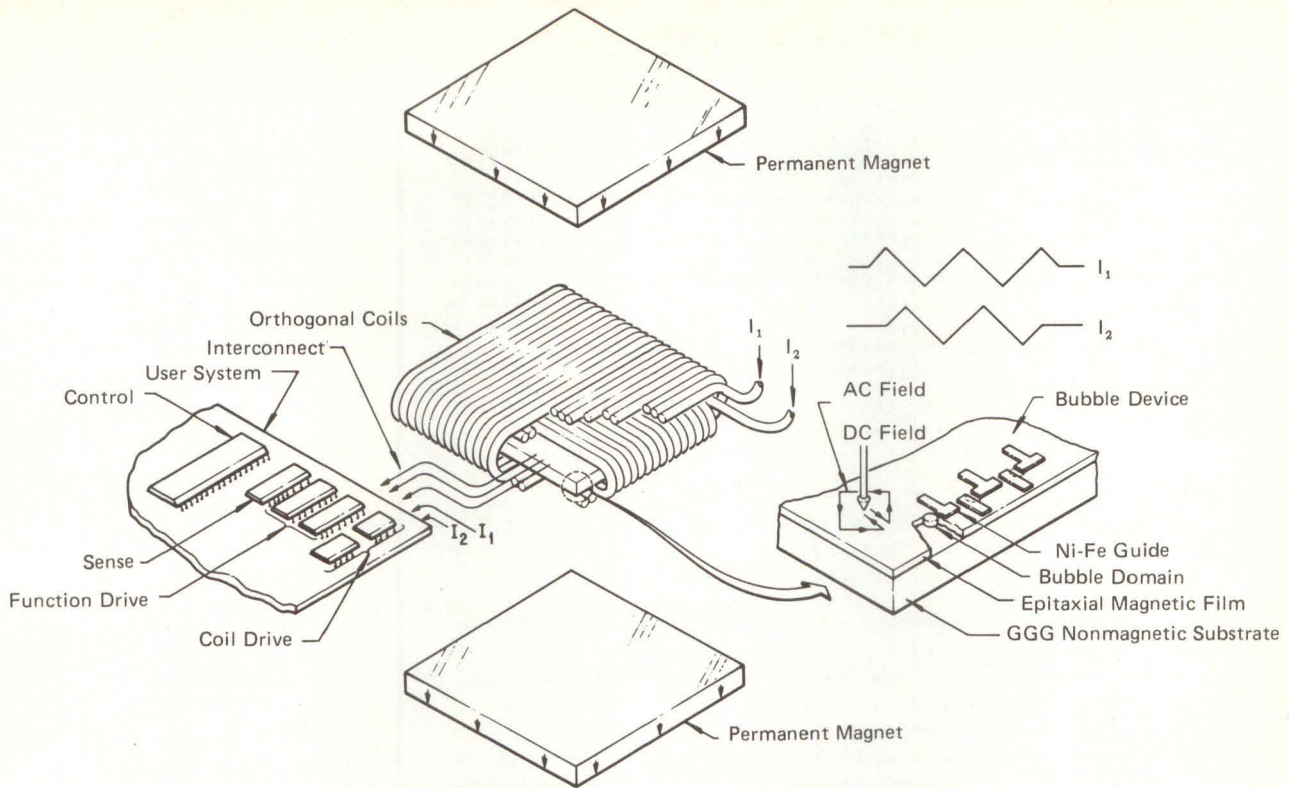

Fig 5 Various components needed for bubble memory operation.

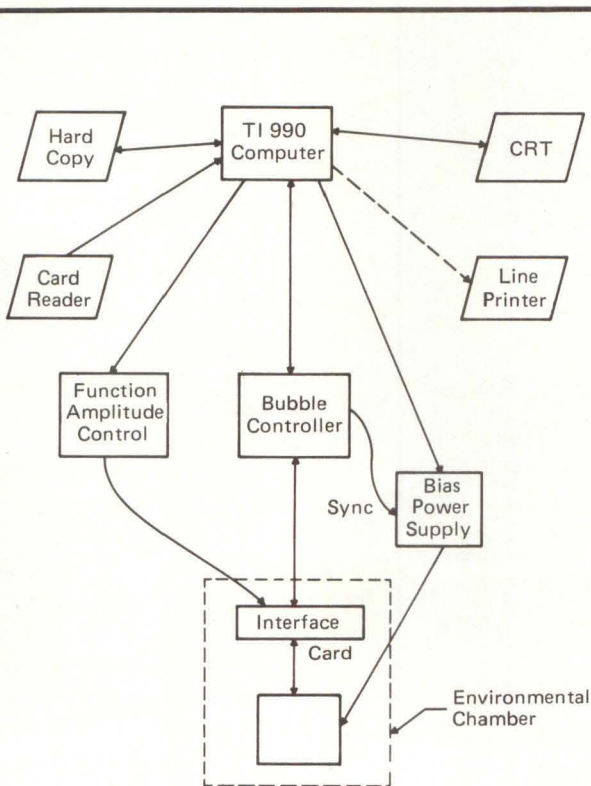

Fig 6 Block diagram of the bubble memory test system

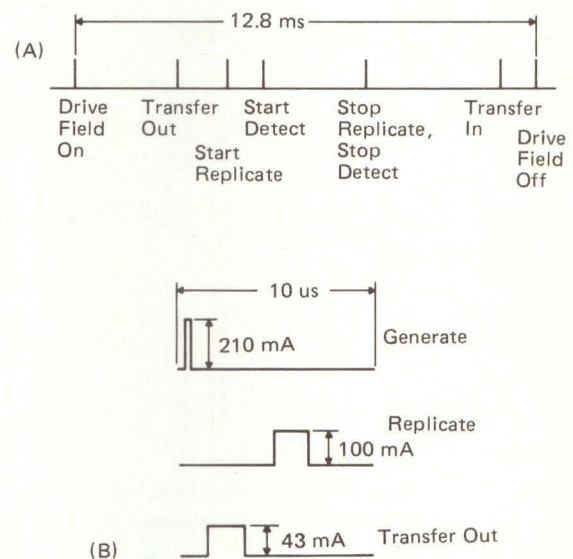

Fig 7 Bubble memory functions must occur during the proper drive cycles (A). The bubble controller contains counters to keep track of which block is at the transfer gate and to count the intervals between functions. During the drive field cycles when a function is enabled, the function current must be precisely controlled (B). This is done digitally in the test system controller. Amplitude, duration and position within the field cycle are all controllable by the test program.

CHARACTERIZATION TEST 10DEC76 10:55:32
 MODULE B6-8-9 TP825 TEMP -42

```

FUNCTION TIMING 10DEC76 10:55:36  MODULE  B6-8-9 TP825  AT  -42 DEG C
      1          2          3          4          5          6
LE DUR FUNC 012345678901234567890123456789012345678901234567890123
32, 18 ADV .....*****.....
48, 18 BDV **.....*****.....
0, 18 CDV .....*****.....
16, 18 DDV .....*****.....
2, 2 GEN **.....*****.....
23, 30 ANH .....*****.....
0, 1 STR *.....*****.....
33, 6 REP .....*****.....
31, 17 XIN .....*****.....
9, 9 CLP .....*****.....
14, 1 STB *.....*****.....
0, 64 DET .....*****.....
8, 11 XOT .....*****.....
42, 5 RWC .....*****.....
FIELD PHASE 0          90          180          270          0
  
```

FUNCTION AMPLITUDES AT TEMP -42
 GEN= 337 ANH= 60 REP= 146 XIN= 30 XOT= 43

Fig 8a Excerpt of output from the characterization test. This printer listing is the actual test result of a 100 Kbit bubble device at -40°C. The test was done with a 200KHz drive field. All bias setting and margins listed are in the units of Oersteds *10 (thus 25 means 2.5 Oersteds). Function position (LE) and duration (DUR) are given in 64ths of the drive field cycle. Bias values represent the deviation from the permanent magnet setting and can be either positive or negative. Function amplitudes are given in miliamperes. Readout gives timings of the functions within the drive field cycle. Asterisks represent the portion of the cycle where the function is on. Function amplitudes, compensated for temperature, are also listed.

MAJOR LOOP ERROR TEST TEMP -42 10DEC76 10:55:43
 NUMBER OF READS = 20

BIAS	MISSING BUBBLES	EXTRA BUBBLES	TOTAL ERRORS
-60	400	0	400
-50	400	0	400
-40	383	1	384
-30	350	0	350
-20	0	0	0
-10	0	0	0
0	0	0	0
10	0	0	0
20	0	0	0
30	0	0	0
40	0	0	0
50	0	0	0
60	0	0	0
70	0	0	0
80	0	0	0
90	0	0	0
100	0	0	0
110	0	0	0
120	0	0	0
130	177	0	177
140	400	0	400

Fig 8b Bias margin test of the major loop. In this test the bubbles are kept in the major loop to eliminate transfer and minor loop errors from the test. The margin can be seen to be 16 Oersteds.

MASK BIAS LOW -28 HIGH 110 MARGIN 138
 SELF GENERATION TEST TEMP -44 10DEC76 10:56:17BIAS= 40
 MASK 0000 0000 0800 0000 0000 0000 0000 0004 0000 0007 NBIT 2

Fig 8c The minor loop mask is determined. This device has 2 bad minor loops over a 13.8 Oersted bias range. The bits in the last word of the mask are not from the device since a block contains 157 bits.

to the test system. The bubble memory controller performs all of the bubble memory timing operations. Test programs, written in a high-level test language, usually include some degree of data reduction and often include procedures to produce graphical output on the hard-copy terminal or line printer. The CRT terminal is used for high speed data display and operator control. A card reader is used for the system load and the input of test programs.

The operation of bubble memories can be broken into two levels of control. To sequence the bubbles properly, the control functions must be enabled during prescribed cycles of the rotating drive field. One level of control counts cycles of the rotating field to access the required page of data correctly (Fig 7a). The bubble memory controller contains a programmable sequencer which performs this operation. The program can accept commands from the host computer, start the drive field, count the required intervals for the device architecture and the required page and stop the drive field when the bubbles have returned to the minor loops. This program can be loaded or modified by the host computer so that different bubble device architectures may be tested. An assembler for the controller was implemented by using the macro capabilities of the IBM 370 assembler to define the various controller instructions. An output formatter was written to make the resultant listing and load deck easier to use. The microcode for a typical device architecture consists of about 125 instructions. Ease of programmability using an assembly language has simplified the system changes required to test new device architectures.

Each of the function currents must be accurately timed within the drive field cycle (Fig 7b). A function timing RAM divides the drive field cycle into 64 discrete intervals. The function RAM operates as a recycling shift register with one track or channel for each of the bubble functions. Each of the channels contains a set of logical ones in that period of the bubble cycle where the function is to be turned on. The programmable portion of the controller enables the output of the appropriate channel during the proper field cycle. The contents of the function timing RAM may be changed by the test program so that timing tolerances may be

GEN	NOMINAL	LE 2	DUR 2	AMP 337
LE	LOW	HIGH	MARGIN	
0	-52	179	231	
1	-51	181	232	
2	-53	183	236	
3	-49	179	228	
4	-43	180	223	
5	-48	181	229	
6	-44	179	223	
7	-41	182	223	
8	-38	182	220	
9	-31	181	212	
10	-32	179	211	

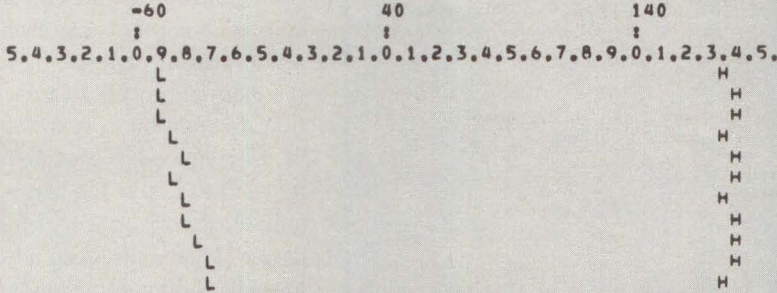

MODULE B6-8-9 TPB25 TEMP -43 10DEC76 10:56:44

GEN	NOMINAL	LE 2	DUR 2	AMP 337
DUR	LOW	HIGH	MARGIN	
1	-50	180	230	
2	-47	180	227	
3	-39	180	219	
4	-34	180	214	
5	-15	180	195	

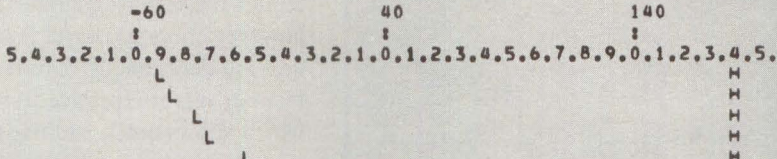

MODULE B6-8-9 TPB25 TEMP -43 10DEC76 10:56:42

GEN	NOMINAL	LE 2	DUR 2	AMP 337
AMP	LOW	HIGH	MARGIN	
277	-50	82	132	
287	-48	181	229	
297	-47	180	227	
307	-52	181	233	
317	-52	181	233	
327	-51	181	232	
337	-46	181	227	
347	-39	177	216	
357	-47	179	226	
367	-45	179	224	
377	-45	181	226	

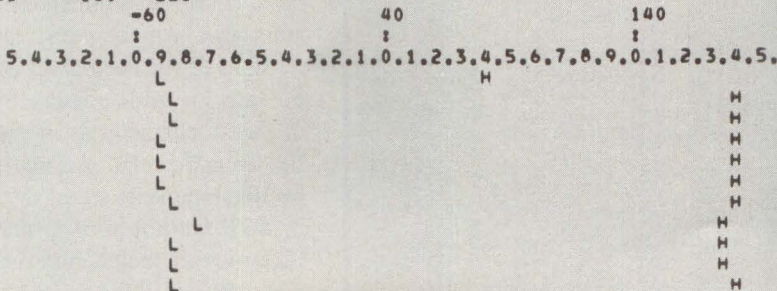

MODULE B6-8-9 TPB25 TEMP -42 10DEC76 10:56:57

Fig 8d The bias margin of the generate function is shown as the position, duration and amplitude change. Results are listed in both tabular and graphical form.

DOUBLE DENSITY FLOPPY OS for HP2IMX, RTE-II

... also OS/8, RT-11, RDOS, DOS, OS 16MT2, CP/M, RSX 11M, IRIS and many more. AED's new 6200 Series double-density diskette systems allow random access storage at a fraction of the cost of big disks. And in addition to DEC, DG and Interdata operating systems, the AED 6200 now operates as LU#2 or LU#3 under HP RTE-II, with a driver from AED that will run all RTE-II functions. This versatile MFM subsystem maintains the RTE-II on a single drive, allowing the other drives to be used for auxiliary storage or peripheral disks. AED's 3100 Series subsystems with IBM-compatible media are also available for use with RTE-II. All systems can be provided with choice of standard or low-profile cabinets. See below for our low prices.

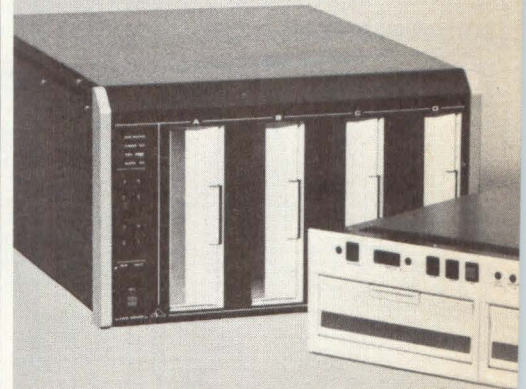

Compare these features

	Double Density AED 6200	IBM Compatible AED 3100
Number of Tracks	77	77
Transfer Rate	500K bps	250K bps
Storage on Both Sides	yes	yes
Programmable Formatter	yes	yes
Typical Record Sizes per side		
• 128 bytes/sector	542,080 bytes	256,256 bytes
• 256 bytes/sector	670,208 bytes	315,392 bytes
• 512 bytes/sector	670,208 bytes	315,392 bytes
IPL, Drive Select, Write Protect	yes	yes
LED Status & Error Indication	yes	yes
Vertical Rack Space		
• 2 drives	5.25"	5.25"
• 4 drives	10.5"	10.5"
Price: Quantity 25 (DMA I/F)	\$2,060 ea.	\$1,930 ea.

Most interfaces available

AED offers the widest selection of interfaces in the entire industry. Call today for up-to-date list.

Advanced Electronics Design
 P.O. Box 61779, Sunnyvale, California 94088
 Telex: 357498 Cable: Disksystem

call
Disk City
 PHONE 408-733-3555

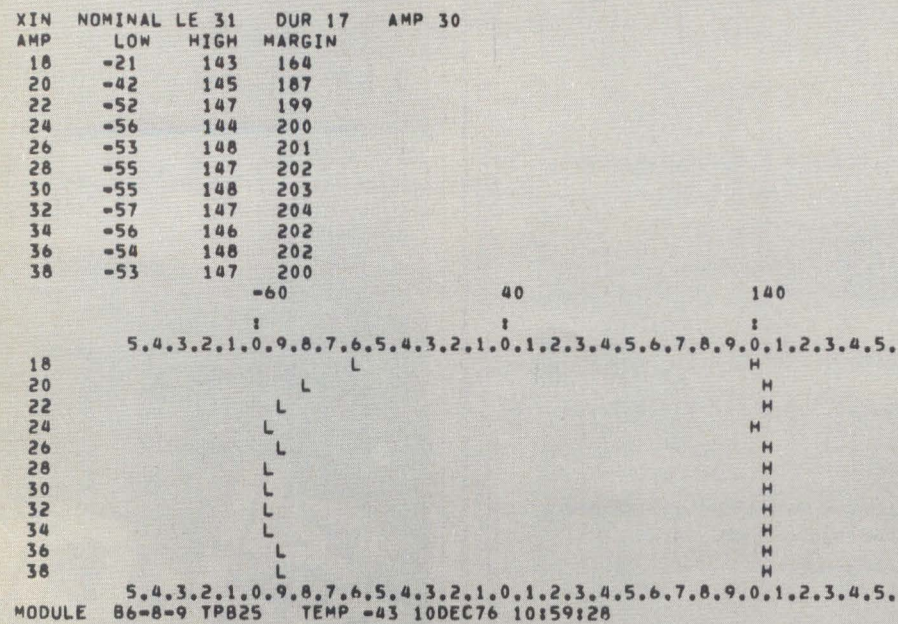
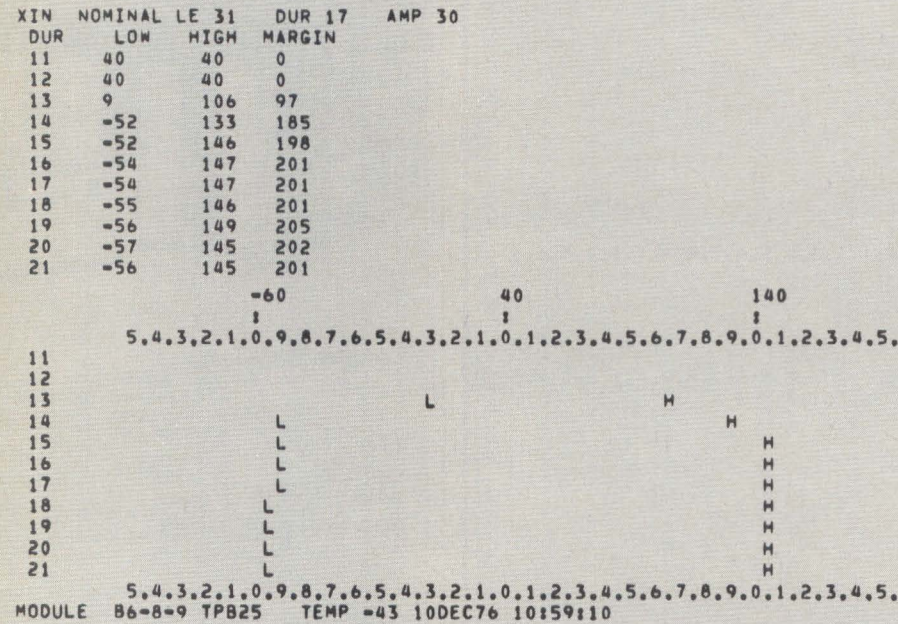
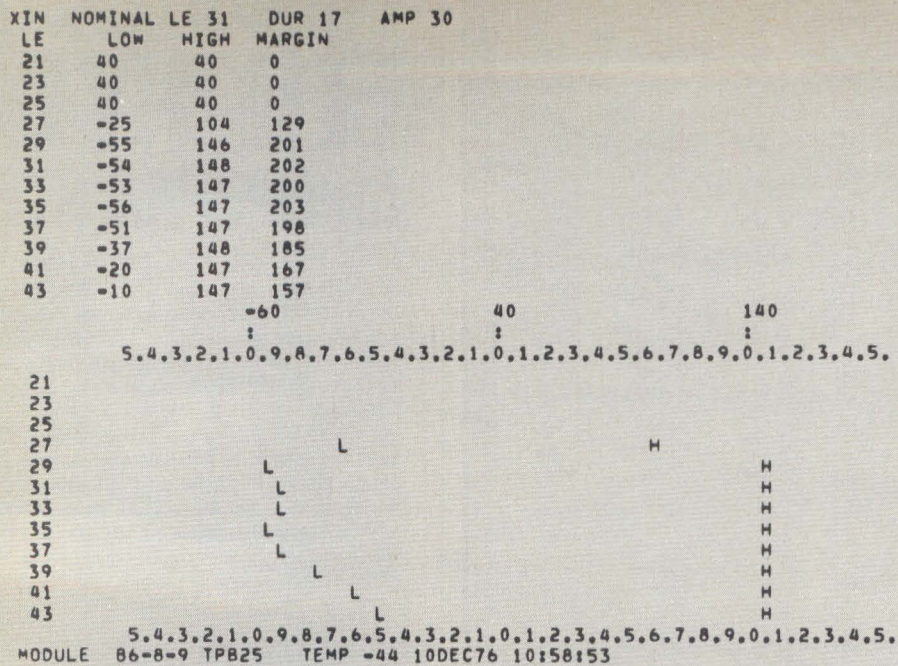

studied. Bubble memory function current amplitudes can be controlled by the 990 minicomputer with a one millampere resolution, allowing the design of test programs which can easily determine the sensitivity of bubble operation to current amplitude changes.

As mentioned earlier, small coils are wound around the magnetic shield so that the bias field may be changed for testing purposes. These coils are attached to a computer-controlled power supply to provide high-speed control of the bias field to a 0.1 Oersted resolution. In addition, this power supply can be programmed to provide narrow current pulses to test the bias sensitivity of individual propagation elements on the device. These pulses can have a duration as small as 20 microseconds which corresponds to two drive field cycles at 100 KHz drive frequency.

The bubble test language (BTL) was designed to be similar to BASIC, providing a language simple to use but comprehensive enough to support changing test methods. Simplicity is needed to reduce the test programming effort; however, more powerful language features are occasionally required. BTL is a table driven interpretive test language which allows quick additions to the set of valid statements as well as fast changes to any existing statement type. BTL has proven capable of the adaptation needed as our test techniques have improved.

Each BTL statement consists of a verb and a number of parameters. The language contains no keywords outside of the verb field. There is no limit to the number of characters in a variable name, allowing the use of meaningful names. Alphanumeric labels are used rather than line numbers so that programs can be made more readable. Extensions to the normal set of arithmetic operators is made possible by the use of the '#' character as an operator prefix. Thus the relational operators used in 'IF' statements are of the form #EQ or #GT. Output print formatting specifications are included in the list of variables to be printed and default specifications allow the formatting to be optional.

For instance the statement: PRINT A will print the variable A in a decimal

◀ Fig 8e Similar to (8d) for the transfer in function.

MAJOR LOOP PROPAGATION

DELAY	LOW	HIGH	MARGIN
100	-54	171	225
100	-54	173	227
100	-55	170	225
100	-56	170	226
100	-55	169	224

MINOR LOOP PROPAGATION - MASK BITS = 2

DELAY	LOW	HIGH	MARGIN
100	-59	141	200
100	-60	139	199
100	-61	139	200
100	-62	138	200
100	-61	137	198

COMPOSITE MAJOR LOOP

LOW	HIGH	MARGIN
-50	115	165
-58	115	173
-57	116	173
-55	115	170
-56	115	171

COMPOSITE MINOR LOOP - MASK BITS = 2

LOW	HIGH	MARGIN
-61	117	178
-55	116	171
-61	117	178
-57	111	168
-58	114	172

Fig 8f Propagation and composite margins. Each test is repeated 5 times. Minor loop composite includes propagation and all device functions.

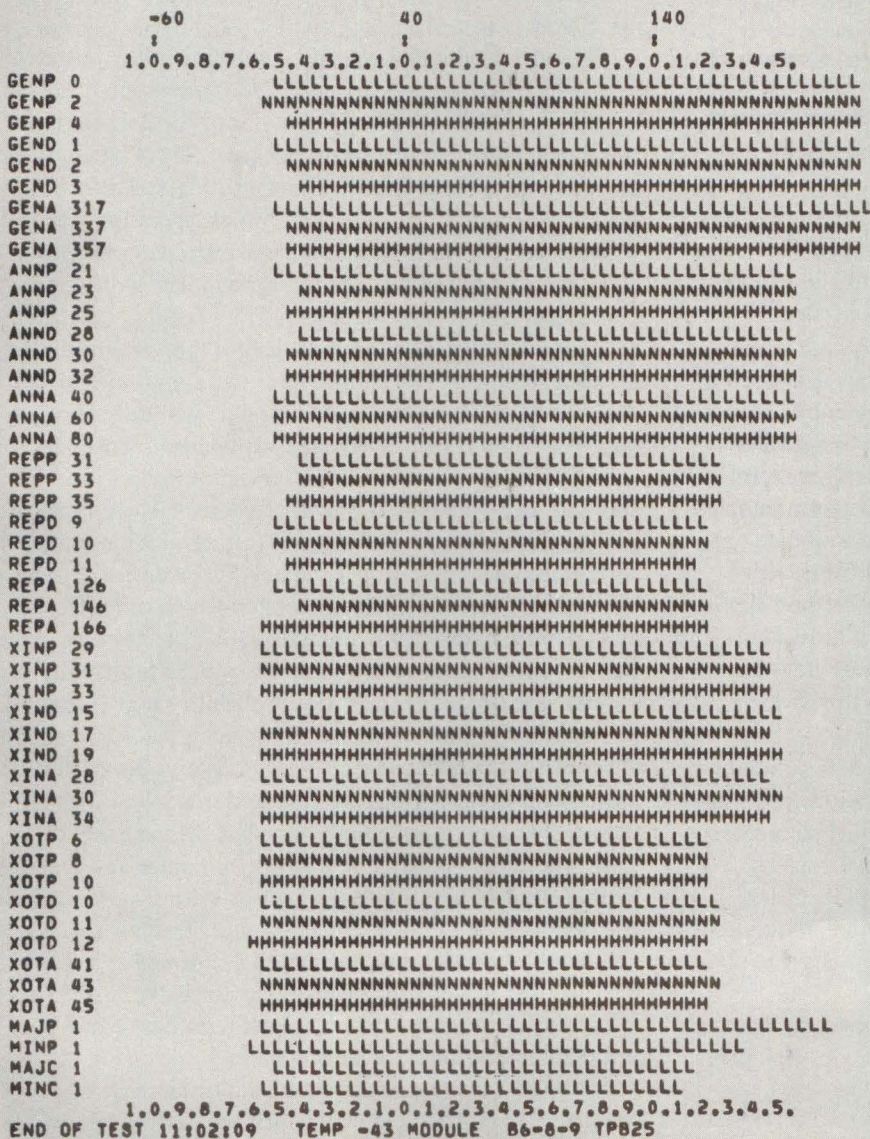

Fig 8g A summary of the test results giving margin bar graphs for 3 values of each variable parameter.

from ovenaire



Crystal Controlled DIP Oscillators designed especially for digital clock applications

Low-cost Models DT1-121 & DT1-221 feature...

Frequency Range: 20KHz to 25 MHz
 Overall Stability: ±0.010%—Model DT1-121
 ±0.005%—Model DT1-221
 Temperature Range: 0°C to +70°C
 Output Waveform: Squarewave 50/50 ±20% to drive 10TTL loads. 0.4V max. "0" and 2.4V min. "1" level.

Input Power: Voltage +5V±5%. Current 30 to 120mA depending on frequency.

Package: 14 pin DIP, glass-filled nylon. Fits into standard 14 pin socket.

Size: (WxLxH) Approx. 0.50"×0.80"×0.37"

Other Ovenaire Highlights...

State of the Art High Stability Crystal Oscillators
 Ovenized Crystal Oscillators • TCXO • VCXO
 Crystal and Component Ovens • Thick Film Hybrid
 Circuit Custom Services

for additional information contact...

ovenaire

Division of Walter Kidde & Company, Inc.
 706 Forrest St.—P.O. Box 1528, Charlottesville,
 Virginia 22902 • 804-977-8050—TWX 510-587-5461

CIRCLE 45

Watch for the July and August Issues

Patent activity data — who is patenting what and with what intensity — provides you with an important vector that helps you determine directions of technological developments. In May, we reported the patent status of magnetic bubble memories; in July, we will report on the patent status of floppy disks; and in August, we'll have a patent report on 14 types of memory systems other than magnetic bubble.

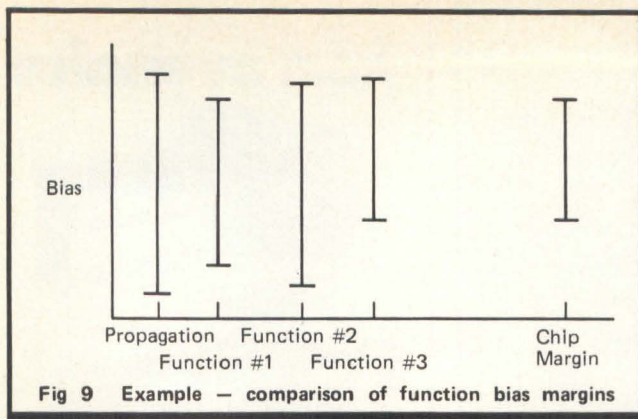

Fig 9 Example — comparison of function bias margins

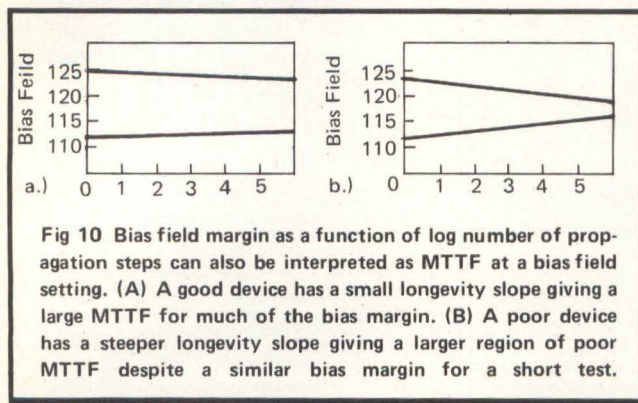

Fig 10 Bias field margin as a function of log number of propagation steps can also be interpreted as MTTF at a bias field setting. (A) A good device has a small longevity slope giving a large MTTF for much of the bias margin. (B) A poor device has a steeper longevity slope giving a larger region of poor MTTF despite a similar bias margin for a short test.

format. If a hexadecimal format is desired, the operator #HEX may be used; PRINT #HEX,A.

If a data pattern needs to be printed from an array, the number of elements will follow the operator; PRINT #HEX 5, B. The language was thus designed to allow more complicated statements when added power is needed.

A 'DEVICE' statement in the language allows the program to acquire the device architecture specifications at execution time so that programs can be written independent of a particular device design. This allows us to test various developmental devices without a full-time test programming effort. The language contains special statements to perform bubble I/O. To test the sensitivity of the device to various data patterns, the language contains pattern I/O statements with automatic data comparison during reading. A method is provided to test an individual device in a memory subsystem where the data from many devices is multiplexed together.

Test language programs have been written to provide a variety of tests; 5 typical programs are;

- **Diddle Program** is used for module set-up and semi-module or system checkout. Data is written to and read from the device and displayed on the CRT screen. Many test parameters may be controlled to get a 'feel' for device performance.
- **Characterization Test** produces "Schmoo" plots of bias margin as a function of the amplitude, position and duration of each device function. Overall device and propagation margins are also tested (Fig 9).
- **Long Term Error Test** determines a device mask by doing a large number of reads of a once-written device. A mask may be entered and the accuracy of the mask may be checked over long periods of time.
- **General Longevity** performs 8 different functional sequences, each of which can be repeated 10^N times for N between 1 and 8. The maximum bias margin for data storage

without error is a function of N for any of the test sequences.

- **Radar Longevity** determines the bias margin of small sections of the propagation path for 10^M steps where M is between 1 and 4. The bias field pulse width is 80 microseconds. The major loop, minor loop or detect path may be tested.

bubble device testing

Because of its importance, much of the current testing procedure inspects the change in bias margin as some other testing variable changes. If the magnetic bias field is too large, bubbles will tend to collapse and disappear. If the field is too small, the bubbles will become too large for one storage location and will 'strip out' during propagation. For current devices with a nominal bias field of about 120 Oersteds, the margin may vary from 8 to 20 Oersteds. To ensure the most reliable operation of the device, this margin should be as large as possible. In general, each Permalloy element and each bubble function has its own operating margin. These margins do not fully overlap (Fig 9). The overall operating margin is the intersection of the margins of all of the functions. Advanced testing techniques such as the Radar Longevity Program allow us to test the operating margin of each device element. Thus we can correct the device design and detect mask defects as well as identify individual device defects.

The final production test of a bubble memory must determine which minor loops are defective. The system using the bubble device will not place bubbles into these minor loops and data read from the loops is not used. These bad loops comprise the bubble device redundancy mask. The bubble system processes all data through a mask operation when either writing or reading. It is important to determine an accurate mask so that no additional bad loops will appear during use. Most of the bad minor loops are easy to detect by simply writing data into every minor loop and reading it back. These types of failures have two symptoms: either data will disappear when written or data will be read when none is written. Errors associated with pattern sensitivity and the leaking of bubbles from one minor loop to another are types of errors that are harder to detect. These types of problems increase the difficulty of testing and, more importantly, the time required to accurately test a device.

Another factor in bubble operation which can affect the mask determination is the longevity effect. It has been shown that during propagation a bubble has a finite probability of self-collapse (disappearing). This probability is near zero at the midpoint of the bias range and increases as the upper or lower bias limits are reached (Fig 10). Due to device defects, this error probability may be increased in a minor loop although that loop is not found to be bad during a short test. Two actions may need to be taken to minimize any problems by this effect: First, the operating bias setting must be chosen at a point which promises the best longevity results, and second, a longevity test may have to be performed as a part of the final test to find loops with a bad longevity curve. The effects of the longevity curve on long term device operation and the impact to testing are still being studied (Fig 11).

Although bubble device bias margin is the range of perpendicular magnetic field over which the device will operate, a statement of bias margin must also include data on the length and nature of the test. A less demanding test will discover that a device has a wider margin than a longer, more

WE REPAIR DATA GENERAL™ AND DEC™ AND DCC™ EQUIPMENT

Consider These Advantages:

- FAST TURNAROUND
- RELIABILITY
- LOW COST (repairs quoted before work begun)
- LOANERS AVAILABLE FOR MOST BOARDS*
- 30 DAY WARRANTY ON REPAIRS

MAINTENANCE CONTRACTS AVAILABLE

* Loaner Boards Subject to Availability

Trademarks registered by Data General Corp. and Digital Computer Controls, Inc. Endorsement of Keronix by either Data General or Digital Computer Controls not to be implied



KERONIX INC.

For Further Information, Contact:

George Földvary

Keronix, Inc.

250 E. Emerson St.

Orange, California 92665

(714) 974-0800 TWX 910-593-1344

WE HAVE REPRESENTATIVES AND DISTRIBUTORS WORLDWIDE

CIRCLE 64

complicated test because of a combination of factors including longevity effects and bubble-bubble interaction.

Our first testing showed that each minor loop appeared to have its own bias margin. Most of the loops on the device will appear quite similar but occasionally some are encountered with very narrow margins. Thus one problem in assigning a redundancy mask is the interaction of device margin and the number of loops masked. As we improved processing and reduced device and mask defects, we were able to identify several of the bubble functions as being limiting factors the bias margin. Since the functions use peculiar propagation elements and entail the alignment of a conductor mask to carry the function current, this came as little surprise. A concentrated effort was begun to characterize the bubble functions (references 5,7). We found that device design changes and process improvements could increase the function bias margin and increase the timing and amplitude tolerances. We also found that several functions would need amplitude compensation to operate reliably over a 0 – 70°C temperature range.

Bias margin and mask are affected by the data pattern used in testing. This pattern sensitivity or loading factor is due to bubble-bubble interaction. In general, about 3 Oerstedes must be subtracted from a "simply determined" margin to account for loading effects.

Due to the changes in magnetic properties of the garnet film the optimal bias field value will change with temperature (Fig 12), introducing the concept of magnet tracking. To achieve device operation or even simple data retention over a range of temperatures, the temperature characteristics

of the bias magnet must match that of the film. For some garnet material compositions a matching magnet material is difficult to find. Device/magnet tracking mismatch also adds to the mask determination problem and places more emphasis on maximizing the device bias margin.

The test system approach that we have developed has proven comprehensive enough for our current laboratory and production efforts. The information learned from our characterization effort is being applied to device improvements and refinement of production test techniques. Our current results show that the time required for production testing needs to be reduced.

References

1. A.H. Bobeck, H.E.D. Scovil, "Magnetic Bubbles," *Scientific American*, June 1971.
2. A.H. Bobeck, P.I. Bonyhard, and J.E. Geusic, "Magnetic Bubbles – An Emerging New Memory Technology," *Proceedings of the IEEE*, August 1975.
3. D.M. Lee, "Bubble Memory for Microprocessor Mass Storage," *Digest of papers from the 14th Computer Society Conference*, Spring 1977.
4. R.A. Naden, "Longevity and Error Rate Measurements of 92Kbit Bubble Devices," to be presented at International Magnetics Conference, June 1977.
5. R.A. Naden, W.R. Keenan, and D.M. Lee, "Electrical Characterization of a Packaged 100Kbit Major/Minor Loop Bubble Device," *IEEE Trans. on Magnetics*, MAG-12, 685-687, Nov 1976.
6. P.W. Shumate, P.C. Michaelis, and R.J. Peirce, "Long Term Propagation Studies in Magnetic-Bubble Devices," *Proceedings of the AIP 19th Annual Conference on Magnetism and Magnetic Materials*, 1973.
7. S.K. Singh, et al., "Functional Characterization of 92Kbit Capacity Dual Inline Bubble Memory Packages," to be presented at the International Magnetics Conference, June 1977.

IN WIRE-WRAPPING  HAS THE LINE.....



WIRE DISPENSER

- 50 FT. ROLL OF 30 AWG. KYNAR® WIRE-WRAPPING WIRE
- CUTS THE WIRE TO LENGTH
- STRIPS 1 INCH OF INSULATION

AVAILABLE IN FOUR COLORS

WD-30-B BLUE WIRE
WD-30-Y YELLOW WIRE
WD-30-W WHITE WIRE
WD-30-R RED WIRE

\$345
EACH

MINIMUM BILLING \$25.00
ADD SHIPPING CHARGE \$1.00
NEW YORK STATE RESIDENTS
ADD APPLICABLE TAX

®KYNAR PENNWALT

OK MACHINE & TOOL CORPORATION

3455 Conner St., Bronx, N.Y. 10475 (212) 994-6600 / Telex 125091

CIRCLE 48

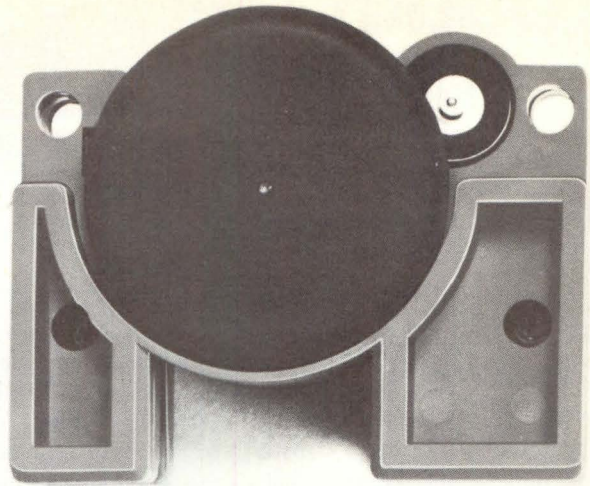

Now here's magtape storage that a competitively priced OEM manufacturer can afford!

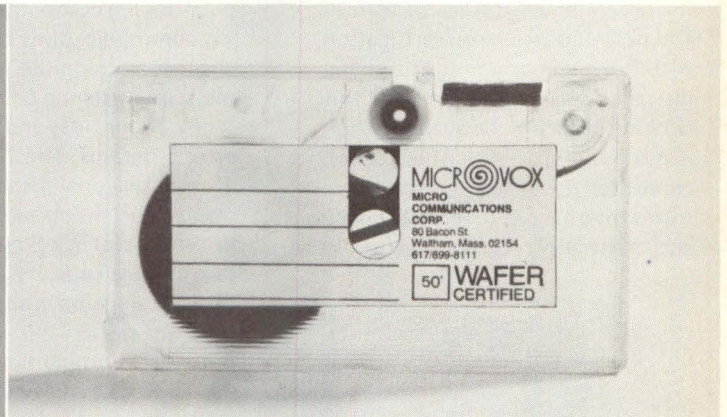

Bet you think you can't afford to offer your customers magtape storage. Even at the 5000-piece price, the cheapest, least reliable cassette transport goes for \$75 or more, and certified cassettes are \$7 and up. Well, think again.

The 5000-piece price for MicroVox certified magtape Wafers is \$1.80 to \$2.20, depending upon tape length. And simple, reliable, single-point-drive MicroVox transports go for as little as \$36 in that kind of quantity. Matter of fact, we'll let you in on a secret: If you're willing to forego a few frills, you can buy MicroVox transports for under \$22.

How come? It's simple. A Wafer is a continuous-loop cartridge and, in a continuous-loop cartridge, the tape automatically winds around the outside of the reel when it's pulled from the center. That's why a precision-injection-molded plastic MicroVox transport can drive tape at a single point without any of the differential speed problems that make cassette transports so expensive and unreliable.

What's the catch? There's only one. Wafers are very small – so small you can mail two of them in an ordinary envelope for 13¢, without protective packaging. Consequently, you can't store more than half a megabit in a single Wafer. Still with us? Great. Call or write us for information about OEM magtape storage that won't price your product out of the market. We'll send you a free Wafer along with our literature.



**MICRO
COMMUNICATIONS
CORP.**

80 BACON STREET
WALTHAM, MASS. 02154
617/899-8111

A BUCKEYE INTERNATIONAL COMPANY

SPECIALIZED COMMUNICATIONS TERMINAL

MEGADATA System 700/CT terminal for banks (monetary transfer), airlines and national/international message switching systems combines the programmed storage of forms and data entry control/verification with full data communications for message switching system. For the banking industry the system automates the preparation of letters of credit, for the airline industry it performs internal carrier communications and message preparation/transmission,



for general-purpose message switching it provides automated forms control for bills of lading, specialized messages, weather data and a whole host of similar applications.

System 700/CT is a family of communications terminals designed to meet and anticipate the needs of large communications network users through the next decade. The equipment provides direct cost savings because of improved data-handling capabilities, greater speed and ease of operation and text editing, and greater data reliability. The 700/CT has advantages for users of communications networks who wish to upgrade the quality and cost effectiveness of their network. The terminals are programmed to be plug-to-plug compatible with all networks and require no changes to existing message switching computers, communications lines and software programs. For example, when programmed for low-speed

networks, the equipment represents a direct upgrade replacement for the Model 28ASR, KSR and RO five-level Baudot (Teletype TM) devices that are at present used in many communications networks.

Since the 700/CT terminals are plug-to-plug compatible with existing communications networks, no changes are required in the user's message switching computers, communications lines and existing software programs. The 700/CT has a 15-inch diagonal display screen, a display format up to 80 x 24 and a dot matrix of 7 x 8 or 7 x 9. Message storage capacity is nominally 5K, transmission storage 3K and program storage 2K. Megadata Computer and Communications Corp., 136 Orville Dr., Bohemia, NY 11716.

Circle 130

HIGH PERFORMANCE MONITOR

A series of 7 x 9 dot matrix monitors, designed specifically for use in OEM data terminals, has an added capability for electronic horizontal video centering within the raster and electronic vertical linearity control. Field technicians will now be able to make finer video adjustments

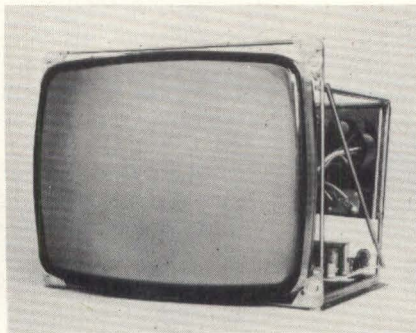

in less time without disturbing factory-aligned deflection components. The original simple subassembly interconnection idea has been expanded so that a modular sync stripper board for EIA composite inputs can

be added as required, greatly reducing the need to order and inventory several chassis types. Extended performance options include high line rates, dynamic focus and skip-scan features. The new series is compatible with earlier TTL-12/15 models and drop in units for competitive makes are also available. Where size is a special problem, a new extra-compact 12" chassis can be ordered. For complete information contact George Wagner, Ball Brothers Research Corp., Electronic Display Div., P.O. Box 3376, St. Paul, MN 55165. (612) 786-8900. Circle 145

ALL ABOUT TEXT EDITING TERMINALS

The VT71/t microcomputer-controlled text editing terminal offers advanced editing functions and capabilities such as smooth scrolling, restoration of deleted paragraphs and up to 32 user-definable functions. The VT71/t contains an integral LSI-11 programmable microcomputer, easy-to-read characters and can store up to 31,000 characters internally. Bulletin available from Communications Services, Digital Equipment Corp., 444 Whitney St., Northboro, MA 01532. (603) 883-3232. Circle 135

LOW-COST ON-LINE PLOTTER CONTROLLER

Operating functionally as an intelligent interface, CalComp OPC permits specified CalComp plotters to be driven locally or remotely by a range of computers and calculators. To enable the broadest possible interfacing capabilities, the OPC was designed to convert computer output in standard RS-232-C serial format and standard IEEE 488 parallel format into plotter commands. An undedicated parallel input port is available for specialized inputs. Re-

mote operation, via a customer-supplied asynchronous modem, is possible through an RS-232 interface.

The OPC offers integral firmware to generate plotter commands for lines and characters. Up to 96 characters, which can be scaled and rotated, are stored in its read only memory. It is priced at \$3500 with first deliveries scheduled for July 1977. California Computer Products, Inc., 2411 W. LaPalma Ave., Anaheim, CA 92801. (714) 821-2541.

Circle 131

POLLING/ADDRESSING TERMINAL

EECO D400, a smart, stand alone, polling terminal that is Burroughs, Lear Siegler and TEC compatible, includes absolute cursor addressing, field protect format, full text handling edit package, audible alarm, roll/page mode and blink character.



Reduced-operator-fatigue features include a non-glare screen, upper & lower case 5 x 9 characters with true descenders and brightness/contrast adjustable control. There is provision for up to eight screen edge mode indicators, two of which can be defined by the user. The detachable key board generates a full 128 ASCII characters and has a standard alpha numeric typewriter layout with 16 special function keys (32 with shift), 15 key numeric cluster and a 15 key text handling pad. All functions can be CPU or keyboard controlled. The terminal is 19" wide, 13.25" high and 16.5" deep with keyboard attached. Unit price is approximately \$2000; \$1500 in OEM quantities. EECO, 141 E. Chestnut, Santa Ana, CA 92701. For fastest response, phone (714) 835-6000 and ask for Jerry Pisano or "Computer Terminals".

Circle 146

Victor's high-speed matrix printer can fit into your systems design.



129

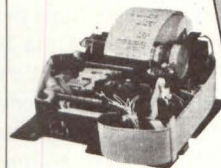

130

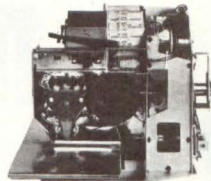

150

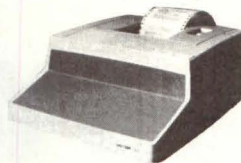

5000

If you're starting from scratch in designing your own print mechanism, the Victor Model 129 matrix print head will optimize your price-performance ratio.

You can enjoy this popular and reliable device already built into the Victor Matrix Printing Mechanism 130 (which can be integrated readily into all types of data generating devices).

It's also available in the Multi-Position Printing Mechanism 150 that can print three documents simultaneously.

You'll find Victor terminals meet your needs, too.

The 5000 series allows interfacing with RS232C, 8-bit parallel or TTY current loop. Options include sprocket feed and 230 volt operation.

The 5005 terminal comes complete with a matrix printing mechanism, integrated power supply, and driver circuitry.

So, to see how Victor components can fit into your program, just send the coupon.

 VICTOR

Ted Singer
Victor Comptometer Corporation
3900 N. Rockwell Street
Chicago, Illinois 60618
312-539-8200

Send Technical Literature

Sprocket Feed Printers

All Victor's Print Mechanisms

Name _____

Company _____

Street _____

City/State _____

Zip _____ Phone _____

product news

1K x 4 STATIC RAM REPLACES INTEL PART

This 1K x 4 static RAM, the SY2114, is a plug-in replacement for the Intel device with the same number. For use in high-performance, low-cost memory systems, it is TTL compatible and operates from one 5V supply. The unit is totally static and requires no chip enable pulsing, clocks or refresh circuitry. Price: \$20 in 100s. Synertek, 3050 Coronado Dr., Santa Clara, CA 95051. (408) 984-8900 **Circle 237**

LINE PRINTER CONTROLLERS SERVE H-P 2100 COMPUTERS

For use with Hewlett-Packard 2100 computers, these line printer controllers operate most printer models from Centronics, Dataproducts, Data 100 and Data Printer, as well as the DEC LA180. Line printers from Printronix, Tally and Diablo, which emulate the Centronics or Dataproducts printers, are also compatible with the controller. Transparent to the host computer, the unit is compatible with diagnostics, drivers and

operating systems and comes on one printed circuit board requiring one slot in the H-P chassis. A 15-ft cable is supplied. Prices: \$850 to \$1250, depending on line printer model selected. MDB Systems, Inc., 1995 N. Batavia St., Orange, CA 92665. (714) 998-6900 **Circle 234**

32K-BIT STATIC ROM SERVES HIGH-DENSITY APPLICATIONS

Designated the TMS 4732, this 32K-bit static NMOS ROM is organized in 4K 8-bit words and serves high-density, fixed-memory applications such as logic function generators and microprogramming. Maximum access time equals 450 ns, minimum cycle time measures 450 ns and typical power dissipation equals 450 mW. The ROM is fully TTL compatible; all inputs can be driven directly by series 74 TTL circuits without the use of external pull-up resistors, and each output can drive two series 74 TTL circuits without the use of external resistors. All data outputs are three-state for OR-tying multiple devices to a common bus. Two programmable chip select controls provide data readout and system decode. The TMS 4732 comes in a 24-pin plastic DIP with pin rows on 600-mil centers. Price: \$20 in 1000s. Texas Instruments, Inquiry Answering Service, P.O. Box 5012, M/S 308 (Attn: TMS 4732), Dallas, TX 75222. (713) 494-5115 x2781 **Circle 232**

Keep Your Memory Up when the power's down

Carefree...the perfect way to back-up your computer's back-up, emergency power system. Install a Carefree battery, and forget it. It'll take care of itself and you when an emergency strikes. It's maintenance free... spill-proof...it's built with a dual cover...and it's completely rechargeable. You can count on it keeping your memory up when the rest of the power is down. Carefree batteries. That's what they're called. That's what they are.



in 30 rechargeable sizes

EAGLE P ICHER
SINCE 1843

EAGLE-PICHER INDUSTRIES, INC. Commercial Products Dept. D
P.O. Box 130, Seneca, Mo. 64865 Telephone (417) 776-2258

CIRCLE 51

9-TRACK TAPE TRANSPORT USES TELEPHONE-SYSTEM POWER

For operation from 48 Vdc telephone-system power sources, this tape transport serves message accounting, traffic recording and other communications applications. The Mod 10/48 system, which mounts in a 19" rack, includes a tape transport, read/write head, read/write electronics, control electronics and 48 Vdc power supply, a dc-dc conversion system. A line filter protects the power bus from tape-unit-generated noise. Power usage requirements include 1.0 A standby, 2.0 A in fwd., rev. and rwd., and 4.0 A program. The drive unit has a 9-track read-after-write head and records 800 cpi NRZ and PE (IBM-ANSI compatible) at 12.5 or 25 ips. Price: \$3200 in OEM quantity. Wangco, 5404 Jandy Pl., Los Angeles, CA 90066. (213) 390-8081

Circle 236

COMMUNICATIONS CONCENTRATOR SERVICES 32 PHONE LINES

The MC-1 communications concentrator is a micro-processor-based peripheral system that provides multi-line Touch Tone input handling capabilities for most computers. The system can service up to 32 telephone lines and supports such communications data sets as the Bell 407A and 407B, several commercially available 403-type units, and the Bell Transaction* telephone, automatic call distributor and call director.

All transactions between the MC-1 system controller and the host computer occur through standard data formats without the need for elaborate support software or special interfacing hardware. Vocal Interface Div., Federal Screw Works, 500 Stephenson Highway, Troy, MI 48084. (313) 588-2050

Circle 239

\$995 CRT TERMINAL SPORTS OPTIONAL 11-KEY PAD

For use in small business systems, computer timesharing, with mini- and microcomputers and in other OEM/end-user computer applications, the VC303A data terminal provides serial asynchronous RS232C interface, 1920-character display (24 lines x 80 characters), eight switch selectable data rates from 110 to 9600 baud, 12" non-glare CRT, composite video output for slave monitors and direct X-Y cursor addressing by computer or operator. Its 64 ASCII character keyboard has a cursor control key cluster, tactile feedback and auto repeat, and detached 11-key numeric pad is optional. Other available options include upper/lower case keyboard and display, switched serial interface with lighted "Print" key switch for printer, cassette or floppy disk, parallel input and output interfaces, and custom keyboard-character fonts. Price: \$1595 in singles, \$995 OEM. Volker-Craig, Ltd., 266 Marsland Dr., Waterloo, Ont., Canada N2J 3Z1. (519) 884-9300

Circle 240

IRIS

The foremost business operating system for NOVA* type minicomputers

NOW WITH PARTITIONING



Educational Data Systems

1682 Langley Ave. • Irvine, California 92714 • (714) 556-4242

CIRCLE 52

product news

IRONLESS ROTOR MOTOR: IMPROVED PERFORMANCE AT LOWER COST

An ironless rotor 26mm motor which offers a high-temperature winding and a 3mm shaft as standard features at no additional cost uses precious

metals for the commutator and the brushes for high reliability and maintenance-free operation. Designated Copal's LS Series, the motor is designed for cassettes and capstans, metering pumps, X-Y recorders, medical instrumentation, high speed printers and other applications demanding rapid response time, low inertia and minimal RFI for efficient operation. According to EME, the encapsulation of the windings provides a physically stronger armature, allowing the motor to withstand

temperatures in excess of 120°C without deformation. The result is high torque output and longer life. In general, the construction of skew wound ironless motors provides low rotor inertia, very fast response time, high efficiency, high starting torque and low starting voltage. The Copal LS Series motor measures 26mm in diameter and 41mm in length; shaft diameter is 3mm. Electric Motor Engineering, Inc., 6331 Hollywood Blvd., Los Angeles, CA 90018. (213) 469-7393. **Circle 142**

Reach the #1 market in New England for personal computing and small business systems

BOSTON'S FIRST Personal Computing Fair at Boston University August 4, 5, and 6

The Boston area teems with hobbyists; professionals, engineers, academics, designers, and business men and women who are anxious for a hands-on look at your new equipment. This show will be open to all. Registration fees are \$5.00 for the general public and \$3.00 for students from all Universities.

Booths are available at Boston University's large modern George Sherman Union. Each booth is 8' X 10'. Price for the three day Personal Computing Fair is only \$200.

We've also scheduled 18 seminars, from free lectures to beginners to 3-hour technical, state-of-the-art seminars led by professionals. These seminars will attract a wide range of individuals interested in all aspects of personal computing. The Sherman Union has conference rooms in which you can schedule group demonstrations of your equipment for up to 60 visitors at a time — at no extra charge.

Reserve your booth today. For fast action, CALL (617) 731-2326.

Send to: Boston University Personal Computing Fair
Boston University Summer Term
725 Commonwealth Avenue
Boston, MA 02215

- Please reserve a booth for my display
- Please send me more information

Name _____
Title _____
Company _____ Tel. _____
Address _____
City _____ State _____ Zip _____

UNIVERSAL PRODUCT BAR CODE READER

A bar code reader designed for scanning UPC (Universal Product Code) symbols reads UPC version A and E and EAN 13/EAN 8 symbols. All source printed colors that meet UPC symbol specifications can be read. The UPC reader includes the Intermec 1230 RUBY WAND®, a visible (red) light pen, for hand scanning. For remote terminal and data communications applications, Model 9211 is plug compatible with most



CRTs and asynchronous communications terminals. The unit has dual connectors to allow tandem operation with any on-line RS-232C equipped terminal. External switches select baud rate, parity and half or full duplex operation. The reader offers bit serial rates from 110 through 9600 baud. An audio signal confirms a correct read. Single quantity price is \$1074; OEM quantity discounts are available. Interface Mechanisms, Inc., 5503-232nd St., S.W., Mountlake Terrace, WA. (206) 774-3511. **Circle 140**

CARD-MOUNTED SUPPLIES

Card-mounted power supplies designed to fit within computer terminals and microprocessor-driven systems are mounted on a 4½" square printed-circuit board and provides outputs ranging from 5V @ 1.5A to 30V @ 0.42A. To meet a wide variety of applications requirements, eleven single-output and two dual-output models are available. Dual outputs are ± 12V and ± 15V @ 0.42 and 0.37A respectively. All outputs are voltage-fixed and factory-adjusted to within ± 1%. An optional, accessible voltage control permits a 5% adjustment on models providing 20V or lower outputs, or an adjustment of 1V on models that provide more than 20V. On dual-output CD devices, the optional adjustment controls both voltages which in turn are a fixed to within 1% of each other. Current ratings on all models are 0 to full load; regulation is 0.1% +5mV NL-FL, ± 0.1% ± 5mV for a 10% input change. To facilitate incorporation of these supplies within operating hardware, the CD series are designed to mate

with standard P-C card edge connectors. Barrier strip terminals are available on all CD models as an option. All models are inherently protected against short circuit by a fold-back characteristic; any model can be furnished with optional overvoltage protection which crowbars the outputs in the event of a voltage rise between 1 and 2V or 10-20% (whichever is greater) above maximum output voltage. The addition of overvoltage protection does not alter the outline dimensions of the supply. Prices for the CD series start as low as \$29 ea/99 for single output units, \$41 ea/99 for dual-output versions. ACDC Electronics, 401 Jones Rd., Oceanside, CA 92054. (714) 757-1880. **Circle 132**

PAPER TAPE FOR ANY 300 BAUD TERMINAL

DSI's whisper quiet (58 dB) paper tape reader/punch combo will attach to any terminal thru an RS-232 or current loop connector. Full/half duplex, line/local, search/edit control, back space, tape feed and

selectable baud rates are all standard features. The SRP-300 may be

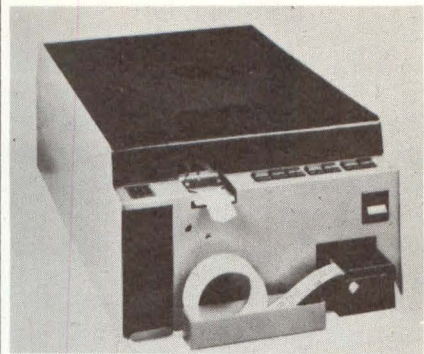

remotely controlled from the line or terminal thru the standard DC1-DC4 codes. The \$2095 unit features the MODUPERF tape punch mechanism which cuts all paper, rolled and folded tapes without readjustment or modification. DATA SPECIALTIES, INC., 3455 Commercial, Northbrook, IL 60062. (312) 564-1800. **Circle 147**

ALL ABOUT SEALED SOLID STATE KEYBOARDS

A 12-page review of sealed solid state keyboards for applications in

MDB SYSTEMS presents...The DEC PDP-11* Connection

GP Logic Modules · Peripheral Controllers · Communications Interfaces · Special Purpose Modules

New: MDB DR11C General Purpose Interface and MDL-11 Asynchronous Serial Line Adapter

MDB Systems products always equal and usually exceed the host manufacturer's specifications and performance for a similar interface. MDB interfaces are software and diagnostic transparent to the host computer. MDB products are competitively priced; delivery is usually within 14 days ARO or sooner.

Here are some MDB Systems connections to DEC PDP-11 computers:

- General Purpose Interfaces
11C Module with 16 bit input and 16 bit output registers; 20 user wire wrap positions.

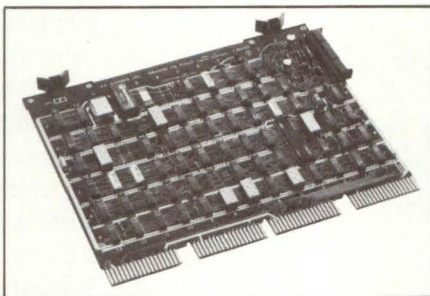

Pins and sockets optional.
1710 Module with 40 IC positions for user logic; sockets optional.

11B Direct Memory Access Module with 12 IC positions for user logic.

DR11C, a direct DEC equivalent. Digital I/O Module.

Wire Wrappable Module with 70 IC positions, sockets optional.

Unibus Terminator.

- Communications Modules
MDL-11 Asynchronous Line Adapter.

MDL-11W Asynchronous Line

CIRCLE 60 FOR PDP-11; 61 FOR NOVA; 62 FOR INTERDATA; 63 FOR LSI-11.

Adapter with line frequency clock.

MDU-11 Synchronous Serial Line Adapter.

- Device controllers for most major manufacturer's
Printers
Card equipment
Paper tape equipment

All controllers are software transparent and use PDP-11 diagnostics.

Check first with MDB Systems for your PDP-11 computer interface requirements.

MDB also supplies interface modules for Data General NOVA* and Interdata computers and for DEC's LSI-11 microprocessor.

MDB

MDB SYSTEMS, INC.

1995 N. Batavia St., Orange, California 92665
714/998-6900 TWX: 910-593-1339

*TMs Digital Equipment Corp. & Data General Corp.

product news

severe environments explains how the keyboards are built to provide protection against leakage between the keyboard and panel, through the keyboard and around each key plunger. The Hall-effect keyboards, offered in 16, 26, 63 and 75-key alphanumeric configurations, are designed to operate at temperatures from -40 degrees to +75 degrees C (-40 degrees to +167 degrees F). All keyboards in the SW-S line meet the requirements of NEMA 2, 3, 3R, 12 and 13 as well as MIL-STD-202 for sealing, vibration and shock, MICRO SWITCH said. The brochure also describes individual sealed key plungers for those who might wish to make their own keyboards. It includes mounting dimensions, product photographs and electrical data. Write MICRO SWITCH, a division of Honeywell, 11 West Spring St., Freeport, IL 61032.

Circle 141

HIGH SPEED, LOW COST OEM LINE PRINTER

A line printer priced to compete with dot-matrix and other serial printers employs a belt-impact printing mechanism developed by EPSON. This mechanism enables the unit to printout high quality,

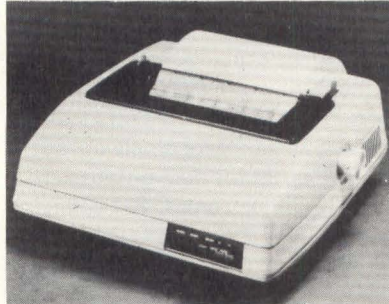

fully-formed characters at a minimum print rate of 150 lines per minute with a full 64 ASCII character set in 80 column format using only 150 watts maximum. Designed to meet OEM requirements, Model 10 is available in friction feed and pin feed versions. The friction feed version is single-unit priced at

\$1,800 FOB Torrance, CA; U.S. deliveries are scheduled to begin in September. EPSON AMERICA, INC., 23844 Hawthorne Blvd., Torrance, CA 90505. (213) 378-2220.

Circle 138

MAG TAPE DRIVES

Two new members of the Series X Magnetic Tape Drives, Model 70X and 80X, handle 7" and 8½" reel sizes, respectively. In addition to

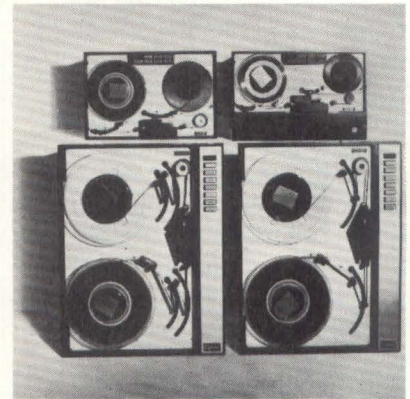

spares commonality of the head, tape guiding hardware, EOT/BOT,

Midcon /77

High Technology, OEM Electronics Exhibition now in Chicagoland — the most diversified electronics market in the U.S.

November 8, 9, 10
At O'Hare
Exposition Center
In Chicago

For three days this November, the representatives of all facets of the electronics industry will meet in Chicago, at Midcon the first broad-based, high technology, OEM electronics exposition to serve the rich and highly diversified Midwestern marketplace. The show is produced in the same efficient system as Wescon and Electro with the same intensive attendance generating campaign and the same sponsors, IEEE and ERA. The exhibition is presented by category — Components and Microelectronics, Instrumentation and Control Systems, Production and Packaging, Mini and Micro Computers and Peripherals.

For Exhibit Information

(Attach your Business Card here)

Send to



999 No. Sepulveda Blvd., El Segundo, CA 90245

File Protect, control switches and electronics, the full line shares a common Universal Dual Density Read/Write Board which features NRZI, PE or both, and is pluggable for any speed for 12½ ips to 75 ips, unique to Cipher products.

Since the cost of sparing new peripherals is a significant expenditure for an OEM, the commonality of spares among the Series X family permits economical flexibility in matching tape capacity to user requirements. In effect, if an OEM is spared for any member of the Series X family, he is spared for all of them. All members of the Series X magnetic tape drive family feature direct drive motors and dual formatting. In addition, the 70X features speeds from 12½ ips to 37½ ips. Available from stock, the units are priced from \$1600 in large volume OEM quantities. Cipher Data Products, Inc., 5630 Kearny Mesa Rd., San Diego, CA 92111. (714) 279-6550. **Circle 136**

PRINT HEAD DESIGN INCREASES THROUGHPUT

Claiming another breakthrough in print head design, Victor Comptometer's 129-112 print head has a 20 percent improvement in duty cycle over the standard model permitting continuous operation for greater periods of time. Designed for applications such as wide carriage, ticket,

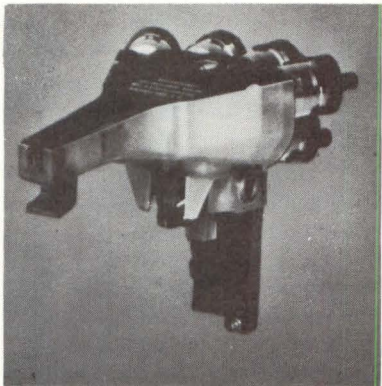

label and receipt printers, calculators, intelligent terminals and cash registers, the 7-wire dot matrix print head produces any character, even graphics. Print speed: 110 characters per second; weight: nine ounces; 1,000 unit price: \$59.50. Victor Comptometer Corp., 3900 N. Rockwell St., Chicago, IL 60618. (312) 539-8200. **Circle 143**

high speed program loader for **LSI-11**[®] diagnostic tool data logging numerical control



23 lb Portable Unit
RETMA Rack Mounting
Available

- 100% DECtape[®] Compatible
- Supports RT-11 as System Device or as Peripheral under RT-11 System
- Loads 800 x faster than paper tape
- Trouble-free in severe environmental conditions
- Outstanding Price/Performance Value



Computer Operations, Inc.

9700-B PALMER HWY. • LANHAM, MARYLAND 20801 USA
(301) 459-2100 • TELEX 89-8327

CIRCLE 55

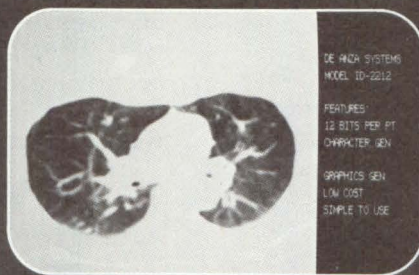

MEDICAL IMAGES



REMOTE SENSING

De Anza Systems New ID 2000 Series

**Provides you with a low cost solution
to your Image Enhancement and Processing Needs.**

Take your choice... We have Systems with 256, 1024, or 4096 levels of intensity, in color or grey scale, with or without Intensity Transform Tables. Options provide interactive cursors and cursor controls, overlays and interfaces to most minis.

We have a lot more to say to the world of Image Processing... and it's all worthwhile.

De Anza Systems Incorporated

3444 De La Cruz Blvd.
Santa Clara, CA 95050 (408)988-2656

CIRCLE 56

called soft, hard and seek. Hard errors are due to magnetic media defects that cause an improper signal. These errors are usually not possible to correct. Soft errors are usually caused by contaminants (airborne or due to wear particles) that pass between the head and the magnetic medium. The wiping action of the head or a self-cleaning wiper generally removes most of these contaminants. Random electrical noise of a few μ s duration and small defects in the written data or track not detected during the write operation may also generate soft errors. Seek errors occur when the head reads data in nonexistent or improper locations.

To describe errors and how they occur let's look at a typical diskette drive, many of which indicate errors segregated into these four categories: data, parity, seek and controller.

- Data errors originate when disk data is absent or unrecognizable, when the read data contains an erroneous CRC code or when no index hole is found on the diskette during the formatting operation. The most common source of data errors is the absence of a diskette during operation. The controller looks for data and when it finds none, it executes an error return. The next most important error source is dirty, worn or miswritten diskettes. Magnetic dirt can drop bits or inject extraneous bits into the data stream.

Controller CRC logic detects these types of errors. Third in importance, head alignment, if skewed or not aligned in the center of the track, affects signal strength or creates media interchangeability problems. Fourth in importance, the lack of index marks during formatting and writing an entire track of data generates a data error.

- Parity errors are indicated when the controller checks the parity on each command that it receives and verifies that it contains an error. Detecting an error aborts the command.
- Seek errors arise when the system selects a nonexistent track or logical unit, when it improperly "homes" (track 00) during an initialization and when the track byte of the header read does not match the expected value. Improperly set unit select mapping jumpers cause most of this type of error. For example, setting the unit select switch so that no logical drive 0 exists or so that logical drive 0 maps to a nonexistent physical drive results in an error. A misaligned head can also cause seek errors.
- Controller errors indicate faults in controller operation or switch violations. Every time the controller is initialized, it executes extensive self-testing microcode for a fixed time interval. If the controller detects a malfunction, it responds by lighting the controller error indicator, sets the done and error flags to the CPU interface and refuses to accept new commands.

FLEXIBLE DISK DRIVE RECORDING MODES

Designers who attach a flexible (floppy) disk drive to a computer make many decisions that directly affect system cost/performance ratios. One of the first and perhaps most significant decisions they must make involves selecting a recording mode.

IBM compatibility

In systems that require IBM-compatibility the designer must select single-density recording, since IBM data entry equipment, generally considered as the standard for data interchange between various equipment incorporating floppy disks, uses this format and double frequency, or FM, code. With a constant frequency signal and fixed speed disk rotation recording, density varies from 1836 data bits-per-inch (722 bits-per-centimeter) on the outside track to 3268 bits-per-inch (1286 bits-per-centimeter) on inside track.

Single-density FM recording is most reliable and requires a relatively inexpensive controller consisting of encoding and decoding logic. For example, this IBM-compatible mode, which encodes the digital data into electronics-generated ("soft") sectors, uses simple read and detection clock system without write precompensation.

The FM mode may also record in a format noncompatible with the IBM. Disks with "hard" sectors, identified by punched holes, can store nearly 400K bytes rather than approximately 300K bytes in a single-density compatible mode.

maximum storage capacity

Quite often data storage capacity is more important than IBM-compatibility. In maximum capacity applications, designers could select double-density recording that roughly provides twice the data storage

and transfer rate offered by single-density recording.

This choice leads to making a second decision. Which type of recording mode should the designer call for? At the present time, many floppy disk drives most frequently use two codes — MFM and modified MFM (M^2 FM). (Other techniques are also available, but they require much more complex encoding and decoding logic in the controller). Phase-locked loop type data separators readily decode both codes.

encoding algorithms

All three double-frequency modes, FM, MFM and M^2 FM, encode serial binary information (bits) according to the set of clock-bit and data-bit rules listed in the nearby table and the nearby timing diagrams illustrate how the three encoding schemes relate to each other.

MFM and M^2 FM encoding record data with twice the density as FM with no increase in flux change density. However, to realize double density, the system must use a more expensive and complex write precompensation circuit to overcome bit shift problems. It also requires a more sophisticated (and more expensive) read detection circuit.

The choice between MFM and M^2 FM is not obvious, and you can make a case for either. In fact, some floppy disk drive manufacturers use MFM, while others use M^2 FM, and some offer you a choice of either one. Both modes provide about the same reliability at approximately the same cost. However, the modes are not compatible with each other; a unit that records data on a disk in one mode cannot read information recorded in the other mode.

[Information furnished by Memorex Corp. and PerSci, Inc.]

Buyer's Guide

CASSETTE DRIVE PRODUCT MANUFACTURERS

The cassette drive manufacturers listed here offer full-size cassettes with the exception of Interdyne, which also markets a special cassette called Unireel. Microcommunications only offers a special endless-loop drive called Wafer. Contact manufacturers directly for catalog information or circle the appropriate number on the reader service card.

Electronic Processors, Inc.
1265 W. Dartmouth Ave.
Englewood, CO 80110
(303) 761-8540 Circle 153

Facit-Addo, Inc.
66 Field Point Rd.
Greenwich, CT 06830
(203) 622-9150 Circle 154

Interdyne
14761 Califa St.
Van Nuys, CA 91411
(213) 787-6800 Circle 155

Meca
7344 Wamego Trail
Yucca Valley, CA 92284
(714) 365-7686 Circle 156

Memodyne Corp.
385 Elliot St.
Newton Upper Falls, Ma 02164
(617) 527-6600 Circle 157

Micro Communications Corp
80 Bacon St.
Waltham, MA 02154
(617) 899-8111 Circle 159

Micro Designs, Inc.
Box 2480
Berkeley, CA 94702
(415) 465-1861 Circle 158

Raymond Engineering, Inc.
217 Smith St.
Middleton, CT 06457
(203) 632-1000 Circle 160

Redactron Corp.
100 Parkway Dr. S.
Hauppauge, NY 11787
(516) 543-8700 Circle 161

Triple I
Box 25308
Oklahoma City, OK 73125
(405) 521-9000 Circle 162

CARTRIDGE DRIVE PRODUCT MANUFACTURERS

All of the cartridge drive manufacturers listed here offer full-size cartridges with the exception of Quantex, which offers a mini-cartridge; 3M Data Products offers full-size and minis. Because cartridge drive manufacturers may change their products at any time, we recommend that you check all potential sources of supply for their latest data sheets. For catalog information, either contact the manufacturer directly or circle the appropriate number on the reader service card.

Data Electronics, Inc.
370 N. Halstead St.
Pasadena, CA 91107
(213) 351-8991 Circle 163

National Computer Systems
4401 W. 76th St.
Minneapolis, MN 55435
(612) 831-4100 Circle 164

Mohawk Data Sciences Corp.
Palisade St.
Herkimer, NY 13350
(315) 867-6000 Circle 165

Redactron Corp.
100 Parkway Dr. S.
Hauppauge, NY 11787
(516) 543-8700 Circle 166

Quantex
200 Terminal Dr.
Plainview, NY 11803
(516) 681-8350 Circle 167

Sycor, Inc.
100 Phoenix Dr.
Ann Arbor, MI 48104
(313) 971-0900 Circle 168

Tandberg Data, Inc.
4901 Morens Blvd.
San Diego, CA 92117
(714) 270-3990 Circle 169

3M Data Products
3M Center
St. Paul, MN 55101
(612) 733-8863 Circle 170

DISKETTE DRIVE PRODUCT MANUFACTURERS

The diskette drive manufacturers listed here offer full-sized diskettes with the exception of Micropolis and Wangco, who market only minidiskettes; Pertec and Shugart also offer minidiskettes. Because diskette drive manufacturers may upgrade their products, we recommend you contact all of them for any changes. For catalog information, contact the manufacturer directly or circle the appropriate number on the reader service card.

Applied Data Communications
1509 E. McFadden Ave.
Santa Ana, CA 92705
(714) 547-6954 Circle 171

California Computer Prod.
2411 W. La Palma Ave.
Anaheim, CA 92801
(714) 821-2011 Circle 172

Control Data Corp.
Box 12313
Oklahoma City, OK 73112
(405) 946-5421 Circle 173

Data Systems Designs, Inc.
3130 Coronado Dr.
Santa Clara, CA 95051
(408) 249-9353 Circle 177

Ex-Cell-O Corp. Remex
Box 19533
Irvine, CA 92713
(714) 557-6860 Circle 174

General System Int.
1440 Allec St.
Anaheim, CA 92805
(714) 956-7183 Circle 175

Hewlett-Packard Data Sys.
11000 Wolfe Rd.
Cupertino, CA 95014
(408) 257-7000 Circle 176

Innovex Corp.
75 Wiggins Ave.
Bedford, MA 01730
(617) 275-2110 Circle 178

Memorex Corp.
San Tomas at Central Epwy.
Santa Clara, CA 95052
(408) 987-1000 Circle 179

Micropolis Corp.
9017 Reseda Blvd.
Northridge, CA 91324
(213) 349-2328 Circle 180

PerSci, Inc.
4087 Glencoe Ave.
Marina del Rey, CA 90291
(213) 822-7545 Circle 181

Pertec Computer Corp.
21111 Erwin St.
Woodland Hills, CA 91364
(213) 999-2020 Circle 182

Scientific Micro Systems
777 E. Middlefield Rd.
Mt. View, CA 94043
(415) 964-5700 Circle 190

Shugart Assoc.
415 Oakmead Pkwy.
Sunnyvale, CA 94086
(408) 733-0100 Circle 183

Sykes Datatronics, Inc.
375 Orchard St.
Rochester, NY 14606
(716) 458-8000 Circle 184

Tri-Data
800 Maude Ave.
Mountain View, CA 94043
(415) 969-3700 Circle 185

Wangco, Inc.
5404 Jandy Pl.
Los Angeles, CA 90066
(213) 390-8081 Circle 186

Xebec Systems Inc.
2985 Kifer Rd.
Santa Clara, CA 95051
(408) 988-2550 Circle 187

double-sided floppy disk drive

Shugart Associates, the leading independent (non-IBM) manufacturer of floppy disk drives, announced the introduction of its SA850/851 double-sided single/double density floppy disk drive. Orders for the new units are being taken and deliveries began in May 77, according to Shugart.

The new SA850/851 double-sided floppy stores up to four times the data of a standard floppy drive — or 1600K bytes unformatted and 1200K bytes formatted. The SA 850/851 is available with single density (FM encoding) and double density (M²FM) capability as standard features.

Single quantity price on the drive will be about 26 percent more than the standard Shugart SA800/801 floppy drive — about \$750. OEM quantity pricing will also be about 25 percent more than the SA800/801 floppy drive.

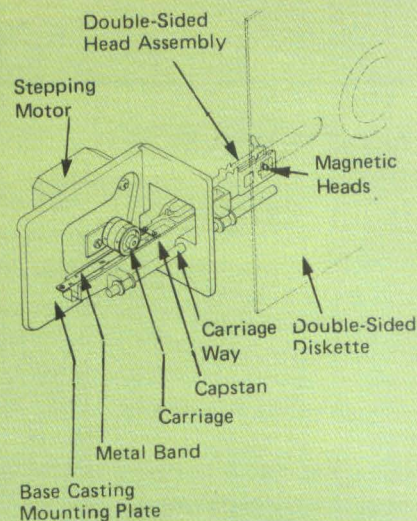

SA850 double-sided floppy disk drive reads and writes data on both sides of a diskette using a double-headed actuating arm. Actuating arm assembly has two metal flexures in which the proprietary Shugart R&W heads are mounted. When actuated by the drive electronics, the top flexure closes onto the diskette making physical contact with it and applying pressure against the lower head for proper data conformity. The read/write heads utilized in the SA850 are the same as those used in Shugart's standard SA800 floppy drives.

Capability comparison

Table 1 lists the important capabilities of the three types of drives. Since the drive technology is changing rapidly, the tabulated values indicate the approximate picture of the moment. Use the table as a rough guide to help you investigate and choose the type of drive you need.

Making the choice.

To choose the drive best suited for a specific application, you should answer these questions:

- Do you need random access or will serial access do?
- How fast must the transfer rate be?
- How reliable is the mechanical part of the drive?
- How reliable are the media?
- How important is the error rate?
- How easily can you file and mail the media?
- Is it important for the drive to be IBM-compatible or ANSI-compatible?
- Is the drive available from a second source or can you substitute another make without a major redesign?
- How do the prices compare?

To illustrate how a designer may use the answers to these questions, let's first assume that you've determined your application needs a full-size diskette drive. First, emphasize mechanical reliability, because usually the electronic reliability is a lesser problem. Remember that a highly reliable floppy disk drive may cost more initially, but can save the user money in the long run by reducing maintenance and down time.

Diskette users most often worry about media interchangeability, reliability, audible noise and media wear. Although interchangeability is related to IBM-compatibility, some drives are more compatible than others. The IBM format is

forgiving enough to cover most drives, but it does not guarantee compatibility between different makes. A world of many types of computer-based systems that talk to each other makes true compatibility very important. Audible noise can create problems in a number of applications, such as in offices and hospitals; in other applications, noise doesn't matter. Since disk wear around the hub and on the read/write surface affects data integrity, the drive must keep wear to a minimum.

the future

Although drive manufacturers will continue to improve their products by making them store more data faster, more reliably than ever, other nonmechanical technologies may begin displacing them. For example, Tandberg Data's Herm Brooks predicts that bubble memories could displace electromechanical recording on magnetic media in a large number of applications. However, bubble memories do not seem to lend themselves to removal from systems for long-term data storage on shelves and then to being returned to the system for readout. He ended his look into the future by noting that digital systems need an ultimate solution to the storing of data — an optical memory that writes and reads at enormous speeds, uses little power, occupies little space — all at a very low cost per bit.

Coming Next Month

A Benwill/Technocast report on patent activity in floppy disk drives.

ADVERTISERS' INDEX

- 48 **ADDMASTER**
Agency: Mich Associates
- 16, 17, 19 **ADTECH POWER**
Agency: William E. Wilson
- 35, 73 **ADVANCED ELECTRONICS DESIGN**
Agency: Art Effects
- 33 **BOSCHERT**
Agency: Peter Edward Lowe
- 84 **BOSTON UNIVERSITY SHOWS**
- 27 **CALIFORNIA COMPUTER PRODUCTS**
Agency: Dailey
- 32 **COMPUTER LABS**
- 87 **COMPUTER OPERATIONS**
Agency: Pallace
- 56 **COMTEC**
Agency: LeBeau, Leicht & Santangini
- 57 **DATA 100**
Agency: Chuck Ruhr
- 31 **DATA SYSTEMS DESIGN**
Agency: Tycker — Fultz
- 87 **DE ANZA**
Agency: Sunshine Associates
- 40, 41 **DIGITAL EQUIPMENT**
Agency: Creamer/Fsr
- 82 **EAGLE — PICHER**
Agency: Adventures
- 83 **EDUCATIONAL DATA SYSTEMS**
Agency: Sylvester
- 6 **EPSON AMERICA**
Agency: Sylvester
- 48 **FAIRCHILD WORLD MAGNETICS**
- C-2 **GENERAL SYSTEMS**
Agency: LaMantia
- 8 **GULTON INDUSTRIES**
Agency: AC
- 46, 47 **HEWLETT-PACKARD**
Agency: Tallant/Yates
- 49 **HOUSTON INSTRUMENT**
Agency: Cooley & Shillinglaw
- 62 **INDUSTRIAL ELECTRONIC ENGINEERS**
Agency: Olympus
- 9 **ISS/SPERRY UNIVAC**
Agency: LaCentra
- 60, 61, 77 **KERONIX**
- 58 **LAVEZZI MACHINE WORKS**
Agency: Joseph Bosco
- 36, 37 **3M/MIDCOM/DATA**
Agency: Martin/Williams
- 85 **MDB SYSTEMS**
Agency: Sunshine Group
- 79 **MICROCOMMUNICATIONS MIDCOM '77**
Agency: Frederick Walsh
- 43 **MITS**
Agency: Agency
- 1 **MUPRO**
- 10, 11 **NATIONAL SEMICONDUCTOR**
Agency: Chiat/Day
- 45 **NCR**
Agency: Faller Klenk & Quinlan
- 78 **OK MACHINE & TOOL**
Agency: Camen
- 75 **OVENAIRE**
Agency: John M. Bunch
- 28, 29 **PERTEC**
Agency: Boylhart, Lovett & Dean
- 7 **POLYMORPHIC SYSTEMS**
Agency: Peterson
- 66 **PORELON**
Agency: Franklin/Mautner
- 13 **PRINTRONIX**
Agency: William E. Wilson
- C-4 **ROLM**
Agency: McArthur Associates
- 15 **SC ELECTRONICS**
Agency: Audiotronics
- C-3 **SYSTEM INDUSTRIES**
Agency: Associated Ad*Ventures
- 64 **SYSTRON-DONNER/Concord Instrument Div.**
Agency: Fred Schott
- 2, 3 **TANDBERG DATA**
Agency: Grant & Millard
- 4 **TEC**
Agency: TEC-Ad
- 65 **TELETYPE**
Agency: N.W. Ayer
- 59 **TEXAS INSTRUMENTS**
Agency: Glenn Bozell & Jacobs
- 63 **THOMPSON**
Agency: Kotula
- 66 **TRIPLE I**
Agency: Adpub Associates
- 81 **VICTOR BUSINESS PRODUCTS**
- 58 **WILSON LABS**
Agency: Sylvester

SALES OFFICES

PUBLISHER Yuri Spiro

MARKETING PROGRAMS DIRECTOR Irwin Stern

NEW ENGLAND George Palken 167 Corey Road, Brookline, MA 02146 (617) 232-5470 **NEW YORK, WASHINGTON DC, PHILADELPHIA** Wes Schneider 30 P Village Green, Budd Lake, NJ 07828 (201) 347-7920 **MIDWEST, SOUTH** Ralph Petersen 1 Wheaton Center, No. 1706, Wheaton, IL 60187 (312) 653-2480 **LOS ANGELES, PHOENIX, DALLAS, SAN FRANCISCO** Alan Cazier 823 Enchanted Way, Pacific Palisades, CA 90272 (213) 454-0624 **WEST GERMANY** Maurice A. Coates Int'l. Media Reps. D-675 Kaiserlautern, Box 1610 **JAPAN** Hiro H. Irie International Business Corp. 11-8 Narita -Higashi 1-Chome, Sugunami-KU, Tokyo 166 Phone: (03) 311-1746.



Assembling The No-Language: Another Proposal

Last month, I cited two problems that circuit designers face when attempting to use microprocessors: There's no simple way to tell the microprocessor what to do next, and there's no simple way to keep track of register numbers. I proposed that to help solve the first problem, microprocessor users utilize the "no-language" contained in the "operation," "functions," "description" or "Boolean arithmetic operation" column of a microprocessor's instruction set. I also proposed developing a special keyboard to deal with the language.

What about the second problem? Computer people have solved it, too, for systems in which mnemonic codes are loaded into a microcomputer through a terminal. They call the solution "assembling," "calculation and assignment of absolute addresses," "symbolic addressing," "relative addressing" and "labels." An assembler program keeps track of register numbers once a programmer assigns a register to a program's first line.

Commercially, this solution results in microprocessors manufacturers' "program development systems" that cost several thousand dollars; from such manufacturers' view such systems are great — they lock a customer into one chip or one chip family. Once having bought such a system, a user probably won't switch to a competitive chip because such a switch means writing off a sizeable investment.

We need, therefore, an assembler program that works with hex keyboards or with the programming keyboard I proposed last month; such assembler for use with a hex keyboard is available today. With such an assembler, a programmer could assign number labels to registers or operations referred to in a program and then could direct an operation to proceed to a desired label regardless of its register number.

I propose we let such an assembler do all our address calculating. The job has already been done for the programs written in mnemonic code; we can use the expertise developed for that task to provide such an assembler for microprocessor machine code and for no-language engineering symbols.

Karl V. Amatneek

Karl V. Amatneek is president of KVA Associates, Wyndmoor, PA, consultant at Hahnemann Medical College, Philadelphia, and chairman of the Philadelphia IEEE section's Committee on Professional Update. We will be pleased to provide space for opposing views.

Now you can get our disk systems within 30 days ARO at the industry's lowest prices:

- 80 Mbytes for under \$12K*
- 300 Mbytes for under \$20K*

Field-proven reliability, total software support and 30-day delivery. You've come to expect them all from us. And that's why we've become the world's largest independent supplier of minicomputer disk storage systems.

Now add low price. Lower than the minicomputer manufacturer, lower than any other independent—the lowest in the industry. Why? Because we buy more disk drives than anyone else, and we can afford to pass the OEM discounts on to you.

The prices listed above are for complete disk systems ready to plug into your minicomputer. Each system includes our high-performance controller, an appropriate minicomputer interface and the software of your choice.

When you buy disk systems from us, you'll save a lot more than a lot of money on the purchase price. You'll save precious time. Beginning with our 30-day delivery and continuing with our responsive, customer/software support, we'll get your system up quickly—and keep it up. For complete OEM pricing information and technical details, contact the System Industries representative in your area.

System Industries

An equal opportunity employer.

535 Del Rey Avenue
Sunnyvale, California 94086
(408) 732-1650, Telex 346-459

* OEM prices: 40-69 systems.

Sales/Service Representatives

Boston: (617) 492-1791. **New York:** (201) 461-3242; (716) 385-3021; (516) 299-4272; (201) 694-3334.
Washington, D.C.: (202) 337-1160. **Cincinnati:** (513) 661-9156. **Los Angeles:** (714) 752-8904. **Houston:** (713) 465-2700.
Sunnyvale HQ: (408) 732-1650. **Canada:** (416) 624-0320. **United Kingdom:** (4862) 70725.
Germany: 211-407542. **Sweden:** 08-236640. **Spain:** 45-7-5312.

NOW DELIVERING

A Half Million Word Computer

A Whole Line of Peripherals & Software



THE ROLM 1666. Memory expansion to 576K words. Transparent mapping into 64K blocks for six users. Four-way memory protection. Privileged instructions with I/O allocation & protection.



THE PACKAGE. Complete selection of peripherals. Both military & commercial specs. Fully integrated & documented. Supported by a wide range of systems software including RMX/RDOS.

That's Why We're #1 in Mil-Spec Computer Systems

ROLM

MIL-SPEC
Computers

4900 Old Ironsides Drive, Santa Clara, CA 95050. (408) 988-2900. TWX 910-338-7350.

In Europe: 645 Hanau, Muehlstrasse 19, Germany, 06181 15011, TWX 418-4170.

CIRCLE 3

THE GEORGE E. FREEMAN LIBRARY
STATE TECHNICAL INSTITUTE AT MEMPHIS
5983 Macon Cove at Interstate 90
Memphis, Tennessee 38134