

Welch Allyn Non-Masted Scales

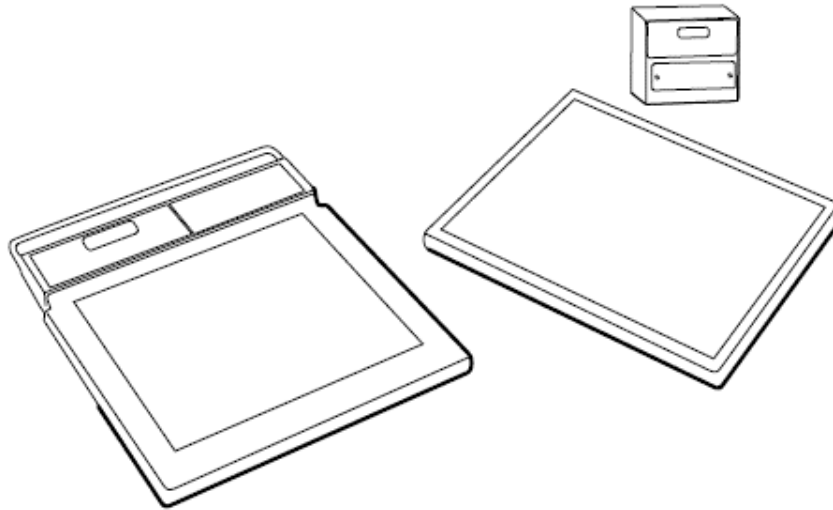

Service Manual

Model 5102 Physician's Stand-On Scale

Model 5125 Portable Stand-On Scale

Model 5127 Bariatric Portable Stand-On Scale

WelchAllyn[®]

Advancing Frontline Care™

© 2016 Welch Allyn. All rights are reserved. To support the intended use of the product described in this publication, the purchaser of the product is permitted to copy this publication, for internal distribution only, from the media provided by Welch Allyn. No other use, reproduction, or distribution of this publication, or any part of it, is permitted without written permission from Welch Allyn. Welch Allyn assumes no responsibility for any injury to anyone, or for any illegal or improper use of the product, that may result from failure to use this product in accordance with the instructions, cautions, warnings, or statement of intended use published in this manual.

Software in this product is Copyright 2016 Welch Allyn or its vendors. All rights are reserved. The software is protected by United States of America copyright laws and international treaty provisions applicable worldwide. Under such laws, the licensee is entitled to use the copy of the software incorporated with this instrument as intended in the operation of the product in which it is embedded. The software may not be copied, decompiled, reverse-engineered, disassembled, or otherwise reduced to human-perceivable form. This is not a sale of the software or any copy of the software; all right, title, and ownership of the software remain with Welch Allyn or its vendors.

For information about any Welch Allyn product, contact your local Welch Allyn representative:
<http://www.welchallyn.com/en/other/contact-us.html>

DIR 80021779 Ver. A
Revision date: 2017-03



Welch Allyn, Inc.

4341 State Street Road
Skaneateles Falls, NY 13153 USA
www.welchallyn.com

Customer Support

Placing orders, checking on pricing, billing, or repairs
scale-tronix@welchallyn.com

1.800.535.6663, Option 2, 1, 5
9am - 5pm EST
Mon - Fri

CONTENTS

Custom setup	4
Enter custom setup mode.....	4
Set the options.....	4
Enter Advanced Service Mode.....	7
Menu List for Advanced Service Mode	7
Support Services	8
Warranty.....	8
Repairs	8
Returning products	9
Warranty service.....	9
Non-warranty service.....	10
Maintenance of Scales	10
Battery replacement	10
Calibration of Scale	10
Calibration Procedure	11
Troubleshooting of Scale	12
Symptom and Solutions.....	14
Disassembly Guide	17
Required Tools:	17
Specified Torque Values.....	17
5125 & 5127 Disassembly	18
5102 Disassembly.....	27
Repair Parts List	34
5125 & 5127 Repair Parts List.....	34
5102 Repair Parts List	35
Schematics	36
5125/5127 Schematics.....	36
<i>5102 Schematics</i>	41

Custom setup

You can customize the scale to best suit your needs. Configurations that can be selected include the automatic shut-off time, weighing units (if available), weight resolution, and more.

Enter custom setup mode

1. Make sure the scale is powered down.
2. Press and hold **ST** while pressing **ON**.
3. Once the scale powers up, press and release **ST** five times. The scale displays **SEt-UP** and produces a series of four long beeps.
4. The "RE CALL" pushbutton is used to select the particular option value.
5. Once this value is selected the scale can be advanced to the next option by again pressing the "ST" pushbutton or it can be shut-off by pressing and holding the "ON" pushbutton.

Set the options

Enter the custom setup as described.

Press **ST** to scroll through the custom setup options.

The options displayed with each press are as follows:

Press the setup mode select button to turn these options **On** or **OFF**.

Note Options indicated with an asterisk (*) require an additional press of **ST** to change the value.

Option displayed Feature

SOft This option displays the software version of your scale.

dAtE This option displays the release date of the software. The format is MM/DD/YY.

SCALE This option displays the model number of the scale.

AutOFF* This displays the number of seconds before the scale turns off. The **Cont** value prevents the scale from turning off automatically.

AC con* This option causes the scale to remain on when plugged in to AC power.

rES This option allows you to change the resolution of weight. Pressing **ST** switches between the following options:

- 0.1 pounds / 0.05 kilograms
- 0.1 pounds / 0.1 kilograms
- 0.2 pounds / 0.1 kilograms
- 0.5 pounds / 0.2 kilograms
- 1 pound / 0.5 kilograms

Units* This option allows you to change the displayed weight unit.

Note: Do not change the scale units if you have purchased the kilogram-only option.

KILOS* This option allows the weight to display in kilograms.

POUNDS* This option allows the weight to display in pounds.

bEEPEr* This option determines the audible signal that occurs when a front panel button is pressed.

rECALL* This option allows you to turn **ON** or **OFF** the **RECALL** button functionality.

rS-232 Detailed instructions for this feature are available from Welch Allyn. Go to <http://www.welchallyn.com/en/other/contact-us.html> to find your local representative.

OutPut* This option displays the current data port output option. Detailed instructions for this feature are available from Welch Allyn. Go to <http://www.welchallyn.com/en/other/contact-us.html> to find your local representative.

Set the value to **OFF** to disable the optional internal printer or the RS-232 port.

PrtUnt* This option determines whether pounds or kilograms are displayed on a printout.

If the pounds and kilograms indicators are illuminated on the control panel, the printed output is determined by whichever unit is selected on the control panel.

If the kilogram indicator is illuminated, it will only print in kilograms, regardless of the unit selected on the control panel.

If the pounds indicator is illuminated, it will only print in pounds, regardless of the unit selected on the control panel.

PrtOPT* Press **RECALL** to choose between the following options:

PnlPrt: The current weight is printed when **PRINT** is pressed on the control panel.

AutPrt: The current weight is automatically printed when a weight reading occurs.

bAud* This option allows you to set the baud rate. Values are 1200, 2400, 4800, 9600, and 19200.

pArity* This option allows you to change the parity between the following options:

Off: No parity, 8 data bits

Odd: Odd parity, 7 data bits

EuEn: Even parity, 7 data bits

StPbit* This option allows you to change the stop bits between the following options:

1 bit: One stop at the end of a word

2 bits: Two stops at the end of a word

rts.cts* This option allows you to turn **On** or **Off** the handshaking hardware for serial transmissions.

Prtbtn* This option allows you to turn **On** or **Off** the front panel **PRINT** button.

rtEPrt* This option allows you to turn **On** or **Off** the enabling of printing from a remote location by connecting the receive line to the ground.

PC brd This option displays the model number of the printed circuit board. A second press of **ST** displays the revision of the printed circuit board.

SEt-UP This option is displayed when you have cycled through all the options. Press and hold **ON** to power down the scale.

Enter Advanced Service Mode

1. To enter the "service" mode start with the scale turned off.
2. Note the small "ST" logo ("**ST**") located directly above the "**RE CALL**" pushbutton, and below the "**ZERO**" pushbutton on the front panel of the readout.
3. This "**ST**" actually contains a small hidden pushbutton.
4. Next; press and hold this "**ZERO**" pushbutton on the front panel while turning the power on with the "**ON**" pushbutton.
5. As soon as the scale turns on release the "**ZERO**" pushbutton, then quickly press and release "**ST**" logo pushbutton 5 times.
6. The scale will display "**SERVICE**" and produce a series of four long beeps.
7. "Service" mode has now been entered.
8. Pressing the "**ST**" pushbutton will advance the display to the next item.
9. The scale will exit the service mode automatically after 3 minutes, or can be shut-off by pressing and holding the "**ON**" pushbutton for 3 or 4 seconds.
10. When the scale is turned back on, normal scale operation will resume.

Menu List for [Advanced Service Mode](#)

1. "**A/D**", and next window on display will show the raw A/D reading. As you press on the Platform the A/D reading will change. The weight change reading should be positive proportionally with the applied weight in pounds.
2. "**Test**", and the next window will start displaying the display test, Number will show across from 0 to 9 and repeat w/ DP, from right side to left side.
3. "**Pr-Ons**" = Power on start-up, next display will show the number of times the "**ON**" pushbutton has been depressed.
4. "**Pr-rcf**" = Powered by Recall, next display will show the number of times the "**RECALL**" pushbutton has powered-up the scale (from an off state).
5. "**COUnts**" = Weighing Counts, next display will show the number of times a weight reading has been achieved.
6. "**rEcntS**" = Reweigh counts, next display will show the number of times "**REWEIGH**" pushbutton has been depressed.
7. "**rECLLS**" = recalls, next display will show the number of times the "**RECALL**" pushbutton has been depressed.
8. "**OFFS**" = Turned Off, next display will show the number of times the scale has been turned off by holding the "**ON**" pushbutton down.
9. "**Prints**" = Prints, next display will show the number of times the "**PRINT**" pushbutton has been depressed.
10. "**SEtUPS**" = set-up mode, next display will show the number of times the unit has entered into the set-up mode.
11. "**SEruES**" = service mode, next display will show the number of times the unit has entered into the service mode.
12. "**CALS**" = Cal mode, next display will show the number of times the unit has entered into the Cal mode.

Support Services

If you have a problem with the device that you cannot resolve, call the Welch Allyn Technical Support Center nearest you for assistance. A representative will assist you in troubleshooting the problem and will make every effort to solve the problem over the phone, potentially avoiding an unnecessary return. Technical support is available 9am-5pm EST.

Welch Allyn offers the following technical support services:

- Telephone support
- Replacement service parts
- Product service

For information on any of these services, go to <https://www.welchallyn.com/en/service-support.html>

Warranty

Welch Allyn will warranty the weight scale to be free of defects in material and workmanship and to perform in accordance with manufacturer specifications for the period of one year from the date of retail purchase.

The warranty period shall start on the date of purchase. The date of purchase is: 1) the invoiced ship date if the device was purchased directly from Welch Allyn, 2) the date specified during product registration, 3) the date of purchase of the product from a Welch Allyn authorized distributor as documented from a receipt from said distributor.

This warranty does NOT cover damages caused by misuse or abuse, including but not limited to:

- Failure caused by unauthorized repairs or modifications
- Damage caused by shock or dropping during transportation
- Damage caused by improper use of the power supply
- Failure caused by improper operation not consistent with the instructions stated in the *Directions for use*

Should this device require maintenance (or replacement at our option) under warranty, contact your local Welch Allyn representative: <http://www.welchallyn.com/en/other/contact-us.html>

Repairs

A Welch Allyn Service Center or Authorized Service Provider must perform all repairs on products under warranty unless performed by a properly certified technician.

CAUTION Unauthorized repairs will void the product warranty.

Qualified service personnel or a Welch Allyn Service Center should repair products out of warranty.

If you are advised to return a product to Welch Allyn for repair or routine maintenance, schedule the repair with the service center nearest you.

Returning products

When returning a product to Welch Allyn for service, ensure that you have the following information:

- Product name, model number, and serial number. This information may be found on the product and serial number labels.
- A complete return shipping address.
- A contact name and phone number.
- Any special shipping instructions.
- A purchase-order number or credit-card number if the product is not covered by a warranty.
- A full description of the problem or service request.

1. Obtain an RMA number. Contact Welch Allyn and request.

Note Welch Allyn does not accept returned products without an RMA.

2. Ship the device to Welch Allyn, observing these packing guidelines:

Remove from the device the battery, all hoses, connectors, cables, sensors, power cords, and other ancillary products and equipment, except those items that might be associated with the problem.

Dispose of damaged or leaking batteries in an environmentally safe manner consistent with local regulations.

Note: To ensure safe receipt of your device by the service center and to expedite processing and return of the device to you, **thoroughly clean all residues from the device before you ship it to Welch Allyn.** For cleaning requirements, see the Cleaning instruction in the Directions for Use.

Welch Allyn thoroughly cleans all returned devices on receipt, but any device that cannot be adequately cleaned cannot be repaired.

3. Write the Welch Allyn RMA number with the Welch Allyn address on the outside of the shipping carton.

Warranty service

All repairs on products under warranty must be performed or approved by Welch Allyn.

Refer all warranty service to Welch Allyn Product Service or another authorized Welch Allyn Service Center.

Obtain a Return Material Authorization (RMA) number for all returns to Welch Allyn Product Service.

CAUTION Unauthorized repairs will void the product warranty.

Non-warranty service

Welch Allyn Product Service Centers and Authorized Service Providers support non-warranty repairs. Contact any Welch Allyn regional service center for pricing and service options.

Welch Allyn offers modular repair parts for sale to support non-warranty service. This service must be performed only by qualified end-user biomedical/clinical engineers.

Maintenance of Scales

Routinely perform the following preventive maintenance to keep your scale in working order.

1. Check the calibration annually or as required.
2. Inspect the scale for cracks or loose mounting hardware. Replace or repair as necessary.
3. Visually inspect the scale enclosure for damage or loose or missing hardware. Replace or repair as necessary.
4. If equipped, inspect the AC line cord for abrasions or other signs of wear if equipped.
5. Do not expose the scale to excessive water or moisture.
6. Do not store the scale where heavy objects can be placed on it.
7. Replace the batteries annually or as required.
8. Do not service or perform maintenance while the scale is in use with a patient.

Battery replacement

CAUTION Use only size C disposable alkaline batteries. The use of any other battery will void the warranty.

1. Using a screwdriver, remove the two battery access door screws located on the right of the display (5102 is below display) and remove the door.
2. Install new batteries in the battery holder. Make sure to follow the polarity instructions.
3. Re-attach the access door.

Calibration of Scale

Your scale has been carefully calibrated at the factory. This calibration involves matching and tuning of the load cells and readout electronics. The scale calibration should be checked annually. Only use calibrated, certified scale test weights for this purpose. Traction or physical therapy weights are **NOT** acceptable since their actual weight can often be in error as much as +/-10%. Calibration weights may be purchased from **WELCH ALLYN** or a local scale dealer. An alternative to calibration weights is the weight comparison method. This requires a known accurate, calibrated scale. A fixed weight is "weighed" on the calibrated scale then the same weight is placed on the scale for comparison.

TEST CALIBRATION WEIGHTS ARE AVAILABLE FROM WELCH ALLYN.

THREE (3) 25 KILOGRAM TEST WEIGHTS ARE RECOMMENDED.

ORDER PART NO. 20021W. (25 KG TEST WEIGHTS)

Large changes in calibration often indicate a damaged load cell or faulty readout component. It is generally recommended that if calibration is necessary for your scale it should be returned to the factory. Calibration should not be attempted by those not having the proper tools or knowledge of electronic systems and their attendant shock hazards.

Calibration Procedure

Enter the "calibration mode" by following **exactly** the procedure outlined below:

1. Verify serial number labels on Readout Assembly, & Base Assembly match.
2. Be sure scale is off.
3. Press and hold in the "RE WEIGH" pushbutton.
4. While pressing the "RE WEIGH" pushbutton, press and release the "ON" pushbutton.
5. NOTE: The "ST" pushbutton is a special hidden programming and test pushbutton located under the **WELCH ALLYN** logo ("ST") on the left side of the front panel between the "ZERO" and "RE CALL" pushbuttons. After the scale displays the test pattern of "888888" release the "RE WEIGH" button and press the "ST" pushbutton five (5) times. This will cause the readout to enter the calibration mode. The display will indicate "CAL".
6. Press the "ST" pushbutton once more; the display will indicate "A/D". This indicates the start of the "raw" analog-to-digital converter data being inputted to the microprocessor.
7. Press the "ST" pushbutton one more time. The number displayed is now the raw analog to digital data.
8. The automatic turn-off timer has also been programmed for an extended "on" period to give you time to calibrate the scale. This time period is three minutes. The scale may be turned off before this time period by simply pressing and holding the "ON" pushbutton. Hold it in for several seconds until the power shuts off. If additional time is needed to complete the calibration procedure, press the "ON" pushbutton briefly. This will reset the timer for an additional three minutes.

The readout is displaying a number, which represents the ZERO offset value of the platform and load cell transducers, in tenths of pounds (0.1 pound). Note and record this value. (Even though your scale may be "kilograms only" in operation, pounds are used internally because of their finer resolution.) Units conversion is as follows:

1.0 kilogram = 2.2 (2.2046) pounds
5.0 kilograms = 11.0 (11.0231) pounds
10.0 kilograms = 22.0 (22.0462) pounds
25.0 kilograms = 55.1 (55.1156) pounds
50.0 kilograms = 110.2 (110.231) pounds
75.0 kilograms = 165.3 (165.347) pounds
100 kilograms = 220.4 (220.462) pounds

Add the specified test weight to the platform. Note the new number displayed. Subtract the original ZERO offset value from this new number to obtain the scale's displayed value of the calibration weight.

NOTE: Early versions of the software did not display the decimal point in the A/D mode, i.e.: 11.7 pounds is displayed as "117".

Example: The ZERO offset value is “11.7” (representing 11.7 pounds). Adding the specified three 25-kilogram test weights (equivalent to 165.3 pounds) to the platform produces a reading of “177.1” The difference is $177.1 - 11.7 = 165.4$ (equivalent to 165.4 pounds). This would indicate the calibration is 0.1 pound “high”.

Using the specified three 25-kilogram test weights, a difference of 165.3 +/-0.1 pound should be obtained. If necessary, adjust potentiometer P1 (span adj.) on the instrument board until the correct value is obtained. Remove the test weight and recheck the ZERO offset value. Note that adjusting P1 may also alter the ZERO offset value. Repeat the process as necessary to obtain the correct difference.

Now you may turn the scale off by pressing the “ON” pushbutton and holding it in for a few seconds. That will force it to turn off. You may also wait for it to time out and turn off by itself.

DATA OUTPUT (RS232) DETAILS

For detailed help and information regarding the data output capabilities, contact **Welch Allyn**. RS232 data output has been made a standard feature on many of our scales in 2013. Existing scales can be easily modified to provide data output when needed. Consult Welch Allyn for details.

Troubleshooting of Scale

The internal microcomputer contained in the readout constantly monitors the scale’s operation and uses the display to indicate error conditions when they arise. An explanation of these messages is given below:

- **“bAttrY”**: Indicates the battery has become depleted to the point that it can no longer operate the scale. Replace the battery to continue operation.
- **“O-LOAD”**: Shows that the scale platform’s weighing capacity has been exceeded. Refer to the inside front cover specifications for maximum capacity.
- **“CABLE”**: Displays that the transducer signal is well in excess of its maximum value. This is usually caused by the transducer cable being disconnected. Check the cable connection between the display and the weighing platform.
- **“OFF SCALE, PLEASE –”**: Remove the weight from the weighing platform and allow the scale to obtain “ZERO”.
- **“E-FAIL”, “r-FAIL”**: Shows that a memory failure has occurred in the internal microcomputer’s memory. Requires service of the scale.

The following simplified trouble shooting procedures are recommended for identifying defective system components. Certain corrective measures are provided. More complicated servicing should only be performed by the factory or authorized service facilities. Most problems can be solved over the telephone. Problems requiring factory service are usually handled quickly and the scale is on its way back. Call first to discuss the problem.

WEIGHT READING NOT ACCURATE

This can commonly be caused by a mechanical obstruction of the weighing platform. Check that the platform is not touching some foreign object so that it is restricted in its’ downward movement. Also check that the connecting cable is firmly plugged into the instrument circuit board (marked “J4 LOAD CELL”).

WEIGHT READING TAKES EXCESSIVE TIME TO DISPLAY

If the platform is in motion, the scale will wait for it to settle before displaying the weight. This can be caused by excessive patient motion.

Also check that the connecting cable is firmly plugged into the readout cabinet. Examine the weighing platform that it is not rubbing against a foreign object.

SCALE DISPLAYS “CABLE” OR “O-LOAD”

This indicates the scale’s internal microcomputer has received a signal in excess of its expected value. “**O-LOAD**” indicates the weight signal is larger than the maximum value assigned to that particular model (see specifications on inside front cover). If the weight value is within the specified range, this indicates a damaged transducer or defective instrument board.

The “**CABLE**” display indicates a signal outside the range of the internal A/D converter has been applied. This is most likely caused by a damaged or disconnected transducer cable. On those scales with a mast, check the connection to the weighing platform at its base. Also check the internal connection of the four wire cable to the “**J1 LOAD CELL**” connector.

READING DOES NOT CHANGE WHEN WEIGHT APPLIED

Check that the weight platform is plugged into the readout. The platform cable, connector or load cell transducer may be defective. The load cell transducer’s resistance can be checked with an ohmmeter after unplugging from the readout. The proper resistance values are listed below:

WIRE COLORS (PIN NO.)	RESISTANCE
GRN(1)/BLK(2)/WHT(3)/RED(4)	>10M Ω
GRN(1) TO BLK(2)	350-450 Ω
WHT(3) TO RED(4)	325-375 Ω

Consult Welch Allyn if readings differ from those shown.

NOTE: Ohmmeters will not indicate a change in resistance of the load cell transducer when weights are applied to scale. This is due to the extremely small change in resistance of the strain gauges employed (<1 ohm) and the fact that the bridge configuration presents a constant value of resistance when measured from its terminals.

NON-FUNCTIONING KEYS(S)

Check the front panel keyboard for visible signs of damage (punctures, dents, etc.). Check that keyboard tail with connector is properly inserted into the display board.

If a particular function does not work (example” no kilogram units) check if that particular function is turned off in the “**SET-UP**” mode.

ERROR MESSAGE DISPLAYED: “E-FAIL” OR “r-FAIL”

This indicates a failure of the internal microcomputer’s memory during the start-up self-test. “**E-FAIL**” indicates a failure of the microcomputer’s eeprom memory during the checksum test. “**r-FAIL**” shows a failure of the random access memory. Both conditions require replacement of the microcomputer.

Symptom and Solutions

Symptom	Possible Cause	Corrective Action
Scale does not turn on	Dead Batteries or no rear Adapter	Replace Batteries (Alkaline "C" Cells)
	Faceplate	Remove Front Panel. Check to make sure the Black and Red cable connector is in place. Replace the switch assembly or the Battery Holder Assembly.
	Cracked Battery Holder	
	Display Board/Main board	Replace the board
Inaccurate Weights, Scale not weighing correctly, scale broken, drifting	Load Cell/Calibration	(OHM out Load Cells) See Calibration procedure this Service Manual
	Bad A/D Chip	<p>Removing the top plate, the load cells will be visible</p> <ol style="list-style-type: none"> 1. Enter into "Cal Mode" from the front panel 2. Press and hold the Reweigh button 3. Turn the Scale on 4. Release the Reweigh button immediately 5. Immediately go to the ST logo and press 5 X 6. Display should say "CAL" 7. Press ST Logo two more times to display A/D Readings <p>Note: A/D reading without a load. Look for a low stable weight reading less than 10 lbs and that is not drifting or unstable.</p> <p>Unplug each load cell and connect one at a time to see if your display becomes unstable. This will tell you which load cell needs to be replaced</p>
	Cold Solder on the Calibration Plug	Check Gain Resistor R24 on the Cal Chip, Replace Cal chip if necessary.

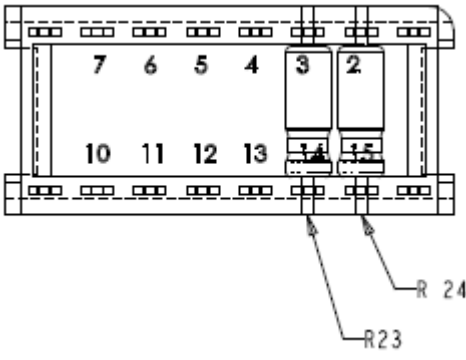
Symptom	Possible Cause	Corrective Action						
		 <table border="1" data-bbox="706 745 1414 819"> <thead> <tr> <th>ASSEMBLY MATERIAL</th> <th>LOCATION</th> <th>RESISTOR VALUE</th> </tr> </thead> <tbody> <tr> <td>255019</td> <td>R24</td> <td>10.0K 1% 1/8W</td> </tr> </tbody> </table>	ASSEMBLY MATERIAL	LOCATION	RESISTOR VALUE	255019	R24	10.0K 1% 1/8W
ASSEMBLY MATERIAL	LOCATION	RESISTOR VALUE						
255019	R24	10.0K 1% 1/8W						
Numbers are not lighting up (Missing Segments of the Numbers)	LED	Remove the Display Board (see directions above) <ol style="list-style-type: none"> 1. Gently, lift a working 7 Segment LED chip with a flat head screw driver and exchange with a non-working LED chip. 2. IF the trouble follows the LED chip replace the chip 3. IF the trouble stays in the socket replace the display board. 						
	Display Board	Replace Display Board						
	Main Board	Replace Main Board						
Only displays Scale Model #	Bad A/D Chip	U10 Microprocessor not communicating U6 Check to make sure the U6 and U10 chips are seated all the way. Replace the Main Board if necessary.						
Letters or Numbers across the Display	IC Chips may be loose	U1 on the Display Board – Reseat the IC chip (U1) on display or replace Display board						

Symptom	Possible Cause	Corrective Action
Weight Remains the same	Memory Chip or Microprocessor	U9 and EM1033 or Microprocessor – Replace the Main Board
Any other Error Modes	Main board, Display Board, Load Cell	Repair, replace as needed

Disassembly Guide

Required Tools:

- 1/8" Allen wrench
- 5/32" Allen wrench
- 3/8" wrench
- 7/16" wrench
- 3/8" socket
- 7/16" socket
- 11 mm socket
- Ratchet socket driver
- #1 Phillips screwdriver
- Slotted screwdriver
- 1/8" slotted screwdriver

Specified Torque Values

Screw Description	Installation Material	Torque Specification	Bit Type
¼-20 x 1/2 BHSC	Aluminum	30.0 in-lbs. max.	5/32" Hex

5125 & 5127 Disassembly

Note: Reassembly is reverse of Dis-Assembly

Note: Whenever the scale is opened for repair purposes a Calibration must be performed.

1. Make sure that the scale is powered down by observing the readout screen. If the screen is empty, it is off. If not, wait for approximately 45 seconds for the scale to shut down.







2. Use a #1 Phillips screwdriver to unscrew the two screws, remove the battery access door and the batteries.



3. Flip the scale over to access the bottom of the scale. Peel the gray tape from each corner half way or until the four nuts underneath are visible.



<p>4. Use a 11 mm socket to remove the four corner nuts.</p>	
<p>5. Flip the scale back and pull the slider deck away from the main body to access the inside of the scale.</p>	
<p>6. Use a 1/8" Allen wrench to unscrew the two screws on the side of the readout cover.</p>	
<p>7. Pull the readout cover apart from the slider deck.</p>	

8. Use a #1 Phillips screwdriver to unscrew and remove the four screws from the circuit board.



9. Unplug the white connector with two black wires and one red wire from the circuit board.

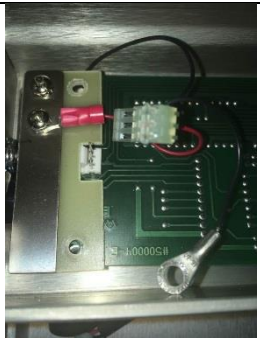

10. Remove the blue ribbon cable and black ribbon cable from the readout circuit board. If the connector is too tight, use a flat-head screwdriver to gently push the connector out of the port.

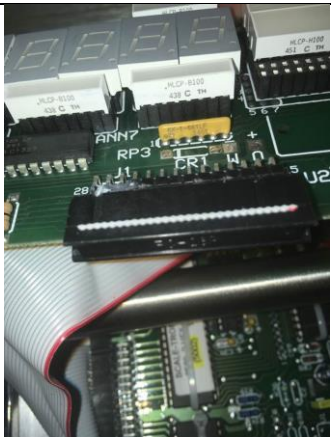

11. Remove the circuit board from the scale body.



12. Use a 7/16" wrench to remove the two nuts on the back of the handle screws.

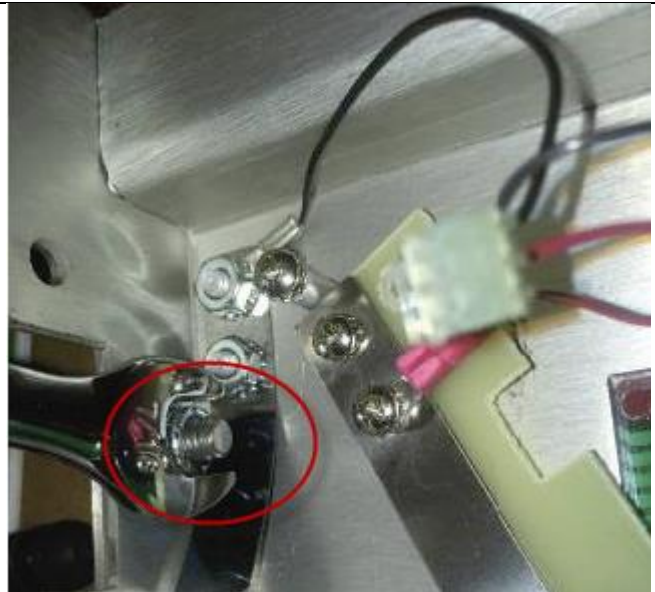

13. Use a 5/32" Allen wrench to remove the two screws on each side of the handle.



14. Remove the handle to access the main body of the scale.



15. Use a #1 Phillips screwdriver to unscrew and remove the four screws from the battery holder.



16. On the instrument board, unplug the J1 power connector.



17. Unplug the J14 RS 232 connector.

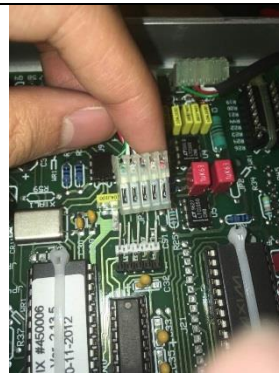

18. Unplug the J4 load cell connector.





19. Using a #1 Phillips screwdriver, unscrew and remove the four corner screws on the instrument board and remove the main circuit board.

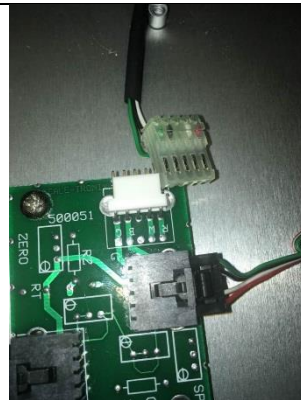

20. Unplug the clear connector from the junction board by pulling it off from the white port.

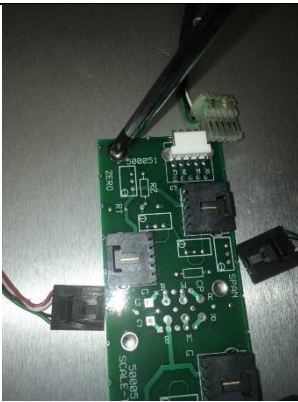

<p>21. Unplug the black connectors from the junction board by pressing the black switch on the connectors and slowly pull it out from the port.</p>	
<p>22. Using a #1 Phillips screwdriver, unscrew and remove the two screws on the upper left and lower right corner of the junction board.</p>	
<p>23. Remove the junction board.</p>	
<p>24. Using a 5/32" Allen wrench, remove each load cell's four screws.</p>	

25. Remove the load cells from the load beam spacer.







26. Using a 3/8" wrench, unscrew and remove the two nuts from the load beam spacer.



5102 Disassembly

Note: Reassembly is reverse of Disassembly

Note: Whenever the scale is opened for repair purposes a Calibration must be performed.

<p>1. On the wall mount readout, use a #1 Phillips screwdriver to remove the two screws of the battery panel cover</p>	
<p>2. Remove the six Duracell batteries</p>	
<p>3. Using a 1/8" Allen wrench, remove the two screws on each side of the readout</p>	
<p>4. Remove the readout from the wall bracket</p>	

5. Pull the readout cover panel from the readout



6. Unplug the J14 RS 232 connector

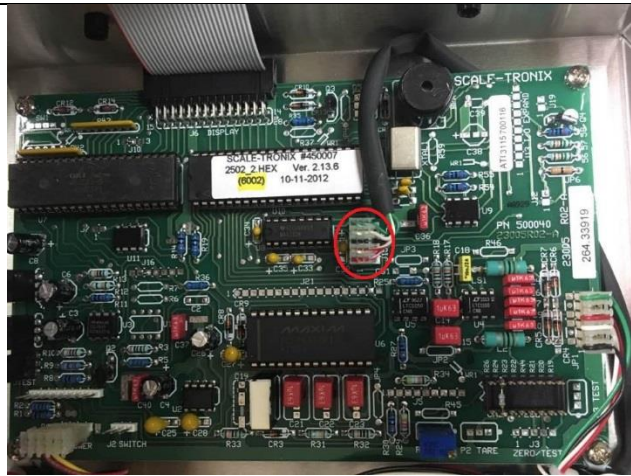

7. Unplug the J4 load cell connector



8. Unplug the J1 power connector

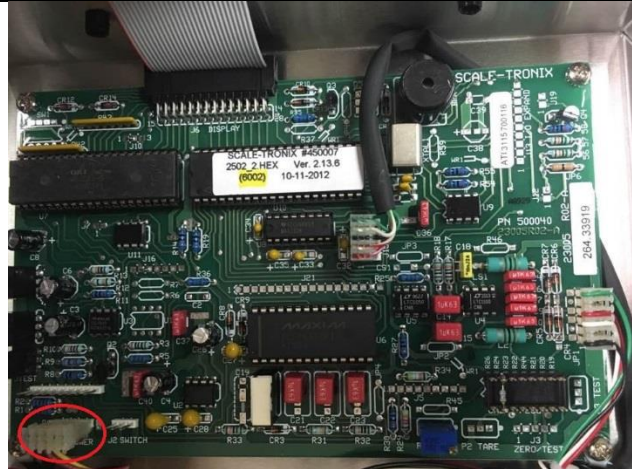



9. Unplug the J6 display connector



10. Using a #1 Phillips screwdriver, remove the screw on each corner and remove the board

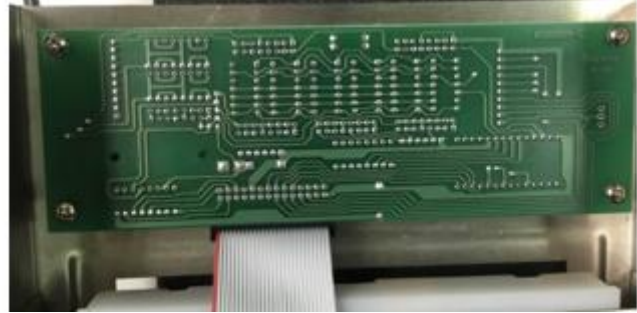

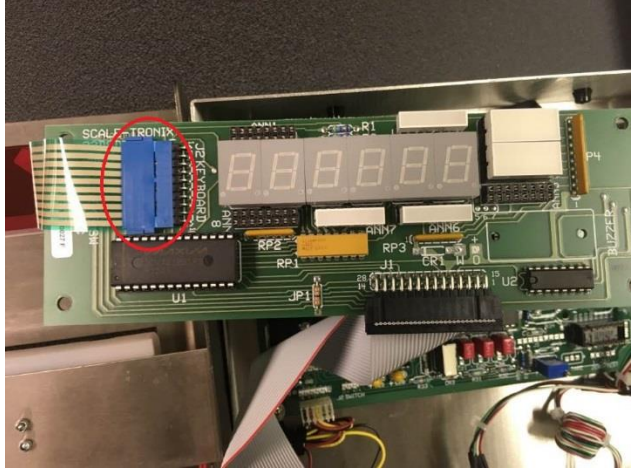
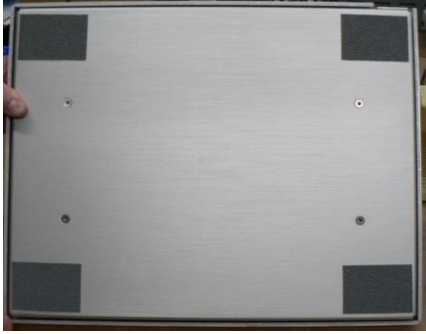
<p>11. Observe the readout circuit board</p>	
<p>12. Using a #1 Phillips screwdriver, remove the screw on each corner of the board</p>	
<p>13. Unplug the blue ribbon cable from the port</p>	
<p>14. Remove the 4 Safety Walk Tape, 2" x 3" in size.</p>	

15. Remove the 4 Jam Nuts (1/4-20; 131052) using a 7/16" deep socket and ratchet socket driver to separate the top and bottom platforms.

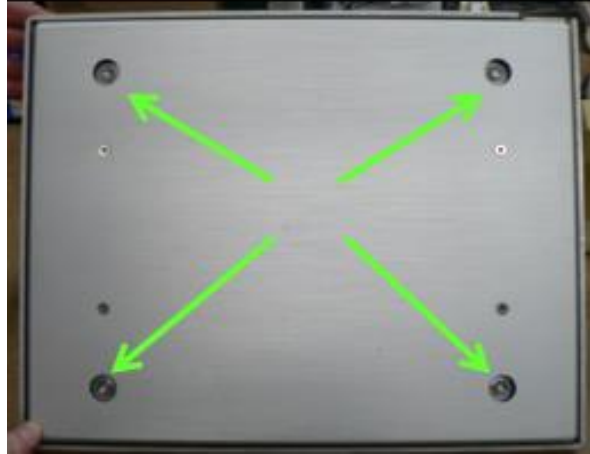

16. Remove slider

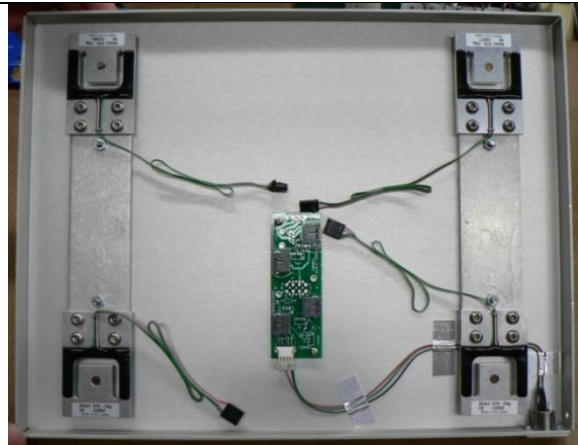

17. Using a 5/32" Allen wrench, remove each load cell's four screws

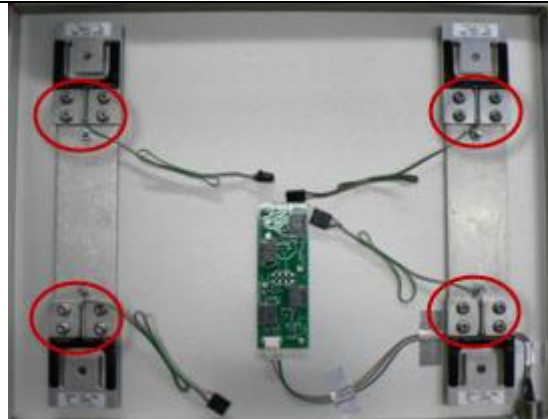

18. Remove the 2 Load Cell Spacers (133089) from Bottom Platform with 4 Screws (10-32 x 3/4 FH; 40523) and 4 Lock Nuts (10-32 KEPS) using a 3/8" deep socket and ratchet socket driver.

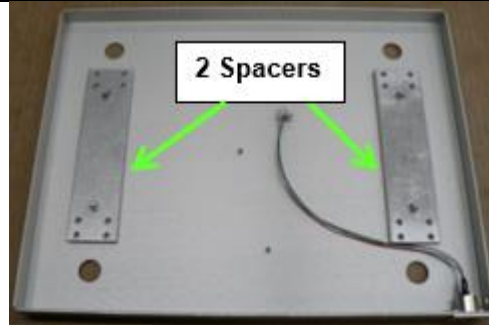

19. On the junction board, unplug the clear connector and remove the black connector by gently pressing the black switch on the connector and pull out

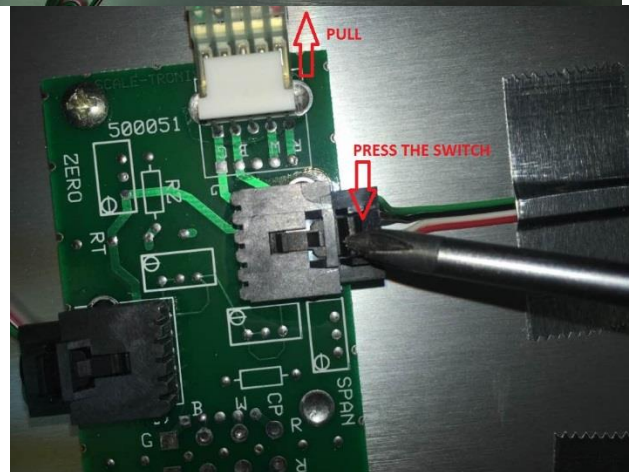
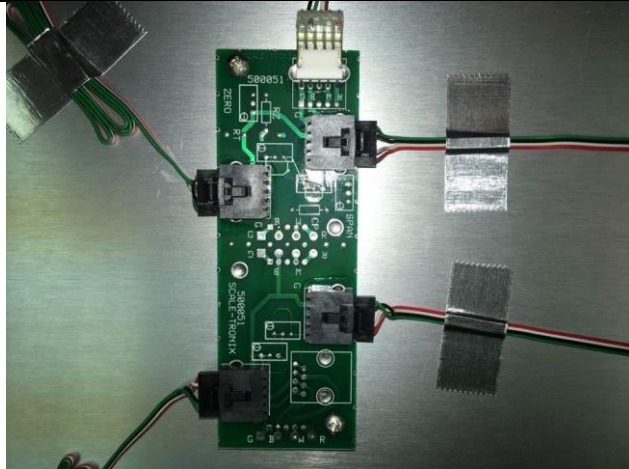

20. Using a #1 Phillips screwdriver, remove the junction board's two screws, remove the junction board

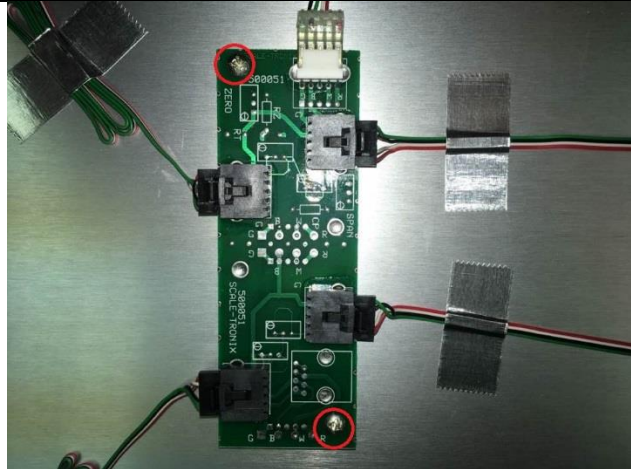

21. Remove 2 Screws (4-40 x 1/2 FH PHIL; 66530) and 2 Lock Nuts (4-40 KEPS) using #1 Phillips screw driver. Position Shell so set screw hole faces access hole.

Note: Set screw has left handed thread.

22. Turn set screw counter clockwise using a 1/8" wide flat tip screw driver so the screw backs out fully into the Shell hole.

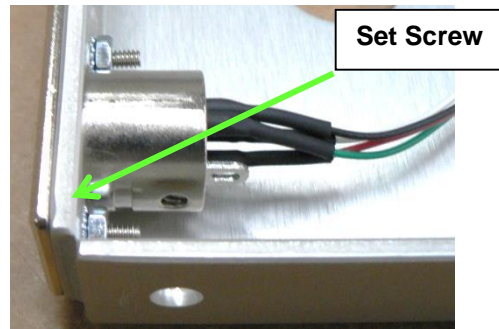
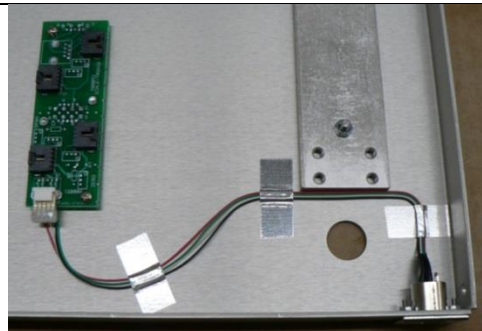

Repair Parts List

5125 & 5127 Repair Parts List

030249W	BOTTOM, 5125 SLIDER SCALE
030251W	DECK, 5125 SLIDER SCALE
030282W	COVER, SLIDER RS-232
030287W	BOTTOM, BARIATRIC SLIDER 5127
030288W	TOP, BARIATRIC SLIDER 5127
039360W	HANDLE 5125/5127
620010	BATTERY DOOR ASSEMBLY 5125
531014	SHUR STEP GRAY - 10" X 14" - 5125
531016	SHUR-STEP GRAY 2" X 3"
133096	Load Mounts 3/8"
255019-KIT	CALIBRATION PLUG, 5102, 5125
705057	ALKALINE "C" CELLS
450006-KIT	FIRMWARE 5002 V2.13.5
630035	BATTERY HOLDER W/EXTERNAL JACK ASSY
700116	PCB INSTRUMENT BOARD (No Cal & firmware Chip)
EM1038	DISPLAY CABLE FOR 22DSDP DISPLAY
700119W	Junction Bd 5202 6202 VG
700064	PCB ASSY DISPLAY 5125/5127
400038	LOAD BEAM 75KG THRU HOLE 11"
710031W	HARNESS, RS-232 DATA
710053W	Harness, Internal Load Cell
710054W	Harness, Relay Switch
134082	Spring Leaf
720024	SWITCH ASSY KG/LB W/RS232
720025	SWITCH ASSY KG ONLY W/RS232
341004	12VDC POWER SUPPLY W/CONNECTOR
531022	SHUR-STEP, 12" X 19" BARI SLIDER 5127
412257	ASSY 700116 MAIN PCBA FOR 5125, STD
412259	ASSY 700116 MAIN PCBA FOR 5125, KG
412368	ASSY 700116 MAIN PCBA FOR 5127, STD
412369	ASSY 700116 MAIN PCBA FOR 5127, KG

5102 Repair Parts List

Component #	Description
750069	A4F to A4F cable assy 6 ft.
730008W	READOUT ASSEMBLY
133086	LOADMOUNT 3/8" X 1" WITH 3/8"
400038	LOAD BEAM 75KG THRU HOLE 11"
531008	SHUR STEP GRAY 12" X 16" 5102
531016	SHUR-STEP GRAY 2" X 3"
700119W	JUNCTION Bd 5202 6202 VG
710047W	HARNESS, INTERIOR PLATFORM L/C
720024	SWITCH ASSY KG/LB W/RS232
720025	SWITCH ASSY KG Only W/RS232
705057	ALKALINE "C" CELLS
450006-KIT	FIRMWARE 5002 V2.13.5
255019-KIT	CALIBRATION PLUG, 5102, 5125
630035	BATTERY HOLDER W/EXTERNAL JACK ASSY
700027W	PCB DISPLAY ASSEMBLY
700116	PCB INSTRUMENT BOARD (No Cal & Firmware Chip)
710018W	HARNESS, LOADCELL (INSIDE R/O)
710031W	HARNESS, RS-232 DATA
EM1037	DISPLAY CABLE/28PIN 15"
341004	12VDC POWER SUPPLY W/CONNECTOR
030127W	BRACKET WALL MOUNT READOUT
41403	COVER, BATTERY
412370	ASSY 700116 MAIN PCBA FOR 5102, STD
412371	ASSY 700116 MAIN PCBA FOR 5102, KG

Schematics

5125/5127 Schematics

DESIGNATOR	QTY	PART No.	DESCRIPTION
A	4	40408	SCW, 10-32 x 3/8" NKL
B	1	530229	LABEL, INSTRUCTION
C	1	530126	LABEL, SCALE CAPACITY 300 kg

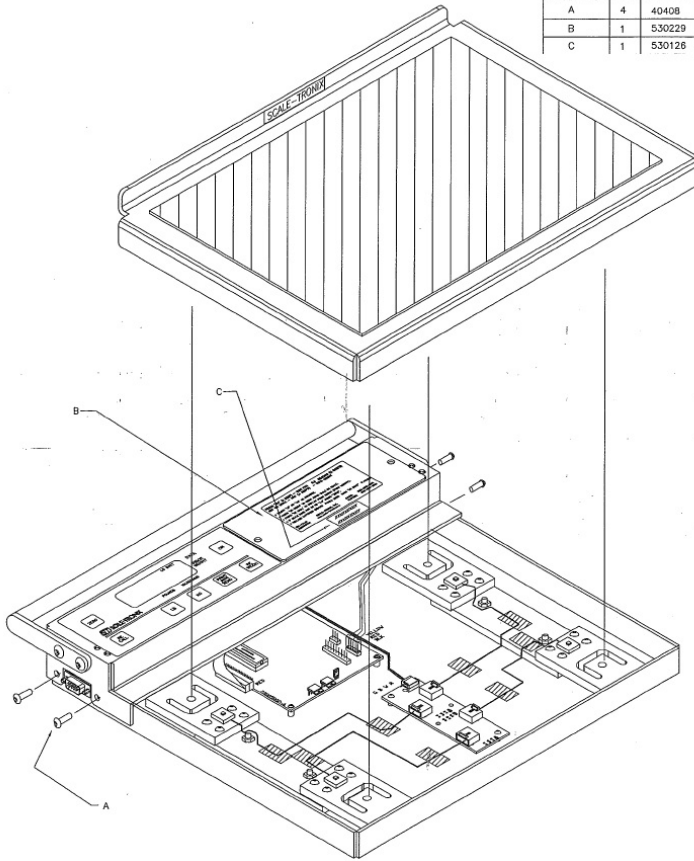

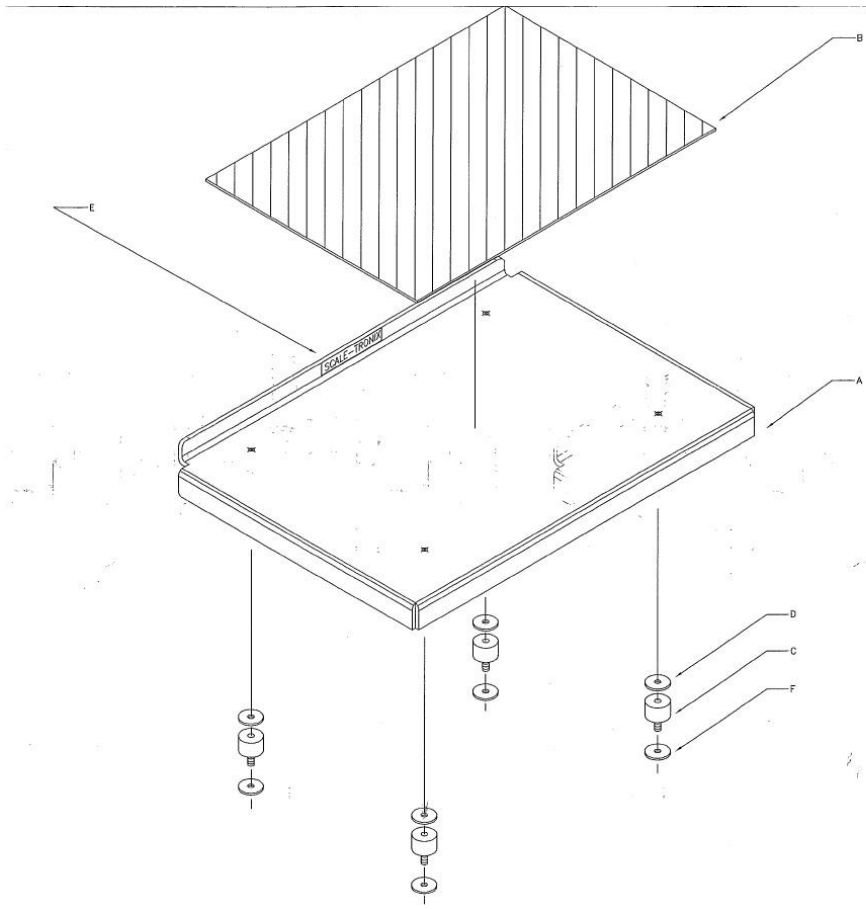

DESIGNATOR	QTY	PART No.	DESCRIPTION
A	1	030251	DECK, 5125 SLIDER SCALE
B	1	531014	SHUR STEP, GRAY 10" x 14"
C	4	133096	LOADMOUNT, 3/8" x 1" WIDTH 3/8"
D	4	50518	WSH. 1/4"ID x 1" x 1/8" THK
E	1	41042	LABEL, S-T
F	4	50530	WSH. 1/4"ID X 1"OD X .050" THK, ZINC, FENDER

DESIGNATOR	QTY	PART No.	DESCRIPTION
A	4	131052	NUT, 1/4-20 JAM
B	4	531016	SHUR STEP, GRAY 2" x 3"
C	1	530237	LABEL, AC POWER JACK 4302/4502/5602/5102/5112
D	2	XXXXXX	LABEL, SERIAL NUMBER...

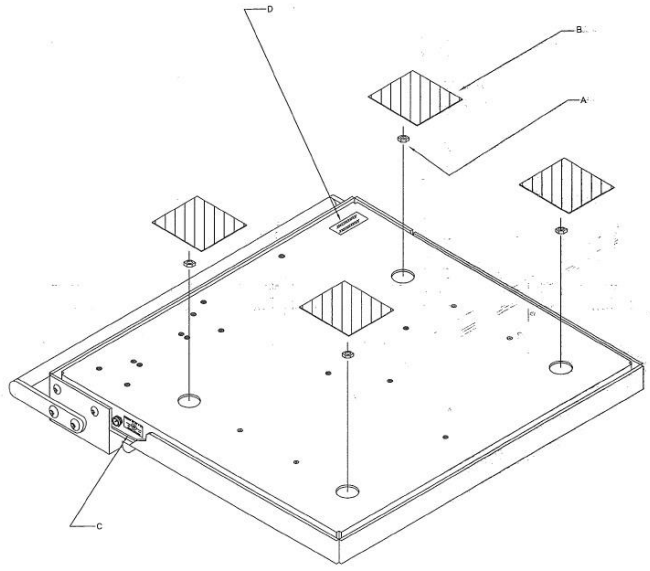

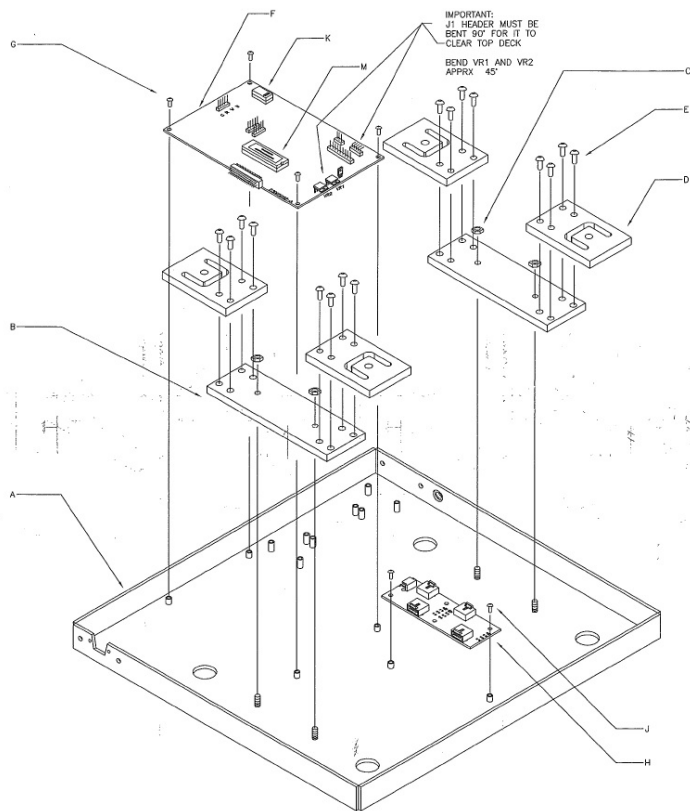

DESIGNATOR	QTY	PART No.	DESCRIPTION
A	1	030249	BOTTOM, 5125 SLIDER SCALE
B	2	133090	SPACER, LOAD CELL 5112 & 52
C	4	24010	NUT, KEPS 10-32
D	4	4000385	LOADCELL 75 KG W/THRU HOLE(5102,22,25,27,5602)
E	16	48112	SCW, 1/4-20 x 1/2" BHMS
F	1	700116	PCB, INSTRUMENT BOARD
G	4	48611	SCW, 6-32 x 1/4" FHMS SEMS
H	1	700119	PCB, JUNCTION 5202, 6202
J	2	48113	SCW, 6-32 x 3/8" PHIL PAN HD
K	1	255019	CALIBRATION, PLUG
M	1	450006	FIRMWARE, 5002

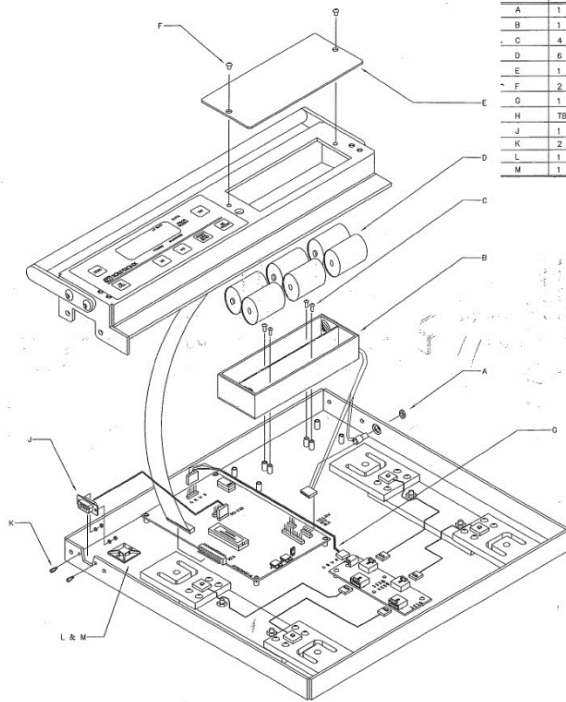

DESIGNATOR	QTY	PART No.	DESCRIPTION
A	1		AC POWER INPUT (SEE BATTERY ASSY 630035)
B	1	630035	BATTERY HOLDER AND EXTERNAL PO
C	4	24014	SCW, 6-32 x 1/4" DRMS
D	6	41005	BATTERY, "C" SIZE ALKALINE
E	1	820010	DOOR, BATTERY ACCESS
F	2	41031	SCW, 10-32 x 1/4" PHMS
G	1	710553	HWRNESS, INTERNAL LOAD CELL
H	TBD	TBD	TAPF, ALUMINUM
J	1	710031	HWRNESS, RS-232 DATA, 5002/6002/6502/6702
K	2	130231	SCW, 4-40 X 1/4" JACK SCW w/HOMARE KEYSTONE #7229
L	1	EM-1029	CABLE TIE DENNISON #05432
M	1	134017	TIE MOUNTS PANDUIT # ABM2S-A-C (was 40474)

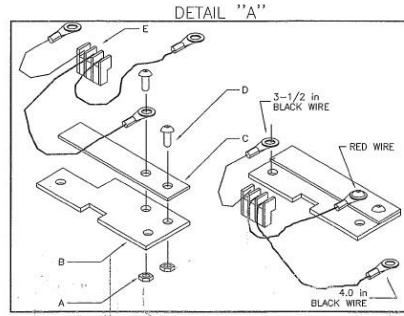
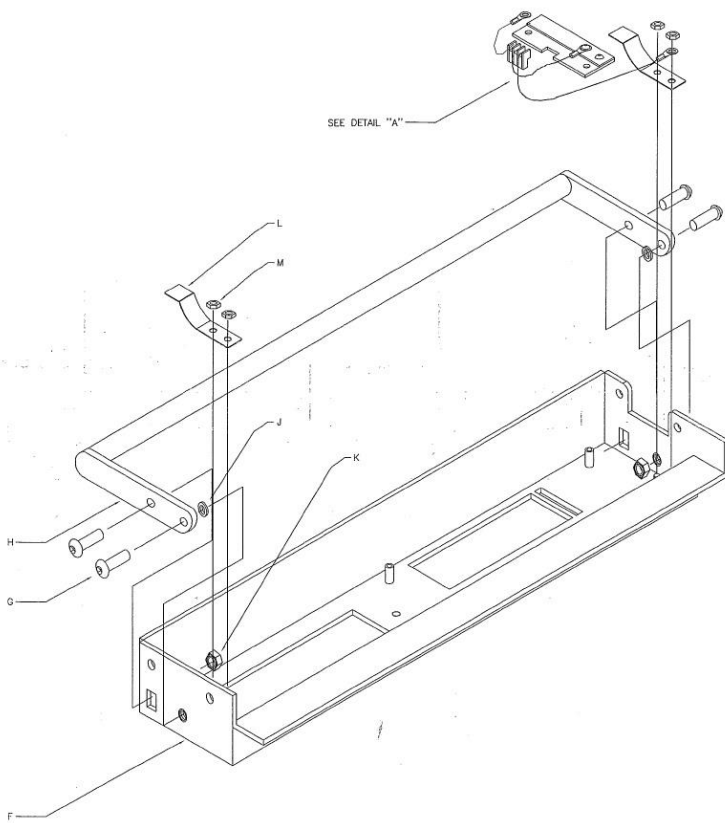

DESIGNATOR	QTY	PART No.	DESCRIPTION
A	2	21287	NUT, 6-32 KEPS
B	1	600027	BRACKET, CONTACT STRIP
C	1	134085	STRIP, CONTACT
D	2	48611	SCW, 6-32 x 1/4" PHMS SEMS
E	1	710064	HARNES, RELAY SWITCH
F	1	030282	COVER, 5125 SLIDER SCALE READOUT (RS-232)
G	4	50529	SCW, 1/4-20 x 3/4" BHSOC.SS
H	1	039360	HANDLE, STAINLESS STEEL
J	2	42114	WASHER, NYLON
K	2	50543	NUT, 1/4-20 JAM ESNA NYLOCK
L	2	134082	SPRING, LEAF
M	4	30349	NUT, 8-32 KEPS

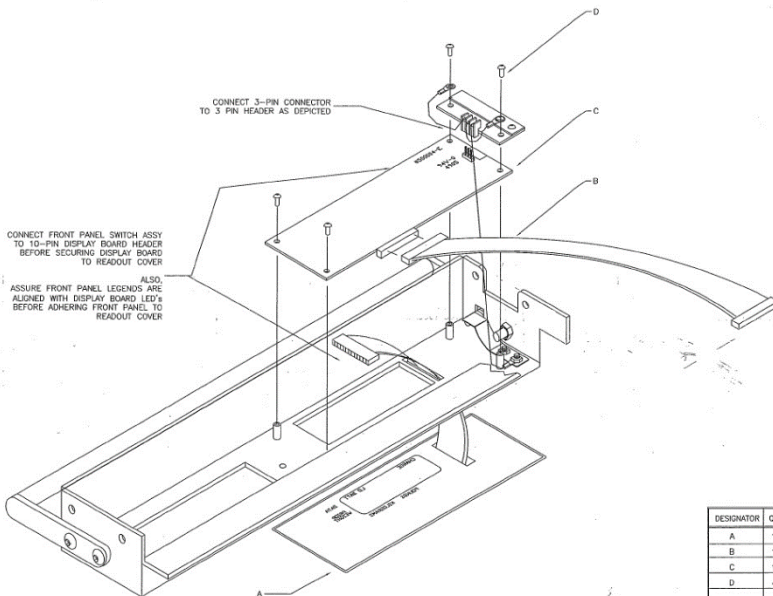

DESIGNATOR	QTY	PART No.	DESCRIPTION
A	1	720024	FACE PLATE AND SWITCH ASSY, RS-232 SCALES
B	1	EM-1038	CABLE, 28-PIN RIBBON 8"
C	1	700064	PCB ASSEMBLY, DISPLAY 5125
D	4	48611	SCW, 6-32 x 1/4" PHMS SEMS

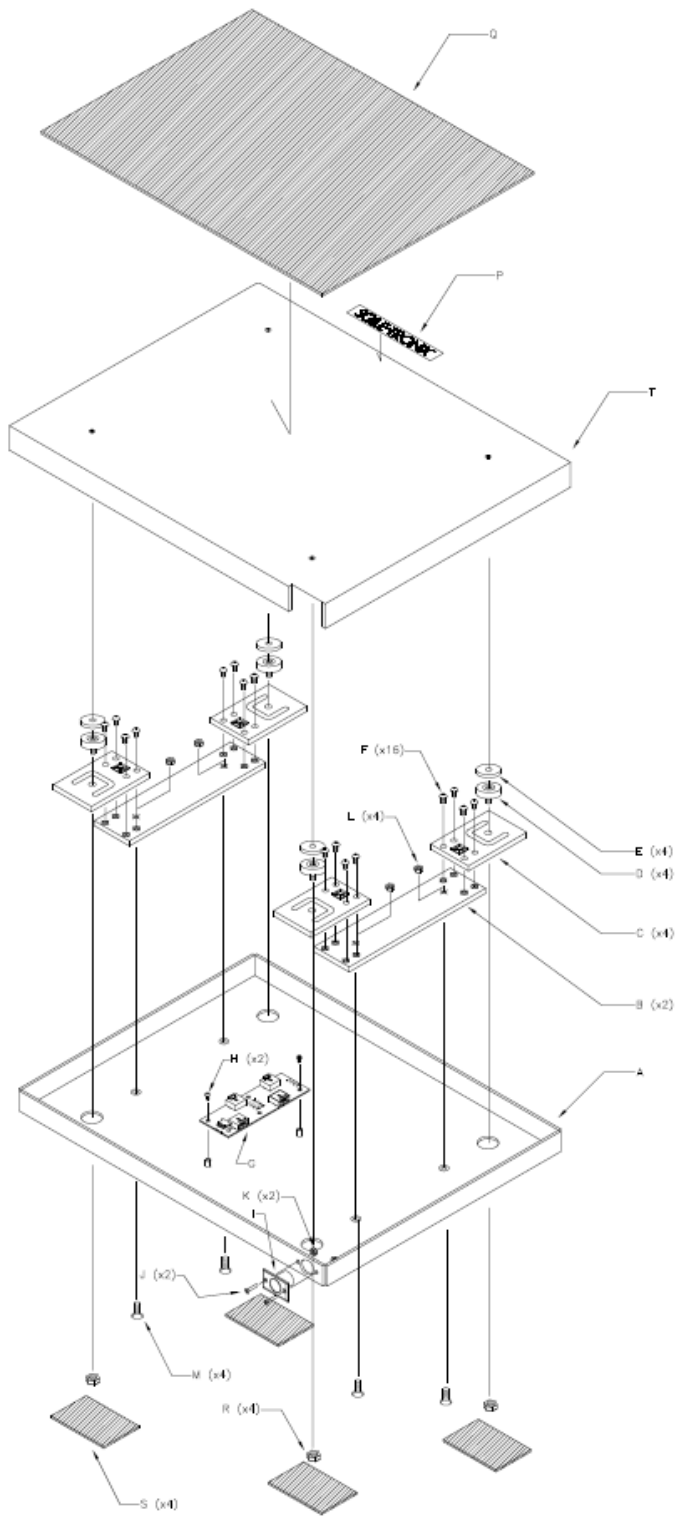

WIRING DRAWING
(TOP VIEW)

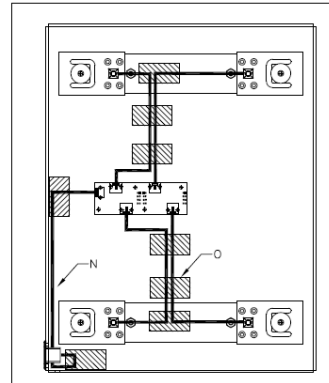

SHUR STEP LOCATION
(BOTTOM VIEW)

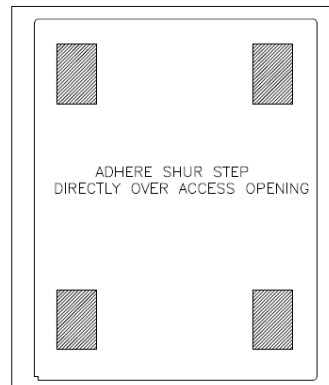

DESIGNATOR	QTY	PART No.	DESCRIPTION
A	1	030120	PLATFORM, BOTTOM 5102
B	2	133089	SPACER, LOADCELL 5102
C	4	400038	LOAD BEAM 75KG THRU HOLE 11"
D	4	133086	LOADMOUNT 3/8" X 1" WITH 3/8"
E	4	50518	WASHER, 0.281" X 1.000" X 0.125"
F	16	48112	SCW, 1/4-20 X 1/2" BHCS, SS, PASSIVATED
G	1	700119W	JUNCTION Bd 5202 6202 VG
H	2	48611	SCW, 6-32 X 1/4" PHMS SEMS, NICKEL
I	1	66430	CONNECTOR SHELL - D4M
J	2	68530	SCW, 4 - 40 X 1/2" FLAT HD PHILLIPS
K	2	106137-1	4-40 KEPS LOCK NUT, ZINC
L	4	106137-4	10-32 KEPS LOCK NUT, ZINC
M	4	40523	SCW, 10-32 X 3/4" FLAT HEAD SOC CAP SCRW
N	1	710047W	HARNES, INTERIOR PLATFORM L/C
O	8	138019	TAPE, ALUMINUM 3/4" X 80YD
P	1	41042	LABEL S-T 4 3/4" X 3/4" BLACK
Q	1	531008	SHUR STEP GRAY 12" X 16" 5102
R	4	131052	NUT, 1/4-20 JAM
S	4	531016	SHUR-STEP GRAY 2" X 3"
T	1	030121W	PLATFORM, TOP 5102

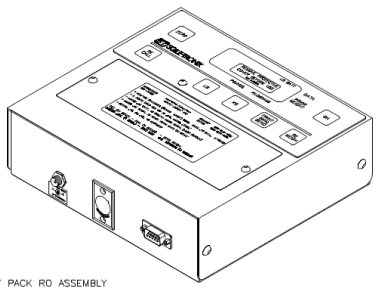
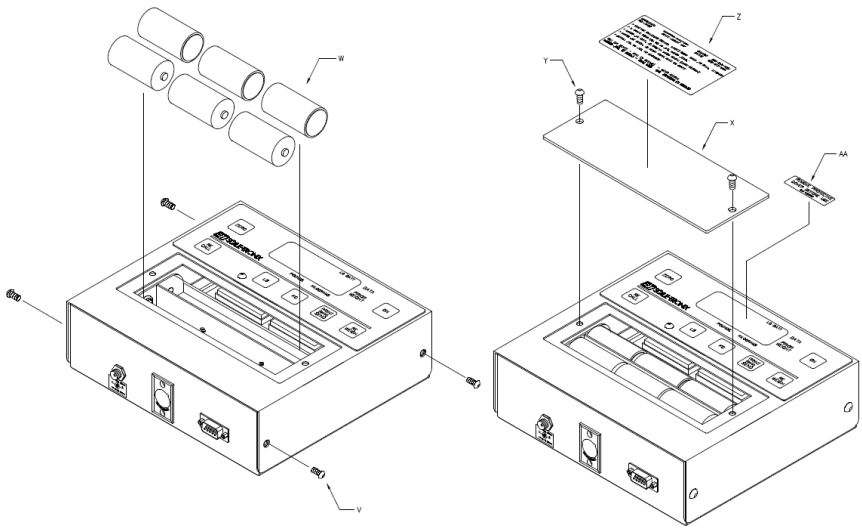

FLAT PACK RO ASSEMBLY

DESIGNATOR	DESCRIPTION: FOR REFERENCE ONLY
V	SCW, 10-32 X 1/4" BUTTON HD SKT NNL
W	BATTERY, 6 C CELL ALKALINE
X	COVER, BATTERY USED ON 4500
Y	SCW, 10-32 X 1/4" PHIL PAN HD NNL
Z	LABEL, NEW FLATPACK READOUT
AA	LABEL, "REMOVE PROTECTIVE COVER BEFORE USE"

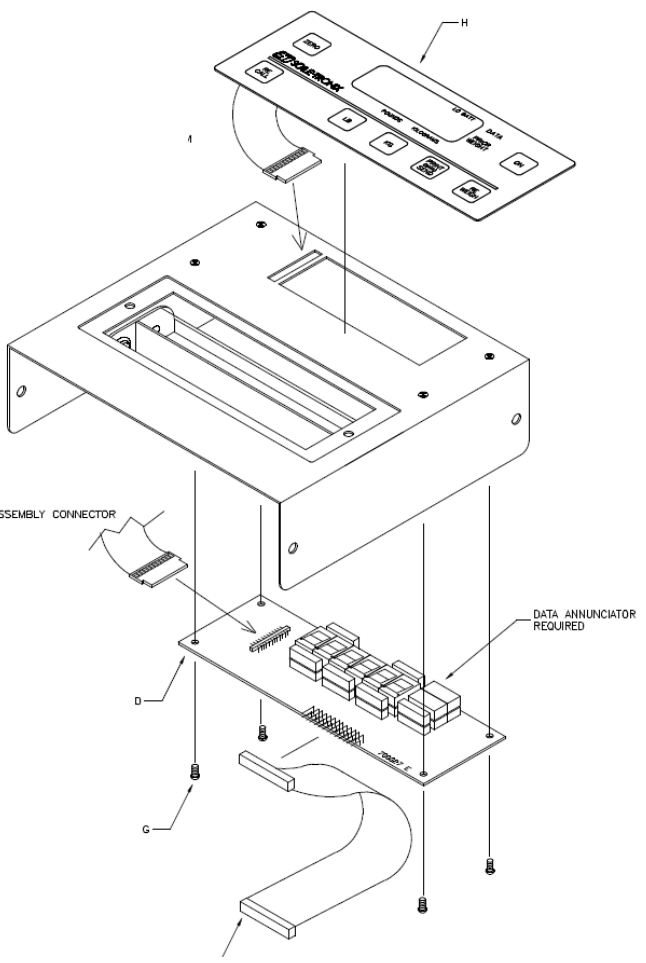
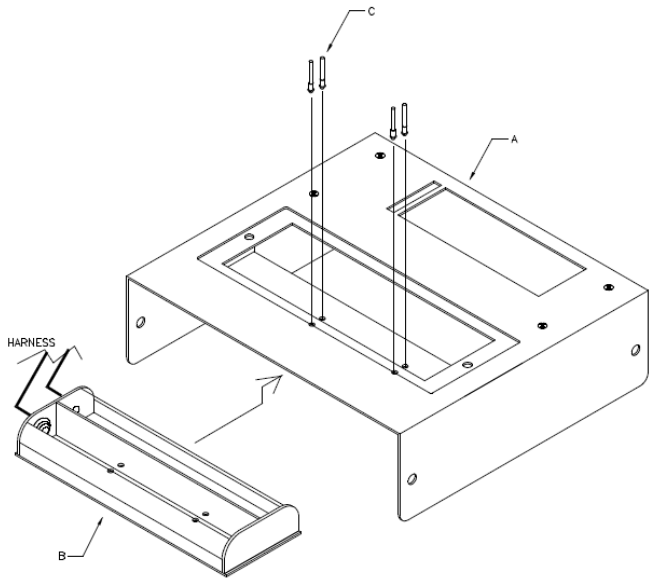

DESIGNATOR	DESCRIPTION: FOR REFERENCE ONLY
A	BOTTOM, 5102/5112/5602 READOUT CABINET
B	BATT & EXT PWR JACK SUB ASSY, 4302/4502
C	RIVET, .328" ALUM POP W/STEEL SHANK
D	PCB ASSY DISPLAY 22DSDP FOR 2002/5002/6002/etc.
E	CABLE, 28 CKT (2x14) RIBBON 15" (4650)
G	SCW, 6-32 X 1/4" PHIL PAN HD EXT SEMS
H	FACE PLATE AND SWITCH ASS'Y, RS-232 GRAY SCALES
	FACE PLATE AND SWITCH ASS'Y, RS-232 (KG ONLY)

TOP VIEW WIRING CONNECTIONS

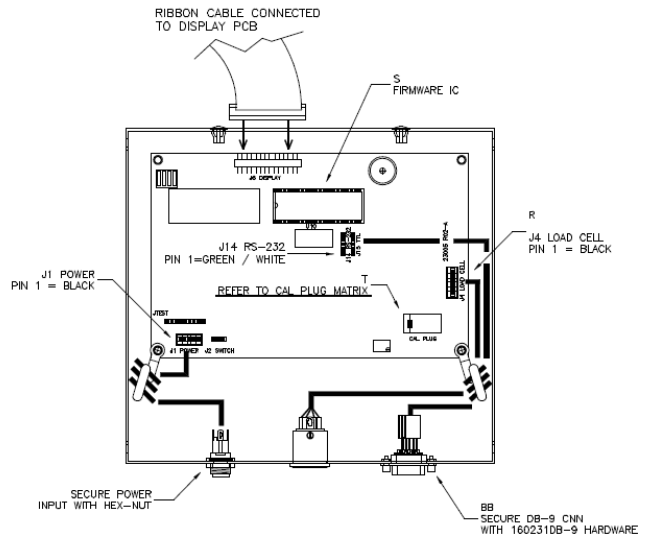
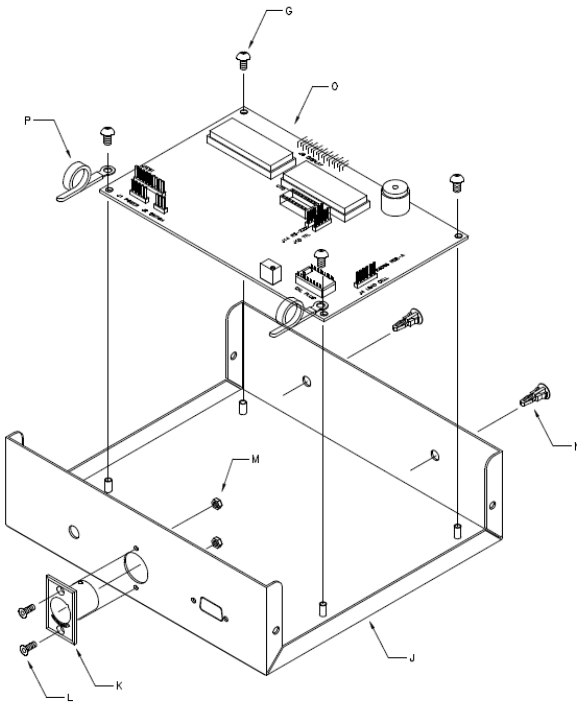

DESIGNATOR	DESCRIPTION: FOR REFERENCE ONLY
J	TOP, 5102/5112/5602 READOUT CABINET
K	CNN SHELL SWITCHCRAFT D4M (USE W/ 20042/110005)
L	SCW, 4-40 X 1/2 FLAT HD MACH NKL
M	NUT, 4-40 KEPS ZINC
N	PLUG, 1/4" PLASTIC HOLE HEYCO # 2603
O	PCB ASSY INSTRUMENT (23005R02A) FOR 5102/5112/5602
G	SCW, 6-32 X 1/4" PHIL PAN HD EXT SEMS
P	CLAMP, METAL WIRE WRAP (RICHCO # VCC-84554)
R	HARNESS, LOAD CELL (INTERNAL, FLATPACK RO)
S	uCOMP (BK) w/5002 FIRMWARE VER v2.xx.5 (see BOM)
T	REFER TO CAL PLUG MATRIX
U	LABEL, AC POWER JACK 4302/4502/5602/5102/5112
BB	HARNESS, RS-232 DATA

