

# THE JOURNAL

From Rockwell Automation and Our PartnerNetwork™

## HALT Cyberthreats

Managing both safety and cybersecurity risks should be an integral part of the IT/OT process in your digital transformation journey.

CYBERSECURITY RISK  
MANAGEMENT: LESSONS  
FROM THE REAL WORLD

HOW DCS MIGRATION  
SAVES WASTEWATER PLANT  
\$34K A YEAR

BEVERAGE GIANT BOOSTS  
THROUGHPUT USING  
BATCH MANAGEMENT

PSRST STD  
US POSTAGE  
PAID  
HARRISBURG PA  
PERMIT # 249

# Universal Industrial Gateway

*Bringing the connected enterprise to all devices.*

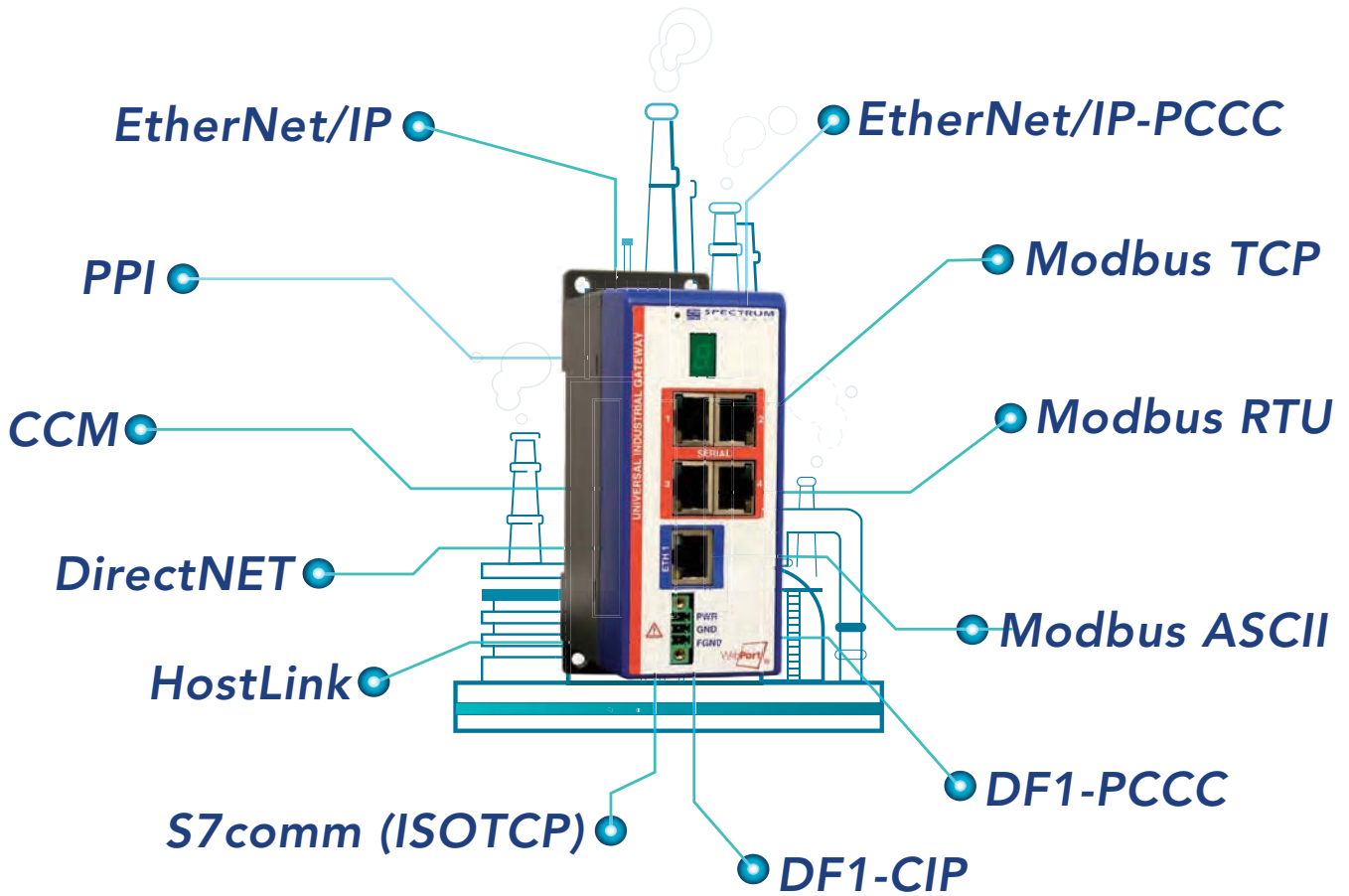

12 Protocols, 5 ports, 1 box  
72 Protocol Combinations  
Browser Based Configuration

No Programming Software  
No I/O Tree Changes  
No Ladder Logic to Program

Request Your Free Demo Unit:

[spectrumcontrols.com/demo](http://spectrumcontrols.com/demo)

+1 425-746-9481

[spectrum@spectrumcontrols.com](mailto:spectrum@spectrumcontrols.com)



Encompass™  
Product Partner

A ROCKWELL AUTOMATION PARTNER  
Global



**SPECTRUM**  
C O N T R O L S



We understand you need insightful process information to help you run your plant efficiently.

# MEASURED VALUE + ADDED VALUE

You make confident decisions backed by process data and a complete portfolio of services and solutions to support you.

## Proline 300/500 - Flow measuring technology for the future



- Added value throughout the entire life cycle of your plant, based on decades of experience in safety-related application
- Entirely developed according to SIL (IEC 61508). Maximized plant safety and availability due to unique features – such as webserver, WLAN, WirelessHART, Industrial Ethernet, or Heartbeat Technology with comprehensive diagnostic and verification functions
- Multifunctional transmitters – combinable with all tried-and-tested Promass and Promag sensors
- Seamless system integration via HART, PROFIBUS PA/DP, FOUNDATION Fieldbus, Modbus RS485, EtherNet/IP and PROFINET



Encompass™  
Product Partner

A ROCKWELL AUTOMATION PARTNER  
(Global)

Do you want to learn more?

[www.us.endress.com/proline-simple-clever](http://www.us.endress.com/proline-simple-clever)

Endress+Hauser 

People for Process Automation



# CONTENTS

December 2020

## HALT Cyberthreats

Managing both safety and cybersecurity risks should be an integral part of the IT/OT process in your digital transformation journey.

16

### FEATURES

#### How DCS Migration Saves Wastewater Plant Over \$34K a Year

Modernizing its legacy system helped the City of Tacoma improve real-time visibility into operations, ease troubleshooting and reduce energy costs.

#### Cybersecurity Risk Management: Lessons Learned from the Real World

High-profile cyberthreat events have involved plant control-room computer systems accidentally infected with a virus or ransomware, so it's vital to update your cybersecurity and know your vendors' security practices.

#### How Virtual Commissioning Can Build Faster, Safer Machines

Learn how an injection molding machine maker eliminated oscillation issues during production and reduced its machine cycle time by more than 25%.

20

#### Case Study: Beverage Giant Increases Throughput by Using Batch Management & Process Controls

The major soft drink producer replaced outdated systems and chose an infrastructure for digital transformation to keep up with syrup demand and allow for future products.

22

#### 3 Keys to Automated Weighing Accuracy

Learn how to automate machines with weight-based control using less hardware while helping users achieve high levels of quality and operator safety.

26

#### How Digital Two-Way Radios Support Smart Manufacturing

We examine how these radios can help minimize downtime and improve efficiency and safety by unifying voice, video, data and analytics.

28

31

33

©The Journal From Rockwell Automation and Our PartnerNetwork™, 2020, Volume 27 Number 6, is published six times a year by PUTMAN MEDIA, INC., 1501 E. Woodfield Rd., Suite 400N, Schaumburg, IL 60173 (Phone 630/467-1300). Address all correspondence to Editorial and Executive Offices, same address. Printed in the United States. ©The Journal From Rockwell Automation and Our PartnerNetwork 2020. All trademarks, company names and product names referred to throughout this publication are used for identification purposes only and are the properties of their respective companies. All rights reserved. The contents of this publication may not be reproduced in whole or part without consent of the copyright owner, including digital reproduction. SUBSCRIPTIONS: Qualified-reader subscriptions are accepted from Operating Management in the industrial automation industry at no charge. To subscribe or unsubscribe, email Carmela Kappel at ckappel@putman.net. Putman Media Inc., which also publishes Chemical Processing, Control, Control Design, Smart Industry, Pharma Manufacturing™, Plant Services, and Food Processing, assumes no responsibility for validity of claims in items reported. Putman Media, Inc. is not affiliated with Rockwell Automation, Inc. "The Journal From Rockwell Automation and Our PartnerNetwork" is a trademark of Rockwell Automation, Inc. and its use in the title and masthead of this publication is by license granted by Rockwell Automation, Inc. to Putman Media Inc. Some photographs and other illustrations printed in this publication may be used with safety equipment removed or altered for illustrative purposes. However, in actual operation, it is recommended that all correct safety procedures and equipment always be utilized.



## THE JOURNAL

From Rockwell Automation and Our PartnerNetwork™

### DEPARTMENTS

Editor's Viewpoint	7
News & Noteworthy	8
Encompass Showcase	35
Product Focus	36
Ad Index	42

### ADDITIONAL RESOURCES

The "Automation Chat" podcast features fun and educational discussions with insights about technologies and trends affecting your rapidly changing manufacturing environment. Hosted by Theresa Houck, Executive Editor of *The Journal From Rockwell Automation and Our PartnerNetwork™* magazine, it's available on your favorite podcast app, on the web at <https://rokthejournal.podbean.com>, or on YouTube at <http://bit.ly/tjplaylists>.

Here are some recent episodes:

#### What is Edge Computing, and Is It for You?

Jason Andersen from Stratus Technologies talks about what edge computing is and how it differs from the cloud. Learn how to know if edge computing will help you; what's involved in implementing it; and get examples of it at work in real companies. And see how OEMs are using edge computing to provide new capabilities for customers. Listen on your podcast app, on the web at <https://bit.ly/tj20stratuspod>, or watch on YouTube at <https://youtu.be/SVEzPU5TVGU>.

#### How Automating Production-Line Labeling Can Help Prevent Bottlenecks & Recalls

In this podcast, Adem Kulazovic, Director of Product Management at Domino Amjet, explains how coding automation eliminates manual product and package labeling to improve productivity, reduce errors and avoid unplanned downtime. See how it's integrated with existing ERP or SCADA systems. Listen on your podcast app or on the web at <https://bit.ly/tj20dominopod>, or watch on YouTube at <https://youtu.be/vlg1YlGbt5M>.

20



26



33



# GL - Servo Wheel Drive

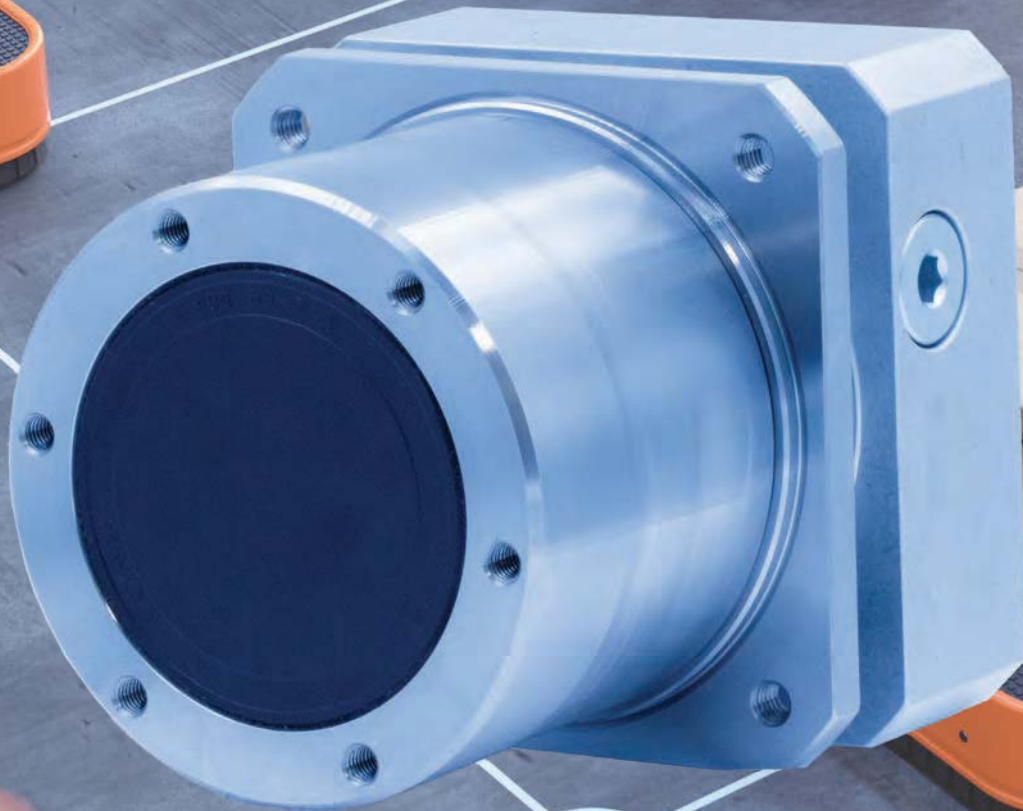

Designed for AGV applications, the GL series gearbox unique rotary housing embeds the in the drive wheel, saving space in the cart interior.

Available now!

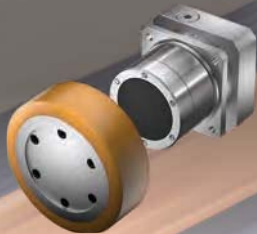

GLS - Input Shaft Option

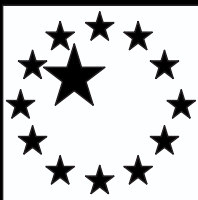

## APEX DYNAMICS

Precision Gear Solutions for Automation

[www.apexdynamicsusa.com](http://www.apexdynamicsusa.com)

631-244-9040



Encompass<sup>™</sup>  
Product Partner

A ROCKWELL AUTOMATION PARTNER  
Global



# THE JOURNAL

From Rockwell Automation and Our PartnerNetwork™

DECEMBER 2020, VOLUME 27, NO. 6

In Memory of Julie Cappelletti-Lange  
Vice President 1984-2012

Putman Media, Inc.  
1501 E. Woodfield Rd., Suite 400N  
Schaumburg, Ill. 60173, 630-467-1300

## Putman Editorial & Sales Team

Publisher:

**Mike Brenner**

mbrenner@putman.net

Executive Editor:

**Theresa Houck**

thouck@putman.net

Managing Editor:

**Amanda Joshi**

ajoshi@putman.net

Advertising Sales Managers:

**Michael Connaughton**

mconnaughton@putman.net

Production Manager:

**Rita Fitzgerald**

rfitzgerald@putman.net

Art Director:

**Michael Annino**

mannino@putman.net

## Putman Media Publishing Team

President and CEO:

**John M. Cappelletti**

Vice President, Content:

**Keith Larson**

Circulation Manager:

**Patricia Donatiu**

Vice President, Creative & Production:

**Stephen C. Herner**

The Journal From Rockwell Automation and Our PartnerNetwork is published six times a year by Putman Media, Inc. "The Journal From Rockwell Automation and Our PartnerNetwork" is a trademark of Rockwell Automation and its use in the title and masthead of this publication is by license granted by Rockwell Automation to Putman Media, Inc.

Other trademarks are property of their respective owners.

To subscribe or unsubscribe, e-mail Carmela Kappel at ckappel@putman.net.

© The Journal From Rockwell Automation and Our PartnerNetwork 2020. All rights reserved.

 PutmanMedia®



## COVID-19 CAN'T STOP OUR PROGRESS



I remember this time last year, looking forward to 2020... insert rolling eyes here. After a year like we've all had, it's hard to know what's going on or what's going to happen next. The last thing we need is more uncertainty. But for our work-related activities, here are some ways to know what's going to happen next, and COVID-19 can't do anything about it.



The 2020 Automation Fair® At Home live event in November is over, but all the content is still available on demand until June 2021. You can view training sessions, industry-focused forums, keynote presentations, and virtual tours and exhibits. Attendance is always free. If you're already registered, just log in again; if you're not registered, sign up and start finding the content you want. Go to [www.automationfair.com](http://www.automationfair.com).

Another way to know what's coming is our 2020 Industrial Automation Trends eBook, which you can download at <http://bit.ly/tj20trends>. You'll learn about 9 key trends motivating manufacturers and producers to use smart manufacturing, virtual workforces and digital tools such as edge computing, network modernization, digital twins, augmented reality, advanced analytics and more.

If you like conversations about what's going on, we're always adding new episodes to our "Automation Chat" podcast from thought leaders talking with me about what's happening in our industry. You can listen and subscribe on your podcast app or on the web at <https://rokthejournal.podbean.com>, or watch our conversations on YouTube at <http://bit.ly/tjplaylists>. These aren't sales pitches. They're fun, short, informative discussions with industrial automation pros about technology advancements, digital transformation and industry trends.

I hope this helps, and I sincerely wish you and your loved ones health and happiness in 2021 and beyond. Until next time...

Theresa Houck, Executive Editor





# ROCKWELL AUTOMATION, MICROSOFT EXPAND PARTNERSHIP

The two firms aim to simplify industrial digital transformation initiatives, from the cloud to the edge.

➤➤ Rockwell Automation, Inc. and Microsoft Corp. announced a five-year partnership expansion to develop integrated, market-ready solutions that help industrial customers improve digital agility through cloud technology. By combining each company's expertise in the industrial and IT markets, respectively, teams can work together more seamlessly, enabling industrial organizations to save on infrastructure costs, increase time-to-value, and increase productivity.

Microsoft and Rockwell are working to deliver edge-to-cloud-based solutions that connect information between development, operations and maintenance teams through a singular, trusted data environment. This will allow development teams to digitally prototype, configure and collaborate without investing in costly physical equipment.

This unified information environment also enables IT and OT teams to not only securely access and share data models across the organization, but with their ecosystem of partners as well.

To date, the companies have co-developed more than 20 use cases across food and beverage, household and personal care and life sciences in-



dustries. The solutions developed from this partnership will enhance current offerings from Rockwell Automation.

"This partnership provides Rockwell Automation and Microsoft customers with a holistic, simple solution for IIoT development and operations and removes data silos that hinder industrial digital transformation initiatives," said Blake Moret, Chairman and CEO of Rockwell Automation.

"By eliminating a core barrier to automation initiatives, industrial or-

ganizations establish a digital thread connecting the entire enterprise, which in turn accelerates innovation, maximizes productivity and optimizes operations."

Organizations can access Rockwell Automation solutions now via the Microsoft Azure Marketplace, with more solutions currently in development. The next phase of co-innovation solutions will be available to joint customers of Rockwell Automation and Microsoft customers in early 2021.

## ROCKWELL AUTOMATION ANNOUNCES LEADERSHIP CHANGES

Rockwell Automation, Inc. has announced several changes to its leadership. Most recently, Steve Etzel, currently vice president, finance, assumed an interim CFO role upon the departure of chief finance officer, Patrick Goris. Goris left the company to accept a CFO role at Carrier Global Corp after 14 years with Rockwell Automation.

Etzel has worked at Rockwell Automation for more than 30 years in various finance roles, including vice president, risk management and financial planning, and vice president, treasurer and investor relations. The company has initiated a search process considering internal and external candidates to identify a permanent CFO.

Rebecca (Becky) House has taken on the expanded leadership role of senior vice president and chief administrative and legal officer.



In this newly created role, House is responsible for accelerating the evolution of the company's culture and leading the human resources and talent teams. House also will continue her existing responsibilities overseeing the company's legal, ethics and compliance, global security, public affairs, and environmental, health and safety teams. She reports directly to Blake Moret, Rockwell Automation Chairman and CEO, and leads a team of more than 500.

House graduated from the University of Wisconsin – Madison. She earned her law degree, magna cum laude, from Harvard Law School. She serves on the board of directors for FMI Funds, Inc., MIND Research Institute, and Wisconsin Alumni Research Foundation (WARF). She is also a director of Sojourner Foundation, provider of domestic violence services in Wisconsin.

Rockwell Automation named Isaac Woods vice president, treasurer and board-elected officer of the company. Woods, who most recently served as director, Finance for the company's Power Control business, will report directly to the new CFO. He succeeds Steve Etzel, who will be retiring after more than 31 years with the company.

### >> PartnerNetwork Brief

#### **Schenck Process Group to Acquire Baker Perkins.**

Encompass™ Product Partner Schenck Process Group will acquire the supplier of food processing equipment and aftermarket services for the bakery, confectionery, biscuit, cookie and cracker, breakfast cereal and pet food end-markets. Headquartered in Peterborough, United Kingdom, Baker Perkins serves a diverse and growing mix of customers across the food industry globally.

Since joining Rockwell Automation in 2014, Woods, 35, has served in successive leadership roles spanning corporate finance, treasury, investor relations and business unit finance. As treasurer, Woods will lead all global treasury activities for the company, including bank and capital markets financing, cash management, foreign exchange, insurance and risk management, and pension fund management.



Earlier in his career, Woods held various roles in treasury and financial planning and analysis at SC Johnson and retirement sales services at Edward Jones Investments. Woods holds a bachelor's degree in business administration from Southern Arkansas University and an MBA from Washington University in St. Louis. He is also a Certified Public Accountant.

## ZEBRA TECHNOLOGIES RECEIVES ACCOLADE

Encompass™ Product Partner Zebra Technologies Corp. has been selected as one of Fast Company's 2020 Best Workplaces for Innovators. The company ranked #26 among the top 100 workplaces for empowering employees to innovate.

In addition to company-wide support and funding for innovation, Zebra invests more than 10% of its \$4.5 billion annual revenue in research and development to continue advancing technical innovation and customer value.

Developed in collaboration with Accenture, the 2020 Best Workplaces for Innovators ranks 100 winners from a variety of industries, including computer science, biotech,

consumer packaged goods, nonprofit, education, financial services, cybersecurity and engineering.

Working together, Fast Company editors and Accenture researchers scored nearly 900 applications, and a panel of eight eminent judges reviewed and endorsed the top 100 companies — an increase from last year’s list of 50. The 2020 awards feature workplaces from around the world with several of the honorees based outside the U.S.

The full list of 2020 Best Workplaces for Innovators is available at <https://bit.ly/3d7tdnG>.

## ROCKWELL AUTOMATION ACQUIRES CYBERSECURITY COMPANY

Rockwell Automation, Inc. has acquired Oylo, a privately-held industrial cybersecurity services provider based in Barcelona, Spain. Oylo provides industrial control system (ICS) cybersecurity services and solutions including assessments, turnkey implementations, managed services and incident response.

Oylo’s experience in OT cybersecurity complements the IT cybersecurity knowledge gained through the recent acquisition of Avnet Data Security by Rockwell Automation. With the addition of Oylo, Rockwell Automation aims to accelerate its global delivery capability in this rapidly developing market and expand the offering of cybersecurity services available to the industrial market.

Oylo will be reported as part of the Lifecycle Services operating segment.

### >> PartnerNetwork Brief

**HMS Networks Becomes IEC 62443-4-1-Certified.** As of October 2020, Encompass™ Product Partner HMS Networks is certified according to the IEC62443-4-1:2018 standard. TÜV Rheinland performed the certification process to validate a secure product development life cycle process within industrial automation and control systems. IEC62443-4-1 is part of the IEC 62443-4:2018(E) standard which specifies the process requirements for secure development of products used in industrial automation and control systems.



### >> PartnerNetwork Brief

**FANUC Named Top Workplace In 2020.** Encompass™ Product Partner FANUC, based in Rochester Hills, Michigan, was named a top work place in Michigan by the Detroit Free Press for the ninth consecutive year. FANUC ranks 15 out of 30 companies in the large employer category in Michigan. In addition, the Chicago Tribune named FANUC’s Hoffman Estates, Illinois regional office a top workplace in Illinois for the third year in a row.

## U.S. DOL FETES FANUC

Rockwell Automation Encompass™ Product Partner FANUC has been named a Standards Recognition Entity (SRE) by the U.S. Department of Labor (DOL) for its focus on robotics and advanced automation. It specifically recognizes the integration of these technologies into systems and the future workforce needed to support them. FANUC shares this achievement in collaboration with industry partners including Rockwell Automation, APT Manufacturing Solutions and the National Occupational Competency Testing Institute (NOCTI).

In May 2020, the U.S. DOL established a system for developing high-quality industry-recognized apprenticeship programs (IRAPs). IRAPs provide individuals with opportunities to obtain workplace-relevant knowledge and progressively advancing skills. IRAPs include a paid work and educational component and result in industry-recognized certifications.

The intent is to address America’s skills gap and rapidly increase the availability of high-quality apprenticeship programs in sectors where such opportunities are not widespread. SREs have the authority to oversee the development of high-quality IRAPs.

FANUC and Rockwell have worked together over the past decade developing training, certifications and an education and training delivery network. This network of educational partners includes more than 1,200 high school and post-secondary FANUC-certified training organizations, and over 150 university and career technical training partners associated with this industry team.

As an SRE, FANUC and its coalition will work to align customers with schools in FANUC’s education network local to their manufacturing facilities. The team will guide each company to develop an IRAP that helps them build a pipeline of skilled workers by upscaling current employees and filling open positions with high school and college students.





# I AM THE NEW GENERATION

## R SERIES V POSITION SENSORS FOR INDUSTRIAL APPLICATIONS

- Rugged & reliable
- Better performance
- Backward compatible



IRAPs incorporate industry training and certifications that expand into relevant apprenticeships to develop the next-generation advanced manufacturing workforce. As a DOL-designated SRE, the FANUC-Rockwell Automation coalition will assure IRAPs are high quality, competency-based, modular, scalable and portable to secure the workforce for U.S. manufacturing.

In addition to its IRAP, the FANUC-Rockwell SRE team has worked closely to promote exciting careers in robotics and automation as well-paying jobs with opportunities for growth. Find out more at [fanucamerica.com/education](http://fanucamerica.com/education).

## ODVA UPDATES CIP SECURITY

ODVA has announced that user-level authentication has been added to CIP Security™, the cybersecurity network extension for EtherNet/IP™. Previous publications for CIP Security specifications included key security properties such as a broad trust domain across a group of devices, data confidentiality, device authentication, device identity and device integrity. CIP Security now adds a narrow trust domain by user and role, an improved device identity including the user, and user authentication.

The CIP Security User Authentication Profile will provide user-level authentication with a fixed user access policy based on well-defined roles and basic authorization via both local and central user authentication. CIP Security's ability to authenticate via the device or through a central server allows for simplicity in smaller, simple systems and efficiency in large, complicated installations.

The new User Authentication Profile makes use of several open, common, ubiquitous technologies, including OAuth 2.0 and OpenID Connect for cryptographically protected token-based user authentication, JSON Web Tokens (JWT) as proof of authentication, usernames and passwords, and already existing X.509 certificates to provide cryptographically secure identities to users and devices.

It uses a cryptographically secure user authentication session ID, generated by the target on presentation of a valid JWT by the user, to map between an authentication event and the messages sent by a user for CIP communications. The user authentication session ID is transmitted over EtherNet/IP using (D)TLS and a confidentiality-enabled cipher suite per CIP Security's EtherNet/IP confidentiality profile.

Visit [odva.org](http://odva.org) to obtain the latest version of The EtherNet/IP specification including CIP Security.

### >> PartnerNetwork Brief

**Endress+Hauser Expands Service and Support.** Rockwell Automation Strategic Alliance Partner Endress+Hauser has improved its My Tech Support Portal. In addition to phone support, the portal offers 24/7 access to a growing online knowledge base on Endress+Hauser instrumentation and applications, along with the ability to create and manage support and service cases online. Users can log in, describe the issue, and access the knowledge database for an immediate solution. Users also can open new support cases directly in the portal and monitor the status and history, including working with technical support experts. For more information, visit [https://eh.digital/my\\_tech\\_support\\_us](https://eh.digital/my_tech_support_us).





# MicroLogix 1400 controller, **still active** as ever.



Our commitment to you for SCADA applications remains strong, just like our continuous investment in MicroLogix™ 1400 control systems. With protocol support for DF1, DH-485, Modbus RTU, DNP3 and ASCII, we can help you ease your effort to monitor and control water quality and comply with existing regulations for wastewater treatment systems. This solution is just one of the many possibilities.

With an installed base of **over 2 million MicroLogix™ controllers**, you have every reason to be a proud customer of ours and continue your journey with us.

Still active [rok.auto/micrologix1400](http://rok.auto/micrologix1400)

Copyright © 2020 Rockwell Automation, Inc. All Rights Reserved.



**Allen-Bradley**

by ROCKWELL AUTOMATION



## PTC AND ROCKWELL AUTOMATION EXTEND STRATEGIC ALLIANCE

Rockwell Automation and PTC are expanding their strategic alliance to extend both companies' sales and product development efforts and expand the agreement to include PTC's product life cycle management and software as a service (SaaS) products. This will streamline efforts to provide a comprehensive digital thread solution, from upfront design through the operate, maintain and optimize life cycle stages.

PTC will also offer the Rockwell Automation virtual machinery simulation and testing software to its own customer and partner network. Under the agreement, both organizations will continue to leverage each other's resources, technologies, industry knowledge, and market presence to seamlessly serve their customers through 2023 and beyond.

The companies' primary joint offering, FactoryTalk<sup>®</sup> InnovationSuite, powered by PTC, is a digital transformation software suite that offers fully integrated Industrial Internet of Things (IIoT), edge-to-cloud analytics, manufacturing execution systems (MESs), and augmented reality (AR). The software is designed to help rapidly develop and operationalize, and globally scale innovative solutions.

## GIPSON JOINS BOARD OF DIRECTORS

Rockwell Automation, Inc. announced that William P. Gipson was elected to its board of directors effective November 4, 2020. Gipson spent his career at The Procter & Gamble Company, retiring in 2019 after more than 34 years during which he held senior executive roles overseeing R&D, innovation, and diversity and inclusion.

During his years at P&G, a leading consumer packaged goods company, Gipson led research and development for a broad range of products and markets. He served in business unit and enterprise-level roles, leading global teams and living and working on three continents.

In Gipson's final role as president, Enterprise Packaging Transformation, he led end-to-end value creation across all P&G businesses, functions, and regions, including packaging-related supply chain transformation and digital and bricks-and-mortar channel readiness. While serving



as chief diversity officer for eight years concurrently with his other roles, Gipson was a key member of the executive team that embedded citizenship strategies into P&G's global operating model.

Gipson serves on the boards of the Executive Leadership Council and

the STEM Pathway to MBA at the University of Alabama. He holds a Bachelor of Science in chemical engineering from the University of Alabama and is a proud U.S. Air Force veteran.

## ROCKWELL AUTOMATION TO ACQUIRE FIIX INC.

Rockwell Automation, Inc., plans to acquire Fiix Inc., a privately-held, AI-enabled computerized maintenance management system (CMMS) company. Fiix, founded in 2008, is headquartered in Toronto, Ontario, Canada.

Fiix's cloud-native CMMS creates workflows for the scheduling, organizing, and tracking of equipment maintenance. It connects seamlessly to business systems and drives data-driven decisions. The company's revenue grew 70% in 2019 with more than 85% recurring revenue. Fiix has more than 2 million assets under management and creates more than 6 million work orders a year.

Fiix will report as part of the Rockwell Automation Software & Control operating segment. The transaction is expected to close by the end of the 2020 calendar year, subject to customary approvals and conditions.

## NYMI JOINS PARTNER NETWORK

Nymi Inc., based in Toronto, has joined the Rockwell Automation PartnerNetwork<sup>™</sup> program as an Encompass<sup>™</sup> Partner. The company supports digital transformation efforts while protecting the health, safety, and security of connected workers. Its workplace wearable, the Nymi Band, provides organizations with a platform to achieve zero-trust security principles and biometrics authorization while solving a variety of challenges that impact productivity, compliance, health/safety and culture.



ENJOY *THE JOURNAL'S* PODCAST,  
“AUTOMATION CHAT”

Join Theresa Houck, Executive Editor of *The Journal From Rockwell Automation and Our PartnerNetwork* magazine, for our “Automation Chat” podcast.

Enjoy short, informative and fun conversations with industrial automation pros about technology, digital transformation, industry trends, workforce challenges and more.

Available on your favorite podcast app, or listen here:

<https://rokthejournal.podbean.com>

LISTEN NOW!



# HALT Cyberthreats

Managing both safety and cybersecurity risks should be an integral part of the IT/OT process in your digital transformation journey.





In modern industrial environments, safety is an expectation. In most places, the safety of workers and the environment is expected by law, by contract and by culture. And the care and safety of physical production assets is critical to profitability.

Failure to manage cybersecurity risks puts more than your customer records at risk — it places your physical assets and intellectual property at risk, along with the safety of workers, the environment, and the surrounding community.

Best-in-class companies already are proving the tremendous value of digital transformation. Using greater connectivity, smart devices, systems, and software, they're gaining contextualized information and insights into their operations. These insights are helping increase throughput and efficiency, decrease costs, make smart and timely decisions, improve safety and meet customer expectations.

The necessity of these insights is driving investments in:

- Smarter devices that detect when they need maintenance before they fail.
- Integrated control systems that analyze the current state of operation and optimize productivity and safety.
- Connectivity throughout the supply chain to coordinate activities.

## >> Rockwell Automation Encompass Partners Support Cybersecurity

Encompass™ Product Partner companies in the Rockwell Automation PartnerNetwork™ program provide capabilities that support your cybersecurity efforts. Visit <http://rok.auto/encompass> to learn more about how these network security companies can help you.

- Claroty
- Nymi
- Owl Cyber Defense

However, with smarter technologies and greater connectivity come new risks.

Historically, industrial control systems (ICS) were disconnected from IT used in front offices. ICS ran on proprietary hardware and were even programmed using proprietary systems. Demands for less expensive and easier-to-use ICS products brought the use of open technologies to ICS, and digital transformation brought connectivity of ICS to IT, providing pathways between the Internet and plant floor devices.

Some have used this as an argument against modernization. But, maintaining legacy systems too long can deprive you of the valuable insights the Industrial Internet of Things (IIoT) brings.

In addition, legacy systems most often lack the security measures of contemporary systems — which brings us back to the point. A cyberattack on your ICS can disrupt or damage physical assets, steal intellectual property, alter recipes, injure workers, or cause severe environmental damage to the surrounding area.

## Safety and Security Intertwined

If you're on a digital transformation journey — and most are, whether it's a managed process or slow evolution — managing the inherent safety and security risks should be an integral part of the process. A properly designed security approach will improve information collection, analysis and delivery. It will minimize security-related interruptions and frustrations. And it will help protect your enterprise.

Security, like safety, approaches issues based on handling risk, leveraging continuous assessment and baselining to confirm you're managing to a risk threshold. Your level of acceptable risk will vary by industry and potential outcomes.

Today, both security and safety standards are recognizing these risks:

## >> The Case for Cybersecurity Amid COVID-19

The current global pandemic highlights the importance in driving home the need for strong cybersecurity practices. In trying times, business rules can relax, but cybersecurity cannot. This is especially true as we work our way through the pandemic by using technology to help reduce the risk of exposure for millions of people by providing flexibility in traditional work rules.

Many industrial companies might have limited or suspended their operations during the COVID-19 pandemic, but still have many workers doing their jobs from home. Then there are companies that have been deemed essential because they provide critical supplies such as food and medicine, and critical infrastructure services. These companies also have a large number of remote workers that are essential to keeping operations running in these extraordinary times.

Whatever the state of your operations, your remote workforce is creating a larger attack surface for cybercriminals that must be addressed as part of your cybersecurity strategy.

### The New Normal

As many states began to lockdown to prevent the spread, Gartner reported in a March 17, 2020 survey of 800 HR executives that 88% of organizations have encouraged or required employees to work from home. FreeConferenceCall, a telecom service, said its usage is up 2,000% in the U.S. and 4,322% in Italy. And the remote-conferencing provider Zoom has seen use of its services skyrocket to 200 million daily users from 10 million in December.

People are using remote tools in unanticipated ways for both work and socializing, presenting unexpected challenges. Zoom's recent growth has put it in the spotlight over its privacy and security issues. To its credit, Zoom has committed to fixing these issues before adding functionality, and the company is planning a

comprehensive review using third parties to ensure that it's handling security properly.

Meanwhile, the pandemic has unleashed an unprecedented number of online scams. Cybercriminals are preying on broad swaths of the population that are working remotely, seeking medical information, shopping and socializing online.

Scammers have long piggybacked off major news events to trick people into clicking on phishing links and downloading malicious software. And sadly, the coronavirus is proving to be just another opportunity for them to profit. Case in point: The number of emails

using phony information about the virus to trick people into infecting their phones and computers increased by 14,000% in just two weeks, according to a report from IBM's X-Force research division.

### Is Your Remote Workforce Secure?

As your business operations bend or flex to get through this pandemic, your security must remain rigid.

Refocusing your cybersecurity approach to address the new and increased vulnerabilities introduced by an expanded remote workforce

is important. It's imperative that security fundamentals are in place. Protect devices with an antivirus solution. Update programs and operating systems to make sure vulnerabilities are patched. Train remote workers to recognize phishing e-mails and the risks of downloading.

Individuals should secure home routers and Wi-Fi networks with passwords, and use corporate services for e-mail and other work. Remote workers should verify that conference platform default values are changed to safeguard privacy.

This isn't a time to panic. But it is a time to make sure that basic security protocols are being followed and be vigilant about cybersecurity. □



## Cybersecurity risks are safety risks.

- *Cybersecurity standard ISA/IEC 62443-1-1, Section 4.1: ... However, because industrial automation and control systems equipment connect directly to a process, loss of trade secrets and interruption in the flow of information are not the only direct consequences of a security breach. The potential loss of life or production, environmental damage, regulatory violation, and compromise to operational safety are far more serious consequences. These may have ramifications beyond the targeted organization; they may grievously damage the infrastructure of the host region or nation.*
- *Functional safety standard IEC 61508-1 7.4.2.3: The hazards, hazardous events and hazardous situations of the EUC and the EUC control system shall be determined under all reasonably foreseeable circumstances (including fault conditions, reasonably foreseeable misuse and malevolent or unauthorized action). This shall include all relevant human factor issues, and shall give particular attention to abnormal or infrequent modes of operation of the EUC. If the hazard analysis identifies that malevolent or unauthorized action, constituting a security threat, as being reasonably foreseeable, then a security threats analysis should be carried out.*

### >> Podcast: What is Edge Computing, and Is It for You?

In *The Journal* magazine's latest Automation Chat podcast episode, "What is Edge Computing, and Is It for You?" Executive Editor Theresa Houck talks with Jason Andersen, Vice President of Strategy and Product Management at Stratus Technologies. We answer the question many people ask: What is edge computing, and how is it different from the cloud? You'll learn how to know if it will help you; what's involved in implementing it; and get examples of it at work in real companies.

Jason also describes how OEMs are using edge computing to provide new capabilities for customers.

Listen on your favorite podcast app, on the web at <https://bit.ly/tj20stratuspod>, or watch our conversation on YouTube at <https://youtu.be/SVEzPU5TVGU>.



Considering that most cybersecurity attacks are based on the attacker simply finding a vulnerable target — rather than being specifically targeted because of industry or prominence — a cybersecurity attack is a foreseeable circumstance in virtually every industry. Assessing your cybersecurity risks, determining your level of acceptable risk, and mitigating identified risks to an acceptable level are now the basic “reasonable” steps to protect people from foreseeable misuse and malevolent or unauthorized actions.

As with safety, ignoring cybersecurity and associated risks in the mistaken belief that “if I don’t know about the risk, I can’t be held accountable” is not an acceptable posture.

While many security practices have long been used in the IT world, they’re new to the operation technology (OT) world. And, while many of the mitigation steps are similar in comparison, they’re applied very differently in the front office than on the plant floor.

### Change Management

Cybersecurity risks are safety risks. In the modern manufacturing environment, both should be part of risk management and part of the management of change (MOC) process. Environment, Health and Safety professionals should be involved in managing cybersecurity processes and compliance with standards and the law.

It’s a new age in industry. The advantages of Industry 4.0 certainly outweigh the increased risks. Understanding the risks and mitigating them is part of the plan. □





# HOW DCS MIGRATION SAVES WASTEWATER PLANT OVER \$34K A YEAR

Modernizing its legacy system helped the City of Tacoma improve real-time visibility into operations, ease troubleshooting and reduce energy costs.

➤ Wastewater isn't just the water flushed from toilets or drained from bathtubs. It comes in many forms, including rainwater from storms, which can carry chemicals and other substances that could cause harm if used before going through the wastewater treatment process.

Tacoma, a city south of Seattle in a state known for its year-round rainfall, knows the importance of proper water and wastewater treatment to keep its more than 208,000 residents serviced and safe.

The City of Tacoma Environmental Services operates two wastewater plants, the Central and North End plants, which maintain 48 pump stations along a 650-mile collection system when combined.

The Central treatment plant was built in 1954 with secondary treatment upgrades completed in 1988 to meet new effluent standards from the U.S. Environmental Protection Agency (EPA). In 2006, additional upgrades

were implemented to increase the plant's capacity to 139 million gallons per day (MGD).

The North End treatment plant, built in 1968, has a capacity of 30 MGD. Major upgrades were completed in the late 80s to meet requirements from the EPA mandate, and secondary treatment upgrades were added to the plant in 1997. Unique from other wastewater facilities, the North End plant is a physical/chemical treatment plant because of its smaller footprint and transfers solids to the Central plant for processing.

Both plants were operating on decades-old equipment and required upgrades.

"We were dealing with legacy systems that no longer suited or supported our operations," says Chris Roberts, Tacoma Automation Support Team, City of Tacoma Environmental Services. "It wasn't a 'want' but a 'need' to find a new solution for both the Central and North End plants that would make smoother, more efficient processes possible."

## The Prep Work Begins

The city collaborated with Carollo Engineers, an environmental engineering firm specializing in the planning, design and construction of water and wastewater facilities, to help with the technology selection process. The combined team evaluated different solutions' capabilities, support services, associated costs and more. After the extensive selection process, the PlantPax<sup>®</sup> distributed control system (DCS) from Rockwell Automation came out on top.

"We wanted a solution and a partner that would offer the hands-on support we needed as a smaller player in the DCS world," Roberts says. "Through our research and evaluation, we found that Rockwell Automation had the local programming and technical support we were looking for with a competitive price point."

Once the technology selection process was completed, the team continued working with Carollo Engineers to prep for system implementation. This included building out system standards, understanding potential unknowns in the aging systems, creating all new piping and instrumentation diagrams (P&IDs) and control narratives and pinpointing exactly how to take the proof of concept to an implementable design at both plants.

After a three-year preparation period, the city was ready to implement a fully standardized PlantPax DCS and production intelligence solution to help increase plant efficiencies, save energy and improve visibility into its operations.

## Out with the Old

The flexible, modern DCS provides a plant-wide solution with predefined code and faceplates that improve ease of use for operators. The detailed Library of Process Objects with add-on instructions (AOIs) allows for a standard method of operation, decreases engineering deployment time and simplifies integration of non-Rockwell Automation devices.

"Our operations team requested modified, customized graphics to align closer with the grayscale standard but allow for more color to match the existing color schemes of the plants, and because of the flexibility of the PlantPax system and its object library, we were able to easily do that," said Roberts.

The team implemented historian and production intelligence software to improve the operator's view into key process and performance data. The historian collects and archives valuable data from each plant's equipment and instrumentation, and operators now have automated

reporting capabilities and an easy-to-understand view into historical and real-time process trends, such as pumping metrics, and all process operations from the control room.

The team also installed 22 new programmable logic controllers (PLCs) along with an Industrial Data Center (IDC) from Rockwell Automation to help decrease server footprint and improve infrastructure reliability. The IDC is a standard preconfigured infrastructure that offers a virtualized environment for testing configuration and software changes without impacting production, which was a must-have for the city. It also bundles technology from leading IT providers and Rockwell Automation Strategic Alliance Partners, Cisco<sup>®</sup> and Panduit.

The implementation process for the full solution and cutover took just two years, with only a few additional upgrades planned for pump stations.

## New Visibility

The modern DCS helped the city see into their process more clearly. With the new system, the city is working on implementing a predictive maintenance strategy versus reactive. If an alarm went off or any issues arose with the legacy systems, operators would have to physically go inspect what was happening. Now, they have contextualized data through the process software in the central control room, which decreases troubleshooting time and costs associated with operational delays.

The number of alarms, ranging in severity from nuisance to critical, improved with the new system. This helps ensure everything runs properly and allows operators to preemptively address any potential issues.

"Our operators now have more data available to observe, and it's organized in a way that allows them to understand what's happening at any stage of the process," says Roberts. "The standardized language and graphics make it easier to document the process and key data points, as well."

Energy data from the modern DCS feeds information to the energy management team to help identify sources of power savings. Currently, this team has identified over \$34K/year of savings. This helps the city meet its power-saving goals by better equipping the energy management team to analyze processes and uncover potential efficiencies, such as lowering the pressure setpoint to reduce the number of pumps needed, which therefore saves energy.

"We're always aiming to identify better, more efficient ways to run our plants, and the modern DCS system we have now is helping us do just that," Roberts notes. □



# CYBERSECURITY RISK MANAGEMENT: LESSONS LEARNED FROM THE REAL WORLD

High-profile cyberthreat events have involved plant control-room computer systems accidentally infected with a virus or ransomware, so it's vital to update your cybersecurity and know your vendors' security practices.

By Bruce Billedeaux, P.E., senior consultant at MAVERICK Technologies

**>>** The 2019 book, *Sandworm: A New Era of Cyberwar and the Hunt for the Kremlin's Most Dangerous Hackers*, by Andy Greenberg, is an excellent primer into the concept of collateral damage as it pertains to cybersecurity and risk. Greenberg explores the multifaceted attack Russian hackers used on Ukrainian networks and electrical infrastructure. He explains in frightening detail how hackers targeted the Ukrainian power grid and took control of networked overcurrent relays by opening them remotely, causing Kiev to be plunged into complete darkness.

Although the grid takeover is incredibly frightening, this article isn't about that direct attack. Instead, let's look at the correlating issue: the damage caused by infiltrating ransomware installed through a server update. Ransomware is a type of software that encrypts the contents of a computer's hard drive and demands payment, or ransom, to restore the data.

For example, Maersk, the global shipping giant, became infected with the NotPetya ransomware. The ransom-

ware's spread was so quick, it reached every corner of the network in just a few hours. No computer on the network was spared. The estimated revenue lost was between \$200 and \$300 million.

The amount of damage done, and the speed at which it occurred, leads us to several questions. First, was Maersk targeted by a nation-state? As it turns out, Maersk was not specifically targeted. It was discovered the hackers infiltrated a small Ukrainian accounting software company's server. That server is used to update hundreds of client software packages throughout the country.

Unfortunately for Maersk, its Ukrainian agent used this accounting software. The software automatically was updated, and this allowed the ransomware to enter the Maersk network.

The next question that comes to mind is, did Maersk's IT department fail in some way? Maersk's IT security department was considered to be world class at the time of the attack. It was not an IT department failure that





allowed the ransomware to ravage its network. Rather, the Russian hackers employed a zero-day exploit, which allowed the ransomware to bypass security features in a network. A zero-day exploit is developed specifically to exploit risks unknown to the IT hardware and software vendor.

In fact, the damage sustained by Maersk was the result of the Russian hackers' effort to disrupt the business sector in the Ukraine. The ransomware was sophisticated and set to execute at a time after the software update. The ransomware then obscured its source. From this information, we can conclude that all the damage Maersk incurred was collateral damage.

Other high-profile events have involved plant operator control-room computer systems that have been accidentally infected with a virus or ransomware. In all these cases, the company affected was not targeted. This means that you don't need to be targeted by an attack of nation-state quality to be a victim. Therefore, knowing your vendors' security practices is becoming more important than ever.

## ISA Cybersecurity Standards

The ISA cybersecurity standards for industrial automation is ISA-62443, *Security for Industrial Automation and Control Systems*. This standard offers several security requirements that address this issue. The following three requirements specifically address Industrial Automation and Control Systems (IACS) vendors and integrators:

- Part 2-4: *Requirements for IACS solution suppliers* covers the policies and procedures of integrators. It covers their

security practices, including everything from personal requirements to how your project is stored on their servers and how an integrator receives patches and updates.

- Part 4-1: *Product development requirements* describes how the IACS manufacturer develops its products to ensure all known risks are mitigated during development. It's imperative the risks be mitigated during development because it becomes nearly impossible to remove them once they are embedded in a product. It is, therefore, crucial for your vendor to have substantial security during development.
- Part 4-2: *Technical security requirements for IACS components* describes the best practices for IACS vendors to implement in their products to mitigate risk. Many of these requirements center around policy enforcement, for example, a policy requirement prohibiting back door or development passwords from being common across all the vendor equipment. Another common policy is the requirement that the default password be changed the first time the product is used.

## Cost-Benefit Analysis

A cost-benefit analysis must be done when assessing cybersecurity. It's tempting to just reference these or similar standards in the contract terms or on the purchase order; however, this is unlikely to mitigate the risks to a facility's systems effectively.

All standards have multiple levels of compliance, ranging from awareness to full conformity, requiring following the most stringent provisions in the standard meticulously. A vendor might state it is "compliant" with a standard by just being aware of the steps it should take to ensure a secure solution, without actually performing any action to mitigate the risk.

### >> Podcast: Edge Computing Meets IIoT

In *The Journal* magazine's Automation Chat podcast, "Edge Computing Meets IIoT," John Clemons with system integrator Maverick Technologies discusses developments with the IIoT, how it's enabled by edge and cloud computing, and how users can use it for digital transformation, especially in light of the COVID-19 crisis. Listen to this episode on your favorite podcast app, or on the web at <https://bit.ly/3ehqDwc>.

An excellent cost-benefit analysis, which includes the different possible levels of compliance, is in ISA-62443 Part 3-2 *Security risk assessment and*

*system design*. How much risk can your operation tolerate compared to the cost required to mitigate those risks?

It might be surprising to discover the high cost of the practices required to legitimately achieve compliance. A company requesting a bid, in which it is stated that an automation vendor or integrator must meet all the requirements in Part 2-4, 4-1 or 4-2, will discover the expense required to achieve those goals legitimately.

### Third-Party Certification

All customers who desire an IACS vendor and integrator to install a secure compliant system should require the vendors or integrators to have third-party certification stating what level of compliance they have achieved. Do the parts of the standard in which the vendor is certified meet your own cybersecurity requirements?

Good vendors and integrators can help guide you through this analysis during the initial design of your project. They can also help identify the parts of the standards that mitigate the risks your automation system specifically faces.

It's now more imperative than ever to address the issue of security with your vendors and integrators. Your facility might be the next target unless you know your vendors' and integrators' cybersecurity practices. Don't become a hacker's next victim. Get your cybersecurity up to date and ensure all vendors and systems integrators are onboard to help mitigate cybersecurity risk. □

*MAVERICK Technologies, a Rockwell Automation company, is the largest independent systems integrator in North America and a global leader in industrial automation, enterprise integration and strategic manufacturing solutions for clients across a range of manufacturing and process industries.*

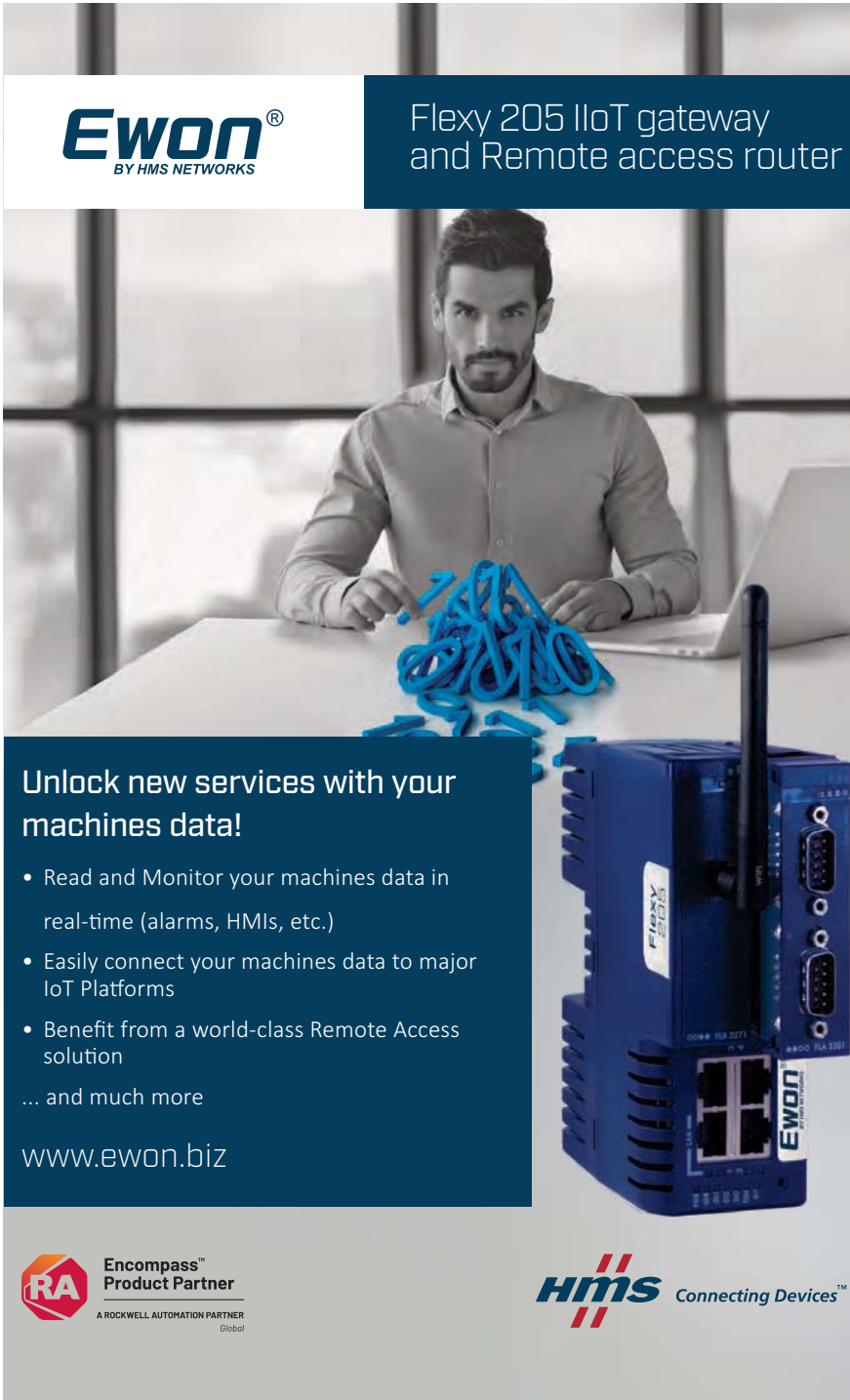

**EWON**<sup>®</sup>  
BY HMS NETWORKS

## Flexy 205 IIoT gateway and Remote access router

### Unlock new services with your machines data!

- Read and Monitor your machines data in real-time (alarms, HMIs, etc.)
- Easily connect your machines data to major IoT Platforms
- Benefit from a world-class Remote Access solution

... and much more

[www.ewon.biz](http://www.ewon.biz)

**RA** Encompass<sup>™</sup> Product Partner  
A ROCKWELL AUTOMATION PARTNER Global

**Hms** Connecting Devices<sup>™</sup>

# Harmonic Distortion



REMAINING CAPACITY

REAL WORK

TOTAL SYSTEM CAPACITY

## WHY DOES IT MATTER?

### It's all about power quality

Non-linear loads distort the sine wave. The distortion in this wave becomes a power quality issue. This can increase utility costs and reduce the reliability of equipment.



### #1 ISSUE

That leads to increased unplanned downtime and reduced productivity

### EQUIPMENT IS NEGATIVELY AFFECTED

Harmonics can lead to heating everything connected to distribution system resulting in breakdown or failure

## THE PROBLEMS



### UTILITY COMPANIES

May have requirements for Total Harmonic Distortion and will charge for poor power factor



### IN YOUR FACILITY

Manufacturers that don't correct for reactive and harmonic currents may need to oversize their electrical infrastructure

Consider harmonic mitigation

If your non-linear loads are above **>20%**

or

If you must comply with **IEEE 519**

## THE SOLUTION

### CUMULATIVE

When a group of small AC drives are connected to a single distribution system, an active filter can help reduce harmonics cumulatively.

### INDIVIDUAL

Mitigate individually to solve harmonic issues at every source of distortion, ultimately avoiding the cumulative effects.

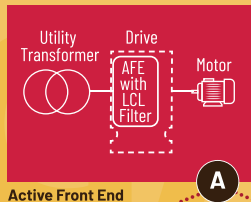

Active Front End

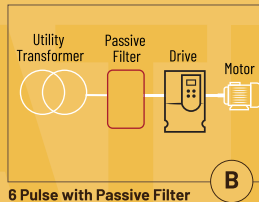

6 Pulse with Passive Filter

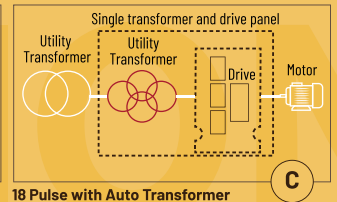

18 Pulse with Auto Transformer

## What Solution is best for me?<sup>1</sup>

Performance<sup>2</sup> **A** ●●●●●

Cost **A** \$\$

Footprint **A**

**B** ●●●

**B** \$\$\$

**B**

**C** ●●●

**C** \$\$\$\$

**C**

<sup>1</sup> Comparison is based on a typical 200Hp drive configuration. Comparison may vary based on drive power rating.

<sup>2</sup> Percentage of distortion mitigation AFE technology also provides power factor correction and power ride through.



200 Hp drive

Mitigate Harmonics with Active Front End Technology in the **PowerFlex® 755TL Drives**



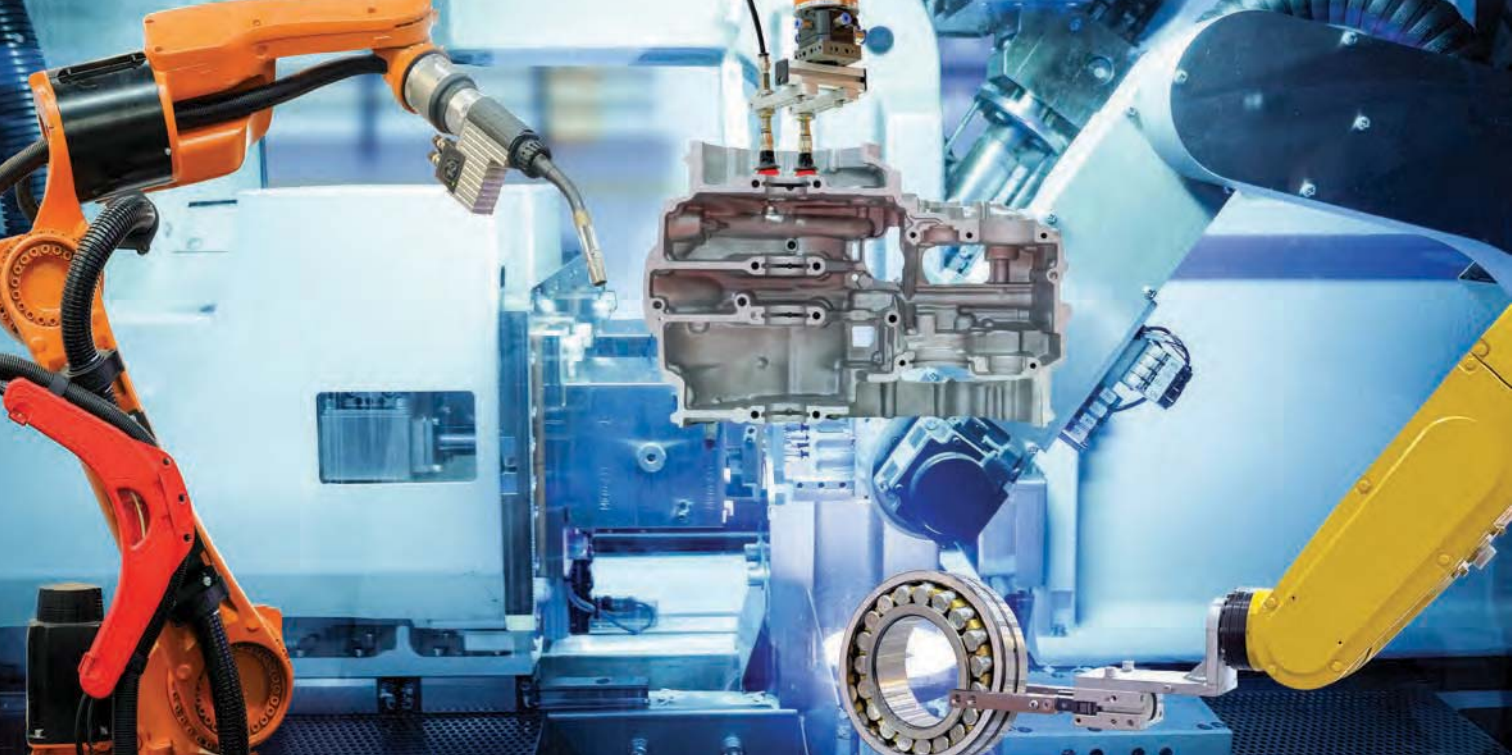

# HOW VIRTUAL COMMISSIONING CAN BUILD FASTER, SAFER MACHINES

Learn how an injection molding machine maker eliminated oscillation issues during production and reduced its machine cycle time by more than 25%.

By Chris Harduwar, Vice President of Business Development, [Maplesoft](#)

*Editor's Note: This article is adapted from a comprehensive case study, "Using Virtual Commissioning to Develop Faster, Safer Machines for Less," from Maplesoft. Download the far-reaching application story at <https://bit.ly/mapleuptj20> to get details about the machine design and oscillation; virtual commissioning requirements; controller code and PLC design; development environment; and detailed illustrations.*

**>>>** In industrial automation, speed and efficiency are everything. Engineers are constantly looking for new techniques to increase production speed without sacrificing safety or quality.

To improve machine performance, many engineers look to new motors, hydraulics and other components that can withstand more demanding requirements. With virtual commissioning, engineers at [Niigon Machines Ltd.](#) are

making their machines perform faster, safer and more efficiently by using simulation-based design principles.

As a provider of injection molding machines, Niigon delivers modular, customizable machines to a competitive market. The company recently delivered a new machine that ran two injection units in parallel, taking advantage of both hydraulic and electric actuation to press the molds together. Once delivered, its customer required a faster throughput than was currently achievable for the machine.

## Oscillations Forcing Machine Slowdowns

In its current configuration, the machine speed was limited by unwanted oscillations that appeared at higher production speeds, making it necessary to run the machine slower than the customer's specification. These oscillations, acting on the center platen, would appear during

the portion of the machine cycle when these platens were closing together.

With current engineering techniques, a solution would require replacing its hydraulic components with electric counterparts, which came at the cost of hardware, hundreds of engineering hours, and significant losses because of machine downtime.

Faced with high costs and tight deadlines, Niigon decided to consider a new approach. Company leaders worked with Rockwell Automation Encompass™ Product Partner Maplesoft, a provider of simulation and virtual commissioning solutions, to find a way to optimize its control strategies with simulation-based techniques.

Virtual commissioning of a machine's dynamics generally combines three important pieces:

1. A **digital model**, sometimes referred to as a digital twin.
2. The **controller code** that governs the motion and response to sensor feedback.
3. The **development environment** that allows the two to be run together.

The digital model is a virtual representation of a corresponding physical product. It can be used to simulate, predict and analyze machine performance.

In contrast, by using a system-level modeling tool, creation of a model-driven digital twin can begin alongside the design process. Meaningful digital twins can be created before a physical product is finalized, allowing for a powerful test platform to validate product performance earlier than ever, for important tasks such as sizing servo drives, motors and gearboxes, and validating the mechanism design.

## Glance at the Process

To get results as fast as possible, Niigon asked [Maplesoft Engineering Solutions](#) to help develop and implement a simulation-based upgrade to their machine. They developed a validated machine model, investigated the underlying causes of oscillations, and then used the simulation model as a virtual test platform for optimizing machine controllers.

By doing its control optimization virtually, Niigon could develop, test and optimize multiple strategies without taking the physical machine offline or risking machine damage during testing. Once a suitable strategy was developed, the physical machine was updated remotely with the new software.

To create the simulation model — also known as a digital twin — Niigon provided Maplesoft with a variety of operational data from its machine, including veloci-

ty, position and torque data from different components. Using Maplesoft's MapleSim modeling and simulation tool, a dynamic model was created to replicate the physical machine's operation.

By comparing the physical machine data with the model results, engineers at Maplesoft created a simulation model that accurately replicated the oscillations seen on the physical machine. They could use this model to investigate the cause for oscillations and simulate a variety of strategies that could eliminate them.

Niigon was now ready to use its simulation model to develop new, optimized control code for the machine. By testing against a virtual machine, it could run countless iterations of control strategies offsite, and without the physical machine.

## Exceeding Customer Expectations

Armed with the promising results from their model-based optimizations, engineers from Niigon and Maplesoft were ready to implement their solution on the physical machine.

In a typical commissioning situation, engineers might take weeks or months to settle on a suitable controller configuration. However, because Niigon performed its testing on the virtual machine, they required less than two days of machine downtime to implement optimizations to their machine operation.

Niigon machines successfully reduced the machine cycle time by more than 25%, and effectively eliminated the oscillation issues during production. In addition, by using virtual commissioning as an automation technology, Niigon could deliver a machine that exceeded its customer's performance requirements, with less machine downtime and less than 25% of the cost of hardware-based solutions.

In a matter of months, machine simulation went from a hardly considered option to an important tool for future engineering developments at Niigon. □

### >> Download the White Paper

Visit <https://bit.ly/maplewptj20> to download the comprehensive case study, "Using Virtual Commissioning to Develop Faster, Safer Machines for Less," from Maplesoft. Get additional information about the molding machine's design and oscillation challenges; virtual commissioning requirements; the role of controller code and PLC design; development environment; and detailed illustrations.



# CASE STUDY: BEVERAGE GIANT INCREASES THROUGHPUT BY USING BATCH MANAGEMENT & PROCESS CONTROLS

The major soft drink producer replaced outdated systems and chose an infrastructure for digital transformation to keep up with syrup demand and allow for future products.

*By Sheila Kennedy, Contributing Writer*

➤ In soft drink manufacturing, syrup production is a critical operation. If the supply of this concentrated ingredient is interrupted, the beverage's production will come to a halt. When a vital U.S. plant for a global beverage company was struggling to keep up with demand for its most popular syrup, it set out on a path to replace outdated systems and chose an infrastructure for digital transformation.

The new architecture, including a modern soft drink batch system and distributed control system (DCS), not only increased production throughput and reliability, but it provided added benefits in safety, batch reporting and complex recipe management.

With the new solution designed and developed by McEnery Automation, a Rockwell Automation Recognized System Integrator, the plant now has the scalability and flexibility to accommodate current performance objectives, rising consumer demand and future product innovations and expansion.

## Wholesale Improvements Needed

The U.S. soft drink facility is the primary provider of the company's signature syrup, making it crucial to the overall beverage production network. It's an older plant built to produce large batches of several products. Its control system had been in place for more than 15 years, making maintenance, modifications and expansions a challenge. Manual entry of recipe setpoints and ingredient additions also was cumbersome and risky.

Over the years, demand for flavor innovations widened the variety of recipes and brands the plant produced. Global sales



growth pressured the plant to eliminate process bottlenecks, boost output and take measures to ensure its manufacturing process is repeatable and reliable and able to produce high-quality products consistently.

The plant conceived a project encompassing process equipment modifications and a control system upgrade. Essentially, the heart of the manufacturing process was to be replaced. Furthermore, the implementation had to fit within a short production outage, including interfacing with new OEM-provided process skids and existing plant systems, such as clean-in-place (CIP) and raw material delivery.

Successful, timely completion of the project would require assistance from a systems integrator with significant food and beverage industry experience and specific credentials in industrial process control systems.

## An Infrastructure for Digital Transformation

The soft drink manufacturer chose McEnergy Automation, a CSIA Certified System Integrator, as its integration partner to update its syrup-making process and architecture. McEnergy Automation has extensive food and beverage control system experience and strong working relationships with Rockwell Automation and major OEM providers.

“Our engineers took time to fully understand the plant’s existing process systems, risks and priorities before designing an infrastructure solution that ultimately surpassed the plant’s goals and provided a roadmap for their digital transformation journey,” says Kevin McEnergy, CEO of McEnergy Automation.

A series of process modifications were targeted to eliminate process bottlenecks and tank capacity limitations. This included adding an in-line blender just before the filler to create finished product; installing a new OEM-supplied automated hand-add mix station to reduce operator tasks and increase mixing consistency; and reconfiguring existing mix tanks, piping and instrumentation to produce high-concentration intermediate batches.

For its new control system architecture, a modern, scalable Rockwell Automation-based solution was chosen, including:

- PlantPAX® DCS system and its library of process objects.
- FactoryTalk® Batch, an ISA-S88 platform for batch and recipe management, batch sequencing and batch reporting.
- FactoryTalk View SE, the primary batch operator interface, for one workstation (future expansion is anticipated).

- Allen-Bradley® PanelView™ located on the CIP station.
- Allen-Bradley ControlLogix®, the primary controller.
- Allen-Bradley Stratix® 8000 and 5700 managed switches.
- Thirteen Allen-Bradley PowerFlex® 525 variable-frequency drives (VFDs) with integrated safety circuits.
- Microsoft® Hyper-V redundant virtualized server system for the Rockwell Automation software.

The new solution went live in early 2019. “Scalability and flexibility were crucial goals. We were able to start small and put the right infrastructure in place, knowing it can easily be expanded and built upon without having to tear it all out and start over,” says McEnergy.

“The scalability of the Rockwell products made it easy for us to put an architecture and framework into place that will allow for the addition of more batch system units, PLCs, software licenses, operating stations and screens in the future, knowing it will all work together seamlessly.”

## Immediate, Future and Unexpected Benefits

Production capacity increases and performance improvements have exceeded the plant’s expectations. Eliminating bottlenecks and relieving batch tank capacity limitations more than doubled the plant’s throughput. Batching a higher-density intermediate product reduced the number of required batches and the time operators spent on batching by well over 50%.

Automated recipe entry and management and dramatically reduced process intervention are increasing batch accuracy, reducing the risk of human error and cutting time spent on corrective adjustments. Operators now have more time to monitor equipment for proper operation and identify further improvements.

Making all controls, alarms and process data for the entire system available at one location allows operators to do their jobs centrally instead of walking to the equipment to monitor the process. New switches reduced network traffic and enabled tighter integration between the controllers and network. The redundant server configuration is increasing reliability and scalability.

FactoryTalk Batch and PlantPAX are providing a tightly integrated batch and process control environment. The new mix station’s CompactLogix is integrated tightly with FactoryTalk Batch and ControlLogix.

FactoryTalk Batch provides recipe procedures and addition setpoints, and Recipe Editor’s Expression Builder performs complex formulation calculations. These system-produced actions improve accuracy and product quality substantially.

FactoryTalk Batch's built-in capabilities for reporting and material tracking and tracing provides further benefits. Batch reports automatically

are capturing addition amounts, run times, alarms and events, thus facilitating batch troubleshooting and improving system performance.

Maintenance technicians are using PlantPAx objects for troubleshooting instead of accessing PLC programs. PlantPAx graphic objects on the batch workstation and CIP PanelView are providing a consistent look and feel for simplified operator actions and training. With the new VFDs, pump speeds are reduced before reaching addition cutoff, improving addition accuracy. And softer starting and stopping rates are helping to extend pump life.

One of the project's hidden benefits is how the system's layout brought the ingredients closer to the mixer, making transport safer and more convenient and the ingredients less prone to damage and handling.

"Better layout, better process design, better technology — it all contributes to increased throughput while reducing all of the things we don't want to happen, such as product variability, process misalignment and even the potential for employee injury," observes McEnergy. "With less time spent on recipe management, process intervention and ingredient transport, those operators are free to concentrate on other value-add work."

Together, the process equipment modifications and modern control system have established a solid foundation for the soft drink producer to meet current production objectives, make future products and keep up with global demand. □

*McEnergy Automation, a Rockwell Automation Recognized System Integrator, has been delivering automation projects in North America for more than 25 years. The CSIA Certified System Integrator has extensive batch and process control experience and uses the Rockwell Automation Integrated Architecture® system to integrate the plant floor with business information system functions.*



## What to do when analog won't do?

### Get the *ReadyLink*™ Network LDT

Automation solutions require accurate feedback of continuous position regardless of the application environment. Analog position sensing devices can have shortcomings in automation applications, including limited features, resolution and cable lengths. That's why the *ReadyLink* Linear Displacement Transducer is a far better solution. Feature for feature, it lets you do—and measure—so much more.



- Magnetostrictive noncontact technology; resolution to 1 micron
- Wide input power supply range (7–30V) may reduce external power supply requirements
- Supports Star, Line or DLR topology
- Three standard M12 connectors — 1 power, 2 communications
- RapidRecall™ module stores all user configuration settings
- Five status LEDs monitor LDT and network status
- Status bits warn of position/velocity outside of programmed range
- Built-in web pages for easy configuration
- Set IP address from network PC or the last octet via the RapidRecall DIP switches

Learn more about this smart device technology at [ametekfactoryautomation.com](http://ametekfactoryautomation.com).

© 2016 by AMETEK. All rights reserved.





# 3 KEYS TO AUTOMATED WEIGHING ACCURACY

Learn how to automate machines with weight-based control using less hardware while helping users achieve high levels of quality and operator safety.

By Jeff Holcomb, Global Automation Market Manager, [METTLER TOLEDO](#)

*Editor's Note: This article is adapted from a comprehensive white paper, "Meet the Speed Challenge: Six Keys to Automated Weighing Accuracy." Download full paper at <https://bit.ly/mtwptj20> to get comprehensive information about the six key considerations when creating machines that function along the automation measuring chain, why they're important, and notes and illustrations to help you avoid many of the most critical pitfalls when using weight-based control.*

**>>>** Weight-based control can help machine builders and system integrators provide higher productivity and consistency of results compared to other means. Also, weight sensors or scales don't physically contact the products they're measuring; this avoids cleaning

and risk of cross contamination. While this method can be used for processes measured in minutes or hours, it can also offer advantages for high-throughput systems with processes measured in seconds or less.

If your company is developing a weight-based automated control system, there are six key considerations when crafting machines that function along the automation measuring chain:

1. Latency.
2. Filtering method.
3. Communication type.
4. Networking requirements.
5. Controller capabilities.
6. Actuator optimization and material.



This article addresses the first three of these six factors. Download our white paper at <https://bit.ly/mtwptj20> to get details about all six considerations.

### **1. Latency: How quickly does the measuring device you are considering react to changes in weight?**

Consider how fast your device, or system, reacts to a change in weight. If you're a designer who expects higher productivity and better quality, latency is your most critical factor. Low-latency devices are devices that can provide the highest accuracy — trueness and repeatability — in the shortest time so your control system can make precise decisions in the right moment.

Low-latency devices allow you to profile material flow so precisely that you can refine control variables and algorithms. A true low-latency device is one that provides what you want in your programmable logic controller (PLC) to make control decisions in less than 10ms. In other words, if your systems are decentralized, then your weighing devices must complete the input-decision-output cycle in this timeframe. This allows you to control your feeding valve, gate or conveyor with a high degree of precision.

For example, low latency allows you to eliminate “slow” speed filling valves or feeders and accurately control with only one material feeding device while simultaneously increasing the speed of your system.

When choosing a weighing device to place in your design, test the complete scale or sensor for its latency and see if it meets your process requirements. For best results, this can mean assessing the whole measuring system: the scale, sensor(s), and terminal or transmitter that interprets the weight for the controller.

It's also important to choose high-quality components for repeatable and reproducible results. Some companies eliminate critical weighing hardware to save cost only to find that the machine's precision and speed (latency) has been compromised. For example, a simplified weighing device reacts slowly because of mechanical instability, electromagnetic interference or hypersensitivity to vibration.

### **2. Filtering Method: Does the device provide active or adaptive filtering?**

Many weighing installations are in environments with vibration caused by moving parts, mixers and agitators. A weighing device with a fast-active filter allows your system to continue providing accurate results when the environment isn't perfect.

Avoid fixed or averaging filters that increase system latency, slow down your process and cause inconsistent

results. These filter types don't provide the kind of precise adjustment required for low latency because they rely on an average versus showing you the **actual weight minus the vibration component**.

When you review device specifications, look for any tables that show significant system speed reductions when filtering is enabled. Many devices on the market use slow fixed or averaging filters and aren't ideal for high-accuracy, high-speed automation. If you chose a product with a fixed filter, you'll need to slow down your process to get an accurate result; therefore, chose a product with a fast filter to gain the highest throughput.

### **3. Communication Type: Will the weighing device send weight data cyclically?**

Acyclical communications (one command — one response) should be avoided if processing speed is your goal. Sending weight data cyclically will confirm the fastest speed possible.

When data is received in a floating-point format, your system can easily compare incoming data in your control algorithm without reprocessing the data or looking for decimal points.

Include critical cyclical data bits such as alarm, heart-beat, motion, center-of-zero, and data ok status help to verify that your system is secure and stable, and your weight is fault-free. □

*METTLER TOLEDO is a participating Encompass™ Product Partner in the Rockwell Automation PartnerNetwork™ program. Based in Switzerland, the company provides weighing solutions that include industrial weigh modules, load cells and PLC connectivity devices that easily integrate weight into automated applications.*

## **>> Download the Comprehensive White Paper**

Visit <https://bit.ly/mtwptj20> to download free white paper, “Meet the Speed Challenge: Six Keys to Automated Weighing Accuracy,” from Mettler-Toledo. Get comprehensive information and illustrations about six key considerations when crafting machines that function along the automation measuring chain, why they're important, and notes to help you avoid many of the most critical pitfalls when using weight-based control.

# HOW DIGITAL TWO-WAY RADIOS SUPPORT SMART MANUFACTURING

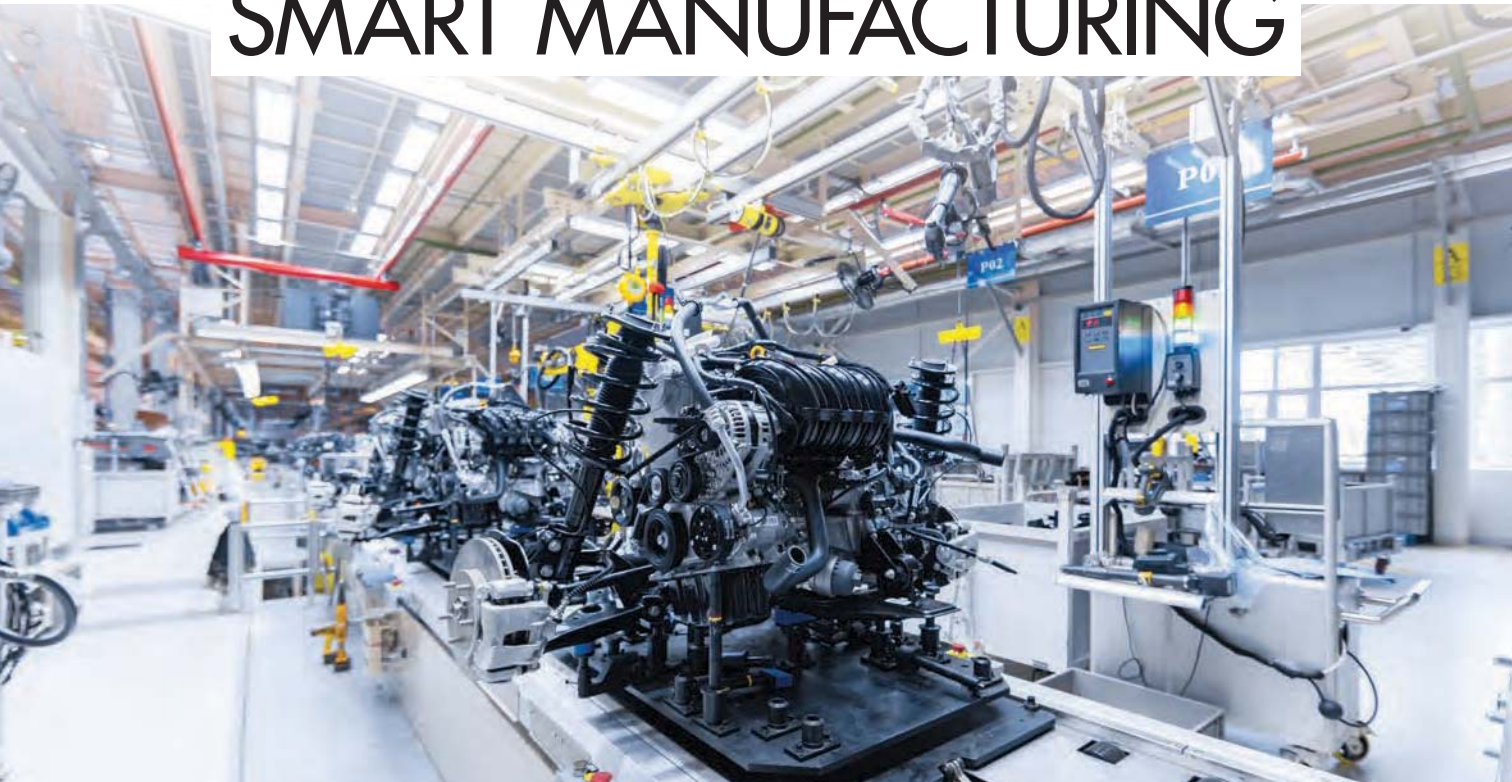

We examine how these radios can help minimize downtime and improve efficiency and safety by unifying voice, video, data and analytics.

From [Motorola Solutions](#)

*Editor's Note: This article is adapted from a white paper, "Take Business Critical Communications Further: 5 Strategies in Connected, Smart Manufacturing." Download the full paper at <https://bit.ly/motorolawptj20> to learn how moving from analog to digital two-way radios can help keep workers safe and improve efficiencies. Find out how teams can communicate across different devices and networks; how digital radios provide an entry point to integrated applications such as incident management as well as video and security, dispatch, work ticketing and more; how they can extend coverage coverage, capacity and security than Wi-Fi for data, voice and video; and more.*

**>>** It has never been more essential or challenging in manufacturing to operate safely and efficiently while ensuring production continuity. From juggling day-to-day issues to optimizing production while

also innovating new products, manufacturers have also found themselves adjusting to new safety and operational requirements in the wake of COVID-19.

At the same time, industrial firms rely on many disparate systems and devices to get the job done, each with a unique role to play in safety, productivity and efficiency. Yet different devices, networks and technology systems in the factory and throughout the supply chain can keep business-critical information in silos. This results in limited communication and collaboration, delayed responses to issues, a heavier burden on your IT department, and different vendors managing each solution.

Let's look at three important reasons digital two-way radios and other technologies can expand business-critical communications for smart manufacturing.

## Digital Radio Usage on the Rise

Radio communication remains a critical foundation for manufacturers, and the future is digital two-way radios. While some manufacturers still rely on legacy analog hardware, the number of digital radio users in the industry has almost doubled in the last two years, according to Motorola Solutions 2019 Manufacturing Communications Survey Report. In fact, 70% of survey respondents indicated they're already using digital radios in some capacity, and more than half said they expected to fully adopt digital radio communications within the next 5 years.

## Connected with Communications

The speed and complexity of manufacturing demands more from communication than simply a voice conversation. It requires intelligence and useful applications that help automate tasks and expedite assignments.

In the survey, manufacturing workers indicated that text messaging and alerting, and work order and job assignment applications, would be the most helpful on the job. Indoor location tracking, alarm and event management, Industry 4.0 and Internet of Things-powered applications were also key selections. Moving from analog to digital radio communications provides an entry point to a range of integrated applications and solutions that can unify communications from end-to-end, transforming the way manufacturers operate. This includes video and security, dispatch, work ticketing and more.

When it comes to safety and security, manufacturing operations have unique needs. Worker safety and security. Hazardous machinery and heavy equipment. Diverse areas to monitor both inside the plant and outside and across multiple buildings. This makes safety and security a top challenge.

In our survey, workers listed video surveillance and access control as the top two security capabilities their companies use. But only 5% said their company used video analytics. This highlights a great opportunity for manufacturers as advances in artificial intelligence (AI), machine learning and analytics are helping transform video security, offering more visibility and insight with much less effort.

## The Wi-Fi Challenge

The demand for data in manufacturing is limitless. While industrial firms turned to Wi-Fi as a valuable tool to support their data needs, an increasing number of devices and evolving needs are highlighting some disadvantages of Wi-Fi for business-critical installations. As a result, manufacturers using smart manufacturing strategies integral to safety, production and operations need a reliable solution for all their data, voice and video needs.

To address these challenges, the U.S. Federal Communications Commission (FCC) has approved the use of a new type of radio spectrum to complement Wi-Fi: Citizens Broadband Radio Service (CBRS). CBRS is based on LTE technology and operates on a 150 MHz slice of the 3.5 GHz radio spectrum that was formerly underutilized by U.S. government satellite and radar systems. Unlike Wi-Fi, CBRS enables private LTE broadband for your manufacturing facility, enabling better coverage, capacity and security.

With CBRS, spectrum is not shared. This allows businesses to use fewer, but ultimately more powerful, transmitters. A single CBRS access point can cover the same large area as five or six Wi-Fi access points would have — requiring fewer installations and lower maintenance costs. Because CBRS is based on LTE, devices are optimized to deliver seamless handoffs between access points, which has traditionally been a challenge for Wi-Fi devices as employees move between floors in a building or from one building to another.

CBRS also is inherently more secure than Wi-Fi, using SIM cards instead of SSIDs. Network administrators have complete control over network access and can easily disable SIMs if needed to protect enterprise and device security. Considering the increased capabilities, cost savings and security, CBRS is an enticing option for manufacturers. □

*Motorola Solutions is an Encompass™ Product Partner in the Rockwell Automation PartnerNetwork™ program. Based in Chicago, Illinois, the company provides integrated communication solutions and an end-to-end technology ecosystem that unifies voice, video, data and analytics on a single platform.*

### >> Download the Comprehensive White Paper

Visit <https://bit.ly/motorolawpj20> to download the white paper, "Take Business Critical Communications Further: 5 Strategies in Connected, Smart Manufacturing," from Motorola Solutions. Learn how: moving from analog to digital two-way radio communication can help improve safety and efficiencies; teams can communicate across different devices and networks; digital radios provide an entry point to integrated applications such as incident management as well as video and security, dispatch, work ticketing and more; new data network technologies can provide better coverage, capacity and security than Wi-Fi for data, voice and video needs; and more.



# ENCOMPASS SHOWCASE

## Simplifying Edge Computing for the Connected Enterprise

Modernizing and simplifying operational technologies, capturing and analyzing new sources of data, and extending equipment life cycles are key drivers of productivity in today's connected world. For many, the first step will be virtualizing existing applications and building out a high-availability OT environment that's ready to support new smart connections and IIoT applications. That's where Stratus can help. Visit [www.stratus.com/edge](http://www.stratus.com/edge) and learn how you can bring your automation infrastructure to the edge. <http://bit.ly/2m8osUs>



### STRATUS TECHNOLOGIES

## Premier Integration with Hardy Plug-in Weight Modules

Hardy Process Solutions' single-slot Allen-Bradley® PLC/PAC plug-in weight modules read and condition data from strain gauge load cells and communicate it over the I/O chassis backplane to the processor. They provide basic weight data or are loaded with sophisticated algorithms to perform application-specific industrial weighing processes. Modules are available for ControlLogix®, CompactLogix™, POINT I/O™, Micro800™ or SLC™ 500 chassis. Coupled with Add-On Profiles (AOPs), faceplates/AOIs and sample programs, Hardy's Premier Integration provides comprehensive weight-based measurement and control solutions. [www.hardysolutions.com](http://www.hardysolutions.com)



### HARDY PROCESS SOLUTIONS

## Remote Equipment Monitoring

RACO offers three field-proven remote monitoring products that fully integrate with your existing Allen-Bradley® controllers. Both Verbatim Gateway and Catalyst allow for easy, cost-effective integration with PLCs using Allen-Bradley EtherNet/IP™ and other protocols. Plus, AlarmAgent.com allows for low-cost, wireless, web-based alarm detection and notification that easily integrates into your SCADA/HMI system via OPC. All three provide the peace of mind that comes with knowing your systems are secure. For more information, call (800) 722-6999 or visit [www.racom.com/allen-bradley](http://www.racom.com/allen-bradley).



### RACO MANUFACTURING & ENGINEERING CO.

## Integrated Servo Motor Adds Safe Torque Off

AMCI's SV160E2 integrated servo motor is now available with Safe Torque Off (STO), enabling increased safety across a range of applications. STO prevents unintentional starting or motion. The SV160E2 reduces system costs by eliminating the need for separate components. Move commands are programmed through Studio 5000®, and the SV160E2's EDS files and sample programs help streamline initial set-up and programming. Features include dual port EtherNet/IP™ networking with Device Level Ring (DLR), built-in web server, absolute encoder and virtual axis follower. Call 860-516-8771 or visit <http://bit.ly/2mvdujf> to learn more.



### ADVANCED MICRO CONTROLS INC. (AMCI)

## Reports and Dashboards for Industry

Finally, a reporting solution that gives the information you need, in the form you want, with absolutely no programming. Produce stunning reports using familiar features of Excel workbooks; charts, formats and formulas together with XLReporter's industry-specific functions. Within minutes, your reports are ready to view and email as Excel, Web, PDF files. Easy access to data from RSLink®, FactoryTalk® View SE, Historian, Alarms, VantagePoint, HMS Ewon Flexy and standards such as OPC, ODBC and OLE-DB. Contact us at (508) 520-9957 or [sales@SyTech.com](mailto:sales@SyTech.com). Download a free evaluation from [www.SyTech.com](http://www.SyTech.com).



### SYTECH INC.

## Configure a PLC or Machine Remotely

The Ewon Cosy from HMS Networks is an industrial VPN router that offers the ability to troubleshoot your machines remotely without going on-site, drastically reducing support costs and improving machine uptime. <https://ewon.biz/products/cosy>

### HMS NETWORKS



## >> FLEX 5000 HART I/O Modules

Design and controls engineers can now more easily access, configure and manage HART devices using the new Allen-Bradley® **FLEX 5000™ highly integrated HART I/O modules**.

The simplified programming, available with the Studio 5000 Logix Designer® application, can help simplify design, maintenance and operational productivity.

Integration between the new I/O modules and HART devices can enhance device management, improve diagnostics coverage and provide real-time device health monitoring. The ability to add and replace process devices online can also reduce downtime and improve productivity.

When a machine is being developed, common data structures and

tight integration of instruction sets in the PlantPAx® 5.0 system can minimize design and engineering time. Once a machine is operational, the HART I/O modules can improve overall operational efficiency through increased uptime. A central design environment keeps all work

in one place for a smooth user experience and increased productivity.

The expanded FLEX 5000 I/O options include support for high-density digital, AC and serial modules, and enhance standard and safety I/O control in one platform for extreme temperatures.



## >> Digital, Modular Infrared Thermometers

Encompass™ Product Partner **Advanced Energy**'s Impac Series 600 digital, modular infrared thermometers provide noncontact temperature measurement of nonmetallic or coated metallic surfaces in harsh industrial manufacturing applications.

The thermometers feature a flexible, field-configurable multi-channel plug-and-play design. The multisensor head design, which interfaces with a central hub, allows cost-effective temperature measurement of up to eight points and can be used in power control and optimization of industrial heating applications.

The thermometers are designed for power control and optimization of industrial heating applications in automotive, laminating, injection molding, PET bottle production, packaging and other industrial markets.

Temperature measurement points can easily be replaced or added without the need to return the system to the factory for calibration, reducing downtime and overall cost of ownership. Suitable for measuring temperature ranges between -40 and 700°C, the series comes in three different optics with field of view 2:1, 10:1 or 20:1.



## >> PRODUCT SPOTLIGHT

### Compact Drive System

The compact cyber dynamic system (CDS) from Encompass™ Product Partner **WITTENSTEIN** is a motor-integrated industrial-grade small servo drive system that connects to the PLC in real time via both a CANopen® and a multi-Ethernet interface for EtherNet/IP™ CIP Sync™.

A space-saving, installation-friendly design with electronics integrated in the motor and decentralized intelligence directly on the axis helps generate motions directly in the servo drive, thus relieving the machine's automation system.

The new EtherNet/IP CIP Sync interface supports high-precision motion control applications that require isochronous Ethernet communication. Its extra-low-voltage-range helps provide simple connectivity in real time in different fieldbus environments.

The servo drives are independent cabinet and field components, and about 30% smaller than its predecessor series. The core kinematic component is a brushless servo motor in a 400 mm stainless steel housing with a maximum torque of about 1 Nm. An absolute single-turn encoder with 12-bit resolution is standard.



The CDS can represent and execute complex motion sequences as motion tasks. It supports autonomous positioning with definable trajectories and motion block tables. It offers short cycle times, and highly dynamic motion control tasks can be solved directly in the application.

## >> Category 6A Cable

Encompass™ Product Partner **Belden's** DataTuff Cat 6A cable offers reliable data transfer in extreme environments where cable might be exposed to hazards such as oil, UV and EMI noise interference. It features robust protection, greater bandwidth capacity, a wider frequency range and more PoE.

A unique bonded-pair construction provides consistent performance in a variety of installation conditions. With Type 3 and Type 4 PoE up to 100W, data transfer rates of up to 10Gb/s over 100m and an extended frequency range of 500MHz, these cables suit harsh environments that require high throughput, speed and reliability.

Engineers and system integrators can choose among shielded, unshielded and extreme temperature cable options, depending on the industrial setting where they are applied. The bonded pair construction gives unshielded cables higher noise protection than a regular foil-shielded cable.

The cables are suitable for many industrial markets, including oil and gas, discrete manufacturing, machine building, water wastewater, mining, food and beverage, automotive and transportation sectors.



## >> Sine Wave Filter Monitoring

Encompass™ Product Partner **TCI's** latest addition to their connectivity solutions, the KMG with PQconnect sine wave filters, enables users to monitor and track performance using network communications.

Sine wave filters convert the PWM wave form to a near sinusoidal wave form by attenuating the carrier frequency. Without the protection of a sine wave filter, premature equipment failure may occur due to the VFD PWM carrier frequency and the high dV/dt voltage spikes at the motor terminals.

The KMG with PQconnect adds monitoring and connectivity to the sine wave filter, helping to protect the high-value electrical pumping assets from failure. It also enables pumping and VFD process-control adjustments to optimize uptime and prevent power quality issues. Real-time power quality data can be used to monitor and trend for early detection of abnormal conditions. Users can monitor and track their sine wave filter performance using TCI's free proprietary software, PQvision.



## >> PRODUCT SPOTLIGHT

### Studio 5000 Software Updates

Rockwell Automation **Studio 5000® design software** features two key updates. The new Simulation Interface tool transforms how users design, test, validate and commission systems using digital engineering. The tool connects a system's real or virtual controller to advanced simulation and modeling tools. Users can then simulate how products or processes with dynamic properties will behave in production.

The tool uses the Functional Mock-Up Interface standard to facilitate connections to simulation models that also use the standard. It also connects natively to MATLAB Simulink for direct connections between a Logix program and a simulation model.

The Application Code Manager (ACM) tool has been updated to expand on its existing productivity benefits.

A new document template editor can save users time by automatically generating documentation for their projects. Users only need to create a template and placeholders for data, and ACM will then auto-populate the data when a project is completed.



A new import feature can also help users save time and reduce rework. ACM can now import information from the Integrated Architecture® Builder or Architect tools to automatically create a controller's hardware I/O tree. This reduces duplicative work across design tools.



## >> Enhanced HMI Software

Rockwell Automation has updated its **FactoryTalk® View Site Edition (SE), Machine Edition (ME)** and **ViewPoint HMI software**.

FactoryTalk View v.12 gives engineers a modernized design environment with a new look and feel, simplified user experience and improved design efficiency. An updated application explorer allows users to logically organize graphic displays in folders and subfolders, and a new searchable toolbox makes it easy to find and add graphic objects to displays. The design environment user interface now matches that of Studio 5000 Logix Designer®.



The SE version improves the operator experience, with expanded data access and enriched graphic displays. A new SQL database connector and data grid object provide information for making production decisions. Automatic diagnostics give operators access to device diagnostics provided by the Logix controller. Displays created with scalable vector graphics (SVG) provide a better visual

representation of the system. A new redundant server license reduces costs for users implementing a redundant HMI system. It also supports data grid object, automatic diagnostics and OSI PI data trending.

FactoryTalk View ME now includes an XY plot, showing a machine's actual axis position against its planned route. Enhancements to recipe audit functionality allow users to track recipe value changes to meet data integrity requirements.

## >> Process Solution Integrated with Edge Technology

Encompass™ Product Partner **Stratus Technologies'** "Solution in a Box" process control architecture provides fast, easy deployment at edge locations that require 2,000 I/Os or less.

The solution runs Rockwell Automation PlantPAx® 5.0 software on Stratus zIC Edge. The performance tested, characterized and validated system ensures reliable, rapid deployment by operations teams and systems integrators using a single industrial-grade, panel-mounted Edge Computing device.



The combined architecture provides a flexible approach to scale Industry 4.0 capabilities across a range of environments that was not previously possible.

PlantPAx distributed control system (DCS) uses a common automation platform to seamlessly integrate both process and discrete control as well as plant-wide information.

zIC Edge is an industrial-grade Edge Computing platform that offers built-in redundancy to eliminate unplanned downtime and meets Class 1 Division 2 requirements to operate in hazardous environments.

Based on the joint Stratus and Rockwell Automation characterization, the solution supports environments up to 2,000 I/O points, 5 redundant Logix controllers, 10 clients and 5,000 historian tags.

## >> PRODUCT SPOTLIGHT

### Plant-Wide Performance Audit Offering

Encompass™ Product Partner **Control Station** and Rockwell Automation Solution Partner **JMP Solutions (JMP)** introduce a performance audit offering that facilitates plant-wide process optimization.

The PlantESP™ process analytic and optimization platform from Control Station proactively identifies and isolates control loop performance issues. It uses a production facility's existing process data to uncover a range of mechanical, PID tuning, and process interaction issues that undermine plant profitability.

PlantESP uses the process data stored in FactoryTalk® Historian or other industrial historian solutions. Its analytic capabilities provide insights that allow production staff to focus their energies on addressing the root cause of common PID control-loop performance issues. The PID controller remains the dominant technology for regulating industrial production processes.

The audit offering combines PlantESP's analytic capabilities with JMP's expert process engineering and project management team. JMP completes each audit in under 30 days; its report includes detailed findings and recommendations for process optimization. Control Station and JMP then collaborate with users to build an optimization plan that is customized for their unique business needs.



## >> Globally Certified Enclosures

Encompass™ Product Partner **Pepperl+Fuchs** now offers globally certified enclosures and stocks several standardized sizes of explosion-proof ATEX, IECEx, and North American certified EJB and EJBX enclosures.

The Class I, Division 1 and Zone 1 enclosures are suitable for Groups B, C and D / IIB+H2 with Type 4, 4X, 7, 9, Ex d and IP66/67 ratings. They feature stainless-steel mounting and hinged hardware options, and are available in several sizes with optional windows. With Pepperl+Fuchs' new 4X overpressure testing certification, empty enclosures can be purchased to tap and drill in the field.



Enclosures are manufactured from high-quality stainless steel or copper-free aluminum with increased corrosion resistance. Their durability and design meet the requirements of many industries, including offshore

and marine applications. Corresponding degrees of protection and ambient temperature ranges support long-term durability and safe operation. The enclosures are typically suitable for temperatures from -25°C to +60°C (-50°C for ATEX/IECEx). They can be rated for temperatures as high as +120°C.

## >> Laminated Bus Bars for High Temperature Applications

Encompass™ Product Partner **Mersen** introduces MHi-T high temperature bus bars. Using a combination of polyaramid dielectric insulation and high temperature adhesive, the bus bars respond to increased temperature rises in wide band gap (WBG) technology systems. The bus bars also allow for increased working temperatures up to 180°C.



WBG technologies such as SiC- and GaN-based power modules help increase power densities in their drives and inverters designs. WBG modules introduce an increased level of heat into their laminated bus bars connectors. Increased temperature rises on standard laminated bus bars may cause partial or complete breakdown of the insulation's bonding agent, causing the insulation

to lift and separate from the conductor surface, creating potential unsafe shock or short circuit faults. MHi-T laminated bus bars address this increased temperature rise in WBG power modules with higher temperature tolerances.

# Strain gage input for Point I/O™

- ▶ Two channels per module.
- ▶ 24-bit analog-to-digital conversion.
- ▶ Resolution of 1 count per 100,000 counts.
- ▶ Built-in averaging.
- ▶ Compatible with all industry load cells and weigh scales.



**Helm Instrument Company, Inc.**  
361 West Dussel Drive  
Maumee, OH 43537  
P: 419.893.4356 F: 419.893.1371  
E: Sales@helminstrument.com www.helminstrument.com



FREE EXCLUSIVE CONTENT FROM

# THE JOURNAL



You're just 1 click away from getting free online articles from *The Journal*. Just go to <http://rok.auto/thejournal-subscribe>. Check "The Journal" box to get your free e-newsletter that brings you the digital edition of *The Journal* every issue – plus additional Web-exclusive how-to articles, case studies and product news from Rockwell Automation and companies in its PartnerNetwork™.

Visit [HTTP://ROK.AUTO/THEJOURNAL-SUBSCRIBE](http://rok.auto/thejournal-subscribe)

**SIGN UP TODAY!**

## >> CIP Safety over EtherNet/IP+Modbus TCP Gateway

Encompass™ Product Partner **Bihl+Wiedemann** has added the ASi-5/ASi-3 CIP Safety™ over EtherNet/IP+Modbus™ TCP Gateway (BWU3857). It can transmit larger amounts of data significantly faster and integrate intelligent devices in a simple way. It allows integration of the 2-wire safety network ASi Safety at Work into a PLC with a safety controller. This integration allows the user to save time during commissioning and maintenance.



The gateway fits complex applications, such as large, distributed systems with different safety networks and many safe signals or applications where the safety configuration includes numerous standard signals. Safe input modules are read via CIP Safety and safe output modules can switch via CIP Safety. Moreover, safe ASi outputs are supported in both ASi networks.

The gateway features two ASi-5 masters and two ASi-3 masters; it can communicate as an ASi-5 master and an ASi-3 master simultaneously in two ASi networks. It's equipped with three 2-channel safe inputs and six safe outputs, with an onboard webserver for simple diagnostics and remote maintenance and with an OPC UA server for incorporation into Industry 4.0 applications.

## >> Modbus TCP Communication Module for MCCs

Many companies working within oil and gas and other heavy industries face the challenge of integrating motor control centers (MCCs) into existing distributed control systems (DCSs) that use Modbus™ TCP as the communication protocol. Often, because the DCS does not support EtherNet/IP™, additional hardware and integration effort is needed to complete the system.



A new communication module developed by Rockwell Automation and Encompass™ Product Partner **HMS Networks** addresses this challenge by improving CENTERLINE® 2100 and CENTERLINE 2500 MCC integration onto Modbus TCP networks. The module provides a complete integration solution, acting as a native device on Modbus TCP/IP control systems. It serves as the single integration product for all the smart devices within an MCC, reducing hardware costs.

In addition to helping to alleviate start-up efforts and costs, the Modbus TCP communication module also makes maintenance easier. Once integrated into the control system, users have access to power, energy and maintenance data to make informed decisions about their equipment.

## >> PRODUCT SPOTLIGHT

### Asset Health Monitoring Solution

Rockwell Automation Strategic Alliance Partner **Endress+Hauser** offers its SRP700 system-ready package based on the FieldCare device configuration application and combines it with new Health Monitoring Application software.

The pre-engineered software is designed for Rockwell Automation systems and tailored for various industries. The solution accesses field instrumentation diagnostics and presents it in easily readable format to plant personnel, improving transparency, reducing maintenance costs and increasing plant availability.

The SRP700 runs on traditional hardware or in a virtual machine environment and is comprised of a central monitor and gateway, a standard client for device configuration management and mobile client, and the Field Xpert SMT70 IP65/Class 1 Div 2 industrial tablet. It is used to access and acquire data from a variety of field devices, primarily analyzers and instruments. An optional KPI dashboard presents diagnostics, history, statistics, and other information in an easily readable format.

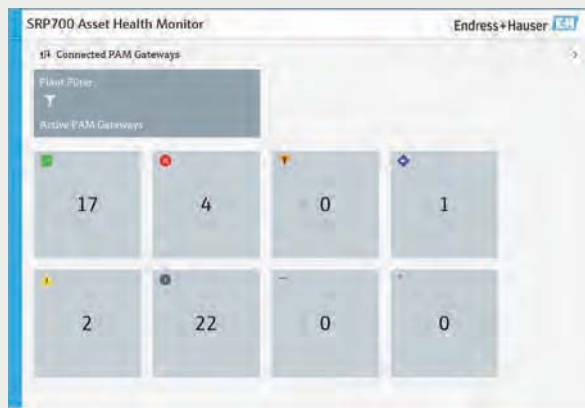

Plant personnel can use the SRP700 to take actions on diagnostic data provided by devices; connect to devices for troubleshooting and configuration; see actual and past diagnostic data with corrective measures related with time stamps; and analyze historical device diagnostic data.

The solution uses Rockwell Automation PAC and HART I/O infrastructure to directly monitor diagnostics from Endress+Hauser and third-party field process instruments.



## >> PLC Module for Cloud Communication

Encompass™ Product Partner **Softing Inc.**'s **iManager** for AWS IoT SiteWise delivers streamlined connectivity between Rockwell Automation PLCs and AWS IoT SiteWise cloud computing services for industrial analytics at scale.

The **iManager ControlLogix™** or **CompactLogix™** PLC module inserts into the PLC chassis and enables direct and secure transactions between the PLC and cloud with no server, no coding and no protocol translation needed. Connecting **iManager** directly into the AWS IoT Core simplifies the processes to connect the plant floor for analytics, dashboards and business results.

Users can use AWS IoT SiteWise to model physical assets, processes and facilities; quickly compute common industrial performance metrics; create fully managed web applications to help analyze industrial equipment data; reduce costs and make faster decisions. Users also can focus on understanding and optimizing operations, rather than building costly in-house data

collection and management applications.

Easy connectivity includes drop down box selections for AWS cloud type and certificate entry. Auto pre-formatted data further simplifies connectivity, adds security, saves time, and reduces opportunities for errors.



## >> Adapter Grommets

Encompass™ Product Partner **icotek** expanded its range of adapter grommets for its IMAS-CONNECT adapter system to include the AT-PP and the AT-K-M. The AT-PP adapter grommet is based on a KT large cable grommet. A polyamide body is integrated in this elastomer grommet.

Screw-on housing allows all compact Push Pull module systems to be routed into the grommet.

Using the IP65-rated AT-PP adapter grommet, pre-assembled cables and Push Pull termination points can be routed through the same knock-out. This reduces the need for multiple knock-outs, cutting labor time, costs and space.

The AT-K-M adapter grommet is based on a KT small cable grommet. A nickel-plated brass body is integrated in this grommet. It is available with internal threads M5 x 0.5, M8 x 1.0, M12 x 1.0, M12 x 1.5, M14 x 1.0 and M16 x 1.5.

Pneumatic bulkhead plug connections, numerous round plug connectors and pressure compensation elements integrate directly into the cable entry using the AT-K-M adapter grommet. It is compatible with all icotek cable entry systems where KT grommets can be used.

The AT-K-M has a protection class up to IP66 depending on the type of cable entry used.



## >> PRODUCT SPOTLIGHT

### PlantPax 5.0

The Rockwell Automation **PlantPax® 5.0 distributed control system (DCS)** features new capabilities that introduce process functionality native to the controller, modernizing the DCS with a reduced footprint, project consistency, streamlined workflows, TÜV Certification for cybersecurity and analytics.

New process controllers advance processing power and capacity to reduce the complexity of PlantPax architectures. This reduces the system's total cost of ownership throughout the life cycle.

With native process instructions embedded in the controller firmware, project teams can adopt control strategies that drive consistency for individual projects or multi-site deployments. Consistency simplifies the life cycle management of deployed systems as teams modernize their automation infrastructure.

Development teams will realize savings in the configuration of instrumentation, alarms and diagnostic system elements. Operators will have the extended ability to view underlying control logic in a safe and secured manner. Maintenance will have controlled view access for troubleshooting.



The system architectures are TÜV certified to the international standard ISA-99/IEC 62443-3-3, which provides guidance on the implementation of an electronically secured system.

Purpose-built frameworks easily connect live and historical data from the DCS into reporting and analytical tools. The system also supports extended experiences, such as augmented reality. Scalable analytic packages leverage predictive and prescriptive models for process applications such as soft sensors, anomaly detection or model predictive control.

## ADVERTISERS INDEX

Advanced Micro Controls, Inc. (AMCI)	35
Apex Dynamics Inc.	6
Ametek	30
Endress+Hauser, Inc.	3
Hardy Process Solutions	35
Helm Instrument Co. Inc.	39
HMS Networks	24, 35
MAVERICK Technologies, a Rockwell Automation Company	44
MTS Systems Corp., Sensors Division	11
RACO Manufacturing & Engineering Co.	35
Rockwell Automation Control System Migration	43
Rockwell Automation MicroLogix 1400 Controller	13
Rockwell Automation PowerFlex 755TL Drives	25
Spectrum Controls, Inc.	2
Stratus Technologies	35
Sytech Inc.	35

### >> Mobile Hand-Held Printers

Encompass™ Product Partner **Panduit** has launched two new mobile printers, the MP100 and MP300, in partnership with Epson.

The printers feature fast 1.4-in./sec. print speed, a variety of die-cut and continuous label sizes and materials, USB connectivity and an integrated automatic cutter with full and half cutting. Users can print directly using Easy-Mark Plus software and print on up to 1.5-in.-wide label media.

The product features and corresponding label cassettes were designed to meet the needs of challenging applications from the data center to the plant floor.



## ENJOY *THE JOURNAL'S* PODCAST, “AUTOMATION CHAT”

Join Theresa Houck, Executive Editor of *The Journal From Rockwell Automation and Our PartnerNetwork* magazine, for our “Automation Chat” podcast.

Enjoy short, informative and fun conversations with industrial automation pros about technology, digital transformation, industry trends, workforce challenges and more.

Available on your favorite podcast app, or listen here: <https://rokthejournal.podbean.com>.



**LISTEN NOW!**

# Migration is easy when you have the **right tools** and **support**



What if you can achieve better system performance, increased capacity, improved productivity, and enhanced security to meet the growing demands of smart manufacturing?

Our **SLC™ 500 to CompactLogix™ 5380 control system migration** is the right option for you. And, we can help you along your migration journey with the

- ▶ **Right plan:**  
Modernization and conversion services to help you strategize
- ▶ **Right tool:**  
Easy-to-install 1492 I/O wiring and conversion system to reduce I/O wiring time and effort
- ▶ **Right product:**  
CompactLogix 5380 and Compact GuardLogix® 5380 controllers and Compact 5000™ I/O

Take your next step to meet more application requirements in multiple industries with the modern technology options of CompactLogix 5380 standard and safety control systems.

Step forward to [rok.auto/slctocompactlogix](http://rok.auto/slctocompactlogix)

Copyright © 2020 Rockwell Automation, Inc. All Rights Reserved.

 **Allen-Bradley**  
by ROCKWELL AUTOMATION



# HOW WELL DOES YOUR HMI HANDLE ALARM FLOODS?

**The right Alarm Management partner will save you money and reduce your risk.**

MAVERICK has 400+ professionals with deep knowledge of your industry, resources available 24/7/365 out of 21 locations across the U.S.

We combine industry experience and software to apply the latest alarm management principles.

We empower your operators to respond safely and effectively.



A typical plant loses more than 5% of its total capacity every year due to poor alarm response.

**MAVERICK**<sup>™</sup>  
TECHNOLOGIES

A Rockwell Automation Company

Take control of your operations and choose to partner with MAVERICK Technologies for safe and effective alarm management.

[mavtechglobal.com](http://mavtechglobal.com) | 888.917.9109