

Owner's Manual & Safety Instructions

Save This Manual Keep this manual for the safety warnings and precautions, assembly, operating, inspection, maintenance and cleaning procedures. Write the product's serial number in the back of the manual near the assembly diagram (or month and year of purchase if product has no number). Keep this manual and the receipt in a safe and dry place for future reference.

19h

VULCAN®

OMNIPRO 220 MULTIPROCESS WELDING SYSTEM



Visit our website at: <http://www.harborfreight.com>
Email our technical support at: productsupport@harborfreight.com

63621

When unpacking, make sure that the product is intact and undamaged. If any parts are missing or broken, please call 1-888-866-5797 as soon as possible.

Copyright© 2017 by Harbor Freight Tools®. All rights reserved.
No portion of this manual or any artwork contained herein may be reproduced in any shape or form without the express written consent of Harbor Freight Tools. Diagrams within this manual may not be drawn proportionally. Due to continuing improvements, actual product may differ slightly from the product described herein. Tools required for assembly and service may not be included.





⚠ WARNING

Read this material before using this product. Failure to do so can result in serious injury. SAVE THIS MANUAL.

Table of Contents

Safety2	Welding Tips34
Specifications7	Maintenance41
Controls8	Parts List and Diagram46
MIG/Flux-Cored Wire Welding10	Warranty48
TIG/Stick Welding24	

WARNING SYMBOLS AND DEFINITIONS

	This is the Safety alert symbol. It is used to alert you to potential personal injury hazards. Obey all Safety messages that follow this symbol to avoid possible injury or death.
	Indicates a hazardous situation which, if not avoided, will result in death or serious injury.
	Indicates a hazardous situation which, if not avoided, could result in death or serious injury.
	Indicates a hazardous situation which, if not avoided, could result in minor or moderate injury.
	Addresses practices not related to personal injury.

IMPORTANT SAFETY INFORMATION

WARNING

Read all Safety warnings and instructions.
 Failure to follow the warnings and instructions may result in electric shock, fire and/or serious injury.
 Save all warnings and instructions for future reference.

General Safety

PROTECT yourself and others. Read and understand this information.

1. **Before use, read and understand manufacturer's instructions, Material Safety Data Sheets (MSDS's), employer's Safety practices, and ANSI Z49.1.**
2. **Keep out of reach of children.**
Keep children and bystanders away while operating.
3. **Place the welder on a stable location before use.**
If it falls while plugged in, severe injury, electric shock, or fire may result.
4. **Do not overreach.**
Keep proper footing and balance at all times.
5. **Stay alert, watch what you are doing and use common sense when operating a welder. Do not use a welder while you are tired or under the influence of drugs, alcohol or medication.**
A moment of inattention while operating welders may result in serious personal injury.
6. **Avoid unintentional starting.** Make sure you are prepared to begin work before turning on the Welder.
7. **Never leave the Welder unattended while energized.** Turn power off if you have to leave.
8. **The warnings, precautions, and instructions discussed in this instruction manual cannot cover all possible conditions and situations that may occur.** It must be understood by the operator that common sense and caution are factors which cannot be built into this product, but must be supplied by the operator.

Fume and Gas Safety



INHALATION HAZARD: Welding and Plasma Cutting produce toxic fumes.

- Exposure to welding or cutting exhaust fumes can increase the risk of developing certain cancers, such as cancer of the larynx and lung cancer.** Also, some diseases that may be linked to exposure to welding or plasma cutting exhaust fumes are:
 - Early onset of Parkinson's Disease
 - Heart disease
 - Ulcers
 - Damage to the reproductive organs
 - Inflammation of the small intestine or stomach
 - Kidney damage
 - Respiratory diseases such as emphysema, bronchitis, or pneumoniaUse natural or forced air ventilation and wear a respirator approved by NIOSH to protect against the fumes produced to reduce the risk of developing the above illnesses.
- Do not use near degreasing or painting operations.**
- Keep head out of fumes.**
Do not breathe exhaust fumes.
- Use enough ventilation, exhaust at arc, or both, to keep fumes and gases from breathing zone and general area.** If engineering controls are not feasible, use an approved respirator.
- Work in a confined area only if it is well-ventilated, or while wearing an air-supplied respirator.**
- Have a recognized specialist in Industrial Hygiene or Environmental Services check the operation and air quality and make recommendations for the specific welding situation.**
Follow OSHA guidelines for Permissible Exposure Limits (PEL's) and the American Conference of Governmental Industrial Hygienists recommendations for Threshold Limit Values (TLV's) for fumes and gases.

SAFETY

CONTROLS

WIRE

Arc Ray Safety



ARC RAYS can injure eyes and burn skin.

- Wear ANSI-approved welding eye protection featuring at least a number 10 shade lens rating.**
- Wear leather leggings, fire resistant shoes or boots during use.** Do not wear pants with cuffs, shirts with open pockets, or any clothing that can catch and hold molten metal or sparks.
- Keep clothing free of grease, oil, solvents, or any flammable substances.**
Wear dry, insulating gloves and protective clothing.
- Wear an approved head covering to protect the head and neck.** Use aprons, cape, sleeves, shoulder covers, and bibs designed and approved for welding and cutting procedures.
- Wear an approved welding jacket or long sleeves to protect forearms from radiation burns.**
- When welding/cutting overhead or in confined spaces, wear flame resistant ear plugs or ear muffs to keep sparks out of ears.**

TIG / STICK

WELDING TIPS

MAINTENANCE

Electrical Safety



ELECTRIC SHOCK can KILL.

1. **Turn off, disconnect power, and discharge electrode to ground before setting down torch/electrode holder and before service.**
2. **Do not touch energized electrical parts.** Wear dry, insulating gloves. Do not touch electrode holder, electrode, welding torch, or welding wire with bare hand. Do not wear wet or damaged gloves.
3. **Connect to grounded, GFCI-protected power supply only.**
4. **Do not use near water or damp objects.**
5. **People with pacemakers should consult their physician(s) before use.** Electromagnetic fields in close proximity to heart pacemaker could cause pacemaker interference or pacemaker failure.
6. **Do not expose welders to rain or wet conditions.** Water entering a welder will increase the risk of electric shock.
7. **Do not abuse the cord. Never use the cord for carrying, pulling or unplugging the welder. Keep cord away from heat, oil, sharp edges or moving parts. Damaged or entangled cords increase the risk of electric shock.**
8. **Do not use outdoors.**
9. **Insulate yourself from the workpiece and ground.** Use nonflammable, dry insulating material if possible, or use dry rubber mats, dry wood or plywood, or other dry insulating material large enough to cover your full area of contact with the work or ground.
10. **THIS WELDING MACHINE MUST BE CONNECTED TO POWER SOURCE IN ACCORDANCE WITH APPLICABLE ELECTRICAL CODES.**

SAFETY

CONTROLS

WIRE

Fire Safety



ARC AND SLAG can cause fire.

1. **Clear away or protect flammable objects.** Remove or make safe all combustible materials for a radius of 35 feet (10 meters) around the work area. Use a fire resistant material to cover or block all open doorways, windows, cracks, and other openings.
2. **Keep ABC-type fire extinguisher near work area and know how to use it.**
3. **Maintain a safe working environment.** Keep the work area well lit. Make sure there is adequate surrounding workspace. Keep the work area free of obstructions, grease, oil, trash, and other debris.
4. **Do not operate welders in atmospheres containing dangerously reactive or flammable liquids, gases, vapors, or dust.** Provide adequate ventilation in work areas to prevent accumulation of such substances. *Welders create sparks which may ignite flammable substances or make reactive fumes toxic.*
5. **If working on a metal wall, ceiling, etc., prevent ignition of combustibles on the other side by moving the combustibles to a safe location.** If relocation of combustibles is not possible, designate someone to serve as a fire watch, equipped with a fire extinguisher, during the cutting process and for at least one half hour after the cutting is completed.
6. **Do not weld or cut on materials having a combustible coating or combustible internal structure, as in walls or ceilings, without an approved method for eliminating the hazard.**
7. **Do not dispose of hot slag in containers holding combustible materials.**
8. **After welding, make a thorough examination for evidence of fire.** Be aware that easily visible smoke or flame may not be present for some time after the fire has started.
9. **Do not apply heat to a container that has held an unknown substance or a combustible material whose contents, when heated, can produce flammable or explosive vapors.** Clean and purge containers before applying heat. Vent closed containers, including castings, before preheating, welding, or cutting.

TIG / STICK

WELDING TIPS

MAINTENANCE

Welder Use and Care

1. **Do not use the welder if the switch does not turn it on and off.** *Any welder that cannot be controlled with the switch is dangerous and must be repaired.*
2. **Disconnect the plug from the power source before making any adjustments, changing accessories, or storing welders.** *Such preventive Safety measures reduce the risk of starting the welder accidentally.*
3. **Prevent unintentional starting. Ensure the switch is in the off-position before connecting to power source or moving the welder.** *Carrying or energizing welders that have the switch on invites accidents.*
4. **Store idle welders out of the reach of children and do not allow persons unfamiliar with the welder or these instructions to operate the welder.** Welders are dangerous in the hands of untrained users.
5. **Use the welder and accessories in accordance with these instructions, taking into account the working conditions and the work to be performed.** *Use of the welder for operations different from those intended could result in a hazardous situation.*
6. **Do not use the welder for pipe thawing.**

Maintenance

1. **Maintain welders. Check for misalignment or binding of moving parts, breakage of parts and any other condition that may affect the welder's operation. If damaged, have the welder repaired before use.** *Many accidents are caused by poorly maintained welders.*
2. **Have your welder serviced by a qualified repair person using only identical replacement parts.** *This will ensure that the Safety of the welder is maintained.*
3. **Maintain labels and nameplates on the Welder.** These carry important information. If unreadable or missing, contact Harbor Freight Tools for a replacement.
4. **Unplug before maintenance.** Unplug the Welder from its electrical outlet before any inspection, maintenance, or cleaning procedures.

Gas Shielded Welding - Cylinder Safety

Cylinders can explode when damaged.



1. **Do not weld on a pressurized or closed cylinder.**
2. **Do not allow an electrode holder, electrode, welding torch, or welding wire to touch the cylinder.**
3. **Keep cylinders away from any electrical circuits, including welding circuits.**
4. **Keep protective cap in place over the valve except when the cylinder is in use.**
5. **Use only correct gas shielding equipment designed specifically for the type of welding you will do.** Maintain this equipment properly.
6. **Protect gas cylinders from heat, being struck, physical damage, slag, flames, sparks, and arcs.**
7. **Use proper procedures to move cylinders.**



SAVE THESE INSTRUCTIONS.

Grounding

⚠ WARNING



TO PREVENT ELECTRIC SHOCK AND DEATH FROM INCORRECT GROUNDING WIRE CONNECTION:

Check with a qualified electrician if you are in doubt as to whether the outlet is properly grounded. Do not use the welder if the power cord or plug is damaged. If damaged, have it repaired by a service facility before use. If the plug will not fit the outlet, have a proper outlet installed by a qualified electrician, do not use adapter plugs.

1. The green wire inside the cord is connected to the grounding system in the Welder. The green wire in the cord must be the only wire connected to the Welder's grounding system and must never be attached to an electrically "live" terminal. Never leave the grounding wire disconnected or modify either Power Cord Plug in any way.
2. Make sure the tool is connected to an outlet having the same configuration as the plug. If the tool must be reconnected for use on a different type of electric circuit, the reconnection should be made by qualified service personnel; and after reconnection, the tool should comply with all local codes and ordinances.







Extension Cords







Do not use an extension cord on this welder.

Replacement Cords

1. Use only one of the supplied power cords for this welder or an identical replacement cord.
2. Do not install a thinner or longer cord on this welder.
3. Do not patch cords of any length together for this item, patches may allow moisture to penetrate the insulation, resulting in electric shock.

Symbology

	Wire Feed (Speed)
	Workpiece Ground Cable
	Torch Cable
	Overheat Shutdown Indicator
	Cooling Fan
	Housing Ground Point
VAC	Volts Alternating Current
A	Amperes
OCV	Open Circuit Voltage
KVA	Kilovolt Amperes (Volts / 1000 * Amperes)

IPM	Inches Per Minute
AWG	American Wire Gauge
	Electric Shock Hazard. Do not touch energized parts.
	Inhalation Hazard. Keep head out of fumes and use proper ventilation.
	Read manual before setup and/or use.
	Fire Hazard. Keep flammable materials away during welding. Spatter can cause accidental fires.
	Arc Ray Hazard. Wear welding helmet with properly rated filter lens.
	Pacemaker Hazard. Welding processes may interfere with pacemakers. Consult doctor before use.

Specifications

MIG		
Power Input	120VAC / 60Hz	240VAC / 60Hz
Current Input at Output	20.8A at 100A	25.5A at 200A
Welding Current Range	30–140A	30–220A
Rated Duty Cycles	40% @ 100A 100% @ 75A	25% @ 200A 100% @ 115A
Maximum OCV	78VDC	
Weldable Materials	Mild Steel, Stainless Steel Aluminum (with optional Spool Gun)	
Welding Wire Capacity	Solid Core: 0.025"/0.030"/0.035" Flux Cored: 0.030"/0.035"/0.045"	
Wire Speed	50–500 IPM	
Wire Spool Capacity	Up to 12 lb spool	

TIG		
Power Input	120VAC / 60Hz	240VAC / 60Hz
Current Input at Output	20.6A at 125A	15.6A at 175A
Welding Current Range	10A–125A	10A–175A
Rated Duty Cycles	40% @ 125A 100% @ 90A	30% @ 175A 100% @ 105A
Maximum OCV	78VDC	
Weldable Materials	Mild Steel, Stainless Steel, Chrome Moly	

Stick		
Power Input	120VAC / 60Hz	240VAC / 60Hz
Current Input at Output	19.5A at 80A	23.7A at 175A
Welding Current Range	10A–80A	10A–175A
Rated Duty Cycles	40% @ 80A 100% @ 60A	25% @ 175A 100% @ 100A
Maximum OCV	78VDC	
Weldable Materials	Mild Steel, Stainless Steel	

SAFETY

CONTROLS

WIRE

TIG / STICK

WELDING TIPS

MAINTENANCE

Front Panel Controls

SAFETY

CONTROLS

WIRE

TIG / STICK

WELDING TIPS

MAINTENANCE

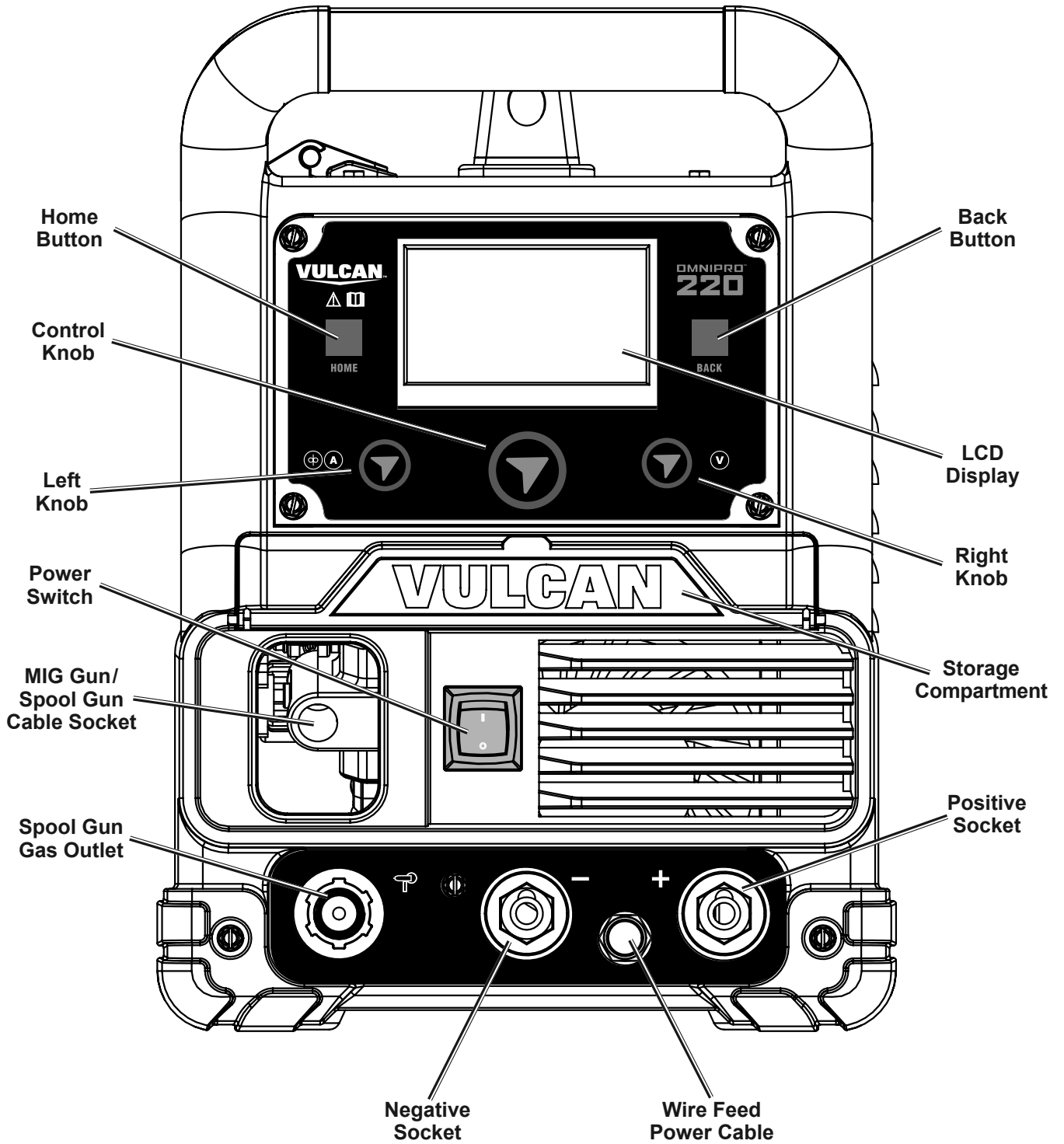

Note: When using an optional Spool Gun (sold separately), connect the Spool Gun gas hose to the Spool Gun Gas Outlet.

Interior Controls

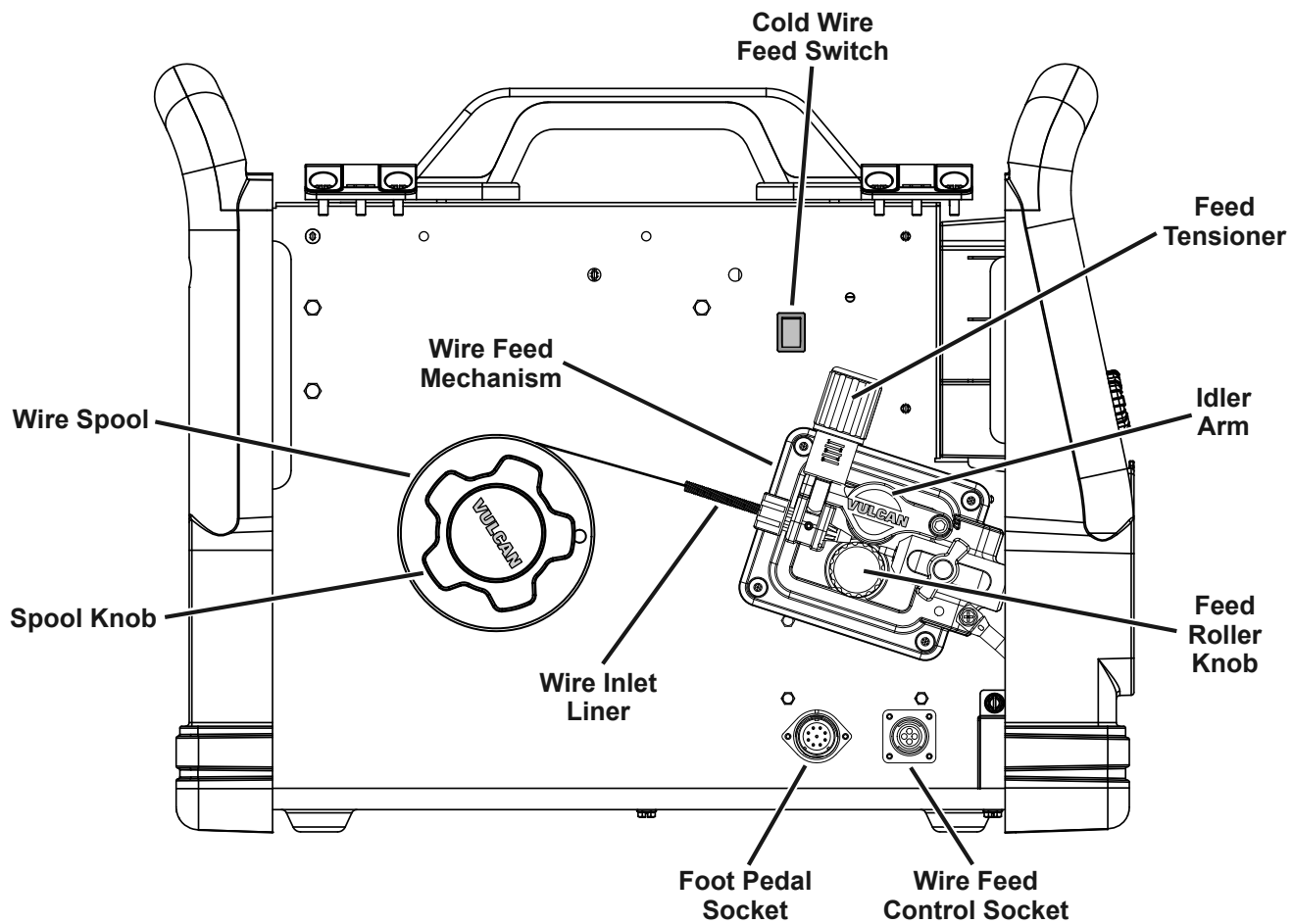

SAFETY

CONTROLS

WIRE

TIG / STICK

WELDING TIPS

MAINTENANCE

MIG/Flux-Cored Wire Welding



Read the **ENTIRE IMPORTANT SAFETY INFORMATION** section at the beginning of this manual including all text under subheadings therein before set up or use of this product.



TO PREVENT SERIOUS INJURY FROM ACCIDENTAL OPERATION:
Turn the Power Switch off and unplug the Welder before setup.

Note: Remove the protective foam and cardboard from the Welder before setup.

Wire Spool Installation/Wire Setup

1. Turn the Power Switch OFF and unplug the Welder before proceeding.

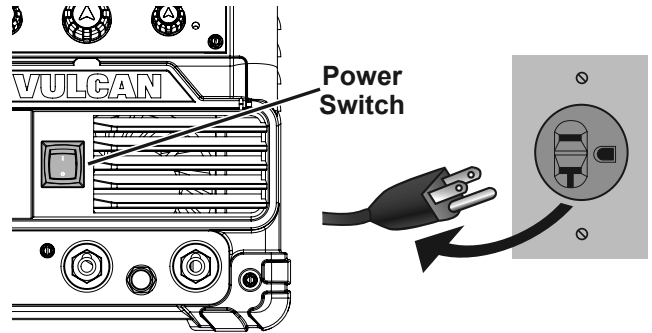

2. Pull up on the Door Latch, then open the Door.

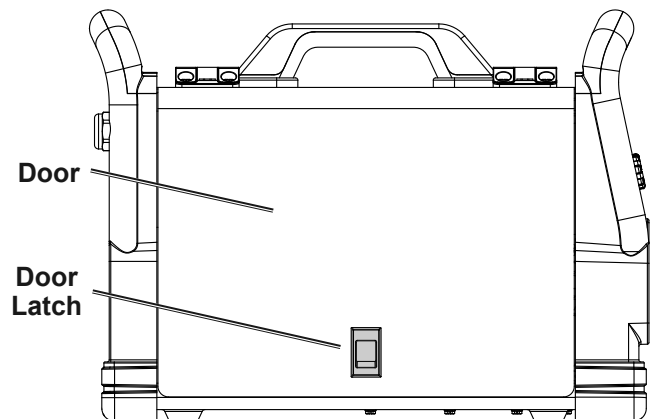

3. **1-2 Pound Wire Spool Installation:** Remove the Wingnut and Spacer. If replacing a Spool, remove the old Spool and all remaining wire from the liners.

4. Place the new Wire Spool over the Spool Spindle and against the Spool Brake Pad as illustrated. **To prevent wire feed problems, set the Spool so that it will unwind clockwise.**

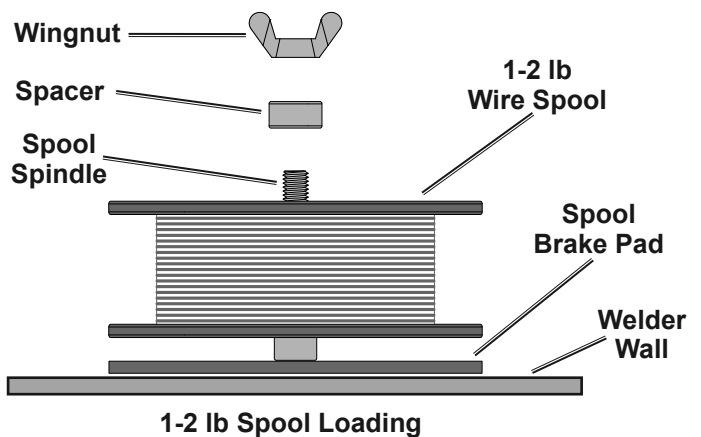

5. Replace the Spacer over the Spool Spindle and secure Spool in place with the Wingnut.

Notice: If Wire Spool can spin freely, Wingnut is too loose. This will cause the welding wire to unravel and unspool which can cause tangling and feeding problems.

6. **10-12 Pound Wire Spool Installation:**

Remove the Wingnut and Spacer. If replacing a Spool, remove the old Spool and all remaining wire from the liners.

7. Place the Spool Adapter over the Spool Spindle and against the Spool Brake Pad as illustrated.

8. Place the new Wire Spool over the Adapter and line up pin on Adapter with hole in Spool. **To prevent wire feed problems, set the Spool so that it will unwind clockwise.**

9. Replace the Spacer over the Spool Spindle and secure Spool in place with the Wingnut.

Notice: If Wire Spool can spin freely, Wingnut is too loose. This will cause the welding wire to unravel and unspool which can cause tangling and feeding problems.

10. Screw the Spool Knob into the Spool Adapter.

11. Turn the Feed Tensioner knob counterclockwise to loosen it enough to pull it down to remove tension. The spring-loaded Idler Arm will move up as shown.

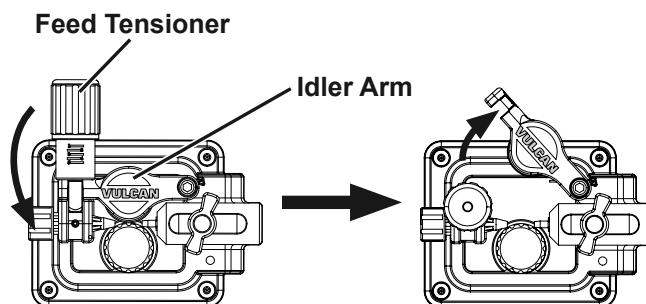
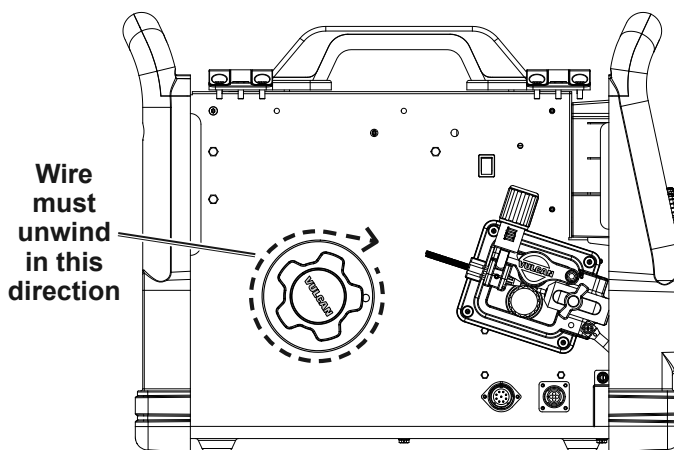
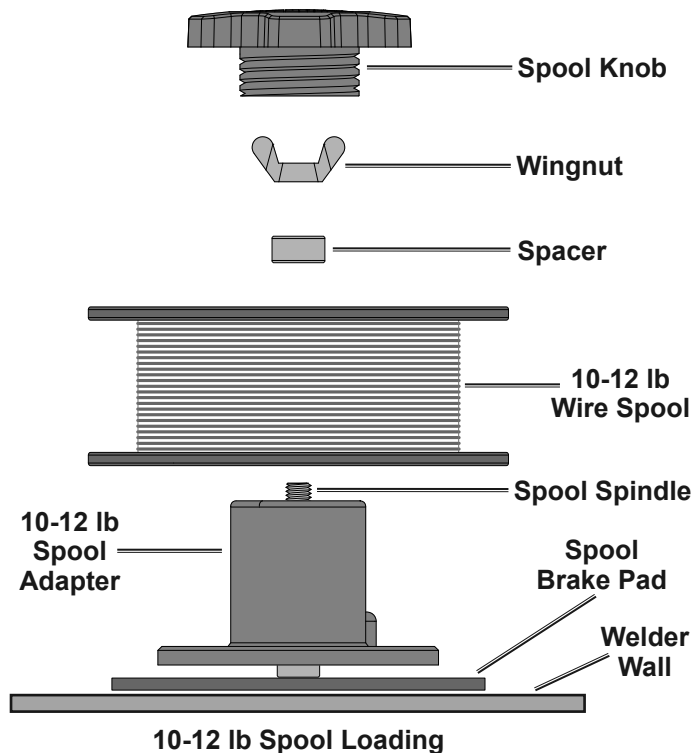

12. **Feed Roller Instructions:**

Check that the Feed Roller is correct for the type of wire being used (solid core or flux-cored) and that it is turned to properly match the wire size marked on the Wire Spool:

- a. Unscrew the Feed Roller Knob counterclockwise.

- b. Remove the Feed Roller Knob to expose the Feed Roller.

- c. Flip or replace the Feed Roller as needed and confirm that it is the correct Roller for the type of wire being used and that **the number showing is the same as the wire diameter on the Spool.**

- d. Screw the Feed Roller Knob back into place to secure the Feed Roller.

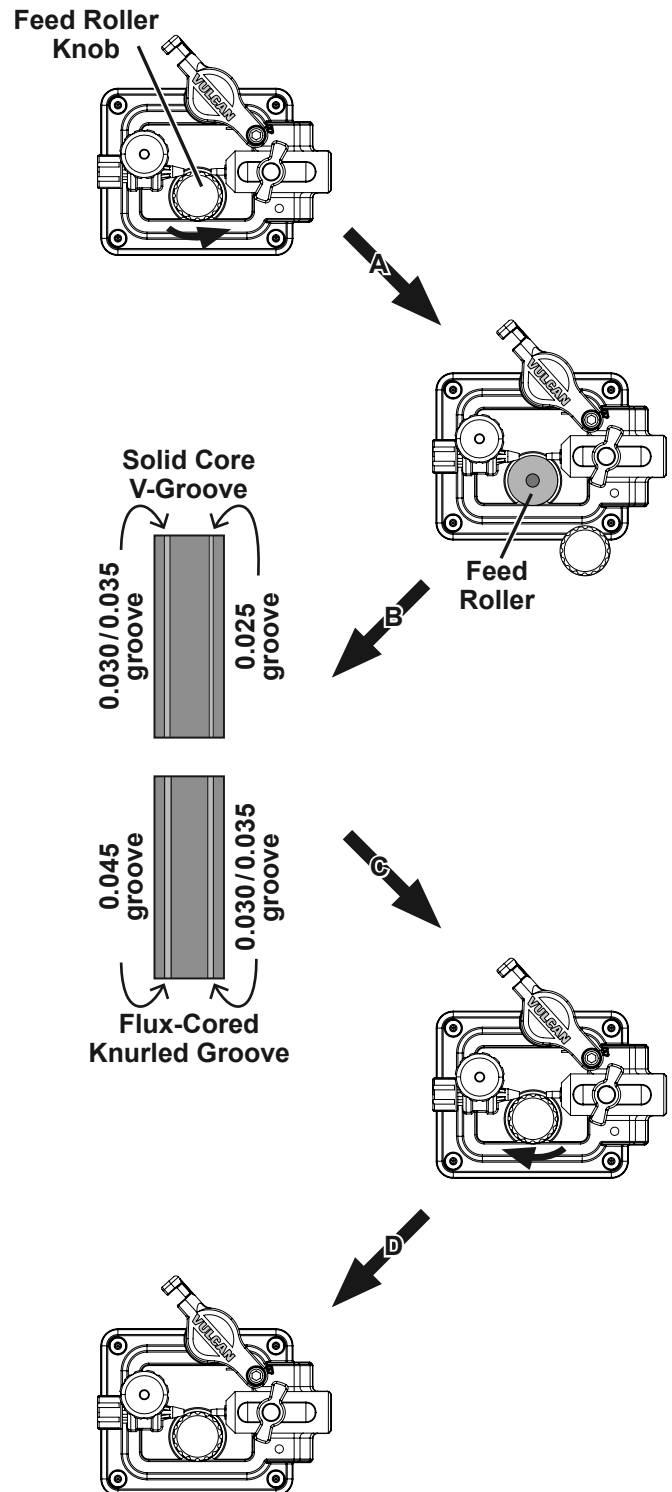

13. Loosen the Knob on the Wire Feed mechanism, then insert the Gun Cable Connector through the hole on the Welder front and into the socket on the Wire Feed.

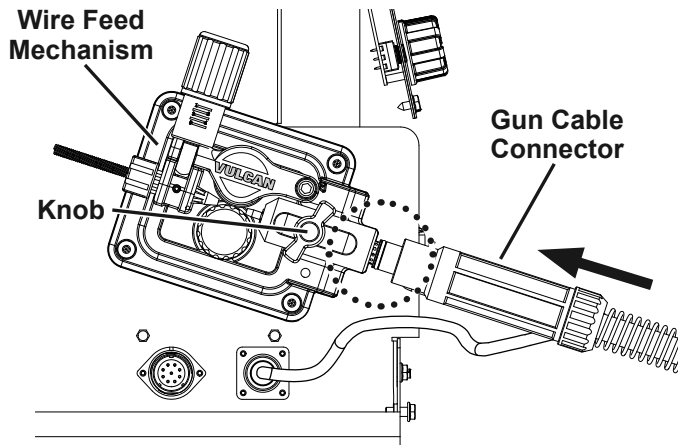

Incorrect—Connector not fully inserted

14. Ensure that the Gun Cable Connector is fully inserted into the socket on the Wire Feed mechanism as shown, then tighten the Knob securely. If Connector is not fully inserted, the gas connection will leak, preventing shielding gas from reaching the welding arc.

NOTICE: To prevent damage, do not overtighten the Knob.

15. Insert the Wire Feed Control Cable through the hole on the Welder front and connect it to the Wire Feed Control Socket inside the machine, then tighten the lock ring on the Cable plug. Note that the plug on the Cable fits into the Socket in one specific orientation only.

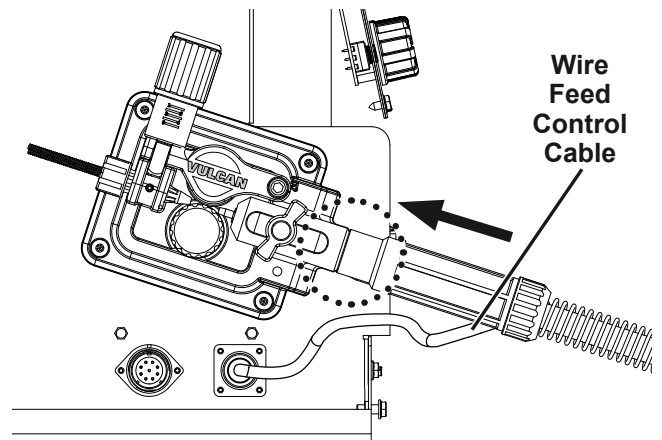

Correct—Connector fully inserted

16. **DCEN Direct Current Electrode Negative Wire Setup for Flux-Cored (gasless) welding:** Plug Ground Clamp Cable into Positive (+) Socket. Plug Wire Feed Power Cable into Negative (-) Socket. Twist cables clockwise all the way to lock in place.

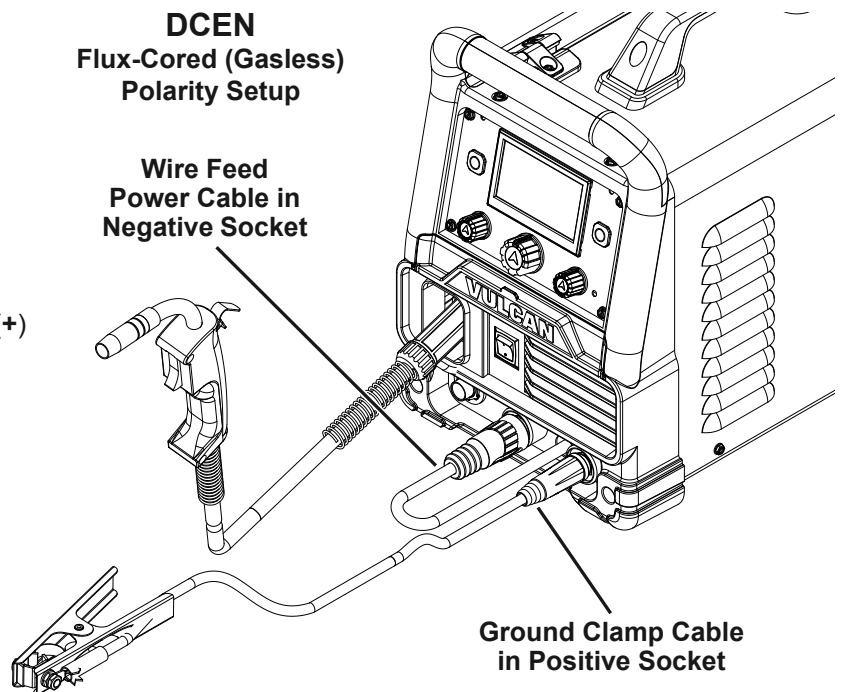

17. **DCEP Direct Current Electrode Positive Wire Setup for Solid Core (gas shielded) welding:**

- Plug Ground Clamp Cable into Negative (-) Socket. Plug Wire Feed Power Cable into Positive (+) Socket. Twist cables clockwise all the way to lock in place.
- Determine which type of shielding gas would be appropriate for the welding you will do. Refer to the Settings Chart on the inside of the Welder door.

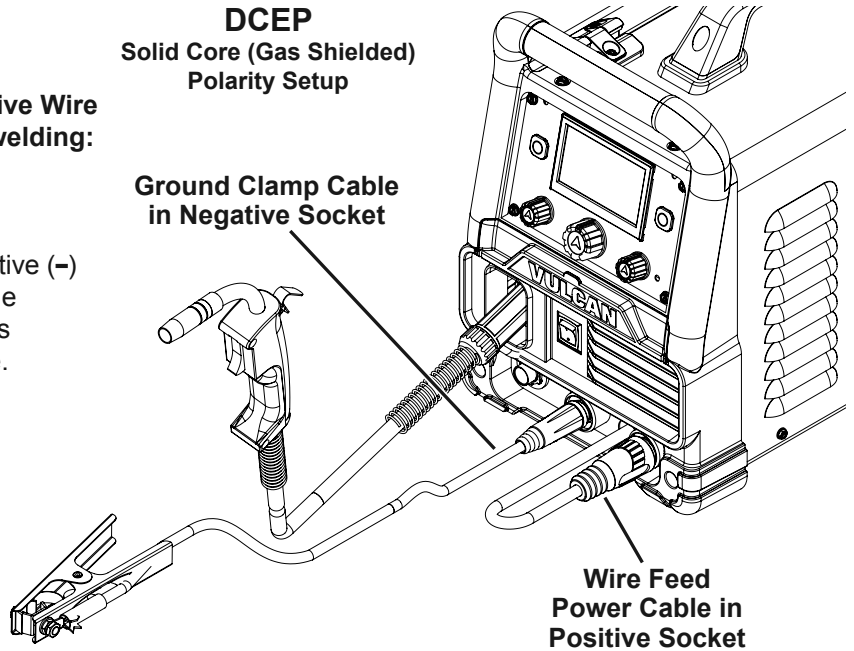

- With assistance, set the cylinder (not included) onto a cabinet or cart near the Welder and secure the cylinder in place with two straps (not included) to prevent tipping.

- Remove the cylinder's cap. Stand to the side of the valve opening, then open the valve briefly to blow dust and dirt from the valve opening. Close the cylinder valve.

- Locate the Regulator (included) and close its valve until it is loose, then thread Regulator onto cylinder and wrench-tighten connection.

Note: When using C100 shielding gas, connect the enclosed CGA 580/320 adapter to the inlet connection of the Regulator and wrench-tighten. Thread the adapter onto the gas cylinder and wrench-tighten.

- Attach the Gas Hose (included) to the Regulator's outlet and the Welder's gas inlet. Wrench-tighten both connections.

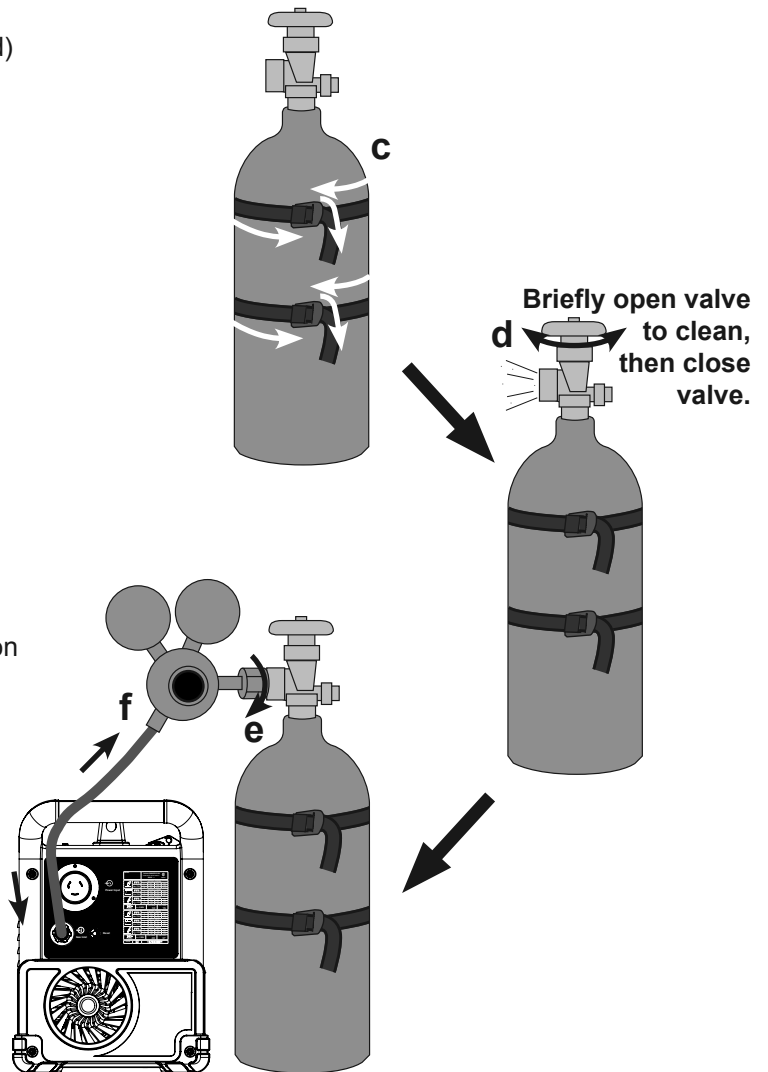

IMPORTANT

Securely hold onto the end of the welding wire and keep tension on it during the following steps.

If this is not done, the welding wire will unravel and unspool which can cause tangling and feeding problems.

18. Cut off all bent and crimped wire. The cut end must have no burrs or sharp edges; cut again if needed.

19. Keep tension on the wire and guide at least 12 inches of wire into the Wire Inlet Liner and Feed Guide.

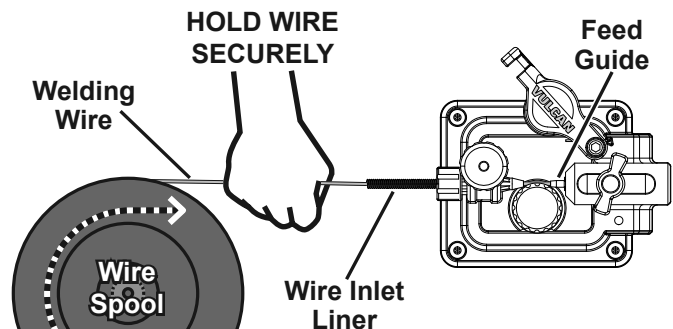

20. Make sure the welding wire is resting in the groove of the Feed Roller, then push the wire Idler Arm down, and swing the Feed Tensioner up to latch it across the tip of the arm. After the wire is held by the Tensioner, you may release it.

Note: The tension should be 3–5 for solid wire and 2–3 for flux-cored wire. Too much force on flux-cored wire will crush it and may cause feeding issues.

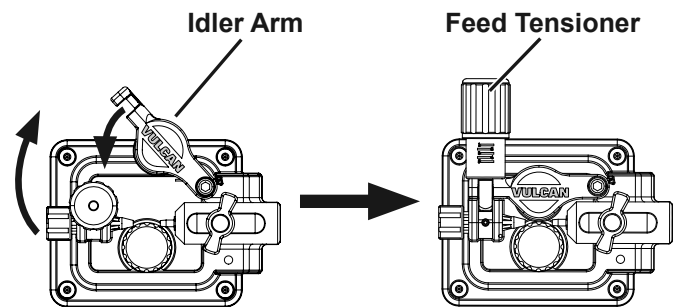

21. Pull the Nozzle to remove it.
22. Unscrew the Contact Tip counterclockwise and remove.
23. Lay the MIG Gun Cable out in a straight line so that the welding wire moves through it easily. Leave the cover open, so that the feed mechanism can be observed.

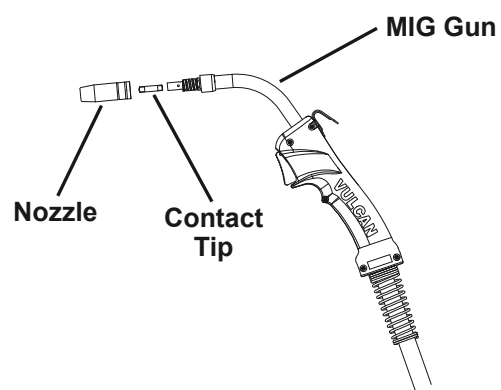

IMPORTANT

Stainless steel wire is less flexible than other welding wire. Therefore, it is more difficult to feed through the liner and gun. It is especially important to keep the gun cable straight while feeding stainless steel wire.

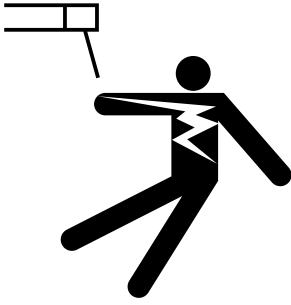
**⚠ DANGER**

**PARTS MAY BE AT WELDING VOLTAGE
TO PREVENT ELECTRIC SHOCK AND DEATH:**

1. Keep hands away from Wire Feed mechanism.
2. Close door before plugging in, unless using Cold Wire Feed to feed wire through to gun.
3. Do not touch Trigger while feeding wire through to gun.

24. Plug either 120VAC or 240VAC Power Cord into Power Input Socket.

Note: Plug will only fit one way.

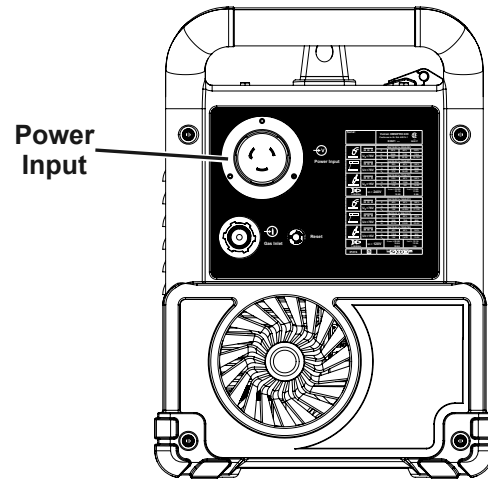

25. Do not touch the Gun's Trigger. Plug the Power Cord into a properly grounded, GFCI protected 120VAC (20 amp rated) or 240VAC receptacle that matches the plug and turn the Power Switch ON. The circuit must be equipped with delayed action-type circuit breaker or fuses.

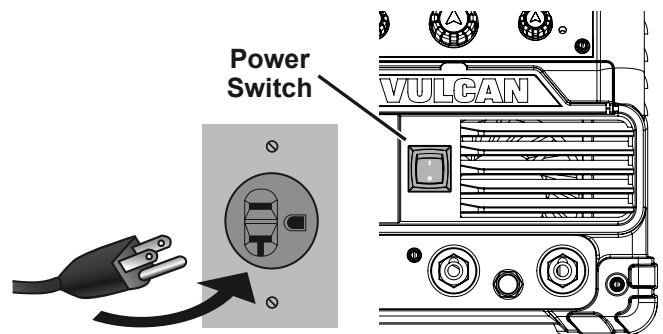

26. Point the Gun away from all objects. Press and hold the Cold Wire Feed Switch until the wire feeds through two inches.

The wire liner may come out with the welding wire. This is normal, just push the wire liner back into the Gun.

If the wire does not feed properly and the Spool is stationary, turn OFF and unplug the Welder and slightly tighten the Feed Tensioner clockwise before retrying.

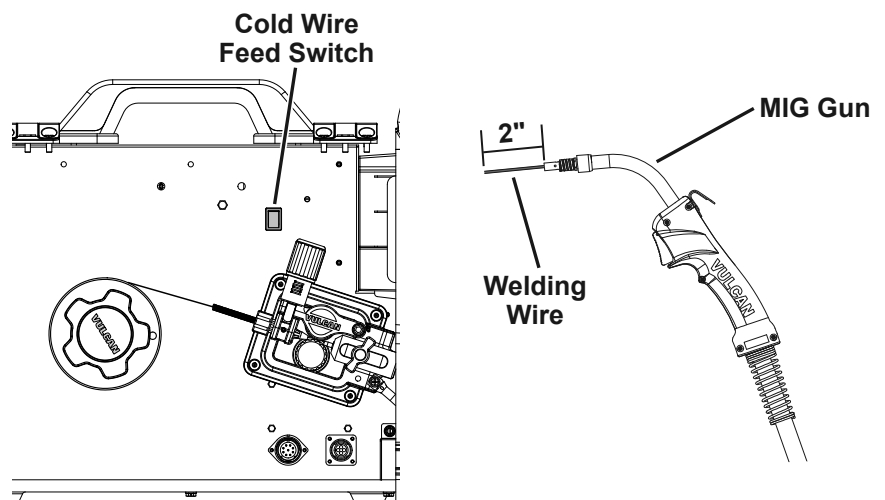

- To check the wire's drive tension, press and hold Trigger to feed the wire against a piece of wood from 2 to 3 inches away.

Note: After pressing Trigger, wire will stop feeding after 3 seconds if there is no arc. Check tension for less than 3 seconds.

If the wire stops instead of bending, unplug the Welder, slightly tighten the Feed Tensioner clockwise, and try again. If the wire bends from the feed pressure, then the tension is set properly. Before proceeding, turn OFF the Power Switch and unplug the Power Cord from its electrical outlet.

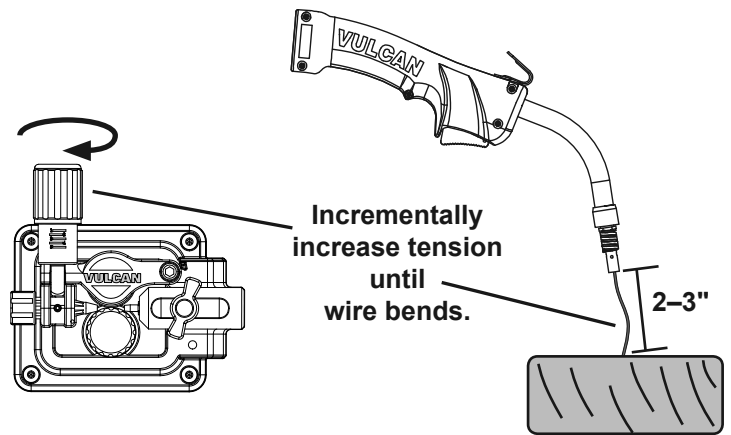

- Turn OFF the Power Switch and unplug the Power Cord from its electrical outlet.

- Close the Door. Make sure Door is securely latched.

- Select a Contact Tip that is compatible with the welding wire used. Slide the Contact Tip over the wire and thread it clockwise into the MIG Gun. Tighten the Contact Tip.

- Replace the Nozzle and cut the wire off at 1/2" from tip (1/2" stickout).

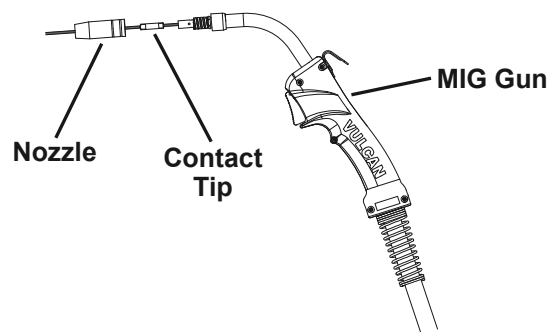

Optional Spool Gun Setup

- To set up optional Spool Gun (sold separately), plug Ground Clamp Cable into Negative (-) Socket. Plug Wire Feed Power Cable into Positive (+) Socket. Twist cables clockwise all the way to lock in place.
- Loosen the Knob on the Wire Feed mechanism, then insert the Spool Gun Cable Connector through the hole on the Welder front and into the socket on the Wire Feed.

- Ensure Cable Connector is fully inserted and tighten the Knob securely. If Connector is not fully inserted, the gas connection will leak, preventing shielding gas from reaching the welding arc.

NOTICE: To prevent damage, do not overtighten the Knob.

- Insert the Wire Feed Control Cable through hole on Welder front and connect to the Wire Feed Control Socket inside the machine, then tighten lock ring on the Cable plug. Note that the plug on the Cable fits into the Socket in one specific orientation only.

- Connect Gas Hose on Spool Gun Cable Connector to Spool Gun Gas Outlet on front of Welder. Refer to paragraph 17 on page 14 for further shielding gas setup information.

- Refer to Spool Gun manual for operational information.

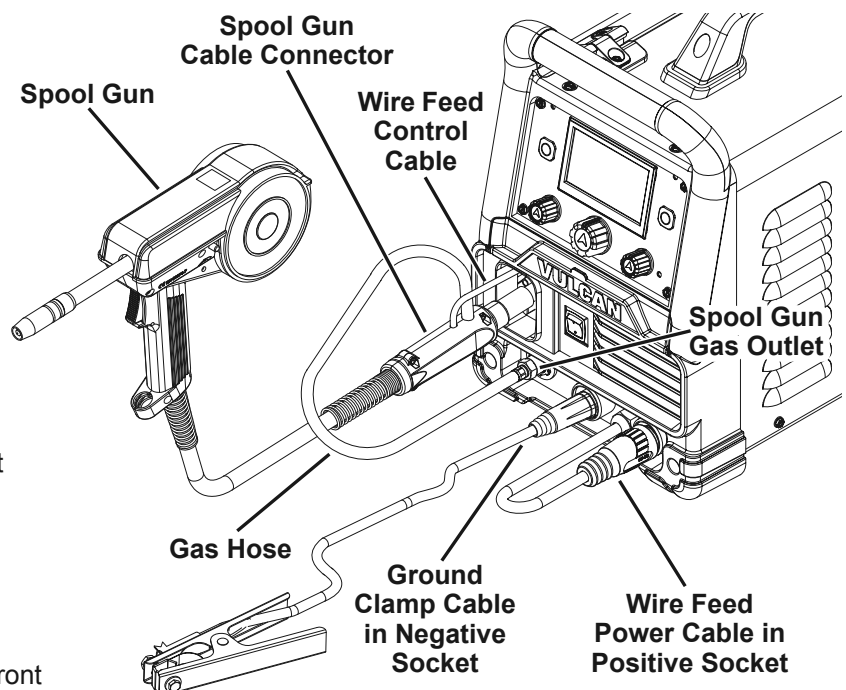

Basic Wire Welding

SAFETY



Read the **ENTIRE IMPORTANT SAFETY INFORMATION** section at the beginning of this manual including all text under subheadings therein before welding.

⚠️ WARNING

TO PREVENT SERIOUS INJURY:

Protective gear must be worn when using the Welder; minimum shade number 10 full face shield (or welding mask), ear protection, welding gloves, sleeves and apron, NIOSH-approved respirator, and fire resistant work clothes without pockets should be worn when welding.

Light from the arc can cause permanent damage to the eyes and skin.

Do not breathe arc fumes.

Flux-cored wire welding is used to weld mild steel and stainless steel without shielding gas.

MIG welding uses solid wire and shielding gas, and is used to weld mild steel and stainless steel. MIG welding can also be used to weld thinner workpieces than flux-cored welding can.

Aluminum welding can be performed with an optional Spool Gun (sold separately) using aluminum wire and shielding gas.

Good welding takes a degree of skill and experience. Practice a few sample welds on scrap before welding your first project. Additional practice periods are recommended whenever you weld:

- a different thickness of material
- a different type of material
- a different type of connection
- using a different process

Make practice welds on pieces of scrap to practice technique before welding anything of value.



CONTROLS

WIRE

TIG / STICK

WELDING TIPS

MAINTENANCE

⚠️ WARNING



TO PREVENT SERIOUS INJURY, FIRE AND BURNS:
Keep welding tip clear of grounded objects whenever unit is plugged in and turned on.

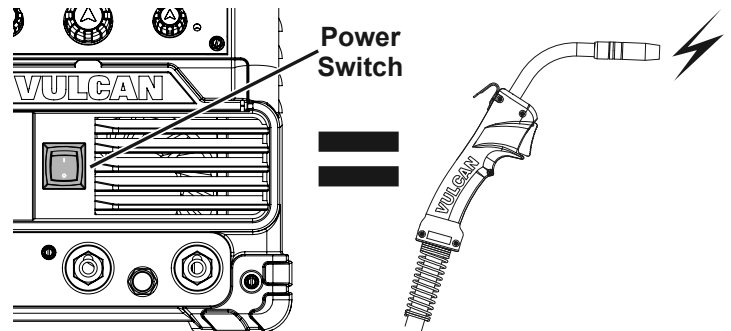

Practice your welding technique on scrap pieces before welding anything of value.

Duty Cycle (Duration of Use)

Avoid damage to the Welder by not welding for more than the prescribed duty cycle time. The Duty Cycle defines the number of minutes, within a 10 minute period, during which a given welder can produce a particular welding current without overheating.

For example, a welder with a 40% duty cycle at 100A welding current must be allowed to rest for at least 6 minutes after every 4 minutes of continuous welding.

Failure to carefully observe duty cycle limitations can easily over-stress a welder's power generation system contributing to premature welder failure.

This Welder has an internal thermal protection system to help prevent this sort of over-stress. When the Welder overheats, it automatically shuts down and a warning screen appears in the LCD Display window. The Welder automatically returns to service after cooling off. Should this occur, rest the MIG Gun on an electrically non-conductive, heat-proof surface, such as a concrete slab, well clear of the ground clamp.

Allow the Welder to cool with the Power Switch on, so that the internal Fan will help cool the Welder.

When normal operation resumes, use shorter welding periods and longer rest periods to prevent needless wear.

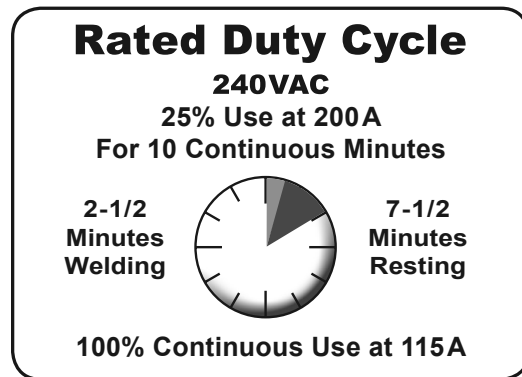
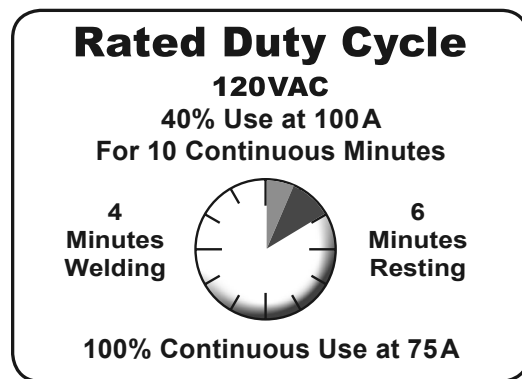

Setting Up The Weld

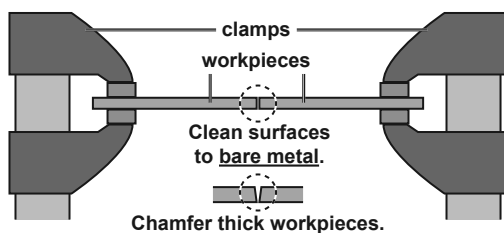

1. **Make practice welds on pieces of scrap the same thickness as your intended workpiece to practice technique before welding anything of value.** Clean the weld surfaces thoroughly with a wire brush or angle grinder; there must be no rust, paint, oil, or other materials on the weld surfaces, only bare metal.

2. Use clamps (not included) to hold the workpieces in position so that you can concentrate on proper welding technique. The distance (if any) between the two workpieces must be controlled properly to allow the weld to hold both sides securely while allowing the weld to penetrate fully into the joint. The edges of thicker workpieces may need to be chamfered (or beveled) to allow proper weld penetration.

Notice: When welding equipment on a vehicle, disconnect the vehicle battery power from both the positive connection and the ground before welding. This prevents damage to some vehicle electrical systems and electronics due to the high voltage and high frequency bursts common in welding.

3. Clamp Ground Cable to bare metal on the workpiece near the weld area, or to metal work bench where the workpiece is clamped.

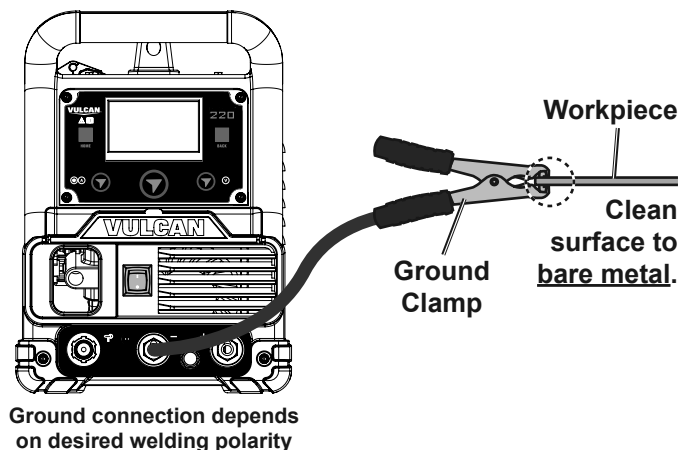

- Turn the Power Switch to the OFF position, then plug the Power Cord into a properly grounded, GFCI protected 120VAC (20 amp rated) or 240VAC receptacle that matches the plug. The circuit must be equipped with delayed action-type circuit breaker or fuses.

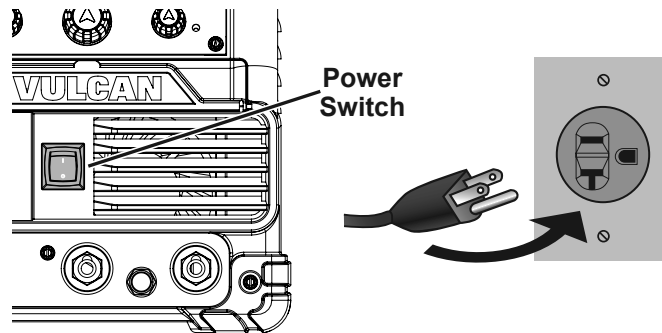

- Set MIG Gun down on nonconductive, nonflammable surface away from any grounded objects.

- Turn the Power Switch ON.

Settings



Left Knob

Main Control Knob

Right Knob

- Press Home Button on Control Panel.
- Turn Main Control Knob until desired process appears on LCD display screen.
- Press Main Control Knob to select process.

Note: Press Main Control Knob to go to next screen. Press Back Button to return to the previous screen.

- Adjust settings for the selected process.

a. Polarity and Gas Settings:

- Plug cables in according to screen.
- Connect gas according to screen.
- Set SCFH between 20-30.



b. Set Wire Diameter and Material Thickness:

- Turn Left Knob to set wire diameter.
- Turn Right Knob to set material thickness.



c. Auto Weld Settings:

- Turn Left Knob to adjust Wire Feed Speed (Amperage).
- Turn Right Knob to adjust Voltage.

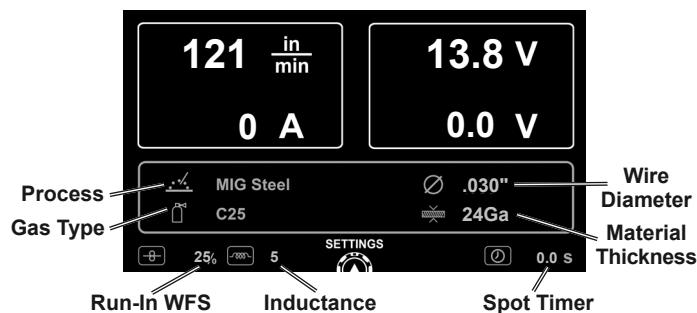

Note: If the Wire Feed Speed or Voltage settings are adjusted manually, the white mark on the line shows the recommended setting for your wire/electrode diameter and workpiece thickness.

d. Optional Settings:

- Press Main Control Knob to enter Optional Settings.
- Turn Main Control Knob until desired setting appears on screen.
- Press Main Control Knob to select desired setting.
- Turn Main Control Knob to adjust setting.

Available Optional Settings:

- Run-In WFS—Adjust wire speed before it contacts workpiece. This setting represents a % of the pre-set wire feed speed (WFS).
- Inductance—Adjust length of arc. Increase for more fluid puddle and flatter bead. Decrease for colder puddle.
- Spot Timer—Set timer for spot welding.
- Recall Setting—Retrieve saved settings.
- Save Setting—Program up to 5 different configurations. Turn Main Control Knob to scroll between 5 available slots. Press Main Control Knob to access OVERWRITE MEMORY SETTING screen and turn Main Control Knob to choose YES selection. Press Main Control Knob to save current Welder settings.

Note: The initial settings may need to be adjusted after stopping and carefully inspecting the weld. Proper welding takes experience.

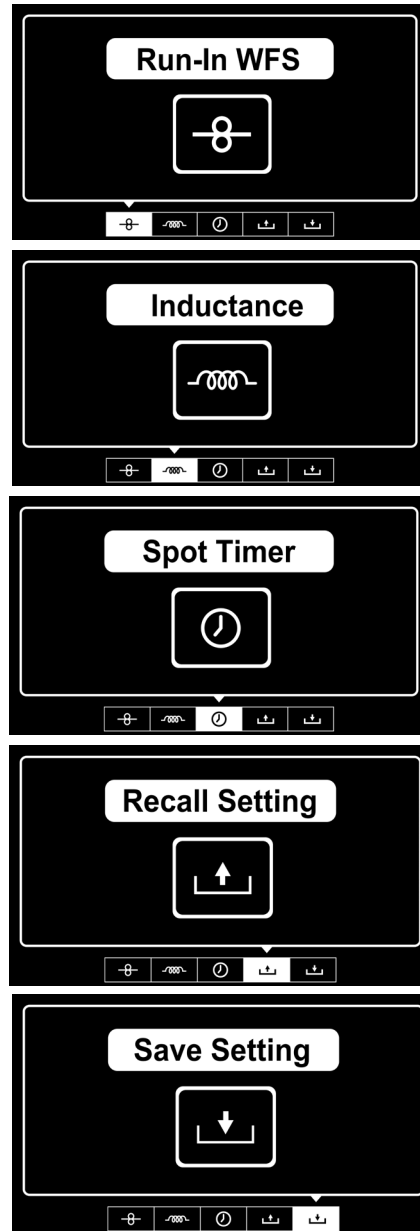

Gas Shielded, Solid-Core Wire Only

DANGER! TO PREVENT DEATH FROM ASPHYXIATION:

Do not open gas without proper ventilation. Fix gas leaks immediately.

Shielding gas can displace air and cause rapid loss of consciousness and death.

Shielding gas without carbon dioxide can be even more hazardous because asphyxiation can start without feeling shortness of breath.



1. Open gas cylinder valve all the way.
2. Set Flow Gauge to SCFH value indicated on Settings Chart.

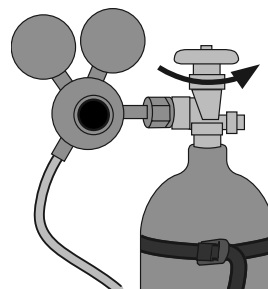

Basic Wire Welding Technique

SAFETY

1. Press (and hold) Trigger and contact the area to be welded with electrode wire to ignite arc.
2. For a narrow weld, you can usually draw the wire in a steady straight line. This is called a **stringer bead**.

For a wider weld, draw the wire back and forth across the joint. This is called a **weave bead** and takes practice to perform properly.

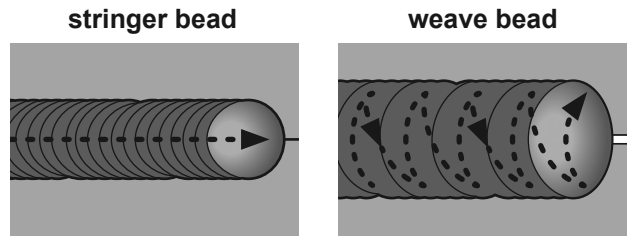

CONTROLS

3. Direct the welding wire straight into the joint. This gives an angle of 90° (straight up and down) for butt (end to end) welds, and an angle of 45° for fillet (T-shaped) welds.

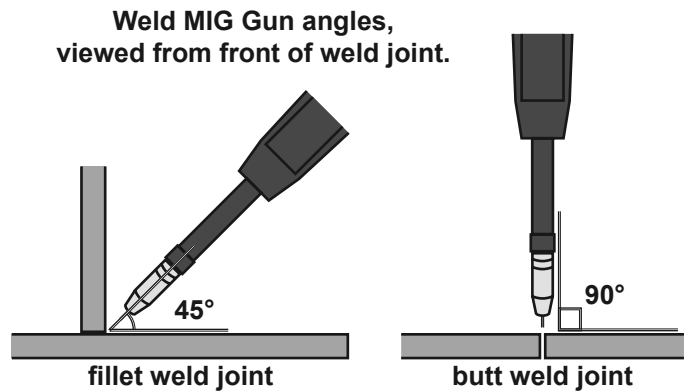

WIRE

4. For MIG welding using solid wire and shielding gas, the end of the MIG Gun should be tilted so that wire is angled anywhere in-between straight on and 15° away from the direction you are welding. The amount of tilt is called the **push angle**.

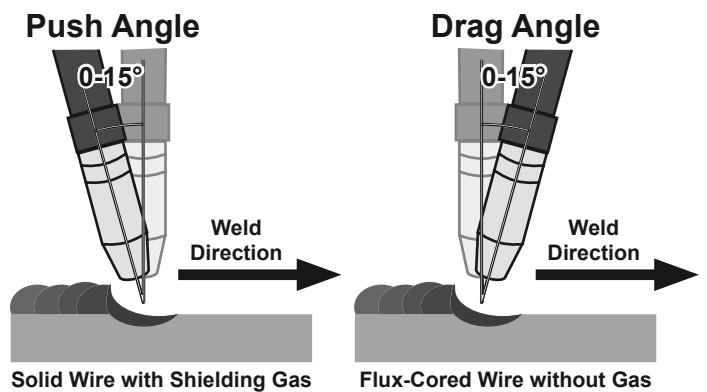

TIG / STICK

5. When using flux-cored wire without shielding gas, the end of the MIG Gun should be tilted so that wire is angled anywhere in-between straight on and 15° in the direction you are welding. The amount of tilt is called the **drag angle**.

WELDING TIPS

6. The Contact Tip should remain within 1/2" of the work surface. This distance is called **CTWD** - Contact Tip to Work Distance.

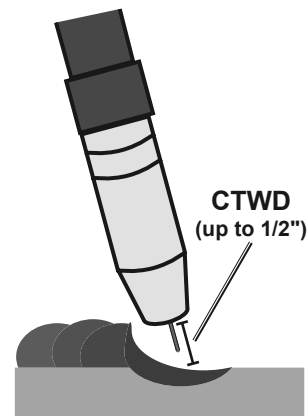

MAINTENANCE

Note: If Welder is used too long, a warning screen appears in the LCD Display window and the unit automatically shuts down. The Welder automatically returns to service after cooling off. Should this occur, rest the MIG Gun on an electrically non-conductive, heat-proof surface, such as a concrete slab, away from the ground clamp.

Allow the Welder to cool with the Power Switch on, so that the internal Fan will help cool the Welder.

When normal operation resumes, use shorter welding periods and longer rest periods to help prevent needless wear.

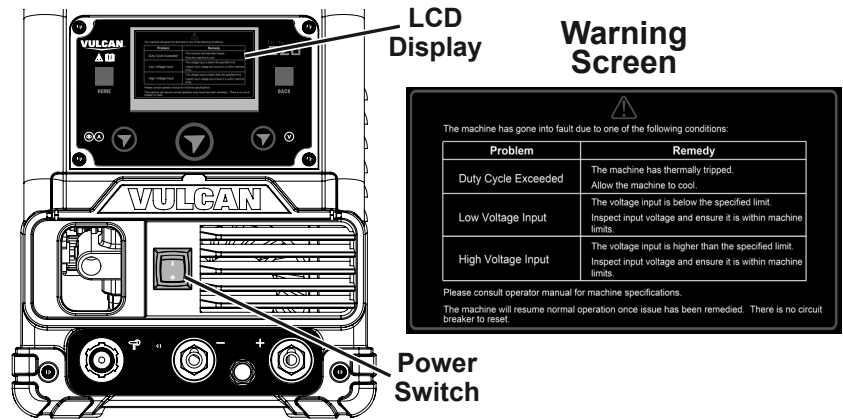

7. **After welding the test weld on a piece of scrap for a few seconds, stop, and check your progress.** Clean, then compare your weld's appearance with the diagrams and descriptions in the **Welding Tips** section starting on the next page. After making any necessary adjustments, continue to weld **while carefully following the DUTY CYCLE guidelines as explained on page 19.**

After practice welding for a few seconds, STOP and examine your weld using the guidelines starting on the next page.

FOLLOW DUTY CYCLE!

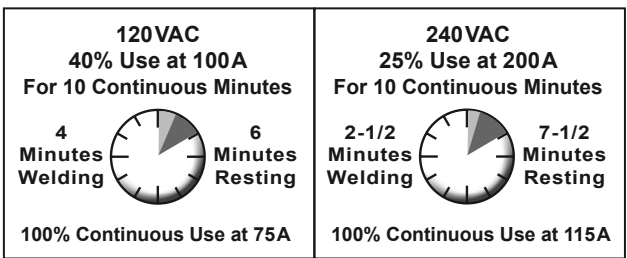

CAUTION! Weld will be hot, do not touch.

8. **When welding is complete, set the MIG Gun down on a heat-proof, electrically non-conductive surface.** Turn the Power Switch OFF.
9. Allow Welder to cool down, then unplug the Power Cord.
10. Remove Ground Clamp from workpiece or table and disconnect MIG Gun.
11. Respool wire by clipping wire, removing gas nozzle/contact tip on MIG gun, releasing Idler Arm on Wire Feed mechanism, and rotating the Wire Spool counterclockwise. Be sure to securely hold wire as it is being respooled because the end of wire has a tendency to quickly unravel once it clears the wire feeder.
12. **MIG ONLY:** **Close shielding gas cylinder valve securely.** Remove Regulator and replace cap. Disconnect Gas Hose from Welder. Store and secure gas cylinder.

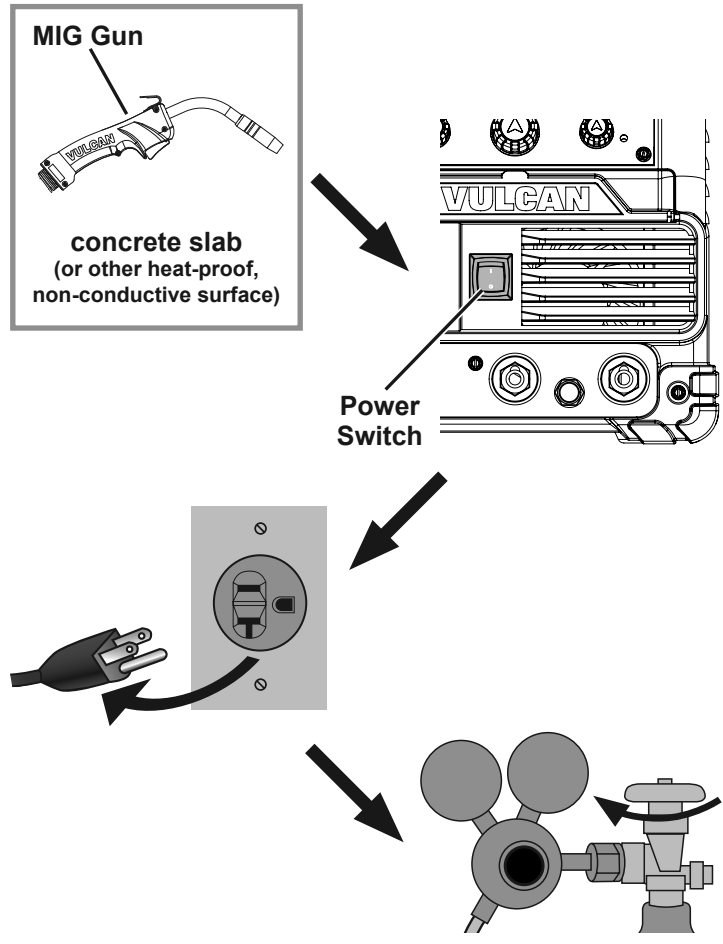

SAFETY

CONTROLS

WIRE

TIG / STICK

WELDING TIPS

MAINTENANCE

TIG/Stick Welding



Read the **ENTIRE IMPORTANT SAFETY INFORMATION** section at the beginning of this manual including all text under subheadings therein before set up or use of this product.



WARNING TO PREVENT SERIOUS INJURY FROM ACCIDENTAL OPERATION: Turn the Power Switch off and unplug the Welder before setup.

Note: Remove the protective foam and cardboard from the Welder before setup. Place the Welder on a level surface that can bear its weight near the work area. Leave space around the Welder for proper air flow.

TIG Setup

Connect Cables

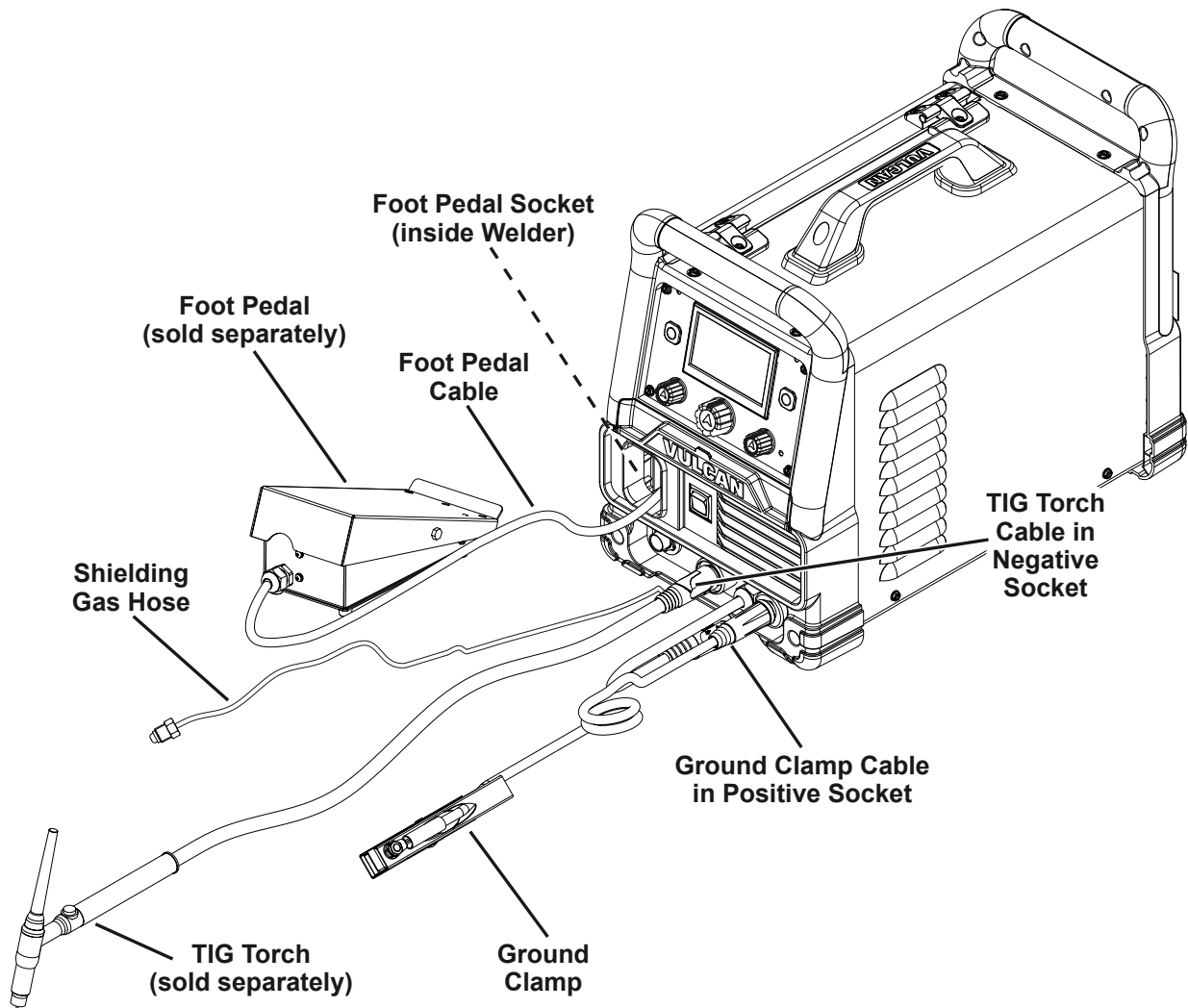

1. Plug Ground Clamp Cable into Positive Socket. Twist clockwise all the way to lock in place.
2. Plug TIG Torch Cable (TIG Torch sold separately) into Negative Socket. Twist clockwise all the way to lock in place.
3. Insert the Foot Pedal Cable (Foot Pedal sold separately) through hole on Welder front and connect to the Foot Pedal Socket inside the machine. Secure by turning collar clockwise until tight.
4. For connecting Shielding Gas Hose, refer to *Connect Shielding Gas* section on next page.

Connect Shielding Gas

1. With assistance, place an 100% Argon cylinder (not included) onto a cabinet or cart near the Welder and secure the cylinder in place with two straps (not included) to prevent tipping.
2. Remove the cylinder's cap. Stand to the side of the valve opening, then open the valve briefly to blow dust and dirt from the valve opening. Close the cylinder valve.
3. Locate the Regulator (included) and close its valve until it is loose, then thread Regulator onto cylinder and wrench-tighten connection.
4. Connect Shielding Gas Hose on TIG Torch Cable Connector to the Regulator's Outlet and wrench-tighten connection.

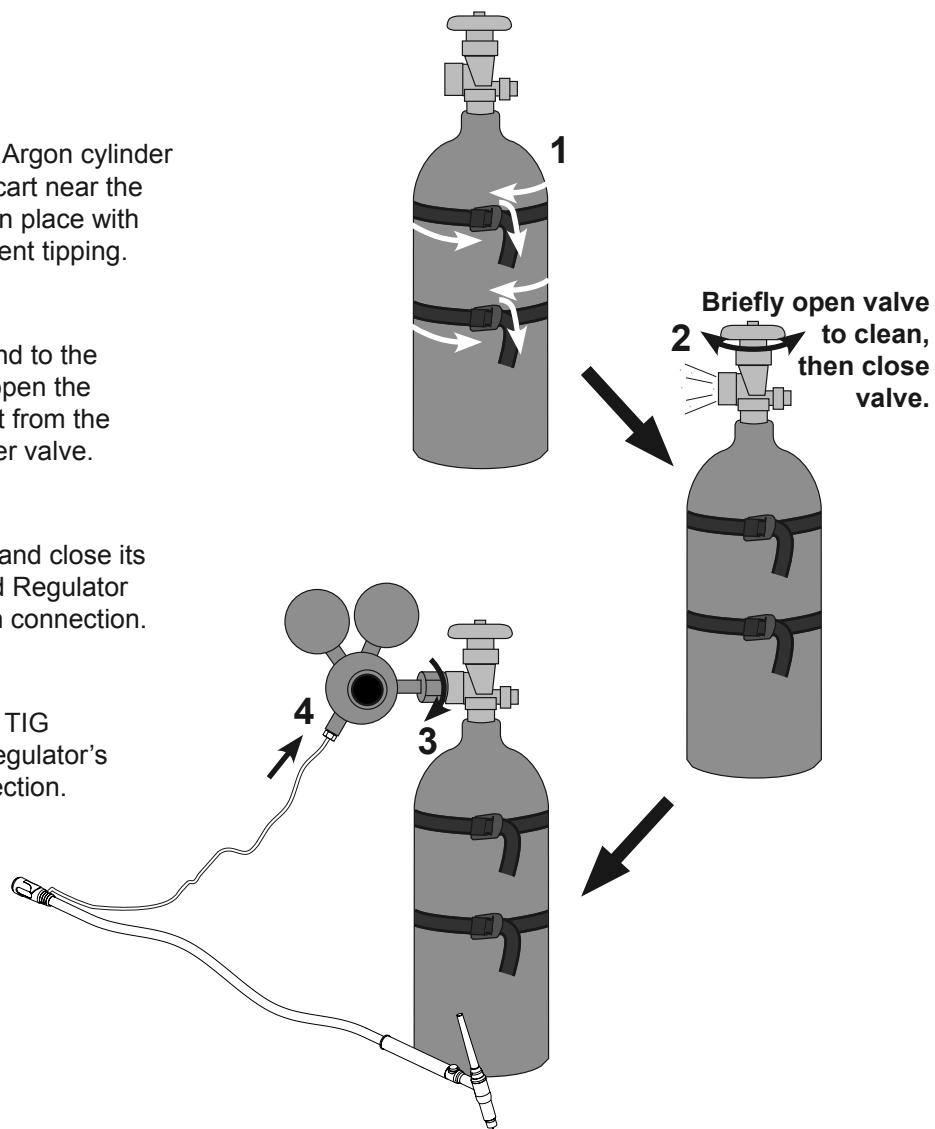

Connect Power Cord

Plug either 120VAC or 240VAC Power Cord into Power Input Socket.

Note: Plug will only fit one way.

WARNING! TO PREVENT SERIOUS INJURY FROM ACCIDENTAL OPERATION: Do not plug cord into wall outlet at this time.

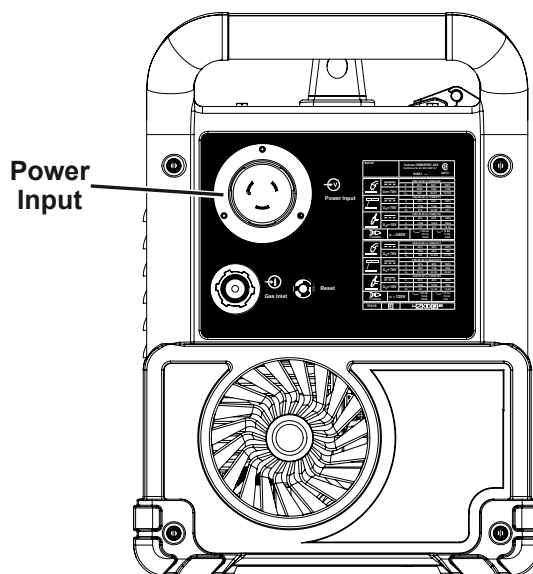

SAFETY

CONTROLS

WIRE

TIG / STICK

WELDING TIPS

MAINTENANCE

Sharpen Tungsten Electrode (sold separately)

To avoid Electrode contamination, dedicate a fine grit grinding wheel exclusively to Electrode grinding.

WARNING! Some Electrodes may have materials added to them that are hazardous to breathe. Wear a respirator and ANSI-approved Safety goggles when grinding an Electrode.

1. Shut off the welder and wait until Electrode and Torch have cooled enough to handle.
2. Remove Back Cap. Pull Electrode from front of Torch. (Pulling it from rear will damage Collet and create burrs on Electrode).
3. If Electrode has dulled or been otherwise contaminated, use pliers or a suitable tool to grip the Electrode above the contaminated section and snap off the end of the Electrode.

4. Lightly press Electrode tip against the surface of the grinding wheel at an angle. Rotate Electrode tip until a blunt point is formed.

Note: Grinding direction must be parallel to length of Electrode.

5. The conical portion of the ideal tip will be 2-1/2 times as long as the Electrode diameter.
6. Re-insert Electrode into Collet with tip protruding 1/8"-1/4" beyond the Ceramic Nozzle, then re-tighten the Back Cap.

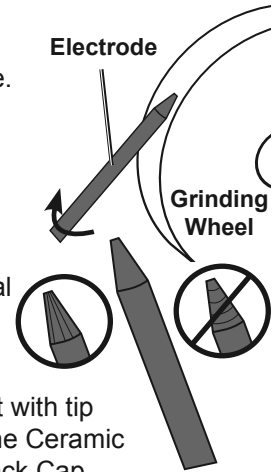

Assemble TIG Torch (sold separately)

1. Consult Settings Chart, on top of Welder, to determine proper Tungsten Electrode size to be used with thickness of material to be welded.
2. Match Collet and Collet Body sizes to Tungsten Electrode size.
3. Thread Collet Body into the front of the Torch.
4. Make sure Ceramic Nozzle size is appropriate for application.
5. Thread Ceramic Nozzle onto Collet Body.
6. Insert Collet into back of Torch and into Collet Body.
7. Insert Tungsten Electrode into Collet on front of Torch.

8. Lock Electrode in place with Back Cap. Electrode should protrude 1/8" to 1/4" beyond the Ceramic Nozzle.

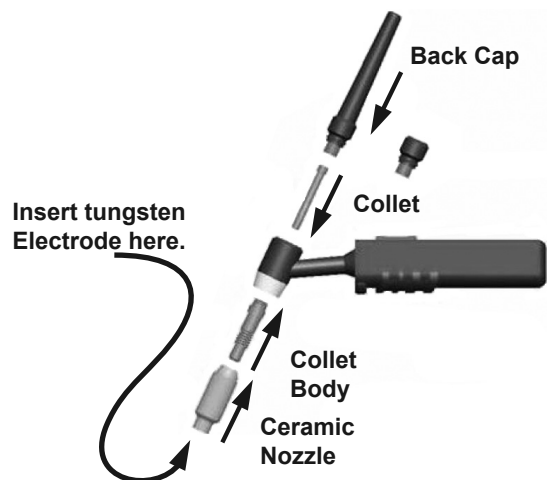

Stick Setup

Connect Cables

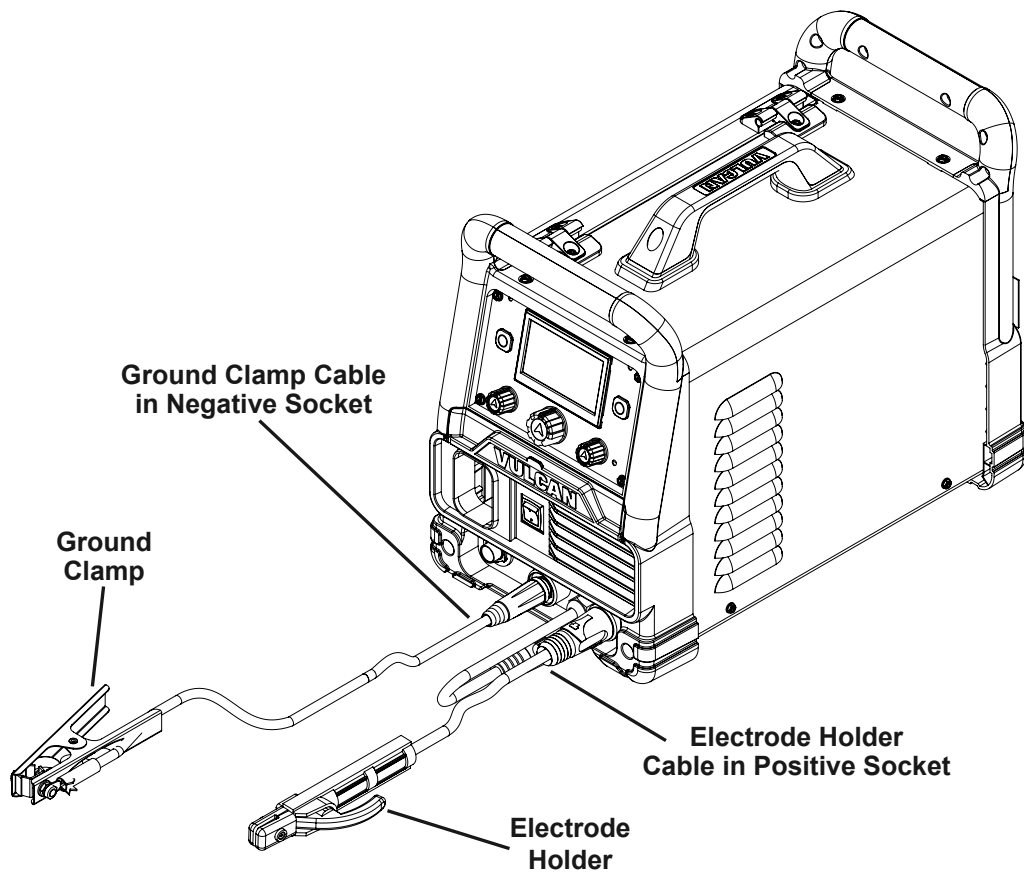

1. Plug Ground Clamp Cable into Negative Socket. Twist clockwise all the way to lock in place.
2. Plug Electrode Holder Cable into Positive Socket. Twist clockwise all the way to lock in place.

Connect Power Cord

Plug either 120VAC or 240VAC Power Cord into Power Input Socket.

Note: Plug will only fit one way.

WARNING! TO PREVENT SERIOUS INJURY FROM ACCIDENTAL OPERATION: Do not plug cord into wall outlet at this time.

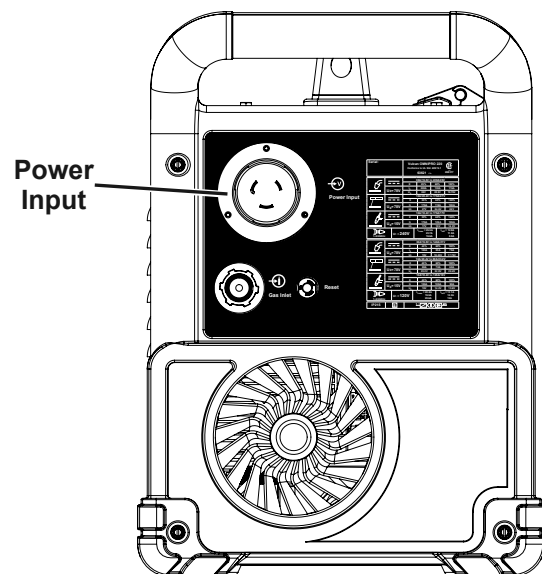

Basic TIG/Stick Welding

SAFETY



Read the **ENTIRE IMPORTANT SAFETY INFORMATION** section at the beginning of this manual including all text under subheadings therein before set up or use of this product.

CONTROLS

⚠️ WARNING

TO PREVENT SERIOUS INJURY:

Protective gear must be worn when using the Welder; minimum shade number 10 full face shield (or welding mask), ear protection, welding gloves, sleeves and apron, NIOSH-approved respirator, and fire resistant work clothes without pockets should be worn when welding. Light from the arc can cause permanent damage to the eyes and skin. Do not breathe arc fumes.

- DC TIG Welding is used to weld mild steel and stainless steel using a TIG Rod and shielding gas.
- AC TIG Welding is used to weld aluminum using a TIG Rod and shielding gas.
- Stick Welding is used to weld mild steel and stainless steel using a Stick Electrode without shielding gas.



WIRE

Good welding takes a degree of skill and experience. Practice a few sample welds on scrap before welding your first project. Additional practice periods are recommended whenever you weld:

- a different thickness of material
- a different type of material
- a different type of connection
- using a different process



TIG / STICK

Make practice welds on pieces of scrap to practice technique before welding anything of value.

WELDING TIPS

⚠️ WARNING



TO PREVENT SERIOUS INJURY, FIRE AND BURNS:
Keep welding tip clear of grounded objects whenever unit is plugged in and turned on.

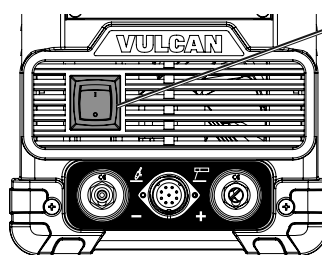

Power On

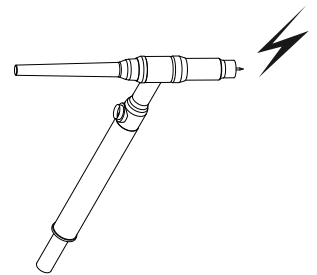

MAINTENANCE

Practice your welding technique on scrap pieces before welding anything of value.

Duty Cycle (Duration of Use)

Avoid damage to the Welder by not welding for more than the prescribed duty cycle time. The Duty Cycle defines the number of minutes, within a 10 minute period, during which a given welder can produce a particular welding current without overheating.



For example, a welder with a 40% duty cycle at 125A welding current must be allowed to rest for at least 6 minutes after every 4 minutes of continuous welding.



Failure to carefully observe duty cycle limitations can easily over-stress a welder's power generation system contributing to premature welder failure.

This Welder has an internal thermal protection system to help prevent this sort of over-stress. When the Welder overheats, it automatically shuts down and a warning screen appears in the LCD Display window. The Welder automatically returns to service after cooling off. Should this occur, rest the Tig Torch or Electrode Holder on an electrically non-conductive, heat-proof surface, such as a concrete slab, well clear of the ground clamp.

Allow the Welder to cool with the Power Switch on, so that the internal Fan will help cool the Welder.

When normal operation resumes, use shorter welding periods and longer rest periods to prevent needless wear.

TIG Rated Duty Cycles	
<p>240VAC 30% Use at 175A For 10 Continuous Minutes</p> <p>3 Minutes Welding 7 Minutes Resting</p>  <p>100% Continuous Use at 105A</p>	<p>120VAC 40% Use at 125A For 10 Continuous Minutes</p> <p>4 Minutes Welding 6 Minutes Resting</p>  <p>100% Continuous Use at 90A</p>

Stick Rated Duty Cycles	
<p>240VAC 25% Use at 175A For 10 Continuous Minutes</p> <p>2-1/2 Minutes Welding 7-1/2 Minutes Resting</p>  <p>100% Continuous Use at 100A</p>	<p>120VAC 40% Use at 80A For 10 Continuous Minutes</p> <p>4 Minutes Welding 6 Minutes Resting</p>  <p>100% Continuous Use at 60A</p>

Setting up the Weld

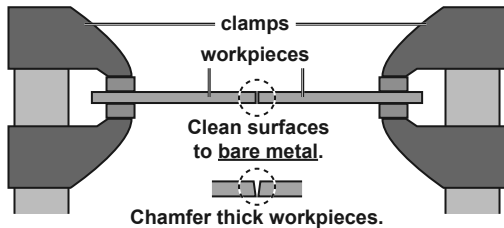

1. **Make practice welds on pieces of scrap the same thickness as your intended workpiece to practice technique before welding anything of value.** Clean the weld surfaces thoroughly with a wire brush or angle grinder; there must be no rust, paint, oil, or other materials on the weld surfaces, only bare metal.

2. Use clamps (not included) to hold the workpieces in position so that you can concentrate on proper welding technique. The distance (if any) between the two workpieces must be controlled properly to allow the weld to hold both sides securely while allowing the weld to penetrate fully into the joint. The edges of thicker workpieces may need to be chamfered (or beveled) to allow proper weld penetration.

NOTICE: When welding equipment on a vehicle, disconnect the vehicle battery power from both the positive connection and the ground before welding. This prevents damage to some vehicle electrical systems and electronics due to the high voltage and high frequency bursts common in welding.

3. Clamp Ground Cable to bare metal on the workpiece near the weld area, or to metal work bench where the workpiece is clamped.

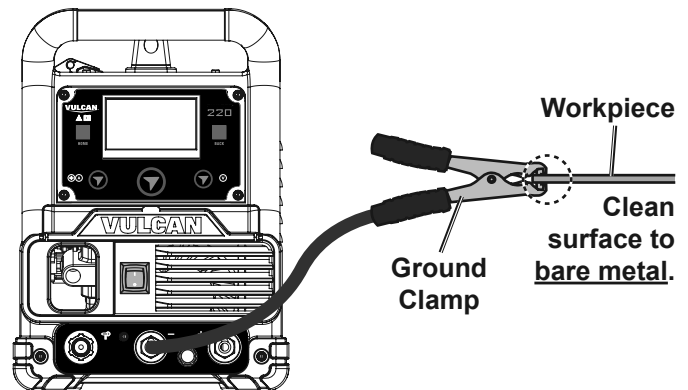

Ground connection depends on desired welding polarity

TIG Welding

⚠️ WARNING

TO PREVENT SERIOUS INJURY AND DEATH:

Do not weld without Grounding Clamp.

When the operator is not holding the Torch, it must be sitting on a nonconductive, nonflammable surface. Only hold TIG Rod with an electrically insulated welding glove.

⚠️ DANGER

TO PREVENT DEATH FROM ASPHYXIATION:

Do not open gas without proper ventilation. Fix gas leaks immediately. Shielding gas can displace air and cause rapid loss of consciousness and death. **Shielding gas without carbon dioxide can be even more hazardous because asphyxiation can start without feeling shortness of breath.**

NOTICE: TIG welding is a complicated process, requiring experience and skill to achieve successful results. Training beyond the scope of this manual is required to TIG weld properly.

1. Open gas cylinder's valve all the way.
2. Set Flow Gauge to SCFH value indicated on the Settings Chart on the inside of the Welder door.
3. Turn the Power Switch to the OFF position, then plug the Welder into a properly grounded, GFCI protected, 120VAC (20 amp rated) outlet or 240V outlet. The circuit must be equipped with delayed action-type circuit breaker or fuses.
4. Set TIG Torch down on nonconductive, nonflammable surface away from any grounded objects.
5. Turn the Power Switch ON.
6. Press Home Button on Control Panel.
7. Turn Main Control Knob until TIG process appears on LCD display screen.
8. Press Main Control Knob to select TIG process.

Note: Press Main Control Knob to go to next screen. Press Back Button to return to the previous screen.

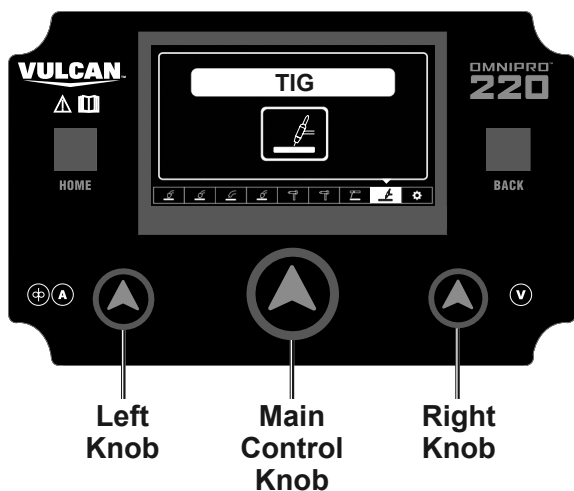

9. Adjust settings for the TIG process.

a. Polarity and Gas Settings:

- Plug cables in according to screen.
- Connect gas according to screen.
- Set SCFH between 10-25.

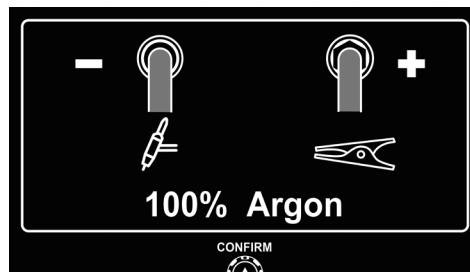

b. Set Rod Diameter and Material Thickness:

- Turn Left Knob to set rod diameter.
- Turn Right Knob to set material thickness.



c. Auto Weld Settings:

- Turn Left Knob to adjust output amperage.
- Turn Right Knob to ON to energize TIG Torch.

WARNING! Welder is now energized and Open Circuit Voltage is present.

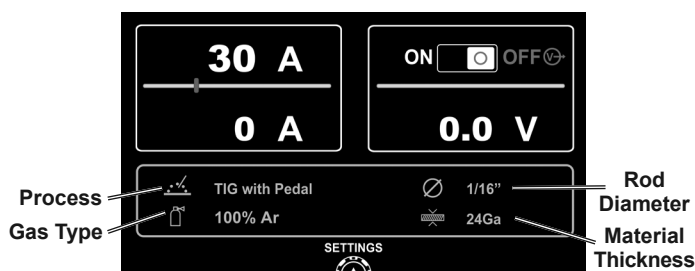

- d. Optional Settings:
- Press Main Control Knob to enter Optional Settings.
 - Turn Main Control Knob until desired setting appears on screen.
 - Press Main Control Knob to select desired setting.
 - Turn Main Control Knob to adjust setting.
- Available Optional Settings:
- Recall Setting—Retrieve saved settings.
 - Save Setting—Program up to 5 different configurations.

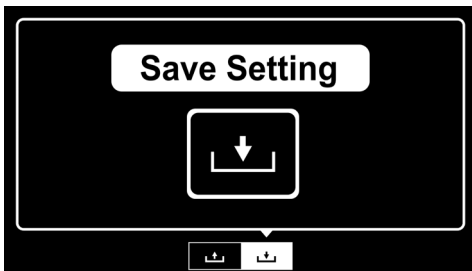
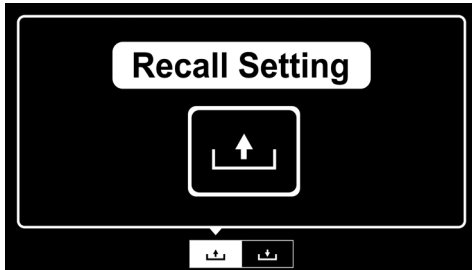

Note: The initial settings may need to be adjusted after stopping and carefully inspecting the weld. Proper welding takes experience.

WARNING! TO PREVENT SERIOUS INJURY: Protective gear must be worn when using the Welder; minimum shade number 10 full face shield (or welding mask), ear protection, welding gloves, sleeves and apron, NIOSH-approved respirator, and fire resistant work clothes without pockets should be worn when welding. Light from the arc can cause permanent damage to the eyes and skin. Do not breathe arc fumes.

After practice welding on scrap, stop, and check your progress. Perform Strike Test according to **Strike Test on page 34**. After making any necessary adjustments, continue to weld **while carefully following the DUTY CYCLE guidelines as explained on page 29**.

WARNING! Metal work bench must be grounded when TIG welding.

10. Hold TIG Torch in one gloved hand and the TIG Rod (sold separately) in other gloved hand.

NOTE: Maintain a constant distance between the Tungsten Electrode and the workpiece: between 1 and 1.5 times the diameter of the Electrode.

11. Open valve on TIG Torch to start gas flow.
12. To initiate welding arc, push Foot Pedal and touch Electrode to work piece and lift. If not using Foot Pedal, touch Electrode to work piece and lift.
13. When welding puddle is hot enough, tilt Torch backward about 10-15 degrees from vertical and move it back slightly. Add TIG Rod material as needed to the front end of the weld puddle.
14. Alternate between pushing the torch/weld puddle and adding the TIG Rod material.

NOTE: Remove the TIG Rod each time the Electrode is advanced, but do not remove it from the gas shield. This prevents oxidation from contaminating the weld.

15. When finished welding, release the Foot Pedal but keep Torch on weld puddle until weld solidifies. If not using Foot Pedal, pull Torch away from work piece until welding arc is broken, then return the gas coverage until weld solidifies.

16. Close valve on TIG Torch and turn Right Knob to OFF to turn off power to TIG Torch.

17. Set TIG Torch down on nonconductive, nonflammable surface away from any grounded objects.

18. Turn the Power Switch OFF.

19. To prevent accidents, after use:
 - Allow Welder to cool down.
 - Unplug Welder's power cord from outlet.
 - Remove Ground Clamp from workpiece or table.
 - Disconnect TIG Torch, Ground and Foot Pedal Cables.
 - Close gas cylinder's valve securely, remove regulator and replace cap.
 - Disconnect Gas Hose from Welder.
 - Store and secure gas cylinder.
 - Clean, then store Welder and its accessories indoors out of children's reach.

Stick Welding

SAFETY

CONTROLS

WIRE

TIG / STICK

WELDING TIPS

MAINTENANCE

⚠️ WARNING

TO PREVENT SERIOUS INJURY AND DEATH:

Do not weld without Grounding Clamp.

When the operator is not holding the Electrode Holder, it must be sitting on a nonconductive, nonflammable surface.

1. Turn the Power Switch to the OFF position, then plug the Welder into a properly grounded, GFCI protected, 120VAC (20 amp rated) outlet or 240V outlet. The circuit must be equipped with delayed action-type circuit breaker or fuses.
2. Set Electrode Holder down on nonconductive, nonflammable surface away from any grounded objects.
3. Turn the Power Switch ON.
4. Press Home Button on Control Panel.
5. Turn Main Control Knob until Stick process appears on LCD display screen.
6. Press Main Control Knob to select STICK process.

Note: Press Main Control Knob to go to next screen. Press Back Button to return to the previous screen.

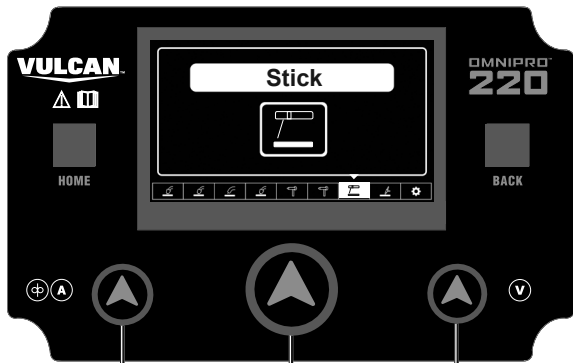

Left Knob

Main Control Knob

Right Knob

7. Adjust settings for the STICK process.

a. Polarity Setting:

- Plug cables in according to screen.



b. Set Electrode type:

- Turn Main Control Knob to set electrode type.

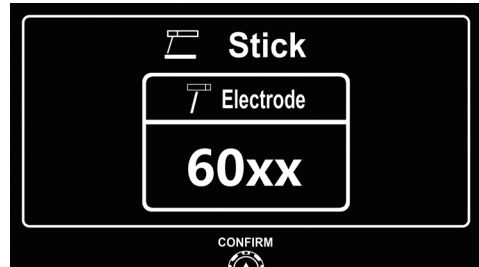

c. Set Electrode Diameter and Material Thickness:

- Turn Left Knob to set electrode diameter.
- Turn Right Knob to set material thickness.



d. Auto Weld Settings:

- Turn Left Knob to adjust output amperage.
- Turn Right Knob to ON to energize Electrode Holder.

WARNING! Welder is now energized and Open Circuit Voltage is present.

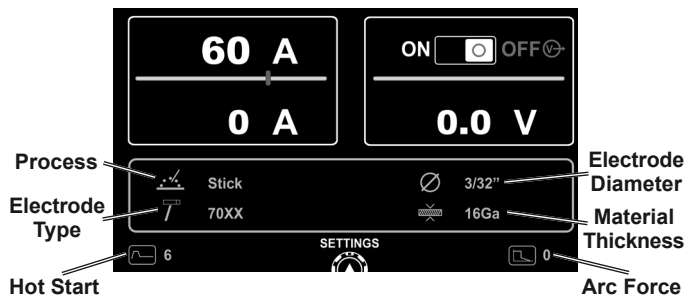

e. Optional Settings:

- Press Main Control Knob to enter Optional Settings.
- Turn Main Control Knob until desired setting appears on screen.
- Press Main Control Knob to select desired setting.
- Turn Main Control Knob to adjust setting.

Available Optional Settings:

- Hot Start—Adjust amperage at start of weld.
- Arc Force—Adjust weld penetration and smoothness.
- Recall Setting—Retrieve saved settings.
- Save Setting—Program up to 5 different configurations.

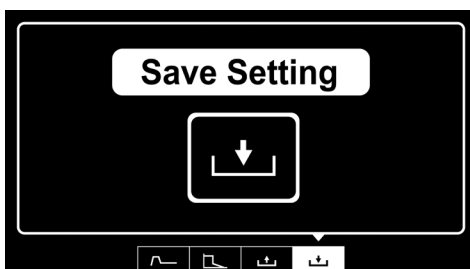
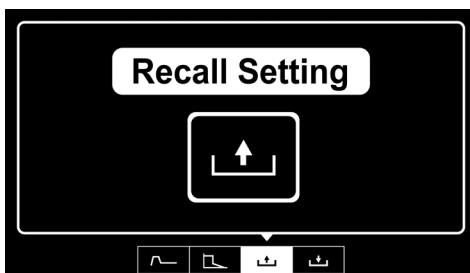
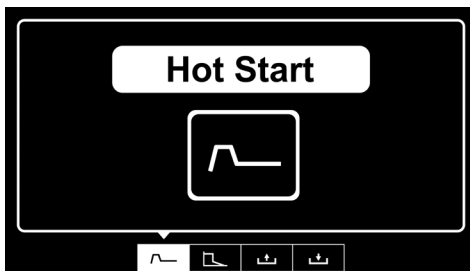

Note: The initial settings may need to be adjusted after stopping and carefully inspecting the weld. Proper welding takes experience.

WARNING! TO PREVENT SERIOUS INJURY: Protective gear must be worn when using the Welder; minimum shade number 10 full face shield (or welding mask), ear protection, welding gloves, sleeves and apron, NIOSH-approved respirator, and fire resistant work clothes without pockets should be worn when welding. Light from the arc can cause permanent damage to the eyes and skin. Do not breathe arc fumes.

After practice welding on scrap, stop, and check your progress. Perform Strike Test according to Strike Test on page 34. After making any necessary adjustments, continue to weld while carefully following the DUTY CYCLE guidelines as explained on page 29.

8. Place the bare metal end of the Stick Electrode (sold separately) inside the jaws of the Electrode Holder.
9. Stroke the workpiece lightly to ignite the arc. Tips for igniting the arc:
 - a. Tap the surface with the Electrode.
 - b. Stroke the surface with the Electrode.
 - c. Strike the surface like a match with the Electrode.
10. After the arc ignites:
 - a. Lift the Electrode off workpiece the same distance as the diameter of the bare metal end.
 - b. Tilt Electrode back 10 to 20 degrees.
 - c. Drag Electrode to the back end of the weld puddle to deposit material as needed.
11. When finished welding; lift the Electrode from the workpiece, then set Electrode Holder down on nonconductive, nonflammable surface away from any grounded objects.
12. Turn the Power Switch OFF.
13. To prevent accidents, after use:
 - Allow Welder to cool down.
 - Unplug Welder's power cord from outlet.
 - Remove Ground Clamp.
 - Disconnect Electrode Holder and Ground Cables.
14. Clean, then store Welder and its accessories indoors out of children's reach.

Welding Tips

A good way to test welding technique is to examine a weld's appearance after it has cooled and the slag has been removed. Then, better welding can be learned by adjusting your weld technique to remedy any problems found.

NOTICE: TIG welding is a complicated process, requiring experience and skill to achieve successful results. Training beyond the scope of this manual is required to TIG weld properly.

After practice welding a couple of welding beads, STOP and examine your weld using the following guidelines.

Strike Test

A test weld on a **PIECE OF SCRAP** can be tested by using the following procedure. **WEAR ANSI-APPROVED SAFETY GOGGLES DURING THIS PROCEDURE.**

WARNING! This test **WILL** damage the weld it is performed on. This test is **ONLY** an indicator of weld technique and is not intended to test working welds.

1. After two scraps have been welded together and the weld has cooled, clamp one scrap in a sturdy vise.
2. Stay clear from underneath while you strike the opposite scrap with a heavy hammer, preferably a dead-blow hammer.
3. A **GOOD WELD** will deform but not break, as shown on top. A **POOR WELD** will be brittle and snap at the weld, as shown on bottom.

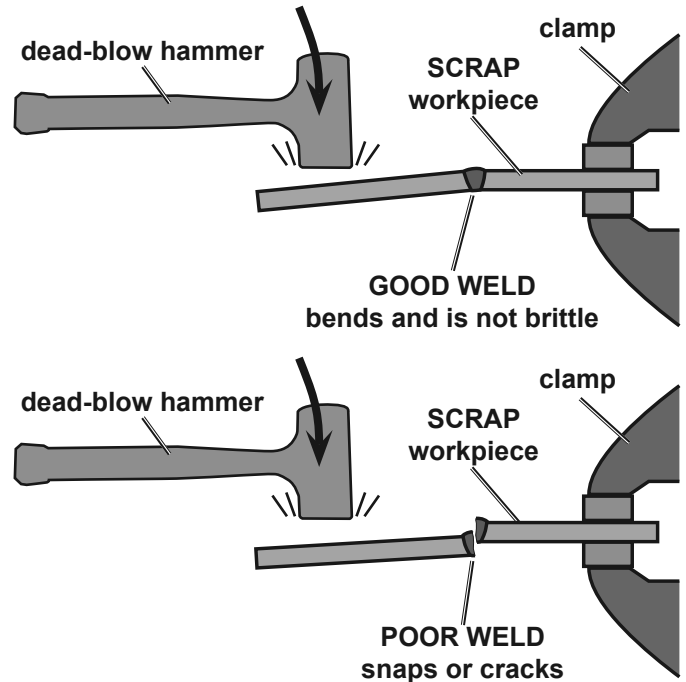

Cleaning the Weld

⚠ WARNING



TO PREVENT SERIOUS INJURY: Continue to wear ANSI-approved safety goggles and protective wear when cleaning a weld. Sparks or chips may fly when cleaning.

1. A weld from flux-cored wire welding or stick welding will be covered by slag. Use a chipping hammer to knock this off. **Be careful not to damage the weld or base material.**
2. Use a wire brush to further clean the weld or use an angle grinder (sold separately) to shape the weld.

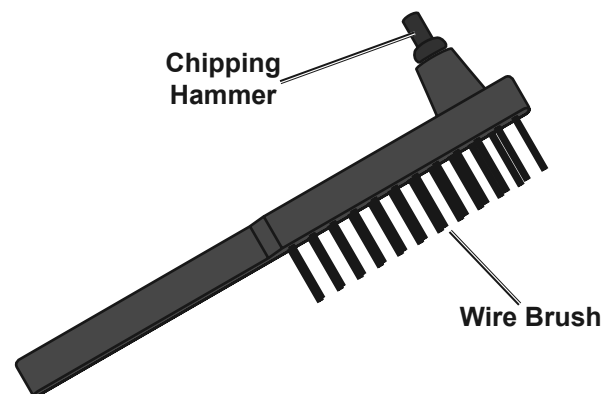

Wire Weld Diagnosis—Workpiece Heat Control / Weld Penetration

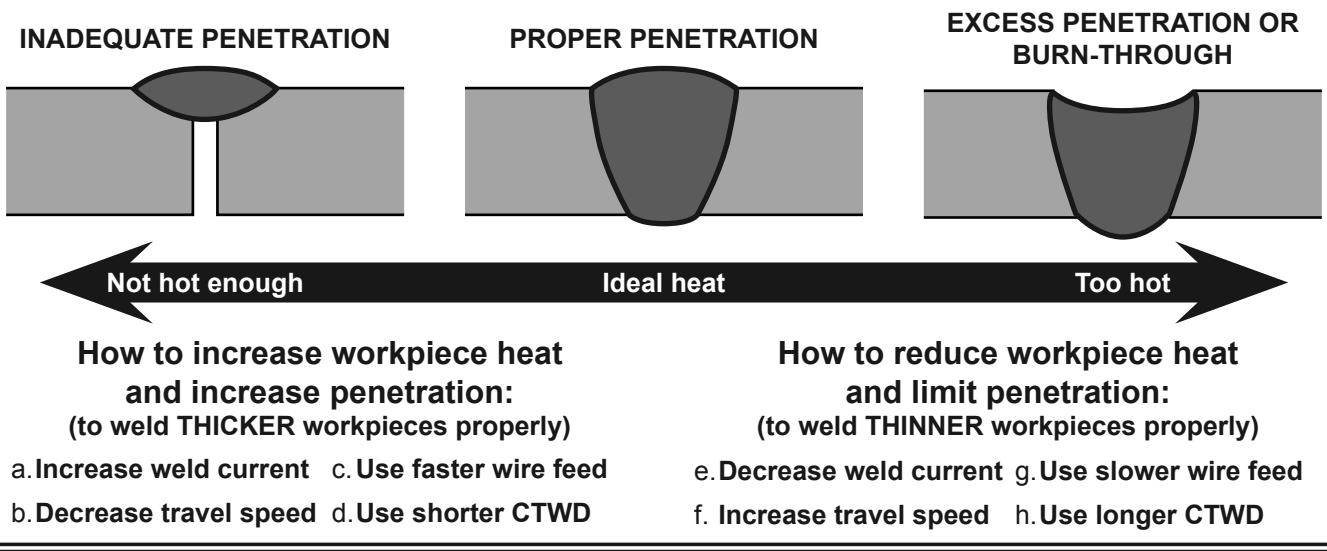

Example Wire Weld Diagrams

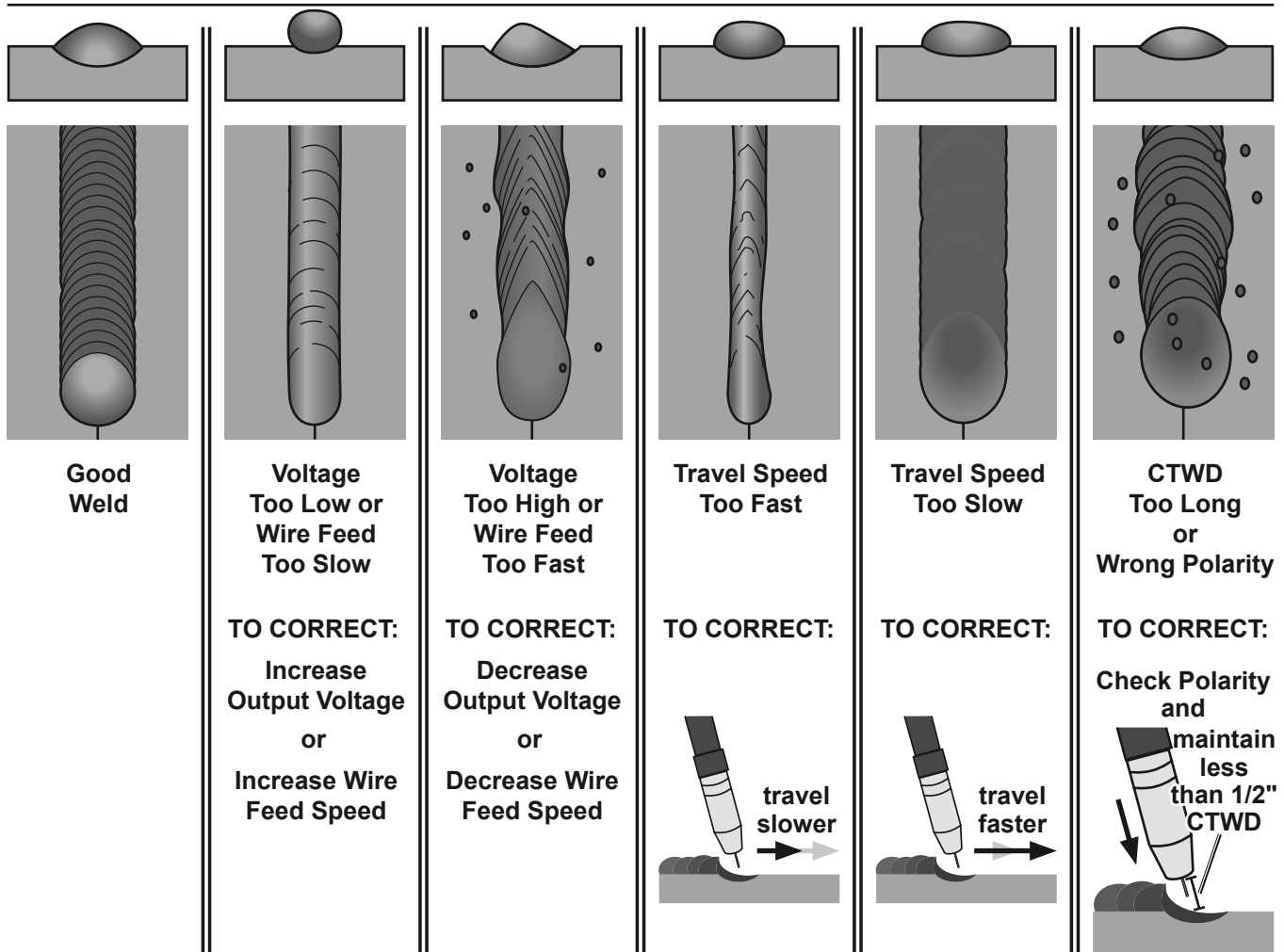

SAFETY

CONTROLS

WIRE

TIG / STICK

WELDING TIPS

MAINTENANCE

Wire Weld Penetration (Workpiece Heat Control)

SAFETY

CONTROLS

WIRE

EXCESS PENETRATION OR BURN-THROUGH
Weld droops on top and underneath, or falls through entirely, making a hole.

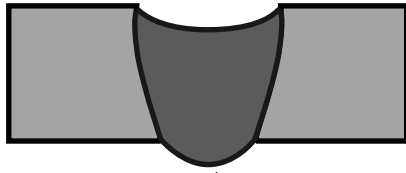

PROPER PENETRATION
Weld is visible underneath and bulges slightly on top.

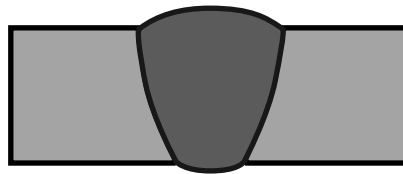

PROFILE VIEWS

INADEQUATE PENETRATION
Weld does not penetrate the joint fully, just on the surface.

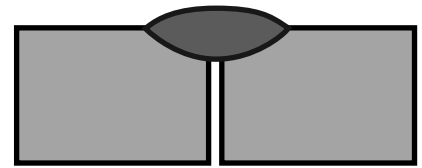

POSSIBLE CAUSES AND SOLUTIONS

1. **Workpiece overheating:**
Reduce wire feed speed.
Decrease weld current.
2. **Travel speed too slow:**
Increase travel speed and ensure that travel speed is kept steady.
3. **Excessive material at weld:**
Reduce wire feed speed.

POSSIBLE CAUSES AND SOLUTIONS

4. **Incorrect welding technique:**
Maintain 1/2" or less CTWD.
Keep arc on leading edge of weld puddle.
Hold MIG Gun at proper angles.
5. **Insufficient weld heat:**
Reduce travel speed.
Increase weld current.
6. **Workpieces too thick/close:**
Bevel thick workpieces, allow slight gap, and weld in several passes.
7. **Insufficient weld material:**
Increase wire feed speed.

Bend at Joint

PROFILE VIEW

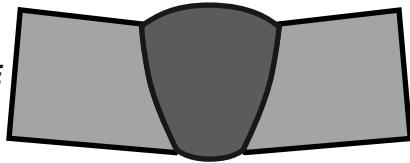

POSSIBLE CAUSES AND SOLUTIONS

1. **Improper clamping:**
Clamp workpieces securely.
Make tack welds to hold workpieces.
2. **Excessive heat:**
Weld a small portion and allow to cool before proceeding.
Increase travel speed.
Reduce wire feed speed.

Weld Not Adhering Properly

Gaps present between weld and previous bead or between weld and workpiece. See areas below.

PROFILE VIEW

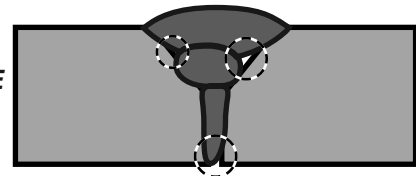

POSSIBLE CAUSES AND SOLUTIONS

1. **Incorrect welding technique:**
Place stringer bead at correct place in joint.
Adjust workpiece position or weld angle to permit proper welding to bottom of piece.
Pause briefly at sides during weave bead.
Keep arc on leading edge of weld puddle.
Hold MIG Gun at proper angles.
2. **Insufficient weld heat:**
Increase current.
Increase wire feed speed.
3. **Dirty workpiece:**
Clean workpiece down to bare metal.
4. **Insufficient weld material:**
Increase wire feed speed.
5. **Workpiece gap too narrow:**
Widen groove or increase bevel.

Coat of Slag Over Weld

TOP VIEW



PARTIALLY CHIPPED AWAY TO SHOW WELD

Slag is a necessary part of a flux-cored wire weld. It shields the weld from impurities. Clean off the slag with a Chipping Hammer and Wire Brush after welding.

Gas-shielded MIG welds are protected by the shielding gas and do not need slag to protect them.

TIG / STICK

WELDING TIPS

MAINTENANCE

Wire Weld–Porosity

Small cavities or holes in the bead.

TOP
VIEW

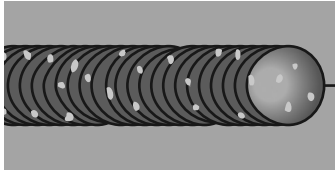

POSSIBLE CAUSES AND SOLUTIONS

1. **Incorrect polarity:**
Check that polarity is set correctly for type of welding.
2. **Insufficient shielding gas (MIG only):**
Increase flow of gas.
Clean nozzle.
Maintain proper CTWD.
3. **Incorrect shielding gas (MIG only):**
Use shielding gas recommended by wire supplier.
4. **Dirty workpiece or welding wire:**
Clean workpiece down to bare metal.
Make certain that wire is clean and free from oil, coatings, and other residues.
5. **Inconsistent travel speed:**
Maintain steady travel speed.
6. **CTWD too long:**
Reduce CTWD.

Wire Weld–Excessive Spatter

Fine spatter is normal.
Spatter that is grainy and large is a problem.

TOP
VIEW

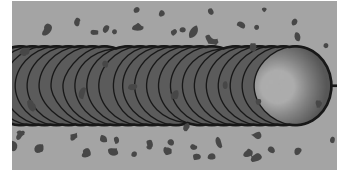

POSSIBLE CAUSES AND SOLUTIONS

1. **Dirty workpiece or welding wire:**
Clean workpiece down to bare metal.
Make certain that wire is clean and free from oil, coatings, and other residues.
2. **Incorrect polarity:**
Check that polarity is set correctly for type of welding.
3. **Insufficient shielding gas (MIG only):**
Increase flow of gas.
Clean nozzle.
Maintain proper CTWD.
4. **Wire feeding too fast:**
Reduce wire feed speed.
5. **CTWD too long:**
Reduce CTWD.

Wire Weld–Crooked/Wavy Bead

TOP
VIEW

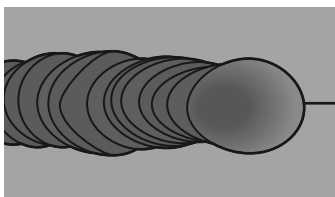

POSSIBLE CAUSES AND SOLUTIONS

1. **Inaccurate welding:**
Use two hands or rest hand on steady surface.
2. **Inconsistent travel speed:**
Maintain steady travel speed.
3. **CTWD too long:**
Reduce CTWD.

Wire Weld–Burn-Through

Base material melts away,
leaving a hole in the weld.

TOP
VIEW

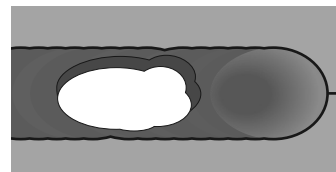

POSSIBLE CAUSES AND SOLUTIONS

1. **Workpiece overheating:**
Reduce current and/or wire feed speed.
2. **Travel speed too slow:**
Increase travel speed and ensure that travel speed is kept steady.
3. **Excessive material at weld:**
Reduce wire feed speed.

SAFETY

CONTROLS

WIRE

TIG / STICK

WELDING TIPS

MAINTENANCE

Stick Weld Diagnosis—Workpiece Heat Control / Weld Penetration

SAFETY

INADEQUATE PENETRATION

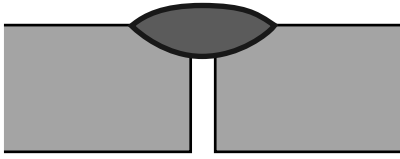

PROPER PENETRATION

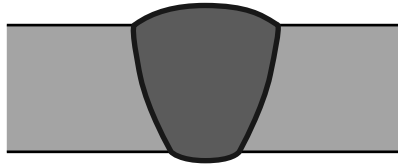

EXCESS PENETRATION OR BURN-THROUGH

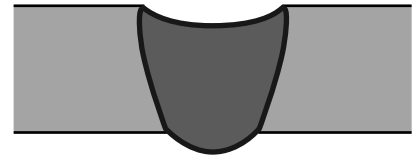

Not hot enough

Ideal heat

Too hot

How to increase workpiece heat and increase penetration:
(to weld **THICKER** workpieces properly)

- a. Increase current. b. Weld more slowly.

How to reduce workpiece heat and limit penetration:
(to weld **THINNER** workpieces properly)

- c. Decrease current. d. Weld more quickly.

CONTROLS

Example Stick Weld Diagrams

WIRE

CLEAN WELDS FIRST!

Stick welds will have a coat of slag over them until cleaned.

Good Weld	Current Too Low	Current Too High	Weld Speed Too Fast	Weld Speed Too Slow	Arc Length Too Short	Arc Length Too Long
	TO CORRECT: Increase the current	TO CORRECT: Decrease the current	TO CORRECT: Weld slower	TO CORRECT: Weld faster	TO CORRECT: Increase distance	TO CORRECT: Decrease distance

TIG / STICK

WELDING TIPS

MAINTENANCE

Stick Weld Penetration (Workpiece Heat Control)

EXCESS PENETRATION OR BURN-THROUGH

Weld droops on top and underneath or falls through entirely, making a hole.

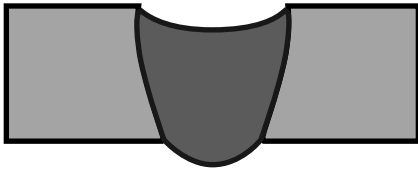

PROPER PENETRATION

Weld is visible underneath and bulges slightly on top.

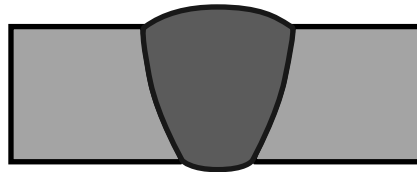

INADEQUATE PENETRATION

Weld does not contact the joint fully, just on the surface.

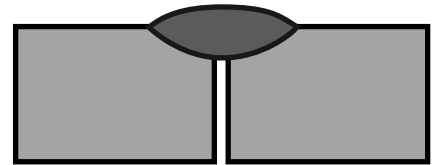

PROFILE VIEWS

POSSIBLE CAUSES AND SOLUTIONS FOR EXCESS PENETRATION OR BURN-THROUGH

1. **Workpiece overheating:**
Reduce current.
2. **Welding speed too slow:**
Increase welding speed and ensure that welding speed is kept steady.

POSSIBLE CAUSES AND SOLUTIONS FOR INADEQUATE PENETRATION

1. **Incorrect welding technique:**
Keep arc on leading edge of weld puddle. Hold torch at proper angles.
2. **Insufficient weld heat:**
Slow down so fill material has time to melt into the weld location. Increase current.
3. **Workpieces too thick/close:**
Bevel thick workpieces, allow slight gap, and weld in several passes.
4. **Insufficient weld material:**
Increase amount of fill material.

Stick Weld—Weld Not Adhering Properly

Gaps present between weld and previous bead or between weld and workpiece. See areas below.

POSSIBLE CAUSES AND SOLUTIONS

PROFILE VIEW

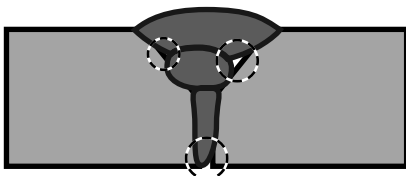

1. **Incorrect welding technique:**
Place stringer bead at correct place in joint. Adjust workpiece position or weld angle to permit proper welding to bottom of piece. Keep arc on leading edge of weld puddle. Hold Electrode and fill material at proper angles.
2. **Insufficient weld heat:**
Increase current.
3. **Dirty workpiece:**
Clean workpiece down to bare metal.
4. **Insufficient weld material:**
Increase amount of fill material.
5. **Distance between workpieces too large:**
Decrease distance and increase bevel.

Stick Weld—Bend at Joint

POSSIBLE CAUSES AND SOLUTIONS

PROFILE VIEW

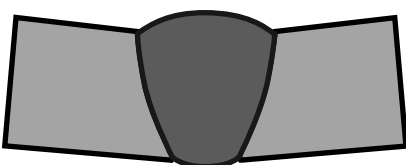

1. **Improper clamping:**
Clamp workpieces securely. Make tack welds to hold workpieces.
2. **Excessive heat:**
Weld a small portion and allow to cool before proceeding. Increase weld speed.

Stick Weld—Coat of Slag Over Weld

TOP
VIEW

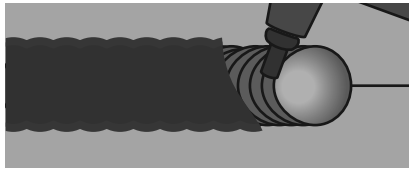

PARTIALLY CHIPPED AWAY TO SHOW WELD

Slag is a necessary part of a stick weld. It shields the weld from impurities. Clean off the slag with the Chipping Hammer and Wire Brush after welding.

Stick Weld—Porosity — Small cavities or holes in the bead.

POSSIBLE CAUSES AND SOLUTIONS

TOP
VIEW

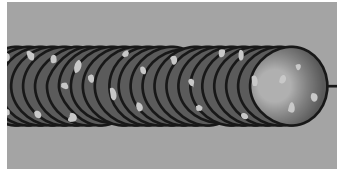

1. **Dirty workpiece or fill material:**
Clean workpiece down to bare metal.
Make certain that fill material and Electrode are clean and free from oil, coatings, and other residues.
2. **Inconsistent welding speed:**
Maintain steady weld speed.

Stick Weld—Crooked/Wavy Bead

POSSIBLE CAUSES AND SOLUTIONS

TOP
VIEW

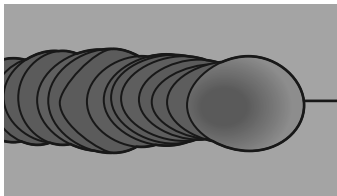

1. **Inaccurate welding:**
Use two hands or rest hand on steady surface.
2. **Inconsistent welding speed:**
Maintain steady weld speed.

Stick Weld—Excessive Spatter

POSSIBLE CAUSES AND SOLUTIONS

TOP
VIEW

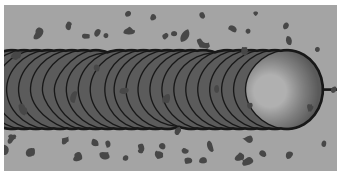

Fine spatter is normal. Spatter that is grainy and large is a problem.

Dirty workpiece or fill material:
Clean workpiece down to bare metal.
Make certain that fill material and Electrode are clean and free from oil, coatings, and other residues.

Stick Weld—Burn-Through — Base material melts away, leaving a hole in the weld.

POSSIBLE CAUSES AND SOLUTIONS

TOP
VIEW

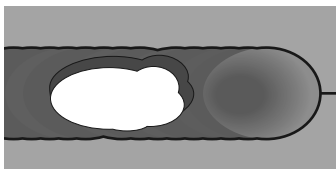

1. **Workpiece overheating:**
Reduce current.
2. **Welding speed too slow:**
Increase welding speed and ensure that welding speed is kept steady.
3. **Excessive material at weld:**
Reduce amount of fill material.

!WARNING



TO PREVENT SERIOUS INJURY, FIRE AND BURNS:

Unplug the Welder, rest the tool on a heat-proof, electrically non-conductive surface, and allow all parts of the Welder to cool thoroughly before service.

1. **BEFORE EACH USE**, inspect the general condition of the Welder. Check for:
 - loose hardware
 - misalignment or binding of moving parts
 - damaged cord/electrical wiring
 - frayed or damaged cables
 - cracked or broken parts
 - any other condition that may affect its safe operation.
2. **PERIODICALLY**, have a qualified technician remove the Rear Panel and use compressed air to blow out all dust from the interior.
3. **AFTER EVERY USE**, store in a clean and dry location.
4. **For optimal MIG/Flux-Cored wire weld quality, clean and inspect the MIG Gun Contact Tip and Nozzle before each use, as explained below.**

MIG Gun Nozzle and Contact Tip Inspection and Cleaning

1. **Make sure that the entire MIG Gun is completely cool and that the Power Cord is unplugged from the electrical outlet before proceeding.**
2. Pull the Nozzle to remove it.
3. Scrub the interior of the Nozzle clean with a wire brush.
4. Examine the end of the Nozzle. The end should be flat and even. If the end is uneven, chipped, melted, cracked, or otherwise damaged, the Nozzle will adversely effect the weld and should be replaced.
5. Unscrew the Contact Tip counterclockwise and slide it off the welding wire to remove.
6. Scrub the outside of the Tip clean with a wire brush. Clean out the inside of the tip with a tip cleaner (sold separately). Check that the Tip is the proper type for the wire size used.
7. Examine the shape of the hole at the end of the Contact Tip. It should be an even circle; it should not be oblong or have any bulges in it.
8. If any problems are noted, replace the Contact Tip. Select a new Tip of the correct size for the welding wire used.
9. Reinstall the Tip and securely reinstall the Nozzle as well.

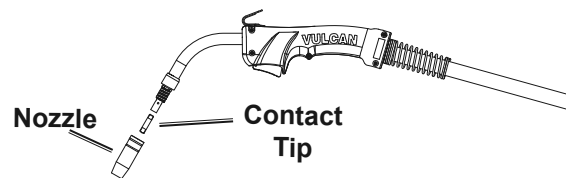

Replacing the LCD Screen Cover

1. Carefully pry frame off of Display (17) by inserting flathead screwdriver (sold separately) into one of the side slots.
2. Insert a new Screen Cover (18) into Screen Frame (19) with the gap facing downward.

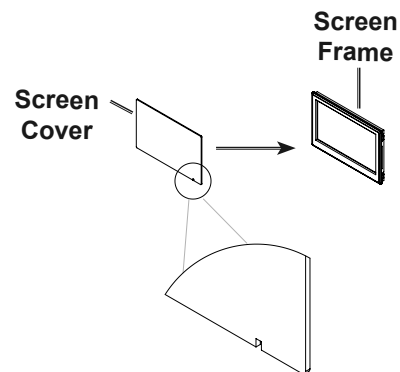
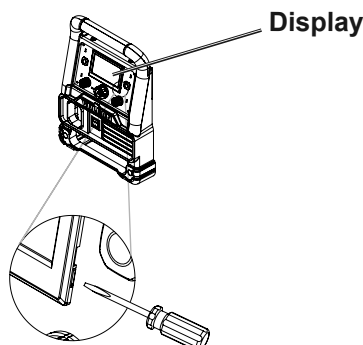

3. Insert frame back into slot on Display with the top end being placed in first.

Troubleshooting—MIG/Flux-Cored Welding

IMPORTANT!

Be **CERTAIN** to shut off the Welder, disconnect it from power, and discharge the MIG Gun to ground before adjusting, cleaning, or repairing the unit.

Problem	Possible Causes	Likely Solutions
Wire Feed Motor Runs but Wire Does Not Feed Properly	<ol style="list-style-type: none"> 1. Insufficient wire feed pressure. 2. Incorrect wire feed roller size. 3. Damaged MIG Gun, cable, or liner assembly. 4. Feed Tensioner is too tight. 	<ol style="list-style-type: none"> 1. Increase wire feed pressure properly. Follow step 27 on page 17. 2. Flip roll to correct size. Follow the Feed Roller instructions on page 12. 3. Have a qualified technician inspect these parts and replace as necessary. 4. Loosen Feed Tensioner so it applies only enough pressure to prevent continued spinning after the Gun Trigger is released.
Wire Creates a Bird's Nest During Operation	<ol style="list-style-type: none"> 1. Excess wire feed pressure. 2. Incorrect Contact Tip size. 3. MIG Gun Cable Connector not fully inserted into Wire Feed mechanism. 4. Damaged liner. 	<ol style="list-style-type: none"> 1. Adjust wire feed pressure properly. Follow step 27 on page 17. 2. Replace with the proper tip for wire used. 3. Insert Gun Cable Connector properly. Follow steps 13 and 14 on page 13. 4. Have a qualified technician inspect and repair/replace as necessary.
Wire Stops During Welding	<ol style="list-style-type: none"> 1. Gun cable is severely bent and Wire Feed mechanism cannot feed wire. 2. Gun liner is clogged or worn. 3. Gun liner is too small for welding wire being used. 4. Wire is tangled on the spool. 5. Wire is not making contact with Feed Rollers. 6. Feed Roller is not making enough contact with wire or is crushing flux-cored wire. 	<ol style="list-style-type: none"> 1. Straighten Gun cable. 2. Check gun liner for obstruction. Replace if necessary. 3. Check that gun liner is correct size for wire. 4. Check wire for cross winding or tangled spool. 5. Check Feed Rollers and ensure correct groove for wire diameter is being used. 6. Check Feed Tensioner and ensure it is set properly.
Welding Arc Not Stable	<ol style="list-style-type: none"> 1. Wire not feeding properly. 2. Incorrect Contact Tip or liner size or excessive wear. 3. Incorrect wire feed speed. 4. Loose MIG Gun cable or ground cable. 5. Damaged MIG Gun or loose connection within Gun. 6. Incorrect polarity for process being run. 7. Gas coverage may be insufficient or too high. 8. Poor connection with workpiece. 	<ol style="list-style-type: none"> 1. See first Troubleshooting section above. 2. Replace with the proper tip or liner size for wire used. 3. Adjust wire feed speed to achieve a more stable arc. 4. Check to ensure that all connections are tight. 5. Have a qualified technician inspect and repair/replace as necessary. 6. Ensure polarity is correct for operation: DCEP for MIG welding and DCEN for Flux-Cored self-shielded welding. 7. Ensure gas flow rate is set according to Settings Chart. Make sure MIG Gun Cable Connector is fully inserted into Wire Feed mechanism with no O-Rings exposed. 8. Check the ground clamp connection to the workpiece and machine. Ensure the MIG Gun is properly secured.
Weak Arc Strength	<ol style="list-style-type: none"> 1. Incorrect line voltage. 2. Improper gauge or length of cord. 3. Not enough current. 	<ol style="list-style-type: none"> 1. Check the line voltage and, if insufficient, have a licensed electrician remedy the situation. 2. Do not use an extension cord on this Welder. Use only one of the supplied power cords for this Welder or an identical replacement cord. 3. Switch current to proper setting for metal thickness.



Follow all safety precautions whenever diagnosing or servicing the equipment.

SAFETY

CONTROLS

WIRE

TIG / STICK

WELDING TIPS

MAINTENANCE

Problem	Possible Causes	Likely Solutions
Welder Does Not Function When Switched On	<ol style="list-style-type: none"> 1. Tripped thermal protection device. 2. Circuit supplies insufficient input voltage or amperage. 3. Faulty or improperly connected Trigger. 4. Machine is in low- or over-voltage protection. 5. Machine is in the incorrect mode. 	<ol style="list-style-type: none"> 1. If a warning screen appears in the LCD Display window, Welder may have overheated and shut down. Stop and wait with the Power Switch ON for the Welder to cool. The Welder automatically returns to service after cooling off. Reduce duration or frequency of welding periods to help reduce wear on the Welder. Refer to <i>Duty Cycle (Duration of Use)</i> on page 19. 2. Verify that the circuit is designed to supply the required input voltage and amperage as detailed on the Specifications table. If a warning screen appears in the LCD Display window, check the input voltage to ensure it is within specified range. 3. Ensure the gun connection is properly seated on machine. Qualified technician must check and secure/replace Trigger. 4. Check input voltage and ensure it falls within the specified range. If input voltage is correct, press Reset Button on back of machine. 5. Ensure the correct process has been selected.
LCD Display Does Not Light When Welder is Switched On	<ol style="list-style-type: none"> 1. Unit is not connected to outlet properly. 2. Outlet is unpowered. 3. Plug does not have correct rating. 4. Circuit breaker has tripped due to high input amperage. 5. Input Power Cord is not seated properly. 	<ol style="list-style-type: none"> 1. Verify the voltage at the outlet and the connection to the outlet. 2. Check circuit breaker/GFCI devices; if any are tripped, determine and remedy cause before resetting. 3. Make sure installed plug is correct rating. See <i>Specifications</i> on page 7. 4. Press Reset Button on back of machine to reset circuit breaker. 5. Ensure the twist lock input Power Cord is fully secured.
Wire Feeds, but Arc Does Not Ignite	<ol style="list-style-type: none"> 1. Improper ground connection. 2. Improperly sized Contact Tip. 3. Excessively worn Contact Tip. 4. Dirty Contact Tip. 	<ol style="list-style-type: none"> 1. Make certain that the workpiece is contacted properly by the Ground Clamp and that the workpiece is properly cleaned near the ground clamp and the welding location. 2. Verify that Contact Tip is the proper size for welding wire. If needed, replace Contact Tip with proper size and type. 3. Check that the hole in the tip is not deformed or enlarged. If needed, replace Contact Tip with proper size and type. 4. Properly clean Contact Tip.
Porosity in the Weld Metal	<ol style="list-style-type: none"> 1. Shielding gas bottle is empty. 2. Not enough or too much shielding gas. 3. Dirty workpiece. 4. Gun is being used too far away from workpiece. 5. Polarity is incorrect for the application. 6. Dirty welding wire is introducing contamination into the weld. 	<ol style="list-style-type: none"> 1. Check gas bottle and replenish as necessary. 2. Check gas regulator to ensure proper flow. 3. Clean workpiece down to bare metal. 4. Check CTWD (contact tip to work distance) for the proper procedure. 5. Check the polarity and ensure it is DCEP for MIG and DCEN for Flux-Cored. 6. Make certain that welding wire is clean and free of rust and residues.



Follow all safety precautions whenever diagnosing or servicing the equipment.

SAFETY

CONTROLS

WIRE

TIG / STICK

WELDING TIPS

MAINTENANCE

Troubleshooting – TIG/Stick Welding

IMPORTANT!

Be **CERTAIN** to shut off the Welder, disconnect it from power, and discharge the electrode to ground before adjusting, cleaning, or repairing the unit.

Problem	Possible Causes	Likely Solutions
Welder Does Not Function When Switched On	<ol style="list-style-type: none"> 1. Tripped thermal protection device. 2. Faulty or improperly connected Trigger. 3. Ground Clamp not attached to workpiece. 4. Shielding Gas not connected. 	<ol style="list-style-type: none"> 1. Reduce duration or frequency of welding periods to help reduce wear on the welder. Refer to <i>Duty Cycle (Duration of Use)</i> on page 29. 2. Qualified technician must check and secure/replace Trigger. 3. Attach Ground Clamp to workpiece. 4. Connect shielding gas to Welder.
LCD Display Does Not Light When Welder is Switched On	<ol style="list-style-type: none"> 1. Unit is not connected to outlet properly. 2. Outlet is unpowered. 	<ol style="list-style-type: none"> 1. Verify the voltage at the outlet and the connection to the outlet. 2. Check circuit breaker/GFCI devices; if any are tripped, determine and remedy cause before resetting. Verify that the circuit is designed to supply the required input amperage as detailed in <i>Specifications</i> on page 7.
Weak Arc Strength	<ol style="list-style-type: none"> 1. Incorrect line voltage. 2. Improper gauge or length of cord. 	<ol style="list-style-type: none"> 1. Check the line voltage and, if insufficient, have a licensed electrician remedy the situation. 2. Do not use an extension cord on this Welder. Use only one of the supplied power cords for this Welder or an identical replacement cord.
Welding Arc Not Stable.	<ol style="list-style-type: none"> 1. Loose electrode cable or ground cable. 2. Damaged electrode holder or loose connection within electrode holder. 3. Adjust current setting. 4. Shielding gas getting low. 	<ol style="list-style-type: none"> 1. Check to ensure that all connections are tight. 2. Have a qualified technician inspect and repair/replace as necessary. 3. Make sure setting matches recommended setting on chart. 4. Replace shielding gas cylinder.
 <p>Follow all safety precautions whenever diagnosing or servicing the equipment.</p>		

SAFETY

CONTROLS

WIRE

TIG / STICK

WELDING TIPS

MAINTENANCE

PLEASE READ THE FOLLOWING CAREFULLY

THE MANUFACTURER AND/OR DISTRIBUTOR HAS PROVIDED THE PARTS LIST AND ASSEMBLY DIAGRAM IN THIS MANUAL AS A REFERENCE TOOL ONLY. NEITHER THE MANUFACTURER OR DISTRIBUTOR MAKES ANY REPRESENTATION OR WARRANTY OF ANY KIND TO THE BUYER THAT HE OR SHE IS QUALIFIED TO MAKE ANY REPAIRS TO THE PRODUCT, OR THAT HE OR SHE IS QUALIFIED TO REPLACE ANY PARTS OF THE PRODUCT. IN FACT, THE MANUFACTURER AND/OR DISTRIBUTOR EXPRESSLY STATES THAT ALL REPAIRS AND PARTS REPLACEMENTS SHOULD BE UNDERTAKEN BY CERTIFIED AND LICENSED TECHNICIANS, AND NOT BY THE BUYER. THE BUYER ASSUMES ALL RISK AND LIABILITY ARISING OUT OF HIS OR HER REPAIRS TO THE ORIGINAL PRODUCT OR REPLACEMENT PARTS THERETO, OR ARISING OUT OF HIS OR HER INSTALLATION OF REPLACEMENT PARTS THERETO.

Parts List

Part	Description	Qty
1	Housing	1
2	Handle Base	1
3	Handle Cover	1
4	Hinge	2
5	Hinge Pin	2
6	Door	1
7	Latch	1
8	Panel	1
9	PFC Inductor	1
10	Spool	1
11	Remote Control PCB	1
12	Wire Feed Mechanism	1
13	Foot Pedal Connector	1
14	Air Connector	1
15	Cover	1
16	Display PCB	1
17	Display	1
18	Screen Cover	1
19	Screen Frame	1
20	MIG Welding Gun	1
21	Front Handle Cover	1
22	Front Panel	1
23	Control Panel	1
24	Side Knob	2
25	Knob	1
26	Storage Door	1
27	Switch	1
28	Air Connector	1
29	Air Fitting	1
30	Quick Connector	2
31	Ground Clamp	1
32	Electrode Holder	1

Part	Description	Qty
33	Wire Feed Connector	1
34	Air Connector	1
35	Output Inductor	1
36	Air Connector	3
37	Solenoid Valve	2
38	Base	1
39	Insulating Board	1
40	Main PCB	1
41	Control PCB	1
42	Fast Recovery Diode	6
43	Air Duct	1
44	Rectifier Radiator Bracket	1
45	Rectifier Radiator	1
46	Fan	1
47	Transformer	1
48	IGBT	2
49	Heatsink	1
50	Fast Recovery Diode	2
51	IGBT Radiator Bracket	1
52	IGBT Radiator	1
53	Bridge Rectifier	2
54	IGBT	4
55	IGBT Radiator	2
56	Fan	1
57	Threaded Y-connector	1
58	120VAC Power Cord	1
59	Rear Panel	1
60	Rear Handle Cover	1
61	Power Connector	1
62	Overload Protector	1
63	Rear Panel	1
64	240VAC Power Cord	1

Record Product's Serial Number Here: _____

Note: If product has no serial number, record month and year of purchase instead.

Note: Some parts are listed and shown for illustration purposes only, and are not available individually as replacement parts.

Assembly Diagram

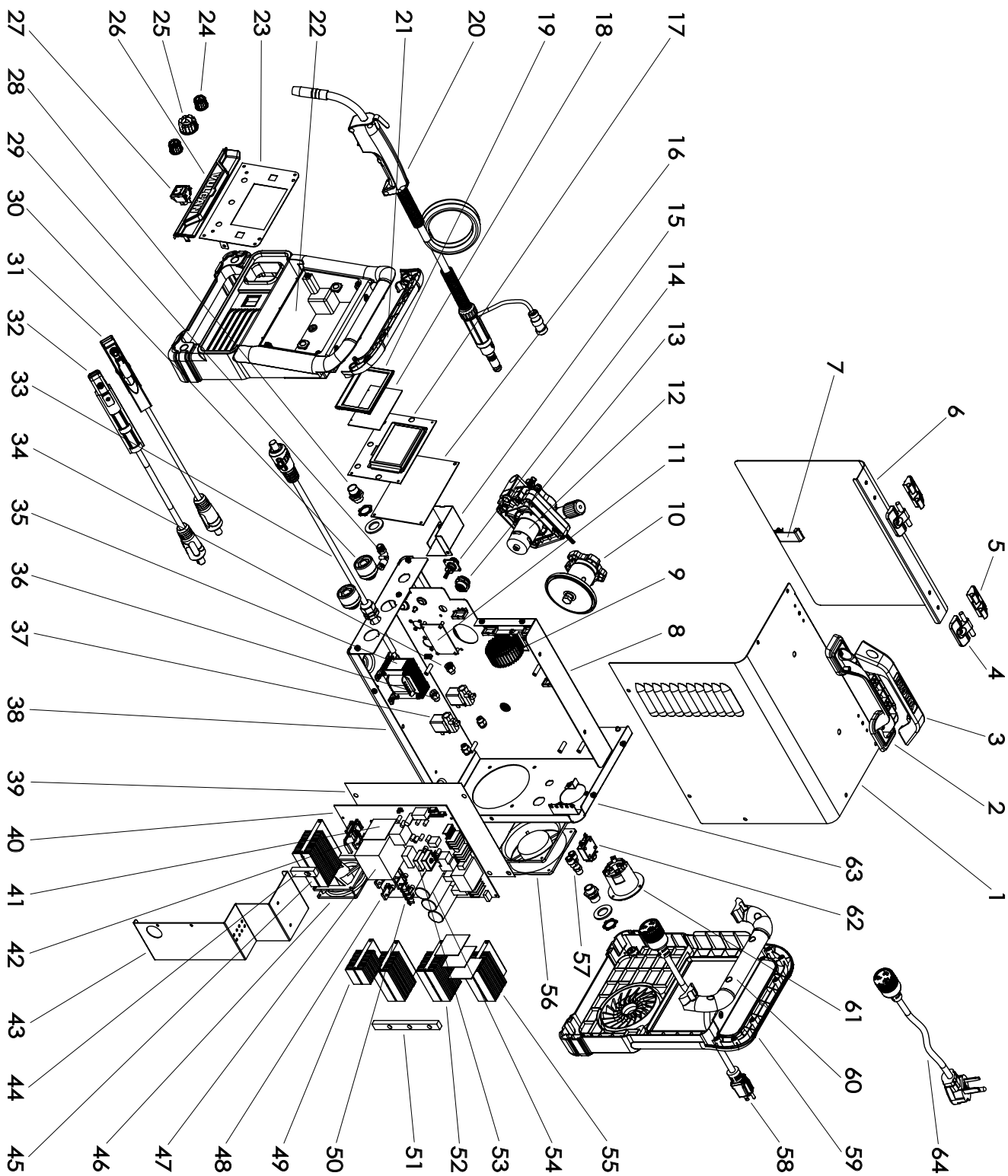

SAFETY

CONTROLS

WIRE

TOOLS / GIL

SPLITTING

MAINTENANCE

Limited 90 Day Warranty

Harbor Freight Tools Co. makes every effort to assure that its products meet high quality and durability standards, and warrants to the original purchaser that this product is free from defects in materials and workmanship for the period of 90 days from the date of purchase. This warranty does not apply to damage due directly or indirectly, to misuse, abuse, negligence or accidents, repairs or alterations outside our facilities, criminal activity, improper installation, normal wear and tear, or to lack of maintenance. We shall in no event be liable for death, injuries to persons or property, or for incidental, contingent, special or consequential damages arising from the use of our product. Some states do not allow the exclusion or limitation of incidental or consequential damages, so the above limitation of exclusion may not apply to you. THIS WARRANTY IS EXPRESSLY IN LIEU OF ALL OTHER WARRANTIES, EXPRESS OR IMPLIED, INCLUDING THE WARRANTIES OF MERCHANTABILITY AND FITNESS.

To take advantage of this warranty, the product or part must be returned to us with transportation charges prepaid. Proof of purchase date and an explanation of the complaint must accompany the merchandise. If our inspection verifies the defect, we will either repair or replace the product at our election or we may elect to refund the purchase price if we cannot readily and quickly provide you with a replacement. We will return repaired products at our expense, but if we determine there is no defect, or that the defect resulted from causes not within the scope of our warranty, then you must bear the cost of returning the product.

This warranty gives you specific legal rights and you may also have other rights which vary from state to state.



26541 Agoura Road • Calabasas, CA 91302 • 1-888-866-5797