

Assembly and Operating Manual

LGZ

3-Finger Centric Gripper



Imprint

Copyright:

This manual is protected by copyright. The author is SCHUNK GmbH & Co. KG. All rights reserved. Any reproduction, processing, distribution (making available to third parties), translation or other usage - even excerpts - of the manual is especially prohibited and requires our written approval.

Technical changes:

We reserve the right to make alterations for the purpose of technical improvement.

Document number: 389192

Version: 04.00 | 19/11/2018 | en

© SCHUNK GmbH & Co. KG

All rights reserved.

Dear Customer,

thank you for trusting our products and our family-owned company, the leading technology supplier of robots and production machines.

Our team is always available to answer any questions on this product and other solutions. Ask us questions and challenge us. We will find a solution!

Best regards,

Your SCHUNK team

SCHUNK GmbH & Co. KG
Spann- und Greiftechnik

Bahnhofstr. 106 – 134
D-74348 Lauffen/Neckar

Tel. +49-7133-103-0

Fax +49-7133-103-2399

info@de.schunk.com

schunk.com

Table of contents

1	General	5
1.1	About this manual	5
1.1.1	Presentation of Warning Labels	5
1.1.2	Applicable documents	6
1.1.3	Variants.....	6
1.2	Warranty	6
1.3	Scope of delivery	6
1.4	Accessories	6
1.4.1	Sensors	7
2	Basic safety notes	8
2.1	Intended use.....	8
2.2	Not intended use.....	8
2.3	Constructional changes	8
2.4	Spare parts	8
2.5	Gripper fingers	9
2.6	Ambient conditions and operating conditions	9
2.7	Personnel qualification	9
2.8	Personal protective equipment.....	10
2.9	Notes on safe operation	11
2.10	Transport	11
2.11	Malfunctions.....	11
2.12	Disposal	12
2.13	Fundamental dangers.....	12
2.13.1	Protection during handling and assembly	12
2.13.2	Protection during commissioning and operation	13
2.13.3	Protection against dangerous movements.....	13
2.13.4	Protection against electric shock.....	13
2.14	Notes on particular risks.....	14
3	Technical data	16
4	Assembly	18
4.1	Mechanical connection	18
4.2	Pneumatic connection.....	19
4.3	Sensors	20
4.3.1	Programmable magnetic switch (MMS-P).....	21

5	Troubleshooting	26
5.1	Product is not moving.....	26
5.2	The module does not travel through the entire stroke?	26
5.3	Module opens or closes abruptly?	26
5.4	Gripping force is dropping	27
5.5	Magnetic switch does not work	27
5.6	Product does not achieve the opening and closing times	27
6	Maintenance	28
6.1	Maintenance and care.....	28
7	Translation of original declaration of incorporation	29
8	Annex to Declaration of Incorporation.....	30

1 General

1.1 About this manual

This manual contains important information for a safe and appropriate use of the product.

This manual is an integral part of the product and must be kept accessible for the personnel at all times.

Before starting work, the personnel must have read and understood this operating manual. Prerequisite for safe working is the observance of all safety instructions in this manual.

Illustrations in this manual are provided for basic understanding and may differ from the actual product design.

In addition to these instructions, the documents listed under [Applicable documents](#) [▶ 6] are applicable.

1.1.1 Presentation of Warning Labels

To make risks clear, the following signal words and symbols are used for safety notes.



⚠ DANGER

Danger for persons!

Non-observance will inevitably cause irreversible injury or death.



⚠ WARNING

Dangers for persons!

Non-observance can lead to irreversible injury and even death.



⚠ CAUTION

Dangers for persons!

Non-observance can cause minor injuries.

NOTICE

Material damage!

Information about avoiding material damage.

1.1.2 Applicable documents

- General terms of business*
- Catalog data sheet of the purchased product *
- Assembly and operating manuals of the accessories *

The documents marked with an asterisk (*) can be downloaded on our homepage schunk.com

1.1.3 Variants

This operating manual applies to the following variations:

- LGZ without gripping force maintenance
- LGZ with gripping force maintenance "O.D. gripping" (AS)
- LGZ with gripping force maintenance "I.D. gripping" (IS)

1.2 Warranty

If the product is used as intended, the warranty is valid for 24 months from the ex-works delivery date under the following conditions:

- Observe the specified maintenance and lubrication intervals
- Observe the ambient conditions and operating conditions

Parts touching the workpiece and wear parts are not included in the warranty.

1.3 Scope of delivery

The scope of delivery includes

- 3-finger centric gripper LGZ in the version ordered
- Assembly and Operating Manual
- Accessory pack

1.4 Accessories

The following accessories that are required for the module must be ordered separately:

- Sensors

A wide range of accessories is available for this module.

For information about which accessories can be used with the appropriate product version  catalog.

1.4.1 Sensors

Overview of the compatible sensors

Designation	Type
Programmable magnetic switch with two switching points	MMS-P

- Exact type designation of the compatible sensors see  catalog.
- If you require information on sensor operation, contact your SCHUNK contact person or download information from our homepage. www.schunk.com
- For mounting the sensors, mounting kits are partly necessary.

2 Basic safety notes

2.1 Intended use

The product is designed exclusively for gripping and temporarily holding workpieces or objects.

- The product may only be used within the scope of its technical data, [Technical data](#) [▶ 16].
- When implementing and operating components in safety-related parts of the control systems, the basic safety principles in accordance with DIN EN ISO 13849-2 apply. The proven safety principles in accordance with DIN EN ISO 13849-2 also apply to categories 1, 2, 3 and 4.
- The product is intended for installation in a machine/system. The applicable guidelines must be observed and complied with.
- The product is intended for industrial and industry-oriented use.
- Appropriate use of the product includes compliance with all instructions in this manual.

2.2 Not intended use

It is not intended use if the product is used, for example, as a pressing tool, stamping tool, lifting gear, guide for tools, cutting tool, clamping device or a drilling tool.

- Any utilization that exceeds or differs from the appropriate use is regarded as misuse.

2.3 Constructional changes

Implementation of structural changes

By conversions, changes, and reworking, e.g. additional threads, holes, or safety devices can impair the functioning or safety of the product or damage it.

- Structural changes should only be made with the written approval of SCHUNK.

2.4 Spare parts

Use of unauthorized spare parts

Using unauthorized spare parts can endanger personnel and damage the product or cause it to malfunction.

- Use only original spare parts or spares authorized by SCHUNK.

2.5 Gripper fingers

Requirements for the gripper fingers

Stored energy within the product creates the risk of serious injuries and significant property damage.

- Arrange the gripper fingers in a way that the product reaches either the position "open" or "closed" in a de-energized state.
- Only exchange the gripper fingers when no residual energy remains in the product.
- Make sure that the product and the top jaws are a sufficient size for the application.

2.6 Ambient conditions and operating conditions

Required ambient conditions and operating conditions

Incorrect ambient and operating conditions can make the product unsafe, leading to the risk of serious injuries, considerable material damage and/or a significant reduction to the product's life span.

- Make sure that the product is used only in the context of its defined application parameters, [Technical data](#) [► 16].
- Make sure that the product is a sufficient size for the application.
- Make sure that the environment is free from splash water and vapors as well as from abrasion or processing dust. Exceptions are products that are designed especially for contaminated environments.

2.7 Personnel qualification

Inadequate qualifications of the personnel

If the personnel working with the product is not sufficiently qualified, the result may be serious injuries and significant property damage.

- All work may only be performed by qualified personnel.
- Before working with the product, the personnel must have read and understood the complete assembly and operating manual.
- Observe the national safety regulations and rules and general safety instructions.

The following personal qualifications are necessary for the various activities related to the product:

Trained electrician	Due to their technical training, knowledge and experience, trained electricians are able to work on electrical systems, recognize and avoid possible dangers and know the relevant standards and regulations.
Qualified personnel	Due to its technical training, knowledge and experience, qualified personnel is able to perform the delegated tasks, recognize and avoid possible dangers and knows the relevant standards and regulations.
Instructed person	Instructed persons were instructed by the operator about the delegated tasks and possible dangers due to improper behaviour.
Service personnel of the manufacturer	Due to its technical training, knowledge and experience, service personnel of the manufacturer is able to perform the delegated tasks and to recognize and avoid possible dangers.

2.8 Personal protective equipment

Use of personal protective equipment

Personal protective equipment serves to protect staff against danger which may interfere with their health or safety at work.

- When working on and with the product, observe the occupational health and safety regulations and wear the required personal protective equipment.
- Observe the valid safety and accident prevention regulations.
- Wear protective gloves to guard against sharp edges and corners or rough surfaces.
- Wear heat-resistant protective gloves when handling hot surfaces.
- Wear protective gloves and safety goggles when handling hazardous substances.
- Wear close-fitting protective clothing and also wear long hair in a hairnet when dealing with moving components.

2.9 Notes on safe operation

Incorrect handling of the personnel

Incorrect handling and assembly may impair the product's safety and cause serious injuries and considerable material damage.

- Avoid any manner of working that may interfere with the function and operational safety of the product.
- Use the product as intended.
- Observe the safety notes and assembly instructions.
- Do not expose the product to any corrosive media. This does not apply to products that are designed for special environments.
- Eliminate any malfunction immediately.
- Observe the care and maintenance instructions.
- Observe the current safety, accident prevention and environmental protection regulations regarding the product's application field.

2.10 Transport

Handling during transport

Incorrect handling during transport may impair the product's safety and cause serious injuries and considerable material damage.

- When handling heavy weights, use lifting equipment to lift the product and transport it by appropriate means.
- Secure the product against falling during transportation and handling.
- Stand clear of suspended loads.

2.11 Malfunctions

Behavior in case of malfunctions

- Immediately remove the product from operation and report the malfunction to the responsible departments/persons.
- Order appropriately trained personnel to rectify the malfunction.
- Do not recommission the product until the malfunction has been rectified.
- Test the product after a malfunction to establish whether it still functions properly and no increased risks have arisen.

2.12 Disposal

Handling of disposal

The incorrect handling of disposal may impair the product's safety and cause serious injuries as well as considerable material and environmental harm.

- Follow local regulations on dispatching product components for recycling or proper disposal.

2.13 Fundamental dangers

General

- Observe safety distances.
- Never deactivate safety devices.
- Before commissioning the product, take appropriate protective measures to secure the danger zone.
- Disconnect power sources before installation, modification, maintenance, or calibration. Ensure that no residual energy remains in the system.
- If the energy supply is connected, do not move any parts by hand.
- Do not reach into the open mechanism or movement area of the product during operation.

2.13.1 Protection during handling and assembly

Incorrect handling and assembly

Incorrect handling and assembly may impair the product's safety and cause serious injuries and considerable material damage.

- Have all work carried out by appropriately qualified personnel.
- For all work, secure the product against accidental operation.
- Observe the relevant accident prevention rules.
- Use suitable assembly and transport equipment and take precautions to prevent jamming and crushing.

Incorrect lifting of loads

Falling loads may cause serious injuries and even death.

- Stand clear of suspended loads and do not step into their swiveling range.
- Never move loads without supervision.
- Do not leave suspended loads unattended.

2.13.2 Protection during commissioning and operation

Falling or violently ejected components

Falling and violently ejected components can cause serious injuries and even death.

- Take appropriate protective measures to secure the danger zone.
- Never step into the danger zone during operation.

2.13.3 Protection against dangerous movements

Unexpected movements

Residual energy in the system may cause serious injuries while working with the product.

- Switch off the energy supply, ensure that no residual energy remains and secure against inadvertent reactivation.
- Never rely solely on the response of the monitoring function to avert danger. Until the installed monitors become effective, it must be assumed that the drive movement is faulty, with its action being dependent on the control unit and the current operating condition of the drive. Perform maintenance work, modifications, and attachments outside the danger zone defined by the movement range.
- To avoid accidents and/or material damage, human access to the movement range of the machine must be restricted. Limit/prevent accidental access for people in this area due through technical safety measures. The protective cover and protective fence must be rigid enough to withstand the maximum possible movement energy. EMERGENCY STOP switches must be easily and quickly accessible. Before starting up the machine or automated system, check that the EMERGENCY STOP system is working. Prevent operation of the machine if this protective equipment does not function correctly.

2.13.4 Protection against electric shock

Possible electrostatic energy

Components or assembly groups may become electrostatically charged. When the electrostatic charge is touched, the discharge may trigger a shock reaction leading to injuries.

- The operator must ensure that all components and assembly groups are included in the local potential equalisation in accordance with the applicable regulations.
- While paying attention to the actual conditions of the working environment, the potential equalisation must be implemented by a specialist electrician according to the applicable regulations.
- The effectiveness of the potential equalisation must be verified by executing regular safety measurements.

2.14 Notes on particular risks



⚠ DANGER

Risk of fatal injury from suspended loads!

Falling loads can cause serious injuries and even death.

- Stand clear of suspended loads and do not step within their swiveling range.
- Never move loads without supervision.
- Do not leave suspended loads unattended.
- Wear suitable protective equipment.



⚠ WARNING

Risk of injury from objects falling and being ejected!

Falling and ejected objects during operation can lead to serious injury or death.

- Take appropriate protective measures to secure the danger zone.



⚠ WARNING

Risk of injury due to unexpected movements!

If the power supply is switched on or residual energy remains in the system, components can move unexpectedly and cause serious injuries.

- Before starting any work on the product: Switch off the power supply and secure against restarting.
- Make sure, that no residual energy remains in the system.



⚠ WARNING

Risk of injury from crushing and impacts!

Serious injury could occur during the base jaw procedure and when breaking or loosening the gripper fingers.

- Wear suitable protective equipment.
- Do not reach into the open mechanism or the movement area of the product.

**⚠ WARNING****Risk of injury from sharp edges and corners!**

Sharp edges and corners can cause cuts.

- Use suitable protective equipment.

**⚠ WARNING****Risk of injury due to spring forces!**

Parts are under spring tension on products which clamp using spring force or which have gripping force maintenance. While disassembling components can move unexpectedly and cause serious injuries.

- Disassemble the product cautiously.
- Make sure that no residual energy remains in the system.

**⚠ WARNING****Risk of injury from objects falling during energy supply failure**

Products with a mechanical gripping force maintenance can, during energy supply failure, still move independently in the direction specified by the mechanical gripping force maintenance.

- Secure the end positions of the product with SCHUNK SDV-P pressure maintenance valves.

3 Technical data

Size	16	32	50
Mechanical operating data			
Stroke per jaw [mm]	3	4	7
Weight [kg]			
without gripping force maintenance	0,1	0,32	0,95
with gripping force maintenance	0,1	0,35	0,99
Recommended workpiece weight [kg]	0,6	2,25	5,7
Max. permissible finger length [mm]	30	60	80
Max. permitted weight per finger [kg]	0,03	0,08	0,25
Ambient temperature [°C]			
Min.	-10	-10	-10
Max.	90	90	90
Min. Federkraft [N]			
without gripping force maintenance	-	-	-
with gripping force maintenance AS	30	150	330
with gripping force maintenance IS	30	150	330
Closing force [N]			
without gripping force maintenance	120	450	1140
with gripping force maintenance AS	150	600	1470
with gripping force maintenance IS	-	-	-
Opening force [N]			
without gripping force maintenance	144	540	1320
with gripping force maintenance AS	-	-	-
with gripping force maintenance IS	174	590	1650
IP rating	40	40	40

Size	16	32	50
Operating data for compressed air connection			
Pressure medium	Compressed air, compressed air quality according to ISO 8573-1:7 4 4		
Noise emission [dB(A)]	≤ 72		
Min. pressure [bar]			
without gripping force maintenance	2	2	2
with gripping force maintenance	4	4	4
Max. pressure [bar]			
without gripping force maintenance	8	8	8
with gripping force maintenance	6,5	6,5	6,5
Nominal working pressure [bar]			
without gripping force maintenance	6	6	6
with gripping force maintenance AS	6	6	6
with gripping force maintenance IS	6	6	6

More technical data are included in the catalog data sheet.
Whichever is the latest version.

4 Assembly

4.1 Mechanical connection



⚠ WARNING

Warning: Risk of injury when the machine/system moves unexpectedly!

Remove the energy supplies before starting with assembly and adjustments.

Make sure that no residual energy remains in the system.

Check the evenness of the bolting surface

The values relate to the entire bolting surface.

Requirements for levelness of the bolting surface (Dimensions in mm)

Diameter	Permissible unevenness
< 100	< 0.02
> 100	< 0.05

Mounting

The module can be mounted from the front or the rear.

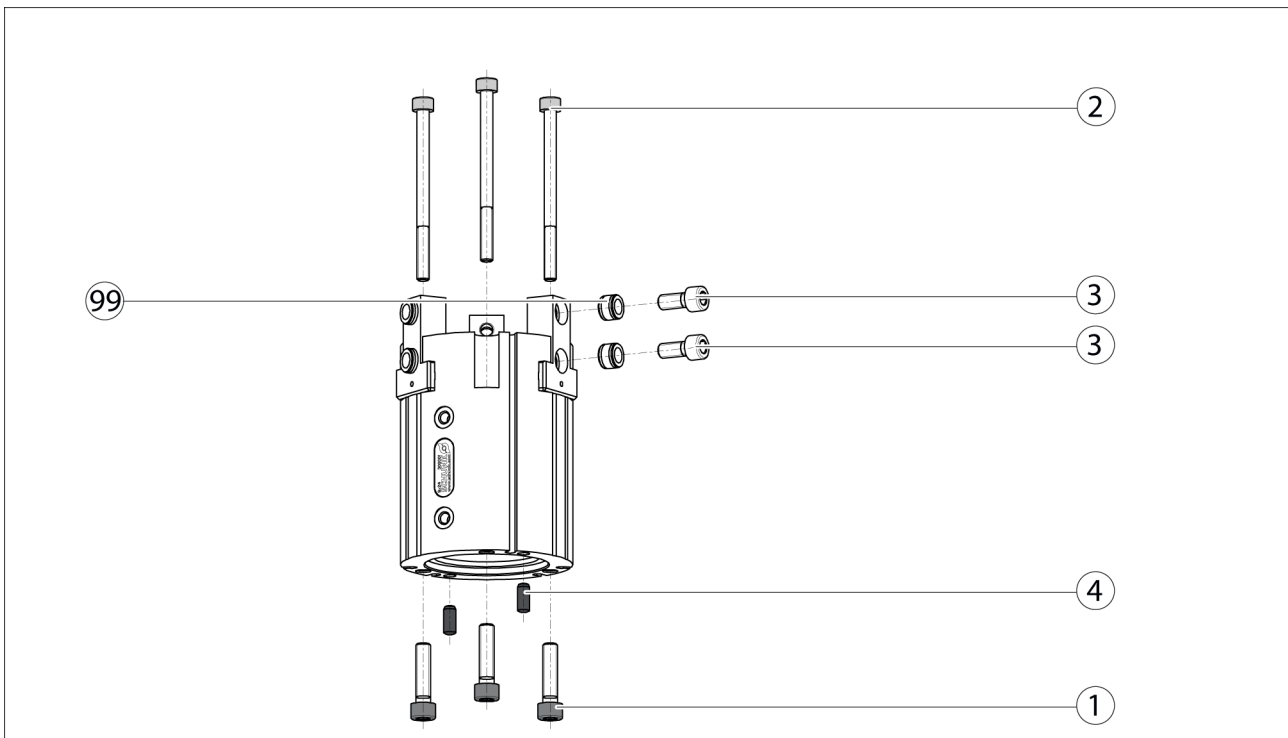

Assembly options

Mounting material (provided by customer)

Item	Mounting	16	32	50
1	Rear module	M3 x max. 7,4	M4 x max. 10	M8 x max. 16
2	Module on the side	M3 x max. 7,4	M4 x max. 10	M8 x max. 16
3	Top jaws	M3 x max. 5	M4 x max. 10	M8 x max. 16
4	Centering pin	Ø3 x max. 3	Ø5 x max. 5	Ø8 x max. 8
99	Centering sleeve	Ø5h6 / 4,35	Ø5h6 / 4,35	Ø8h6 / 5,35

NOTE

- For mounting from the rear fix the module using the provided centering pins (4).
- Mount the module using the mounting bores.
- Mount the top jaws using the mounting bores provided. Use centering sleeves (99).

4.2 Pneumatic connection



⚠ WARNING

Risk of injury when machine/system moves unexpectedly!

- Switch off power supply before assembly and installation.
- Make sure that no residual energy remains in the system.

NOTICE

Damage to the gripper is possible!

If the maximum permissible finger weight or the permissible mass moment of inertia of the fingers is exceeded, the gripper can be damaged.

- A jaw movement always has to be without jerks and bounce.
- You must therefore implement sufficient reduction and/or damping.
- Observe the diagrams and information in the catalog data sheet.

NOTICE

Observe the requirements for the air supply
[Technical data](#) [▶ 16].

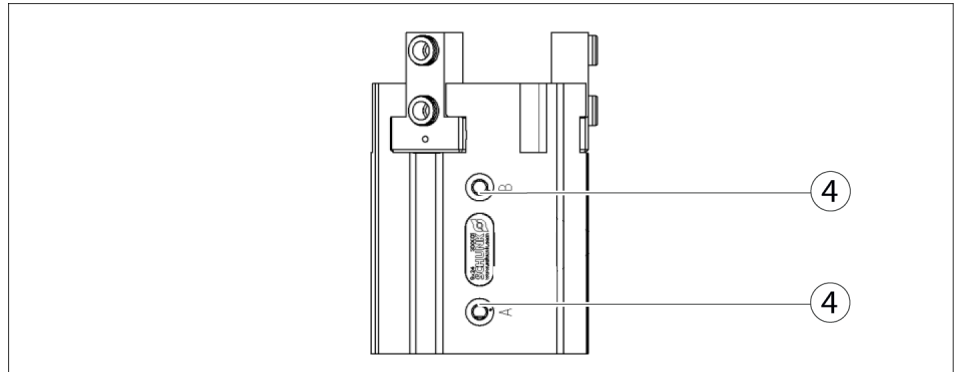

Air connections

Thread diameter of the air connections

Item	Connection	16 - 50
4	Thread diameter of the air connections (A = open, B = close)	2 x M5

- Only open the air connections required.
- Seal air connections not required using the locking screws from the enclosed pack.
- For hose-free direct connections use the two O-rings from the enclosed pack.

Further information on the hose-free direct connection contains the catalog data sheet.

4.3 Sensors

The module is prepared for a number of sensors. Other sensors can be used with a mounting kit.

- If you require further information on sensor operation, contact your SCHUNK contact person or download information from our homepage.
- Technical data for the sensors can be found in the data sheets (included in the scope of delivery).

4.3.1 Programmable magnetic switch (MMS-P)

NOTE

The MMS-P can be used for sizes LGZ 16 to LGZ 50.

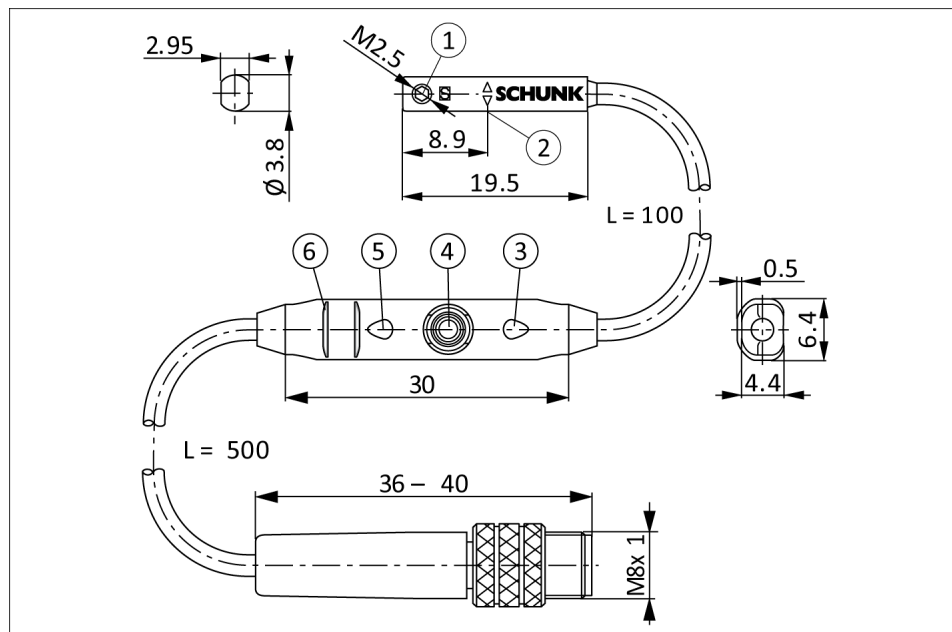

Magnetic switch MMS-P 22

1	Mounting screw	4	Teach-button
2	Center sensor elements	5	LED display
3	LED display	6	Ribs for cable tires

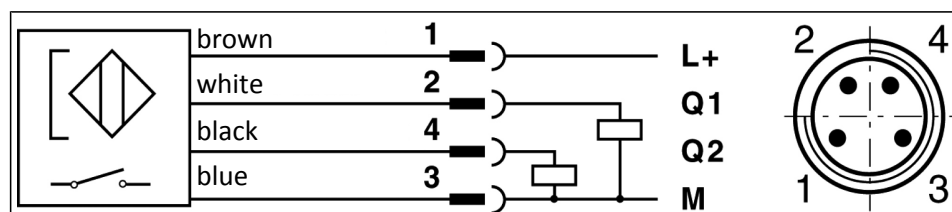

Connection diagram PNP-4 conductor (MMS-P 22)

Types available for order (see catalog):

- MMS-P 22-S-M8-PNP
- MMSK-P 22-S-PNP
- V2-M8-4-2XM8-3

The MMSK-P 22-S-PNP features a cable with open strands so that it can be connected via terminal contacts.

The V2-M8-4-2XM8-3 distributor is used to convert the 4-pin connector plug of the MMS-P 22-S-M8-PNP sensor to two standard M8 plugs with 3 pins each.

Mounting of the sensor

NOTICE

Sensor can be damaged during assembly.

- Do not exceed the maximum tightening torque of 10 Ncm for the set screws!

NOTE

Ferromagnetic material changes the switching positions of the sensor (e.g. Adapter plate made of ordinary steel).

For ferromagnetic adapter plates:

- The module must be first mounted on the adapter plate.
- Then, the position of the magnetic switches has to be set.

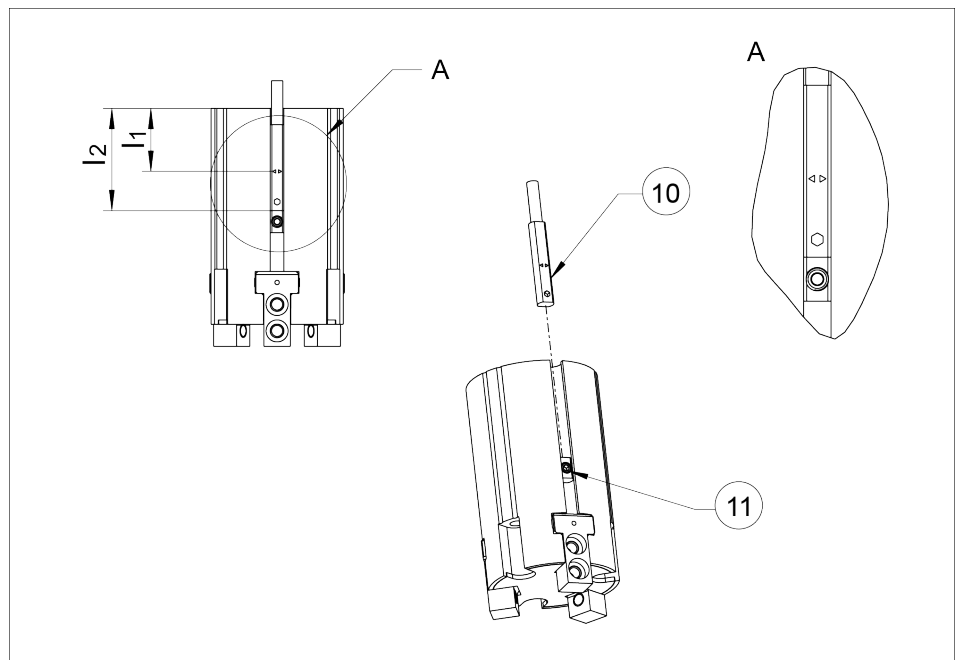

- Push the magnetic switch (10) into the groove until it rests on the back stop (11) (if present).
- If no clamping stop is available, push in the magnetic switch in accordance with dimension l_2 (lower edge gripper up to front side sensor) or with dimension l_1 (lower edge gripper up to the double arrow on the sensor) and then clamp.

Type	Dimension I ₁	Dimension I ₂	Type	Dimension I ₁	Dimension I ₂
LGZ 16 °	14.3 mm	23.2 mm	LGZ 50 °	33.1 mm	42.0 mm
LGZ 16-AS °	12.8 mm	21.7 mm	LGZ 50-AS °	26.1 mm	35.0 mm
LGZ 16-IS °	14.3 mm	23.2 mm	LGZ 50-IS °	33.1 mm	42.0 mm
LGZ 32 °	23.0 mm	31.9 mm			
LGZ 32-AS °	18.0 mm	26.9 mm			
LGZ 32-IS °	23.0 mm	31.9 mm			

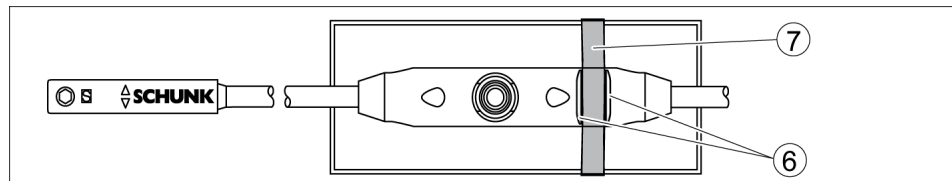

- To relieve the cable, the electronics have to be fixed in place using cable ties (7).
There are ribs (6) in place on the electronics for mounting purposes.

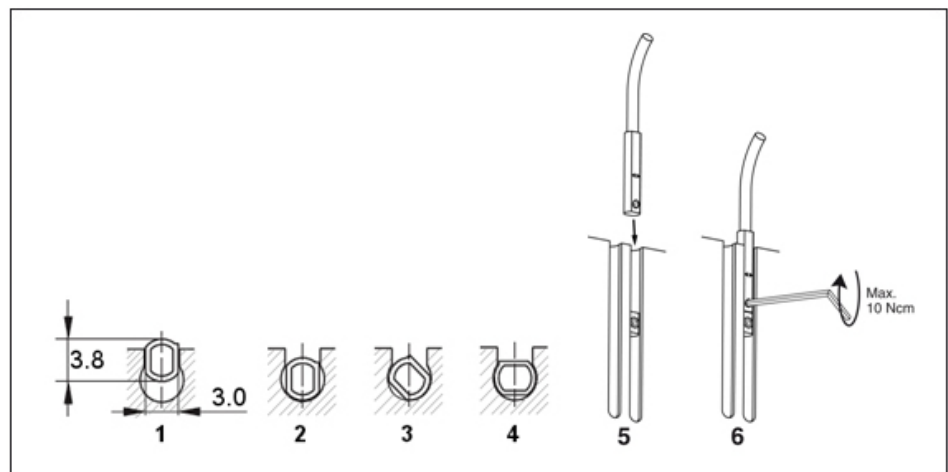

- Turn in the sensor (1 - 4).
OR
Push the sensor axially into the slot until it contacts the stop (5).
- Fix the sensor with an Allen wrench (6).

Adjustment of the switching points

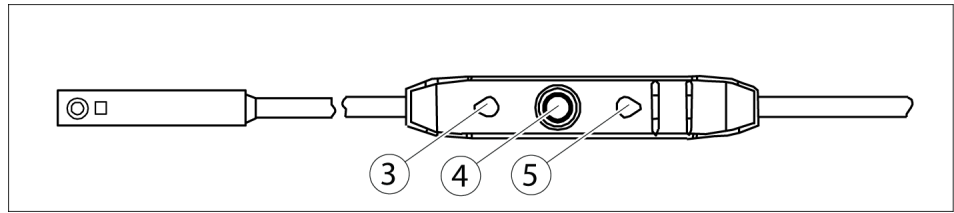

- Press the "Teach" button (4) for 2 seconds.
After 2 seconds, LED 1 (3) flashes.
- Move the gripper to position 1 (e.g. "Open").
- Briefly press the "Teach" button (4).
LED 1 (3) lights up and LED 2 (5) flashes.
- Put the gripper in position 2.
LED 1 (3) should go out as soon as switching point 1 is left.
- Briefly press the "Teach" button (4).
LED 2 (5) lights up.

The switching points are set.

Adjusting the hysteresis

The hysteresis to both switching points will be adjusted automatically corresponding to the characteristics of the magnetic field. The user can set the switching and triggering points of each position a little bit closer than for the automatic mode. The triggering point is closer to the switching point. At the same time the susceptibility to trouble and damage increases. In the mode of the lowest hysteresis, an error signal (such as jitter or untimely switch off) can be avoided, if the sensor is protected against all types of disturbances (i.e. by shielding). Frequent types of disturbances are change in temperature and electro-magnetic influences.

Within the closest fine-teach mode, SCHUNK cannot guarantee EMC-compatibility any more.

The hysteresis adjustment is used for the manual adjustment of the switching points (if necessary).

In case that the hysteresis automatically determined by the sensor should be too high or too low after "the adjustment of the switching points", you may correct the value as follows.

The sensor avoids a too small hysteresis during hysteresis adjustment.

Sensors MMS 22, MMS-P 22, MMS 22-PI1 and MMS 22-PI2

The smallest detectable difference in stroke is defined in the following table:

The smallest detectable difference in stroke based on the nominal stroke

For grippers with X mm nominal stroke per jaw	Min. query range per jaw/ min. queried stroke difference per jaw
$X \leq 5 \text{ mm}$	30% of the nominal stroke per jaw
$X > 5 \text{ mm to } X \leq 10 \text{ mm}$	20% of the nominal stroke per jaw
$X > 10 \text{ mm}$	10% of the nominal stroke per jaw

Example: Product with 7 mm nominal stroke per jaw

$7 \text{ mm} * 20\% = 1.4 \text{ mm}$

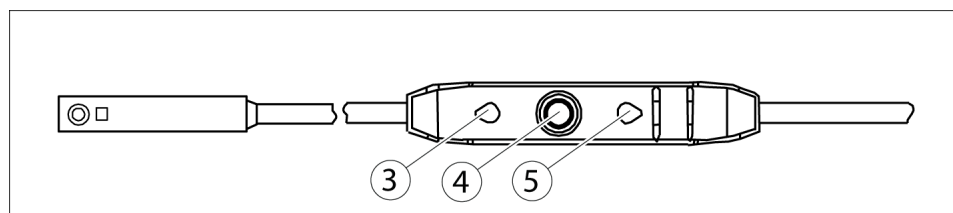

- Press the "Teach" button (4) for 5 seconds.
LED 1 (3) flashes from the second to the fifth second.
LED 1 goes out after 5 seconds.
- Release the "Teach" button.
- Move the gripper to the "switch off point for switching point 1" position.
- Briefly press the "Teach" button (4).
LED 1 (3) flashes 2x.
- Move the gripper to the "switch off point for switching point 2" position.
- Briefly press the "Teach" button (4).
LED 2 (5) flashes 2x.

The assembly of the MMS-P sensor is completed.

5 Troubleshooting

5.1 Product is not moving

Possible cause	Corrective action
Base jaws jam in housing, e.g. mounting surface is not sufficiently even.	Check the evenness of the mounting surface. Mechanical connection [▶ 18]
	Loosen the mounting screws of the product and actuate the product again.
Pressure drops below minimum.	Check air supply. Pneumatic connection [▶ 19]
Compressed air lines switched.	Check compressed air lines. Pneumatic connection [▶ 19]
Proximity switch defective or set incorrect.	Readjust or change sensor.
Unused air connections open.	Close unused air connections.
Flow control valve closed.	Open the flow control valve.
Component part defective.	Replace component or send it to SCHUNK for repair.

5.2 The module does not travel through the entire stroke?

Possible cause	Corrective action
	Pneumatic connection [▶ 19]
	Mechanical connection [▶ 18]

5.3 Module opens or closes abruptly?

Possible cause	Corrective action
Compressed air lines are blocked	Check the compressed air lines for crushing or damage.
Mounting surface is not even enough	Check the levelness of the bolting surface.
Flow control valve is missing or not set correctly	Install and adjust flow control valve.
Load too high	Review permissible weight and length of the jaws. Mechanical connection [▶ 18]

5.4 Gripping force is dropping

Possible cause	Corrective action
Compressed air can escape.	Check seals, if necessary, disassemble the product and replace seals.
Too much grease in the mechanical movement space.	Clean and lubricate product. Maintenance [▶ 28]
Pressure drops below minimum.	Check air supply. Link Pneumatischer Anschluss
Component part defective.	Replace component or send it to SCHUNK for repair.

5.5 Magnetic switch does not work

Possible cause	Corrective action
Use steel screws to mount the gripper	Use stainless steel screws.
Mounting plates, brackets, etc. from non magnetic materials	If possible, use aluminium or plastic.

5.6 Product does not achieve the opening and closing times

Possible cause	Corrective action
Compressed air lines are not installed optimally.	If present: Open the flow control couplings on the product to the maximum that the movement of the jaws occurs without bouncing and hitting.
	Check compressed air lines.
	Inner diameters of compressed air lines are of sufficient size in relation to compressed air consumption.
	Keep compressed air lines between the product and directional control valve as short as possible.
	Flow rate of valve is sufficiently large relative to the compressed air consumption.
	NOTICE! The throttle check valve must not be removed, even if the product has not reached the opening and closing times.
Loading too large.	If, despite optimum air connections, the opening and closing times specified in the catalogue are not achieved, SCHUNK recommends the use of quick-air-vent-valves directly at the product.
	Check permissible weight and length of the gripper fingers.

6 Maintenance

6.1 Maintenance and care

The 3-finger Centric gripper LGZ is not intended for maintenance. Disassembly for maintenance or repair purposes is not possible. A damaged gripper has to be replaced completely.

8 Annex to Declaration of Incorporation

according 2006/42/EG, Annex II, No. 1 B

1. Description of the essential health and safety requirements pursuant to 2006/42/EC, Annex I that are applicable and that have been fulfilled with:

Product designation	3-finger centric gripper
Type designation	LGZ
ID number	0312930 ... 0312938

To be provided by the System Integrator for the overall machine	↓
Fulfilled for the scope of the partly completed machine	↓
Not relevant	↓

1.1	Essential Requirements			
1.1.1	Definitions		X	
1.1.2	Principles of safety integration		X	
1.1.3	Materials and products		X	
1.1.4	Lighting		X	
1.1.5	Design of machinery to facilitate its handling		X	
1.1.6	Ergonomics		X	
1.1.7	Operating positions			X
1.1.8	Seating			X

1.2	Control Systems			
1.2.1	Safety and reliability of control systems		X	
1.2.2	Control devices		X	
1.2.3	Starting		X	
1.2.4	Stopping		X	
1.2.4.1	Normal stop		X	
1.2.4.2	Operational stop		X	
1.2.4.3	Emergency stop		X	
1.2.4.4	Assembly of machinery		X	
1.2.5	Selection of control or operating modes		X	
1.2.6	Failure of the power supply			X

1.3	Protection against mechanical hazards			
1.3.1	Risk of loss of stability			X
1.3.2	Risk of break-up during operation			X
1.3.3	Risks due to falling or ejected objects			X
1.3.4	Risks due to surfaces, edges or angles		X	
1.3.5	Risks related to combined machinery			X
1.3.6	Risks related to variations in operating conditions			X
1.3.7	Risks related to moving parts		X	
1.3.8	Choice of protection against risks arising from moving parts			X
1.3.8.1	Moving transmission parts		X	
1.3.8.2	Moving parts involved in the process			X
1.3.9	Risks of uncontrolled movements			X
1.4	Required characteristics of guards and protective devices			
1.4.1	General requirements			X
1.4.2	Special requirements for guards			X
1.4.2.1	Fixed guards			X
1.4.2.2	Interlocking movable guards			X
1.4.2.3	Adjustable guards restricting access			X
1.4.3	Special requirements for protective devices			X
1.5	Risks due to other hazards			
1.5.1	Electricity supply		X	
1.5.2	Static electricity		X	
1.5.3	Energy supply other than electricity		X	
1.5.4	Errors of fitting		X	
1.5.5	Extreme temperatures			X
1.5.6	Fire			X
1.5.7	Explosion			X
1.5.8	Noise			X
1.5.9	Vibrations			X
1.5.10	Radiation	X		
1.5.11	External radiation	X		
1.5.12	Laser radiation	X		
1.5.13	Emissions of hazardous materials and substances			X
1.5.14	Risk of being trapped in a machine	X		
1.5.15	Risk of slipping, tripping or falling	X		
1.5.16	Lightning			X

1.6	Maintenance			
1.6.1	Machinery maintenance		X	
1.6.2	Access to operating positions and servicing points		X	
1.6.3	Isolation of energy sources		X	
1.6.4	Operator intervention		X	
1.6.5	Cleaning of internal parts		X	
1.7	Information			
1.7.1	Information and warnings on the machinery		X	
1.7.1.1	Information and information devices		X	
1.7.1.2	Warning devices		X	
1.7.2	Warning of residual risks		X	
1.7.3	Marking of machinery	X		
1.7.4	Instructions	X		
1.7.4.1	General principles for the drafting of instructions	X		
1.7.4.2	Contents of the instructions	X		
1.7.4.3	Sales literature	X		
	The classification from Annex 1 is to be supplemented from here forward.			
2	Supplementary essential health and safety requirements for certain categories of machinery			X
2.1	Foodstuffs machinery and machinery for cosmetics or pharmaceutical products			X
2.2	Portable hand-held and/or guided machinery			X
2.2.1	Portable fixing and other impact machinery			X
2.3	Machinery for working wood and material with similar physical characteristics			X
3	Supplementary essential health and safety requirements to offset hazards due to the mobility of machinery		X	
4	Supplementary essential health and safety requirements to offset hazards due to lifting operations		X	
5	Supplementary essential health and safety requirements for machinery intended for underground work			X
6	Supplementary essential health and safety requirements for machinery presenting particular hazards due to the lifting of persons		X	