

READ THIS FIRST

Model W1680

*****IMPORTANT UPDATE*****

Applies to Owner's Manual

Printed July, 2000

Phone #: (360) 734-3482 • Tech Support: tech-support@shopfox.biz • Web: www.shopfox.biz



For Machine Serial #'s 13943 & Higher

The following changes were recently made to this machine since the owner's manual was printed:

- Changed the depth stop bracket.
- Added a chuck guard.

Aside from the information contained in this update, all other content in the owner's manual applies and **MUST** be read and understood for your own safety. **Important: Keep this update with the owner's manual for future reference.**

If you have any further questions about this manual update or the changes made to the machine, contact our Technical Support.

Changed & Added Parts

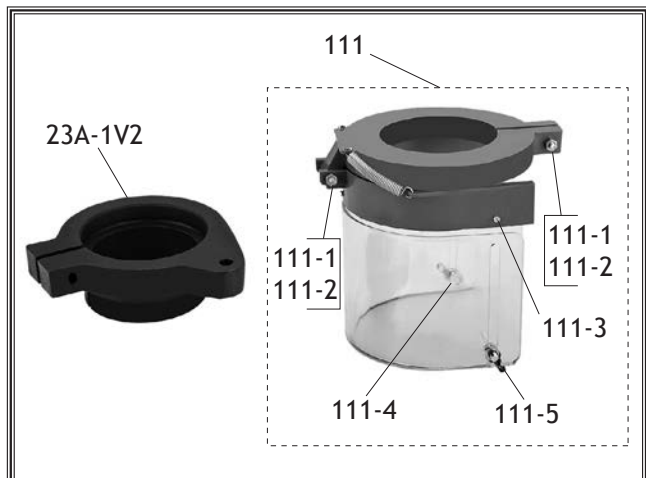

REF	PART #	DESCRIPTION
23A-1V2	X1680023A-1V2	DEPTH STOP BRACKET V2.12.12
111	X1680111	CHUCK GUARD ASSEMBLY
111-1	XP551M	PHLP HD SCR M4-.7 X 30
111-2	XPN04M	HEX NUT M4-.7
111-3	XPHTEK47M	TAP SCREW M2.2 X 4.5
111-4	XPB107M	HEX BOLT M5-.8 X 12
111-5	XPWN05M	WING NUT M5-.8

Installation

Place the chuck guard over the bottom flange of the pre-installed depth stop bracket (see example photo in **Figure 1**), and tighten the Phillips head screw and hex nut to secure it.

Note: To prevent the guard from slipping off during installation, move the table up to support it. Or, have an assistant hold the guard in place while you secure it.

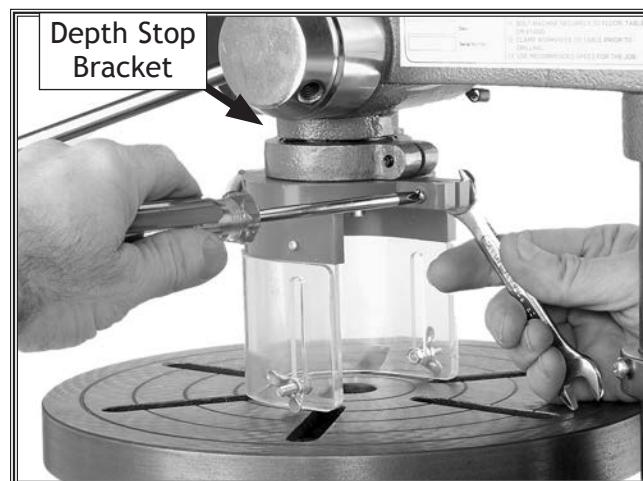

Figure 1. Example photo of installing chuck guard assembly.

COPYRIGHT © FEBRUARY, 2013 BY WOODSTOCK INTERNATIONAL, INC.

WARNING: NO PORTION OF THIS MANUAL MAY BE REPRODUCED IN ANY SHAPE OR FORM WITHOUT

#15656TS

THE WRITTEN APPROVAL OF WOODSTOCK INTERNATIONAL, INC.

Printed in China



MODEL W1680 17" DRILL PRESS



INSTRUCTION MANUAL

Phone: 1-800-840-8420 • On-Line Technical Support: tech-support@woodstockint.com

COPYRIGHT © 2000 BY WOODSTOCK INTERNATIONAL, INC.

WARNING: NO PORTION OF THIS MANUAL MAY BE REPRODUCED IN ANY SHAPE OR FORM WITHOUT
THE WRITTEN APPROVAL OF WOODSTOCK INTERNATIONAL, INC.

Printed in China

Table Of Contents

	PAGE
1. INTRODUCTION	2
ABOUT YOUR NEW DRILL PRESS	2
WOODSTOCK SERVICE AND SUPPORT	2
WARRANTY AND RETURNS	3
MACHINE SPECIFICATIONS	3
2. SAFETY FIRST!	4
STANDARD SAFETY INSTRUCTIONS	4-5
DRILL PRESS SAFETY	5
ELECTRICAL REQUIREMENTS	6
AVOIDING POTENTIAL INJURIES	7
3. ASSEMBLY INSTRUCTIONS	8
BOX CONTENTS	8
BASE AND COLUMN	9
TABLE SUPPORT	10-11
HEADSTOCK	12-13
HANDLES	13
DRILL CHUCK AND ARBOR	14-15
ARBOR REMOVAL	15
4. ADJUSTMENTS	16
SPEED CHANGE	16-17
SPINDLE ADJUSTMENTS	17
TABLE ADJUSTMENTS	18
5. OPERATIONS	19
TEST RUN	19
DRILL CHANGES	20
6. MAINTENANCE	21
GENERAL	21
TABLE AND BASE	21
LUBRICATION	21
7. CLOSURE	22
WIRE DIAGRAM	23
PARTS BREAKDOWN AND PARTS LISTS	24-25

USE THE QUICK GUIDE PAGE LABELS TO SEARCH OUT INFORMATION FAST!





INTRODUCTION

ABOUT YOUR NEW DRILL PRESS

This new Shop Fox® Drill Press has been specially designed by Woodstock International, Inc. to provide many years of trouble free service. Close attention to detail, ruggedly built parts and a rigid quality control program assure safe and reliable operation.

The Model W1680 Drill Press is capable of a wide variety of drilling operations in metal, wood and plastic. The tilting table allows drilling angles from 90° to 0°. Precision ground spindle, table, base and column ensure dependable accuracy. The W1680 is packaged with a drill chuck, motor, work light and paddle switch with removable safety key.

Woodstock International, Inc. is committed to customer satisfaction in providing this manual. It is our intent to make sure all the information necessary for safety, ease of assembly, practical use and durability of this product be included.

If you should have any comments regarding this manual, please feel free to contact us at:

Woodstock International, Inc.
P.O. Box 2309
Bellingham, WA 98227

WOODSTOCK SERVICE AND SUPPORT

We stand behind our machines! In the event that a defect is found, parts are missing or questions arise about your machine, please contact Woodstock International Service and Support at 1-360-734-3482 or at tech-support@woodstockint.com. Our knowledgeable staff will help you troubleshoot problems, send out parts or arrange warranty returns.

WARRANTY AND RETURNS

Woodstock International, Inc. warrants all SHOP FOX® machinery to be free of defects from workmanship and materials for a period of 2 years from the date of original purchase by the original owner. This warranty does not apply to defects due directly or indirectly to misuse, abuse, negligence or accidents, lack of maintenance, or to repair or alterations made or specifically authorized by anyone other than Woodstock International, Inc.

Woodstock International, Inc. will repair or replace, at its expense and at its option, the SHOP FOX® machine or machine part which in normal use has proven to be defective, provided that the original owner returns the product prepaid to the SHOP FOX® factory service center or authorized repair facility designated by our Bellingham, WA office, with proof of their purchase of the product within 2 years, and provides Woodstock International, Inc. reasonable opportunity to verify the alleged defect through inspection. If it is determined there is no defect, or that the defect resulted from causes not within the scope of Woodstock International Inc.'s warranty, then the original owner must bear the cost of storing and returning the product.

This is Woodstock International, Inc.'s sole written warranty and any and all warranties that may be implied by law, including any merchantability or fitness, for any particular purpose, are hereby limited to the duration of this written warranty. We do not warrant that SHOP FOX® machinery complies with the provisions of any law or acts. In no event shall Woodstock International, Inc.'s liability under this warranty exceed the purchase price paid for the product, and any legal actions brought against Woodstock International, Inc. shall be tried in the State of Washington, County of Whatcom. We shall in no event be liable for death, injuries to persons or property or for incidental, contingent, special or consequential damages arising from the use of our products.

Every effort has been made to ensure that all SHOP FOX® machinery meets high quality and durability standards. We reserve the right to change specifications at any time because of our commitment to continuously improve the quality of our products.

Machine Specifications

Capacities:

Spindle Travel	3 ¹ / ₄ "
Max. Distance, Spindle to Base	49"
Max. Distance, Spindle to Table	31 ¹ / ₂ "
Spindle Taper	MT #3
Swing	17"
Chuck Size	⁵ / ₈ " (16mm), keyed
Speeds	12
Range of Speeds	150, 260, 320, 380, 480, 540, 980, 1160, 1510, 1650, 2180, 3050 RPM
Drilling Capacity	³ / ₄ " Diameter in Steel

Motor:

Type	TEFC Capacitor Start Induction
Horsepower	1 HP
Phase / Cycle	Single Phase / 60 Hz
Amps	10
Voltage	110V Only
RPM	1720
Power Transfer	V-Belt Drive
Bearings	Shielded & Lubricated Ball Bearings
Switch	Toggle ON/OFF Switch, w/ Safety Lock Tab

SAFETY FIRST!

READ MANUAL BEFORE OPERATING MACHINE FAILURE TO FOLLOW INSTRUCTIONS BELOW WILL RESULT IN PERSONAL INJURY

SAFETY



Indicates an imminently hazardous situation which, if not avoided, WILL result in death or serious injury.



Indicates a potentially hazardous situation which, if not avoided, COULD result in death or serious injury.



Indicates a potentially hazardous situation which, if not avoided, MAY result in minor or moderate injury. It may also be used to alert against unsafe practices.

NOTICE

This symbol is used to alert the user to useful information about proper operation of the equipment.

1. **Thoroughly read the instruction manual before operating your machine.** Learn the applications, limitations and potential hazards of this machine. Keep manual in a safe, convenient place for future reference.
2. **Keep work area clean and well lighted.** Clutter and inadequate lighting invite potential hazards.
3. **Ground all tools.** If a machine is equipped with a three-prong plug, it must be plugged into a three-hole electrical outlet or grounded extension cord. If using an adapter to aid in accommodating a two-hole receptacle, ground using a screw to a known ground.
4. **Wear eye protection at all times.** Use safety glasses with side shields or safety goggles, meeting the national safety standards, while operating this machine.
5. **Avoid dangerous environments.** Do not operate this machine in wet or open flame environments. Airborne dust particles could cause an explosion and severe fire hazard.
6. **Ensure all guards are securely in place and in working condition.**
7. **Make sure switch is in the "OFF" position** before connecting power to machine.
8. **Keep work area clean;** free of clutter, grease, etc.
9. **Keep children and visitors away.** All visitors should be kept a safe distance away while operating unit.
10. **Childproof workshop** with padlocks, master switches or by removing starter keys.

11. **Disconnect machine when cleaning, adjusting or servicing.**
12. **Do not force tool.** The machine will do a safer and better job at the rate for which it was designed.
13. **Use correct tool.** Do not force machine or attachment to do a job for which it was not designed.
14. **Wear proper apparel.** Do not wear loose clothing, neck ties, gloves, jewelry, etc.
15. **Remove adjusting keys and wrenches.** Before turning the machine on, make it a habit to check that all adjusting keys and wrenches have been removed.
16. **Use proper extension cord.** When using an extension cord, make sure it is in good condition. When extension cord is 100' and less in length, use those that are rated Hard Service (grade S) or better, and that have a conductor size of 16 A.W.G. A drop in line voltage, loss of power and overheating can result when using an undersized cord. The extension cord should have a ground wire and ground plug pin, as well.
17. **Keep proper footing and balance** at all times.
18. **Do not leave machine unattended.** Wait until it comes to a complete stop before leaving the area.
19. **Perform machine maintenance and care.** Follow lubrication and accessory attachment instructions in the manual.
20. **Keep machine away from open flame.** Operating machines near pilot lights and/or open flames creates a high risk if dust is dispersed in the area. Dust particles and an ignition source may cause

Additional Safety Instructions For Drill Presses

1. **Always operate your drill press at speeds** that are appropriate for the drill bit size and the material that you are drilling.
2. **Feed the drill bit evenly into the workpiece.** Back the bit out of deep holes and clear the chips with a brush after you have turned the machine off.
3. **Make sure the drill bit you are using is tightened properly.** Use only round, hex or triangular shank drill bits.
4. **Never do maintenance or change speeds with this machine plugged in.**
5. **Never use tools that are in poor condition.** Cutting tools that are dull or damaged are difficult to control and may cause serious injury.
6. **Never drill sheet metal unless it is clamped securely to the table.**
7. **Work should be positioned** in such a way as to avoid drilling into the table.
8. **A face shield used with safety glasses is recommended.**
9. **Always clamp workpiece securely to table before drilling.** Never hold a workpiece by hand while drilling.
10. **Habits - good and bad - are hard to break.** Develop good habits in your shop and safety will become second-nature to you.

ELECTRICAL REQUIREMENTS

110V Operation

The Shop Fox® W1680 Drill Press is supplied for 110 volt operation, only. The motor supplied with your new drill press is rated at 1 horse power and will draw approximately 10 amps. When choosing an outlet for this machine, consider using one with a 15 amp circuit breaker or fuse. Keep in mind that a circuit being used by other machines or tools at the same time will add to the electrical load being applied by the drill press. Add up the load ratings of all machines on the circuit. If this number exceeds the rating of the circuit breaker or fuse, use a different outlet.

Extension Cords

When it is necessary to use an extension cord, use the following guidelines:

- Use cords rated for Hard Service
- Never exceed a length of 100 feet
- Use cords with 14 ga. wire or bigger
- Insure cord has a ground wire and pin
- Do not use cords in need of repair

Grounding

This machine must be grounded! See Figure 1. The electrical cord supplied with the W1680 comes with a grounding pin. Do not remove it. If your outlet does not accommodate a ground pin, have it replaced by a qualified electrician or have an appropriate adapter installed. Please note: when using an adapter, the adapter must be grounded.

⚠ WARNING

This equipment must be grounded. Verify that any existing electrical outlet and circuit you intend to plug into is actually grounded. If it is not, it will be necessary to run a separate 12 A.W.G. copper grounding wire from the outlet to a known ground. Under no circumstances should the grounding pin from any three-pronged plug be removed. Serious injury may occur.

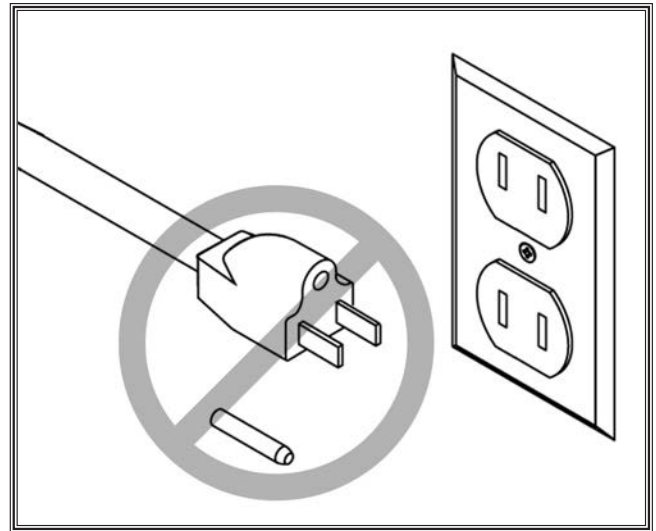

Never remove grounding pin.

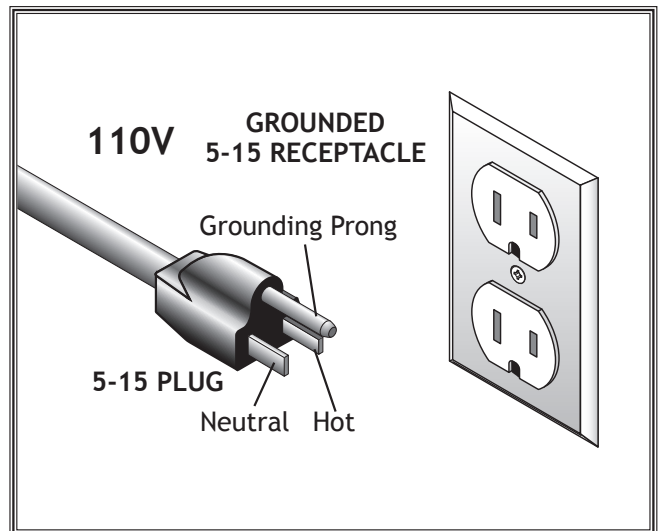

Figure 1. Typical 110V 3-prong plug and outlet.

AVOIDING POTENTIAL INJURIES



Figure 2. Never drill, holding workpiece by hand.



Figure 3. Keep fingers away from spinning tool.



Fig. 4. Remove Switch Safety Key when not in use.



Figure 5. Unplug machine when changing bulbs.

ASSEMBLY INSTRUCTIONS

ASSEMBLY

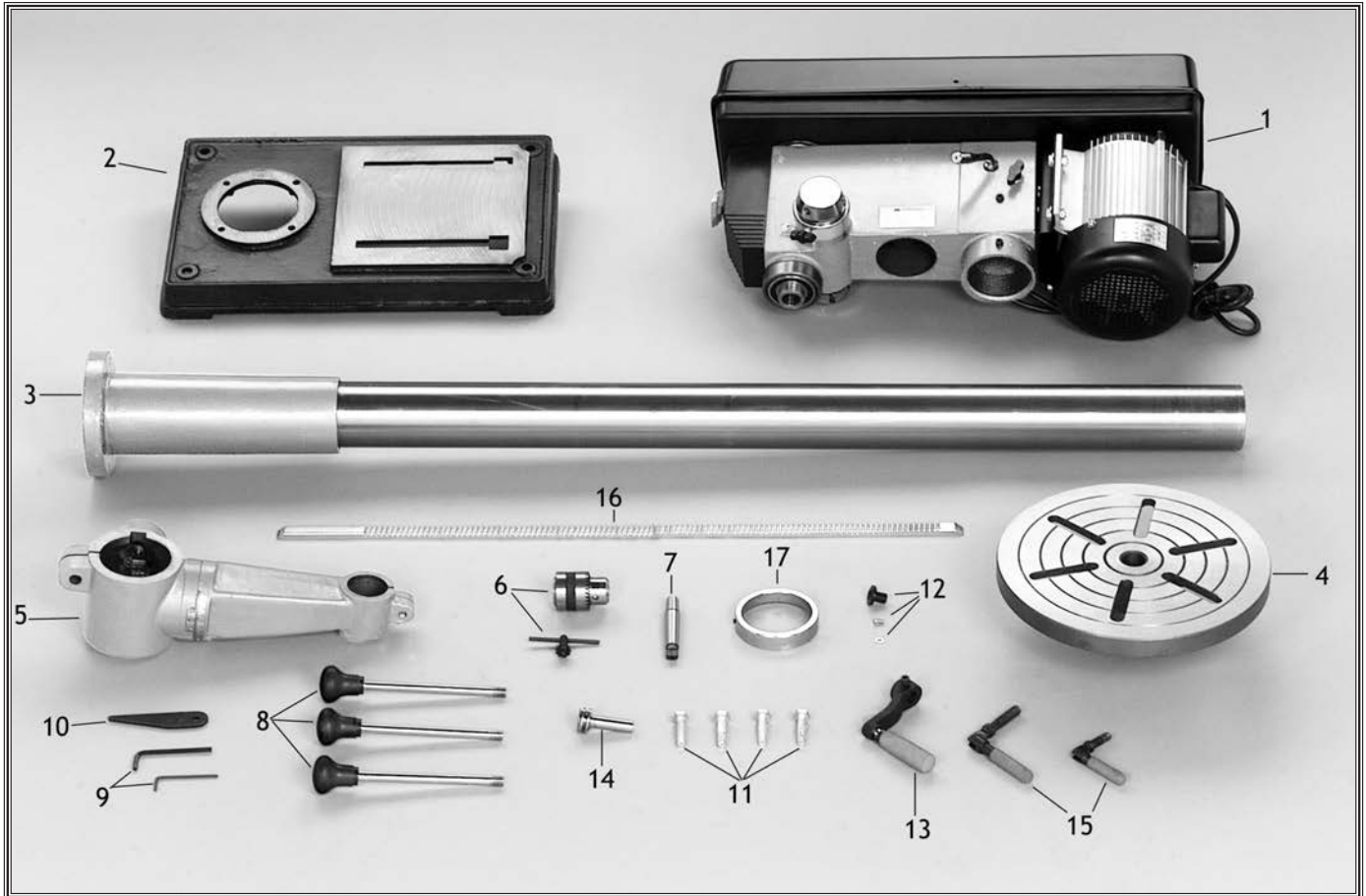

Figure 6. Components laid out for identification.

The following is a description of the components shipped with the Shop Fox® W1680 Drill Press. It is recommended that the components be laid out in a similar fashion to those in **Figure 6**. This will help in identification before beginning assembly. Should any part be missing, examine the packaging carefully and check under the belt guard. If any key parts are missing, call Woodstock International, Inc. at 360-734-3482 or tech-support@woodstockint.com.

- | | |
|------------------------|-------------------------------|
| 1. Headstock Assembly | 10. Wedge |
| 2. Base | 11. Hex Head Bolts (4) |
| 3. Column | 12. Belt Cover Knob and Screw |
| 4. Table | 13. Handle |
| 5. Column Lock | 14. Pinion Gear |
| 6. Drill Chuck and Key | 15. Lock Handles (2) |
| 7. Drill Chuck Arbor | 16. Rack |
| 8. Spindle Handles (3) | 17. Column Ring |
| 9. Allen® Wrenches (2) | |

While the main components of the Shop Fox® W1680 Drill Press are assembled at the factory, some assembly is required. The following is the recommended sequence best suited for final assembly.

TOOLS REQUIRED: You will need a 11/16" open end wrench, a rubber or wooden mallet and a 5mm Allen® wrench (supplied).



⚠ WARNING
Wear safety glasses during the entire assembly process. Failure to comply may result in serious personal injury.

Base/Column

The W1680 Drill Press is a floor model and should be secured to the floor or the base should be extended with plywood to maximize stability. The use of a mobile base is not recommended.



Figure 7. Secure base to floor.

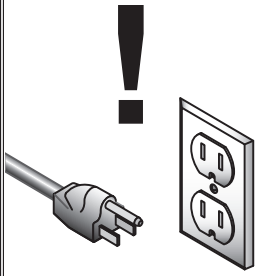

⚠ WARNING
Do not connect the machine to power at this time. The machine must remain unplugged throughout the entire assembly process. Failure to do this may result in serious personal injury.

1. Ensure machine is unplugged!
2. Secure base to floor with the appropriate anchor bolts (not included). See Figure 7.

OR

2. Secure base to a 4' x 4' x 3/4" sheet of plywood. Base should be positioned along the back edge of plywood and centered from side to side as in Figure 8. Use base to lay out hole pattern. Drill holes and secure base to plywood with carriage bolts.
3. Place the column on the base and line up the 4 mounting holes. Secure tightly with the three M10-1.5 x 40mm hex head bolts included using the open end wrench provided.

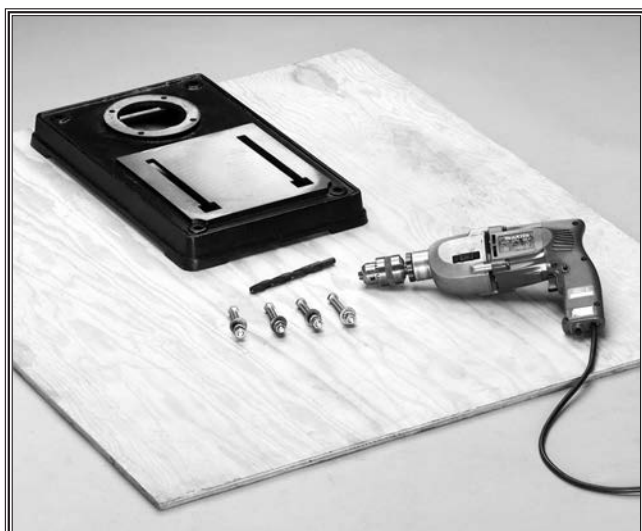

Figure 8. Secure base to plywood.

Table Support

1. Thread the 12mm table lock handle 3 turns into the table support bracket.
2. Insert the pinion into the hole on the side of the table support bracket from the inside, starting with the pinion shaft. **Figure 9.** Align setscrew in crank handle with flat, **Figure 10,** on pinion shaft and secure using the 3mm Allen® wrench provided.
3. Examine the rack and note that the gear teeth extend further on one end than the other. The shorter end must be positioned down. Insert the rack into the table support bracket and align with pocket. The end of the rack where the gear teeth are closest to the end should be positioned down as in **Figure 11.** The gear teeth on the rack must also face out.



Figure 9. Insert the pinion gear from the inside.

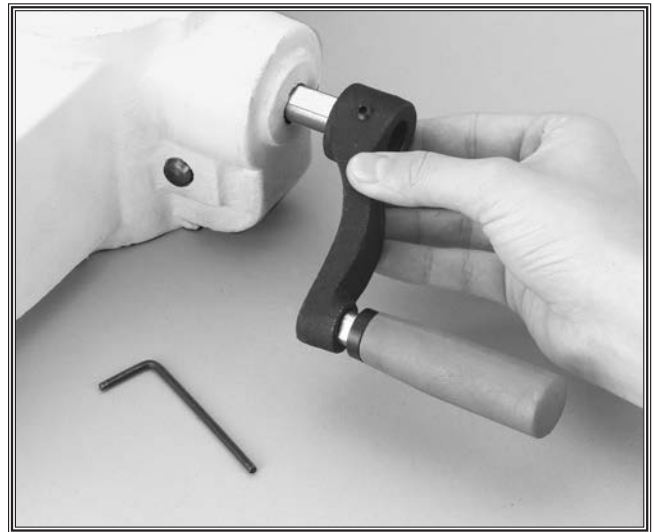

Figure 10. Align setscrew with flat on pinion.



Figure 11. Correct rack orientation.



Figure 12. Bottom of rack in position.



Figure 13. Inside bevel in the correct position.

Table Support, Cont.

4. Slide the table support bracket onto the column while holding the rack in place. Allow the bracket to go down until the bottom of the rack contacts the shoulder on the column support. **Figure 12.** Secure the table with the lock handle.
5. Slide the column ring onto the column with the inside bevel in the down position. **Figure 13.** Adjust the ring until the tip of the rack fits inside the bevel. Tighten the setscrew on the ring.

NOTICE

Use caution when tightening set screw. Over tightening will split column ring.

Head Stock



⚠ CAUTION

The headstock represents a heavy load. Seek assistance before beginning this step.

1. The bottom of the headstock has a pocket for inserting the column. An assistant will be needed to position the pocket over the column, as in **Figure 14**. Allow the headstock to slide down until it stops (approximately 4").
2. Align the headstock directly over the foot of the base by using a plumb bob. Lay a measuring tape or ruler across the drill press base and find its center. Suspend the plumb line from the center of the headstock label and lower the bob until it is near the tape/ruler as in **Figure 15**. Adjust headstock from side to side until the tip is equidistant from the left and right sides.

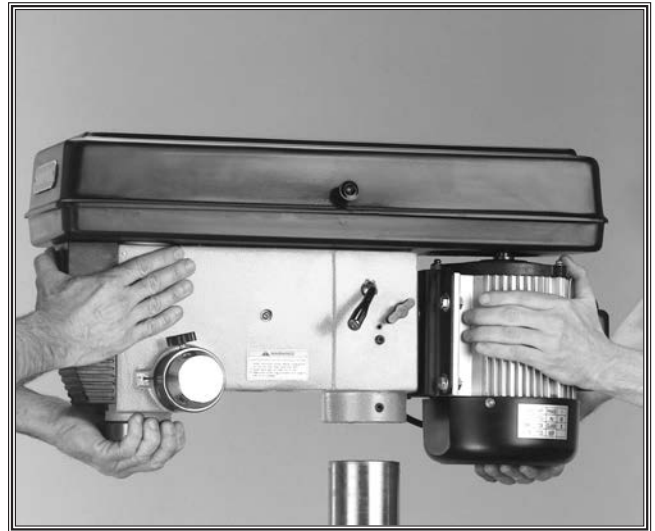

Figure 14. Align pocket in headstock with column.

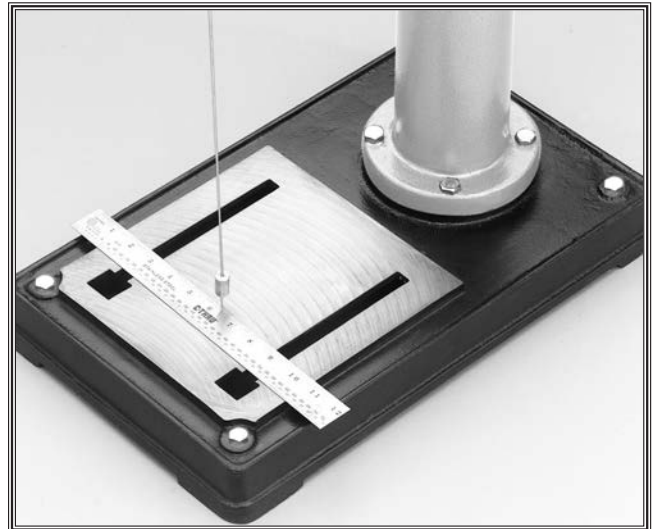

Figure 15. Align headstock with base.



Figure 16. Tighten setscrews to secure headstock.

3. Tighten the two setscrews in Figure 16 to secure the headstock to the column



Figure 17. Installing handles.

Handles

Three handles are supplied with your new Drill Press. Thread them into the hub. Figure 17.

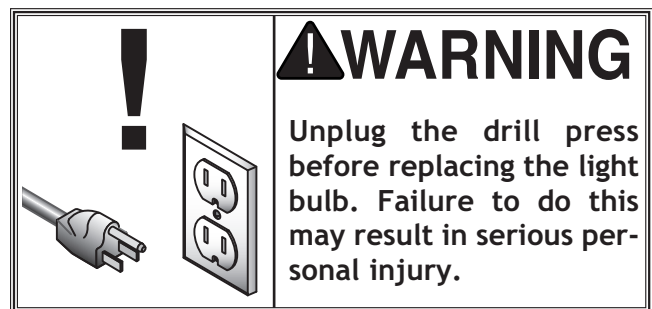

Installing Light Bulb

The Shop Fox® 17" Drill Press is fitted with a light socket that accommodates standard sized bulbs.



Figure 17b. Installing a light bulb.

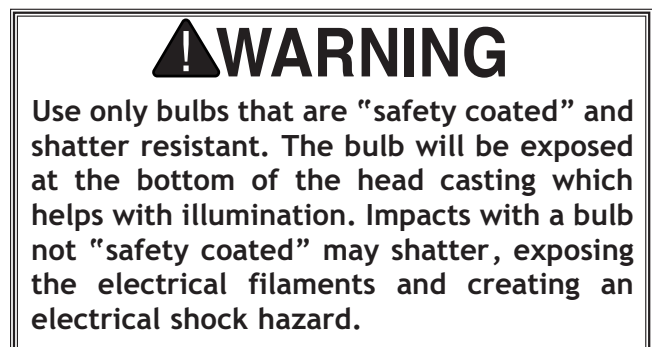

Before installing a light bulb, unplug the drill press. Secure bulb in opening behind the spindle as in Figure 17b.

Drill Chuck and Arbor

The drill chuck is attached to the drill spindle by means of a drill chuck arbor. Matched tapers on the arbor and the back of the chuck create an almost permanent assembly when properly joined. To assemble the drill chuck and mount it to the spindle, carefully follow the instructions below:

⚠ CAUTION

Many of the solvents commonly used to clean machinery can be highly flammable, and toxic when inhaled or ingested. Always work in well-ventilated areas far from potential ignition sources when dealing with solvents. Use care when disposing of waste rags and towels to be sure they do not create fire or environmental hazards. Keep children and animals safely away when cleaning and assembling this machine.

1. The drill chuck, arbor and spindle socket must be thoroughly cleaned before assembly. It is recommended that mineral spirits be used for this task. Refer to the safety warnings on the container of the mineral spirits. Failure to clean the mating surfaces may result in separation and wear.
2. Use the chuck key provided to adjust the jaws of the chuck until they are well inside the drill chuck body.
3. Place the drill chuck on a workbench face down. The arbor has a short taper and a long taper. Place the short taper into the socket in the back of the drill chuck and tap with a rubber or wooden mallet. **See Figure 19.** If the chuck fails to remain secure on the arbor, repeat step 1 and 2. **Do not** use excessive force. The drill chuck and arbor

DO NOT use a steel hammer on the drill chuck to seat it onto the spindle. Damage will occur to the chuck and/or spindle which may make them unusable or unsafe.

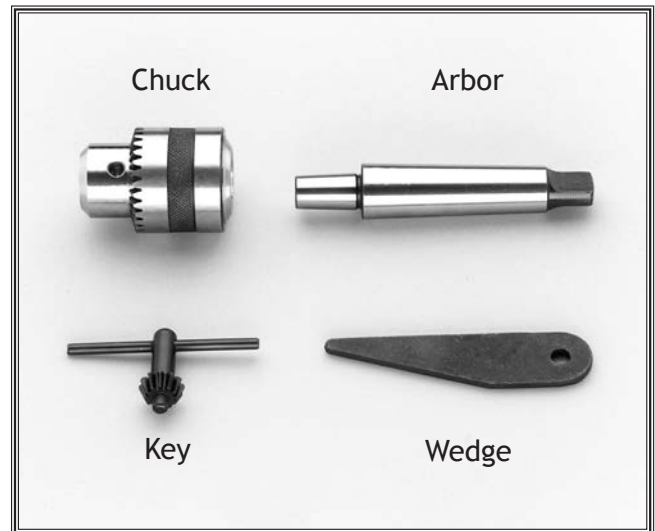

Figure 18. Chuck components identification.



Figure 19. Seating the arbor into chuck.

⚠ WARNING

Do not use gasoline or other petroleum-based solvents to remove this protective coating. These products generally have low flash points which makes them extremely flammable. A risk of explosion and burning exists if these products are used. Serious personal injury may occur.



Figure 20. Seating arbor into spindle.

4. Slide the arbor into the spindle socket while slowly rotating drill chuck. The socket has a rectangular pocket in which the tang (or flat portion of the arbor) fits into. Once the tang is oriented correctly the drill chuck will not rotate without turning the spindle.
5. Tap the end of the drill chuck with a rubber or wooden mallet to seat the drill chuck. See Figure 20.



Figure 21. Inner and outer slots aligned.

Arbor Removal

	! WARNING
	<p>Wear safety glasses when removing drill chuck from spindle. Failure to comply may result in serious personal injury.</p>

A wedge is included with the Shop Fox® Drill Press which aids in drill chuck arbor removal.

1. Rotate the spindle handles until a slot is exposed in the side of the quill.
2. Rotate the spindle until the inner slot is aligned with the outer. See Figure 21. You will see through the spindle when slot is properly aligned.
3. Insert the wedge into the slot and allow quill to rise, trapping the wedge. Hold the drill chuck with one hand and tap on the wedge with a hammer. See Figure 22.



Figure 22. Using wedge to remove arbor.

ADJUSTMENTS

Speed Change

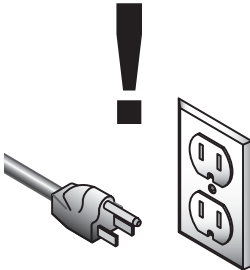

! WARNING

Unplug the drill press before changing speeds to avoid accidental start up. Failure to do this may result in serious personal injury.

Unplug the drill press before changing speeds. The Drill Press has 12 speeds ranging from 140 to 3050 RPM. There is a speed chart located under the belt guard and one on the following page. Refer to these while reading these instructions.

1. Loosen the belt tension lock knobs on both sides of the headstock. See Figure 23.
2. The motor is now free to move. Rotate the belt tension lever to take tension off the V-belts.
3. Locate the desired speed on the chart and move the V-belts to the desired V-grooves on the motor, idler and spindle pulleys. See Figure 24.
4. Rotate the belt tension lever until belts are tight. See Figure 25. Tighten both lock knobs.
5. Close the cover.



! WARNING

Never operate drill press with belt cover in the open position. Your hand may become trapped in a belt and serious personal injury will occur.



Figure 23. Loosening the lock knob.

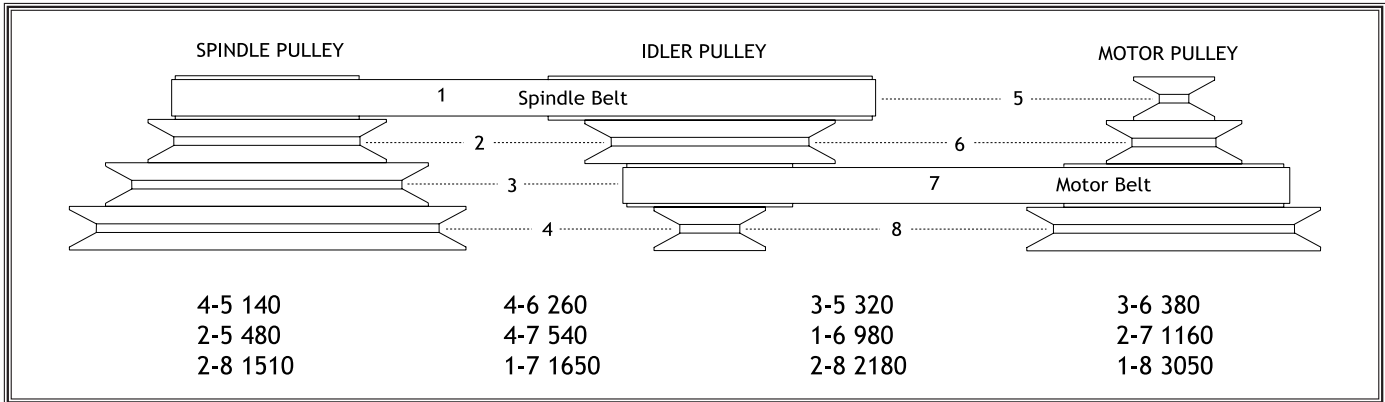

Figure 24. Adjusting belt to desired speed.



Figure 25. Grasp the lever and turn.

More About Speed Changes



The speed chart above is included to help illustrate belt changes necessary to produce a desired speed. Select the proper speed for the job at hand and find it on the speed chart above. Move the belts to the indicated location on the chart. The belt setting in the example above, shows the spindle belt is in the #1 position and the motor belt is in the #7 location. This will produce a speed of 1,650 RPM.



Figure 26. Loosening collar lock knob.



Figure 27. Actual stop depth being measured.

Spindle Adjustments

Your new drill press comes fitted with a depth stop for use when drilling. Follow the instructions below for use.

1. Loosen the depth collar lock knob. **Figure 26.**
2. Rotate the depth collar to the desired depth indicated by the scale on the collar. Secure the collar with the lock knob.
3. Test the depth stop by measuring how far the spindle actually moves when handles are rotated. **Figure 27.** Make adjustment using step 1 and step 2 if needed.

Table Adjustments

The table can be adjusted for height, rotation and angle. Follow these instructions to adjust height:

1. Loosen the support bracket lock knob. Turn the table hand crank to lift or lower the table. **Figure 28.**
2. Always lock the support bracket in place before operating machine.

Adjust rotation:

1. Loosen the lock handle located under the table. **See Figure 29.** Rotate table the desired amount.
2. Always lock the support bracket in place before operating machine.

Adjust angle:

1. Turn the nut indicated by the arrow in **Figure 30**, in a clockwise direction. This will draw the location pin out of the casting. Once loose, pull pin and nut out and set it in a safe place until needed.
2. Loosen large bolt in the center of the support bracket.
3. Rotate the bracket to the desired angle. Use the scale on the side of the bracket or protractor to set angle. Lock in place by tightening bolt.

When repositioning table to 0° position, loosen the large bolt in the center of the support casting. Rotate the support casting until the degree scale reads 0°. Carefully tap the location pin back into the hole from which it came until it stops. Unscrew the nut on the location pin until it is flush with the end of the threads. This will protect the threads when you tap it into place with a hammer. Turn the nut clockwise until it is snug against the casting and then tighten the large bolt in the center. The table is now set to the factory pre-set angle.

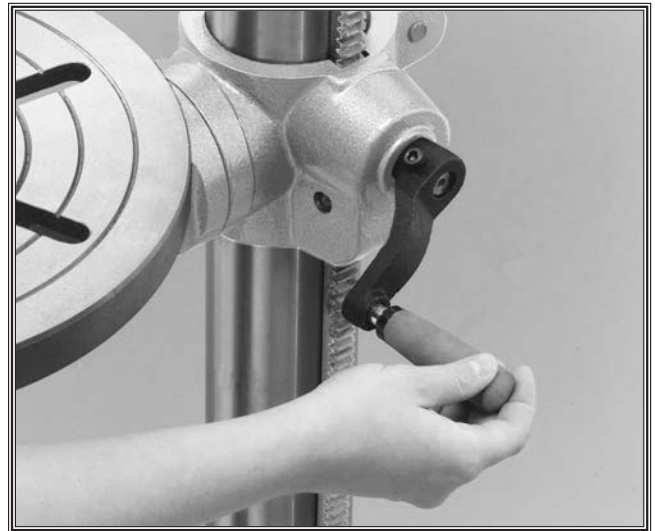

Figure 28. Changing table height with crank.

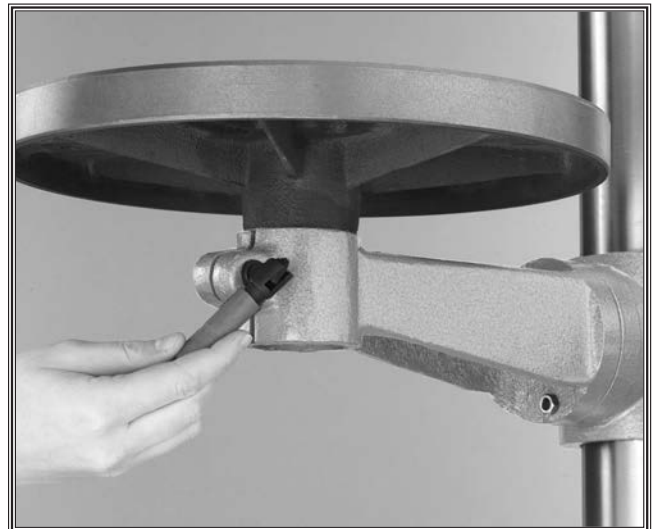

Figure 29. Unlock table for rotation.



Figure 30. Locating pin and nut.

OPERATIONS

Test Run



Figure 31. Hand poised over stop paddle.

Once assembly is complete and adjustments are done to your satisfaction, you are ready to test run the machine.

	<p>! WARNING Always wear safety glasses when operating drill press. Failure to comply may result in serious personal injury.</p>
--	---

Make sure the starting switch is off. The paddle is down for off. Make sure all the fasteners and lock handles are tight. Plug in the power cord. Pull the START paddle. Make sure that your finger is poised over the paddle, Figure 31, just in case there is a problem. The drill press should run smoothly, with little or no vibration or rubbing noises. Strange or unnatural noises require you to stop the machine, wait for it to stop moving, unplug the machine, investigate and correct

	<p>! WARNING DO NOT investigate problems or adjust the drill press while it is running. Wait until the machine is turned off, unplugged and all working parts have come to a complete stop before proceeding!</p>
--	--

before further operation. If source of an unusual noise or vibration is not readily apparent, contact our service department for help at 1-360-734-3482 or tech-sup-

	<p>! WARNING DO NOT investigate problems or adjust the drill press while it is running. Wait until the machine is turned off, unplugged and all working parts have come to a complete stop before proceeding!</p>
--	--

Drill Bit Changes

Care must be taken to secure the bit firmly in place. When changing bits, proceed as follows:

1. Disconnect the machine from the power source.
2. Open the chuck wide enough to accept a new bit.
3. Install the bit so the chuck jaws will grab as much of the bit shank as it can. **Figure 32.** Do not allow the chuck to grab the fluted body of the drill bit. Make sure small drill bits do not get trapped between the edges of two jaws.
4. Tighten the chuck with the chuck key using any of the three key end locations. **Figure 33.**
5. Remove the chuck key and reconnect the power source.
6. Reverse steps to remove the drill bit.



Figure 32. Installing bit.



Figure 33. Chuck key engaged.

MAINTENANCE

General

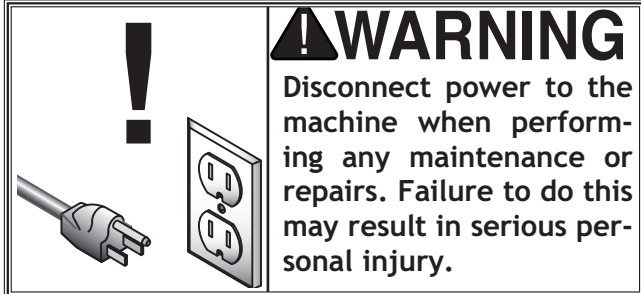

! WARNING
 Disconnect power to the machine when performing any maintenance or repairs. Failure to do this may result in serious personal injury.

Regular periodic maintenance on your Model W1680 Drill Press will ensure its optimum performance. Make a habit of inspecting your drill press each time you use it. Check for the following conditions and repair or replace when necessary.

1. Loose mounting bolts.
2. Worn switch.
3. Worn or damaged cords and plugs.
4. Damaged drive belts.
5. Any other condition that could hamper the safe operation of this machine.

Table And Base

Tables can be kept rust-free with regular applications of products like Boeshield® T-9. For long term storage you may want to consider products like Kleen Bore's Rust Guardit™.

Lubrication

Since all bearings are shielded and permanently lubricated, simply leave them alone until they need to be replaced. Do not lubricate them.

For other items on this machine, such as the quill, table and column, an occasional application of light machine oil is all that is necessary. Before applying lubricant, clean off sawdust and metal chips.

Your goal is to achieve adequate lubrication. Too much lubrication will attract dirt and sawdust. Various parts of your machine could lose their freedom of movement as a result.

CLOSURE

The following pages contain general machine data, parts diagrams/lists and warranty/return information for your Shop Fox® Model W1680 17" Drill Press.

If you need parts or help in assembling your machine, or if you need operational information, we encourage you to call our Service Department. Our trained service technicians will be glad to help you.

If you have comments dealing specifically with this manual, please write to us using the address in the General Information. The specifications, drawings, and photographs illustrated in this manual represent the Model W1680 as supplied when the manual was prepared. However, due to Woodstock International, Inc.'s policy of continuous improvement, changes may be made at any time with no obligation on the part of Woodstock International, Inc. Whenever possible, though, we send manual updates to all owners of a particular tool or machine that have registered their purchase with our warranty card. Should you receive one, add the new information to this manual and keep it for reference.

We have included some important safety measures that are essential to this machine's operation. While most safety measures are generally universal, we remind you that each workshop is different and safety rules should be considered as they apply to your specific situation.

We recommend you keep this manual for complete information regarding Woodstock International, Inc.'s warranty and return policy. Should a problem arise, we recommend that you keep your proof of purchase with your manual. If you need additional technical information relating to this machine, or if you need general assistance or replacement parts, please contact the Service Department at 1-360-734-3482 or tech-support@woodstockint.com.

Additional information sources are necessary to realize the full potential of this machine. Trade journals, woodworking magazines, and your local library are good places to start.

⚠ WARNING

As with all power tools, there is danger associated with the Model W1680 Drill Press. Use the tool with respect and caution to lessen the possibility of mechanical damage or operator injury. If normal safety precautions are overlooked or ignored, injury to the operator or others in the area is likely.

The Model W1680 was specifically designed for drilling and drum sanding operations. **DO NOT MODIFY AND/OR USE THIS DRILL PRESS FOR ANY OTHER PURPOSE. MODIFICATIONS OR IMPROPER USE OF THIS TOOL WILL VOID THE WARRANTY.** If you are confused about any aspect of this machine, **DO NOT** use it until you have answered all your questions.

CLOSURE



⚠ WARNING

Keep your shop "Kids Safe". Always remove the switch safety key when drill press is not in use. Serious injury may occur.

⚠ DANGER

Disconnect power from machine before performing any electrical service. Failure to do this will result in a shock hazard leading to injury or death.

W1680 17" Drill Press Wire Diagram

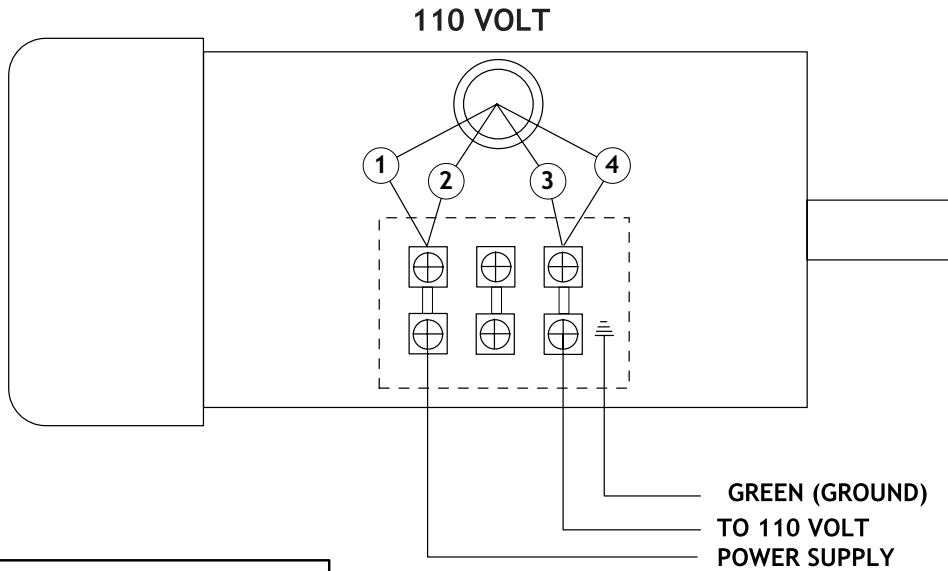

NOTE: THE WIRES FROM THE POWER SUPPLY, BESIDES THE GREEN GROUND WIRE, ARE INTERCHANGABLE, THEREFORE COLORS ARE NOT SPECIFIED.

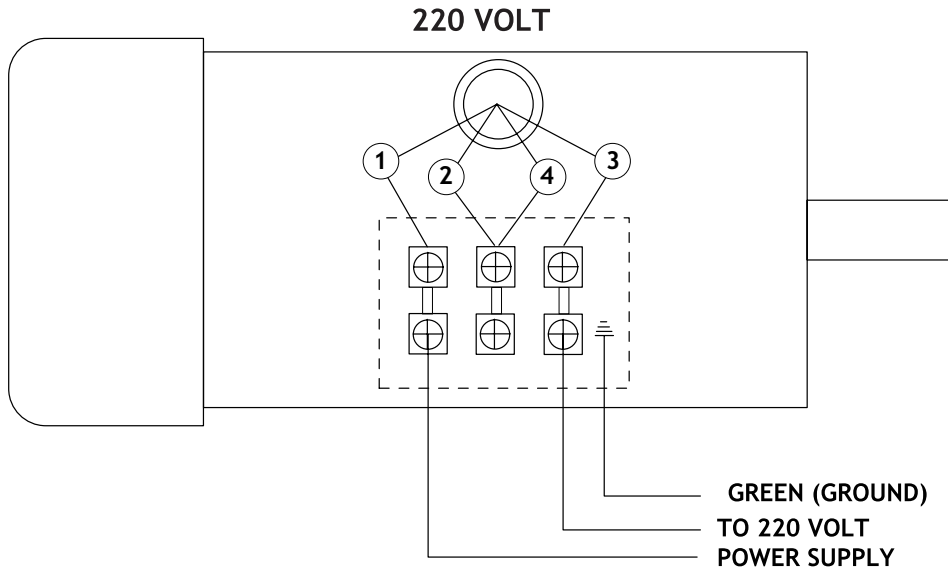

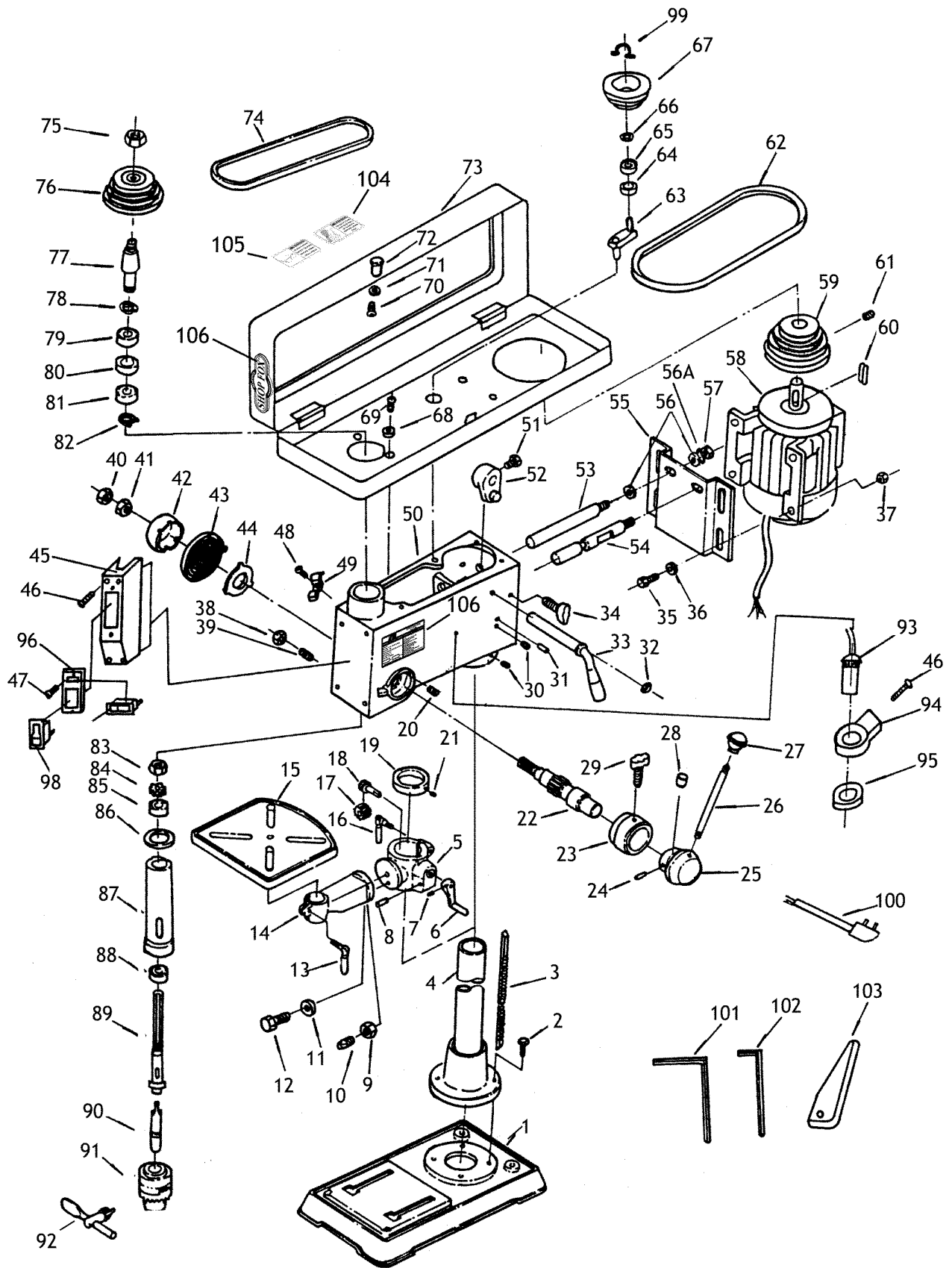

REF	PART #	DESCRIPTION
01	X1680001	BASE
02	XPB27M	HEX BOLT M12-1.75 X 30
03	X1680003	RACK
04	X1680004	COLUMN
05	X1680005	TABLE BRACKET
06	X1680006	HANDLE
07	X1680007	SET SCREW
08	X1680008	SHAFT
09	X1680009	NUT
10	X1680010	PIN
11	X1680011	WASHER
12	X1680012	BOLT
13	X1680013	TABLE BOLT
14	X1680014	TABLE ARM BRACKET
15	X1680015	TABLE
16	X1680016	CLAMP BOLT
17	X1680017	GEAR
18	X1680018	WORM GEAR
19	X1680019	RACK RING
20	X1680020	PIN STOP
21	XPSS01M	SET SCREW M6-1 X 10
22	X1680022	FEED SHAFT
23	X1680023	SCALE RING
24	X1680024	ROLL PIN
25	X1680025	HANDLE BODY
26	X1680026	HANDLE

REF	PART #	DESCRIPTION
27	X1680027	KNOB
28	X1680028	KEY
29	X1680029	LOCK KNOB
30	X1680030	SET SCREW
31	X1680031	ROLL PIN
32	X1680032	SNAP RING
33	X1680033	SHIFTER BAR
34	X1680034	LOCK KNOB
35	X1680035	BOLT
36	X1680036	WASHER
37	X1680037	NUT
38	X1680038	NUT
39	X1680039	SPECIAL SET SCREW
40	X1680040	NUT
41	X1680041	NUT
42	X1680042	SPRING CAP
43	X1680043	SPRING-TORSION
44	X1680044	SPRING COVER
45	X1680045	SWITCH BOX
46	X1680046	SCREW
47	XPS38M	PHLP HD SCR M4-.7 X 10
48	X1680048	SCREW
49	X1680049	CORD CLAMP
50	X1680050	HEAD CASTING
51	X1680051	BOLT
52	X1680052	SHIFTER



REF	PART #	DESCRIPTION
53	X1680053	SLIDE BAR
54	X1680054	SLIDE BAR
55	X1680055	MOTOR BASE
56	X1680056	WASHER
56A	X1680056A	SPRING WASHER
57	X1680057	NUT
58	X1680058	MOTOR
59	X1680059	MOTOR PULLEY
60	X1680060	KEY
61	X1680061	SET SCREW
62	X1680062	V-BELT
63	X1680063	CENTER SHAFT
64	XP6202	BALL BEARING 6202ZZ
65	XP6202	BALL BEARING 6202ZZ
66	X1680066	INTERNAL RETAINING RING
67	X1680067	CENTER PULLEY
68	X1680068	WASHER
69	X1680069	SCREW
70	XPS09M	PHLP HD SCR M5-.8 X 10
71	XPW02M	FLAT WASHER 5MM
72	X1680072	KNOB
73	X1680073	PULLEY COVER
74	X1680074	V-BELT
75	X1680075	PULLEY NUT
76	X1680076	SPINDLE PULLEY
77	X1680077	INSERT PULLEY
78	X1680078	INTERNAL RETAINING RING
79	XP6207	BALL BEARING 6207ZZ

REF	PART #	DESCRIPTION
80	X1680080	SPACER
81	XP6207	BALL BEARING 6207ZZ
82	X1680082	INTERNAL RETAINING RING
83	X1680083	ROUND NUT
84	X1680084	TAB WASHER
85	XP6206	BALL BEARING 6206ZZ
86	X1680086	RUBBER WASHER
87	X1680087	SPINDLE SLEEVE
88	XP6207	BALL BEARING 6207ZZ
89	X1680089	SPINDLE
90	X1680090	ARBOR
91	X1680091	CHUCK
92	X1680092	CHUCK KEY
93	X1680093	LIGHT SOCKET
94	X1680094	LIGHT BASE
95	X1680093	SCREW
96	X1680096	SWITCH BASE
97	X1680097	SWITCH (LIGHT)
98	X1680098	SWITCH (MOTOR)
99	X1680099	SNAP RING
100	X1680100	PIN
101	XPAW04M	ALLEN® WRENCH 4MM
102	XPAW05M	ALLEN® WRENCH 5MM
103	X1680103	WEDGE
104	X1680104	LONG HAIR SAFETY LABEL
105	X1680105	GLASSES SAFETY LABEL
106	X1680106	MACHINE ID LABEL
107	X1680107	MACHINE LABEL

WARRANTY CARD

Name _____
Street _____
City _____ State _____ Zip _____
Phone Number _____ E-Mail _____ FAX _____
MODEL # _____

The following information is given on a voluntary basis and is strictly confidential.

1. Where did you purchase your Shop Fox® machine?
Store? _____ City? _____
2. How did you first learn about us?
___Advertisement _____Friend
___Mail order Catalog _____Local Store
___World Wide Web Site
___Other _____
3. Which of the following magazines do you subscribe to.
___American Woodworker _____Today's Homeowner
___Cabinetmaker _____Wood
___Family Handyman _____Wooden Boat
___Fine Homebuilding _____Woodshop News
___Fine Woodworking _____Woodsmith
___Home Handyman _____Woodwork
___Journal of Light Construction _____Woodworker
___Old House Journal _____Woodworker's Journal
___Popular Mechanics _____Workbench
___Popular Science _____American How-To
___Popular Woodworking
___Other _____
4. Which of the following woodworking/remodeling shows do you watch?
___Backyard America _____The New Yankee Workshop
___Home Time _____This Old House
___The American Woodworker _____Woodwright's Shop
___Other _____
5. What is your annual household income?
___\$20,000-\$29,999 _____\$60,000-\$69,999
___\$30,000-\$39,999 _____\$70,000-\$79,999
___\$40,000-\$49,999 _____\$80,000-\$89,999
___\$50,000-\$59,999 _____\$90,000 +
6. What is your age group?
___20-29 _____50-59
___30-39 _____60-69
___40-49 _____70 +
7. How long have you been a woodworker?
___0 - 2 Years _____8 - 20 Years
___2 - 8 Years _____20+ Years
8. How would you rank your woodworking skills?
___Simple _____Advanced
___Intermediate _____Master Craftsman
9. How many Shop Fox® machines do you own? _____
10. What stationary woodworking tools do you own? Check all that apply.
___Air Compressor _____Panel Saw
___Band Saw _____Planer
___Drill Press _____Power Feeder
___Drum Sander _____Radial Arm Saw
___Dust Collector _____Shaper
___Horizontal Boring Machine _____Spindle Sander
___Jointer _____Table Saw
___Lathe _____Vacuum Veneer Press
___Mortiser _____Wide Belt Sander
___Other _____
11. Which benchtop tools do you own? Check all that apply.
___1" x 42" Belt Sander _____6" - 8" Grinder
___5" - 8" Drill Press _____Mini Lathe
___8" Table Saw _____10" - 12" Thickness Planer
___8" - 10" Bandsaw _____Scroll Saw
___Disc/Belt Sander _____Spindle/Belt Sander
___Mini Jointer
___Other _____
12. Which portable/hand held power tools do you own? Check all that apply.
___Belt Sander _____Orbital Sander
___Biscuit Joiner _____Palm Sander
___Circular Saw _____Portable Planer
___Detail Sander _____Saber Saw
___Drill/Driver _____Reciprocating Saw
___Miter Saw _____Router
___Other _____
13. What machines/supplies would you like to see?
___12" Table Saw _____Radial Arm Saw
___12" Jointer _____Panel Saw
___Combination Planer/Joiner _____Brass Hardware
___Paint & Finnish Supplies _____Lumber
___Contractor's Supplies _____Power Tools
___other _____
14. What new accessories would you like Woodstock International to carry?

15. Do you think your purchase represents good value?
___Yes _____No
16. Would you recommend Shop Fox® products to a friend?
___Yes _____No
17. Comments: _____

CUT ALONG DOTTED LINE

FOLD ALONG DOTTED LINE

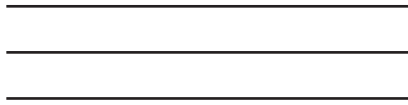

Place
Stamp
Here



WOODSTOCK INTERNATIONAL, INC.
P.O. BOX 2309
BELLINGHAM, WA 98227-2309



FOLD ALONG DOTTED LINE

TAPE ALONG EDGES--PLEASE DO NOT STAPLE