

3D Printer User Manual

Aquila X2

Note: Each device must be tested before leaving factory. If there are some residues in extruder or some tiny scratches on the build plate, it is normal and won't affect the printing quality.

Content

Thank you for choosing Voxelab products. For your convenience, please read the manual carefully before using, and operate the device accordingly. Voxelab team is always at your service, reach us at any time if you need any assistance.

Official website: www.voxelab3dp.com

(get tutorials, software, firmware, device maintenance and relevant information)

Email: support@voxelab3dp.com

A

Notes

Product Introduction

Mechanism Parts

Spare Parts

B

Assembly Guide

C

Operation Guide

Start Printing

Wire connection

Printing Notice

Trouble Shooting

Notes

1. Do not make any modifications to the device. To avoid personal injury or property damage please ensure your operation as followed as the Guide.
2. Dress properly. Do not wear loose clothing or jewelry. Keeping your hair, clothing and gloves away from moving parts.
3. Do not directly touch the nozzle and build plate to avoid high-temperature burn.
4. Do not operate the printer in flammable liquid, gas or dust environment (The high temperature generated by printer operation may react with dust, liquid, and flammable gas in the air to cause a fire.)
5. Do not display the printer in unstable environment. The printer quality may be affected.
6. Children and untrained personnel are not allowed to operate the printer alone.
7. Operate the device in a well-ventilated environment. Some materials may produce odors during the printing process.
8. Do not manually move the nozzle and printing platform mechanism while booting up, otherwise the device will be damaged.
9. Never use the device for illegal activities.
10. Never use the device to make any food storage vessels.
11. Never put the model into your mouth.
12. Lower the build plate before loading/unloading filament. The distance between the nozzle and build plate should be kept for at least 50mm.
13. Keep the printer with regular maintenance, to wipe with a dry cloth to remove dust and adhered printing items.



Please pay attention to the sharp edges and corners of the profile.

Product Introduction

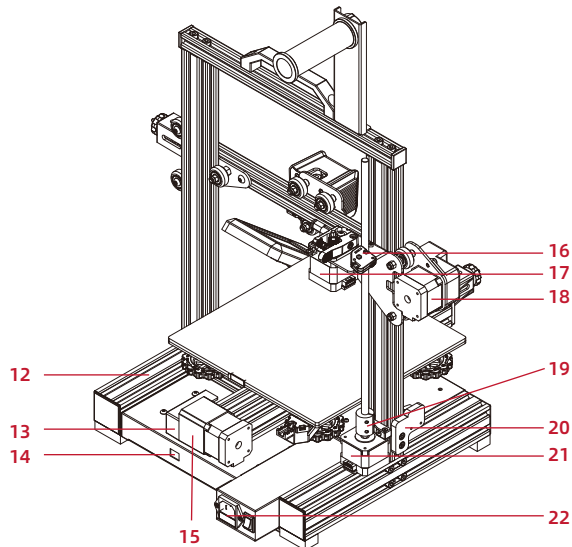
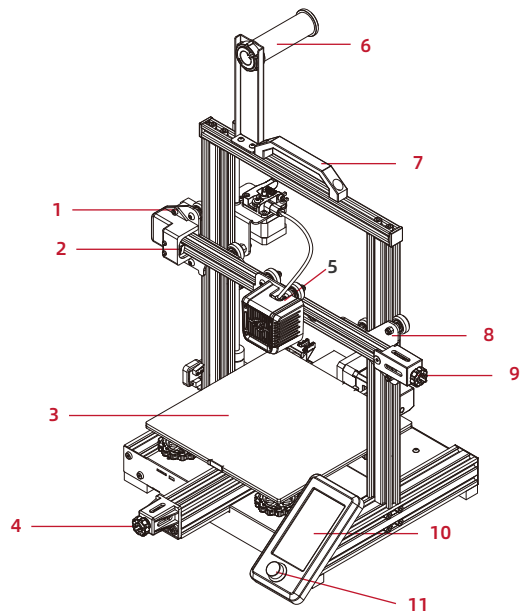

- 1. XE-axis kit
- 2. X-axis limit switch
- 3. Build plate
- 4. Y-axis tensioner
- 5. Extruded kit
- 6. Material rack and spool holder

- 7. Handle
- 8. Z-axis passive block
- 9. X-axis tensioner
- 10. Screen
- 11. Knob switch
- 12. Machine base

- 13. Y-axis limit switch
- 14. Voltage regulator
- 15. Y-axis motor
- 16. Filament detector
- 17. E-axis motor
- 18. X-axis motor

- 19. Coupling
- 20. Z-axis limit switch
- 21. Z-axis motor
- 22. Power switch and socket

Equipment Parameters

Model	Voxelab Aquila X2
Print size	220*220*250mm
Forming technology	FDM
Number of nozzle	1
Layer thickness	0.1mm - 0.4mm
Nozzle diameter	Standard 0.4mm
XY axis precision	±0.2mm
Filament	φ1.75mm PLA
File format	STL / OBJ / AMF
Working mode	Memory card offline printing / USB connection printing
Compatible slicing software	Cura / Simplify 3D / VoxelMaker
Power specification	Input: AC 115/230V 50/60Hz Output: DC 24V
Total power	350W
Hotbed temperature	≤100°C
Nozzle temperature	≤250°C
Resume printing function	Yes
Filament sensor	Yes
Dual z-axis screws	No
Language switch	English / Chinese
Computer operating system	Windows 7/10 / Mac OS
Print speed	≤180mm/s, 30-60mm/s normally

Mechanism Parts

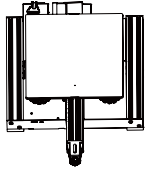

Printer base *1

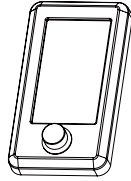

Screen kit *1

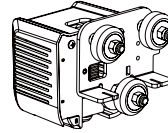

Extruder kit *1

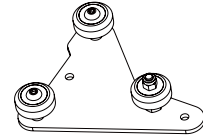

Z-axis passive block *1

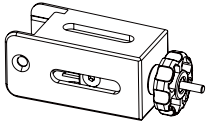

X-axis tensioner *1

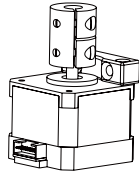

Z-axis motor kit *1

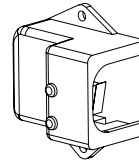

X-axis limit switch kit *1

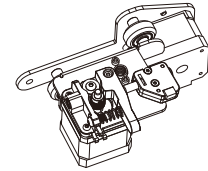

XE axis kit *1



Z-axis profile(left) *1

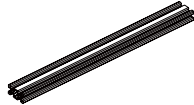

Z-axis profile(right) *1

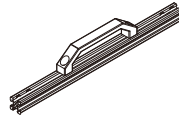

Gantry profile *1

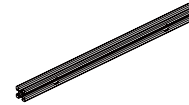

X-axis profile *1

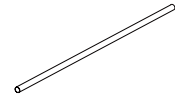

T-shaped screw rod *1

Spare Parts

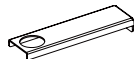

Material rack *1

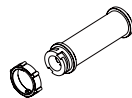

Material pipe and nut *1

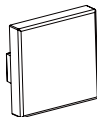

2020 profile cover *2



Synchronous belt *1



Remove tool *1



Cable tie *1



Needle *1



Storage card and card reader *1



M6 Pneumatic joint *2



Power cable *1



Wrenches and screwdrivers *1

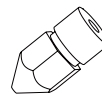

Nozzle *1

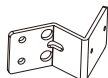

Screen bracket *1



Hexagon socket countersunk head screw M4x20 *2



Hexagon socket flat round head screw M4x6 *2



Hexagon socket flat round head screw M5x14 *6

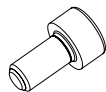

Hexagon socket head screw M4x8 *2



Hexagon socket head spring washer combination screw M5x45 *5

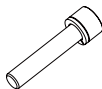

Hexagon socket head spring washer combination screw M5x25 *5

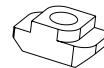

M4 T nuts *2



Filament *1



Hexagon socket flat round head screw M5x8 *2



Hexagon socket head tapping screw ST2.9x9.5 *2

1

Installation of Z-axis limit switch kit and Z-axis profiles

Installation video can be found on [Voxelab Youtube channel](#)

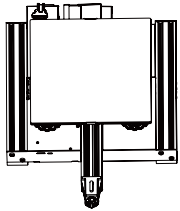

Printer base *1

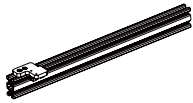

Z-axis profile(left) *1

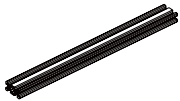

Z-axis profile(right) *1



Hexagon socket head spring washer combination screw
M5x45 *4

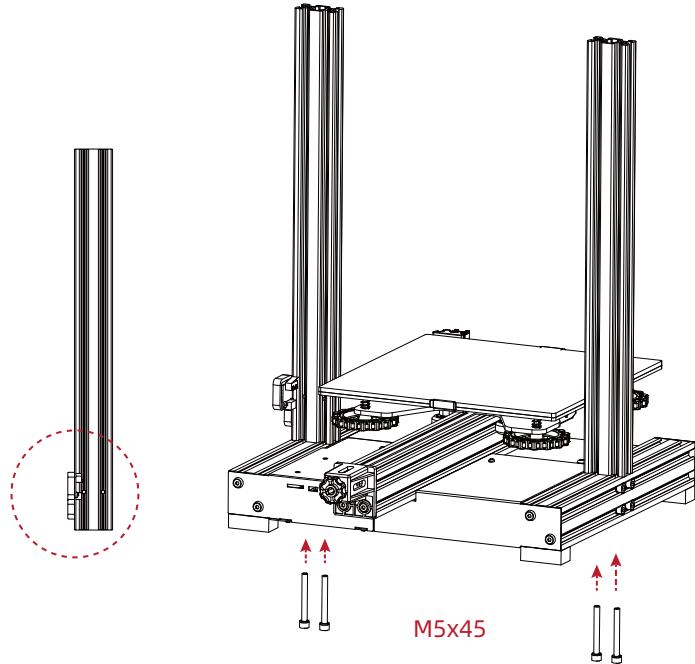

Step: Use the four pieces screws M5x45 to fix Z-axis with the base.

2

Install Z-axis motor kit and T-shaped screw rod

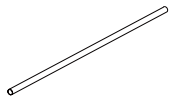

T-shaped screw rod *1

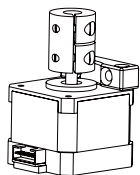

Z-axis motor kit *1



Hexagon socket countersunk head screw M4x20 *2

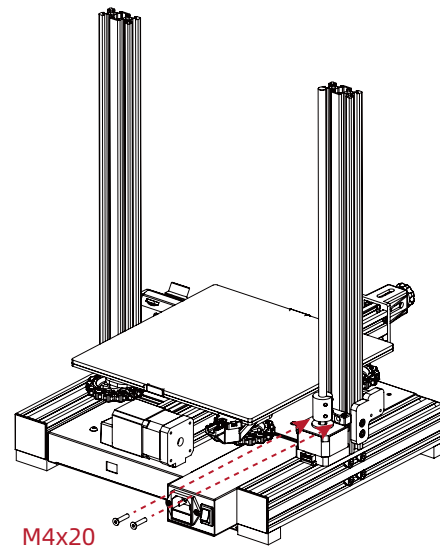
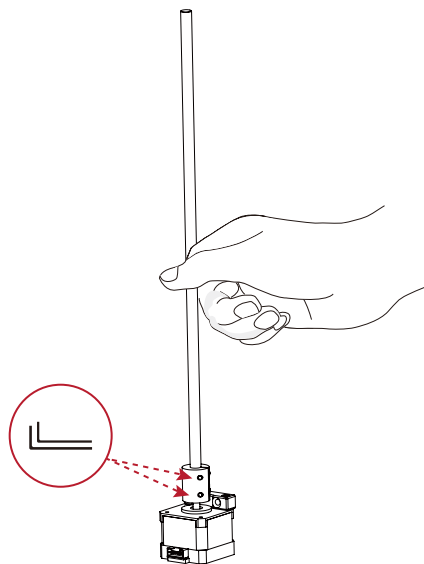

Step: Unlock the nuts on Z-axis motor kit firstly, then insert the T-shaped screw road into the Z-axis motor kit, finally lock the nut. (as showed above).

3

Install pneumatic joint, XE-axis kit

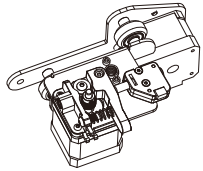

XE axis kit *1



X-axis profile *1



M6 Pneumatic joint *1

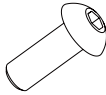

Hexagon socket flat round head screw M5x14 *2

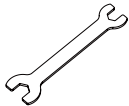

Open-end wrench *1

X-axis profile

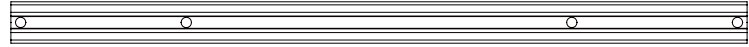

Step 1: Insert the M6 pneumatic joint to the connector of the XE axis kit, then use open-end wrench to screw them together.

Step 2: Lock the XE axis kit onto the X axis profile with M5x14 screws.

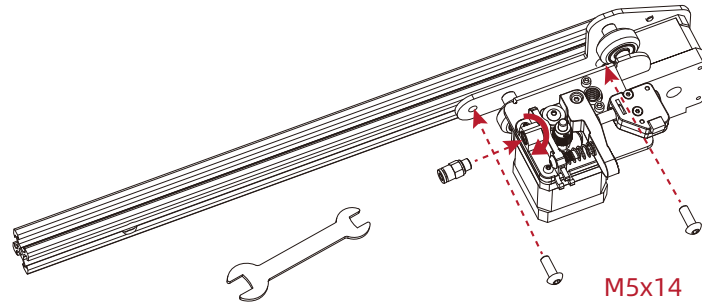

M5x14

4

Install synchronous belt, extruder kit and Z-axis passive block

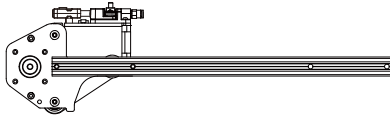

X axis kit

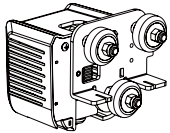

Extruder kit *1

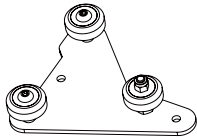

Z-axis passive block *1



Synchronous belt *1

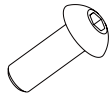

Hexagon socket flat round head screw M5x14 *1

Put the synchronous belt into the profile along the v-wheel of the extruder kit. Mount the extruder kit onto the X axis kit. The belt is on the top of the profile and under the v wheel when pushing it into the middle.

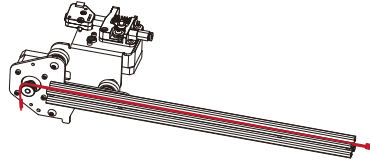

The highlighted red stripe refers to synchronous belt.

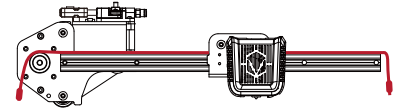

Install Z axis passive block with M5x14.

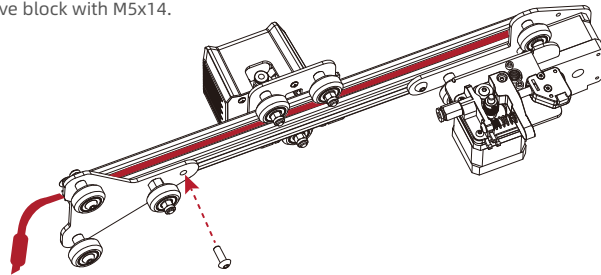

M5x14

5

Install X-axis Tensioner



X-axis tensioner *1

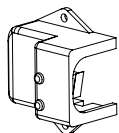

X-axis limit switch kit *1

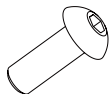

Hexagon socket flat round head screw M5x14 *2

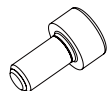

Hexagon socket head screw M4x8 *2

1. Disassemble the X-axis tensioner.

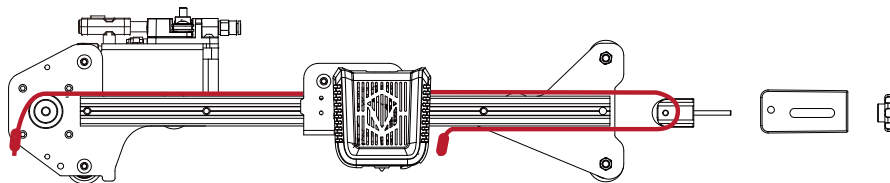
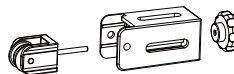

2. Insert the synchronous belt into the tensioner block, reassemble the X axis tensioner, make sure that the belt connects with the tensioner.

3. Tighten it with a plastic hand screw nut, lock Z-axis passive block with ①M5x14 screw first, and then lock the ②M5x14 screw.

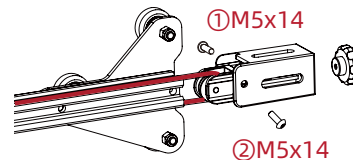

Attention: During the current operation, please do not tighten the X-axis tensioner screws with too much force.

Install X-axis Tensioner

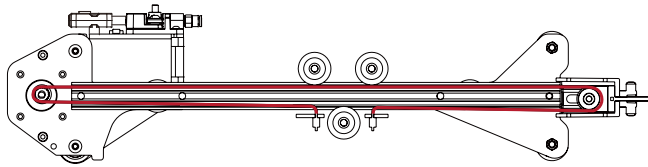

4. Insert the synchronous belt buckle into the sheet metal slot at the back of the extruder and tighten X-axis tensioner completely.



5. Lock the X-axis limit assembly on the XE axis with two M4x8 screws.

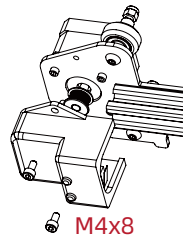

6

Install the X-axis moving kit and adjust the tightness of X-axis and Y-axis tensioners

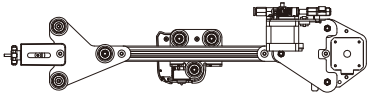

Take the first step: assembled components

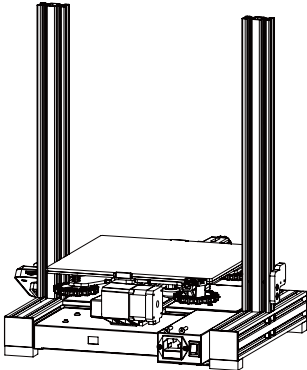

Take the second step: assembled components

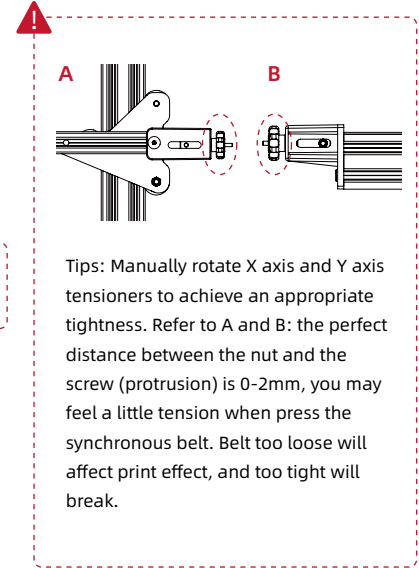
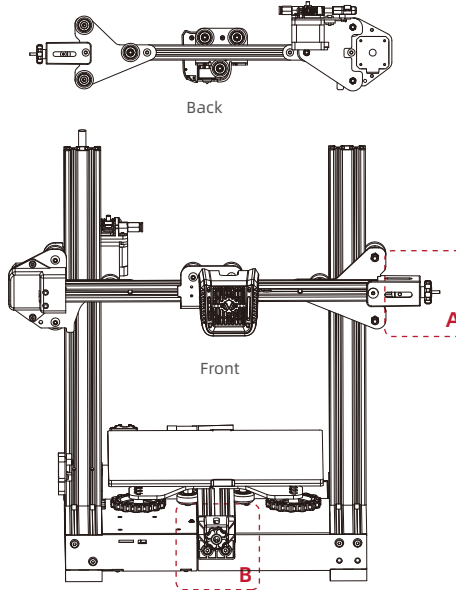

Step:

1. Implant the X axis kit along the V-wheel into the two ends of Z axis profile (as showed in the above figure).
2. After installation, move the extruder left and right to check belt's tension. It is recommended that the extruder can touch X-axis sensor and the belt has elasticity.

7

Install the gantry profile, screen kit



Gantry profile *1



Hexagon socket head spring washer combination screw M5x25 *4



Hexagon socket flat round head screw M5x8 *2



Hexagon socket head tapping screw ST2.9x9.5 *2

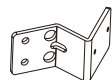

Screen bracket *1

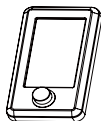

Screen kit *1

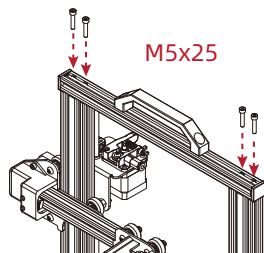

1. Fix the gantry profile on the upper end of the Z axis with four pieces screws M5x25.

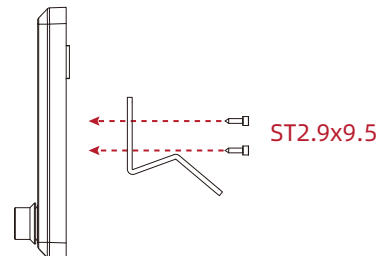

2. Lock screen bracket and screen kit with two pieces screws ST2.9*9.5

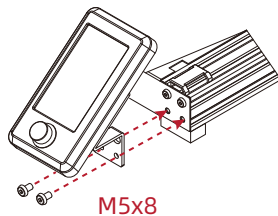

3. Lock the assembled screen kit onto printer base side using two pieces screws M5*8.

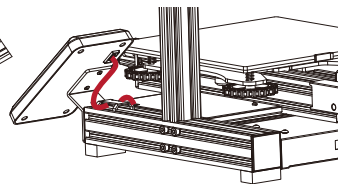

4. Connect the display screen kit with screen cable.

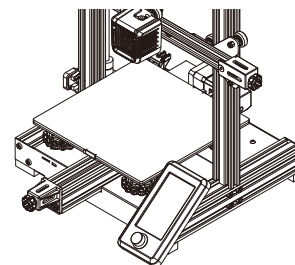

8

Install spool holder and gantry cover

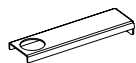

Material rack *1

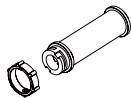

Material pipe and nut *1

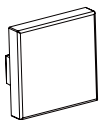

2020 profile cover *2



Hexagon socket flat round head screw M4x6 *2

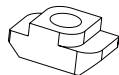

M4 T nuts *2

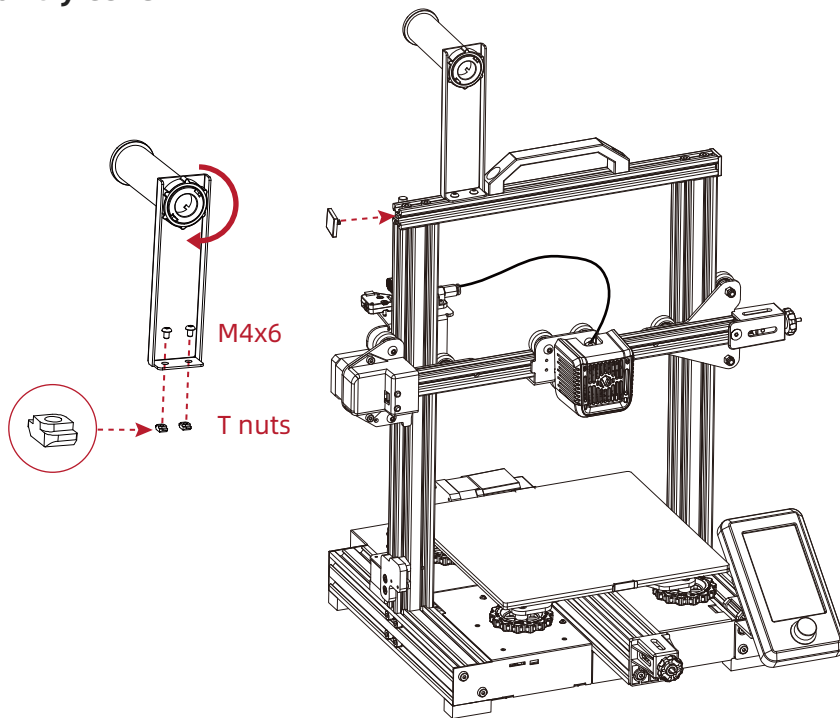

Step: Put M4x6 and T nuts into the material rack (as showed), place spool holder on the rack and fix on profile with screws (as showed); Then insert 2020 profile cover on both side.

9

Wire connection

1. Insert the teflon tube into the pneumatic connector.
2. Connect the yellow-labeled cable on 6 pin (4 wires) port to E-axis stepper motor.
3. Connect the yellow-labeled cable on 6 pin (4 wires) port to X-axis stepper motor.
4. Connect the yellow-labeled cable on 3 pin (2wires) port to X-axis limit switch.
5. Connect the cable on 3 pin port to filament detector.
6. Connect the yellow-labeled cable on 3 pin port to Z-axis limit switch.
7. Connect the yellow-labeled cable on 6 pin port to Z-axis motor.
8. Plug in the power cord (as showed) and toggle the switch to turn on the power.



Power cable *1

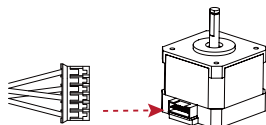

X, E, Z-axis motor port

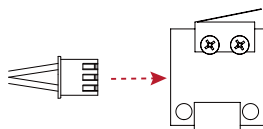

X, Z-axis limit switch

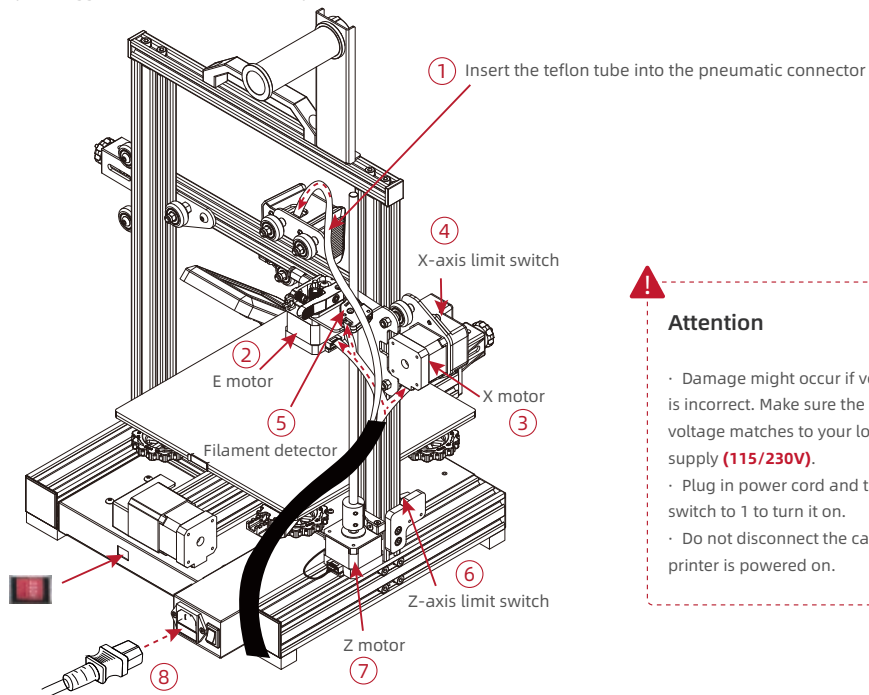

Attention

- Damage might occur if voltage setting is incorrect. Make sure the current input voltage matches to your local power supply (**115/230V**).
- Plug in power cord and turn power switch to 1 to turn it on.
- Do not disconnect the cables when the printer is powered on.

10 Bed Leveling

Leveling operation video can be found on Voxelab Youtube channel

Check the steadiness of the build plate before leveling. If the build plate is unsteady, please use open-end wrench to adjust the v-wheel to steady it.

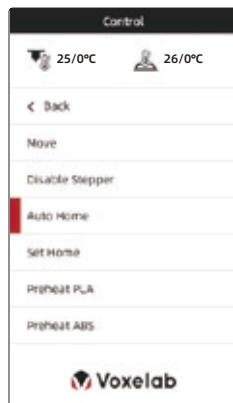
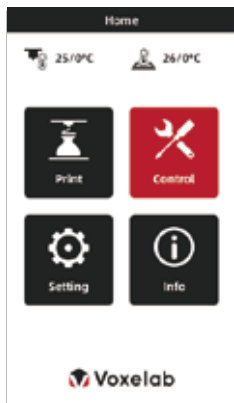
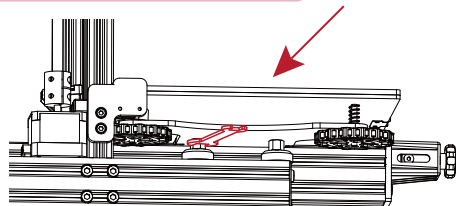

Choose [Auto home] first to ensure the extruder in the home position; then choose [Disable steppers] to close the motors.



Make sure extruder homing has finished before closing the motors.
Do not touch Teflon tube and nozzle cable during bed leveling.

Note: The UI information is only for reference, the actual UI may be different.

Bed Leveling

1. Move the extruder on the top of the leveling nut. Screw the nut and adjust the distance between the nozzle and the build plate. The distance is around 0.1mm. (Thickness of a piece of A4 paper)
2. Use a piece of A4 paper to assist in leveling, so that the nozzle can just scratch the A4 paper lightly. Adjust the leveling nuts on the four sides in turn until you can feel the slight resistance from the nozzle when pulling the A4 paper.
3. Test the distance between the nozzle and the print platform is enough or not. Repeat the above steps 1-2 times if necessary.

Note: If adjusting rotating nuts cannot make the nozzle touch the build plate, the position of the z-axis limit switch may be too high. Adjust accordingly.

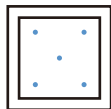
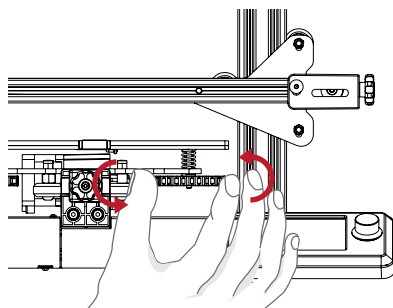

After adjusting the upper position of the 4 nuts, check the center position again.

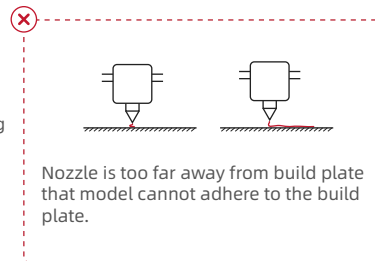
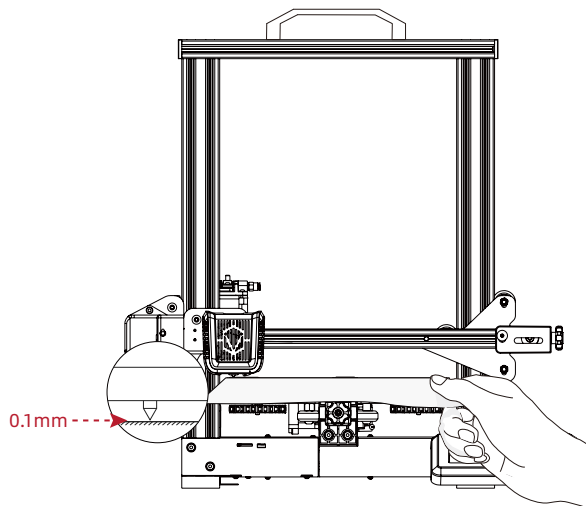

Nozzle is too far away from build plate that model cannot adhere to the build plate.

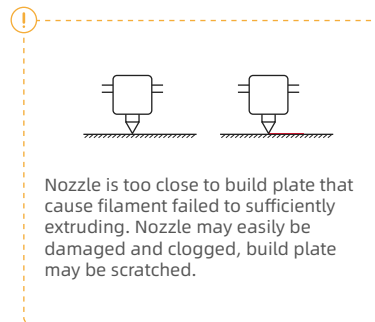

Nozzle is too close to build plate that cause filament failed to sufficiently extruding. Nozzle may easily be damaged and clogged, build plate may be scratched.

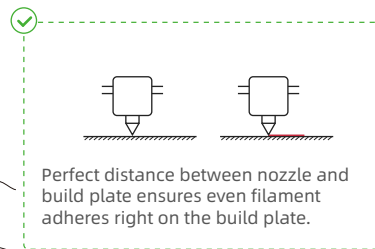

Perfect distance between nozzle and build plate ensures even filament adheres right on the build plate.

11

Preheat

Method 1

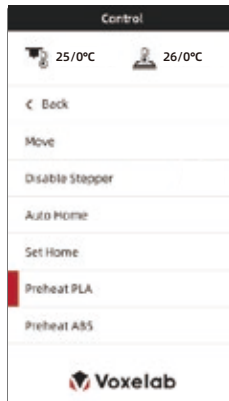

Note: The UI information is only for reference, the actual UI may be different.

Note: The printing preheat temperature for PLA and ABS filaments has been preset. PLA: nozzle temperature 200°C, hot bed temperature 60°C. ABS: nozzle temperature 240°C, hot bed temperature 70°C. For other materials or special printing environment print, you may adjust parameters under Control - Temperature.

Method 2

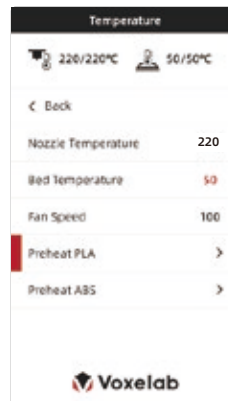
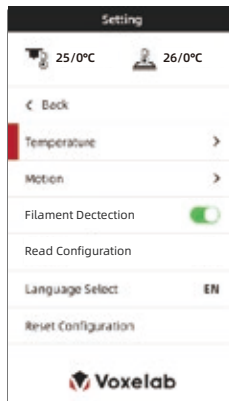
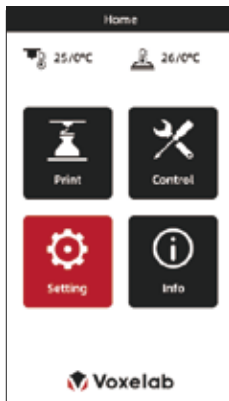

12

Load the filament

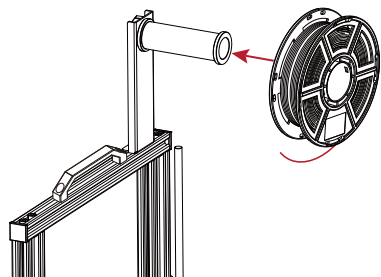

1. When waiting for the temperature to rise, please hang the filament on the material rack.

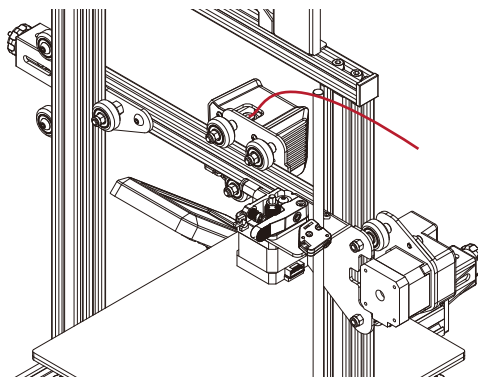

2. Press the spring to pull filament pass through (loose the spring and pull filament back and forth to see if extrusion pressure is too high or too low; adjust the screw on the force arm if the pressure is improper).
3. Pull filament into the wire tube; click <automatic input> button beneath the setting to send filament to the nozzle. Loading is completed when filament are extruded at the nozzle. Filament can be extruded to the nozzle manually when the printer is preheated.



For better printing, the end of filament recommended as showed in the figure.

Load the filament

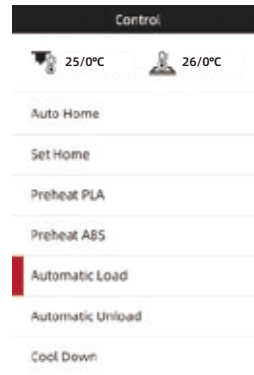
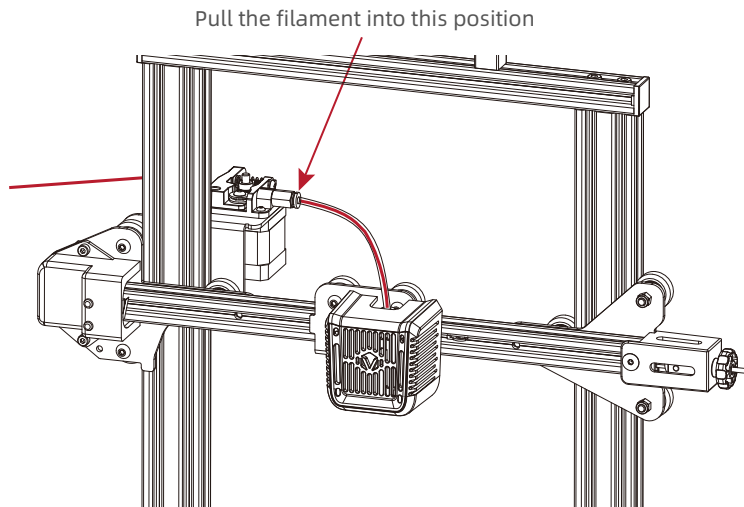

Replace the filament during printing

1. If filament in the nozzle, heat up the nozzle to 185°C+, draw out the filament to replace it.
2. To replace filament during the printing process, please adjust the printing speed to 10%, then replace it as introduced in Step 1.

13 Start printing

Please level build plate before printing, otherwise it will easily cause nozzle damage or clog, and build plate scratched.

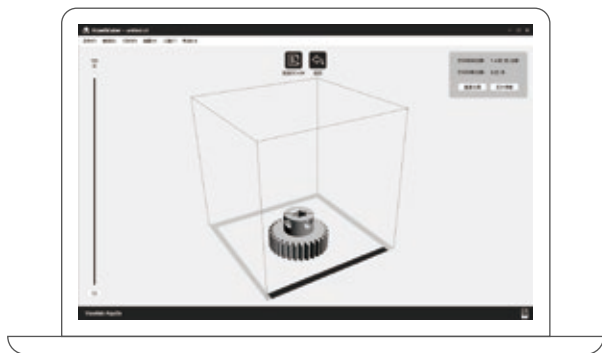

Install slicing software on your computer.

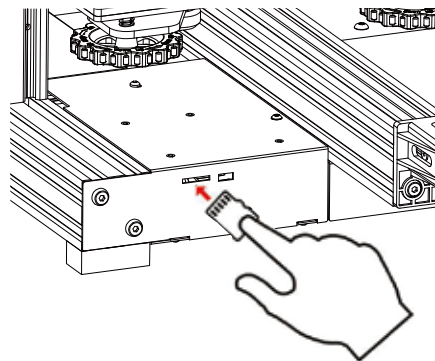

Insert the TF card, press the knob and set up the menu to print the file.



File names must be Latin letters or numbers, Chinese characters and other special symbols are unaccepted.

Start printing

Print

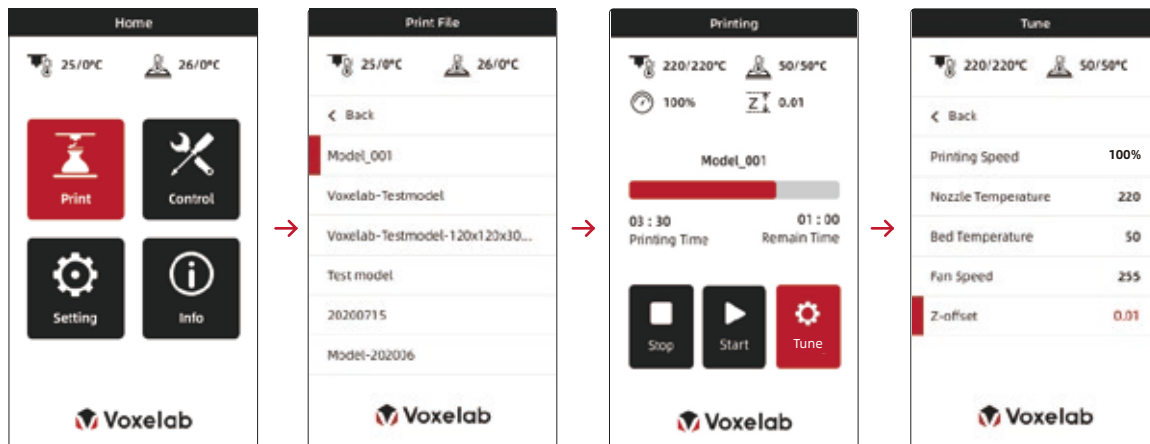

Note: When you notice the improper distance between the nozzle and the build plate during printing the first layer, please click Setting - Z axis offset to adjust the distance.

When the offset value is positive, the nozzle and the build plate get farther; When the offset value is negative, the nozzle and the build plate get closer.

Wiring connection

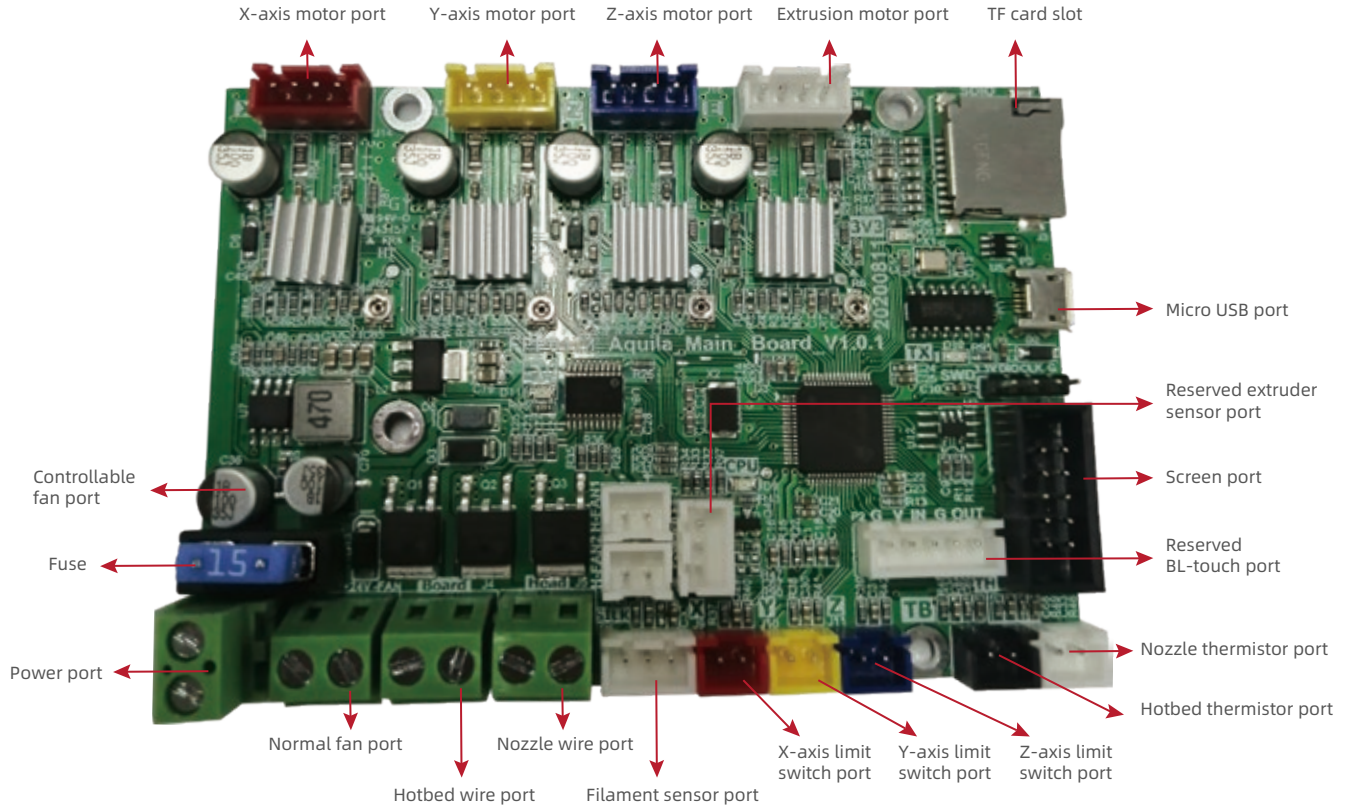



Printing notice

1. The adhesion of glass build plate may decrease after long time using. Please apply proper amount of glue to keep and improve the adhesion.
2. Warping issues may occur when print ABS filament in cold environment, you may use glue to enhance the adhesion. It's not recommended to print ABS filament at extremely low temperature environment, as print will easily fail with model break away from the build plate.
3. There is a certain quivering on the build plate during the printing which may cause the flatness to change. Thus please pay attention to the adhesion of the first layer when printing the second model; if the distance of build plate and nozzle is not right, please re-level it.
4. If prints' accuracy is not right, check the status of synchronous belt, adjust it if too loose or too tight. If synchronous belt is working correctly, check the transmission ratio under Setting. Turn up the transmission ratio if the size gets smaller, turns down the ratio if the size gets larger.
5. If the accuracy of Z-axis height dimension is not good enough, check out the compensation setting of Z-axis for precision compensation.
6. If the build plate shakes, adjust tightness of the pulley using a wrench and slowly slide the build plate to see whether all four wheels under it rotate. Stop moving the pulley only when the build plate is steady.
7. If XZ components shakes, adjust the distance between the pulley and the structural section properly using an open-end wrench; the wheel can be rotated by hand.
8. Optimal temperature for printing is 18~30°C. Print quality will be affected if ambient temperature is too high or too low.



Trouble shooting

Q: How to upgrade the firmwares?

- A:
1. Insert the TF card into the card reader
 2. Insert the card reader into the USB interface of the computer
 3. Create a new folder named firmware in TF card
 4. Copy the xx.bin file into the "firmware" folder
 5. Insert the TF card into the TF card socket of the machine
 6. Restart the machine

Q: How to get the firmwares?

- A: Enter the official website <www.voxelab3dp.com> and download them at the <Download Center>.

Q: What if the model warps or is unable to stick to the build plate?

- A:
1. Build plate temperature is too low, increase its temperature accordingly;
 2. Filament failed to adhere or bond on the build plate, use glues to enhance the adhesion;
 3. Distance between the build plate and the nozzle is too far or the build plate is not leveling enough, re-leveling the build plate accordingly.

Q: What if the accuracy of model is not good?

- A:
1. Please ensure the normal status of the synchronous belt, neither loose nor tight;
 2. Adjust the transmission ratio in the settings: turn up the transmission ratio if the size turns smaller and turn down the transmission ratio if the size turns larger.

Q: What if the screen turns dark?

- A:
1. Please check the wire of the screen and re-plug it;
 2. Refresh the firmware to see if the screen can back to normal. Contact the after-sales personnel if not.

Q: What if the build plate cannot be heated?

- A: Please check the digital display of the temperature. If the temperature improper, please replace the plate wires. Otherwise, please replace the heating wires.

Q: What if the nozzle cannot be heated?

- A:
1. Please check the digital display of the temperature; if the temperature displayed in error, replace the temperature sensor cable;
 2. If the temperature displayed normally, replace the heating cable.

Q: What if the axis cannot be moved?

- A:
1. Check the wire of the electric motor;
 2. Contact us by email listed.
Email: support@voxelab3dp.com



Trouble shooting

Q: What if the files on the TF card cannot be identified?

- A:
1. Clean and wipe the storage card
 2. Format the storage card
 3. Replace the storage card

Q: What if the files are garbled and cannot be read?

- A:
1. Change file name to English or numeric formats;
 2. Format of your sliced files is not compatible;
 3. Repair the model before slicing.

Q: What if the noise occurs for the return to zero device?

- A:
1. Check the return to zero sensor to see whether it has been knocked;
 2. Check the lines and see whether the noises could stop if the sensor is pressed by hand;
 3. Take the replacement method to check.

Q: Unable to resume printing from power failure?

- A: It might be caused by different TF card. Make sure you are using the same TF card before and after the power cut off.

Q: What if the offset occurs on the finished model?

- A:
1. Check the tightness of the synchronous belt and ensure it is correctly installed.
 2. Slice the model again
 3. Reduce print speed or adjust the acceleration value;
 4. Make sure operating temperature doesn't exceed its assigned set-point temperature 30°C.

Q: Damage occurs when turn on the 3D printer.

- A: It might be caused by dialing error from switch power supply, please check whether the voltage is set to the correct value. If the voltage is 110V and the power supply is 220V, damage will occur. Please select 110V/230V by switch before power on.

Q: Too much filament oozing?

- A:
1. Reduce print temperature by 5~10°C;
 2. Increase traveling speed, or increase the retraction length and speed.

Q: No filament coming out during printing?

- A:
1. The arm force of the feeding structure might be too tight to allow the filament out. Please adjust the arm force, neither too loose nor too tight.
 2. Lower the retraction length to avoid any abrasion.
 3. Check whether the extruder is clogged, clean it with the needle if necessary.



After-sales Service

< ASC20200701 >

Note: The one who sells you the printer should be responsible for your after-sales service.

1. Voxelab grants all end-users a 12-month limited warranty for all Voxelab 3D printers (except the Voxelab extruder) and a 3-month warranty for Voxelab FFF Extruder.
2. If Voxelab 3D printer fails during normal and proper use within the warranty period (judged by Voxelab engineers), Voxelab will provide users with free maintenance services or remote after-sales support.
3. The warranty period starts from the outbound date, or starts from the invoice date if clear and confirmed invoice is provided.
4. Voxelab will repair or replace only the defective parts with new or reconditioned parts or products that are functionally equivalent or superior to those originally supplied. If a part is repaired or replaced during the warranty period, the warranty period still remaining for the entire printer will apply to this part.

Parts Excluded from This Warranty

Build Tape	Plastic Scraper
Build Plat	Metal Scraper
USB Stick	Allen Wrench
USB Cable	Stamping Wrench
TF Card	Tools Bag
Card Reader	Accessories
Filament	Glue
Filament Spool	

* Voxelab extruder kit shall be purchased independently due to upgrading.

What is not covered

- Unable to provide valid After-sales Service Card or serial No.(Including but not limited to lost, alter or fuzzy cannot be confirmed);
- Damage(s) caused by improperly or incorrectly performed modifications, alterations or repair;
- Damage(s) due to operation under improper environment(damp, wet or other extreme weather);
- Exterior scratch or flaw caused by abrasion, aging or normal use;
- The warranty period of printer or part has expired;
- Damage(s) caused in service shops unauthorized by Voxelab;
- Damage(s) caused by improperly installation, use or operation;
- Damage(s) caused by abuse(overloaded working), misuses;
- Damage(s) caused by using unauthorized spare parts or poorquality filament ;
- Damage(s) caused by using 3rd party software;
- Damage(s) caused by force majeure(such as a lightning strike, fire, earthquake, floods or any other event beyond human control);
- Damage(s) caused by using 3rd party parts;



After-sales Service Registration Form

Series No.: _____ Purchase from: _____

Fault Description: _____

Tel.: _____ Contact: _____

Add.: _____

- ❗ Please fill in this form carefully, cut out this form and mail it back to Voxelab together with the printer, or download this form from www.voxelab3dp.com, fill in this form and mail it to aftersales@voxelab3dp.com. After-sales service shall not be provided without this form.
- ❗ Please contact your printer's reseller to get After-sales service help if your printer is not purchased on official Voxelab website.

Physical objects and final images might be distinct from the user manual due to differences between printer models.
Voxelab reserves final explanation rights.



Address: Xianyuan Road NO.518. Wucheng District, Jinhua, Zhejiang, China.

Official Website: www.voxelab3dp.com

E-mail: support@voxelab3dp.com



Voxelab



Voxelab



voxelab3dp



Voxelab



Voxelab 3D Printing

