

# PARTS MANUAL



**MODEL QP-301TY**

**MODEL QP-301TA**

**TRASH PUMPS**



**(YANMAR L60AEP/ROBIN EH25 GASOLINE ENGINES)**

Revision #0 (09/08/10)

To find the latest revision of this  
publication, visit our website at:  
[www.multiquip.com](http://www.multiquip.com)



**THIS MANUAL MUST ACCOMPANY THE EQUIPMENT AT ALL TIMES.**

 **WARNING** 

**CALIFORNIA — Proposition 65 Warning**

Gasoline engine exhaust and some of its constituents are known to the State of California to cause cancer, birth defects and other reproductive harm.

**QP-301TY/QP301TA**

Proposition 65 Warning ..... 2  
Table of Contents ..... 3  
Parts Ordering Procedures ..... 4  
Explanation of Codes in Remarks Column ..... 6  
Suggested Spare Parts ..... 7

**COMPONENT DRAWINGS**

Pump Assembly ..... 8-11  
Terms and Condition of Sale — Parts ..... 12

**NOTICE**

*Specification and part number are subject to change without notice.*

# PARTS ORDERING PROCEDURES

## Ordering parts has never been easier! Choose from three easy options:

Effective:  
January 1<sup>st</sup>, 2006



### Order via Internet (Dealers Only):

Order parts on-line using Multiquip's SmartEquip website!

- View Parts Diagrams
- Order Parts
- Print Specification Information



If you have an MQ Account, to obtain a Username and Password, E-mail us at: [parts@multiquip.com](mailto:parts@multiquip.com).

To obtain an MQ Account, contact your District Sales Manager for more information.

Goto [www.multiquip.com](http://www.multiquip.com) and click on **Order Parts** to log in and save!

Use the **internet** and qualify for a **5% Discount** on *Standard orders* for all orders which include complete part numbers.\*

Note: Discounts Are Subject To Change



### Order via Fax (Dealers Only):

All customers are welcome to order parts via Fax.

**Domestic (US) Customers dial:**  
1-800-6-PARTS-7 (800-672-7877)

**Fax** your order in and qualify for a **2% Discount** on *Standard orders* for all orders which include complete part numbers.\*

Note: Discounts Are Subject To Change



**Order via Phone: Domestic (US) Dealers Call:**  
1-800-427-1244

### Non-Dealer Customers:

Contact your local Multiquip Dealer for parts or call 800-427-1244 for help in locating a dealer near you.



**International Customers** should contact their local Multiquip Representatives for Parts Ordering information.

## When ordering parts, please supply:

- |                                                                               |                                                                                        |
|-------------------------------------------------------------------------------|----------------------------------------------------------------------------------------|
| <input type="checkbox"/> Dealer Account Number                                | <input type="checkbox"/> Specify Preferred Method of Shipment:                         |
| <input type="checkbox"/> Dealer Name and Address                              | <input checked="" type="checkbox"/> UPS/Fed Ex <input checked="" type="checkbox"/> DHL |
| <input type="checkbox"/> Shipping Address (if different than billing address) | <input type="checkbox"/> Priority One <input checked="" type="checkbox"/> Truck        |
| <input type="checkbox"/> Return Fax Number                                    | <input type="checkbox"/> Ground                                                        |
| <input type="checkbox"/> Applicable Model Number                              | <input type="checkbox"/> Next Day                                                      |
| <input type="checkbox"/> Quantity, Part Number and Description of Each Part   | <input type="checkbox"/> Second/Third Day                                              |

### NOTICE

All orders are treated as *Standard Orders* and will ship the same day if received prior to 3PM PST.

WE ACCEPT ALL MAJOR CREDIT CARDS!



www.multiquip.com



# QP-301TY/QP-301TA — EXPLANATION OF CODE IN REMARKS COLUMN

The following section explains the different symbols and remarks used in the Parts section of this manual. Use the help numbers found on the back page of the manual if there are any questions.

## NOTICE

The contents and part numbers listed in the parts section are subject to change **without notice**. Multiquip does not guarantee the availability of the parts listed.

## SAMPLE PARTS LIST

NO.	PART NO.	PART NAME	QTY.	REMARKS
1	12345	BOLT.....	1	INCLUDES ITEMS W/%
2%		WASHER, 1/4 IN.....		NOT SOLD SEPARATELY
2%	12347	WASHER, 3/8 IN....	1	MQ-45T ONLY
3	12348	HOSE .....		A/R ...MAKE LOCALLY
4	12349	BEARING .....	1	S/N 2345B AND ABOVE

## NO. Column

**Unique Symbols** — All items with same unique symbol

(@, #, +, %, or >) in the number column belong to the same assembly or kit, which is indicated by a note in the “Remarks” column.

**Duplicate Item Numbers** — Duplicate numbers indicate multiple part numbers, which are in effect for the same general item, such as different size saw blade guards in use or a part that has been updated on newer versions of the same machine.

## NOTICE

When ordering a part that has more than one item number listed, check the remarks column for help in determining the proper part to order.

## PART NO. Column

**Numbers Used** — Part numbers can be indicated by a number, a blank entry, or TBD.

TBD (To Be Determined) is generally used to show a part that has not been assigned a formal part number at the time of publication.

A blank entry generally indicates that the item is not sold separately or is not sold by Multiquip. Other entries will be clarified in the “Remarks” Column.

## QTY. Column

**Numbers Used** — Item quantity can be indicated by a number, a blank entry, or A/R.

A/R (As Required) is generally used for hoses or other parts that are sold in bulk and cut to length.

A blank entry generally indicates that the item is not sold separately. Other entries will be clarified in the “Remarks” Column.

## REMARKS Column

Some of the most common notes found in the “Remarks” Column are listed below. Other additional notes needed to describe the item can also be shown.

**Assembly/Kit** — All items on the parts list with the same unique symbol will be included when this item is purchased.

Indicated by:

“INCLUDES ITEMS W/(unique symbol)”

**Serial Number Break** — Used to list an effective serial number range where a particular part is used.

Indicated by:

“S/N XXXXX AND BELOW”

“S/N XXXX AND ABOVE”

“S/N XXXX TO S/N XXX”

**Specific Model Number Use** — Indicates that the part is used only with the specific model number or model number variant listed. It can also be used to show a part is NOT used on a specific model or model number variant.

Indicated by:

“XXXXX ONLY”

“NOT USED ON XXXX”

**“Make/Obtain Locally”** — Indicates that the part can be purchased at any hardware shop or made out of available items. Examples include battery cables, shims, and certain washers and nuts.

**“Not Sold Separately”** — Indicates that an item cannot be purchased as a separate item and is either part of an assembly/kit that can be purchased, or is not available for sale through Multiquip.

# QP-301TY/QP-301TA — SUGGESTED SPARE PARTS

## QP-301TY/QP-301TA, TRASH PUMPS WITH YANMAR L60AEDP/ROBIN EH25 GASOLINE ENGINES

1 to 3 units

<u>QTY.</u>	<u>P/N</u>	<u>DESCRIPTION</u>
1 .....	1343040030 .....	IMPELLER
1 .....	0631211100 .....	FLOODING CAP
1 .....	0806123530 .....	MECHANICAL SEAL
1 .....	0811883056 .....	MECHANICAL SEAL SLEEVE
1 .....	0489352400 .....	O-RING DRAIN COVER
1 .....	0489353970 .....	O-RING CASING (QP-301TY)
1 .....	0489354020 .....	O-RING CASING (QP-301TA)
1 .....	0481310250 .....	O-RING MECHANICAL SEAL SLEEVE
1 .....	0852834525 .....	ADJUST LINER DIA. 45 X DIA. 25 T0.3
1 .....	0852854525 .....	ADJUST LINER DIA. 45 X DIA. 25 T0.5

### NOTICE

Part number on this Suggested Spare Parts List may supercede/replace the P/N shown in the text pages of this book.

# QP-301TY/QP-301TA — PUMP ASSY.

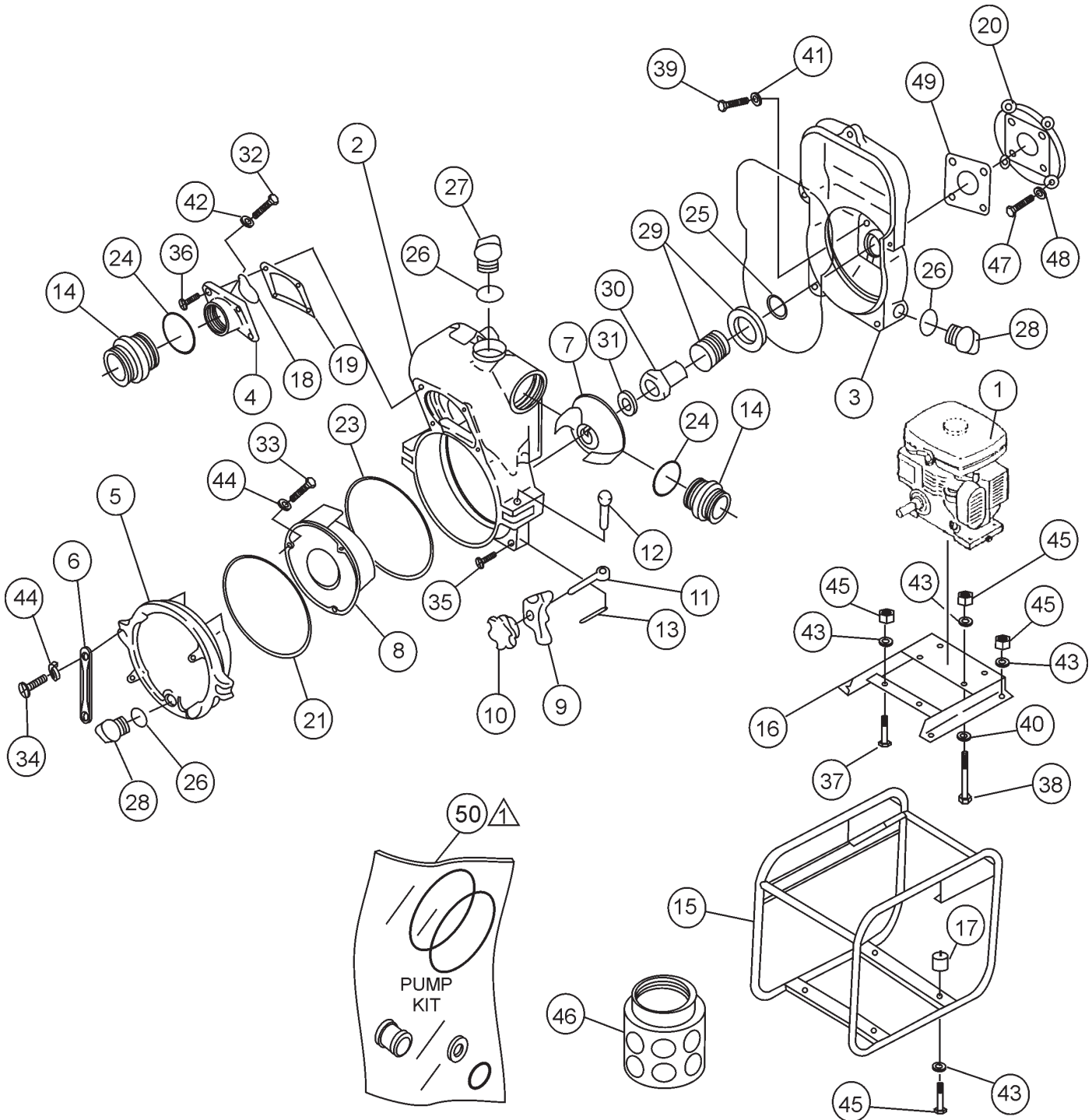

**NOTES:**

PUMP KIT INCLUDES ITEMS 20, 21, 23, 25, 29 AND 31.



# QP-301TY/QP-301TA — PUMP ASSY.

<u>NO.</u>	<u>PART NO.</u>	<u>PART NAME</u>	<u>QTY.</u>	<u>REMARKS</u>
1	L60AEDP	ENGINE, YANMAR L60 .....	1 .....	QP301TY
1	EH252YD1112	ENGINE, ROBIN EH25 .....	1 .....	QP301TA
2	1343100010	CASING NPS3"	1	
3	1317100020	CASING COVER	1	
4	1343100160	SUCTION COVER NPS3"	1	
5	1268100170	DRAIN COVER	1	
6	1247100250	DRAIN COVER HANDLE	2	
7	1343040030	IMPELLER	1	
8	1317000130	VOLUTE CASING	1	
9	1247000200	DRAIN COVER PUSH PLATE	2	
10	1247000190	DRAIN COVER SET HANDLE DIA.75 M12	2	
11	1247200270	HINGE BOLT M12 X 90	2	
12	1247220280	HINGE PIN	2	
13	0641400430	SPLIT PIN DIA. 4 X 30 .....	2 .....	QP301TY
13	0641400520	SPLIT PIN DIA. 4 X 30 .....	2 .....	QP301TA
14	0790433030	NIPPLE NPS3" X NPT 3"	2	
15	2345214010	PIPE FRAME	1	
16	2345214020	ENGINE BASE	1	
17	0723302040	CUSHION RUBBER DIA. 40 H20 M10	4	
18	1317350350	CHECK VALVE	1	
19	1317330370	SUCTION COVER PACKING	1	
20%	4313000600	CASING COVER SET PLATE G65 .....	1 .....	QP301TY
20%	1317390610	CASING COVER SET PLATE .....	1 .....	QP301TA
21%	0489352400	O-RING (DRAIN COVER) DIA. 3.5 X DIA. 240	1	
22	0489353970	O-RING (CASING) DIA. 3.5 X DIA. 397 .....	1 .....	QP301TY
22	0489354020	O-RING (CASING)DIA. 3.5 X DIA. 396 .....	1 .....	QP301TA
23%	0489312300	O-RING (VOLUTE CASING) DIA. 3.1 X DIA. 228	1	
24	0481310800	O-RING (NIPPLE) G80	2	
25%	0481310250	O-RING (MECHANICAL SEAL SLEEVE) G25	1	
26	0480350300	O-RING (FLOODING DRAIN CAP) P30	3	
27	0631211100	FLOODING CAP PF1"	1	
28	0631211100	DRAIN CAP PF1"	2	
29%	0801123530	MECHANICAL SEAL DIA. 30	1 SET	
30	0811883056	MECHANICAL SEAL SLEEVE DIA. 25.4 X DIA 30 X 56	1	
31%	0852834525	ADJUST LINER DIA. 45 X DIA. 25 t0.3	1	
31%	0852854525	ADJUST LINER DIA. 45 X DIA. 25 t0.5	1	
32	0141090510	SCREW (CHECK VALVE) M5 X 10	2	
33	0141090820	SCREW (VOLUTE CASING) M8 X 20	2	
34	0141050825	SCREW (DRAIN COVER HANDLE) M8 X 25	4	
35	0131151235	CAP SCREW (CASING) M12 X 35 .....	5 .....	QP301TY
35	014212030	CAP SCREW (CASING) M12 X 30 .....	5 .....	QP301TA

# QP-301TY/QP-301TA — PUMP ASSY.

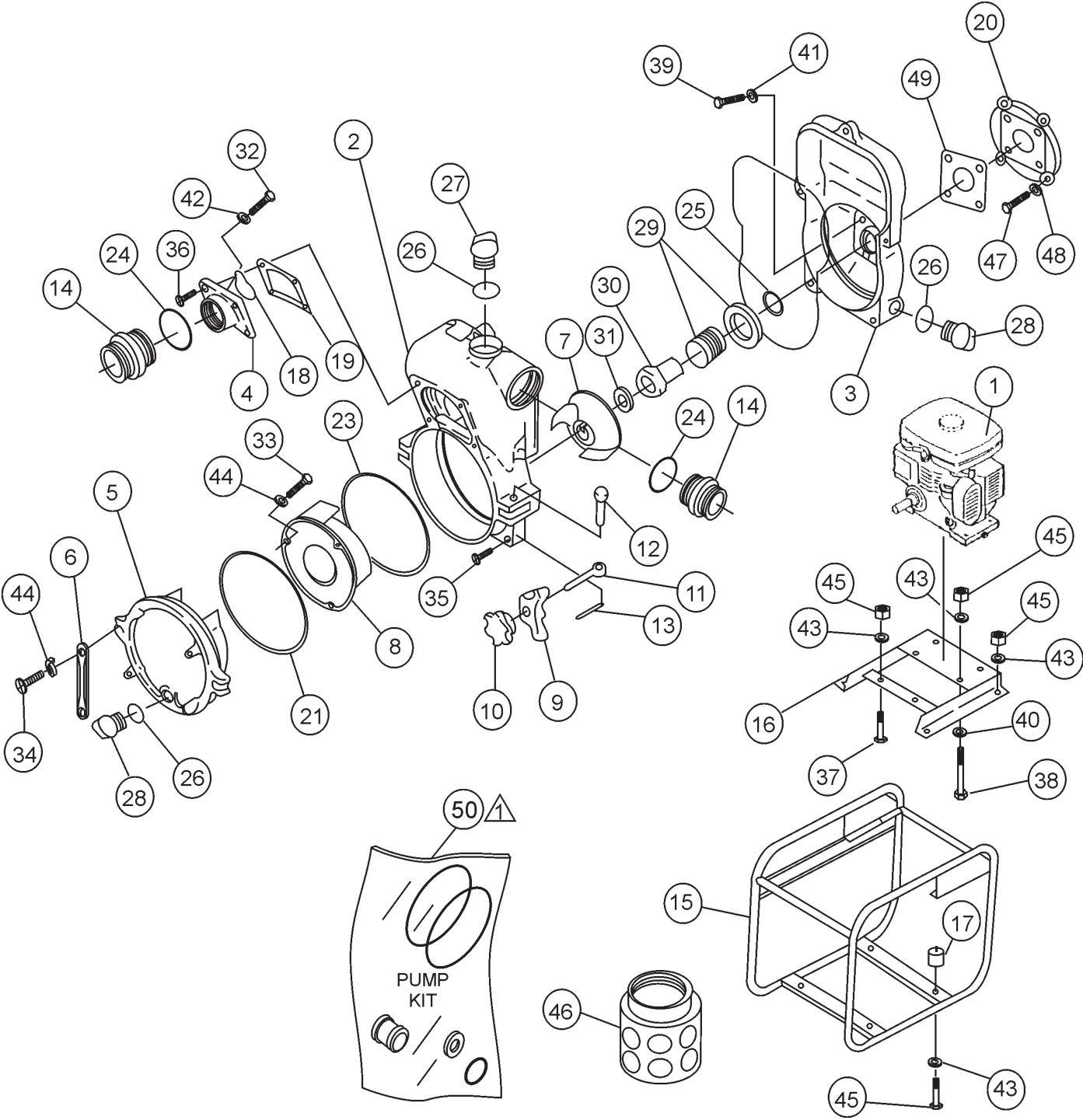

**NOTES:**

PUMP KIT INCLUDES ITEMS 20, 21, 23, 25, 29 AND 31.

## QP-301TY/QP-301TA — PUMP ASSY.

<u>NO.</u>	<u>PART NO.</u>	<u>PART NAME</u>	<u>QTY.</u>	<u>REMARKS</u>
36	0131151030	CAP SCREW (SUCTION COVER) M10 X 30	4	
37	0105051030	BOLT (PUMP) M10 X 30	2	
38	0105051045	BOLT (ENGINE) M10 X 45	4	
39	0106050820	BOLT (CASING COVER) M8 X 20-8T .....	4 .....	QP301TY
39	011708025	BOLT (CASING COVER) 8 X 25 .....	4 .....	QP301TA
40	0401450100	WASHER M10 .....	4 .....	QP301TY
40	031110160	WASHER, FLAT .....	4 .....	QP301TA
41	0458220080	SEAL WASHER M8 .....	4 .....	QP301TY
41	030208200	WASHER, LOCK 8 MM .....	4 .....	QP301TA
42	0401450050	WASHER M5	2	
43	0451250100	WASHER, LOCK M10 .....	14 .....	QP301TY
43	030210250	WASHER, LOCK M10 .....	14 .....	QP301TA
44	0451250080	WASHER, LOCK M8	6	
44	030208200	WASHER, LOCK 8 MM	6	
45	0205450100	NUT (PUMP ENG CUSHION RUBBER) M10 ....	14 .....	QP301TY
45	020310080	NUT (PUMP ENG CUSHION RUBBER) M10 ....	14 .....	QP301TA
46	0742304080	STRAINER NPT3" TRASH	1	
47	0181050825	BOLT M8 X 25	4	
48	0401450080	WASHER M8 .....	4 .....	QP301TY
48	0451250100	WASHER M8 .....	4 .....	QP301TA
49	1317390610	CASING COVER PACKING .....	1 .....	QP301TY
49	43130006000014	CASING COVER PACKING .....	1 .....	QP301TA
50	KIT301T	PUMP KIT .....	1 .....	INCLUDES ITEMS W/%

# TERMS AND CONDITIONS OF SALE — PARTS

## PAYMENT TERMS

Terms of payment for parts are net 30 days.

## FREIGHT POLICY

All parts orders will be shipped collect or prepaid with the charges added to the invoice. All shipments are F.O.B. point of origin. Multiquip's responsibility ceases when a signed manifest has been obtained from the carrier, and any claim for shortage or damage must be settled between the consignee and the carrier.

## MINIMUM ORDER

The minimum charge for orders from Multiquip is \$15.00 net. Customers will be asked for instructions regarding handling of orders not meeting this requirement.

## RETURNED GOODS POLICY

Return shipments will be accepted and credit will be allowed, subject to the following provisions:

1. A Returned Material Authorization must be approved by Multiquip prior to shipment.
2. To obtain a Return Material Authorization, a list must be provided to Multiquip Parts Sales that defines item numbers, quantities, and descriptions of the items to be returned.
  - a. The parts numbers and descriptions must match the current parts price list.
  - b. The list must be typed or computer generated.
  - c. The list must state the reason(s) for the return.
  - d. The list must reference the sales order(s) or invoice(s) under which the items were originally purchased.
  - e. The list must include the name and phone number of the person requesting the RMA.
3. A copy of the Return Material Authorization must accompany the return shipment.
4. Freight is at the sender's expense. All parts must be returned freight prepaid to Multiquip's designated receiving point.

5. Parts must be in new and resalable condition, in the original Multiquip package (if any), and with Multiquip part numbers clearly marked.
6. The following items are not returnable:
  - a. Obsolete parts. (If an item is in the price book and shows as being replaced by another item, it is obsolete.)
  - b. Any parts with a limited shelf life (such as gaskets, seals, "O" rings, and other rubber parts) that were purchased more than six months prior to the return date.
  - c. Any line item with an extended dealer net price of less than \$5.00.
  - d. Special order items.
  - e. Electrical components.
  - f. Paint, chemicals, and lubricants.
  - g. Decals and paper products.
  - h. Items purchased in kits.
7. The sender will be notified of any material received that is not acceptable.
8. Such material will be held for five working days from notification, pending instructions. If a reply is not received within five days, the material will be returned to the sender at his expense.
9. Credit on returned parts will be issued at dealer net price at time of the original purchase, less a 15% restocking charge.
10. In cases where an item is accepted, for which the original purchase document can not be determined, the price will be based on the list price that was effective twelve months prior to the RMA date.
11. Credit issued will be applied to future purchases only.

## PRICING AND REBATES

Prices are subject to change without prior notice. Price changes are effective on a specific date and all orders received on or after that date will be billed at the revised price. Rebates for price declines and added charges for price increases will not be made for stock on hand at the time of any price change.

Multiquip reserves the right to quote and sell direct to Government agencies, and to Original Equipment Manufacturer accounts who use our products as integral parts of their own products.

## SPECIAL EXPEDITING SERVICE

A \$35.00 surcharge will be added to the invoice for special handling including bus shipments, insured parcel post or in cases where Multiquip must personally deliver the parts to the carrier.

## LIMITATIONS OF SELLER'S LIABILITY

Multiquip shall not be liable hereunder for damages in excess of the purchase price of the item with respect to which damages are claimed, and in no event shall Multiquip be liable for loss of profit or good will or for any other special, consequential or incidental damages.

## LIMITATION OF WARRANTIES

No warranties, express or implied, are made in connection with the sale of parts or trade accessories nor as to any engine not manufactured by Multiquip. Such warranties made in connection with the sale of new, complete units are made exclusively by a statement of warranty packaged with such units, and Multiquip neither assumes nor authorizes any person to assume for it any other obligation or liability whatever in connection with the sale of its products. Apart from such written statement of warranty, there are no warranties, express, implied or statutory, which extend beyond the description of the products on the face hereof.

Effective: February 22, 2006



# PARTS MANUAL

## HERE'S HOW TO GET HELP

PLEASE HAVE THE MODEL AND SERIAL  
NUMBER ON-HAND WHEN CALLING

### **UNITED STATES**

#### ***Multiquip Corporate Office***

18910 Wilmington Ave.  
Carson, CA 90746  
Contact: mq@multiquip.com

Tel. (800) 421-1244  
Fax (800) 537-3927

#### ***MQ Parts Department***

800-427-1244 Fax: 800-672-7877  
310-537-3700 Fax: 310-637-3284

#### ***Mayco Parts***

800-306-2926  
310-537-3700

Fax: 800-672-7877  
Fax: 310-637-3284

#### ***Warranty Department***

800-421-1244, Ext. 279 Fax: 310-537-1173  
310-537-3700, Ext. 279

#### ***Service Department***

800-421-1244  
310-537-3700

Fax: 310-537-4259

#### ***Technical Assistance***

800-478-1244 Fax: 310-631-5032

### **MEXICO**

#### ***MQ Cipsa***

Carr. Fed. Mexico-Puebla KM 126.5  
Momoxpan, Cholula, Puebla 72760 Mexico  
Contact: pmastretta@cipsa.com.mx

Tel: (52) 222-225-9900  
Fax: (52) 222-285-0420

### **UNITED KINGDOM**

#### ***Multiquip (UK) Limited Head Office***

Unit 2, Northpoint Industrial Estate,  
Global Lane,  
Dukinfield, Cheshire SK16 4UJ  
Contact: sales@multiquip.co.uk

Tel: 0161 339 2223  
Fax: 0161 339 3226

### **CANADA**

#### ***Multiquip***

4110 Industriel Boul.  
Laval, Quebec, Canada H7L 6V3  
Contact: jmartin@multiquip.com

Tel: (450) 625-2244  
Tel: (877) 963-4411  
Fax: (450) 625-8664

© COPYRIGHT 2010, MULTIQUIP INC.

Multiquip Inc and the MQ logo are registered trademarks of Multiquip Inc. and may not be used, reproduced, or altered without written permission. All other trademarks are the property of their respective owners and used with permission.

This manual MUST accompany the equipment at all times. This manual is considered a permanent part of the equipment and should remain with the unit if resold.

The information and specifications included in this publication were in effect at the time of approval for printing. Illustrations, descriptions, references and technical data contained in this manual are for guidance only and may not be considered as binding. Multiquip Inc. reserves the right to discontinue or change specifications, design or the information published in this publication at any time without notice and without incurring any obligations.

Your Local Dealer is:

