

The application and detail drawings in this manual are strictly for illustration purposes and may not be applicable to all building designs or product installations. All projects should conform to applicable building codes for that particular area. It is recommended to follow all building regulations and standard industry practices.

Metal Sales Manufacturing Corporation is not responsible for the performance of the roof system if it is not installed in accordance with the suggested instructions referenced in this installation manual or in the product overview. (See Product Manual or Product Technical Literature). If there is a conflict between this manual and the actual erection drawings, the erection drawings are to take precedence.

Prior to ordering and installing materials, all dimensions should be verified by field measurements.

Metal Sales reserves the right to modify, without notice, any details, recommendations or suggestions. Any questions you may have regarding proper installation of the roofing system should be directed to your Metal Sales representative, see pages 2 and 3.

Consult Metal Sales for any additional information not outlined in this manual.

This manual is designed to be utilized as a guide when installing Post Frame and Residential roofing systems.

It is the responsibility of the erector to ensure the safe installation of this product system.

## **SAFETY**

### **STUDY APPLICABLE OSHA AND OTHER SAFETY REQUIREMENTS BEFORE FOLLOWING THESE INSTRUCTIONS.**

The installation of metal roof systems is a dangerous procedure and should be supervised by trained knowledgeable erectors. **USE EXTREME CARE WHILE INSTALLING ROOF PANELS.** It is not possible for Metal Sales to be aware of all the possible job site situations that could cause an unsafe condition to exist. The erector of the roof system is responsible for reading these instructions and determining the safest way to install the roof system.

These instructions are provided only as a guide to show a knowledgeable, trained erector the correct part placement one to another. If following any of the installation steps would endanger a worker, the erector should stop work and decide upon a corrective action.

Provide required safety railing, netting, or safety lines for crew members working on the roof.

Do not use the roof panel as a walking platform. The roof panels will not withstand the weight of a person standing at the edge of the panel.

Do not stand on the roof panel until the panels have been attached.

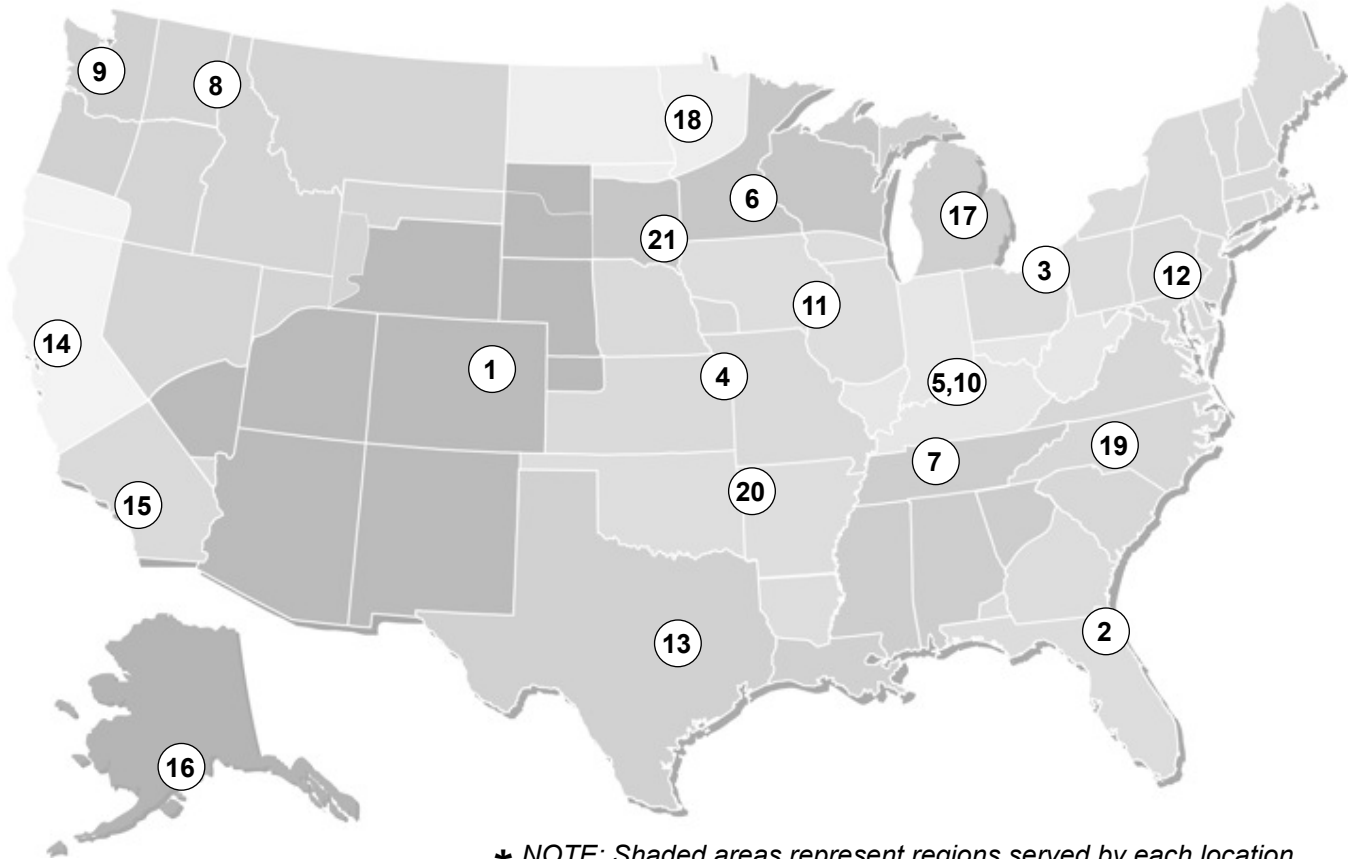

\* NOTE: Shaded areas represent regions served by each location.

For more than 55 years, Metal Sales Manufacturing Corporation has earned a reputation as the premier provider of innovative metal building components and accessories.

We've backed this reputation with the industry's largest professional sales and services team. We offer a full line of exceptional quality metal roof and wall panels for agricultural, commercial, architectural, industrial and residential projects of every shape and size, new construction or retro-fit.

**1. DENVER BRANCH**

7990 E. I-25 Frontage Road  
 Longmont, CO 80504  
 303.702.5440  
 800.289.7663  
 800.289.1617 Fax

**2. JACKSONVILLE BRANCH**

7110 Stuart Avenue  
 Jacksonville, FL 32254  
 904.783.3660  
 800.394.4419  
 904.783.9175 Fax  
 800.413.3292 Fax

**3. JEFFERSON BRANCH**

352 East Erie Street  
 Jefferson, OH 44047  
 440.576.9070  
 800.321.5833  
 440.576.9242 Fax  
 800.233.5719 Fax

**4. INDEPENDENCE BRANCH**

1306 South Powell Road  
 Independence, MO 64057  
 816.796.0900  
 800.747.0012  
 816.796.0906 Fax

**5. SELLERSBURG BRANCH**

7800 State Road 60  
 Sellersburg, IN 47172  
 812.246.1866  
 800.999.7777  
 812.246.0893 Fax  
 800.477.9318 Fax

**6. ROGERS BRANCH**

22651 Industrial Boulevard  
 Rogers, MN 55374  
 763.428.8080  
 800.328.9316  
 763.428.8525 Fax  
 800.938.9119 Fax

**7. NASHVILLE BRANCH**

4314 Hurricane Creek Boulevard  
 Antioch, TN 37013  
 615.641.7100  
 800.251.8508  
 615.641.7118 Fax  
 800.419.4372 Fax

**8. SPOKANE BRANCH**

East 2727 Trent Avenue  
 Spokane, WA 99202  
 509.536.6000  
 800.572.6565  
 509.534.4427 Fax

**9. SEATTLE BRANCH**

20213 84th Avenue, South  
 Kent, WA 98032  
 253.872.5750  
 800.431.3470 (Outside WA)  
 800.742.7900 (Inside WA)  
 253.872.2008 Fax

**10. NEW ALBANY BRANCH**

999 Park Place  
 New Albany, IN 47150  
 812.944.2733  
 812.944.1418 Fax

**11. ROCK ISLAND BRANCH**

8111 West 29th Street  
 Rock Island, IL 61201  
 309.787.1200  
 800.747.1206  
 309.787.1833 Fax

**12. DEER LAKE BRANCH**

29 Pinedale Industrial Road  
 Orwigsburg, PA 17961  
 570.366.2020  
 800.544.2577  
 570.366.1648 Fax  
 800.544.2574 Fax

**13. TEMPLE BRANCH**

3838 North General Bruce Drive  
 Temple, TX 76501  
 254.791.6650  
 800.543.4415  
 254.791.6655 Fax  
 800.543.4473 Fax

**14. WOODLAND BRANCH**

1326 Paddock Place  
 Woodland, CA 95776  
 530.668.5690  
 800.759.6019  
 530.668.0901 Fax

**15. FONTANA BRANCH**

14213 Whittram Avenue  
 Fontana, CA 92335  
 909.829.8618  
 800.782.7953  
 909.829.9083 Fax

**16. ANCHORAGE BRANCH**

4637 Old Seward Highway  
 Anchorage, AK 99503  
 907.646.7663  
 866.640.7663  
 907.646.7664 Fax

**17. BAY CITY BRANCH**

5209 Mackinaw Road  
 Bay City, MI 48706  
 989.686.5879  
 888.777.7640  
 989.686.5870 Fax  
 888.777.0112 Fax

**18. DETROIT LAKES BRANCH**

1435 Egret Avenue  
 Detroit Lakes, MN 56501  
 218.847.2988  
 888.594.1394  
 218.847.4835 Fax  
 888.594.1454 Fax

**19. MOCKSVILLE BRANCH**

188 Quality Drive  
 Mocksville, NC 27028  
 336.751.6381  
 800.228.6119  
 336.751.6301 Fax  
 800.228.7916 Fax

**20. FORT SMITH BRANCH**

7510 Ball Road  
 Fort Smith, AR 72908  
 479.646.1176  
 877.452.3915  
 479.646.5204 Fax

**21. SIOUX FALLS BRANCH**

2700 West 3rd Street, Suite 4  
 Sioux Falls, SD 57104  
 605.335.2745  
 888.299.0024

**TECHNICAL SUPPORT**

**TECHNICAL SERVICES**

545 South 3rd Street, Suite 200  
 Louisville, KY 40202  
 502.855.4300  
 800.406.7387  
 502.855.4290 Fax  
 800.944.6884 Fax

<b>General Information</b>	<b>PAGE NO.</b>
Important Information .....	1
Metal Sales' Locations .....	2
Customer Service .....	3
<b>Panel Information</b>	
Classic Rib® .....	6,7
Pro-Panel II® .....	8,9
Delta Rib .....	10,11
5V-Crimp .....	12,13
2.5" Corrugated Roof .....	14,15
2.5" Corrugated Wall.....	16,17
1.25" Corrugated .....	18,19
<b>Fastener Installation.....</b>	<b>20</b>
<b>Post Frame Flashing Profiles .....</b>	<b>21-23</b>
<b>Residential Flashing Profiles .....</b>	<b>24</b>
<b>Accessory Profiles .....</b>	<b>25</b>
<b>Handling Material</b>	
Receiving Material .....	26
General Handling .....	26
Mechanical Handling .....	26
Manual Handling .....	27
<b>Storage</b>	
General .....	28
Foot Traffic .....	28
Required Tools.....	28
<b>Design / Installation Considerations</b>	
General.....	29
Condition of Substructure .....	29
<b>Field Cutting and Touch-Up</b>	
Field Cutting.....	30
Touch-Up Paint .....	30
Ventilation .....	30
<b>Fastener Selection Guide .....</b>	<b>31</b>
<b>Installation Overview .....</b>	<b>32</b>
<b>Post Frame Panel Installation</b>	
Installing Inside Closures (Step 1).....	33
Installing First Panel (Step 2).....	33
Installing Endlap Panel (Step 3) .....	34
Installing Sidelap Panel (Step 4).....	34
14" Universal Ridge Detail.....	35
Low Profile Ridge Vent Detail .....	35
Outside Corner Detail .....	35
Inside Corner Detail .....	35
Gable Trim Detail .....	36
Rake Trim Detail .....	36
Universal Sidewall Detail .....	36
Universal Endwall Detail.....	36

	<b>PAGE NO.</b>
Eave Molding Detail.....	37
Universal Gambrel Detail.....	37
Angle Base Detail.....	37
Double Angle Detail.....	37
Drip Cap Detail.....	38
Base Molding Detail.....	38
Cannonball Track Cover Detail.....	38
National Track Cover Detail.....	38
Door Jamb Molding Detail.....	39
Mini-Angle - U-Flashing Detail.....	39
Post Trim Detail.....	39
Door Post Trim Detail.....	39
Overhead Door Trim Detail.....	40
Soffit Detail.....	40
12" Soffit Detail.....	40
24" Soffit Detail.....	40
<b>Installation Overview.....</b>	<b>41</b>
<b>Residential Panel Installation</b>	
Installing Inside Closures (Step 1).....	42
Installing First Panel (Step 2).....	42
Installing Second Panel (Step 3).....	43
Installing Second Eave Panel (Step 4).....	43
14" Universal Ridge Detail.....	44
Ridge / Hip Cover Detail.....	44
Vented Ridge Detail.....	44
Gable Trim Detail.....	44
Eave Detail.....	45
Gutter Detail.....	45
Valley Detail.....	45
Pitch Break Detail.....	45
Chimney / Cricket Detail.....	46
Roof Penetration Detail.....	46
<b>Care and Maintenance.....</b>	<b>47</b>

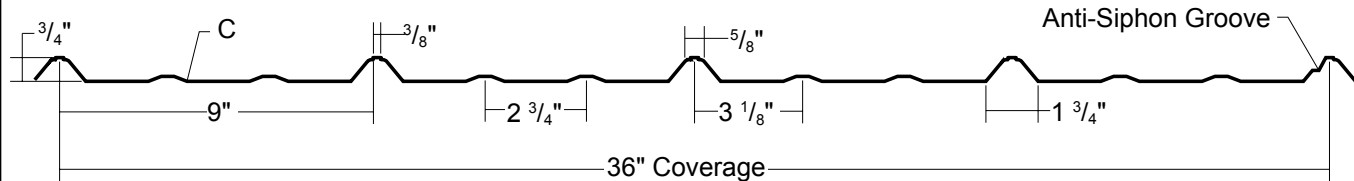

**PANEL OVERVIEW**

- ▶ **Finishes:** MS Colorfast45®, ColorFit40™, MS Crinkle Finish and Acrylic Coated Galvalume®
- ▶ **Corrosion Protection:** AZ55 per ASTM A 792 for unpainted Galvalume®  
AZ50 per ASTM A 792 for painted Galvalume®  
AZ35 per ASTM A 792 for painted Galvalume® (ColorFit40™ only)  
G60, G90 or G100 per ASTM A 653 for Galvanized
- ▶ **Gauges:** 29 ga and 26 ga standard; 24 ga optional
- ▶ **Panel Length:** Minimum: 5'-0"; Maximum: 45'-0" recommended
- ▶ **Profile:** 36" panel coverage, 3/4" rib height
- ▶ **Info:** Exposed fastened panel, low profile, bell-top trapezoidal rib on 9" centers
- ▶ **Minimum roof slope:** 3:12

**TESTING AND APPROVALS**

- ▶ UL 2218 Impact Resistance - Class 4
- ▶ UL 790 Fire Resistance Rating - Class A, per building code
- ▶ UL 263 Fire Resistance Rating - per assembly
- ▶ UL 580 Uplift Resistance - Class 90 Constructions: #560, 584
- ▶ ASTM E 455, Diaphragm Capacity
- ▶ Texas Wind Storm - Evaluation RC-161
- ▶ 2017 FBC Approvals - FL9482.2, FL9482.3, FL10999.3, FL10999.4, FL14645.5, FL14645.8, FL14645.9, FL14645.10 and FL14645.11
- ▶ Miami-Dade County, Florida NOA 16-0218.02, expires 8/24/2021
- ▶ ICC Evaluation Report, ESR-2385

**SECTION PROPERTIES**

SECTION PROPERTIES								ALLOWABLE UNIFORM LOADS, psf For various fastener spacings											
Ga	Width in	Yield ksi	Weight psf	Top in Compression		Bottom in Compression		Inward Load				Outward Load							
				Ixx in <sup>2</sup> /ft	Sxx in <sup>3</sup> /ft	Ixx in <sup>2</sup> /ft	Sxx in <sup>3</sup> /ft	1.5'	2'	2.5'	3'	3.5'	4'	1.5'	2'	2.5'	3'	3.5'	4'
29	36	80	0.63	0.0097	0.0162	0.0060	0.0140	171	97	62	43	32	24	197	112	72	50	37	25
26	36	80	0.80	0.0123	0.0207	0.0080	0.0181	221	125	81	56	41	32	251	143	92	64	47	32
24	36	50	1.05	0.0163	0.0268	0.0117	0.0241	245	139	90	62	46	35	271	154	99	69	51	39

1. Theoretical section properties have been calculated per AISI 2016 'North American Specification for the Design of Cold-Formed Steel Structural Members'. Ixx and Sxx are effective section properties for deflection and bending.
2. Allowable load is calculated in accordance with AISI 2016 specifications considering bending, shear, combined bending and shear and deflection. Allowable load considers the 3 or more equal spans condition. Allowable load does not address web crippling, fasteners, support material or load testing. Panel weight is not considered.
3. Deflection consideration is limited by a maximum deflection ratio of L/180 of span.
4. Allowable loads do not include a 1/3 stress increase for wind.
5. **Diaphragm Capacity** - 246 plf average Ultimate Shear Strength using the above fastening pattern on 2x supports located 2' on center, per ASTM E 455.

PANEL LAP DETAIL

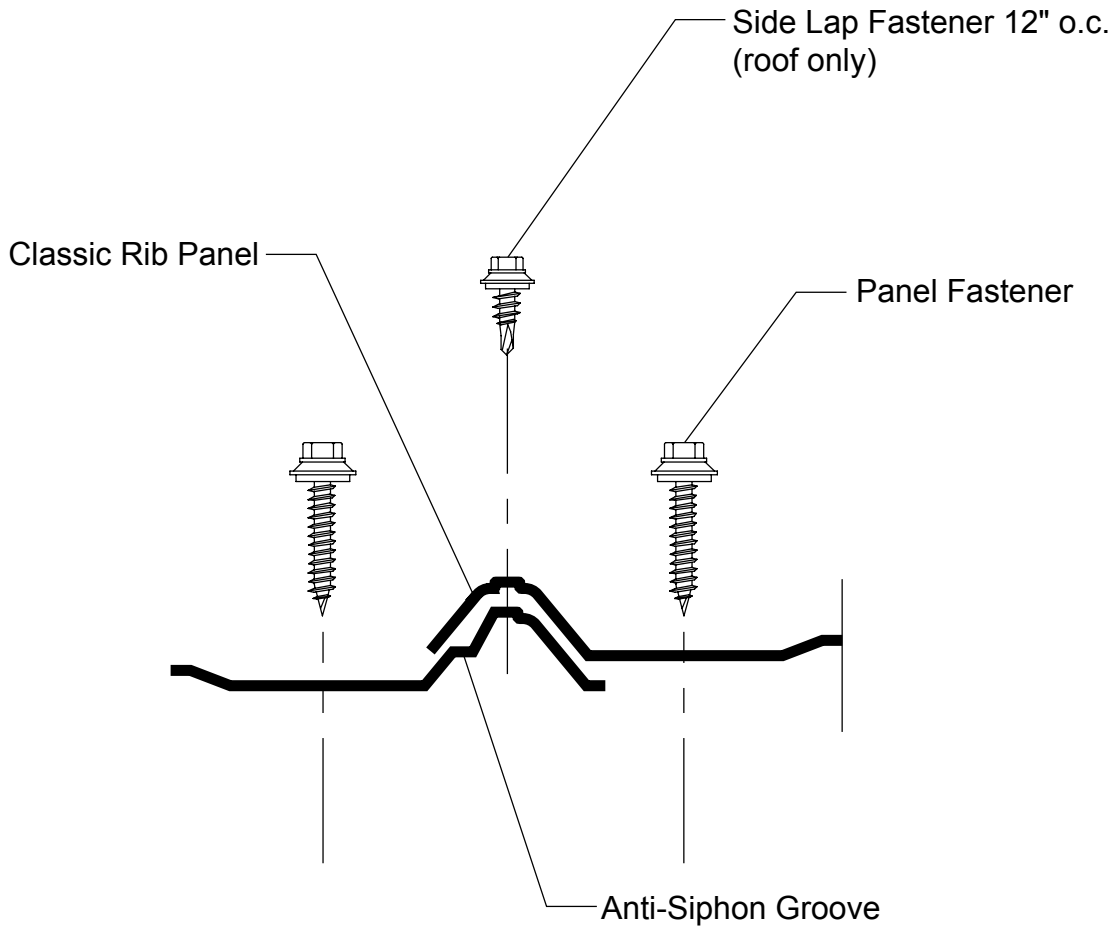

FASTENING PATTERNS

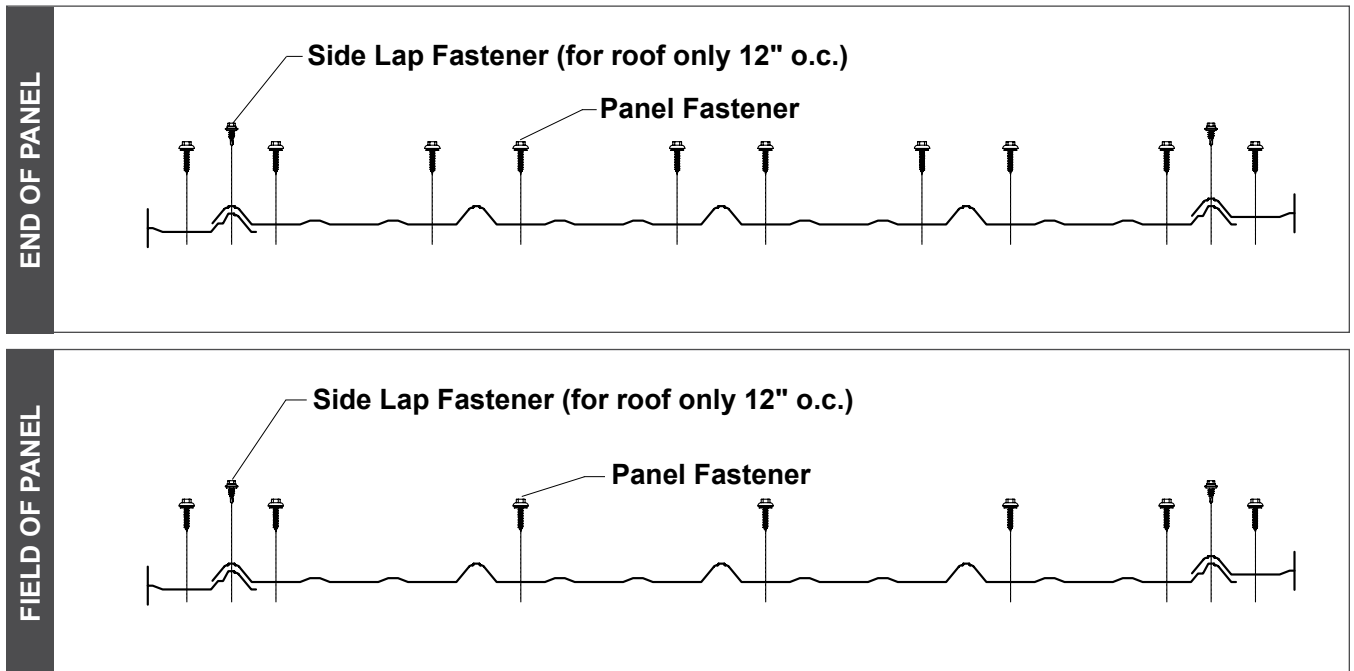

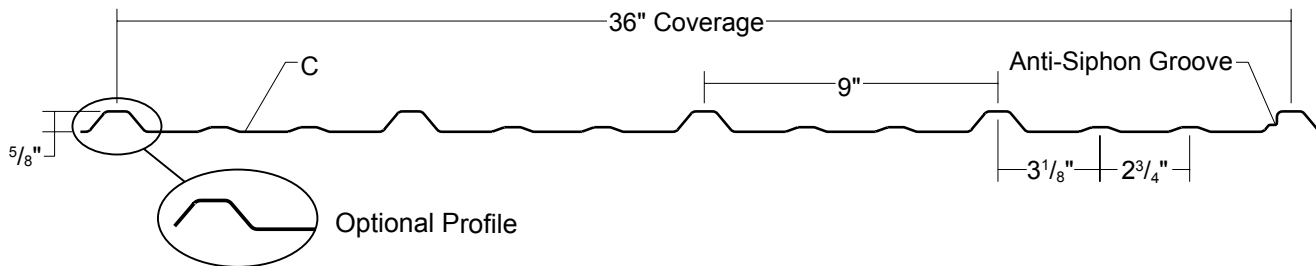

**PANEL OVERVIEW**

- ▶ **Finishes:** MS Colorfast45®, ColorFit40™, MS Crinkle Finish and Acrylic Coated Galvalume®
- ▶ **Corrosion Protection:** AZ55 per ASTM A 792 for unpainted Galvalume®  
AZ50 per ASTM A 792 for painted Galvalume®  
AZ35 per ASTM A 792 for painted Galvalume® (ColorFit40™ only)  
G60, G90 or G100 per ASTM A 653 for Galvanized
- ▶ **Gauges:** 29 ga and 26 ga standard
- ▶ **Panel Length:** Minimum: 5'; Maximum: 45' recommended
- ▶ **Profile:** 36" panel coverage, 5/8" rib height
- ▶ **Info:** Exposed fastened, low profile roof and wall panel; Trapezoidal rib on 9" centers
- ▶ **Minimum roof slope:** 3:12

**TESTING AND APPROVALS**

- ▶ UL 2218 Impact Resistance - Class 4
  - ▶ UL 790 Fire Resistance Rating - Class A, per building code
  - ▶ UL 263 Fire Resistance Rating - per assembly
  - ▶ ASTM E 283 Air Leakage - 0.0076 cfm/ft<sup>2</sup> at 6.24 psf \*
  - ▶ ASTM E 331 Water Penetration - none at 12 psf\*
  - ▶ ASTM E 330 Structural Performance
  - ▶ ASTM E 455 Diaphragm Capacity
  - ▶ 2017 FBC Approval - FL14645.14
- \*uses tape sealant and stitch screws 12" on center in side lap

**SECTION PROPERTIES**

SECTION PROPERTIES								ALLOWABLE UNIFORM LOADS, psf For various fastener spacings											
Ga	Width in	Yield ksi	Weight psf	Top In Compression		Bottom In Compression		Inward Load						Outward Load					
				I <sub>xx</sub> in <sup>4</sup> /ft	S <sub>xx</sub> in <sup>3</sup> /ft	I <sub>xx</sub> in <sup>4</sup> /ft	S <sub>xx</sub> in <sup>3</sup> /ft	1.5'	2'	2.5'	3'	3.5'	4'	1.5'	2'	2.5'	3'	3.5'	4'
29	36	80	0.62	0.0060	0.0123	0.0043	0.0128	155	88	57	40	27	18	150	85	55	38	27	18
26	36	80	0.79	0.0083	0.0171	0.0057	0.0165	200	114	73	51	34	23	207	118	76	53	34	23

1. Theoretical section properties have been calculated per AISI 2016 'North American Specification for the Design of Cold-Formed Steel Structural Members'. I<sub>xx</sub> and S<sub>xx</sub> are effective section properties for deflection and bending.
2. Allowable load is calculated in accordance with AISI 2016 specifications considering bending, shear, combined bending and shear and deflection. Allowable load considers the 3 or more equal spans condition. Allowable load does not address web crippling, fasteners, support material or load testing. Panel weight is not considered.
3. Deflection consideration is limited by a maximum deflection ratio of L/180 of span.
4. Allowable loads do not include a 1/3 stress increase for wind.
5. **Diaphragm Capacity** - 306 plf average Ultimate Shear Strength using the above fastening pattern on 2x supports located 2' on center, per ASTM E 455.



PANEL LAP DETAIL

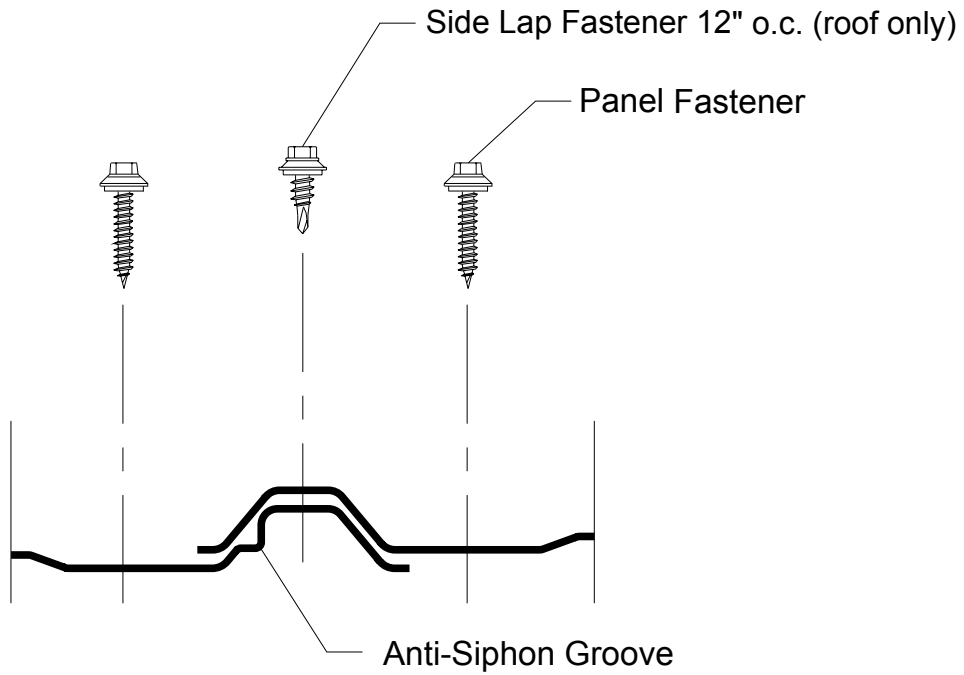

FASTENING PATTERNS

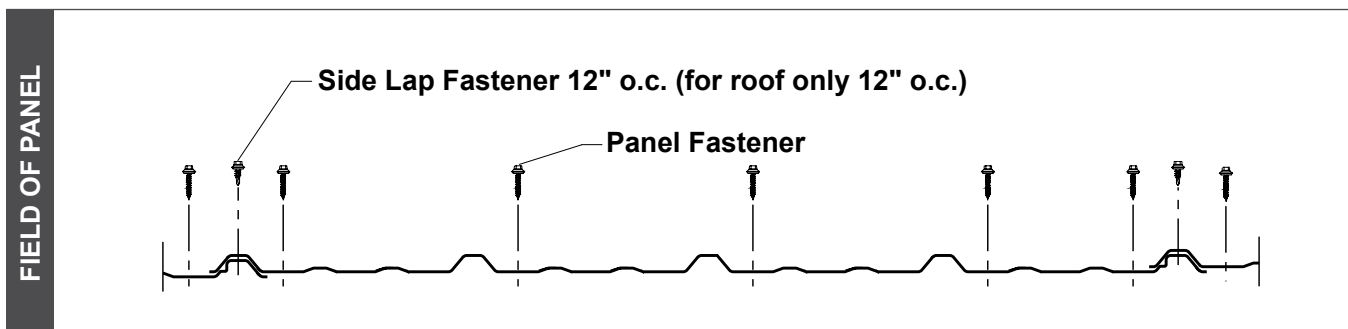
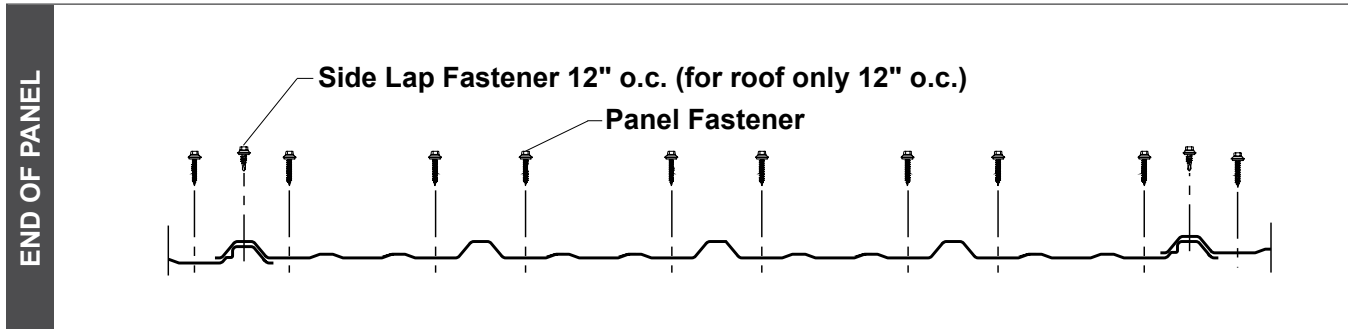

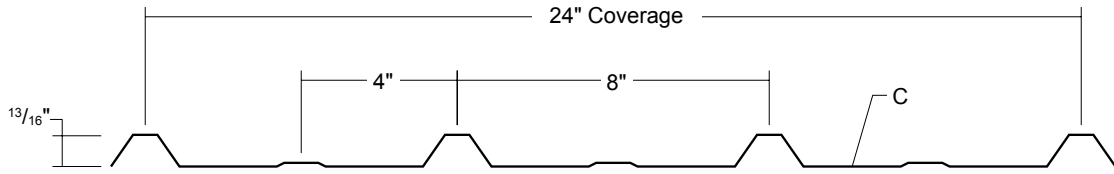

**PANEL OVERVIEW**

- ▶ **Finishes:** MS Colorfast45® and Acrylic Coated Galvalume®
- ▶ **Corrosion Protection:** AZ55 per ASTM A 792 for unpainted Galvalume®  
AZ50 per ASTM A 792 for painted Galvalume®  
G90 per ASTM A 653 for Galvanized
- ▶ **Gauges:** 29 ga and 26 ga standard, 24 ga optional
- ▶ **Panel Length:** Minimum: 5'; Maximum: 40' recommended
- ▶ **Profile:** 24" panel coverage, 13/16" rib height
- ▶ **Info:** Exposed fastened, low profile roof and wall panel; Trapezoidal rib on 8" centers
- ▶ **Minimum roof slope:** 3:12

**TESTING AND APPROVALS**

- ▶ UL 2218 Impact Resistance - Class 4
- ▶ UL 790 Fire Resistance Rating - Class A, per building code
- ▶ UL 263 Fire Resistance Rating - per assembly

**SECTION PROPERTIES**

SECTION PROPERTIES								ALLOWABLE UNIFORM LOADS, psf For various fastener spacings											
Ga	Width in	Yield ksi	Weight psf	Top In Compression		Bottom In Compression		Inward Load						Outward Load					
				I <sub>xx</sub> in <sup>4</sup> /ft	S <sub>xx</sub> in <sup>3</sup> /ft	I <sub>xx</sub> in <sup>4</sup> /ft	S <sub>xx</sub> in <sup>3</sup> /ft	3'	3.5'	4'	4.5'	5'	6'	3'	3.5'	4'	4.5'	5'	6'
29	24	80	0.64	0.0115	0.0193	0.0100	0.0228	67	50	37	29	19	11	58	43	33	26	19	11
26	24	80	0.82	0.0165	0.0283	0.0135	0.0295	89	66	48	34	25	14	86	64	48	34	25	14
24	24	50	1.07	0.0230	0.0403	0.0195	0.0394	101	74	57	44	32	19	103	76	58	44	32	19

1. Theoretical section properties have been calculated per AISI 2016 'North American Specification for the Design of Cold-Formed Steel Structural Members'. I<sub>xx</sub> and S<sub>xx</sub> are effective section properties for deflection and bending.
2. Allowable load is calculated in accordance with AISI 2016 specifications considering bending, shear, combined bending and shear and deflection. Allowable load considers the 3 or more equal spans condition. Allowable load does not address web crippling, fasteners, support material or load testing. Panel weight is not considered.
3. Deflection consideration is limited by a maximum deflection ratio of L/180 of span.
4. Allowable loads do not include a 1/3 stress increase for wind.

PANEL LAP DETAIL

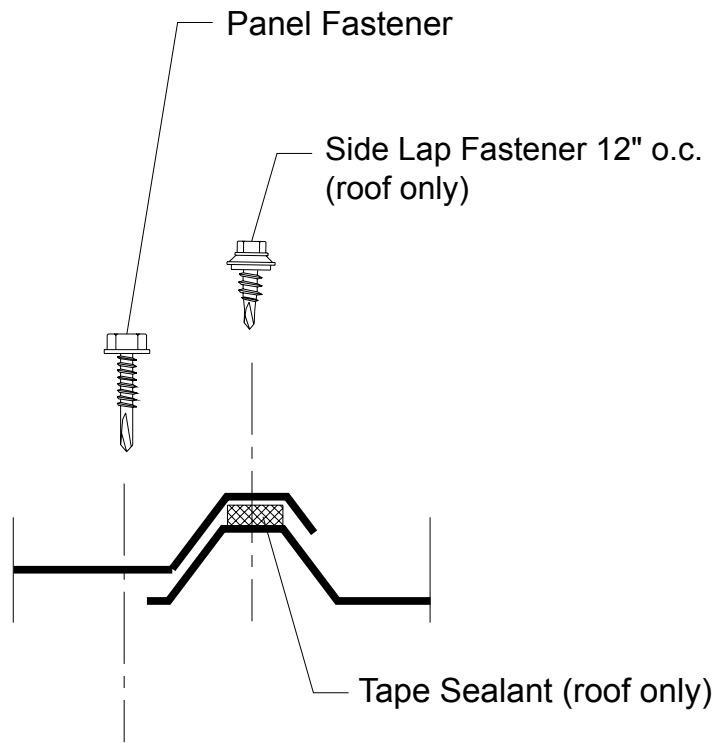

FASTENING PATTERN

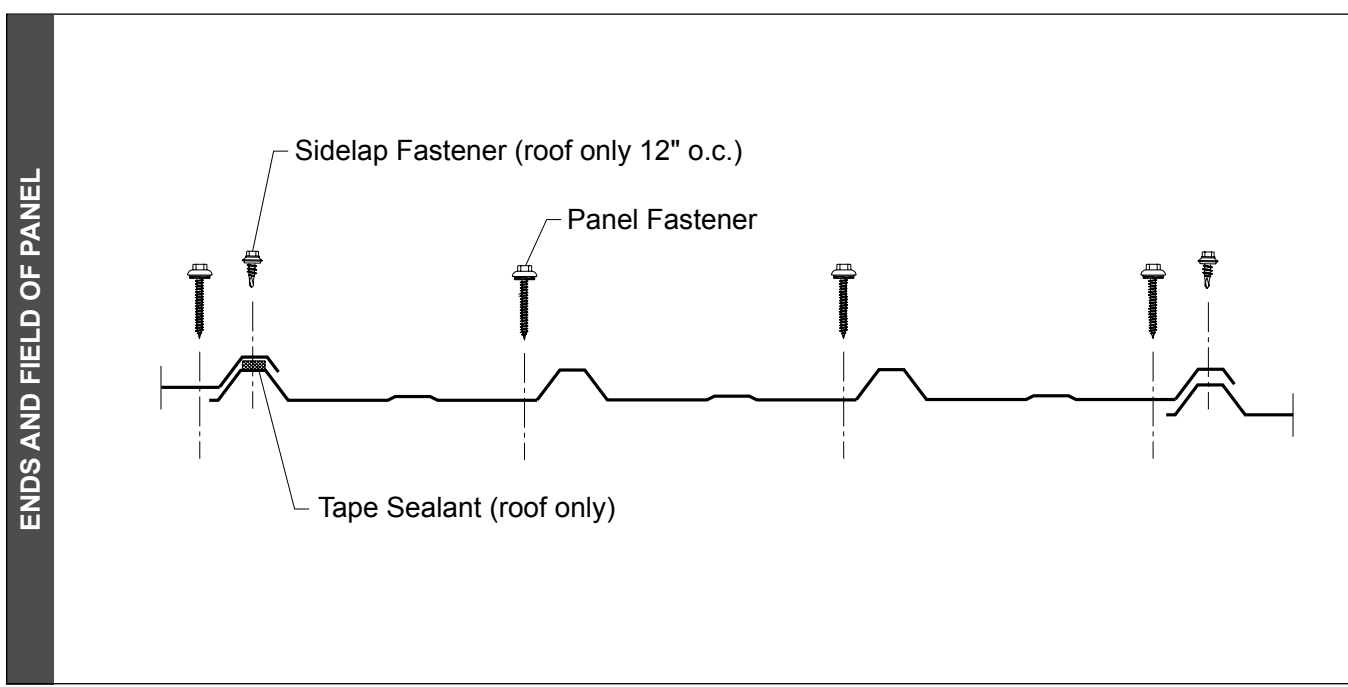

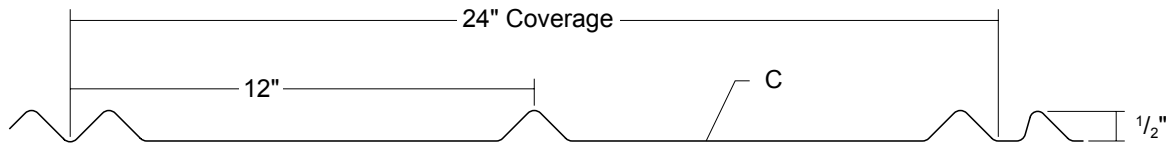

**PANEL OVERVIEW**

- ▶ **Finishes:** MS Colorfast45® and Acrylic Coated Galvalume®
- ▶ **Corrosion Protection:** AZ55 per ASTM A 792 for unpainted Galvalume®  
AZ50 per ASTM A 792 for painted Galvalume®  
G90 per ASTM A 653 for Galvanized
- ▶ **Gauges:** 26 ga standard; 24 ga optional
- ▶ **Panel Length:** Minimum: 5'; Maximum: 45' recommended
- ▶ **Profile:** 24" panel coverage, 1/2" rib height
- ▶ **Minimum roof slope:** 3:12
- ▶ **Info:** "V" rib roof panel 12" on center. Applies over plywood with minimum 30# felt underlayment

**TESTING AND APPROVALS**

- ▶ UL 2218 Impact Resistance - Class 4
- ▶ UL 790 Fire Resistance Rating - Class A, per building code
- ▶ UL 263 Fire Resistance Rating - per assembly
- ▶ UL 580 Uplift Resistance - Class 90 Constructions: #579 and #453
- ▶ Texas Windstorm - Evaluation RC-160
- ▶ 2017 FBC Approvals - FL14645.2, FL14645.3 and FL14645.4
- ▶ Miami-Dade County, Florida NOA 18-0313.02 expires 6/29/2023

**SECTION PROPERTIES**

SECTION PROPERTIES								ALLOWABLE UNIFORM LOADS, psf For various fastener spacings					
Ga	Width in	Yield ksi	Weight psf	Top In Compression		Bottom In Compression		Outward Load					
				Ixx in <sup>4</sup> /ft	Sxx in <sup>3</sup> /ft	Ixx in <sup>4</sup> /ft	Sxx in <sup>3</sup> /ft	0.5'	1'	1.5'	2'	2.5'	3'
26	24	50	0.78	0.0025	0.0070	0.0015	0.0055	197	100	71	62	50	42
24	24	50	1.02	0.0030	0.0089	0.0020	0.0073	197	100	71	62	50	42

1. Theoretical section properties have been calculated per AISI 2016 'North American Specification for the Design of Cold-Formed Steel Structural Members'. Ixx and Sxx are effective section properties for deflection and bending.
2. Allowable load is calculated in accordance with AISI 2016 specifications considering bending, shear, combined bending and shear and deflection. Allowable load considers the 3 or more equal spans condition. Allowable load does not address web crippling, fasteners, support material or load testing. Panel weight is not considered.
3. Deflection consideration is limited by a maximum deflection ratio of L/180 of span.
4. Allowable loads do not include a 1/3 stress increase for wind.

PANEL LAP DETAIL

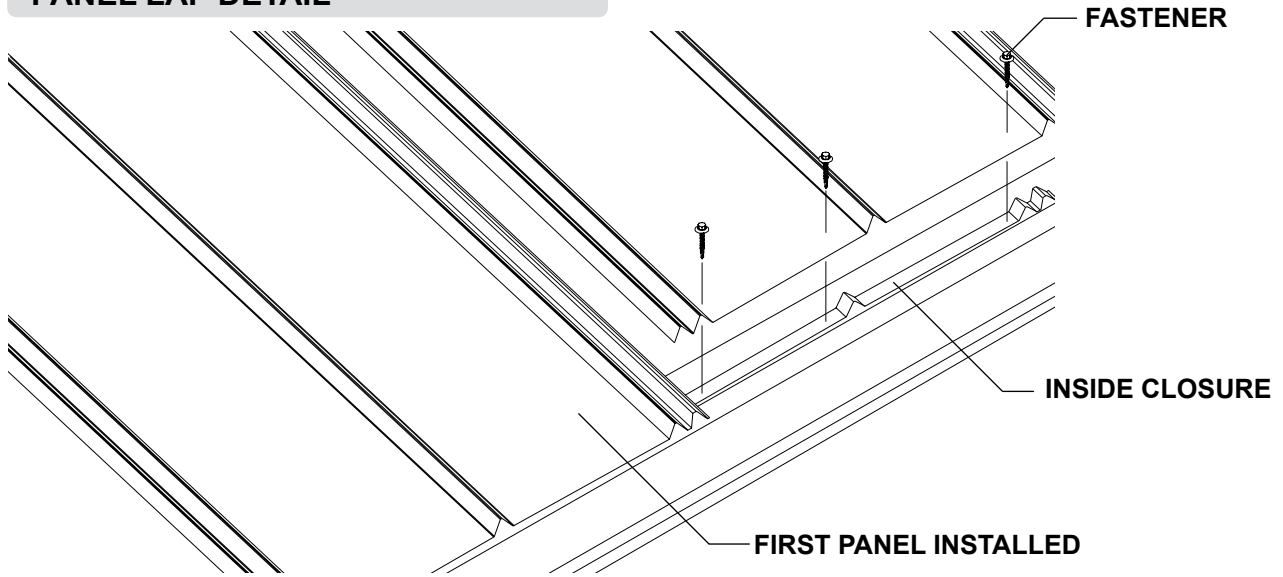

FASTENING PATTERN

FIELD & END OF PANEL

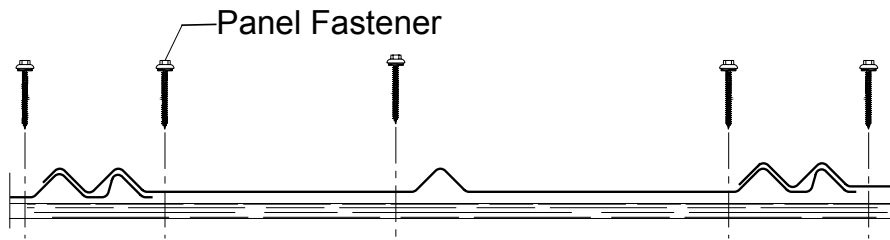

OPTIONAL FASTENING PATTERNS

END OF PANEL

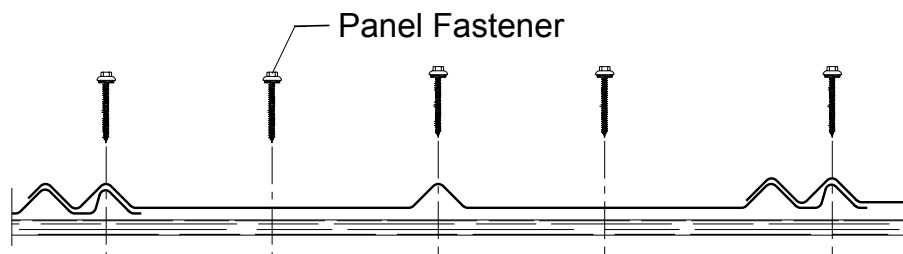

FIELD OF PANEL

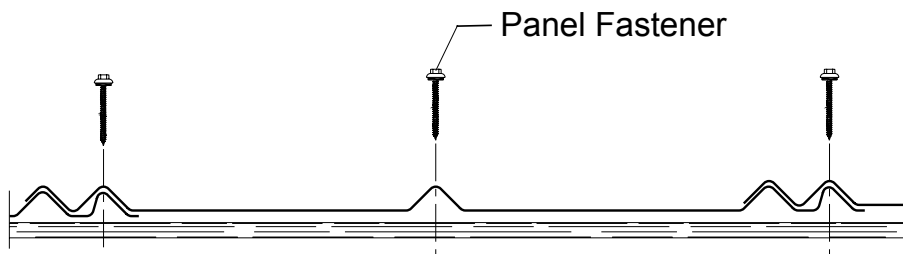

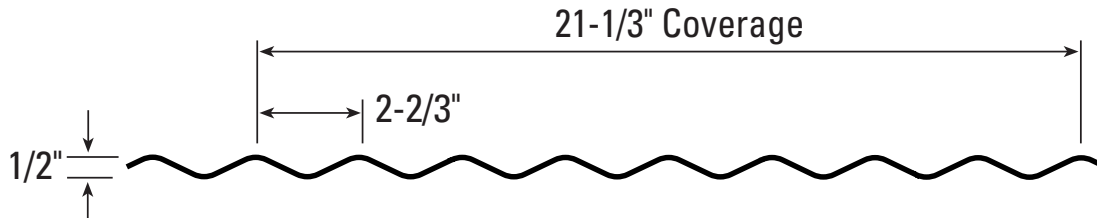

**PANEL OVERVIEW**

- ▶ **Finishes:** MS Colorfast45® and Acrylic Coated Galvalume®
- ▶ **Corrosion Protection:** AZ55 per ASTM A 792 for unpainted Galvalume®  
AZ50 per ASTM A 792 for painted Galvalume®  
G90 per ASTM A 653 for Galvanized
- ▶ **Gauges:** 26 ga standard; 24 ga optional
- ▶ **Panel Length:** Minimum: 5'; Maximum: 45' recommended
- ▶ **Profile:** 21-1/3" panel coverage, 1/2" rib height
- ▶ **Minimum roof slope:** 3:12
- ▶ **Info:** Ribs on 2.66" centers. Applies over plywood with minimum 30# felt underlayment

**TESTING AND APPROVALS**

- ▶ UL 2218 Impact Resistance - Class 4
- ▶ UL 790 Fire Resistance Rating - Class A, per building code
- ▶ UL 263 Fire Resistance Rating - per assembly
- ▶ Texas Windstorm - Evaluation RC-159
- ▶ 2017 FBC Approval - FL14645.1
- ▶ ICC Evaluation Report - ESR-2385

**SECTION PROPERTIES**

SECTION PROPERTIES								ALLOWABLE UNIFORM LOADS, psf For various fastener spacings											
Ga	Width in	Yield ksi	Weight psf	Top In Compression		Bottom In Compression		Inward Load					Outward Load						
				Ixx in <sup>4</sup> /ft	Sxx in <sup>3</sup> /ft	Ixx in <sup>4</sup> /ft	Sxx in <sup>3</sup> /ft	2'	2.5'	3'	3.5'	4'	4.5'	2'	2.5'	3'	3.5'	4'	4.5'
30	21.33	80	0.66	0.0051	0.0202	0.0051	0.0185	107	55	32	20	14	9	107	55	32	20	14	9
29	21.33	80	0.70	0.0056	0.0215	0.0056	0.0208	118	60	35	22	15	10	118	60	35	22	15	10
26	21.33	50	0.90	0.0073	0.0275	0.0073	0.0274	153	78	45	29	19	13	153	78	45	29	19	13
24	21.33	50	1.17	0.0096	0.0354	0.0096	0.0354	200	102	59	37	25	18	200	102	59	37	25	18
22	21.33	50	1.53	0.0124	0.0457	0.0124	0.0457	259	133	77	48	32	23	259	133	77	48	32	23

1. Theoretical section properties have been calculated per AISI 2016 'North American Specification for the Design of Cold-Formed Steel Structural Members'. Ixx and Sxx are effective section properties for deflection and bending.
2. Allowable load is calculated in accordance with AISI 2016 specifications considering bending, shear, combined bending and shear and deflection. Allowable load considers the 3 or more equal spans condition. Allowable load does not address web crippling, fasteners, support material or load testing. Panel weight is not considered.
3. Deflection consideration is limited by a maximum deflection ratio of L/180 of span.
4. Allowable loads do not include a 1/3 stress increase for wind.

ROOF PANEL LAP DETAIL

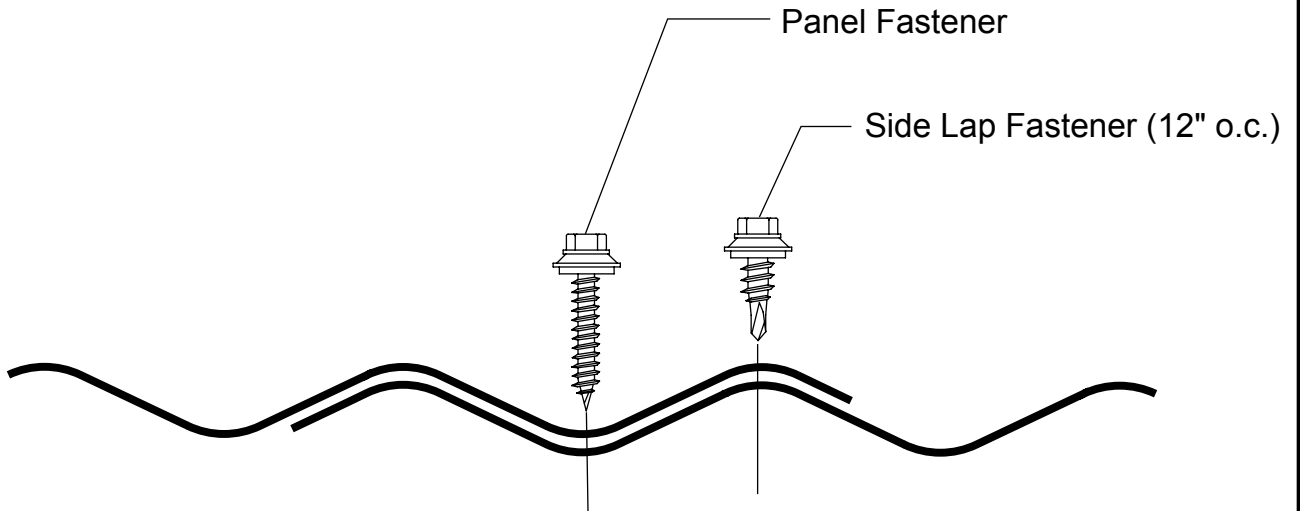

FASTENING PATTERNS

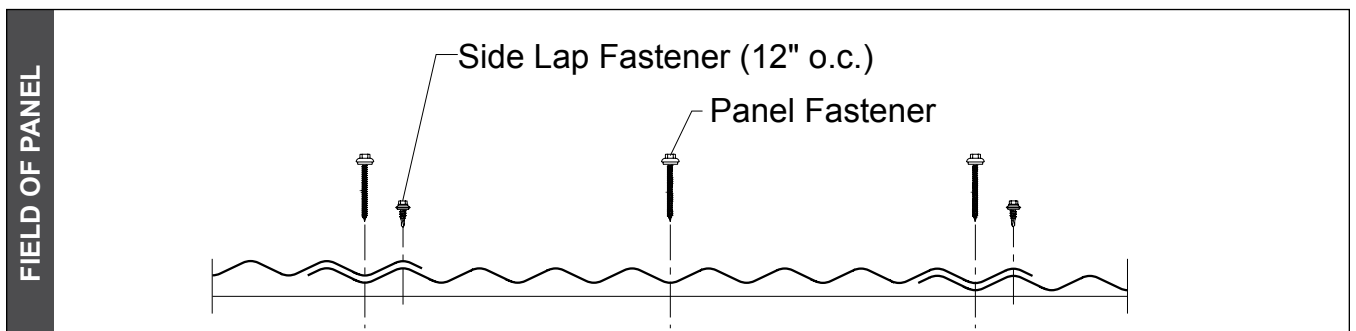
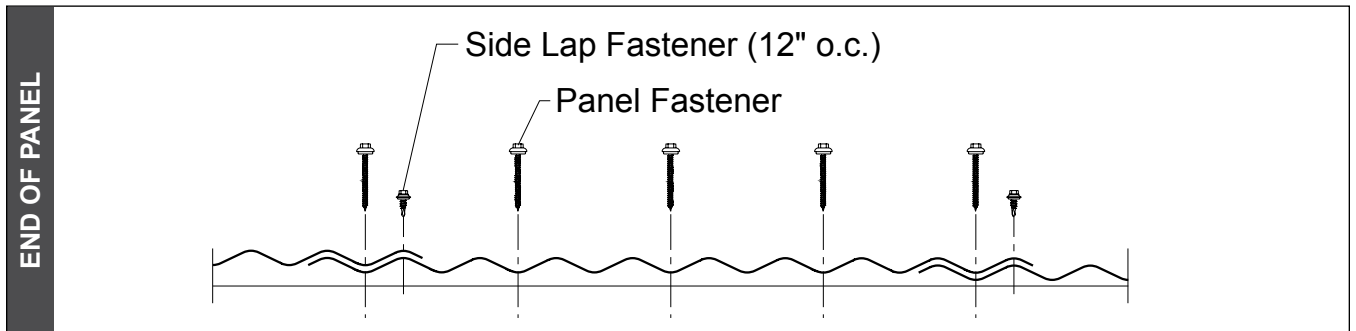

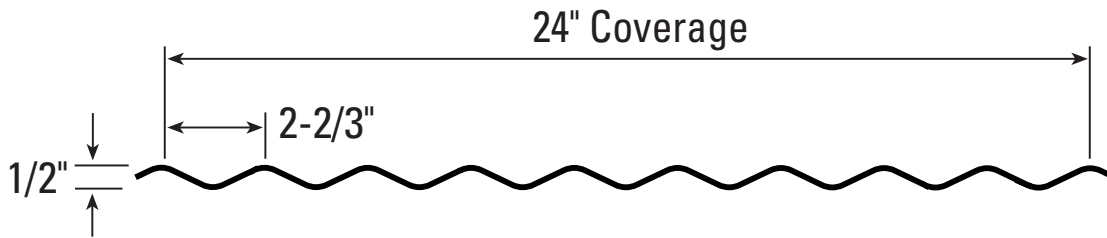

**PANEL OVERVIEW**

- ▶ **Finishes:** MS Colorfast45® and Acrylic Coated Galvalume®
- ▶ **Corrosion Protection:** AZ55 per ASTM A 792 for unpainted Galvalume®  
AZ50 per ASTM A 792 for painted Galvalume®  
G90 per ASTM A 653 for Galvanized
- ▶ **Gauges:** 26 ga standard; 24 ga optional
- ▶ **Panel Length:** Minimum: 5'; Maximum: 45' recommended
- ▶ **Profile:** 24" panel coverage, 1/2" rib height
- ▶ **Minimum roof slope:** 3:12
- ▶ **Info:** Ribs on 2.66" centers. Applies over plywood with minimum 30# felt underlayment

**TESTING AND APPROVALS**

- ▶ UL 2218 Impact Resistance - Class 4
- ▶ UL 790 Fire Resistance Rating - Class A, per building code
- ▶ UL 263 Fire Resistance Rating - per assembly

**SECTION PROPERTIES**

SECTION PROPERTIES								ALLOWABLE UNIFORM LOADS, psf For various fastener spacings											
Ga	Width in	Yield ksi	Weight psf	Top In Compression		Bottom In Compression		Inward Load						Outward Load					
				Ixx in <sup>4</sup> /ft	Sxx in <sup>3</sup> /ft	Ixx in <sup>4</sup> /ft	Sxx in <sup>3</sup> /ft	2'	2.5'	3'	3.5'	4'	4.5'	2'	2.5'	3'	3.5'	4'	4.5'
30	24	80	0.59	0.0045	0.0180	0.0045	0.0165	96	49	28	18	12	8	96	49	28	18	12	8
29	24	80	0.62	0.0050	0.0191	0.0050	0.0185	105	54	31	20	13	9	105	54	31	20	13	9
26	24	50	0.80	0.0065	0.0245	0.0065	0.0244	136	70	40	25	17	12	136	70	40	25	17	12
24	24	50	1.04	0.0085	0.0315	0.0085	0.0315	178	91	53	33	22	16	178	91	53	33	22	16
22	24	50	1.36	0.0110	0.0407	0.0110	0.0407	230	118	68	43	29	20	230	118	68	43	29	20

1. Theoretical section properties have been calculated per AISI 2016 'North American Specification for the Design of Cold-Formed Steel Structural Members'. Ixx and Sxx are effective section properties for deflection and bending.
2. Allowable load is calculated in accordance with AISI 2016 specifications considering bending, shear, combined bending and shear and deflection. Allowable load considers the 3 or more equal spans condition. Allowable load does not address web crippling, fasteners, support material or load testing. Panel weight is not considered.
3. Deflection consideration is limited by a maximum deflection ratio of L/180 of span.
4. Allowable loads do not include a 1/3 stress increase for wind.



WALL PANEL LAP DETAIL

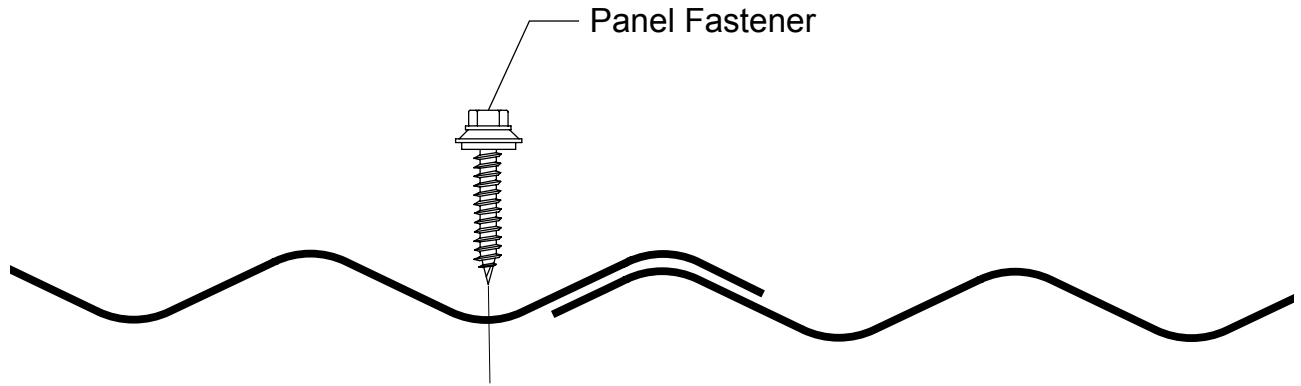

FASTENING PATTERN

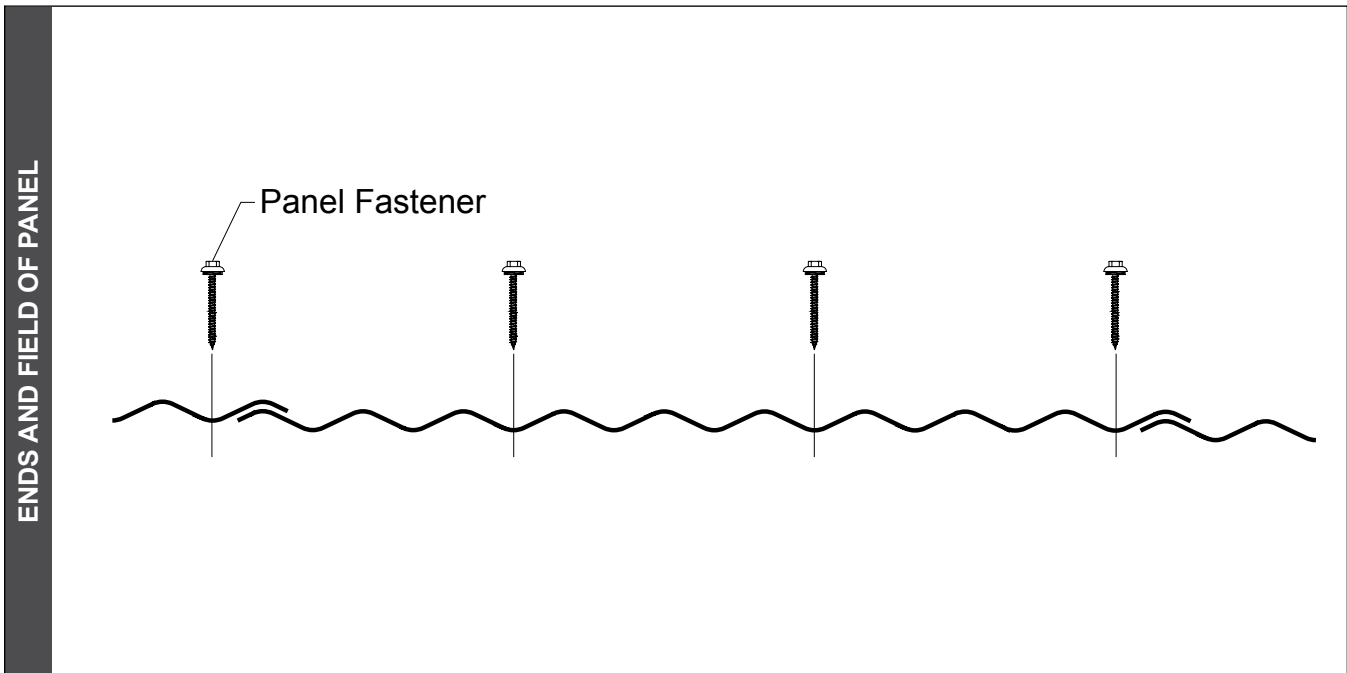

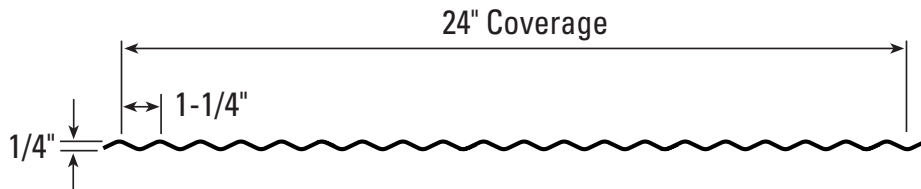

**PANEL OVERVIEW**

- ▶ **Finishes:** MS Colorfast45® and Acrylic Coated Galvalume®
- ▶ **Corrosion Protection:** AZ55 per ASTM A 792 for unpainted Galvalume®  
AZ50 per ASTM A 792 for painted Galvalume®  
G90 per ASTM A 653 for Galvanized
- ▶ **Gauges:** 26 ga standard; 24 ga optional
- ▶ **Panel Length:** Minimum: 3'; Maximum: 30' recommended
- ▶ **Profile:** 24" panel coverage, 1/2" rib height
- ▶ **Minimum roof slope:** 3:12
- ▶ **Info:** Ribs on 1.25" centers. Applies over plywood with minimum 30# felt underlayment

**TESTING AND APPROVALS**

- ▶ UL 2218 Impact Resistance - Class 4
- ▶ UL 790 Fire Resistance Rating - Class A, per building code
- ▶ UL 263 Fire Resistance Rating - per assembly

**SECTION PROPERTIES**

SECTION PROPERTIES								ALLOWABLE UNIFORM LOADS, psf For various fastener spacings											
Ga	Width in	Yield ksi	Weight psf	Top In Compression		Bottom In Compression		Inward Load						Outward Load					
				Ixx in <sup>4</sup> /ft	Sxx in <sup>3</sup> /ft	Ixx in <sup>4</sup> /ft	Sxx in <sup>3</sup> /ft	1'	1.25'	1.5'	1.75'	2'	2.5'	1'	1.25'	1.5'	1.75'	2'	2.5'
30	24	80	0.61	0.0010	0.0066	0.0010	0.0063	167	86	50	31	21	11	167	86	50	31	21	11
29	24	80	0.64	0.0010	0.0070	0.0010	0.0067	167	86	50	31	21	11	167	86	50	31	21	11
26	24	50	0.81	0.0015	0.0087	0.0015	0.0085	196	126	74	47	31	16	202	113	65	41	27	14

1. Theoretical section properties have been calculated per AISI 2016 'North American Specification for the Design of Cold-Formed Steel Structural Members'. Ixx and Sxx are effective section properties for deflection and bending.
2. Allowable load is calculated in accordance with AISI 2016 specifications considering bending, shear, combined bending and shear and deflection. Allowable load considers the 3 or more equal spans condition. Allowable load does not address web crippling, fasteners, support material or load testing. Panel weight is not considered.
3. Deflection consideration is limited by a maximum deflection ratio of L/180 of span.
4. Allowable loads do not include a 1/3 stress increase for wind.

PANEL LAP DETAIL

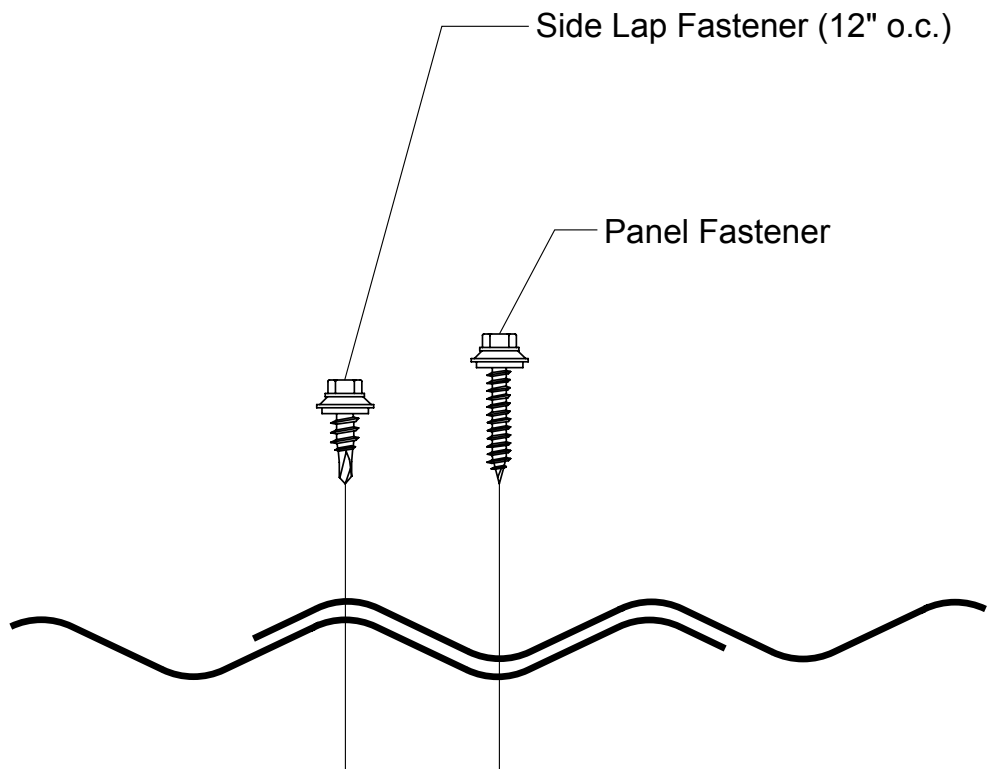

FASTENING PATTERN

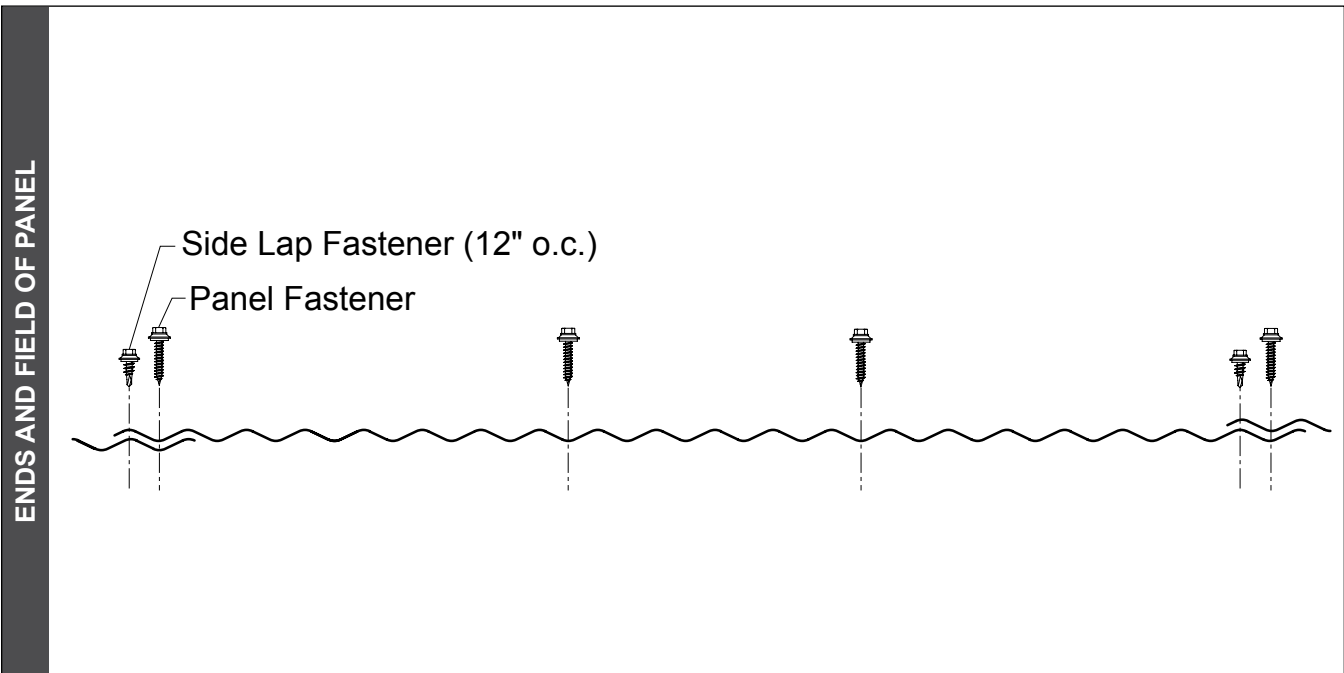

**USING SCREWS:**

For fastening with screws, it is best to use a painted or plated screw, Type A or driller tip with a flat rubber washer. The correct screw gun is also important to the proper installation of self-drilling or self-tapping screws. A tool with the appropriate speed and torque setting (as recommended by the fastener manufacturer) will help prevent fastener thread strip-out and possible damage to the panel or its coating. Typically 40 screws should be used per square for 2' wide panels and 80 screws should be used per square for 3' wide panels.

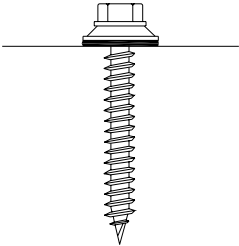
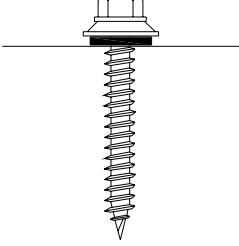
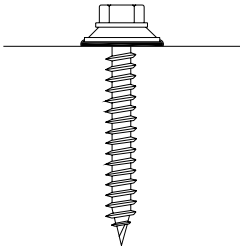
<p><b>CORRECT</b> Sealing material slightly visible at edge of washer. Assembly is water tight.</p>	<p><b>TOO LOOSE</b> Sealing material is not visible; not enough compression to seal.</p>	<p><b>TOO TIGHT</b> Washer is deformed; sealing material pressed beyond fastener edge.</p>
		

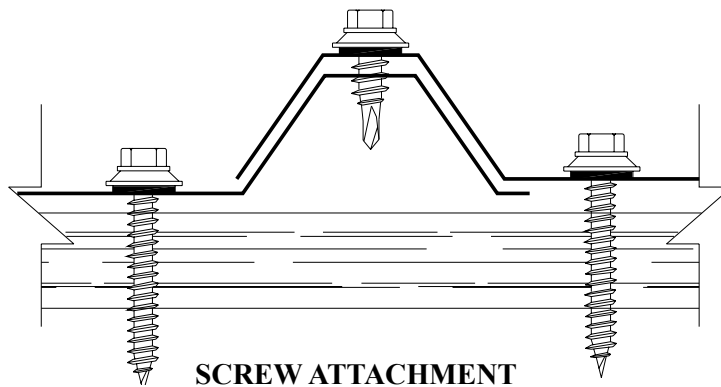

**SEATING THE WASHER** - Apply sufficient torque to seat the washer - do not overdrive the fastener.

**TO PREVENT WOBBLING** - Make sure fastener head is completely engaged in the socket. If the head does not go all the way in the socket - tap the magnet deeper into the socket to allow full head engagement. Metal chips will build up from drilling and should be removed from time to time.

**PROTECT DRILL POINT** - Push only hard enough on the screw gun to engage clutch. This prevents excess friction and burn out of the drill point. Correct pressure will allow screw to drill and tap without binding.

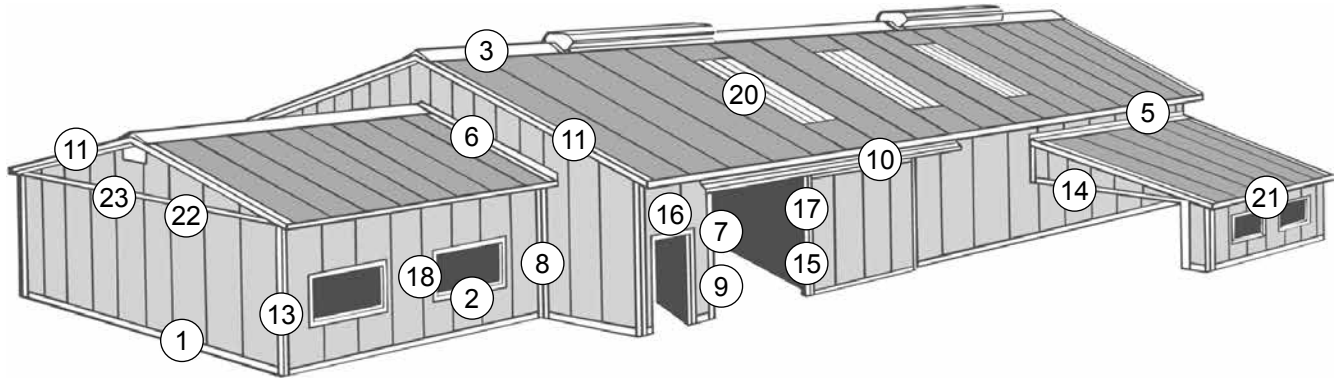

**1▶ BASE MOLDING**

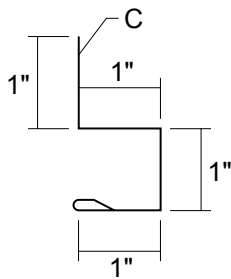

**1▶ ANGLE BASE**

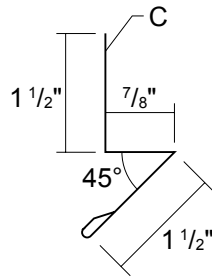

**2▶ J-CHANNEL**

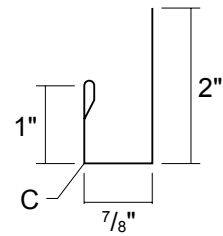

**3▶ 14" UNIVERSAL RIDGE**

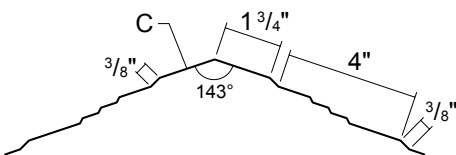

**3▶ 20" UNIVERSAL RIDGE**

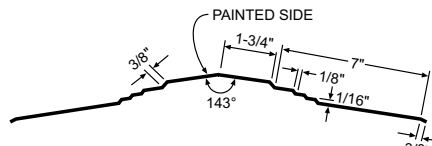

**4▶ SOFFIT**

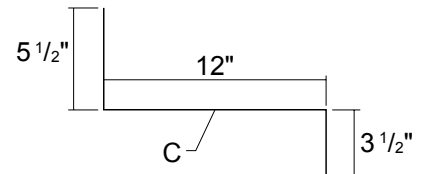

**4▶ 12" SOFFIT**

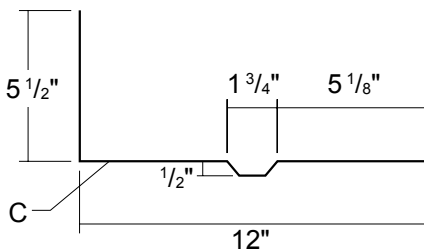

**4▶ 24" SOFFIT**

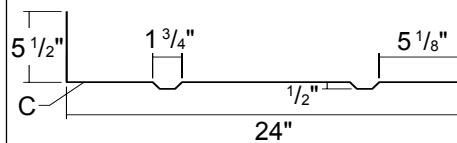

**5▶ UNIVERSAL ENDWALL**

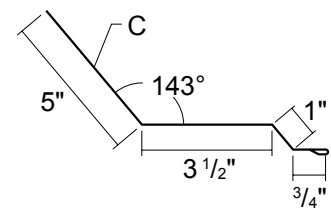

**6► UNIVERSAL SIDEWALL**

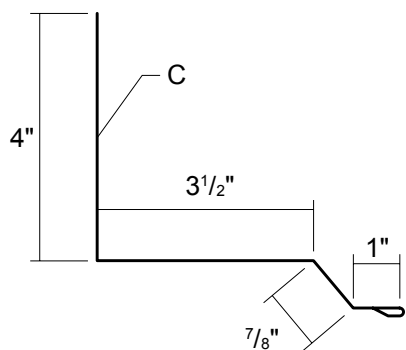

**7► MINI ANGLE**

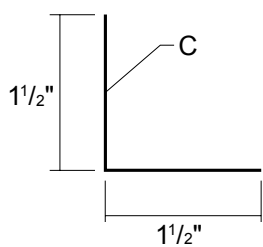

**8► INSIDE CORNER**

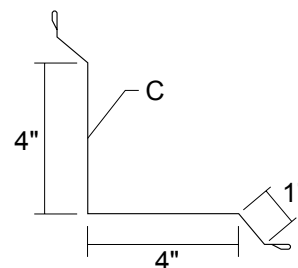

**9► POST TRIM**

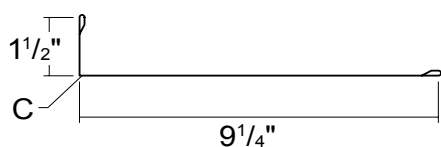

**10► NATIONAL TRACK COVER**

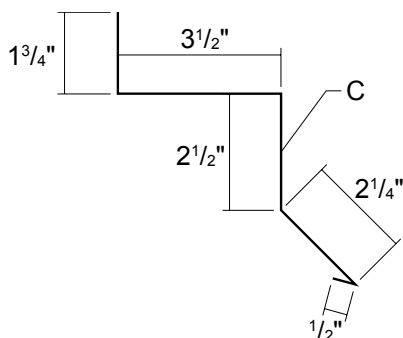

**10► TOP MOUNT TRACK COVER**

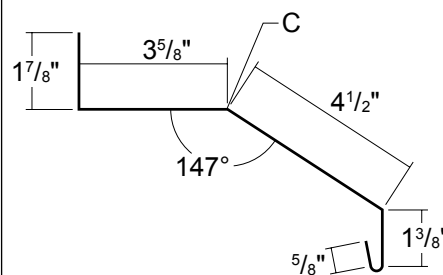

**10► CANNONBALL TRACK COVER**

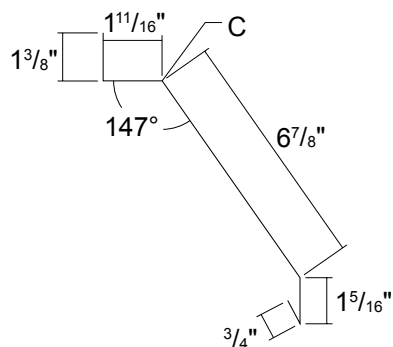

**11► GABLE TRIM**

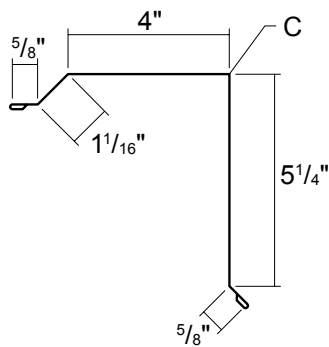

**11► RAKE TRIM**

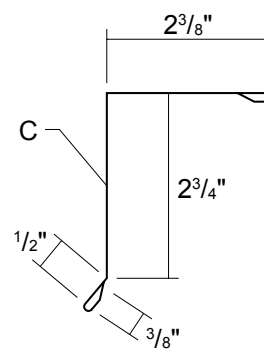

**13► OUTSIDE CORNER**

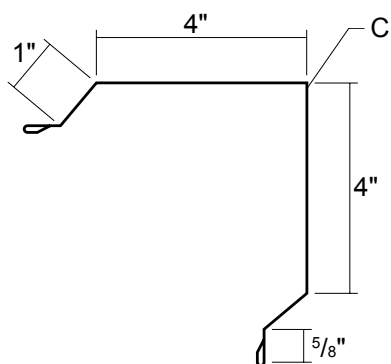

**14► OVERHEAD DOOR TRIM**

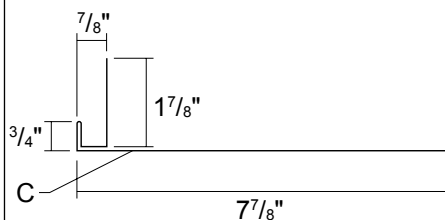

**15► DOOR JAMB**

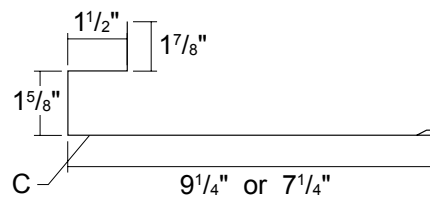

**16▶ DRIP CAP**

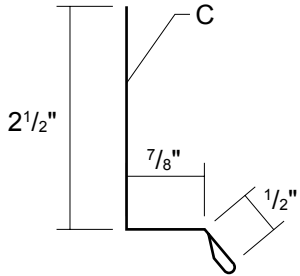

**17▶ DOOR POST TRIM**

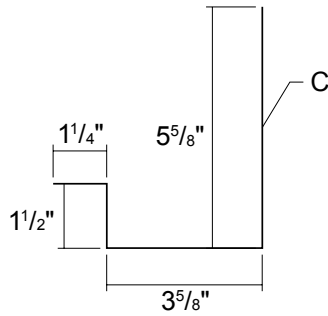

**18▶ FRAMING CLOSURE**

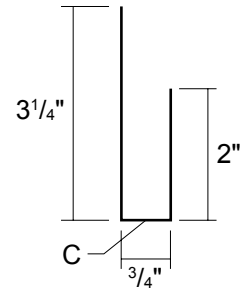

**20▶ TRANSLUCENT PANEL**

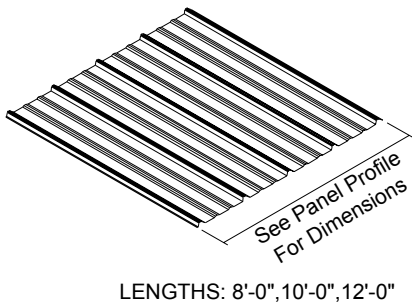

**21▶ EAVE MOLDING**

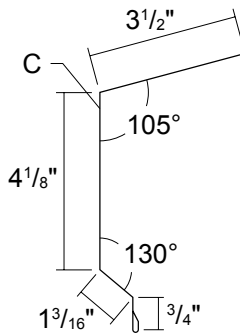

**22▶ DOUBLE ANGLE**

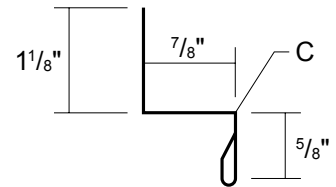

**23▶ WIDE Z-METAL**

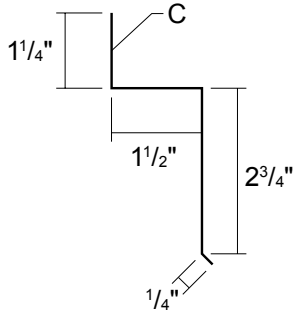

**24▶ UNIVERSAL GAMBREL**

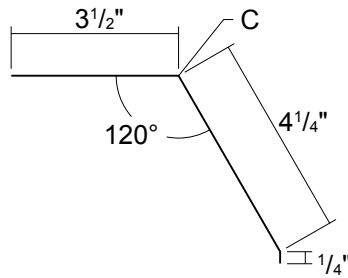

**25▶ RAKE/EAVE TRIM**

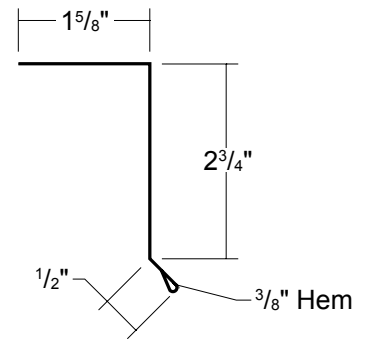

**26▶ 3/8" F&J CHANNEL**

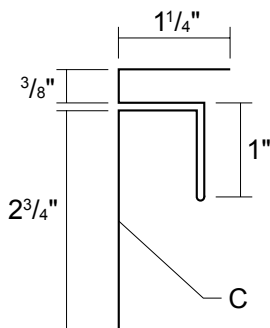

**26▶ 3/4" F&J CHANNEL**

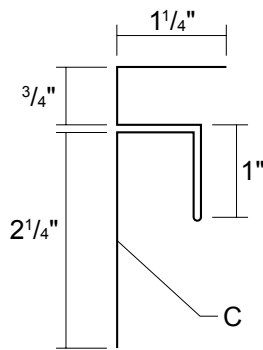

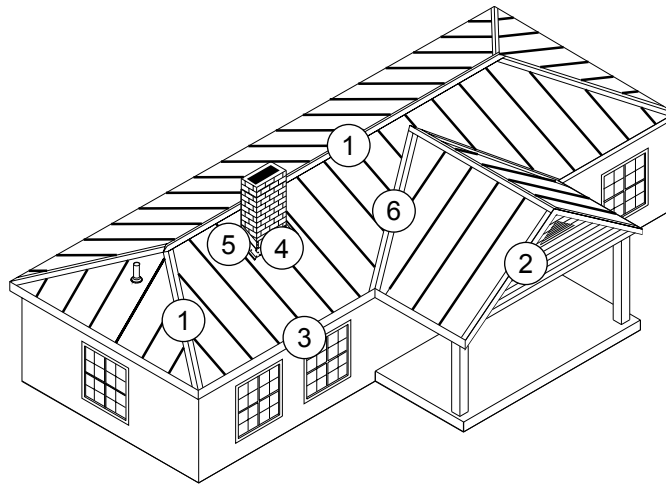

**1▶ 14" UNIVERSAL RIDGE COVER**

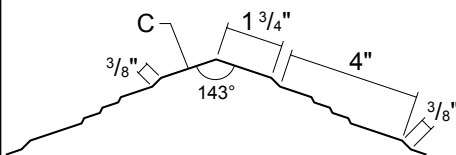

**1▶ RIDGE / HIP COVER**

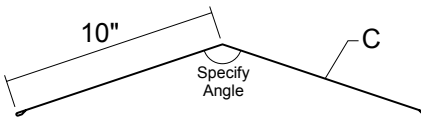

**1▶ 13" STEP RIDGE / HIP COVER**

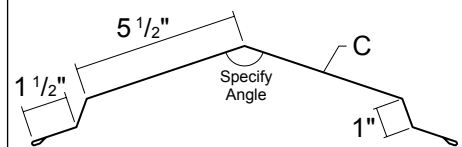

**2▶ GABLE TRIM**

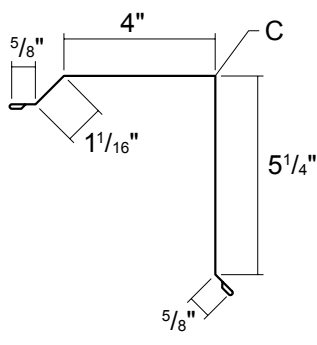

**3▶ EAVE TRIM**

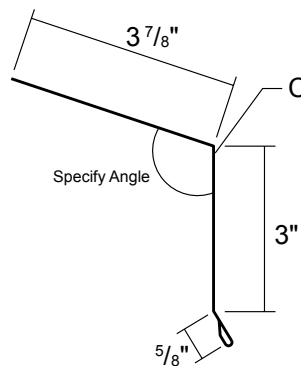

**4▶ UNIVERSAL ENDWALL**

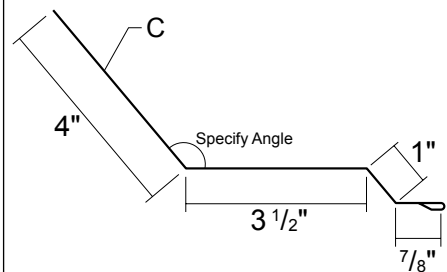

**4▶ PITCH BREAK**

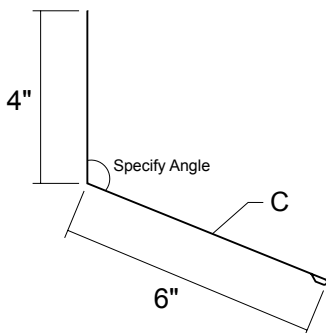

**5▶ UNIVERSAL SIDEWALL**

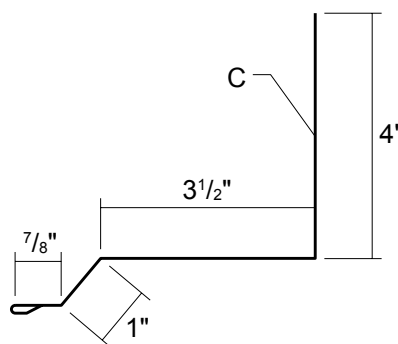



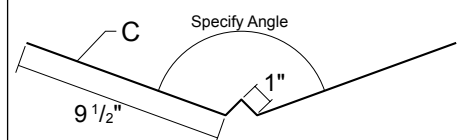







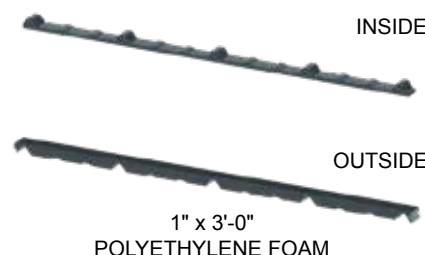
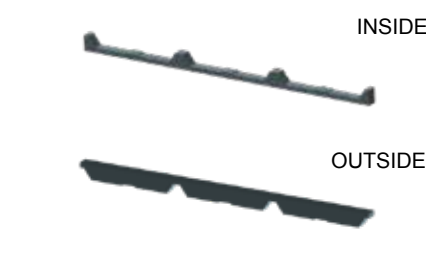
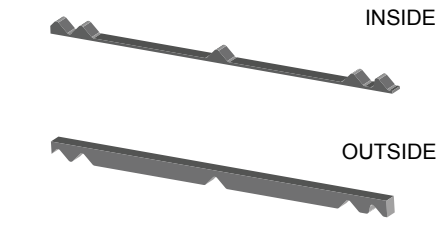

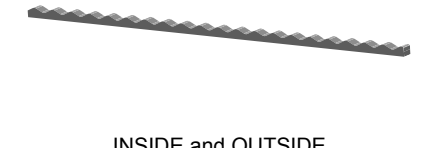
**6▶ VALLEY**





# POST FRAME ACCESSORY PROFILES



<p><b>CLASSIC RIB CLOSURES</b></p>  <p>INSIDE</p> <p>OUTSIDE</p> <p>1" x 3'-0" POLYETHYLENE FOAM</p>	<p><b>PRO-PANEL II CLOSURES</b></p>  <p>INSIDE</p> <p>OUTSIDE</p> <p>1" x 3'-0" POLYETHYLENE FOAM</p>	<p><b>DELTA RIB CLOSURES</b></p>  <p>INSIDE</p> <p>OUTSIDE</p>
<p><b>5V-CRIMP CLOSURES</b></p>  <p>INSIDE</p> <p>OUTSIDE</p>	<p><b>2.5" CORRUGATED CLOSURE</b></p>  <p>INSIDE and OUTSIDE</p>	<p><b>1.25" CORRUGATED CLOSURE</b></p>  <p>INSIDE and OUTSIDE</p>
<p><b>UNIVERSAL CLOSURE</b></p>  <p>1" x 1 1/2" x 50'-0" 1" x 1 1/2" x 10'-0"</p>	<p><b>X10 VERSAVENT</b></p>  <p>10'-0" LENGTHS</p>	<p><b>PROFILE VENT</b></p>  <p>2 COILS OF 50'-0" (ONE EACH SIDE) COVERS 50'-0" OF RIDGE</p>
<p><b>TUBE SEALANT</b></p>  <p>10.3 oz. CARTRIDGE URETHANE</p>	<p><b>ms-HT UNDERLAYMENT</b></p>  <p>2.5 SQUARES PER ROLL</p>	<p><b>TOUCH-UP PAINT</b></p>  <p>10.5 OZ</p>
<p><b>SINGLE BEAD TAPE SEALANT</b></p>  <p>3/8" X 3/32" X 50' BUTYL - GRAY</p>	<p><b>DOUBLE BEAD TAPE SEALANT</b></p>  <p>3/8" X 3/32" X 25' BUTYL - GRAY</p>	<p><b>RUBBER ROOF JACK</b></p>  <p>MINI (1/4" TO 1 1/8" O.D. PIPE) #2 (1 3/4" TO 3" O.D. PIPE) #4 (3" TO 6" O.D. PIPE) #6 (6" TO 9" O.D. PIPE) #8 (7" TO 13" O.D. PIPE)</p>

## RECEIVING MATERIAL

It is the responsibility of the installer to unload material from the delivery truck. The installer shall be responsible for providing suitable equipment for unloading of material from the delivery.

After receiving material, check the condition of the material, and review the shipment against the shipping list to ensure all materials are accounted for. If damages or shortages are discovered, it should be noted on the Bill of Lading at the time of delivery. A claim should be made against the carrier as soon as possible. Metal Sales is not responsible for any damages or shortages unless they are documented in writing and presented to Metal Sales within 48 hours.

## GENERAL HANDLING

Each bundle should be handled carefully to avoid being damaged. Care should be taken to prevent bending of the panel or abrasion to finish. Whenever possible, the bundle should remain crated until it is located in its place of storage. If bundles must be opened, we recommend you re-crate them before lifting. To avoid damage please lift the bundle at its center of gravity.

### CAUTION

**Improper loading and unloading of bundles and crates may result in bodily harm and/or material damage. Metal Sales is not responsible for bodily injuries and/or material damages resulting from improper loading and unloading.**

## MECHANICAL HANDLING

**Forklift** - A forklift may be used for panels up to 20'-0" long. Please make sure the forks are at their maximum separation. Do not transport open bundles. When transporting bundles across rough terrain, or over a longer distance, some means of supporting the panel load must be used.

**Crane** - A crane should be used when lifting panels with lengths greater than 20'-0". Please be sure to utilize a spreader bar to ensure the even distribution of the weight to the pick up points. As a rule when lifting panels, no more than  $\frac{1}{3}$  of the length of the panel should be left unsupported. Never use wire rope because this will damage the panels.

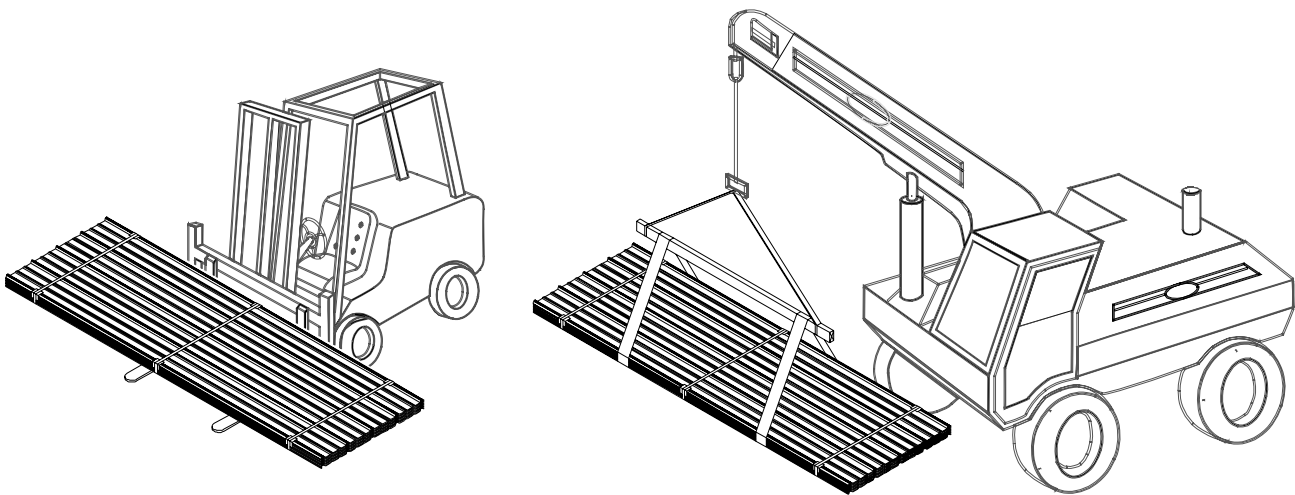

**MANUAL HANDLING**

When handling painted steel, care should be taken to prevent scratching of material. Clean gloves should be worn at all times to prevent a reaction with salts found on bare skin. Installers should wear rubber sole shoes to keep from scuffing material while walking on the roof.

Handling of individual panels should be done carefully and properly to avoid bending or damaging. Panels should be carried by grasping the edge of the panel so that the panel is vertical to the ground. The panel should not be carried horizontal to the ground as this could cause the panel to buckle or bend in the center.

Normally, individual panels can be handled by people placed every 6'-0" to 8'-0" along the length of the panel.

**CORRECT**

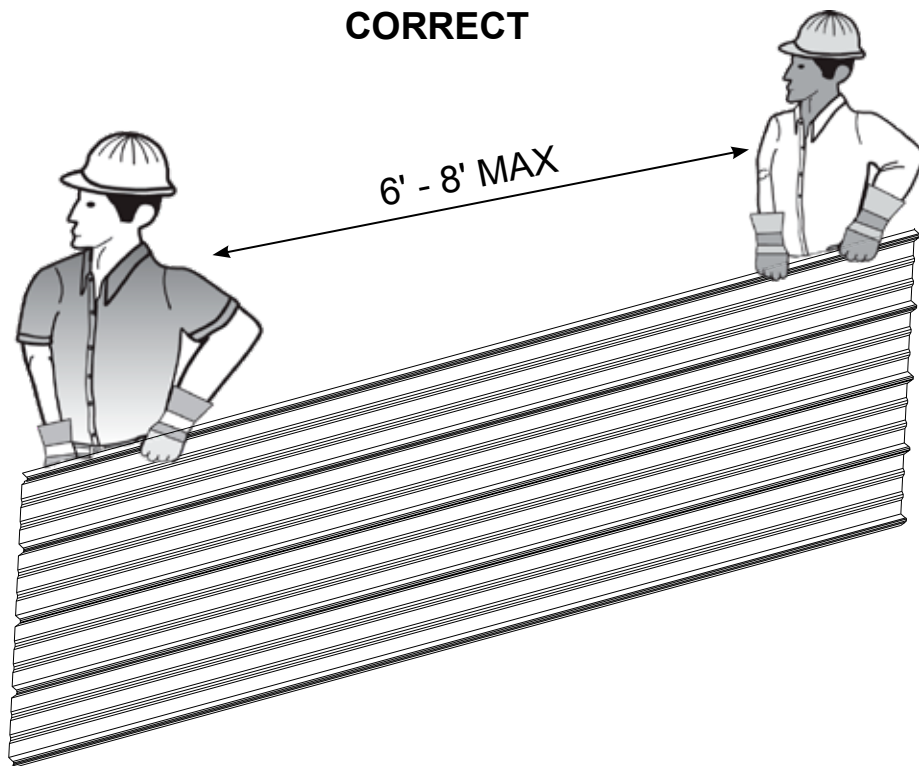

**INCORRECT**

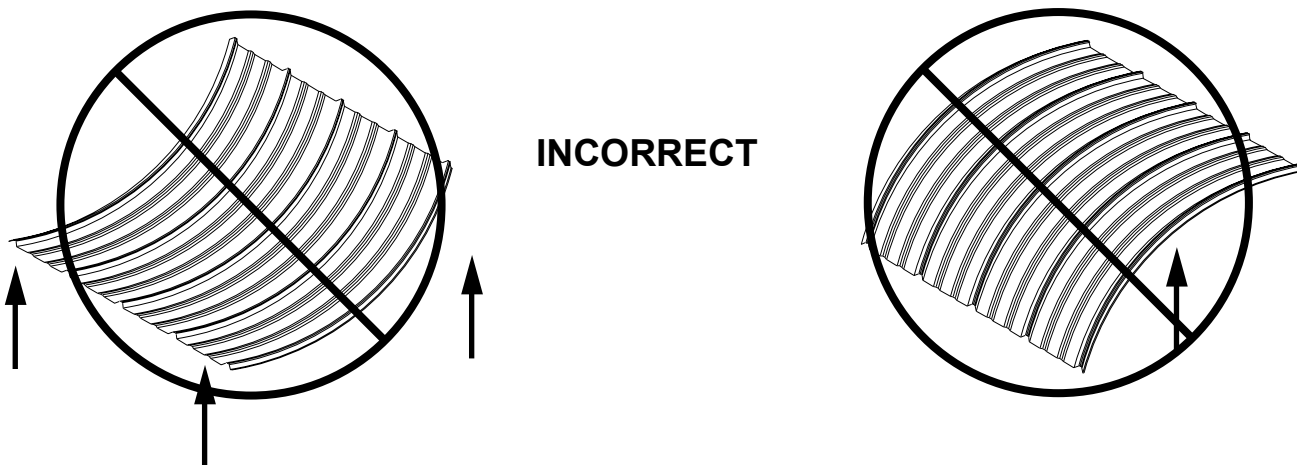

## GENERAL

Please inspect panels for moisture accumulation. If moisture has formed, the panels should be unbundled, wiped dry, and allowed to dry completely. Once dry, carefully re-stack the panels and loosely recover allowing for ample air circulation.

Bundled sheets should be stored high enough off of the ground to allow for air circulation and prevent contact with accumulating water. Elevate one end of the bundle to allow any moisture to run off the panels. Metal Sales recommends covering the bundle with a Tarp. Do not use tight fitting plastic-type Tarp as panel bundle covers. While they may provide protection from heavy downpours, they can also retard necessary ventilation and trap heat and moisture that may accelerate metal corrosion. If panels are to be stored in possible bad weather, we suggest they be stored inside. Extended storage of panels in a bundle is not recommended. **Under no circumstances should the panels be stored near or come in contact with salt water, corrosive chemicals, ash or fumes generated or released inside the building or nearby plants, foundries, plating works, kilns, fertilizer and wet or green lumber.**

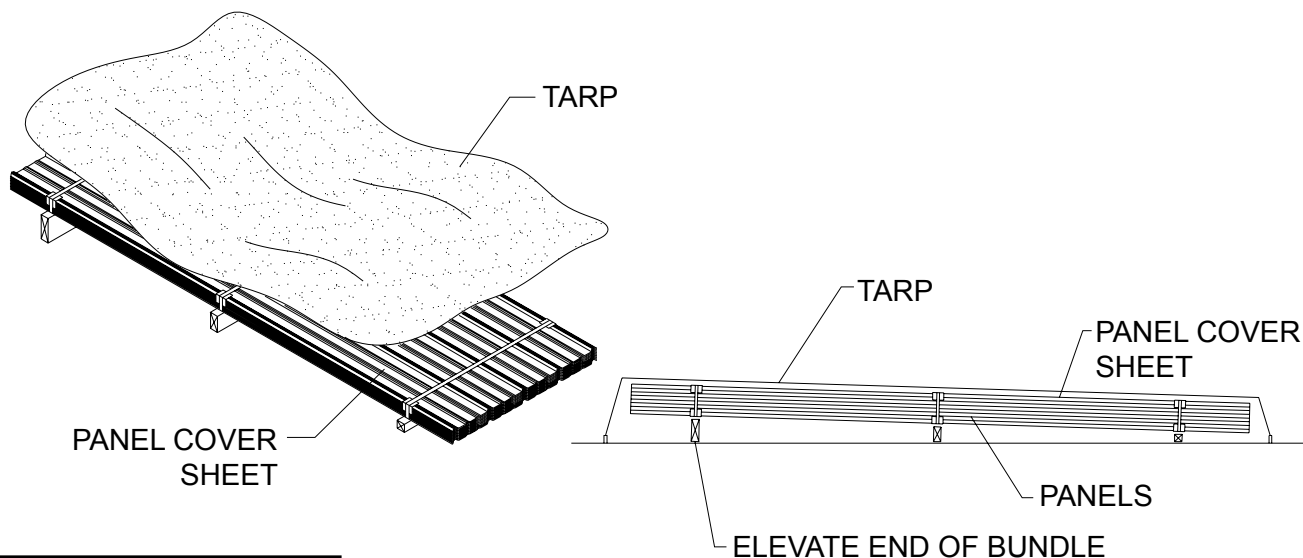

## FOOT TRAFFIC

Care of metal panels and flashings must be exercised throughout erection. Foot traffic can cause distortion of panel and damage to finish. Traffic over the installed system must be kept to an absolute minimum. Installers should wear rubber sole shoes to keep from scuffing material while walking on the roof.

When walking on the roof panels is unavoidable, walk only in the flats of the panel. Walking on the ribs can cause damage to the panels.

## REQUIRED TOOLS

Standard required tools for field installation include:

- Screw Guns
- Magnetic Bits
- Metal Nibbler or Shear
- Tin Snips
- Tape Measure
- Hammer
- Chalk Line
- Drill with bits
- Pop Rivet Gun
- Safety Goggles
- Gloves
- Ear Plugs
- Fall Protection

**GENERAL**

Metal Sales' panels are designed to be installed over open framing and/or directly over a wood substrate (minimum 5/8") with 30# felt moisture barrier (or an Ice and Water Shield when required by Local Building Codes).

Always check with local building codes prior to all installations for any additional requirements that may be specific to your area.

Galvanized and Galvalume panels should not be in contact with, or subject to, water runoff from copper, lead or uncoated steel materials.

Condensate water from air conditioning units typically contains dissolved copper. This condensate should be discharged through a plastic pipe extended beyond the edge of the roof.

There are two critical measurements involving metal panels: the length of panel overhang required at the eave, and the peak end. In each case a certain measurement is required. Check each measurement to ensure panel placement gives you the distance required at the eave, and peak condition. In most cases any variance can be taken out at the eave or peak ends.

**CONDITION OF SUBSTRUCTURE**

The roof should be inspected for any trapped moisture or structural damage such as bowing or sagging rafters and warped or loose roof purlins or solid decking. These areas should be repaired prior to installing new metal panels.

Prior to installation, make sure there are no nails or fasteners protruding from the roof framing or wood substrate which could damage the panels and impede the installation process.

When installed, panel distortion may occur if not applied over properly aligned and uniform substructure.

Whether installing over new or existing roof, the installer should check the roof deck for squareness before installing panels. Several methods can be used to verify squareness of the structure for proper installation of the panels.

METHOD "A" - One method for checking the roof for squareness is to measure diagonally across one slope of the roof from similar points at the ridge and eave and obtain the same dimension.

METHOD "B" - The 3-4-5 triangle system may also be used. To use this system, measure a point from the corner along the edge of the roof at a module of three (3). Measure a point from the same corner along another edge at a module of four (4). By measuring diagonally between the two points established, the dimension should be exactly a module of five (5) to have a square corner. Multiple uses of this system may be required to determine building squareness. If the endwall cannot be made square, the roof system cannot be installed as shown in these instructions.

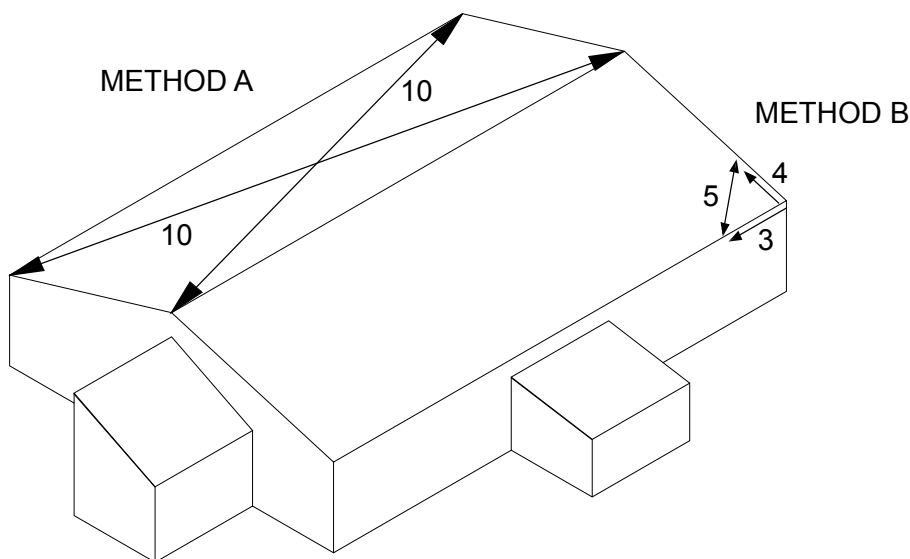

**FIELD CUTTING**

Tin snips or a "nibbler" type electric tool are recommended for field cutting metal panels. Cutting the steel generates slivers or metal chips. These slivers and metal chips must be immediately removed from the panels because they will damage the finish and shorten the life of the product.

One method of preventing this problem is to flip the panels over when cutting. This allows the slivers and metal chips to be brushed from the back side and avoids damaging the paint on the top side of the panels.

When cutting metal panels and flashings, goggles must be worn for eye protection.

**CAUTION**  
All product surfaces should be free of debris at all times. Installed surfaces should be wiped clean at the end of each work period. Never cut panels over metal surfaces. Metal shavings will rust on the surface, voiding the warranty.

**TOUCH-UP PAINT**

All painted panels and flashings have a factory applied baked on finish. Handling and installing panels may result in some small scratches or nicks to the paint finish. Touch-up paint is available in matching colors from Metal Sales. It is recommended that a small brush be used to apply touch-up paint to those areas that are in need of repair. Touch-up paint does not have the superior chalk and fade resistance of the factory applied paint finish and will normally discolor at an accelerated rate. Aerosol paint should not be used because of the overspray that may occur.

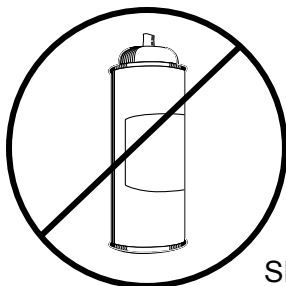

SPRAY PAINT

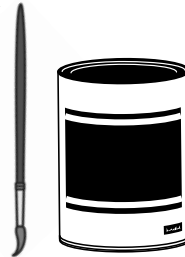

TOUCH-UP PAINT

**VENTILATION**

Proper design and installation of vapor barriers and ventilation systems are important to prevent condensation and the resulting problems of moisture damage and loss of insulation efficiency.

Condensation occurs when moisture laden air comes in contact with a surface temperature equal to or below the dew point of the air. This phenomenon creates problems that are not unique with metal buildings; these problems are common to all types of construction.

The underside of the metal roof on a typical metal building (no attic) should be protected from condensation by insulating with a faced insulation. This should reduce the potential of condensation forming on the underside of the panels. On buildings that have an attic space or are being retrofitted with a metal roofing system, vents should be placed at both the eave and peak of the roof in order to prevent a buildup of moisture (humidity) in the attic space.

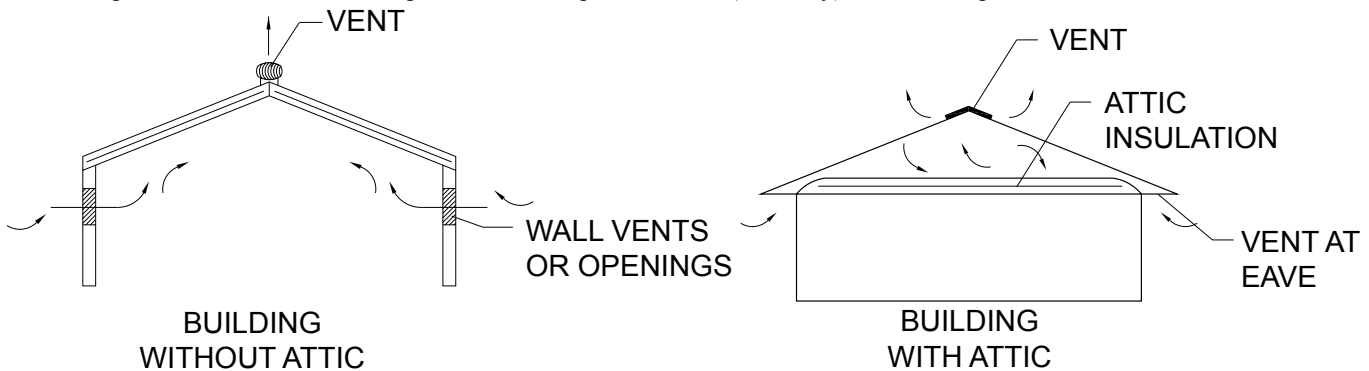

**POP RIVET**



**SIZE**

1/8" x 3/8"

**TYPE**

A

**FINISH**

Unpainted

**APPLICATION**

Flashing to Panel,  
Flashing to Flashing

1/8" x 3/8"

A

Painted

Flashing to Panel,  
Flashing to Flashing

**PANCAKE HEAD WOODSCREW**

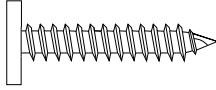

**SIZE**

#10-12 x 1"

**TYPE**

A

**FINISH**

Plated

**APPLICATION**

Panel or Flashing to  
wood substructure

**WOODSCREW**

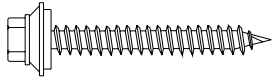

**SIZE**

#10-14 x 1"  
#10-14 x 1 1/2"  
#10-14 x 2"

**TYPE**

A  
A  
A

**FINISH**

Painted  
Painted  
Painted

**APPLICATION**

Panel or Flashing  
to wood substructure

**STITCH SCREW**

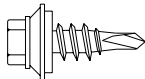

**SIZE**

1/4" - 14 x 7/8"

**TYPE**

Stitch

**FINISH**

Painted

**APPLICATION**

Flashing to Panel,  
Flashing to Flashing,  
Panel Sidelap

## INSTALLATION OVERVIEW

- ▶ As shown below with the number designations, install panel against the prevailing wind. Installing Wall Panels first then Roof Panels
- ▶ To minimize corrosion, siding panels should not be installed all the way to the ground.
- ▶ Siding panels should lap over the foundations or splash boards at least three inches.
- ▶ Make sure panels are square and plumb, to assure straight and proper alignment of the entire row of panels.
- ▶ For areas with high wind considerations, closer fastener spacing may be required.
- ▶ It is necessary to attach a temporary guide to the foundation to use as an alignment guide when installing siding panels.
- ▶ Anti-Siphon groove side of panel must be overlapped with the non siphon groove side of the adjacent panel (if applicable)
- ▶ **When endlapping panels: at the side laps, both of the ridge panels must overlap both eave panels.**
- ▶ **At Endlaps apply Tape Sealant across the full width of the upper end of the eave panels.**

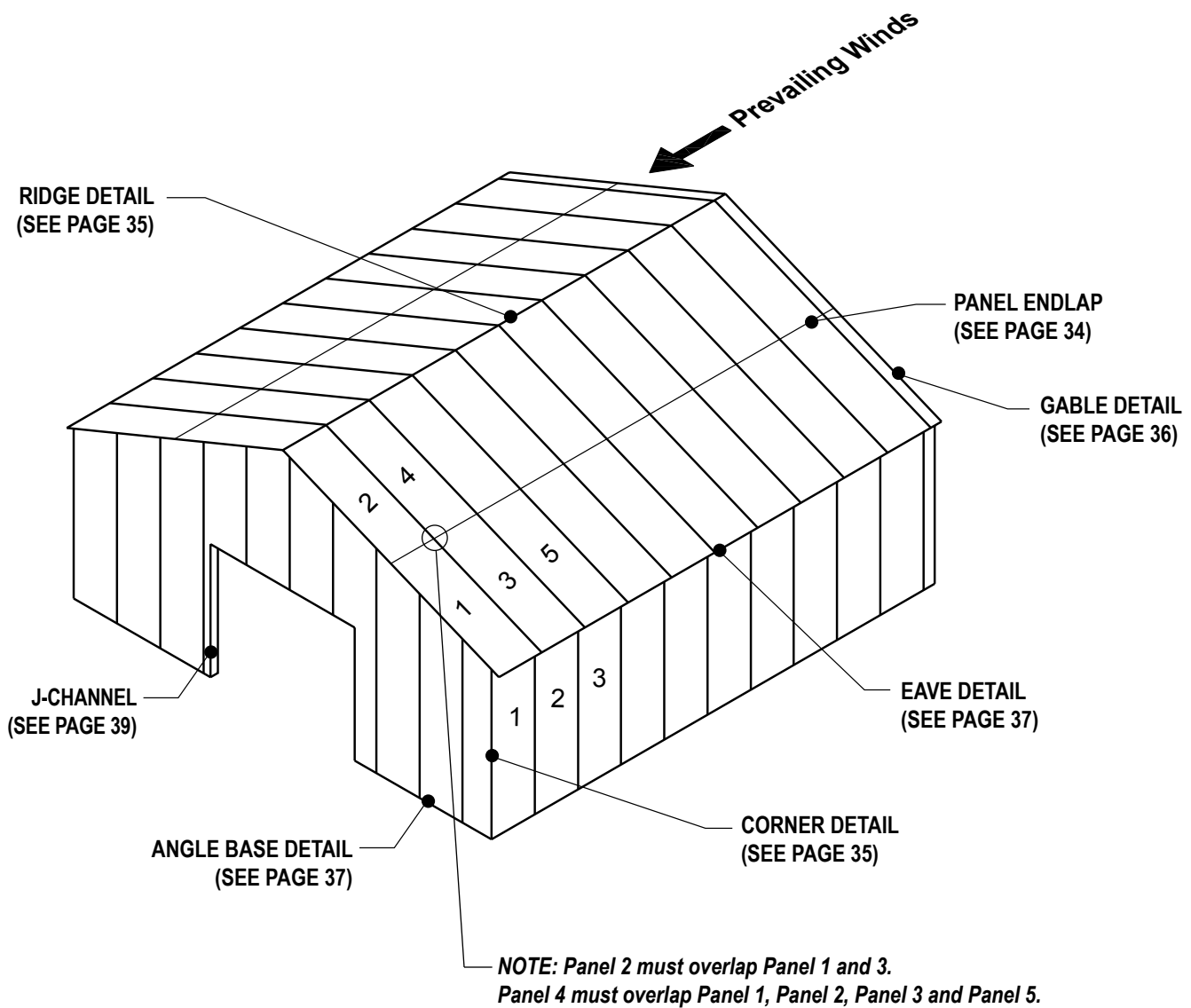



**NOTE:** -Eave Molding and Valley Flashings must first be installed before panel installation can begin.  
-Panels can be installed going from either left to right or right to left / looking from eave to highside.

## INSTALLING INSIDE CLOSURES

### STEP 1

1. Apply a row of Tape Sealant across the top leg of the Eave Molding along the width of the building.
2. Align and place Inside Closures over the Tape Sealant. It is critical that Inside Closures are square to building as this will control the alignment of the panels. (See page 29 to check building square).
3. Apply a row of Tape Sealant across the top of the Inside Closure (Not shown for clarity).

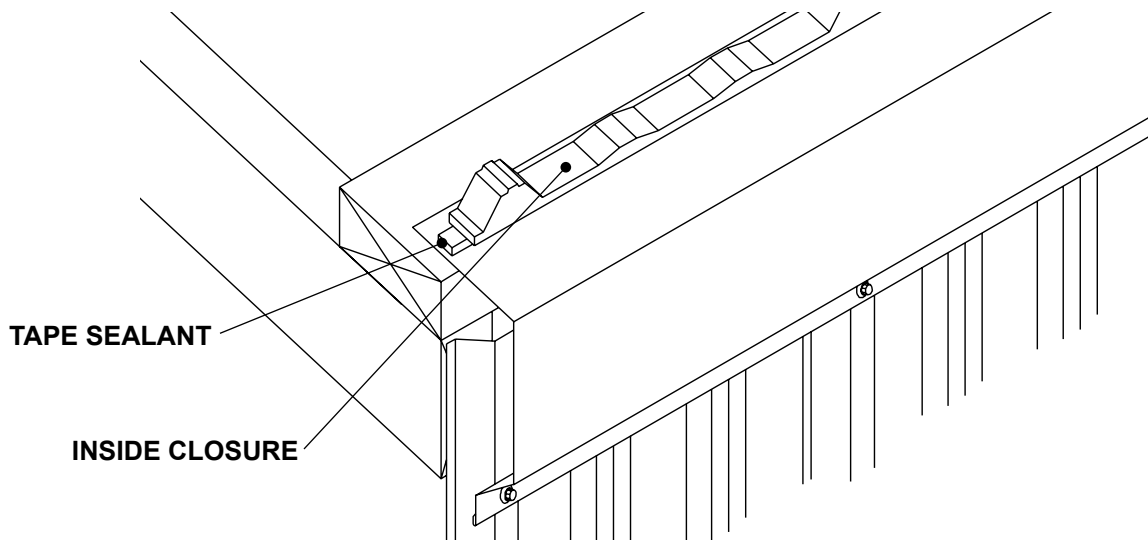

## INSTALLING FIRST PANEL

### STEP 2

1. Install the first panel over the Inside Closure allowing desired overhang. Make sure the panel is square to the eave and rake.
2. Fasten through panel, closure and sealants into decking with appropriate amount of fasteners to meet local building code. (See fastening patterns on pages 7, 9, 11, 13, 15 or 19). Fasteners must penetrate closure and sealant.
3. After securing panel at eave, repeat the fastening pattern at all panel support locations.

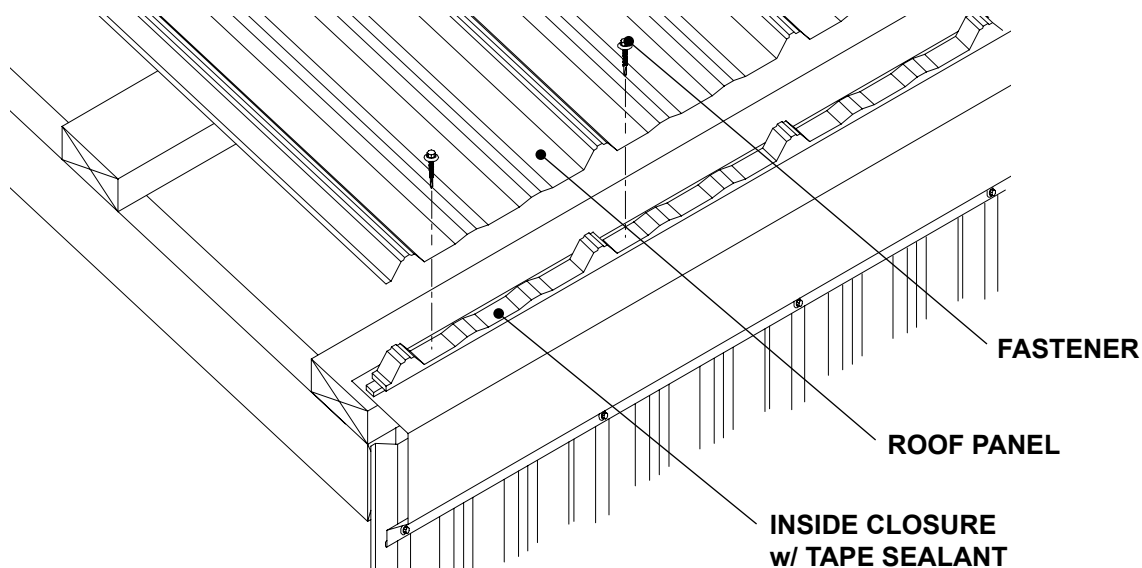

**INSTALLING ENDLAP PANEL (IF REQUIRED)**

**STEP 3**

1. Apply a row of Tape Sealant across and over the ribs of the eave panel about 3" from panel end.
2. Install the ridge panel over the eave panel and Tape Sealant with a 6" Endlap. Fasten through both panels and Tape Sealant into support with appropriate amount of fasteners to meet local building code. (See fastening patterns on pages 7, 9, 11, 13, 15 or 19). Fasteners must penetrate sealant.
3. After securing panel, repeat the fastening pattern at all panel support locations.

**Note: when endlapping multiple panels: at the side laps, both the ridge panels must overlap both eave panels.**

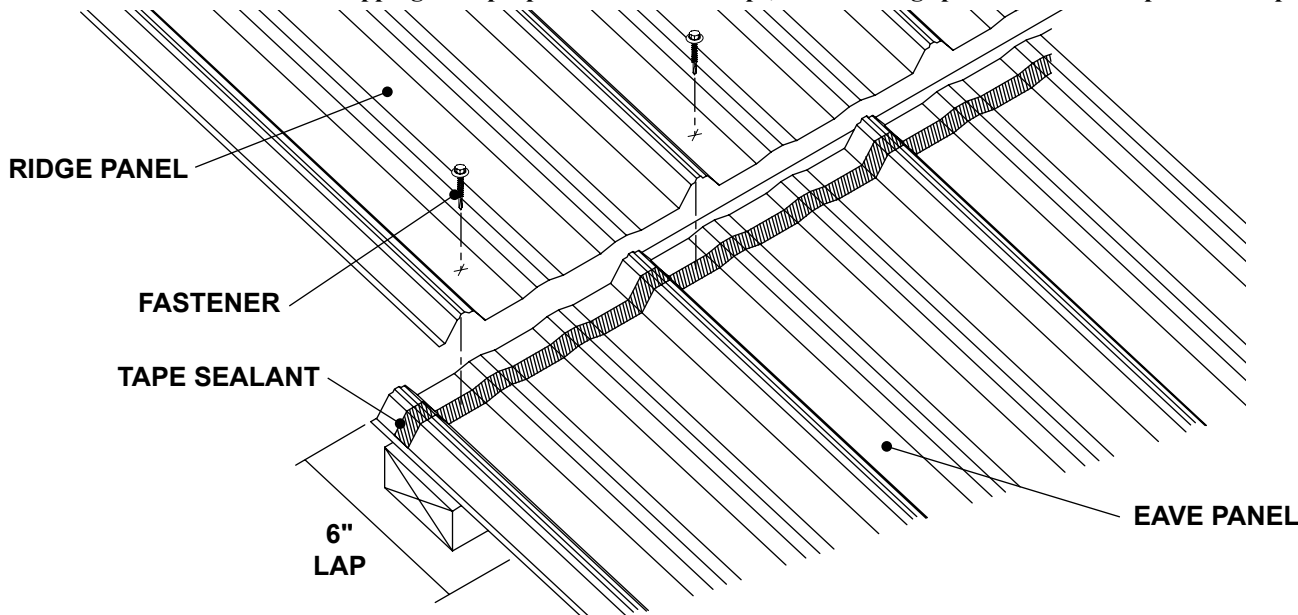

**INSTALLING SIDELAP PANEL**

**STEP 4**

1. Place the lapping seam of the second panel on top of previously installed panel so that panel ends are flush at eave (See below).
2. Fasten through panel, closure, and Tape Sealant into support with appropriate amount of fasteners to meet local building code. (See fastening patterns on pages 7, 9, 11, 13, 15 or 19). Fasteners must penetrate closure and sealant.
3. After securing panel, repeat the fastening pattern at all panel support locations.

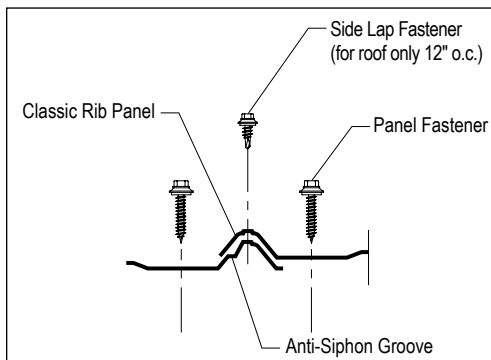
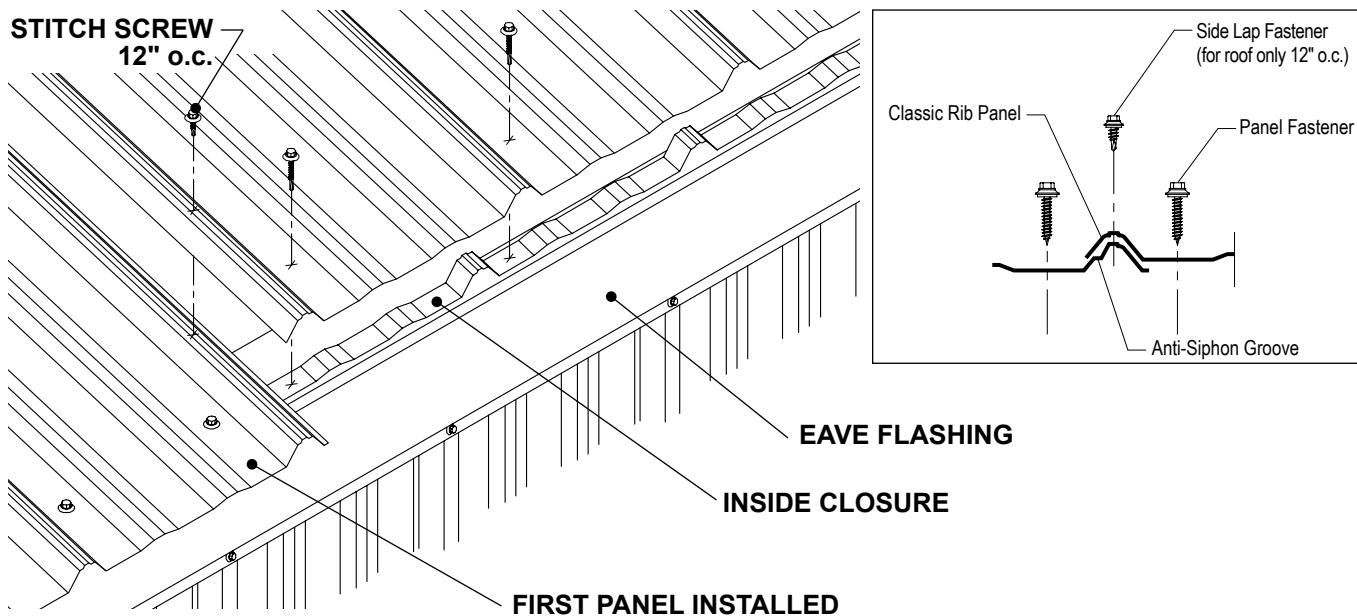

**14" UNIVERSAL RIDGE DETAIL**

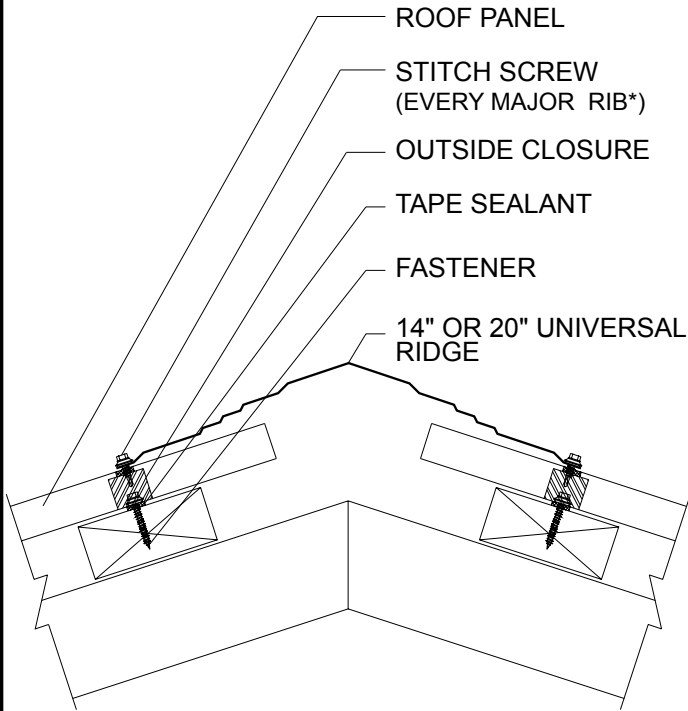

\* Fastener to be 8"-12" O.C. depending on panel profile.

**LOW PROFILE RIDGE VENT DETAIL**

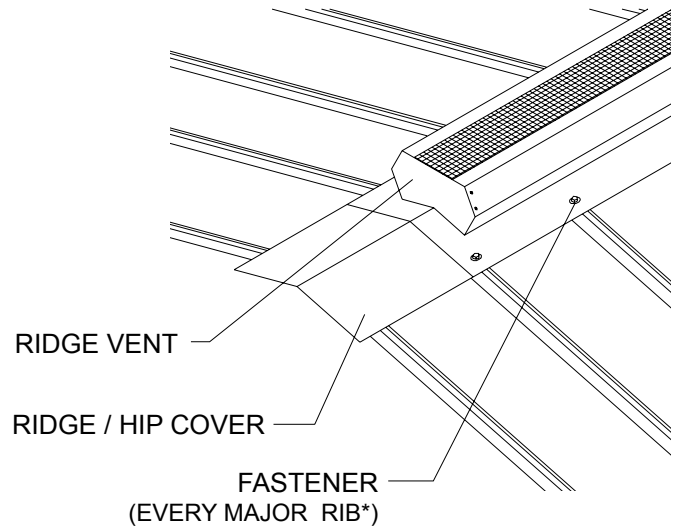

\* Fastener to be 8"-12" O.C. depending on panel profile.

**OUTSIDE CORNER DETAIL**

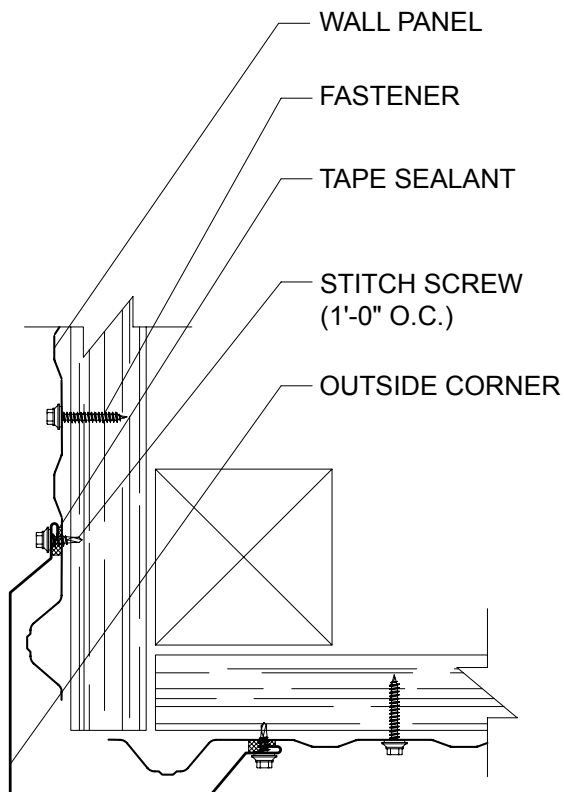

**INSIDE CORNER DETAIL**

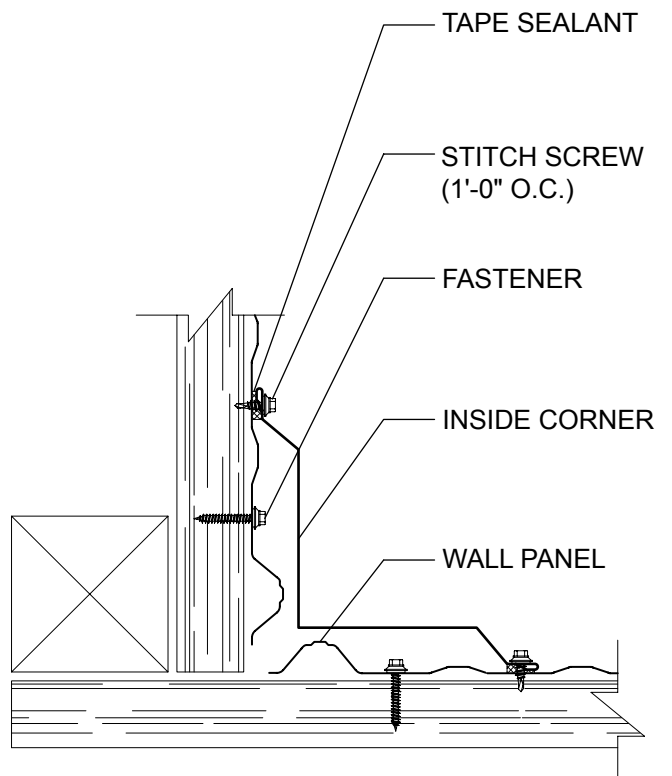

**GABLE TRIM DETAIL**

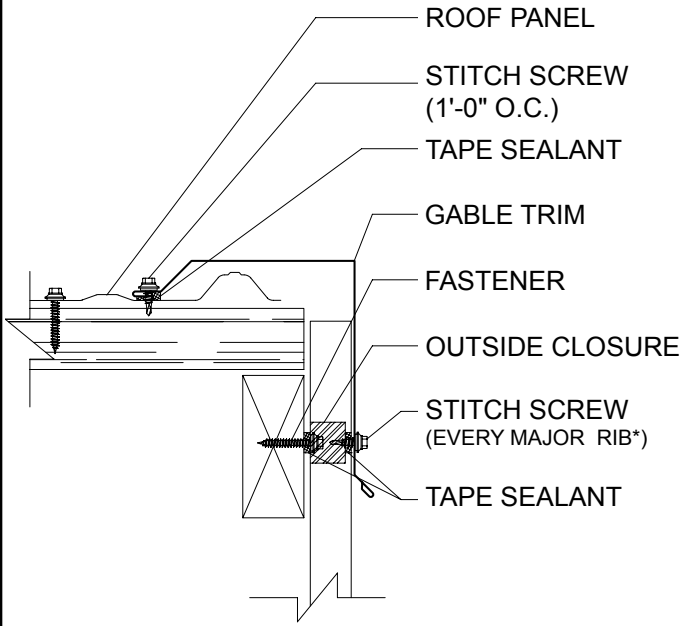

\* Fastener to be 8"-12" O.C. depending on panel profile.

**RAKE TRIM DETAIL**

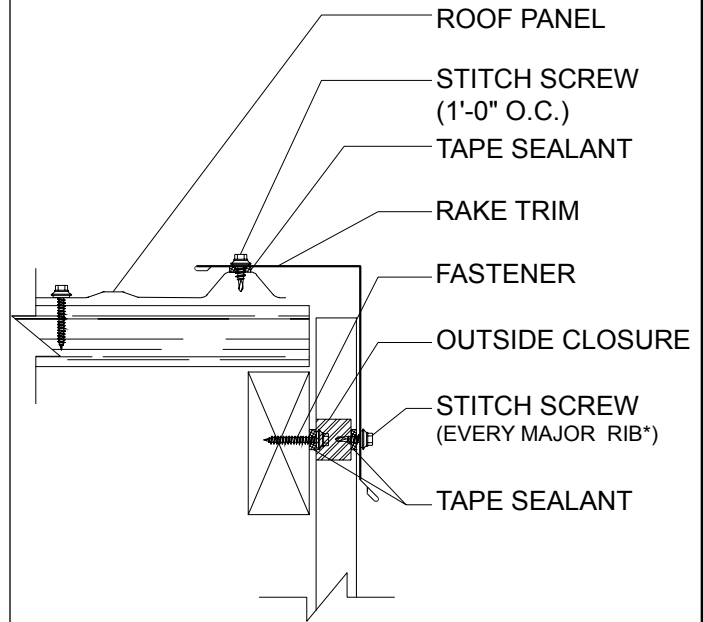

\* Fastener to be 8"-12" O.C. depending on panel profile.

**UNIVERSAL SIDEWALL DETAIL**

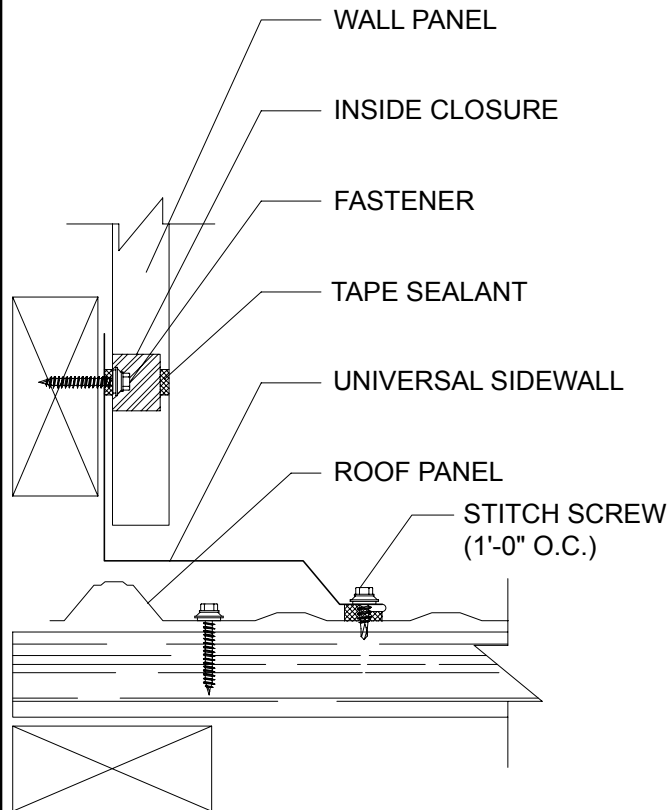

**UNIVERSAL ENDWALL DETAIL**

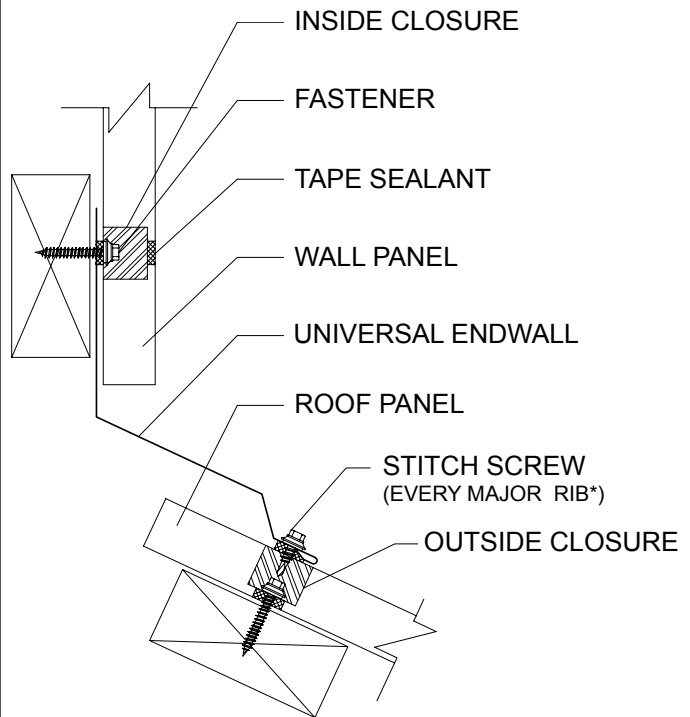

\* Fastener to be 8"-12" O.C. depending on panel profile.

**EAVE MOLDING DETAIL**

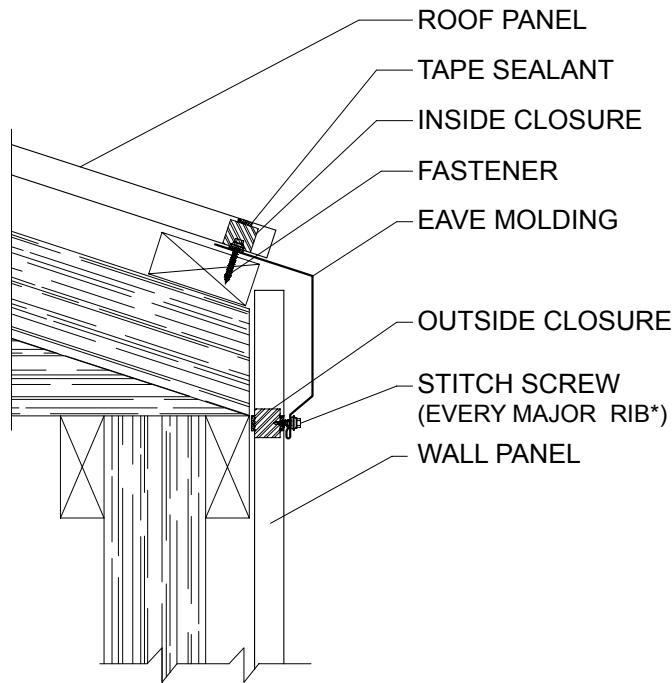

\* Fastener to be 8"-12" O.C. depending on panel profile.

**UNIVERSAL GAMBREL DETAIL**

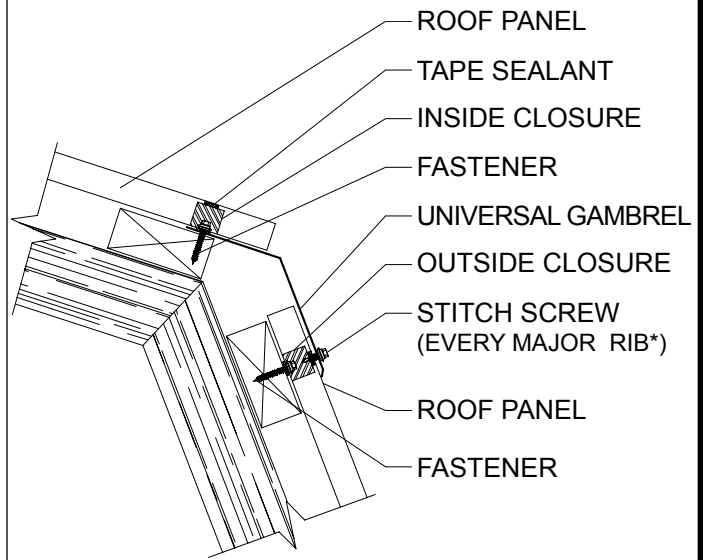

\* Fastener to be 8"-12" O.C. depending on panel profile.

**ANGLE BASE DETAIL**

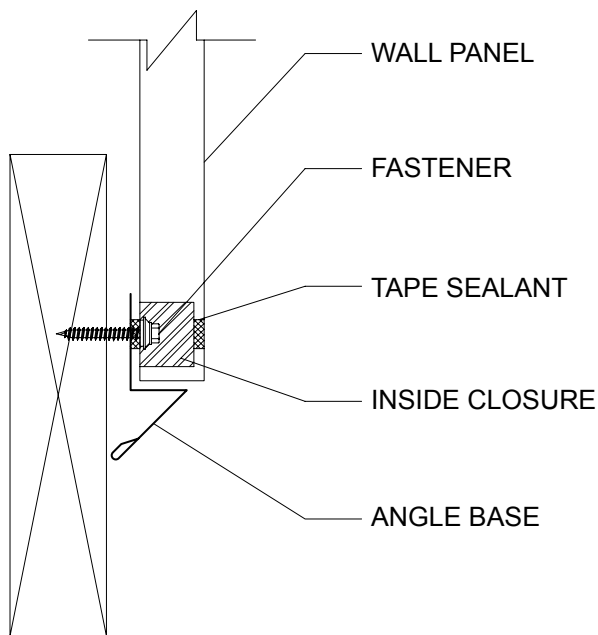

**DOUBLE ANGLE DETAIL**

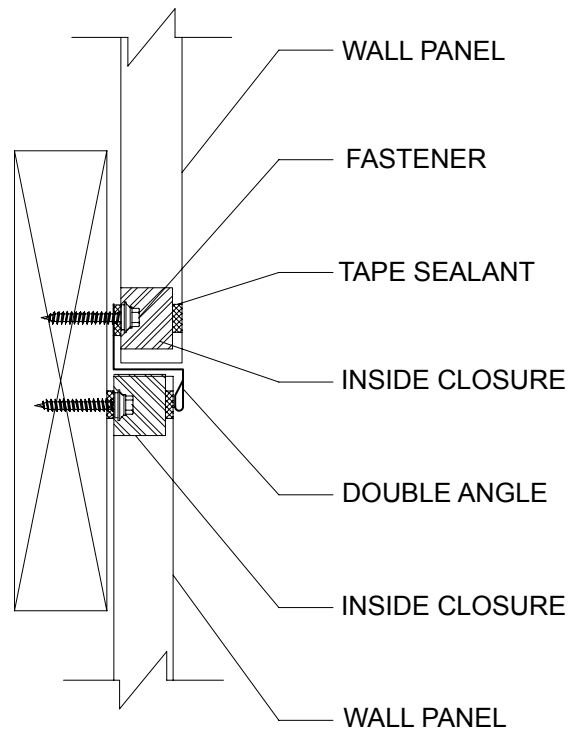

**DRIP CAP DETAIL**

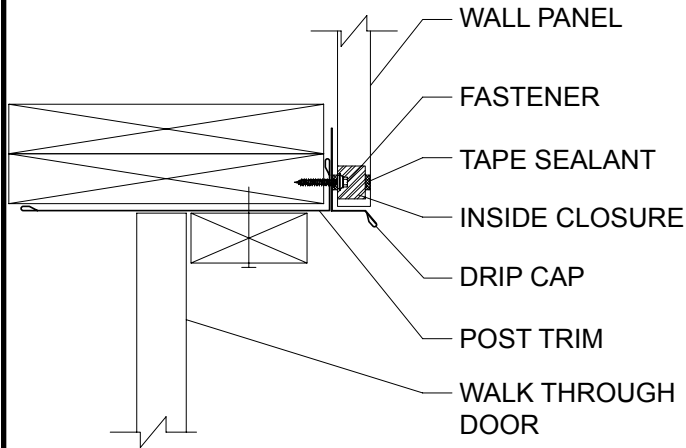

**BASE MOLDING DETAIL**

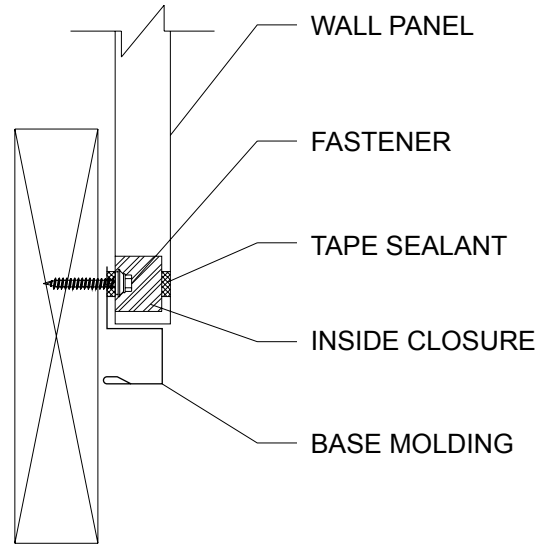

**CANNONBALL TRACK COVER DETAIL**

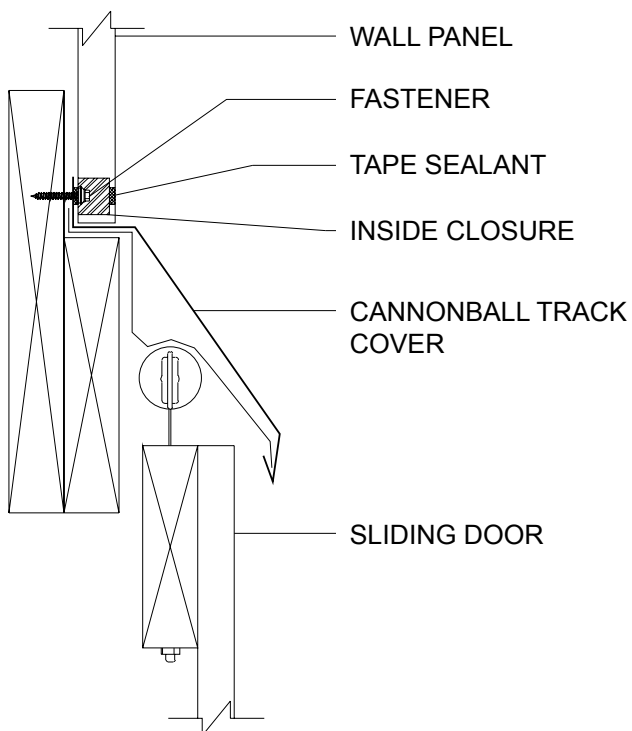

**NATIONAL TRACK COVER DETAIL**

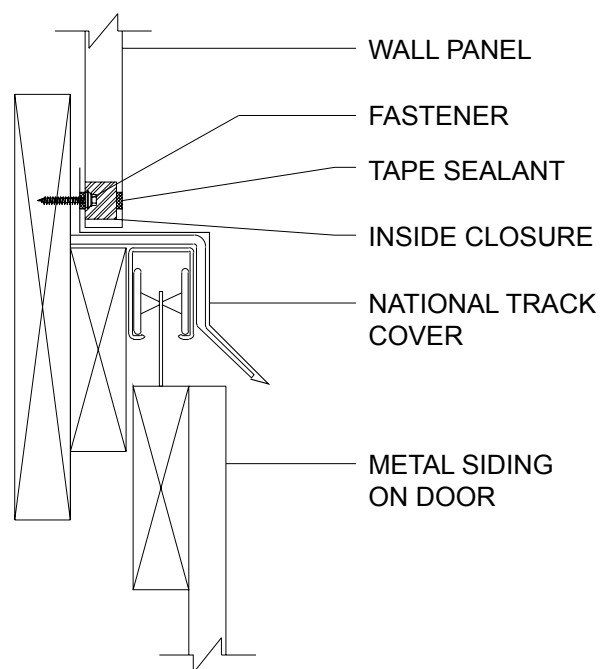

DOOR JAMB DETAIL

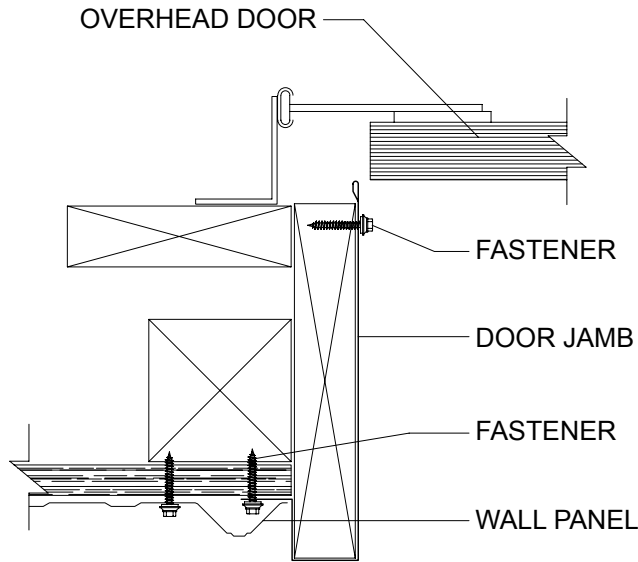

MINI-ANGLE / U-FLASHING DETAIL

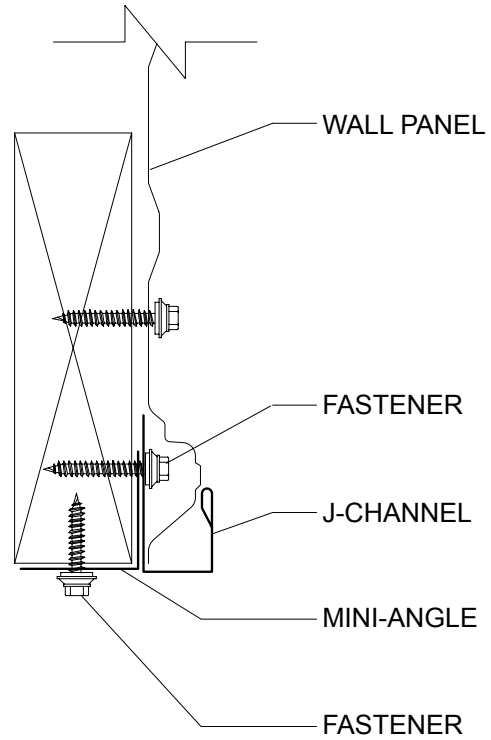

POST TRIM DETAIL

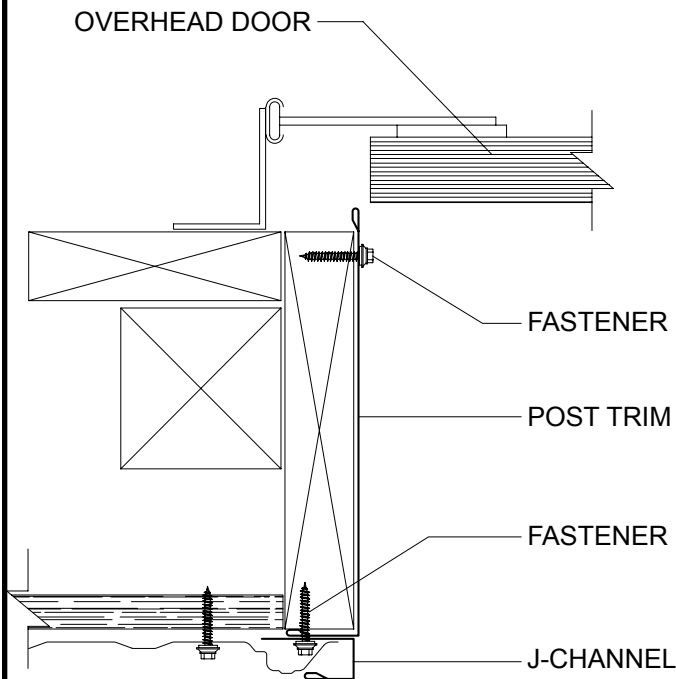

DOOR POST TRIM DETAIL

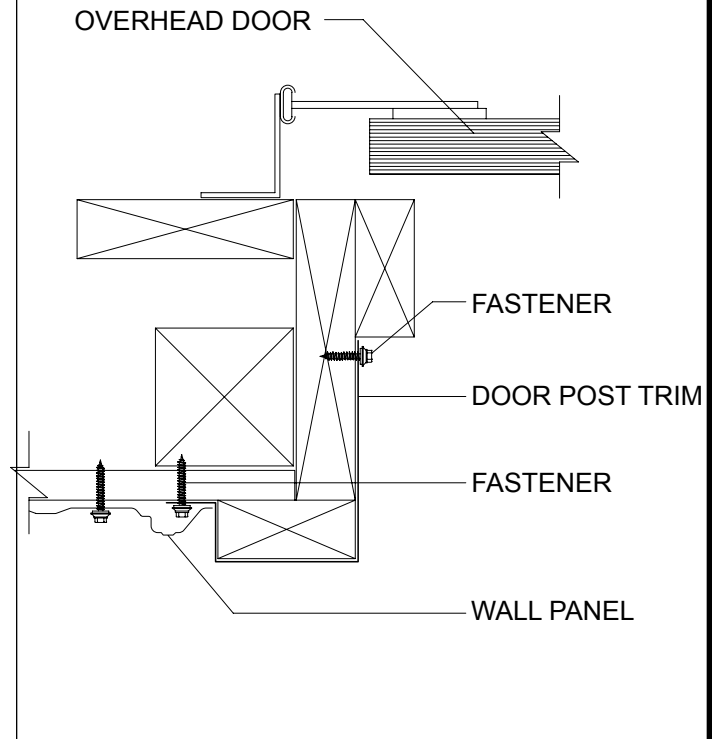

**OVERHEAD DOOR TRIM DETAIL**

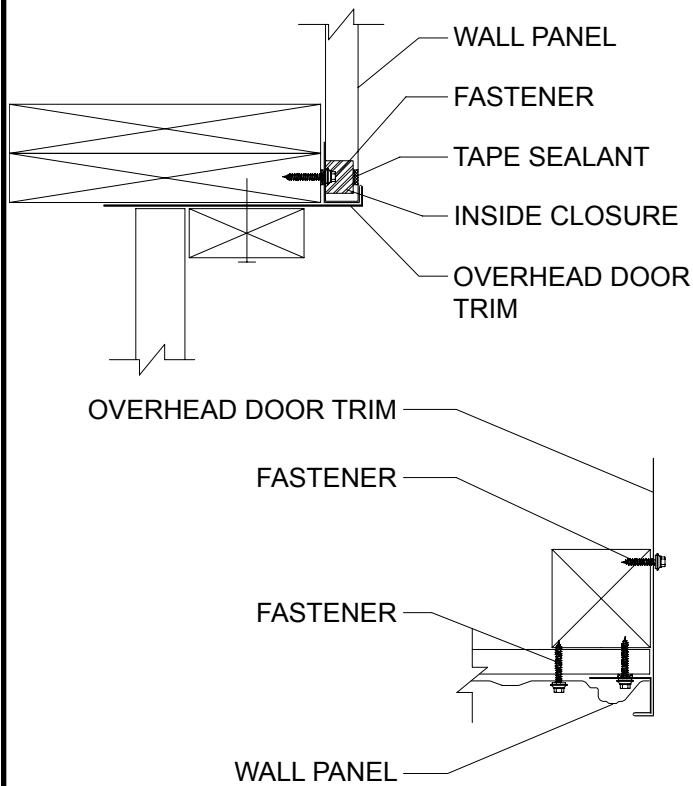

**SOFFIT DETAIL**

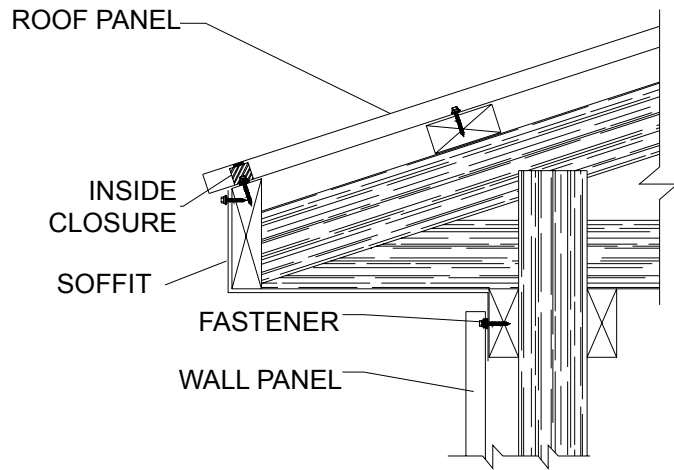

**12" SOFFIT DETAIL**

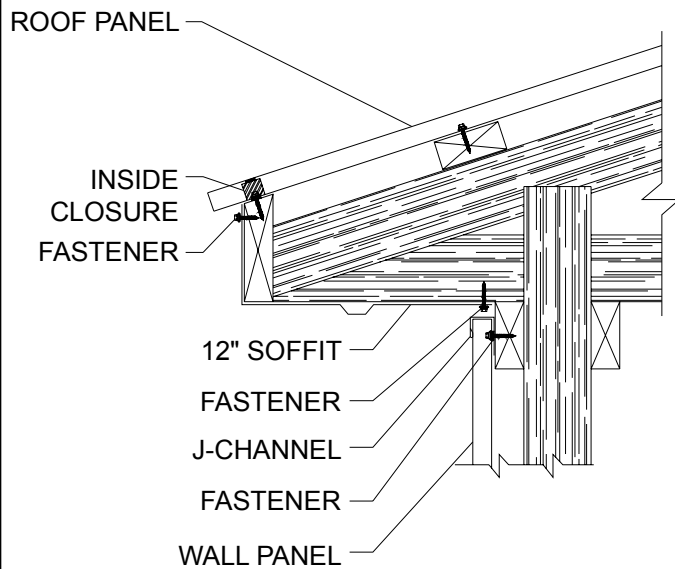

**24" SOFFIT DETAIL**

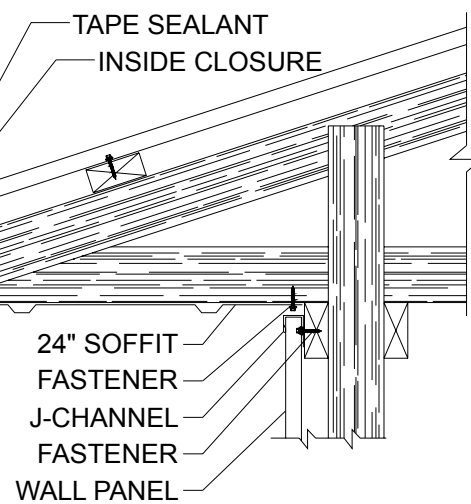



## INSTALLATION OVERVIEW

- ▶ As shown below with the number designations, install panel against the prevailing wind.
- ▶ Make sure panels are square and plumb, to assure straight and proper alignment of the entire row of panels.
- ▶ For areas with high wind considerations, closer fastener spacing may be required.
- ▶ It is necessary to attach a temporary guide to the foundation to use as an alignment guide when installing siding panels.
- ▶ Anti-Siphon groove side of panel must be overlapped with the non-siphon groove side of the adjacent panel (if applicable).

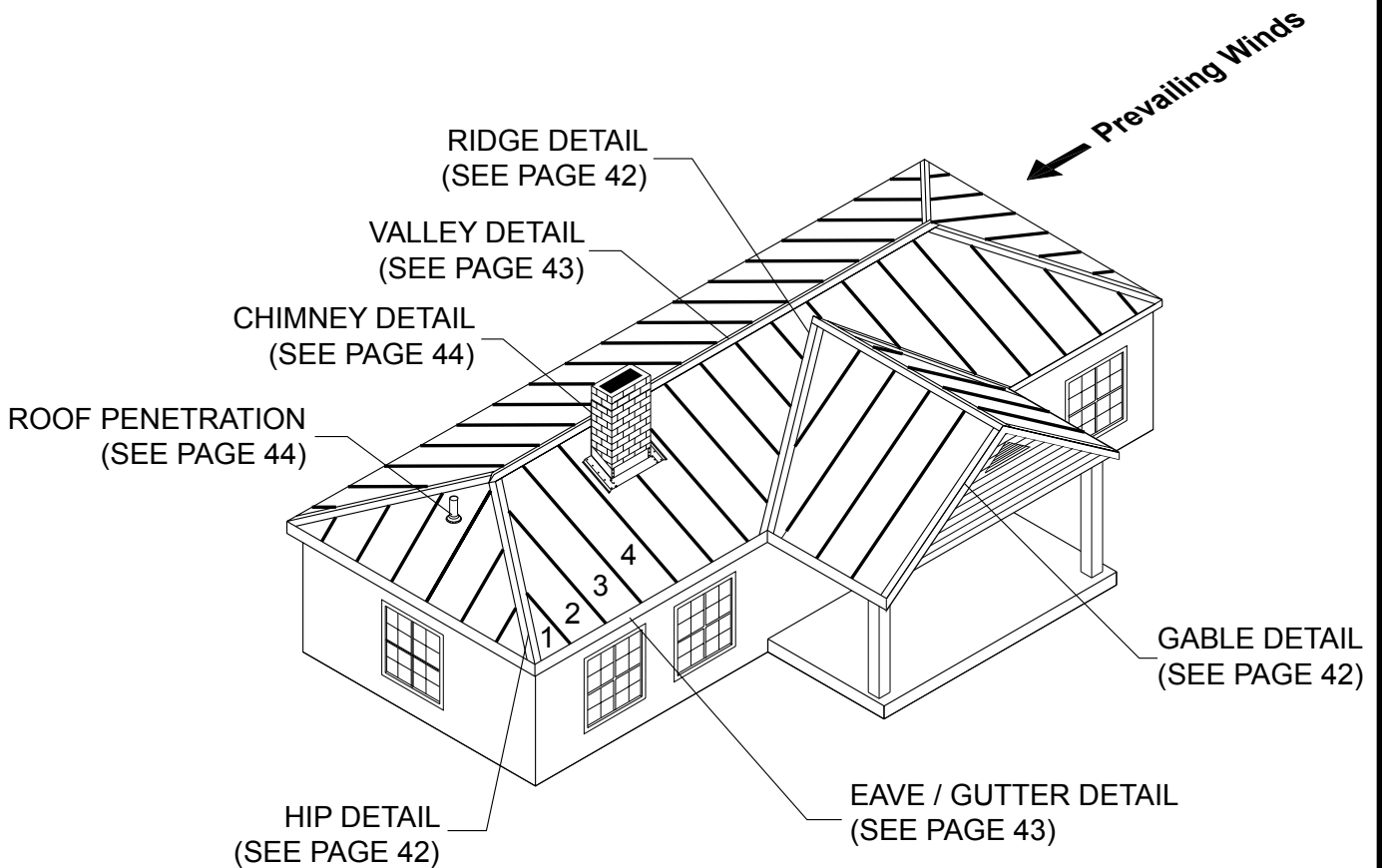

**NOTE:** -Eave Molding, Gutter and Valley Flashings must first be installed before panel installation can begin.  
-Panels can be installed going from either left to right or right to left / looking from eave to peak.

## INSTALLING INSIDE CLOSURES

### STEP 1

1. Apply a row of Tape Sealant across the top leg of the Eave Molding along the width of the building.
2. Align and place Inside Closures over the Tape Sealant. It is critical that Inside Closures are square to building as this will control the alignment of the panels. (See page 29 to check building square).
3. Apply a row of Tape Sealant across the top of the Inside Closure (not shown for clarity).

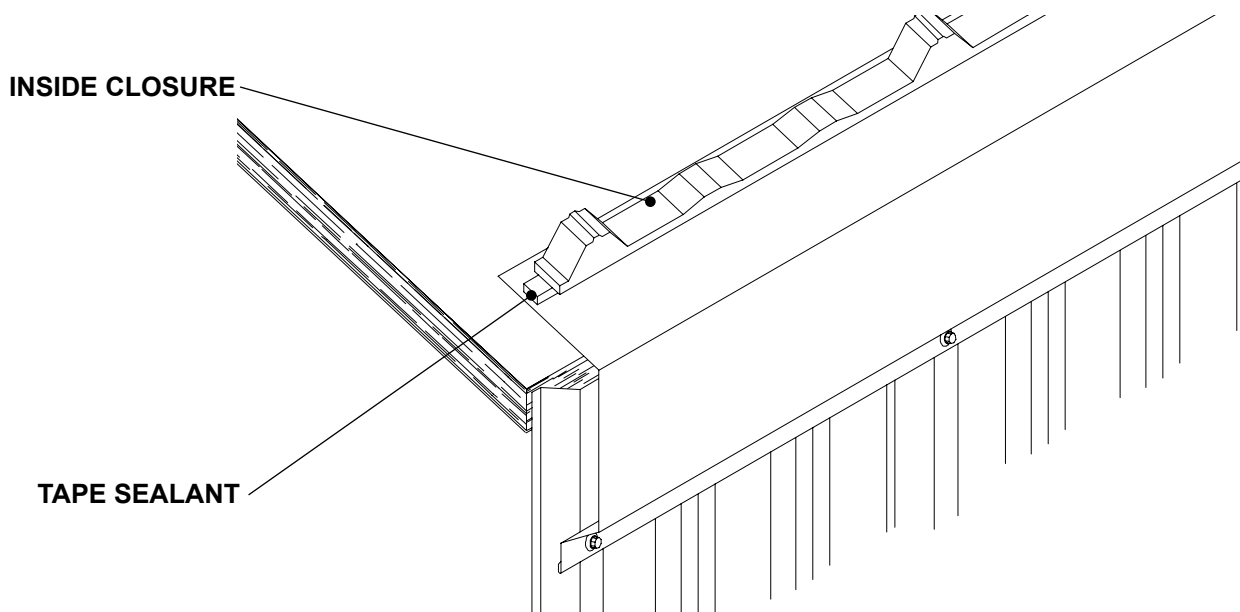

## INSTALLING FIRST PANEL

### STEP 2

1. Install the first panel over the Inside Closure to allow for desired overhang. Make sure the panel is square to the eave and rake.
2. Fasten through panel, closure and sealants into decking with appropriate amount of fasteners to meet local building code. (See fastening patterns on pages 7, 9, 11, 13, 15 or 19). Fasteners must penetrate closure and sealant.
3. After securing panel at eave, repeat the fastening pattern at the appropriate spacing to meet local building codes.

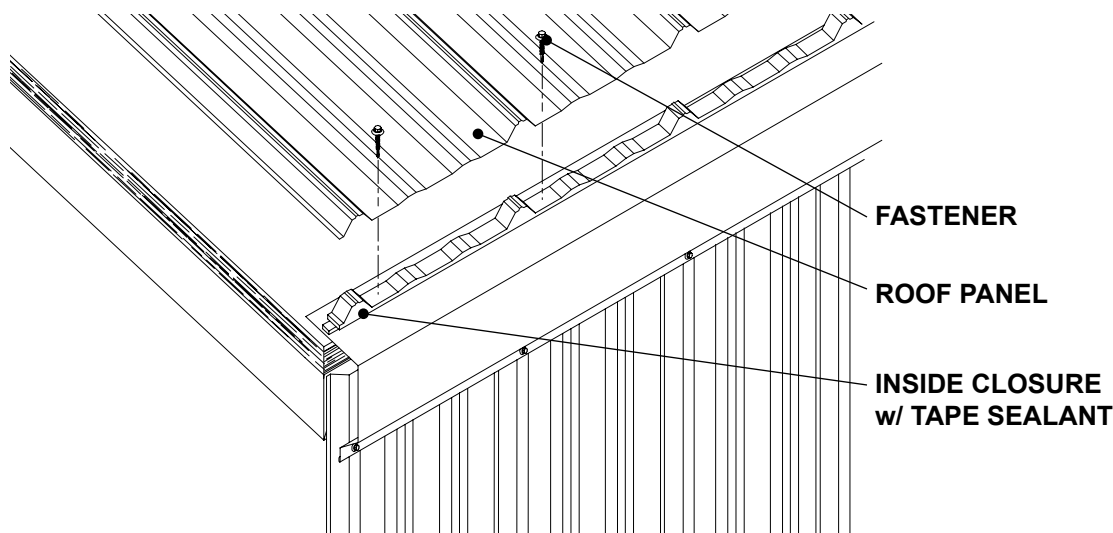

**INSTALLING SECOND PANEL**

**STEP 3**

1. Apply a row of Tape Sealant across and over the ribs of the first panel about 3" from panel end.
2. Install the second panel over the first panel and Tape Sealant with a 6" Endlap. Fasten through both panels and Tape Sealant into support with appropriate amount of fasteners to meet local building code. (See fastening patterns on pages 7, 9, 11, 13, 15 or 19). Fasteners must penetrate sealant.
3. After securing panel at eave, repeat the fastening pattern at the appropriate spacing to meet local building codes.

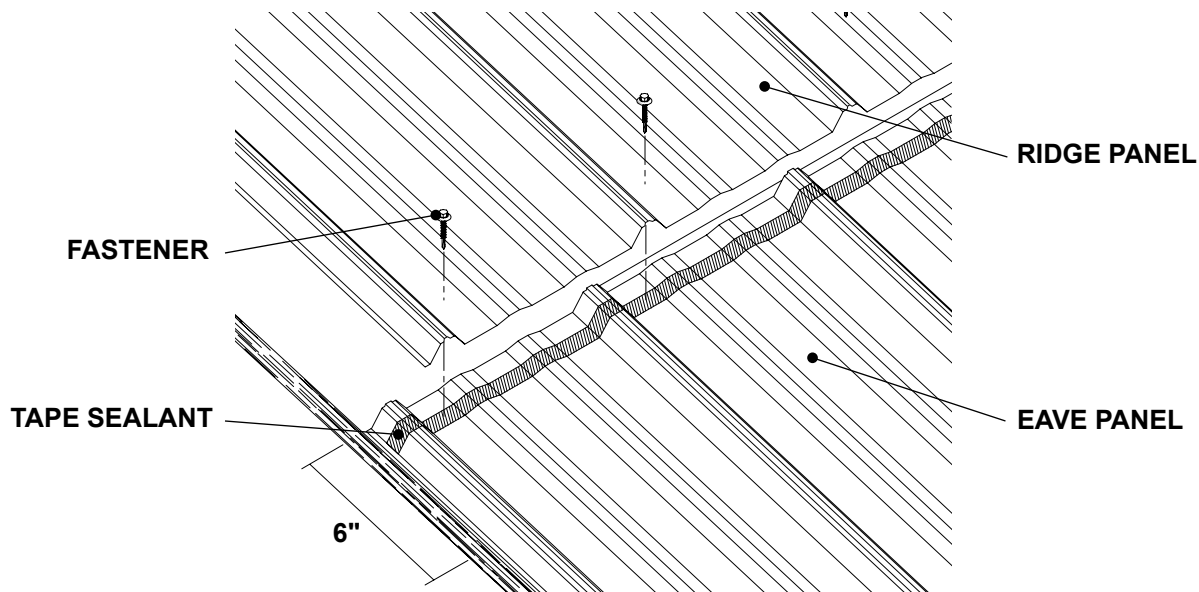

**INSTALLING SECOND EAVE PANEL**

**STEP 4**

1. Place the lapping seam of the second panel on top of previously installed panel so that panel ends are flush at eave (See below).
2. Fasten through panel, closure and Tape Sealant into support with appropriate amount of fasteners to meet local building code. (See fastening patterns on pages 7, 9, 11, 13, 15 or 19). Fasteners must penetrate closure and sealant.
3. After securing panel at eave, repeat the fastening pattern at the appropriate spacing to meet local building codes.

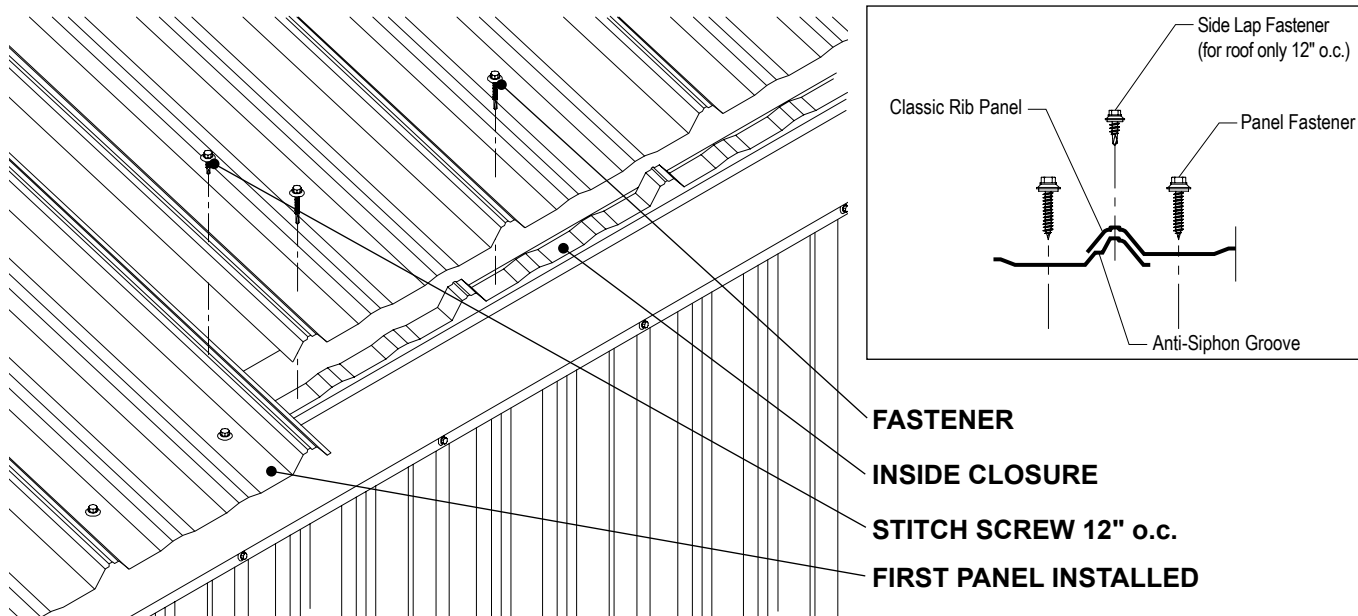

**14" UNIVERSAL RIDGE DETAIL**

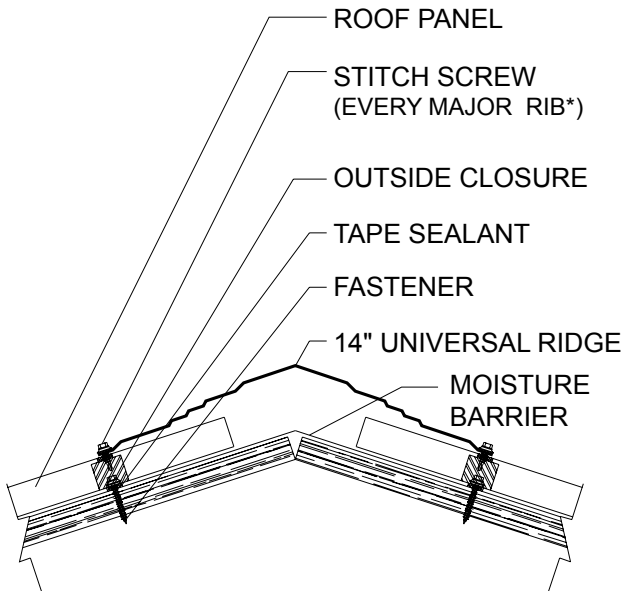

\* Fastener to be 8"-12" O.C. depending on panel profile.

**RIDGE / HIP COVER DETAIL**

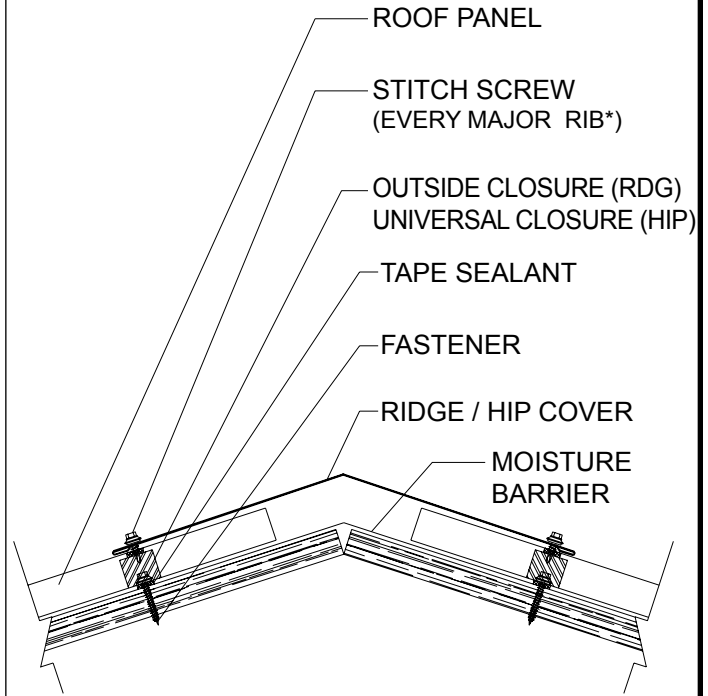

\* Fastener to be 8"-12" O.C. depending on panel profile.

**VENTED RIDGE DETAIL**

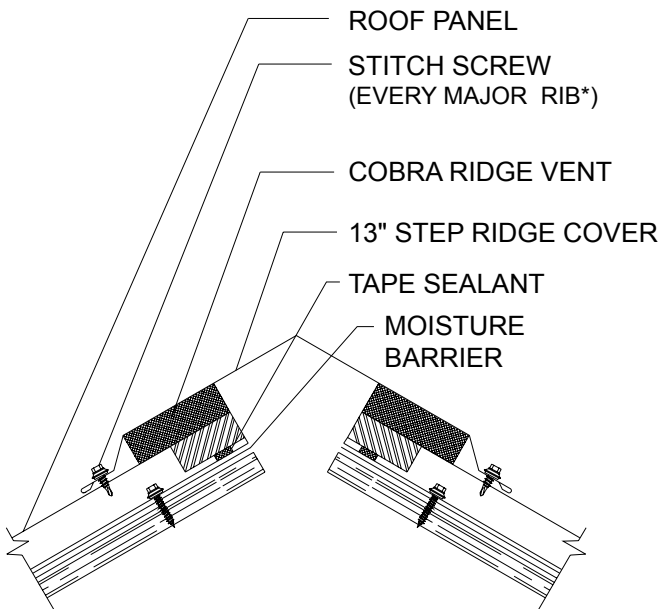

\* Fastener to be 8"-12" O.C. depending on panel profile.

**GABLE TRIM DETAIL**

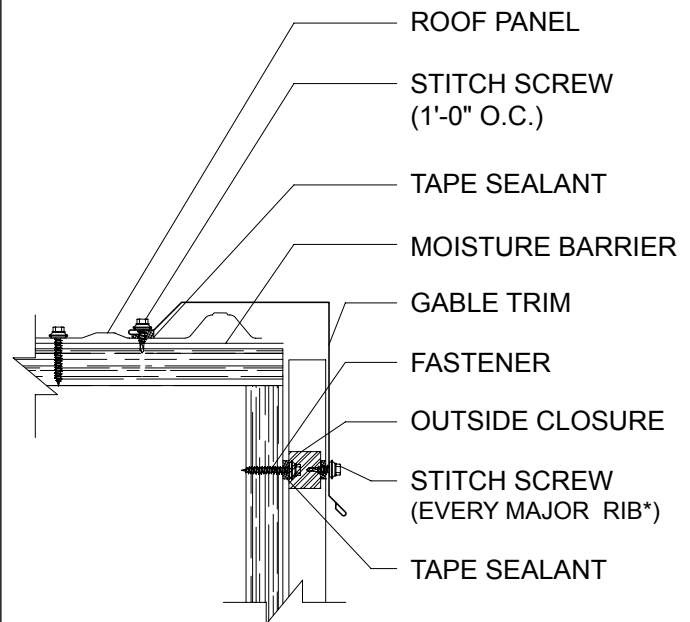

\* Fastener to be 8"-12" O.C. depending on panel profile.

**EAVE DETAIL**

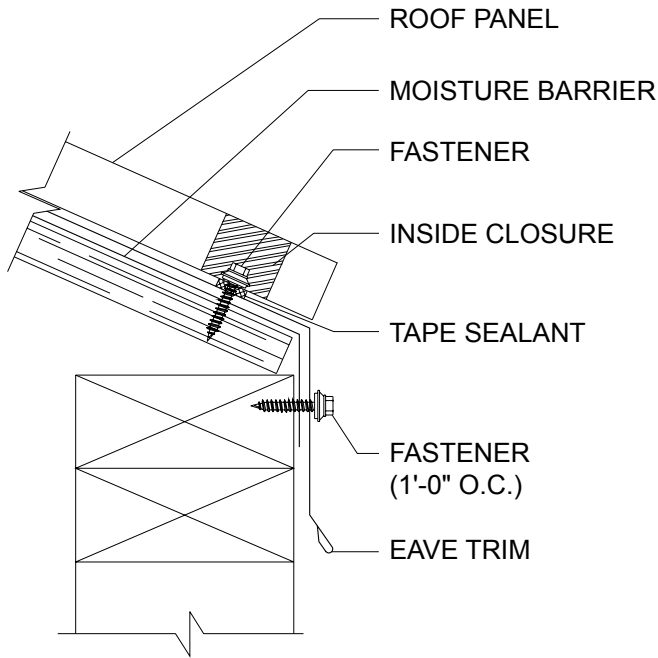

**GUTTER DETAIL**

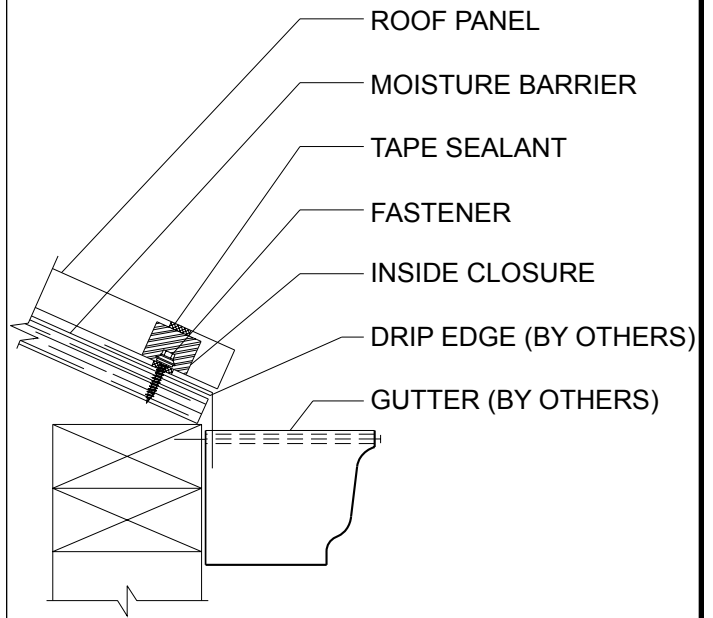

**VALLEY DETAIL**

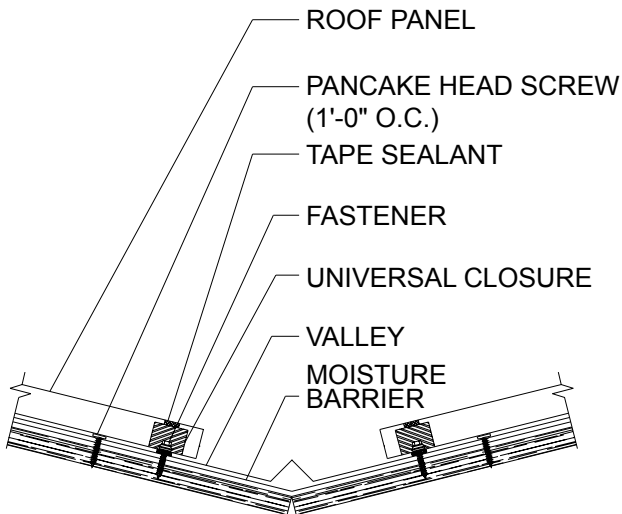

**PITCH BREAK DETAIL**

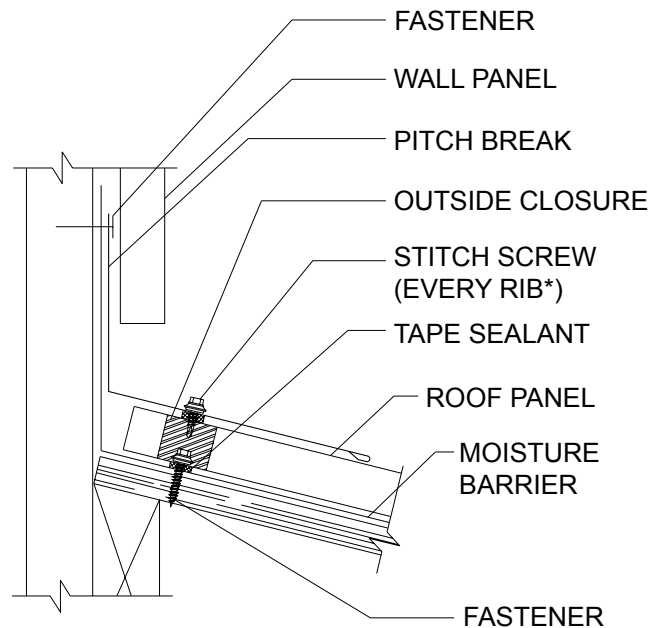

\* Fastener to be 8"-12" O.C. depending on panel profile.

**CHIMNEY / CRICKET DETAIL**

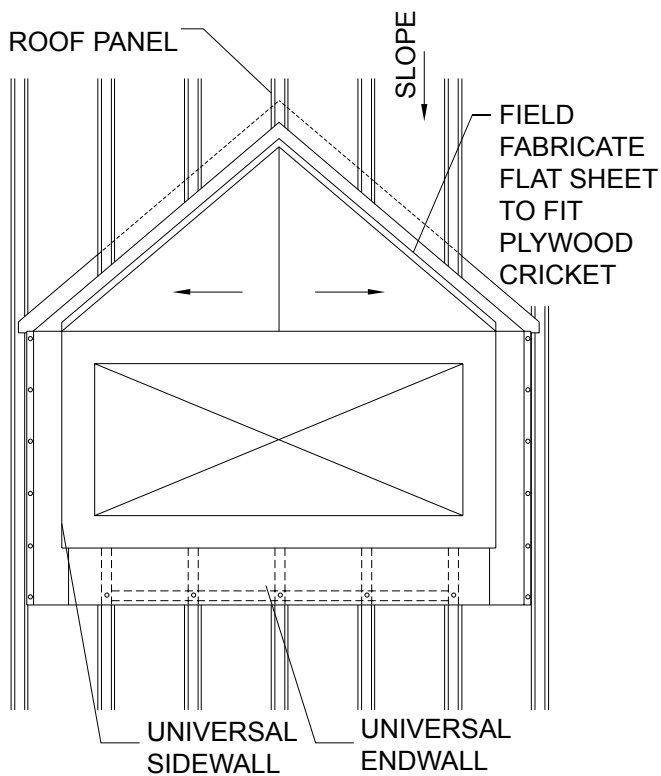
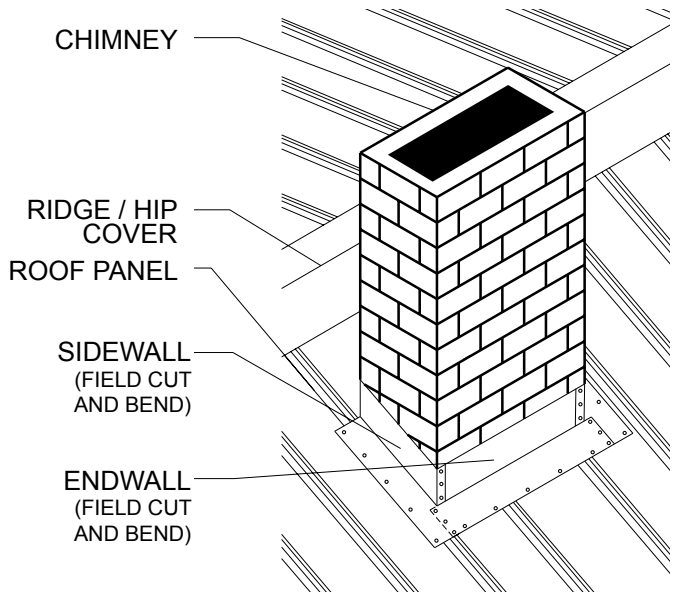

**ROOF PENETRATION DETAIL**

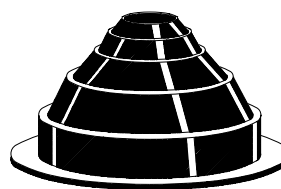
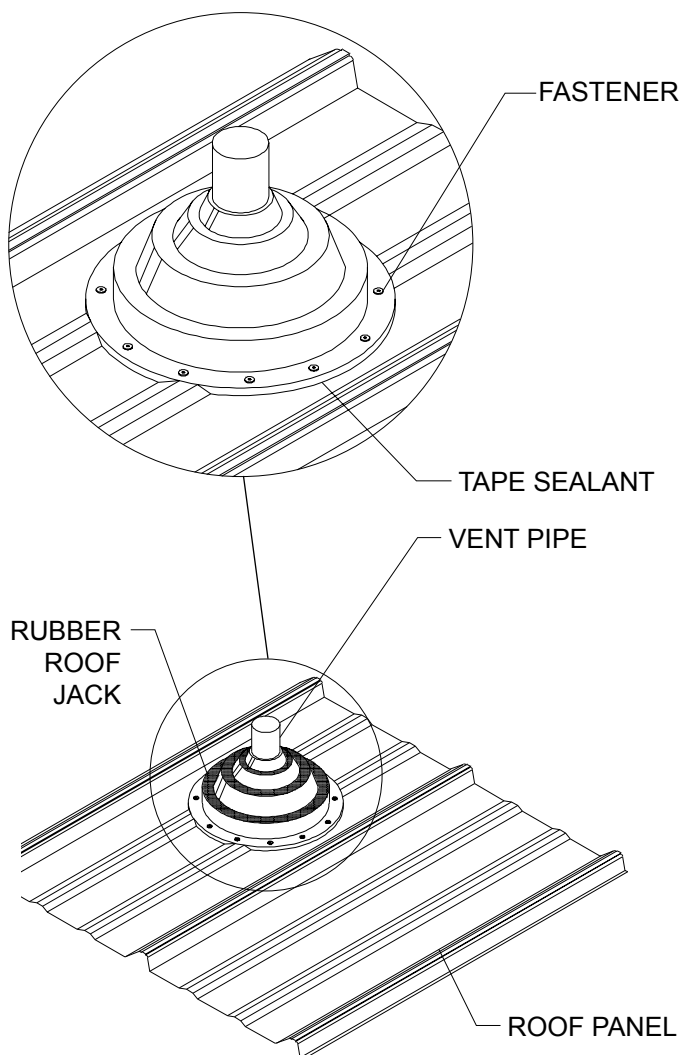

**AVAILABLE SIZES**

- MINI (1/4" TO 1 1/8" O.D. PIPE)
- #2 (1 3/4" TO 3" O.D. PIPE)
- #4 (3" TO 6" O.D. PIPE)
- #6 (6" TO 9" O.D. PIPE)
- #8 (7" TO 13" O.D. PIPE)

Though factory applied prepainted finishes are very durable and will last many years, eventually it may be desirable to thoroughly clean or repaint them.

Dirt pickup may cause apparent discoloration of the paint when it has been exposed in some dirt-laden environments for long periods of time. In areas of strong sunlight, slight chalking may cause some change in appearance. A good cleaning will often restore the appearance of these buildings and render repainting unnecessary. An occasional light cleaning will help maintain a good appearance.

In many cases, simply washing the building with plain water using a hose or pressure sprayer will be adequate. In areas where heavy dirt deposits dull the surface, a cloth or soft bristle brush and solution of water and detergent ( $\frac{1}{3}$  cup of laundry detergent per gallon of water for example) may be used. This should be followed by an adequate rinse of water. Do not use wire brushes, abrasives, or cleaning tools which will damage the coating surface.

Mildew may occur in areas subject to high humidity but is not normally a problem due to the high inherent mildew resistance of the baked finish that is used. To remove mildew along with the dirt, the following solution is recommended.

- $\frac{1}{3}$  cup detergent (Tide® or equivalent)
- $\frac{2}{3}$  cup trisodium phosphate (Solex® or equivalent)
- 1 quart of 5% sodium hypochlorite solution (Clorox® or equivalent)
- 3 quarts of water

Strong solvents and abrasive type cleaners should be avoided. Most organic solvents are flammable and toxic and must be handled accordingly. When using a solvent, consult maintenance professionals and label instructions for proper handling and disposal of washings. If required, a mild solvent such as mineral spirits can be used to remove caulking compounds, oil, grease, tars, wax, and similar substances. Use a cloth dampened with mineral spirits and apply only to areas which are contaminated. Follow up the use of this mild solvent with detergent cleaning and rinsing.

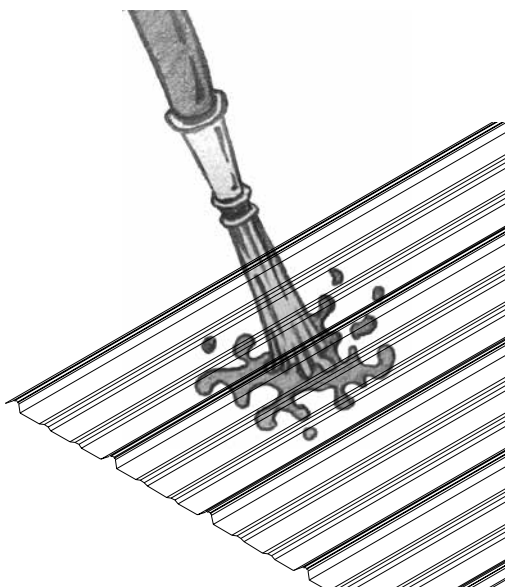

**HOSE OR PRESSURE SPRAY  
FOR ADEQUATE CLEANING**



**DO NOT USE A  
WIRE BRUSH**



**USE MILD DETERGENT AND WATER  
FOR HEAVY DIRT DEPOSITS**