

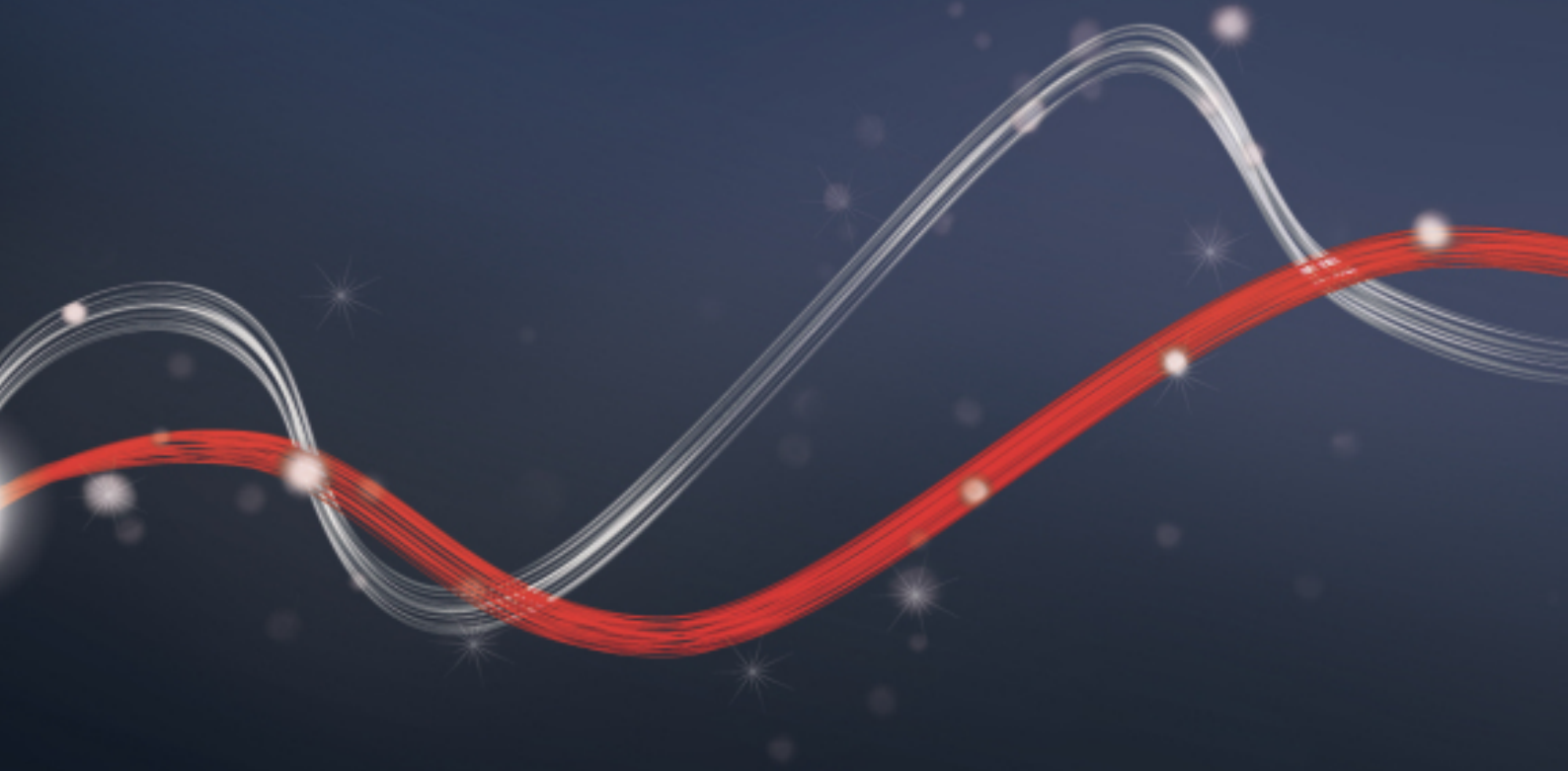

Be ahead



ICARO



Product

PLUS

CONTROL UNIT
TECHNICAL FEATURES

ACCESSORIES

DISCOVER U-LINK



230V slide gate operators for very intensive use, extremely sturdy and high-performance. The control unit ensures complete safety thanks to the exclusive torque control system that makes these operators comply fully with the current European standards.

ICARO | | | | | |

Code	Name		Description	
P925182 00003	ICARO SQ PROX		Operator 230 V for sliding gates up to 2000 kg in weight. Leaf speed 9 m/min.	
P925225 00002	ICARO N F		Operator 230 V for sliding gates up to 2000 kg. Leaf speed 9 m/min. Limit switch Electromechanical. Equipped with mechanical safety clutch.	
P925226 00002	ICARO N F V		Operator 230 V for sliding gates up to 1000 kg. Leaf speed 12 m/min. Limit switch electromechanical. Equipped with mechanical safety clutch.	
P925228 00002	ICARO N F PROX		Operator 230 V for sliding gates up to 2000 kg. Leaf speed 9 m/min. Limit switch Inductive. Equipped with mechanical safety clutch.	
P925227 00002	ICARO N F SQ 230		Operator 230 V for sliding gates up to 2000 kg in weight. Leaf speed 9 m/min.	
P925227 00003	ICARO N F V SQ 230		Operator 230 V for sliding gates up to 1000 kg in weight. Leaf speed 12 m/min.	
P925229 00002	ICARO N F PROX SQ 230		Operator 230 V for sliding gates up to 2000 kg in weight. Leaf speed 9 m/min.	
P925225 00001	ICARO N F 120		Operator 120 V for sliding gates up to 2000 kg in weight. Leaf speed 9 m/min.	
P925226 00001	ICARO N F V 120		Operator 120 V for sliding gates up to 1000 kg in weight. Leaf speed 12 m/min.	
P925227 00001	ICARO N F SQ 120		Operator 120 V for sliding gates up to 2000 kg in weight. Leaf speed 9 m/min.	
P925212 00002	ICARO N V		Operator 230 V for sliding gates up to 1000 kg in weight. Leaf speed 12 m/min.	

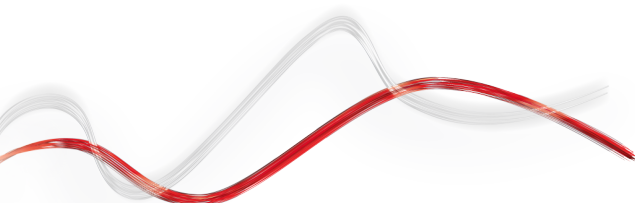

• Product

• PLUS

• CONTROL UNIT
• TECHNICAL FEATURES

• ACCESSORIES

• DISCOVER U-LINK

ICARO |



Code	Name	Description
P925211 00002	ICARO N	Operator 230 V for sliding gates up to 2000 kg in weight. Leaf speed 9 m/min.
P925213 00002	ICARO N PROX	Operator 230 V for sliding gates up to 2000 kg in weight. Leaf speed 9 m/min.

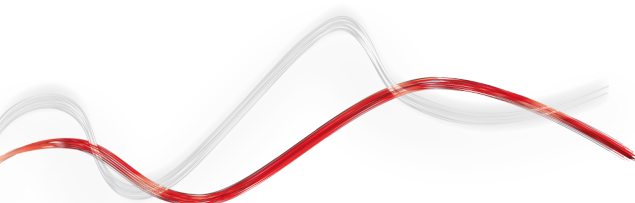

· Product

· **PLUS**

· CONTROL UNIT
· TECHNICAL FEATURES

· ACCESSORIES

· **DISCOVER U-LINK**

PLUS



Monoblock gear motor structure guaranteeing maximum resistance and performance in any installation conditions



Proximity limit switches for accurate, safe installations in any environmental conditions.



Control unit with programming display and D-Track torque, speed and position management and control system. Incorporated dual channel radio receiver

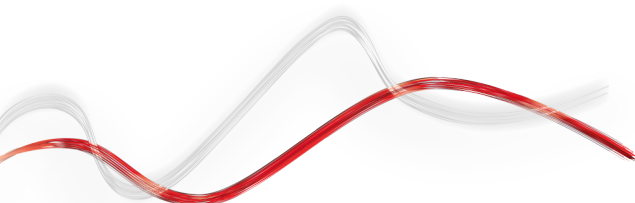

• Product

• PLUS

• **CONTROL UNIT**
• **TECHNICAL FEATURES**

• ACCESSORIES

• **DISCOVER U-LINK**

LEO B CBB OPALEO_B_CBB Built-In

Incorporated control unit for one 230V operator for sliding gates



- Board power supply: 230V single-phase
- Operator power supply: 230V 750W
- Main features: removable terminal blocks with new standard colour-coding, simplified scenario-based programming with display, incorporated dual channel receiver, D-Track anti-crushing system, slowdown during opening and closing
- Main functions: automatic re-closing, fast closing, pedestrian opening
- Compatibility: LEO D MA

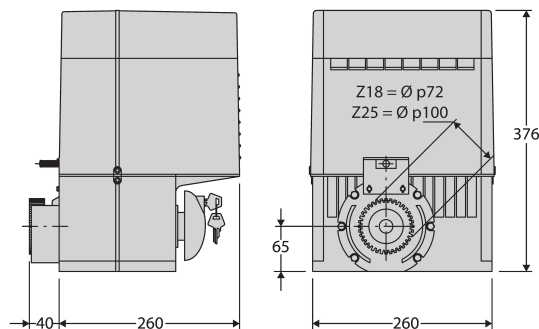

	ICARO SQ PROX	ICARO N F	ICARO N F V	ICARO N F PROX	ICARO N F SQ 230	ICARO N F V SQ 230	ICARO N F PROX SQ 230	ICARO N F 120	ICARO N F V 120	ICARO N F SQ 120	ICARO N V	ICARO N	ICARO N PROX
Control unit		LEO B CBB						LEO B CBB				LEO B CBB	
Power supply		230 V						120 V				230 V	
Power input		750 W											
Pinion module		4											
Slowdown		yes											
Locking		mechanical											
Release		knob operated with personal key											
Frequency of use		very-intensive											
Environmental conditions		from -15 °C to 60 °C											
Protection rating		IP24		IP55			IP24						
Actuator weight		25 kg											
Impact reaction		d-track		mechanical clutch			d-track	mechanical clutch		d-track			













• Product

• PLUS

• CONTROL UNIT
• TECHNICAL FEATURES

• **ACCESSORIES**

• DISCOVER U-LINK

	Code	Name	Description
	D221073	CP	Plastic rack, 4-module, cross-section 22 x 22 mm, length 1 m, screw-fitted into slots Portata massima 600 Kg.
	P111467	B EBA WIE DRIVER	Expansion card for connection of WIEGAND accessories, compatible with U-Link control units
	D571054	CFZ	Galvanized steel rack for welding, 22x22 mm, 4-module, cross-section from 2 m Portata massima 1000 kg.
	D571053	CVZ	Steel rack, 4-module, cross-section 30 x 12 mm, length 1 m, screw-fitted on supports (supplied) Portata massima 2000 Kg.
	N999320	CVZ-S	Steel rack, 4-module, cross-section 30 x 8 mm, length 1 m, screw-fitted on supports (supplied) Portata massima 800 kg.
	N999156	SFI	Anchor base for ARES and ICARO (supplied with operator)
	P125018	THEKE B PRA 01	Metal protection box for ARES and ICARO series sliding operators
	N190039	CSP 10	Rubber shock absorber profile length 1000 mm
	N190040	CSP 20	Rubber shock absorber profile length 2000 mm
	N190104	BIR C	Rubber safety edge (H 30 mm), price per m
	P111450 00002	BAR C 2	Double profile rubber safety edge (L 2000 x H 60 mm)
	D113749 00002	RADIUS B LTA 230 R2	Flashing light without incorporated antenna for motors with power supply 230 V.
	D113748 00002	RADIUS B LTA 230 R1	Flashing light with incorporated antenna for motors with power supply 230 V.
	P123025	B 00 R02	Wall mounting for B LTA series flashing beacons
	P123026	B 00 R01	Metal guard for B LTA

Product

PLUS

CONTROL UNIT
TECHNICAL FEATURES

ACCESSORIES

DISCOVER U-LINK

	Code	Name	Description
	D111904	MITTO B RCBO2 R1	Transmitter with 2 channels. Range 50/100 m. Power supply 12 V with 1 battery type 23 A
	P121016	RB	4-channel wall-mounted radio control with rolling code
	P121024	Q.BO TOUCH	Wireless digital touchpad with 433MHz rolling code operation. Manages up to 10 channels and 100 codes.
	P121025	Q.BO PAD	Vandalproof outdoor digital button panel. Metal structure and s/steel buttons. Compatible with WIEGAND protocol, it ensures maximum system safety as it does not directly control gate opening.
	P121022	Q.BO KEY WM	Key selector for outdoor use with double contact.
	P121023	Q.BO KEY WM AV	Vandalproof key selector with double contact, for outdoor use. Metal structure. Vandalproof key selector with metal structure.
	P111526	DESME A15	Pair of self-aligning photocells. Range 30 m. Power supply 24 V ac/dc. Pair of self-aligning photocells. Range 30 m. Power supply 24 V ac/dc.
	P111527	DESME A15 O	Pair of photocells adjustable 40 ° horizontally and 10 ° vertically. IR signal synchronised to prevent any risk of blinding. Range 30 m. Power supply 24 V ac/dc.
	P111528	THEA A15 O.PF	Pair of adjustable photocells with integrated flashing light. Possibility of directing the beam 40 ° horizontally and 10 ° vertically. IR signal synchronised to prevent any risk of blinding. Range 30 m. Power supply 24 V ac/dc. For external application.
	N190106	STR	Pair of infrared STR sensors for ERIS A30
	P903018	PHP	Pair of aluminium posts for THEA/DESME series photocells Height 522 mm
	P111531	B EBA BLUE ENTRY ANDROID 4	BLUE-TOOTH expansion card for Blue Entry system. Manages up to 4 smartphones with the Android operating system
	P111468	B EBA RS 485 LINK	Expansion board for connection of central units with serial controls management
	D831081	CMS	Sign

· Product

· PLUS

· CONTROL UNIT
· TECHNICAL FEATURES

· ACCESSORIES

· DISCOVER U-LINK

What is U-Link?

The innovative technology that gives you new power

An exclusive Bft innovation: U-Link (Universal Link) is an exclusive Bft platform that allows the creation of technological ecosystems. In Home Automation Access, it allows communication with all the home access automation devices of any brand. So you save time and can control everything with ease, without any worries.

It is intuitive

Easy to install and use

It is scalable

Allows an unlimited number of devices to be added

It is flexible

Allows the creation of groups of interconnected products

It is practical

Works with or without a web connection

It is functional

Parameters can be controlled remotely via dedicated applications

· Product

· PLUS

· CONTROL UNIT
· TECHNICAL FEATURES

· ACCESSORIES

· DISCOVER U-LINK

All in one scheme: discover this amazing technology

A unique platform **allowing the creation of technological ecosystems** offering a wide range of solutions for different sectors.

Thanks to the B-Eba cards and the Clonix U-Link receiver, this proprietary platform featured by Bft products adapts to any protocol and access automation product (even BFT, non-native U-Link or non-BFT products), and is used in various sectors. Each device thus becomes smart and can be interconnected with other systems, thanks to a language that becomes universal.

U-Base 2



Software to install and easily and comfortably carry out maintenance and identify any malfunction of U-link compatible operators.

U-SDK



U-SDK is the innovative application that can make Bft automation systems compatible and easily integrated with a BMS network for the supervision of buildings.



Magistro

An innovative and easy to install system for easily managing all home automation systems.



U-Control

U-Control is the application that helps the quick and easy integration of BFT automation systems in large building management systems.



Blue-Entry

Technology abreast of the times and attentive to daily needs: thanks to the use of U-link the house gate can now be opened with just your smartphone.



Clonix U-Link

Allows the connection of non-native U-Link products or non-Bft products to U-Link systems.

Bft operators, non-native U-Link products or a product belonging to other brands: can they be connected to U-Link? Yes, thanks to the Clonix receivers. Accessories that know no limits.



B-eba

A direct line with your operators.

B-eba expansion cards allow the connection of external devices, such as PCs, smartphones and tablets, to a Bft operator or Clonix receiver, or the connection of several Bft products in a U-Link network. These accessories integrate with U-Link technology and Bluetooth, Z-Wave, TCP/IP protocols, as well as the RS485 serial connection.

A device that fully translates what Bft means for interconnectivity.

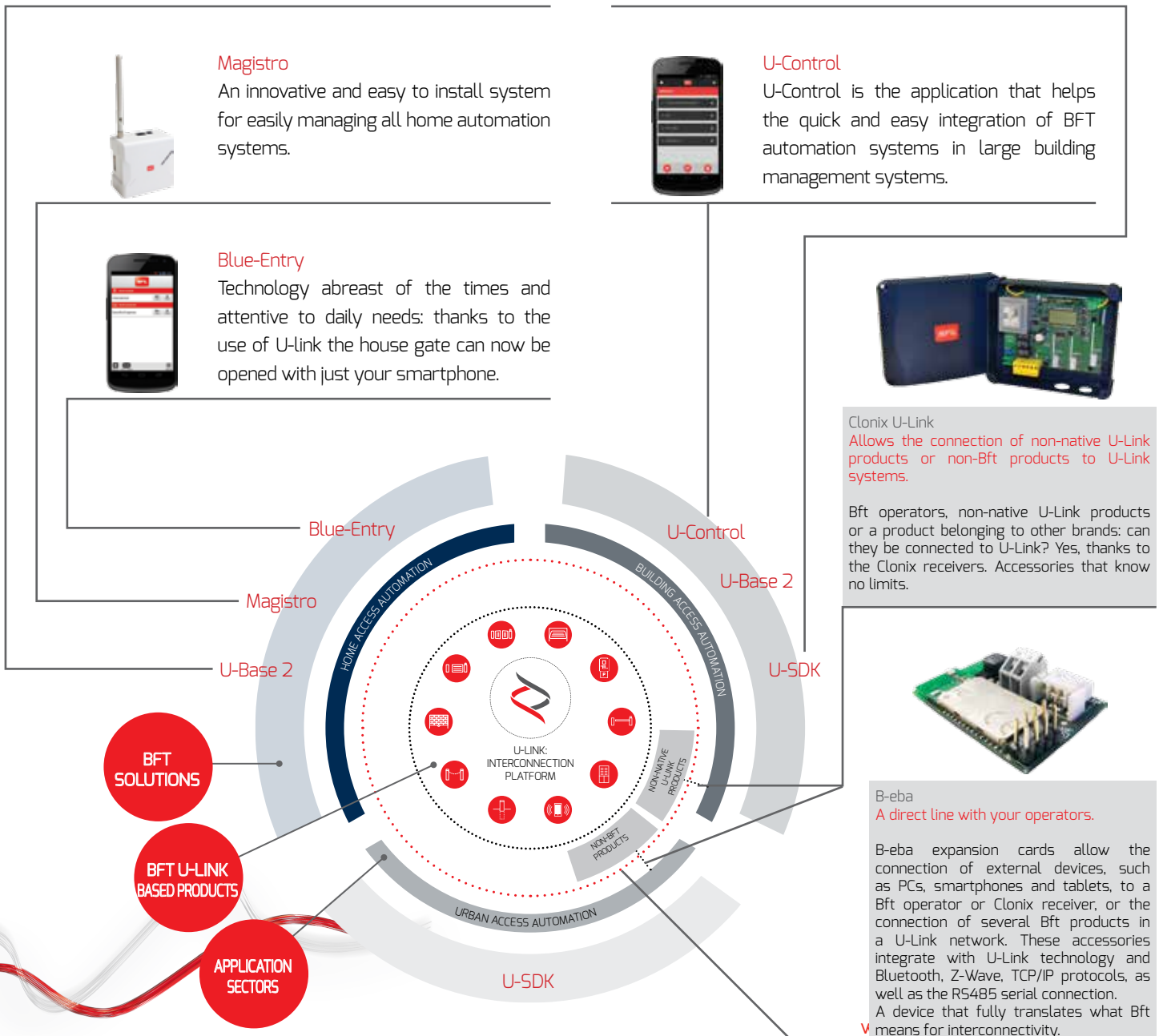



INFORMATION REGARDING THE PROTECTION OF THE INDUSTRIAL AND INTELLECTUAL PROPERTY RIGHTS OF BFT. BFT S.p.A. protects its industrial property by depositing trademarks, patents, models and designs. The intellectual property of BFT S.p.A. is protected by copyright law. BFT S.p.A. also protects its know-how by taking measures to protect the technical and commercial information inherent in its company and products. All the products in this catalogue are ORIGINAL BFT MODELS and only BFT S.p.A. is authorised to produce them and market them anywhere in the world. All the commercial names in this catalogue are owned by BFT S.p.A., and only BFT S.p.A. is authorised to use them in relation to the corresponding merchandise category. FALSIFIERS WILL BE PROCEEDED AGAINST IN ACCORDANCE WITH BOTH CIVIL AND CRIMINAL LAW. THESE CONDITIONS NOT ONLY GUARANTEE THE INTELLECTUAL PROPERTY RIGHTS OF BFT, BUT ALSO PROTECT CUSTOMERS BY GUARANTEEING THAT THE PRODUCTS THEY ARE PURCHASING ARE ORIGINAL BFT PRODUCTS RESULTING FROM STUDIES AND DESIGNS WITHIN THE BFT COMPANY.