

Series VA/VG20, VA/VG35 and VG80 Mobile Control Valves

Service and Parts Bulletin
Bulletin MSGHY14-2004-M1/US



ENGINEERING YOUR SUCCESS.

Table of Contents

Introduction	1
General Information.....	1
Replacement Parts.....	1
Maintenance.....	1
Exploded View of Work Section	2
Parts List for Work Section	3
Valve Disassembly Instructions.....	4
Cleaning, Inspection, and Repair	6
Valve Assembly Instructions	7
Cutaway for VA/VG Remote Control Operators	11
Remote-Control Operator Disassembly.....	12
Remote-Control Operator Assembly.....	14
Cutaway for Pneumatic Control Operators	16
Pneumatic Section Disassembly.....	17
Pneumatic Section Assembly.....	19
Cutaways for Main Relief Valves	22
Cutaways for Port Relief Valves	23
Screw-Adjustable, Relief-Valve Pressure Ranges and Adjustments	24
DVA20 - DVG20 - VA20 - VG20 - Valve Seal Kits	25
DVA20 - DVG20 - VA20 - VG20 - Handle Assemblies ...	25
DVA35 - DVG35 - VA35 - VG35 - Valve Seal Kits	26
DVG80 - VG80 Valve Seal Kits	26
Troubleshooting.....	27
Safety Guide.....	28

WARNING

FAILURE OR IMPROPER SELECTION OR IMPROPER USE OF THE PRODUCTS AND/OR SYSTEMS DESCRIBED HEREIN OR RELATED ITEMS CAN CAUSE DEATH, PERSONAL INJURY AND PROPERTY DAMAGE.

This document and other information from The Company, its subsidiaries and authorized distributors provide product and/or system options for further investigation by users having technical expertise. It is important that you analyze all aspects of your application and review the information concerning the product or system in the current product catalog. Due to the variety of operating conditions and applications for these products or systems, the user, through its own analysis and testing, is solely responsible for making the final selection of the products and systems and assuring that all performance, safety and warning requirements of the application are met.

The products described herein, including without limitation, product features, specifications, designs, availability and pricing, are subject to change by Parker Hannifin Corporation and its subsidiaries at any time without notice.

Offer of Sale

The items described in this document are hereby offered for sale by The Company, its subsidiaries or its authorized distributors. This offer and its acceptance are governed by the provisions stated in the "Offer of Sale".

Introduction

Introduction

This manual has been prepared to assist you in the proper maintenance of the VA20/VA35 and VG20/VG35/VG80 directional control valves. Before any work is done, we suggest that you read the assembly and disassembly instructions completely.

The first rule of good maintenance is cleanliness, which includes a clean environment. **MAKE SURE YOU DISASSEMBLE AND ASSEMBLE YOUR HYDRAULIC EQUIPMENT IN A CLEAN AREA.** Dirt is the natural enemy of any hydraulic system.

General Information

The VA and VG model valves are updated versions of our proven A20™ and A35™ units. The VG models are cast from compacted graphite, a high strength iron alloy, which allows the valve to be rated to 3500 psi. VA models are cast from gray iron and are rated at 2500 psi. These open-center, directional-control valves are available in parallel, tandem, and series circuitry. As needed, the sectional, stack-type construction provides flexibility for the addition of subtraction of work sections to an existing valve bank. This design also permits the combination of parallel, tandem, and series circuitry in

a single bank. The internal coring of each valve section determines its circuitry and the number of gasket seals required.

All sections with optional features, such as port relief valves, crossover relief valves, and anticavitation checks, are dimensionally larger when measured from the top of the port to the bottom of the housing. These are referred to as “hi-boy” sections. Those without work-port options can use the low-profile castings, which are called “loboy” sections.

Replacement Parts

The illustrations and instructions in this manual apply only to the VA/VG series assemblies, subassemblies, and components. All valve components, except for spools and housings, are available as replacement parts or subassemblies. Spools are hone-fitted to their individual housings, so damage to either of these components means the entire section must be replaced.

We recommend that you use only genuine VA/VG series replacement parts in your service program. Manufactured to the same exacting tolerances and quality controls as the original equipment, genuine VA/VG replacement parts may help prevent premature, component failure and costly downtime. Service parts and assemblies are available through your original equipment dealer or any authorized distributor.

Maintenance

Valves are often used in hazardous environments. Inspect them frequently for damage due to improper use, corrosion or normal wear. If needed, repairs should be made immediately.

Always refer to the machine manual for the proper procedure to remove the valve from the machine.

Remove the valve bank from the equipment, disconnecting all hoses, fittings, control handles and linkage connectors that might be attached to the valve. Plug all ports and thoroughly clean the exterior of the valve bank, then the port plugs can be removed.

Exploded View of Work Section

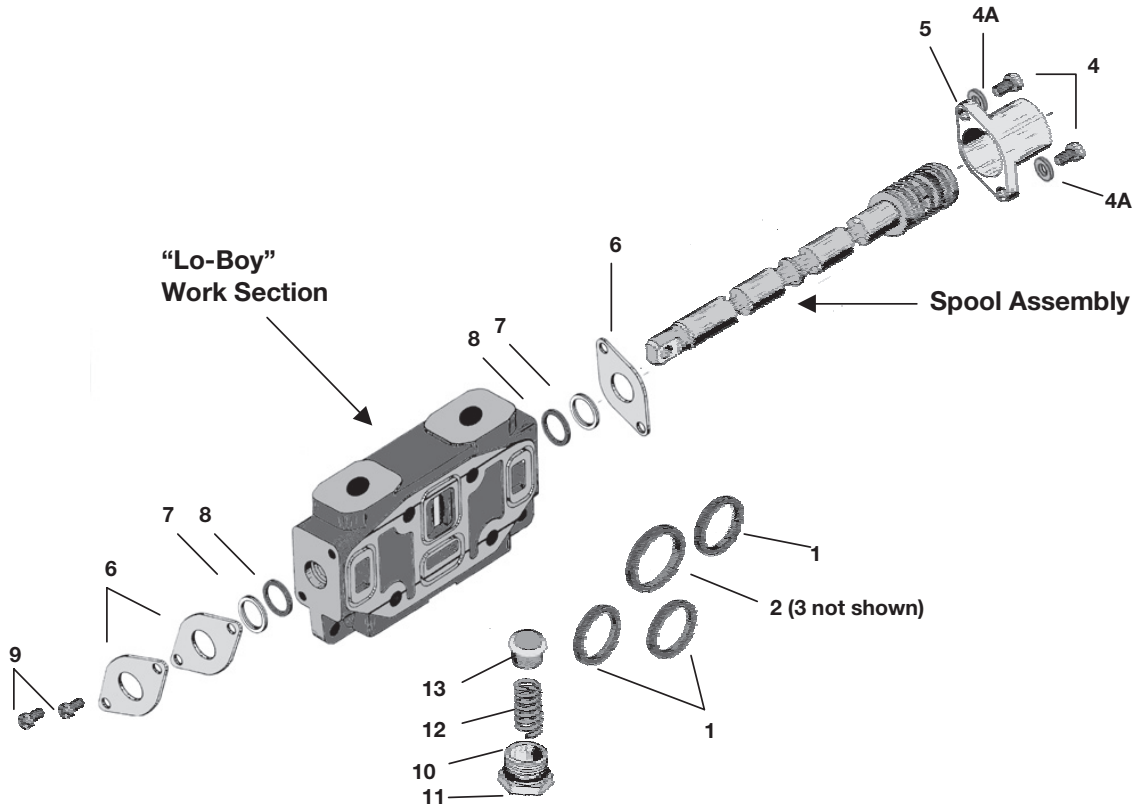

Figure 1

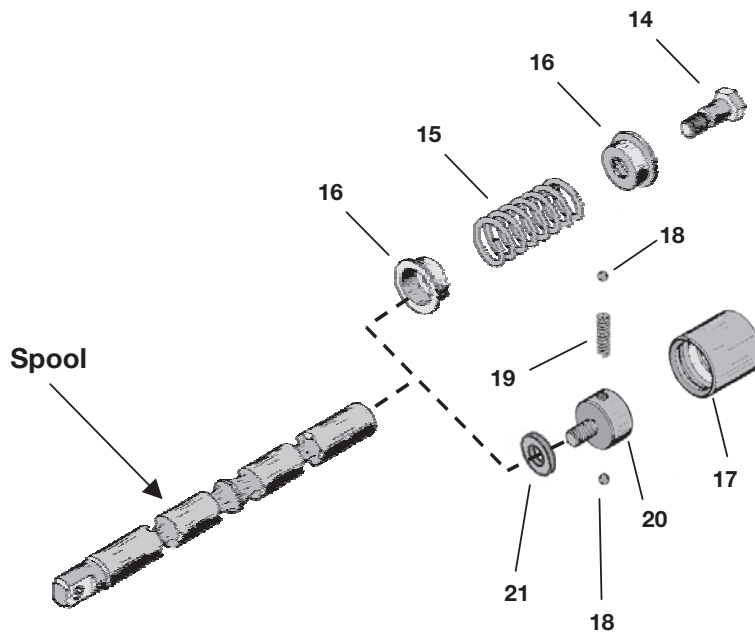

Figure 2

Parts List for Work Section

Figure 1

Item	Description	Qty.	VA/VG20 Part No.	VA/VG35 Part No.	VG80 Part No.
Parallel Section Seals*					
1	Square Seals	3	391-2881-206	391-2881-200	391-2881-433
2	Square Seal	1	391-2881-200	391-2881-403	391-2881-670
Series Section Seals					
1	Square Seals	2	391-2881-206	391-2881-200	–
3	Square Seal	1	391-2881-627	391-2881-628	–
Parallel and Series Section Component Parts					
4	Back Cap Screws	2	391-1433-020	391-1433-009	(4) 391-1402-068
4A	Lock Washers	8	–	–	391-3783-039
5	Back Cap	1	341-6000-100	342-6000-100	341-0585-099
6	Retainer Plates	3	391-2183-001	391-2183-005	391-2183-157
7	Back-up Rings	2	391-2681-378	391-2681-426	391-2681-285
8	Spool Seals	2	391-1985-014	391-2887-212	391-2881-096
9	Retainer Plate Screws	2	391-1433-015	391-1433-002	(4) 391-1402-015
10	Check Valve Cap	1	391-0581-044	391-0581-044	391-0585-099
	or Valve Cap (F.I.N.)	1	391-2281-015	391-2281-015	–
11	O-Ring Seal**	1	391-2881-204	391-2881-204	391-2881-249
12	Check Spring**	1	391-3581-713	391-3581-713	391-3581-778
13	Check Valve Poppet**	1	391-2481-069	391-2481-069	391-2383-091

Figure 2

Item	Description	Qty.	VA/VG20 Part No.	VA/VG35 Part No.	VG80 Part No.
Spring Centered and Detent Spool Operators					
14	Stripper Bolt	1	391-1432-022	391-1432-021	391-1402-452
15	Centering Spring	1	391-3581-608	391-3581-633	391-3581-330
16	Spring Guides	2	391-1642-045	391-1642-013	391-1642-161
17	Detent Sleeve	1	391-3283-015	391-3283-008	391-3384-310
18	Detent Balls	2	391-0282-010	391-0282-009	391-0282-011
19	Detent Spring	1	391-3581-130	391-3581-015	391-3581-316
20	Detent Poppet Retainer	1	391-2583-008	391-2583-006	391-3384-311
21	Detent Spacer	1	–	–	391-3782-208

*Parallel Sealing Face includes inlets and mid-inlets.

**Not required in Float-in-neutral Sections.

Valve Disassembly Instructions

Reference exploded view and parts list on page 2 for work section detail.

Step 1 - Valve Bank

This step is the most critical in the disassembly procedure. It should be followed closely to ensure that the valve bank is properly reassembled after repairs have been made.

With a waterproof, quick-drying marker, mark each casting with a sequential number. Start by marking the inlet casting with the #1 and finish by marking the outlet with the highest number.

Next, mark the port boss closest to the back cap on each work section with a "B" (for back cap end).

Then, mark the port boss closest to the spool clevis on each work section with a "C" (for clevis end).

Finally, if relief valves are removed from the valve bank they must be marked with the corresponding number of the casting and port location (B or C) from which they were removed. Inlet and mid-inlet relief valves are marked with a casting number only.

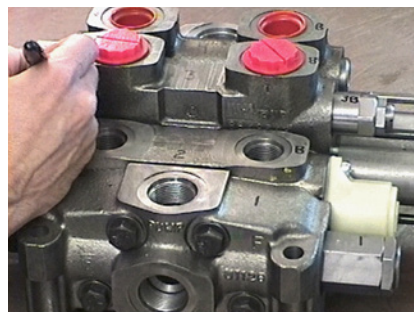

Step 2 - Tie Bolts

Remove the four, tie bolts that hold the bank together and separate the sections.

NOTE: VA valve tie bolts thread into the outlet casting. VG valve tie bolts pass through the entire bank, requiring washers and hex nuts to be fastened at both ends of the bolt.

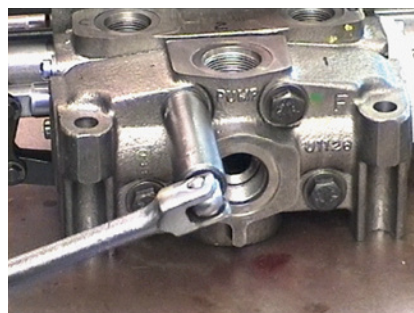

Step 3 - Section Seals

The inlet, mid-inlet and each parallel work section have four, section seals, (Fig. 1, items 1 & 2) on the downstream, mating face. Series work sections and the VA/VG35 split flow mid inlets have three section seals on the downstream mating face, (Fig. 1, items 1 & 3.) These section seals should be removed and discarded.

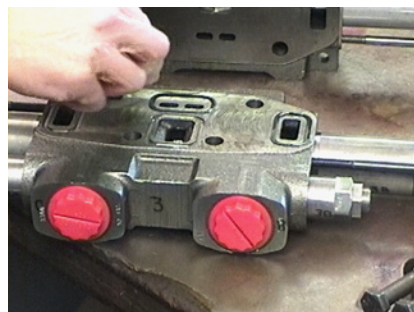

REMINDER: ALL WORK MUST BE PERFORMED IN A CLEAN AREA.

Step 4 - Valve Back Cap

Using a large, Phillips-head screwdriver, remove the two, cap screws (Fig. 1, item 4) which fasten the back cap to the work section. Lightly tap the end of the screwdriver handle with a hammer to break adhesive. Remove the back cap (Fig. 1, item 5).

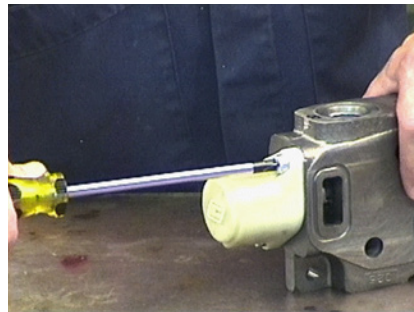

Step 5 - Control Spool and Seals

Grasp the spring end of the spool with a clean, lint-free cloth and pull the spool out of the housing using a twisting motion. Generally, the rear, retainer plate (Fig. 1, item 6) back-up ring (Fig. 1, item 7) and spool seal (Fig. 1, item 8) will come out with the spool.

CAUTION: For detented spool models, be careful not to remove the detent poppet sleeve (Fig. 2, item 17) unless it is to be serviced.

Using a large, Phillips-head screwdriver, remove the two, retainer-plate screws (Fig. 1, item 9) from the spool clevis end of the work section. Lightly tap the end of the screwdriver handle with a hammer to break the adhesive. Remove the two, retainer plates (Fig. 1, item 6) the back-up ring (Fig. 1, item 7) and the spool seal (Fig. 1, item 8). Tag or mark with the appropriate, work section identification number. (See Step 1.) Spool seals (Fig. 1, item 8) and back-up rings (Fig. 1, item 7) should be discarded.



Step 6 - Transition Check

The transition check is located in the bottom center of the work section housing. Carefully clamp the work section in a vise with ports down. Do not clamp on the machined surface. Remove the check-valve cap (Fig. 1, item 10) and its O-ring seal (Fig. 1, item 11). Discard the seal. Remove the check spring (Fig. 1, item 12,) and the check-valve poppet (Fig. 1, item 13).

NOTE: Only cylinder work sections (ports blocked in neutral) have a transition check. Motor sections have only a cap plug.

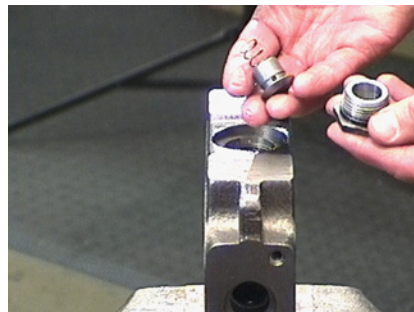

Valve Disassembly Instructions cont.

Spool Disassembly

Spring Centered Spool

The spring assembly should not be removed from the spool unless these parts need to be replaced. Once the spool is free of the work section housing, it must be handled carefully to avoid damage. Place the spool vertically in a soft-jawed vise, clamping on the flat, spool clevis, and remove the stripper bolt (Fig. 1, item 14) with a wrench.

Lightly tap the stripper bolt with a hammer and a punch to help break the adhesive. Cautious application of heat may be required to free the stripper bolt, since an anaerobic thread adhesive was used during its assembly.

CAUTION: Too much heat may distort the spool.

As the stripper-bolt threads disengage, the spring (Fig. 2, item 15) and spring guides (Fig. 2, item 16) will release abruptly from the spool.



Detent Spool

The detent assembly should not be removed from the spool unless these parts need to be replaced. Wrap the detent sleeve (Fig. 2, item 17) with a clean, lint-free cloth. Grip the cloth-covered sleeve and pull firmly. As the sleeve moves backwards, the detent balls (Fig. 2, item 18) and the detent spring (Fig. 2, item 19) will release abruptly. The cloth should capture these parts and prevent their loss.

Next, clamp the spool in a soft-jawed vise and remove the detent poppet retainer (Fig. 2, item 20). Place an undersized bar through the detent ball bore to serve as a wrench. Lightly tap the detent poppet retainer with a hammer and a punch to help break the adhesive. Cautious application of heat may be required again, since an anaerobic adhesive was also used in the detent retainer assembly.

CAUTION: Too much heat may distort the spool!



Cleaning, Inspection, and Repair

- Step 1. Inspect the spool bore, transition check seat and spool from each section for deep scratches, gouges or excessive wear. If any of these conditions exist, replace the section. Minor, surface damage on the control spool and check poppet can be carefully polished away with a very fine, crocus cloth.
- Step 2. Examine the machined surfaces of the valve housing for nicks and burrs that could cause leakage between sections. Lightly stone these surfaces to remove any rough spots.
- Step 3. Wash all parts thoroughly in a cleaning solvent and blow dry before beginning reassembly. Pay special attention to the number and letters marked on the parts in Step 1. If any marks are removed during cleaning, re-mark immediately.
- Step 4. Clean adhesive from threads of spool, stripper bolt, housing, cap screws and hex nut with Loctite™ Chisel Step Gasket Remover.

CAUTION: A shallow-milled relief area extends across the O-ring face of the valve housing. This should not be stoned or ground off!

Valve Assembly Instructions

Preparation of Parts

Spray the threads of the new stripper bolt (Fig. 2, item 14) tapped-threaded spool end, all screws and screw holes on both ends of the housing with LOCQUIC Primer Grade NF™ and let dry.

CAUTION: Failure to follow the recommended assembly instructions can result in poor performance or product malfunction. Product should be thoroughly tested to ensure proper operation before the valve is placed back into service.

Spring Center Spool Assembly

Step 1 - Spool Assembly-Spring Centered

Clamp the flat, clevis end of the control spool in a soft jawed vise. Apply Parker Super-O-Lube™ to the spool seal (Fig. 1, item 8) and slide it onto the end of the spool away from the clevis. Slide on the back-up ring (Fig. 1, item 7) and retainer plate (Fig. 1, item 6). Position these items onto the spool, so that they do not interfere with the spool operator mechanism during assembly. Do not allow the O-ring to come in contact with the sharp edge of the spool notches.

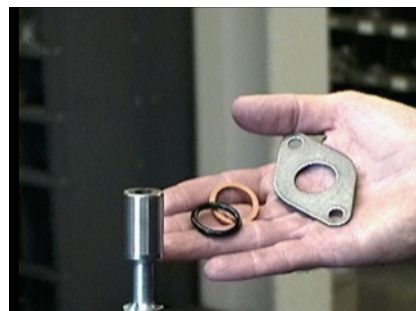

Step 2 - Attach Spring Guides and Spring

Apply 2 - 3 drops of Loctite 262™ or equivalent anaerobic adhesive near the middle of the female threads in the spool. Assemble the spring guides (Fig. 2, item 16) centering spring (Fig. 2, item 15) and stripper bolt (Fig.2, item 14) onto the spool (Reverse of Step 7). Torque the stripper bolt to 175 in. lbs. +/-4 in. lbs.

CAUTION: Care must be taken to ensure that the spring retainer is not pinched under the shoulder bolt during assembly. This can result in burrs that may cause spool binding. Check for binding by compressing the spring and guides or by rotating the spring guide nearest the housing.

Lightly coat the centering spring with high- temperature grease to prevent rusting. Set the spool assembly aside and let it cure for a minimum of 1 hour. After curing, test the stripper bolt to make certain it can withstand 125 in. lbs. of breakaway torque.

CAUTION: Follow the adhesive manufacturer's instructions for proper cleaning and curing. Failure to clean and prepare parts properly may result in assembly failure!



Valve Assembly Instructions cont.

Detent Spool Assembly

Step 1 - Spool Assembly-Detent

Apply Parker Super-O-Lube™ to the spool seal (Fig. 1, item 8) and slide it onto the spool. Slide the back-up ring (Fig. 1, item 7) and one, retainer plate (Fig. 1 item 6) onto the spool. Position these items onto the spool, so that they do not interfere with the spool operator mechanism during assembly. Do not allow the O-ring to come in contact with the sharp edge of the spool notches. Apply 2 - 3 drops of Loctite 262™ or an equivalent, anaerobic adhesive near the middle of the female threads in the spool.

CAUTION: Follow the adhesive manufacturer's instructions for proper cleaning and curing. Failure to clean and prepare parts properly may result in assembly failure.



Step 2 - Spool Assembly-Detent

Thread the detent ball retainer (Fig. 2, item 20) into the spool end. Torque the detent ball retainer to 175 in. lbs.+/-4 in. lbs. This can be accomplished by using a crows-foot socket on the flats of the clevis, and holding the spool by inserting a round, steel rod or screwdriver through the hole in the ball retainer.



Step 3 - Detent Balls and Spring

Next, lightly coat the detent balls (Fig. 2, item 18) detent spring (Fig. 2, item 19) and entire inside diameter of the detent sleeve (Fig. 2, item 17) with high-temperature grease.

Insert the detent spring into the through hole in the detent ball retainer. Place the steel balls on the ends of the spring. Compress the balls and spring, then slip on the detent sleeve. (Note: The detent sleeve is not symmetrical; one end of the sleeve has a lead-in chamfer. This chamfer must face the spool clevis when assembled.) Move the detent sleeve to the neutral or middle position to prevent the subassembly from separating during subsequent steps.



Step 1 - Spool Subassembly

Apply 2 - 3 drops of Loctite 262™ or equivalent to the fillister screw holes on both ends of the housing.

Apply a light coating of clean, hydraulic oil to the valve spool. Carefully insert the spool assembly into the housing. Use caution to avoid causing burrs. Be careful not to pinch, roll or damage the seals. Make sure that the spool and housing are in the proper orientation (see Step 1, page 6 disassembly).

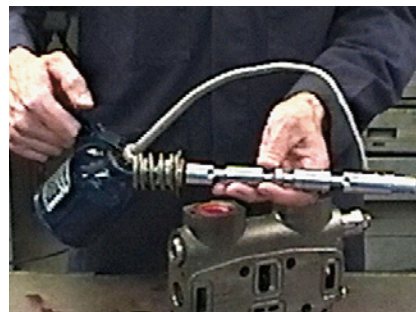

Step 2 - Spool Seal and Back-Up

Apply Parker Super-O-Lube™ to the spool seal (Fig. 1, item 8) and slide it onto the spool. Slide on the back-up ring (Fig. 1, item 7). Push both items into the counter-bore until they bottom out.

Assemble the two, front, retainer plates (Fig. 1, item 6) using the two short, fillister screws (Fig. 1, item 9). Check retainer plates for proper alignment. Tighten to a final torque of 34 in. lbs. +/- 2 in. lbs.



Step 3 - Back Cap

Install the back cap using the two, long, fillister screws (Fig. 1, item 4). Tighten to a final torque of 34 in. lbs. +/- 2 in. lbs.

CAUTION: Excessive torque will damage the back cap ears!

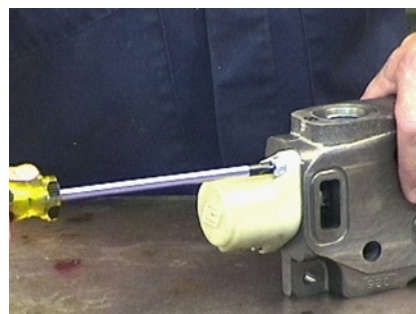

Valve Assembly Instructions cont.

Step 4 - Install Transition Check

Inspect transition check components for cleanliness. Install check poppet (Fig. 1, item 13) into the transition check cavity. Align the check spring (Fig. 1, item 12) square to the poppet, then carefully place the check cap (Fig. 1, item 11) over the poppet and spring. Turning by hand, engage several threads. Tighten to a final torque of 75 ft. lbs. +/-4ft. lbs.



Step 5 - Relief Valves

Return all relief valves to their proper positions and torque to 75 ft. lbs.

Install new, section seals. Place section seals (Fig. 1, items 1 & 2, or items 1 & 3) in the proper grooves. Make certain seals stay in their grooves during assembly.



Step 6 - Install Tie Bolts

Slide the tie bolts through the inlet casting. If cap screws are used, place a washer on the cap screw prior to installation. Place the valve sections on the tie bolts in their proper sequence (see Step 1, page 4). Turning by hand, engage several threads in the outlet. If it is a VG series assembly, assemble nut and washer to either end of the stud and follow above instructions. Torque the tie bolts in a cross-corner pattern.



Tie Bolt Torque Values

VA20 - 29 ft. lbs.
(348 in. lbs.)

VG20 - 42 ft. lbs.
(504 in. lbs.)

VA35 - 34 ft. lbs.
(408 in. lbs.)

VG35 - 75 ft. lbs.
(900 in. lbs.)

VG80 - 150 ft. lbs.
(1800 in. lbs.)

Cutaway for VA/VG Remote-Control Operators

Read these instructions carefully. Failure to follow these procedures can result in poor performance or product malfunction. Make sure all work is done in a clean area.

Figure 3: Remote Cap Components

- | | | |
|-------------------------|-------------------------|------------------|
| 1. O-rings (2) | 5. Return spring, outer | 9. End tubes (2) |
| 2. Seal retainers (2) | 6. Valve caps (2) | 10. O-rings (4) |
| 3. Shoulder bolt | 7. Spring retainers (2) | 11. Stop tube |
| 4. Return spring, inner | 8. Cap screws (4) (8*) | |

*Required for VG80

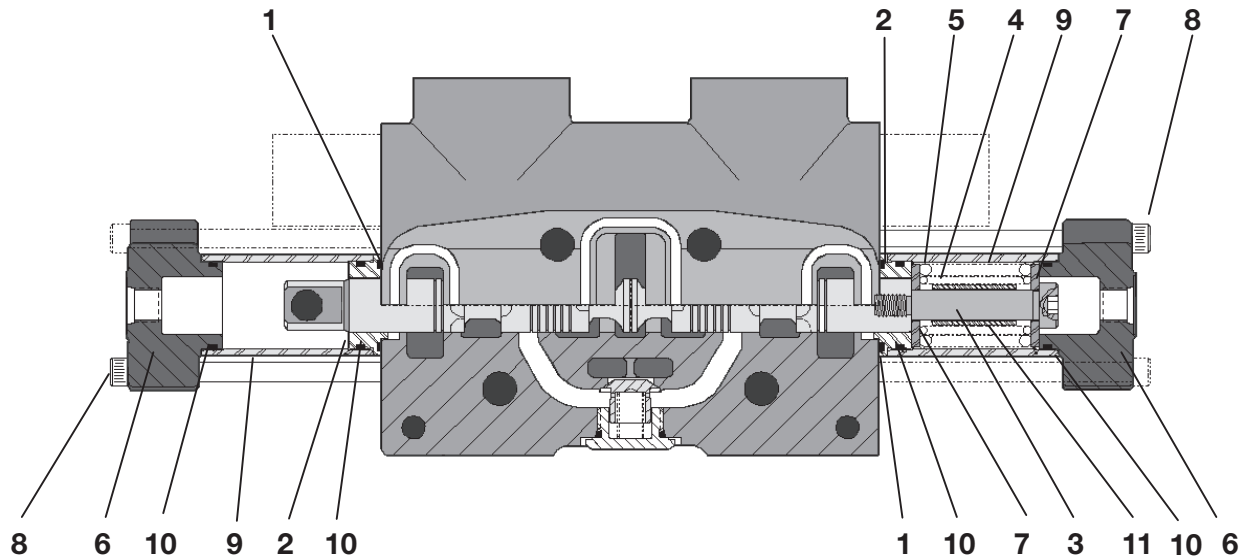

Figure 3: Hydraulic Remote Control

Remote Endcap Seal Parts List

Item	Description	Qty.	VA/VG20	VA/VG35	VG80
13	O-Rings	2	391 2881 625	391 2881 62	391 2881 124
10	O-Rings	4	391 2881 242	391 2881 242	391 2881 106

Remote-Control Operator Disassembly

Step 1 - Remote Endcaps

Using an allen wrench, remove cap screws (Fig. 3 item 8) from both ends of the valve section. Lightly tap the wrench with a hammer to help break the bond of the anaerobic adhesive.

Remove valve caps (Fig. 3, item 6) O-ring seals (Fig. 3, item 10) and end tubes (Fig. 3, item 9) from each end of the valve housing. Discard the O-ring seals.

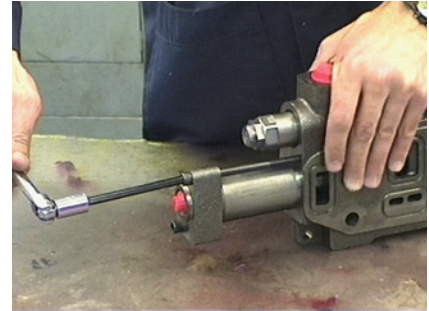

Step 2 - Spool Subassembly

Slide the seal retainer (Fig. 3, item 2) from the clevis end of the spool assembly. Grasp the spool assembly by the spring end and slide it out of the housing. Remove the remaining seal retainer by sliding it over the spool.

Now, remove the O-ring seals (Fig. 3, items 1 & 10) from both seal retainers and discard the seals.

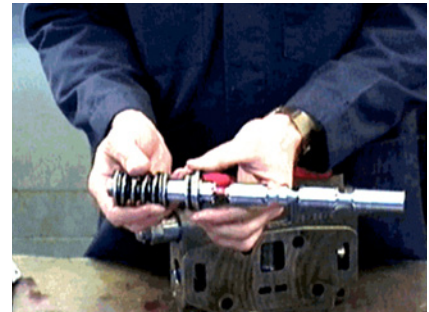

Step 3 - Spool Identification

The spool should now be tagged or marked with the appropriate work section identification number (see Step 1, page 4).

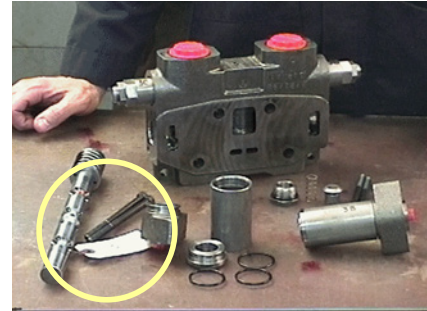

Step 4 - Spring Pack

The spring assembly should not be removed from the spool unless it needs to be replaced. Insert the clevis end of the spool in a soft-jawed vice. It may be necessary to apply heat to the stripper bolt to loosen the anaerobic adhesive.

Use heat carefully to avoid warping the spool.



ALWAYS WORK IN A CLEAN ENVIRONMENT

Remote-Control Operator Assembly

Step 1 - Spring Pack

If the shoulder bolt and spring assembly were disassembled, place the spool in a soft-jawed vise with the tapped and threaded end up. Carefully clamp on the flat, spool clevis. Apply 2 - 3 drops of Loctite 262™ or equivalent to the middle of the female threads in the spool end. Assembled joints should be allowed to cure for a minimum of one hour before being subjected to hydraulic testing.

Slide a spring retainer (Fig. 3, item 7) onto the shoulder bolt (Fig. 3, item 3) followed by the stop tube (Fig. 3, item 11). Next, slide spring retainers (Fig. 3, items 4 & 5) onto the shoulder bolt. Place the remaining spring retainer on the end of the spool and thread the shoulder bolt into the hole by hand. Torque the shoulder bolt to 175 in. lbs. using a torque wrench.

CAUTION: Care must be taken to ensure that the spring retainer is not pinched under the shoulder bolt during assembly. This can result in burrs that may cause spool binding.



Step 2 - Seal Retainers

Install the two, O-ring seals (Fig. 3, items 1 & 10) on both seal retainers (Fig. 3, item 2). Apply Parker Super-O-Lube™ to the O-ring seals.

CAUTION: The O-ring seals are similar in size. Be sure to insert O-ring seals 1 & 10 in their proper position. They are not interchangeable!



Step 3 - Spool Installation

Apply 2 - 3 drops of Loctite 262™ or equivalent to the cap screw holes on both ends of the housing.

Slide one seal retainer over the spool, resting against the spring retainer. Make sure the O-ring (Fig. 3, item 1) is facing the section casting. Apply a light coating of clean, hydraulic oil to the valve spool. Carefully insert the spool into the housing. Use caution to avoid causing burrs.



Step 4 - Assemble Endcaps

Apply a light coat of grease to the valve-cap O-rings (Fig. 3, item 10). Assemble the O-rings onto both of the cast-iron valve caps (Fig. 3, item 6). Slide the end tube (Fig. 3, item 9) over the spring end of the spool. Position the cast-iron valve cap, as shown, on the end tube and push into place. Be careful not to shear the valve-cap seal during installation.

Install two, cap screws (Fig. 3, item 8) tighten evenly and torque to the final specification.

VA20/VG20 to 100 in. lbs.

VA35/VG35 to 175 in. lbs.

VG80 to 175 in. lbs.

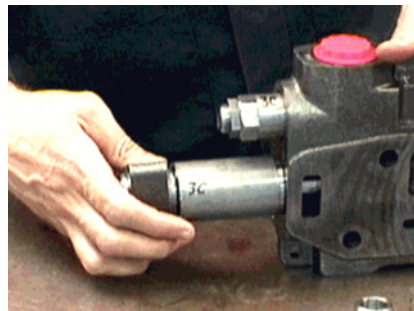

Step 5 - Complete Endcap Assembly

Install seal retainer (Fig. 3, item 2) with seals on the clevis end of the spool. Install the end-cap tube (Fig. 3, item 9) the valve cap (Fig. 3, item 6) and the cap screws (Fig. 3, item 8) as previously explained.

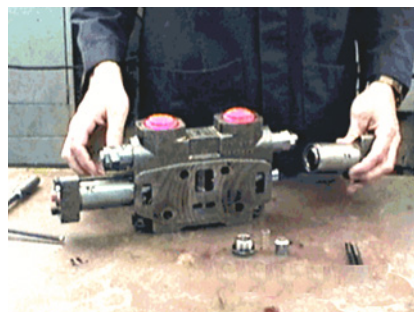

Step 6 - Assemble Transition Check

Inspect the transition-check components for cleanliness. Install a new O-ring seal (Fig 1, item 11) on the check-valve cap. Place the check poppet (Fig. 1, item 13) into the housing. Align the check spring (Fig. 1, item 12) square to the poppet, then carefully place the check cap (Fig. 1, item 10) over the check poppet. Turning by hand, engage several threads. Tighten to final torque of 75 ft. lbs. +/- 4 ft. lbs.

CAUTION: Failure to follow these recommended assembly instructions can result in poor performance or product malfunction. Product should be thoroughly tested to ensure proper operation before the valve is put back into service.

USE ONLY ORIGINAL VA/VG SERIES REPLACEMENT PARTS

Cutaway for Pneumatic Control Operators

Figure 4 : Pneumatic Cap Components VA/VG20 AND VA/VG35

- | | | |
|--------------------|---------------------|-----------------------|
| 1. Retaining plate | 8. Spring retainer | 15. O-rings (2) |
| 2. Spacer tube | 9. Stripper bolt | 16. Wiper seals (2) |
| 3. Spacer | 10. Stop tube | 17. Retainer plate |
| 4. Flange | 11. Spring | 18. Washers (2) |
| 5. Pressure tube | 12. Spring retainer | 19. Cap screws (2) |
| 6. Piston | 13. Wiper seal | 20. Spool Seals (2) |
| 7. Seal retainer | 14. Piston rod | 21. Back-up rings (2) |

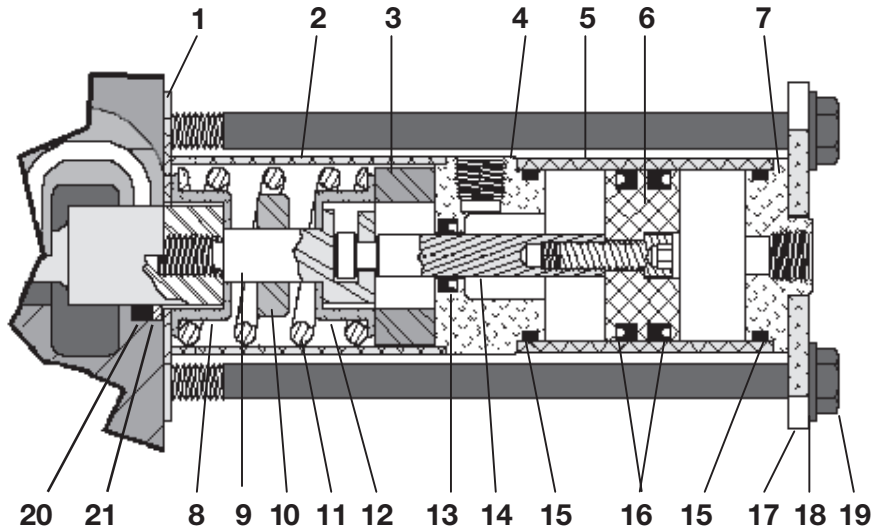

Figure 4: Single-Ended Pneumatic Cap

Seal Parts List - Figure 4

Item	Description	Qty.	VA/VG20	VA/VG35
13	Wiper Seal	1	391 2883 165	391 2883 165
15	O-Rings	2	391 2881 625	391 2881 625
16	Wiper Seals	2	391 2883 164	391 2883 164

Pneumatic Section Disassembly

Step 1 - Pneumatic Endcap

Remove the two, hex-head cap screws (Fig. 4, item 19) and retainer plate (Fig. 4, item 17). Since Loctite™ was used to hold fasteners, slide the Endcap and spool out of the valve body as one assembly.

Remove the two, retainer screws (not shown) from the clevis end of the spool, lightly tapping the end of the screwdriver handle with a hammer to break adhesive. Remove the two, retainer plates, back-up ring and spool seal. Discard the spool seals and back-up rings from both ends of the work section.

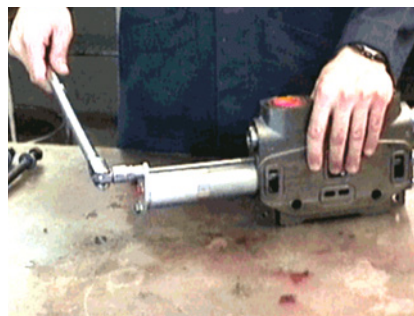

Step 2 - Spacer Tube

Next, slide the spacer tube (Fig. 4, item 2) off of the spool to expose the spring (Fig. 4, item 11) and spring retainers (Fig. 4, items 8 and 12). Disconnect the piston rod (Fig. 4, item 14) from the stripper bolt (Fig. 4, item 9). Slide the spacer (Fig. 4, item 3,) and flange (Fig. 4, item 4) off the piston rod. Remove the wiper seal (Fig. 4, item 13) and O-ring (Fig. 4, item 15) from the flange and discard.



Step 3 - Spool Identification

The spool should now be tagged or marked with the respective, work-section identification number (see Step 1, page 6).

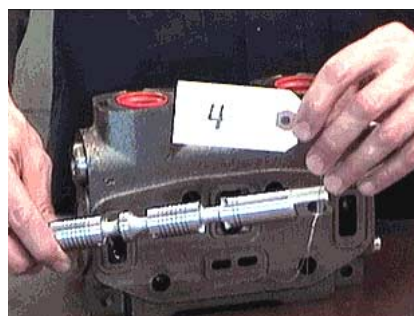

Pneumatic Section Disassembly cont.

Step 4 - Pneumatic Endcap

Slide piston (Fig. 4, item 6) and piston rod assembly out of the pressure tube, exposing the two, wiper seals (Fig. 4, item 16). Remove the wiper seals and discard. Insert a screwdriver handle into the pressure tube and dislodge the seal retainer (Fig. 4, item 7). Remove the O-ring (Fig. 4, item 15) and discard.



Step 5 - Stripper Bolt

The spring assembly should not be removed from the spool unless these parts are being replaced. Carefully place the spool clevis in a soft-jawed vise. Lightly tap the stripper bolt with a hammer and punch to break the adhesive. If it does not release, cautiously apply heat.

CAUTION: Too much heat may distort the spool.

As the stripper-bolt threads disengage, the spring (Fig. 4, item 11) and spring retainers (Fig. 4, items 8 and 12) will release abruptly.



Pneumatic Section Assembly

Step 1 - Spool Assembly

Clamp the flat, clevis end of the control spool in a soft-jawed vise. Apply Parker Super-O-Lube™ to the spool seal (Fig. 4, item 20) and slide it onto the end of the spool, away from the clevis. Slide on the Back-up ring (Fig. 4, item 21) and retainer plate (Fig. 4, item 6). Position these items onto the spool so that they do not interfere with the spool operator mechanism during assembly. Do not allow the O-ring to come in contact with the sharp edge of the spool notches.

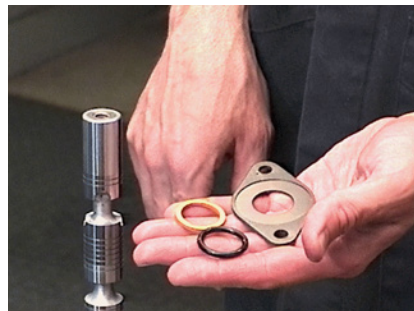

Step 2 - Spring Assembly

Apply 2 - 3 drops of Loctite RC680™ or equivalent, anaerobic adhesive near the middle of the female threads in the spool. Place the spring retainer (Fig. 4, item 8) over the end of the spool followed by the centering spring (Fig. 4, item 11). Place the stop tube (Fig. 4, item 10) in the spring and cap with the other spring retainer (Fig. 4, item 12). Insert the stripper bolt (Fig. 4, item 9) and torque to 180 in. lbs.

Apply a light coating of clean, hydraulic oil to the valve spool. Carefully insert the spool into the housing. Use caution to avoid causing burrs. Be careful not to pinch, roll or damage seals. Be certain the spool and the housing are in their original orientation.



Step 3 - Spacer Tube

Install the spacer tube (Fig. 4, item 2) over the spring with the vent hole positioned away from the section casting.

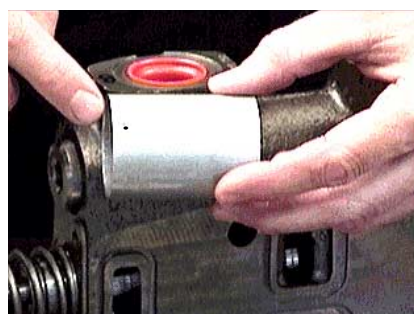

Pneumatic Section Assembly cont.

Step 4 - Air Piston Assembly

Apply Parker Super-O-Lube™ to the wiper seals (Fig. 4, item 16) and install one seal in the groove farthest from the piston rod (Fig. 4, item 6). The wiper seal has a cup design that must be installed with the open cup facing the end of the piston. Slide the piston, rod-end first, into the pressure tube (Fig. 4, item 5).

Push the piston through the pressure tube and expose the wiper seal groove closest to the rod. Install the second wiper seal with open cup facing the piston rod. Slide the piston into the pressure tube and leave the piston rod extended beyond the pressure tube.



Step 5 - Piston Subassembly

Apply Parker Super-O-Lube™ to the wiper seal (Fig. 4, item 13) and O-rings (Fig. 4, item 15). Facing the open cup inward, squeeze the wiper seal and insert it into the flange's seal groove (Fig. 4, item 4). Install one O-ring (Fig. 4, item 15) on the flange. Carefully slide the flange onto the piston rod. Pull the piston rod through the flange until the piston bottoms on the flange. Slide the spacer (Fig. 4, item 3) over the piston rod. Insert the end of the piston rod into the slot in the stripper bolt.



Step 6 - Endcap Assembly

Place the remaining O-ring (Fig. 4, item 15) on the seal retainer (Fig. 4, item 7). Install the retainer plate (Fig. 4, item 17) over the seal retainer (Fig. 4, item 7). Apply 2 to 3 drops of Loctite 262™ inside the tapped holes in the housing. Place the washers (Fig. 4, item 18) on the 6 1/4" cap screws (Fig. 4, item 19). Push the cap screws through the retainer plate and screw them into the valve housing. Make sure all parts are properly aligned and seated. Torque the cap screws to 25 - 30 in. lbs.



CAUTION: FAILURE TO FOLLOW THE RECOMMENDED ASSEMBLY INSTRUCTIONS CAN RESULT IN POOR PERFORMANCE OR PRODUCT MALFUNCTION. THE PRODUCT SHOULD BE THOROUGHLY TESTED TO ENSURE PROPER OPERATION BEFORE THE VALVE IS PLACED BACK INTO SERVICE.

Cutaways for Main Relief Valves

Main System Relief Valve

The main, relief valve protects the hydraulic system against overload pressures. It is typically located in the inlet casting and the mid-inlet sections used in the valve bank. Figure 6 illustrates the arrangement of the parts and serviceable seals for the differential-area main relief valve. Figure 7 illustrates the serviceable components found in the pilot-operated main relief. These cartridge-type relief valves are removed from the valve bank as a subassembly and replaced or serviced.

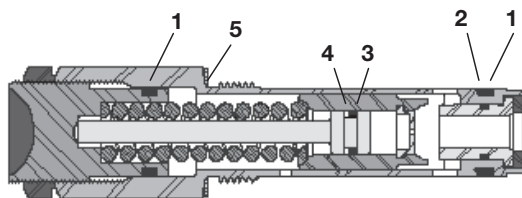

Figure 6

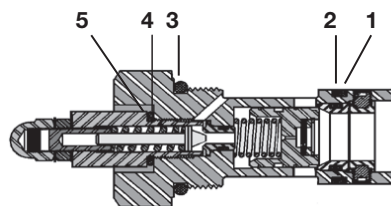

Figure 7

Service Parts List for Figure 6

Item	Description	Qty.	VA/VG20	VA/VG35
1	O-rings	3	391-2881-332	391-2881-336
2	Back-up Ring	1	391-2681-373	-
3	O-ring	1	391-2881-156	391-2881-137
4	Back-up Ring	1	391-2681-163	391-2681-165
5	Gasket Washer	1	391-1583-013	391-1583-012

*All seals in the relief cartridge are not serviceable.

Service Parts List for Figure 7

Item	Description	Qty.	NG80
1	O-ring	1	391-2881-342
2	Back-up Ring	1	391-2681-303
3	O-ring	1	391-2881-344
4	O-ring	1	391-2881-208
5	Gasket Washer	1	391-1581-001

*All seals in the relief cartridge are not serviceable.

VA20/VG20, VA35/VG35 Main Differential Area Relief Valve Part Numbers:

- 355-9107-035
- 355-9107-061
- 355-9107-013
- 355-9001-082
- 355-9107-385

VG80 Main Pilot Operated Relief Valve Part Numbers:

- 355-9001-008
- 355-9001-031

NOTE: WHEN INSTALLING RELIEF VALVE, TORQUE TO 75 FT. LBS.

Cutaways for Port Relief Valves

Work Port Relief Valve Options

The full-flow work port relief valve normally functions when the valve spool is in the neutral position. During over pressurization, fluid is discharged from the workport passage into the tank-return passage of the valve work section. The pressure setting is normally higher than that of the main, relief valve.

Avoid setting the main and port relief valves at the same pressure setting. If these relief-valve settings are set too close, interaction will occur causing chatter and possible instability of the load.

The pilot-operated, port relief (Fig. 8) with the anticavitation check can be used in all hi-boy work sections in the VA20/VG20, VA/VG35 and VG80 series. The differential-area, work-port, relief valve (Fig. 9) can be used in VA20/VG20, VA/VG35 hi-boy sections if the section has the appropriate machining.

Service Parts List for Figure 8-10

Item	Description	Qty.	Part No.
1	O-ring	1	391-2881-333
2	Back-up Ring	1	391-2681-510
3	O-ring	1	391-2881-204
4	O-ring	1	391-2881-246
5	O-ring	1	391-2881-801
6	O-ring	1	391-2881-363
7	Shims	-	See chart below

*All seals in the relief cartridge are not serviceable.

Shims for Figure 10

Part No.	Pressure
391-3782-103	502 psi
391-3782-104	122 psi
391-3782-105	40 psi

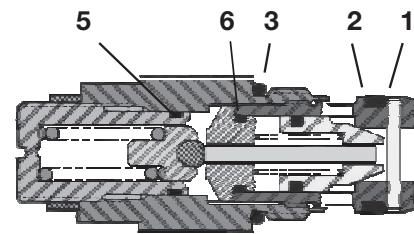

Pilot operated with anti-cavitation
355-9001-115

Figure 8

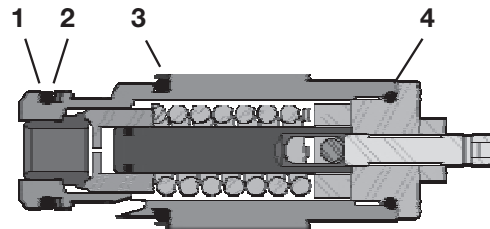

Differential area - screw adjusted
355-900X-308

Figure 9

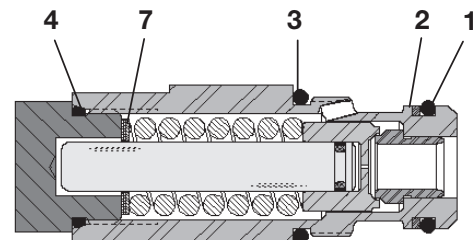

Differential area - shim adjusted
355-900X-143

Figure 10

NOTE: WHEN INSTALLING RELIEF VALVE, TORQUE TO 75 FT. LBS.

Screw-Adjustable, Relief-Valve Pressure Ranges and Adjustments

R/V #	Valve Series	Pressure Range - PSI	1/2 Turns Part Equals PSI*
355-9107-035	VA/VG20	800 - 2500	165
355-9001-061	VA/VG20	2501 - 3800	160
355-9107-013	VA/VG35	800 - 2000	80
355-9107-082	VA/VG35	2001 - 2500	121
355-9107-385	VA/VG35	2501 - 3500	249
355-9001-008	VG80	1000 - 2500	196
355-9001-031	VG80	2500 - 3500	290
355-9001-115	VA/VG20, 35, 80	500 - 5000	446
355-9001-308	VA/VG20, 35, 80	500 - 1250	95
355-9002-308	VA/VG20, 35, 80	1251 - 2650	138
355-9003-308	VA/VG20, 35, 80	2651 - 4200	188

*Adjustment pressures are approximate.

Guidelines for Setting Hydraulic, Relief-Valve Pressure:

- Release hydraulic pressure before connecting or disconnecting any gauge.
- Install an accurate pressure gauge as close to the pump as possible.
- Back-out the relief-valve adjustment screw without removing it.
- Warm the hydraulic oil by idling the engine with the power take-off and hydraulic pump engaged.
- As applicable, fully engage the control valve for the circuit being tested. Allow the cylinder to reach full extension.
- Raise the engine RPM to operating speed.
- If adjustment is necessary, do not bring the pressure to a higher setting then lower it to the desired setting. Obtain each final pressure by bringing the pressure gradually up to the proper setting.
- Tighten the lock nut and apply a sealant to avoid tampering.

 **WARNING**

Relief-valve pressures should be set according to the original, equipment manufacturer's specifications. Exceeding the specifications could cause a failure in the hydraulic system or with the mechanical structure of the equipment. These failures could cause serious personal injury or death.

DVA20 - DVG20 - VA20 - VG20 - Valve Seal Kits

Part Number	Kit Description	Application / Where Used
391 1873 035 391 1803 055	Section Seal Kit (Between Sections)	Inlet Sections Parallel and Tandem Worksections Midsection Inlet
391 1873 083	Section Seal Kit (Between Sections)	Series Worksections
391 1873 036 391 1803 457	Work Section Repair Kit (All Seals)	Manual, Parallel, and Tandem Worksections
391 1803 846	Spool Seal Kit	Standard Manual Worksections
391 1873 039 391 1803 469	Main-Relief Seal Kit (All Serviceable Seals)	391 1873 001, 391 1873 128 355 9107 035, 355 9001 061
391 1803 674	Main-Relief, Plug Seal Kit Convertible-Outlet, Plug Seal Kit	391 1873 002
391 1873 042 391 1803 737	Screw Adjusted, Pilot-Operated, Port Relief Valve with Anti-Cavitation Seal Kit (All Serviceable Seals)	391 1873 006, 355 9001 115
391 1823 038	Port-Accessory Seal Kit (External Seals Only)	391 1873 006 , 355 9001 115 391 1873 007, 008, 009 355 900X 143 391 1873 010 , 355 9001 164 391 1873 011 , 391 2283 075
391 1873 037 391 1823 122	Slug-Adjusted, Relief Valve Kit (All Serviceable Seals)	391 1873 007, 008, 009 355 900x 143
391 1873 207 391 1803 387	Pneumatic, Endcap Seal Kit (New Commercial Intertech Design)	391 1873 206 , 391 1803 553
391 1803 694	Pneumatic, Endcap Seal Kit (Old RMH Design)	391 1873 022 , 391 1803 606 391 1803 767

Note: Part numbers in bold are distributor program items.

DVA20 - DVG20 - VA20 - VG20 - Handle Assemblies

Part Number	Kit Description	Application / Where Used
3911873061	DV20-H-6	VA/VG20 6"
3911873062	DV20-H-8	VA/VG20 8"
3911873063	DV20-H-10	VA/VG20 10"
3911873064	DV35-H-6	VA/VG35 6"
3911873065	DV35-H-8	VA/VG35 8"
3911873066	DV35-H-10	VA/VG35 10"

DVA35 - DVG35 - VA35 - VG35 - Valve Seal Kits

Part Number	Kit Description	Application / Where Used
391 1873 040 391 1803 093	Section Seal Kit (Between Sections)	Inlet Sections Parallel and Tandem Work Sections Combined-Flow, Midsection Inlets Midsection Selectors
391 1803 150	Section Seal Kit (Between Sections)	Series Work Sections Split-Flow, Midsection Inlets
391 1873 041 391 1803 722	Work Section Repair Kit (All Seals)	Manual, Parallel, and Tandem Work Sections
391 1823 121	Work Section Repair Kit (All Seals)	Manual, Series Work Sections
391 1823 146	Work Section Repair Kit (All Seals)	Remote, Parallel, and Tandem Worksections
391 1873 044 391 1803 272	Main Relief-Valve Seal Kit (All Serviceable Seals)	391 1873 003 , 355 9107 013 391 1873 004 , 355 9107 085 391 1873 137 , 355 9107 385
391 1803 682	Main Relief-Valve Plug Seal Kit Convertible-Outlet, Plug Seal Kit	391 1873 005
391 1873 042 391 1803 737	Screw Adjusted, Pilot-Operated, Port Relief Valve with Anti-Cavitation Seal Kit (All Serviceable Seals)	391 1873 006 , 355 9001 115
391 1823 038	Port-Accessory Seal Kit (External Seals Only) 391	391 1873 006 , 355 9001 115 391 1873 007, 008, 009 355 900X 143 391 1873 010 , 355 9001 164 391 1873 011 , 391 2283 075
391 1873 037 391 1823 122	Slug-Adjusted, Relief Valve Kit (All Serviceable Seals)	391 1873 007, 008, 009 355 900X 143
391 1873 207 391 1803 387	Pneumatic Endcap Seal Kit (New Commercial Intertech Design)	391 1873 203 , 391 1803 554
391 1803 695	Pneumatic Endcap Seal Kit (Old RMH Design)	391 1873 203 , 391 1803 591
391 1823 121	Work Section Repair Kit (All Seals)	Series Work Sections

DVG80 - VG80 Valve Seal Kits

Part Number	Kit Description	Application / Where Used
391 1873 160 391 1803 484	Section Seal Kit (Between Sections)	Inlet Sections All Work Sections
391 1873 161 391 1803 594	Work Section Repair Kit (All Seals)	Manual Work Sections
391 1823 101	Main, Relief-Valve Seal Kit (All Serviceable Seals)	355 9001 008, 031
391 1803 041	Main, Relief-Valve Seal Kit (External Seals)	355 9001 008, 031
391 1803 054	Main, Relief-Valve and Plug Seal Kit (External Seals)	391 1873 146 , 391 1873 147 355 9001 103
391 1803 770	Main, Relief-Valve Seal Kit (All Serviceable Seals)	391 1873 146 , 355 9001 103
391 1873 042 391 1803 737	Screw-Adjusted, Pilot-Operated, Port Relief Valve with Anti-Cavitation Seal Kit (All Serviceable Seals)	391 1873 006 , 355 9001 115
391 1823 038	Port Accessory Seal Kit (External Seals Only)	391 1873 006 , 355 9001 115 391 1873 011 , 391 2283 075 391 1873 010 , 355 9001 164
391 1823 175	Work Section Repair Kit (All Seals)	Hydraulic-Remote Operated

Note: Part numbers in bold are distributor program items.

Trouble	Probable Cause	Remedy
Oil leaks between sections	Pinched, blown or missing section seal	Replace section seal
	Stud fasteners not correctly torqued	Replace section seals and re-torque
	Mounting plate not level	Loosen mounting bolts and shim as required
	Contamination/burrs on seal	Clean seal groove, replace section seal
Oil leaks at either end of spool	Over-pressurized tank core	Correct high, back-pressure condition
	Worn or damaged spool seal	Replace seals and seal retainers
Spring - centered spools do not return to neutral	Broken centering spring	Replace centering spring
	Misalignment of operating linkage	Check linkage for mechanical binding
	Foreign particles in system	Clean valve and system
Load will not hold	Cylinder leaking or worn	Check cylinder - repair
	Port relief valve not holding	Remove and clean or replace
	Spool or housing scored or worn excessively	Replace section
Load drops when spool moved from neutral	Dirt or foreign particles lodged between check-valve poppet and seat	Disassemble, clean & reassemble
	Scored or sticking check-valve poppet	Replace poppet
No motion, slow, or erratic system operation	Worn pump	Check flow & pressure
	Defective cylinder or motor	Repair or replace
	Low-reservoir oil level	Add oil to specifications
	Clogged suction strainer	Clean or replace
	Suction line restricted	Check lines
	Relief valve not properly set	Check pressure setting
	Relief valve poppet or seat scored & sticking open	Replace relief valve
Valve spool not shifted to full stroke	Check spool linkage travel	



Parker Safety Guide for Selecting and Using Hydraulic Valves and Related Accessories

WARNING: Failure or improper selection or improper use of Parker Hydraulic Valve Division (HVD) Valves or related accessories ("Products") can cause death, personal injury and property damage. Possible consequences of failure or improper use of these Products include but are not limited to:

- Valves or parts thereof thrown off at high speed
- High velocity fluid discharge
- Explosion or burning of the conveyed fluid
- Contact with suddenly moving or falling objects controlled by the Valve
- Injections by high-pressure fluid discharge
- Contact with fluid that may be hot, cold, toxic or otherwise injurious
- Injuries resulting from injection, inhalation or exposure to fluids
- Injury from handling a heavy item (dropped, awkward lift)
- Electric shock from improper handling of solenoid connections
- Injury from slip or fall on spilled or leaked fluid

Before selecting or using any of these Products, it is important that you read and follow the instructions below. In general, the Products are not approved for in-flight aerospace applications. Consult the factory for the few that are FAA approved.

1.0 GENERAL INSTRUCTIONS

- 1.1 **Scope:** This safety guide provides instructions for selecting and using (including assembling, installing and maintaining) these Products. For convenience all items in this guide are called "Valves". This safety guide is a supplement to and is to be used in conjunction with the specific Parker catalogs for the specific Valves and/or accessories being considered for use. See item 1.6 below for obtaining those catalogs.
- 1.2 **Fail-Safe:** Valves can and do fail without warning for many reasons. Design all systems and equipment in a fail-safe mode, so that failure of the Valve or Valve Assembly will not endanger persons or property.
- 1.3 **Safety Devices:** Never disconnect, override, circumvent or otherwise disable any safety lockout on any system whether powered by HVD Valves or any motion control system of any manufacturer. (e.g. Automatic shut-off on a riding lawn mower should the operator get out of the seat).
- 1.4 **Distribution:** Provide a copy of this safety guide to each person that is responsible for selecting or using HVD Valve Products. Do not select HVD Valves without thoroughly reading and understanding this safety guide as well as the specific Parker catalogs for the Products considered or selected.
- 1.5 **User Responsibility:** Due the wide variety of operating conditions and applications for Valves, HVD and its distributors do not represent or warrant that any particular Valve is suitable for any specific system. This safety guide does not analyze all technical parameters that must be considered in selecting a product. The user, through its own analysis and testing is solely responsible for:
 - Making the final selection of the Valve
 - Assuring that the user's requirements are met and that the application presents no health or safety hazards.
 - Providing all appropriate health and safety warnings on the equipment on which the Valves are used.
 - Assuring compliance with all applicable government and industry standards.
- 1.6 **Additional Questions:** Call the appropriate Parker technical service department if you have any questions or require any additional information. See the Parker publication for the product being considered or used, or call 1-800-CPARKER, or go to www.parker.com, for the telephone numbers of the appropriate technical service department. For additional copies of this or any other Parker Safety Guide go to www.parker.com and click on the safety button on the opening page. Catalogs and/or catalog numbers for the various HVD Valve Products can be obtained by calling HVD at 440-366-5100. Phone numbers and catalog information is also available on the Parker website, www.parker.com.

2.0 VALVE INSTRUCTIONS

- 2.1 **Pressure:** Valve selection must be made so that the maximum working pressure of the Valve is equal to or greater than the maximum system pressure. Surge, impulse or peak transient pressures in the system must be below the maximum working pressure of the Valve. Surge, impulse and peak pressures can usually be determined by sensitive electrical instrumentation that measures and indicates pressures at millisecond intervals. Mechanical pressure gauges indicate only average pressure and cannot be used to determine surge, impulse or peak transient pressures. Burst pressure ratings if given or known are for manufacturing purposes only and are not an indication that the Product can be used in applications at the burst pressure or otherwise above the maximum working pressure.
- 2.2 **Temperature:** The fluid temperature must be regulated or controlled so that the operating viscosity of the fluid is maintained at a level specified for the particular Valve product. Such ranges are given in the product catalogs or can be obtained from the appropriate customer service department for the particular Valve product.
- 2.3 **Fluid Compatibility:** The fluid conveyed in Valves has direct implications on the Valve selection. The fluid must be chemically compatible with the Valve component materials. Elastomer seals, brass, cast iron, aluminum for example all are potentially affected by certain fluids. Additionally, fluid selection affects the performance of various Valves. Considerations relative to fluid selection are outlined in the specific HVD Valve product catalog. Of particular importance is that the fluid be for hydraulic use, contain the proper additives and wear inhibitors. See 1.6 "Additional Questions" above for information to obtain such HVD catalogs.
- 2.4 **Changing Fluids:** If a system requires a different fluid, it should be done with the guidance in number 2.3 above. Additionally, it may be necessary to flush the system (including the Valves) to remove any of the previous fluid. Consult the Parker Valve Division for guidance.
- 2.5 **Size:** Transmission of power by means of pressurized fluid varies with pressure and rate of flow. The size of the components must be adequate to keep pressure losses to a minimum and avoid damage due to heat generation or excessive fluid velocity.
- 2.6 **Placement:** Installation of Valves must take into account the orientation of the Valve and the proximity of the Valve to other parts of the system. This includes but is not limited to closeness to hot and cold areas, access for servicing and operation as well as orientation for proper connectors.
- 2.7 **Ports:** Connection of Valves in systems can be by threaded ports, sub-base surfaces, flanges and manifolds. In all cases, the proper fitting, surface or mounting hardware must be selected to properly seal and contain the system fluid so as to avoid the adverse conditions listed in the initial warning box above. Specifically, if using threaded ports, the designer must make sure that the mating fitting is of the compatible thread. Also, the instructions provided by the connector hardware supplier must be read and understood so as to properly assemble the connector. The Parker Safety Guide for using Hose, Tubing and Fittings and Related Accessories is but one reference to this end.
- 2.8 **Environment:** Care must be taken to insure that the Valve and Valve Assemblies are either compatible with or protected from the environment (that is, surrounding conditions) to which they are exposed. Environmental conditions including but not limited to ultraviolet radiation, sunlight, heat, ozone, moisture, water, salt water, chemicals and air pollutants can cause degradation and premature failure.
- 2.9 **Electric Power:** For Valves requiring electric power for control, it is imperative that the electricity be delivered at the proper voltage, current and wattage requirements. To obtain the proper control requirements please refer to the respective Parker product catalog for the specific Valve that is intended for use. If further guidance is required, call the appropriate technical service department identified in the respective Parker product catalog.
- 2.10 **Specifications and Standards:** When selecting Valves, government, industry and Parker specifications and recommendations must be reviewed and followed as applicable.
- 2.11 **Accessories:** All accessories used in conjunction with any Parker Valve product must be rated to the same requirements of the Valve including but not limited to pressure, flow, material compatibility, power requirements. All of these items must be examined as stated in the "VALVE INSTALLATION INSTRUCTIONS" paragraph 3.0.

(continued on next page)

3.0 VALVE INSTALLATION INSTRUCTIONS

- 3.1 **Component Inspection:** Prior to use, a careful examination of the Valve(s) must be performed. The Valve intended for use must be checked for correct style, size, catalog number and external condition. The Valve must be examined for cleanliness, absence of external defects or gouges, cracked or otherwise deformed parts or missing items. The mounting surface or port connections must be protected and free of burrs, scratches, corrosion or other imperfections. Do NOT use any item that displays any signs of nonconformance. In addition, any accessory including but not limited to fittings, bolt kits, hoses, sub bases, manifolds, and electrical connectors must be subjected to the same examination.
- 3.2 **Handling Valves:** Many Valves whether HVD Valves or of another manufacturer can be large, bulky or otherwise difficult to handle. Care must be taken to use proper lifting techniques, tools, braces, lifting belts or other aids so as not to cause injury to the user, any other person or to property.
- 3.3 **Filtration:** Fluid cleanliness is a necessity in any hydraulic system. Fluid filters must be installed and maintained in the system to provide the required level of fluid cleanliness. Filters can be placed in the inlets, pressure lines and return lines. The level of cleanliness required is specified in the HVD product catalog for the specific Valve(s) selected or intended for use. For additional information on Filter selection contact Parker Filter Division at 800-253-1258 or 419-644-4311.
- 3.4 **Servo Valves:** Application of Servo Valves in general requires knowledge and awareness of "closed loop control theory" and the use of electronic controls for successful and safe operation. Individuals who do not have such experience or knowledge must gain training before use of such Products. Parker offers both classroom training as well as manuals to assist in gaining this knowledge. These aids can be obtained by contacting Hydraulic Valve Division at 440-366-5100, calling the general Parker help line 800-CPARKER or going to the Parker web site at www.parker.com.
- 3.5 **Accessory Ratings:** All accessories used in combination with the selected or intended Valve product must be rated and compatible with the selected Valve. Specifically, the items must be of equal or greater rating including but not limited to pressure, flow, power, size, port style, thread connectors and material.
- 3.6 **Connection Styles:** It is the responsibility of the user of the Parker product to properly select connectors and accessories that match the connections on the sub plate, Valve, flange or threaded connection or manifold. It is also the responsibility of the installer to possess adequate skill and knowledge including but not limited to thread preparation, torque technique, hose assembly and inspection, tube preparation and assembly, and fitting installation. Parker Tube Fitting Division (www.parker.com/tfd) catalog 4300 and Parker Hose Products (www.parkerhose.com) catalog 4400 describe some basic technical information relative to proper fitting assembly.
- 3.7 **Electrical Connections:** All electrical connections must be made to the applicable codes and local safety requirements.
- 3.8 **Gauges and Sensors:** The user must install sufficient gauges and sensors in the system so as to be able to determine the condition of the system. This includes but is not limited to pressure gauges, flow meters, temperature sensors and site gauges. These are of utmost importance should removal or disassembly of a Valve, portion of a Valve or portion of the system become necessary. Refer to "VALVE MAINTENANCE AND REPLACEMENT INSTRUCTIONS" for details and especially item 4.8.
- 3.9 **System Checkout:** Once installed, the Valve installation must be tested to insure proper operation and that no external leakage exists. All safety equipment must be in place including but not limited to safety glasses, helmets, ear protection, splash guards, gloves, coveralls and any shields on the equipment. All air entrapment must be eliminated and the system pressurized to the maximum system pressure (at or below the Valve maximum working pressure) and checked for proper function and freedom from leaks. Personnel must stay out of potentially hazardous areas while testing and using.

4.0 VALVE MAINTENANCE AND REPLACEMENT INSTRUCTIONS

- 4.1 **Maintenance Program:** Even with proper installation, Valves and Valve System life may be significantly reduced without a continuing maintenance program. The severity of the application and risk potential must determine the frequency of the inspection and the replacement of the Products so that Products are replaced before any failure occurs. A maintenance program must be established and followed by the user and, at a minimum, must include instructions 4.2 through 4.10. An FMEA (Failure Mode and Effects Analysis) is recommended in determining maintenance requirements.
- 4.2 **Visual Inspection-Valves:** Any of the following conditions require immediate shut down and replacement of the Valve.
- Evidence that the Valve is in partial dis-assembly.
 - Visible crack or suspicion of a crack in the Valve housing or bent, cracked or otherwise damaged solenoid.
 - Missing or partially extending drive pin on a flow control knob.
 - Missing, loose components, obstructions or other condition impeding the motion or function of the manual knob, lever, foot pedal or other mechanical operator of a hydraulic Valve.
 - Any evidence of burning or heat induced discoloration.
 - Blistered, soft, degraded or loose cover of any kind.
 - Loose wire or electrical connector.
- 4.3 **Visual Inspection-Other:** The following conditions must be tightened, repaired, corrected or replaced as required.
1. Fluid on the ground must be cleaned immediately. Also, the source of the fluid must be determined prior to running the equipment again.
 2. Leaking port or excessive external dirt build-up.
 3. System fluid level is too low or air is entrapped or visible in the reservoir.
 4. Equipment controlled by the Valve or Valve assembly has been losing power, speed, efficiency
- 4.4 **Filter Maintenance:** System filters must be maintained and kept in proper working order. The main service requirement is periodic replacement of the filter element or screen. Contact Parker Filter Division at 800-253-1258 or 419-644-4311 for further filter maintenance details.
- 4.5 **Functional Test:** See "System Checkout" number 3.9 above in "VALVE INSTALLATION INSTRUCTIONS".
- 4.6 **Replacement Intervals:** Valves and Valve Systems will eventually age and require replacement. Seals especially should be inspected and replaced at specific replacement intervals based on previous experience, government or industry recommendations, or when failures could result in unacceptable downtime, damage or injury risk. At a minimum seals must be replaced whenever service is rendered to a Valve product.
- 4.7 **Adjustments, Control Knobs, and Other Manual Controls:** System Pressure and Flow are typically adjusted by knobs and/or handles. A set-screw or lock-nut secures the adjustment device so as to maintain the desired setting. This set-screw or lock-nut must first be loosened prior to making any adjustments and re-tightened after adjustment on the HVD Valve. All adjustments must be made in conjunction with pressure gauges and/or flow meters (or by watching the speed of the actuator in the case of setting flow only). See paragraph "Gauges and Sensors" above in the section "VALVE INSTALLATION INSTRUCTIONS". Under no circumstances should any control knob, adjustment stem, handle, foot pedal or other actuating device be forced beyond the mechanical stop(s) on the Valve. For example, the Parker Safety Notice Bulletin **HY14-3310-B1/US** for HVD Colorflow Valves specifically restricts the adjustment torque to "hand adjust" or "less than 10 ft/lbs" if it cannot be adjusted by hand. Failure to adhere to this may force the knob beyond the stop point allowing it to be ejected at high speed resulting in death, personal injury and property damage. For complete safety instructions on HVD Colorflow Valves, copies of Safety Notice Bulletin **HY14-3310-B1/US** can be obtained directly from the Hydraulic Valve Division at 440-366-5100 or from the Parker web site at www.parker.com by selecting the "Safety" button. Parker help line 800-CPARKER is on call 24/7 as well should there be any question about the use of a HVD Valve. Additionally, when making adjustments, always adjust the Valve with all parts of your body to the side of the Valve (that is, the knob is not pointing toward you or anyone else).
- 4.8 **High pressure Warning:** Hydraulic power is transmitted by high-pressure fluids through hoses, fittings and valves, pumps and actuators. This condition can be dangerous and potentially lethal and, therefore, extreme caution must be exercised when working with fluids under pressure. From time to time, hoses, Valves, tubes or fittings fail if they are not replaced at proper time intervals. Typically these failures are the result of some form of misapplication, abuse, wear, or failure to perform proper maintenance. When such failure occurs, generally the high pressure fluid inside escapes in a stream which may or may not be visible to the user. Under no circumstances should the user attempt to locate the leak by "feeling" with their hands or any other part of their body. High-pressure fluids can and will penetrate the skin and cause severe tissue damage and possible loss of limb or life. Even seemingly minor hydraulic fluid injection injuries must be treated immediately by a physician with knowledge of the tissue damaging properties of hydraulic fluid. If a hose, tube, fitting or Valve failure occurs, immediately shut down the equipment and leave the area until pressure has been completely released from the system. Simply shutting down the pump may or may not eliminate the pressure in the system. It may take several minutes or even hours for the pressure to be relieved so that the leak area can be examined safely. Once the pressure has been reduced to zero, the suspected leaking item can be taken off the equipment and examined. It must always be replaced if a failure has occurred. Never attempt to patch or repair a connector (especially a hose) or Valve that has failed. Consult the nearest Parker distributor or the appropriate Parker division for component replacement information. Never touch or examine a failed hydraulic component unless it is obvious that the item no longer contains fluid under pressure.



Parker Hannifin
Hydraulic Valve Division
520 Ternes Lane
Elyria, Ohio United States 44035
Ph: (440) 366 5100
Fax: (440) 366 5253
hvdsales@parker.com
www.parker.com/hydraulicvalve