

2018 Catalog



Trihal

Cast resin transformer up to 36kV

Distribution Transformers

Contents

Presentation 4

Technology 20

Product description 26

Options and accessories 34

Tests and specifications 44

Digital tools 52

Annex 60

Presentation

Presentation

Your requirements	6
Our solution	7
The experience of a world leader	8
Protecting the environment	10
Quality assurance	11
EcoStruxure™ Ready solutions	12
EcoStruxure™ Facility Expert	14
EcoStruxure™ Asset Advisor	15
Setting new standard	16
Basic equipment	17
Technology and construction	17
Type and range	17
Environmental protection	17
Technology and construction	18
Standards and configurations	18

Your requirements

Safety



Reliability



Connectivity



Flexibility



Trihal is a best-in-class range of dry-type cast resin transformers renowned for its safety, efficiency and reliability.

Trihal is a best-in-class range of dry-type cast resin transformers renowned for its safety, efficiency and reliability. With a worldwide installed base of over 150 000 units in more than 100 countries, Trihal is an optimized transformer for contractors, panel-builders and distributors from the mid and large sized buildings and industry to the renewables and electro-sensitive/intensive applications. With more than 30 years of manufacturing experience, Trihal is engineered to minimize customer's total cost of ownership and best return on investment for a dry transformer.



High safety and reliability

Unrivalled performance

C3 E3 and F1 certificates:

- Rigorous climatic, environmental and fire safety testing confirms optimal performance even in harsh conditions (min -50 °C & 95% humidity)
- <5pC to reduce the insulation ageing due to electrical field

Efficient connected monitoring

Ecostruxure™ Ready

Discover performance inefficiencies early and switch to predictive maintenance, saving time, money and minimizing transformer downtime.

Easy selection

MV business accelerator

- Quick configuration and quotes
- Rapid ordering and delivering tracking
- Fast and fixed delivery

Green Premium ecomark

Certified with our Green Premium ecomark indicating compliance with environmental regulations, including RoHS, REACH, PEP, and EoLI.

The experience of a world leader

The Schneider Electric experience's extends over 35 years in factory-built Trihal cast resin technology transformer.

This experience means that today Schneider Electric can propose a comprehensive range of cast resin transformers to reinforce the safety of people according to the IEC standard.

This gives you the advantage of unique experience, that of a world leader, with over 150,000 Trihal units installed in more than 100 countries.

Putting this experience at your service and remaining attentive to your requirements is the spirit of active partnership that we want to develop in offering you the Trihal.

Trihal cast resin technology transformer has a twenty years lifetime.

These transformers have a full range of accessories and allow you to adapt to all your Medium Voltage installation requirements up to 36kV.

The result of in-depth analysis of your requirements, both now and in the future, Trihal transformers mean that you can take advantage of all the features of both a modern and proven technology.

Trihal world experience for your dedicated application:



Hospitals



Data centers



Food and beverage



Airports



Nuclear



Buildings



Mining, metal & minerals



Automotive



Wind



Oil and gas

Trihal over the years



1982 - Innovation:

First Trihal manufactured.

2000 - Experience:

Over 50,000 Trihal transformers equipped networks throughout the world.

2006 - Innovation and experience:

Increase robustness with extended warranty offer.

2015 - A leading position:

With over 150,000 Trihal transformers installed around the world.

2018 - Trihal EcoStruxure™ Ready:

Trihal is part of IoT experience.

Since its launch, Schneider Electric have manufactured more than 150,000 Trihal transformers which gives more than 4,000 a year.

DM105721

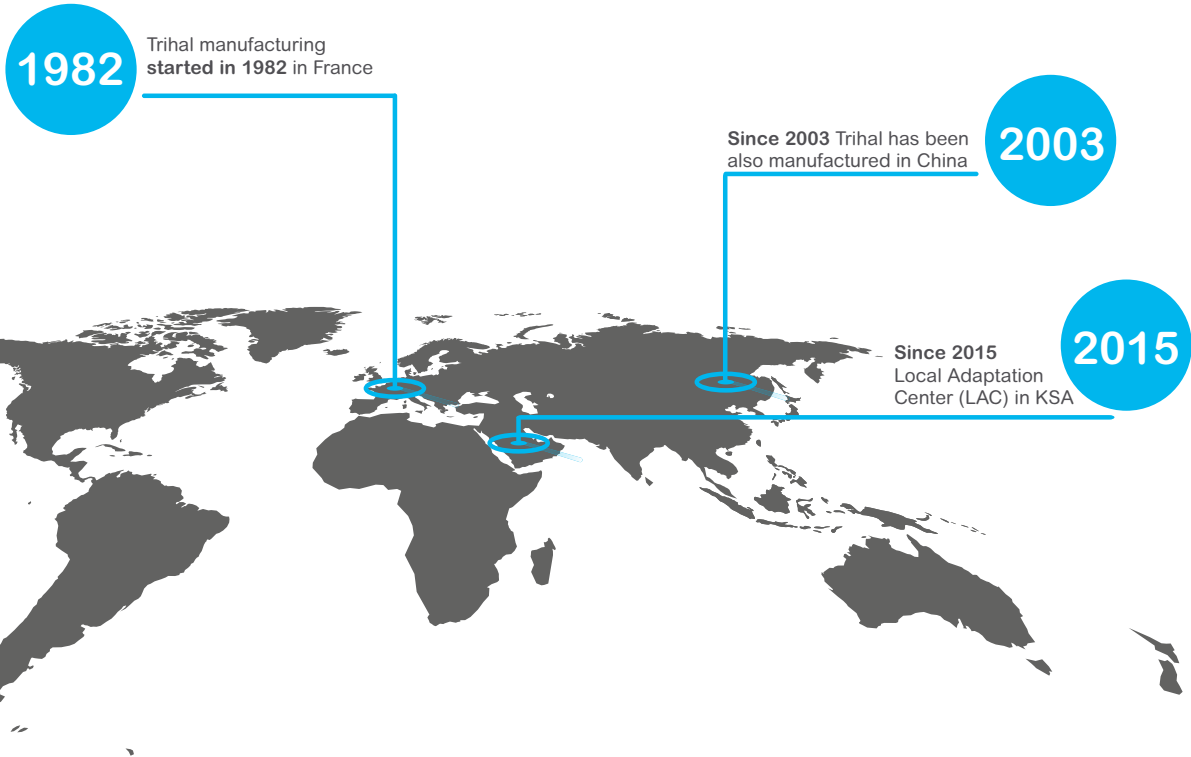

Schneider Electric's recycling service for Trihal products is part of a rigorous management process.

Environmental performance

Schneider Electric is committed to a long-term environmental approach.

All necessary measures have been taken in conjunction with our services, suppliers and subcontractors to ensure that the materials used in the composition of the equipment do not contain any substances prohibited by regulations and directives.

Schneider Electric's ambition is to reduce the environmental impact of its products throughout their whole life cycle, by offering end-of-life Trihal recycling solutions. Up to 84% of its equipment can be recycled for re-use.

Operations recommended for the end of life treatment

There are several steps to process the products at the end of life so as to recover components, materials or energy :

Reuse → Separation for special treatment → Other dismantling → Shredding

The components of the products that optimize the recycling performances are listed, identified and located in the drawing.

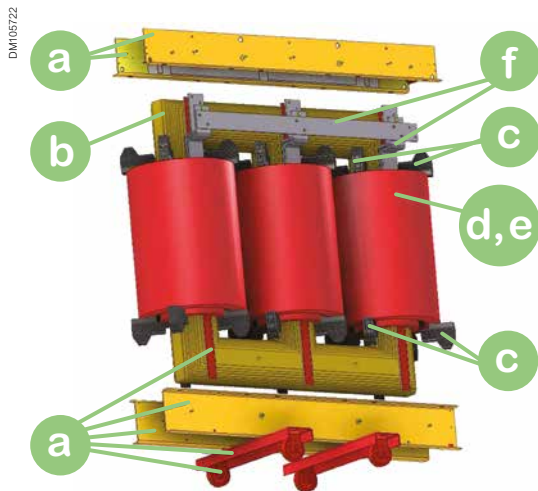

Recommendation	Drawing Ref	Components	Weight (in kg)	Comment
Dismantling	a	Steel parts	100~5000	Clampings, rollers
	b	Core	300~25000	Magnetic steel
	c	Plastic parts	30~250	Support wedges
	d	Resin	100~3500	Coil insulation
	e	Conductors	30~5000	Aluminium or copper
	f	Bars	20~100	Aluminium or copper

In Trihal transformers, there is no component which may effect on human health or environmental pollution during dismantling process.

Conductors (e) inside the coils are integrated with cast resin and need to be separated to be included in recycling process.



The environmental management system adopted by Schneider Electric production sites that produce the Trihal have been assessed and judged to be in conformity with requirements in the ISO 14001 and 50001 standards.



A major advantage

Schneider Electric has integrated a functional organisation into each of its units. The main mission of this organisation is to check the quality and the compliance with standards. This procedure is:

- Uniform throughout all departments
- Recognised by our customers and approved organisations.

But it is above all its strict application that has enabled recognition to be obtained by an independent organisation:

The French **Q**uality **A**ssurance **A**ssociation (**FQAA**).

The quality system for the design and manufacture of Trihal units has been certified in conformity with the requirements of the ISO 9001: 2000 quality assurance model.

Meticulous and systematic controls

During manufacture, each Trihal is subject to systematic routine testing which aims to grant highest quality and conformity:

- Induced voltage up to $2.5 U_n$ dielectric test
- Applied voltage dielectric test
- Measurement of no-load losses and no-load current
- Measurement of the resistance of the MV and LV windings
- Measurement of the transformation ratio and vector group
- Partial discharge measurement

The results obtained are written and reported on the test certificate for each device by the quality control department. Quality is the highest priority of Schneider Electric and to grant the best product for our customers, we also have in our manufacturing process an impulse test done randomly on samples picked in production.

Mean Time To Failure (MTTF)

As result of Schneider Electric quality assurance system, Trihal has negligible "Mean Down Time (MDT)" in comparison to the "Mean Up Time (MUT)".

[Mean Time to Failure \(MTTF\) - cumulative:](#)

Trihal MTTF = 3108 years - 0.09% of electrical failure



EcoStruxure™ ready solutions

What is EcoStruxure™?

450 000

EcoStruxure™ systems deployed since 2007 with the support of our 9 000 system integrators.

EcoStruxure™ ready



Efficient asset management
Greater efficiency with **predictive** maintenance helping to reduce downtime.



24/7 connectivity
Real-time data **everywhere anytime** to make better informed decisions.



Increased safety
Proven design and experience combined with fast **embedded arc detection** to enhance people's and equipment's safety.

EcoStruxure™ architecture and interoperable technology platform bring together energy, automation, and software. It provides enhanced value around safety, reliability, efficiency, sustainability, and connectivity.

Turn data into action

EcoStruxure™ architecture lets customers maximize the value of data.

Specifically, it helps them:

- Translate data into actionable intelligence and better business decisions
- Take informed decisions to secure uptime & operational efficiency thanks to real-time control platforms
- Get visibility to their electrical distribution by measuring, collecting, aggregating and communicating data

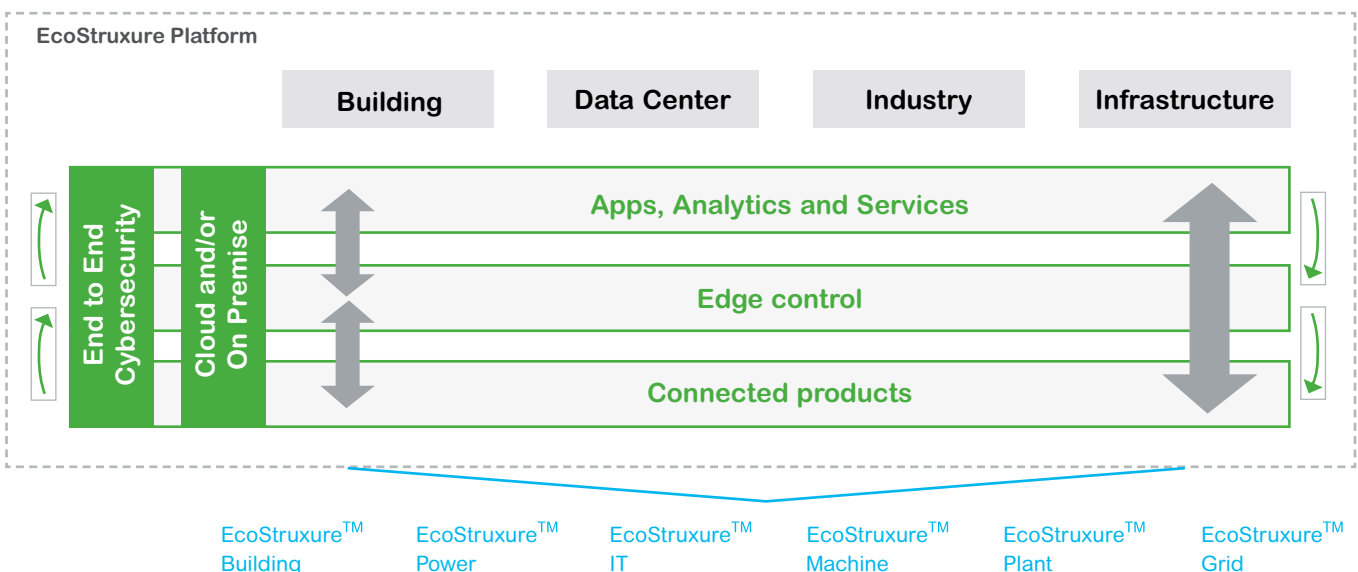
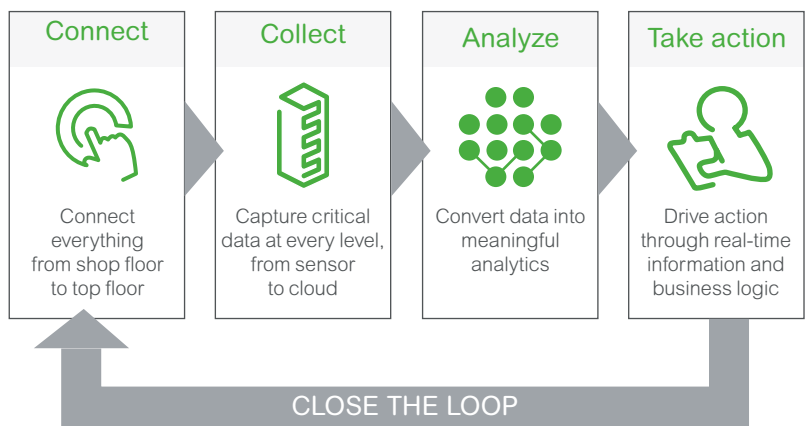

EcoStructure™ Ready solutions

Real-time condition monitoring to optimize assets availability

Easergy CL110 ambient monitoring

Schneider Electric ambient monitoring system will continuously:

- Help maintenance manager to avoid deterioration of the transformer due to moisture and pollution
- By automatically calculating the condensation cycle, and combining it with the declared mission profile conditions, the system will recommend maintenance and cleaning frequency adjustment in order to maintain the transformer in its nominal status

Easergy TH110 thermal monitoring

Easergy TH110 is part of the new generation of wireless smart sensors ensuring the continuous thermal monitoring of all the critical connections made on field allowing to:

- Prevent unscheduled downtimes
- Increase operators and equipments safety
- Optimize and predictive maintenance

Thanks to its very compact footprint and its wireless communication, Easergy TH110 allows an easy and widespread installation in every possible critical points without impacting the performance of the Trihal transformers.

By using Zigbee Green Power communication protocol, Easergy TH110 ensure a reliable and robust communication that can be used to create interoperable solutions evolving in the Industrial Internet of Things (IIoT) age.

Easergy TH110 is self powered by the network current and it can ensure high performances providing accurate thermal monitoring.

Click [here](#) to watch the video:

EcoStructure Ready
Distribution transformers

Characteristics

Power supply	Self powered. Energy harvested from power circuit.
Accuracy	+/- 1°C
Range	-25 °C / +115°C
Wireless communication	ZigBee Green Power 2,4 GHz
Dimension - Weight	31 x 31 x 13 mm - 15 g



TH110



TH110



CL110

EcoStruxure™ Facility Expert

Cloud software to improve operations efficiency

CGA3657



EcoStruxure™ Facility Expert

Optimize operations and maintenance, ensure business continuity and provide insight to service providers or facility managers.

Real time collaborative technology available on mobile devices or PCs, EcoStruxure™ Facility Expert remains managers and on field technicians connected to buildings and equipments and involves very simple information sharing between all users.

Register easily and overview all your assets status

QR code ready, Schneider Electric devices are already configured to communicate with EcoStruxure™ Facility Expert in a simple way and enable automatic download of ID, technical documentation and maintenance plan.

Located on the map, visualize all assets in real time, navigate and filter by area or status



Schneider Electric partners network

Schneider Electric local partners are trained and certified to sell, install and commission EcoStruxure™ Facility Expert.

They can also operate the solution if the site manager wants to delegate this task.



Improve maintenance operation

Providing relevant information on critical assets, sending instant and documented alarms EcoStruxure™ Facility Expert allows to diagnose remotely in case of issue and manage maintenance efficiently

- Instant alarms on threshold and status change
- Real-time assets status and map localization
- Maintenance plan, asset log history, asset doc repository
- Task manager and task reminder
- 1 clic to edit intervention and activity reports including voice memos, notes, photos and measurements
- Remain connected, comment, share information and get support in the field from colleague or expert if needed.

Click [here](#) to download the free version of
EcoStruxure Facility Expert

EcoStruxure™ Asset Advisor

Apps, analytics & services to improve operations efficiency

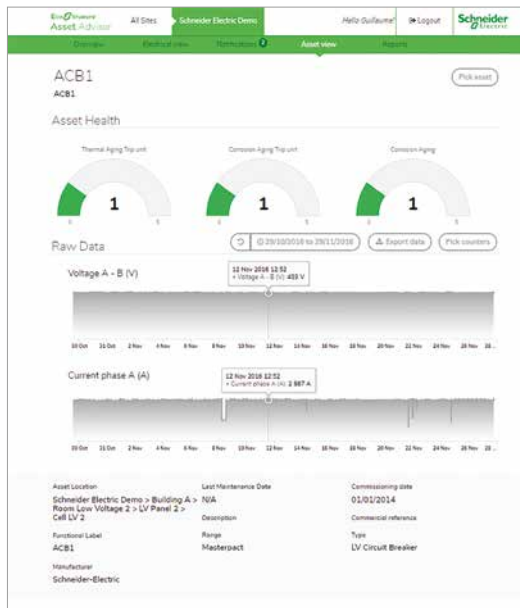

Asset Advisor Dashboard



Asset Health Matrix

Schneider Electric approach cybersecurity as a group...

- Data collected through secured gateways
- Secured data transport to prevent data access or manipulation
- Your data are hosted in Schneider Electric Data Center
- Results displayed on secured dashboard (reports, diagnostics, notifications...)
- You remain the owner of your data.

Click [here](#) to download the free version of **EcoStruxure Asset Advisor**

EcoStruxure™ Asset Advisor

Imagine having access to key data about your electrical distribution equipment whenever you need. And experienced professionals who help you make better informed decisions.

That's what you get with EcoStruxure Asset Advisor from Schneider Electric connected service.

You know exactly which assets need to be serviced or replaced. So you can better plan your expenses.

Are you...

- Planning to introduce Condition Base Maintenance (beyond corrective and regular maintenance) with benefits associated to reduced time to address an issue ?
- Looking for innovative solutions to scale their corporate reliability programs? Mostly started on rotatory machines before.
- Striving to dive into IoT complexity with actionable deliverables (not operational alarming)? Or get them defined by manufacturer.

Our EcoStruxure Asset Advisor solution

- Support your journey into predictive maintenance
- Designed for risk of failure mitigation and maintenance optimization
- Turning your data into short term actions and long term decisions
- Our platform is ready-to-use by plug-in connectable electrical assets under our flexible model.
- EcoStruxure Asset Advisor brings tangible benefits on failure risk mitigation and maintenance optimization.



Setting new standard



Trihal with and without enclosure

Setting a new standard for dry-type cast resin transformers

For a high level of safety and exceptional environmental friendliness, there's nothing to beat a dry-type cast resin transformer.

The epoxy resin insulation used in this kind of transformer means no oil is used, greatly reducing the risk of fire and improving recyclability, all without loss of performance compared to other transformer types. Dry-type cast resin transformers are therefore ideal for critical applications and high-traffic areas.

Even among dry-type cast resin transformers, Trihal from Schneider Electric stands out due to its outstanding performance and unrivalled certifications.

Trihal is a best-in-class range of dry-type cast resin transformers, rated from 160 kVA up to 15 MVA, with insulation rated up to 36 kV. It's perfectly suited to a wide variety of industries, from densely-populated buildings and critical infrastructure to heavy industry and renewable energy production.

Crucially, Trihal's safety and performance certifications are without equal, and the range is compliant with IEC60076-11 and IEC60076-16, as well as ISO 9001, ISO 14001 and OHSAS 18001.

All this results in optimum efficiency with very little maintenance, for a long service life.

Click [here](#) to discover our new enclosure offer: **Enclosure QI**

PMxxxx



Test lab

Technology and construction

Two HV winding technologies are available to fit to customer's needs: linear voltage gradient from top to bottom or "strip".

This technology developed by Schneider Electric has wide variety of applications and meets different customer requirements.

Type and range

Trihal is a three-phase dry-type transformer cast under vacuum in epoxy resin with an active filler.

This active filler, composed of alumina trihydrate, is the origin of the Trihal trademark.

Trihal transformers are supplied with or without an enclosure and from 160 kVA to 15 MVA and up to 36 kV.

PMxxxx



Assembly line

Environmental protection

The Trihal competence center was the first French facility to be certified ISO 14001 in this sector, and has been since 1998.

Trihal is designed and manufactured to be environmentally-friendly, providing an ecological solution for HV/LV transformers.

Environmental protection is integrated in our management systems in order to promote the protection of all natural resources and continuously improve conditions for a clean environment.

The product design focuses on minimizing its environmental impact.

Standards and configurations

	Standard design	Possible adaptation
Manufacturing standards	IEC 60076-11, EN 50588, EN 50629	GOST-R, BS, IEEE
Efficiency (losses level)	Eco-Design	Every reduced losses required by customers
Class tests	C3*, E3, F1, ≤ 5 pC	
HV/LV coils	HV encapsulated in cast resin/LV impregnated	HV and LV encapsulated in cast resin
Installations	Indoor use: <ul style="list-style-type: none"> IP00 (without enclosure)/IP31 (with enclosure) C2 Corrosivity class, Medium durability (in compliance with ISO 12944-6) 	Outdoor use with properly designed enclosure: <ul style="list-style-type: none"> From IP35 up to IP44 (with enclosure) Up to C5-Marine, Medium durability (in compliance with ISO 12944-6)
Winding material	According to manufacturer optimization (Cu or Al)	Cu/Cu
Phases	Three-phase	Single-phase
Cooling system	Standard: <ul style="list-style-type: none"> AN (natural air) Option: <ul style="list-style-type: none"> AF (air forced) 40% performance reserves 	AFWF (air forced water forced)
Maximum T°C/altitude	40°C at any time/1000 m	Up to 65°C/Above 1000 m
Thermal class insulation	According to IEC 60085, Class F	
Temperature rise	100 K	80 K (for 40°C) Temperature rise adapted to maximum T°C Temperature Rise < 100K upon request
Rated frequency	50 Hz or 60 Hz	
Rated power	Up to 3150 kVA	Up to 15 MVA
Impedance voltage Uk	From 4 to 6%	<ul style="list-style-type: none"> Lower than 4% Higher than 6% - Up to 11%
Vector groups	Dyn, YNd	All others according to IEC
Rated HV insulation	Up to 36 kV (IEC)	Up to 40.5 kV (GOST-R)
HV tapping	Off-circuit tapping links: 3 or 5 positions, +/- 2.5%	Off-circuit tapping links: up to 9 positions, +/- 2.5% or higher On Load Tap Changing (OLTC)
HV terminals	Standard HV connections	HV/MV plug-in or porcelain bushings through dedicated cable boxes (IEC, BS or NEMA compliant)
Rated LV (MV) insulation	1.1 kV	Up to 7.2 kV
LV terminals	<ul style="list-style-type: none"> Standard LV connections Top or bottom entry (on request) 	<ul style="list-style-type: none"> LV cable ducting interface (Canalis) Side entry through dedicated cable boxes (IEC, BS or NEMA compliant)
Thermal protection	<ul style="list-style-type: none"> AN cooling system: 6 PTC sensors (or 3 PT100) + Thermal Relay AF cooling system: 6 PT100 sensors (or 9 PTC) + Thermal Relay 	

Standards and configurations

	Standard design	Possible adaptation
Accessories	<ul style="list-style-type: none"> Standard: 4 bi-directional flat rollers, 4 lifting holes (depending of IP protection), 4 carriage holes on the sub-base, 2 earthing points, rating plate Most common options: Anti-vibration pads, remote communication for thermal relay, marshalling box, earthing ball, surge arresters 	Locking device for plug-in bushings, current transformers, automatic voltage regulator panel, On Load Tap Changer (OLTC), special paint color for enclosure
Test certificate	Routine tests: in accordance with IEC 60076-11	<ul style="list-style-type: none"> Type tests: in accordance with IEC 60076-11: temperature rise test, lightning impulse test Special tests: in accordance with IEC 60076-11: noise level measurement, short-circuit test Others: seismic test resistance, climatic, environmental or fire class tests

Technology

Technology

Manufacturing process	22
Magnetic core	22
LV winding	22
HV winding	23
HV casting system	23
HV coil casting process	24
HV support wedges	24

Control of the industrial process: very low partial discharge rate (≤ 5 pC).

Magnetic core

The magnetic core is made from laminated grain-oriented silicon steel.

The choice and grade of steel and the cutting pattern and method of assembly minimize the loss level and the no-load current, resulting in a very low noise level.

Once assembled, it is protected against corrosion.

LV winding

Additionally, HV winding can also be wound from insulated by an inter-layer film, pre-impregnated with heat-activated epoxy resin.

The ends of the windings are protected and insulated using end packing made of Class F materials.

The whole winding is polymerized by being placed in an autoclave at 130°C, which guarantees:

- outstanding resistance to harsh industrial atmospheres
- excellent dielectric withstand
- very good resistance to radial stress under short-circuit conditions

Each LV winding ends in a tin-plated aluminum or copper connection point, enabling connections to be made without using a contact interface.

PM105914

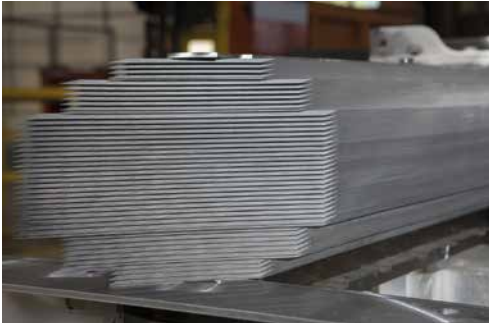

Magnetic core being assembled

PM106607



LV winding with foil technology

PM105916



HV winding with strip technology

HV winding

The HV winding is usually wound of aluminium or copper foils using "strip" technology.

The HV winding is usually wound from insulated aluminum or copper wire, using a method developed and patented by Schneider Electric: "a linear voltage gradient from top to bottom". These methods are used to obtain very low stress levels between adjacent conductors.

This winding is casted and molded under vacuum using Class F filling and fireproofed resin: the Trihal casting system.

These processes give coils very high dielectric properties with very low partial discharge level (guaranteed $\leq 5 \text{ Pc}$)⁽¹⁾ which is a decisive factor in influencing the transformer's life span and its lightning impulse withstand⁽²⁾.

HV tapping points on the copper connection bars enable connections to be made without using a contact interface (grease, bi-metallic strip).

PM105917



HV casting process

HV casting system

The system provides a vacuum-cast coating of fire-resistant filled resin, a technology developed and patented by Schneider Electric.

The Class F casting system comprises:

- A bisphenol-based epoxy resin with sufficient viscosity to ensure excellent impregnation of the windings
- An anhydride hardener ensures very good thermal and mechanical properties. A flexibilizing additive gives the casting system the necessary elasticity to prevent cracking during operation
- An active powdered filler consisting of silica and especially of alumina trihydrate thoroughly mixed with the resin and the hardener
- Silica, which reinforces the casting's mechanical strength and improves heat dissipation.

The alumina trihydrate guarantees the Trihal transformer's intrinsic fire performance. Alumina trihydrate produces 3 fire-retardant effects which occur in the event of calcination of the casting system (when the transformer is exposed to flames).

- 1st fire-retardant effect: refracting shield of alumina
- 2nd fire-retardant effect: barrier of water vapor
- 3rd fire-retardant effect: temperature held below the fire point

The result of all 3 fire-retardant effects is immediate self-extinguishing of the Trihal transformer.

In addition to its dielectric qualities, the casting system gives the Trihal transformer excellent self-extinguishing fire resistance and excellent environmental protection against harsh industrial atmospheres.

(1) Validated in external laboratory.

(2) It is important to note that the level of partial discharge remains the same throughout the transformer's service life.

HV coil casting process

The process, from proportioning the resin through to polymerization, is fully controlled by microprocessor, preventing any inopportune manual operation.

The alumina trihydrate and the silica are vacuum-dried and degassed to eliminate all traces of humidity and air which could degrade the casting system's dielectric characteristics.

Half is mixed with the resin and half with the hardener under hard vacuum and at a controlled temperature, to give two homogenous pre-mixes.

Another thin film degassing precedes the final mixing. Vacuum casting is then carried out in dried and pre-heated molds at an optimal impregnation temperature.

These temperatures are close to those of a transformer in service, enabling mechanical stresses to be eliminated which could lead to the coating cracking.

HV coil support wedges

The high voltage winding is centered on the magnetic core and held in place vertically by an efficient wedging system. Thanks to the unique design of these wedges they can be assembled in a variety of ways to suit different levels of HV insulation.

The wedges are designed according to customers' needs to cope with different environmental and mechanical conditions (seismic withstand, vibration etc.).



HV coil support wedges

Notes

Product description

Product description

General characteristics	28
Example of characteristics for Trihal	31
Up to 3150 kVA, 12 kV, losses - $A_0 A_k$	31
Up to 3150 kVA, 17.5 kV to 24 kV, losses - $A_0 A_k$	32
Up to 3150 kVA, 36 kV, losses - $A_0 A_k$	33
for other models see page ->	60

General characteristics

PM106810

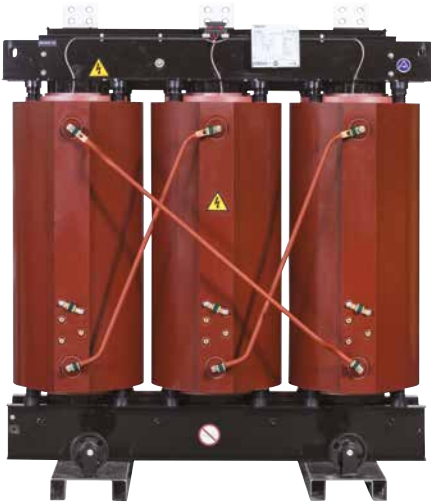

Product at a glance

Cast resin, 50 Hz, three-phased distribution transformers with the following characteristics:

- Indoor use / Outdoor use with properly designed enclosure
- Thermal class F - Temperature rise 100 K
- Ambient $\leq 40^{\circ}\text{C}$, altitude ≤ 1000 m
- MV windings encapsulated in cast resin
- Pre-impregnated LV windings
- Natural air cooling system (AN type)
- Core and frame covered with protective coating
- Anti-corrosion surface treatment : corrosivity category class C2, "Medium" durability (according to ISO 12944-2)

Eco-design

EU is implementing its «20-20-20» program by 2020 :

- Reduction of 20 % of greenhouse gases emission
- Reduction of 20% of energy consumption
- Reach 20% from renewable energy in total production

Power Transformer losses represents about 2.5% of total EU energy consumption
By 2020, savings of approximately 16TW h/year are achievable with new regulation.

Ecodesign aims for 2 major objectives on Transformers:

- Reduce electrical losses (1 step in 2015/ 2nd step in 2021)
- Clarify and make more visible indication of performance

More info: A_0 10% - A_k (tier 2)

To help you to choose the best efficient transformer, please find in the white paper a table tier 1 V.S tier 2.

*For more info clic **here** to read the white paper*

Offer available upon request.

Compliance:

These transformers comply with standards:

- IEC 60076-11
- EN 50588-1

Schneider Electric guarantees that its transformers are silicone free and certified:

- C3* Climatic class
- E3 Environment class according to IEC 60076-16
- F1 Fire behaviour class
- Almost partial discharge free - Acceptance level:
 - ≤ 10 pC Routine Test
 - ≤ 5 pC Special Test according to IEC 60076 standard

* C2 Thermal shock test carried out at -50°C

Standard fittings

Trihal without enclosure (IP00):

- HV voltage variation by off circuit tapping links
- 4 bi-directional flat rollers
- 4 lifting holes
- 4 haulage holes on the underbase
- 2 earthing points
- 1 rating plate (on HV side)

Trihal with IP31 metal enclosure:

- Trihal IP00 as above
- IP31 metal enclosure (except the bottom: IP21):
 - 2 lifting lugs for transformer and enclosure assembly
 - 1 earthing point on enclosure
 - access to HV tapping by removing a bolted panel
 - enclosure final colour RAL9002

Optional fittings

- Temperature sensors located in the LV windings
- Electronic temperature monitor (Z converter or T digital thermometer)
- Easergy TH110: wireless smart sensors ensuring the continuous thermal monitoring of all the critical connections
- Easergy TL110: ambient monitoring
- + 40 % AF cooling system with fans
- Custom enclosures with special paint colors, IP level (up to IP44) or anti-corrosion treatment
- Earthing balls, Surge arrestors, Antivibrations pads
- 3 HV plug-in bushings (IP00 or IP31)
- Locking device for plug-in bushings (lock in option)
- 3 mobile connectors for plug-in bushings straight or elbow (cable characteristics must be specified)

The above descriptions / options concern usual cases and are not restrictive. For any other requests (special site conditions, temperature rise, housing design, etc.), please consult us.

Connections - Trihal transformers without enclosure housing (IP 00)

The winding resin coating and the plug-in connectors don't ensure any protection against touch when the transformer is energized. The contractor must ensure that cables and busbars are adequately supported to prevent mechanical stresses from being imposed on the transformer terminals, busbars or bushings.

Minimum clearances required

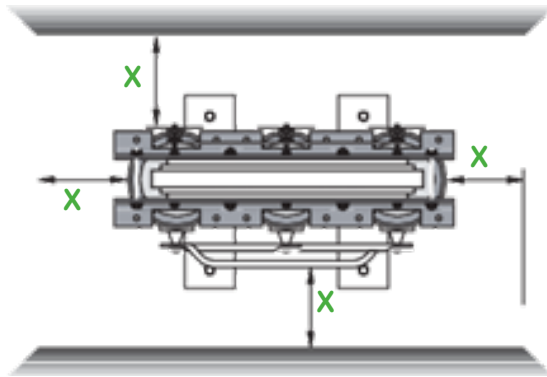

Insulation (kV)	Dimension X (mm)	
	Fukl wall	Grid wall
7.5	90	300
12	120	300
17.5 - 24	220	300

HV and LV connection

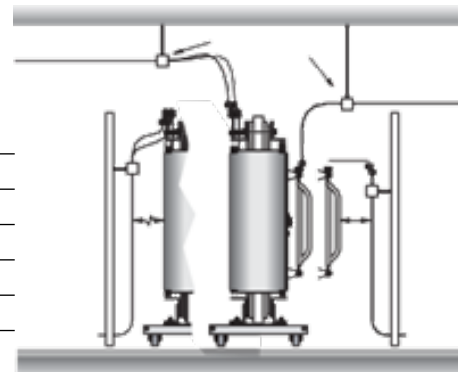

According to HD 637-1.

Don't take into account the access to tapping on the UV side.

Connections - Trihal transformers with IP 31 metal enclosure

Minimum clearances required

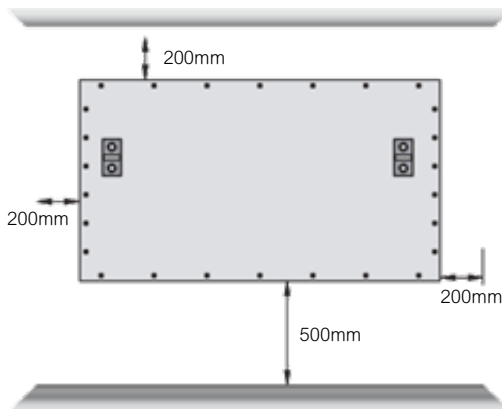

HV and LV connection

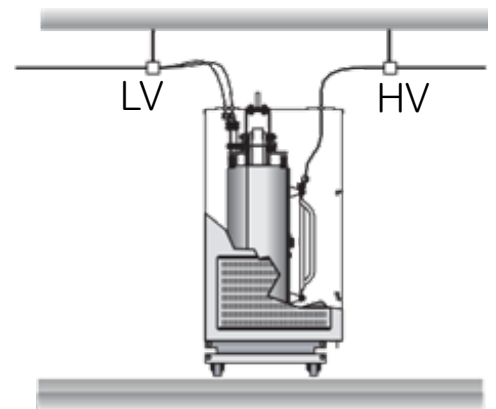

Terminations

LV Terminations

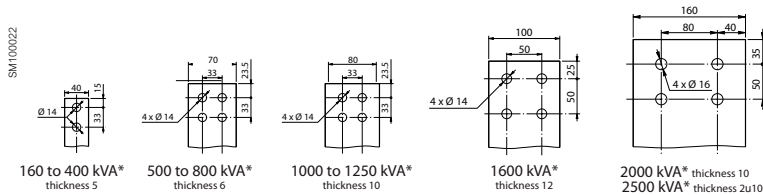

*Valid for aluminium terminations.

HV Terminations - EN 50180

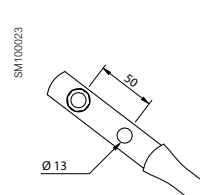

Routine fittings such as bar and cable supports, flexible connectors, etc. will be supplied by the contractor, who will ensure that the transformer terminals are not subject to mechanical stresses.

Trihal - Cast Resin Transformer
Up to 3150 kVA - 12 kV - C3 E3 F1 5pC

Main electrical characteristics

Power kVA	100	160	250	315	400	500	630	800	1000	1250	1600	2000	2500	3150
Primary voltage	15 or 20kV													
Secondary voltage	400 to 433V between phases, 231 to 250V phase to neutral (at no load)													
HV insulation level	17.5kV for 15kV - 24kV for 20kV													
HV tapping range	± 2.5 % and/or ± 5 %													
Vector group	Dyn 11, Dyn 5, Dyn 1 (other vector groups upon request)													
No-load losses (w)	280	400	520	620	750	900	1100	1300	1550	1800	2200	2600	3100	3800
Load losses at 75°C (w)	1800	2600	3400	3876	4500	5630	7100	8000	9000	11000	13000	16000	19000	22000
Load losses at 120°C (w)														
Impedance voltage (%)	6	6	6	6	6	6	6	6	6	6	6	6	6	6
Acoustic Level dB(A):														
- power L _{WA}	51	54	57	59	60	58	62	64	65	67	68	70	71	73
- pressure L _{PA} (1m)	39	42	45	46	47	45	49	51	51	53	54	56	56	58

Dimensions* and weights

Without enclosure (IP00)

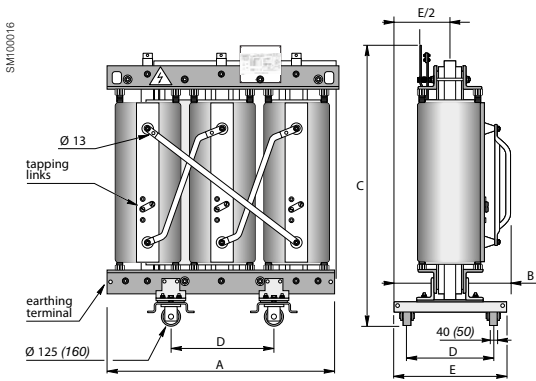

With IP31 metal enclosure

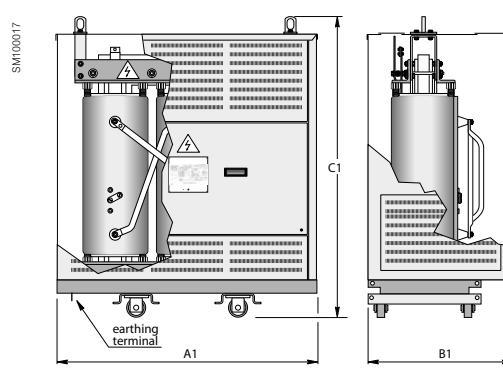

Rated power (kVA)		100	160	250	315	400	500	630	800	1000	1250	1600	2000	2500	3150
Without enclosure IP00															
Dimensions (mm)	-A	1030	1110	1250	1270	1320	1420	1430	1530	1580	1590	1790	1880	1940	2090
	-B	520	520	520	670	670	670	670	670	820	820	820	1070	1070	1070
	-C	1260	1280	1390	1470	1620	1550	1550	1720	1860	1960	1940	2130	2170	2430
	-D	645	645	645	795	795	795	795	795	945	945	945	1230	1230	1230
	-E	650	650	670	800	800	800	800	800	950	950	950	1230	1230	1270
Total weight (kg)		660	820	1100	1300	1560	1800	1820	2440	2800	2940	3520	4300	5080	6400
With IP31 metal enclosure															
Dimensions (mm)	-A1	1650	1650	1510	1800	1900	1800	1800	1900	2150	2150	2020	2100	2240	2390
	-B1	950	950	770	1020	1100	1020	1020	1100	1170	1170	950	1230	1230	1270
	-C1	1750	1750	1690	2050	2300	2050	2050	2300	2480	2480	2240	2430	2570	2830
Weight enclosure (kg)		180	180	200	210	240	210	210	240	320	320	400	400	400	400
Total weight (kg)		840	1000	1300	1510	1800	2010	2030	2680	3120	3260	3920	4700	5480	6800

* see page 18 all available Trihal technical range

Trihal - Cast Resin Transformer Up to 3150 kVA - 17.5 to 24 kV - C3 E3 F1 5pC

Main electrical characteristics

Power kVA	100	160	250	315	400	500	630	800	1000	1250	1600	2000	2500	3150
Primary voltage	15 or 20kV													
Secondary voltage	400 to 433V between phases, 231 to 250V phase to neutral (at no load)													
HV insulation level	17.5kV for 15kV - 24kV for 20kV													
HV tapping range	± 2.5 % and/or ± 5 %													
Vector group	Dyn 11, Dyn 5, Dyn 1 (other vector groups upon request)													
No-load losses (w)	280	400	520	630	750	900	1100	1300	1550	1800	2200	2600	3100	3800
Load losses at 75°C (w)	1620	2340	3060	3510	4050	5130	6390	7200	8100	9900	11700	14400	17100	19800
Load losses at 120°C (w)	1800	2600	3400	3900	4500	5700	7100	8000	9000	11000	13000	16000	19000	22000
Impedance voltage (%)	6	6	6	6	6	6	6	6	6	6	6	6	6	6
Acoustic Level dB(A):														
- power L _{WA}	51	54	57	59	60	61	62	64	65	67	68	70	71	74
- pressure L _{PA} (1m)	39	42	45	46	47	48	49	50	51	53	53	55	56	58

Dimensions* and weights

Without enclosure (IP00)

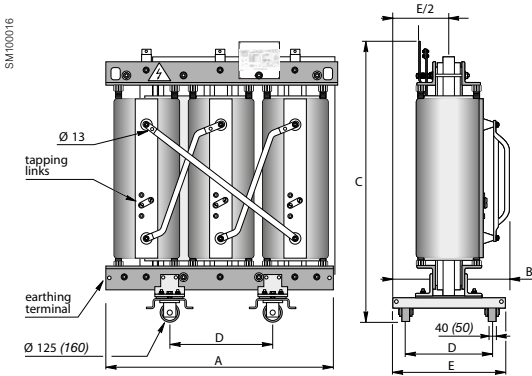

With IP31 metal enclosure

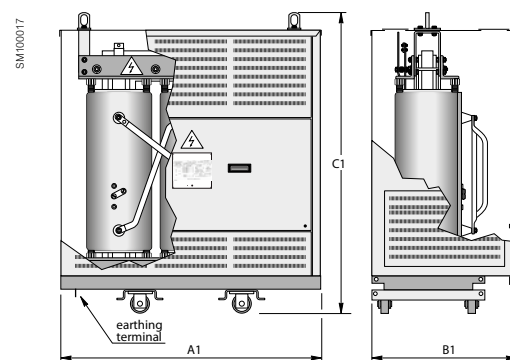

Rated power (kVA)		100	160	250	315	400	500	630	800	1000	1250	1600	2000	2500	3150
Without enclosure IP00															
Dimensions (mm)	-A	1290	1260	1330	1350	1410	1430	1500	1660	1660	1710	1790	1880	2070	2280
	-B	720	720	720	800	800	800	800	800	950	950	950	1200	1200	1200
	-C	1370	1370	1430	1580	1600	1620	1640	1810	1950	2100	2340	2420	2480	2660
	-D	520	520	520	670	670	670	670	670	820	820	820	1070	1070	1070
	-E	715	715	715	795	795	795	795	795	945	945	945	1195	1195	1195
Total weight (kg)		940	930	1200	1360	1580	1660	1920	2550	2790	3200	4000	4950	6160	8370
With IP31 metal enclosure															
Dimensions (mm)	-A1	1650	1650	1650	1700	1700	1800	1800	2000	2000	2150	2330	2330	2470	2680
	-B1	950	950	950	1020	1020	1020	1020	1170	1170	1170	1240	1270	1240	1310
	-C1	1750	1750	1750	1900	1900	2050	2050	2400	2400	2480	2650	2650	2880	3060
Weight enclosure (kg)		180	180	180	190	190	210	210	245	245	320	370	370	350	360
Total weight (kg)		1120	1110	1380	1550	1770	1870	2130	2795	3035	3520	4370	5320	6510	8730

* see page 18 all available Trihal technical range



Trihal - Cast Resin Transformer Up to 3150 kVA - 36 kV - C3 E3 F1 5pC

Main electrical characteristics

Power kVA	160	250	400	630	800	1000	1250	1600	2000	2500	3150
Primary voltage	28.5 to 34.5 kV										
Secondary voltage	400V between phases, 231V phase to neutral (at no load)										
HV insulation level	36kV										
HV tapping range	± 2.5 % and/or ± 5 %										
Vector group	Dyn 11, Dyn 5, Dyn 1 (other vector groups upon request)										
No-load losses (w)	850	1000	1200	1400	1650	1900	2200	2550	3000	3500	4100
Load losses at 75°C (w)	2180	3050	4350	6090	7310	8700	10440	12180	14790	17400	21740
Load losses at 120°C (w)	2500	3500	5000	7000	8400	10000	12000	14000	17000	20000	25000
Impedance voltage (%)	6	6	6	6	6	6	6	6	6	6	6
Acoustic Level dB(A):											
- power L _{WA}	57	59	61	63	64	65	67	68	72	73	76
- pressure L _{PA} (1m)	44	46	48	49	50	50	52	53	56	57	60

Dimensions* and weights

Without enclosure (IP00)

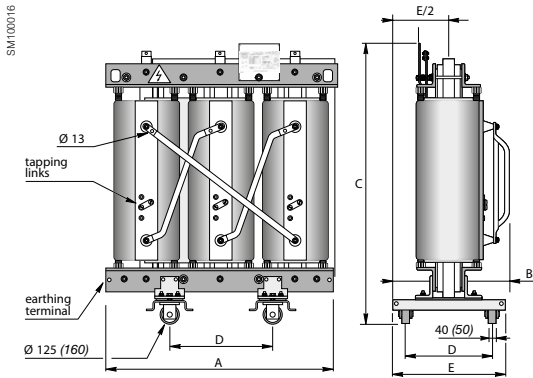

With IP31 metal enclosure

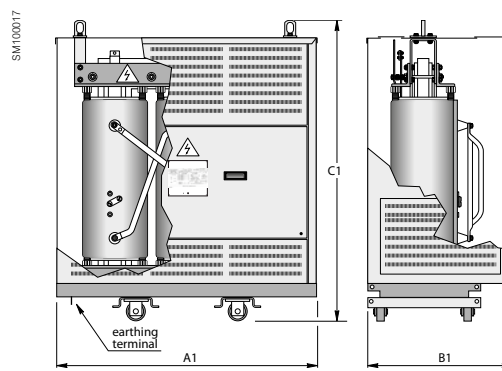

Rated power (kVA)		160	250	400	630	800	1000	1250	1600	2000	2500	3150
Without enclosure IP00												
Dimensions (mm)	-A	1510	1480	1520	1620	1750	1800	1860	1940	2250	2360	2690
	-B	800	800	880	900	920	1000	1010	1020	1200	1220	1280
	-C	1750	1770	1810	1990	2140	2220	2440	2480	2450	2650	2670
	-D	520	520	670	670	670	820	820	820	1070	1070	1070
	-E	715	715	795	795	795	945	945	945	1195	1195	1195
Total weight (kg)		1460	1540	1860	2460	3040	3520	4200	5100	6930	7840	11280
With IP31 metal enclosure												
Dimensions (mm)	-A1	2110	2080	2120	2220	2350	2400	2460	2540	2850	2960	3290
	-B1	1230	1220	1230	1270	1310	1320	1340	1370	1480	1510	1620
	-C1	2050	2070	2110	2290	2440	2520	2740	2780	2850	3050	3070
Weight enclosure (kg)		200	200	200	300	300	300	300	400	400	400	400
Total weight (kg)		1660	1740	2060	2760	3340	3820	4500	5500	7330	8240	11680

* see page 18 all available Trihal technical range

Options and accessories

Options and accessories

Options	36
Trihal Cast/Cast	36
Trihal LV/LV up to 400 kVA - 1.1 kV	36

Thermal Protection	37
T thermal protection using PT100 sensors	37
Z thermal protection using PTC sensors	38

Forced Ventilation	39
---------------------------	-----------

Connections	40
Low voltage connections	40
High voltage connections	40
High voltage surge arresters	41
Vibration damping	41

Protective Enclosure	42
IP protection indices	42
IK protection indices	42

Enclosure QI (Quick Installation)	43
Quick Installation Solution	43
IK protection indices	43

Trihal Cast/Cast benefits:

- Totally insensitive to harsh environments (pollution or condensation)

Trihal Cast / Cast

Trihal Cast / Cast Cast Resin transformers provide high reliability and long durability with both MV and LV windings casted under vacuum. It is a perfect solution for harsh environmental conditions such as high pollution or humidity. It also provides enhanced mechanical and thermal features.

Application fields:

- O&G, MMM,
- Utilities, Power plants, Water, Nuclear

Trihal LV/LV benefits:

- Guaranteed against fire hazards (self-extinguishing)
- Totally insensitive to harsh environments (pollution or condensation)
- Easy and quick to install with a minimum maintenance

Trihal LV/LV up to 400 kVA - 1.1 kV

Trihal LV/LV Cast Resin transformers provide reliability and longevity in harsh environmental conditions such as high pollution or humidity. It adapts to significant temperature and charge variation constraints.

Description:

Trihal LV/LV is suitable for:

- Earthing transformer
- Change of earthing system
- Isolate network disturbances
- Change of network voltage
- Galvanic isolation
- Energy conversion
- Dimmer monitoring
- High power transformer pre-magnetization

Application fields:

- Buildings
- Industry
- Oil & Gas
- Marine
- Secure Networks



Trihal LV/LV

Thermal protection

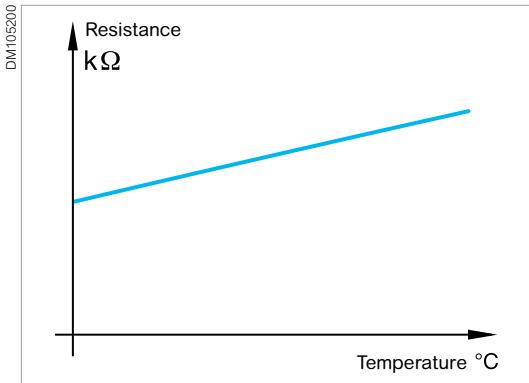

Typical graph of a PT100 sensor

The Trihal cast resin transformer can be protected by monitoring the winding temperature.

This monitoring is done by:

- PT100 sensors + associated relay for alarm and trip and real-time temperature monitoring
- PTC sensors + associated relay for alarm and trip

T thermal protection using PT100 sensors

This thermal protection device gives a digital display of the winding temperatures and includes:

- **PT100 sensors**
 - The main feature of a PT100 sensor is that it gives the real-time temperature on a scale of 0°C to 200°C, see graph opposite (accuracy 0.5% of the measurement scale 1 degree).
 - Temperature control and display functions are performed via a digital thermometer. The 3 sensors, each comprising 1 white wire and 2 red wires, are installed in the live part of the Trihal transformer with 1 located on each phase
 - They are placed in a tube, allowing them to be replaced if necessary.
- **1 terminal block for connecting the PT100 sensors to the T digital thermometer**
 - The terminal block is equipped with a plug-in connector. PT100 sensors are supplied connected to the terminal block fixed to the top of the transformer.
- **1 T digital thermometer characterized by 3 independent circuits.**
 - 2 of the circuits monitor the temperature captured by the PT100 sensors, one for alarm 1, the other for alarm 2. When the temperature reaches 140°C (or 150°C) the alarm 1 information (or alarm 2/tripping) is processed by 2 independent output relays equipped with changeover contacts. The position of these relays is indicated by 2 diodes (LEDs).
 - The third circuit monitors sensor or electrical supply failure. The corresponding relay (FAULT), which is independent and equipped with changeover contacts, is instantly switched as soon as the device is supplied with power. Its position is also indicated by a diode (LED).

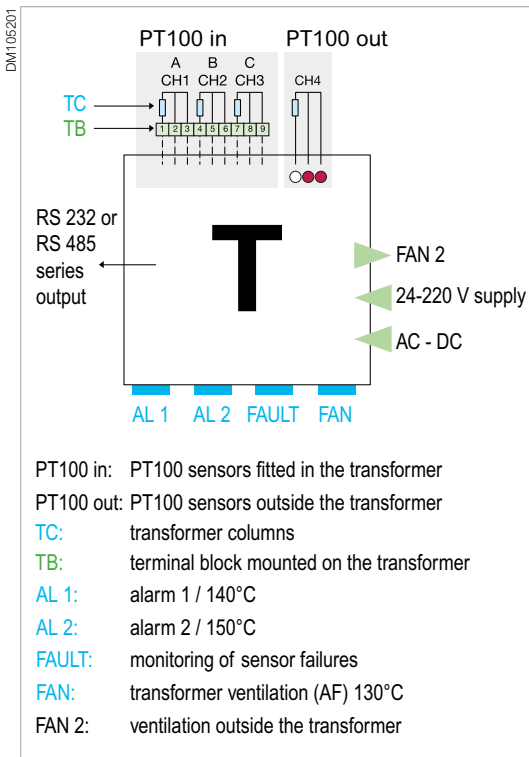

Schematic diagram for the T digital thermometer



Please note: since the transformer is thermal Class F, the user has responsibility for setting the T digital thermometer with a maximum temperature of 140°C for alarm 1 and 150°C for alarm 2 (tripping). Failure to comply with these maximum temperatures absolves Schneider Electric of any liability for damage that could possibly be incurred by the transformer.

The purpose of a FAN output is to control starting of tangential fans in the event of forced ventilation of the transformer (AF): this option is shown on page 21.

An additional input (CH4) can be connected to a sensor outside the transformer (not supplied), intended to measure the ambient temperature in the HV/LV substation.

A digital output (RS 232 or 485) or a 4-20 mA analog output is available for connection to a PLC or computer.

A FAN 2 output is available as an option to control starting of an additional fan.

The T digital thermometer is delivered with an installation manual.

Thermal protection

Z thermal protection using PTC sensors

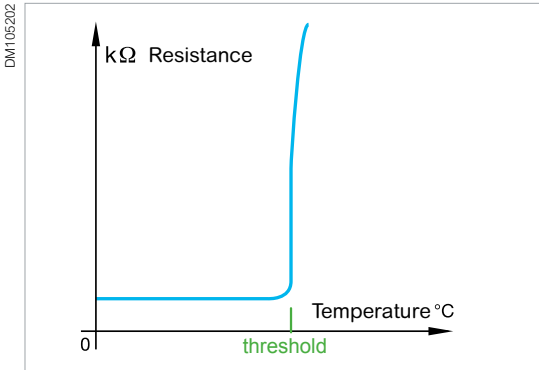

Typical graph of a PTC sensor

The standard version for naturally cooled (AN) transformers comprises:

- **2 PTC sensor sets, positive temperature coefficient thermistors mounted in series:** the first set for alarm 1, the second set for alarm 2.

The PTC sensor resistance increases very steeply at a rated and factory-set threshold temperature which is not adjustable (see graph opposite). This abrupt increase is detected by a Z electronic converter.

These sensors are installed in the live part of the Trihal transformer with one alarm 1 sensor and one alarm 2 sensor on each phase. They are placed in a tube, allowing them to be replaced as necessary.

- **1 terminal block for connecting the PTC sensors to the Z electronic converter.** The terminal is equipped with a plug-in connector. The PTC sensors are supplied connected to the terminal, attached to the top of the transformer.

- **1 Z electronic converter characterized by 3 independent measurement circuits.** 2 of these circuits respectively control the variation in resistance in the 2 PTC sensor sets. When the temperature increases too much, the alarm 1 (or alarm 2) information is processed respectively by the 2 independent output relays equipped with a changeover contact; the status of these 2 relays is indicated via 2 LED diodes.

The third measurement circuit is shunted by a resistor R outside the terminal block; it can control a third set of PTC sensors as long as this resistor is removed. In this case ("forced air" option available on request), the FAN information is processed by a third independent output relay, equipped with a closing contact and is intended to control fans; the position of this relay is shown by an LED diode marked FAN.

In the event of one of these 3 sensor circuits failing (power failure or short-circuit), an LED diode marked SENSOR lights up and indication of the incriminated circuit flashes. An LED diode marked ON signals the presence of voltage to the terminal block.

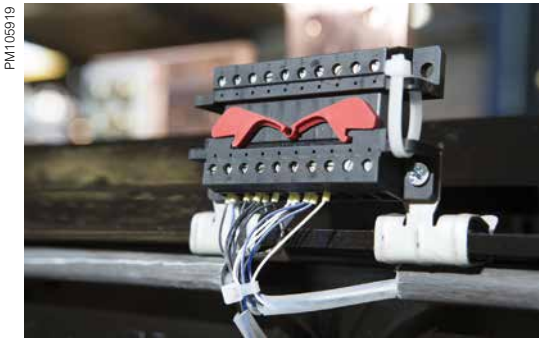

Terminal block for connecting sensors to the electronic converter

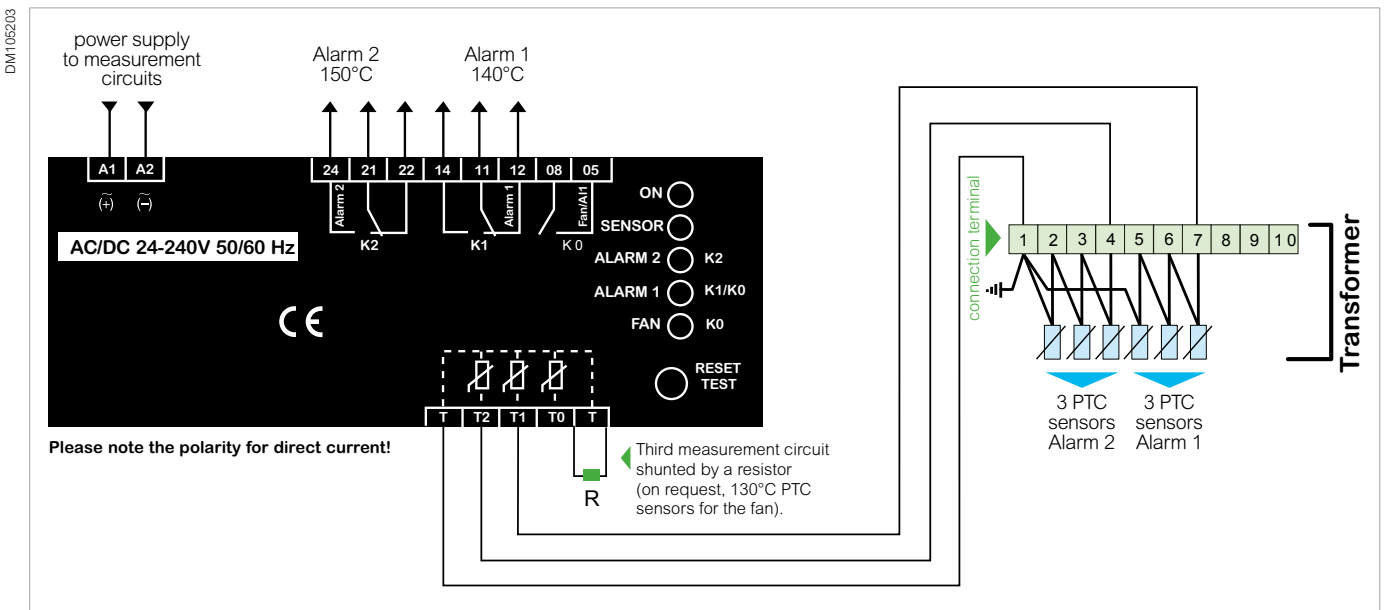

Z thermal protection connection diagram (normal use), equipment de-energized

Forced Ventilation

PMT105820



Force-ventilated transformer in IP31 enclosure

In the event of a temporary overload, to avoid overheating of the windings, it is possible to install forced ventilation.

It is then possible to increase the transformer power up to 40%.

In this case, the following points must be considered:

- the cross-sections of the cables and Prefabricated Busbar Trunking (PBT)
- the rating of the transformer's protective circuit breaker
- the size of the inlet and outlet air vents in the transformer room
- the life span of fans in service

This option includes the supply of:

- 2 sets of tangential fans, pre-cabled and connected to a single power connector per set
- 1 temperature measurement device, either Z or T type

For Z type, a third set of PTC sensors is added to the standard thermal protection instead of the R resistor which originally shunted the third Z converter measurement circuit (see diagram shown in the Z thermal protection option).

For T type, the digital converter comprises an output (FAN) intended to start the tangential fans (see diagram shown in the T thermal protection option).

This option includes, depending on transformer type:

- a wiring box, mounted outside the protective enclosure, to which sensors and power supplies for the fan sets are connected on a terminal block
- a control cabinet, supplied separately (transformer IP00) or mounted on the protective enclosure, including:
 - motor protection fuses
 - starting contactors
 - thermal protection device

This unit is connected to the temperature sensors and fan sets if the transformer is supplied with an enclosure.

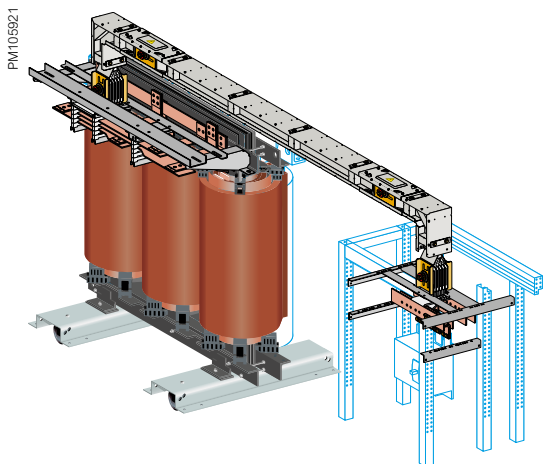

Picture 1: Tangential fans on IP00

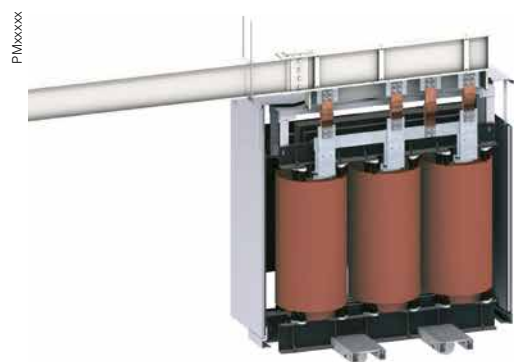

Picture 2



HV connections

Low voltage connection

Cable ducting interface

Connection using Prefabricated Busbar Trunking (PBT) provides advantages in terms of safety and also saves time during connection.

This solution ensures maximum safety for people and property due to its outstanding fire behaviour, in line with that of Trihal. It also ensures the absence of halogenated products, which is not the case for cabling.

The option includes the connection interface, together with the junction block, with the whole assembly delivered already mounted on the LV cable connectors.

If the protective enclosure is provided, a removable aluminum plate is screwed to the roof, vertical relative to the junction block.

It will be adapted on site in order to fit the sealing system connecting the PBT. If the transformer enclosure is supplied, the sealing system is supplied with the PBT.

Additional cable connectors

Additional cable connections can be provided according to the number of the cables.

Trihal transformers can be delivered with prepared connection to Canalis KT (picture 1) or can be connected thanks to universal connection (picture 2).

[Clic here](#) for more info on Canalis solutions

[Clic here](#) to see the installation video

High voltage connection

Plug-in bushings

Plug-in bushings can be provided for the HV plug-in connectors. They can be fitted:

- on a horizontal panel, on the top of the HV side for transformers without a protective enclosure (IP00)
- on the enclosure roof, HV side, for transformers with a protective enclosure

A locking system for the connectors can also be supplied and installed in plug-in bushings.

Connection

PM105923



High voltage surge arresters on the lower part

High voltage surge arresters

If the installation is likely to be subjected to overvoltage of any kind (atmospheric or switching), the transformer must be protected by phase-to-earth surge arresters, installed directly on the transformer's HV connection terminals (either at the top or the bottom).

It is essential to install these surge arresters:

- where the lightning impact level N_k is greater than 25. The risk of direct or induced atmospheric overvoltage is directly proportional to N_k
- during occasional switching (less than 10 operations a year) of a transformer with a weak load, or during a magnetization phase.

It is also highly recommended to install them:

where the substation is supplied by a network including overhead parts, then a cable longer than 20 m (case of an overhead-underground network)

Surge arresters can be installed in an IP 31 enclosure, or even on existing equipment, provided that insulation distances are adhered to.

PM105481



PM105479



Anti-damping accessories

Vibration damping

Roller anti-vibration pads

This accessory, placed under the rollers, avoids vibrations being transmitted from the transformer to its environment.

Damper unit

This device is installed instead of the roller and enables transmission of vibrations to the transformer environment to be attenuated.

Protective Enclosure

PM105924



Protective enclosure IP31, IK7

Bracket for HV cables entering the bottom of the enclosure

Where required, an HV cable bracket is available as an option to guide and support cables entering the enclosure from the bottom, via a removable, screw-on aluminum plate. And much more accessories like:

- Temperature monitor
- Antivibration pads
- Electrostatic screen
- Current transformers on primary and secondary windings
- Surge arrestors (for high and low voltage)
- On load tap changers (OLTC)
- Different IP/NEMA enclosures with cable or bus-duct connection
- Flexible terminals
- Connection box
- Bidirectional wheels
- Plug in bushings
- Cooling fans
- Earthing bullets
- Lifting and pulling lugs
- Special packings
- Cable boxes

The IP and IK protective indices refer to the following criteria:

IP protection indices

IP	First Number (against foreign bodies)	Second Number (protection against water)
0	No protection	No protection
1	Bodies $\varnothing \geq 50 \text{ mm}$	Vertical dripping water
2	Bodies $\varnothing \geq 12.5 \text{ mm}$	Dripping water angle 15°
3	Bodies $\varnothing \geq 2.5 \text{ mm}$	Dripping water angle 60°
4	Bodies $\varnothing \geq 1 \text{ mm}$	Spray from all direction
5	Deposit of dust	Jets from all direction
6	Entry of dust	Flood
7	-	Immersion (limited duration)
8	-	Immersion (unlimited duration)

Common design – indoor use

- IP21, IP31, IP23

Custom enclosure – outdoor use

- IP35
- IP44

Special product – SPT

- Up to IP54 – dust proof

Certificate

- Manufacturer approved
- Independent laboratory

IK protection indices

Definition	Protection against mechanical impact
Scale ⁽¹⁾	0 to 10
IK7	protection against mechanical impact $\leq 2 \text{ joules}$
IK10	protection against mechanical impact $\leq 20 \text{ joules}$

(1) 0 = no protection

With IP35 and IP44, transformers can be installed outdoors.

Enclosure Quick Installation (QI)

Enclosure QI



Easy to buy
4 different models



Easy to install

Customer testimony:

"...Schneider Electric Enclosure QI fully answers to our needs, with only 85kg against 350kg from competition, it is much lighter than competition one. Thanks to Schneider Electric we saved 1000€ as we spent only 50mn to assemble it, when on last order from competition we spent 1,5 days...**"**

Quick Installation Solution

The enclosure QI (Quick Installation) allows more flexibility and adaptability for quick installation on site. This safe, reliable, very light, easy to buy and install innovative assembling enclosure permits fast assembly and disassembly using just one tool, 1 screw-gun and 2 people. Our solution is 4 times lighter than actual competition with only 80 kg to 170 kg. Within 45 mn, the enclosure can be assembled/disassembled around the transformer which will facilitate door crossing (building, industry, windfarm,...). The benefit of our product digitization, for instance, using the QR code in front of the transformer, gives access to a detailed training installation video.

Upon request, you can also include HV Plug-In bushings on top of enclosure.

For lifting device with or any other enclosure option, please refer to standard enclosure chapter

IK protection indices

Definition	Protection against mechanical impact
Scale ⁽¹⁾	0 to 10
IK7	protection against mechanical impact <=2 joules

(1) 0 = no protection



Please note: All Enclosure QI dimensions should be provided by our commercial team. Enclosure's dimensions in the «Product description» section of this document does not concern kit form enclosures (Enclosure QI).

Tests and specifications

Tests and specifications

Tests	46
C3* Climatic Test	46
E3 Environmental Test	46
F1 fire withstand	47
Partial discharge $\leq 5\text{pC}$	47
Electrical tests	48
<hr/>	
EcoDesign Regulation EU 548-2014	49
<hr/>	
Order form	51
<hr/>	

Tests

Safety and reliability

The new worldwide quality reference:
C3*E3F1 with partial discharge $\leq 5\text{pC!}$

C3* climatic tests

done on a Trihal 1000 kVA, 20kV, 50Hz

Trihal takes climatic testing to a new level.

The highest certification described by IEC 60076-11, C2 imposes thermal shock testing to a maximum of -25°C .

Trihal passes the same tests at -50°C , ensuring optimal performance even in extreme climates.

Lowest ambient temperatures:

- Operation -50°C
- Storage -50°C

Benefits:

- Resistance to thermal shock
- Optimum performance under severe ambient conditions
- Superior behaviour on load changes
- Extended service life

E3 environmental test

done on a Trihal 1000 kVA, 20kV, 50Hz

Test conducted in two parts according to standards IEC 60076-11 and IEC 60076-16:

Condensation test

- 6 hours with 95% humidity (by indirect spraying of water with conductivity of between 3.6 and 4 S/m)
- Induced voltage test

Humidity penetration test

- 6 days at 50°C with 90% (+/-5%) humidity
- Dielectric tests
- Visual inspection

PM1102677



* C2 thermal shock test carried out at -50°C

PM1102678



E3 environmental test

Tests

Safety and reliability

PM1102679



F1 fire withstand tests

F1 fire withstand

done on a Trihal 1000 kVA, 20kV, 50Hz

The fire behaviour test is conducted in a specific test chamber according to the procedure described in standard IEC60076-11:

- 1 tank of ethyl alcohol (sufficient quantity for 20 mins combustion) burns under the tested coil
- 1 panel heater in front of the tested coil
- 1 reflector, concentric to the coil, is fitted opposite the panel heater

PM1102680



The 2 fire-proof effects of the resin used in Trihal made it possible to observe:

- Immediate self-extinguishing of Trihal as soon as the flames from the alcohol tank die down and the panel heater is switched off
- Absence of halogen products, toxic emissions and opaque smoke

Partial discharge $\leq 5\text{pC}$

done on a Trihal 1000 kVA, 20kV, 50Hz

A partial discharge is the dissipation of energy caused by the build-up of localized electrical field intensity.

These phenomena, defined by standard IEC 60270, cause the insulation to deteriorate progressively and can lead to electrical breakdown.

The integrity of the transformer insulation is confirmed during Partial Discharge Analysis and used as a tool to judge the state of the device and the quality of its manufacture.

As proof of our progress in terms of quality, the acceptance criteria applicable to all new Trihal are now $\leq 10\text{ pC}$ during routine tests or $\leq 5\text{ pC}$ in the case of special tests ordered by the customer according to standard IEC 60076-11.

PM1102681



PM1102682



Partial discharge test reports

Tests

Safety and reliability

PMT105925



Routine test lab

Electrical tests

These tests verify the contractual electrical characteristics. They include:

Routine tests

These tests are systematically carried out on all Trihal transformers at the end of manufacturing and are subject to an official test report.

They comprise:

- **Measurement of characteristics:**
 - winding resistance
 - transformation ratio and vector group
 - impedance voltage
 - load losses
 - no-load losses and no-load current
- **Dielectric tests:**
 - applied voltage tests 10 kV as standard in LV
 - Induced voltage tests up to 2.5 U_n to grant our high level transformer quality
 - measurement of partial discharge

Type tests and special tests

On request as per relevant standards.

These are carried out on request and at the customer's expense.

- Full wave lightning impulse test internal.
Chopped wave upon request performed on external laboratories
- Short-circuit tests (external laboratory)
- Noise level measurements
- Others on request (according to IEC 60076-11)

EcoDesign Regulation EU 548-2014

PMT105926



EcoDesign is a European Union regulation which came into force on 11th June 2014 in the 28 countries of the European Union.

This new legislation imposes, within the EU, the maximum level of losses for transformers placed on the market or commissioned from 1st July 2015 and purchased after 11th June 2014.

After the date of entry into force, manufacturers should not enter into new framework contracts for transformers with energy efficiency specifications below the minimum requirements outlined in the regulation.

Framework contracts signed before 11th June 2014 can continue until the end date, even with deliveries after 1st July 2015.

- EcoDesign has two major objectives for the transformer product:
- Reducing electrical losses (1st phase in 2015/2nd phase in 2021)
- Clarifying and improving the visibility of indication of performance
- Harmonization of maximum loss levels in the European Union
- Efficiency request on medium-power transformers for the first time.

The following equipment is affected:

- All transformers exceeding 1 kVA and with voltage higher than 1 kV
- Oil Distribution and Dry-type transformers (≤ 3150 kVA) with high voltage winding above 1.1 kV and up to 36 kV
- Medium power and Large power transformers > 3150 kVA and higher than 36 kV (limited to 10 MVA 36 kV for Dry-type Transformers).

Special transformers are not affected by this regulation (please refer to restriction list for details).

Authorized loss levels for Oil Distribution and Dry-type Transformers (≤ 3150 kVA):

Maximum loss levels	Rated power	Tier 1: from 01.07.2015	Tier 2: from 01.07.2021
Dry-Type transformers	≤ 630 kVA	AoBk	Ao-10% Ak
	> 630 kVA	AoAk	

- Loss levels to be applied (reference of MV ≤ 24 kV and LV ≤ 1.1 kV)
- ODT and CRT not covered by reference transformers:
(additional losses allowed compared to standard loss ranges)

Other requirements	Impact on no-load losses compared to standard losses table	Impact on load losses compared to standard losses table
MV insulation level \leq 24 kV LV insulation level $>$ 1.1 kV	10%	10%
MV insulation level = 36 kV LV insulation level \leq 1.1 kV	15%	10%
MV insulation level = 36 kV LV insulation level $>$ 1.1 kV	20%	15%
Dual voltage on MV winding and 85% power limitation on higher MV voltage	No impact	No impact
Dual voltage on MV winding and 85% power limitation on higher LV voltage	No impact	No impact
Dual voltage on one winding (MV or LV) and full power on all voltages considered	15%	10%
Dual voltage on both windings (MV and LV)	20%	20%
Transformers with tapplings for operation while energized (such as Voltage Regulation Distribution Transformers)	20% (reduced to +10% in 01-07-2021)	5%

E.g.: ODT 630 kVA, 33 kV - 410 V max. losses to be considered: A0+15% - Ck +10%

Order form

For each requested transformer, please provide the following data:

Rated power	kVA
Cooling	
Quantity	
Rated frequency	Hz
Rated primary voltage	kV
Highest primary voltage for equipment (Um)	kV
Primary applied voltage or line terminal AC withstand	kV
Rated lightning impulse withstand voltage	kV
Off-circuit tapping	%
Secondary voltage at no load	
- between phases	V
- phase to neutral	V
Highest Secondary Voltage for equipment (Um)	kV
Secondary Applied voltage or line terminal AC Withstand	kV
Vector group	Dyn
No load losses	W
Load losses at 120° C	W
Rated impedance voltage at 120° C	%
Acoustic power L _w (A)	dB(A)
Maximum ambient temperature	40 °C
Maximum altitude	1000 m
Average ambient temperature out of accessories (hottest month of the year)	30 °C
Average annual temperature	20 °C
MV winding temperature class	F
LV winding temperature class	F
Temperature of insulation system	155 °C
Climatic classification	C3*
Environmental classification	E3
Fire behaviour classification	F1
Minimum temperature (transportation, storage and operation) :	- 50 °C
Enclosure	Yes / Non ⁽¹⁾
Index of protection	IP ..
Length	mm
Width	mm
Height	mm
Total weight	kg
Thermal protection relay, electronic converter type :	Yes / No ⁽¹⁾

⁽¹⁾ Delete as appropriate

Digital tools

Digital Tools

Accelerate your business Commercial and Industrial Buildings	54
Connected for efficiency and reliability Trihal EcoStruxure™ ready	55
Helpfull tools	56
Total Cost of Ownership	57
BIM models	58

Accelerate your business

Commercial and Industrial Buildings



Schneider Electric offers its Partners, a Medium Voltage Business accelerator for the building market. Specifiers, Contractors, Panel builders and Distributors access now to the tools, services and fast-paced delivery they need to quicker and safer completion of MV projects and win more business!

Easy selection

Choose from a range of referenced products and get off-the-shelf product configurations.

Quick configuration and quotes

Select products online and fast-track your customers' projects by submitting accurate quotes in record time thanks to Ecoreal MV and Ecoreal Express.

Rapid ordering and delivery tracking

Use our dedicated online ordering tools and track your products deliveries or contact your local reseller.

Fast and fixed delivery

Schneider Electric makes sure that our available product inventory covers your needs. Our dedicated logistics ensures you get your referenced products when you need them.



Connect our Partner Portal to access your personal toolbox and complete information

Get access now to your personal toolbox

Get more than just products! You get enhanced level of support you have come to expect from Schneider Electric. Log in at our partner portal allows you to get access to your online toolbox with software to simplify your life at work and to stay up-to-date with all latest information you require on products, business and training.

- Discover product features and extended functionalities thru [eCatalog 3D Power](#)
- Configure and quote MV products using [Ecoreal MV and Express](#)
- Place a smooth order and track delivery progress in [mySchneider](#)

Make sure that our available product inventory covers your expectations thanks to our Partner Locator

Connected for efficiency and reliability

Trihal EcoStruxure™ ready



Connected Trihal

Trihal is now a proven product "EcoStruxure ready" for IoT age with connectivity built-in, providing 24/7 condition monitoring for an outstanding increase of safety & efficiency.

Through EcoStruxure, a complete asset management toolkit and suite of digital tools simplify the transition to predictive maintenance.

Temperature monitoring

Users can detect thermal effects early and take preventive actions. Alarms and warnings are delivered locally or remotely, as preferred.

EcoStruxure™ ready



Efficient asset management

Boost your efficiency and reduce downtime using **predictive** maintenance tools.



24/7 connectivity

Make better informed decisions with real-time data that's available **everywhere, anytime**.



Increased safety

Enhance your people and equipment's safety with **embedded arc flash** protection that's based on proven designs and experience.

Explore the connected Trihal

Access to online asset data from local HMI or remotely through cloud and dedicated apps, enabling faster and better decision making and helping to increase **operational efficiency**

Preventive maintenance thanks to assets driven by embedded smart and connected sensors and analytics. Enable to reduce downtime and Increase service continuity

OPEX optimization thanks to preventive maintenance assets driven by embedded smart and connected sensors, helping to reduce downtime

Safety for both operators and assets thanks to **embedded thermal effect detection**

Peace of mind from large and proven installed base with over 30 years of experience (>150 000 units)

Optimized lead time including all standard or optional connected devices

Helpful tools



eCatalog 3D app to facilitate product discovery

When purchasing a Trihal, providing a precise 3D model of Trihal, the eCatalog 3D application facilitates product discovery. Users can dismantle the device virtually, with options to move, rotate, and zoom. Opportunity to thoroughly examine product features helps customers make optimized purchasing decisions. The app is available for free download.

Click [here](#) to discover the eCatalog 3D



QR codes for fast answers

A QR code is available on each transformer.

Scanning the code with a mobile device (tablet, smartphone) with mySchneider app enables quick access to complete product information, including documentation, FAQs and access to our Customer Care Center (CCC).

A complimentary safe repository cloud storage, where all transformer-related documents can be stored for the entire product life, can also be accessed through the QR code

Safe repository for your asset!

<https://saferepository.schneider-electric.com/home>

Safe repository

What is a safe repository ?

A safe repository is a cybersecurity space asset, dedicated for all your asset life cycle documentations repository. Sharing community rights to up-load and down-load private documents.

[EcoDesign EU 548 documents repository](#)

In accordance with regulation the routine test certificate asset performance and CE certification web access.

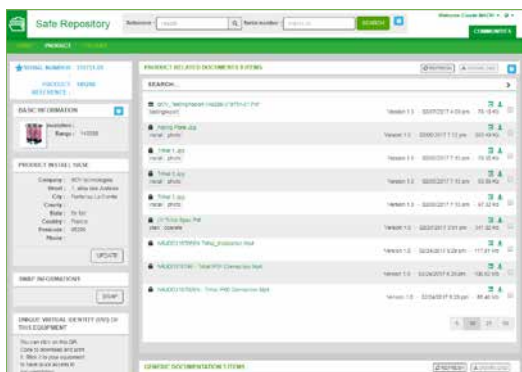

Pragmatic way to choose the right transformer!

<http://www.schneider-electric.com/en/tools/tco-for-transformer/>

Total Cost of Ownership (TCO)

When purchasing a transformer and especially when comparing two different solutions, the right choice is driven by an economic analysis of the equipment. Total Cost of Ownership, giving the cost of transformer operation throughout their life including purchasing, operating and maintenance costs.

Basically some simplification can be done when comparing two different transformers with the same technology: installation, maintenance and decommissioning will generate the same costs and then be excluded from the comparison.

The calculation has to take into consideration changes in the cost of energy during the transformer life span. The interest rate also has to be considered as stated below.

PM105927

Calculate TCO		Compare TCO (2)	
Compare TCO of Transformers			
	Units	Transformer 1 ★	Transformer 2 ✖
Product Family (Dry Type, Oil immersed or MPT/LPT):		DRY TYPE	
Rated Power:	kVA	1000	
Maximum HV insulation level:	kV	<=24	
Maximum LV insulation level:	kV	<=1.1	
No load losses Level:		AAAA	
Load losses Level:		Ak	
No load losses (PK):	W	890	2100
Load losses (PK):	W	9000	12000
Purchase price:	EUR	30000	25000
Transformer Total Cost of Ownership:	EUR	138484	190526
Payback Period Configuration coherence:	Yrs		1.42

[VIEW COMPARISON GRAPH](#)

Calculation of the TCO

The simplified calculation formula of the Total Cost of Ownership is as follows:

$$\text{Total Cost of Ownership} = \text{Purchasing Price} + \text{No-Load Losses Cost} + \text{Load Losses Cost}$$

With:

$$\text{No-Load Losses Cost: } NLLC = (1+i)^n - 1/i(1+i)^n * C * \text{Time}$$

$$\text{Load Losses Cost: } LLC = (1+i)^n - 1/i(1+i)^n * C * \text{Time} * \text{Load factor}^2$$

Where:

i: interest rate [%/year]

n: lifetime [years]

C: kWh price [USD/kWh]

Time: number of hours in a year [h/year] = 8760

Load factor: average load of the transformer during its life time

A unique opportunity to improve the key driver of the Building market
Still Interoperability is a challenge

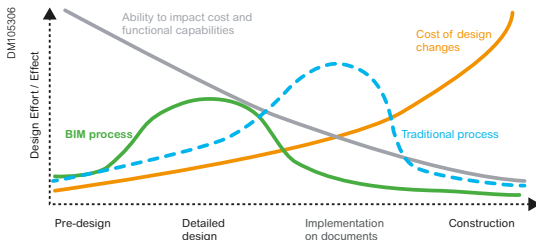

What is BIM

- BIM is an evolution of the Computer Aided Design (CAD) and modeling software market and key to digitization
- It improves on traditional CAD drawings by not only including geometry, but also information that helps in technical and budget calculations
- BIM also refers broadly to the collaborative processes between and or within companies to leverage the value of the models throughout the building design & lifecycle
- Helps create, construct, manage and operate projects more economically and with less environmental impact

Customer requirements



Business

- High value business



Efficiency

- Reduce time and effort required for work.
- Pain: disconnected tools and incapability to share and interact with each other



Collaboration

- Project management across multiple design environment, colleagues and stakeholders is inefficient and not productive.
- Pain: no collaborative platform to support seamless experience for electrical industry to perform electrical tasks and share across companies and geographies.

Benefits of BIM

- Save time on designs
- Decrease project costs
- Improves co-ordination and collaboration
- Minimizes risk
- Helps to easily maintain building lifecycle

BIM and the Building Lifecycle

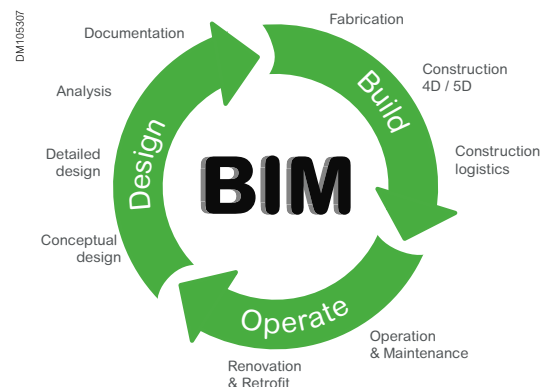

Trihal BIM repositories

- **Trihal Eco-Design transformer:**
<https://bimobject.com/en-us/schneider/product/trihal-eco>
- **Trihal non Eco-Design transformers:**
<https://bimobject.com/en-us/schneider/product/sch-trihal-01>

Web and services

schneider-electric.com

This international web site allows you to access all the Schneider Electric solutions and product information via:

- Comprehensive descriptions
- Range datasheets
- A download area
- Product selectors

You can also access information dedicated to your business and contact your Schneider Electric country support.

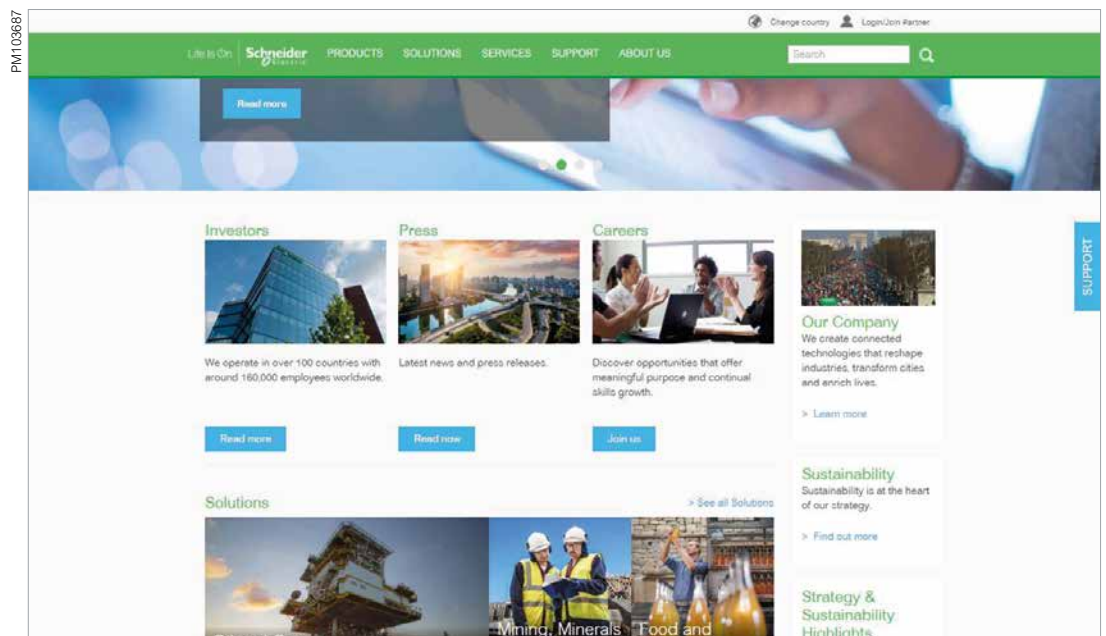

Training

Training allows you to acquire the expertise (installation design, work with power on, etc.) to increase efficiency and improve customer service.

The training catalog includes beginner's courses in electrical distribution, knowledge of MV and LV switchgear, operation and maintenance of installations, and design of transformers to give a few examples.

Annex

Annex

Other Trihal characteristics	62
Trihal Up to 3150 kVA - 12 kV - B ₀ B _k	62
Trihal Up to 3150 kVA - 12 kV - C ₀ C _k	63
Trihal Up to 3150 kVA - 17.5 kV to 24 kV - A ₀ A _k	64
Trihal Up to 3150 kVA - 17.5 kV to 24 kV - B ₀ B _k	65
Trihal Up to 3150 kVA - 17.5 kV to 24 kV - C ₀ B _k	66
Trihal Up to 3150 kVA - 36 kV - B ₀ B _k	67
Trihal Up to 3150 kVA - 36 kV - C ₀ C _k	68
Trihal for NX1/SCB13	69
Trihal for NX2/SCB12	70

Trihal - Cast Resin Transformer Up to 3150 kVA - 12 kV - C3 E3 F1 5pC

Main electrical characteristics

Power kVA	100	160	250	400	400	630	630	800	1000	1250	1600	2000	2500	3150
Primary voltage	10kV													
Secondary voltage	400V between phases, 231V phase to neutral (at no load)													
HV insulation level	12kV													
HV tapping range	± 2.5 % and/or ± 5 %													
Vector group	Dyn 11, Dyn 5, Dyn 1 (other vector groups upon request)													
No-load losses (w)	330	450	610	880	880	1150	1150	1300	1500	1800	2200	2600	3200	3800
Load losses at 75°C (w)	1700	2300	3100	4300	4300	6400	6400	7850	8800	10500	12600	15700	18300	22600
Load losses at 120°C (w)	2000	2700	3500	4900	4900	7300	7300	9000	10000	12000	14500	18000	21000	26000
Impedance voltage (%)	4	4	4	4	6	6	4	6	6	6	6	6	6	6
Acoustic Level dB(A):														
- power L _{WA}	51	54	57	60	60	62	62	65	67	69	71	73	75	77
- pressure L _{PA} (1m)	39	42	45	47	47	49	49	51	51	53	54	54	54	54

Dimensions* and weights

Without enclosure (IP00)

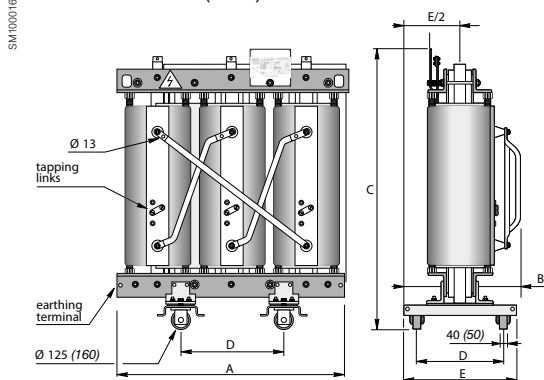

With IP31 metal enclosure

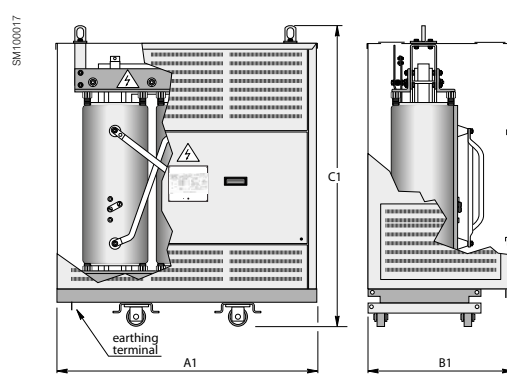

Rated power (kVA)		100	160	250	400	400	630	630	800	1000	1250	1600	2000	2500	3150
Without enclosure IP00															
Dimensions (mm)	-A	1020	1040	1120	1200	1250	1390	1350	1380	1510	1560	1670	1800	1940	2090
	-B	650	650	650	800	800	800	820	800	950	950	950	1200	1200	1200
	-C	1260	1300	1320	1510	1470	1550	1700	1780	1720	1860	2030	2160	2200	2600
	-D	520	520	520	670	670	670	670	670	820	820	820	1070	1070	1070
	-E	715	715	715	795	795	795	795	795	945	945	945	1195	1195	1195
Total weight (kg)		680	800	1000	1360	1260	1740	1920	1940	2320	2680	3280	4120	5300	7360
With IP31 metal enclosure															
Dimensions (mm)	-A1	1650	1650	1650	1700	1700	1700	1800	1800	2000	2000	2000	2330	2330	2450
	-B1	950	950	950	1020	1020	1020	1020	1020	1170	1170	1170	1270	1270	1290
	-C1	1750	1750	1750	1900	1900	1900	2050	2050	2400	2400	2400	2650	2650	2980
Weight enclosure (kg)		180	180	180	190	190	190	210	210	260	260	260	330	330	400
Total weight (kg)		860	980	1180	1550	1450	1930	2130	2150	2580	2940	3540	4450	5630	7780

* see page 18 all available Trihal technical range

Trihal - Cast Resin Transformer Up to 3150 kVA - 12 kV - C3 E3 F1 5pC

Main electrical characteristics

Power kVA	100	160	250	400	400	630	630	800	1000	1250	1600	2000	2500	3150
Primary voltage	10kV													
Secondary voltage	400V between phases, 231V phase to neutral (at no load)													
HV insulation level	12kV													
HV tapping range	± 2.5 % and/or ± 5 %													
Vector group	Dyn 11, Dyn 5, Dyn 1 (other vector groups upon request)													
No-load losses (w)	440	610	820	1150	1150	1500	1500	1800	2100	2500	2800	3600	4300	5300
Load losses at 75°C (w)	1700	2300	3100	4300	4300	6400	6400	7900	8800	10500	12600	15700	18300	22600
Load losses at 120°C (w)	2000	2700	3500	4900	4900	7300	7300	9000	10000	12000	14500	18000	21000	26000
Impedance voltage (%)	4	4	4	4	6	4	6	6	6	6	6	6	6	6
Acoustic Level dB(A):														
- power L _{WA}	59	62	65	68	68	70	70	71	73	75	76	78	81	83
- pressure L _{PA} (1m)	47	50	53	55	56	57	57	59	59	61	61	61	61	61

Dimensions* and weights

Without enclosure (IP00)

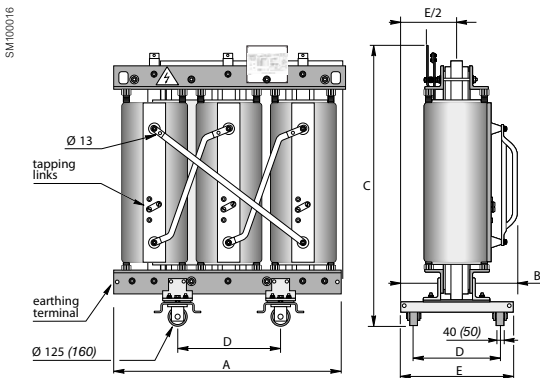

With IP31 metal enclosure

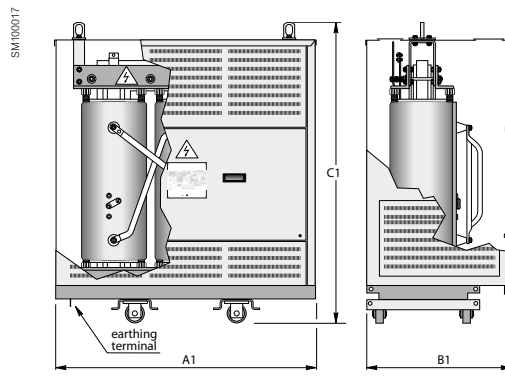

Rated power (kVA)		100	160	250	400	400	630	630	800	1000	1250	1600	2000	2500	3150
-------------------	--	-----	-----	-----	-----	-----	-----	-----	-----	------	------	------	------	------	------

Without enclosure IP00

Dimensions (mm)	-A	1050	1080	1180	1335	1375	1450	1440	1510	1525	1605	1665	1760	1850	2070
	-B	650	650	650	795	795	820	815	835	945	945	945	1195	1195	1195
	-C	1200	1250	1260	1350	1330	1530	1550	1670	1675	1860	2035	2180	2360	2550
	-D	520	520	520	670	670	670	670	670	820	820	820	1070	1070	1070
	-E	715	715	715	795	795	795	795	795	945	945	945	1195	1195	1195
Total weight (kg)		650	750	960	1240	1210	1640	1740	2040	2125	2580	3210	3910	4480	6000

With IP31 metal enclosure

Dimensions (mm)	-A1	1650	1650	1650	1700	1700	1700	1700	1700	2000	2000	2150	2330	2330	2500
	-B1	950	950	950	1020	1020	1020	1020	1020	1170	1170	1170	1270	1270	1290
	-C1	1750	1750	1750	1900	1900	1900	1900	1900	2400	2400	2480	2650	2650	2800
Weight enclosure (kg)		160	160	170	190	190	190	190	190	265	265	325	370	370	400
Total weight (kg)		810	910	1130	1430	1400	1830	1930	2230	2390	2845	3535	4280	4850	6400

* see page 18 all available Trihal technical range

Trihal - Cast Resin Transformer Up to 3150 kVA - 17.5 to 24 kV - C3 E3 F1 5pC

Main electrical characteristics

Power kVA	100	160	250	315	400	500	630	800	1000	1250	1600	2000	2500	3150
Primary voltage	15 or 20kV													
Secondary voltage	400 to 433V between phases, 231 to 250V phase to neutral (at no load)													
HV insulation level	17.5kV for 15kV - 24kV for 20kV													
HV tapping range	± 2.5 % and/or ± 5 %													
Vector group	Dyn 11, Dyn 5, Dyn 1 (other vector groups upon request)													
No-load losses (w)	280	400	520	630	750	900	1100	1300	1550	1800	2200	2600	3100	3800
Load losses at 75°C (w)	1620	2340	3060	3510	4050	5130	6390	7200	8100	9900	11700	14400	17100	19800
Load losses at 120°C (w)	1800	2600	3400	3900	4500	5700	7100	8000	9000	11000	13000	16000	19000	22000
Impedance voltage (%)	6	6	6	6	6	6	6	6	6	6	6	6	6	6
Acoustic Level dB(A):														
- power L _{WA}	51	54	57	59	60	61	62	64	65	67	68	70	71	74
- pressure L _{PA} (1m)	39	42	45	46	47	48	49	50	51	53	53	55	56	58

Dimensions* and weights

Without enclosure (IP00)

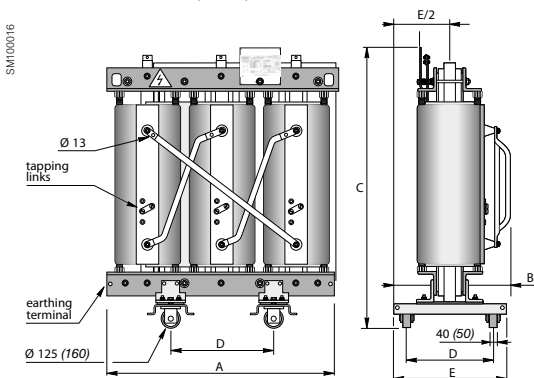

With IP31 metal enclosure

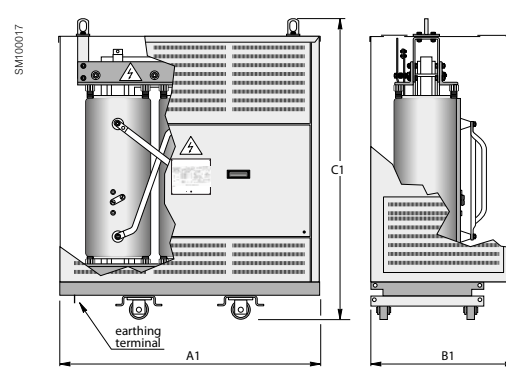

Rated power (kVA)		100	160	250	315	400	500	630	800	1000	1250	1600	2000	2500	3150
Without enclosure IP00															
Dimensions (mm)	-A	1290	1260	1330	1350	1410	1430	1500	1660	1660	1710	1790	1880	2070	2280
	-B	720	720	720	800	800	800	800	800	950	950	950	1200	1200	1200
	-C	1370	1370	1430	1580	1600	1620	1640	1810	1950	2100	2340	2420	2480	2660
	-D	520	520	520	670	670	670	670	670	820	820	820	1070	1070	1070
	-E	715	715	715	795	795	795	795	795	945	945	945	1195	1195	1195
Total weight (kg)		940	930	1200	1360	1580	1660	1920	2550	2790	3200	4000	4950	6160	8370
With IP31 metal enclosure															
Dimensions (mm)	-A1	1650	1650	1650	1700	1700	1800	1800	2000	2000	2150	2330	2330	2470	2680
	-B1	950	950	950	1020	1020	1020	1020	1170	1170	1170	1240	1270	1240	1310
	-C1	1750	1750	1750	1900	1900	2050	2050	2400	2400	2480	2650	2650	2880	3060
Weight enclosure (kg)		180	180	180	190	190	210	210	245	245	320	370	370	350	360
Total weight (kg)		1120	1110	1380	1550	1770	1870	2130	2795	3035	3520	4370	5320	6510	8730

* see page 18 all available Trihal technical range

Trihal - Cast Resin Transformer Up to 3150 kVA - 17.5 to 24 kV - C3 E3 F1 5pC

Main electrical characteristics

Power kVA	160	250	400	630	800	1000	1250	1600	2000	2500	3150
Primary voltage	15 or 20kV										
Secondary voltage	400V to 433V between phases, 231 to 250V phase to neutral (at no load)										
HV insulation level	17.5kV for 15kV - 24kV for 20kV										
HV tapping range	± 2.5 % and/or ± 5 %										
Vector group	Dyn 11, Dyn 5, Dyn 1 (other vector groups upon request)										
No-load losses (w)	480	650	940	1250	1500	1800	2100	2400	3000	3600	4300
Load losses at 75°C (w)	2550	3300	4800	6650	8200	9600	11300	14000	15650	20000	24350
Load losses at 120°C (w)	2900	3800	5500	7600	9400	11000	13000	16000	18000	23000	28000
Impedance voltage (%)	6	6	6	6	6	6	6	6	6	6	6
Acoustic Level dB(A):											
- power L _{WA}	54	57	60	62	64	65	67	68	70	71	74
- pressure L _{PA} (1m)	42	45	47	49	50	51	51	51	51	51	51

Dimensions* and weights

Without enclosure (IP00)

With IP31 metal enclosure

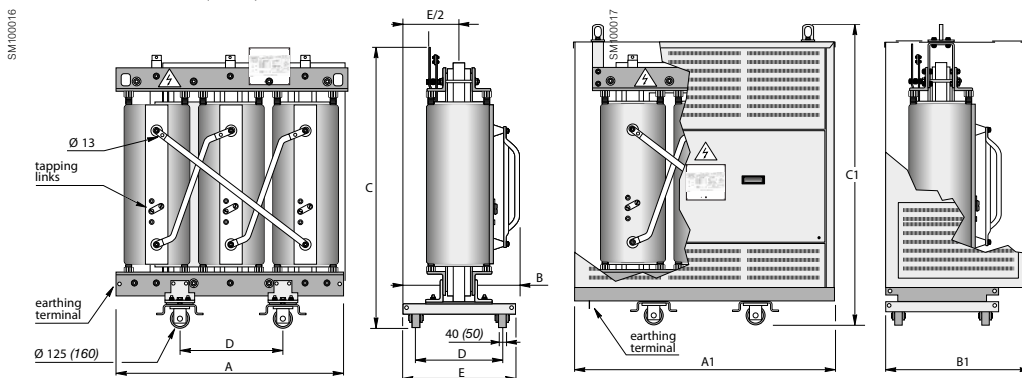

Rated power (kVA)		160	250	400	630	800	1000	1250	1600	2000	2500	3150
Without enclosure IP00												
Dimensions (mm)	-A	1300	1350	1440	1570	1585	1620	1655	1795	1840	2085	2260
	-B	720	715	810	835	840	945	945	945	1195	1195	1200
	-C	1370	1355	1465	1640	1770	1940	2080	2200	2440	2500	2660
	-D	520	520	670	670	670	820	820	820	1070	1070	1070
	-E	715	715	795	795	795	945	945	945	1195	1195	1195
Total weight (kg)		950	1060	1500	2040	2300	2640	3160	4075	4900	5800	8150
With IP31 metal enclosure												
Dimensions (mm)	-A1	1650	1650	1700	1800	1800	2000	2150	2150	2330	2360	2620
	-B1	950	950	1020	1020	1020	1170	1170	1170	1270	1270	1290
	-C1	1750	1750	1900	2050	2050	2400	2480	2480	2650	2800	3100
Weight enclosure (kg)		180	180	190	210	210	260	320	320	370	370	400
Total weight (kg)		1130	1240	1690	2250	2510	2900	3480	4395	5270	6170	8550

* see page 18 all available Trihal technical range

Trihal - Cast Resin Transformer Up to 3150 kVA - 17.5 to 24 kV - C3 E3 F1 5pC

Main electrical characteristics

Power kVA	160	250	400	630	800	1000	1250	1600	2000	2500	3150
Primary voltage	15 or 20kV										
Secondary voltage	400V between phases, 231V phase to neutral (at no load)										
HV insulation level	17.5kV for 15kV - 24kV for 20kV										
HV tapping range	± 2.5 % and/or ± 5 %										
Vector group	Dyn 11, Dyn 5, Dyn 1 (other vector groups upon request)										
No-load losses (w)	650	880	1200	1650	2000	2300	2800	3100	4000	5000	6000
Load losses at 75°C (w)	2550	3300	4800	6600	8200	9600	11300	14000	15700	20000	24400
Load losses at 120°C (w)	2900	3800	5500	7600	9400	11000	13000	16000	18000	23000	28000
Impedance voltage (%)	6	6	6	6	6	6	6	6	6	6	6
Acoustic Level dB(A):											
- power L _{WA}	62	65	68	70	72	73	75	76	78	81	83
- pressure L _{PA} (1m)	50	53	56	57	59	60	61	62	63	66	67

Dimensions* and weights

Without enclosure (IP00)

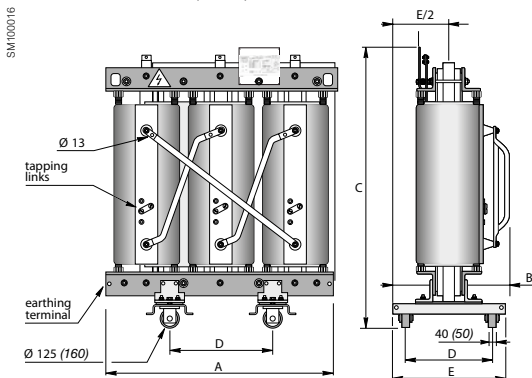

With IP31 metal enclosure

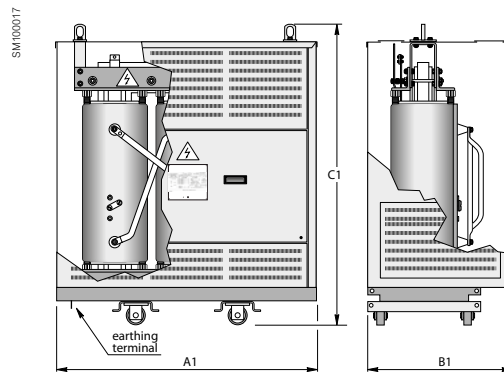

Rated power (kVA)		160	250	400	630	800	1000	1250	1600	2000	2500	3150
Without enclosure IP00												
Dimensions (mm)	-A	1300	1330	1410	1480	1555	1645	1645	1735	1860	2025	2200
	-B	710	715	805	820	830	850	850	955	975	1000	1200
	-C	1335	1345	1435	1740	1760	1800	2070	2120	2310	2355	2410
	-D	520	520	670	670	670	820	820	820	1070	1070	1070
	-E	715	715	795	795	795	945	945	945	1195	1195	1195
Total weight (kg)		860	990	1320	1820	2060	2560	2920	3355	4080	5080	6770
With IP31 metal enclosure												
Dimensions (mm)	-A1	1650	1650	1700	1800	1800	1900	1900	2150	2330	2320	2500
	-B1	950	950	1020	1020	1020	1025	1100	1170	1240	1240	1290
	-C1	1750	1750	1900	2050	2050	2050	2300	2480	2650	2650	2650
Weight enclosure (kg)		180	180	190	210	210	240	240	320	375	375	400
Total weight (kg)		1040	1170	1510	2030	2270	2800	3160	3675	4455	5455	7170

* see page 18 all available Trihal technical range



Trihal - Cast Resin Transformer Up to 3150 kVA - 36 kV - C3 E3 F1 5pC

Main electrical characteristics

Power kVA	160	250	400	630	800	1000	1250	1600	2000	2500	3150
Primary voltage	De 28.5 à 34.5 kV										
Secondary voltage	400V entre phases, 231V entre phase et neutre (sans charge)										
HV insulation level	36kV										
HV tapping range	± 2.5 % and/or ± 5 %										
Vector group	Dyn 11, Dyn 5, Dyn 1 (other vector groups upon request)										
No-load losses (w)	900	1100	1300	1600	1900	2250	2600	3000	3500	4200	5000
Load losses at 75°C (w)	2350	3310	4700	6530	7830	9570	11310	13920	16090	19570	23920
Load losses at 120°C (w)	2700	3800	5400	7500	9000	11000	13000	16000	18500	22500	27500
Impedance voltage (%)	6	6	6	6	6	6	6	6	6	6	6
Acoustic Level dB(A):											
- power L _{WA}	62	64	65	68	69	70	72	73	74	78	81
- pressure L _{PA} (1m)	49	51	52	54	55	55	57	58	58	62	65

Dimensions* and weights

Without enclosure (IP00)

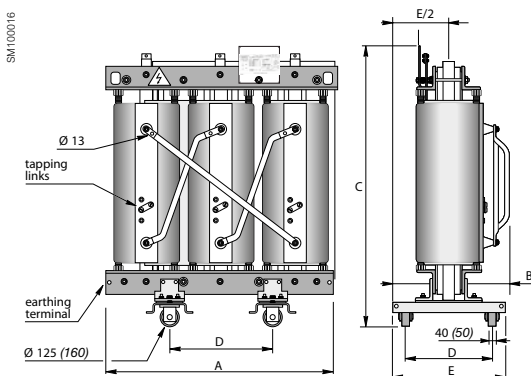

With IP31 metal enclosure

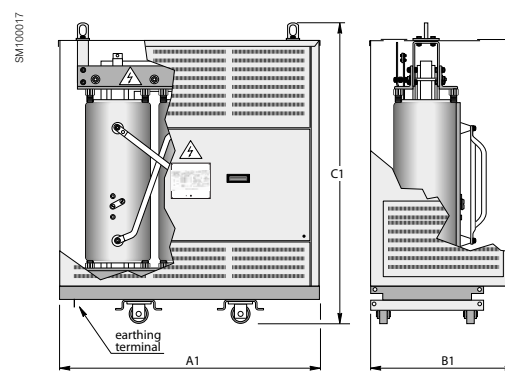

Rated power (kVA)	160	250	400	630	800	1000	1250	1600	2000	2500	3150
-------------------	-----	-----	-----	-----	-----	------	------	------	------	------	------

Without enclosure IP00

Dimensions (mm)	-A	1480	1450	1470	1560	1740	1750	1790	1850	1980	2120	2370
	-B	800	790	870	880	920	990	1000	1010	1200	1200	1220
	-C	1730	1750	1790	1970	2030	2180	2220	2440	2540	2580	2710
	-D	520	520	670	670	670	820	820	820	1070	1070	1070
	-E	715	715	795	795	795	945	945	945	1195	1195	1195
Total weight (kg)	1380	1480	1680	2130	2880	3160	3520	4200	5460	6090	7840	

With IP31 metal enclosure

Dimensions (mm)	-A1	2080	2050	2070	2160	2340	2350	2390	2450	2580	2720	2970
	-B1	1220	1210	1220	1240	1310	1310	1320	1340	1390	1430	1520
	-C1	2030	2050	2090	2270	2330	2480	2520	2740	2940	2980	3110
Weight enclosure (kg)	200	200	200	300	300	300	300	400	400	400	400	
Total weight (kg)	1580	1680	1880	2430	3180	3460	3820	4600	5860	6490	8240	

* see page 18 all available Trihal technical range

Trihal - Cast Resin Transformer Up to 3150 kVA - 36 kV - C3 E3 F1 5pC

Main electrical characteristics

Power kVA	250	400	630	800	1000	1250	1600	2000	2500	3150
Primary voltage	28.5 to 34.5 kV									
Secondary voltage	400V between phases, 231V phase to neutral (at no load)									
HV insulation level	36kV									
HV tapping range	± 2.5 % and/or ± 5 %									
Vector group	Dyn 11, Dyn 5, Dyn 1 (other vector groups upon request)									
No-load losses (w)	1280	1650	2200	2700	3100	3600	4200	5000	5800	6700
Load losses at 75°C (w)	3500	5000	7000	8400	10000	12200	14800	18300	21800	26100
Load losses at 120°C (w)	4000	5700	8000	9600	11500	14000	17000	21000	25000	30000
Impedance voltage (%)	6	6	6	6	6	6	6	6	6	6
Acoustic Level dB(A):										
- power L _{WA}	67	69	71	72	73	75	76	78	81	83
- pressure L _{PA} (1m)	55	56	57	58	59	61	61	63	61	61

Dimensions* and weights

Without enclosure (IP00)

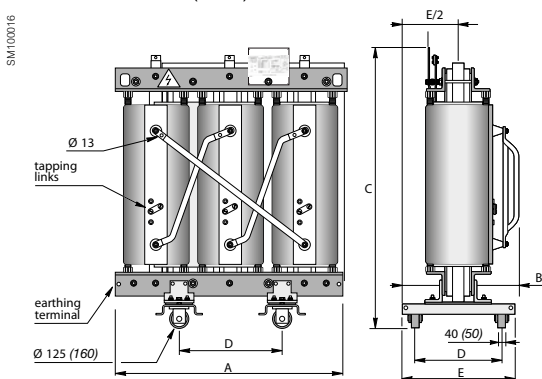

With IP31 metal enclosure

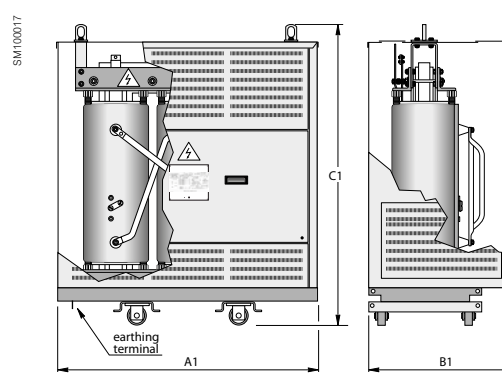

Rated power (kVA)		250	400	630	800	1,000	1,250	1,600	2,000	2,500	3,150
Without enclosure IP00											
Dimensions (mm)	-A	1,460	1,460	1,530	1,660	1,740	1,780	1,850	1,970	2,270	2,400
	-B	790	870	870	870	950	950	950	1,200	1,200	1,200
	-C	1,750	1,790	1,950	1,990	2,160	2,200	2,400	2,500	2,460	2,750
	-D	520	670	670	670	820	820	820	1,070	1,070	1,070
	-E	715	795	795	795	945	945	945	1,195	1,195	1,195
Total weight (kg)		1,460	1,600	2,000	2,400	2,910	3,280	3,920	4,900	6,580	8,280
With IP31 metal enclosure											
Dimensions (mm)	-A1	2,060	2,060	2,130	2,260	2,340	2,380	2,450	2,570	2,870	3,000
	-B1	1,210	1,210	1,230	1,280	1,300	1,320	1,340	1,380	1,480	1,530
	-C1	2,050	2,090	2,250	2,290	2,460	2,500	2,700	2,800	2,860	3,150
Weight enclosure (kg)		200	200	300	300	300	320	400	400	350	450
Total weight (kg)		1,660	1,800	2,300	2,700	3,210	3,600	4,320	5,300	6,930	8,730

* see page 18 all available Trihal technical range

Trihal characteristics for NX1/SCB13 series

Main electrical characteristics

Power kVA	315	400	500	630	630	800	1000	1250	1600	2000	2500
Primary voltage	6, 6.3, 6.6, 10, 10.5, 11kV										
Secondary voltage at no load	400V / 415V / 433V										
HV insulation level	7.2 kV for 6 kV class, 12 kV for 10 kV class										
HV tapping range	± 2 x 2.5 %										
Frequency	50 Hz										
Max ambient temperature	40°C										
Vector group	Dyn 11 (other vector groups upon request)										
No-load losses (w)	635	705	835	965	935	1095	1275	1505	1765	2195	2590
Load losses at 120°C (w)	3125	3590	4390	5290	5365	6265	7315	8720	10555	13005	15455
Impedance voltage (%)	4	4	4	4	6	6	6	6	6	6	6
No-load current	0.5	0.4	0.4	0.4	0.4	0.3	0.3	0.3	0.2	0.2	0.2
Acoustic Level dB(A): pressure L _{PA} (1m)	38	40	40	40	40	40	44	44	45	45	45

Dimensions* and weights

Without enclosure

Outline drawing

Installation holes

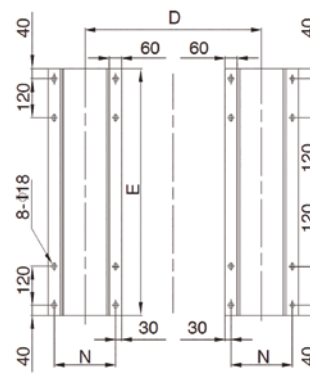
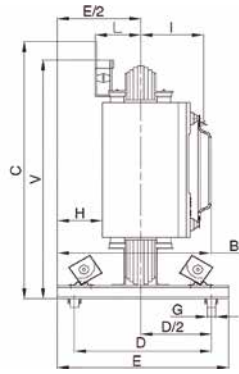
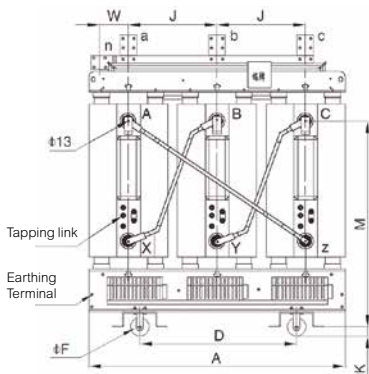

Power kVA	315	400	500	630	630	800	1000	1250	1600	2000	2500
Dimension	1218	1242	1365	1431	1482	1554	1566	1731	1794	1911	2178
B	795	795	807	945	945	1070	1070	1070	1070	1195	1195
C	1526	1541	1556	1606	1571	1666	1751	1876	2016	2091	2131
D	660	660	660	660	660	820	820	820	820	1070	1070
E	795	795	795	945	945	1070	1070	1070	1070	1195	1195
F	125	125	125	125	125	160	160	160	160	160	200
G	40	40	40	40	40	50	50	50	50	50	70
H	212	208	188	251	243	293	291	263.5	255	298	251.5
I	386	390	410	422	430	442	444	472	480	500	546
J	406	414	455	477	494	518	522	577	598	637	726
L	193	194	214	222	233	242	239	269	258	267	315
M	1030	1040	1050	1080	1060	1090	1190	1240	1380	1410	1330
N	240	240	240	240	240	310	310	310	310	310	310
W	173	177	187	198	207	199	201	218	229	238	278
V	1466	1481	1476	1526	1491	1566	1651	1756	1896	1951	1961
LV Terminal	a	a	b	b	b	c	c	d	d	e	f
Weight	1660	1720	2110	2520	2680	3180	3400	4390	5210	6040	7960

* see page 18 all available Trihal technical range

Trihal characteristics for NX2/SCB12 series

Main electrical characteristics

Power kVA	315	400	500	630	630	800	1000	1250	1600	2000	2500
Primary voltage	6, 6.3, 6.6, 10, 10.5, 11kV										
Secondary voltage at no load	400V / 415V / 433V										
HV insulation level	7.2 kV for 6 kV class, 12 kV for 10 kV class										
HV tapping range	± 2 x 2.5 %										
Frequency	50 Hz										
Max ambient temperature	40°C										
Vector group	Dyn 11 (other vector groups upon request)										
No-load losses (w)	705	785	930	1070	1040	1215	1415	1670	1960	2440	2880
Load losses at 120°C (w)	3470	3990	4880	5880	5960	6960	8130	9690	11730	14450	17170
Impedance voltage (%)	4	4	4	4	4	6	6	6	6	6	6
No-load current	0.6	0.5	0.5	0.5	0.4	0.4	0.4	0.4	0.3	0.3	0.3
Acoustic Level dB(A): pressure L _{PA} (1m)	42	42	44	44	44	44	46	46	46	48	48

Dimensions* and weights

Without enclosure

Outline drawing

Installation holes

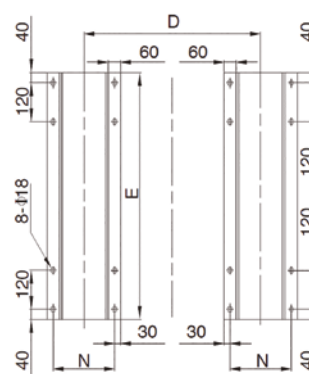
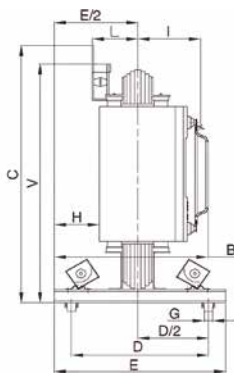
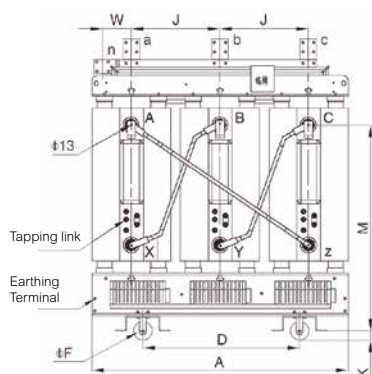

Power kVA		315	400	500	630	630	800	1000	1250	1600	2000	2500
Dimension	A	1182	1233	1320	1374	1374	1479	1563	1677	1767	1845	1959
	B	795	795	799	810	810	945	1070	1070	1070	1070	1195
	C	1446	1556	1556	1561	1541	1611	1731	1816	1891	2046	2326
	D	660	660	660	660	660	820	820	820	820	1070	1070
	E	795	795	795	795	795	945	1070	1070	1070	1070	1195
	F	125	125	125	125	125	125	160	160	160	160	160
	G	40	40	40	40	40	40	50	50	50	50	50
	H	217.5	209	196	185.5	185.5	243	291.5	272.5	257.5	246.5	290
	I	380	388	402	412	412	430	444	462	478	488	508
	J	394	411	440	458	458	493	521	559	589	615	653
	L	189	191	226	219	205	231	229	257	263	278	269
	M	950	1040	1050	1050	1040	1060	1180	1210	1250	1380	1580
	N	240	240	240	240	240	240	310	310	310	310	310
	W	167	175	180	189	189	196	210	219	234	237	241
	V	1740	1740	1720	1720	1720	1900	1900	2080	2080	2260	2230
LV Terminal		a	a	b	b	b	c	c	d	d	e	f
Weight		1430	1730	1860	2360	2130	2590	3310	3910	4710	5480	7010

* see page 18 all available Trihal technical range

Terminals for NX1/SCB13 & NX2/SCB12 series

LV terminals

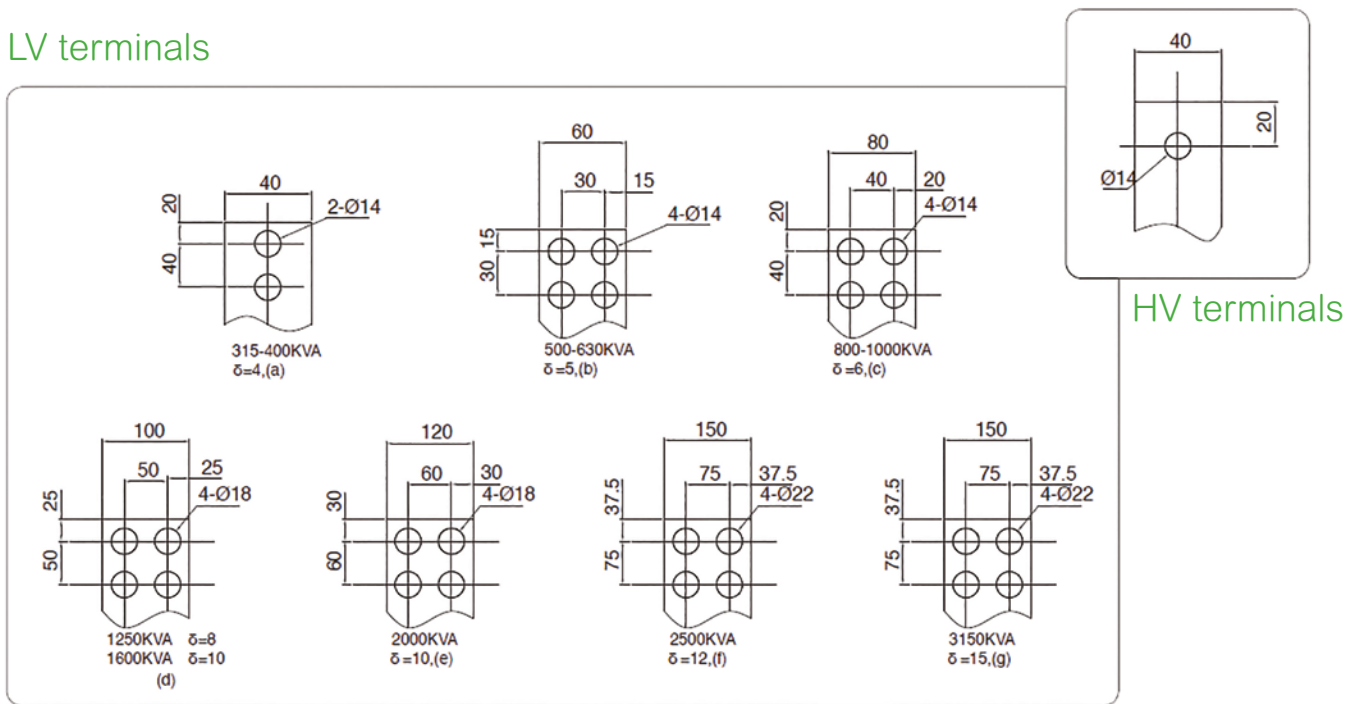

Schneider Electric Industries SAS

35 rue Joseph Monier
92500 Rueil-Malmaison, France
Tel : +33 (0)1 41 29 70 00

www.schneider-electric.com

SAS capital social 928 298 512 €
954 503 439 RCS Nanterre

03, 04, 2018
NRJED315663EN

©2018 Schneider Electric. All Rights Reserved.
All trademarks are owned by Schneider Electric Industries SAS or its affiliated companies.