

Arado Ar. (E) 555

Anfang 1944 begannen auf Anordnung des Technischen Amtes des Reichsluftfahrtministeriums (RLM) bei den Arado-Werken in Landeshut/Schlesien die Entwurfsarbeiten für ein Langstrecken- und Hochgeschwindigkeitsflugzeug. Nach einer Besprechung am 20. April 1944 legte man sich auf ein Nurfüglflugzeug fest das eine Reichweite von 4800 km und eine Höchstgeschwindigkeit von 860 km/h erreichen sollte. Als Bombenlast wurden verschiedene Abwurfaffen bis zu einer maximalen Zuladung von 4000 kg verlangt. Als Defensivbewaffnung wurden je 2 Rheinmetall-Borsig MK 103, Kaliber 30 mm, vorn in den Tragflächen-vorderkanten, sowie je 2 Maser MG 151/20, Kaliber 20 mm, in einem Drehturm auf der Rumpfböerseite und -unterseite vorgesehen. Die Steuerung der Drehtürme erfolgte durch ein ausfahrbares Periskop im druckbelüfteten Besatzungsraum, der bis zu drei Mann aufnehmen sollte. Als Hauptfahrwerk war ein, nach innen einziehbares, Tandem - Fahrwerk mit jeweils 4 Laufrädern pro Seite und ein kleineres Bugfahrwerk mit zwei Laufrädern vorgesehen. Der Antrieb bestand aus 6 BMW 003A Jet-Triebwerken die auf dem Rumpfrücken, paarweise versetzt, auf gleicher Höhe nebeneinander angeordnet waren. Die gleichen Triebwerke wurden auch später im Serienbau der Arado Ar 234C und der Heinkel He 162 verwendet. Am 23. Dezember 1944 wurden, wegen der Kriegslage und fehlender Rohstoffe, auf Anweisung des Reichsluftfahrtministeriums alle weiteren Arbeiten eingestellt.

Heute gilt die Arado Ar 555 zusammen mit der Go 229, von der noch eine Maschine im Smithsonian Institution in Washington D.C. erhalten ist, als die erste Generation der Stealth-Flugzeuge. So erinnert die Northrop B-2 Spirit in vielen Bereichen an die Ar 555. So zum Beispiel die Ausführung der Fahrwerke und ihre ähnlichen überdimensionierten Hauptfahrwerkstrüme, der Besatzungsraum und die Anordnung der Triebwerke. Wie hervorragend die Stealth-Eigenschaften dieser Flugzeuge waren hat Northrop 2009 im Auftrag des National Geographic Channel selbst durch einen großen Radarvergleichstest belegt. Eine in Originalgröße (1:1) gebaute Go 229 wurde im Northrop Test Center auf einen Pylon montiert und mit Radargeräten ausgemessen. Dabei ergaben sich um mehr als 20% geringere Reflexionseigenschaften gegenüber konventionellen Flugzeugen, was die Vorwarnzeiten um mehr als die Hälfte reduziert hätte. (Nur noch 8 statt 19 Minuten) Als „Amerika-Bomber“ - wie sie oft bezeichnet wird - wäre die Arado Ar 555 nicht geeignet gewesen. Bei einer Reichweite von „nur“ 5000 Kilometer hätte es kaum bis nach New York gereicht - die Entfernung Frankfurt/Main - New York beträgt 6200 km.

Technische Daten:

Spannweite	20.90 m
Länge	15.85 m
Höhe	5.00 m
Motoren	6 x BMW 003A
Leistung	je 800 kp
Leergewicht	15 680 kg
Startgewicht	24 000 kg
Landegeschwindigkeit	165 km/h
Höchstgeschwindigkeit	860 km/h
Reisegeschwindigkeit	620 km/h
Dienstgipfelhöhe	15 000 m
Reichweite	4 800 km
Bewaffnung	2 x MK 103 Tragflächenvorderkante 2 x MG 151/20 Drehturm 2 x MG 151/20 in Drehturm unter Rumpf
Bombenladung	4 000kg
Besatzung	3 Mann

Arado Ar. (E) 555

Early in 1944 on a directive from the Technical Office of the Imperial Aviation Ministry, the Arado plant in Landshut/Silesia began design of an aircraft with the capabilities of high-speed and long-range. After a meeting on 20 April 1944, it was decided to use the flying wing concept. The aircraft should achieve a range of 4800 km (2980 miles) and a top speed of 860 km/h (534 mph). As the Bomb-load, a variety of weapons were to be carried up to a maximum payload of 4000 kg (8820 lbs). For the defensive armament it was envisaged to install two Rheinmetall-Borsig 30 mm calibre MK 103's in the leading edges of the wing and 2 twin Maser 20 mm calibre MG 151/20's in turrets above and below the fuselage. The turrets were to be controlled via a retractable periscope from a pressure-ventilated crew room which was to accommodate up to three crewmen. As the main undercarriage an inwardly retractable tandem arrangement with 4 wheels per side was envisaged with a smaller nose gear with two wheels. The power unit consisted of 6 BMW 003A jet engines mounted on the upper fuselage. They were located in pairs, placed side by side with the outer pairs displaced slightly aft. Similar engines were also used later in the mass production of the Arado Ar 234C and Heinkel He 162. On 23 December 1944 due to the War and the lack of raw materials, all further work was discontinued on instructions from the Imperial Aviation Ministry. Today, the Arado Ar 555 together with the Go 229, another aircraft preserved in the Smithsonian Institute in Washington DC, is considered to be a first generation Stealth Aircraft. The Northrop B-2 Spirit is similar to the Ar 555 in many of its features. The undercarriage design for example, with its over-dimensioned main gear doors, the crew compartment and the engine arrangement. In 2009 on behalf of the National Geographic Channel, Northrop itself tested how good the stealth characteristics of these aircraft were in an extensive radar comparison test. At the Northrop Test Centre a Go 229 was built to the original size (1:1), mounted on a pylon and its radar returns were measured. The results indicated more than 20% lower reflection rates when compared with conventional aircraft, which would have reduced detection times by more than half (Only 8 instead of 19 minutes). As the „America Bomber“ - as it is often referred to - the Arado Ar 555 would not have been suitable. With a range of „only“ 5000 km (3100 miles) it would not have reached New York - the distance between Frankfurt/Main and New York is 6200 km (3850 miles).

Technical Data:

Wingspan	20.90 m (68ft 6ins)
Length	15.85 m (52ft 0ins)
Height	5.00 m (16ft 5ins)
Engines	6 x BMW 003A
Power	each 800 kp
Empty Weight	15 680 kg (34574 lbs)
Take-off Weight	24 000 kg (52920 lbs)
Landing Speed	165 km/h (102 mph)
Maximum Speed	860 km/h (534 mph)
Cruising Speed	620 km/h (385 mph)
Service Ceiling	15 000 m (49200 ft)
Range	4 800 km (2980 miles)
Armament	2 x MK 103 Wing Leading Edge 2 x MG 151/20 Rotating Turret 2 x MG 151/20 in a Rotating Turret under the Fuselage
Bomb Load	4000 kg (8820 lbs)
Crew	3

Form hergestellt und in Eigentum von Revell GmbH & Co. KG. Widerrechtliche Nachahmungen werden gerichtlich verfolgt.
Ce produit est propriété de la société Revell GmbH & Co. KG. Toute utilisation ou duplication frauduleuse fera l'objet de poursuites en justice.
Modelado y en propiedad de Revell GmbH & Co. KG. Imitaciones ilícitas serán perseguidas por la ley.
Forma prodotta dalla Revell GmbH & Co. KG. e di proprietà della stessa impresa. La quale procederà legalmente contro ogni imitazione abusiva.
Malli on Revell GmbH & Co. KG. valmistama ja omaisuutta. Laittomaan kopiointiin tullaan puuttamaan oikeudellisin toimin.
Formen er produsert og er av Revell GmbH & Co. KG. Etterfigning uten tillatelse vil bli gjenstand for rettslig forfølgelse.
Produkcia i prawa własności firmy Revell GmbH & Co. KG. In egjalne podrabianie jest zabronione pod odpowiedzialnością sądową.
Model Revell GmbH & Co. KG. firmasının mülkiyeti altında imal edilmiştir. Kanuna aykırı taklidler mahkemeye takip edilecektir.
A forma előállítását és a tulajdonjog betekosát a Revell GmbH & Co. KG. A jogellenes utáratókat és hamisítványokat bírósággal üldözök. Üldözök.

Mould manufactured by and property of Revell GmbH & Co. KG. illegal imitations are subject to prosecution.
Vorm vervaandigt door en eigendom van Revell GmbH & Co. KG. Onrechtmatige nabootsingen worden gerechtelijk vervolgd.
Formas produzidas e de propriedade da Revell GmbH & Co. KG. Cópias não autorizadas serão processadas juridicamente como determinado na lei.
Modellen tillverkad av och tillhör Revell GmbH & Co. KG. All kopiering beivras enligt lagen om upphovsrätt.
Formen er fremstillet af Revell GmbH & Co. KG. som også her ejendommen. Lovstridige efterfigninger sagsøges.
Modela azotowana i własności przedsiębiorstwa firmy Revell GmbH & Co. KG. Przetwarzanie kopii bez zezwolenia jest surowo zabronione.
Η μορφή κατασκευάστηκε και διατίθεται στην ιδιοκτησία της Revell GmbH & Co. KG. Οι παρανομιές διπλής θα καταδιωχθούν δικαστικώς.
Tva byl vyroben a vlastní Revell GmbH & Co. KG. a je její vlastností. Všechny nezákonné napodobňování se bude posturovat souduí cestou.
Forma je proizvedena in je vlasništvo Revell GmbH & Co. KG. Neovlašćene kopije bodo pravno kažnjene.

Verwendete Symbole / Used Symbols

Bitte beachten Sie folgende Symbole, die in den nachfolgenden Baustufen verwendet werden. Veuillez noter les symboles indiqués ci-dessous, qui sont utilisés dans les étapes suivantes de montage. ...

Please note the following symbols, which are used in the following construction stages. Neem a.u.b. de volgende symbolen in acht, die in de onderstaande bouwfases worden gebruikt. ...



Abziehbild in Wasser einweichen und anbringen. Soak and apply decals. Mouiller et appliquer les décalcomanies. ...



Zur Anbringung der Abziehbilder empfohlen. Recommended for affixing the decals. Recommandé pour l'application des décalcomanies. ...



Kleben. Glue. Coller. Lijmen. Engomar. ...



Nicht kleben. Don't glue. Ne pas coller. Niet lijmen. ...



Wahlweise. Optional. Facultatif. Naar keuze. ...



Klebeband. Adhesive tape. Dévidoir de ruban adhésif. Plakband. ...



Klarsichtteile. Clear parts. Pièces transparentes. Transparente onderdelen. ...



Gleichen Vorgang auf der gegenüberliegenden Seite wiederholen. Repeat same procedure on opposite side. Opérer de la même façon sur l'autre face. ...



Abbildung zusammengesetzter Teile. Illustration of assembled parts. Figure représentant les pièces assemblées. ...



Mit einem Messer abtrennen. Detach with knife. Détacher au couteau. Met een mesje afsnijden. ...



Bauteile trocken lassen. Allow the parts to dry. Laisser sécher les pièces. Oderdelen laten drogen. ...



Anzahl der Arbeitsgänge. Number of working steps. Nombre d'étapes de travail. Het aantal bewerkingen. ...

* Nicht enthalten / Behoort niet tot de levering / Não incluído / Ikke inkluderet / Hei eiðilukkeret / Nie zawiera. ...

Beiliegenden Sicherheitstext beachten / Please note the enclosed safety advice

D: Beiliegenden Sicherheitstext beachten und nachschlagbereit halten. GB: Please note the enclosed safety advice and keep safe for later reference. F: Respecter les consignes de sécurité ci-jointes et les conserver à portée de main. ...

Dieser Bausatz wurde in mehrfachen Qualitäts- und Gewichtskontrollen auf Vollständigkeit überprüft. Reklamationen können nur bearbeitet werden, wenn die Bauanleitung, das aus der Kartonage herausgeschchnittene EAN-Strichcode-Feld und der Kassenbono eingeschickt werden. ...

Afin de vous donner entière satisfaction et pour nous assurer que tous les éléments nécessaires au montage de votre maquette sont présents dans la boîte, cet article a subi dans son intégralité divers contrôles qualitatifs ainsi que des contrôles de poids. ...

This Model Kit has been subject to extensive quality and weight checks during the manufacturing process to ensure it leaves our warehouse in perfect condition. We are only able to process applications for missing parts if the following procedure is followed. ...

Deze bouwdoos werd verscheidene malen volledig gecontroleerd op kwaliteit en gewicht. Klachten kunnen slechts in behandeling worden genomen indien de bouwhandleiding, de uit de doos geknipte EAN-streepjescode en de kassabon zijn meegezonden. ...

Benötigte Farben / Used Colors

Benötigte Farben Required colours	Peintures nécessaires Benodigde kleuren	Pinturas necesarias Tintas necessárias	Colori necessari Använda färger	Tarvittavat värit Du trenger følgende farger	Nødvendige farger Необходимые краски	Potrzebne kolory Απαιτούμενα χρώματα	Gerekli renkler Potřebné barvy	Szükséges színek. Potrebne barve
A	B	C	D	E	F	G		
anthrazit, matt 9 anthracite grey, matt anthracite, mat antraciet, mat antracita, mate antracite, fosco antracite, opaco antracit, matt antrasiti, himmeä koksgrå, mat antrasitt, matt антрацит, матовый antracyt, matowy ανθρακί, ματ antrasit, mat antracit, matná antracit, matt tamno siva, matt	staubgrau, matt 77 dust grey, matt gris poussière, mat stolgrijs, mat ceniciento, mate cinzento de pó, fosco grigio sabbia, opaco dammgrå, matt pölynharmaa, himmeä stovgrå, mat stovgrå, matt серый пыльный, матовый szary kurz, matowy χρῶμα σκόνης, ματ toz grisi, mat prachově šedá, matná porszürke, matt prah siva, mat	aluminium, metallic 99 aluminium, metallic aluminium, métallique aluminium, metallic aluminio, metalizado aluminio, metálico alluminio, metallico aluminium, metallic aluminium, metalliskt aluminium, metallak aluminium, metallic алюминиевый, металл aluminium, metaliczny ολουμινίου, μεταλλικό aluminium, metalik hliníková, metaliza aluminium, metall aluminium, metalik	lederbraun, matt 84 leather brown, matt brun cuir, mat lederbruin, mat marrón cuero, mate castanho couro, fosco marrone cuoio, opaco läderbrun, matt nahkanuskea, himmeä läderbrun, mat läzbrun, matt коричневая кожа, матовый brunatny jak skóra, matowy καφέ δέρματος, ματ deri kahverengi, mat koženě hnědá, matná börbarna, matt koža rjava, mat	panzergrau, matt 78 tank grey, matt gris blindé, mat pansergrijs, mat plomioz, mate cinzento militar, fosco color carro armato, opaco pansargrå, matt panssarinharmaa, himmeä kampvogngrå, mat pansergrå, matt серый танк, матовый szary czolg., matowy γκρι ταנקς, ματ panzer grisi, mat páncéřové šedá, matná páncéřszürke, matt oklopno siva, mat	helloliv, matt 45 light olive, matt olive clair, mat olijf-licht, mat aceítuna, mate oliva claro, opaco ljusoliv, matt valsean oliivi, himmeä lysoliv, mat lys oliven, matt светло-оливковый, матовый jasnooliwk., matowy ανοιχτό χακί, ματ açik zeytuni, mat světleolivová, matná világos oliv, matt svetlo oliva, mat	Schwarzgrün, matt 40 Black green, matt Vert noir, mat Zwartgroen, mat Negro verdoso, mate Verde-preto, mate Nero verde, opaco Svartgrön, matt Mustanvihreä, matta Sortgrön, mat Sortgrön, matt Черно-зеленый, матовый Czarnozielony, matowy Πρασινόχλωρο, ματ Siyah yeşili, mat Feketeszöld, matt Černozelená, matná Črnazelena, brez leska		
90 %	10 %	90 %	10 %	J	K	L	M	N
Hellblau, matt 49 + Light blue, matt Bleu clair, mat Lichtblau, mat Azul claro, mate Azul-claro, mate Blu chiaro, opaco Ljusblå, matt Vaaleansininen, matta Lyseblå, mat Lysblå, matt Светло-синий, матовый Jasnoniebieski, matowy Μπλε ανοιχτό, ματ Açik mavi, mat Világoskék, matt Svĕtle modrá, matná Svetlomodra, brez leska	weiß, matt 5 white, matt blanc, mat wit, mat blanco, mate branco, fosco bianco, opaco vit, matt valkoinen, himmeä hvid, mat hvit, matt белый, матовый biały, matowy λευκό, ματ beyaz, mat bílá, matná fehér, matt bela, mat	blaugrau, matt 79 + greyish blue, matt gris-bleu, mat blauwgrijs, mat gris azulado, mate cinzento azulado, fosco grigio blu, opaco blågrå, matt siniharmaa, himmeä blågrå, mat blågrå, matt сине-серый, матовый sivý, matowy γκριζομπλέ, ματ mavi gri, mat modrosedá, matná kékesszürke, matt plavo siva, mat	weiß, matt 5 white, matt blanc, mat wit, mat blanco, mate branco, fosco bianco, opaco vit, matt valkoinen, himmeä hvid, mat hvit, matt белый, матовый biały, matowy λευκό, ματ beyaz, mat bílá, matná fehér, matt bela, mat	karmirod, matt 36 carmin red, matt rouge carmin, mat karmijnrood, mat carmin, mate vermelho carmin, fosco rosso carminio, opaco karmirod, matt karmiinpunainen, himmeä karmirod, mat karmirod, matt красный кармин, матовый karmirovy, matowy κόκκινο όδιήθδ, ματ lái rengi, mat krbově červená, matná kárminpiros, matt šminka rdeča, mat	laubgrün, seidenmatt 364 leaf green, silky-matt vert feuille, satiné mat bladgroen, zijdemat verde follaje, mate seda verde gaio, fosco sedoso verde foglia, opaco seta lövgroen, sidenmatt lehdenvihreä, silkkihimmeä løvgrøn, silkematt løvgrønn, silkematt лиственно-зеленый, шелк.-матовый zielony liściasty, jedwabisto-matowy πράσινο φυλλωμάτων, μεταξ, ματ yaprak yeşili, ipek mat zelená jako listí, hedvábně matná lombzöld, selyemmatt list zelena, svila mat	gelb, matt 15 yellow, matt jaune, mat geel, mat amarillo, mate amarelo, fosco giallo, opaco gul, matt keltainen, himmeä gul, mat gul, matt желтый, матовый žółty, matowy κίτρινο, ματ sari, mat žlutá, matná sárga, matt rumena, mat	hellgrau, seidenmatt 371 light grey, silky-matt gris clair, satiné mat lichtgrijs, zijdemat gris claro, mate seda cinzento claro, fosco sedoso grigio chiaro, opaco seta ljusgrå, sidenmatt vaaleanharmaa, silkkihimmeä lysegrå, silkematt lysgrå, silkematt светло-серый, шелковисто-матовый jasnoszary, jedwabisto-matowy ανοιχτό γκρι, μεταξωτό ματ açik gri, ipek mat světlešedá, hedvábně matná világosszürke, selyemmatt svetlo siva, svila mat	weiß, matt 5 white, matt blanc, mat wit, mat blanco, mate branco, fosco bianco, opaco vit, matt valkoinen, himmeä hvid, mat hvit, matt белый, матовый biały, matowy λευκό, ματ beyaz, mat bílá, matná fehér, matt bela, mat



zur besseren Ausbalancierung mit einem Gewicht beschweren
Add weight for improved stability
Pour une mise en place correcte allourdir
Voor evenwicht gewicht aanbrengen
Colocar un peso para obtener un mejor equilibrio
Utilizar um peso para melhor balanceamento
Per un migliore bilanciamento metterci su un peso
belasta med en vikt för bättre balansering
paremman tasapainon saavuttamiseksi kuormita painolla
Til bedre afbalancering vedhænges en vægt
For bedre afbalancering - belast med en vekt
для лучшего отбалансирования положить груз
dla lepszego wyważenia obciążyc ciężarkiem
για την καλύτερη αντιστάθμιση τοποθετείστε ένα βάρος
Daha iyi dengelemek için bir ağırlık koyun
Za účelem lepšího vyvážení zatížit závažím
a jobb kiegyenlítés érdekében egy nehezéssel ellátni
Zaradi boljše ravnoteže postaviti kontratežo z tegom

Nicht enthalten
Not included
Non fourni
Behoort niet tot de levering
No incluido
Non compresi
Não incluído
Ikke medsendt
Ingår ej
Ikke inkludert
Eivät sisälly
Δεν ομπεριλαμβάνεται
He содержит
Nem tartalmazza
Nie zawiera
Ni vsebovano
İçerisinde bulunmamaktadır
Neni obsaženo

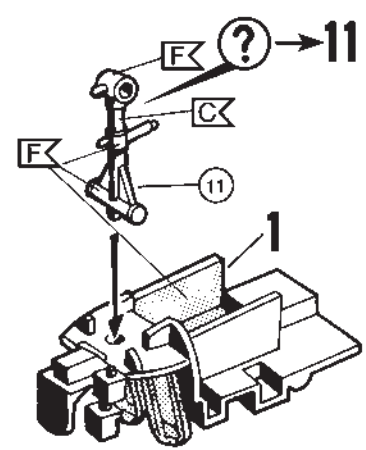
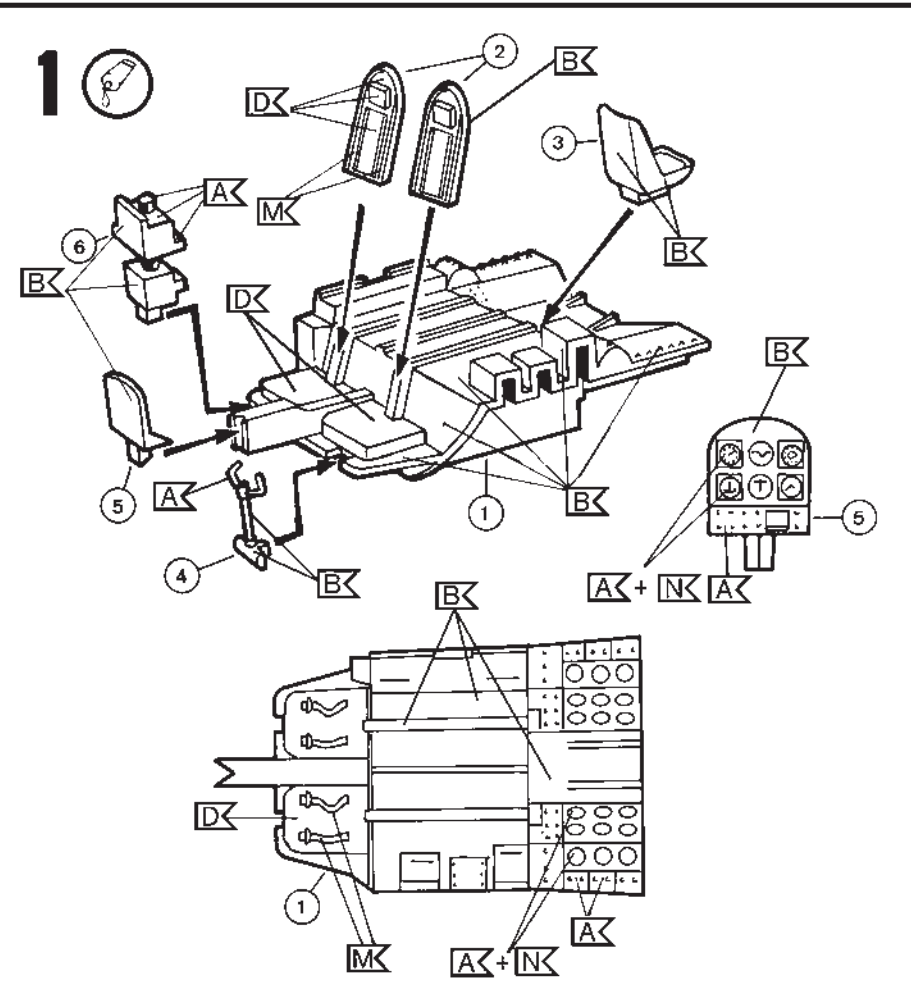
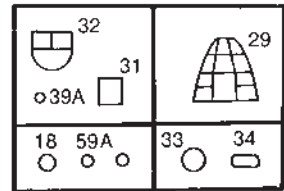
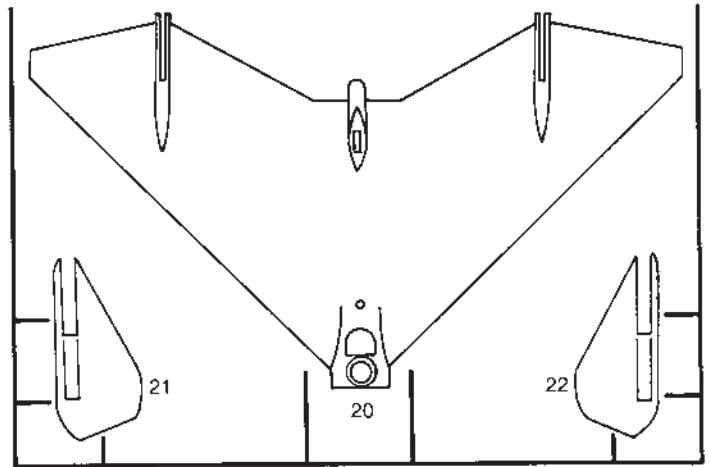
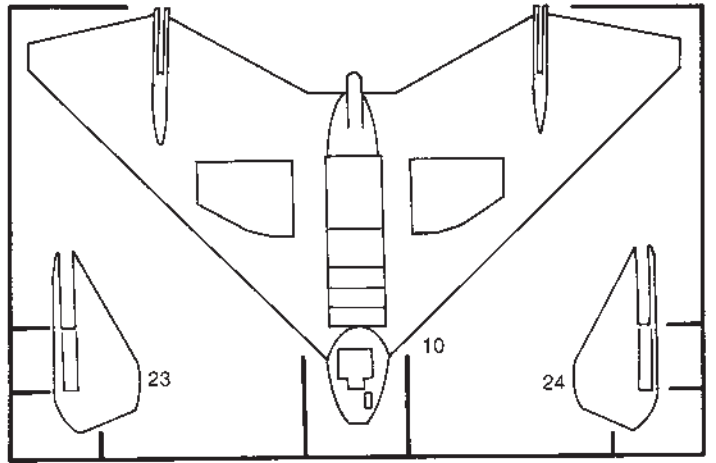
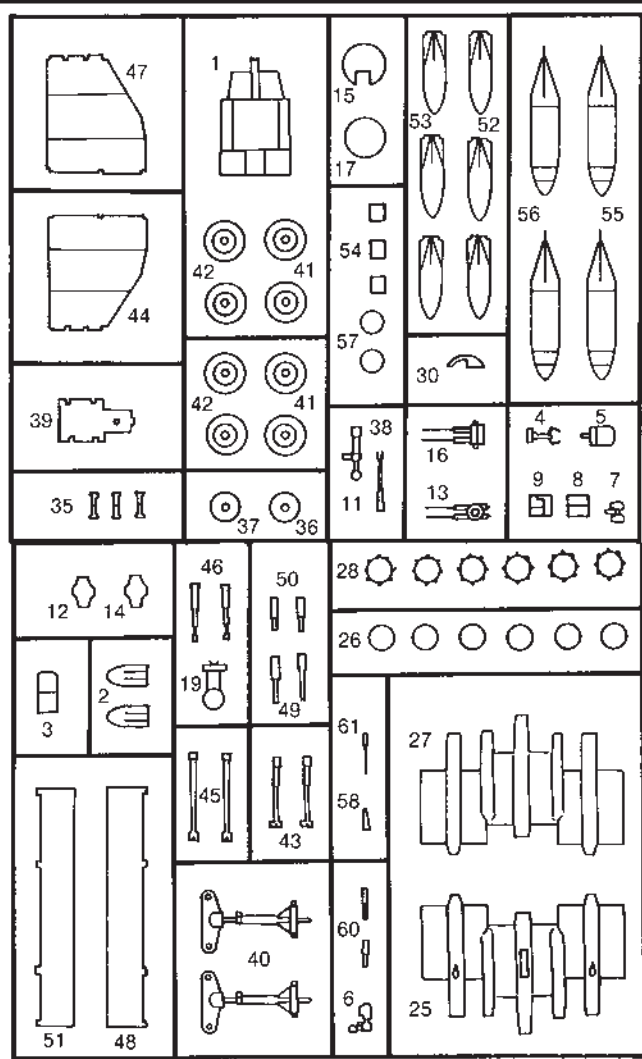

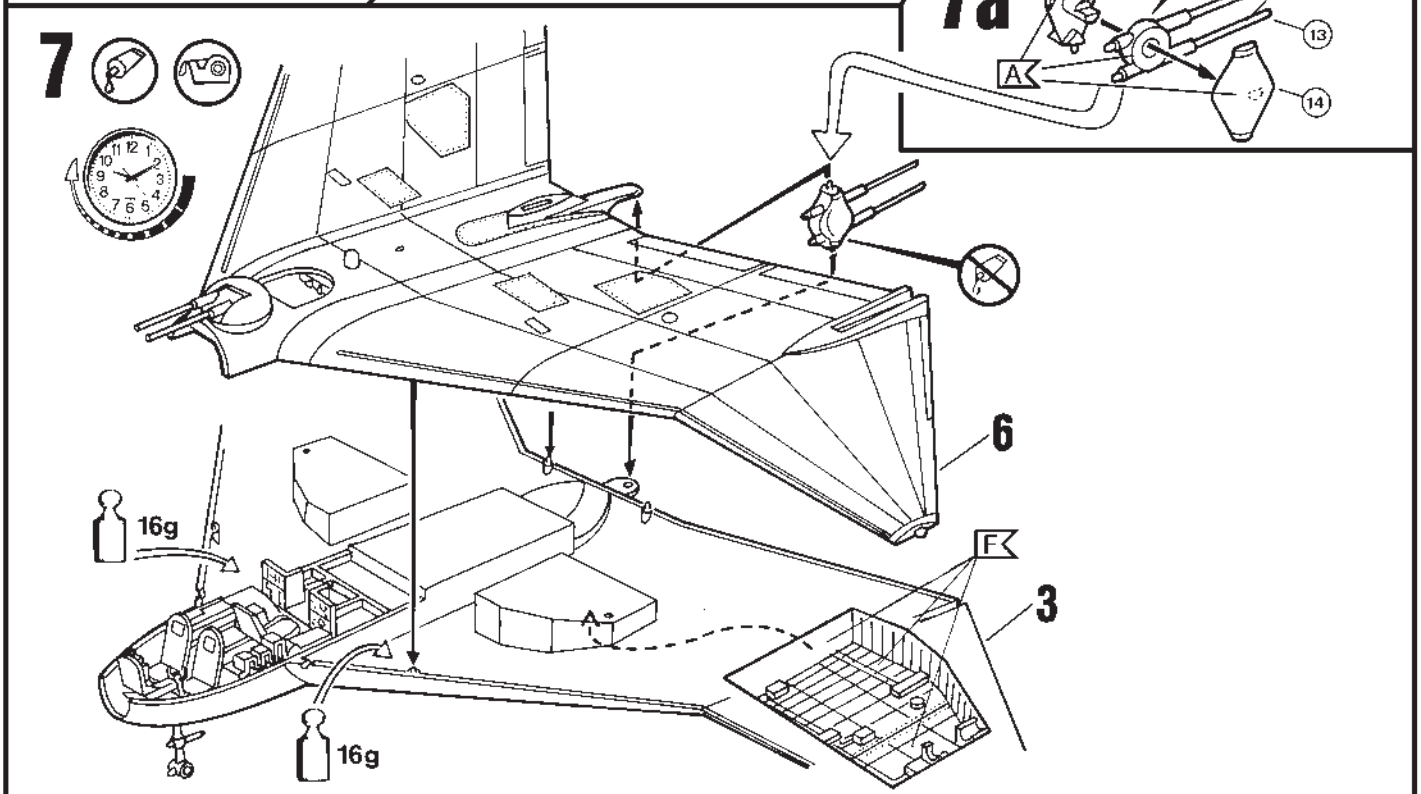
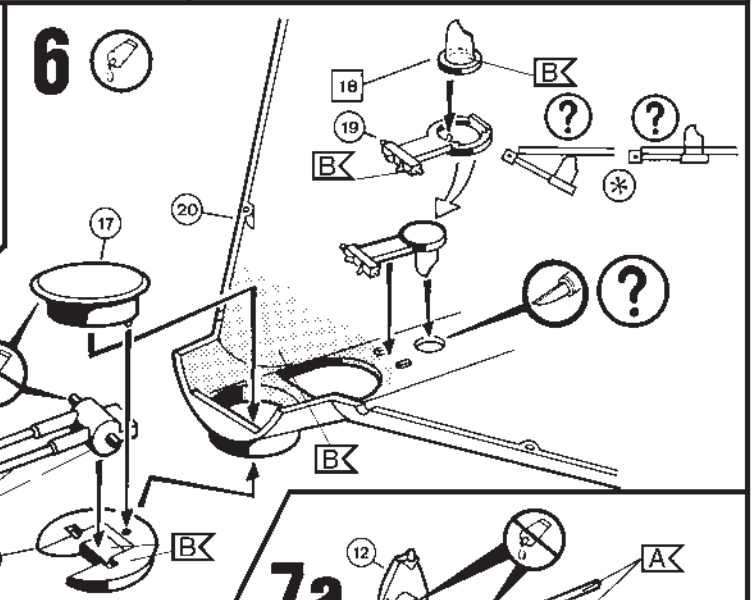
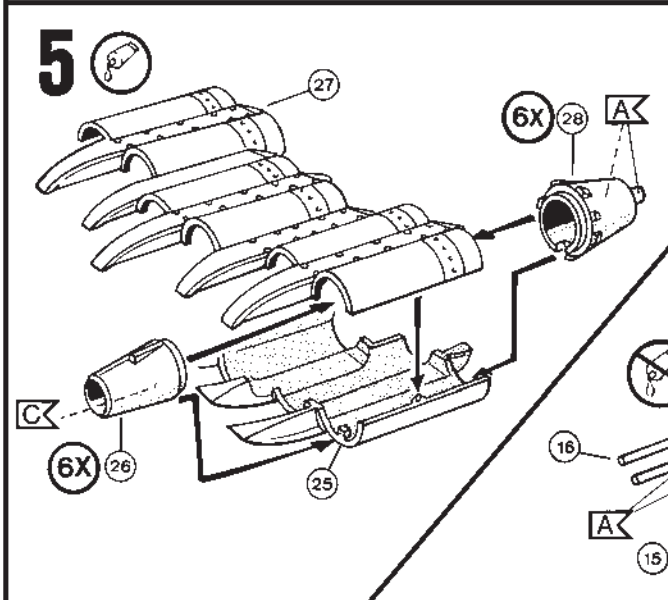
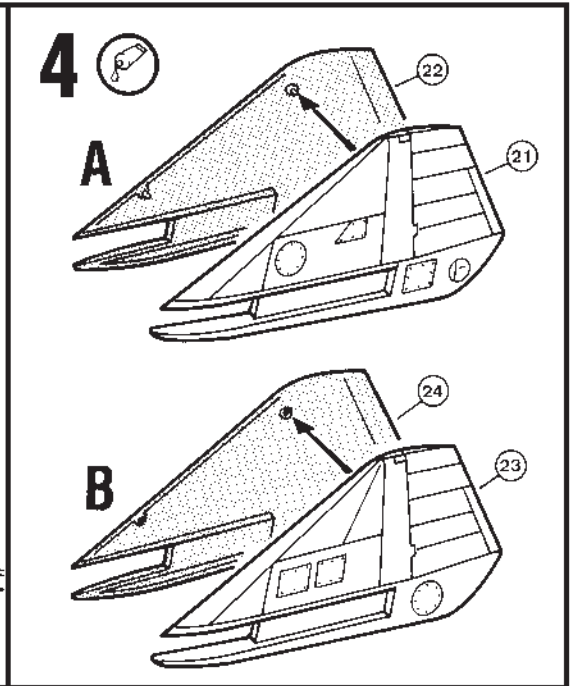
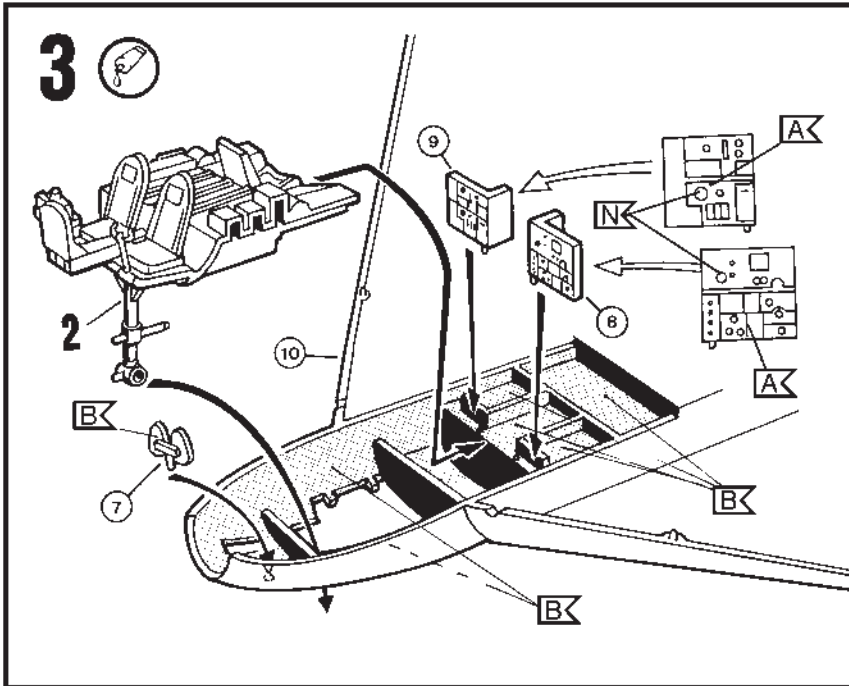

8

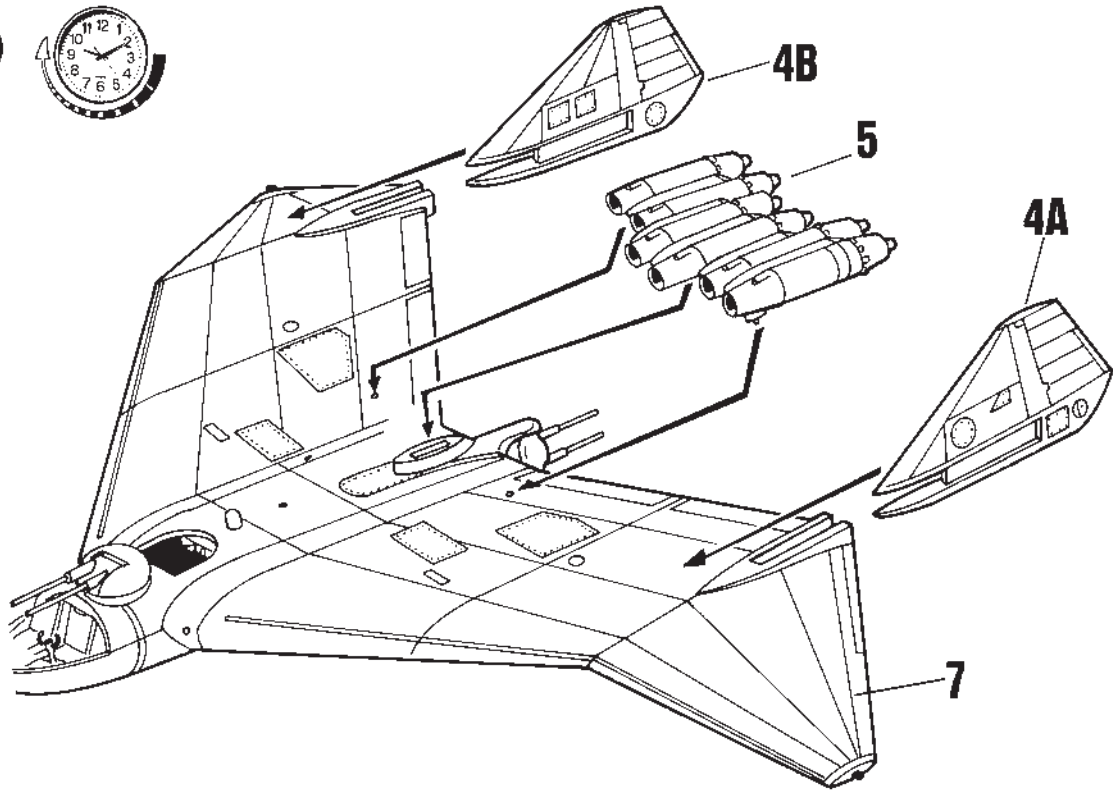

9

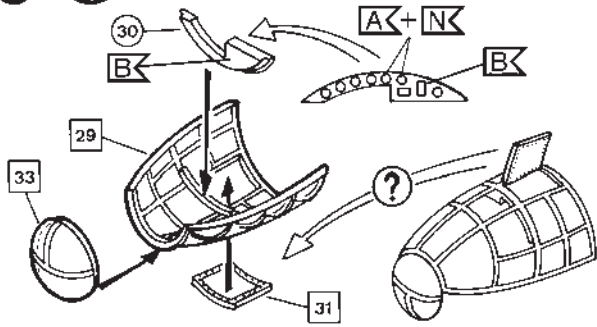

10

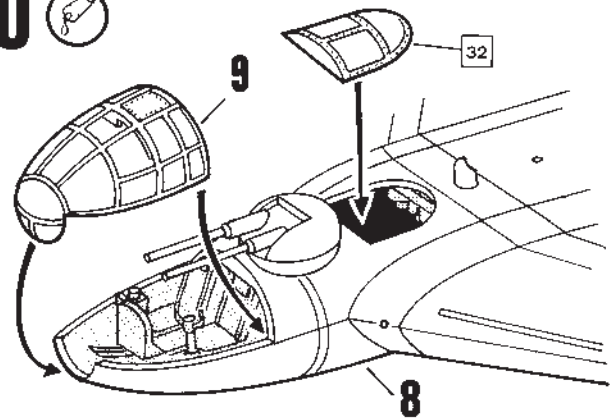

11

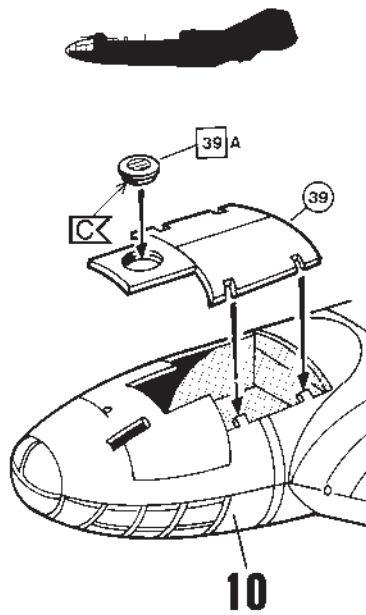

12

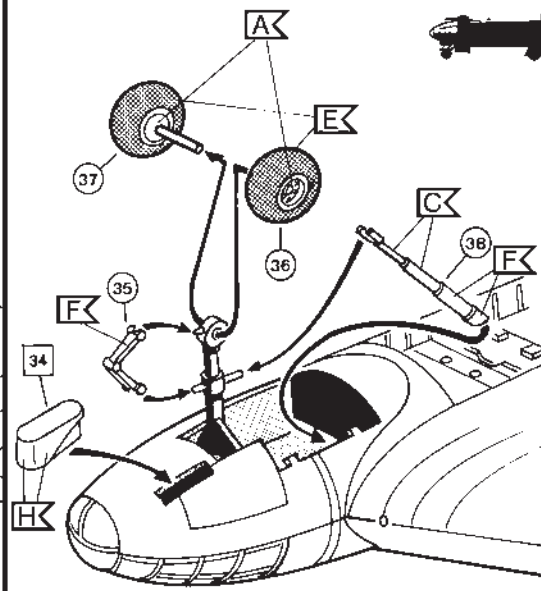

13

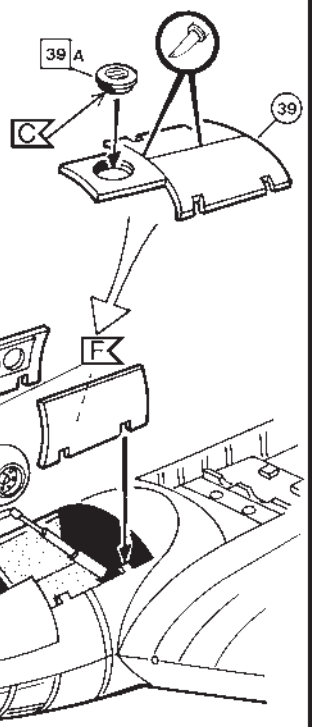

14



left

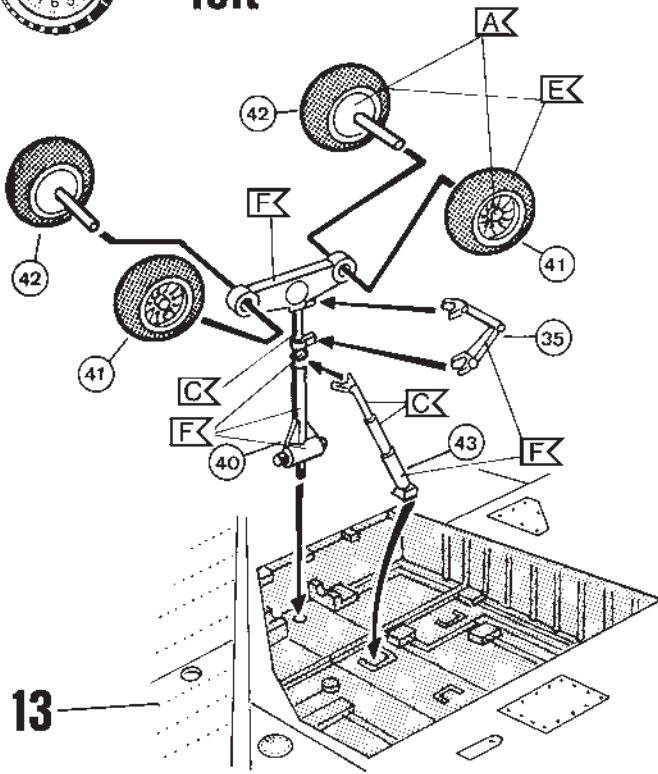

15



left

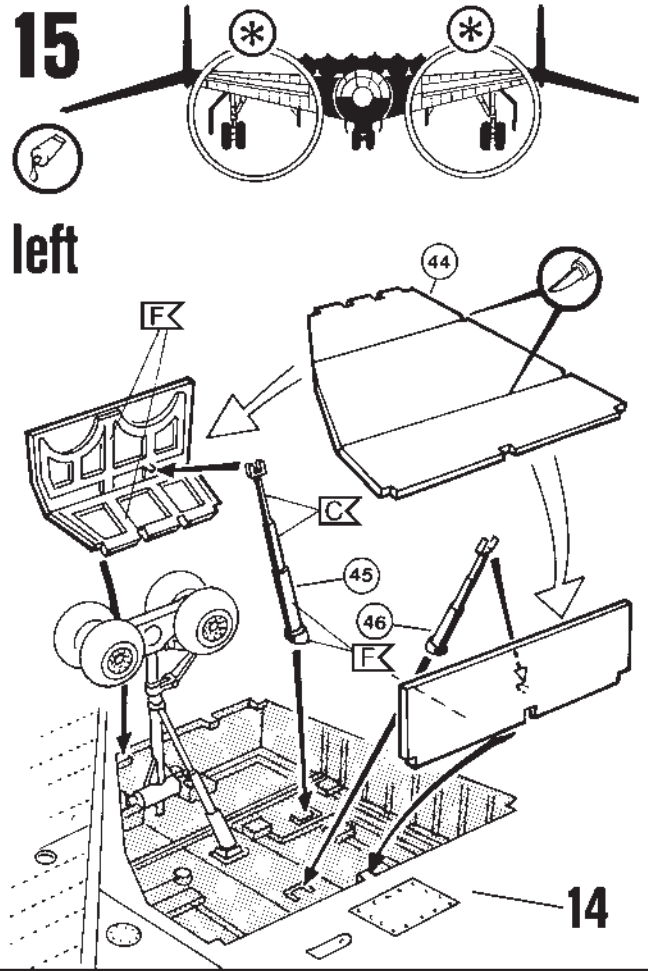

16



right

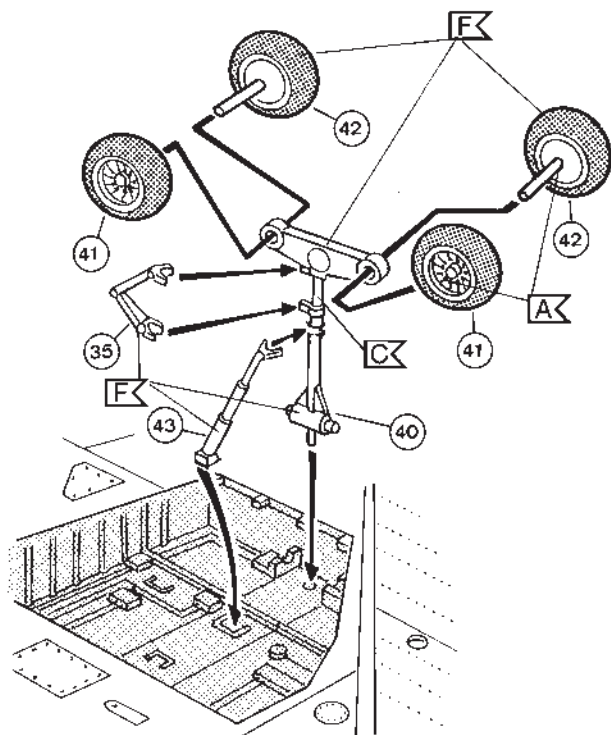

17



right

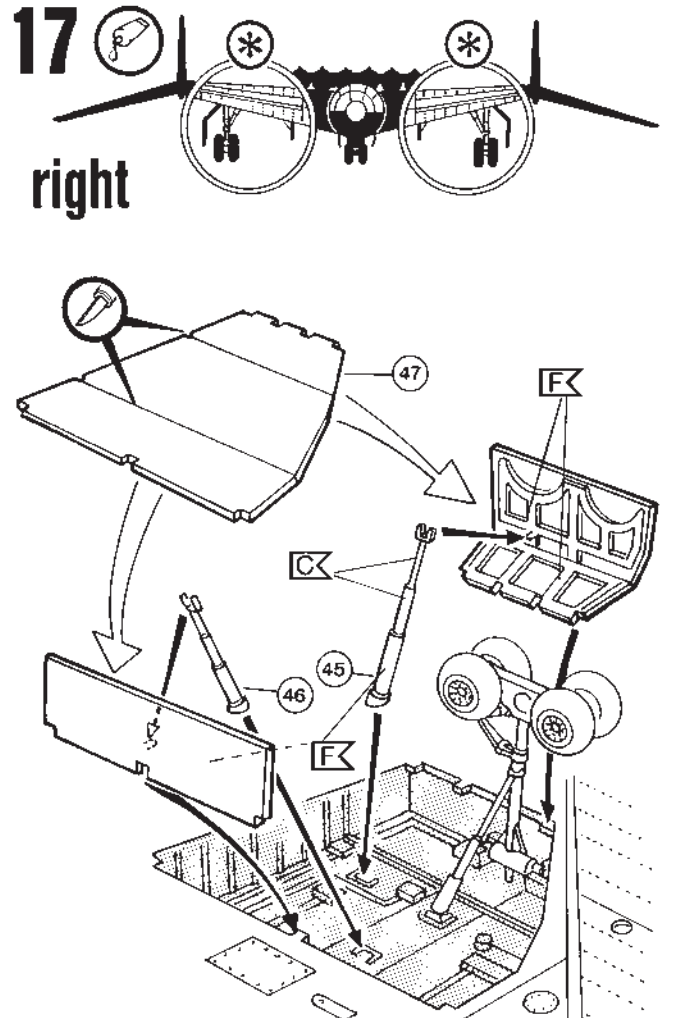

18  

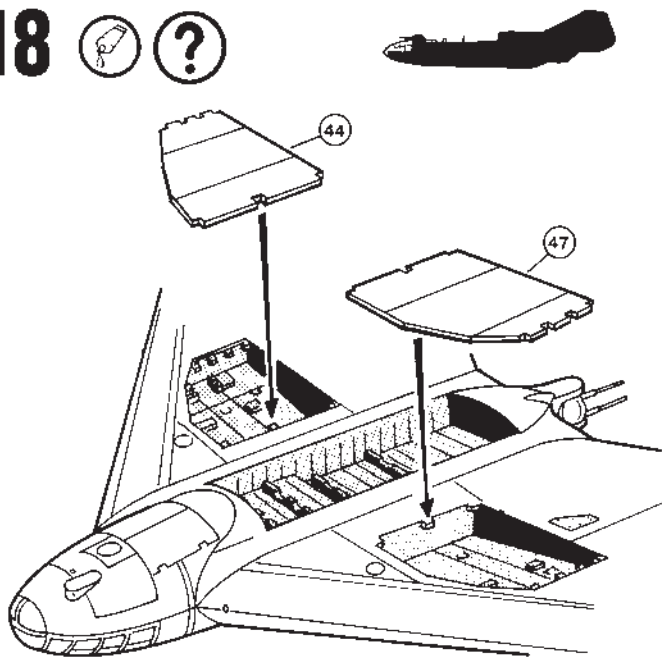

19  

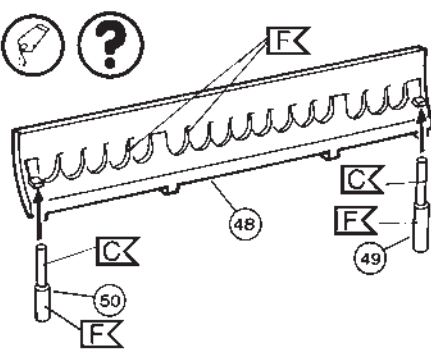

20

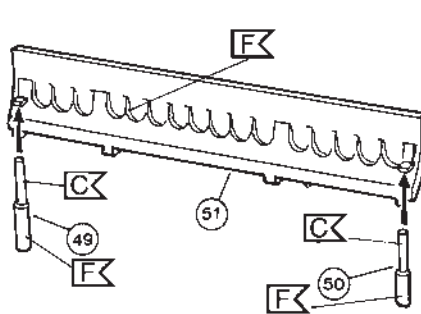

21  

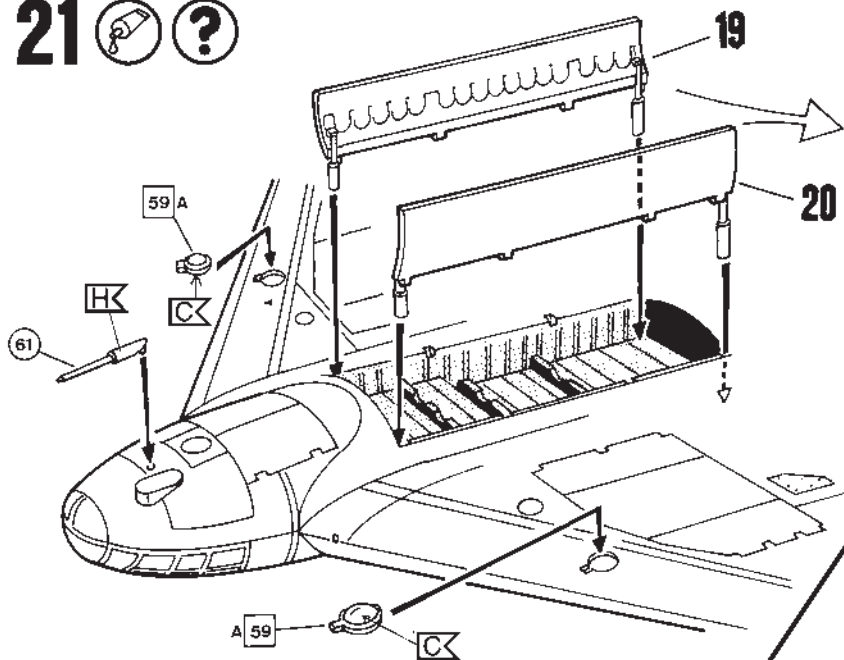

23



SC 1000 bomb

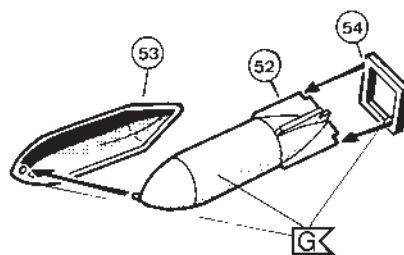

22  

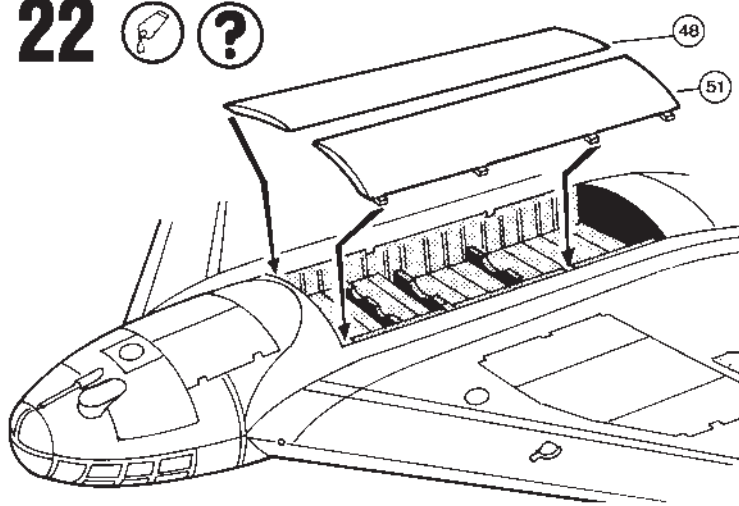

24



SC 2000 bomb

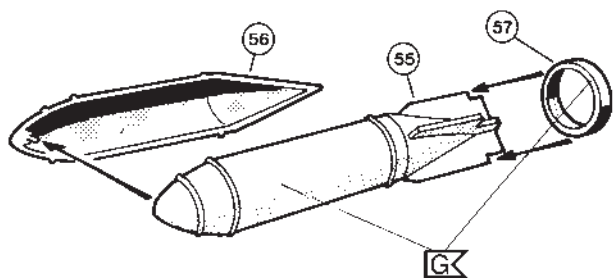

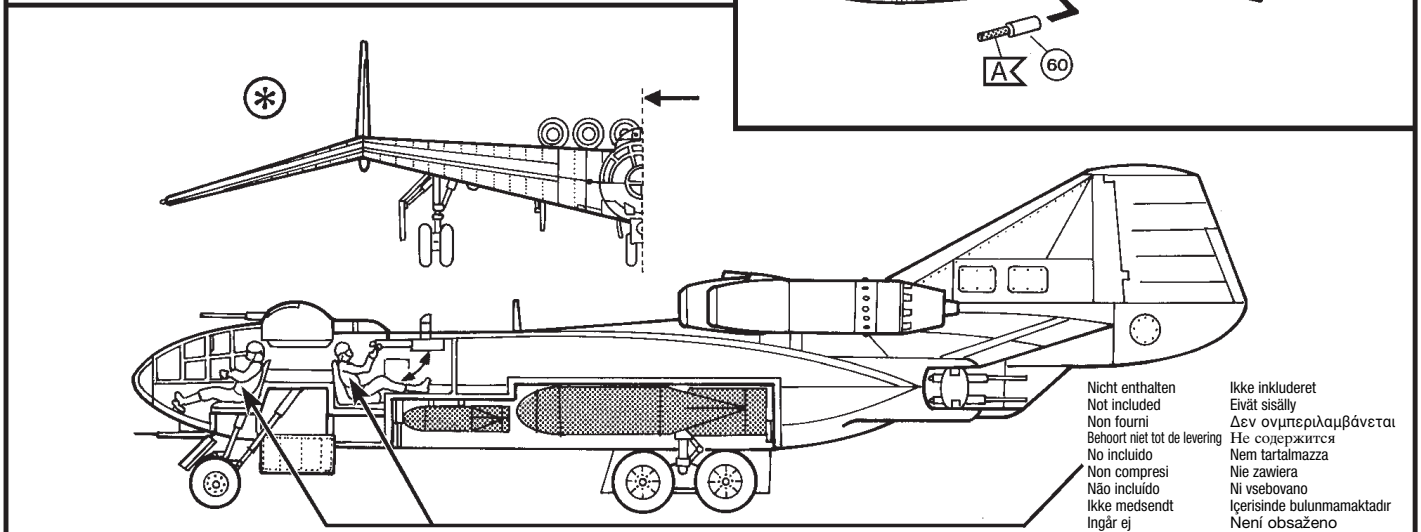
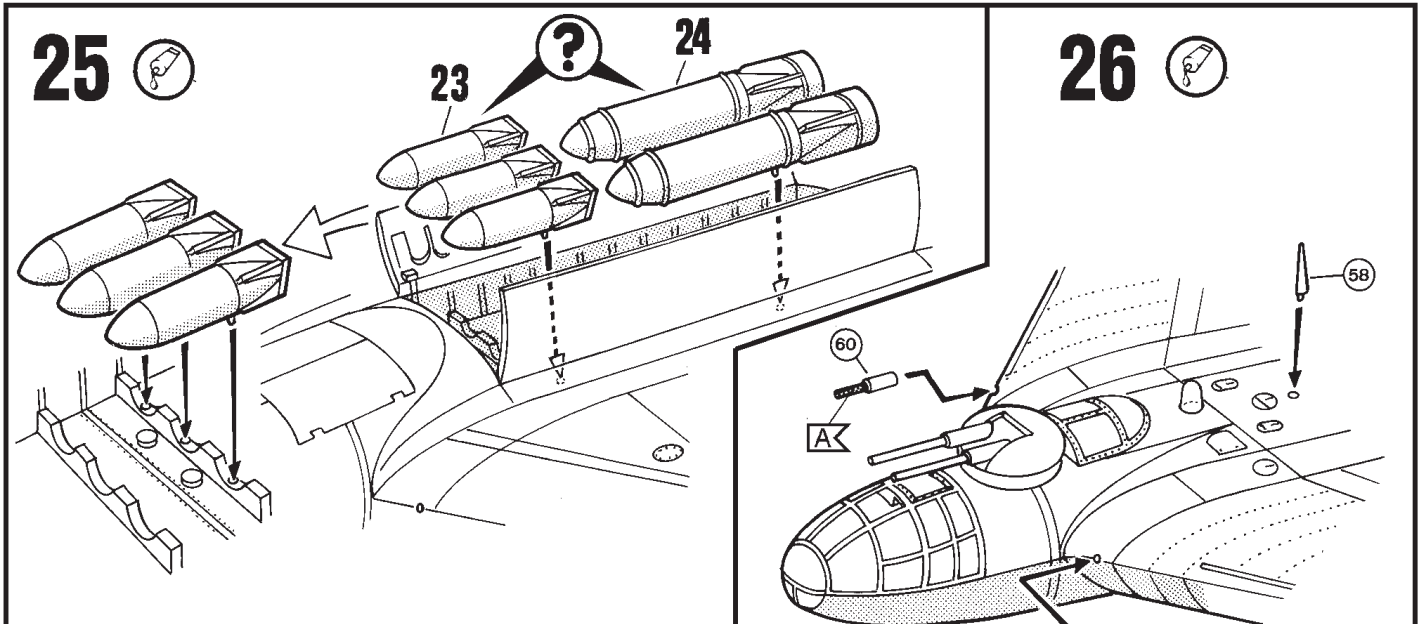

Nicht enthalten
 Not included
 Non fourni
 Behoort niet tot de levering
 No incluido
 Non compresi
 Não incluido
 Ikke medsendt
 Ingår ej

Ikke inkluderet
 Eivät sisälly
 Δεν συμπεριλαμβάνεται
 Не содержится
 Nem tartalmazza
 Nie zawiera
 Ni vsebovano
 İçerisinde bulunmamaktadır
 Není obsaženo

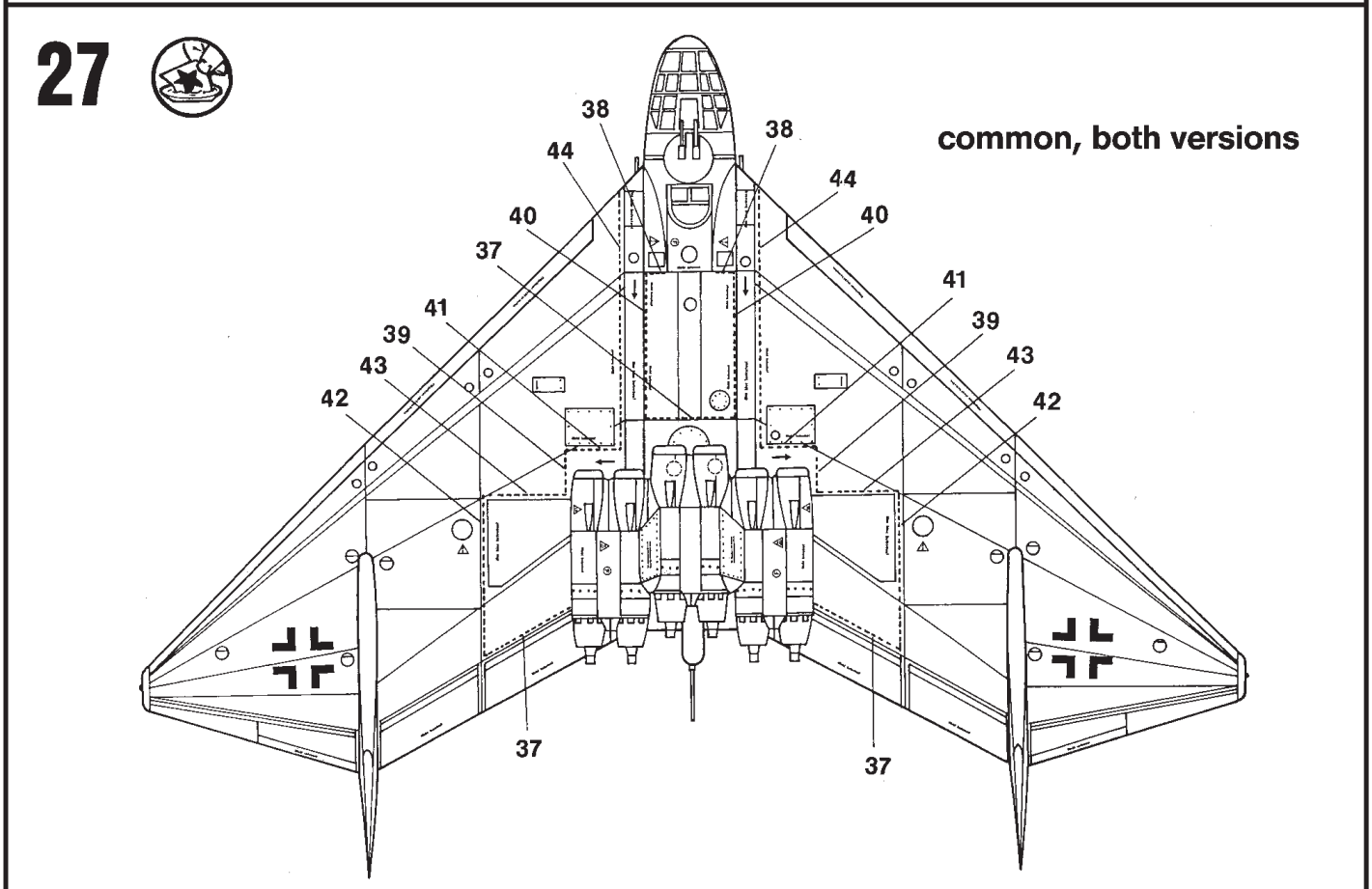

28



Arado Ar (E) 555 I/KG 100 Luftwaffe 1948 project

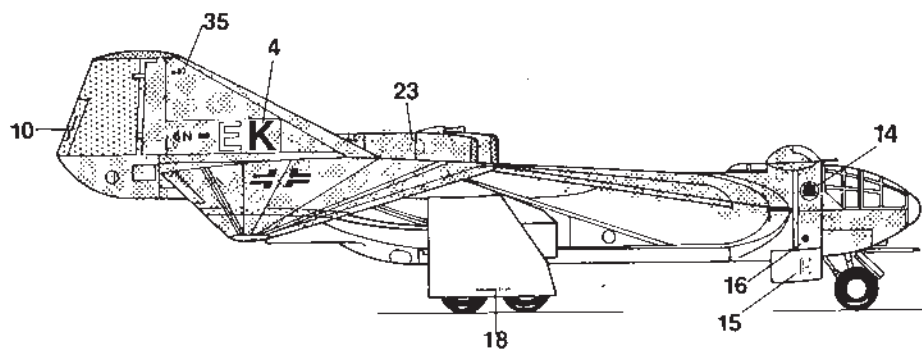
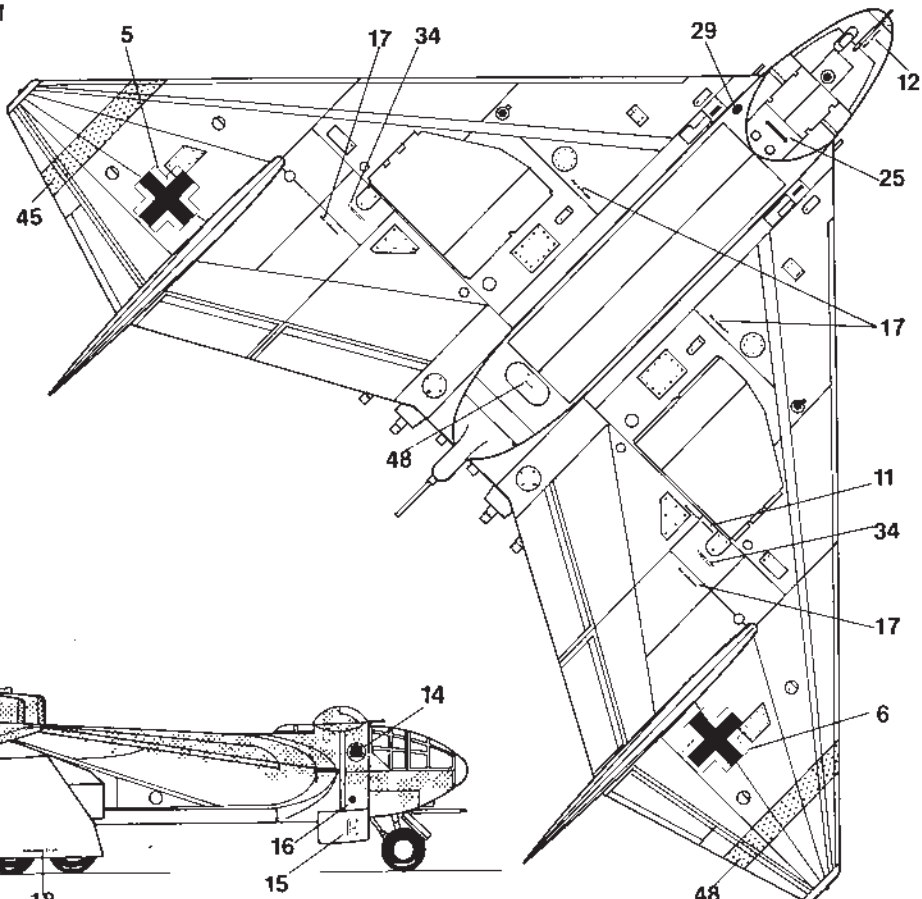
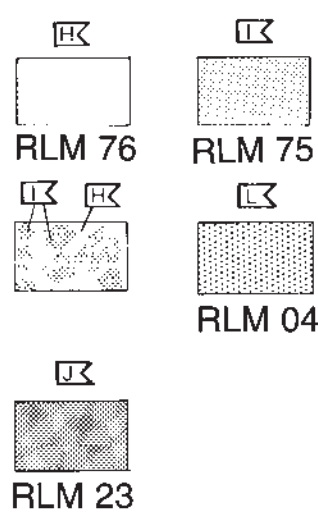
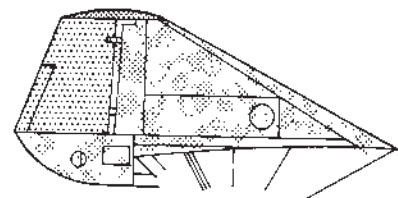
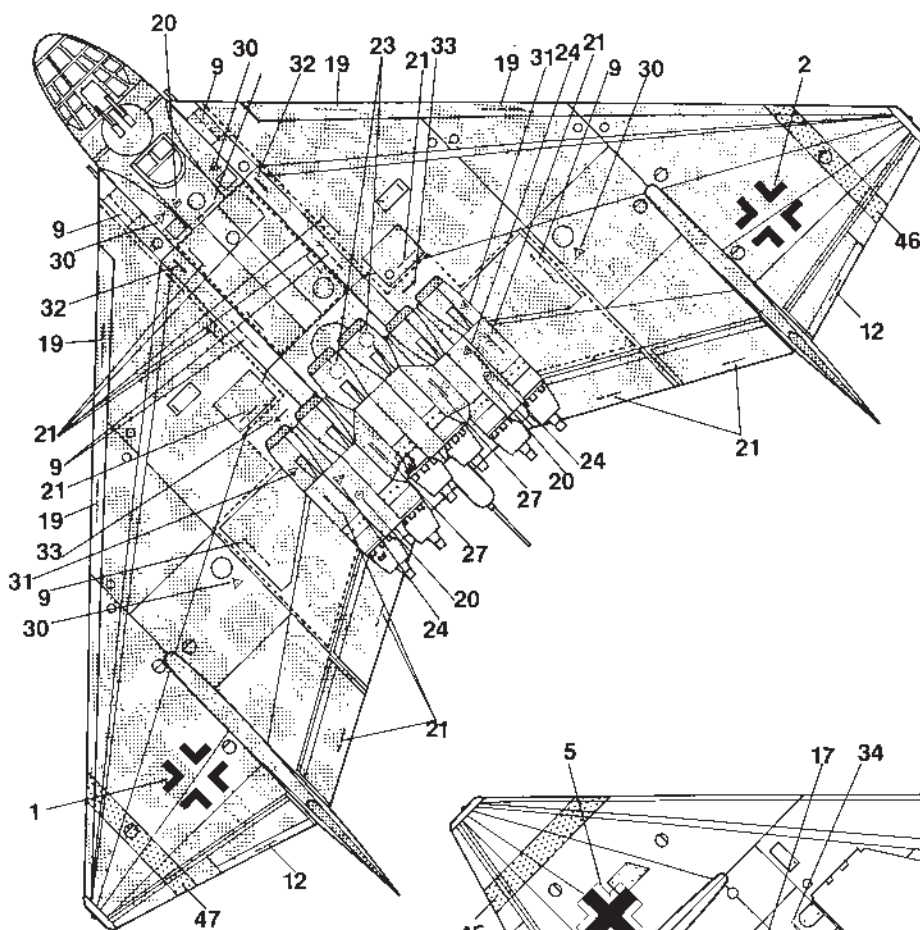
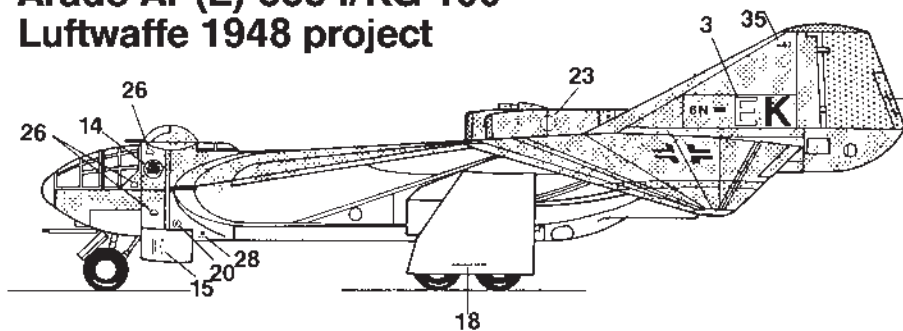

29

Luftwaffe, 1948 project wing/KG 200

