

# DBS

Digital Bypass Solid State Starter

INLINE / JAN 08 / REV 8  
SUPERSEDES JULY 07 / REV 7

---

## Operator's Guide and Instruction Manual



**RAM**

**INDUSTRIES**

**LLC**

# Table of Contents

<b>Starter Ratings .....</b>	<b>A</b>	<b>5.0 Set-Up Instructions .....</b>	<b>13</b>
<b>Dimensional &amp; Weight Data .....</b>	<b>B</b>	5.1 Inspection .....	13
<b>1.0 Description .....</b>	<b>1</b>	5.2 Set-up .....	13
1.1 Overview .....	1	5.3 System Configuration .....	13
1.2 Standard Features .....	1	5.4 Motor FLA .....	13
1.3 System Configuration Setup Parameters .....	2	5.4 DBS Control Board Setup .....	14
1.4 Control Modes .....	2	5.4 FLA Starter Size Table .....	15
1.5 Operating States .....	3	5.5 Prestart Adjustments - Constant Current .....	16
1.6 LED Diagnostics .....	3	5.6 Prestart Adjustment - Step Ramp .....	16
1.7.0 Electronic Motor Overload Protection and Monitoring .....	4	5.7 Current Step Switch - SW2 .....	17
1.7.1 Trip Conditions .....	5	5.8 Ramp / Bypass Time Switch - SW3 .....	17
1.7.2 Alarm Conditions .....	5	5.9 Reset Pushbutton - SW5 .....	17
<b>2.0 Specifications .....</b>	<b>6</b>	<b>6.0 Start-up Instructions .....</b>	<b>18</b>
2.1 Electrical .....	7	6.1 Start-up .....	18
2.2 Power Supply Required .....	7	6.2 Power-up .....	18
2.3 Control Power Required .....	7	6.3 Starting .....	19
2.4 Operator Devices .....	7	6.4 Re-adjustment .....	19
2.5 Output Contacts .....	7	<b>7.0 Troubleshooting .....</b>	<b>20</b>
<b>3.0 Receiving &amp; Installation .....</b>	<b>8</b>	7.1 Diagnostics & Troubleshooting .....	20-23
3.1 Receiving .....	8	<b>8.0 DBS Display Unit .....</b>	<b>24</b>
3.2 Mounting & Cleaning .....	8	8.1 Description .....	24
3.3 Installation .....	8	8.2 Operation .....	24
3.4 Derating Factor .....	8	8.3 Acknowledging Trips and Alarms .....	25
<b>4.0 Power &amp; Control Wiring .....</b>	<b>9</b>	8.4 Editing Set Points .....	26
4.1 Power & Motor Connection Diagrams .....	10	8.5 Confirming System Setup Options .....	26
4.2 Grounding .....	11	<b>9.0 Display Unit Menus .....</b>	<b>27-28</b>
4.3 Control Wiring .....	11	<b>10.0 RAM DBS Log .....</b>	<b>29</b>
4.4 External Connections .....	12	<b>11.0 Maintenance .....</b>	<b>30-32</b>
		<b>12.0 Replacement Parts .....</b>	<b>33-35</b>
		Appendix A Starter Size Dipswitch Positions .....	i
		Appendix B Typical Motor Connections .....	ii
		Appendix C SCR Test Procedures .....	ii
		DBS Glossary .....	iv

# List of Tables

TABLE 1	HP Ratings .....	A
TABLE 2	RMS Short Circuit Capacity Ratings .....	A
TABLE 3	Weight Data .....	B
TABLE 4	LED & Relay Status for Alarm & Trip Conditions .....	5
TABLE 5	DBS Specifications .....	6
TABLE 6	RMS Short Circuit Capacity Ratings .....	6
TABLE 7	DBS Control Transformer Sizing .....	7
TABLE 8	Lug Torque .....	9
TABLE 9	FLA Starter Size Tables .....	15
TABLE 10	Start-up Problems .....	20-23
TABLE 11	Monitor Menu .....	27
TABLE 12	Set Point Menu .....	27
TABLE 13	Fault History .....	28
TABLE 14	System Setup Menu .....	28

# List of Figures

FIGURE 1	DBS Dimensions .....	B
FIGURE 2	Power Factor Capacitor Connection .....	9
FIGURE 3	3 Lead Inline Connection - Forward Rotation .....	10
FIGURE 4	3 Lead Inline Connection - Reverse Rotation .....	10
FIGURE 5	External Connections to Boards .....	12
FIGURE 6	DBS Control Board .....	14
FIGURE 7	Prestart Adjustments - Constant Current .....	16
FIGURE 8	Prestart Adjustments - Step Ramp .....	16
FIGURE 9	Starter Size Dipswitch Positions .....	i
FIGURE 10	Typical Motor Connections .....	ii

# RAM DBS

## Solid State Starter

TABLE 1 **H.P. Ratings**

<b>208 V</b>	<b>230 V</b>	<b>460 V</b>	<b>575 V</b>	<b>DBS CHASSIS SIZE</b>
30	40	75	100	B1
50	50	100	150	B2
60	60	125	150	B3
60	75	150	200	C1
75	100	200	250	C2
100	125	250	300	C3
125	150	300	400	D1
150	200	400	500	D2
200	250	500	600	D3
250	300	600	800	E1
300	350	700	900	E3

TABLE 2 **UL Circuit Capacity Ratings  
of DBS Starters per UL 508 Standard**

<b>STARTER SIZES</b>	<b>WITH MAIN CIRCUIT BREAKER @ 480 VOLTS</b>	<b>WITH MAIN CIRCUIT BREAKER @ 600 VOLTS</b>	<b>WITH MAIN FUSED DISCONNECT @ 600 VOLTS</b>
B	65KA @ 480 VOLTS	18 KA @ 600 VOLTS	100 KA @ 600 VOLTS
C	65 KA @ 480 VOLTS	30 KA @ 600 VOLTS	100 KA @ 600 VOLTS
D	65 KA @ 480 VOLTS	42 KA @ 600 VOLTS	100 KA @ 600 VOLTS
E	65 KA @ 480 VOLTS	42 KA @ 600 VOLTS	100 KA @ 600 VOLTS

# RAM DBS

---

## Solid State Starter

**FIGURE 1 DBS Dimensions  
Open Chassis**

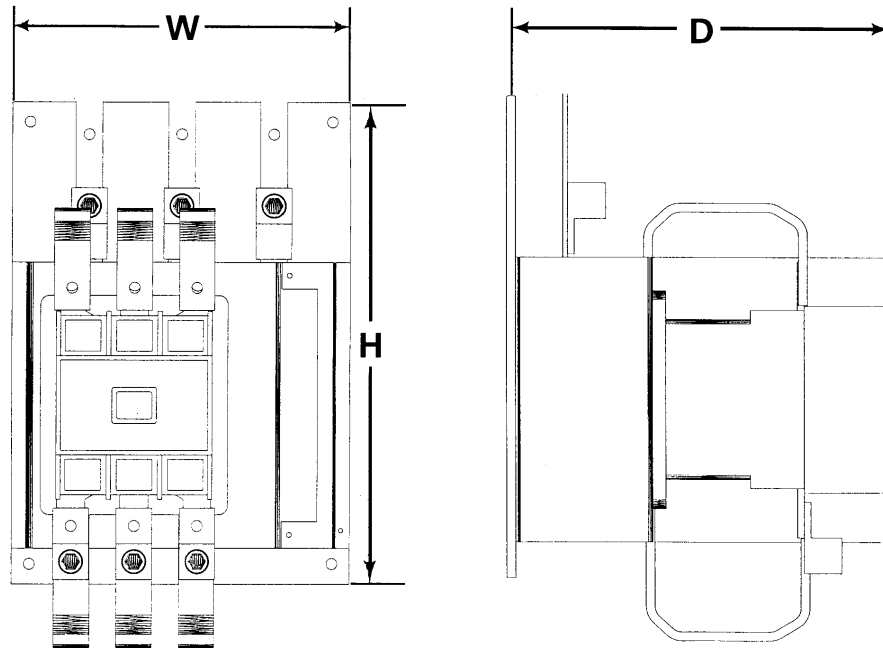

**TABLE 3 DBS Dimensional and Weight Data**

DBS CHASSIS SIZE	DIMENSIONS IN INCHES			WEIGHT LBS EACH
	W	H	D	
B	9.50	13.50	11.13	29
C	11.50	16.50	12.77	44
D	13.88	23.75	12.99	110
E	13.88	23.75	14.01	125

# RAM DBS

---

## Solid State Starter

### 1.0 Description

#### 1.1 Overview

The RAM DBS digital bypass solid state reduced voltage starter is a microprocessor controlled motor starting device which utilizes six SCRs (silicon controlled rectifiers) to electronically control the current supplied to an AC induction motor. The DBS accelerates the motor in a smooth stepless motion, therefore it reduces supply voltage dip during motor start and mechanical shock on the driven equipment. The unit automatically adjusts to any input voltage between 200 and 600 volts and to any frequency between 45 and 65 hertz.

The RAM DBS can be programmed to provide a gradual build up of torque from zero to almost full motor locked rotor torque. This method provides a gentle, jolt-free method of starting any AC induction motor. In addition, the starter can be programmed to limit starting currents to a constant value, thereby preventing excessive voltage drops during motor starting.

#### 1.2 Standard Features

**Universal Source Matching:** The RAM DBS automatically adjusts itself to any input voltage between 200 and 600 volts and any frequency from 45 to 65 Hz.

**Closed Loop Starting:** The RAM DBS starts a motor in a continuous controlled current mode, eliminating any motor jolt that could be experienced in other forms of reduced voltage starting.

**Automatic Bypass:** The RAM DBS includes a horsepower rated bypass contactor that is automatically engaged after the motor has reached full speed or when the bypass delay has expired. This reduces power losses and heat build up in the enclosure and allows the starter to be operated continuously, fully loaded, in an unventilated enclosure, surrounded by 40°C ambient air without overheating. The bypass contactor can also serve as an emergency starting device.

**Electronic Motor Overload Protection:** The RAM DBS has built-in Electronic Motor Protection. This microprocessor-based feature provides excellent motor overload protection and monitors and displays numerous system alarm and shutdown conditions. See Section 1.7 for full explanation of Motor Overload Protection features.

**LED Diagnostics:** The RAM DBS has four LEDs provided on the front of the unit to indicate the state of the DBS. Each LED is independently controlled by software. These LEDs are a valuable troubleshooting resource.

**Motor Connection:** No special motor is required. This unit can be connected to any standard 3 lead motor. See Section 4, Figure 3 and Figure 4 for typical 3 lead connection diagram.

**Dual Starting Modes:** Two starting modes provide optimum performance to match the RAM DBS to the motor load characteristics:

- a. Constant Current Mode: In this mode, the current during starting is maintained at a constant level, field adjustable from 200 to 425% of FLA. At full speed, the current is determined by the motor load.
- b. Step Ramp (Current Ramp) Mode: In this mode, the starting current quickly reaches the constant current level and then ramps up to 500% FLA. The ramp time is adjustable from 3-30 seconds. At full speed, the current is determined by the motor load.

# RAM DBS

## Solid State Starter

### 1.2 Standard Features (continued)

**Three Control Modes:** A choice of three different control operating modes are available: local control mode, display control mode, and network control mode. See Section 1.4 for a full explanation of each control mode.

**UL and CUL approved:** All models have undergone testing and are approved by Underwriters Laboratory per UL 508 Standard, and conform to Canadian National standards.

### 1.3 System Configuration Setup Parameters

The following system configuration setup parameters can be set only from switches on the control circuit board mounted inside the DBS controller.

- Full Load Amps (FLA)
- Current Step (% FLA)
- Ramp Time (Secs)
- Control Mode (Local, Display, Network)
- Network Address
- Overload Protection - Enabled / Disabled
- Constant Current / Step Ramp
- Inline Configuration

The above System Configurations can be changed only when motor is not running. Refer to Section 5, Figure 6, for switch configurations.

### 1.4 Control Modes

The RAM DBS can be set up to operate in three different control modes: Local Control, Display Control, and Network Control Mode. The control mode is selected by dip switches #1 & #2 of SW4, located on the front of the DBS. Refer to Section 5, Figure 6, for switch configurations.

Local Control Mode: Configuration is set by switches on the front of the DBS. No monitoring or diagnostic information is available in this mode. In addition, only a subset of trips are detected.

Trips detected:

- Thermal Overload, Shorted SCR, Phase Loss, Phase Reversal, Heatsink Overtemperature, and Short Circuit trips are supported in this mode.

Alarms detected:

- None in this mode.

Display Control Mode: The display module connects to the DBS via an RS-232 port. The display unit is mounted on the front of the enclosure door and permits access by service personnel to all monitoring and diagnostic information without opening the enclosure door. All aspects of motor operation and control are supported in this mode.

Trips detected:

- Thermal Overload, Shorted SCR, Phase Loss, Phase Reversal, Jam, Heatsink Overtemperature, and Short Circuit trips are supported in this mode.

Alarms detected:

- Current Unbalance alarm is supported in this mode.

# RAM DBS

## Solid State Starter

### 1.4 Control Modes (continued)

**Network Control Mode:** Configuration in this mode is set by the user's external control system computer, which is connected to the DBS via the Network RS485 port. Monitoring and diagnostic information is also available. Full fault detection is enabled in this mode.

Trips detected:

- Thermal Overload, Shorted SCR, Phase Loss, Phase Reversal, Jam, Heatsink Overtemperature, and Short Circuit trips are supported in this mode.

Alarms detected:

- Current Unbalance alarm is supported in this mode.

Refer to Section 5, Figure 6, for dip switch configurations.

### 1.5 Operating States

The RAM DBS has five operating states: Ready, Start, Run, Trip, and Cooldown. These states describe the DBS condition as seen by the microprocessor.

1. **READY** - The DBS is ready to start the motor. The DBS has passed all the preliminary system checks, including verifying there are no shorted SCRs, all internal system tests have passed, no phase reversals exist, and no trip conditions are present.
2. **START** - The DBS is in the process of starting the motor. Full speed has not yet been attained, and the bypass contactor has not yet been turned on.
3. **RUN** - The motor has reached full speed or the end of the bypass time has been reached. The bypass contactor has been turned on.
4. **TRIP** - The DBS has detected a trip condition and stopped the motor. If connected, the display unit will show the cause of the trip.
5. **COOLDOWN** - The motor has exceeded its thermal capacity and will not be allowed to start until enough time has elapsed to allow the motor to cool. The time before another start will be allowed can be viewed in the Monitor Menu under Time Till Start.

### 1.6 LED Diagnostics

The following LEDs are provided on the front of the main control unit located inside the starter and are useful when performing diagnostics with starter door open.

1. **READY** - LED is Green. Indicates the DBS is in the READY state.
2. **RUN** - LED is Green. Indicates the DBS is in the START or RUN state. The LED will blink when in the START state, then turn on steady once the RUN state is entered.
3. **ALARM** - LED is Yellow. Indicates the DBS has detected an ALARM condition. The LED will blink until the alarm is acknowledged by pressing the front panel RESET pushbutton or the ENTER key on the display unit. The cause of the alarm is then checked. If the condition is no longer present, the LED will go out, and normal operation can resume. If the condition is still present, the LED will turn on steady and remain on until the alarm condition is removed. If connected, the display unit will show the cause of the alarm.
4. **TRIP** - LED is Red. Indicates the DBS is in the TRIP state. The LED will blink until the trip is acknowledged by pressing the front panel RESET pushbutton or the ENTER key on the display unit. The cause of the trip is then checked. If the condition is no longer present, the LED will go out, and normal operation can resume. If the condition is still present, the LED will turn on steady and remain on until the trip condition is removed. If connected, the display unit will show the cause of the trip.



# RAM DBS

## Solid State Starter

### 1.7.0 Electronic Motor Overload Protection and Monitoring

The DBS features built-in microprocessor-based electronic motor monitoring and protection which accepts three-phase current and voltage signals. Based on these input signals and user presets, it generates a unique model of operating limits for the motor and records pertinent operating history. This information is valuable for troubleshooting and maintenance purposes.

Its ability to continuously monitor both voltage and current conditions seen by the motor enables it to calculate and monitor the thermal capacity of the motor, during both start and run states.

A number of fault conditions can be detected and reported depending on the DBS operational mode. Fault conditions can be displayed through the use of the DBS Door Mounted Display unit or by a host computer when the Network Control mode is utilized. Fault acknowledgment can be made from the DBS base unit, the door mounted Display Unit, or by a remote Network control location.

The DBS electronic microprocessor affords excellent motor overload protection against:

- Stall Condition
- Motor Overheating Beyond Its Thermal Capacity
- Locked Rotor Condition

Additional protection is supplied against:

- Jam
- Short Circuit
- Phase Loss
- Current Unbalance
- Phase Reversal

### 1.7.1 Trip Conditions

A trip condition will not allow a start or will stop the motor if it is running. The alarm LED and alarm relay will be activated and the trip condition will appear on the display.

**SHORT CIRCUIT** - This trip will occur if the current exceeds 800% FLA when the unit is in the START state. This condition will activate the **shunt trip**.

**SHORTED SCR** - This trip will occur if one or more of the SCRs is shorted. A trip will occur if line voltage / 1.73 is not present from line to load across each phase of the starter when the motor is properly connected. This voltage is checked only after a run signal is received. This trip will also occur if current flow is detected when the motor is not running. This current is an indication of a "runaway" motor and will result in the activation of the **shunt trip**.

**THERMAL OVERLOAD** - This trip will occur if the thermal energy stored in the motor exceeds 100% of motor thermal capacity. The estimated temperature of the motor windings is calculated based on the highest phase current. The overload trip level is computed based on the following setpoints: Full Load Amps, Locked Rotor Current, Stall Time, and Service Factor. A start will not be allowed until the motor has sufficiently cooled.

**PHASE REVERSAL** - This trip will occur if phase rotation on the incoming power is not: L1 - L2 - L3. A reversal condition is checked only after a run signal is received and can be corrected by swapping any two phases. Control power must be cycled to clear this fault.

(continued)

# RAM DBS

## Solid State Starter

### 1.7.1 Trip Conditions (continued)

**PHASE LOSS** - This trip will occur if one or more of the incoming voltage phases is lost when the motor is not running. This voltage is checked only after a run signal is received. This trip will also occur if one or more of the current feedback signals on TB2 of the power board is lost when the motor is running.

**HEATSINK OVERTEMPERATURE** - This trip will occur when the DBS heatsink temperature has exceeded safe operating conditions. The heatsink thermostat connected to P2 on the power board will open at 85°C and close at 60°C.

**PLL FAILURE** - The trip will occur if the phase lock loop circuit on the control voltage is out of lock when the unit is in the START state. Indicates poor power quality.

**JAM** - This trip will occur only in the RUN state if the current is above the Jam Current Level and the Jam Run Delay has expired.

### 1.7.2 Alarm Condition

An alarm condition can be detected and reported depending on the DBS control mode. The detection of an alarm condition will cause the DBS to light the Alarm LED. The alarm set points are adjustable when unit is operated in the Display or Network Control Mode. Refer to Set Point Menu, Section 9, Table 12, for alarm set points and defaults.

**CURRENT UNBALANCE** - This alarm will be activated when the Current Unbalance % exceeds the Current Unbalance level and the Current Unbalance Delay has expired.

$$\text{Current Unbalance \%} = \frac{\text{MAX Current Deviation from Average Current}}{\text{Average Current}} \times 100$$

TABLE 4 **LED and Relay Status for Alarm and Trip Conditions**

CONDITION	LEDs				RELAYS			
	READY	RUN	ALARM	FAULT	RUN	BYPASS	ALARM	SHUNT TRIP
<b>TRIP</b>								
SHORT CIRCUIT	~	~	~	ON	~	~	ON	ON
THERMAL OVERLOAD	~	~	~	ON	~	~	ON	~
SHORTED SCR	~	~	~	ON	~	~	ON	ON
PHASE REVERSAL	~	~	~	ON	~	~	ON	~
PHASE LOSS	~	~	~	ON	~	~	ON	~
JAM PROTECTION *	~	~	~	ON	~	~	ON	~
HEATSINK OVERTEMPERATURE								
PLL FAILURE								
<b>ALARM</b>								
CURRENT UNBALANCE *	N/A	N/A	ON	~	N/A	N/A	ON	~

\* AVAILABLE IN DISPLAY AND NETWORK MODES ONLY.

~ = OFF

# RAM DBS

---

## Solid State Starter

### 2.0 Specifications

**TABLE 5 DBS SPECIFICATIONS**

AC POWER SUPPLY	200V TO 600V RMS		
HP RATINGS	300HP @ 208V; 350HP @ 230V; 700HP @ 460V; 900HP @ 575V		
CURRENT CAPACITY	69 AMPS - 900 AMPS		
CONTROL VOLTAGE	115 VAC, +/-15%	NOTE: 115V CONTROL POWER MUST BE DERIVED FROM THE 3 PHASE POWER SOURCE.	
LINE FREQUENCY	45 TO 65 HZ		
THERMAL OVERLOAD CAPACITY	300% FLA FOR 40 SECONDS 600% FLA FOR 10 SECONDS		
OPERATING TEMPERATURE	0 TO 40 DEGREES C		
STORAGE TEMPERATURE	-40 TO 65 DEGREES C		
STANDARD STARTING MODES	CONSTANT CURRENT - 200% TO 425% FLA STEP RAMP - 200% TO 425% FLA, RAMP UP TO 500% FLA MAX		
USER ACCESSIBLE RELAYS	RUN RELAY: (2) SPST NORMALLY OPEN CONTACTS - 10 AMPS @ 250 VOLT AC, INDUCTIVE RATING SHUNT TRIP RELAY: (1) SPST NORMALLY OPEN CONTACT - 10 AMPS @ 250 VOLT AC, INDUCTIVE RATING ALARM RELAY: (1) SPDT 1-NORMALLY OPEN, 1-NORMALLY CLOSED CONTACT - 10 AMPS @ 250 VOLT AC, INDUCTIVE RATING		
COMMUNICATION PORTS	DISPLAY PORT - RS232, 9600 BAUD NETWORK PORT - RS485, 19,200 BAUD		
MINIMUM ENCLOSURE SIZE	<u>CHASSIS</u>	<u>VOLUME (ft<sup>3</sup>)</u>	<u>DEPTH (in)</u>
	B	5.0	12
	C	7.5	12
	D	16.0	16
	E	16.0	16
	NOTE: DEPTH INDICATES UL MINIMUM CONSULT FACTORY FOR CHASSIS CLEARANCE REQUIREMENTS		

**TABLE 6 UL Short Circuit Capacity Ratings of RAM DBS Starters per UL 508 Standard**

STARTER SIZES	WITH MAIN CIRCUIT BREAKER @ 480 VOLTS	WITH MAIN CIRCUIT BREAKER @ 600 VOLTS	WITH MAIN FUSED DISCONNECT @ 600 VOLTS
B	65KA @ 480 VOLTS	18 KA @ 600 VOLTS	100 KA @ 600 VOLTS
C	65 KA @ 480 VOLTS	30 KA @ 600 VOLTS	100 KA @ 600 VOLTS
D	65 KA @ 480 VOLTS	42 KA @ 600 VOLTS	100 KA @ 600 VOLTS
E	65 KA @ 480 VOLTS	42 KA @ 600 VOLTS	100 KA @ 600 VOLTS

# RAM DBS

## Solid State Starter

### 2.1 Electrical

### 2.2 Power Supply Required: 3 Phase, 200 to 600V, 45 to 65Hz.

### 2.3 Control Power Required: Single Phase, 115V, 50/60HZ

**NOTE: 115 Control Power Must Be Derived From The 3 Phase Power Source**

**NOTE: 250mA Control Power Fuse Is Located Behind TB1 On The Power Board**

TABLE 7

## DBS Control Transformer Sizing

STARTER SIZE	MINIMUM CONTROL TRANSFORMER VA
B1	150
B2	150
B3	250
C1	250
C2	250
C3	250
D1	500
D2	500
D3	500
E1	750
E3	750

### 2.4 Operator Devices: (supplied by customer) The RAM DBS is provided with terminal blocks for field connection of start and run contacts from external customer supplied devices such as:

- Start/Stop pushbuttons for 3-wire control
- Run Contact or On-Off Selector Switch for 2-wire control
- Jog Pushbutton

See RAM Wiring Diagrams for details.

### 2.5 Output Contacts: The RAM DBS is complete with the following contacts:

- Run Contact: (2) SPST NORMALLY OPEN CONTACTS  
10 AMPS @ 250 VOLT AC, INDUCTIVE RATING
- Shunt Trip Contact: (1) SPST NORMALLY OPEN CONTACT  
10 AMPS @ 250 VOLT AC, INDUCTIVE RATING
- Alarm Trip Contact: (1) SPDT 1-NORMALLY OPEN, 1-NORMALLY CLOSED CONTACT  
10 AMPS @ 250 VOLT AC, INDUCTIVE RATING

See RAM Wiring Diagrams for details.

# RAM DBS

## Solid State Starter

### 3.0 Receiving and Installation

#### 3.1 Receiving

1. Immediately upon receipt of the product, unpack the unit and inspect it for any shipping damages. If any shipping damages are encountered, notify the freight carrier and file a claim within 15 days of receipt.
2. Verify that the ratings sticker on the unit matches the motor's HP, current, and voltage rating for your installation.
3. Open the starter door and check for loose mechanical connections and assemblies, and broken or loose wires which may have occurred during shipping and installation.

#### 3.2 Mounting and Cleaning

1. When mounting the unit, make sure there is sufficient clearance (12" minimum) around the DBS enclosure for cooling, wiring, and maintenance purposes. Also make sure that the unit is mounted to meet the latest requirement of the National Electrical Code and any other local code requirements for working space (NEC Code Articles 110-13 and 110-16). When drilling or punching holes in the enclosure, cover the electrical assembly to prevent metal filings from becoming lodged in the unit and causing short circuits or reducing electrical clearances.
2. After mounting and wiring is completed, thoroughly clean and vacuum the enclosure, and make sure that all filings, metal chips, and other materials are removed before start-up.

**WARNING! Remove all sources of power before cleaning unit.**

#### 3.3 Installation

The enclosure containing the RAM DBS may be installed and operated at nameplate rating in an area where the following conditions exist:

- Ambient Temperature does not exceed 40 degrees C (104 degrees F) with a 15 degree C rise inside the enclosure as maximum.
- Ambient Temperature is not less than 0 degrees C (32 degrees F).
- Altitude above sea level is 6000 ft. (2000 meters) or less.
- Ambient air is reasonably clean, dry, and free of flammable or combustible vapors, steam, or corrosive gases.

#### 3.4 Derating Factor

**WARNING! When a RAM DBS enclosure is mounted in an environment not in accordance with Paragraph 3.3 as described above, it must be derated as follows:**

- Derate starter size 1.5% per degree C above 40 degrees C Ambient Temperature or 0.75% per degrees F above 104 degrees F Ambient Temperature.
- Derate starter size 1% for every 100m above 2000m or every 300 ft. above 6000 ft. elevation.

# RAM DBS

## Solid State Starter

### 4.0 Power and Control Wiring

#### 4.1 Power

Connect properly sized power lines to the DBS input terminals marked L1, L2, & L3. Avoid routing cable connections near the main circuit board. Refer to the National Electrical Code for wire sizing and lug torque.

TABLE 8 **Recommended Lug Torque**

UNLESS OTHERWISE NOTED ON INDIVIDUAL DEVICE

WIRE SIZE	TORQUE - in/lb	
	SLOTTED HEAD SCREWS	HEX OR SOCKET HEAD SCREWS
#18 - #14 AWG	12	75
#12 - #8 AWG	25	75
#6 - #4 AWG	35	110
#3 - #1 AWG		150
1/0 - 2/0 AWG		180
3/0 - 4/0 AWG		250
250 - 400 MCM		325
500 - 750 MCM		375

FIGURE 2 **Power Factor Capacitor Connection**

**CAUTION:** Power factor correction capacitors, when utilized, must be connected to the line side of the starter and never to the load.

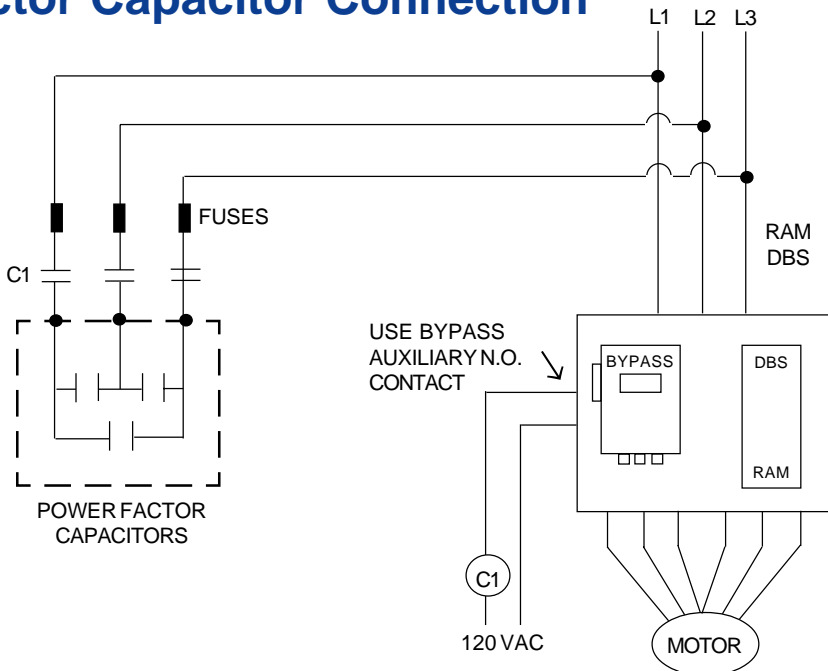

# RAM DBS

## Solid State Starter

### FIGURE 3 3 Lead Inline Connection - Forward Rotation

Connect properly sized motor leads to the starter as follows: Connect motor lead terminals T1, T2, and T3 to starter terminals A, B, and C, respectively.

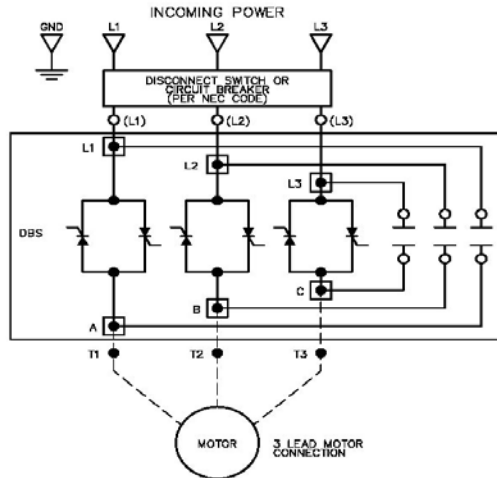

### FIGURE 4 3 Lead Inline Connection - Reverse Rotation

Connect properly sized motor leads to the starter as follows: Connect motor lead terminals T2, T1, and T3 to starter terminals A, B, and C, respectively.

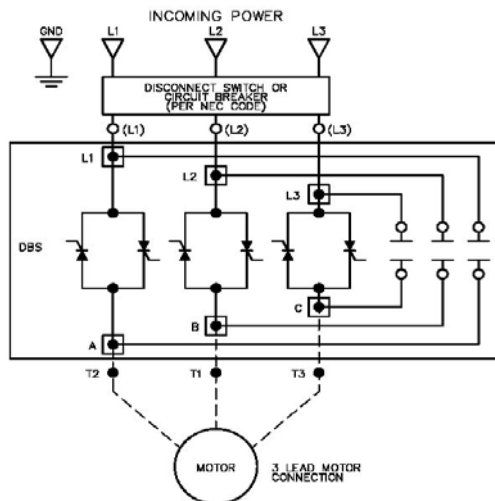

**NOTE:** The DBS cannot be tested without a motor or appropriate test load connected to the load side of the unit. In areas where frequent lightning occurs, lightning arrestors should be installed on the power source feeding the starter.

The RAM DBS is to be wired in accordance with the National Electrical Code and any other electrical codes applicable in customer's area.

**CAUTION!** Be sure to connect the power leads in the correct order: L1, L2, L3. The DBS is phase sensitive and will not operate if the phase sequence is incorrect. A Phase Reversal trip will occur if improperly connected.

# RAM DBS

## Solid State Starter

### 4.2 Grounding

Connect properly sized ground cable to the starter ground terminal. Refer to the National Electrical Code for proper size, and make sure the ground conductor is connected to a solid earth ground.

### 4.3 Control Wiring

Customer control wiring is to be connected to terminal block (TB1) of the DBS power board in accordance with RAM wiring diagrams supplied with job.

### 4.4 External Connections

There are 3 relays available for controlling external devices when not being utilized by the basic control starter circuit. Refer to Section 4, Figure 5, for availability of contacts. These contacts are connected to TB1 on the power board.

Run Relay - This relay turns on when a start sequence is initiated.

(2) SPST NORMALLY OPEN CONTACTS  
10 AMPS @ 250 VOLT AC, INDUCTIVE RATING

**Contacts 5 and 6 should be used ONLY as part of the start circuit.**

Contacts 7 and 8 may be used as a dry contact.

Shunt Trip Relay - This relay turns on when a fatal trip condition is detected.

(1) SPST NORMALLY OPEN CONTACT  
10 AMPS @ 250 VOLT AC, INDUCTIVE RATING

Alarm Relay - This relay turns on when an alarm condition exists.

(1) SPDT 1-NORMALLY OPEN, 1-NORMALLY CLOSED CONTACT  
10 AMPS @ 250 VOLT AC, INDUCTIVE RATING

### Communication Ports

Display Port - RJ-45 modular connector provides RS-232 communication for display. Refer to Sections 8 and 9 for display operation.

Network Port - 3 position terminal block provides RS-485 network communication. Receive (yellow) and Transmit (green) LEDs indicate network activity.  
JP1 (+) and JP3 (-) select 10k bias resistors: 1-2 Enable, 2-3 Disable.  
JP2 selects 120 ohm termination resistor: 1-2 Enable, 2-3 Disable.



# RAM DBS

## Solid State Starter

FIGURE 5 External Connections to Boards

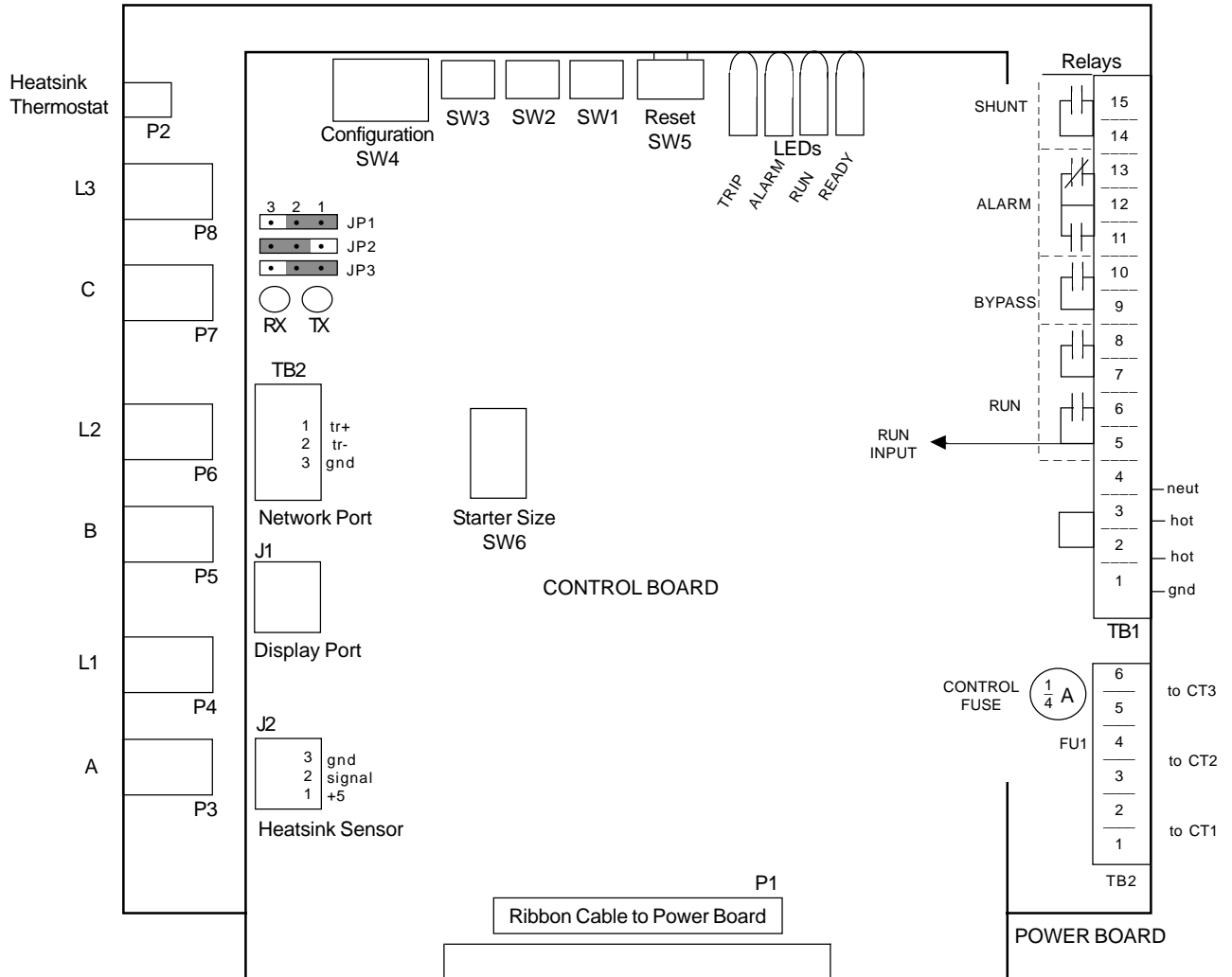

### Three-Wire Connection

Connect a maintained N.C. (normally closed) stop button between HOT (pin 2 or 3) and pin 6 of TB1 on the power circuit board. Connect a momentary N.O. (normally open) start button between HOT (pin 2 or 3) and pin 5 of TB1 on the power board.

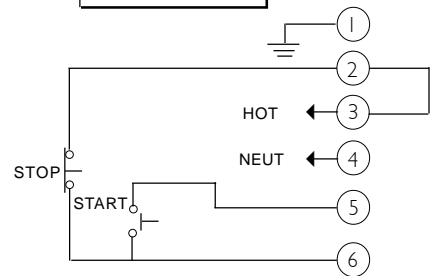

### Two-Wire Connection

An alternate connection for unattended operation replaces start/stop buttons by connecting a maintained N.O. contact closure (run switch or jog pushbutton) between pins 2 and 5 of TB1 on the power circuit board.

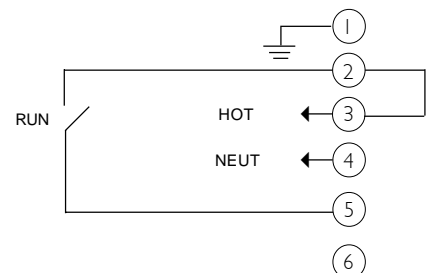

**CAUTION!** Two-wire connection must be opened (switched off) when a trip occurs in order to prevent the motor from restarting when the trip is cleared.

# RAM DBS

## Solid State Starter

### 5.0 Set-Up Instructions

**CAUTION! Equipment is at possibly lethal AC line voltage when AC power is connected. All phases must be disconnected by shutting down main power feed to this unit before it is safe to touch motor terminals or control equipment parts.**

#### 5.1 Inspection

Ensure that the starter has been installed according to the preceding guidelines. Ensure that the unit has been wired according to the schematics and all electrical codes. Check that all connections are tight. Check that motor shaft rotates freely.

**CAUTION! Before power is applied to the starter, the following settings and adjustments should be reviewed and appropriate changes made as required.**

#### 5.2 Set Up

This unit has been factory set for normal operation via the control board located on the DBS unit, see Figure 6. The DBS system configuration is set by dip switch SW4, the motor full-load current is set by switch SW1, Current Step is set by switch SW2, Ramp Time (when used) and Bypass Time is set by switch SW3.

#### 5.3 System Configuration Dip Switch - SW4

The DBS system configuration parameters are factory preset using an 8-position dip switch located on the main control board on the DBS unit, see Figure 6. These switches define the operation of Control Mode, Network Address, Overload Protection, and Step Ramp/Constant Current Mode. The system configuration parameters are factory set as defaults shown in Section 5, Figure 6. No changes are required in these switches in the normal operating mode.

#### 5.4 Motor FLA - SW1

Motor Full Load Current (Amps) has been factory set using Rotary Switch SW1 on main control board, see Section 5, Figure 6. This switch is set based on starter size, per Section 5, Table 9, to closest FLA rating of the motor.

**NOTE: Maximum Service Factor of 125% for FLA Switch #0-8, 115% for FLA Switch #9-B, 100% for FLA Switch #C-F.**

# RAM DBS

## Solid State Starter

FIGURE 6 DBS Control Board

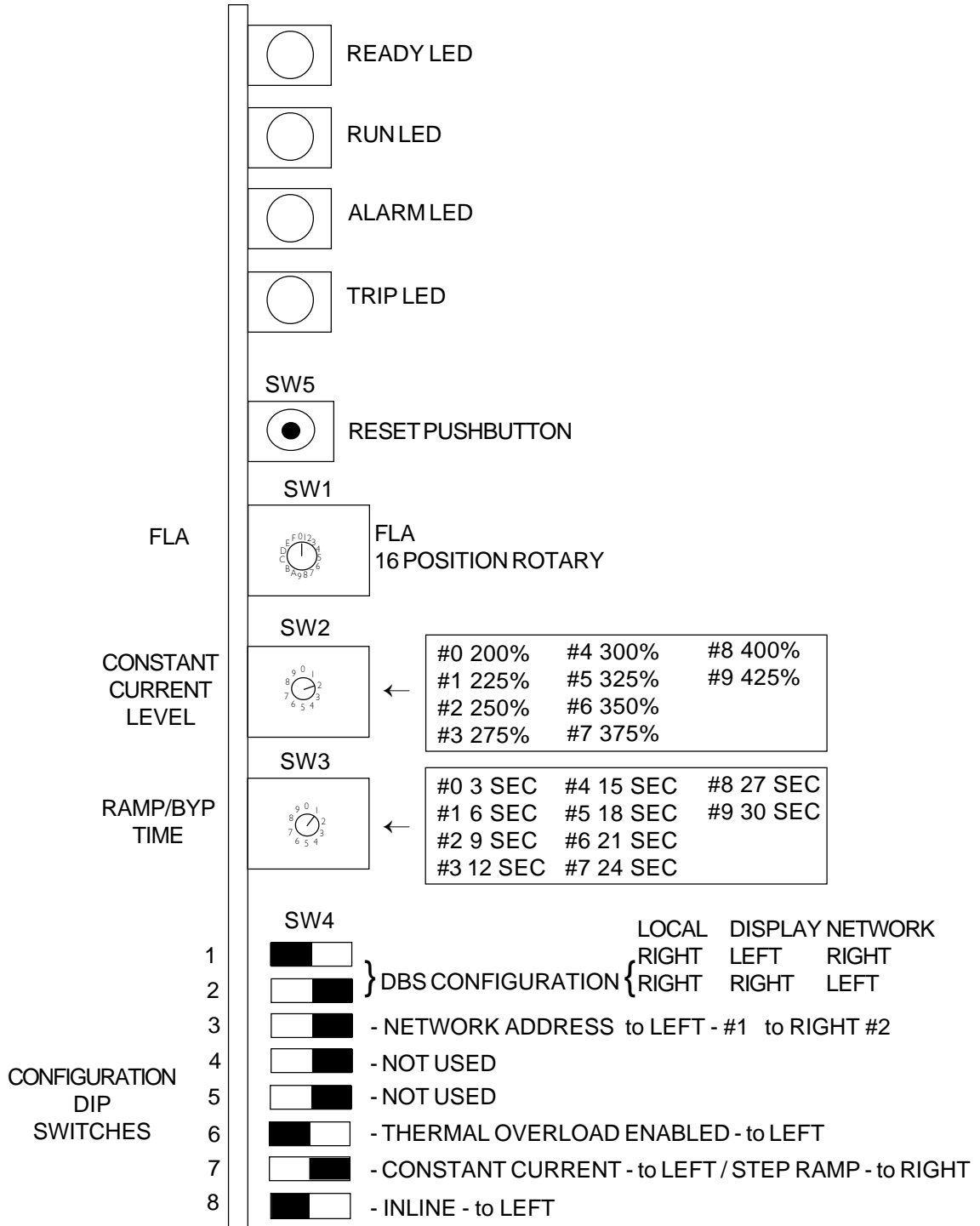

SWITCH IS TO LEFT SWITCH IS TO RIGHT

SWITCHES SHOWN IN FACTORY DEFAULT POSITIONS

# RAM DBS

## Solid State Starter

TABLE 9

### FLA - Starter Size Tables

Values shown are 100% FLA. Use value which most closely matches the motor nameplate current.

**NOTE: Maximum Service Factor of 125% for FLA Switch #0-8, 115% for FLA Switch #9-B, 100% for FLA Switch #C-F.**

STARTER B1	
SWITCH #	F.L.A.
0	69
1	71
2	73
3	76
4	78
5	81
6	83
7	86
8	89
9	91
A	94
B	97
C	100
D	104
E	107
F	110

STARTER C1	
SWITCH #	F.L.A.
0	131
1	135
2	139
3	144
4	148
5	153
6	158
7	163
8	168
9	174
A	179
B	185
C	191
D	197
E	203
F	210

STARTER D1	
SWITCH #	F.L.A.
0	250
1	258
2	266
3	275
4	283
5	292
6	302
7	311
8	321
9	331
A	342
B	353
C	364
D	376
E	388
F	400

STARTER E1	
SWITCH #	F.L.A.
0	485
1	500
2	516
3	533
4	550
5	567
6	585
7	604
8	623
9	643
A	663
B	684
C	706
D	729
E	752
F	776

STARTER B2	
SWITCH #	F.L.A.
0	94
1	97
2	100
3	103
4	107
5	110
6	113
7	117
8	121
9	125
A	129
B	133
C	137
D	141
E	146
F	150

STARTER C2	
SWITCH #	F.L.A.
0	169
1	174
2	180
3	186
4	192
5	198
6	204
7	210
8	217
9	224
A	231
B	238
C	246
D	254
E	262
F	270

STARTER D2	
SWITCH #	F.L.A.
0	313
1	323
2	333
3	344
4	355
5	366
6	378
7	390
8	402
9	415
A	428
B	442
C	456
D	470
E	485
F	500

STARTER E3	
SWITCH #	F.L.A.
0	563
1	581
2	599
3	618
4	638
5	658
6	679
7	701
8	723
9	746
A	770
B	794
C	820
D	846
E	873
F	900

STARTER B3	
SWITCH #	F.L.A.
0	110
1	113
2	117
3	121
4	125
5	129
6	133
7	137
8	141
9	146
A	150
B	155
C	160
D	165
E	171
F	176

STARTER C3	
SWITCH #	F.L.A.
0	203
1	209
2	216
3	223
4	230
5	237
6	245
7	253
8	261
9	269
A	278
B	286
C	296
D	305
E	315
F	325

STARTER D3	
SWITCH #	F.L.A.
0	375
1	387
2	399
3	412
4	425
5	439
6	452
7	467
8	482
9	497
A	513
B	529
C	546
D	563
E	581
F	600

# RAM DBS

---

## Solid State Starter

### 5.5 Prestart Adjustments - Constant Current

FIGURE 7 **Constant Current Mode**

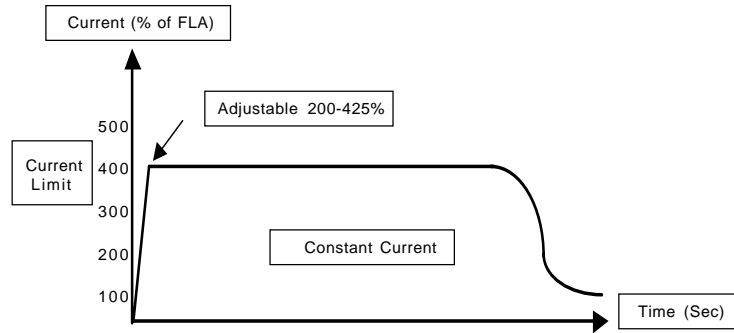

#### Constant Current

This method limits the starting current to a value adjustable from 200-425% FLA. The Constant Current mode is recommended for light and moderate inertial type loads. At rated horsepower, the Constant Current mode is capable of smoothly starting most loads without making any adjustments.

### 5.6 Prestart Adjustments - Step Ramp

FIGURE 8 **Step Ramp Mode**

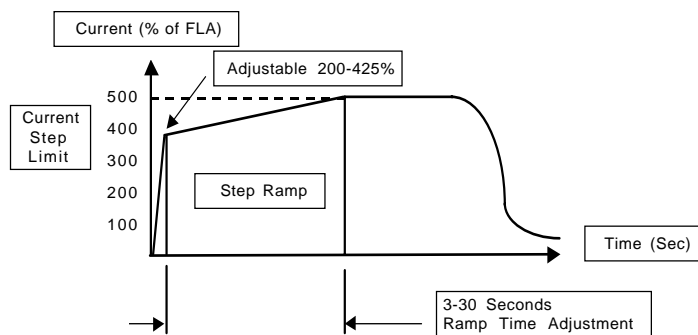

#### Step Ramp

On heavy inertia and friction type loads, an optional method of operating this starter at its rated horsepower can be accomplished by changing from Constant Current mode to Step Ramp mode. This operating mode limits the initial step current to a value adjustable from 200-425% FLA and then ramps the current to a maximum of 500% FLA.

# RAM DBS

---

## Solid State Starter

### 5.7 Current Step Switch - SW2

The 10-position switch (SW2), located on the main control board of the DBS, sets the initial current step of the controller in either Constant Current or Step Ramp mode. This switch is adjustable from 200-425% FLA for smooth acceleration. When the controller is set for Constant Current, this switch sets the maximum current limit for the motor in this mode of operation. This current is maintained until the motor reaches full speed. When the controller is set for Step Ramp, this switch sets the initial current limit, and then allows the controller to continue its ramp to 500% FLA.

### 5.8 Ramp / Bypass Time Switch - SW3

The 10-position switch (SW3), on the main control board of the DBS, is adjustable from 3-30 seconds and sets the time in seconds in which the current rises in the Step Ramp mode from its initial Current Step level described in Paragraph 5.7, to 500% FLA. When the controller is set for Constant Current, this switch sets the bypass time. The bypass time for Step Ramp mode is 5 seconds, plus Ramp time.

### 5.9 Reset Pushbutton - SW5

This pushbutton, located on the main control board, allows the operator to acknowledge a fault condition. The DBS control unit will not allow the motor to start until all trip conditions are cleared. A fault can be acknowledged in all three control modes.

The Alarm or Trip LED will blink as long as the alarm/trip condition remains (phase loss, reversal, etc.). The LED will turn off after the fault condition is eliminated and the reset button is pressed. The LED will remain On steady after the reset pushbutton is pressed if the fault has not been eliminated.

# RAM DBS

## Solid State Starter

### 6.0 Start-Up Instructions

**CAUTION! Equipment is at possibly lethal AC line voltage when AC power is connected. All Phases must be disconnected by shutting down main power feed to this unit before it is safe to touch motor terminals or control equipment parts.**

1. Verify that incoming supply voltage matches the rated supply voltage of the DBS unit.
2. Verify that full-load amps (FLA) of motor does not exceed the FLA rating of the DBS being used, as shown in Section 5, Table 9.
3. Follow the Setup Instructions in Section 5.2 and verify that the 8-position dip switch, located on the main control board, is set correctly for application. (See Factory Default Settings, Section 5, Figure 6)
4. Verify that the 16-position FLA switch (SW1) on the main control board is set in correct position for the starter size and FLA of motor being used. Starter size is shown on the chassis nameplate.
5. Verify that Current Step switch (SW2), located on the main control board, is set in accordance with the RAM data sheet for this job. This switch is adjustable from 200-425% of FLA.
6. When DBS is set to operate in Step Ramp mode, the Ramp Switch (SW3) should be set to control the time in seconds in which the current rises from its initial current setting to 500% FLA. This switch designates the bypass time when starter is in Constant Current mode.
7. Verify that properly sized power leads are connected to DBS incoming terminals L1, L2, and L3.
8. Verify that properly sized ground cable is connected to Ground Terminal on DBS.
9. Check motor lead connections and verify that proper power leads are connected to DBS as shown in Section 4, Figure 3 and Figure 4, depending on rotation of motor.
10. Verify that control wire connections are made per RAM wiring diagram.

#### 6.1 Start-Up

When starting the RAM DBS unit, it is recommended that a clamp-on AC Ammeter be used to continuously monitor the motor current during the start-up procedure. A Voltmeter placed across the starter output is also desirable.

#### 6.2 Power-Up

Once the prestart adjustments have been checked and correctly set up, it is ready for power up.

Check that all personnel and equipment are clear of the starter and motor, then apply power.

The green "READY" LED on the main control board will come on after the DBS has passed all of its preliminary system checks. These tests verify that there are no shorted SCRs, all internal system tests have passed, and that no phase reversals or other faults exist.

### 6.3 Starting

To start the unit, energize the “Start” circuit and the motor will begin to accelerate. The Green “RUN” LED will blink while in the Start state. When the motor reaches full speed, the Green “RUN” LED on the main control board will turn on steady. This indicates that motor has reached full speed and that the bypass Contactor is engaged. If the motor does not accelerate, confirm all adjustments and make sure the motor is started in an unloaded condition.

**CAUTION! Do not allow the motor to remain energized if it stalls. If the motor fails to accelerate, immediately de-energize the motor by local, remote, or manual stop control.**

If at anytime during the starting cycle, the motor should cease accelerating or stop, disconnect control power to the circuit and open the line disconnect.

For remotely located motor, it is essential to have another person stand by the motor to verify motor rotation during initial Startup.

With the clamp-on Ammeter, check that all three line currents are balanced.

If the motor still fails to start after making adjustments, consult the Troubleshooting Section, 7.0.

### 6.4 Re-Adjustments

After the motor has been started, fine adjustment might be required. It is a good practice to set the starter to reach full speed in the minimum time permissible without causing any appreciable power dip or excessive mechanical stress. The longest acceleration time is not necessarily the best setting.



# RAM DBS

## Solid State Starter

### 7.0 Troubleshooting

**CAUTION!** Equipment is at possibly lethal AC line voltage when AC power is connected. All Phases must be disconnected by shutting down main power feed to this unit before it is safe to touch motor terminals or control equipment parts.

#### 7.1 Diagnostics and Troubleshooting

The RAM DBS is provided with four LEDs for quick diagnostics. The LEDs are on the front of the main control board on the DBS chassis. Refer to LED Diagnostics, Section 1.6.

TABLE 10 **Start-Up Problems**

PROBLEM	PROBABLE CAUSE	SOLUTION
1. Motor will not start.	<ol style="list-style-type: none"><li>1. Start circuit wired incorrectly.</li><li>2. No start input signal.</li></ol>	<ol style="list-style-type: none"><li>1. Remove power; correct wiring.</li><li>2. Confirm voltage exists between terminals 4 and 5 on DBS control board.</li><li>3. Restore start input signal from micro controller.</li></ol>
2. Display and LEDs not illuminated.	<ol style="list-style-type: none"><li>1. No control voltage on DBS control board.</li></ol>	<ol style="list-style-type: none"><li>1. Check FU1 fuse on DBS control board.</li></ol>
3. Controller does not make transition to RUN.	<ol style="list-style-type: none"><li>1. Defective bypass contactor.</li><li>2. FLA setpoint (SW1) not programmed properly.</li><li>3. Motor incorrectly connected.</li></ol>	<ol style="list-style-type: none"><li>1. Check operation of contactor; connect remote source of control power to contactor.</li><li>2. Coordinate SW1 setting with FLA of motor. See Table 10.</li><li>3. Connect motor per motor nameplate.</li></ol>
4. Cannot enter EDIT mode to change setpoint values.	<ol style="list-style-type: none"><li>1. DBS controller is in "Start" or "Run" state.</li></ol>	<ol style="list-style-type: none"><li>1. Setpoint values cannot be changed while motor is running.</li><li>2. Status code "rdy", "trip", or "cool" must appear on display.</li></ol>

# RAM DBS

## Solid State Starter

TABLE 10 (continued) **7.1 Trip Conditions**

TRIP CONDITION	PROBABLE CAUSE	SOLUTION
1. Jam	<ol style="list-style-type: none"> <li>Current exceeded Jam Trip level set point longer than time delay set point while in RUN state.</li> </ol>	<ol style="list-style-type: none"> <li>Acknowledge trip.</li> <li>Confirm Jam trip and delay setpoints.</li> <li>Resolve mechanical problems of driven equipment.</li> </ol>
2. Short Circuit	<ol style="list-style-type: none"> <li>Current exceeded 800% of FLA set point while motor was starting.</li> </ol>	<ol style="list-style-type: none"> <li>Acknowledge trip.</li> <li>Confirm correct motor wiring.</li> <li>Check for shorts in starter and motor junction box: phase-to-phase, phase-to-ground.</li> </ol>
3. Thermal Overload	<ol style="list-style-type: none"> <li>Calculated thermal capacity of motor exceeded 100% of limit.</li> <li>Motor is "short-cycling".</li> </ol>	<ol style="list-style-type: none"> <li>Acknowledge trip.</li> <li>Allow motor to cool then re-start.</li> <li>Check current of fully loaded motor to verify whether it exceeded its temperature limit. Compare reading from clamp-on ammeter with readout on display unit to confirm accurate sensing by DBS.</li> <li>Confirm setpoints: <ul style="list-style-type: none"> <li>• FLA (SW1)</li> <li>• Locked rotor current</li> <li>• Stall time</li> <li>• Service factor</li> </ul> </li> </ol>
4. Shorted SCR (circuit breaker trips in READY state)	<ol style="list-style-type: none"> <li>Defective SCR.</li> <li>Defective bypass contactor.</li> <li>Motor disconnected.</li> <li>Inspect main contacts of bypass contactor.</li> </ol>	<ol style="list-style-type: none"> <li>Acknowledge trip.</li> <li>Reset circuit breaker due to shunt trip actuation.</li> <li>Check SCRs per test procedure. (See Appendix) Call RAM if defective. Do not replace in field.</li> <li>Inspect main contacts of bypass contactor.</li> </ol>

# RAM DBS

## Solid State Starter

TABLE 10 (continued) **7.1 Trip Conditions**

TRIP CONDITION	PROBABLE CAUSE	SOLUTION
5. Phase Loss	<ol style="list-style-type: none"> <li>1. Loss of at least one phase of supply voltage.</li> <li>2. Loss of at least one phase of current feedback.</li> </ol>	<ol style="list-style-type: none"> <li>1. Acknowledge trip.</li> <li>2. Restore power.</li> <li>3. Check CT connector TB2 on DBS control board.</li> <li>4. Check gate lead connections P3-P8 on DBS control board.</li> <li>5. Replace DBS control board.</li> </ol>
6. Phase Reversal Trip (Trip occurs in READY state)	<ol style="list-style-type: none"> <li>1. Incorrect phase order at DBS chassis input terminals.</li> <li>2. Control power applied before 3 phase power.</li> </ol>	<ol style="list-style-type: none"> <li>1. Acknowledge trip.</li> <li>2. Reverse L1 and L2 power wires at DBS chassis input.</li> <li>3. If control power is derived from separate source, it must be in phase with the power supply to DBS chassis.</li> </ol>
7. Heat Sink Overtemperature	<ol style="list-style-type: none"> <li>1. Temperature of heat sink has exceeded maximum safe operating temperature of 85 deg. C.</li> <li>2. Heat sink cable connection P2 is loose.</li> </ol>	<ol style="list-style-type: none"> <li>1. Acknowledge trip.</li> <li>2. Allow starter to cool, then re-start motor.</li> <li>3. Assure ambient temperature does not exceed 40 deg. C.</li> <li>4. Controller load capacity must be derated when ambient temperature exceeds 40 deg. C.</li> <li>5. Replace defective heat sink cable.</li> </ol>

# RAM DBS

## Solid State Starter

TABLE 10 (continued) **7.1 Alarm Conditions**

<b>ALARM CONDITION</b>	<b>PROBABLE CAUSE</b>	<b>SOLUTION</b>
1. Current Unbalance	<ol style="list-style-type: none"><li>1. Current between two phases exceeds the setpoint value longer than the time delay setpoint.</li><li>2. Voltage unbalance.</li><li>3. Abnormal SCR operation.</li></ol>	<ol style="list-style-type: none"><li>1. Acknowledge trip.</li><li>2. Check for voltage balance between phases. Customer must consult power supplier if balance is abnormal.</li><li>3. Load balance on customer's system must be re-distributed.</li><li>4. Current unbalance and current run delay setpoints may need adjustment. See Table 14, Section 9.</li></ol>

## 8.0 DBS Control Display Unit

### 8.1 Description

The DBS Display unit, when utilized, is mounted on the panel door so it can be accessed by service personnel without opening the door. All aspects of motor operation and control can be performed from here. The display unit connects to the DBS via an RS-232 port.

#### **DISPLAY UNIT**

The display unit consists of a 2 line by 20 character Liquid Crystal Display with backlight. The display shows the current menu selection, operating mode, associated value, and unit of measurement.

#### **MENU SCREENS**

The display unit has four menu selections: MONITOR MENU, SET POINT MENU, SYSTEM SET UP MENU, and FAULT HISTORY MENU. These menus enable the user to view and edit pertinent motor, operating, and historical data related to the controller.

#### **PUSHBUTTONS**

Four pushbutton keys labeled ENTER, SELECT, UP, and DOWN are utilized to move through the menu screens, edit set point values, and acknowledge alarm and trip conditions.

#### **ALARM**

An Alarm LED alerts the user to the presence of any alarm or trip condition. The Alarm LED will blink when a fault occurs. Once the fault is acknowledged, the LED will:

- 1) turn off if the fault condition no longer exists.
- 2) turn on steady until the fault condition is removed.

### 8.2 Operation

Upon initial power-up, the display screen on the Display Unit will read "RAM Industries." After internal system checks have been completed, "MONITOR MENU" will be displayed.

A Status Code is continually displayed in the lower left corner of the LCD screen. The Status code allows the user to view the operating state of the DBS at all times.

The codes are:

- run - DBS is in the RUN state
- rdy - DBS is in the READY state
- strt - DBS is in the START state
- trip - DBS is in the TRIP state
- cool - DBS is in the COOLDOWN state
- edit - DBS is in the EDIT mode

#### **Viewing and Editing Data**

The four keys found on the display unit are used to move through the menu selections, edit set point values, and acknowledge alarms or trips. When the display unit is powered up, the MONITOR MENU appears on the screen. If you press the SELECT key, you can scroll through three other menu screens: SET POINT MENU, FAULT HISTORY MENU, SYSTEM SET UP MENU, and finally back to the MONITOR MENU.

The unit must be in the Ready or Trip State without the motor running to allow changes in the Edit mode.

# RAM DBS

## Solid State Starter

### 8.2 Operation (continued)

#### Pushbutton Functions

**SELECT BUTTON** - The SELECT key is used to scroll through the four menu screens (Monitor, Set Point, Fault History, and System Setup). When you are in any parameter of a menu, pressing the SELECT key will return you to the title screen of that menu. When a value is being edited in any menu screen, pressing the SELECT key will abort the "Edit" and revert the value to the original setting.

**UP/DOWN BUTTONS** - When displaying the menu parameters, the Up and Down keys are used to view the contents of each menu screen. By pressing the UP or DOWN key, the user is permitted to scroll through the contents of each menu screen.

**ENTER BUTTON** - The Enter key has a dual function. When a fault occurs, the ENTER key, if pressed, will acknowledge trip and alarm conditions. When a set point is being edited in the SET POINT menu, the ENTER key must be pressed to enter the "Edit" mode. Once a new value is selected, the ENTER key must be pressed again to store the new value into the nonvolatile memory for permanent use by the protection device. While in the System Setup menu, the ENTER key is pressed to select certain options. The ENTER key has no effect if pressed while in any of the main menus or in the menu parameters of the MONITOR or FAULT HISTORY menus.

#### Normal Operating Mode

In normal operational mode, the control display unit should be set in the MONITOR MODE. In this mode, the user can acknowledge alarm or trip conditions, monitor the current operating status of the system, and view motor operating data in the display window.

To get to this menu from any other menu, press the SELECT key until the MONITOR MENU appears. When at this screen, press the UP or DOWN key for monitoring any of the operating parameters.

### 8.3 Acknowledging Trips and Alarms

If an alarm or trip condition occurs, it will automatically be displayed on the display unit regardless of the screen selection.

To acknowledge an ALARM, the ENTER key must be pressed while in the MONITOR menu displaying the "Alarm - Enter = Ack" parameter or by pressing the "RESET" button on the DBS control board.

To acknowledge a TRIP, the ENTER key must be pressed while in the MONITOR menu displaying the "Trip - Enter = Ack" parameter or by pressing the "RESET" button on the DBS control board. A message confirming that the trip/alarm has been acknowledged will then be displayed to the screen.

# RAM DBS

---

## Solid State Starter

### 8.4 Editing Set Points

The DBS provides easy access to operating and set-up parameters through the use of the edit mode. The edit mode is entered when the ENTER key is pressed while in any of the SET POINT menu parameters. The word “edit” will appear in the lower left status code area of the display screen.

Next, the UP or DOWN key should be pressed to increment or decrement the value stored as the set point. Once the desired value of the set point is displayed to the screen, the ENTER key must be pressed to save that value as the new set point.

Pressing the SELECT key at any time while in the edit mode will abort the edit. The current menu parameter will be set to the value that was stored before the edit mode was entered.

**NOTE: The EDIT mode cannot be entered while the DBS is in the START or RUN operating states.**

### 8.5 Confirming System Setup Options

Within the SYSTEM SETUP menu, there are three parameters which can be controlled by the Display Unit. To clear the Thermal Capacity, Clear the Fault History, or to Load the Factory Setup, press the ENTER key while in the corresponding screen display. In each case, a confirmation screen will then be displayed to acknowledge that the option has been selected.

# RAM DBS

## Solid State Starter

### 9.0 DBS Display Unit

**TABLE 11 Monitor Menu**

This menu is used to display the current system conditions as seen by the DBS.

<b>SELECTION</b>	<b>UNITS</b>
Average Current	Amps
Current Phase A	Amps
Current Phase B	Amps
Current Phase C	Amps
Elapsed Run Time (since last start)	Hr:Min
Thermal Capacity Used	%Cap
Heatsink Temperature	DegC
Time Till Start	Minutes
Alarm - Enter = Ack	
Trip - Enter = Ack	

**TABLE 12 Set Point Menu**

This menu displays the set point values programmed into the DBS. Changes to any system set point must be made from this menu in the "edit" mode.

<b>SELECTION</b>	<b>RANGE</b>	<b>DEFAULT</b>	<b>UNITS</b>
Locked Rotor Current	300 - 800	600	%FLA
Stall Time	1 - 60	10	Seconds
Jam Current Level	100 - 600	300	%FLA
Jam Run Delay	0 - 60	10	Seconds
*Service Factor	75 - 125	115	%FLA
Current Unbalance Level	2 - 25	25	%FLA
Current Unbalance Delay	0 - 240	5	Seconds

**\*NOTE: Maximum Service Factor of 125% for FLA Switch #0-8, 115% for FLA Switch #9-B, 100% for FLA Switch #C-F.**



# RAM DBS

## Solid State Starter

### 9.0 DBS Display Unit (continued)

**TABLE 13 Fault History**

This menu displays the fault history of the system. The information stored here can be of great value in troubleshooting.

<b>SELECTION</b>	<b>UNITS</b>
Last Trip Condition	
Last Trip Current	Amps
Last Trip Heatsink Temperature	DegC
Last Trip Thermal Capacity	DegC
Last Trip FLA	%Cap
Last Trip Current Step	Amps
Last Trip Ramp Time	%FLA
Last Trip Bypass Time	Seconds
Last Trip Run Time	Seconds
Total No. of Starts	Hr:Min
Total Run Time	
Total No. of Jam Trips	Hr:Min
Total No. of Short Circuit Trips	
Total No. of Phase Loss Trips	
Total No. of Phase Reversal Trips	
Total No. of Current Unbalance Alarms	
Total No. of Heatsink Overtemperature Trips	
Total No. of Thermal Overload Trips	

**TABLE 14 System Setup Menu**

This menu displays the current system setup as seen by the DBS.

<b>SELECTION</b>	<b>OPTIONS</b>
*Full Load Amps	(See FLA-Starter Size Table 9) - (SW1)
*Start Mode	Constant Current / Step Ramp - (SW4)
*Constant Current Level	200 - 425% - (SW2)
*Ramp Time	3 - 30 Sec. - (SW3)
*Bypass Time	3 - 30 Sec. - (SW3)
*Starter Size	(SW6)
*Thermal Overload Protection	Enable - Disable - (SW4)
*Inline Configuration	(SW4)
*Control Mode	Local/Display/Network (SW4)
Software Version	
Clear Fault History	Yes - No
Clear Thermal Capacity	Yes - No
Load Factory Setup	Yes - No

\*Indicates setting is controlled by circuit board switches on main control board.

# RAM DBS

## Solid State Starter

### 10.0 RAM DBS Log

Serial Number \_\_\_\_\_

#### Switch Settings

(Copy settings as currently set on main control board)

Switch 1 - FLA	_____	(Sw Pos)
Switch 2 - Current Step	_____	(Sw Pos)
Switch 3 - Ramp Time	_____	(Sw Pos)
Switch 4 - Configuration Dipswitch		(Circle Switch Position)
Pos 1	LEFT/RIGHT	
Pos 2	LEFT/RIGHT	
Pos 3	LEFT/RIGHT	
Pos 4	LEFT/RIGHT	
Pos 5	LEFT/RIGHT	
Pos 6	LEFT/RIGHT	
Pos 7	LEFT/RIGHT	
Pos 8	LEFT/RIGHT	

#### Fault History Menu

	Setting	
Last Trip Condition	_____	
Last Trip Current	_____	Amps
Last Trip Heatsink Temperature	_____	DegC
Last Trip Thermal Capacity	_____	% Cap
Last Trip FLA	_____	Amps
Last Trip Current Step	_____	% FLA
Last Trip Ramp Time	_____	Seconds
Last Trip Bypass Time	_____	Seconds
Last Run Time	_____	Minutes
Total No. of Starts	_____	
Total Run Time	_____	Hours
Total No. of Jam Trips	_____	
Total No. of Short Circuit Trips	_____	
Total No. of Phase Loss Trips	_____	
Total No. of Phase Reversal Trips	_____	
Total No. of Current Unbalance Alarms	_____	
Total No. of Heatsink Temperature Trips	_____	
Total No. of Thermal Overload Trips	_____	

#### Set Point Menu

	Setting	
Locked Rotor Current	_____	% FLA
Stall Time	_____	Seconds
Jam Current Level	_____	% FLA
Jam Run Delay	_____	Seconds
Service Factor	_____	% FLA
Current Unbalance Level	_____	% FLA
Current Unbalance Run Delay	_____	Seconds

#### System Setup Menu

	Setting	
FLA	_____	Amps
Start Mode	_____	
Constant Current Level	_____	% FLA
Ramp Time	_____	Seconds
Bypass Time	_____	Seconds
Starter Size	_____	
Thermal Overload	_____	
Motor Configuration	_____	
Control Mode	_____	
Software Version	_____	

## 11.0 Maintenance



**WARNING:** Disconnect all incoming power to this equipment and lock-out and tag circuits prior to performing preventive maintenance. Discharge capacitors, if present. Positively ascertain that the equipment is totally de-energized, including possible foreign sources by using appropriate metering.

- For equipment to operate properly, and to reduce unscheduled down-time, a periodic maintenance program should be established. NFPA Publication 70B (Electrical Equipment Maintenance) may be used as a guide.
- It is recommended that at least once each year the following steps be taken.

### Enclosures

- Carefully inspect all enclosure surfaces for signs of excessive heat. As a general rule of thumb, any temperature which the palm of the hand cannot stand for about 3 seconds may indicate a problem.
- Check all cabinet doors to assure proper operation and that all door latching and/or locking devices are in proper working order.
- Look inside cabinets for any signs of moisture, dripping, or condensation. Seal off any conduits which may have dripped condensate or provide an alternate means for drainage. Seal off any cracks or openings which may have allowed moisture to enter the enclosure and eliminate the source of moisture on the outside of the enclosure.
- Thoroughly dry all cabinet surfaces which may be damp or wet. If accumulated deposits are apparent, conduct an electrical insulation test to assure proper insulation integrity.
- If there is an accumulation of dust, remove with a vacuum cleaner or clean with lint-free rags. Do not attempt to use compressed air as it may contaminate other internal components.

### Wiring

- Inspect all accessible wiring for signs of looseness or overheating. Re-tighten to proper torque values as required. If major discoloration of wire insulation or cable damage is apparent, replace the affected cable.
- Identify and re-mark all cables in accordance with equipment drawings where required.

### Disconnecting Means

- Inspect all terminations for signs of looseness or overheating. Re-tighten to proper torque values as required.
- Operate each device manually to assure proper operation and test manual trip feature, if equipped. Check for proper trip settings and adjust if required. Assure that any insulators or arc barriers are intact and in place.
- Molded case circuit breaker should be kept clean of external contamination.
- If any cracks in its case are visible, the circuit breaker should be replaced.

# RAM DBS

---

## Solid State Starter

### Fuses

- Examine all fuse clips and fuse blocks for signs of overheating or looseness. If there is any indication of reduced spring tension or overheating, replace the fuse clips or fuse block assembly.
- Assure that all fuses are the correct type and the proper size as listed on devices and applicable drawings.

### Contactors and Relays

- If there is an accumulation of dust, remove with a vacuum cleaner or clean with lint-free rags. Do not attempt to use compressed air as it may contaminate other internal components.
- Check all component terminals for signs of looseness or overheating and re-torque to proper values as required. If terminal is badly discolored, it may indicate that a high resistance joint or contact exists. Remove the arc chutes on the device to inspect contact condition.
- Inspect all accessible devices for breakage, cracks, or signs of sooty deposits, spattering, or carbon tracking. Clean all affected surfaces and replace damaged or cracked components.
- Inspect contact condition for signs of excessive heating, uneven wear, or unequal spring tension. Indications of light sooty deposits, minor pitting, or material displacement do not indicate a problem if all surfaces are worn equally. Do not attempt to file or dress contact surfaces with abrasives, as this will likely increase the wear rate of the contacts.
- Manually operate all power contactors and check wear indicators, if equipped. If wear indicators show 50% or less remaining life, or if contact surfaces indicate excessive or uneven wear, all contacts and spring carriers should be replaced.
- Assure that all contact screws are tightened and all barriers and arc chutes are replaced.

### General

- List all component part numbers which may be showing signs of wear, and order replacements for installation at next scheduled shut-down period.
- Note any equipment additions and/or wiring modifications on the appropriate drawings, for maintenance use and troubleshooting.

### Electronic Equipment

- Inspect circuit boards for signs of overheating such as discoloration.
- Look for evidence of moisture or corrosion.
- Eliminate any accumulations of dust, especially between connecting terminals, with a vacuum cleaner. Do not use solvents on printed circuit boards.
- Test tightness of screw terminal connections by slightly pulling on the wire.

# RAM DBS

## Solid State Starter

### Maintenance After a Fault Has Occurred



**CAUTION!** After a fault has occurred, all equipment must be de-energized, disconnected, and isolated to prevent accidental contact with live parts. Check voltage on all terminals before touching or working on equipment. Only qualified individuals should be involved in the inspection and repair procedures and all safety precautions must be observed.

- The excessive currents occurring during a fault may result in enclosure, component, and/or conductor damage due to mechanical distortion, thermal damage, metal deposits, or smoke. After a fault, determine the cause, inspect, and make any necessary repairs or replacements prior to re-commissioning this equipment. The following procedure is recommended for this inspection.

#### Enclosure

- Check cabinet exterior for any signs of deformation or heat damage. Assure that all hinges and cabinet latching and/or locking mechanisms are in working order. Replace affected parts if required.

#### Disconnecting Means

- The externally mounted disconnect operator handle must be capable of opening the circuit breaker. Inspect all door interlocks for proper function. Replace operator mechanism, door interlock, and related parts that show signs of binding, warping, or abnormal wear.
- Inspect circuit breakers for any signs of damage or deterioration. If it is suspected that the circuit breaker has opened several short circuits, it should be replaced.
- After replacing damaged components, operate disconnect device several times to assure all mechanisms work properly.

#### Fuses

- Always replace all three fuses in a three phase circuit, even though only one or two are open. Possible heat damage in the remaining fuse(s) could result in a subsequent shutdown.

#### Terminals and Internal Conductors

- Replace all damaged parts which show signs of discoloration, melting, or arcing damage.

#### Contactors and Relays

- Replace all contacts and contact springs if inspection shows signs of welding, displacement of metal, heat damage, or excessive wear. If device shows any signs of binding, or arcing and flash damage, replace the entire component. Perform an insulation resistance test to verify insulation integrity.

#### Overloads

- Visually inspect all overload devices for signs of arcing or other heat damage. If there is any sign of arcing or burning on the overload, or if burnout of the heater element has occurred, the entire overload device must be replaced.

#### Restoring to Service

- Before restoring the equipment to service, it is recommended that the steps outlined in procedures for START-UP are followed.

# RAM DBS

## Solid State Starter

### 12.0 Replacement Parts

DBS Chassis Sizes B1, B2, B3, C1, C2, C3  
with RAM Contactor

TABLE REVISED JAN 08

Item	Replacement Parts	B1	B2	B3	C1	C2	C3
1	Circuit Board Set	RAM-400339-AF	RAM-400339-AF	RAM-400339-AF	RAM-400339-AF	RAM-400339-AF	RAM-400339-AF
2	Bypass Contactor	RI1-F115A-120	RI1-F150A-120	RI1-F185A-120	RI1-F150A-120	RI1-F185A-120	RI1-F265A-120
3	Aux Contact	RI1D-N11	RI1D-N11	RI1D-N11	RI1D-N11	RI1D-N11	RI1D-N11
4	Load Lug (Left)	TL-0243	TL-0244	TL-0244	TL-0255	TL-0255	TL-0258
5	Load Lug (Center)	TL-0243	TL-0244	TL-0244	TL-0253	TL-0253	TL-0256
6	Load Lug (Right)	TL-0243	TL-0244	TL-0244	TL-0254	TL-0254	TL-0257
7	Current Transformer	XF-0196	XF-0198	XF-0198	XF-0199	XF-0302	XF-0303
8	SCR Module (Eupec)	CR-0096	CR-0096	CR-0096	CR-0097	CR-0097	CR-0097
8a	SCR Module (Jinglai)	CR-0140	CR-0140	CR-0140	CR-0141	CR-0141	CR-0141
9	Temp Sensor Harness	HA-0877	HA-0877	HA-0877	HA-0877	HA-0877	HA-0877
10	Temp Sensor	IC-0036	IC-0036	IC-0036	IC-0036	IC-0036	IC-0036
11	Thermostat Harness	HA-0879	HA-0879	HA-0879	HA-0879	HA-0879	HA-0879
12	Thermostat	SW-0345	SW-0345	SW-0345	SW-0345	SW-0345	SW-0345
13	Gate Leads (Eupec-Right)	HA-0872	HA-0872	HA-0872	HA-0881	HA-0881	HA-0881
13a	Gate Leads (Jinglai-Right)	HA-400663-01	HA-400663-01	HA-400663-01	HA-400663-02	HA-400663-02	HA-400663-02
14	Gate Leads (Eupec-Left)	HA-0873	HA-0873	HA-0873	HA-0882	HA-0882	HA-0882
14a	Gate Leads (Jinglai-Left)	HA-400664-01	HA-400664-01	HA-400664-01	HA-400664-02	HA-400664-02	HA-400664-02

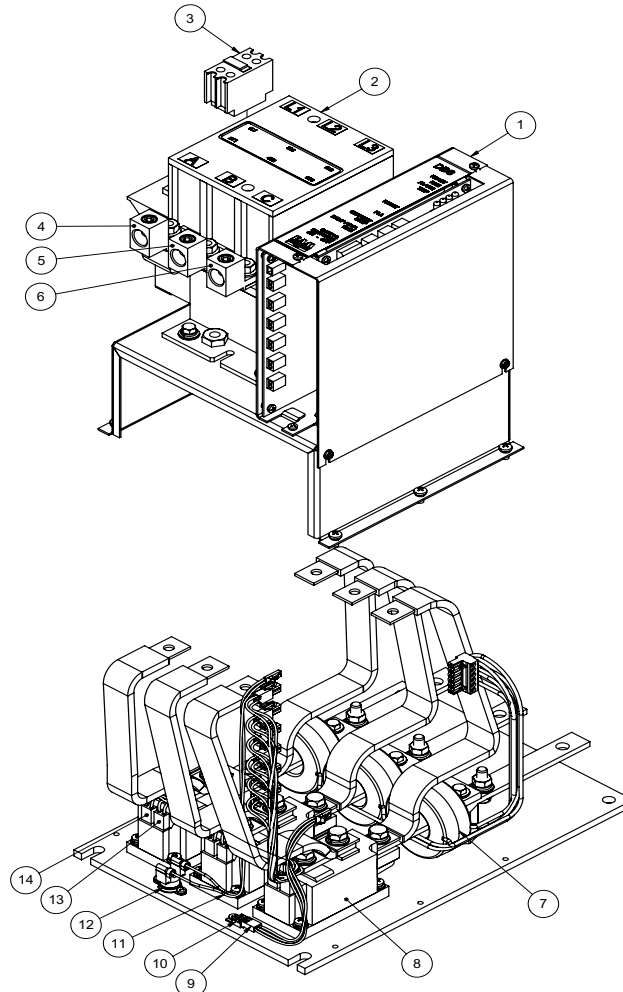

209036 A

# RAM DBS

## Solid State Starter

### 11.0 Replacement Parts (continued)

DBS Chassis Sizes D1, D2, D3, E1, E2, E3  
with RAM Contactor

TABLE REVISED JAN 08

Item	Replacement Parts	D1-1	D1 or D2	D3	E1	E2	E3
1	Circuit Board Set	RAM-400339-AF	RAM-400339-AF	RAM-400339-AF	RAM-400339-AF	RAM-400339-AF	RAM-400339-AF
2	Bypass Contactor	RI1-F330A-120	RI1-F400A-120	RI1-F500A-120	RI1-F630A-120	RI1-F630A-120	RI1-F630A-120
3	Aux Contact	RI1D-N11	RI1D-N11	RI1D-N11	RI1D-N11	RI1D-N11	RI1D-N11
4	Load Lug (Left)	TL-0263	TL-0263	TL-0247	TL-0248	TL-0248	TL-0248
5	Load Lug (Center)	TL-0261	TL-0261	TL-0247	TL-0249	TL-0249	TL-0249
6	Load Lug (Right)	TL-0262	TL-0262	TL-0247	TL-0250	TL-0250	TL-0250
7	Current Transformer	XF-0210	XF-0210	XF-0202	XF-0203	XF-0203	XF-0203
8	SCR (Eupec)	CR-0109	CR-0109	CR-0110	CR-0110	CR-0110	CR-0132
8a	SCR (Jinglai)	CR-0142	CR-0143	CR-0143	CR-0143	CR-0144	CR-0144
9	Thermostat Harness	HA-0880	HA-0880	HA-0880	HA-0880	HA-0880	HA-0880
10	Thermostat	SW-0345	SW-0345	SW-0345	SW-0345	SW-0345	SW-0345
11	Temp Sensor	IC-0036	IC-0036	IC-0036	IC-0036	IC-0036	IC-0036
12	Temp Sensor Harness	HA-0878	HA-0878	HA-0878	HA-0878	HA-0878	HA-0878
13	Gate Leads (Eupec-Long)	HA-0875	HA-0875	HA-0875	HA-0875	HA-0875	HA-0875
13a	Gate Leads (Jinglai-Long)	HA-400665-02	HA-400665-02	HA-400665-02	HA-400665-02	HA-400665-02	HA-400665-02
14	Gate Leads (Eupec-Short)	HA-0876	HA-0876	HA-0876	HA-0876	HA-0876	HA-0876
14a	Gate Leads (Jinglai-Short)	HA-400665-01	HA-400665-01	HA-400665-01	HA-400665-01	HA-400665-01	HA-400665-01
15	Baseplate Insulator (3/8" bolt)	HD-0637	HD-0637	HD-0637	HD-0637	HD-0637	HD-0637
15a	Baseplate Insulator (1/2" bolt)	HD-400506	HD-400506	HD-400506	HD-400506	HD-400506	HD-400506

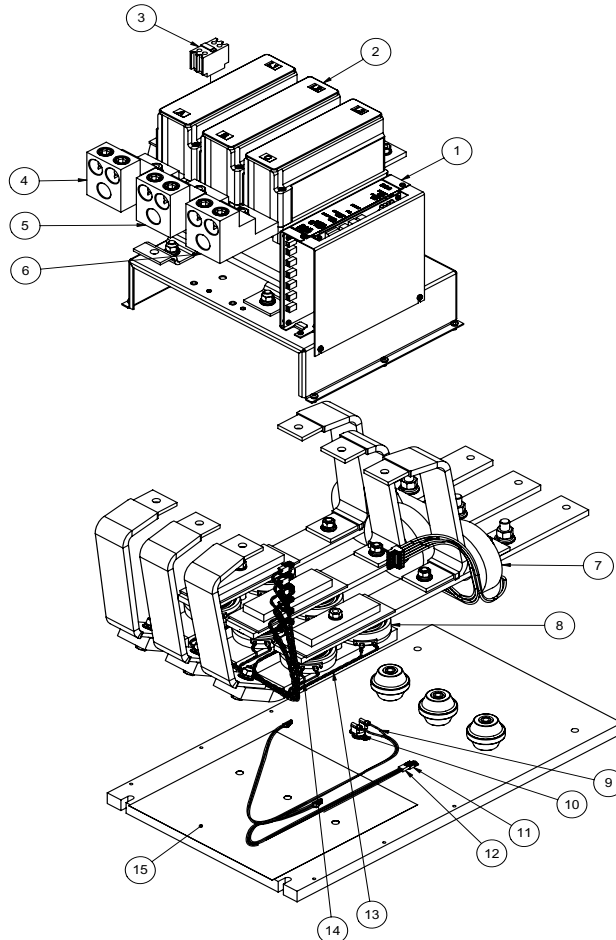

209038A

# RAM DBS

## Solid State Starter

### 11.0 Replacement Parts (continued)

DBS Chassis Sizes D1, D2, D3, E1, E2, E3  
with ABB Contactor

TABLE REVISED JAN 08

Item	Replacement Parts	D1-1	D1 or D2	D3	E1	E2	E3
1	Circuit Board Set	RAM-400339-AF	RAM-400339-AF	RAM-400339-AF	RAM-400339-AF	RAM-400339-AF	RAM-400339-AF
2	Bypass Contactor	CT-0794	CT-0795	CT-0796	CT-0797	CT-0798	CT-798
3	Aux Contact	CT-0895	CT-0895	CT-0895	CT-0895	CT-0895	CT-0895
4	Load Lug Kit (3)	TL-0234	TL-0235	TL-0235	TL-0236	TL-0236	TL-0236
5	Current Transformer	XF-0210	XF-0210	XF-0202	XF-0203	XF-0203	XF-0203
6	SCR (Eupec)	CR-0109	CR-0109	CR-0110	CR-0110	CR-0110	CR-0132
6a	SCR (Jinglai)	CR-0142	CR-0143	CR-0143	CR-0143	CR-0144	CR-0144
7	Thermostat Harness	HA-0880	HA-0880	HA-0880	HA-0880	HA-0880	HA-0880
8	Thermostat	SW-0345	SW-0345	SW-0345	SW-0345	SW-0345	SW-0345
9	Temp Sensor	IC-0036	IC-0036	IC-0036	IC-0036	IC-0036	IC-0036
10	Temp Sensor Harness	HA-0878	HA-0878	HA-0878	HA-0878	HA-0878	HA-0878
11	Gate Leads (Eupec-Long)	HA-0875	HA-0875	HA-0875	HA-0875	HA-0875	HA-0875
11a	Gate Leads (Jinglai-Long)	HA-400665-02	HA-400665-02	HA-400665-02	HA-400665-02	HA-400665-02	HA-400665-02
12	Gate Leads (Eupec-Short)	HA-0876	HA-0876	HA-0876	HA-0876	HA-0876	HA-0876
12a	Gate Leads (Jinglai-Short)	HA-400665-01	HA-400665-01	HA-400665-01	HA-400665-01	HA-400665-01	HA-400665-01
13	Baseplate Insulator (3/8" bolt)	HD-0637	HD-0637	HD-0637	HD-0637	HD-0637	HD-0637
13a	Baseplate Insulator (1/2" bolt)	HD-400506	HD400506	HD400506	HD400506	HD400506	HD400506

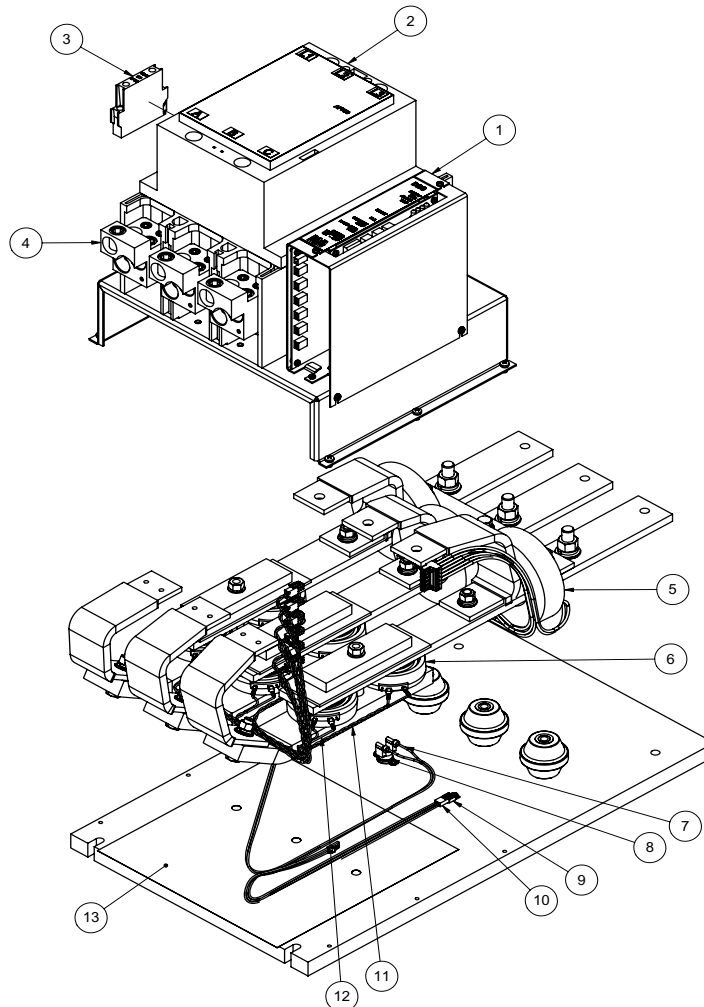

209037 A



# RAM DBS

## Solid State Starter

### Appendix A

FIGURE 9 **Starter Size Dipswitch Positions**  
to Determine Starter Size

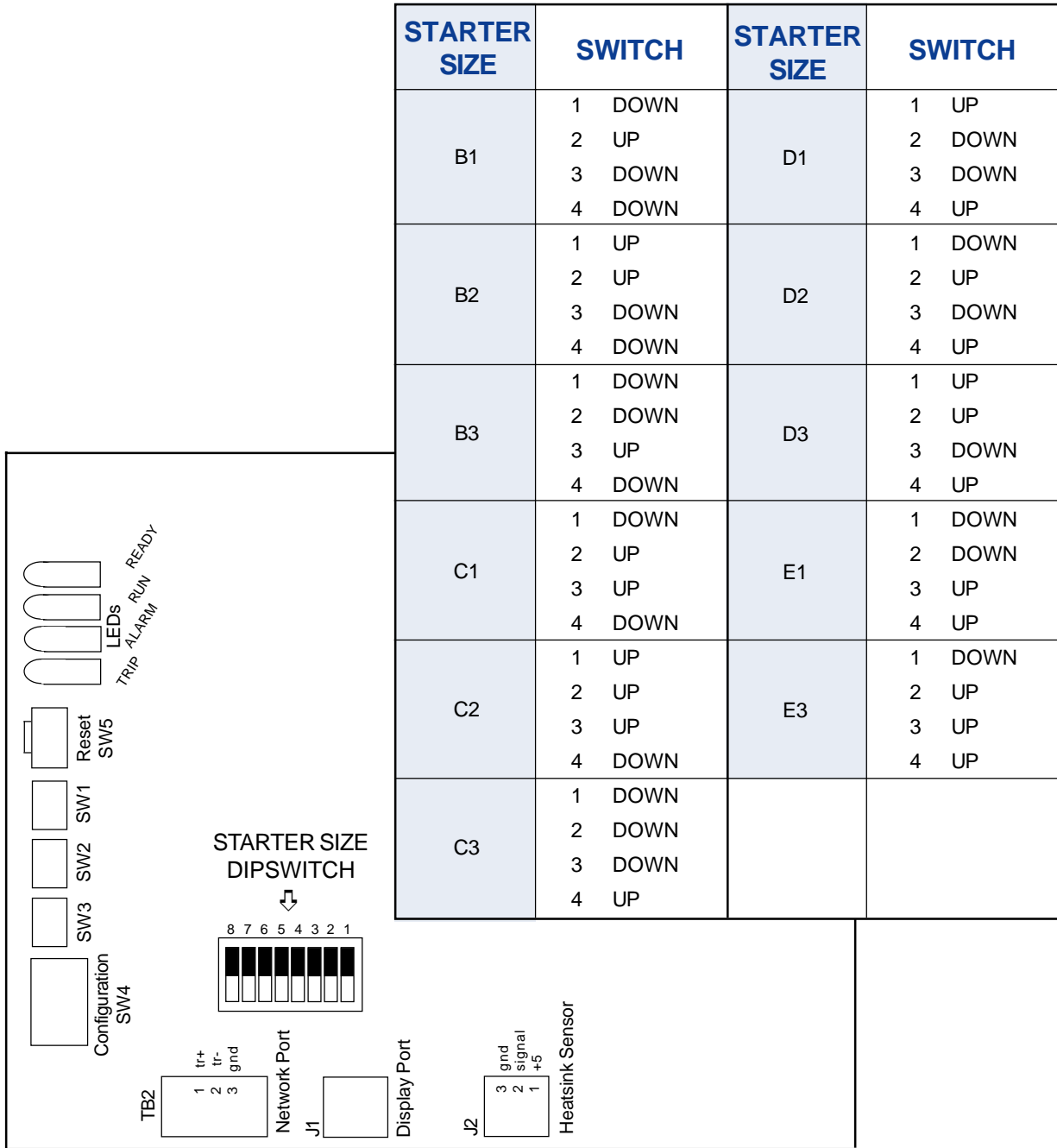

Starter size DIP switch is located on the interior of the board (SW6). UP / DOWN orientation of switches as seen when looking at the boards as seen in Section 5, Figure 8. SW6 is positioned horizontally toward the bottom of the board. Switch position #1 is farthest from the front edge of the board.

This switch is factory preset and shouldn't be changed without factory approval.

# RAM DBS

## Solid State Starter

### Appendix B

FIGURE 10

### Typical Motor Connections 3 Wire Inline Configuration

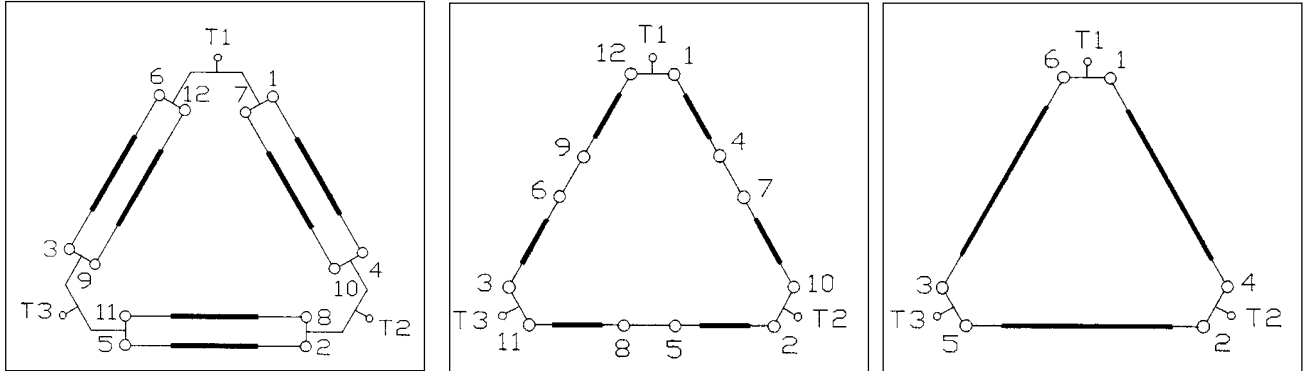

**12 Lead  
Parallel Connection**

**12 Lead  
Series Connection  
(Dual Voltage)**

**Typical  
6 Lead Motor**

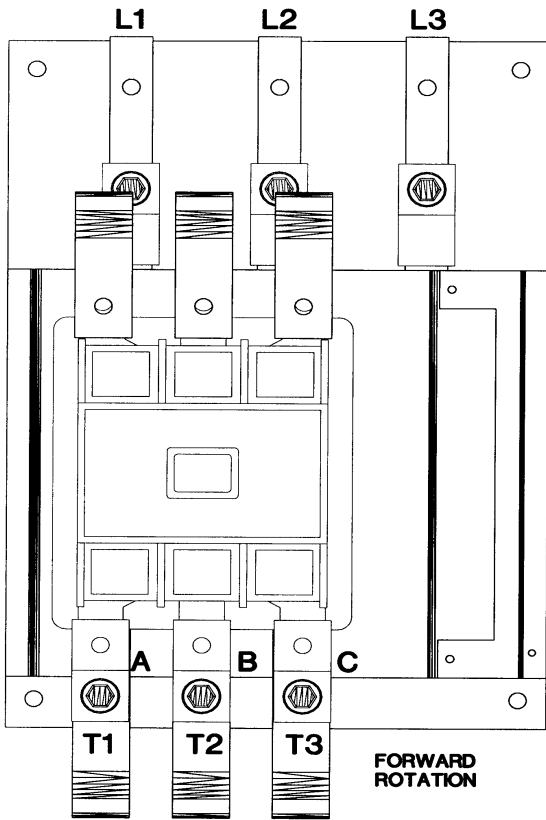

**FORWARD  
ROTATION**

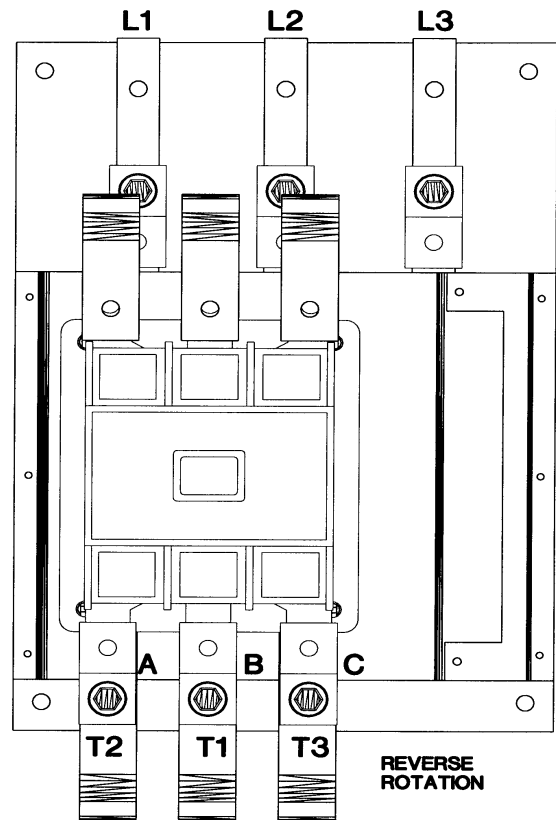

**REVERSE  
ROTATION**

**Typical Connection**

### Appendix C

## SCR Test Procedure

**DANGER! Hazard of Burn or Electrical Shock. Make certain that all incoming sources of power have been disconnected, locked out, and tagged prior to working on this equipment.**

1. Make sure that all power sources are turned off and properly locked out.
2. Remove the motor leads.
3. Remove the cover of the bypass contactor and assure that the contacts are not welded together. The contacts should move freely without any restriction while pushing on the armature of the contactor.
4. Remove the six gate leads from the control board, taking note of their order. They should be numbered from 3 to 8. If the gate lead connectors are not removed, false measurements will result while checking the SCRs.
5. A 500 volt megger or a Simpson analog multi meter is required to properly test the SCRs. If an analog meter is used, select the highest resistance scale (R x 10,000 scale).
6. Start by measuring from L1 to T1. Reverse the polarity of the meter leads and measure again. The readings should be about the same. Repeat the measurements from L2 to T2 and L3 to T3. The measurements should be no lower than 1 megohm.
7. Measure L1, L2, L3, T1, T2, and T3 individually to ground. There should be an open circuit or an infinite reading on the meter.
8. Set the meter on its lowest scale (R x 1 ohm). Carefully measure all six gate leads. Measure the red and white gate lead, switch the polarity of the meter leads and measure again. About 8 to 20 ohms should be measured in both directions. The readings should be within an ohm or two of each other. Be careful not to spread apart the female plug with the meter leads when testing. This could cause the plug to become loose, resulting in the misfiring of the SCRs when in operation.

# RAM DBS

---

## Solid State Starter

### Glossary

**Across-the Line** - Method of motor starting which connects the motor directly to the supply line while starting or running. (Also called Full-Voltage Control)

**Alarm** - A warning signal that an undesirable condition has been detected. The alarm LED will blink when an alarm condition is detected. See Section 1.6 for more alarm LED information.

**Ambient Temperature** - The temperature surrounding a device.

**Average Current** - The current measured at each of the three current inputs, averaged together, and displayed as an rms value.

**Bypass Time** - The length of time that must expire after the motor is started to cause the bypass contactor to engage.

**Constant Current Mode** - In this mode, the starting motor current is maintained at a constant level. When the motor is at full speed, the current is determined by the motor load.

**Current Phase A** - The “live” current reading for Phase A.

**Current Step** - The initial current limit value of the controller when the DBS is in either the Constant Current or Step Ramp mode. When in Constant Current mode, this current limit is maintained until the motor reaches full speed. In Step Ramp mode, this value sets the initial ramp level limit and then allows the controller to continue the ramp to 500%.

**Current Unbalance** - When any one of the three current phases exceeds the average of the three current phases by more than a predetermined percentage.

**Elapsed Run Time** - The time that has expired since the unit has entered the Start state.

**Fault** - An undesirable condition that will cause an Alarm or a Trip to occur.

**FLA (Full Load Amps)** - The amount of current normally drawn by a motor when at rated load and voltage.

**Heatsink** - Metal used to dissipate the heat of solid-state components mounted on it.

**Inline Configuration** - A method of connecting the leads of a three-phase motor which places the SCRs between the connected motor windings and the three lines of incoming power. In this type of arrangement, all of the current to the motor passes through the SCRs (also known as outside connected).

**Jam** - An increase in motor load which causes the current to rise significantly.

**Jam Current Level** - The percentage of FLA that the average of the three current phases is allowed to reach during the Run state.

**Jam Run Delay** - The length of time during the Run state that the current must be above the Jam Current Level to cause a fault.

# RAM DBS

---

## Solid State Starter

### Glossary

**LCD (Liquid Crystal Display)** - A readout device in which each digit is formed by strips of liquid-crystal material.

**LRC (Locked Rotor Current)** - The steady-state current taken from the line with the rotor locked (stopped) and with the rated voltage and frequency applied to the motor. This is the motor manufacturer's specified current draw for a stalled motor.

**NEMA** - National Electrical Manufacturers Association.

**Phase Loss** - A condition when a loss of current or voltage has been detected in a polyphase circuit.

**Phase Reversal** - A condition when incorrect phase rotation has been detected in a polyphase circuit.

**PLL** - A phase-locked loop (PLL) is an electronic circuit that is constantly adjusted to match the frequency of an input signal.

**RTD (Resistive Temperature Device)** - A temperature-sensing input device.

**SCR (Silicon Controlled Rectifiers)** - A semiconductor device that must be triggered by a pulse applied to the gate before it will conduct.

**Service Factor** - An allowable overload; the amount of allowable overload is indicated by a multiplier which, when applied to a normal FLA rating, indicates the permissible loading.

**Stall Time** - The maximum time at which the motor can be at locked rotor current without damage.

**Step Ramp Mode** - In this mode, the starter provides an initial current that is a percent of FLA. The current is then ramped from its initial current setting to 500% over an adjustable time period. When the motor is at full speed, the current is then determined by the motor load.

**Thermal Capacity** - The allowable amount of thermal energy that can be absorbed before damage may occur to the motor.

**Thermal Capacity Used** - The calculated thermal capacity used by the motor.

**Thermal Overload Level** - The percentage of thermal capacity that has been consumed. This level is calculated using the average of the 3-phase currents and the time that the current level exists. It is also dependent on the Locked Rotor Current, Stall Time, and the FLA settings. NOTE: Heating from motor starting current normally consumes a large percentage of the thermal capacity. Repetitive starts in a short time span can exhaust the thermal capacity.

**Trip** - An undesirable condition that could result in damage to the motor. A trip condition will stop the motor if it is running and not allow the motor to start until the cause of the trip condition is cleared.

# RAM DBS

---

Solid State Starter

## Notes

# RAM DBS

---

Solid State Starter

## Notes



RT. 61 • PO Box 629 • Leesport, PA 19533  
800-999-8183 • [www.ramusa.com](http://www.ramusa.com)  
(610) 916-3939 • FAX (610) 926-9799

INLINE / JAN 08 / REV 8  
SUPERSEDES JULY 07 / REV 7