

GARMIN®

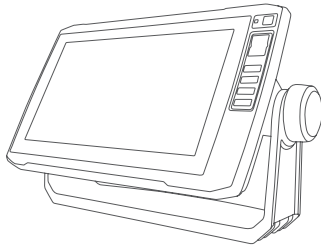

## ECHOMAP™ PLUS 60/70/90 SERIES INSTALLATION INSTRUCTIONS

### Important Safety Information

#### ⚠ WARNING

See the *Important Safety and Product Information* guide in the product box for product warnings and other important information.

When connecting the power cable, do not remove the in-line fuse holder. To prevent the possibility of injury or product damage caused by fire or overheating, the appropriate fuse must be in place as indicated in the product specifications. In addition, connecting the power cable without the appropriate fuse in place voids the product warranty.

#### ⚠ CAUTION

Always wear safety goggles, ear protection, and a dust mask when drilling, cutting, or sanding.

#### NOTICE

When drilling or cutting, always check what is on the opposite side of the surface.

To obtain the best performance and to avoid damage to your boat, install the device according to these instructions.

Read all installation instructions before proceeding with the installation. If you experience difficulty during the installation, contact Garmin® Product Support.

#### Tools Needed

- Drill
- Drill bits
  - Bail mount: drill bits appropriate for the surface and hardware
  - Swivel mount: 3 mm (1/8 in.) drill bit
  - Flush mount: 3 mm (1/8 in.) and 9.5 mm (3/8 in.) drill bits
- #2 Phillips screwdriver
- Jigsaw or rotary tool
- File and sandpaper
- Marine sealant (optional)

### Mounting Considerations

You can mount the device using one of three methods.

**Bail mount:** You can mount the device using the bail mount, which allows you to tilt the device.

**Swivel mount:** You can mount the device using the swivel base and bail mount, which allows you to swivel and tilt the device. Not available on the ECHOMAP Plus 9x models.

**Flush mount:** You can mount the device in the dashboard, which provides a more integrated installation.

Before permanently installing any part of your device, you should plan the installation by determining the location of the various components.

- The mounting location must provide a clear view of the screen and access to the keys on the device.
- The mounting location must be sturdy enough to support the device and the mount.
- The cables must be long enough to connect the components to each other and to power.
- To avoid interference with a magnetic compass, do not install the device closer to a compass than the compass-safe distance value listed in the product specifications.

### Fixed-Bail Mounting the Device

#### NOTICE

If you are mounting the bracket on fiberglass with screws, it is recommended to use a countersink bit to drill a clearance counterbore through only the top gel-coat layer. This will help to avoid cracking in the gel-coat layer when the screws are tightened.

Stainless-steel screws may bind when screwed into fiberglass and overtightened. It is recommended to apply an anti-seize lubricant on the screws before installing them.

- 1 Select the mounting hardware appropriate for your mounting surface and for the bail-mount bracket.
- 2 Using the bail-mount bracket as a template, mark the pilot holes through the screw holes.
- 3 Using a drill bit appropriate for the mounting hardware, drill the four pilot holes.
- 4 Using the selected mounting hardware, secure the bail-mount bracket to the mounting surface.
- 5 Install the bail-mount knobs ① on the sides of the cradle.

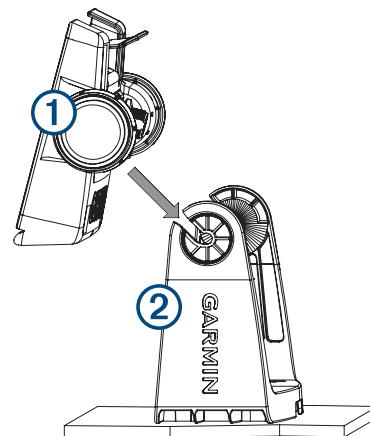

- 6 Place the cradle into the bail-mount bracket ②, and tighten the bail-mount knobs.

TRA  
REGISTERED No:  
ER59438/17  
DEALER No:  
DA0015955/08



- 7 Connect each cable to a port on the cradle, using the locking bracket or locking rings to secure the cables to the cradle (*Installing the Cables and Connectors*, page 2).

## Bail Mounting a Device with a Swivel Base

### NOTICE

Only pan-head machine bolts or self-tapping screws should be used to secure the swivel base. If you use screws with countersunk heads, you may damage the mounting bracket.

Some models have the option of adding a swivel base to the bail mount, so you can turn the device for a wider range of viewing angles.

**NOTE:** The ECHOMAP Plus 9x models do not have a swivel option.

- 1 Using the swivel base ① as a template, mark three pilot holes ②.

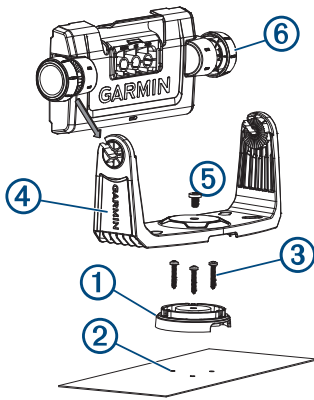

- 2 Using a 3 mm ( $1/8$  in.) drill bit, drill the three pilot holes.
- 3 Using the included wood screws ③, secure the swivel base to the mounting surface.
- 4 Place the bail-mount bracket ④ on the swivel base, and secure it using the swivel-mount knob ⑤.
- 5 Install the bail-mount knobs ⑥ on the sides of the cradle.
- 6 Place the device in the bail-mount bracket and tighten the bail-mount knobs.
- 7 Connect each cable to a port on the cradle, using the locking bracket or locking rings to secure the cables to the cradle (*Installing the Cables and Connectors*, page 2).

## Flush Mounting the Device

### NOTICE

Be careful when cutting the hole to flush mount the device. There is only a small amount of clearance between the case and the mounting holes, and cutting the hole too large could compromise the stability of the device after it is mounted.

Using a metal pry tool such as a screwdriver can damage the trim caps and the device. Use a plastic pry tool when possible.

You can mount the device in your dashboard using the flush-mount template and appropriate hardware.

- 1 Trim the template and make sure it fits in the location where you want to mount the device.
- 2 Secure the template to the mounting location.
- 3 Using a 9.5 mm ( $3/8$  in.) drill bit, drill one or more of the holes inside the corners of the solid line on the template to prepare the mounting surface for cutting.
- 4 Using a jigsaw or rotary cutting tool, cut the mounting surface along the inside of the solid line indicated on the template.
- 5 Place the device into the cutout to test the fit.

- 6 If necessary, use a file and sandpaper to refine the size of the hole.
- 7 If your device has trim caps, use a pry tool, such as a flat piece of plastic or a screwdriver, to carefully pry up the corners of the trim caps ①, slide the pry tool to the center ②, and remove the trim caps.

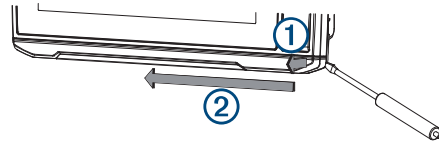

- 8 Ensure the mounting holes on the device line up with the pilot holes on the template.
- 9 If the mounting holes on the device do not line up with the pilot holes on the template, mark the new pilot-hole locations on your template.
- 10 Using a 3 mm ( $1/8$  in.) drill bit, drill the pilot holes.
- 11 Remove the template from the mounting surface.
- 12 Place the device in the cradle.
 

**NOTE:** You must use the cradle and locking bracket or locking rings when you flush-mount the device.
- 13 If you will not have access to the back of the device after you mount it, connect all necessary cables to the cradle and secure the cables with the locking bracket or locking rings before placing the device into the cutout (*Installing the Cables and Connectors*, page 2).
- 14 To prevent corrosion of the metal contacts, cover unused connectors with weather caps (ECHOMAP Plus 7x/9x models only).
- 15 Install the rubber gasket pieces on the back of the device.
 

The pieces of the rubber gasket have adhesive on the back. Make sure you remove the protective liner before installing them on the device.

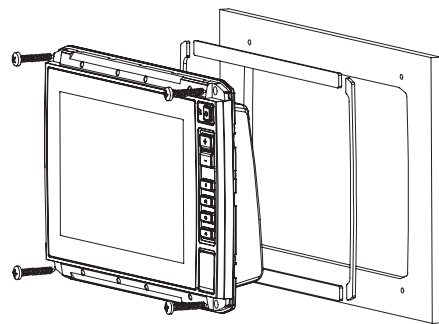

- 16 Connect each cable to a port on the cradle, using the locking bracket or locking rings to secure the cables to the cradle (*Installing the Cables and Connectors*, page 2).
- 17 Place the device and cradle into the cutout.
- 18 Secure the device to the mounting surface using the included screws.
- 19 Install the trim caps by snapping them in place around the edges of the device.

## Installing the Cables and Connectors

### Wiring to Power

- 1 Route the power cable from the mount to the boat battery or fuse block.
- 2 If necessary, extend the wires using 0.82 mm<sup>2</sup> (18 AWG) or larger wire.

- 3 Connect the red wire to the positive terminal on the battery or fuse block, and connect the black wire to the negative terminal.

### Power and Data Cable

- The wiring harness connects the device to power and NMEA® 0183 devices. 6-inch devices can also use these wires to share user data, such as waypoints and routes.
- If you are not connecting NMEA 0183 devices or another chartplotter to share data, disregard the blue and brown wires.
- The device has one internal NMEA 0183 port that is used to connect to NMEA 0183 compliant devices.
- If it is necessary to extend the power and ground wires, you must use 0.82 mm<sup>2</sup> (18 AWG) or larger wire.
- If it is necessary to extend the NMEA 0183 or alarm wires, you must use .33 mm<sup>2</sup> (22 AWG) wire.

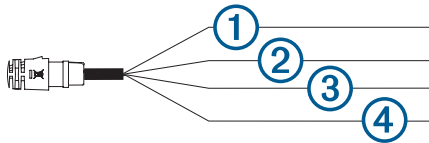

Item	Wire Function	Wire Color
①	NMEA 0183 internal port Rx (in)	Brown
②	NMEA 0183 internal port Tx (out)	Blue
③	Ground (power and NMEA 0183)	Black
④	Power	Red

### Connecting to a Garmin Device to Share User Data

**NOTE:** This feature is not available on ECHOMAP Plus 7x/9x devices. The blue and brown wires on those devices can connect to NMEA 0183 devices only.

You can connect the ECHOMAP Plus 6x device to a compatible Garmin device to share user data, such as waypoints. If the devices are mounted near each other, you can connect the blue and brown wires. If the devices are mounted too far apart for the wires to reach, you can connect the devices using a User Data Sharing Cable (010-12234-06).

- 1 Make sure both devices are connected to the same ground.
- 2 Complete an action:
  - If the devices are mounted near each other, connect the blue wire from the first device to the brown wire of the second, and connect the brown wire from the first device to the blue wire of the second.
  - If the devices are not mounted near each other, obtain a User Data Sharing Cable (010-12234-06), and connect the devices following the instructions included with the cable.
- 3 On both devices, select **Nav Info > Manage Data > User Data Sharing**.

User data is shared between the connected devices. If you select Clear User Data, data is removed from both connected devices.

### Connecting the Device to a Transducer

Go to [www.garmin.com/transducers](http://www.garmin.com/transducers) or contact your local Garmin dealer to determine the appropriate type of transducer for your needs.

- 1 Follow the instructions provided with your transducer to correctly install it on your boat.
- 2 Route the transducer cable to the back of your device, away from sources of electrical interference.
- 3 Connect the transducer cable to the appropriate port on the cradle.

### Connecting the Cables to the ECHOMAP Plus 6x Cradle

The connectors on the cables are keyed to fit only in the correct ports on the ECHOMAP Plus 6x cradle. The connected cables are held in place by a locking bracket.

- 1 Slide the cable locking bracket up from the bottom, and remove the bracket from the cradle.
- 2 Compare the divots ① on each cable connector to the keying on each port to determine which cable corresponds to each port.

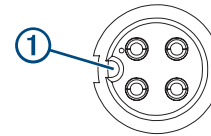

- 3 Fully and firmly insert each cable through a hole in the cradle, and securely connect each cable to a port.

**NOTE:** If the cables are not inserted far enough into the cradle, the connectors may not connect securely to the ports, and the device may appear to lose power or sonar or may stop working.

- 4 Place the locking bracket ② over the cables, and slide the bracket down to lock the cables in place.

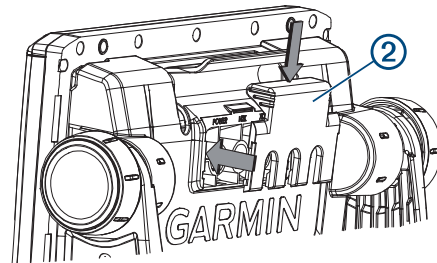

There is an audible click when the locking bracket is installed correctly.

### Connecting the Cables to the ECHOMAP Plus 7x/9x Cradle

The cables connectors fit only in the correct ports on the ECHOMAP Plus 7x/9x cradle. The connected cables are held in place by locking rings.

- 1 Insert each cable into the appropriate port in the cradle.
- 2 Spin the locking ring clockwise to lock the cable to the cradle.

### Installing the Device in the Cradle

After the cables are connected to the cradle, you can quickly place the device in the cradle.

- 1 Place the base of the device in the bottom of the cradle.
- 2 Tilt the top of the device toward the cradle until it fastens in place.

There is an audible click when the device is secured in the cradle.

#### NOTICE

You should make sure the device is firmly secured in the cradle. If the model uses a locking bracket, make sure the bracket is firmly snapped shut. There is an audible click when the device or locking bracket is installed correctly. If the device is not firmly secured, it can lose power. The device can also fall out of the cradle and become damaged if it is not firmly secured.

### Removing the Device from the Cradle

- 1 Press the release lever ① on the cradle until the device is released.

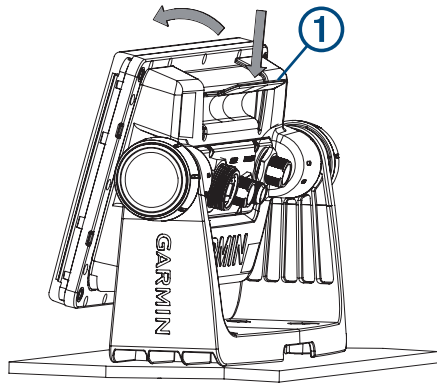

2 Tilt the device forward, and lift it out of the cradle.

## NMEA 2000® Considerations

### NOTICE

If you are connecting this device to an existing NMEA 2000 network, the NMEA 2000 network should already be connected to power. Do not connect the NMEA 2000 power cable to an existing NMEA 2000 network, because only one power source should be connected to a NMEA 2000 network.

If you are connecting this device to an existing NMEA 2000 network or engine network by another manufacturer, you should install a NMEA 2000 Power Isolator (010-11580-00) between the existing network and the Garmin devices.

If you are installing a NMEA 2000 power cable, you must connect it to the boat ignition switch or through another in-line switch. NMEA 2000 devices will drain your battery if the NMEA 2000 power cable is connected to the battery directly.

**NOTE:** NMEA 2000 is not available on all models.

NMEA 2000 compatible models can connect to a NMEA 2000 network on your boat to share data from NMEA 2000 compatible devices such as sensors or a VHF radio. The necessary NMEA 2000 cables and connectors are sold separately.

If you are unfamiliar with NMEA 2000, you should read the “NMEA 2000 Network Fundamentals” chapter of the *Technical Reference for NMEA 2000 Products*. To download this document, go to [www.garmin.com](http://www.garmin.com) and select Manuals on the product page for your device.

The port labeled NMEA 2000 on the cradle is used to connect it to a standard NMEA 2000 network.

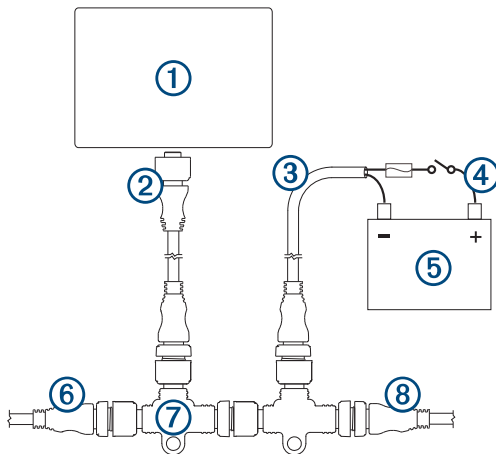

Item	Description
①	NMEA 2000 compatible Garmin device
②	NMEA 2000 drop cable

Item	Description
③	NMEA 2000 power cable
④	Ignition or in-line switch
⑤	12 Vdc power source
⑥	NMEA 2000 terminator or backbone cable
⑦	NMEA 2000 T-connector
⑧	NMEA 2000 terminator or backbone cable

## Specifications

### All Models

Material	Polycarbonate plastic
Water rating	IEC 60529 IPX7 <sup>1</sup>
Temperature range	From -15° to 55°C (from 5° to 131°F)
Input voltage	From 9 to 18 Vdc
Fuse	3 A, 125 V fast-acting
Compass-safe distance	65 cm (25.6 in.)
NMEA 2000 LEN @ 9 Vdc <sup>2</sup>	1
NMEA 2000 draw <sup>2</sup>	75 mA max.
Memory card	1 microSD® card slot; 32 GB max. card size

### 6-Inch Models

Dimensions (W x H x D)	21.8 x 13.0 x 6.2 cm (8.6 x 5.1 x 2.6 in.)
Display size (W x H)	13.7 x 7.7 cm (5.4 x 3.1 in.) 15.2 cm (6.2 in.) diagonal
Clearance to nearest obstruction	8 cm (3.1 in.)
Weight	0.75 kg (1.6 lb.)
Max. power draw at 10 Vdc	12 W
Typical current draw at 12 Vdc (RMS)	0.7 A
Max. current draw at 12 Vdc (RMS)	1.25 A
Wireless frequencies and protocols	2.4 GHz @ 17.2 dBm nominal

### 7-Inch Models

Dimensions (W x H x D)	25 x 13.9 x 5.1 cm ( 9.8 x 5.5 x 2.0 in.)
Display size (W x H)	15.5 x 8.6 cm (6.1 x 3.4 in.) 17.8 cm (7 in.) diagonal
Clearance to nearest obstruction	11.5 cm (4.5 in.)
Weight	0.77 kg (1.7 lb.)
Max. power draw at 10 Vdc	15 W, 9 W with a GT-52 transducer
Typical current draw at 12 Vdc (RMS)	0.8 A
Max. current draw at 12 Vdc (RMS) <sup>1</sup>	1.25 A
Wireless frequencies and protocols	2.4 GHz @ 18.5 dBm nominal

### 9-Inch Models

Dimensions (W x H x D)	11.4" x 6.5" x 2.4" (28.2 x 16.4 x 6.0 cm)
Display size (W x H)	19.9 x 11.3 cm (7.8 x 4.8 in.) 22.9 cm (9 in.) diagonal
Clearance to nearest obstruction	11.5 cm (4.5 in.)
Weight	1 kg (2.3 lb.)

<sup>1</sup> The device withstands incidental exposure to water of up to 1 m for up to 30 min. For more information, go to [www.garmin.com/waterrating](http://www.garmin.com/waterrating).

<sup>2</sup> NMEA 2000 is available on ECHOMAP Plus 7x/9x models.

Max. power draw at 10 Vdc	18 W
Typical current draw at 12 Vdc (RMS)	1 A
Max. current draw at 12 Vdc (RMS)	1.5 A
Wireless frequencies and protocols	2.4 GHz @ 18.5 dBm nominal

## NMEA 2000 PGN Information

### Transmit and Receive

PGN	Description
059392	ISO acknowledgment
059904	ISO request
060928	ISO address claim
126208	NMEA: Command, request, and acknowledge group function
126996	Product information
127250	Vessel heading
128259	Speed: Water referenced
128267	Water depth
129539	GNSS DOPs
129799	Radio frequency, mode, and power
130306	Wind data
130312	Temperature

### Transmit

PGN	Description
126464	Transmit and receive PGN list group function
127258	Magnetic Variance
129025	Position: Rapid update
129026	COG and SOG: Rapid update
129029	GNSS position data
129283	Cross track error
129284	Navigation data
129285	Navigation route and waypoint info
129540	GNSS satellites in view

### Receive

PGN	Description
127245	Rudder
127250	Vessel heading
127488	Engine parameters: Rapid update
127489	Engine parameters: Dynamic
127493	Transmission parameters: Dynamic
127498	Engine parameters: Static
127505	Fluid level
129038	AIS class A position report
129039	AIS class B position report
129040	AIS class B extended position report
129794	AIS class A static and voyage related data
129798	AIS SAR aircraft position report
128000	Nautical leeway angle
129802	AIS safety-related broadcast message
129808	DSC call information
130310	Environmental parameters
130311	Environmental parameters (obsolete)
130313	Humidity
130314	Actual pressure
130576	Small craft status

This data applies only to NMEA 2000-compatible products.

## NMEA 0183 Information

### Transmit

Sentence	Description
GPAPB	APB: Heading or track controller (autopilot) sentence "B"
GPBOD	BOD: Bearing (origin to destination)
GPBWC	BWC: Bearing and distance to waypoint
GPGGA	GGA: Global positioning system fix data
GPGLL	GLL: Geographic position (latitude and longitude)
GPGSA	GSA: GNSS DOP and active satellites
GPGSV	GSV: GNSS satellites in view
GPRMB	RMB: Recommended minimum navigation information
GPRMC	RMC: Recommended minimum specific GNSS data
GPRTTE	RTE: Routes
GPVTG	VTG: Course over ground and ground speed
GPWPL	WPL: Waypoint location
GPXTE	XTE: Cross track error
PGRME	E: Estimated error
PGRMM	M: Map datum
PGRMZ	Z: Altitude
SDDBT	DBT: Depth below transducer
SDDPT	DPT: Depth
SDMTW	MTW: Water temperature
SDVHW	VHW: Water speed and heading

### Receive

Sentence	Description
DPT	Depth
DBT	Depth below transducer
MTW	Water temperature
VHW	Water speed and heading
WPL	Waypoint location
DSC	Digital selective calling information
DSE	Expanded digital selective calling
HDG	Heading, deviation, and variation
HDM	Heading, magnetic
MWD	Wind direction and speed
MDA	Meteorological composite
MWV	Wind speed and angle
VDM	AIS VHF data-link message

You can purchase complete information about National Marine Electronics Association (NMEA) format and sentences from: NMEA, Seven Riggs Avenue, Severna Park, MD 21146 USA ([www.nmea.org](http://www.nmea.org))

© 2017 Garmin Ltd. or its subsidiaries

Garmin® and the Garmin logo are trademarks of Garmin Ltd. or its subsidiaries, registered in the USA and other countries. ActiveCaptain™, ECHOMAP™, Garmin ClearVü™, and Garmin Quickdraw™ are trademarks of Garmin Ltd. or its subsidiaries. These trademarks may not be used without the express permission of Garmin.

The Bluetooth® word mark and logos are owned by the Bluetooth SIG, Inc. and any use of such marks by Garmin is under license. NMEA®, NMEA 2000®, and the NMEA 2000 logo are registered trademarks of the National Marine Electronics Association. NMEA® is a registered trademark of the National Marine Electronics Association. microSD® and the microSD logo are trademarks of SD-3C, LLC. Wi-Fi® is a registered mark of Wi-Fi Alliance Corporation.

