

# Operation and Maintenance Manual

---

## **4006D-E23TA and 4008D-E30TA Industrial Engines**

---

DE6 (Engine)  
DE8 (Engine)



## Important Safety Information

Most accidents that involve product operation, maintenance and repair are caused by failure to observe basic safety rules or precautions. An accident can often be avoided by recognizing potentially hazardous situations before an accident occurs. A person must be alert to potential hazards. This person should also have the necessary training, skills and tools to perform these functions correctly.

**Incorrect operation, lubrication, maintenance or repair of this product can be dangerous and could result in injury or death.**

**Do not operate or perform any lubrication, maintenance or repair on this product, until you have read and understood the operation, lubrication, maintenance and repair information.**

Safety precautions and warnings are provided in this manual and on the product. If these hazard warnings are not heeded, bodily injury or death could occur to you or to other persons.

The hazards are identified by the "Safety Alert Symbol" and followed by a "Signal Word" such as "DANGER", "WARNING" or "CAUTION". The Safety Alert "WARNING" label is shown below.



The meaning of this safety alert symbol is as follows:

**Attention! Become Alert! Your Safety is Involved.**

The message that appears under the warning explains the hazard and can be either written or pictorially presented.

Operations that may cause product damage are identified by "NOTICE" labels on the product and in this publication.

**Perkins cannot anticipate every possible circumstance that might involve a potential hazard. The warnings in this publication and on the product are, therefore, not all inclusive. You must not use this product in any manner different from that considered by this manual without first satisfying yourself that you have considered all safety rules and precautions applicable to the operation of the product in the location of use, including site-specific rules and precautions applicable to the worksite. If a tool, procedure, work method or operating technique that is not specifically recommended by Perkins is used, you must satisfy yourself that it is safe for you and for others. You should also ensure that you are authorized to perform this work, and that the product will not be damaged or become unsafe by the operation, lubrication, maintenance or repair procedures that you intend to use.**

The information, specifications, and illustrations in this publication are on the basis of information that was available at the time that the publication was written. The specifications, torques, pressures, measurements, adjustments, illustrations, and other items can change at any time. These changes can affect the service that is given to the product. Obtain the complete and most current information before you start any job. Perkins dealers or Perkins distributors have the most current information available.



**When replacement parts are required for this product Perkins recommends using Perkins replacement parts.**

**Failure to heed this warning can lead to premature failures, product damage, personal injury or death.**

---

**In the United States, the maintenance, replacement, or repair of the emission control devices and systems may be performed by any repair establishment or individual of the owner's choosing.**

---

## Table of Contents

Foreword .....	4
----------------	---

### Safety Section

Safety Messages .....	6
-----------------------	---

Burn Prevention.....	9
----------------------	---

Fire Prevention and Explosion Prevention.....	10
---	----

Crushing Prevention and Cutting Prevention..	12
--	----

Mounting and Dismounting .....	13
--------------------------------	----

Before Starting Engine .....	13
------------------------------	----

Engine Starting.....	13
----------------------	----

Engine Stopping .....	13
-----------------------	----

Electrical System.....	14
------------------------	----

Engine Electronics.....	14
-------------------------	----

### Product Information Section

Model Views .....	15
-------------------	----

### Operation Section

Lifting and Storage .....	21
---------------------------	----

Features and Controls.....	25
----------------------------	----

Engine Diagnostics .....	32
--------------------------	----

Engine Starting.....	33
----------------------	----

Engine Operation .....	34
------------------------	----

Engine Stopping .....	35
-----------------------	----

Cold Weather Operation .....	36
------------------------------	----

### Maintenance Section

Refill Capacities.....	38
------------------------	----

Maintenance Recommendations .....	50
-----------------------------------	----

Maintenance Interval Schedule.....	51
------------------------------------	----

### Warranty Section

Warranty Information.....	82
---------------------------	----

### Index Section

Index.....	83
------------	----

## Foreword

### California Proposition 65 Warning

**Diesel engine exhaust and some of its constituents are known to the State of California to cause cancer, birth defects, and other reproductive harm.**



**WARNING – This product can expose you to chemicals including ethylene glycol, which is known to the State of California to cause birth defects or other reproductive harm. For more information go to:**

**[www.P65Warnings.ca.gov](http://www.P65Warnings.ca.gov)**

**Do not ingest this chemical. Wash hands after handling to avoid incidental ingestion.**



**WARNING – This product can expose you to chemicals including lead and lead compounds, which are known to the State of California to cause cancer, birth defects, or other reproductive harm. For more information go to:**

**[www.P65Warnings.ca.gov](http://www.P65Warnings.ca.gov)**

**Wash hands after handling components that may contain lead.**

### Literature Information

This manual contains safety, operation instructions, lubrication, and maintenance information. This manual should be stored in or near the engine area in a literature holder or literature storage area. Read, study, and keep the manual with the literature and engine information.

English is the primary language for all Perkins publications. The English used facilitates translation and consistency.

Some photographs or illustrations in this manual show details or attachments that may be different from your engine. Guards and covers may have been removed for illustrative purposes. Continuing improvement and advancement of product design may have caused changes to your engine which are not included in this manual. Whenever a question arises regarding your engine, or this manual, please consult with your Perkins dealer or your Perkins distributor for the latest available information.

### Safety

This safety section lists basic safety precautions. In addition, this section identifies hazardous, warning situations. Read and understand the basic precautions listed in the safety section before operating or performing lubrication, maintenance, and repair on this product.

### Operation

Operating techniques outlined in this manual are basic. The operating techniques assist with developing the skills and techniques required to operate the engine more efficiently and economically. Skill and techniques develop as the operator gains knowledge of the engine and the capabilities of the engine.

The operation section is a reference for operators. Photographs and illustrations guide the operator through procedures of inspecting, starting, operating, and stopping the engine. This section also includes a discussion of electronic diagnostic information.

### Maintenance

The maintenance section is a guide to engine care. The illustrated, step-by-step instructions are grouped by service hours and/or calendar time maintenance intervals. Items in the maintenance schedule are referenced to detailed instructions that follow.

Recommended service should be performed at the appropriate intervals as indicated in the Maintenance Interval Schedule. The actual operating environment of the engine also governs the Maintenance Interval Schedule. Therefore, under severe, dusty, wet, or freezing cold operating conditions, more frequent lubrication, and maintenance than is specified in the Maintenance Interval Schedule may be necessary.

---

The maintenance schedule items are organized for a preventive maintenance management program. If the preventive maintenance program is followed, a periodic tune-up is not required. The implementation of a preventive maintenance management program should minimize operating costs through cost avoidances resulting from reductions in unscheduled downtime and failures.

## **Maintenance Intervals**

Perform maintenance on items at multiples of the original requirement. Each level and/or individual items in each level should be shifted ahead or back depending upon your specific maintenance practices, operation, and application. Perkins recommends that the maintenance schedules be reproduced and displayed near the engine as a convenient reminder. Perkins also recommends that a maintenance record be maintained as part of the permanent record of the engine.

Your authorized Perkins dealer or your Perkins distributor can assist you in adjusting your maintenance schedule to meet the needs of your operating environment.

## **Overhaul**

Major engine overhaul details are not covered in the Operation and Maintenance Manual except for the interval and the maintenance items in that interval. Major repairs are best left to trained personnel or an authorized Perkins distributor or dealer. Your Perkins dealer or your Perkins distributor offers various options regarding overhaul programs. If you experience a major engine failure, there are also numerous after failure overhaul options available. Consult with your Perkins dealer or your Perkins distributor for information regarding these options.

## Safety Section

i07430978

### Safety Messages

There may be several specific warning signs on your engine. The exact location and a description of the warning signs are reviewed in this section. Become familiar with all warning signs.

Ensure that all the warning signs are legible. Clean the warning signs or replace the warning signs if the words cannot be read or if the illustrations are not visible. Use a cloth, water, and soap to clean the warning signs. Do not use solvents, gasoline, or other harsh chemicals. Solvents, gasoline, or harsh chemicals could loosen the adhesive that secures the warning signs. The warning signs that are loosened could drop off the engine.

Replace any warning sign that is damaged or missing. If a warning sign is attached to a part of the engine that is replaced, install a new warning sign on the replacement part. Your Perkins distributor can provide new warning signs.

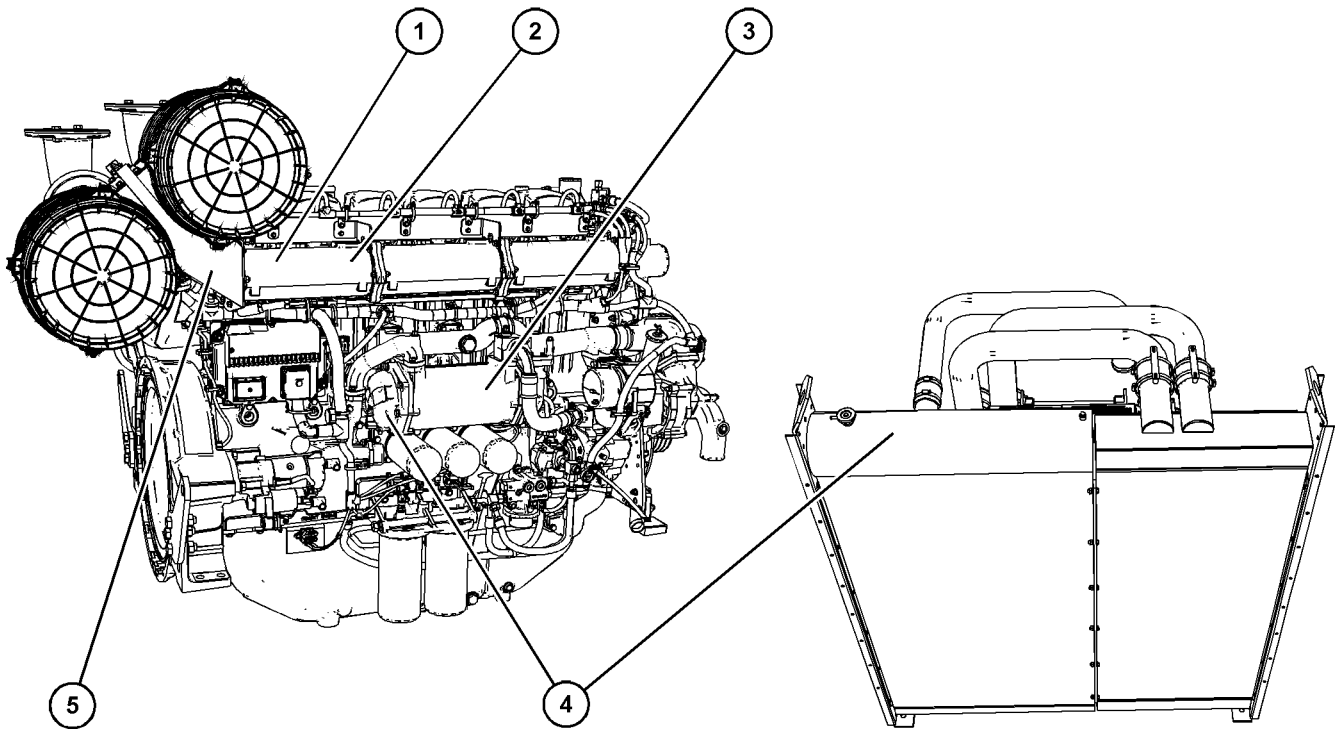

Illustration 1

g06321083

(1) Universal warning label locations  
(2) Do not step

(3) Hot surface label location  
(4) Hot fluid under pressure label locations

(5) Ether warning label location

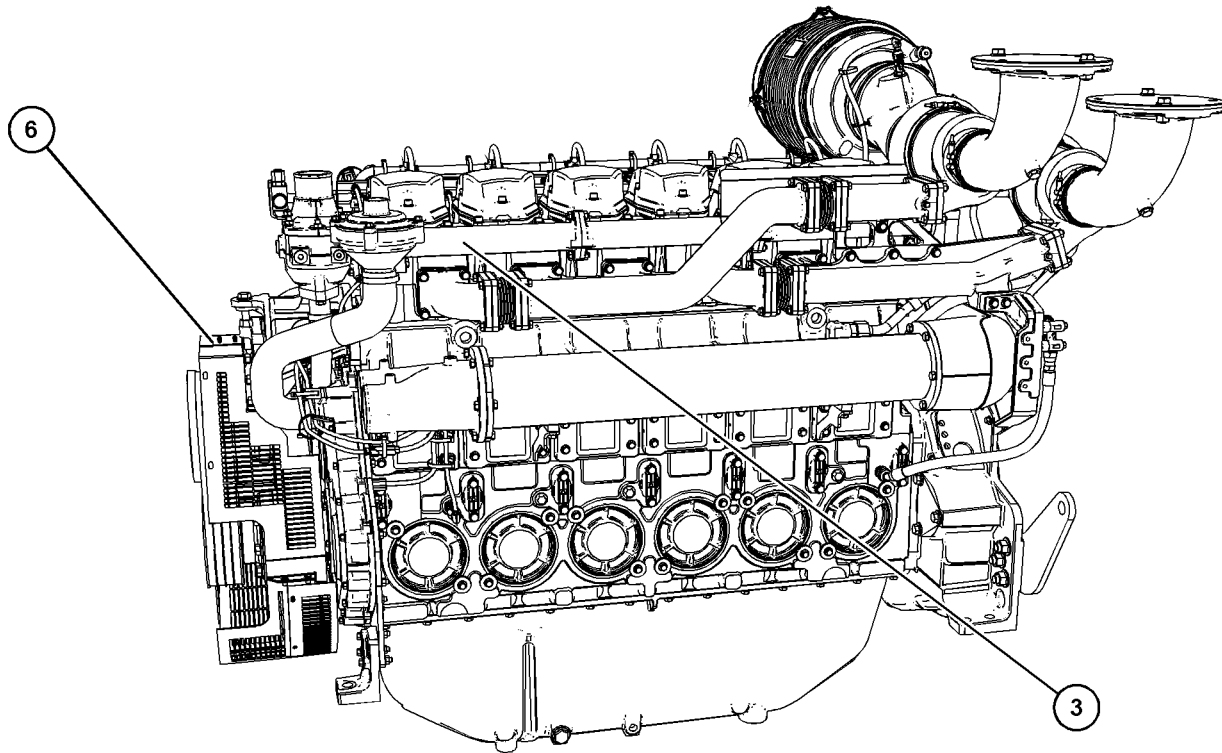

Illustration 2

g06321398

(3) Hot surface label location

(6) Rotating shaft hand crush hazard label location

## 1 Universal Warning

The universal warning label (1) is installed on the intake manifold.

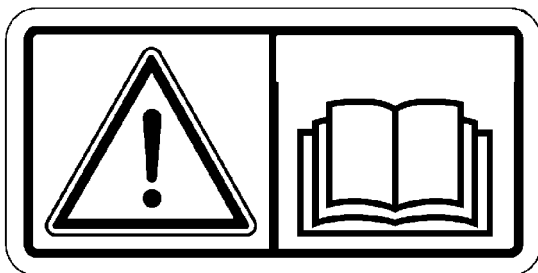

## 2 Do Not Step

The do not step safety message (2) is located on the intake manifold.

Illustration 3

g06019365

Universal Warning label



**Do not operate or work on this equipment unless you have read and understand the instructions and warnings in the Operation and Maintenance Manuals. Failure to follow the instructions or heed the warnings could result in serious injury or death.**

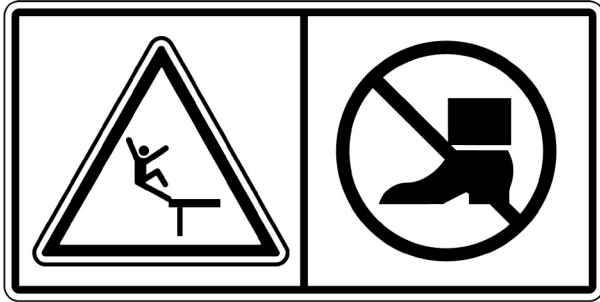

Illustration 4

g01393287

**⚠ WARNING**

Do not use this surface as a step or platform. This surface may not support additional weight or may be slippery. Serious injury or death could occur from a fall.

### 3 Hot Surface



Illustration 5

g01372256

**⚠ WARNING**

Hot parts or hot components can cause burns or personal injury. Do not allow hot parts or components to contact your skin. Use protective clothing or protective equipment to protect your skin.

The hot surface warning labels (3) are located in two locations. The oil cooler and heat shield of the coolant rail.

### 4 Hot Fluid Under Pressure



Illustration 6

g01371640

**⚠ WARNING**

Pressurized system! Hot coolant can cause serious burns, injury or death. To open the cooling system filler cap, stop the engine and wait until the cooling system components are cool. Loosen the cooling system pressure cap slowly in order to relieve the pressure. Read and understand the Operation and Maintenance Manual before performing any cooling system maintenance.



The hot fluids under pressure labels (4) have two positions. One label is on the end cover of the oil cooler. Perkins recommends that the other hot fluid under pressure label is installed on the radiator, next to the coolant filler cap.

## 5 Ether Warning



Illustration 7

g01372254

### **WARNING**

Do not use aerosol types of starting aids such as ether. Such use could result in an explosion and personal injury.

Either warning label (5) is on the support bracket for the air cleaners.

## 6 Rotating Shaft Hand Crush Hazard

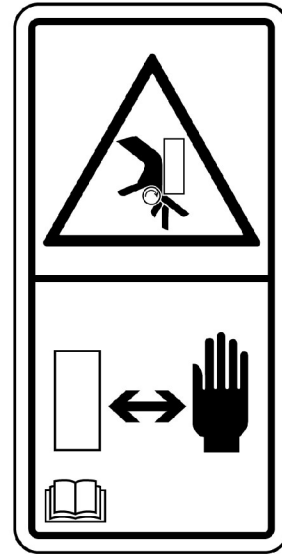

Illustration 8

g02781437

### **WARNING**

Rotating shaft pinch hazard. The shaft under this cover is rotating anytime the engine is running. Contact with a rotating shaft could cause injury or death. Keep hands away.

The rotating shaft hand crush hazard label (6) is on the cover of the crankshaft vibration damper.

i07390117

## Burn Prevention

### Coolant

When the engine is at operating temperature, the engine coolant is hot. The coolant is also under pressure. The radiator and all lines to the heaters or to the engine contain hot coolant. Any contact with hot coolant or with steam can cause severe burns. Allow cooling system components to cool before the cooling system is drained.

Check that the coolant level after the engine has stopped and the engine has been allowed to cool. Ensure that the filler cap is cool before removing the filler cap. The filler cap must be cool enough to touch with a bare hand. Remove the filler cap slowly to relieve pressure. Refer to this Operation and Maintenance Manual, Cooling System Coolant Level - Check for more information.

Cooling system conditioner contains alkali. Alkali can cause personal injury. Do not allow alkali to contact the skin, the eyes, or the mouth.

## Oils

Skin may be irritated following repeated or prolonged exposure to mineral and synthetic base oils. Refer to your suppliers Material Safety Data Sheets for detailed information. Hot oil and lubricating components can cause personal injury. Do not allow hot oil to contact the skin. Appropriate personal protective equipment should be used.

## Viton Seals

### WARNING

**If Viton is burned, a product of this burnt material is an acid which is hazardous. Do not allow burnt material to come into contact with the skin or with the eyes. Use the appropriate set of Personal Protective Equipment to protect your skin and eyes. Failure to follow the instructions or heed the warning could result in serious injury or death.**

If there is need to come into contact with components which have been burnt, ensure that the precautions which follow are used:

- Ensure that the components have cooled.
- Use Neoprene gloves and discard the gloves safely after use.
- Wash the area with calcium hydroxide solution and then with clean water.
- Disposal of components and gloves which are contaminated must be in accordance with local regulations.

If there is contamination of the skin or eyes, wash the affected area with a continuous supply of clean water or with calcium hydroxide solution. Wash the area effected for 15 to 60 minutes and obtain immediate medical attention.

## Diesel Fuel

Diesel may be irritating to the eyes, respiratory system, and skin. Prolonged exposure to diesel may cause various skin conditions. Appropriate personal protective equipment should be used. Refer to supplier Material safety Data sheets for detailed information.

## Batteries

The liquid in a battery is an electrolyte. Electrolyte is an acid that can cause personal injury. Do not allow electrolyte to contact the skin or the eyes.

Do not smoke whilst checking the battery electrolyte levels. Batteries give off flammable fumes which can explode.

Always wear protective glasses when you work with batteries. Wash hands after touching batteries. The use of gloves is recommended.

i06545894

## Fire Prevention and Explosion Prevention

---



Illustration 9

g00704000

All fuels, most lubricants, and some coolant mixtures are flammable.

Flammable fluids that are leaking or spilled onto hot surfaces or onto electrical components can cause a fire. Fire may cause personal injury and property damage.

After the emergency stop button is operated, ensure that you allow 15 minutes, before the engine covers are removed.

Determine whether the engine will be operated in an environment that allows combustible gases to be drawn into the air inlet system. These gases could cause the engine to overspeed. Personal injury, property damage, or engine damage could result.

If the application involves the presence of combustible gases, consult your Perkins dealer and/or your Perkins distributor for additional information about suitable protection devices.

Remove all flammable combustible materials or conductive materials such as fuel, oil, and debris from the engine. Do not allow any flammable combustible materials or conductive materials to accumulate on the engine.

Store fuels and lubricants in correctly marked containers away from unauthorized persons. Store oily rags and any flammable materials in protective containers. Do not smoke in areas that are used for storing flammable materials.

Do not expose the engine to any flame.

Exhaust shields (if equipped) protect hot exhaust components from oil or fuel spray if there was a line, a tube, or a seal failure. Exhaust shields must be installed correctly.

Do not carry out any work on the fuel lines or tanks that could ignite residual fuel. Grinding, welding, cutting, chiseling, and sawing have the potential to create a source of ignition must be avoided.

Do not weld on lines or tanks that contain flammable fluids. Do not flame cut lines or tanks that contain flammable fluid. Clean any such lines or tanks thoroughly with a nonflammable solvent prior to welding or flame cutting.

Wiring must be kept in good condition. Ensure that all electrical wires are correctly installed and securely attached. Check all electrical wires daily. Repair any wires that are loose or frayed before you operate the engine. Clean all electrical connections and tighten all electrical connections.

Eliminate all wiring that is unattached or unnecessary. Do not use any wires or cables that are smaller than the recommended gauge. Do not bypass any fuses and/or circuit breakers.

Arcing or sparking could cause a fire. Secure connections, recommended wiring, and correctly maintained battery cables will help to prevent arcing or sparking.

Ensure that the engine is stopped. Inspect all lines and hoses for wear damage, leakage or for deterioration. Ensure that the hoses are correctly routed. The lines and hoses must have adequate support and secure clamps.

Oil filters and fuel filters must be installed correctly. The filter housings must be tightened to the correct torque. Refer to the Disassembly and Assembly manual for more information.



Illustration 10

g00704059

Use caution when you are refueling an engine. Do not smoke whilst you are refueling an engine. Do not refuel an engine near open flames or sparks. Always stop the engine before refueling.

Avoid static electricity risk when fueling. Ultra-low Sulfur Diesel fuel (ULSD fuel) poses a greater static ignition hazard than earlier diesel formulations with a higher sulfur content. Avoid death or serious injury from fire or explosion. Consult your fuel or fuel system supplier to ensure that the delivery system is in compliance with fueling standards for proper grounding and bonding practices.

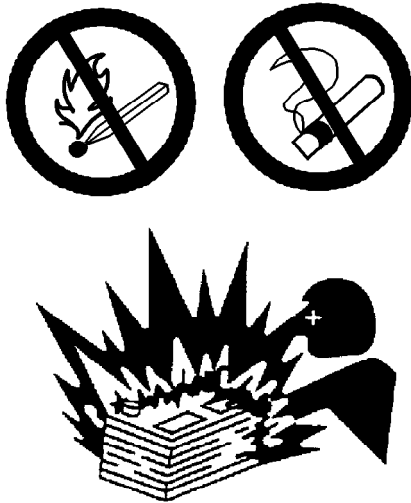

Illustration 11

g00704135

Gases from a battery can explode. Keep any open flames or sparks away from the top of a battery. Do not smoke in battery charging areas.

Never check the battery charge by placing a metal object across the terminal posts. Use a voltmeter or a hydrometer.

Incorrect jumper cable connections can cause an explosion that can result in injury. Refer to the Operation Section of this manual for specific instructions.

Do not charge a frozen battery. A frozen battery may cause an explosion.

The batteries must be kept clean. The covers (if equipped) must be kept on the cells. Use the recommended cables, connections, and battery box covers when the engine is operated.

## Fire Extinguisher

Make sure that a fire extinguisher is available. Be familiar with the operation of the fire extinguisher. Inspect the fire extinguisher and service the fire extinguisher regularly. Obey the recommendations on the instruction plate.

## Ether

Ether is flammable and poisonous.

Do not smoke whilst you are replacing an ether cylinder or whilst you are using an ether spray.

Do not store ether cylinders in living areas or in the engine compartment. Do not store ether cylinders in direct sunlight or in temperatures above 49° C (120° F). Keep ether cylinders away from open flames or sparks.

## Lines, Tubes, and Hoses

Do not bend high-pressure lines. Do not strike high-pressure lines. Do not install any lines that are damaged.

Leaks can cause fires. Consult your Perkins distributor for replacement parts.

Replace the parts if any of the following conditions are present:

- End fittings are damaged or leaking.
- Outer coverings are chafed or cut.
- Wires are exposed.
- Outer coverings are ballooning.
- Flexible parts of the hoses are kinked.
- Outer covers have embedded armoring.
- End fittings are displaced.

Make sure that all clamps, guards, and heat shields are installed correctly. During engine operation, correct installation will help to prevent vibration, rubbing against other parts, and excessive heat.

i02143194

## Crushing Prevention and Cutting Prevention

Support the component correctly when work beneath the component is performed.

Unless other maintenance instructions are provided, never attempt adjustments while the engine is running.

Stay clear of all rotating parts and of all moving parts. Leave the guards in place until maintenance is performed. After the maintenance is performed, reinstall the guards.

Keep objects away from moving fan blades. The fan blades will throw objects or cut objects.

When objects are struck, wear protective glasses in order to avoid injury to the eyes.

Chips or other debris may fly off objects when objects are struck. Before objects are struck, ensure that no one will be injured by flying debris.

i05875651

i06545901

## Mounting and Dismounting

Do not climb on the engine. The engine has not been designed with mounting or dismounting locations.

Refer to the OEM for the location of foot and hand holds for your specific application.

i04257031

## Before Starting Engine

### NOTICE

For initial start-up of a new or rebuilt engine, and for start-up of an engine that has been serviced, make provision to shut the engine off should an overspeed occur. This may be accomplished by shutting off the air and/or fuel supply to the engine.

### WARNING

**Engine exhaust contains products of combustion which may be harmful to your health. Always start and operate the engine in a well ventilated area and, if in an enclosed area, vent the exhaust to the outside.**

Inspect the engine for potential hazards.

Do not start the engine or move any of the controls if there is a "DO NOT OPERATE" warning tag or similar warning tag attached to the start switch or to the controls.

Before starting the engine, ensure that no one is on, underneath, or close to the engine. Ensure that the area is free of personnel.

If equipped, ensure that the lighting system for the engine is suitable for the conditions. Ensure that all lights work properly, if equipped.

All protective guards and all protective covers must be installed if the engine must be started in order to perform service procedures. To help prevent an accident that is caused by parts in rotation, work around the parts carefully.

Do not start an engine when the governor linkage is disconnected.

Do not bypass the automatic shutoff circuits. Do not disable the automatic shutoff circuits. The circuits are provided in order to help prevent personal injury. The circuits are also provided in order to help prevent engine damage.

## Engine Starting

### WARNING

**Do not use aerosol types of starting aids such as ether. Such use could result in an explosion and personal injury.**

If a warning tag is attached to the engine start switch, or to the controls DO NOT start the engine or move the controls. Consult with the person that attached the warning tag before the engine is started.

All protective guards and all protective covers must be installed if the engine must be started to perform service procedures.

Start the engine from the operators compartment or from the engine start switch.

Always start the engine according to the procedure that is described in the Operation and Maintenance Manual, "Engine Starting" topic in the Operation Section. Knowing the correct procedure will help to prevent major damage to the engine components. Knowing the procedure will also help to prevent personal injury.

Ensure that the jacket water heater (if equipped) is working correctly, check the water temperature reading on the control panel of the original engine manufacture.

Engine exhaust contains products of combustion which can be harmful to your health. Always start the engine and operate the engine in a well ventilated area. If the engine is started in an enclosed area, vent the engine exhaust to the outside.

**Note:** The engine may be equipped with a device for cold starting. If the engine will be operated in cold conditions, then an extra cold starting aid may be required. Normally, the engine will be equipped with the correct type of starting aid for your region of operation.

i07668288

## Engine Stopping

- Remove the load in increments.
- Open the circuit breaker.
- Allow the engine to run for five minutes to cool.
- Stop the engine.

Use the Emergency Stop Button (if equipped) ONLY in an emergency situation. Do not use the Emergency Stop Button for normal engine stopping. After an emergency stop, DO NOT start the engine until the problem that caused the emergency stop has been corrected.

Stop the engine if an overspeed condition occurs during the initial start-up of a new engine or an engine that has been overhauled. This may be accomplished by shutting off the fuel supply to the engine and/or shutting off the air supply to the engine.

To stop an electronically controlled engine, cut the power to the engine.

i06088340

## Electrical System

Never disconnect any charging unit circuit or battery circuit cable from the battery when the charging unit is operating. A spark can cause the combustible gases that are produced by some batteries to ignite.

To help prevent sparks from igniting combustible gases that are produced by some batteries, the negative “-” jump-start cable should be connected last from the external power source to the negative “-” terminal of the starting motor. If the starting motor is not equipped with a negative “-” terminal, connect the jump-start cable to the engine block.

Check the electrical wires daily for wires that are loose or frayed. Tighten all loose electrical wires before the engine is started. Repair all frayed electrical wires before the engine is started. Refer to the “Engine Starting” section of this Operation and Maintenance Manual for specific starting instructions.

## Grounding Practices

Proper grounding for the engine electrical system is necessary for optimum engine performance and reliability. Improper grounding will result in uncontrolled electrical circuit paths and in unreliable electrical circuit paths.

Uncontrolled electrical circuit paths can result in damage to main bearings, to crankshaft bearing journal surfaces, and to aluminum components.

Engines that are installed without engine-to-frame ground straps can be damaged by electrical discharge.

To ensure that the engine and the engine electrical systems function properly, an engine-to-frame ground strap with a direct path to the battery must be used. This path may be provided by way of a starting motor ground, a starting motor ground to the frame, or a direct engine ground to the frame.

All grounds should be tight and free of corrosion. The engine alternator must be grounded to the negative “-” battery terminal with a wire that is adequate to handle the full charging current of the alternator.

i07451988

## Engine Electronics

### WARNING

**Tampering with the electronic system installation or the OEM wiring installation can be dangerous and could result in personal injury or death and/or engine damage.**

This engine has a comprehensive, programmable Engine Monitoring System. The Engine Control Module (ECM) will monitor the engine operating conditions. If any of the engine parameters extend outside an allowable range, the ECM will initiate an immediate action.

The following actions are available for engine monitoring control: WARNING, DERATE, and SHUTDOWN. These engine monitoring modes can limit engine speed and/or the engine power.

Many of the parameters that are monitored by the ECM can be programmed for the engine monitoring functions. The following parameters can be monitored as a part of the Engine Monitoring System:

- Operating Altitude
- Engine Coolant Temperature
- Engine Oil Pressure
- Engine Speed
- Fuel Temperature
- Intake Manifold Air Temperature
- System Voltage

The Engine Monitoring package can vary for different engine models and different engine applications. However, the monitoring system and the engine monitoring control will be similar for all engines.

**Note:** Many of the engine control systems and display modules that are available for Perkins Engines will work in unison with the Engine Monitoring System. Together, the two controls will provide the engine monitoring function for the specific engine application. Refer to the Troubleshooting Manual for more information.

## Product Information Section

### Model Views

i07212245

### Model View Illustrations

The following model views show typical features of the engine. Due to individual applications, your engine may appear different from the illustrations.

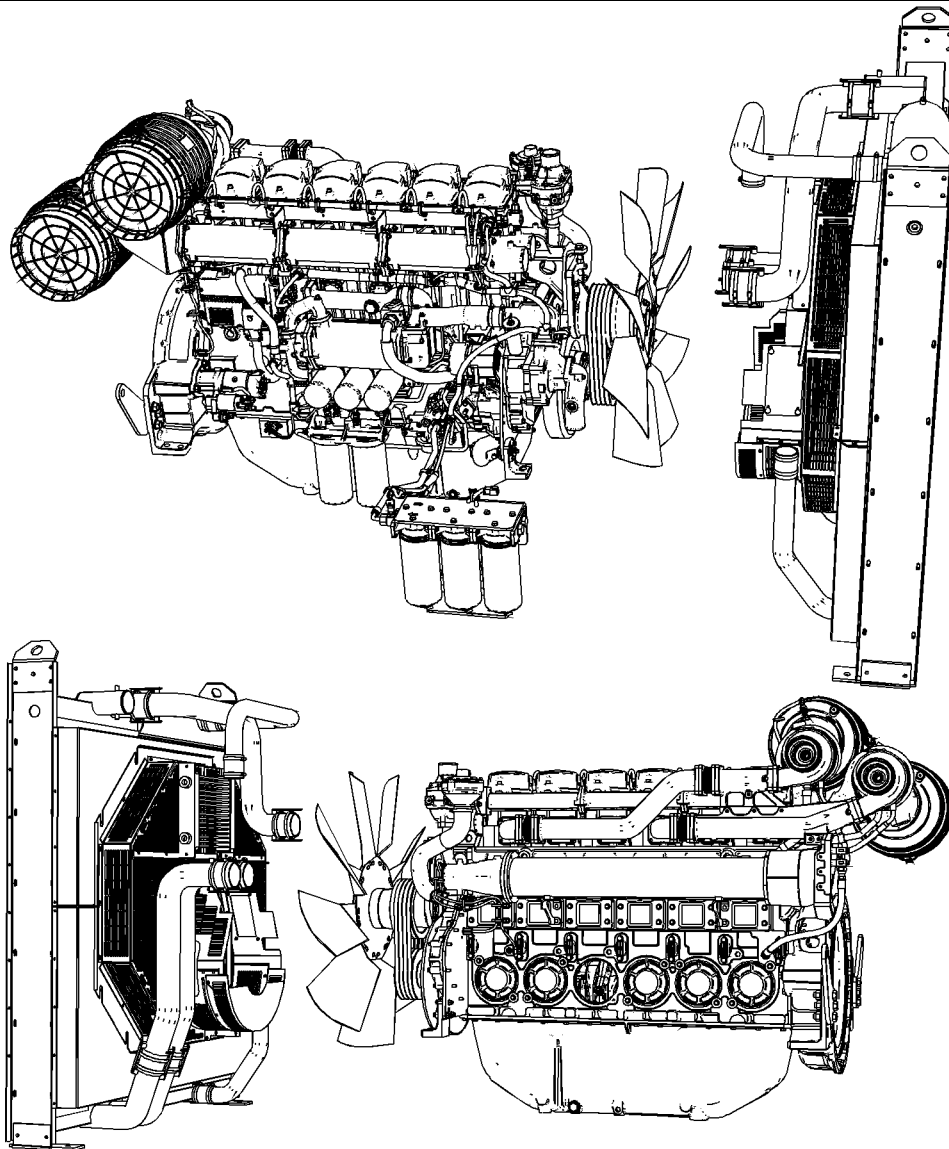

Illustration 12

Typical example of engine views and the radiator assembly

g06257338

## Engine Views

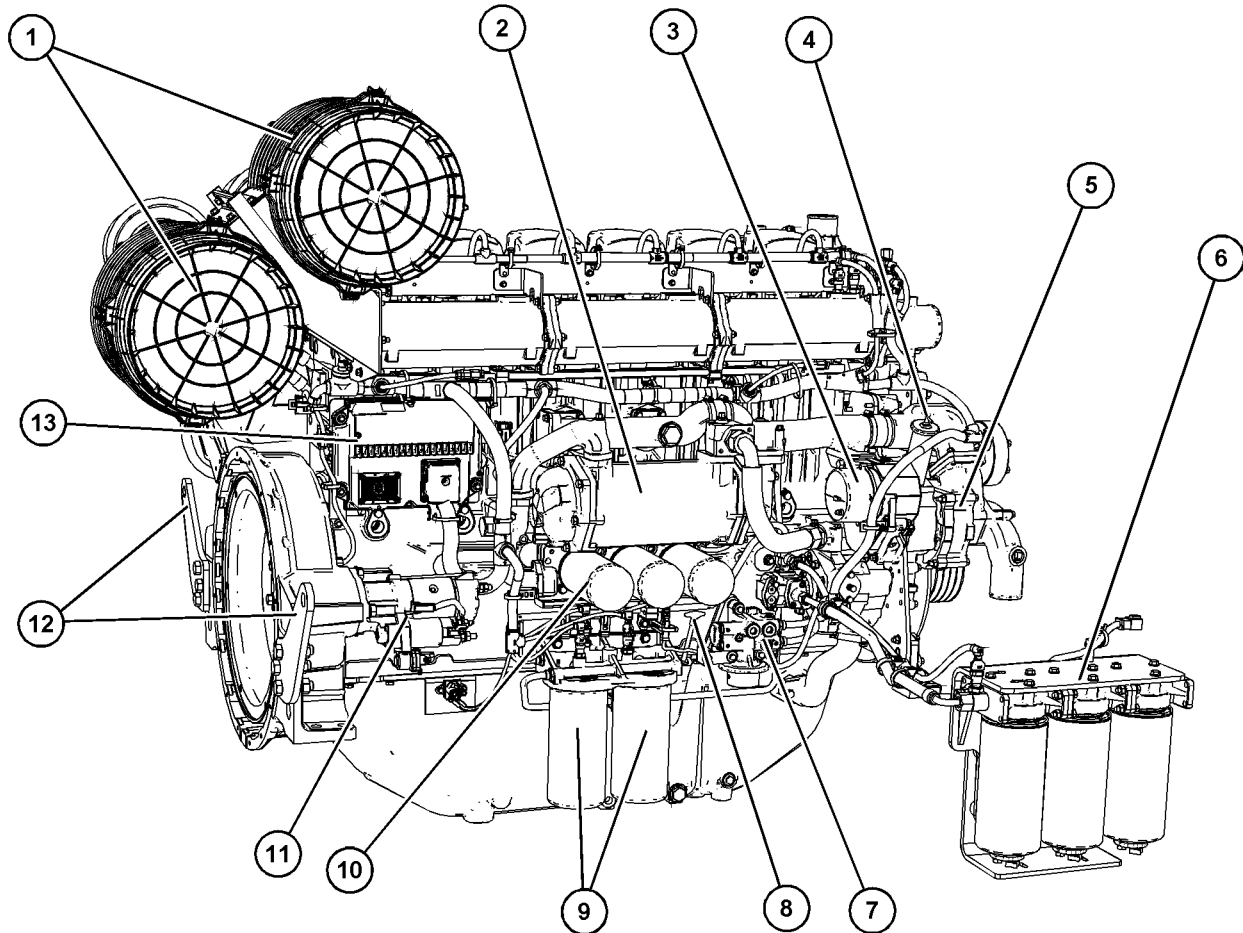

Illustration 13

g06257382

### Typical example

- |                       |                                       |                                |
|-----------------------|---------------------------------------|--------------------------------|
| (1) Twin air cleaners | (6) Module for 3 primary fuel filters | (11) Starting motor            |
| (2) Oil cooler        | (7) Electric priming pump             | (12) Rear lifting eyes         |
| (3) Alternator        | (8) Oil gauge (Dipstick)              | (13) Electronic control module |
| (4) Oil filler        | (9) Twin secondary fuel filters       |                                |
| (5) Coolant pump      | (10) Oil filters                      |                                |



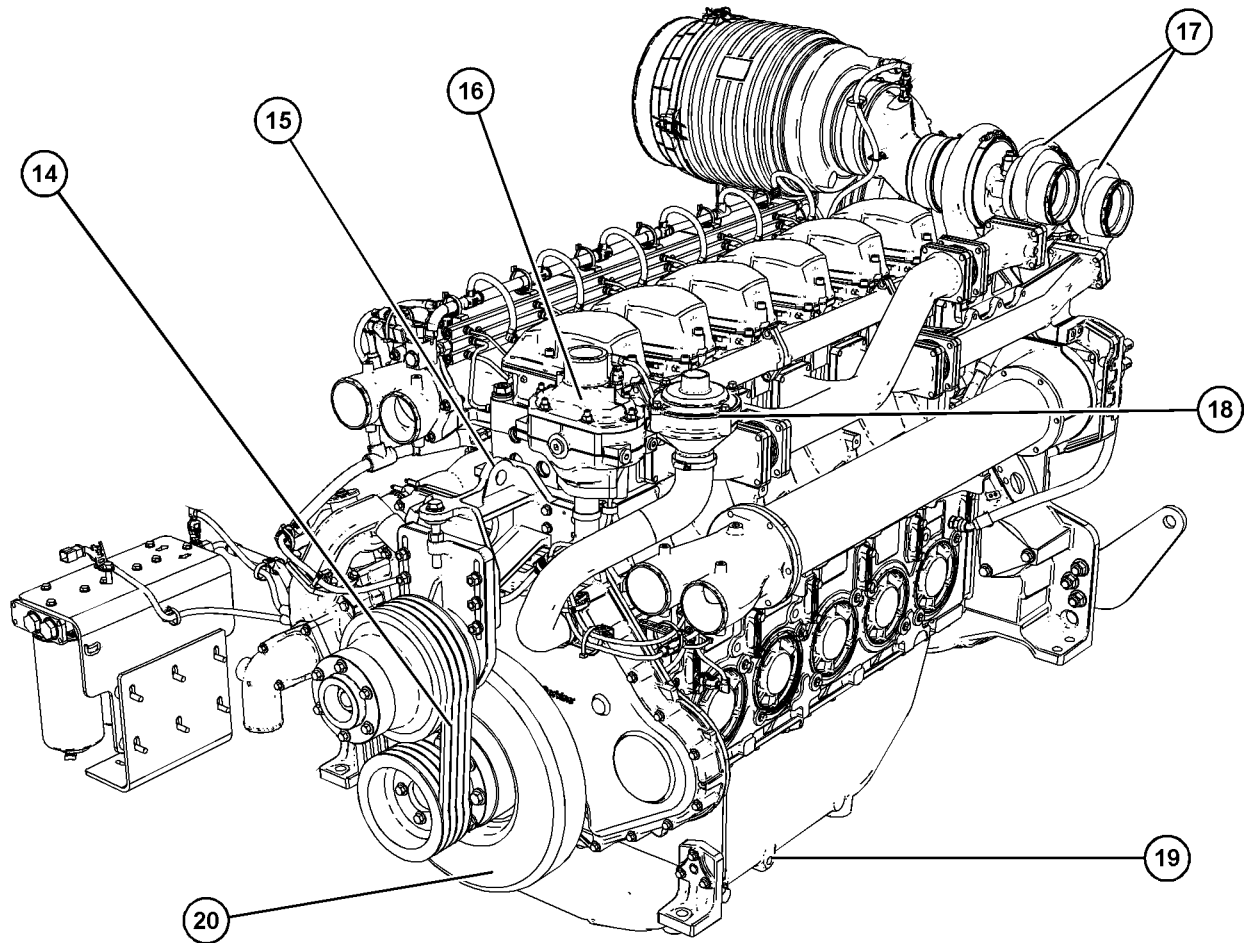

Illustration 14

g06257405

**Typical example**

- (14) Fan belts
- (15) Front lifting eye
- (16) Thermostat housing

- (17) Twin turbochargers
- (18) Breather
- (19) Oil drain plug

- (20) Crankshaft damper

## Radiator View

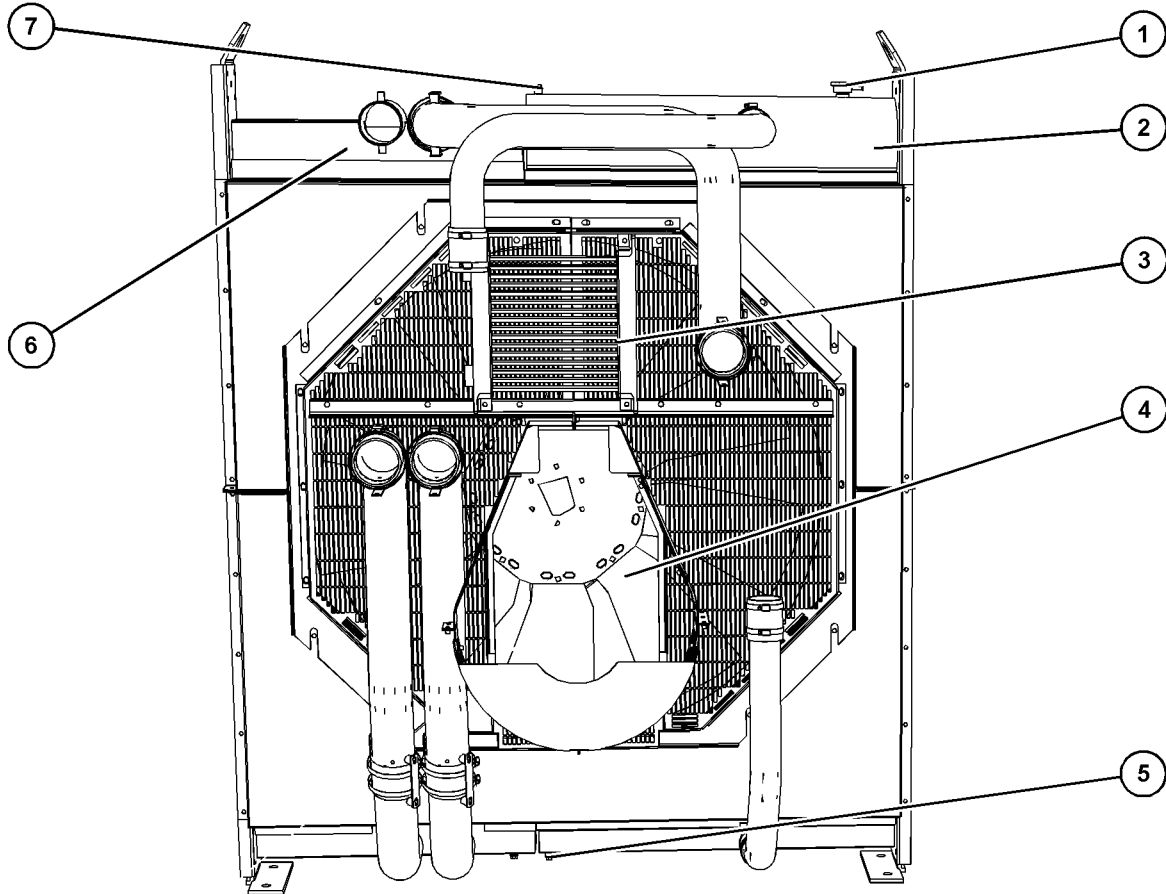

Illustration 15

g06257428

### Typical example

- |                  |                              |                  |
|------------------|------------------------------|------------------|
| (1) Radiator cap | (4) Fan                      | (7) Coolant vent |
| (2) Radiator     | (5) Coolant drain            |                  |
| (3) Fuel cooler  | (6) Air to air charge cooler |                  |

i08037396

## Engine Specifications

### Engine Description

The Perkins 4006D-E23TA and 4008D-E30TA Industrial Engine has the following characteristics:

- Four stroke cycle
- Mechanically actuated, electronically controlled fuel injection system
- Turbocharged
- Air to air charged cooled

**Note:** The front end of the engine is opposite the flywheel end of the engine. The left and the right sides of the engine are determined from the flywheel end. The number 1 cylinder is the front cylinder.

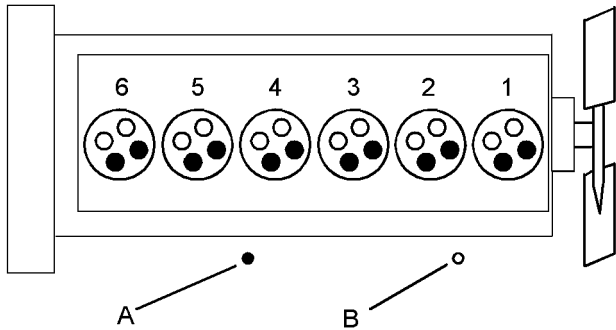

Illustration 16 g06253267

Typical example of a 6 cylinder engine

(A) Exhaust valves  
(B) Inlet valves

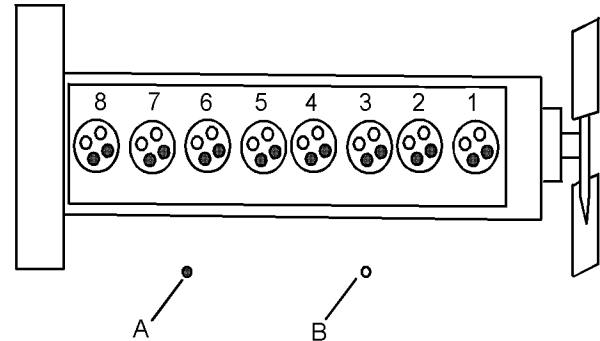

Illustration 17 g01207434

Typical example of an 8 cylinder engine

(A) Exhaust valves  
(B) Inlet valves

Table 1

Engine Specifications	
Engine	4006D-E23TA
Arrangement and Cylinders	In-Line 6 cylinder
Bore	160 mm (6.29920 inch)
Stroke	190 mm (7.48030 inch)
Displacement	22.921 L (1398.72514 cubic inch)
Compression Ratio	12.8:1
Firing Order	1-5-3-6-2-4
Aspiration	ATAAC <sup>(1)</sup>
Valve seat angle	20°
Valve lash	0.4 mm (0.01575 inch) Cold
Rotation (flywheel end)	Counterclockwise

(1) Air-to-air aftercooled

Table 2

Engine Specifications	
Engine	4008D-E30TA
Arrangement and cylinders	In-line 8 cylinder
Bore	160 mm (6.29920 inch)
Stroke	190 mm (7.48030 inch)
Displacement	30.56 L (1864.88549 cubic inch)
Compression Ratio	12.8:1
Firing order	1-4-7-6-8-5-2-3
Aspiration	ATAAC <sup>(1)</sup>
Valve seat angle	20°
Valve lash	0.4 mm (0.01575 inch) Cold
Rotation (flywheel end)	Counterclockwise

(1) Air-to-air aftercooled

## Electronic Engine Features

The engine is designed for electronic controls. The integral on board computer controls the operation of the engine. Current operating conditions are monitored. The Electronic Control Module (ECM) controls the response of the engine to these conditions and to the demands of the operator. These conditions and operator demands determine the precise control of fuel injection by the ECM. The electronic engine control system provides the following features:

- Engine speed governor
- Automatic air/fuel ratio control
- Torque rise shaping

- Injection timing control
- System diagnostics

### **Extra Features**

The following extra features provide increased engine fuel economy and serviceability:

- Cold starting capability
- Tampering detection
- Diagnostics

### **Engine Service Life**

Engine efficiency and maximum utilization of engine performance depend on the adherence to proper operation and maintenance recommendations. In addition, use recommended fuels, coolants, and lubricants. Use the Operation and Maintenance Manual as a guide for required engine maintenance.

Expected engine life is predicted by the average power that is demanded. The average power that is demanded is based on fuel consumption of the engine over a time. Reduced hours of operation at full throttle and/or operating at reduced throttle settings result in a lower average power demand. Reduced hours of operation will increase the length of operating time before an engine overhaul is required. For more information, refer to the Operation and Maintenance Manual, "Overhaul Considerations" topic.

### **Aftermarket Products and Perkins Engines**

Perkins does not warrant the quality or performance of non-Perkins fluids and filters.

When auxiliary devices, accessories, or consumables (filters, additives, catalysts) which are made by other manufacturers are used on Perkins products, the Perkins warranty is not affected simply because of such use.

**However, failures that result from the installation or use of other manufacturers devices, accessories, or consumables are NOT Perkins defects. Therefore, the defects are NOT covered under the Perkins warranty.**

## Operation Section

### Lifting and Storage

i03781209

#### Engine Storage

Refer to Perkins Engine Company Limited, Stafford, ST16 3UB for information on engine storage.

There are three different levels of engine storage. Level "A, B and C" .

##### Level "A "

Level "A" will give protection for 12 months for diesel engines and for gas engines. This level is used for engines that are transported in a container or by a truck.

##### Level "B "

This level is additional to level "A" . Level "B " will give protection under normal conditions of storage from -15° to +55°C (5° to 99°F) and "90%" relative humidity, for a maximum of 2 year.

##### Level "C "

This level is additional to level "B" . Level "C" will give protection for five years in tropical or in arctic climates. Level "C" also meets MOD NES 724 Level "J" for Europe, when engines are stored in an unheated building or in the open under a waterproof cover.

i07426649

#### Product Lifting

##### Engine Only

---

###### NOTICE

Always inspect lifting eyebolts and all other lifting equipment for damage before performing any lifting. Never bend the eyebolts and the brackets. Never perform product lifting if components are damaged.

---

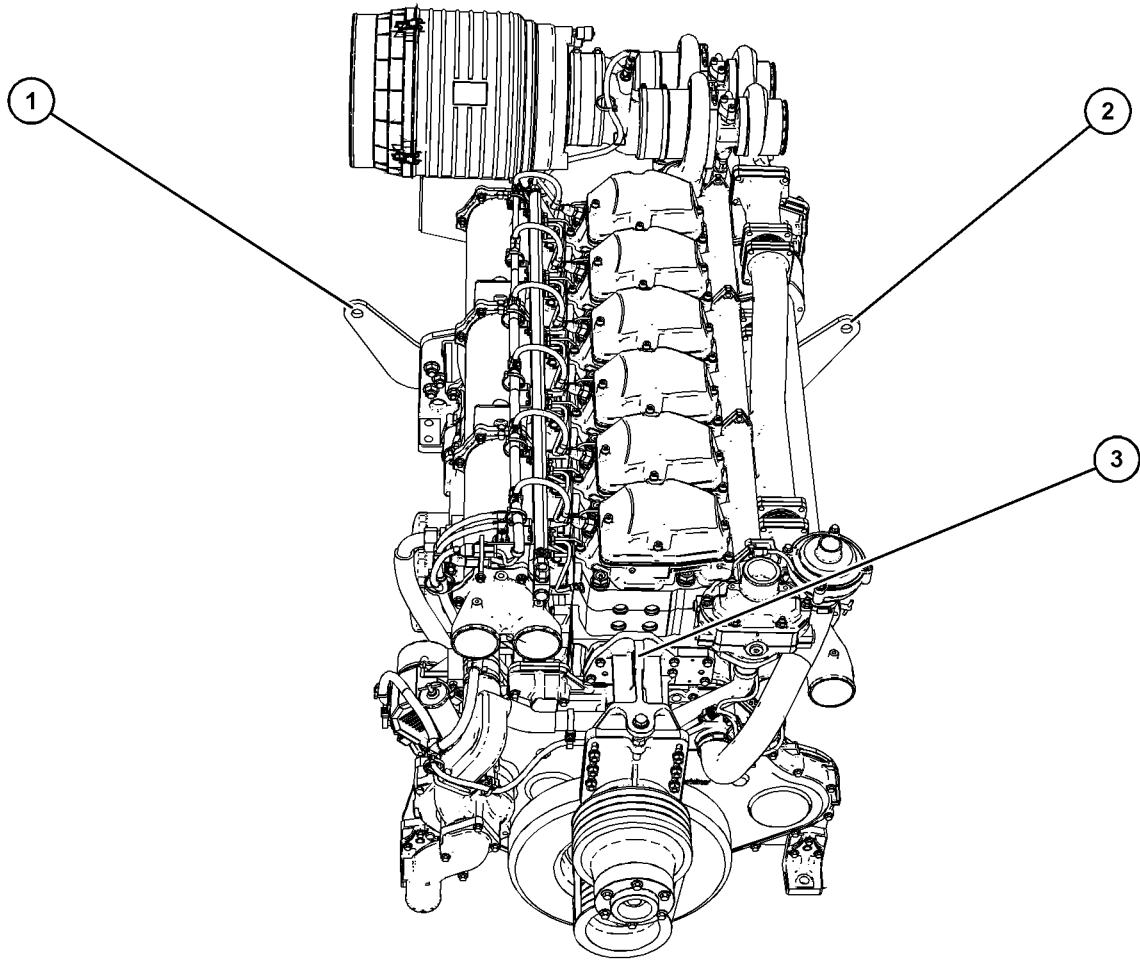

Illustration 18

Typical example of a 4006 engine

g06253337

(1) Rear lifting eye

(2) Rear lifting eye

(3) Front lifting eye

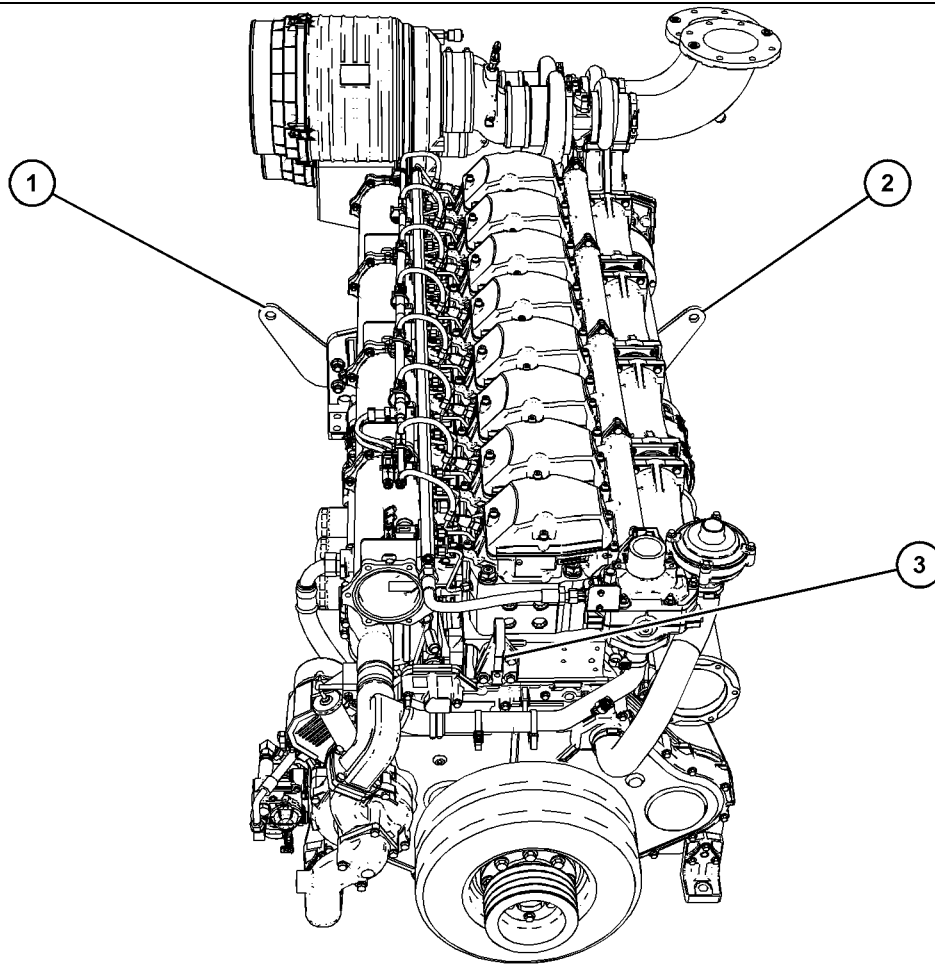

Illustration 19

g06325366

Typical example of a 4008 engine

(1) Rear lifting eye

(2) Rear lifting eye

(3) Front lifting eye

## Radiator Only

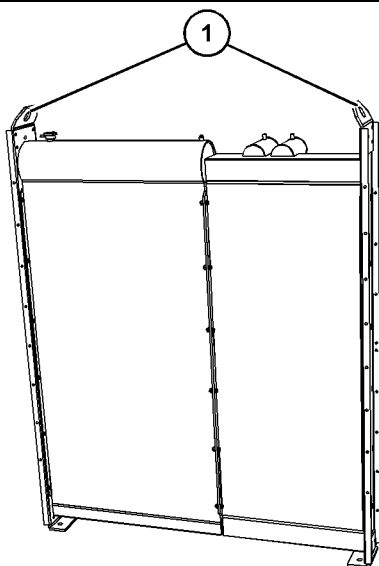

Illustration 20

g06253324

Typical example of a 4006 radiator

(1) Radiator lifting eyes

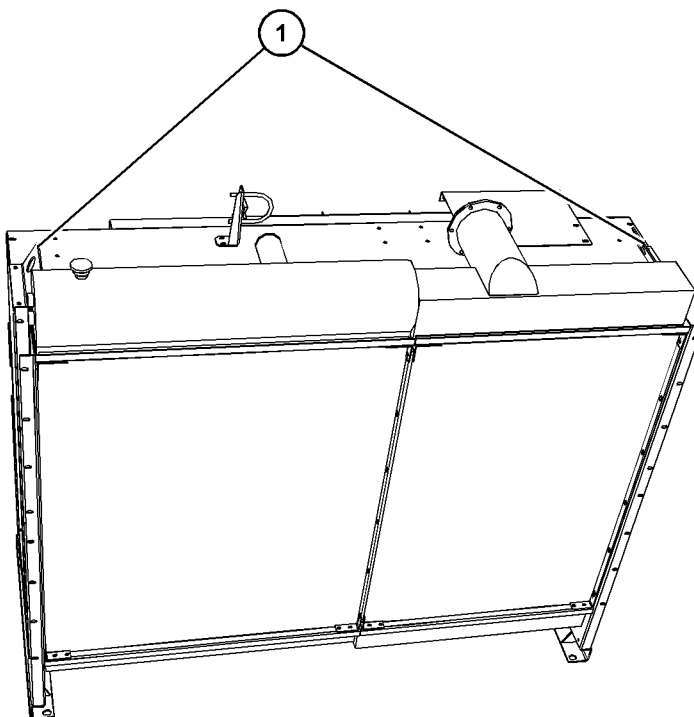

Illustration 21

g06325384

Typical example of a 4008 radiator

(1) Radiator lifting eyes



# Features and Controls

i06119742

## Monitoring System

The monitoring system is designed to alert the operator to an immediate problem.

The engine has protection in three stages:

- Warning
- Action Alert
- Shutdown

The engine protection may be overridden by the critical condition mode.

The Electronic Control Module (ECM) monitors the following parameters:

- Engine Temperatures
- Engine Pressures
- Engine Speed

If the parameters exceed a trip point for a period that is longer than the delay period, the ECM logs an event code. The indicator switches to the ON position.

The following parameters are monitored for event codes:

- Lubricating Oil Pressure
- Coolant Temperature
- Overspeed
- Intake Manifold Temperature
- Intake Manifold Pressure
- Fuel Temperature

The temperature protection is disabled for a period when the engine is cranking in order to compensate for heat soak solutions.

The ECM has dedicated alarm outputs for each of the three stages of protection. There are also dedicated alarm outputs for oil pressure, coolant temperature, and overspeed events which are energized at any stage of protection.

## Warning Alarm

The Warning alarm informs the user that the engine is approaching a critical condition.

If the engine is in the Warning condition, then the event will be logged in the memory of the ECM. An event code will be transmitted over the Perkins Data link and the hard wired Warning output will be energized. If the engine is in the Warning condition, the event code and output will remain while the condition exists. The electronic service tool is used to remove the event code from the memory of the ECM. The trip point for the Warning alarm will be set to a factory default in production. The electronic service tool may be used to alter the trip point for a Warning within predefined limits.

## Action Alert

The Action Alert informs the OEM that the engine is approaching a critical condition. The engine should be stopped in a controlled manner. Further running of the engine may result in an immediate shutdown.

If the engine is in the Action Alert condition, the event will be logged in the memory of the ECM. An event code will be transmitted over the Perkins Data link and the hard wired Action Alert will be energized. If the engine is in the Action Alert condition, the event code and output will remain while the condition exists. The event code cannot be cleared from the memory of the ECM without using a factory password.

## Shutdown

If the engine reaches the Shutdown condition, one of the following events has occurred: low lubricating oil pressure, high coolant temperature, or overspeed. The event will be logged in the memory of the ECM. The engine will be shut down. An event code will be transmitted over the Perkins Data link and the hard wired Shutdown output will be energized. The Shutdown condition will latch until the ECM is reset. The event code for the shutdown cannot be cleared from the memory of the ECM without using a factory password.

## Critical Protection Override

If the engine is in an application that is critical for safety, the protection system can be overridden in order to ensure the continuation of the power supply during engine fault conditions.

Critical Protection Override will be set by a switch input from the OEM. For example, switch to battery + in order to disable a critical override. Critical Protection Override input can be enabled in the electronic service tool by use of a factory password.

When the Critical Protection Override feature is active, the ECM will continue to run the engine in all shutdown conditions except for Overspeed shutdown. If the shutdown is overridden, an event code is generated. The ECM will log the event code. The ECM will energize the following: Warning, Action Alert, Shutdown, oil pressure, coolant temperature and overspeed outputs as normal. The warranty of the engine will be invalidated if the engine is operated in the following conditions: active event code and Critical Protection Override mode.

## Standard Warning Outputs

The ECM provides individual outputs in order to drive warning lamps or relays to indicate each of the following fault conditions:

- Diagnostic Fault
- Oil Pressure
- Coolant Temperature
- Overspeed
- Action Alert
- Warning
- Shutdown

If the ECM detects a warning for the coolant temperature, the output on the coolant temperature will be energized and the warning output will be energized. If the ECM detects a warning for the low oil pressure, the output on the oil pressure will be energized and the warning output will be energized.

If the Action Alert alarms are enabled and the ECM detects a coolant temperature condition, the output on the coolant Temperature will be energized and the output on the Action Alert will be energized.

If the engine shuts down on low oil pressure the output on the low oil pressure will be energized and the output on the shutdown will be energized. If the engine shuts down on coolant temperature, or the engine shuts down on overspeed the dedicated output and the shutdown output will be energized.

## Shutdown Reset

The cause of an engine shutdown must be investigated. Corrective action must be taken before the system is reset in order to operate the engine.

After an engine shutdown, operate the reset input of the ECM or power down the controller.

Powering down the electronic control module can be achieved by the operation of the keyswitch into sleep mode. The electronic control module can be powered down by isolating the power supply to the electronic control module.

**Note:** The ECM cannot be reset by using the Reset input until the engine has stopped.

## Diagnostic

If there is a fault with an engine protection sensor on the engine, the engine activates a diagnostic code. The engine communicates the diagnostic code to the operator via the Diagnostic output. The diagnostic code provides an indication to the operator of a fault with the engine protection system. Running of the engine for a prolonged period in this condition may result in engine failure. The output is generally used to drive lamps or relays.

The following sensors are monitored in order to determine if the sensors are out of the normal range, an open circuit, or a short circuit:

- Atmosphere Pressure
- Lubricating Oil Pressure
- Inlet Manifold Pressure
- Inlet Manifold Temperature
- Fuel Temperature
- Coolant Temperature
- Engine Speed
- Desired Speed Input

The Diagnostic output differs from the Warning and Shutdown outputs. The Warning and Shutdown outputs refer to the operation of the engine. The Diagnostic output refers to the condition of the electronic system and software system.

A diagnostic fault may develop on the lubricating oil pressure or coolant temperature sensors. For example, if a Shutdown protection sensor has a fault, this will result in an engine shutdown, unless the system is in critical protection override. If a diagnostic fault occurs, with one of the engine speed sensors while the engine is running. The engine continues to run by using the other timing sensor for reference.

i07212416

## **Sensors and Electrical Components (Sensors Only)**

The illustrations within the following sections are typical location of the sensors or electrical components for an industrial engine. Specific engines may appear different due to differences in applications. Some items have been removed from engine for clarity.

## Engine Sensor Views

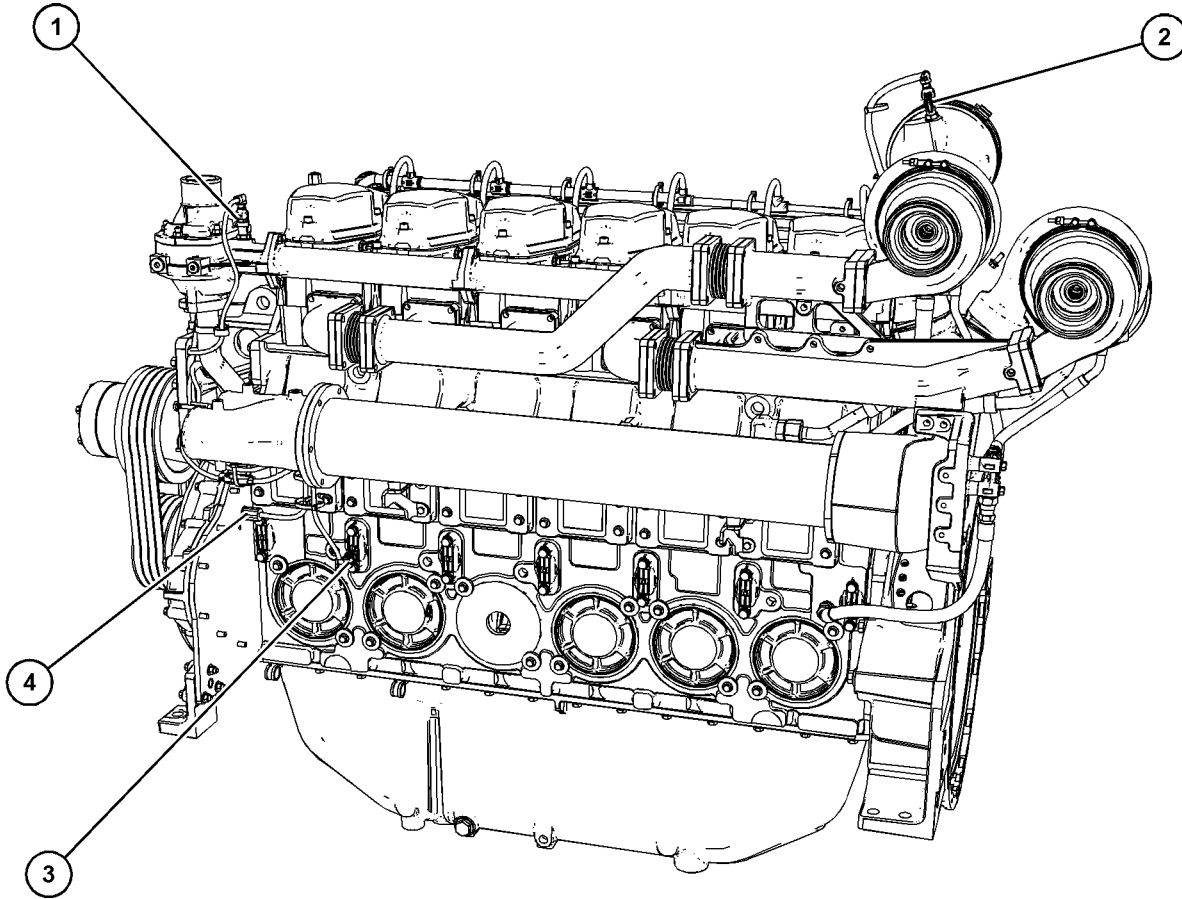

Illustration 22

g06256139

### Typical example

- (1) Coolant temperature sensor
- (2) Air inlet temperature sensor
- (3) Oil pressure sensor
- (4) Camshaft speed/timing sensor

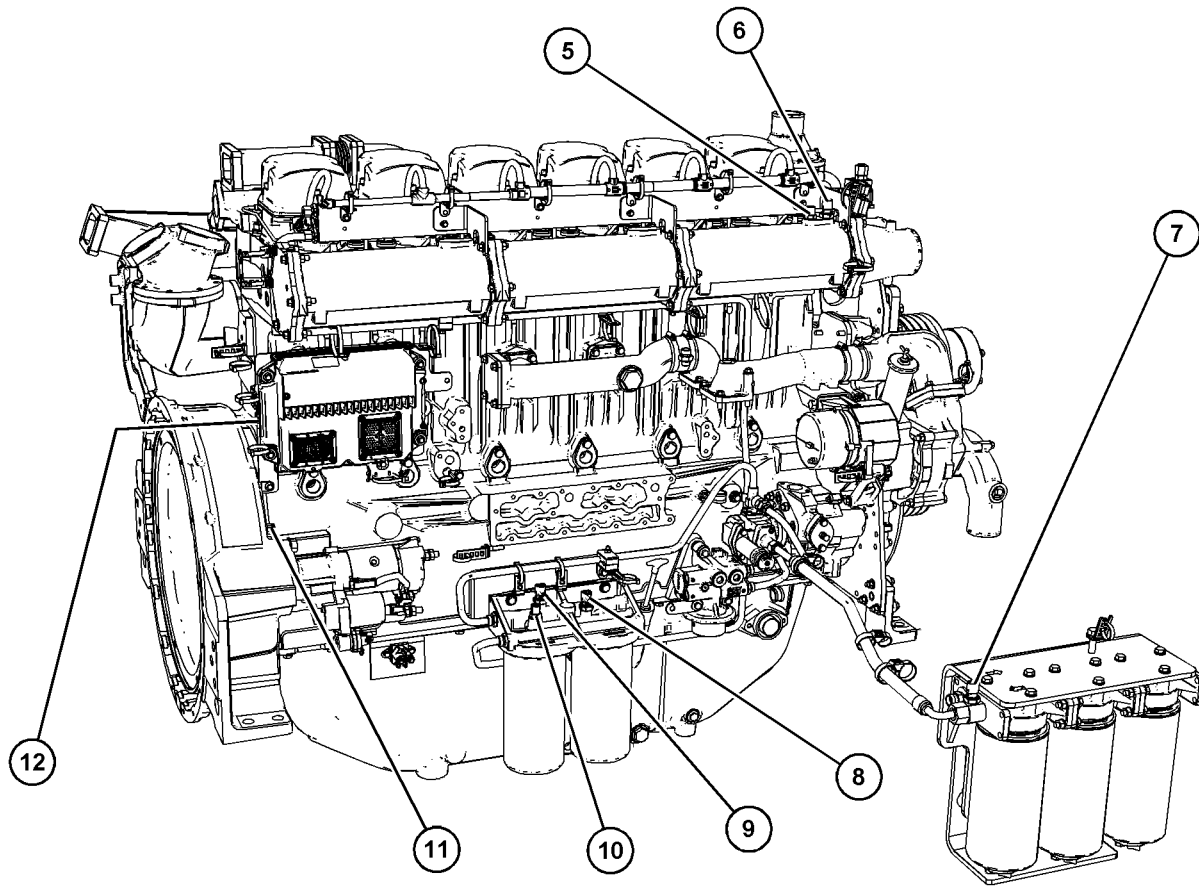

Illustration 23

g06256150

**Typical example**

- |   |   |  |
|---|---|--|
| (5) Inlet manifold temperature sensor               | (8) Fuel pressure sensor after secondary fuel filter  | (10) Fuel temperature sensor               |
| (6) Inlet manifold pressure sensor                  | (9) Fuel pressure sensor before secondary fuel filter | (11) Flywheel speed/timing sensor          |
| (7) Fuel pressure sensor after primary fuel filters |   | (12) Barometer pressure sensor (not shown) |

## Barometric Pressure Sensor

---

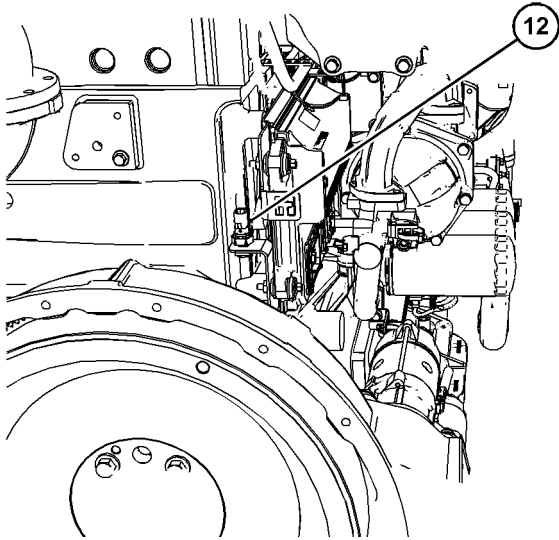

---

Illustration 24

g06256949

(12) Barometric pressure sensor

i07218875

## Sensors and Electrical Components (Electrical Components)

The engine view shown is a typical examples only.

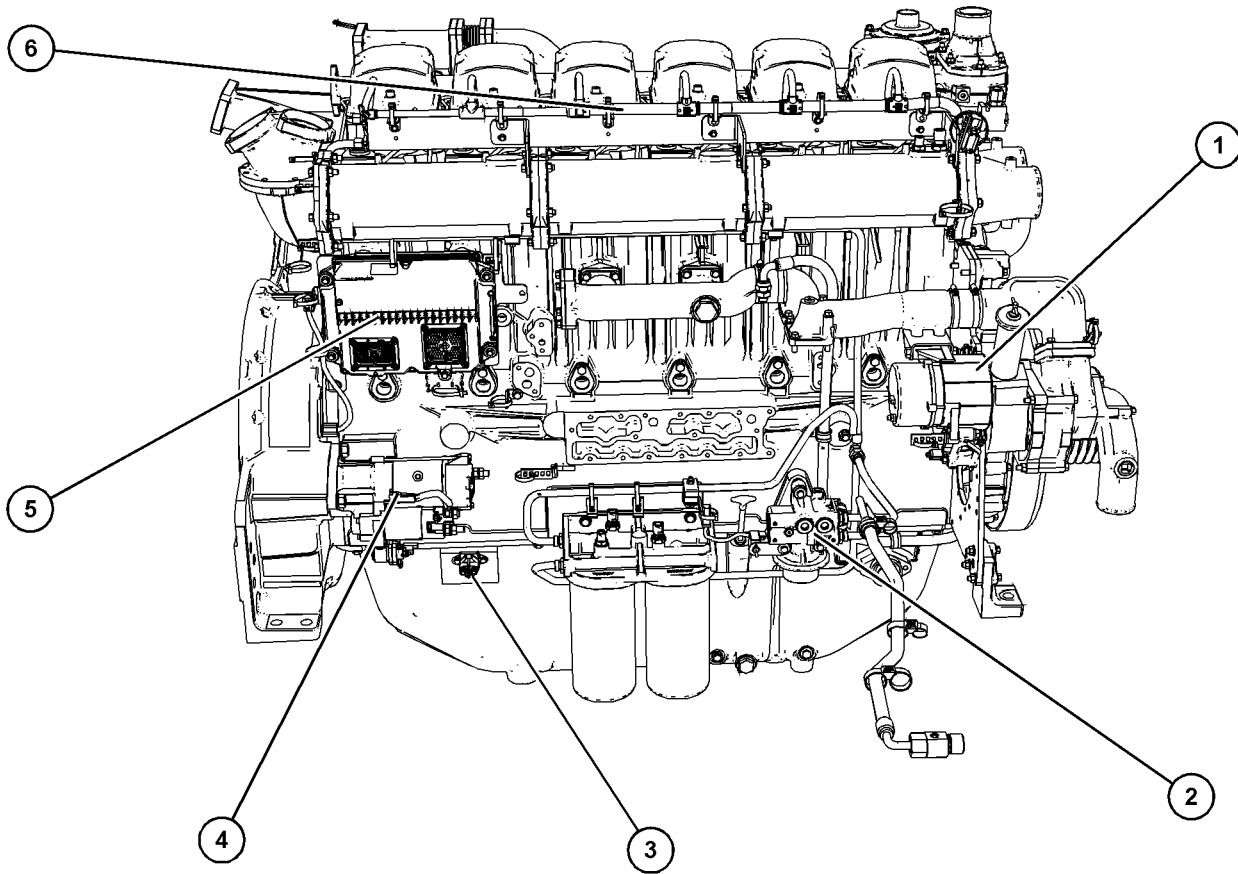

Illustration 25

g06256232

Typical example

- |  |                    |                                     |
|--|--------------------|-------------------------------------|
| (1) Alternator                           | (3) Starter relay  | (5) Electronic Control Module (ECM) |
| (2) Fuel priming pump with remote switch | (4) Starting motor | (6) Injector wiring harness         |

# Engine Diagnostics

i01797063

i05194988

## Self-Diagnostics

Perkins Electronic Engines have the capability to perform a self-diagnostics test. When the system detects an active problem, a diagnostic lamp is activated. Diagnostic codes will be stored in permanent memory in the Electronic Control Module (ECM). The diagnostic codes can be retrieved by using Perkins electronic service tools.

Some installations have electronic displays that provide direct readouts of the engine diagnostic codes. Refer to the manual that is provided by the OEM for more information on retrieving engine diagnostic codes.

Active codes represent problems that currently exist. These problems should be investigated first.

Logged codes represent the following items:

- Intermittent problems
- Recorded events
- Performance history

The problems may have been repaired since the logging of the code. These codes do not indicate that a repair is needed. The codes are guides or signals when a situation exists. Codes may be helpful to troubleshoot problems.

When the problems have been corrected, the corresponding logged fault codes should be cleared.

i01902949

## Fault Logging

The system provides the capability of Fault Logging. When the Electronic Control Module (ECM) generates an active diagnostic code, the code will be logged in the memory of the ECM. The codes that have been logged by the ECM can be identified by the electronic service tool. The active codes that have been logged will be cleared when the fault has been rectified or the fault is no longer active. The following logged faults can not be cleared from the memory of the ECM without using a factory password: Overspeed, low engine oil pressure and high engine coolant temperature.

## Engine Operation with Intermittent Diagnostic Codes

If a diagnostic lamp illuminates during normal engine operation and the diagnostic lamp shuts off, an intermittent fault may have occurred. If a fault has occurred, the fault will be logged into the memory of the Electronic Control Module (ECM).

In most cases, it is not necessary to stop the engine because of an intermittent code. However, the operator should retrieve the logged fault codes and the operator should reference the appropriate information in order to identify the nature of the event. The operator should log any observation that could have caused the lamp to light.

- Low power
- Limits of the engine speed
- Excessive smoke, etc

This information can be useful to help troubleshoot the situation. The information can also be used for future reference. For more information on diagnostic codes, refer to the Troubleshooting Guide for this engine.

i06225055

## Configuration Parameters

The engine electronic control module (ECM) has two types of configuration parameters. The system configuration parameters and the customer specified parameters.

The electronic service tool is required in order to alter the configuration parameters.

## System Configuration Parameters

System configuration parameters affect the emissions of the engine or the power of the engine. System configuration parameters are programmed at the factory. Normally, system configuration parameters would never require changing through the life of the engine. System configuration parameters must be reprogrammed if an ECM is replaced. System configuration parameters do not require reprogrammed if the ECM software is changed. Factory passwords are required to change these parameters.

For more information on system configuration parameters and customer specified parameters, refer to Troubleshooting manual.



# Engine Starting

i02415223

## Cold Weather Starting

 **WARNING**

**Do not use aerosol types of starting aids such as ether. Such use could result in an explosion and personal injury.**

---

Startability will be improved at temperatures below +10 °C (+50 °F) from the use of a jacket water heater or extra battery capacity.

## Engine Operation

i07426332

### Engine Operation

Correct operation and maintenance are key factors in obtaining the maximum life and economy of the engine. If the directions in the Operation and Maintenance Manual are followed, costs can be minimized and engine service life can be maximized.

The operation of the engine at no load or light load should be avoided or reduced to a minimum period.

Gauge readings (if equipped) should be observed and the data should be recorded frequently while the engine is operating. Comparing the data over time will help to determine normal readings for each gauge. Comparing data over time will also help detect abnormal operating developments. Significant changes in the readings should be investigated.

i02415226

### Fuel Conservation Practices

The efficiency of the engine can affect the fuel economy. Perkins design and technology in manufacturing provides maximum fuel efficiency in all applications. Follow the recommended procedures in order to attain optimum performance for the life of the engine.

- Ensure that the driven equipment is in good working order.
  - Cold engines consume excess fuel. Utilize heat from the jacket water system and the exhaust system, when possible. Keep cooling system components clean and keep cooling system components in good repair. Never operate the engine without water temperature regulators. All of these items will help maintain operating temperatures.
- Avoid spilling fuel. Fuel expands when the fuel is warmed up. The fuel may overflow from the fuel tank. Inspect fuel lines for leaks. Repair the fuel lines, as needed.
  - Be aware of the properties of the different fuels. Use only the recommended fuels.
  - Avoid unnecessary running at a low load. If the engine is not under load, the engine should be shut down.
  - Observe the air cleaner service indicator frequently. The air cleaner elements should be replaced when the air cleaner elements are dirty.
  - Maintain the electrical systems. One damaged battery cell will overwork the alternator. This will consume excess power and excess fuel.
  - Ensure that the drive belts are correctly adjusted. The drive belts should be in good condition.
  - Ensure that all of the connections of the hoses are tight. The connections should not leak.

## Engine Stopping

i02415227

### Stopping the Engine

**Note:** Individual applications will have different control systems. Ensure that the shutoff procedures are understood. Use the following general guidelines in order to stop the engine.

1. Remove the load from the engine. Allow the engine to run off load for five minutes in order to cool the engine.
2. Stop the engine after the cool down period according to the shutoff system on the engine and turn the ignition key switch to the OFF position. If necessary, refer to the instructions that are provided by the OEM.

i07425827

### Emergency Stopping

#### NOTICE

Emergency shutoff controls are for EMERGENCY use ONLY. DO NOT use emergency shutoff devices or controls for normal stopping procedure.

The engine should be equipped with an emergency stop button. For more information about the emergency stop button, refer to the OEM information.

Ensure that any components for the external system that support the engine operation are secured after the engine is stopped.

i02415231

### After Stopping Engine

**Note:** Before you check the engine oil, do not operate the engine for at least 10 minutes in order to allow the engine oil to return to the oil pan.

- If the engine is equipped with a service hour meter, note the reading. Perform the maintenance that is in the Operation and Maintenance Manual, "Maintenance Interval Schedule".
- Check the crankcase oil level. Maintain the oil level between the "MIN" mark and the "MAX" mark on the engine oil level gauge.

- If necessary, perform minor adjustments. Repair any leaks from the low pressure fuel system and from the cooling, lubrication or air systems.
- Fill the fuel tank in order to help prevent accumulation of moisture in the fuel. Do not overfill the fuel tank.

#### NOTICE

Only use antifreeze/coolant mixtures recommended in this Operation and Maintenance Manual, "Refill Capacities and Recommendations" topic or in this Operation and Maintenance Manual, "Fluid Recommendations" topic. Failure to do so can cause engine damage.

#### WARNING

**Pressurized System: Hot coolant can cause serious burns. To open the cooling system filler cap, stop the engine and wait until the cooling system components are cool. Loosen the cooling system pressure cap slowly in order to relieve the pressure.**

- Allow the engine to cool. Check the coolant level.
- Check the coolant for correct antifreeze protection and the correct corrosion protection. Add the correct coolant/water mixture, if necessary.
- Perform all required periodic maintenance on all driven equipment. This maintenance is outlined in the instructions from the OEM.

## Cold Weather Operation

i07818744

### Fuel and the Effect from Cold Weather

**Note:** Only use grades of fuel that are recommended by Perkins. Refer to this Operation and Maintenance Manual, “Fluid Recommendations”.

Properties of the diesel fuel can have a significant effect on the engine cold start capability. It is critical that the low temperature properties of diesel fuel are acceptable for the minimum ambient temperature the engine is expected to see in operation.

Following properties are used to define fuels low temperature capability:

- Cloud point
- Pour point
- Cold Filter Plugging Point (CFPP)

The cloud point of the fuel is the temperature at which waxes naturally found in the diesel fuel begin to form crystals. The cloud point of the fuel must be below lowest ambient temperature to prevent filters from plugging.

Pour point is the last temperature before the fuel flow stops and waxing of the fuel will start.

Cold Filter Plugging Point (CFPP) is a temperature at which a particular fuel will pass through a standardized filtration device. This CFPP gives an estimate of the lower operability temperature of fuel

Be aware of these properties when diesel fuel is purchased. Consider the average ambient air temperature for the engines application. Engines that are fueled in one climate may not operate well if the engines are shipped to colder climate. Problems can result due to changes in temperature.

Before troubleshooting for low power or for poor performance in the winter, check the fuel for waxing

The following components can provide a means of minimizing fuel waxing problems in cold weather:

- Fuel heaters, which may be an OEM option
- Fuel line insulation, which may be an OEM option

Winter and arctic grades of diesel fuel are available in the countries and territories with severe winters. For more information refer to the Operation and Maintenance Manual, “Fuel For Cold-Weather Operation”

Another important fuel property which can affect cold start and operation of diesel engine is Cetane number. Detail and requirements of this property are given in this Operation and Maintenance Manual, “Fluid Recommendations”.

i06093465

### Fuel Related Components in Cold Weather

#### Fuel Tanks

Condensation can form in partially filled fuel tanks. Top off the fuel tanks after operating the engine.

Fuel tanks should contain some provision for draining water and sediment from the bottom of the tanks. Some fuel tanks use supply pipes that allow water and sediment to settle below the end of the fuel supply pipe.

Some fuel tanks use supply lines that take fuel directly from the bottom of the tank. If the engine is equipped with this system, regular maintenance of the fuel system filter is important.

Drain the water and sediment from any fuel storage tank at the following intervals:

- Weekly
- Oil changes
- Refueling of the fuel tank

This draining will help prevent water and/or sediment from being pumped from the fuel storage tank and into the engine fuel tank.

#### Fuel Heaters

Fuel heaters help to prevent fuel filters from plugging in cold weather due to waxing. A fuel heater should be installed in order for the fuel to be heated before the fuel enters the primary fuel filter.

Select a fuel heater that is mechanically simple, yet adequate for the application. The fuel heater should also help to prevent overheating of the fuel. High fuel temperatures reduce engine performance and the availability of engine power. Choose a fuel heater with a large heating surface. The fuel heater should be practical in size. Small heaters can be too hot due to the limited surface area.

Disconnect the fuel heater in warm weather.

**Note:** Fuel heaters that are controlled by the water temperature regulator or self-regulating fuel heaters should be used with this engine. Fuel heaters that are not controlled by the water temperature regulator can heat the fuel in excess of 65° C (149° F). A loss of engine power can occur if the fuel supply temperature exceeds 37° C (100° F).

**Note:** Heat exchanger type fuel heaters should have a bypass provision in order to prevent overheating of the fuel in warm-weather operation.

For further information on fuel heaters, consult your Perkins distributor .

# Maintenance Section

## Refill Capacities

i07459920

## Refill Capacities

## Lubrication System

The refill capacities for the engine crankcase reflect the approximate capacity of the crankcase or sump plus standard oil filters. Auxiliary oil filter systems will require more oil. Refer to the Original Equipment Manufacture (OEM) specifications for the capacity of the auxiliary oil filter. Refer to the Operation and Maintenance Manual, "Maintenance Section" for more information on Lubricant Specifications.

Table 3

Engines Refill Capacities			
Engine Sales Model	Compartment or System	Minimum (1)	Maximum (2)
4006-23	Crankcase Oil Sump	90.7 L (23.9 US gal)	113.4 L (29.9 US gal)
4008-30	Crankcase Oil Sump	127 L (33.5 US gal)	153 L (40.4 US gal)

(1) These values are the total capacities for the crankcase oil sump which includes the standard factory installed oil filters and oil coolers. Engines with auxiliary oil filters will require more oil. Refer to the OEM specifications for the capacity of the auxiliary oil filter.

(2) Approximate capacity of the largest crankcase oil sump. Refer to OEM for more information.

## Cooling System

Table 4

4006-23 Engine and Engine with Radiator	
Engine Only	36 L (9.5 US gal)
Engine and Radiator	120 L (31.7 US gal)

Table 5

4008-30 Engine and Engine with Radiator	
Engine Only	48 L (10.5 Imp gal)
Engine and Radiator	140 L (30.8 Imp gal)

## Fuel System

Refer to the OEM specifications for additional information on the capacity of the fuel system.

i06519545

## Fluid Recommendations (General Coolant Information)

### General Coolant Information

**NOTICE**

Never add coolant to an overheated engine. Engine damage could result. Allow the engine to cool first.

**NOTICE**

If the engine is to be stored in, or shipped to an area with below freezing temperatures, the cooling system must be either protected to the lowest outside temperature or drained completely to prevent damage.

**NOTICE**

Frequently check the specific gravity of the coolant for proper freeze protection or for anti-boil protection.

Clean the cooling system for the following reasons:

- Contamination of the cooling system
- Overheating of the engine
- Foaming of the coolant

**NOTICE**

Never operate an engine without water temperature regulators in the cooling system. Water temperature regulators help to maintain the engine coolant at the proper operating temperature. Cooling system problems can develop without water temperature regulators.

Many engine failures are related to the cooling system. The following problems are related to cooling system failures: Overheating, leakage of the water pump and plugged radiators or heat exchangers.

These failures can be avoided with correct cooling system maintenance. Cooling system maintenance is as important as maintenance of the fuel system and the lubrication system. Quality of the coolant is as important as the quality of the fuel and the lubricating oil.

Coolant is normally composed of three elements: Water, additives, and glycol.

## Water

Water is used in the cooling system to transfer heat.

**Distilled water or deionized water is recommended for use in engine cooling systems.**

DO NOT use the following types of water in cooling systems: Hard water, softened water that has been conditioned with salt and sea water.

If distilled water or deionized water is not available, use water with the properties that are listed in Table 6 .

Table 6

Acceptable Water	
Property	Maximum Limit
Chloride (Cl)	40 mg/L
Sulfate (SO <sub>4</sub> )	100 mg/L
Total Hardness	170 mg/L
Total Solids	340 mg/L
Acidity	pH of 5.5 to 9.0

For a water analysis, consult one of the following sources:

- Local water utility company
- Agricultural agent
- Independent laboratory

## Additives

Additives help to protect the metal surfaces of the cooling system. A lack of coolant additives or insufficient amounts of additives enable the following conditions to occur:

- Corrosion
- Formation of mineral deposits
- Rust
- Scale
- Foaming of the coolant

Many additives are depleted during engine operation. These additives must be replaced periodically.

Additives must be added at the correct concentration. Over concentration of additives can cause the inhibitors to drop out-of-solution. The deposits can enable the following problems to occur:

- Formation of gel compounds
- Reduction of heat transfer
- Leakage of the water pump seal
- Plugging of radiators, coolers, and small passages

## Glycol

Glycol in the coolant helps to provide protection against the following conditions:

- Boiling
- Freezing
- Cavitation of the water pump

For optimum performance, Perkins recommends a 1:1 mixture of a water/glycol solution.

**Note:** Use a mixture that will provide protection against the lowest ambient temperature.

**Note:** 100 percent pure glycol will freeze at a temperature of  $-13^{\circ}\text{C}$  ( $8.6^{\circ}\text{F}$ ).

Most conventional antifreezes use ethylene glycol. Propylene glycol may also be used. In a 1:1 mixture with water, ethylene and propylene glycol provide similar protection against freezing and boiling. Refer to Table 7 and refer to table 8 .

Table 7

Ethylene Glycol	
Concentration	Freeze Protection
50 Percent	$-36^{\circ}\text{C}$ ( $-33^{\circ}\text{F}$ )
60 Percent	$-51^{\circ}\text{C}$ ( $-60^{\circ}\text{F}$ )

### NOTICE

Do not use propylene glycol in concentrations that exceed 50 percent glycol because of the reduced heat transfer capability of propylene glycol. Use ethylene glycol in conditions that require additional protection against boiling or freezing.

Table 8

Propylene Glycol	
Concentration	Freeze Protection
50 Percent	$-29^{\circ}\text{C}$ ( $-20^{\circ}\text{F}$ )

To check the concentration of glycol in the coolant, measure the specific gravity of the coolant.

## Coolant Recommendations

- ELC \_\_\_\_\_ Extended Life Coolant
- SCA \_\_\_\_\_ Supplement Coolant Additive
- ASTM \_\_\_\_\_ American Society for Testing and Materials

The following two coolants are used in Perkins diesel engines:

**Preferred** – Perkins ELC

**Acceptable** – A commercial heavy-duty antifreeze that meets “ASTM D6210” specifications

---

### NOTICE

**The Perkins industrial engines must be operated with a 1:1 mixture of water and glycol.**

---



---

### NOTICE

Do not use a commercial coolant/antifreeze that only meets the ASTM D3306 specification. This type of coolant/antifreeze is made for light automotive applications.

---

Perkins recommends a 1:1 mixture of water and glycol. This mixture of water and glycol will provide optimum heavy-duty performance as an antifreeze. This ratio may be increased to 1:2 water to glycol if extra freezing protection is required.

For applications that do not require freeze protection consult Perkins Engines Stafford Applications department.

Table 9

Coolant Service Life	
Coolant Type	Service Life <sup>(1)</sup>
Perkins ELC	6,000 Service Hours or Three Years
Commercial Heavy-Duty Antifreeze that meets “ASTM D6210”	3000 Service Hours or Two Year

<sup>(1)</sup> Use the interval that occurs first. The cooling system must also be flushed out now.

## ELC

Perkins provides ELC for use in the following applications:

- Heavy-duty spark ignited gas engines
- Heavy-duty diesel engines
- Automotive applications

The anti-corrosion package for ELC is different from the anti-corrosion package for other coolants. ELC is an ethylene glycol base coolant. However, ELC contains organic corrosion inhibitors and antifoam agents with low amounts of nitrite. Perkins ELC has been formulated with the correct amount of these additives to provide superior corrosion protection for all metals in engine cooling systems.

ELC is available in a premixed cooling solution with distilled water. ELC is a 1:1 mixture. The Premixed ELC provides freeze protection to  $-36\text{ }^{\circ}\text{C}$  ( $-33\text{ }^{\circ}\text{F}$ ). The Premixed ELC is recommended for the initial fill of the cooling system. The Premixed ELC is also recommended for topping off the cooling system.

Containers of several sizes are available. Consult your Perkins distributor for the part numbers.

## ELC Cooling System Maintenance

### Correct Additions to the Extended Life Coolant

---

#### NOTICE

Use only Perkins products for pre-mixed or concentrated coolants.

Mixing Extended Life Coolant with other products reduces the Extended Life Coolant service life. Failure to follow the recommendations can reduce cooling system components life unless appropriate corrective action is performed.

To maintain the correct balance between the antifreeze and the additives, you must maintain the recommended concentration of ELC. Lowering the proportion of antifreeze lowers the proportion of additive. Lowering the ability of the coolant to protect the system will form pitting, from cavitation, from erosion, and from deposits.

---

#### NOTICE

Do not use a conventional coolant to top-off a cooling system that is filled with Extended Life Coolant (ELC).

Do not use standard supplemental coolant additive (SCA).

When using Perkins ELC, do not use standard SCA's or SCA filters.

---

### ELC Cooling System Cleaning

**Note:** If the cooling system is already using ELC, cleaning agents are not required to be used at the specified coolant change interval. Cleaning agents are only required if the system has been contaminated by the addition of some other type of coolant or by cooling system damage.



Clean water is the only cleaning agent that is required when ELC is drained from the cooling system.

Before the cooling system is filled, the heater control (if equipped) must be set to the HOT position. Refer to the OEM to set the heater control. After the cooling system is drained and the cooling system is refilled, operate the engine until the coolant level reaches the normal operating temperature and until the coolant level stabilizes. As needed, add the coolant mixture to fill the system to the specified level.

## Changing to Perkins ELC

To change from heavy-duty antifreeze to the Perkins ELC, perform the following steps:

---

### NOTICE

Care must be taken to ensure that all fluids are contained during performance of inspection, maintenance, testing, adjusting and the repair of the product. Be prepared to collect the fluid with suitable containers before opening any compartment or disassembling any component containing fluids.

Dispose of all fluids according to local regulations and mandates.

1. Drain the coolant into a suitable container.
2. Dispose of the coolant according to local regulations.
3. Fill the cooling system with a 33 percent solution of Perkins ELC and operate the engine, ensure that the thermostat opens. Stop the engine and allow the engine to cool. Drain the coolant.

**Note:** Use distilled or deionized water in the solution.

4. Again, fill the cooling system with a 33 percent solution of Perkins ELC and operate the engine ensure that the thermostat opens. Stop the engine and allow to cool.
5. Drain the cooling system.

---

### NOTICE

Incorrect or incomplete flushing of the cooling system can result in damage to copper and other metal components.

6. Fill the cooling system with the Perkins Premixed ELC. Operate the engine. Ensure that all coolant valves open then stop the engine. When cool check the coolant level.

## ELC Cooling System Contamination

---

### NOTICE

Mixing ELC with other products reduces the effectiveness of the ELC and shortens the ELC service life. Use only Perkins Products for premixed or concentrate coolants. Failure to follow these recommendations can result in shortened cooling system component life.

ELC cooling systems can withstand contamination to a maximum of 10 percent of conventional heavy-duty antifreeze or SCA. If the contamination exceeds 10 percent of the total system capacity, perform ONE of the following procedures:

- Drain the cooling system into a suitable container. Dispose of the coolant according to local regulations. Flush the system with a 5 to 10 percent solution of Perkins ELC. Fill the system with the Perkins ELC.
- Drain a portion of the cooling system into a suitable container according to local regulations. Then, fill the cooling system with premixed ELC. This procedure should lower the contamination to less than 10 percent.
- Maintain the system as a conventional Heavy-Duty Coolant. Treat the system with an SCA. Change the coolant at the interval that is recommended for the conventional Heavy-Duty Coolant.

## Commercial Heavy-Duty Antifreeze and SCA

---

### NOTICE

Commercial Heavy-Duty Coolant which contains Amine as part of the corrosion protection system must not be used.

---

### NOTICE

Never operate an engine without water temperature regulators in the cooling system. Water temperature regulators help to maintain the engine coolant at the correct operating temperature. Cooling system problems can develop without water temperature regulators.

Check the antifreeze (glycol concentration) to ensure adequate protection against boiling or freezing. Perkins recommends the use of a refractometer for checking the glycol concentration. A hydrometer should not be used.

Perkins engine cooling systems should be tested at 500-hour intervals for the concentration of SCA.

Additions of SCA are based on the results of the test. An SCA that is liquid may be needed at 500-hour intervals.

### Adding the SCA to Heavy-Duty Coolant at the Initial Fill

Use the equation that is in Table 10 to determine the amount of SCA that is required when the cooling system is initially filled.

Table 10

<b>Equation For Adding The SCA To The Heavy-Duty Coolant At The Initial Fill</b>
$V \times 0.045 = X$
V is the total volume of the cooling system.
X is the amount of SCA that is required.

Table 13 is an example for using the equation that is in Table 12 .

Table 11

Example Of The Equation For Adding The SCA To The Heavy-Duty Coolant At The Initial Fill		
Total Volume of the Cooling System (V)	Multiplication Factor	Amount of SCA that is Required (X)
15 L (4 US gal)	× 0.045	0.7 L (24 oz)

### Adding The SCA to The Heavy-Duty Coolant For Maintenance

Heavy-duty antifreeze of all types REQUIRE periodic additions of an SCA.

Test the antifreeze periodically for the concentration of SCA. For the interval, refer to the Operation and Maintenance Manual, "Maintenance Interval Schedule" (Maintenance Section). Cooling System Supplemental Coolant Additive (SCA) Test/Add.

Additions of SCA are based on the results of the test. The size of the cooling system determines the amount of SCA that is needed.

Use the equation that is in Table 12 to determine the amount of SCA that is required, if necessary:

Table 12

<b>Equation For Adding The SCA To The Heavy-Duty Coolant For Maintenance</b>
$V \times 0.014 = X$
V is the total volume of the cooling system.
X is the amount of SCA that is required.

Table 13 is an example for using the equation that is in Table 12 .

Table 13

Example Of The Equation For Adding The SCA To The Heavy-Duty Coolant For Maintenance		
Total Volume of the Cooling System (V)	Multiplication Factor	Amount of SCA that is Required (X)
15 L (4 US gal)	× 0.014	0.2 L (7 oz)

### Cleaning the System of Heavy-Duty Antifreeze

- Clean the cooling system after used coolant is drained or before the cooling system is filled with new coolant.
- Clean the cooling system whenever the coolant is contaminated or whenever the coolant is foaming.

i07425855

## Fluid Recommendations (General Fuel Information)

- **Glossary**
- ISO International Standards Organization
- ASTM American Society for Testing and Materials
- HFRR High Frequency Reciprocating Rig for Lubricity testing of diesel fuels
- CFR Co-ordinating Fuel Research
- LSD Low Sulfur Diesel
- ULSD Ultra Low Sulfur Diesel
- CPCB Central Pollution Control Board of India

### General Information

**NOTICE**

Every attempt is made to provide accurate, up-to-date information. By use of this document you agree that Perkins Engines Company Limited is not responsible for errors or omissions.

## NOTICE

These recommendations are subject to change without notice. Contact your local Perkins distributor for the most up-to-date recommendations.

## Diesel Fuel Requirements

Satisfactory engine performance is dependent on the use of a good quality fuel. The use of a good quality fuel will give the following results: long engine life and acceptable exhaust emissions levels. The fuel must meet the minimum requirements that are stated in table 14 .

## NOTICE

The footnotes are a key part of the Specification for Indian Distillate Diesel Fuel Table. Read ALL of the footnotes.

Table 14

Specification for Indian IS1460 Distillate Diesel Fuel(1)					
Property	UNITS	Requirements	"ASTM Test"	"ISO Test"	"India Test"
Polycyclic Aromatics	%m/m	11% maximum	-	"ISO 12916"	-
Ash	%Weight	0.01% maximum	"D482"	"ISO 6245"	"IS 1448 P:4"
Carbon Residue on 10% Bottoms	%Weight	0.3% maximum	"D524"	"ISO 4262"	"IS 1448 P:8"
Cetane Number (1)	-	51 minimum	"D613 or D6890"	"ISO 5165"	"IS 1448 P:9"
Cetane Index	-	46 minimum	"D4737"	"ISO 4264"	-
Cloud Point	°C	The cloud point must not exceed the lowest expected ambient temperature.	"D2500 or D5773"	"ISO 3015"	-
Copper Strip Corrosion	-	No. 3 maximum	"D130"	"ISO 2160"	"IS 1448 P:12"
Distillation	°C	95% at 360 °C (680 °F) maximum	"D86"	"ISO 3405"	"IS 1448 P:18"
Density at 15 °C (59 °F) (2)	Kg / m <sup>3</sup>	820 minimum and 845 maximum	No equivalent test	"ISO 3675" or "ISO 12185"	"IS 1448 P:16"
Flash Point Pensky-Martens	°C	66	"D93"	"ISO 2719"	"IS 1448 P:21"
Thermal Stability	-	Minimum of 80% reflectance after aging for 180 minutes at 150 °C (302 °F)	"D6468"	No equivalent test	-
Pour Point	°C	3° C (37.4° F) Winter 15° C (59° F) Summer	"D97"	"ISO 3016"	"IS 1448 P:10"
Sulfur	mg/kg	350 maximum (3)	"D5453 or /D2622"	"ISO 20846" or "ISO 20884"	"IS 1448 P:34"

(continued)

Maintenance Section  
General Fuel Information

(Table 14, contd)

Kinematic Viscosity at 40° C (104° F) <sup>(4)</sup>	mm <sup>2</sup> /S (cSt)	The viscosity of the fuel that is delivered to the fuel injection pump. 2 minimum and 4.5 maximum	"D445"	"ISO 3405"	"IS 1448 P:25"
Water	mg/kg	200 maximum	"D1744"	ISO 12937	IS 1448 P:40
Gums and Resins <sup>(5)</sup>	mg/100mL	10 mg per 100 mL maximum	"D381"	"ISO 6246"	-
Lubricity corrected-wear scar diameter at 60° C (140° F). <sup>(6)</sup>	mm	0.46 maximum	"D6079"	"ISO 12156-1"	-
Fuel cleanliness <sup>(7)</sup>	-	"ISO"18/16/13	7619	"ISO 4406"	-
Oxidation Stability	g/m <sup>3</sup>	Max 25	D2274	ISO 12205	-

- (1) A fuel with a higher cetane number is recommended to operate at a higher altitude or in cold weather.
- (2) Density range allowed includes summer and winter diesel fuel grades. Fuel density varies depending on the sulfur level where high sulfur fuels have higher densities. Some unblended alternative fuels have lower densities which are acceptable if all the other properties meet this specification.
- (3) Regional regulations or international regulations can require a fuel with a specific sulfur limit. LSD fuel with less than 0.035 percent ( $\leq 350$  ppm (mg/kg)) sulfur is strongly recommended for use in these engine models. Diesel fuel with more than 0.035 percent ( $\geq 350$  ppm (mg/kg)) sulphur can be used only where allowed by legislation. Fuel sulfur levels affect exhaust emissions. High sulfur fuels also increase the potential for corrosion of internal components. Fuel sulfur levels above 0.035% may significantly shorten the oil change interval. For additional information, refer to **General Lubricant Information**.
- (4) The values of the fuel viscosity are the values as the fuel is delivered to the fuel injection pumps. Fuel should also meet the minimum viscosity requirement and the fuel should meet the maximum viscosity requirements at 40° C (104° F) of either the "ASTM D445" test method, "ISO 3104" test method or the "IS 1448" test method. If a fuel with a low viscosity is used, cooling of the fuel may be required to maintain 2.0 cSt or greater viscosity at the fuel injection pump. Fuels with a high viscosity might require fuel heaters to lower the viscosity to 4.5 cSt at the fuel injection pump.
- (5) Follow the test conditions and procedures for gasoline (motor).
- (6) The lubricity of a fuel is a concern with low sulfur and ultra low sulfur fuel. To determine the lubricity of the fuel, use the "ISO 12156-1 or ASTM D6079 High Frequency Reciprocating Rig (HFRR)" test. If the lubricity of a fuel does not meet the minimum requirements, consult your fuel supplier. Do not treat the fuel without consulting the fuel supplier. Some additives are not compatible. These additives can cause problems in the fuel system.
- (7) Recommended cleanliness level for fuel as dispensed into machine or engine fuel tank is "ISO 18/16/13 or cleaner as per ISO 4406. Refer to the "Contamination Control Recommendations for Fuels" in this chapter.

### NOTICE

Operating with fuels that do not meet the Perkins recommendations can cause the following effects: Starting difficulty, poor combustion, deposits in the fuel injectors, reduced service life of the fuel system, deposits in the combustion chamber, and reduced service life of the engine.

**Note:** The owner and the operator of the engine has the responsibility of using the fuel that is prescribed by the Central Pollution Control Board of India (CPCB) and other appropriate regulatory agencies.

The specifications that are listed in the table below are released as acceptable to use

Table 15

Acceptable Fuel Specification for the 4006 and 4008 Series of Engines <sup>(1)</sup>	
Fuel Specification	Description
IS 1460 Bharat Stage 3 and Stage 4	Indian Distillate diesel fuel specification

## Diesel Fuel Characteristics

Perkins Recommendations

### Cetane Number

Cetane number is a measure of the ignition quality of diesel fuel. Fuel that has a higher cetane number will give a shorter ignition delay and will produce a better ignition quality.

Cetane numbers are derived for fuels against proportions of cetane and heptamethylnonane in the standard CFR engine. Refer to "ISO 5165" for the test method.

For these engines minimum cetane number requirement is 51. Cetane number affect engine cold start ability, exhaust emissions, combustion noise, and altitude performance. Fuel with higher Cetane number is desirable and recommended. This is particularly important for operations in cold weather and at high altitude.

## Viscosity

Viscosity is the property of a liquid of offering resistance to shear or flow. Viscosity decreases with increasing temperature. This decrease in viscosity follows a logarithmic relationship for normal fossil fuel. The common reference is to kinematic viscosity. Kinematic viscosity is the quotient of the dynamic viscosity that is divided by the density. The determination of kinematic viscosity is normally by readings from gravity flow viscometers at standard temperatures. Refer to "ISO 3104" for the test method.

The viscosity of the fuel is significant because fuel serves as a lubricant for the fuel system components. Fuel must have sufficient viscosity to lubricate the fuel system in both extremely cold temperatures and extremely hot temperatures. If the kinematic viscosity of the fuel is lower than 2 mm<sup>2</sup>/sec that is delivered to the fuel injection pump. If a fuel with a low viscosity is used, cooling of the fuel may be required to maintain 2 cSt or greater viscosity at the fuel injection pump. Fuels with a high viscosity might require fuel heaters to lower the viscosity to 4.5 cSt at the fuel injection pump

## Density

Density is the mass of the fuel per unit volume at a specific temperature. This parameter has a direct influence on engine performance and a direct influence on emissions. This determines the heat output from a given injected volume of fuel. This is quoted in the following kg/m<sup>3</sup> at 15 °C (59 °F).

Perkins recommends a value of density 820 to 845 kg/m<sup>3</sup> to obtain the correct power output. Lighter fuels are acceptable but these fuels will not produce the rated power.

## Sulfur

The level of sulfur is governed by emissions legislations. Regional regulation, national regulations, or international regulations can require a fuel with a specific sulfur limit. The sulphur content of the fuel and the fuel quality must comply with all existing local regulations for emissions.

In India fuel meeting sulphur limits of Bharat stage 3 and Bharat stage 4 specifications must be used in these engine models.

Bharat stage 3 regulations require use of low sulphur diesel fuel with less than 0.035 percent (350 PPM) (mg/kg) sulphur content.

Bharat stage 4 regulations require use of low sulphur diesel fuel with less than 0.050 percent (50 PPM) (mg/kg) sulphur content.

The lubricity of these fuels must not exceed wear scar diameter of 0.46 mm (0.01811 inch) as per "ISO 12156-1". Refer to "Lubricity" for more information.

Fuels with sulphur content higher than 0.035 percent (350 PPM) can be only used where allowed by legislation. High sulfur fuel will have a negative impact on emissions of particulates. High sulfur fuels also increase potential for corrosion and wear of internal component and may significantly shorten the oil change interval.

## Lubricity

This is the capability of the fuel to prevent pump wear. The lubricity of the fluid describes the ability of the fluid to reduce the friction between surfaces that are under load. This ability reduces the damage that is caused by friction. Fuel injection systems rely on the lubricating properties of the fuel. Until fuel sulphur limits were mandated, the lubricity of the fuel was believed to be a function of fuel viscosity.

The lubricity has particular significance to the current low viscosity fuel, low sulfur fuel, and low aromatic fossil fuel. These fuels are made to meet stringent exhaust emissions. The lubricity of these fuels must not exceed wear scar diameter of 0.46 mm (0.01811 inch). The fuel lubricity test must be performed on an HFRR, operated at 60° C (140° F). Refer to "ISO 12156-1".

---

### NOTICE

The fuels system has been qualified with fuel having lubricity up to 0.46 mm (0.01811 inch) wear scar diameter as tested by "ISO 12156-1". Fuel with higher wear scar diameter than 0.46 mm (0.01811 inch) will lead to reduced service life and premature failure of the fuel system.

---

In case of the fuels which do not meet specified lubricity requirement appropriate lubricity additive can be used to enhance the lubricity of the fuel. Contact your fuel supplier for those circumstances when fuel additives are required. Your fuel supplier can make recommendations for additives to use and for the proper level of treatment.

## Aftermarket Fuel Additives

### NOTICE

Perkins does not warrant the quality or performance of non-Perkins fluids and filters. When auxiliary devices, accessories, or consumables (filters, additives) which are made by other manufacturers are used on Perkins products, the Perkins warranty is not affected simply because of such use.

**However, failures that result from the installation or use of other manufacturers devices, accessories, or consumables are NOT Perkins defects. Therefore, the defects are NOT covered under the Perkins warranty.**

Supplemental diesel fuel additives are not recommended. This is due to potential damage to the fuel system or the engine. Your fuel supplier or the fuel manufacturer will add the appropriate supplemental diesel fuel additives.

Perkins recognizes the fact that additives may be required in some special circumstances. Fuel additives need to be used with caution. Contact your fuel supplier for those circumstances when fuel additives are required. Your fuel supplier can recommend the appropriate fuel additive and the correct level of treatment.

**Note:** For the best results, your fuel supplier should treat the fuel when additives are required. The treated fuel must meet the requirements that are stated in table 14 .

## Perkins Diesel Fuel System Cleaner

Perkins Diesel Fuel Cleaner (part number T400012) is the only fuel cleaner that is recommended by Perkins.

Perkins fuel cleaner will remove deposits that can form in the fuel system. These deposits can create a loss of power and engine performance.

Once the fuel cleaner has been added to the fuel, the deposits within the fuel system are removed after 30 hours of engine operation. For maximum results, continue to use the fuel cleaner for up to 80 hours. Perkins fuel cleaner can be used on an on-going basis with no adverse impact on engine or fuel system durability.

Detailed instructions on the rate of which the fuel cleaner must be use are on the container.

## Contamination Control Recommendations for Fuels

Fuels of "ISO 18/16/13" cleanliness level or cleaner as dispensed into the engine or application fuel tank should be used. This action will reduce risk of power loss, fuel system failures, and related down time of engines. This cleanliness level is important for new fuel system designs such as common rail injection systems and unit injectors. These fuels systems utilize higher fuel injection pressures and have tight clearances between moving parts to meet required stringent emissions regulations. Peak injection pressures in current fuel injection systems may exceed 2000 bar (29000 psi). Clearances in these systems are less than 5 µm. As a result, particle contaminants as small as 4 µm can cause scoring and scratching of internal pump and injector surfaces and of injector nozzle.

Water in the fuel causes cavitation, corrosion of fuel system parts, and provides an environment where microbial growth in the fuel can flourish. Other sources of fuel contamination are soaps, gels, or other compounds that may result from undesirable chemical interactions in the fuels, particularly in ULSD. Gels and other compounds can also form in biodiesel fuel at low temperatures or if biodiesel is stored for extended periods. The best indication of microbial contamination, fuel additives, or cold temperature gel is rapid filter plugging of bulk fuel filters or application fuel filters.

To reduce downtime due to contamination, follow these fuel maintenance guidelines.

- Use high-quality fuels per recommended and required specifications
- Fill fuel tanks with fuels of "ISO 18/16/13" cleanliness level or cleaner, in particular for engines with common rail and unit injection systems. When you refuel the tank, filter the fuel through a 4 µm absolute filter (Beta 4 = 75 up to 200) in order to reach the recommended cleanliness level. This filtration should be located at the device that dispenses the fuel to the fuel tank. In addition, filtration at the dispensing point should remove water to ensure that fuel is dispensed at 200 ppm water or less.
- Perkins recommends the use of bulk fuel filter / coalescer units which clean the fuel of both particulate contamination and water in a single pass.
- Ensure that you use Perkins Advanced Efficiency Fuel Filters. Change your fuel filters per recommended service requirements or as needed.
- Drain your water separators daily.

- Drain your fuel tanks of sediment and water per the Operation and Maintenance Manual instructions.
- Install and maintain a properly designed bulk filter / coalescer filtration system. Continuous bulk filtration systems may be required to ensure that dispensed fuel meets the cleanliness target. Consult your Perkins distributor for availability of bulk filtration products.
- Centrifugal filters may need to be used as a pre-filter with fuel that is severely contaminated with gross amounts of water and/or large particulate contaminants. Centrifugal filters can effectively remove large contaminants. Centrifugal filters may not be able to remove the small abrasive particles required to achieve the recommended "ISO" cleanliness level. Bulk filter / coalescers are necessary as a final filter to achieve the recommended cleanliness level.
- Install desiccant type breathers of 4 µm or less absolute efficiency with the ability to remove water on bulk storage tanks.
- Follow proper practices of fuel transportation. Filtration from the storage tank to the application promotes the delivery of clean fuel. Fuel filtration can be installed at each transport stage to keep the fuel clean.
- Cover, protect, and ensure cleanliness of all connection hoses, fittings, and dispensing nozzles.

Consult your local Perkins distributor for additional information on Perkins designed and produced filtration products.

i07436307

## Fluid Recommendations (Engine Oil Specification)

### General Lubricant Information

Because of government regulations regarding the certification of exhaust emissions from the engine, the lubricant recommendations must be followed.

- API \_\_\_\_\_ American Petroleum Institute
- SAE \_\_\_\_\_ Society Of Automotive Engineers Inc.
- ECF \_\_\_\_\_ Engine Crankcase Fluid

### Licensing

The Engine Oil Licensing and Certification System by the American Petroleum Institute (API) is recognized by Perkins. For detailed information about this system, see the latest edition of the "API publication No. 1509". Engine oils that bear the API symbol are authorized by API.

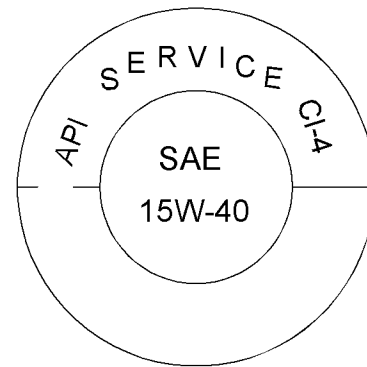

Illustration 26

g03360267

Typical API symbol

### Terminology

Certain abbreviations follow the nomenclature of "SAE J754". Some classifications follow "SAE J183" abbreviations, and some classifications follow the "EMA Recommended Guideline on Diesel Engine Oil". In addition to Perkins definitions, there are other definitions that will be of assistance in purchasing lubricants. Recommended oil viscosities can be found in this publication, "Fluid Recommendations/ Engine Oil Specification" topic (Maintenance Section).

### Engine Oil

#### Perkins Diesel Engine Oil

Perkins DEO CI-4 oil is the preferred oil. Perkins multi-grade oil has been developed and tested to provide full performance and service life that has been designed and built into Perkins Engines. Consult your Perkins distributors for more information.

#### Commercial Oils

##### NOTICE

**Perkins require the use of the following specification of engine oil. Failure to use the appropriate specification of engine oil will reduce the life of your engine.**

Table 16

Minimum Oil Specification for 4006-23 and the 4008-30 Industrial Engines	
Oil Specification	API CI-4 ECF-2

## Lubricant Viscosity Recommendations for Direct Injection (DI) Diesel Engines

The correct SAE viscosity grade of oil is determined by the minimum ambient temperature during cold engine start-up, and the maximum ambient temperature during engine operation.

Refer to illustration 27 (minimum temperature) to determine the required oil viscosity for starting a cold engine.

Refer to illustration 27 (maximum temperature) to select the oil viscosity for engine operation at the highest ambient temperature that is anticipated.

Generally, use the highest oil viscosity that is available to meet the requirement for the temperature at start-up.

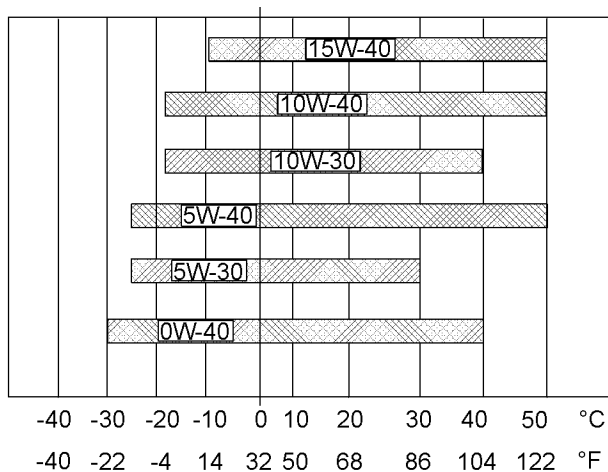

Illustration 27

g03347115

### Lubricant Viscosities

Supplemental heat is recommended for cold soaked starts below the minimum ambient temperature. Supplemental heat may be required for cold soaked starts that are above the minimum temperature that is stated, depending on the parasitic load and other factors. Cold soaked starts occur when the engine has not been operated for a period of time. This interval will allow the oil to become more viscous due to cooler ambient temperatures.

## Aftermarket Oil Additives

Perkins does not recommend the use of aftermarket additives in oil. It is not necessary to use aftermarket additives to achieve the engines maximum service life or rated performance. Fully formulated, finished oils consist of base oils and of commercial additive packages. These additive packages are blended into the base oils at precise percentages to help provide finished oils with performance characteristics that meet industry standards.

There are no industry standard tests that evaluate the performance or the compatibility of aftermarket additives in finished oil. Aftermarket additives may not be compatible with the finished oils additive package, which could lower the performance of the finished oil. The aftermarket additive could fail to mix with the finished oil. This failure could produce sludge in the crankcase. Perkins discourages the use of aftermarket additives in finished oils.

To achieve the best performance from a Perkins engine, conform to the following guidelines:

- See the appropriate "Lubricant Viscosities". Refer to the illustration 27 to find the correct oil viscosity grade for your engine.
- At the specified interval, service the engine. Use new oil and install a new oil filter.
- Perform maintenance at the intervals that are specified in the Operation and Maintenance Manual, "Maintenance Interval Schedule or Fluid Recommendations Fuel Specification".

## Oil analysis

Some engines may be equipped with an oil sampling valve. If oil analysis is required, the oil sampling valve is used to obtain samples of the engine oil. The oil analysis will complement the preventive maintenance program.

The oil analysis is a diagnostic tool that is used to determine oil performance and component wear rates. Contamination can be identified and measured by using oil analysis. The oil analysis includes the following tests:

- The Wear Rate Analysis monitors the wear of the engines metals. The amount of wear metal and type of wear metal that is in the oil is analyzed. The increase in the rate of engine wear metal in the oil is as important as the quantity of engine wear metal in the oil.



- Tests are conducted to detect contamination of the oil by water, glycol, or fuel.
- The Oil Condition Analysis determines the loss of the oils lubricating properties. An infrared analysis is used to compare the properties of new oil to the properties of the used oil sample. This analysis allows technicians to determine the amount of deterioration of the oil during use. This analysis also allows technicians to verify the performance of the oil according to the specification during the entire oil change interval.

# Maintenance Recommendations

i07218310

## Severe Service Application

Severe service is the application of an engine that exceeds the current published standards for that engine. Perkins maintains standards for the following engine parameters:

- Performance such as power range, speed range, and fuel consumption
- Fuel quality
- Operational Altitude
- Maintenance intervals
- Oil selection and maintenance
- Coolant type and maintenance
- Environmental qualities
- Installation
- The temperature of the fluid in the engine

Refer to the standards for the engine or consult your Perkins distributor to determine if the engine is operating within the defined parameters.

Severe service operation can accelerate component wear. Engines that operate under severe conditions may need more frequent maintenance intervals to ensure maximum reliability and retention of full service life.

Perkins engines are unable to identify all the factors which can contribute to severe service operation, due to individual applications. Consult your Perkins dealer or your Perkins distributor for the unique maintenance that is necessary for the engine.

The operating environment, incorrect operating procedures, and incorrect maintenance procedures can be factors which contribute to a severe service application.

## Environmental Factors

**Ambient temperatures** – The engine may be exposed to extended operation in extremely cold environments or hot environments. Valve components can be damaged by carbon buildup if the engine is frequently started and stopped in very cold temperatures. Extremely hot intake air reduces engine performance.

**Quality of the air** – The engine may be exposed to extended operation in an environment that is dirty or dusty, unless the equipment is cleaned regularly. Mud, dirt, and dust can encase components. Maintenance can become very difficult. The buildup can contain corrosive chemicals.

**Buildup** – Compounds, elements, corrosive chemicals, and salt can damage some components.

**Altitude** – Problems can arise when the engine is operated at altitudes that are higher than the intended settings for that application. Necessary adjustments should be made.

## Incorrect Operating Procedures

- Frequent hot shutdowns
- Operating at excessive loads
- Operating at excessive speeds
- Operating outside the intended application

## Incorrect Maintenance Procedures

- Extending the maintenance intervals
- Failure to use recommended fuel, lubricants, and coolant/antifreeze

i08037273

# Maintenance Interval Schedule

## When Required

- “ Battery - Replace” . . . . . 52
- “ Battery or Battery Cable - Disconnect” . . . . . 53
- “ Engine - Clean” . . . . . 62
- “ Engine Air Cleaner Element - Replace” . . . . . 62
- “ Fuel System - Prime” . . . . . 69
- “Overhaul (Major)” . . . . . 77

## Daily

- “ Cooling System Coolant Level - Check” . . . . . 61
- “ Driven Equipment - Check” . . . . . 62
- “ Engine Air Cleaner Service Indicator - Inspect” . . . 63
- “ Engine Oil Level - Check” . . . . . 65
- “ Fuel System Primary Filter/Water Separator - Drain” . . . . . 71
- “Walk-Around Inspection” . . . . . 80

## Every 50 Service Hours or Weekly

- “ Fuel Tank Water and Sediment - Drain” . . . . . 72

## Initial 100 Service Hours

- “ Alternator Pulley - Check” . . . . . 52
- “ Fan Drive Pulley - Check” . . . . . 68

## Every 300 Service Hours

- “ Engine Oil and Filter - Change” . . . . . 66

## Initial 500 Service Hours

- “ Engine Valve Lash - Inspect/Adjust” . . . . . 68
- “ Fuel Injector - Inspect/Adjust” . . . . . 69

## Every 500 Service Hours or 1 Year

- “ Battery Electrolyte Level - Check” . . . . . 53
- “ Belts - Inspect/Adjust/Replace” . . . . . 56
- “ Belts - Inspect/Adjust/Replace” . . . . . 57

- “ Engine Crankcase Breather - Clean” . . . . . 64
- “ Fuel System Primary Filter - Replace” . . . . . 70

## Every 1000 Service Hours or 1 Year

- “ Fuel System Secondary Filter - Replace” . . . . . 71

## Every Year

- “ Crankshaft Vibration Damper - Inspect” . . . . . 61
- “ Engine Mounts - Inspect” . . . . . 64
- “ Engine Protective Devices - Check” . . . . . 68

## Every 1000 Service Hours

- “ Aftercooler Core - Inspect” . . . . . 52
- “ Radiator - Clean” . . . . . 79

## Every 2000 Service Hours

- “ Engine Valve Lash - Inspect/Adjust” . . . . . 68
- “ Fuel Injector - Inspect/Adjust” . . . . . 69

## Every 6000 Service Hours or 3 Years

- “ Cooling System Coolant (ELC) - Change” . . . . . 58

## Every 7500 Service Hours

- “ Alternator - Inspect” . . . . . 52
- “ Engine Oil Pump - Inspect” . . . . . 65
- “ Fuel Injector - Replace” . . . . . 69
- “ Fuel Transfer Pump (Lift Pump) - Inspect” . . . . . 73
- “ Starting Motor - Inspect” . . . . . 80
- “ Turbocharger - Inspect” . . . . . 80
- “ Water Pump - Inspect” . . . . . 81

i06533191

## Aftercooler Core - Inspect

The aftercooler is combined with the radiator, inspect the aftercooler after the radiator and aftercooler has been cleaned.

Inspect the aftercooler for damaged fins, corrosion, dirt, grease, insects, leaves, oil, and other debris. Bent fins may be opened with a "comb". Inspect these items for good condition: Welds, mounting brackets, air lines, connections, clamps, and seals. Make repairs, if necessary.

i07398055

## Alternator - Inspect

Perkins recommends a scheduled inspection of the alternator. Inspect the alternator for loose connections and correct battery charging. Check the ammeter (if equipped) during engine operation in order to ensure correct battery performance and/or correct performance of the electrical system. Make repairs, as required.

Check the alternator and the battery charger for correct operation. If the batteries are correctly charged, the ammeter reading should be very near zero. All batteries should be kept charged. The batteries should be kept warm because temperature affects the cranking power. If the battery is too cold, the battery will not crank the engine. When the engine is not run for long periods of time or if the engine is run for short periods, the batteries may not fully charge. A battery with a low charge will freeze more easily than a battery with a full charge.

i07213693

## Alternator Pulley - Check

1. Isolate the electrical supply to the engine. Remove guard cover from alternator. Refer to Operation and Maintenance Manual, Belts- Inspect/Adjust/Replace (Alternator Belt) for removal of the cover guards.

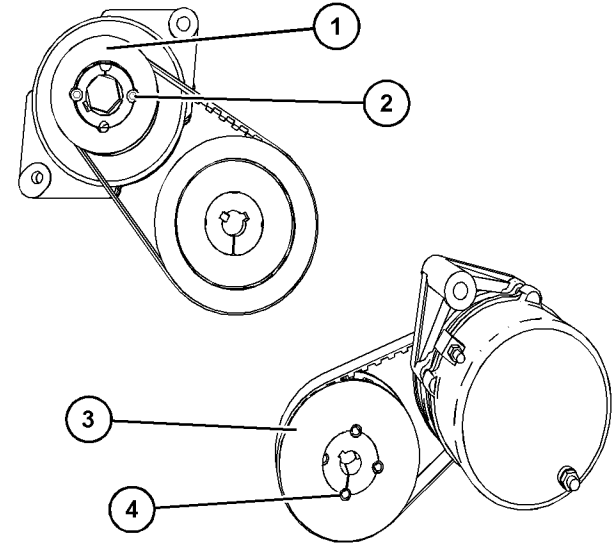

Illustration 28

g06254152

Typical example

2. Check the torque of the lock screws (2) on the alternator pulley (1). Also, Check to torque of the lock screws (4) on the drive pulley (3).
3. The lock screw torque is 20 N·m (177 lb in).
4. Install guard cover to alternator, refer to Operation and Maintenance Manual, Belts- Inspect/Adjust/Replace (Alternator Belt) for more information.
5. Connect power supply.

i02322315

## Battery - Replace

### WARNING

**Batteries give off combustible gases which can explode. A spark can cause the combustible gases to ignite. This can result in severe personal injury or death.**

**Ensure proper ventilation for batteries that are in an enclosure. Follow the proper procedures in order to help prevent electrical arcs and/or sparks near batteries. Do not smoke when batteries are serviced.**

**⚠ WARNING**

The battery cables or the batteries should not be removed with the battery cover in place. The battery cover should be removed before any servicing is attempted.

Removing the battery cables or the batteries with the cover in place may cause a battery explosion resulting in personal injury.

1. Switch the engine to the OFF position. Remove all electrical loads.
2. Turn off any battery chargers. Disconnect any battery chargers.
3. The NEGATIVE “-” cable connects the NEGATIVE “-” battery terminal to the NEGATIVE “-” terminal on the starting motor. Disconnect the cable from the NEGATIVE “-” battery terminal.
4. The POSITIVE “+” cable connects the POSITIVE “+” battery terminal to the POSITIVE “+” terminal on the starting motor. Disconnect the cable from the POSITIVE “+” battery terminal.

**Note:** Always recycle a battery. Never discard a battery. Dispose of used batteries to an appropriate recycling facility.

5. Remove the used battery.
6. Install the new battery.

**Note:** Before the cables are connected, ensure that the engine start switch is OFF.

7. Connect the cable from the starting motor to the POSITIVE “+” battery terminal.
8. Connect the NEGATIVE “-” cable to the NEGATIVE “-” battery terminal.

i02747977

## Battery Electrolyte Level - Check

When the engine is not run for long periods of time or when the engine is run for short periods, the batteries may not fully recharge. Ensure a full charge in order to help prevent the battery from freezing. If batteries are correctly charged, the ammeter reading should be very near zero, when the engine is in operation.

**⚠ WARNING**

All lead-acid batteries contain sulfuric acid which can burn the skin and clothing. Always wear a face shield and protective clothing when working on or near batteries.

1. Remove the filler caps. Maintain the electrolyte level to the “FULL” mark on the battery.

If the addition of water is necessary, use distilled water. If distilled water is not available use clean water that is low in minerals. Do not use artificially softened water.

2. Check the condition of the electrolyte with a suitable battery tester.
3. Install the caps.
4. Keep the batteries clean.

Clean the battery case with one of the following cleaning solutions:

- Use a solution of 0.1 kg (0.2 lb) baking soda and 1 L (1 qt) of clean water.
- Use a solution of ammonium hydroxide.

Thoroughly rinse the battery case with clean water.

i07819485

## Battery or Battery Cable - Disconnect

**⚠ WARNING**

The battery cables or the batteries should not be removed with the battery cover in place. The battery cover should be removed before any servicing is attempted.

Removing the battery cables or the batteries with the cover in place may cause a battery explosion resulting in personal injury.

1. Turn the start switch to the OFF position. Turn the ignition switch (if equipped) to the OFF position and remove the key and all electrical loads.
2. Disconnect the negative battery terminal. Ensure that the cable cannot contact the terminal. When four 12 volt batteries are involved, two negative connection must be disconnected.
3. Remove the positive connection.

4. Clean all disconnected connection and battery terminals.
5. Use a fine grade of sandpaper to clean the terminals and the cable clamps. Clean the items until the surfaces are bright or shiny. DO NOT remove material excessively. Excessive removal of material can cause the clamps to not fit correctly. Coat the clamps and the terminals with a suitable silicone lubricant or petroleum jelly.
6. Tape the cable connections to help prevent accidental starting.
7. Proceed with necessary system repairs.
8. To connect the battery, connect the positive connection before the negative connection.

i06683187

## Belts - Inspect/Adjust/Replace (Fan Drive Belts for 4008-30 Only)

### Inspection

1. Isolate the electrical supply to the engine.
2. Visibly inspect fan guards for wear or damage. Repair as necessary.

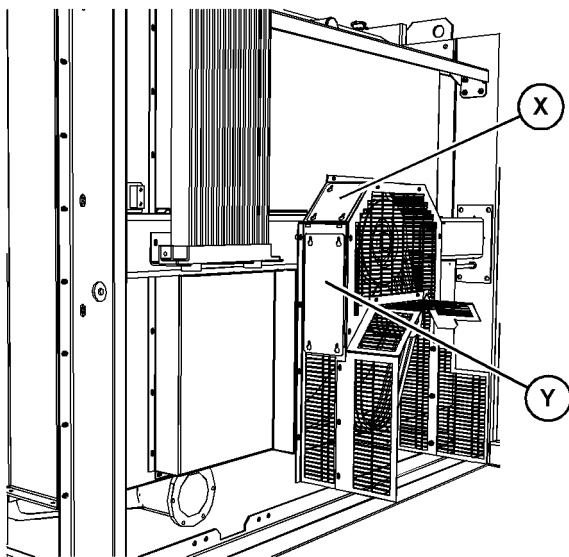

Illustration 29

g06022928

Typical example

3. Remove the inspection guard (X) and inspection guard (Y).

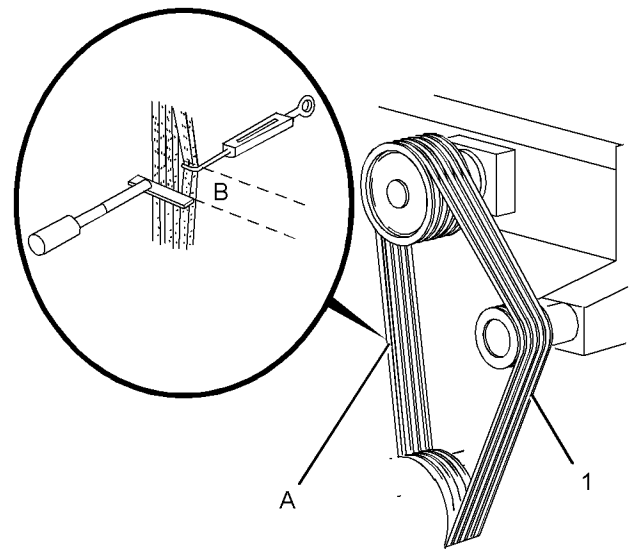

Illustration 30

g02025316

Typical example

4. Inspect the belts (1) for cracks. Inspect the belts for contamination. If necessary, replace the belts. Refer to "Replacement" for more information.
5. The belt tension must be checked at position A. Use a suitable spring balance and a suitable straight edge to check the belt tension.
6. The belt tension should be 62 N (14 lb) with a maximum deflection at position B of 16 mm (0.63 inch).
7. Adjust the belts if the belt tension exceeds or is below 62 N (14 lb). Refer to "Adjustment" for more information.
8. Install the inspection guard (X) and inspection guard (Y).
9. Restore the electrical supply to the engine.

### Adjustment

1. Ensure that the electrical supply to the engine is isolated. As required, remove the guards.

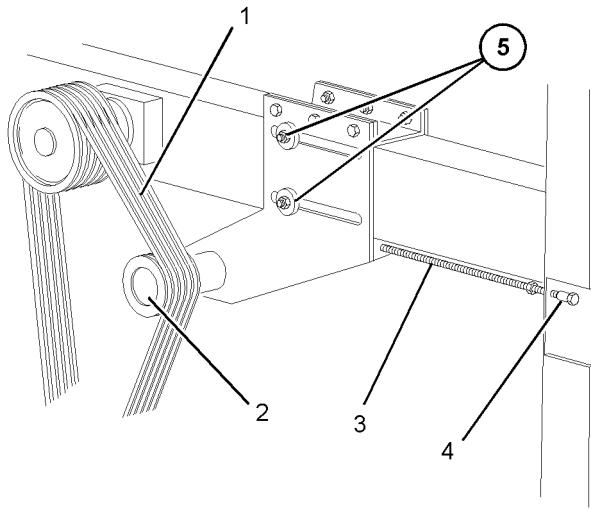

Illustration 31

g06021378

**Typical example**

2. Loosen bolts (5) and loosen the locknut (4).
3. Rotate the rod (3) to achieve the correct tension of belts (1). Refer to "Inspection" for the correct specification.
4. Tighten the locknut (4) to a torque of 120 N·m (88.5 lb ft). Tighten bolts (5) securely.
5. Ensure that the electrical supply to the engine is isolated. Install the guards.

**Replacement**

**Note:** Fan drive belts must be replaced as a set. Do not replace individual belts.

**Removal of the Fan Drive Belts**

Illustration 32

g06021378

**Typical example**

1. Ensure that the electrical supply to the engine is isolated. As required, remove the guards.
2. Loosen bolts (5) and loosen the locknut (4).
3. Rotate the rod (3) until the pulley (2) is toward the center of the engine.
4. Remove the belts (1).

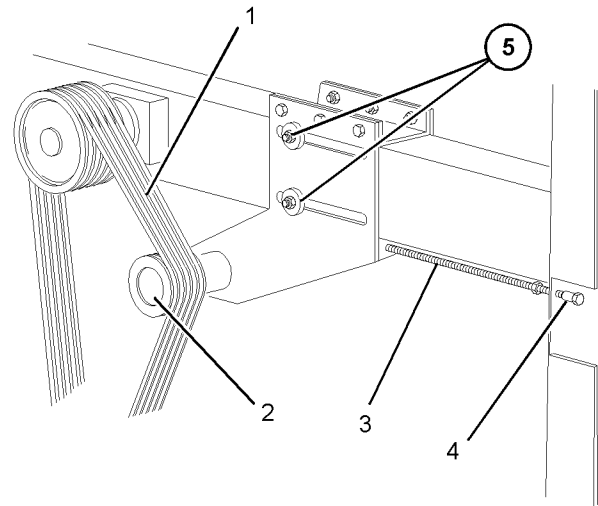
**Installation of the Fan Drive Belts**

1. Install new belts (1) over the pulleys.
2. Rotate the rod (3) to achieve an initial tension of 77 N (17 lb). The total deflection should not exceed 16 mm (0.63 inch).
3. Tighten the locknut (4) to a torque of 120 N·m (88.5 lb ft). Tighten bolts (5) securely.
4. Rotate the pulleys for the fan drive belts three to four revolutions to ensure that the fan drive belts are correctly installed. Ensure that the tension is still 77 N (17 lb).
5. Restore the electrical supply to the engine. Install the guards.
6. Operate the engine for 15 to 20 minutes. Refer to Operation and Maintenance Manual, "Starting the Engine" for the correct procedure.
7. Stop the engine. Refer to Operation and Maintenance Manual, "Stopping the Engine" for the correct procedure.

Maintenance Section  
Belts - Inspect/Adjust/Replace

8. Isolate the electrical supply to the engine. Remove the guards.
9. Loosen bolts (5) and loosen the locknut (4).
10. Rotate the rod (3) to achieve a final tension of 62 N (14 lb). The total deflection should not exceed 16 mm (0.63 inch).
11. Tighten the locknut (4) to a torque of 120 N·m (88.5 lb ft). Tighten bolts (5) securely.
12. Restore the electrical supply to the engine. Install the guards.

i07212752

## Belts - Inspect/Adjust/Replace

### Inspect

To maximize the engine performance, inspect the belts for wear and for cracking. Replace belts that are worn or damaged.

To check accurately the belt tension, a suitable gauge should be used.

1. Isolate the electrical supply to the engine.

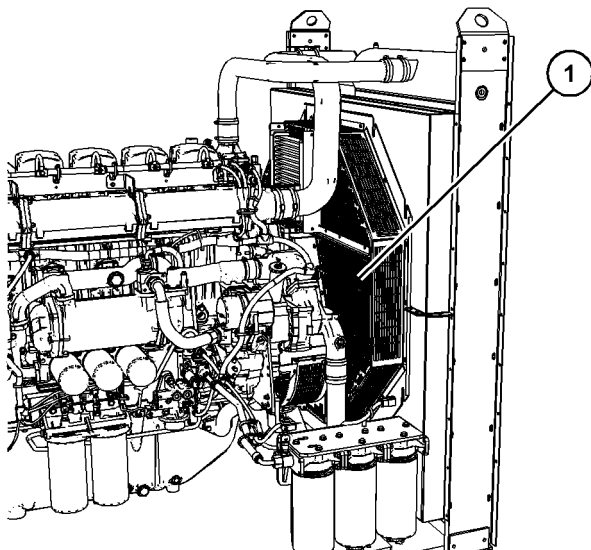

Illustration 33

g06253683

Typical example

2. Visibly inspect fan guards for wear or damage. Repair as necessary. Remove the fan guards (1).

3. Inspect the belts for cracks, splits, glazing, grease, displacement of the cord and evidence of fluid contamination. If necessary, replace the belts, refer to "Replace" for more information.

### Adjust

1. Ensure that the electrical supply to the engine is isolated.
2. Using a suitable belt tensioning tool, check the tension of the fan belts. The belt tension should be checked in the middle point between the two pulleys.

- New belt tension should be set to 49 N (11. lb)
- Belt tension range should be from 31 N to 49 N (6.9 lb to 11 lb)
- Belt deflection should be 4.2 mm (0.165 inch)

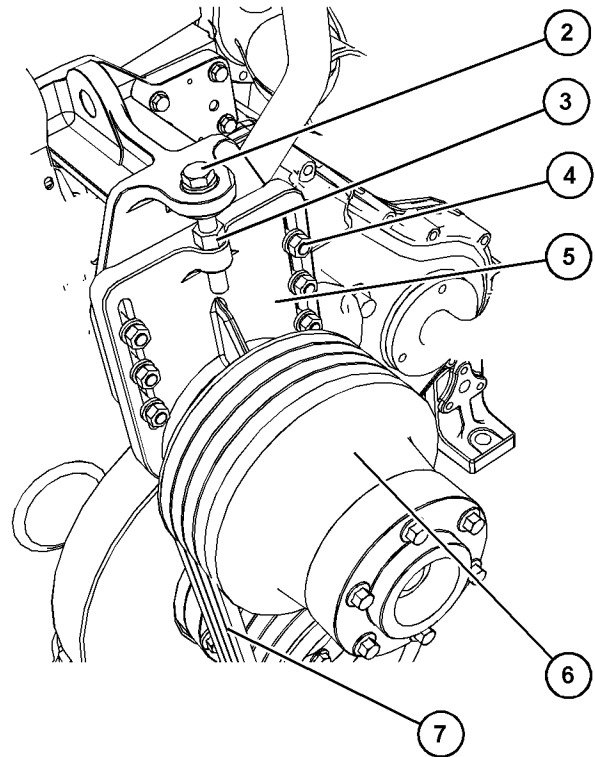

Illustration 34

g06079895

3. Each belt must be checked.
4. Loosen nuts (4) on fan adjuster plate (5). Loosen lock nut (3).
5. Turning bolt (2) counter-clockwise will adjust fan pulley (6) and loosen the fan belts (7).



6. Turning bolt (2) clockwise will adjust fan pulley (6) and tighten the fan belts (7).
7. When the fan belts (7) are at the required tension, tighten nuts (4) to a torque of 85 N·m (62 lb ft). Then, tighten nut (3) securely.
8. Install guards (1) and restore electrical power to the engine.

## Replace

Refer to "Disassembly and Assembly Manual" V-Belts (Fan Drive V-Belts) - Remove and Install for more information.

i07212767

## Belts - Inspect/Adjust/Replace (Alternator Belt)

### Inspection

1. Isolate the electrical supply to the engine.

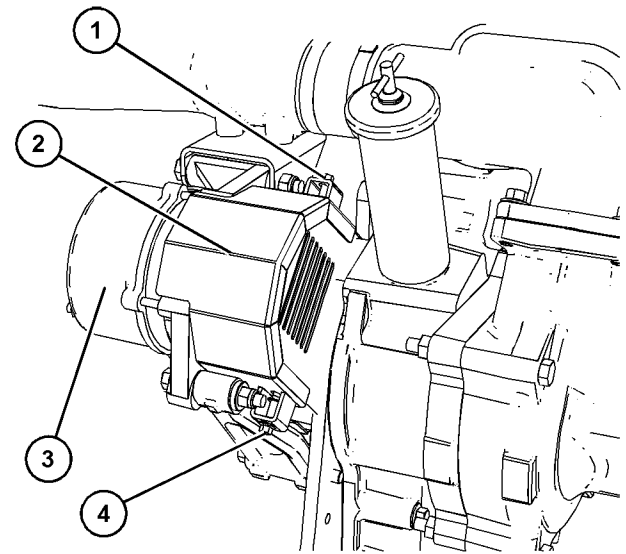

Illustration 35

g06253717

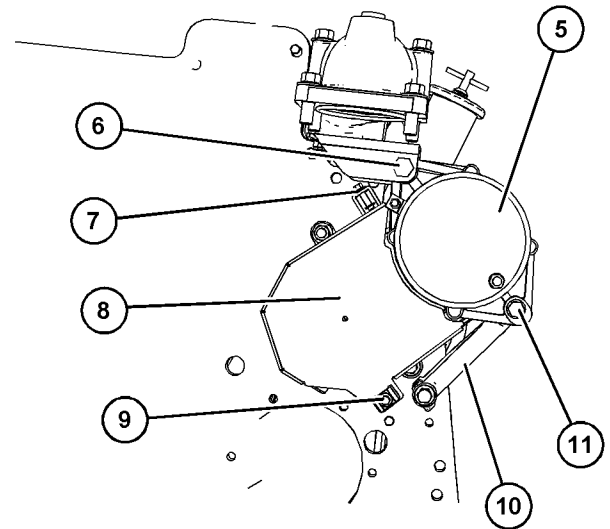

Illustration 36

g06253721

2. Remove bolt (1) and remove bolt (4). Remove top cover (2).
3. Remove bolt (7) and remove bolt (9). Remove lower cover (8).
4. Inspect the belt (13) for cracks. Inspect the belt for contamination. If necessary, replace the belt. Refer to "Replace the Belt" for more information.

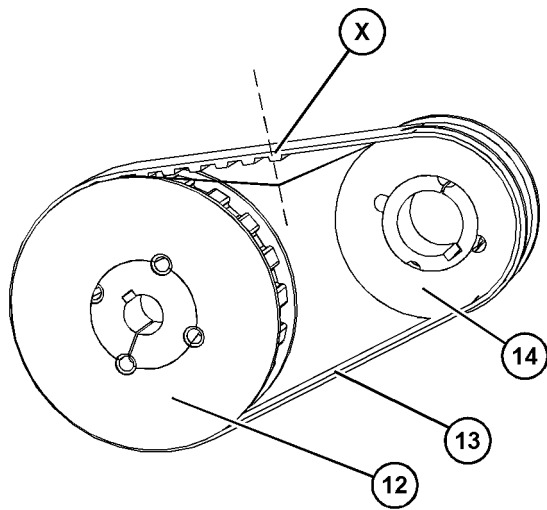

Illustration 37

g06253843

5. Apply 4.3 to 8.7 N (1 to 1.9 lb) of pressure at point (X).

The total deflection should not exceed 2.75 mm (0.10 inch).

Replace the belt if the total deflection exceeds 1.5 mm (0.06 inch). Refer to "Adjustment" for more information.

6. Install lower cover (8) and install top cover (2). Tighten bolt (7) and bolt (9) to a torque of 12 N·m (106 lb in). Tighten bolt (4) and bolt (1) to a torque of 12 N·m (106 lb in).

## Adjustment

The alternator belt is a toothed belt. The belt tension is not adjustable. The belt does not require a preload. Light tension will ensure that the belt is a snug fit on the pulleys.

## Replace the Belt

Isolate the electrical supply to the engine.

1. Refer to "Inspection" for removing the belt guard covers.
2. Loosen bolt (6) and loosen bolt (11). Push alternator (5) towards engine. If necessary, remove bolt (11) from link (10) to allow more moment.
3. Remove belt (13) and discard. Install new belt and ensure that the belt is located over pulley (12) and pulley (14). Ensure that new toothed belt is located into the pulley (12) and pulley (14).

4. If necessary, install bolt (11) and tension the new belt. Refer to "Inspection" for more information.
5. When required tension is correct, tighten bolt (11) to a torque of 47 N·m (34 lb ft). Tighten bolt (6) to a torque of 70 N·m (51 lb ft). Then, install the cover guards, refer to "Inspection" for more information.

When all checking of the belt or tensioning of the belt are completed and the all guards cover are installed, restore the electrical power.

i07228755

## Cooling System Coolant (ELC) - Change

### NOTICE

Care must be taken to ensure that fluids are contained during performance of inspection, maintenance, testing, adjusting and repair of the product. Be prepared to collect the fluid with suitable containers before opening any compartment or disassembling any component containing fluids.

Dispose of all fluids according to Local regulations and mandates.

### NOTICE

Keep all parts clean from contaminants.

Contaminants may cause rapid wear and shortened component life.

Clean the cooling system and flush the cooling system before the recommended maintenance interval if the following conditions exist:

- The engine overheats frequently.
- Foaming of the coolant is observed.
- The oil has entered the cooling system and the coolant is contaminated.
- The fuel has entered the cooling system and the coolant is contaminated.

**Note:** When the cooling system is cleaned, only clean water is needed when the Extended Life Coolant (ELC) is drained and replaced.

**Note:** Inspect the water pump and the water temperature regulator after the cooling system has been drained. This inspection is a good opportunity to replace the water pump, the water temperature regulator, and the hoses, if necessary.

## Drain

### WARNING

**Pressurized System: Hot coolant can cause serious burns. To open the cooling system filler cap, stop the engine and wait until the cooling system components are cool. Loosen the cooling system pressure cap slowly in order to relieve the pressure.**

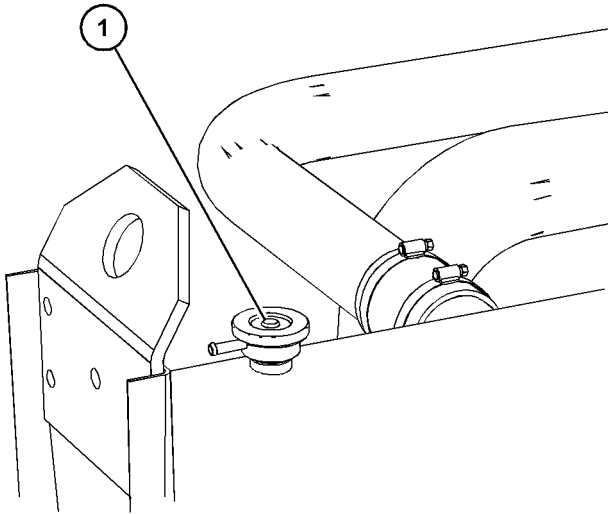

Illustration 38

g06258066

Typical example

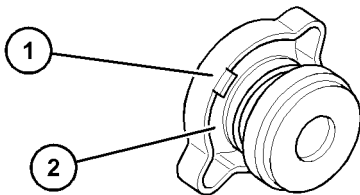

Illustration 39

g06258129

Typical example

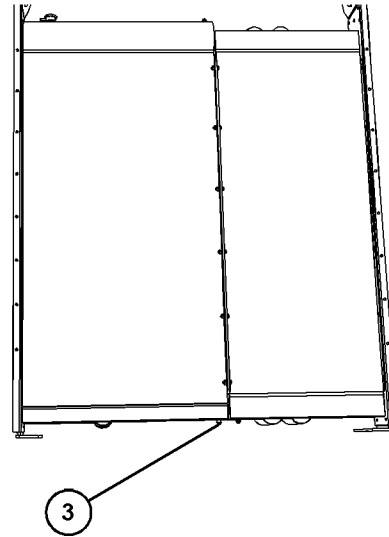

Illustration 40

g06258092

Typical example

1. Stop the engine and allow the engine to cool. Isolate the electrical supply to the engine. Loosen the cooling system filler cap (1) slowly to relieve any pressure. Remove the cooling system filler cap.
2. Clean the cooling system filler cap (1) and inspect the seal (2). If the seal is damaged, discard the old filler cap and install a new filler cap. If the seal is not damaged, use a suitable pressurizing pump to pressure test the filler cap. The correct pressure is stamped on the face of the filler cap. If the filler cap does not retain the correct pressure, replace the filler cap.
3. Open the drain cock or remove the drain plug (3) on the radiator .

Maintenance Section  
Cooling System Coolant (ELC) - Change

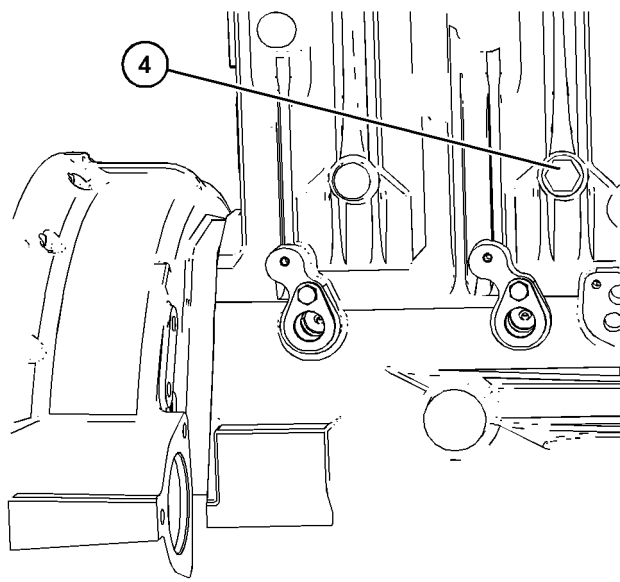

Illustration 41

g06258109

4. Remove the cylinder block drain plug (4).

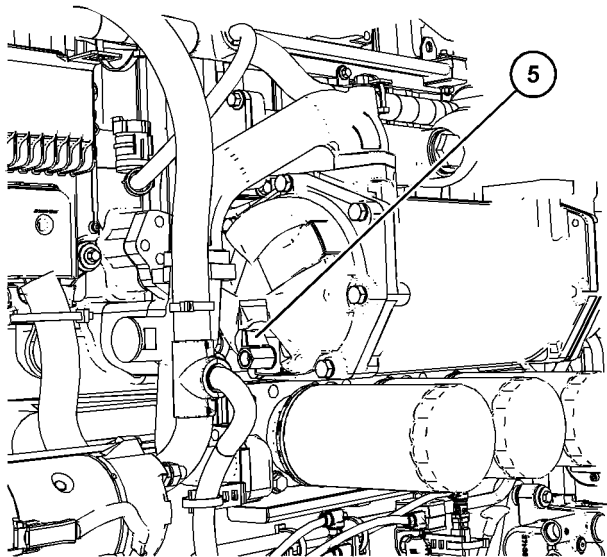

Illustration 42

g06258120

Typical example

5. Open the drain cock or remove the drain plug (5) in the oil cooler.
6. Allow the coolant to drain.

**NOTICE**

Dispose of used engine coolant or recycle. Various methods have been proposed to reclaim used coolant for reuse in engine cooling systems. The full distillation procedure is the only method acceptable by Perkins to reclaim the coolant.

For information regarding the disposal and the recycling of used coolant, consult your Perkins distributor.

**Flush**

1. Flush the cooling system with clean water to remove any debris.
2. Close the drain cock or install the drain plug (3) on the radiator. Close the drain cock or install the drain plug (4) in the cylinder block. Close the drain cocks or install the drain plug (5) in the oil cooler. Tighten the plugs securely.

**NOTICE**

Do not fill the cooling system faster than 5 L (1.3 US gal) per minute to avoid air locks.

Cooling system air locks may result in engine damage.

3. Fill the cooling system with clean water.  
Install the cooling system filler cap (1).
4. Install power to the engine. Start the engine. Operate the engine until the temperature reaches 49 °C to 66 °C (120 °F to 150 °F).
5. Stop the engine and allow the engine to cool. Isolate the electrical supply to the engine. Loosen the cooling system filler cap (1) slowly to relieve any pressure. Remove the cooling system filler cap. Open the drain cock or remove the drain plug (3) on the radiator. Open the drain cock or remove the drain plug (4) in the cylinder block. Open the drain cock or remove the drain plug (5) in the oil cooler. Allow the water to drain. Flush the cooling system with clean water.

**Fill**

1. Close the drain cock or install the drain plug (3) on the radiator. Close the drain cock or install the drain plug (4) in the cylinder block. Close the drain cock or install the drain plug (5) in the oil cooler.

**NOTICE**

Do not fill the cooling system faster than 5 L (1.3 US gal) per minute to avoid air locks.

Cooling system air locks may result in engine damage.

2. Fill the cooling system with Perkins (ELC). Refer to the Operation and Maintenance Manual, "Fluid Recommendations" topic (Maintenance Section) for more information on cooling system specifications.

**Note:** Ensure that the filler cap is installed before operating the engine.

3. Install power to the engine. Start the engine. Operate the engine to purge the air from the cavities of the engine block. Use the normal shutdown procedure to stop the engine.
4. Isolate the electrical supply to the engine. Remove the filler cap. Check that the coolant level is within 25 mm (1.0 inch) of the bottom of the filler pipe.
5. Install the cooling system filler cap.
6. Install power to the engine. Start the engine and operate the engine. Inspect the cooling system for leaks. Ensure that the cooling system operates at the correct temperature.

i02415245

## Cooling System Coolant Level - Check

### WARNING

**Pressurized System: Hot coolant can cause serious burns. To open the cooling system filler cap, stop the engine and wait until the cooling system components are cool. Loosen the cooling system pressure cap slowly in order to relieve the pressure.**

Check the coolant level when the engine is stopped and cool.

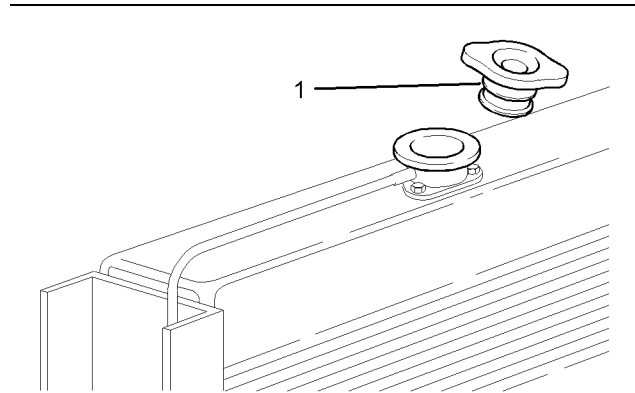

Illustration 43

g01211179

1. Remove the cooling system filler cap (1) slowly in order to relieve pressure.
2. Maintain the coolant level within 25 mm (1.0 inch) of the bottom of the filler pipe.

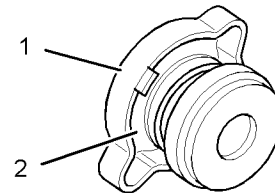

Illustration 44

g01239656

3. Clean the cooling system filler cap (1) and inspect the seal (2). If the seal is damaged, discard the old filler cap and install a new filler cap. If the seal is not damaged, use a suitable pressurizing pump in order to pressure test the filler cap. The correct pressure is stamped on the face of the filler cap. If the filler cap does not retain the correct pressure, replace the filler cap.

Install the cooling system filler cap.

4. Inspect the cooling system for leaks.

i06683212

## Crankshaft Vibration Damper - Inspect

Depending on the engine variant the engine can be equipped with one or two crankshaft vibration dampers. The crankshaft vibration damper limits the torsional vibration of the crankshaft. Damage to the crankshaft vibration damper can increase torsional vibrations. A damaged vibration damper can result in damage to the crankshaft and to other engine components.

Inspect the dampers for signs of damage, fluid leakage, or heat discoloration.

For more information on inspection the vibration dampers, refer to Systems Operation Testing and Adjusting, Vibration Damper.

i02151646

## Driven Equipment - Check

Refer to the OEM specifications for more information on the following maintenance recommendations for the driven equipment:

- Inspection
- Adjustment
- Lubrication
- Other maintenance recommendations

Perform any maintenance for the driven equipment which is recommended by the OEM.

i06683210

## Engine - Clean

### WARNING

**Personal injury or death can result from high voltage.**

**Moisture can create paths of electrical conductivity.**

**Make sure that the electrical system is OFF. Lock out the starting controls and tag the controls "DO NOT OPERATE" .**

#### NOTICE

Accumulated grease and oil on an engine is a fire hazard. Keep the engine clean. Remove debris and fluid spills whenever a significant quantity accumulates on the engine.

#### NOTICE

Water or condensation can cause damage to generator components. Protect all electrical components from exposure to water.

#### NOTICE

Failure to protect some engine components from washing may make your engine warranty invalid. Allow the engine to cool for 1 hour before washing the engine.

Periodic cleaning of the engine is recommended. A clean engine provides the following benefits:

- Easy detection of fluid leaks
- Maximum heat transfer characteristics
- Ease of maintenance

**Note:** Caution must be used to prevent electrical components from being damaged by excessive water when the engine is cleaned. Pressure washers and steam cleaners should not be directed at any electrical connectors or the junction of cables into the rear of the connectors. Avoid electrical components such as the alternator, the starting motors, and the ECU.

Ensure that care is taken that the safety labels, emission label, and any information labels are not removed during engine cleaning.

i07214345

## Engine Air Cleaner Element - Replace

#### NOTICE

Never run the engine without an air cleaner element installed. Never run the engine with a damaged air cleaner element. Do not use air cleaner elements with damaged pleats, gaskets or seals. Dirt entering the engine causes premature wear and damage to engine components. Air cleaner elements help to prevent airborne debris from entering the air inlet.

#### NOTICE

Never service the air cleaner element with the engine running since this will allow dirt to enter the engine.

Renew the air filter elements if the service indicators are triggered. Refer to Operation and Maintenance Manual, "Engine Air cleaner Service Indicator - Inspect" for more information.

Some engines are equipped with air intake precleaners. Clean the precleaners before maintenance is performed on the air filters. When performing maintenance, ensure that dirt does not enter the housing of the air cleaner.

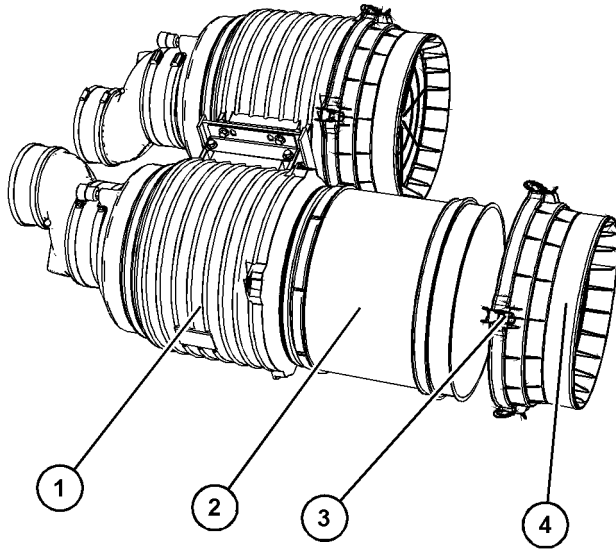

Illustration 45

g06254673

1. Isolate the electrical supply to the engine.
2. Ensure that the air cleaner body is clean and free from dirt. Remove clips (3) and remove end cover (4) from filter body (1).
3. Remove old element (2) and discard. Note the orientation of the filter element for installation.
4. Check the new filter element for damage before installing new filter element into filter body (1).
5. Ensure that end cover (4) is clean and free from dirt before installing end cover (4). Then, secure clips (3). The engine is equipped with 2 filter elements, when performing maintenance both filter elements must be changed.
6. Connect the electrical power to the engine.

i02415251

## Engine Air Cleaner Service Indicator - Inspect

### Service Indicator Check

Check the service indicators. Replace the air filter elements if one of service indicators has been triggered.

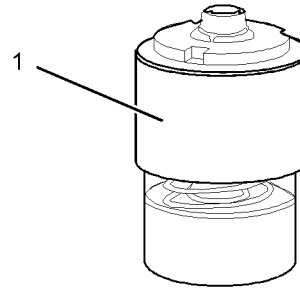

Illustration 46

g01242320

When the air filter element is in a serviceable condition, the center section of the service indicator (1) is clear.

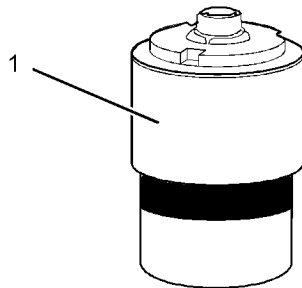

Illustration 47

g01242332

When the air filter element requires replacement, the center section of the service indicator (1) is red.

## Service Indicator Reset

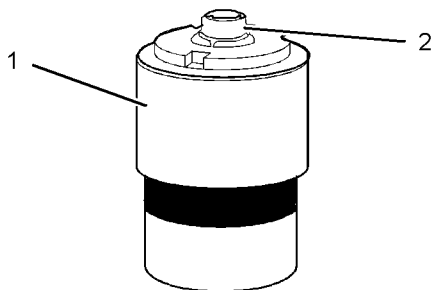

Illustration 48

g01242328

Once the service indicator has been triggered and when the air filter element has been replaced, the service indicator must be reset. In order to reset the service indicator (1), press the button (2).

If the service indicator does not reset easily, the service indicator should be replaced.

**Note:** The service indicator may need to be replaced frequently in environments that are severely dusty.

i07214352

## Engine Crankcase Breather - Clean

The breather has no filter element that needs to be replaced. The breather will only require cleaning.

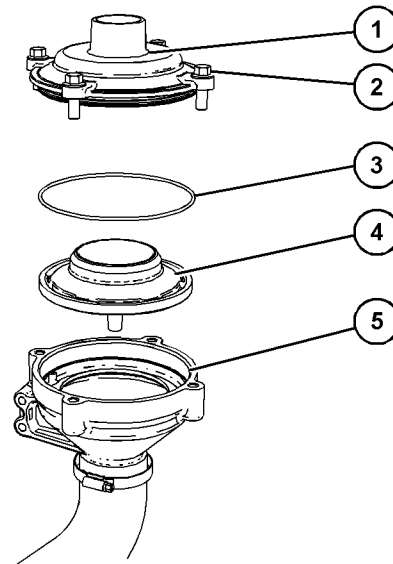

Illustration 49

g06009120

Typical example

1. Isolate the electrical supply to the engine.
2. Ensure that the outer casing of the breather is clean and free from dirt. Remove the bolts (2) and remove cover (1) from breather body (5).
3. Remove O ring seal (3) and discard.
4. Remove breather baffle (4) and clean the breather baffle, cover, and breather body.
5. Install cleaned breather baffle (4) into clean breather body (5). Install new O ring seal (3) onto cover (1) and install cover to breather body (5).
6. Install bolts (1) and tighten bolts to a torque of 50 N·m (36 lb ft). Install power to the engine.

i02415257

## Engine Mounts - Inspect

Misalignment of the engine and the driven equipment will cause extensive damage. Excessive vibration can lead to misalignment. Excessive vibration of the engine and the driven equipment can be caused by the following conditions:

- Improper mounting
- Loose bolts
- Deterioration of the isolators

Ensure that the mounting bolts are tightened to the correct torque.



Ensure that the isolators are free of oil and contamination. Inspect the isolators for deterioration. Ensure that the bolts for the isolators are tightened to the correct torque.

Replace any isolator that shows deterioration. For more information, see the literature that is provided by the OEM of the isolators.

i07214750

## Engine Oil Level - Check

### WARNING

Hot oil and hot components can cause personal injury. Do not allow hot oil or hot components to contact the skin.

### NOTICE

Perform this maintenance with the engine stopped.

**Note:** After the engine has been switched OFF, wait for 10 minutes to allow the engine oil to drain to the oil pan. Then check the oil level.

### NOTICE

Operating your engine when the oil level is above the "Max" mark could cause your crankshaft to dip into the oil. The air bubbles created from the crankshaft dipping into the oil reduces the oils lubricating characteristics and could result in the loss of power.

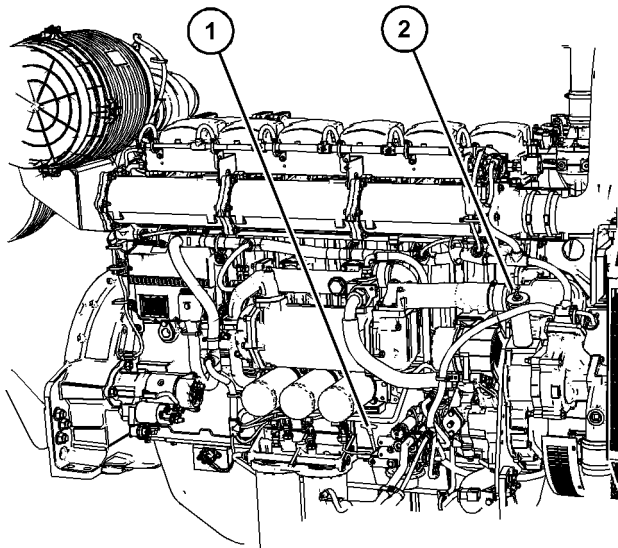

Illustration 50

g06255129

Typical example

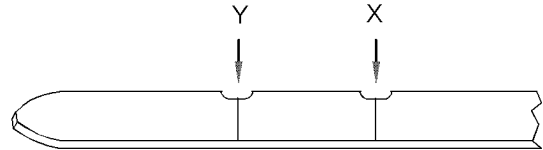

Illustration 51

g01165836

(Y) "Min" mark. (X) "Max" mark.

1. Maintain the oil level between the "Min" mark (Y) and the "Max" mark (X) on the engine oil level gauge (1). Do not fill the oil pan above the "Max" mark (X).
2. If necessary, remove the oil filler cap (2) and add oil. Clean the oil filler cap. Install the oil filler cap.

i03883009

## Engine Oil Pump - Inspect

A failed engine oil pump may result in a seizure of the crankshaft.

Remove the engine oil pump and disassemble the engine oil pump. Replace any components that are worn or damaged. Alternatively, replace the engine oil pump.

i07426639

## Engine Oil Sample - Obtain

The condition of the engine lubricating oil should be checked at regular intervals as part of the preventive maintenance program.

### Initiating an Oil analysis Program

#### The First 300 Hours

Oil analysis in the first 300 hours will show higher levels of iron and copper than acceptable parameters. As the engine continues to operate, the levels will drop within the specified parameters.

## Every 150 Hours

An oil sample should be obtained at 150 hour intervals.

A trend can be established by analyzing the results of the oil sampling. Each individual operator can develop a service program for the engine.

**Note:** Perkins Engines Stafford must agree to the maintenance schedule.

## Obtain the Sample and the Analysis

### WARNING

**Hot oil and hot components can cause personal injury. Do not allow hot oil or hot components to contact the skin.**

The oil sample must be taken from the mean level in the engine oil pan. Do not take an oil sample from the drain plug.

To help obtain the most accurate analysis, record the following information before an oil sample is taken:

- The date of the sample
- Engine model
- Engine number
- Service hours on the engine
- The number of hours that have accumulated since the last oil change
- The amount of oil that has been added since the last oil change

Ensure that the container for the sample is clean and dry. Also ensure that the container for the sample is clearly labeled.

To ensure that the sample is representative of the oil in the crankcase, obtain a warm, well mixed oil sample.

To avoid contamination of the oil samples, the tools and the supplies that are used for obtaining oil samples must be clean.

The sample can be checked for the following: the quality of the oil, the existence of any coolant in the oil, the existence of any ferrous metal particles in the oil and the existence of any nonferrous metal particles in the oil.

i07425870

## Engine Oil and Filter - Change

### WARNING

**Hot oil and hot components can cause personal injury. Do not allow hot oil or hot components to contact the skin.**

### NOTICE

Care must be taken to ensure that fluids are contained during performance of inspection, maintenance, testing, adjusting and repair of the product. Be prepared to collect the fluid with suitable containers before opening any compartment or disassembling any component containing fluids.

Dispose of all fluids according to local regulations and mandates.

### NOTICE

Keep all parts clean from contaminants.

Contaminants may cause rapid wear and shortened component life.

Do not drain the engine lubricating oil when the engine is cold. As the engine lubricating oil cools, suspended waste particles settle on the bottom of the oil pan. The waste particles are not removed with draining cold oil. Drain the oil pan with the engine stopped. Drain the oil pan with the oil warm. This draining method allows the waste particles that are suspended in the oil to be drained properly.

Failure to follow this recommended procedure will cause the waste particles to be recirculated through the engine lubrication system with the new oil.

## Oil and Filter Change Intervals

The standard engine oil and filter change period is 300 hours. There are several other factors that can alter the standard engine oil and filter change of 300 hours.

- If the engine is using engine oil analysis to determine oil and filter change period.
- The engine is working in a severe service environment/Load Factor
- Infrequent operation of the engine

Refer to this Operation and Maintenance Manual, "Severe Service Application" for more information on reducing the engine oil and filter change period. For severe service applications the recommended oil and filter change period is 150 hours.

If the engine is operated in severe service conditions, Perkins recommends the use of engine oil sampling. Refer to this Operation and Maintenance Manual, Engine Oil sample - Obtain for more information.

If the engine is operated infrequently less than 300 hours in a 12-month period, then the engine oil and filter change should be conducted yearly.

## Drain the Engine Lubricating Oil

Operate the engine so that the lubricating oil is warm, then stop the engine. Isolate the electrical power to the starter.

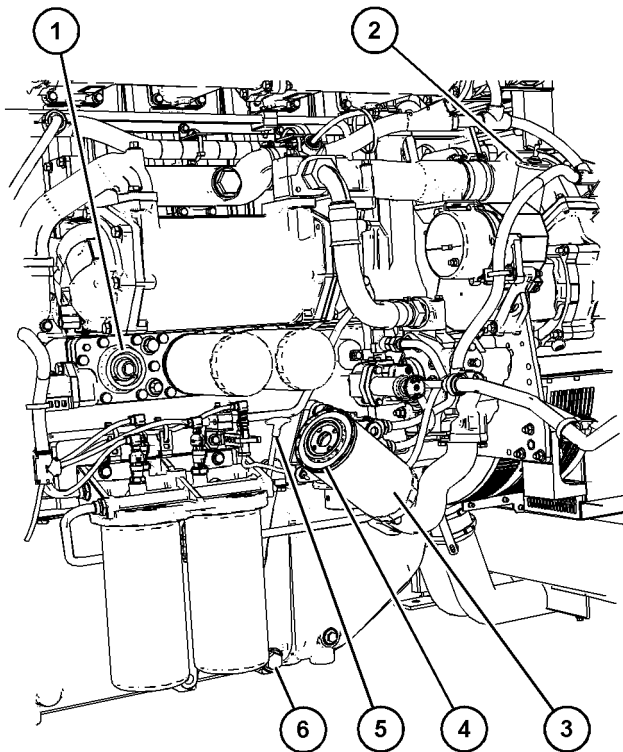

Illustration 52

g06327798

Typical example

1. Place a suitable container below the engine oil pan. Remove the drain plug (6). Allow the engine oil to drain.

**Note:** Ensure that the vessel that will be used is large enough to collect the waste oil.

2. Remove the sealing washer from the drain plug (6). Discard the sealing washer.

3. Install a new sealing washer to the drain plug (6). Install the drain plug to the engine oil pan. Tighten the plug to a torque of 68 N·m (50 lb ft).

## Replace the Oil Filter

Table 17

Required Tools			
Tool	Part Number	Part Name	Qty
A	-	Strap Wrench	1

**Note:** Ensure that all 3 oil filters are changed as a set.

1. Use Tooling (A) to remove the oil filters (3)
2. Ensure that the sealing face of the filter base (1) is clean and free from dirt.
3. Lubricate the O rings (4) with clean engine oil. Install the new oil filter (3).

**Note:** Apply hand pressure only to tighten the oil filters.

4. Spin on the oil filter until the O ring (4) contacts the sealing surface (1). Then rotate the oil filter  $\frac{3}{4}$  of a full turn. After all the oil filters have been replaced, fill the oil pan.

## Fill the Oil Pan

Refer to Operation and Maintenance Manual, "Fluid Recommendations" for information on suitable oils.

1. Remove the oil filler cap (2).
2. Fill the oil pan with the correct amount of new engine lubricating oil and install the filler cap. Refer to Operation and Maintenance Manual, "Refill Capacities" for more information. Restore electrical power to the starter.

### NOTICE

If equipped with an auxiliary oil filter system or a remote filter system, follow the OEM or the filter manufacturer's recommendations. Under-filling or over filling the crankcase with oil can cause engine damage.

**Note:** Before starting the engine, the engine oil system must be primed. Refer to Operation and Maintenance Manual, "Before Starting Engine" for the procedure to prime the engine oil system.

3. Start the engine and run the engine for 2 minutes. Perform this procedure to ensure that the lubrication system has oil and that the oil filters are filled. Inspect the oil filters for oil leaks.

4. Stop the engine and allow the oil to drain back to the oil pan for a minimum of 10 minutes.

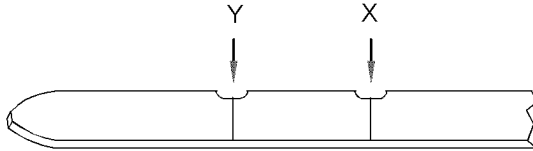

Illustration 53 g01165836  
 (Y) "Min" mark. (X) "Max" mark.

5. Remove the engine oil level gauge (5) to check the oil level. Maintain the oil level between the "MIN" and "MAX" marks on the engine oil level gauge.

i02461963

## Engine Protective Devices - Check

Alarms and shutoffs must function properly. Alarms provide timely warning to the operator. Shutoffs help to prevent damage to the engine. It is impossible to determine if the engine protective devices are in good working order during normal operation. Malfunctions must be simulated in order to test the engine protective devices.

A calibration check of the engine protective devices will ensure that the alarms and shutoffs activate at the setpoints. Ensure that the engine protective devices are functioning properly.

### NOTICE

During testing, abnormal operating conditions must be simulated.

The tests must be performed correctly in order to prevent possible damage to the engine.

To prevent damage to the engine, only authorized service personnel or your Perkins dealer should perform the tests.

## Visual Inspection

Visually check the condition of all gauges, sensors and wiring. Look for wiring and components that are loose, broken, or damaged. Damaged wiring or components should be repaired or replaced immediately.

i03783789

## Engine Valve Lash - Inspect/Adjust (Valves and Valve Bridges)

### NOTICE

Only qualified service personnel should perform this maintenance. Refer to the Service Manual or your authorized Perkins dealer or your Perkins distributor for the complete valve lash adjustment procedure.

Operation of Perkins engines with incorrect valve lash can reduce engine efficiency, and also reduce engine component life.

### WARNING

Ensure that the engine cannot be started while this maintenance is being performed. To help prevent possible injury, do not use the starting motor to turn the flywheel.

Hot engine components can cause burns. Allow additional time for the engine to cool before measuring/adjusting valve lash clearance.

**Note: The valve bridges must be equalized before the valve lash is adjusted.**

Refer to Systems Operation, Testing and Adjusting, "Valve Lash - Adjust" for the correct procedure.

i07395689

## Fan Drive Pulley - Check (4008-30 Engine Only)

1. Isolate the electrical supply to the engine.

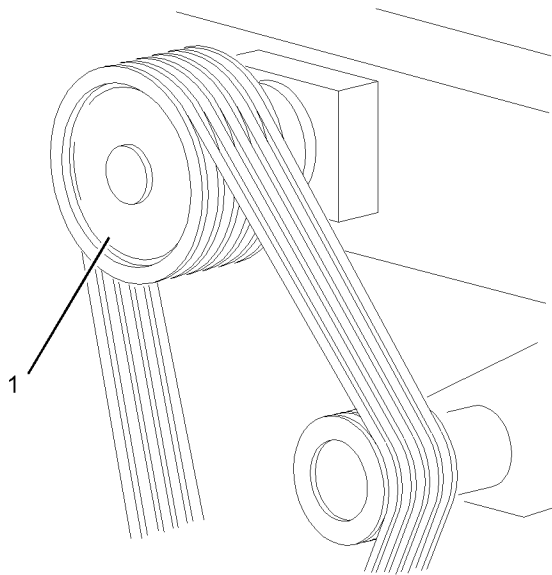

Illustration 54

g01238304

Typical example

2. Remove the guards (not shown) to gain access to the fan drive pulley (1).

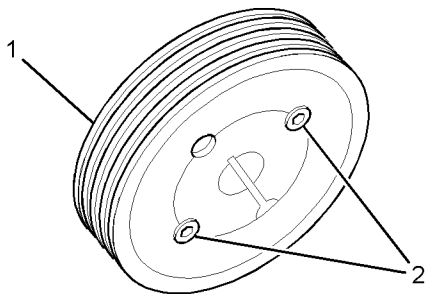

Illustration 55

g01238305

3. Tighten the grub screws (2) to a torque of 90 N·m (66 lb ft).
4. Install the guards (not shown).
5. Restore the electrical supply to the engine.

i07426644

## Fuel Injector - Inspect/Adjust

**Note:** Perform this procedure when the engine valve lash is inspected.

### NOTICE

The camshafts must be correctly timed with the crankshaft before an adjustment of the lash for the fuel injector is made.

Inspect the adjustment of the lash for the fuel injector according to the Testing and Adjusting, "Fuel Injector Adjustment". Adjust the lash for the fuel injector, if necessary.

i07398052

## Fuel Injector - Replace

### ⚠ WARNING

Fuel leaked or spilled onto hot surfaces or electrical components can cause a fire.

### NOTICE

Do not allow dirt to enter the fuel system. Thoroughly clean the area around a fuel system component that will be disconnected. Fit a suitable cover over any disconnected fuel system components.

### NOTICE

If a fuel injector is suspected of operating outside of normal parameters it should be removed by a qualified technician. The suspect fuel injector should be taken to an authorised agent for inspection.

Refer to the appropriate Disassembly and Assembly manual for the removal and installation procedure.

i08037161

## Fuel System - Prime

If air enters the fuel system, the air must be purged from the fuel system before the engine can be started. Air can enter the fuel system when the following events occur:

- The fuel day tank is empty or partially drained
- The low-pressure fuel lines are disconnected
- A leak exists in the low-pressure fuel system
- The fuel filter has been replaced

Use the following procedures to remove air from the fuel system.

**NOTICE**

Do not crank the engine continuously for more than 30 seconds. Allow the starting motor to cool for two minutes before cranking the engine again.

i07217040

## Fuel System Primary Filter - Replace

### **⚠ WARNING**

Fuel leaked or spilled onto hot surfaces or electrical components can cause a fire. To help prevent possible injury, turn the start switch off when changing fuel filters or water separator elements. Clean up fuel spills immediately.

**NOTICE**

Ensure that the engine is stopped and the battery is isolated, before any servicing or repair is performed.

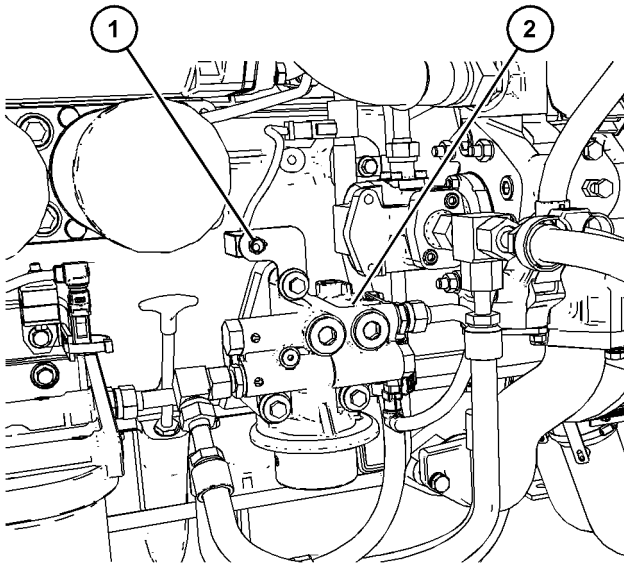

Illustration 56

g06329228

- (1) Fuel priming switch  
 (2) Fuel priming pump

1. The fuel system can be primed from the key switch or from a remote mounted switch (1).
2. Ensure that any fuel isolation switches to the engine are in the open position to allow the correct fuel flow.
3. Turn the fuel priming switch (1) to the ON position. Hold the fuel priming switch in the ON position for 2 minutes.
4. Attempt to start the engine.
5. If the engine cannot be started, or if the engine runs rough, or if the engine misfires, or if the engine smoke, stop the engine. Repeat Step 3 through Step 5.

The fuel system can also be primed by using the key switch. Turn the key to the ON position for 2 minutes. After 2 minutes the fuel system should be primed. If necessary, by cycling the key switch the system will prime again for 2 minutes.

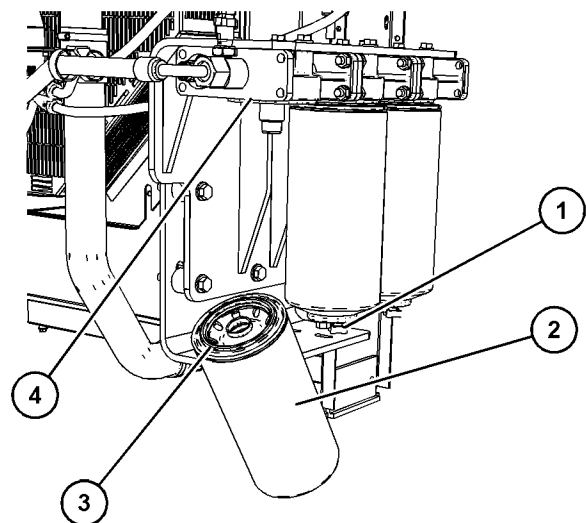

Illustration 57

g06255626

### Typical example

1. Isolate the fuel supply to the engine.
2. Place a suitable container under the fuel filter to catch any fuel that might spill. Clean up any spilled fuel immediately. The engine is equipped with 3 primary fuel filters all the primary filter must be replaced.
3. Clean the outside of the fuel filters. Open the drain valve (1) on all 3 primary fuel filters and allow the fuel to drain.
4. Use a suitable strap wrench remove the primary fuel filter (2) and discard.

5. Ensure that the sealing surface (4) is clean the free from dirt. Lubricate the O ring seal (3) on the new primary fuel filter with clean fuel oil.
6. Install the new primary fuel filter using hand pressure only. When the O ring seal (3) contacts the sealing surface (4), rotate the primary fuel filter 1 full turn.
7. Repeat Steps 4 to Step 6 for the other primary fuel filters.
8. When all 3 primary fuel filters have been replaced, the secondary fuel filters must be replaced. Refer to "Operation and Maintenance Manual" Secondary Fuel Filter- Replace for more information.

i07217113

## Fuel System Primary Filter/ Water Separator - Drain

### WARNING

Fuel leaked or spilled onto hot surfaces or electrical components can cause a fire. To help prevent possible injury, turn the start switch off when changing fuel filters or water separator elements. Clean up fuel spills immediately.

#### NOTICE

Ensure that the engine is stopped before any servicing or repair is performed.

#### NOTICE

The water separator can be under suction during normal engine operation. Ensure that the drain valve is tightened securely to help prevent air from entering the fuel system.

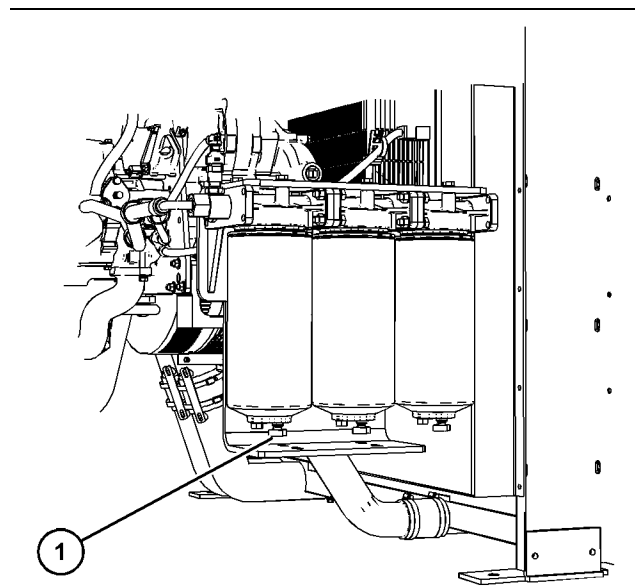

Illustration 58

g06255677

Typical example

1. Place a suitable container under the water separator to catch any fuel that might spill. Clean up any spilled fuel immediately.
2. Loosen the drain plug (1). Allow the fluid to drain into the container until clean fuel can be seen.
3. Tighten the drain plug (1). Use hand pressure only.
4. Ensure that all 3 primary water separators are serviced. Dispose of the drained fluid in accordance with local regulations.

i07218219

## Fuel System Secondary Filter - Replace

### WARNING

Fuel leaked or spilled onto hot surfaces or electrical components can cause a fire. To help prevent possible injury, turn the start switch off when changing fuel filters or water separator elements. Clean up fuel spills immediately.

#### NOTICE

Ensure that the engine is stopped and the battery is isolated, before any servicing or repair is performed.

i02335436

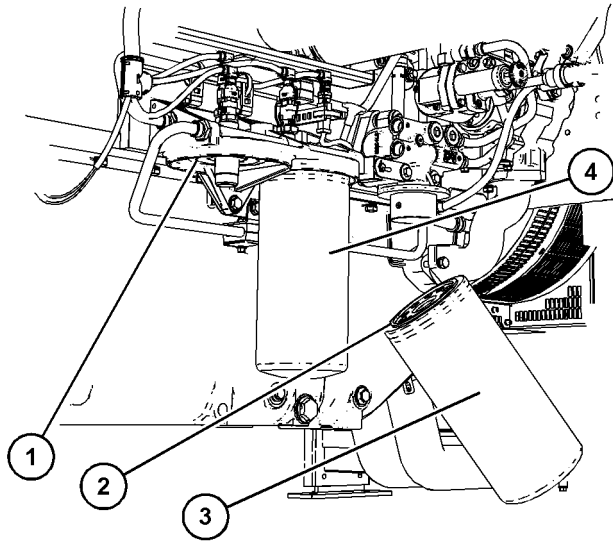

Illustration 59

g06309402

#### Typical example

1. Ensure that the fuel supply valve is in the OFF position.
2. Clean the outside of the secondary and tertiary fuel filters.
3. Use a suitable strap wrench to remove the tertiary fuel filter (3) and discard the old tertiary fuel filter.
4. Lubricate the O ring seal (2) on the new tertiary fuel filter with clean engine oil. Ensure that the sealing surface (1) is clean and free from dirt.
5. Installed the new fuel filter by hand only. When the O ring seal (2) contacts the sealing surface (1), rotate the tertiary fuel filter 1 full turn.
6. Repeat Step 3 through Step 5 for the secondary filter (4).
7. Remove the container and dispose of the fuel in accordance with local regulations.
8. Restore the fuel supply to the engine.
9. Prime the fuel system. Refer to the Operation and Maintenance Manual, "Fuel System - Prime" for more information.
10. Start the engine and run the engine. Check the fuel system for leaks.

## Fuel Tank Water and Sediment - Drain

### NOTICE

Care must be taken to ensure that fluids are contained during performance of inspection, maintenance, testing, adjusting and repair of the product. Be prepared to collect the fluid with suitable containers before opening any compartment or disassembling any component containing fluids.

Dispose of all fluids according to local regulations and mandates.

## Fuel Tank

Fuel quality is critical to the performance and to the service life of the engine. Water in the fuel can cause excessive wear to the fuel system.

Water can be introduced into the fuel tank when the fuel tank is being filled.

Condensation occurs during the heating and cooling of fuel. The condensation occurs as the fuel passes through the fuel system and the fuel returns to the fuel tank. This causes water to accumulate in fuel tanks. Draining the fuel tank regularly and obtaining fuel from reliable sources can help to eliminate water in the fuel.

## Drain the Water and the Sediment

Fuel tanks should contain some provision for draining water and draining sediment from the bottom of the fuel tanks.

Open the drain valve on the bottom of the fuel tank in order to drain the water and the sediment. Close the drain valve.

Check the fuel daily. Allow five minutes after the fuel tank has been filled before draining water and sediment from the fuel tank.

Fill the fuel tank after operating the engine in order to drive out moist air. This will help prevent condensation. Do not fill the tank to the top. The fuel expands as the fuel gets warm. The tank may overflow.



Some fuel tanks use supply pipes that allow water and sediment to settle below the end of the fuel supply pipe. Some fuel tanks use supply lines that take fuel directly from the bottom of the tank. If the engine is equipped with this system, regular maintenance of the fuel system filter is important.

## Fuel Storage Tanks

Drain the water and the sediment from the fuel storage tank at the following intervals:

- Weekly
- Service intervals
- Refill of the tank

This will help prevent water or sediment from being pumped from the storage tank into the engine fuel tank.

If a bulk storage tank has been refilled or moved recently, allow adequate time for the sediment to settle before filling the engine fuel tank. Internal baffles in the bulk storage tank will also help trap sediment. Filtering fuel that is pumped from the storage tank helps to ensure the quality of the fuel. When possible, water separators should be used.

i07426322

## Fuel Transfer Pump (Lift Pump) - Inspect

Visually inspect the lift pump for leaks. The lift pump is not a serviceable item. Replace a lift pump that is faulty. Replace a lift pump that leaks.

i07458957

## Hoses and Clamps - Inspect/Replace

### WARNING

**Contact with high pressure fuel may cause fluid penetration and burn hazards. High pressure fuel spray may cause a fire hazard. Failure to follow these inspection, maintenance and service instructions may cause personal injury or death.**

If you inspect the engine in operation, always use the proper inspection procedure to avoid a fluid penetration hazard. Refer to Operation and Maintenance Manual, "General hazard Information".

Inspect all hoses for leaks that are caused by the following conditions:

- Cracking
- Softness
- Loose clamps

Replace hoses that are cracked or soft. Tighten any loose clamps.

Check for the following conditions:

- End fittings that are damaged or leaking
- Outer covering that is chafed or cut
- Exposed wire that is used for reinforcement
- Outer covering that is ballooning locally
- Flexible part of the hose that is kinked or crushed
- Armoring that is embedded in the outer covering

A constant torque hose clamp can be used in place of any standard hose clamp. Ensure that the constant torque hose clamp is the same size as the standard clamp.

Due to extreme temperature changes, the hose will harden. Hardening of the hoses will cause hose clamps to loosen. This action can result in leaks. A constant torque hose clamp will help to prevent loose hose clamps.

Each installation application can be different. The differences depend on the following factors:

- Type of hose
- Type of fitting material
- Anticipated expansion and contraction of the hose
- Anticipated expansion and contraction of the fittings

## Replace the Hoses and the Clamps

Refer to the OEM information for further information on removing and replacing fuel hoses (if equipped).

The coolant system and the hoses for the coolant system are not usually supplied by Perkins. The following text describes a typical method of replacing coolant hoses. Refer to the OEM information for further information on the coolant system and the hoses for the coolant system.

 **WARNING**

**Pressurized System: Hot coolant can cause serious burns. To open the cooling system filler cap, stop the engine and wait until the cooling system components are cool. Loosen the cooling system pressure cap slowly in order to relieve the pressure.**

---

1. Stop the engine. Allow the engine to cool.
2. Loosen the cooling system filler cap slowly to relieve any pressure. Remove the cooling system filler cap.

**Note:** Drain the coolant into a suitable, clean container. The coolant can be reused.

3. Drain the coolant from the cooling system to a level that is below the hose that is being replaced.
4. Remove the hose clamps.
5. Disconnect the old hose.
6. Replace the old hose with a new hose.
7. Install the hose clamps with a torque wrench.

**Note:** For the correct coolant, see this Operation and Maintenance Manual, "Fluid Recommendations".

8. Refill the cooling system. Refer to the OEM information for further information on refilling the cooling system.
9. Clean the cooling system filler cap. Inspect the cooling system filler cap seals. Replace the cooling system filler cap if the seals are damaged. Install the cooling system filler cap.

10. Start the engine. Inspect the cooling system for leaks.

## Clamps and V-Band Locations

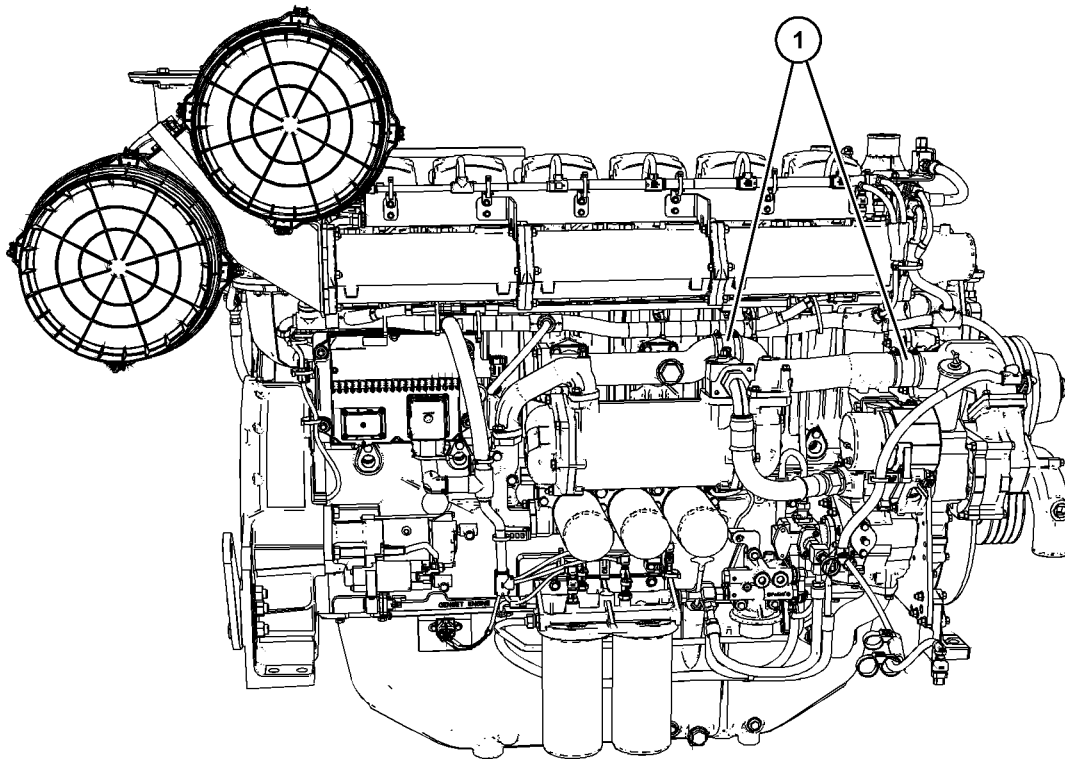

Illustration 60

g06329247

(1) Clamp torque 7 N·m (62 lb in)

Maintenance Section  
Hoses and Clamps - Inspect/Replace

---

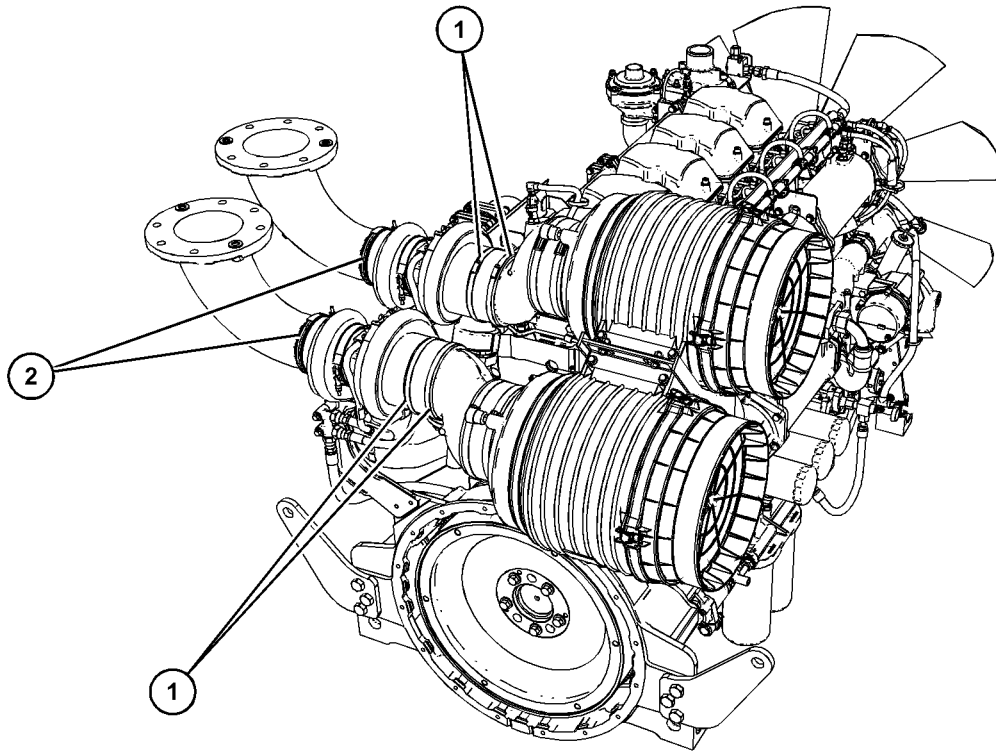

Illustration 61

g06329566

(1) Clamp torque 7 N·m (62 lb in)

(2) Clamp torque 9 N·m (79 lb in)

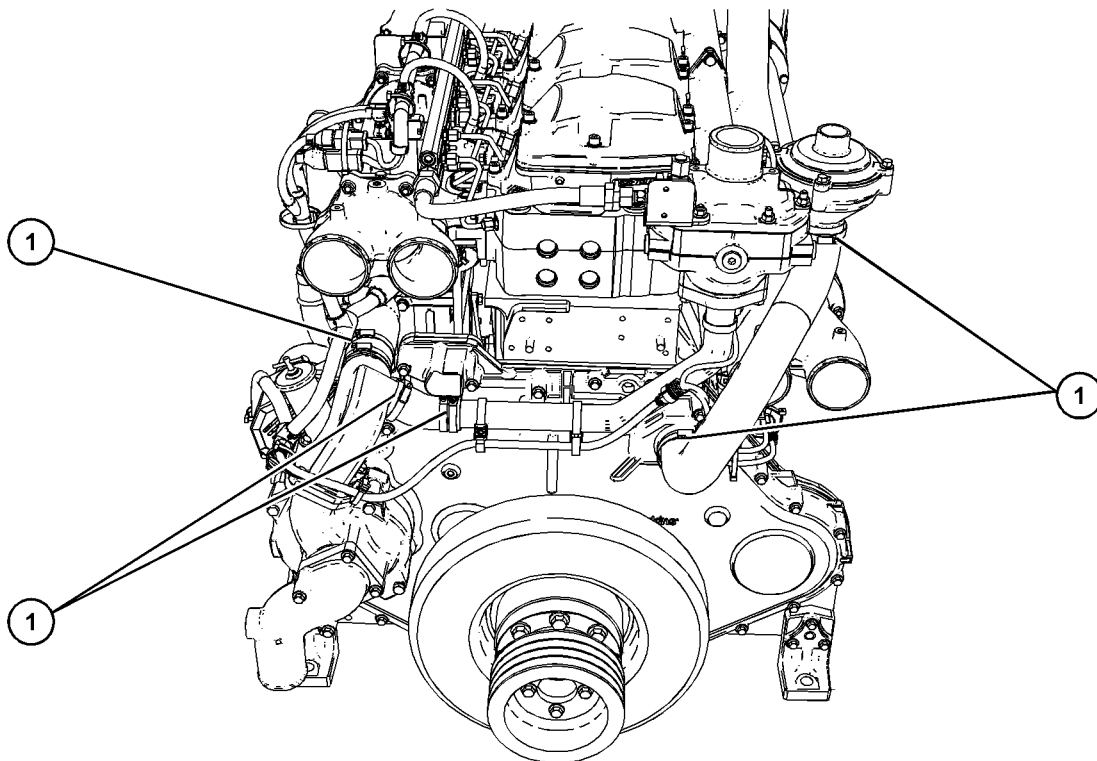

Illustration 62

g06329596

(1) Clamp torque 7 N·m (62 lb in)

## Clamps and V-Band Clamp Torques

Table 18

Clamps and V-band Clamp Torques	
Clamp	Torque
1	7 N·m (62 lb in)
2	9 N·m (79 lb in)

i06530584

## Overhaul (Major)

### Scheduling a Major Overhaul

The need for a major overhaul is determined by several factors:

- An increase of oil consumption
- An increase of crankcase blowby
- A decrease and variation of cylinder compression

Other factors must also be considered for determining a major overhaul:

- The service hours of the engine
- The wear metal analysis of the lube oil
- An increase in the levels of noise and vibration

An increase of wear metals in the lube oil indicates that the bearings and the surfaces that wear may need to be serviced. An increase in the levels of noise and vibration indicates that rotating parts require service.

**Note:** Oil analysis can indicate a decrease of wear metals in the lube oil. The cylinder liners may be worn so that polishing of the bore occurs. Also, the increased use of lube oil will dilute the wear metals.

Monitor the engine as the engine accumulates service hours. Consult Perkins Engines Stafford about scheduling a major overhaul.

**Note:** The driven equipment may also require service when the engine is overhauled. Refer to the literature that is provided by the OEM of the driven equipment.

## Major Overhaul Information

During a major overhaul, all the bearings, seals, joints, and components that wear should be disassembled. The parts should be cleaned. The parts should then be inspected. If necessary, the parts should be replaced. The crankshaft should be inspected and measured for wear. The crankshaft may require regrinding. Alternatively, the crankshaft may be replaced.

### Inspecting Components

Inspect the following components during a major overhaul.

- Radiator and system
- Camshaft
- Camshaft followers
- Connecting rods and bearings
- Crankshaft and bearings
- Gear train
- Inlet air piping
- Oil cooler
- Pistons and rings
- Cylinder liners
- Cylinder heads
- Inlet and exhaust valves

Replace the crankshaft vibration dampers.

i07426646

## Overhaul (Top End)

### Scheduling a Top End Overhaul

Top end overhauls should be scheduled according to the recession of the valve stems. This measurement provides an accurate indication of the rate of valve wear. This measurement can be used to predict when a cylinder head requires replacement.

**Note:** Generally, cylinder heads wear out at different rates. Sometimes, servicing the cylinder heads at different times may be the most economic decision. This action depends on the valve stem projection of the individual cylinders. However, this decision must include the costs of additional downtime that is caused by this procedure. Perform an economic analysis to determine if cylinder heads should be serviced as a group or divided into smaller groups.

### Top End Overhaul Information

A top end overhaul involves servicing the cylinder heads. During a top end overhaul, one piston should be removed. Inspect the piston, piston rings, and the cylinder liner. The condition of these components will determine the period of the major overhaul. Refer to Service Manual for more information.

### Monitoring Valve Seat Wear

Every 2000 service hours record the valve lash. The monitoring of the valve seat wear should be carried out before any adjustment of the valve lash.

1. Remove the rocker covers.
2. Refer to Systems Operation, Testing and Adjusting, "Valve Lash - Adjust".
3. On all engine cylinders, record the clearance before any adjustments are made.
4. Set the valve bridges.
5. Adjust the valve lash to 0.4 mm (0.016 inch).

The recorded values can be used to identify any excessive valve seat wear on individual valves. The recorded values can be used to schedule a top end overhaul.

An example of recorded valve lash

Table 19

Hours	Recorded clearances on A1 cylinder		Total valve wear	
	Inlet	Exhaust	Inlet	Exhaust
2000	0.35	0.35	0.05	0.05
4000	0.25	0.3	0.35	0.3
6000	0.25	0.3	0.65	0.45

After 6000 hours running, the valve seat wear on the inlet is 0.65 mm (0.026 inch) and the exhaust is 0.45 mm (0.018 inch).

**Note:** Maximum permitted valve seat wear is 1.5 mm (0.05906 inch).

In this example, the valves are still serviceable after 4500 hours running.

When the valves approach the maximum wear limit, the rockers can be removed and a measurement from the cylinder head face to the top of the valve stems can be taken. When a new valve is installed, the protrusion of the valve stem would be 29.75 mm (1.171 inch). Therefore, a maximum wear limit would be 30.75 mm (1.211 inch).

i07443601

i06533861

## Radiator - Clean

**Note:** Adjust the frequency of cleaning according to the effects of the operating environment. The radiator and the aftercooler are a combined unit ensure that the aftercooler is also cleaned and inspected.

Inspect the radiator and aftercooler for these items: Damaged fins, corrosion, dirt, grease, insects, leaves, oil, and other debris. Clean the radiator and aftercooler, if necessary.

### WARNING

**Personal injury can result from air pressure.**

**Personal injury can result without following proper procedure. When using pressure air, wear a protective face shield and protective clothing.**

**Maximum air pressure at the nozzle must be less than 205 kPa (30 psi) for cleaning purposes.**

Pressurized air is the preferred method for removing loose debris. Direct the air in the opposite direction to the fans air flow. Hold the nozzle approximately 6 mm (0.25 inch) away from the radiator fins. Slowly move the air nozzle in a direction that is parallel with the radiator tube assembly. This action will remove debris that is between the tubes.

Pressurized water may also be used for cleaning. The maximum water pressure for cleaning purposes must be less than 275 kPa (40 psi). Use pressurized water to soften mud. Clean the core from both sides.

Use a degreaser and steam for removal of oil and grease. Clean both sides of the core. Wash the core with detergent and hot water. Thoroughly rinse the core with clean water.

After cleaning the radiator and aftercooler, start the engine. Run the engine. This action helps remove debris and the drying of the core. Stop the engine. Use a light bulb behind the core to inspect the core for cleanliness. Repeat the cleaning, if necessary.

Inspect the fins for damage. Bent fins may be opened with a "comb". Inspect these items for good condition: Welds, mounting brackets, air lines, connections, clamps, and seals. Make repairs, if necessary.

## Severe Service Application - Check

Severe service is the application of an engine that exceeds the current published standards for that engine. Perkins maintains standards for the following engine parameters:

- Performance such as power range, speed range, and fuel consumption
- Fuel quality
- Operational Altitude
- Maintenance intervals
- Oil selection and maintenance
- Coolant type and maintenance
- Environmental qualities
- Installation
- The temperature of the fluid in the engine

Refer to the standards for the engine or consult your Perkins distributor to determine if the engine is operating within the defined parameters.

Severe service operation can accelerate component wear. Engines that operate under severe conditions may need more frequent maintenance intervals to ensure maximum reliability and retention of full service life.

Perkins engines are unable to identify all the factors which can contribute to severe service operation, due to individual applications. Consult your Perkins dealer or your Perkins distributor for the unique maintenance that is necessary for the engine.

The operating environment, incorrect operating procedures, and incorrect maintenance procedures can be factors which contribute to a severe service application.

Fuel with cleanliness levels from ISO 18 to ISO 21 will require the optional CFM (Clean Fuel Module) equipment to achieve 500hr filter change interval.

For fuel cleanliness of ISO 21 and above a customer supplied fuel pre-cleaner or scrubber will be required to condition the fuel to below the ISO 18 or ISO 21 depending upon the fuel filter option selected.

## Environmental Factors

**Ambient temperatures** – The engine may be exposed to extended operation in extremely cold environments or hot environments. Valve

components can be damaged by carbon buildup if the engine is frequently started and stopped in very cold temperatures. Extremely hot intake air reduces engine performance.

**Quality of the air** – The engine may be exposed to extended operation in an environment that is dirty or dusty, unless the equipment is cleaned regularly. Mud, dirt, and dust can encase components. Maintenance can become very difficult. The buildup can contain corrosive chemicals.

**Buildup** – Compounds, elements, corrosive chemicals, and salt can damage some components.

**Altitude** – Problems can arise when the engine is operated at altitudes that are higher than the intended settings for that application. Necessary adjustments should be made.

## Incorrect Operating Procedures

- Frequent hot shutdowns
- Operating at excessive loads
- Operating at excessive speeds
- Operating outside the intended application

## Incorrect Maintenance Procedures

- Extending the maintenance intervals
- Failure to use recommended fuel, lubricants, and coolant/antifreeze

i07395731

## Starting Motor - Inspect

Perkins recommends a scheduled inspection of the starting motor. If the starting motor fails, the engine may not start in an emergency situation.

Check the starting motor for proper operation. Check the electrical connections and clean the electrical connections. Refer to the Service Manual for more information on the checking procedure and for specifications or consult your Perkins distributors for assistance.

i06532154

## Turbocharger - Inspect

Periodic inspection and cleaning are recommended for the turbochargers. Fouling of the turbine wheels can contribute to loss of engine power and overall loss of engine efficiency.

If a turbocharger fails during engine operation, damage to the turbocharger compressor wheel and/or to the engine may occur. Damage to a turbocharger compressor wheel could allow parts from the compressor wheel to enter an engine cylinder. This debris can damage the pistons, the valves, and the cylinder head.

For information on inspection of the turbocharger, refer to "Systems Operation Testing and Adjusting" Turbocharger.

i02415322

## Walk-Around Inspection

A walk-around inspection should only take a few minutes. When the time is taken to perform these checks, costly repairs and accidents can be avoided.

For maximum engine service life, make a thorough inspection of the engine compartment before starting the engine. Look for items such as oil leaks or coolant leaks, loose bolts, worn belts, loose connections and trash buildup. Make repairs, as needed:

- The guards must be in the correct place. Repair damaged guards or replace missing guards.
- Wipe all caps and plugs before the engine is serviced in order to reduce the chance of system contamination.

---

### NOTICE

For any type of leak (coolant, lube, or fuel) clean up the fluid. If leaking is observed, find the source and correct the leak. If leaking is suspected, check the fluid levels more often than recommended until the leak is found or fixed, or until the suspicion of a leak is proved to be unwarranted.

---



---

### NOTICE

Accumulated grease and/or oil on an engine is a fire hazard. Remove the accumulated grease and oil. Refer to Operation and Maintenance Manual, "Engine - Clean" for more information.

---

- Ensure that the cooling system hoses are correctly clamped and that the cooling system hoses are tight. Check for leaks. Check the condition of all pipes.
- Inspect the water pumps for coolant leaks.

**Note:** The water pump seal is lubricated by the coolant in the cooling system. It is normal for a small amount of leakage to occur as the engine cools down and the parts contract.



Excessive coolant leakage may indicate the need to replace a water pump. Refer to Operation and Maintenance Manual, "Water Pump - Inspect" for more information. If necessary, consult your Perkins dealer or your Perkins distributor.

- Inspect the lubrication system for leaks at the front crankshaft seal, the rear crankshaft seal, the oil pan, the oil filters and the rocker cover.
- Inspect the piping for the air intake system and the elbows for cracks and for loose clamps. Ensure that hoses and tubes are not contacting other hoses, tubes, wiring harnesses, etc.
- Ensure that the areas around the rotating parts are clear.
- Inspect the alternator belt and fan drive belts for cracks, breaks or other damage.
- Inspect the wiring harness for damage.

Belts for multiple groove pulleys must be replaced as matched sets. If only one belt is replaced, the belt will carry more load than the belts that are not replaced. The older belts are stretched. The additional load on the new belt could cause the belt to break.

i04326852

## Water Pump - Inspect

A failed water pump may cause severe engine overheating problems that could result in the following conditions:

- Cracks in the cylinder head
- A piston seizure
- Other potential damage to the engine

**Note:** The water pump seal is lubricated by the coolant in the cooling system. A normal condition is that a small amount of leakage to occur as the engine cools down and parts contract.

Visually inspect the water pumps for leaks. The water pumps are not serviceable items. Replace a leaking water pump. Refer to Disassembly and Assembly for more information.

## Warranty Section

## Warranty Information

i06590874

### Emissions Warranty Information

This engine may be certified to comply with exhaust emission and gaseous emission standards that are prescribed by the law at the time of manufacture. This engine may be covered by an Emissions Warranty. Consult your authorized Perkins dealer or distributor to determine if your engine is emissions certified and if your engine is subject to an Emissions Warranty.

# Index

## A

After Stopping Engine .....	35
Aftercooler Core - Inspect .....	52
Alternator - Inspect .....	52
Alternator Pulley - Check.....	52

## B

Battery - Replace .....	52
Battery Electrolyte Level - Check .....	53
Battery or Battery Cable - Disconnect.....	53
Before Starting Engine .....	13
Belts - Inspect/Adjust/Replace .....	56
Adjust .....	56
Inspect .....	56
Replace.....	57
Belts - Inspect/Adjust/Replace (Alternator Belt) .....	57
Adjustment.....	58
Inspection .....	57
Replace the Belt .....	58
Belts - Inspect/Adjust/Replace (Fan Drive Belts for 4008-30 Only).....	54
Adjustment.....	54
Inspection .....	54
Replacement.....	55
Burn Prevention.....	9
Batteries.....	10
Coolant .....	9
Diesel Fuel .....	10
Oils.....	10
Viton Seals.....	10

## C

Cold Weather Operation .....	36
Cold Weather Starting .....	33
Configuration Parameters .....	32
System Configuration Parameters .....	32
Cooling System Coolant (ELC) - Change .....	58
Drain .....	59
Fill .....	60
Flush .....	60
Cooling System Coolant Level - Check.....	61
Crankshaft Vibration Damper - Inspect.....	61
Crushing Prevention and Cutting Prevention..	12

## D

Driven Equipment - Check .....	62
--------------------------------	----

## E

Electrical System.....	14
Grounding Practices .....	14
Emergency Stopping.....	35
Emissions Warranty Information .....	82
Engine - Clean.....	62
Engine Air Cleaner Element - Replace .....	62
Engine Air Cleaner Service Indicator - Inspect .....	63
Service Indicator Check.....	63
Service Indicator Reset .....	64
Engine Crankcase Breather - Clean .....	64
Engine Description .....	18
Aftermarket Products and Perkins Engines .....	20
Electronic Engine Features .....	19
Engine Service Life.....	20
Engine Specifications .....	18
Engine Diagnostics .....	32
Engine Electronics.....	14
Engine Mounts - Inspect.....	64
Engine Oil and Filter - Change .....	66
Drain the Engine Lubricating Oil.....	67
Fill the Oil Pan.....	67
Oil and Filter Change Intervals .....	66
Replace the Oil Filter .....	67
Engine Oil Level - Check.....	65
Engine Oil Pump - Inspect.....	65
Engine Oil Sample - Obtain.....	65
Initiating an Oil analysis Program .....	65
Obtain the Sample and the Analysis .....	66
Engine Operation .....	34
Engine Operation with Intermittent Diagnostic Codes .....	32
Engine Protective Devices - Check.....	68
Visual Inspection.....	68
Engine Starting.....	13, 33
Engine Stopping .....	13, 35
Engine Storage.....	21
Level "A " .....	21
Level "B " .....	21
Level "C " .....	21
Engine Valve Lash - Inspect/Adjust (Valves and Valve Bridges) .....	68

<b>F</b>		<b>H</b>	
Fan Drive Pulley - Check (4008-30 Engine Only) .....	68	Hoses and Clamps - Inspect/Replace .....	73
Fault Logging .....	32	Clamps and V-Band Clamp Torques .....	77
Features and Controls .....	25	Clamps and V-Band Locations .....	75
Fire Prevention and Explosion Prevention .....	10	Replace the Hoses and the Clamps .....	73
Ether .....	12	<b>I</b>	
Fire Extinguisher .....	12	Important Safety Information .....	2
Lines, Tubes, and Hoses .....	12	<b>L</b>	
Fluid Recommendations (Engine Oil Specification) .....	47	Lifting and Storage .....	21
Engine Oil .....	47	<b>M</b>	
General Lubricant Information .....	47	Maintenance Interval Schedule .....	51
Fluid Recommendations (General Coolant Information) .....	38	Daily .....	51
ELC Cooling System Maintenance .....	40	Every 1000 Service Hours .....	51
General Coolant Information .....	38	Every 1000 Service Hours or 1 Year .....	51
Fluid Recommendations (General Fuel Information) .....	42	Every 2000 Service Hours .....	51
Contamination Control Recommendations for Fuels .....	46	Every 300 Service Hours .....	51
Diesel Fuel Characteristics .....	44	Every 50 Service Hours or Weekly .....	51
Diesel Fuel Requirements .....	43	Every 500 Service Hours or 1 Year .....	51
General Information .....	42	Every 6000 Service Hours or 3 Years .....	51
Foreword .....	4	Every 7500 Service Hours .....	51
California Proposition 65 Warning .....	4	Every Year .....	51
Literature Information .....	4	Initial 100 Service Hours .....	51
Maintenance .....	4	Initial 500 Service Hours .....	51
Maintenance Intervals .....	5	When Required .....	51
Operation .....	4	Maintenance Recommendations .....	50
Overhaul .....	5	Maintenance Section .....	38
Safety .....	4	Model View Illustrations .....	15
Fuel and the Effect from Cold Weather .....	36	Engine Views .....	16
Fuel Conservation Practices .....	34	Radiator View .....	18
Fuel Injector - Inspect/Adjust .....	69	Model Views .....	15
Fuel Injector - Replace .....	69	Monitoring System .....	25
Fuel Related Components in Cold Weather ...	36	Action Alert .....	25
Fuel Heaters .....	36	Critical Protection Override .....	25
Fuel Tanks .....	36	Diagnostic .....	26
Fuel System - Prime .....	69	Shutdown .....	25
Fuel System Primary Filter - Replace .....	70	Shutdown Reset .....	26
Fuel System Primary Filter/Water Separator - Drain .....	71	Standard Warning Outputs .....	26
Fuel System Secondary Filter - Replace .....	71	Warning Alarm .....	25
Fuel Tank Water and Sediment - Drain .....	72	Mounting and Dismounting .....	13
Drain the Water and the Sediment .....	72	<b>O</b>	
Fuel Storage Tanks .....	73	Operation Section .....	21
Fuel Tank .....	72	Overhaul (Major) .....	77
Fuel Transfer Pump (Lift Pump) - Inspect .....	73	Major Overhaul Information .....	78
		Scheduling a Major Overhaul .....	77

Overhaul (Top End) .....	78
Scheduling a Top End Overhaul .....	78
Top End Overhaul Information .....	78

**P**

Product Information Section .....	15
Product Lifting .....	21
Engine Only .....	21
Radiator Only .....	24

**R**

Radiator - Clean .....	79
Refill Capacities .....	38
<b>Cooling System</b> .....	38
<b>Fuel System</b> .....	38
<b>Lubrication System</b> .....	38

**S**

Safety Messages .....	6
1 Universal Warning .....	7
2 Do Not Step .....	7
3 Hot Surface .....	8
4 Hot Fluid Under Pressure .....	8
5 Ether Warning .....	9
6 Rotating Shaft Hand Crush Hazard .....	9
Safety Section .....	6
Self-Diagnostics .....	32
Sensors and Electrical Components (Electrical Components) .....	30
Sensors and Electrical Components (Sensors Only) .....	27
Engine Sensor Views .....	28
Severe Service Application .....	50
Environmental Factors .....	50
Incorrect Maintenance Procedures .....	50
Incorrect Operating Procedures .....	50
Severe Service Application - Check .....	79
Environmental Factors .....	79
Incorrect Maintenance Procedures .....	80
Incorrect Operating Procedures .....	80
Starting Motor - Inspect .....	80
Stopping the Engine .....	35

**T**

Table of Contents .....	3
Turbocharger - Inspect .....	80

**W**

Walk-Around Inspection .....	80
Warranty Information .....	82
Warranty Section .....	82
Water Pump - Inspect .....	81

# Product and Dealer Information

Note: For product identification plate locations, see the section "Product Identification Information" in the Operation and Maintenance Manual.

Delivery Date: \_\_\_\_\_

## Product Information

Model: \_\_\_\_\_

Product Identification Number: \_\_\_\_\_

Engine Serial Number: \_\_\_\_\_

Transmission Serial Number: \_\_\_\_\_

Generator Serial Number: \_\_\_\_\_

Attachment Serial Numbers: \_\_\_\_\_

Attachment Information: \_\_\_\_\_

Customer Equipment Number: \_\_\_\_\_

Dealer Equipment Number: \_\_\_\_\_

## Dealer Information

Name: \_\_\_\_\_ Branch: \_\_\_\_\_

Address: \_\_\_\_\_

\_\_\_\_\_

\_\_\_\_\_

Dealer Contact

Phone Number

Hours

Sales: \_\_\_\_\_

Parts: \_\_\_\_\_

Service: \_\_\_\_\_



