



## Installation and Pilot's Guide



© 2018 uAvionix Corporation. All rights reserved.

uAvionix Corporation  
300 Pine Needle Lane  
Bigfork, MT 59911

<http://www.uavionix.com>

[support@uavionix.com](mailto:support@uavionix.com)

Except as expressly provided herein, no part of this guide may be reproduced, transmitted, disseminated, downloaded or stored in any storage medium, for any purpose without the express written permission of uAvionix. uAvionix grants permissions to download a single copy of this guide onto an electronic storage medium to be viewed for personal use, provided that the complete text of this copyright notice is retained. Unauthorized commercial distribution of this manual or any revision hereto is strictly prohibited.

uAvionix® is a registered trademark of uAvionix Corporation, and may not be used without express permission of uAvionix.

# 1 Revision History

Revision	Date	Comments
A	2/27/2017	Initial release
B	3/6/2017	
C	3/28/2017	GTX Protocol Support
D	5/25/17	Export Control
E	5/31/2017	Traffic on COM1
F	8/14/2017	Aligns with Echo Installer App Updates
G	8/17/2017	Added Garmin GTN and GRT SafeFly app notes
H	11/24/2017	Added AFS traffic app note
I	12/21/2017	Updated Apollo SL70 app note with TX setting
J	2/19/2018	echoUATmux harness/Navworx Retrofit
K	4/2/2018	Update transponder language
L	10/10/2018	Update Legacy Transponder wiring diagram C-1

## **2 Warnings / Disclaimers**

All device operational procedures must be learned on the ground.

Received weather and traffic information is to be used as an aid to situational awareness, and is merely supplemental and advisory in nature.

uAvionix is not liable for damages arising from the use or misuse of this product.

This equipment is classified by the United States Department of Commerce's Bureau of Industry and Security (BIS) as Export Control Classification Number (ECCN) 7A994.

These items are controlled by the U.S. Government and authorized for export only to the country of ultimate destination for use by the ultimate consignee or end-user(s) herein identified. They may not be resold, transferred, or otherwise disposed of, to any other country or to any person other than the authorized ultimate consignee or end-user(s), either in their original form or after being incorporated into other items, without first obtaining approval from the U.S. government or as otherwise authorized by U.S. law and regulations.

### 3 Limited Warranty

uAvionix products are warranted to be free from defects in material and workmanship for one year from the of installation in the aircraft. For the duration of the warranty period, uAvionix, at its sole option, will repair or replace any product which fails in normal use. Such repairs or replacement will be made at no charge to the customer for parts or labor, provided that the customer shall be responsible for any transportation cost.

Restrictions: This warranty does not apply to cosmetic damage, consumable parts, damage caused by accident, abuse, misuse, water, fire or flood, damage caused by unauthorized servicing, or product that has been modified or altered.

Disclaimer of Warranty: IN NO EVENT, SHALL UAVIONIX BE LIABLE FOR ANY INCIDENTAL, SPECIAL, INDIRECT OR CONSEQUENTIAL DAMAGES, WHETHER RESULTING FROM THE USE, MISUSE OR INABILITY TO USE THE PRODUCT OR FROM DEFECTS IN THE PRODUCT. SOME STATES DO NOT ALLOW THE EXCLUSION OF INCIDENTAL OR CONSEQUENTIAL DAMAGES, SO THE ABOVE LIMITATIONS MAY NOT APPLY TO YOU.

Warranty Service: Warranty repair service shall be provided directly by uAvionix. Proof of purchase for the product from uAvionix or authorized reseller is required to obtain and better expedite warrant service.

Please email or call uAvionix with a description of the problem you are experiencing. Also, please provide the model, serial number (if applicable), shipping address and a daytime contact number.

You will be promptly contacted with further troubleshooting steps or return instructions. It is recommended to use a shipping method with tracking and insurance.

## 4 Contents

1	Revision History .....	3
2	Warnings / Disclaimers.....	4
3	Limited Warranty .....	5
5	Introduction .....	8
5.1	Features .....	8
5.2	Regulatory Compliance .....	9
5.2.1	FCC Grant of Equipment Authorization .....	9
5.3	Interfaces .....	10
5.4	Software and Airborne Electronic Hardware Configuration.....	10
5.5	Supplied Accessories .....	10
6	Technical Specifications .....	12
6.1	Markings.....	12
7	Equipment Limitations .....	13
7.1	Installation .....	13
7.1.1	Modifications and Use Outside of Intended Scope .....	13
7.1.2	Deviations .....	13
7.1.3	Configurable Options .....	13
7.1.4	Approvals.....	13
7.2	Unpacking and Inspecting.....	13
7.3	Mounting .....	13
7.4	Connections .....	14
7.5	Connector Pin Assignments.....	15
7.6	Cooling Requirements .....	15
7.7	Wiring Considerations.....	16
7.8	Antenna Installation .....	17
7.8.1	Antenna .....	17
7.8.2	Antenna Cable .....	18

8	Installation Setup.....	20
8.1.1	Connecting to the echoUAT via Wi-Fi.....	20
8.2	Configuration .....	21
8.2.1	Control .....	21
8.2.2	Aircraft Address Programming .....	22
8.2.3	Call Sign .....	22
8.2.4	Flight-plan ID .....	22
8.2.5	CSID Logic.....	22
	Note: CSID should always be "Enabled", unless there is a special circumstance requiring it be set to "Disabled". .....	23
8.2.6	Anonymous Mode .....	23
8.2.7	Emitter Category .....	23
8.2.8	VFR Squawk code .....	23
8.2.9	ADSB-In Capability .....	23
8.2.10	VSO (knots) .....	24
8.2.11	Aircraft Length and Width in Meters .....	24
8.2.12	GPS Antenna Offset.....	25
8.3	Installation .....	25
8.3.1	Serial Port Setup.....	26
9	Normal Operation .....	27
9.1	Electronic Flight Bag Application.....	27
10	Environmental Qualification Forms .....	29

## 5 Introduction

The echoUAT is a remotely mounted ADS-B transceiver that incorporates a dual-link (1090 MHz and 978 MHz) receiver and 978 MHz UAT Class B1S transmitter. An internal power transcoder detects altitude, ident and squawk codes from older-style Mode C or Mode S transponders by decoding the replies via the aircraft electrical system. No additional wiring to the transponder is required. The echoUAT has integrated Wi-Fi support to interface with most EFB applications, and integrates with a wide variety of existing EFIS systems. For use with either the SKYFYX GPS source or with an existing rule compliant GPS source.

It is designed to meet the performance requirements of TSO-C154c, and is compliant with FAR 91.225 and FAR 91.227 for operation in the National Airspace System.



**The system is for use in Experimental and LSA aircraft only.**

### 5.1 Features

The echoUAT performs the following functions:

- UAT transmission (978 MHz)
  - Transmits ADS-B Out data on the 978 MHz frequency.
  - Optional Anonymous Mode with 1200 VFR squawk code.
- UAT reception (978 MHz)
  - Receives ADS-B In data from other UAT transmitters, including aircraft, vehicles, and ground stations. This includes ADS-B, ADS-R, TIS-B and FIS-B data.
- 1090ES reception (1090 MHz)
  - Receives ADS-B In data from aircraft equipped with 1090 MHz Extended Squitter transmitters.
- Transponder interface

- The power transcoder allows monitoring of existing Mode C, or Mode S transponders via the aircraft electrical system.
- Direct serial connection for direct-wire transponders or EFIS integration.
- Traffic correlation
  - Traffic information from both UAT and 1090ES are correlated to provide a coherent view of nearby aircraft.
- GDL 90 output
  - Traffic and FIS-B data is translated to standard GDL 90 format.
- Wi-Fi EFB connection
  - The GDL 90 data is transmitted over the built-in Wi-Fi interface for reception by standards compliant Electronic Flight Bag (EFB) applications.

## 5.2 Regulatory Compliance

The echoUAT meets the Minimum Operational Performance Standards of DO-282B Class B1S, and meets the performance requirements of TSO-C154c. It complies with the ADS-B Final Rule Technical Amendment, dated 2/9/2015, affecting 14 CFR 91.225 (b)(1)(ii) which permits ADS-B Out in the National Airspace System for devices meeting the performance requirements of TSO-C154c. Accordingly, when installed in accordance with the installation instructions of this guide, the device complies with the aircraft requirements of 14 CFR 91.227.

(Per the February 9, 2015 rule change to 14 CFR 91.225 (b)(1)(ii))  
 (A letter of authorization from the aircraft manufacturer is needed for installation in LSA aircraft)

### 5.2.1 FCC Grant of Equipment Authorization

This equipment has been issued an FCC Grant of Equipment Authorization.

The equipment contains FCC ID 2AFFTUAT016 and is marked on the equipment nameplate.

The equipment also contains FCC ID 2ADUIESP-12 and is marked on the equipment nameplate.

### 5.3 Interfaces

The echoUAT has a single SMA antenna connection, a 6-pin Host interface and an integrated Wi-Fi adapter.

Interface	Specification	Devices
COM1	Setup Mode, Altitude, Squawk, Ident GPS Position	Dynon, MGL, GRT, AFS, Garmin, Sandia, Apollo
COM2 RX	GPS Position	SKYFYX, Garmin WAAS, Accord Micro-i
COM2 TX	ADS-B Traffic ADS-B Uplink Services	MGL, GRT, AFS
Wi-Fi	Setup ADS-B Traffic ADS-B Uplink Services	iPad, Android

### 5.4 Software and Airborne Electronic Hardware Configuration.

Part	Part Number	Revision
Software	UAV-1001007-001	A
Airborne Electronic Hardware	UAV-1001008-001	A

### 5.5 Supplied Accessories

Part	Part Number	Revision
echoUAT	UAV-1000957-001	A
SMA-BNC Adapter	UAV-1001011-001	
Wiring Harness	UAV-1001010-001	
Monopole Antenna	UAV-1001009-001	A
echoUAT User Manual	UAV-1001006-001	H



## 6 Technical Specifications

Specification	Characteristics
Compliance	Meets the performance requirements of TSO-C154c
FCC ID	2AFFTUAT016
FAA Transmit License	Manned and un-manned aircraft.
Software	RTCA DO-178B Level C
Hardware	RTCA DO-254 Level C
Power Requirements	11 – 33VDC. Typical 2W On/Alt, 0.1W Standby DO-160G Category Z
Altitude	18,000ft
Operating Temperature	-45°C to +70°C
Humidity	Tested to Category DO-160G Category B2
Transmit Frequency	978MHz ±1MHz
Transmit Power	20W nominal
Transmitter Modulation	1M29G1D
Receiver Frequency	978MHz 1090MHz
Receiver Sensitivity	978MHz: -90 to -3dBm 1090MHz: -79 to 0dBm
Weight	60grams
Height	19mm
Length	55mm
Width	65mm

### 6.1 Markings



## **7 Equipment Limitations**

### **7.1 Installation**

#### **7.1.1 Modifications and Use Outside of Intended Scope**

This device has been designed and tested to conform to all applicable standards in the original form and when configured with the components shipped with the device. It is not permissible to modify the device, use the device for any use outside of the intended scope.

#### **7.1.2 Deviations**

There are no deviations from the MPS of TSO-C154c Class B1S Device.

#### **7.1.3 Configurable Options**

Accessing or altering configurable options not intended to be operated may cause pilot distraction.

#### **7.1.4 Approvals**

Approvals do not cover adaptations to the aircraft necessary to accommodate ancillary equipment such as power provisions, mounting devices or external antennas; such items must still be approved under existing minor modification/change processes applicable to the aircraft.

### **7.2 Unpacking and Inspecting**

Carefully unpack the device and make a visual inspection of the unit for evidence of any damage incurred during shipment. If the unit is damaged, notify the shipping company to file a claim for the damage. To justify your claim, save the original shipping container and all packing materials.

### **7.3 Mounting**

The echoUAT is designed to be mounted in any convenient location in the cockpit, the cabin, or an avionics bay.

The following installation procedure should be followed, remembering to allow adequate space for installation of cables and connectors.

- Select a position in the aircraft that is not too close to any high external heat source. The echoUAT is not a significant heat source

itself and does not need to be kept away from other devices for this reason.

- Avoid sharp bends and placing the cables too near to the aircraft control cables.
- Secure the transceiver to the aircraft via the four (4) mounting holes. It should be mounted on a flat surface.
- If possible, care should be taken to mount EchoUAT in a location with the top case being visible for initial or periodic inspection of the LED status lights.

Note: Installation of the echoUAT must be in accordance with AC43.13-2B, Chapter 1

## 7.4 Connections

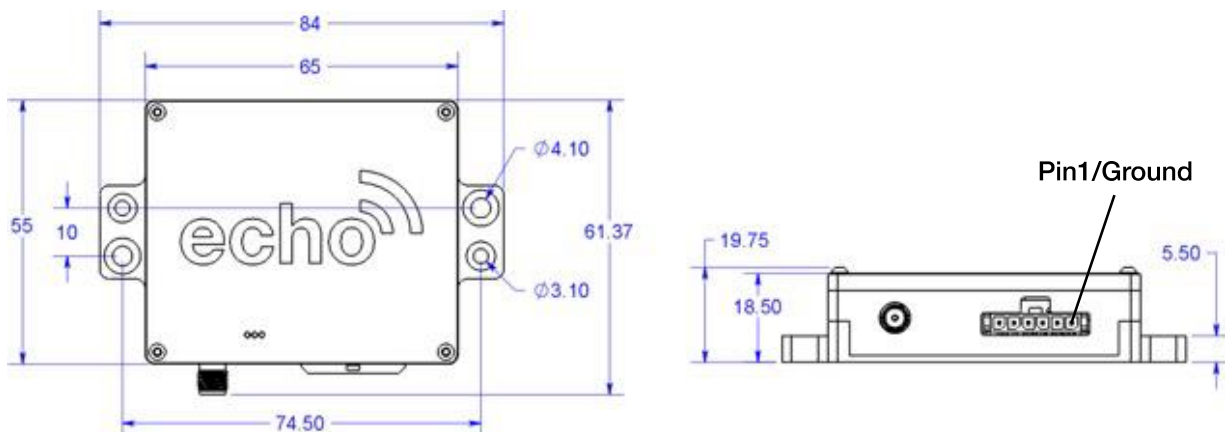

**!** Whenever power is supplied to the transceiver, a 50ohm load must be provided to the SMA connection. You can use the supplied antenna or a commercially available 50ohm load.

## 7.5 Connector Pin Assignments

Pin	Type	Physical	Default Config	Default Protocol
1	Ground	-	-	-
2	Aircraft Power	11-33V	-	-
3	COM1 TX	RS232 Out RS485 A(-)	RS232 38400bps 81O	TMAP
4	COM1 RX	RS-232 In RS485 B(+)	RS232 38400bps 81O	TMAP
5	COM2 TX	RS-232 Out	115200bps 81N	GDL 90
6	COM2 RX	RS-232 In	115200bps 81N	NMEA
Mating Connector: Molex 0436450600, Pins: 0462350001				

Note: Use a 1A circuit breaker between the power source and echoUAT. Optionally, a 3a gang circuit breaker can be used when combining echoUAT and SkyFYX on the same circuit.

LED	SOLID	FLASHING
RED	FAULT	Transmit
GREEN	Powered	Receive

## 7.6 Cooling Requirements

echoUAT is designed to meet all applicable TSO requirements without forced-air cooling.

Attention should, however, be given to the incorporation of cooling provisions to limit the maximum operating temperature if the echoUAT is installed in close proximity to other avionics. The reliability of equipment operating in close proximity in an avionics bay can be degraded if adequate cooling is not provided.

## 7.7 Wiring Considerations

The echoUAT was designed and tested using unshielded, untwisted wiring. There may, however, be technical benefits of improved electromagnetic emissions and susceptibility to and from the transponder system. The use of twisted wire can reduce interference and break-through on adjacent audio wiring if it is not possible to route them separately.

The distance between the echoUAT and the power source is limited by the impedance of the wire between them. The echoUAT is powered directly from aircraft power, and, therefore, the acceptable voltage drop in the power line is what limits the distance.

A 1A circuit breaker should be used between the echoUAT and the power source. A 3A gang circuit breaker can be used when echoUAT and SkyFYX are combined on the same circuit.

The echoUAT requires an impedance of less than 0.5ohm in the power line for satisfactory operation. The following table provides guidance for a typical aircraft hook-up wire. Note that different brands may vary – please check your supplier for more details.

Gauge	ohm/km	Length for 0.5ohm
20 AWG	35	14.2m
22 AWG	64	7.8m
24 AWG	99	5.0m

An alternative to a harness built from individual wires, particularly for a long cable run, is to use a multi-core cable. Aviation grade cables with 6 or more cores are often more expensive than individual wires, and, therefore, are not generally a good choice. For aircraft where those situations do not apply, an attractive alternative solution may be to use 3 or 4 pair data cable.

Please note that not all data cable is suitable for this application. Cables with solid cores should not be used. Cables should be selected based on the wear characteristics of their insulation material, including temperature rating, resistance to solvents and oils, and flammability. Most inexpensive commercial data cables have poor flammability properties.

## 7.8 Antenna Installation

### 7.8.1 Antenna

The antenna should be installed according to the manufacturer's instructions.

The following considerations should be taken into account when determining an acceptable location for the antenna.

- The antenna should be well removed from any projections, the engine(s) and propeller(s). It should also be well removed from landing gear doors, access doors or other openings which will break the ground plane for the antenna.
- The antenna should be mounted on the bottom surface of the aircraft and in a vertical position when the aircraft is in level flight.
- Avoid mounting the antenna within 1 meter of an existing transponder, ADF sense antenna or any COMM antenna and 2 meters from the DME antenna.
- Where practical, plan the antenna location to keep the cable lengths as short as possible and avoid sharp bends in the cable to minimize the VSWR or signal loss.

Electrical connection to the antenna should be protected to avoid loss of efficiency due to exposure to liquids and moisture. All antenna feeders shall be installed in such a way to minimize RF energy radiated inside the aircraft.

When a conventional aircraft monopole antenna is used, it relies on a ground plane for correct behavior. For ideal performance, the ground plane should be large relative to the wavelength of the transmission, which is 275mm. In a metal, skinned aircraft this is usually easily accomplished, but is more difficult in a composite or fabric skinned aircraft. In these cases, a metallic ground plane should be fabricated and fitted under the antenna.

The ground plane should be as large as you can sensibly make it. Because it is a function of the wavelength of the transmission, the smallest practical ground plane for a transponder is approx. 120mm per side. As the size increases, the performance improves, until the ground plane is approx.

700mm on each side. Anything much larger than that size is unlikely to result in significant further improvement.

The thickness of the material used to construct the ground plane is not critical, providing it is sufficiently conductive. A variety of proprietary mesh and grid solutions are available. Heavyweight aluminum foil meets the technical requirement, but obviously needs to be properly supported.

### **7.8.2 Antenna Cable**

The echoUAT is designed to meet Class B1S. Excessive loss in the cable and connectors will degrade both transmitter output power and receiver sensitivity.

An acceptable cable:

- has less than 1.5dB loss for the run length needed,
- has a characteristic impedance of 50ohms,
- has double braid screens or has foil and braid screen.

Once the cable run length is known, a cable type with low enough loss per meter that meets the above requirements can be chosen. Longer runs require lower loss cable.

The following table is a guide to the maximum usable lengths of some common cable types. Actual cable loss varies between manufacturers. There are many variants, and the table is based on typical data. Use it as a guide only and refer to the manufacturer's data sheet for your specific chosen cable for accurate values.

Length (meters)	Insertion Loss (dB/m)	MIL-C 17	Specialists	SSB Electronic
2.54	0.59	M17/128		
2.54	0.59	RG400		
3.16	0.47		3C142B	
3.81	0.39	RG304		
4.5	0.33			Aircell 5
5.25	0.29	RG393	311601	
6.42	0.23		311501	
6.81	0.18			Aircell 7
8.22	0.18		311201	
12.59	0.12		3108801	

When routing the cable:

- Route the cable away from any significant heat sources
- Route the cable wiring away from potential interference sources such as ignition wiring, 400Hz generators, fluorescent lighting and electric motors
- Allow a minimum separation of 300mm from an ADF antenna cable
- Keep the cable run as short as possible
- Avoid routing the cable around tight bends
- Avoid kinking the cable, even temporarily, during installation
- Secure the cable so that it cannot interfere with other systems

## 8 Installation Setup

Download the “uAvionix Echo Installer” app from the IOS App store or Google Play. Note: Do not use the “uAvionix Ping Installer” app by mistake.



### 8.1.1 Connecting to the echoUAT via Wi-Fi

To connect to the echoUAT, join a device to the wireless network named “Echo-XXXX” using the procedure for your device. iOS is shown below:

1. Go to **Settings > Wi-Fi**, and make sure that Wi-Fi is turned on.
2. Tap the SSID **Ping-XXXX** where XXXX is a random string. i.e. Ping-6A8E.
3. No WPA Password is required.\*

\*Some early software builds require a WPA password... Enter **uavionix** as the WPA password for the secure Wi-Fi network, then tap join. Note: **The No Internet Connection** message is normal when iOS is connected to echoUAT.

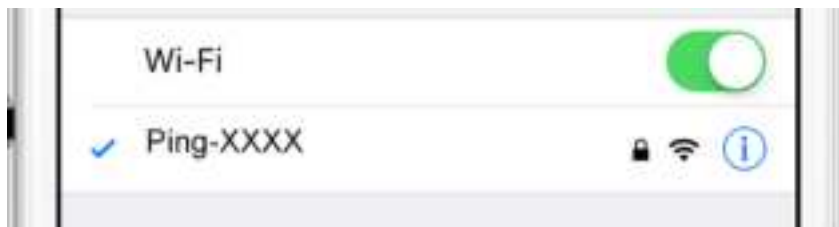

4. Launch the Echo App on your tablet or smartphone.



Make sure “EchoUAT is the Selected Device Type.

## 8.2 Configuration

The configuration section will set the following parameters:

- Control
- ICAO Number
- Call Sign
- Flight Plan ID
- CSID Logic
- Anonymous Mode
- Emitter Category
- VFR Code
- ADS-B In Capability
- Vso
- Aircraft Length and Width
- GPS Antenna Offset



### 8.2.1 Control

Select the desired control type. This setting configures the echoUAT for Transmit, Receive or Standby.

- UAT TX Enabled: Enables both transmit and receive functions. This is the recommended mode for 2020 compliance..

- Receive Only: Disables transmission but continues to receive and provide ADS-B data to a GDL90 compatible display or application.
- Standby: Disables both the transmit and receive functions. GDL90 position data (GPS) is still available from the device.

### **8.2.2 Aircraft Address Programming**

The ICAO address is a 24-bit number issued to the aircraft by the registration authority of the aircraft. These addresses are usually written as a 6-digit hexadecimal number, although you may also encounter one written as an 8-digit octal number. The echoUAT understands the hexadecimal format, so you must first convert an octal number to hexadecimal before entering.

Tip: By using the N-Number Look Up function on <https://www.faa.gov>, locate and use the “Mode S Code (base 16 / hex)” value.

### **8.2.3 Call Sign**

The CALL SIGN can be up to an 8 digit code that corresponds to the tail number of the aircraft. (0-9, A-F).

Note: This is typically your aircraft N-number, unless otherwise advised by the FAA or ATC.

### **8.2.4 Flight-plan ID**

Flight Plan ID, if provided, is used in accordance with product specific transmission requirements. CSID Logic is applied to determine if the Flight Plan ID is transmitted.

Flight Plan IDs are intended to contain Mode 3/A (12-bit) or expanded (18-bit) codes, and shall only contain between 4 and 6 characters, consisting of ASCII encoded values for digits 0-7.

Tip: Generally, this field will be left blank, unless otherwise advised by the controlling authority.

### **8.2.5 CSID Logic**

Specifies Call Sign Identification (CSID) transmission behavior. Always set CSID Logic to “Enabled” for 91.227 Compliance. A setting of “Disabled” will result in a failure to generate an ADS-B Performance report.

## **Description**

UAV-1001006-001  
ECCN 7A994

Disabled, CSID always set to 1 (Callsign)
Enabled, CSID alternates between 1 (Callsign) and 0 (Flight Plan ID)

Note: CSID should always be "Enabled", unless there is a special circumstance requiring it be set to "Disabled".

### 8.2.6 Anonymous Mode

When checked, this enables the EchoUAT to transmit a self-assigned ICAO and sets the Call Sign to a random string such as "PINGFDF8" when the squawk code matches the defined VFR squawk code. Note that anonymous mode is only active if a flight plan has not been filed (per AC 20-165).

Tip: Anonymous Mode must be "DISABLED" for the FAA Performance test flight in order for the FAA to register the flight to the aircraft's Call Sign.

### 8.2.7 Emitter Category

To assist ATC tracking of aircraft, an aircraft category can be transmitted. Select the aircraft category that most closely matches the aircraft.

Emitter Category	
Light Airplane	Rotorcraft
Small Airplane	Glider / Sailplane
Large Airplane	Lighter Than Air
Large Airplane with High Vortex	Parachute
Heavy Airplane	Ultralight
Highly Maneuverable Airplane	UAV
	Space Craft

Tip: Fixed wing with a maximum takeoff weight less than 15,000 lbs are *Light Airplanes*.

### 8.2.8 VFR Squawk code

This sets the default VFR squawk code. E.g. 1200 for the USA.

### 8.2.9 ADSB-In Capability

Sets the ADS-B in equipment capability reporting. EchoUAT is capable of receiving on frequencies. The recommended setting is "Both UAT and 1090".

ADS-B In capability
None
UAT
1090
Both UAT and 1090

### 8.2.10 VSO (knots)

This parameter allows the echoUAT to automatically switch between airborne and ground modes. Enter the VSO value for your aircraft. Setting VSO to 0 passes control of the Air/Ground state to the EFIS.

Airspeed (in kts) that the aircraft typically flies after take-off.
0 – 999 knots

Tip: If in doubt, you can set this to your maximum taxi speed. EchoUAT uses ground speed and does not account for headwind or tailwinds, that might affect the Air/Ground state.

### 8.2.11 Aircraft Length and Width in Meters

When on the ground, ADS-B transmits encoded aircraft size information which is used by ATC to identify taxiing routes and potential conflicts. Enter the length and width (wingspan) fields and the appropriate size codes will be calculated for transmission.

Aircraft Length in Meters	Aircraft Width (wing span) in Meters
$L \leq 15$	$W \leq 72.5$
$15 < L \leq 25$	$72.5 < W \leq 80$
$25 < L \leq 35$	
$35 < L \leq 45$	
$45 < L \leq 55$	
$55 < L \leq 65$	
$65 < L \leq 75$	
$75 < L \leq 85$	
$L > 85$	

### 8.2.12 GPS Antenna Offset

The GPS antenna offset is used in conjunction with the length and width to manage taxiway conflicts. A typical GPS does not report the geographic position of the center of the aircraft, or even the tip of the nose of the aircraft; instead, it usually reports the location of the actual GPS antenna (not the GPS receiver). In normal flight operation, this distinction is of no importance at all, but if ADS-B is used to manage taxiway conflicts, a significant offset in antenna position could mean the aircraft footprint is not in the same place as the ADS-B reported position. Although the GPS Antenna Offset is primarily intended for position correction on large transport aircraft, General Aviation aircraft can also have a significant offset. For example, if the aircraft has a long tail boom and the GPS antenna is on top of the tail, the GPS position could be 4 meters or more from the nose of the aircraft.

GPS Antenna Lateral Offset from roll axis (Meters)	GPS Antenna Longitudinal Offset from aircraft nose (Meters)
0	0 to 60 Meters in 2 Meter increments
Left 2	
Left 4	
Right 2	
Right 4	
Right 6	

### 8.3 Installation

The installation section will set the following parameters:

- Setup Source
- Control Source
- GPS Source
- Traffic/Uplink Output
- COM1 Rate, Data and Phy
- COM1 Protocol
- COM2 Rate



- COM2 Protocol

### 8.3.1 Serial Port Setup

Please use this parameter to configure the echoUAT to interface with a supported EFIS system or another supported device.

Supported Parameters

Parameter	Source	Port	Baud Rate	Data	Interface	Protocol
SETUP	APP	NA	NA	NA	NA	NA
	EFIS (COM1)	COM1	PROG	PROG	PROG	PROG
CONTROL	EFIS (COM1)	COM1	PROG	PROG	PROG	PROG
	XPDR MONITOR	NA	NA	NA	NA	NA
GPS	EFIS (COM1)	COM1	NA	NA	NA	NA
	EXT GPS (COM2)	COM2	PROG	PROG	RS232	NEMA
	GARMIN	COM2	PROG	PROG	RS232	ADSB+
TRAFFIC	EFIS (COM1)	COM1	PROG	PROG	RS232	GDL90
	MFD (COM2)	COM2	PROG	PROG	RS232	GDL90

\*PROG – User Programmable. Confirm the selection matches the supported device settings. Example EFIS Baud Rate should match EchoUAT setting and EFIS settings.

Equipment Examples

Equipment	Setup Source	Control Source	Traffic Uplink	GPS Source	COM1 Rate	COM1 Data	COM1 Phy	COM1 Protocol
Dynon/Skyview	EFIS	EFIS	COM2	EFIS	38400	81O	RS232	TMAP
MGL	APP	EFIS	COM2	COM2	38400	81O	RS232	TMAP
GRT	EFIS	EFIS	COM2	EFIS	38400	81O	RS485 T	TMAP
GTX33/330	APP	Panel	COM2	COM2	9600	81N	RS232	GTX
GTX32/327	APP	Panel	COM2	COM2	9600	81N	RS232	GTX
SL70	APP	Panel	COM2	COM2	9600	81N	RS232	GDL
STX165	APP	Panel	COM2	COM2	9600	81N	RS232	GDL
TC20	APP	Panel	COM2	COM2	38400	81O	RS485 T	TMAP
KT76A	APP	X MON	COM2	COM2	NA	NA	NA	NA
TC20 + TT2x	APP	Panel	COM2	COM2	38400	81O	RS485	TMAP

GPS Source = COM2, If you are using a Garmin GPS with ADS-B+ with GRT, Traffic will be set to EFIS Com1.

Equipment Examples Cont.

Equipment	COM2 Rate	COM2 Protocol
-----------	-----------	---------------

uAvionix SkyFYX	115200	NMEA
Accord Micro-i	115200	NMEA
Garmin GPS-20A	9600	ADSB+
Garmin GNS 4xxW	9600	ADSB+
Garmin GNS 5xxW	9600	ADSB+

## Commit and Confirm Configuration

1. After entering the correct information for all fields press Update. You should receive a message confirming the configuration. Tap OK.

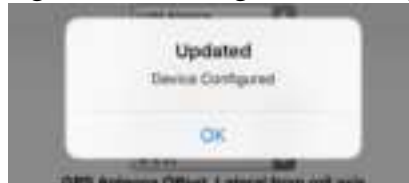

2. Tap “Monitor” just below the Echo logo. Confirm the ICAO, Callsign and Emitter shown are the correct values for your aircraft.
3. Programming of the echoUAT is now complete.

## 9 Normal Operation

### 9.1 Electronic Flight Bag Application

Launch your GDL 90 compatible Electronic Flight Bag (EFB) application.

Configure your EFB as necessary to access the uAvionix ADS-B device. In most applications, it will be automatically detected. If you do not see a device connection for the echo, ping, or uAvionix, please contact your EFB provider for additional support. ADS-B traffic and flight information should begin streaming to the application when in range. Depending on the proximity to the nearest ADS-B ground station, FIS-B data (METARs, TAFs, TFRs, etc) may not be available while on the ground.

Typical iOS application displaying ADS-B traffic from echoUAT is shown below.

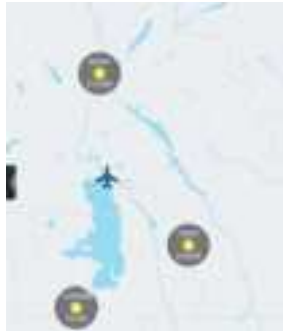

Altitude must be pre-flight cross-checked by comparing the aircraft's altimeter with the GPS altitude displayed on the EFB application.

For additional questions or support please visit <http://uavionix.com/support>

# 10 Environmental Qualification Forms

Nomenclature	echoUAT ADS-B Transmitter	
Part No: UAV-1000957-001		
Manufacturer	uAvionix Inc	
Address	380 Portage Ave, Palo Alto, CA 94306	
Conditions	DO-160G Section	Description of Conducted Tests
Temperature and Altitude	4.0	Equipment tested to Category B2
Low temperature ground survival	4.5.1	-55°C
Low Temperature Short-Time Operating	4.5.1	-45°C
Low Temperature Operating	4.5.2	-45°C
High Temperature Operating	4.5.4	+70°C
High Temperature Short-Time Operating	4.5.3	+70°C
High Temperature Ground Survival	4.5.3	+85°C
Loss of Cooling	4.5.5	Cooling air not required (+70°C operating without cooling)
Altitude	4.6.1	35,000feet
Decompression	4.6.2	Equipment identified as Category B2 – no test
Overpressure	4.6.3	Equipment identified as Category B2 – no test
Temperature Variation	5.0	Equipment tested to Category B2
Humidity	6.0	Equipment tested to Category B2
Operation Shocks	7.2	Equipment tested to Category B
Crash Safety	7.3	Equipment tested to Category B type 5
Vibration	8.0	Aircraft zone 2: type 3, 4, 5 to Category S level M, type 1 (Helicopters) to Category U level G
Explosion	9.0	Equipment identified as Category X – no test
Waterproofness	10.0	Equipment identified as Category X – no test
Fluids Susceptibility	11.0	Equipment identified as Category X – no test
Sand and Dust	12.0	Equipment identified as Category X – no test
Fungus	13.0	Equipment identified as Category X – no test
Salt Spray	14.0	Equipment identified as Category X – no test
Magnetic Field	15.0	Equipment identified as Category Z
Power Input	16.0	Equipment identified as Category ZX
Voltage Spike	17.0	Equipment identified as Category B
AF Conducted Susceptibility	18.0	Equipment identified as Category B
Induced Signal Susceptibility	19.0	Equipment identified as Category AC
RF Susceptibility	20.0	Equipment identified as Category TT
RF Emissions	21.0	Equipment identified as Category B
Lightening Induced Transient Susceptibility	22.0	Equipment identified as Category XXXX – no test
Lightening Direct Effects	23.0	Equipment identified as Category X – no test
Icing	24.0	Equipment identified as Category X – no test
Electrostatic Discharge	25.0	Equipment identified as Category X – no test
Fire, Flammability	26.0	Equipment identified as Category C

# Appendix A – Interconnect Diagrams

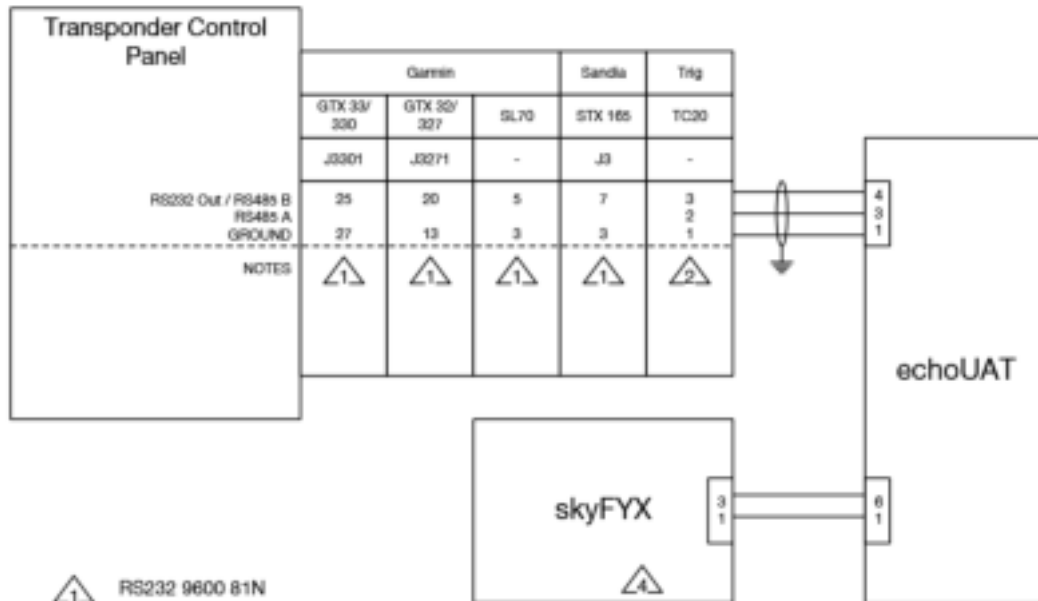

- △1 RS232 9600 81N
- △2 RS485 TERMINATED 38400 81O
- △3 RS485 UN-TERMINATED 38400 81O
- △4 115200 NMEA
- △5 9600 ADSB+

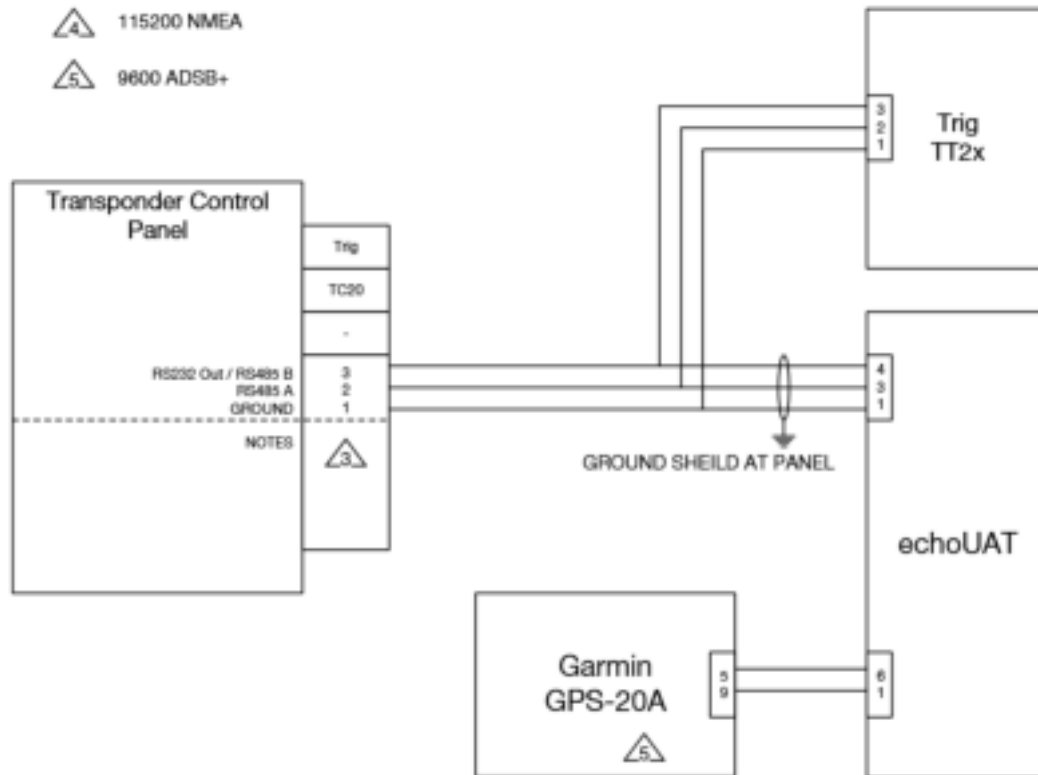

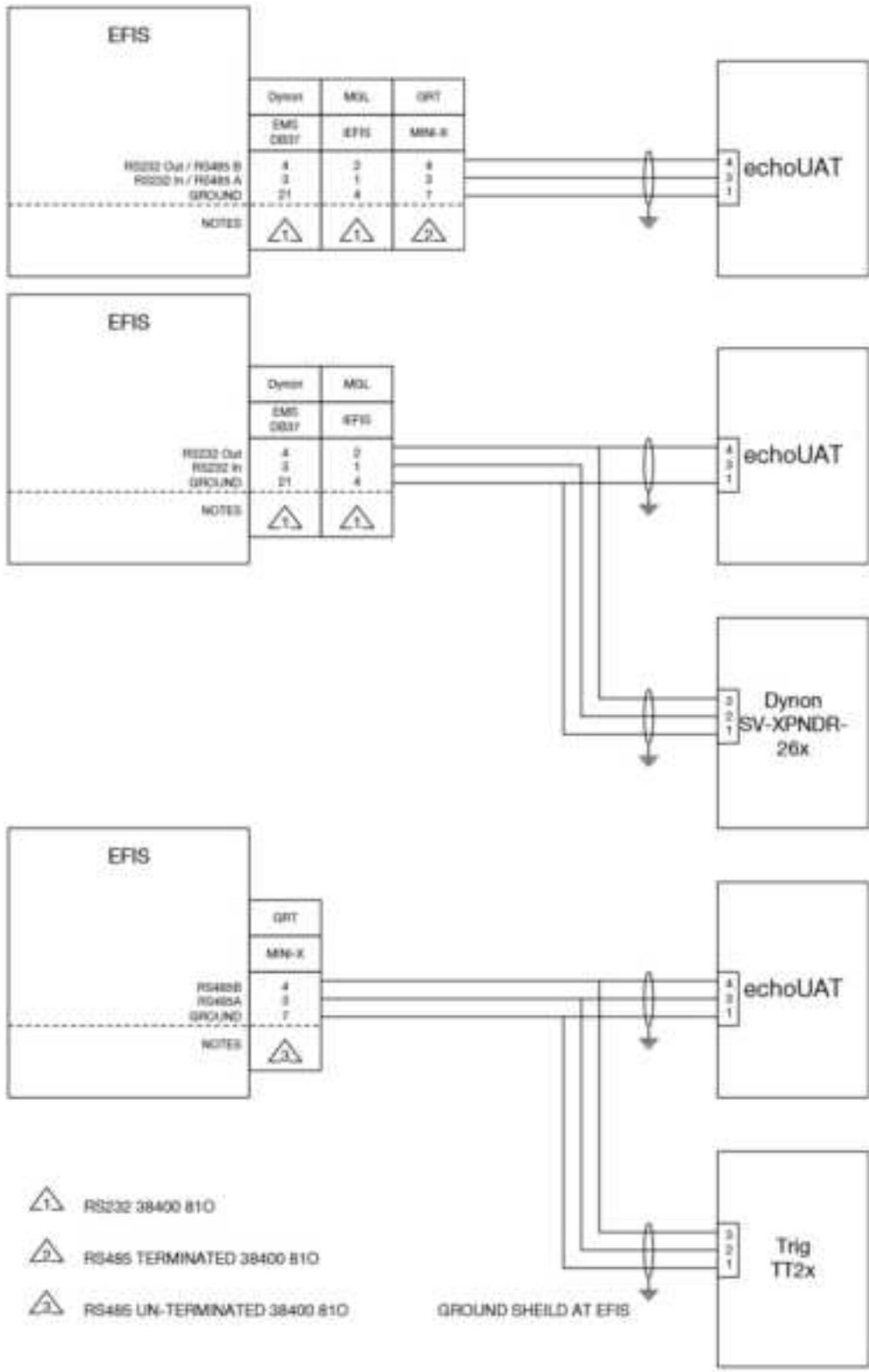

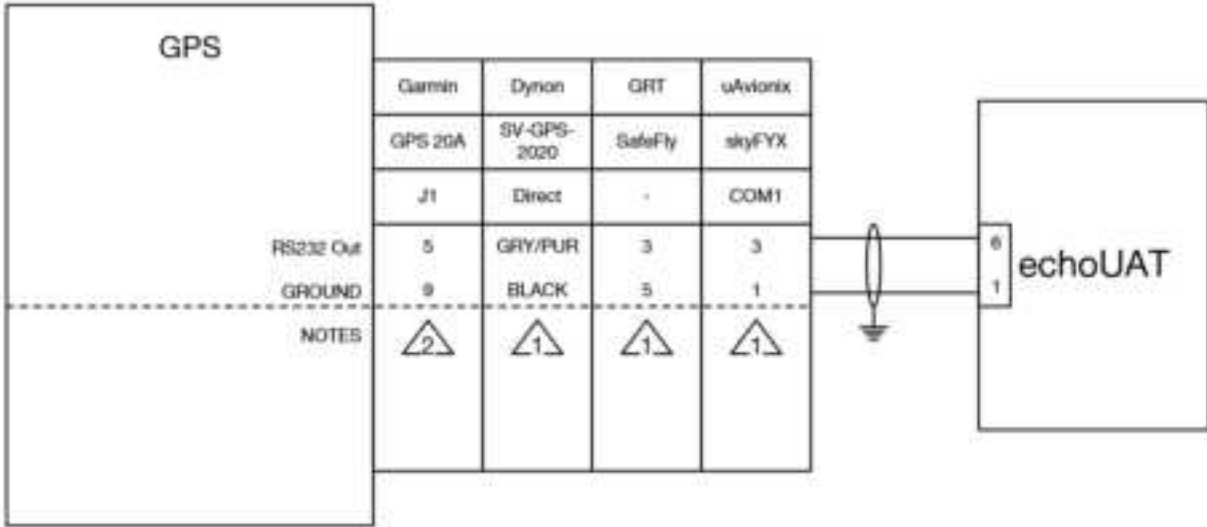

- △<sub>1</sub> NMEA 115200bps
- △<sub>2</sub> Garmin ADS-B+ 9600bps

## Appendix B - Acronyms

ADF	Automatic Direction Finder
ADS-B	Automatic Dependent Surveillance Broadcast
ADS-R	Automatic Dependent Surveillance Rebroadcast
ATC	Air Traffic Control
DME	Distance Measuring Equipment
EFB	Electronic Flight Book
EFIS	Electronic Flight Information System
FCC	Federal Communications Commission
FAA	Federal Aviation Administration
FIS-B	Flight Information Services Broadcast
GPS	Global Positioning System
ICAO	International Civil Aviation Organization
LSA	Light Sport Aircraft
RTCA	Radio Technical Commission for Aeronautics
TIS-B	Traffic Information Services Broadcast
TSO	Technical Standard Order
UAT	Universal Access Transceiver
VSO	Minimum Flight Speed in Landing Configuration
VSWR	Voltage Standing Wave Ratio

## Appendix C-1 Legacy Transponder App Note

This is the simplest configuration and uses the power transcoder. SETUP is performed over Wi-Fi from an Android or iOS device. CONTROL, SQUAWK and Barometric ALTITUDE is decoded from the Legacy Transponder interrogation replies through the aircraft electrical system. A compliant GPS source such as a Garmin GPS 20A, Dynon SV-GPS-2020 or uAvionix skyFYX provides the position source for UAT transmissions. Traffic and Weather can also be displayed on the Android / iOS device via Wi-Fi.

Configure the echoUAT as follows for legacy transponder.

Setup Source	Control Source	GPS Source	Traffic	COM1 Rate	COM1 Data	COM1 Phy	COM1 Protocol	COM2 Rate	COM2 Protocol
APP	Transponder Monitor	External COM2	MFD COM2	N/A	N/A	N/A	N/A	115200	NMEA

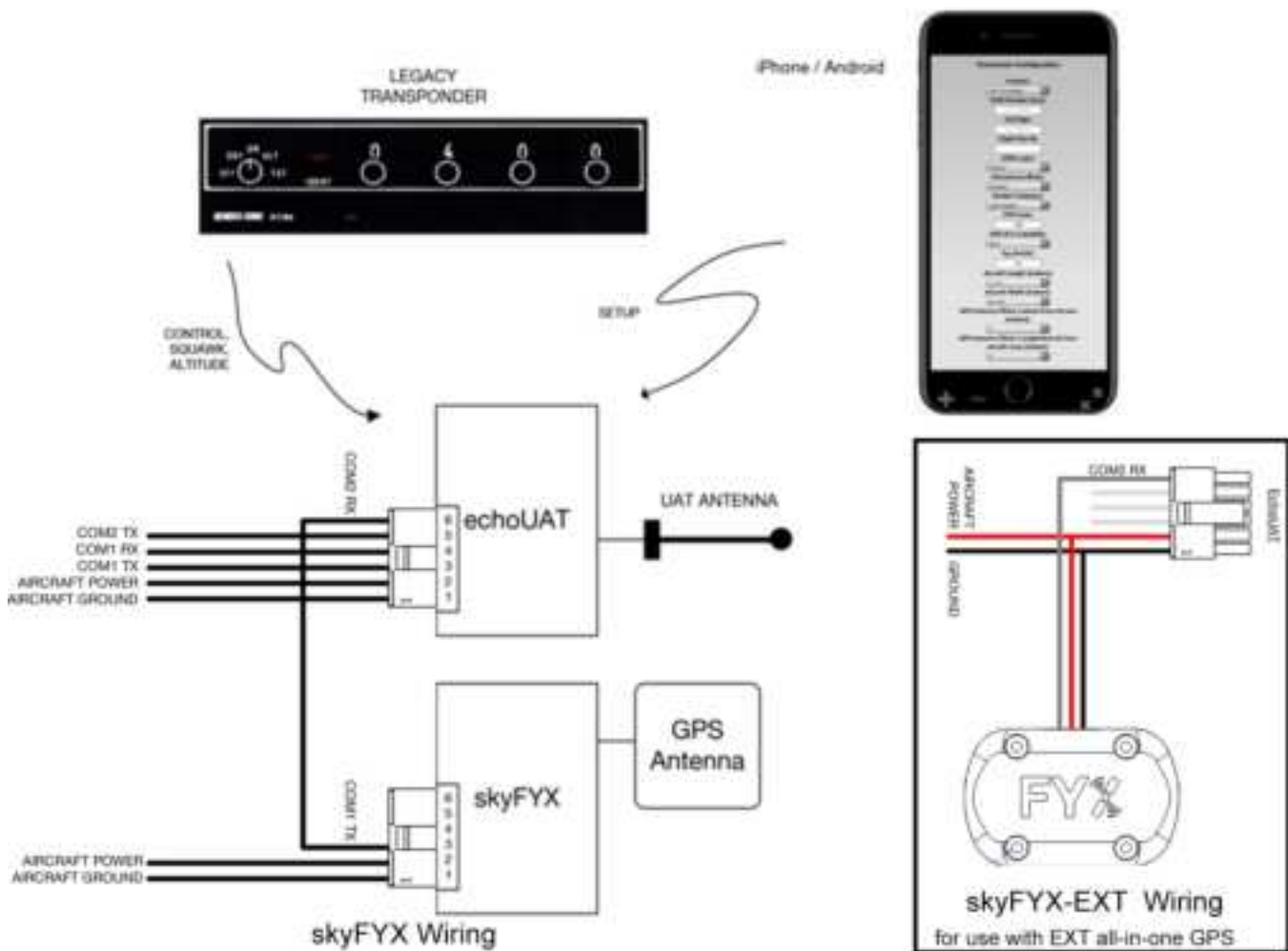

**Appendix C-2 GRT EFIS App Note  
GRT EFIS with SafeFly 2020 GPS App Note**

The GRT EFIS exchanges Setup, Control and GPS data with the echoUAT. The echoUAT can also send ADS-B traffic and uplink data to GRT EFIS.

**EchoUAT app settings:**

If your transponder is controlled by the GRT EFIS:

Setup Source	Control Source	GPS Source	Traffic	COM1 Rate	COM1 Data	COM1 Phy	COM1 Protocol	COM2 Rate
EFIS	EFIS	EFIS COM1	MFD COM2	38400	81O	RS232	TMAP	115200

If your transponder is panel mounted:

Setup Source	Control Source	GPS Source	Traffic	COM1 Rate	COM1 Data	COM1 Phy	COM1 Protocol	COM2 Rate
EFIS	Transponder Monitor	EFIS COM1	MFD COM2	38400	81O	RS232	TMAP	115200

**GRT EFIS Settings:**

**General Setup:**

Serial Port X\* In: Safe-Fly GPS and SPC  
 Serial Port X\* Out: Safe-Fly GPS ans SPC  
 Serial Port X\* Rate: 115,200  
 SAVE

\*Serial port "X" refers to the serial port on the EFIS that is wired to the "Serial Control In/Out" of the Safe-Fly GPS module.

SPC Serial Port 1 Rate: 38400  
 SPC Serial Port 1 Output EchoUAT/TMAP  
 SPC Serial Port 1 Input EchoUAT/TMAP

Serial Port Y\* In ADS-B  
 Serial Port Y\* Rate 38,400 if connected to SafeFlySPC or 115,200 if connected to EFIS  
 SAVE

Serial port "Y" refers to the serial port used to receive ADS-B data into the EFIS. For best performance the ADS-B In (Pin 5) on the EchoUAT should be wired directly to a high speed port on the EFIS and not connected to the serial combiner on the SafeFly GPS. If wiring through the SafeFly we recommend a baud rate of 38,400. If wiring directly to the GRT EFIS we recommend 115,200.

**GRT EFIS Setup Continued:**

**General Setup: Flight ID and Address**

Flight ID: (leave blank)  
Mode S Code: Enter ICAO code or six digit Mode S code from registration  
SAVE

**General Setup: TT22/EchoUAT**

Aircraft Category: Light Aircraft (less than 15,000lbs takeoff weight)  
Aircraft Width: Enter width in meters  
Aircraft Length: Enter length in meters  
VFR ID: Enter Tail or N-Number  
GPS Input: Compliant TMAP  
GPS Rate: 9600  
Test Squitters: Never  
TIS Output: Off  
UAT/978 Receiver: Yes  
1090ES Receiver: Yes  
GPS Antenna Offset Linear: Enter GPS longitudinal offset in meters from nose  
GPS Antenna Offset Lateral: Enter GPS lateral offset in meters  
SAVE

Once all settings are complete the Echo App monitor screen should display the same parameters as entered into the GRT. Verify all fields are populated prior to flight.

## Example Wiring:

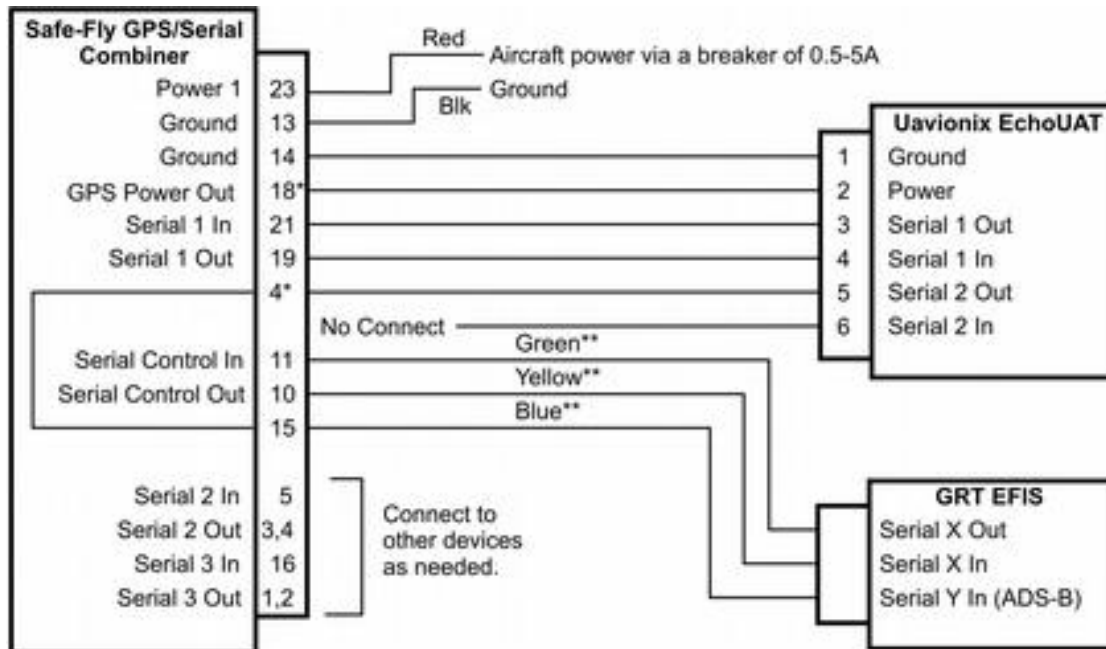

\*Rev A Safe-Fly, identified with red on label, does not support these connections. Connect EchoUAT pin 2 to aircraft power, and pin 5 directly to EFIS serial input.

\*\*For GRT Sport and Horizon HS/WS EFIS, the green wire is not connected. The yellow wire is connected if you wish to supply the EFIS with the Safe-Fly GPS position data. The blue wire must connect to the high-speed serial input, which is serial port 4 for these units to display ADS-B weather and traffic data.

## Safe-Fly to EchoUAT Pre-Wired Cable

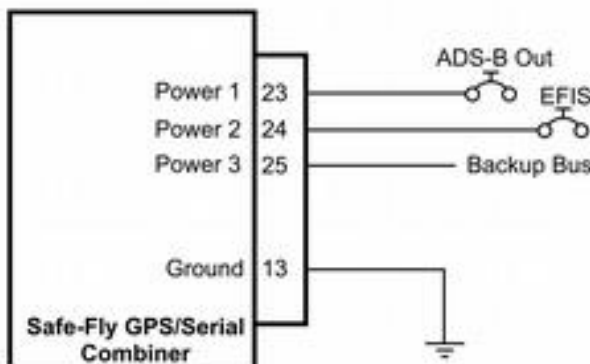

This method of powering the Safe-Fly GPS (and EchoUAT) provides power to them whenever any power input is active.

Safe Fly to EchoUAT wiring diagram Rev C.odt

## Typical use of multiple power inputs

## Appendix C-3 Dynon Skyview EFIS App Note

The Skyview exchanges Setup, Control and GPS data with the echoUAT. The echoUAT does not exchange ADS-B Weather and Traffic (GDL-90) data.

Equipment	Setup Source	Control Source	GPS Source	COM1 Rate	COM1 Data	COM1 Phy	COM1 Protocol
Dynon Skyview	EFIS	EFIS	EFIS	38400	81O	RS232	TMAP

### Setup / Control

#### SYSTEM SETUP

##### SERIAL PORT SETUP

##### SERIAL PORT 1 SETUP

##### SERIAL IN DEVICE

SELECT: DYNON SV-XPNDR-262

#### TRANSPONDER SETUP

GPS DATA: DYNON SV-GPS-2020

TRANSPONDER HEX CODE: enter the ICAO hex number of the aircraft

VFR CODE: enter the default VFR squawk code (1200 for the US)

AUTO ALT/GND: AUTOMATIC (AIR DATA)

AIRCRAFT CATEGORY: select the appropriate aircraft category

AIRCRAFT LENGTH: the length of the aircraft in ft

AIRCRAFT WIDTH: the width of the aircraft in ft

MAXIMUM CRUISE SPEED: select the appropriate cruise speed range

TIS TRAFFIC: OFF

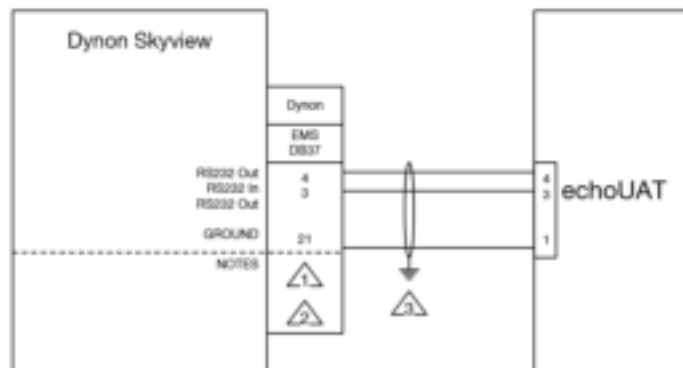

-  WIRING TO BE 22 AWG
-  THE SKYVIEW HAS 5 RS232 CHANNELS. ANY OF THESE CAN BE USE TO CONNECT TO THE echoATU
-  GROUND AT THE EFIS

## Appendix C-4 Apollo SL70 App Note

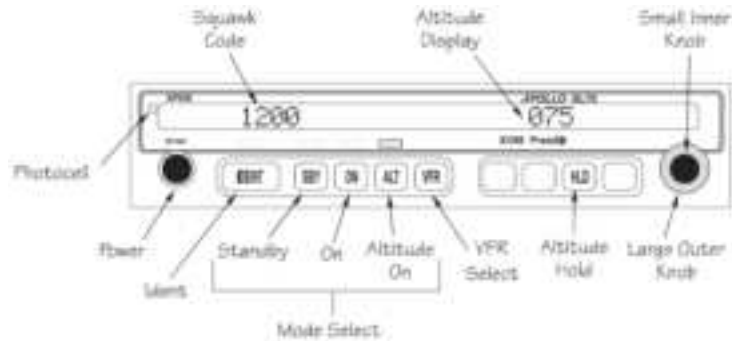

The Apollo SL70 outputs Altitude, Mode, Squawk and Mode C code over RS232. The configured baud rate needs to be determined and programmed into the echo app.

Determine the baud rate of the serial port as follows:

The SL70 has a built-in setup mode to simplify the checkout. To operate the SL70 in the setup mode, hold down the “IDENT” and “ALT” buttons while switching on the power. To return to normal operation, switch the power off, then back on.

RS-232 Baud Rate Determination.

To view the baud rate: In test mode, rotate the LARGE knob to the “SL70 CONF” (SL70 Configuration) page, then rotate the SMALL knob to the “BAUD” (baud rate) page. The baud rates available are 1200, 2400, 4800, 9600, and 19200. The TX setting must be configured to EXT for squawk to pass to the echoUAT.

Equipment	Setup Source	Control Source	GPS Source	COM1 Rate	COM1 Data	COM1 Phy	COM1 Protocol
SL70	APP	Panel	COM2	9600	81N	RS232	GDL

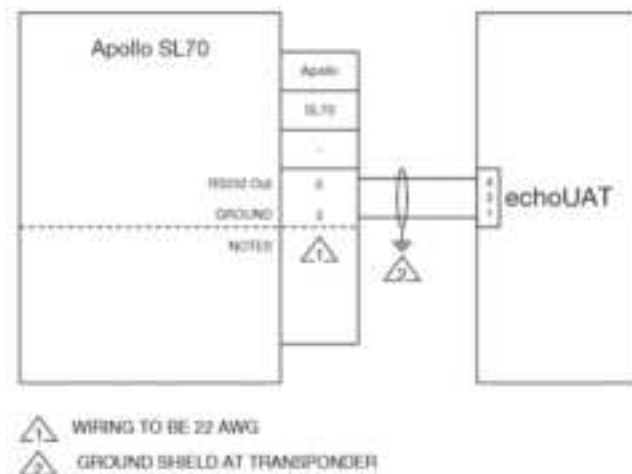

## Appendix C-5 Sandia STX165/R App Note



The STX165 outputs Altitude, Mode, Squawk and Mode C code over RS232. The baud rate, if fixed, and needs to be programmed into the echo app.

Equipment	Setup Source	Control Source	GPS Source	COM1 Rate	COM1 Data	COM1 Phy	COM1 Protocol
STX165	APP	Panel	COM2	9600	81N	RS232	GDL

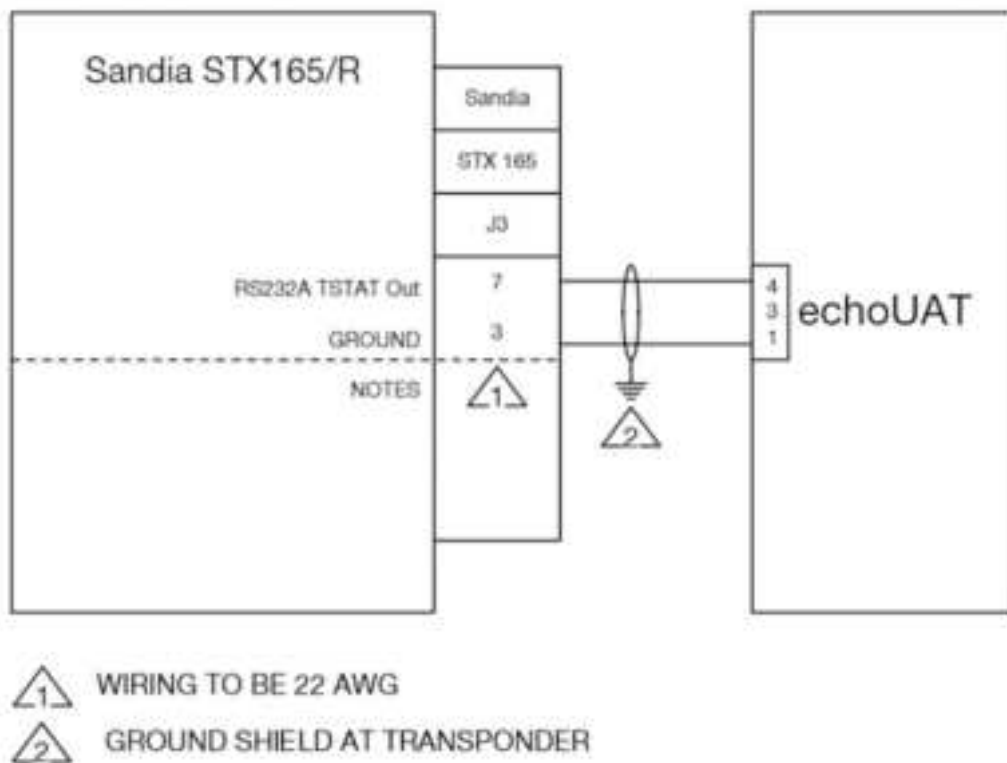

## Appendix C-6 Garmin GTX32/327 App Note



The GTX327 outputs Mode, Squawk code over RS232. The baud rate, if fixed, and needs to be programmed into the echo app. Pressure altitude is decoded via the power transponder or optional echoUATmux wiring harness. The RS232 OUTPUT must be set to “REMOTE”.

Equipment	Setup Source	Control Source	GPS Source	COM1 Rate	COM1 Data	COM1 Phy	COM1 Protocol
Garmin GTX327	APP	Panel	COM2	9600	81N	RS232	GTX

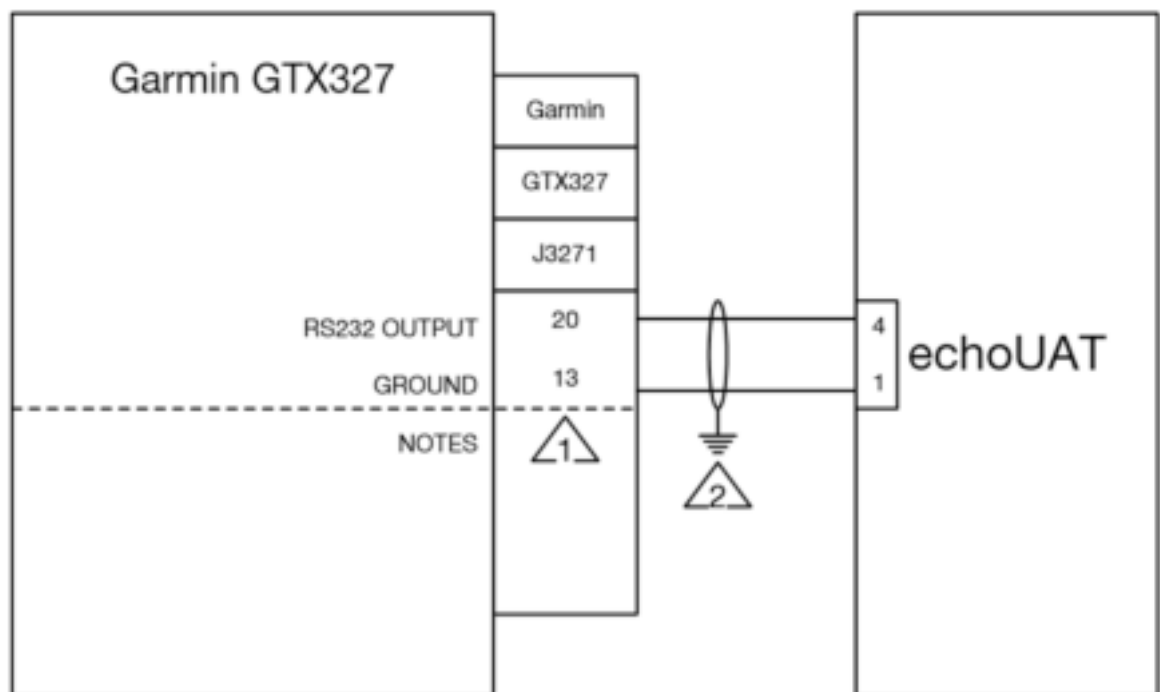

- 1 WIRING TO BE 22 AWG
- 2 GROUND SHIELD AT TRANSPONDER

## Appendix C-7 MGL EFIS App Note

The MGL EFIS Controls the echoUAT.

At time of writing, (iEFIS G3 version A.1.0.3.4) integration with MGL is in process. EFIS setup and EFIS GPS will be available once the integration is completed. We currently recommend configuration using the echo mobile application. Wire traffic to the EFIS per MGL guidance.

Equipment	Setup Source	Control Source	GPS Source	Traffic Uplink	COM1 Rate	COM1 Data	COM1 Phy	COM1 Protocol
MGL	APP	EFIS	COM2	COM2	38400	810	RS232	TMAP

### Menu

System setup menu

Serial port 1 (Internal): Ping Transponder

Transponder setup menu

Type: Ping Mode-S on RS232

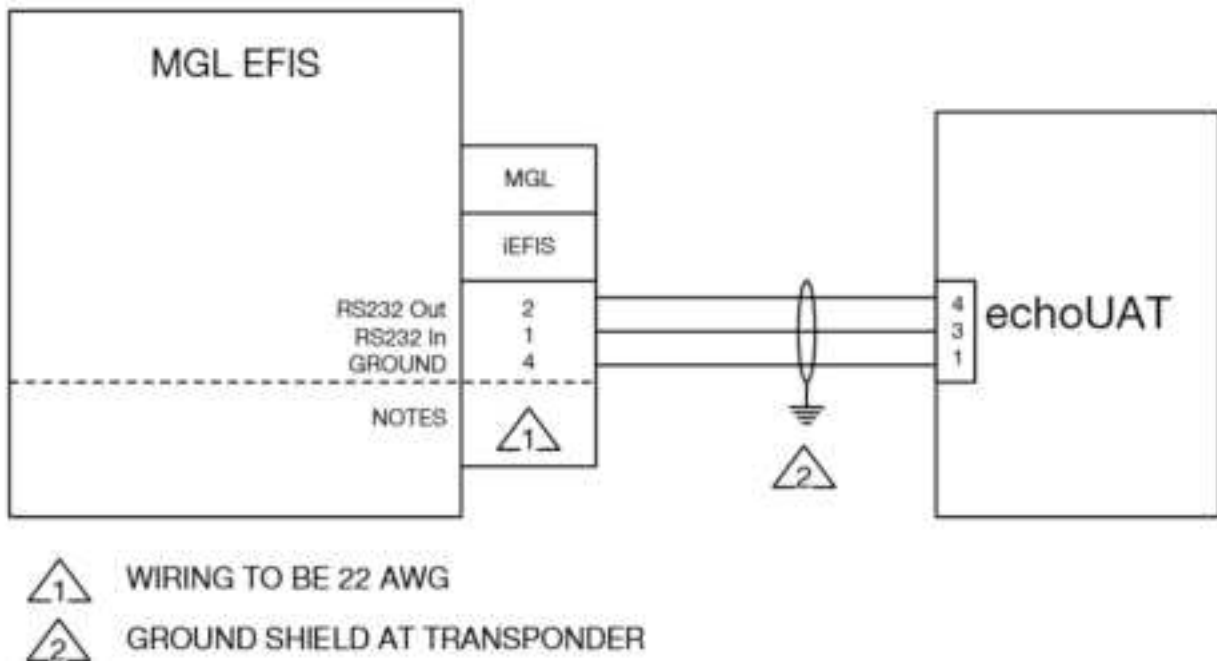

## Appendix C-8 AFS Advanced Flight Systems EFIS App Note

AFS EFIS models that support GDL90 traffic can receive traffic and weather from the echoUAT. Some supported models are the 3400S, 4000 and 5000 series.

The configuration requires the echoUAT pin 5 (COM2 TX) is connected to an available serial RX port on AFS EFIS. If using a Garmin GPS source connect pin 3(COM1 TX) on the echoUAT.

Weather and traffic are also supported using the AFS wireless adapter.

**Note:** No configuration of echoUAT is required for wireless traffic

The AFS serial port should be configured for ADSB115K

The echoUAT should be configured to send traffic and weather to the AFS EFIS by setting the following settings in the echo installer mobile application.

**For installations on echoUAT COM2 (pin 5)**

Equipment	Setup Source	Control Source	GPS Source	Traffic Uplink	COM2 Rate
AFS EFIS	APP	As required	As required	COM2	115200

**For installations on echoUAT COM1 (pin 3)**

Equipment	Setup Source	Control Source	Traffic / Uplink	COM1 Rate	COM1 Data	COM1 PHY	COM1 PROTOCOL
GDL90 EFIS, GRT, AFS, ETC	APP	As required	EFIS COM1	115200	81N	RS232	GDL90

Verify that the ADSB unit is talking to the EFIS. The CHECK -> ABOUT EFIS page will display the ADSB OSHIP messages (scroll down). The OSHIP message counter should be counting up.

## Appendix C-9 Garmin GNS 4XXW-530W GPS App Note



The GNS 400W-530W series supports Garmin ADS-B+ output.

The following software requirements are necessary to use the GNS 400W-530W as a rule compliant position source.

*400 SERIES: GNS 400W / 420W / 420AW / 430W / 430AW*

*500 SERIES: GNS 500W / 500W TAWS / 530W / 530W TAWS / 530AW / 530AW TAWS*

*Main software version 5.03 or later and GPS software version 5.0 or later*

*Software updates are available from your local Garmin supplier*

*Note this information does not apply to the GNS480*

### Serial Connection

The GNS series has 4 serial ports for use with various avionics. EchoUAT needs a single wire from one of the available RS-232 Out on the Garmin to Pin 6 the Echo.

The connector on the 400 Series is P4001

The connector on the 500 Series is P5001

(View looking at rear of unit)

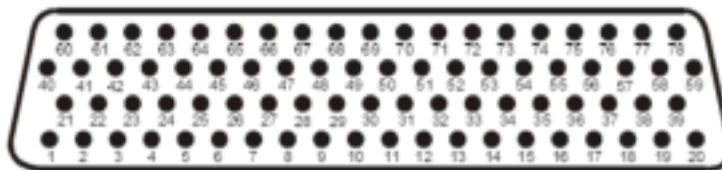

Pin	Pin Name
41	GPS RS-232 Out 3
54	GPS RS-232 Out 4
56	GPS RS-232 Out 1
58	GPS RS-232 Out 2

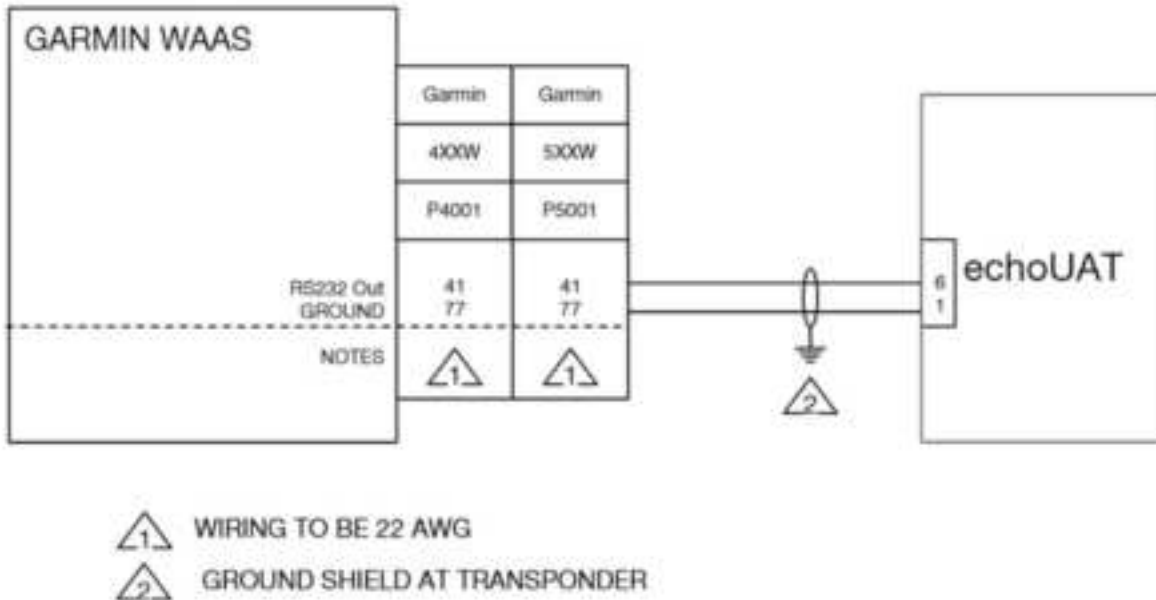

Pin 41 is shown as example for output on GPS Out 3. Pins 54, 56 or 58 can be used as alternates.

After wiring is complete configure the GNS to send ADS-B+ to Echo as follows:

Power on the GNS and press and hold the ENT key and turn the unit on. Release the ENT key when the display activates. After the GNS has completed startup you can access the port configuration using the right-hand knob.

Configuration pages can be accessed by ensuring the cursor is off and rotating the small right knob.

To change data on the displayed Configuration Page, press the small right knob (CRSR) to turn on the cursor. Rotate the large right knob to change between data fields. Rotate the small knob to change a field that the cursor is on. Once you have made the desired selection, press the ENT key to accept the entry.

- Use the small knob to reach the MAIN RS232 CONFIG page
- Select the CHNL number that matches the pin Echo is wired to example pin 41= Out 3
- Select ADS-B+ for the Output Value
- Press Enter
- Power the GNS Off and then On

**Echo Installer Application Settings:**

Equipment	Setup Source	Control Source	GPS Source	COM2 Rate	COM2 Protocol
GNS 4xxW-5xxW	APP	As required	COM2	9600	ADS-B+

If using a Garmin GPS with the EchoUAT and an EFIS proceed to Appendix C11 Traffic on COM1 App note.

### Appendix C-10 Garmin GTN 6XX-7XX App Note



The GTN 6xx-7xx series supports Garmin ADS-B+ output.

The following software requirements are necessary to use the GTN 6xx-7xx as a rule compliant position source.

600 SERIES: GTN 625 / 635 / 650

700 SERIES: GTN 725 / 750

*Main software version 3.00 or later and GPS software version 5.0 or later*

#### Serial Connection

The GTN series has 4 serial ports for use with various avionics. EchoUAT needs a single wire from one of the available RS-232 Out on the Garmin GTN to Pin 6 the EchoUAT.

Connector P1001

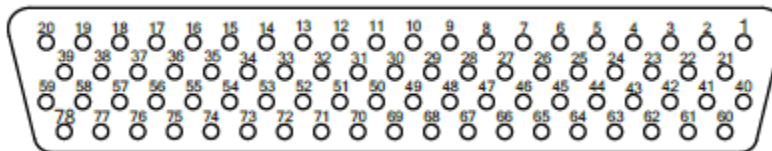

**LOOKING AFT  
TOWARD PILOT'S  
SEAT**

Pin	Pin Name
5	GPS RS-232 Out 4
6	GPS RS-232 Out 3
7	GPS RS-232 Out 2
8	GPS RS-232 Out 1

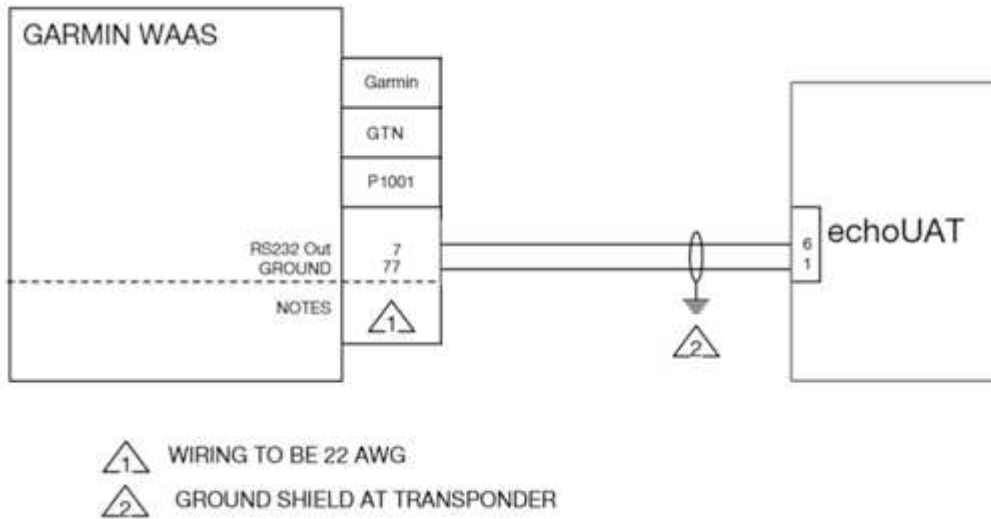

GTN Pin 7 is shown as example for output on RS-232 Out 2. Pins 5, 6, or 8 can be used as alternates.

After wiring is complete configure the GTN to send ADS-B+ to Echo as follows:

To access configuration mode, remove power from the GTN. With the GTN turned off (circuit breaker pulled), touch and hold the **HOME** key and reapply power to the GTN (push in the circuit breaker). Release the **HOME** key when the display activates and the name 'Garmin' appears fully lit on the screen. While in configuration mode, pages can be selected by touching the desired key on the display. Some pages may require page scrolling to view all of the information and keys on the page. This can be done by touching the screen and dragging the page in the desired direction, or by touching the **Up** or **Down** keys.

Startup the GTN in Configuration Mode

Tap RS232

Tap the Output that matches the GTN pin EchoUAT is wired to, example pin 7= Output 2

Select ADS-B+ for the Output Value. If two entries are available for ADS-B+ choose ADS-B+ format 1.

Press Back to return to the configuration mode home screen.

Power the GTN Off and then On

Configure the EchoUAT application to receive ADS-B+ data from the GTN.

**Echo Installer Application Settings:**

Equipment	Setup Source	GPS Source	COM2 Rate	COM2 Protocol
GTN 6xx-7xx	APP	COM2	9600	ADS-B+

If using a Garmin GPS with the EchoUAT and an EFIS proceed to Appendix C11 Traffic on COM1 App note.

## Appendix C-11 Traffic on COM 1 via GDL90 App Note

When EchoUAT is connected to a GPS source with a lower rate, traffic delivery to an EFIS on will also be impacted. To improve the responsiveness of traffic it can be optionally output on COM1 (Pin3).

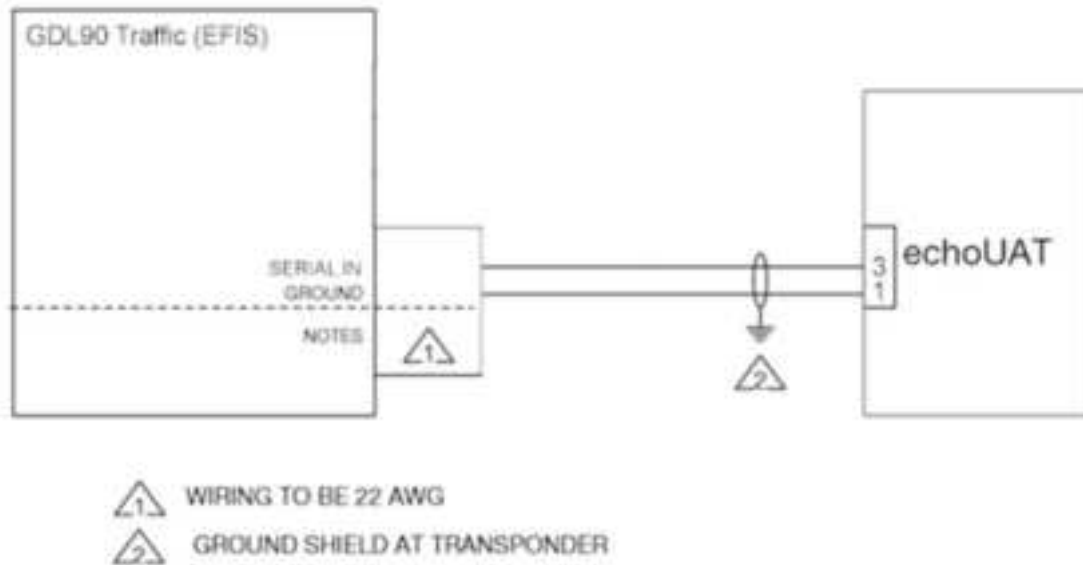

Note that in this configuration the EFIS cannot be set for control of the echoUAT

Settings for Traffic on COM1 are as follows:

Equipment	Setup Source	Control Source	Traffic / Uplink	COM1 Rate	COM1 Data	COM1 PHY	COM1 PROTOCOL
GDL90 EFIS, GRT, AFS, ETC	APP	Transponder Monitor	EFIS COM1	38400-115200	81N	RS232	GDL90

After EchoUAT is configured for COM1 Traffic the EFIS will need configured to receive the data.

As an example the GRT EFIS would be set to the following settings:

Serial Port Input: ADS-B  
Serial Port Rate: 115200

## Appendix C-12 echoUATmux harness for Navworx

The optional echoUATmux harness allows plug and play connectivity to aircraft previously wired for the Navworx ADS600EXP. The harness allows echoUAT to support a GTX327/GTX330 with a separate serial altitude encoder. Icarus, Garmin/Trimble, Northstar, Magellan formats are currently supported.

The pin out of the DB9 is shown below.

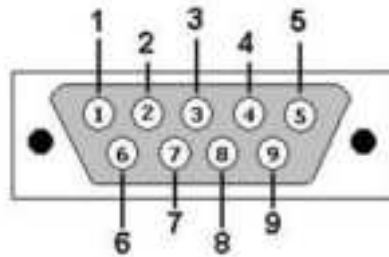

View looking into male connector

Pin #	I/O	Name	Description
1	I	GTX Transponder Control RX	RS232 RX Data from Transponder configured for Remote Mode
2	--	--	Not Used
3	I	Altitude Encoder RX	RS232 Altitude Encoder Input
4	--	--	Not Used
5	I	Aircraft Ground	Main Aircraft Power Ground
6	O	COM 1 Traffic TX	RS232 GDL90 to EFIS
7	O	COM 2 Traffic TX	RS232 GDL90 to EFIS
8	--	--	Not Used
9	--	Aircraft Power	Main Aircraft Power Input (+11 to +31VDC)

Configure the echoUAT as follows using the echo mobile application.

Equipment	Setup Source	Control Source	Traffic / Uplink	COM1 Rate	COM1 Data	COM1 PHY	COM1 PROTOCOL
GTX 327 RS-232 Encoder EFIS (optional)	APP	EFIS/Panel COM1	MFD COM2	115200	81N	RS232	GDL CONTROL