

AfiPass II

# Installation Guide

INNOVA  
REL  
EXP



**AfiPass**

Release Date | January 27, 2021

**afimilk**<sup>®</sup>  
Automating dairy farms





# Table of Contents

About this Guide and Scope .....	1
Intended Users .....	1
Conventions.....	1
Safety.....	1
High Power Safety Precautions.....	2
<b>1 Introduction .....</b>	<b>3</b>
<b>1.1 Principle and Flow of Operation .....</b>	<b>3</b>
<b>2 Prerequisite Considerations.....</b>	<b>4</b>
<b>2.1 General .....</b>	<b>4</b>
Software.....	4
Electrical Requirements .....	4
Environmental Specifications.....	4
ID Tag Requirements.....	4
<b>2.2 Parlor Electrical Grid - Grounding Requirements.....</b>	<b>4</b>
<b>3 Ordering Components .....</b>	<b>5</b>
<b>3.1 Ordering AfiPass II Controller System .....</b>	<b>5</b>
<b>3.2 Ordering Antenna .....</b>	<b>5</b>
<b>3.3 Sourcing Antenna Brackets .....</b>	<b>7</b>
<b>3.4 Ordering Transformers (Requirements) .....</b>	<b>7</b>
<b>3.5 Ordering Replacements Parts.....</b>	<b>8</b>
<b>4 Understanding Installation Workflow .....</b>	<b>9</b>
<b>5 Mounting the Components .....</b>	<b>9</b>
<b>5.1 Mounting the Antennas .....</b>	<b>10</b>
Positioning the Antenna.....	11
Positioning the Brackets.....	12
Attaching the Brackets .....	15
<b>5.2 Mounting the AfiPass II Controller.....</b>	<b>16</b>
AfiPass II Controllers – Mounting Locations .....	16
<b>5.3 Mounting Process.....</b>	<b>19</b>

<b>6</b>	<b>Laying the Cables</b>	<b>20</b>
<b>7</b>	<b>Wiring the System</b>	<b>22</b>
7.1	Grounding the System	22
7.2	Wiring Device #1	22
7.3	Inserting Cables into the AfiPass II Controller	22
7.4	Wiring the Cables to the Connectors	24
	AfiPass II Control PCB Layout	25
	AfiPass II Control PCB Connections	25
	Connectors and Functions	27
7.5	Finalizing the Wiring Connections	31
<b>8</b>	<b>Setting AfiPass II Addresses and Calibrating Antennas</b>	<b>32</b>
8.1	Opening Test Mode	33
8.2	Setting Device Addresses	34
8.3	Calibrating the Antennas	35
8.4	Setting Transmission Power and Reception Range	36
8.5	Testing ID Range and Troubleshooting	38
8.6	Returning to Work Mode	39
<b>9</b>	<b>Configuring the System</b>	<b>40</b>
<b>10</b>	<b>Using AfiPass - First Time</b>	<b>42</b>
10.1	Gates Indicators	43
<b>11</b>	<b>Identifying Faults and Troubleshooting</b>	<b>44</b>
<b>APPENDIX 1</b>		<b>45</b>
	Cable Chain for Vertical Lift Chest Bar Stall Work	45
	Cable Chain Length Calculations	45
<b>APPENDIX 2 – DIP Switch</b>		<b>47</b>
	Contacting Technical Support, Help Desk	49
	Legal Notice	49
<b>Certification</b>		<b>50</b>

## About this Guide and Scope



This guide describes the pre-installation, installation, startup and troubleshooting procedures for AfiPass II.

AfiPass II is the next generation ISO ID system, integrated inside Afimilk systems. This new system substitutes the previous – AfiPass I ID system.

## Intended Users

This guide is intended for Afimilk™ dealers' technicians and qualified personnel.

## Conventions

-  **Warning: Actions requiring special attention to avoid serious physical injury. For example, working with high voltage components.**
-  **Caution: Actions requiring special attention, to avoid possible damage to equipment or livestock.**
-  **Note: Recommendations for working efficiently.**

## Safety

-  **Warning: Do not dispose of WEEE as unsorted municipal waste!**
- Read this manual carefully. Proper handling of the equipment is the basis for correct functioning.
- The AfiPass II device is installed and tested at the milking parlor by a qualified technician authorized by Afimilk.
- The customer is fully responsible for any changes made, either in the system configuration or in the software application data, by the customer or by the customer's agent.
- Afimilk will not be held responsible directly or indirectly for any damage caused to the customer and/or to a third party and/or to the animals, by an action and/or change and/or omission performed in the AfiPass II system and/or in the milking device, either by the customer or by the customer's agent, directly and/or indirectly.
- Afimilk recommends that the customer call for a full system inspection by a qualified technician authorized by Afimilk every six months.
- The device is intended for indoor installation only.
- It is the user's responsibility to install, operate, and maintain the system in accordance with all applicable codes, regulations, and safety measures.
- Any person installing and operating AfiPass II must be authorized to do so, after receiving appropriate training for proper usage of the machine and equipment and all related risks.
- Never install AfiPass II if you are not sufficiently authorized and trained to do so, nor allow it to be used by unauthorized persons.

- Do not flush the electrical or electronic equipment with water or any other liquid.
- It is the responsibility of the operator to operate and maintain the system in accordance to all applicable local codes, regulations, by-laws, and safety regulations.
- Disconnect power before servicing.

### **High Power Safety Precautions**

- High voltage transients, surges, and lightning can cause extensive damage to equipment, people and livestock. It is the installer's responsibility to provide a power protection system to protect the system from these and other power irregularities.
- Make sure that all electrical connections, including grounding of the metal structure, are properly performed by a qualified electrician.
- Compliance with FCC standards is conditional upon the system being installed in accordance with the formations in which the product passed the standards tests, and the declarations given to the authorities. Any changes or combination made in the system, other than those defined, will not be approved by the standards and is referred to accordingly.
- Operate the system under conditions that comply with the declaration of conformity, the T.C.F., and the test reports in these documents.
- The transformer should be UL/CSA certified.
- The transformer is not provided with the equipment. Installation shall be performed by a certified electrician in accordance with the National Electric Code (NEC) and local codes. It is the responsibility of the installer that equipment be powered from an external UL/CSA certified transformer of appropriate rating.

# 1 Introduction

AfiPass II™ is an ISO (Passive) identification system integrated into the AfiFarm herd management system. AfiPass II is based on the principle of radio frequency identification (RFID) and refers to automatic identification of animals using ISO 11874/5 compatible passive ID tags (without batteries). AfiPass II supports a per stall ID system and walk through ID systems per the configurations officially released by Afimilk. AfiPass II supports the following setups:

- Parlor stall ID - per the defined models of:
  - Herringbone,
  - Parallel.

● **Note: Sort gates based on AfiPass II will be released soon.**

● **Note: Until specifically announced, AfiPass II may NOT be installed in Rotary Parlors.**

## 1.1 Principle and Flow of Operation

The AfiPass II system communication steps are:

1. The AfiPass II Controller sends an ID request signal via an antenna.
2. The ID request signal energizes a transponder in an identification tag.
3. The identification tag responds with a unique ID number back to the antenna.
4. The antenna receives the tag transmission and relays it back to the AfiPass II Controller.
5. The AfiPass II Controller relays the tag ID number to the AfiFarm herd management system.
6. AfiFarm uses the ID number for controlling AfiFarm stations and for data collection - herd management.

## 2 Prerequisite Considerations

### 2.1 General

#### Software

AfiPass II is only compatible with AfiFarm 5.4 and above.

#### Electrical Requirements

Designation	Requirement
Rated Voltage	24 VAC Nominal (single phase)
Input Voltage Range	20.4-27.6 VAC
Rated Frequency Range	50/60 Hz
Input Current Range	0.7-1.5 Amp AC
Max Power Consumption	36 VA

#### Environmental Specifications

Designation	Requirement
Temperature	Operation: -20° to +50° C (-4° to +122° F)
	Storage: -40° to +85° C (-40° to +185° F)
Humidity	Operation: up to 80% RH without condensation
	Storage: up to 85% RH without condensation

#### ID Tag Requirements

All cows on the farm must have their tags attached to the ear on the same side. This is important for establishing the location of the antennas.

AfiPass II supports ISO standard HDX passive ID tag types (ISO 11784/5).

### 2.2 Parlor Electrical Grid - Grounding Requirements

- Potential difference between ground and zero:  $\leq \sim 0.6V$
- Spike:  $\leq \sim 0.9V$

## 3 Ordering Components

The equipment listed here refers to the AfiPass II ID system alone, not including other products required for the full Afimilk system, communications etc.

The equipment for ordering includes:





- AfiPass II controllers – per parlor size.
- AfiPass II antennas – per number of ID stalls and type of metal works.
- Other equipment required (may be sourced separately or locally).

### 3.1 Ordering AfiPass II Controller System

The number of AfiPass II Controllers required is determined by the number of ID stalls in the milking parlor.

Each device supports up to 5 stall antennas. Therefore, multiple AfiPass II Controllers are required to set-up a full milking parlor. All the Controllers are connected on a single daisy chain communication line, connected at the AfiFarm PC via its communication devices (AFiCom USB).

**Table 1 – AfiPass II System Components**

Picture	Name	Description	P/N
	AfiPass II Controller Assembly	Operates up to 5 antennas. Parlor gates may be connected to the controller.	4095910
	AfiCom USB4 Adapter Assembly	This may have already been ordered with the milk meters. If so, it is not necessary to re-order.	4193030
	AfiPass II Technician Tool	This tool is required for installing the AfiPass II system. It should be part of the toolbox of Afimilk installers.	4095921
	ID tags	Cow Ear Tag - HDX only May be sourced locally.	

### 3.2 Ordering Antenna

The AfiPass II antenna is a plastic rectangle. Each milking stall requires an individual antenna, which is mounted onto structures within the parlor (such as metal frames, or parlor walls).



For best results, the antenna should be mounted as close as possible to the cow's head, and as close as possible to the ID tag (the ear carrying the tag). However, it should also be mounted far enough from neighboring cows to avoid ID mistakes.

Before ordering antenna, conduct a survey of the site to determine which antenna type best suits the parlor (see Table 2). Selecting the antenna type will also need to take into consideration optimal mounting locations (see Chapter 5.1):

**Table 2 – Selecting AfiPass II Stall External Module 50 or 40**

AfiPass II Stall External Module 50	AfiPass II Stall External Module 40
The 50 cm antenna has a larger range; hence when there is enough space and the distance between the stalls is larger it should be used.	The 40 cm antenna should be used when there is not enough space to install the 50 cm antenna.
Mostly suitable for wall mounts and feeding troughs.	Mostly suitable for rapid exit parlors.
	The 40 cm antenna should be used when the distance between the stalls is small or lack separation, and there is a risk the larger antenna may interfere with antenna on next stall, or may read the tags on the cows in the neighboring stalls, or the cows finished milking and transferring through the exit passage.

**Table 3 – AfiPass II Antenna**

Picture	Name	Description	P/N
	AfiPass II Stall External Module 50	A 50 cm X 26 cm air loop passive antenna prewired with 15 m coaxial cable. Ferule type terminals included.	4095912
	AfiPass II Stall External Module 40	A 40 cm X 14.5 cm air loop passive antenna prewired with 15 m coaxial cable. Ferule type terminals included.	4095914

### 3.3 Sourcing Antenna Brackets

The antennas are mounted in the stalls using brackets that are designed and built to suit both the antenna size and the location where it will be mounted.

Custom made brackets are available for the most common parlor types. These are manufactured and sold directly from relevant companies.

- **Note: Custom-made brackets Antenna are available in the US market for the most common parlor types and are sold directly from relevant companies. Contact your local Afimilk representative for details.**
- **Note: All brackets are the dealer's responsibility to source (including manufacture and purchase), according to our guidelines. For further details, contact Afimilk support.**

### 3.4 Ordering Transformers (Requirements)

The AfiPass II system requires an isolating transformer that supplies power only to the AfiPass II Controllers. The size of this transformer depends on the number of controllers it powers.

- **Caution: The transformer must be supplied with suitable circuit breakers.**

The AfiPass II Controller uses up to 36VA during transmission (ID request) and 19VA during idle operation.

Controllers on the same side of the parlor will never transmit simultaneously, while Controllers on opposite sides might. Therefore, we recommend installing transformers on each side of the parlor to power the Controllers on that side.

To calculate the power requirements for each transformer, use the following formula:

$P = 36 + 19(N - 1)$ ; where:

- P = the transformer's required power rating in VA (Volt Amper)
- N = The number of controllers used.

For example: To power three devices a transformer with a power rating of  $P = 36 + 19 * 2 = 74 \text{ VA}$  should be used.

Transformer power rating [VA]	Number of devices allowed
75	3
100	4
200	9



Table 4 - Transformer

Picture	Name	Description	P/N
	Power transformer	230/24 -27 VAC OR 110/24 VAC. May be sourced locally.	5009401

### 3.5 Ordering Replacements Parts

The following can be ordered as required:

Table 5 – Ordering Replacements

Picture	Name	Description	P/N
	Rubber Stoppers Secures the AfiPass II Controller lid while open.	2 units in a package.	5001768
	Grommets for replacement (Each grommet has 3 inlets.)	5 Green units - for 6.5 mm (~¼") cables.	5001764
		2 Blue units - for 7.0 mm (~¼") cables.	5001763
	Grommet nuts for replacement	7 units in a package.	9020726

## 4 Understanding Installation Workflow

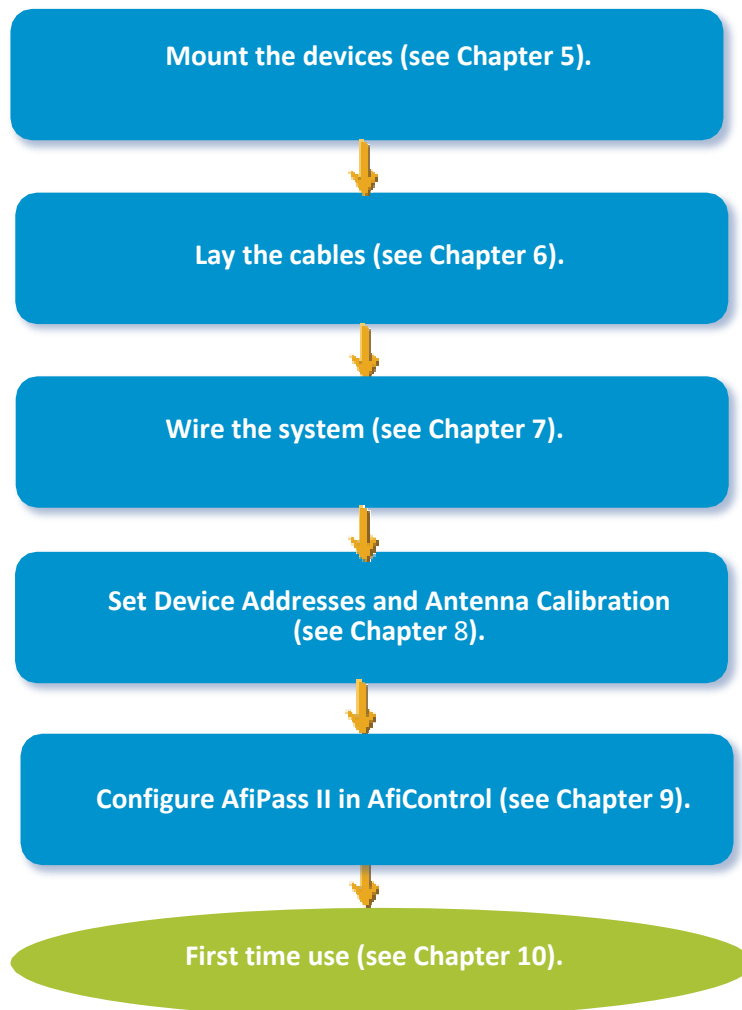

## 5 Mounting the Components

Mount the AfiPass II components according to the steps below.

### 5.1 Mounting the Antennas

Confirm the environment provides an option to mount the antenna, where the cables and antenna are protected from animals and surrounding elements (such as constant exposure to water/steam).

- **Note: Special consideration must be made to protecting the cables from animal licking and chewing. We recommend ducting the cables within the stall work itself.**

Before mounting the antenna, consider the following:

- The ear (left or right) on which the tags are located.
- The Stall type, size (specifically – the stall width), and structure.
- The location of the cow's head within the stall, and any movement restrictions to the cow's head while in the stall.
- The presence of metal loops, which substantially decrease the antenna's ID coverage. Antenna should not be mounted closer than 10 cm (in parallel) to any closed metal loops or plates in the parlor construction and metal works. Open structures (such as "U"-shaped) or perpendicular loops don't affect the range.
- Existing structures within the stall (for example, feeding troughs, chest bars, neck rail, overhead bars, walls).
- **Note: See Chapter 5 for examples of brackets on which to mount the antenna, and various mounting solutions for different parlor setups.**

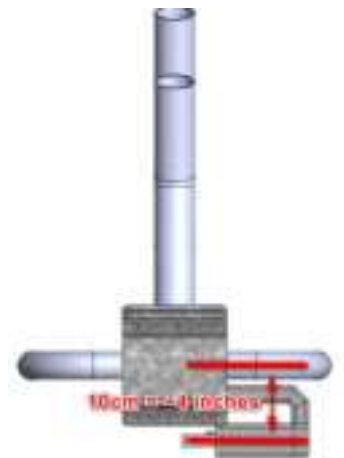

The antenna location and position varies according to the parlor type, metal works, Breast rail type, and position. Consequently, each mounting procedure depends on the current setup of the parlor.

## Positioning the Antenna

The antenna ID range can be controlled by changing the antenna orientation or adjusting the antenna transmission power.

Each side of the antenna projects a different range, as illustrated in Figure 1:

- **A** – illustrates the range projected from the front and back of the antenna.
- **B** – illustrates the range projected from the sides of the antenna.
- **C** – illustrates the range projected from the top and bottom of the antenna.

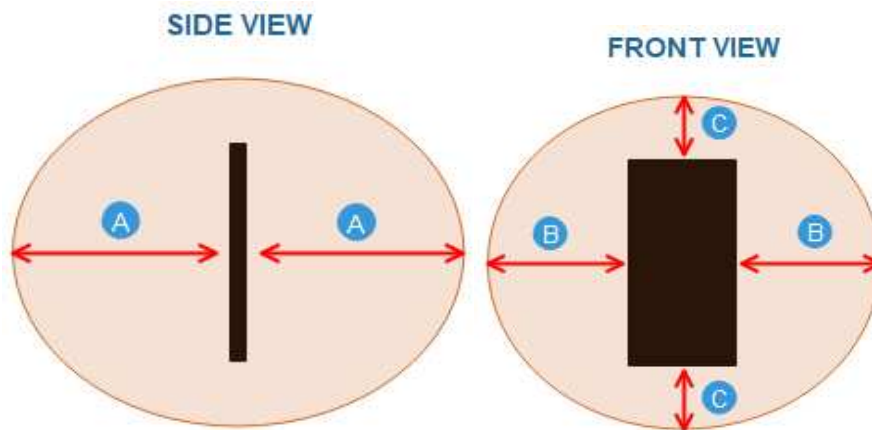

**Figure 1 – Antenna ID Range (Side and Front Views)**

Antenna range is adjustable via the AfiPass II Controller (see Chapter 8.4). Increasing the transmission power increases the ID range on each side of the antenna. In turn, this increases the distance available for the antenna to successfully detect the ID Tag. (However, it may also increase the risk of detecting incorrect tags of neighboring cows.)

Table 6 below illustrates how increasing the antenna transmission power increases the range projected on each side of the antenna. Table 6 also compares the different ranges available for the 50 cm and 40 cm antennas.

**Table 6 – Antenna ID Coverage Range for ISO ID Ear Tags**

Antenna Transmission Power	Side A		Side B		Side C	
	50 cm Antenna	40 cm Antenna	50 cm Antenna	40 cm Antenna	50 cm Antenna	40 cm Antenna
<b>Minimum Range</b>	25-30 cm (10"-12")	20-25 cm (8"-10")	16-22 cm (6"-9")	15-20 cm (6"-8")	12-16 cm (5"-6")	10-14 cm (4"-6")
<b>Medium Range</b>	55-60 cm (22"-24")	50-55 cm (20"-22")	35-40 cm (14"-16")	30-35 cm (12"-14")	28-32 cm (11"-13")	26-30 cm (10"-12")
<b>Maximum Range</b>	75-85 cm (30"-33")	65-70 cm (26"-28")	45-50 cm (18"-20")	40-45 cm (16"-18")	38-44 cm (15"-17")	34-38 cm (13"-15")





Front View



Side View



Top View

**Note:** In vertical lift rapid exit solutions, special consideration must be given to protecting the antenna cables from bending when the rail is lifted/lowered during operation, and from contact with the cows, see APPENDIX 1 for solutions to this.

**Example 2: Overhead Mounting in Parallel Parlor with Wall Mounted Feeders**

The example below illustrates brackets attached to a bar that runs across the top of the feeding troughs.

**Antenna Location**

The antennas are mounted as close as possible to the troughs, so that the ear tags come into range of the correct antenna while the cow eats from the trough.

**Bracket Attachment**



Antennas      Troughs



Antenna      Mounting Bar      Bracket

**Example 3: Herringbone (with/without Feed) without Rapid Exit**

In straight line parlors (with no Rapid Exit), side walls can be used for mounting the antennas in front of the cows' heads, so they are centered to the ears with the tags.

The antenna type and distance depend on the height of the cows and the side of the parlor they're located on.

On the parlor side where the ear tag sits further from the wall (See cows on the left side in the image at right), it may be advisable to use the 50 cm antenna to achieve a wider range. We also recommend using the 50 cm antenna in parlors without feeders and/or when there is constraining metal works below the cow's chest.

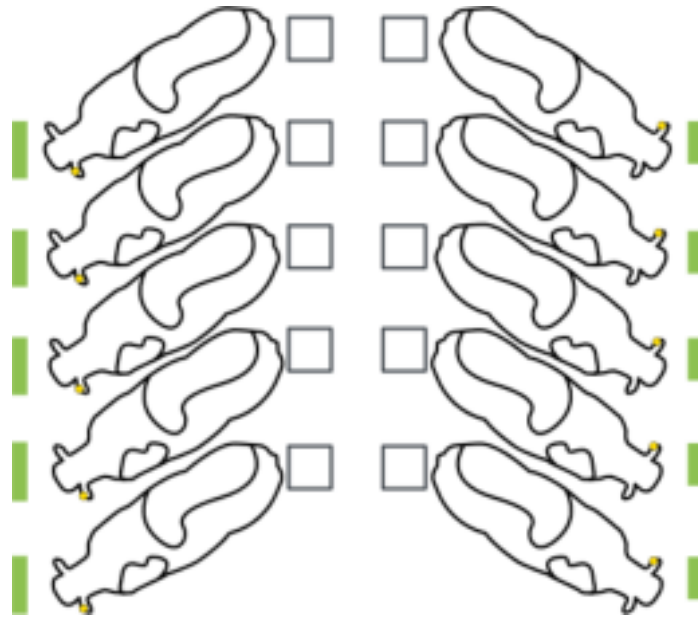

50 cm Antenna Bracket Design and Attachment for Wall Mounting



Herringbone Parlor – 50 cm antenna mounted on the wall.

### 40cm Antenna Bracket Design and Attachment for Wall Mounting

There are examples where it may be appropriate to use the 40 cm antennas on a wall mounting. If these antennas are used, position them at the cow's head height

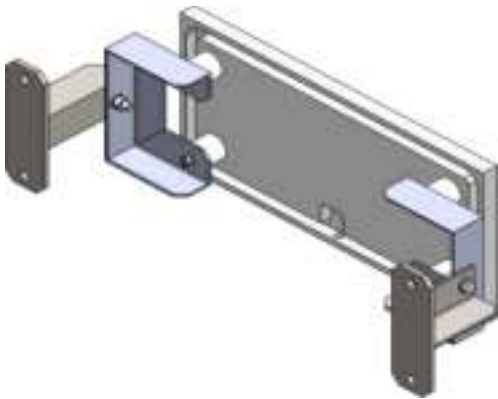

Herringbone Parlor – 40 cm antenna mounted on the wall.

### Example 4: Parlors with/without Feeders

The images below illustrate alternative antenna location options.

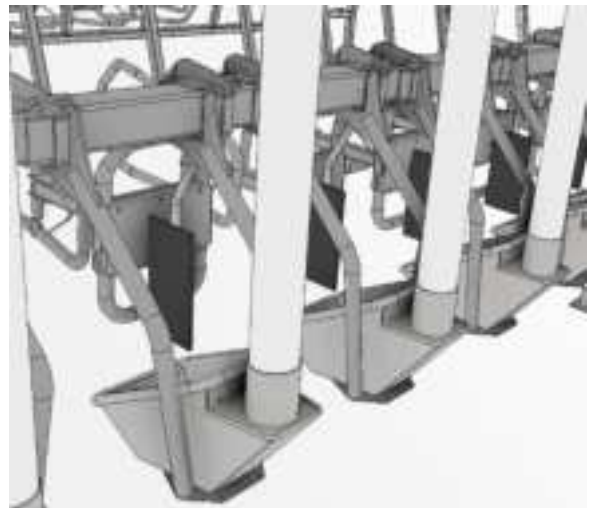

### Attaching the Brackets

Attaching the antennas to the brackets may require the technician to drill into the antenna plate. To avoid damaging the antenna, be very careful to only drill through the allowed section.

**Warning: Drill only within the drill area as shown below.**

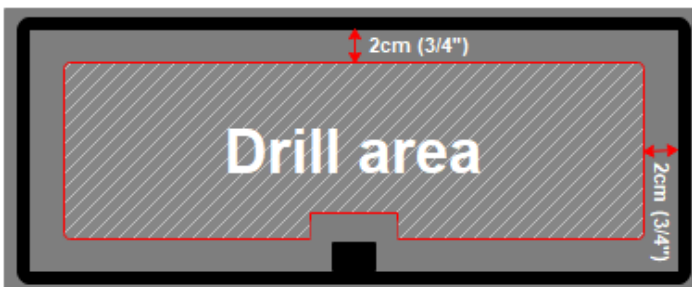

## 5.2 Mounting the AfiPass II Controller

Choose appropriate mounting locations for the AfiPass II Controllers. The locations should meet the following conditions:

- **Mounting stability** - the AfiPass II devices require a stable structure (such as a wall or overhead beam) on which to mount.
- **AfiPass II & Communication to PC** - communication lines can be extended up to 350-400 meters (383 – 437.5 yards).
- **Electrical interference** - Place the AfiPass II Controller and the antenna cables as far as possible from electric power lines or other electrical disturbances (especially from AC controllers, AC motors and Main power cables) to avoid electrical interference.

### AfiPass II Controllers – Mounting Locations

The AfiPass II Controllers are mounted in the parlor as follows:

**One controller** is mounted in the middle, between the two parlor sides. This will act as Device #1 (Main Display Device). Device #1 must be visible from the milking pit (to monitor the ID and gate status).

- **The rest of the controllers** are mounted according the number of milking stalls on each side. Device sequencing is based on sets of 5 antennas connected to each device, beginning from stall #1 which must be connected to Device #1 (Main Display Device). See mounting examples below.
- **Note: Regardless of which side of the parlor you choose to install the Main device, when your back is to the Main device, your left-hand side should always point to the 'low' stall numbers. This will ensure the corresponding entry/exit LEDs are on the correct side of the Main Device display.**

## Placement of Components

**Example 1 Layout:** Figure 3 shows the default system layout for a 2X12 Parallel parlor, where the number of stalls does not divide equally into groups of 5. The excess stalls on each side of the parlor are connected by default to a common device for both sides at the end of the parlor. This device is addressed as the last device in the parlor.

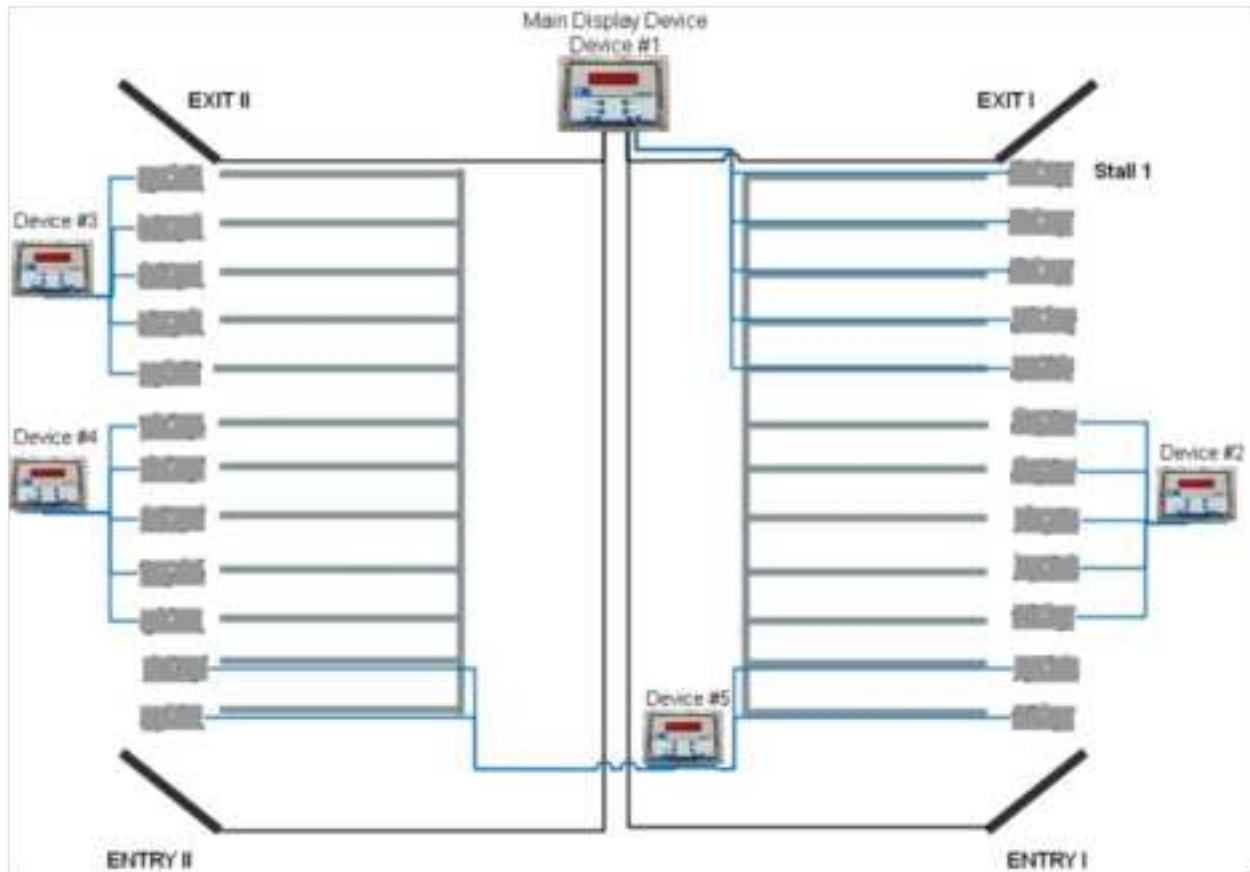

Figure 3 - Default Device Addressing of a 2X12 Parallel/HB Parlor

**Example 2 Layout:** In parlors where the number of stalls does not divide equally into groups of 5, and the excess number of stalls on both sides of the parlor exceeds 5 stalls, a device on each side should be installed (see Figure 4).

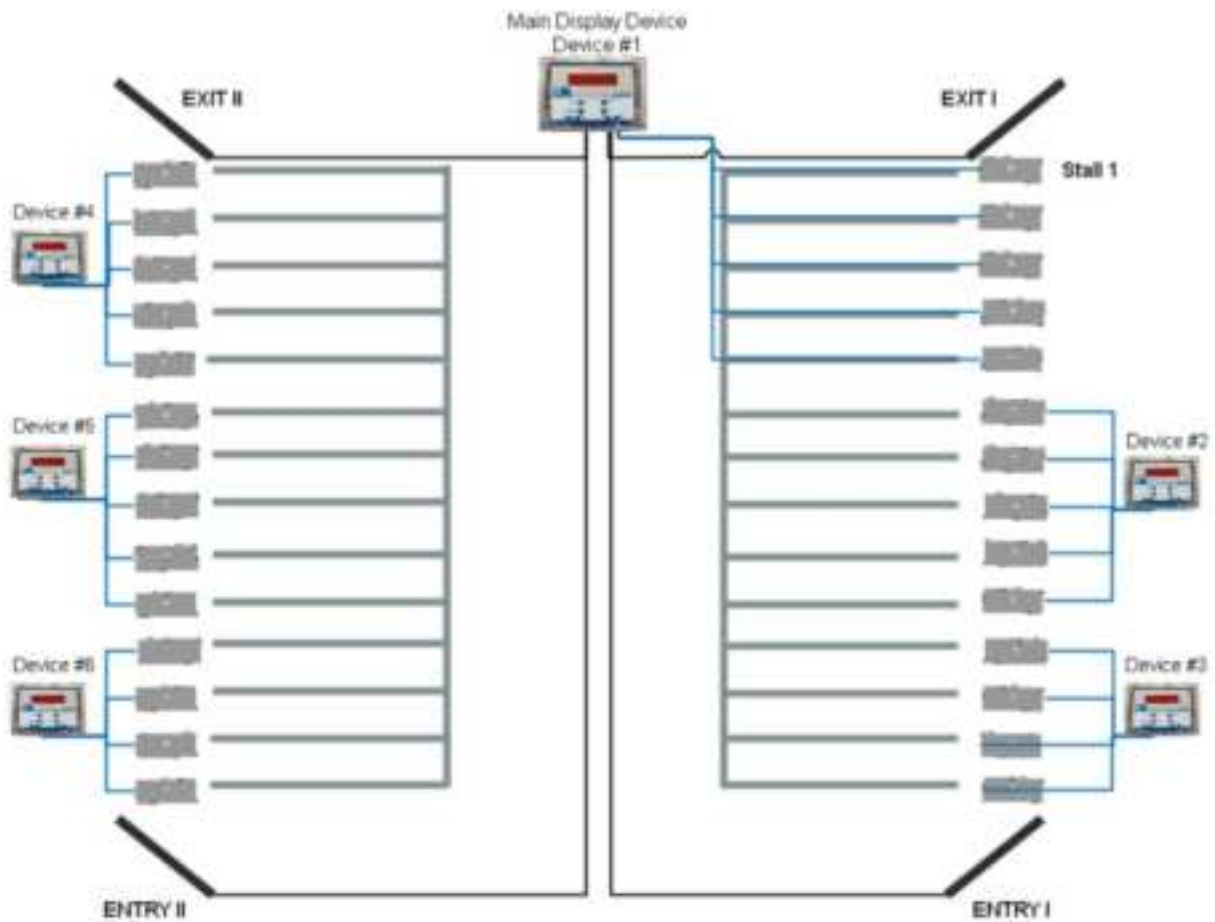

Figure 4 - 2X14 Parlor Layout Device Configuration (Example)

- Note: The parlor layout configuration can be changed manually in AfiControl to suit any required changes in the parlor.

### 5.3 Mounting Process

Every AfiPass II Controller is provided with two support plates on the back, see Figure 5 below. The box can hang from the support plates. Alternatively, the support plates can be attached to the box “upside-down”, and the plates can support the box above the point of attachment to the wall or beam. The latter method is useful in mounting the box on a beam with little overhead clearance, as the Box's cover opens upwards. The support plates protrude 6.5 cm ( $2\frac{5}{8}$ ”) from the edge of the box. An M6 bolt, washer, and two nuts are used to secure the support plates to the wall or beam.

#### To mount the AfiPass II Controller:

1. Attach the support plates to the box as shown in see below.

 **Caution: Mount the AfiPass II Controller on a stable, non-vibrating structure.**

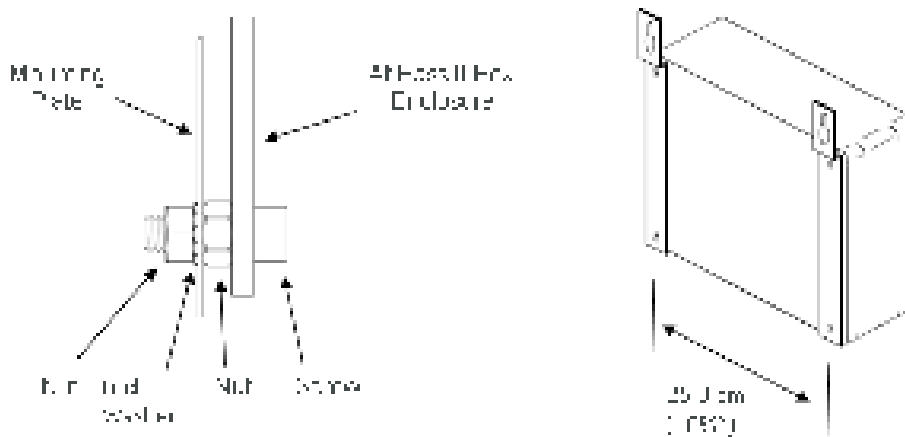

**Figure 5 - AfiPass II Mounting Equipment**

2. Bolt the AfiPass II Controller firmly to the wall or beam.

## 6 Laying the Cables

Use the appropriate cables and lay them according to your specific layout as described below.

- **Note: Lay the AfiPass II system cables in a separate cable trough designated for Afimilk systems service lines. Make sure the cables do not come close to other external cable systems, especially frequency convertors (VSD).**

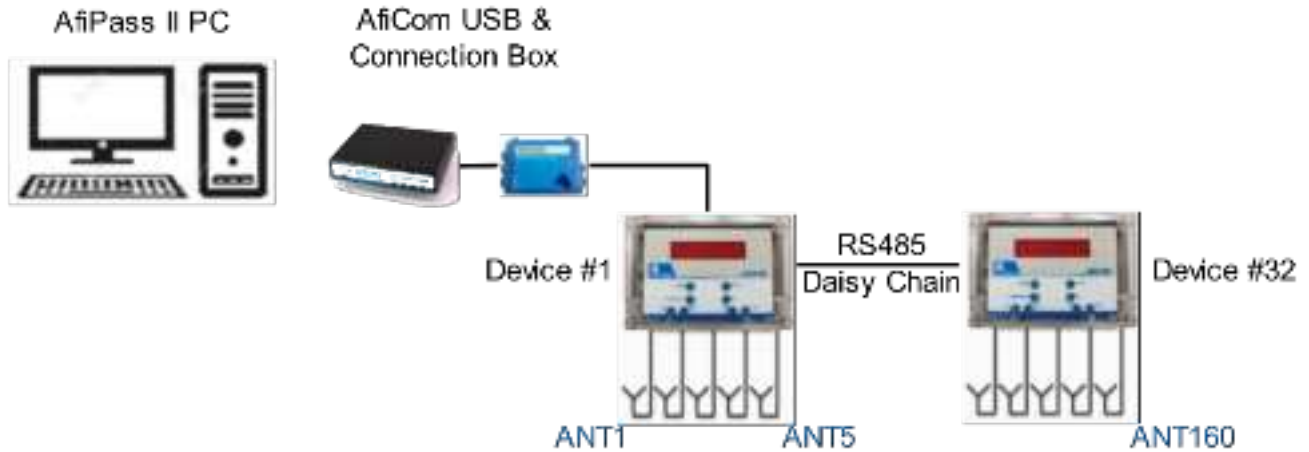

Figure 6 – System Communication Layout

Table 7 – AfiPass II Cable Requirements

Cable Type	Specification	From	To	P/N	Maximum Cable Length
Communication Cable	4-wire shielded cable 22AWG (0.3 mm <sup>2</sup> ) 120 Ω	AfiCom UB4 Connection box	AfiPass II Controllers	4097324	400m (437.5 yards).
Power Cable	2-wire cable, 18 AWG (0.75 mm <sup>2</sup> ). Cables must comply with <b>IEC standards 60332-1-2 and 60332-1-3</b>	Power Transformer	AfiPass II Controller	4000024	
Grounding Cable	Grounds the AfiPass II Controller (J3/3) to the metal structure.  Flexible 1-wire (2.5 mm <sup>2</sup> )	AfiPass II Controller	Parlor earthed (grounded) metal structure	4094079	
C1 Communication Cable	AfiCom USB C1 Communication Cable	USB4 Communication Adapter	AfiCom UB4 Connection box	4088212	

Cable Type	Specification	From	To	P/N	Maximum Cable Length
RF Signal Cable	Prewired to the antenna	Antenna	AfiPass II		15m (Do not reduce the cable length to less than 3m)

#### To lay the cables:

1. Lay the communication cable between the AfiPass II Controller and the computer.
2. Lay the communication cables between all the AfiPass II Controllers at the parlor.
3. Lay the power cable from the power transformer towards the AfiPass II Controllers.
4. Lay the prewired antenna cables from the antenna towards the AfiPass II controller.

**Note:** You can cut the cable to size to avoid slack. Minimum cable length = 3 meters.

**Cable length less than 3 meters may affect optimal antenna resonance resulting in decreased ID range and a possible malfunction of the system.**

## 7 Wiring the System

Once the transformers are installed and wired to the main power supply by a certified electrician. The AfiPass II Controllers are connected and wired according to the steps below.

### 7.1 Grounding the System

#### General Instructions for Grounding:

- **Verify the metal-structure is properly grounded** - A qualified electrician must verify that the milking parlor's metal work and mesh are grounded according to local and international standards. This can be done either to the mains power supply (if it is in proximity to the facility), or to a grounding rod (if the mains is distant and there is a possibility of potential difference due to the distance).
- **Use a short grounding wire to ground the AfiPass II** - Verify that the AfiPass II devices are grounded to the milking parlor's construction with the shortest cable possible, to avoid potential loss.

 **Caution: Incorrect grounding can harm animals and damage the ID system.**

### 7.2 Wiring Device #1



Device #1 acts as the Main Display Device, and the sensor cables for the entry and exit gates must be connected to this device.

Device #1 must also be connected to the antennas of stalls #1 to #5.

### 7.3 Inserting Cables into the AfiPass II Controller

Once the cables are placed, insert them into the AfiPass II Controller. AfiPass II Controllers are provided with color-coded grommets. Insert each cable through its appropriate grommet, as described below.

**Table 8 – AfiPass II Controller Cable Connections**

Cable Type	Grommet Color	Diameter	P/N
Antenna	 (Green)	6.5 mm (~¼")	5001764
Power, Communication & Gates	 (Blue)	7.0 mm (~¼")	5001763

**To insert a cable into the controller:**

1. Puncture the plug using a small screwdriver or any pointed object. Pull the loosened plug out of the grommet.

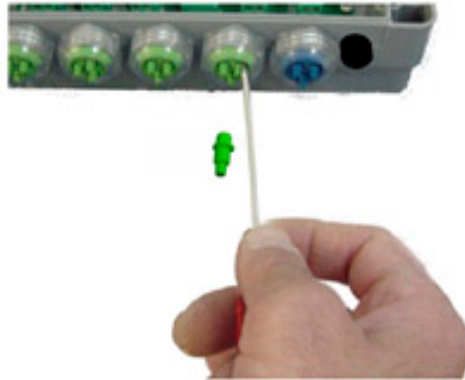

**⚠ Caution: Remove a plug only where a cable will replace it. If grommet holes are left open, the box will not be waterproof, and components may be damaged.**

2. Unscrew the nut and remove the grommet.
3. Thread the cable through the nut, and then through the grommet hole. Allow slack for wiring inside the box, allowing the box to open and close.

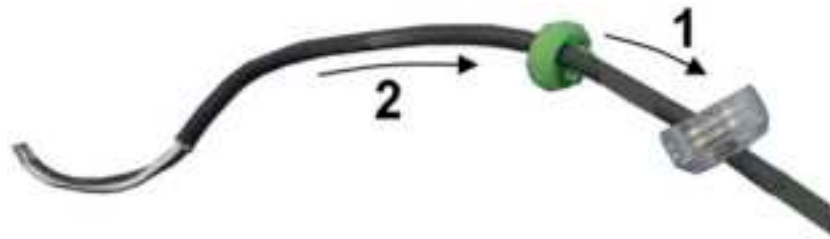

4. Insert the grommet into the socket.
5. Ensure the three small slots on the grommet are aligned with the pins in the cable inlet. This prevents the grommet from rotating when the nut is tightened. Rotate the nut one revolution on the threads, so that it is loosely held in position.



6. After inserting cables, connect the wires as described in the following section.

Table 9 – Grommet Usage

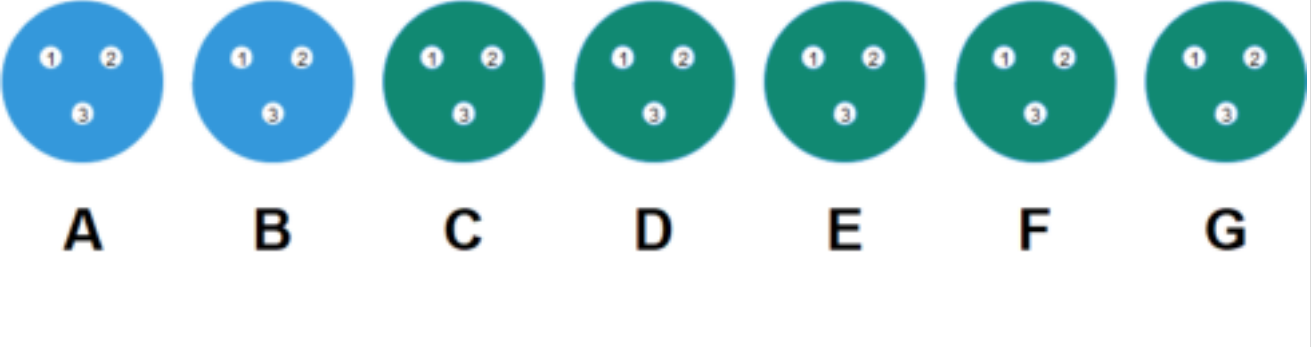

Grommet	Hole	Cable	Connector
A	1	24VAC Power	J10
	2	PC COMM. RS485 In	J1
	3	PC COMM. RS485 Out	J2
B	1	Gates Exit I	J4
	2	Gates Entry I	J4
	3	Gates Exit II	J5
C	1	Gates Entry II	J5
	2	Antenna 1	ANT1
	3	Grounding wire	Screw to PCB
D	1-3	Not used.	
E	1	Antenna 2	ANT2
	2	Antenna 3	ANT3
F	1-3	Not used	
G	1	Antenna 4	ANT4
	2	Antenna 5	ANT5

## 7.4 Wiring the Cables to the Connectors

The AfiPass II Controller is comprised of the following two separate Electrical PCBs (printed circuit boards):

- Control PCB mounted to the chassis of the controller's case.
- Display PCB mounted to the case's front panel. The two boards are connected via flat cable.

### AfiPass II Control PCB Layout

The control PCB is the main board of the device which contains all functional components and connectors.

The following figure shows the connectors and DIP switches on the AfiPass II Controller's Control PCB:

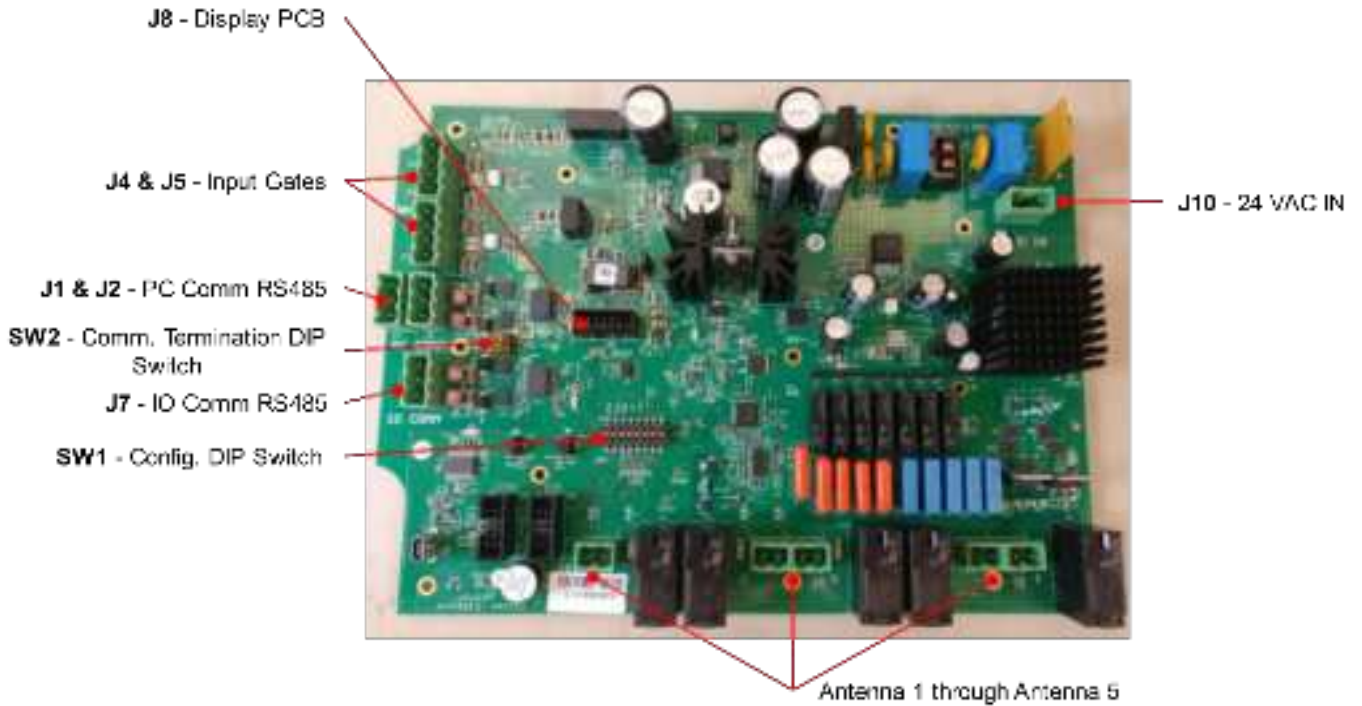

Figure 7 - AfiPass II Controller PC Board Layout

### AfiPass II Control PCB Connections

The connectors are numbered and have a prefix J.

Table 10 – Connections to the AfiPass II Controller

Connector	Cable	Connects to		Wires for Afimilk source cables	
		Device	Connection		
J1	Signal (3-wire)	PC Comm. In	PC RS485 communication	1	GND (Blue)
				2	B (White)
				3	A (Yellow)
J2	Signal (3-wire)	PC Comm. Out	PC RS485 communication	1	GND (Blue)
				2	B (White)
				3	A (Yellow)
J3	N/A		Future application		
J4	Input (2x2-wire)	Ex.I & En.I	Entry and exit gates from side I	1	Either entry I gate wire
				2	Either entry I gate wire
				3	Either exit I gate wire
				4	Either exit I gate wire

Connector	Cable	Connects to		Wires for Afimilk source cables	
		Device	Connection		
<b>J5</b>	Input (2x2-wire)	Ex.II & En.II	Entry and exit gates from side II	1	Either entry II gate wire
				2	Either entry II gate wire
				3	Either exit II gate wire
				4	Either exit II gate wire
<b>J7</b>	Signal (3-wire)	IO or Comm	Future application IO RS485 port	1	GND (Blue)
				2	B (White)
				3	A (Yellow)
<b>J8</b>	Flat cable (10 wire)	Display Panel PCB	J1 in Display PCB	prewired	
<b>J10</b>	Power (2-wire)	24VAC IN	24VAC input cable from Transformer	1	AC~
				2	AC0
<b>ANT1-5</b>	RF Signal (Coax. cable)	Antennas outputs	antennas	1	Shield
				2	Wire

## Connectors and Functions

### Wire the cables in the following order:

1. Connect the **antenna signal cables**, using ferrule type terminators, as follows:
2. Connect the **shield wire** of the antenna's Coax cable to **ANTx Pin 1** (18AWG Ferrule connector).
3. Connect the **signal wire** of the antenna's Coax cable to **ANTx Pin 2** (16AWG Ferrule connector).

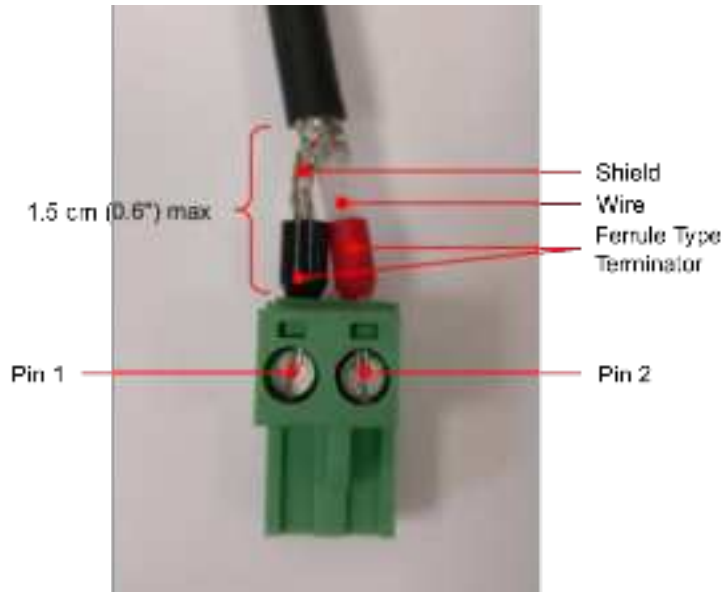

Figure 8 – Antenna Signal Cables Wiring

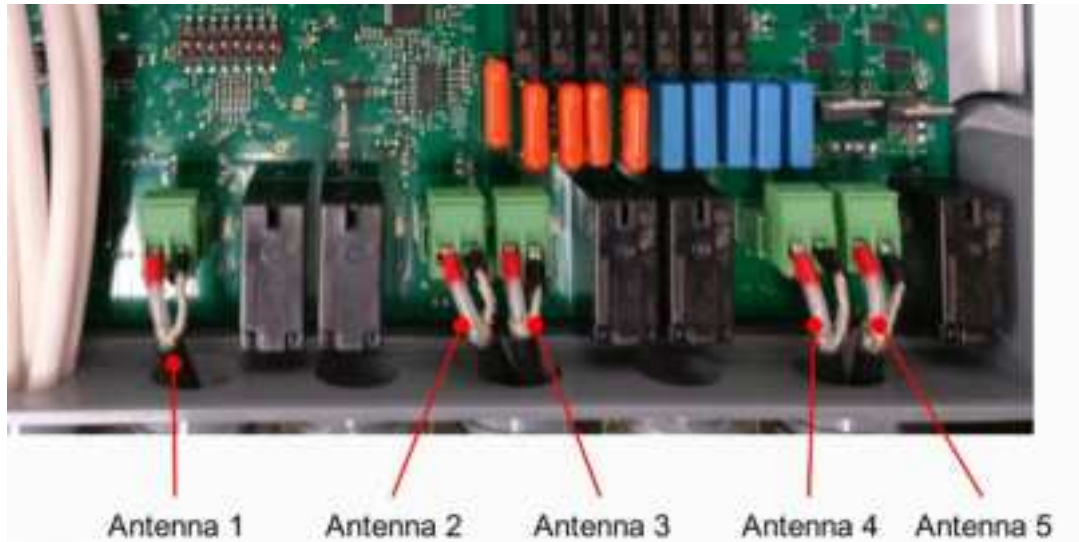

Figure 9 – Antenna Signal Cable Connectivity

- **Note:** If the cable is cut to size, make sure to use ferrule type terminators as described above. Do not expose the wires more than 1.5 cm (0.6 inches) Figure 8. Bend the ferrule type terminators slightly towards the cable outlet to avoid exposed wires coming into contact with the Display panel's PCB when the lid is closed. Make sure to leave as little cable slack as possible (see Figure 9).

**⚠ Caution:** When connecting the wires of the antenna signal cable to the plug, make sure the screws are fastened tightly and no wires from the shield are loose. Loose connections can result in a shortage and Controller malfunction.

4. Connect antenna cable connectors to the PCB.
5. Repeat steps 1 to 4 for the number of antennas used (see Figure 10).



**Figure 10 – AfiPass II Controller with 5 Antennas Connected**

6. Connect the communication cables: Connect a standard RS-485 communication cable (input from PC or previous device) to the **PC COMM In** connector (J1) on the left edge of the AfiPass II PCB.
7. Connect a standard RS-485 communication cable (output to next device) to the **PC COMM Out** connector (J2) on the left edge of the AfiPass II PCB.

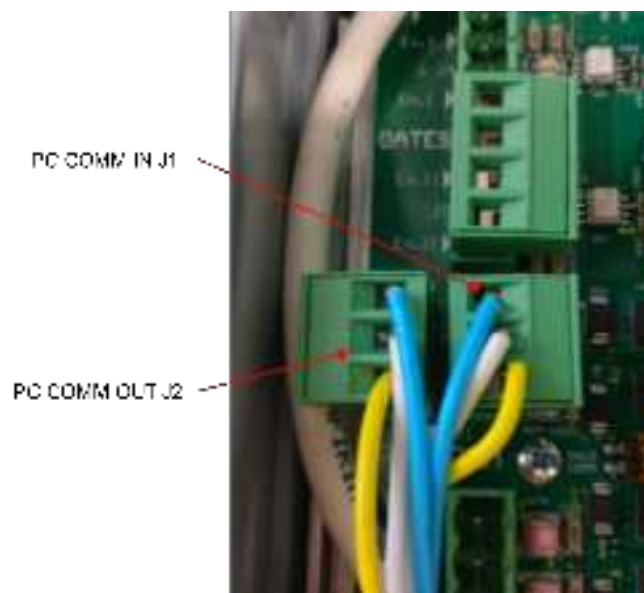

**Figure 11 – Communication Cables**

8. For the last device on the communication line, set the termination DIP switch **SW2 pin 1** to ON. This will enable the 120Ω termination resistor required for the RS485 communication line.



Figure 12 – Communication Cables

9. Connect to PC (see Figure 13): Connect the RS-485 communication cable coming from the AfiPass II devices to the **AfiCom USB4 Connection Box's** J5 connector.
10. Connect the C1 plug communication cable from the **AfiCom USB4 Connection Box** to the **USB4 adaptor**.

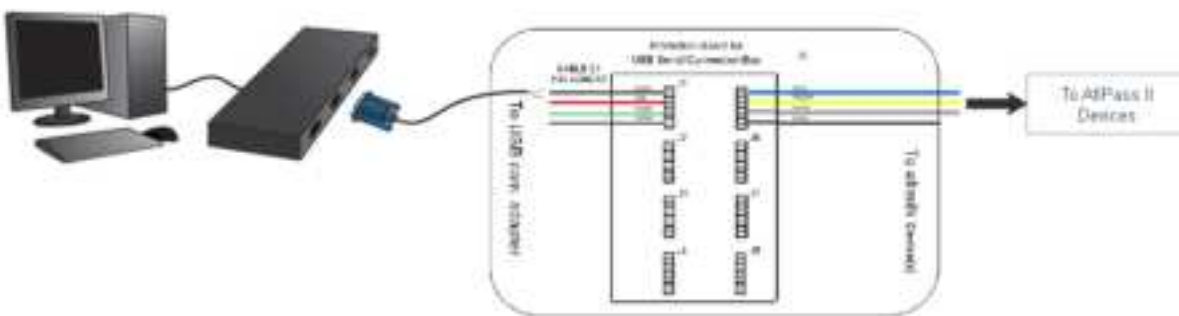

Figure 13 - Connection to PC

11. Connect the gate switches to the Main Display Device (device #1):

Connect gate switches to J4 and J5 in the AfiPass II (see AfiPass II Control PCB Connections above). These switches must supply a dry contact signal and should be connected as illustrated below, and as printed on the PCB, next to J4 and J5.

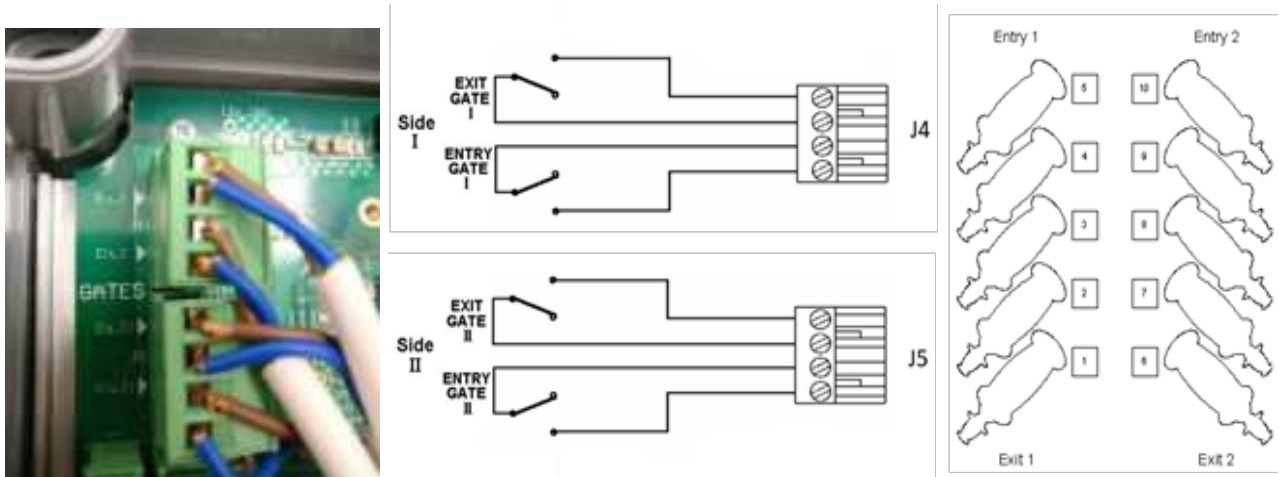

Figure 14 – Gates Indicators Cables Connection

12. Connect the power supply to the AfiPass II Controller.

The AfiPass II Controller is powered by a 20.4-27.6 VAC power supply. The power line from the transformer is connected to connector **J10**. Run the wire alongside the box's edge as shown below. Make sure the wire does not touch any components on the Controller's PCB.

- **Note: An internal fuse on the PCB protects the circuit. In case of overload, the fuse temporarily blocks power supply to the board. After the short circuit has been repaired, the power supply is reconnected.**
- ⚠ **Caution: Do not connect the AfiPass II Controller to the same power supply that is used for the Milk Meters.**
- ⚠ **Caution: Do not connect the "ground" wire of the AfiPass II Controller to the main power supply outlet "ground".**

**Ensure that the point to which this wire is connected is well grounded, whether it is the metallic frame of the building, or a special grounding electrode mounted in the ground.**



Figure 15 – Wiring Example of the Main Display Device

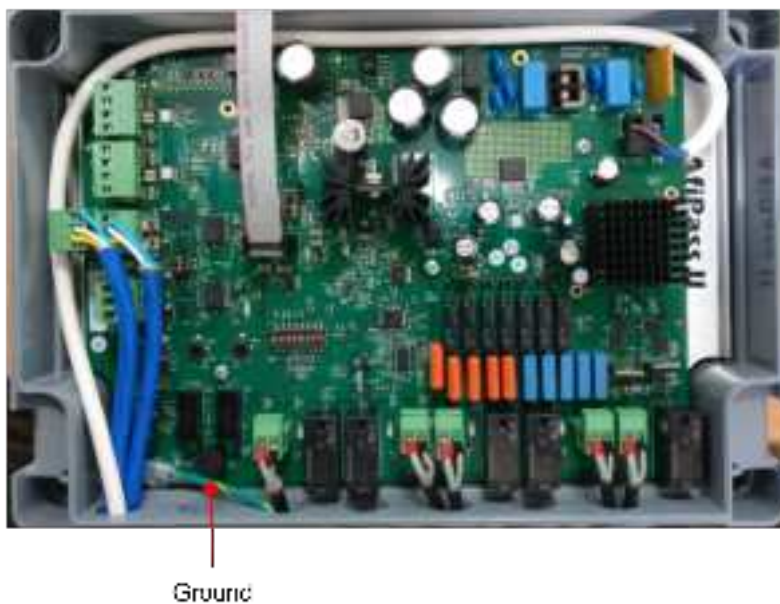

Figure 16 – Wiring Example with Grounding

## 7.5 Finalizing the Wiring Connections

To finalize the wiring connection after connecting the wires to the connectors:

1. Adjust the cables to an appropriate length inside the box.
2. Tighten the grommet nuts.
3. Make sure the box closes properly.

## 8 Setting AfiPass II Addresses and Calibrating Antennas

Access Test Mode to assign each device's address, and then to calibrate the antennas individually. While in test mode, adjust the required ID range (transmit power level) to ensure accurate tag detection.

The above Test Mode operations are undertaken using the AfiPass II Technician Tool and SW1 DIP Switch (see APPENDIX 2 – DIP Switch).

The Technician's tool contains two toggle switches (TS1 & TS2) that set the operation mode, and two push buttons (PB1 & PB2) that control the operation and set the desired parameters.



- While the device is in Test Mode, communication with the PC is disabled and the COMM FAULT LED starts flashing after 30 seconds. This does not interfere with the configuration operations.

The procedure's workflow is as follows:

1. Open Test Mode.
2. Assign Addresses to each device.
3. Calibrate each antenna.
4. Set the antenna's transmission power to the required ID range.
5. Exit test mode.

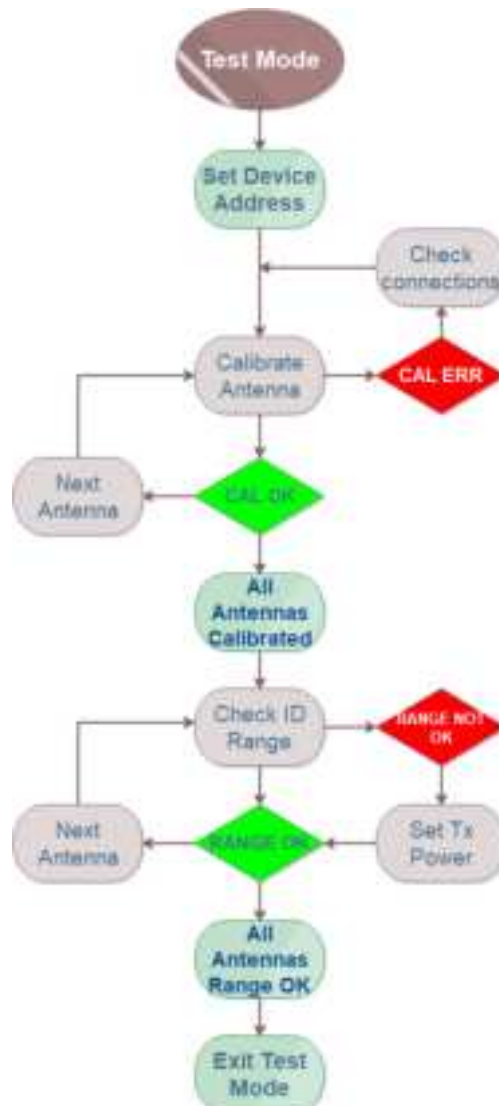

## 8.1 Opening Test Mode

Set the AfiPass II Controller Test Mode Operation as follows:

### To open Test Mode:

1. Disconnect the device from the power supply (J10).
2. On the AfiPass II PC Board turn ON the following SW1 DIP Switches:
  - a. SW1.1 (Buzzer),
  - b. SW1.2 (Test Mode).
3. Turn OFF the following SW1 DIP Switches:
  - a. SW1.3,
  - b. SW1.4
  - c. SW 1.5.
4. Connect the power supply (J10).

Indication: The display shows 'Test M'.



5. Connect the **AfiPass II Technician Tool** pin connectors instead of the gates' connectors (see Figure 17):
  - a. The connector with the yellow, black, white, and blue wires connects to **J4**.
  - b. The connector with the orange, brown, red, and green wires connects to **J5**.



Figure 17 – Technician Tool Connections in AfiPass II Controller

6. Reconnect the power (by connecting the power cable to the J10 connector).

## 8.2 Setting Device Addresses

Each AfiPass II Controller must be set with its own address number.

- **Note: The AfiPass II Controller Main Display Device must be set as Address 1 to display currently active antenna for the whole parlor, and the status of entry and exit gates.**
- **When configuring the Main Display Device, disconnect the gate cables. Once your activity is complete, reconnect the gate cables.**

**To set the device address:**

1. On the Technician Tool, turn OFF TS1 and TS2.
2. On the SW1 Config. Dip Switch, turn ON SW1.3 (address switch).

Indication: The display shows 'ADR T'.



3. Click PB1 or PB2.

Indication: The display shows the current address of the device 'ADR XX'.



4. Press **PB1** and **PB2** simultaneously.

Indication: Sound is emitted for 4 seconds. The display flashes the current address of the device '**ADR XX**'.

5. Change the address by pressing **PB1** (increment by 1) or **PB2** (decrement by 1).

- **Note: A long press on PB1 or PB2 will increase/decrease the value by 10.**

6. Press and hold **PB1** and **PB2** simultaneously for 3 seconds to set the address.

Indication: Sound is emitted for 4 seconds. The display flashes the current address of the device '**ADR XX**'.

### 8.3 Calibrating the Antennas

Calibrate each antenna for optimal resonance.

#### To calibrate the antennas:

1. Set the technician's tool to CAL Mode. On the Technician toolbox:
  - a. Turn ON TS1.
  - b. Turn OFF TS2.

Indication: The display shows 'CAL T'.



2. Set the antenna number:
  - Press PB1 to increase in increment by 1.
  - Press PB2 to decrease in increments of 1.

Indication: The display alternates between the antenna number and the calibration value (calibration values range from 1-127).



3. Calibrate the selected antenna: Press PB1 and PB2 simultaneously. Hold these down for 3 seconds. The calibration process takes about 30 seconds.

Indication: The display shows 'CL\*\*XX'



Indication: Once the Calibration process is complete, if successful, the display shows 'CL OK' and a sound is emitted for 4 seconds.

The selected antenna's calibration value is now saved in the device memory and will remain unless the process is repeated and the value changes.



If unsuccessful, an error message is displayed. In this case, make sure the antenna is connected properly, the connector is in place, and no loose wires from the shield wire of the coax cable are shorted.

4. Repeat the calibration process for all the antennas.

## 8.4 Setting Transmission Power and Reception Range

Once the calibration process is complete, the antenna reception range may need to be adjusted to prevent ID overlaps between stalls.

The AfiPass II Controller allows 17 transmission power levels, -8 to 8 with the default at 0, to increase or decrease the ID range.

While in Antenna Power Mode, once the desired antenna is selected, the device will transmit continuously to enable you to set the power level for the desired ID range. The test is done using the Passive Identification tag. The RX LED and buzzer (if enabled) will indicate proper reception at the distance of the tag from the antenna.

### To change the transmission power:

1. Set the technician's tool to **PWR Mode**:
  - a. Turn OFF **TS1**.
  - b. Turn ON **TS2**.

Indication: The displays shows 'PWR T'.



2. Set the antenna number:

- Press PB1 to increase in increment by 1.
- Press PB2 to decrease in increments of 1.

Indication: The display alternates between the antenna number and the Tx power level (-8 to 8).

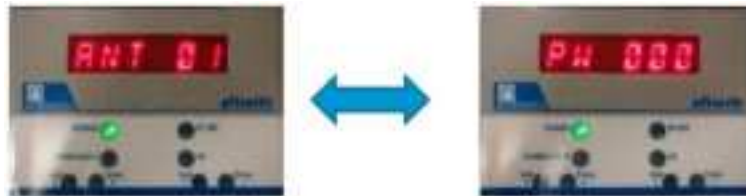

3. Enable continuous transmission: Press **PB1** and **PB2** simultaneously. Hold them down for 3 seconds. The selected antenna starts transmitting.

Indication: Sound is emitted for 4 seconds. The display shows 'PWR 00X' as shown above (where '00X' is the current power level)

4. Hold a passive ID tag in front of the antenna in the location and distance where the ID is required and use **PB1** and **PB2** to adjust the Tx power level (ID range). Make sure to check the peripheral range of the ID to avoid overlaps between the stalls.

Indication: The RX LED turns on and sound is emitted (if the buzzer is enabled) while the tag is within the ID range of the antenna.

- **Note: The AfiPass II Controller has a built-in safety mechanism that limits the transmission power, so that it doesn't exceed the permitted power levels. If the power level is too high the display will show error message 'ERR 06' and the power level must be decreased.**

5. Once the required range has been achieved, press and hold **PB1** and **PB2** simultaneously for 3 seconds to set the power level.

Indication: Sound is emitted for 4 seconds and the display alternates between the antenna number and the selected power level (as shown in section 2).

6. Repeat the power level setting process for all the antennas.

## 8.5 Testing ID Range and Troubleshooting

**Test Mode** also allow a dedicated continuous transmission mode, similar to the transmission power setting mode, for testing and troubleshooting. The test is done using the Passive Identification tag. The RX LED and buzzer (if enabled) will indicate proper reception at the distance of the tag from the antenna.

### To check the reception range:

1. Set the technician's tool to **ANT Mode**: Turn ON **TS1** and **TS2**.

Indication: the displays shows 'ANT T'.



2. Set the antenna number:
  - Press PB1 to increase in increment by 1.
  - Press PB2 to decrease in increments of 1.

Indication: The display shows the selected antenna number 'ANT XX' and the antenna starts transmitting immediately.



3. Check the ID range using a passive ID tag.

Indication: The RX LED turns on and a sound is emitted (if the buzzer is enabled) while the tag is within the ID range of the antenna.

## 8.6 Returning to Work Mode

Once the addressing, calibration and transmission processes are complete, the device must be returned to work mode.

### To set the device in work mode:

1. Disconnect the device from the power supply (J10).
2. Turn OFF **all** DIP Switch **SW1** switches.
3. Disconnect the technician's tool from the gate connectors.
4. On Device #1, reconnect the gates.
5. Connect the devices to the power supply (**J10**).
6. Ensure the device turns on in working mode, with the appropriate indication: The display alternates between the device address and FW version and all LEDs blink.

● **Note: Reset the device after each Entry/Exit from Test Mode.**

**Reset the device by disconnecting the device's power for 3-4 seconds (disconnect and reconnect the power cable from J10 connector).**

## 9 Configuring the System

Once the AfiPass II devices have been correctly installed, the AfiPass II system is configured in AfiControl – Technician View.

The AfiPass II system is configured in the AfiControl Technician View.

**To configure AfiPass II:**

1. In the Control Tabs, click **Settings**, and then click **Configurator**.



2. In the Configurator screen that opens, add a site:
3. Click .
4. Click **Parlors**, and then select the type of parlor layout.



5. In the Parlor dialog box that opens, open the Reader Type drop-down list, and then select **AfiPass2**.
6. Click **Add**.



The site is added in the Configurator.



## 10 Using AfiPass - First Time

The Display panel of the AfiPass II controller provides information about the device and its current status (see Table 11).



**Table 11 - Display Panel's LED Functionality**

Description	Functionality	Color
LED Display	Indicates device address, FW version, current transmitting antenna, error messages and information regarding device configuration while in Test Mode.	
Power	Always ON when device is powered.	GREEN
Comm Fault	Flashes when communication with the PC is lost for more than 30 seconds.	RED
Rx	Lights up for 1 second upon valid tag ID reception.	GREEN

Description	Functionality	Color
RF INT	<p>Indicates the presence of RF interference (noise) in the vicinity of the currently transmitting antenna at the frequency range of the device. The LED indication has 4 levels of interference detection:</p> <ul style="list-style-type: none"> <li>Level 1 (lowest) – Blinks every 3 seconds.</li> <li>Level 2 – Blinks every 2 seconds.</li> <li>Level 3 – Blinks every 1 seconds.</li> <li>Level 4 (highest) – continuously ON.</li> </ul> <p><b>Note:</b> This LED will also light up upon tag ID reception since the tag's transmission is also perceived as RF "noise". Refer to this LED indication as interference only while the controller is transmitting and there is no tag in the antenna's range (while in work or test mode)</p>	RED
Exit/Entry I & II	<p>Lights up when the corresponding entry/exit gate is closed.</p> <p><b>Entry I &amp; Exit I</b> – correspond to the gates on the side with the lower Milk Meter numbers.</p> <p><b>Entry II &amp; Exit II</b> – correspond to the gates on the side with the higher Milk Meter numbers.</p>	RED

## 10.1 Gates Indicators

Confirm the Gate are correctly wired and working as follows:

- Gate closed** = Gate LED is ON.
- Gate open** = Gate LED is OFF.

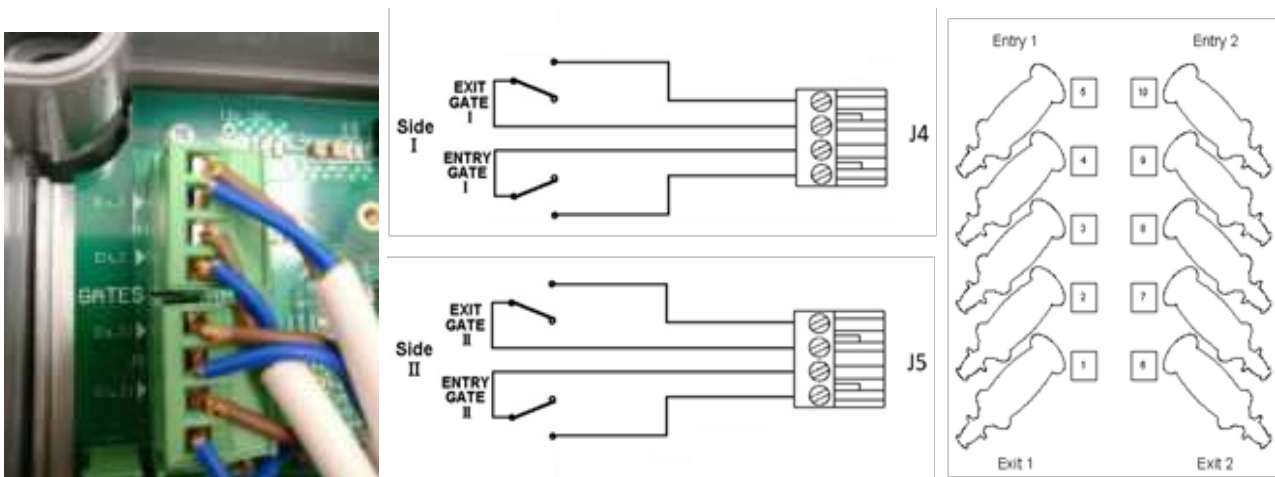

Figure 18 – Gates Indicators Cables Connection

## 11 Identifying Faults and Troubleshooting

Indication	Probable Cause	Suggested Solution
AfiPass II COMM FAULT LED blinks red & AfiControl displays communication fault with the devices.	Broken communication between AfiPass II and PC.	<p>Verify the communication cables between the AfiPass II &amp; PC are intact.</p> <p>Make sure the AfiPass II communication connectivity is intact, properly connected and wired according to spec.</p> <p>Make sure the AfiPass II is not in Test Mode.</p>
No LED and/or display indication in the AfiPass II.	<p>Display PCB flat cable is disconnected.</p> <p>AfiPass is not working at all.</p>	<p>Verify that the flat cable leading from the control PCB to the display PCB is intact and properly connected.</p> <p>Verify that the 24VAC power cable is connected properly to the AfiPass II.</p> <p>Verify that the 24VAC power supply is turned ON and supplies 24VAC.</p> <p>If power is OK, replace controller.</p>
ID tag not identified/insufficient ID range	Antenna not calibrated/low transmission power.	Initiate antenna calibration process and adjust Tx power level.
Display shows 'ERR 06' and/or 'ERR 08'	<p>Antenna is shorted or disconnected.</p> <p>Antenna has not been calibrated to resonance.</p>	<p>Verify the antenna cable is intact, properly connected, and no loose wires from the shield wire of the coax cable are shorted.</p> <p>Initiate antenna calibration process and adjust Tx power level.</p> <p>If error persists: Isolate the problematic component (i.e. antenna output or the antenna itself) by crossing the malfunctioning antenna with a functioning antenna connected to same controller and initiating antenna calibration process on both outputs. If the malfunctioning antenna still shows an error replace antenna. Otherwise replace controller.</p>
Display shows 'ERR 05'	<p>Antenna Tx power level is too high.</p> <p>Transmission circuitry overcurrent/overtemperature.</p>	<p>Initiate antenna calibration process and adjust Tx power level.</p> <p>If error persists, replace controller.</p>

## APPENDIX 1

Cable ducting in vertical lift parlors must be robust to withstand contact with cows.

Many products are available that provide a solution to this. We recommend ducting within the stall work itself. However, thought must be given to future maintenance and the option for economical rewiring.

### Cable Chain for Vertical Lift Chest Bar Stall Work

CABLE GUIDE FOR PASSIVE ANTENNA CABLE (Bend radius $\geq 30\text{mm}$ )		
Afimilk Part Number	MCMMASTER CARR	IGUS
Cable Carrier	4409T33	E2-1540038-6MC
Cable Carrier Mounting End (Pair)	4556T43	E2-150-40-12PZ

### Cable Chain Length Calculations

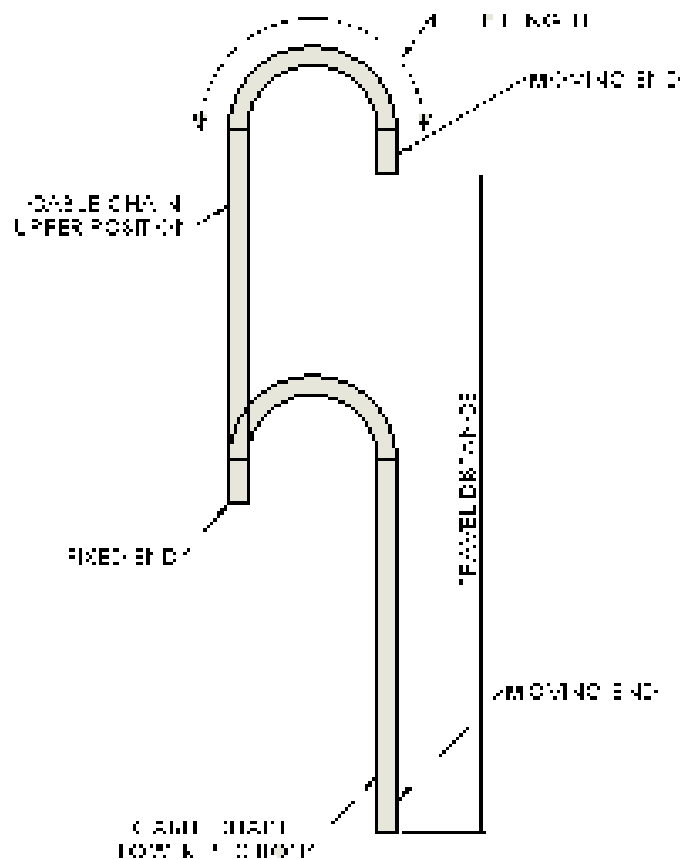

$$\text{Cable carrier length} = \text{Loop length} + \frac{\text{travel length}}{2}$$

The values of the loop length are available from the cable carrier supplier websites.

- Note: To extend its viability, Afimilk recommends using supports on both sides of the cable carrier, and to follow the advice of the cable carrier manufacturers.



**Both sides supported. Recommended for long life of cables**



**Single side supported**

## APPENDIX 2 – DIP Switch

The AfiPass II Controller contains the following DIP switches (see Figure 19 and Table 12).

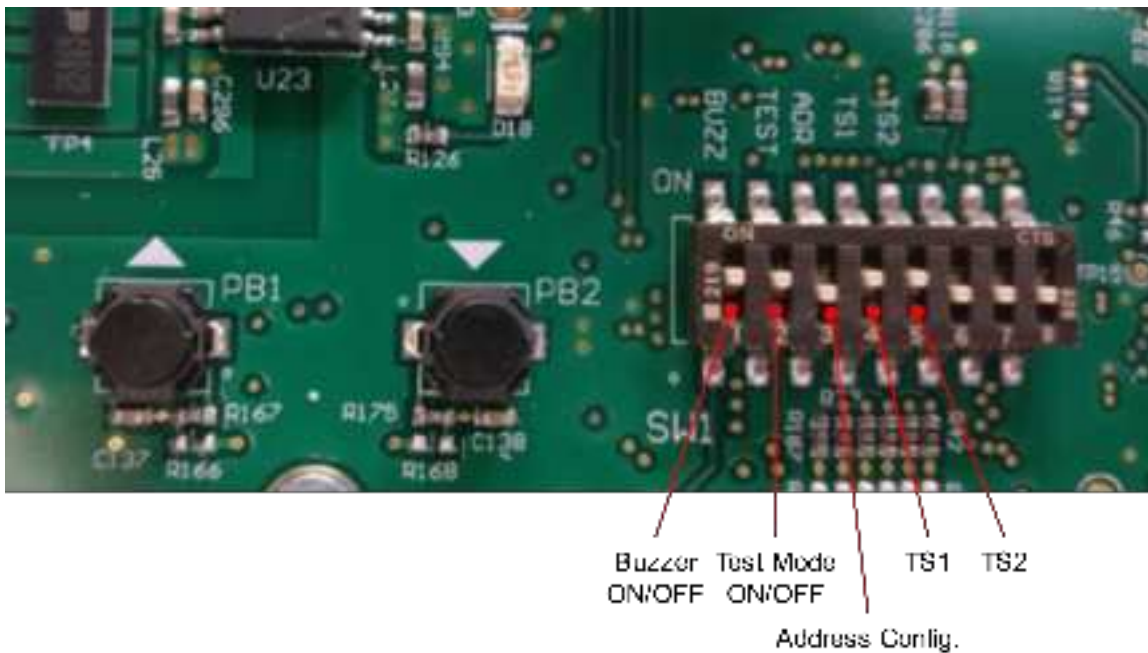

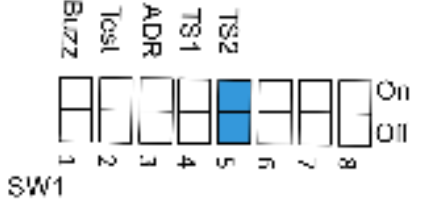

Figure 19 – DIP Switches

Table 12 – Box DIP Switch SW1 Specifications

Switch Entry	Details	Picture
SW1.1	On - turns buzzer on. Off – turns buzzer off.	<p>Diagram of SW1 switch with 8 positions. Position 1 (BUZZER) is turned ON (blue). Positions 2 (Tcs1), 3 (ADR), 4 (TS1), 5 (TS2), 6, 7, and 8 are turned OFF (white).</p>
SW 1.2	On – turns on Test Mode. Off – turns on Operational Mode.	<p>Diagram of SW1 switch with 8 positions. Position 2 (Tcs1) is turned ON (blue). Positions 1 (BUZZER), 3 (ADR), 4 (TS1), 5 (TS2), 6, 7, and 8 are turned OFF (white).</p>
SW 1.3	On – sets the device to Address Configuration Mode, while in Test Mode.	<p>Diagram of SW1 switch with 8 positions. Position 3 (ADR) is turned ON (blue). Positions 1 (BUZZER), 2 (Tcs1), 4 (TS1), 5 (TS2), 6, 7, and 8 are turned OFF (white).</p>

Switch Entry	Details	Picture
SW 1.4	Matches TS 1 functionality in the technician tool.	
SW 1.5	Matches TS 2 functionality in the technician tool.	
SW 1.6 –1.8	Reserved for future use.	

## **Contacting Technical Support, Help Desk**

Afimilk technical support contact information:

**Email:** support@afimilk.co.il

**Tel:** +972-4-675-4824

## **Legal Notice**

### **Copyright**

Copyright © 2020 Afimilk Ltd., All Rights Reserved

### **Disclaimer**

This document contains proprietary information of Afimilk Ltd. and may not be reproduced in any form without the prior written consent of Afimilk Ltd.

No part of this document may be reproduced, translated, stored in a retrieval system or transmitted in any form and by any means, electronic, mechanical, photographic, photocopying, recording, or otherwise, without the prior written permission of Afimilk Ltd.

Information provided in this document is subject to change without notice and does not represent a commitment on the part of Afimilk Ltd.

All products and company names are trademarks or registered trademarks of their respective holders.

### **Software License Terms**

The software and the system design are the property of Afimilk Ltd.

It is supplied to the user to be used solely for its stated purposes. It is strictly forbidden to make copies of the software or transfer it in any way, for any purpose, to any third party.

In addition to application software specifically developed by Afimilk Ltd., the system makes use of certain third-party utilities and system software. These are licensed for a single user. They must not be copied in any way, for any purpose, by the user, its employees, or anybody else.

The license to use the software is granted to the user only for the specific system it is installed on by Afimilk Ltd., or its authorized distributors and representatives.

The purchaser shall not modify the software in any way.

It is strictly forbidden to use this product for any purpose other than originally designated for or stipulated by Afimilk Ltd.

## Certification

<h1>Afimilk®</h1>		<h1>AfiPass II</h1>	
<h2>Livestock Passive ID System Controller</h2>			
<p>Contrôleur de système d'identification passive des vaches Контроллер пассивного идентификатора домашнего скота</p>			
<p>Power/Мощность: 22-28VAC</p>		<p>50-60Hz 1.5 Amax</p>	
<p>This device complies with part 15 of FCC Rules. Operation is subject to the following two conditions: (1) This device may not cause harmful interference, and (2) this device must accept any interference received, including interference that may cause undesired operation. <b>FCC ID: JER 4095910</b></p>			
		<p>IC: 21531-5910</p>	
		<p>IPX5</p>	
		<p>Complies with UL 62368-01 CSA C22.62368-01 Type 2a enclosure</p>	
			
		<p>9540927 rev. 1.0</p>	

