

Fisher™ DFA Variable Geometry Desuperheater

Contents

Introduction	1
Scope of Manual	1
Description	1
Educational Services	3
Principle of Operation	3
Installation	4
Nozzle Maintenance and Replacement	6
DFA Desuperheater Variable Geometry Nozzles ...	7
DFA Installation	9
Troubleshooting	9
DFA Parts Ordering	10
Parts List	11

Figure 1. Fisher DFA Variable Geometry Desuperheater

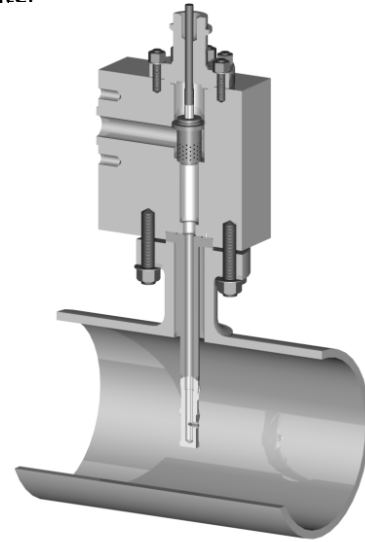

X0838

Introduction

Scope of Manual

This instruction manual includes installation, maintenance, and operation information for the DFA variable orifice desuperheater. Refer to separate instruction manuals for information on the actuator and accessories.

Do not install, operate, or maintain a DFA desuperheater without being fully trained and qualified in valve, actuator, and accessory installation, operation, and maintenance. To avoid personal injury or property damage, it is important to carefully read, understand, and follow all the contents of this manual, including all safety cautions and warnings. If you have any questions about these instructions, contact your [Emerson sales office](#) or Local Business Partner before proceeding.

Description

The Fisher DFA desuperheater flexible architecture (figure 1) incorporates both a water control element and a variable-geometry mechanically atomized, self-contained desuperheater for moderate to high flow variation. It is installed through a flanged connection on the side of an NPS 8 or larger pipeline.

The desuperheater design incorporates an integral thermal liner inside the desuperheater body pipe. This minimizes the potential for thermal shock when cool water is introduced to the unit which has been heated to the operating steam temperature.

The nozzle mount for the DFA is engineered to minimize the potential for excitation due to vortex shedding and flow induced vibration. The DFA desuperheater is installed through a flanged connection on a DN 200 (NPS 8) or larger pipeline. Maximum nozzle C_v is 15.0.

Table 1. Specifications

<p>Available Configurations⁽¹⁾ and Valve Sizes</p> <p>■ DFA valve body style: Angle</p> <p>Common Characteristics: Designed according to ASME B16.34 Valve-Flanges, Threaded and Welding End</p> <p>End Connections Styles⁽¹⁾</p> <p>See tables 2 and 3</p> <p>Maximum Inlet Pressure and Temperature^(1,2)</p> <p>Flanged, Socketwelding, or Buttwelding: Consistent with CL150, 300, 600, 900, 1500, and 2500 according to ASME B16.34, unless limited by maximum pressure drop or material temperature capabilities</p> <p>Maximum Pressure Drop⁽¹⁾</p> <p>Valve with Cavitrol™ III Cage: 149 bar (2160 psi) for two-stage and 207 bar (3000 psi) for three-stage cage. Consult Fisher Bulletin 80.2:030, Cavitrol III One-, Two-, and Three-Stage trims, for more information</p> <p>Anti-cavitation MicroFlat: <51.7 bard (<750 psid)</p> <p>Inherent Rangeability</p> <p>Up to 50:1. The ratio of maximum to minimum controllable C_v is dependent upon the available water pressure differential</p> <p>Spray Water Pressure Required⁽³⁾</p> <p>6.9 bar (100 psi) above steam pressure</p>	<p>Shutoff Classifications per ANSI/FCI 70-2 and IEC 60534-4</p> <p>Class V only</p> <p>Material Temperature Capabilities⁽¹⁾</p> <p>Up to 593°C (1100°F) depending on construction</p> <p>Flow Characteristics⁽⁴⁾</p> <p>Standard Cages: ■ Linear, ■ equal percentage, ■ modified equal percentage⁽⁵⁾</p> <p>Cavitrol III: Linear</p> <p>Micro-Flat (with or without liner): Linear</p> <p>Flow Direction</p> <p>All: Flow down</p> <p>Bonnet Style and Mounting⁽¹⁾</p> <p>Standard Bonnet</p> <p>Yoke Temperature Limit: Standard bonnet with cast iron yoke is limited to 537°C (1000°F)</p> <p>Packing Arrangements</p> <p>■ Single, ■ Double, and ■ Leakoff standard graphite packing, or optional ■ ENVIRO-SEAL™ and ■ HIGH-SEAL packing systems. See bulletin 59.1:061, ENVIRO-SEAL and HIGH-SEAL Packing System for Sliding-Stem Valves</p> <p>Approximate Weight</p> <p>See table 12</p>
--	---

1. Do not exceed the pressure or temperature limits in this bulletin, nor any applicable code or standard limitations.
 2. EN (or other valve body material) ratings and end connections can usually be supplied; consult your [Emerson sales office](#) or Local Business Partner.
 3. A function of required turndown and equipment selection.
 4. Special characterized cages are available. Contact your Emerson sales office or Local Business Partner.
 5. Modified equal percentage characteristic is equal percentage for the first 75% of travel, then opens quickly for additional capacity.

The DFA features:

1. Fine atomization over a wide range of operating conditions helping to assure rapid and complete vaporization of injected water.
2. Available with a wide range of standard and anti-cavitation trim styles.
3. Design minimizes affects of thermal cycling.
4. High turndown capability.
5. Flexible architecture with multiple valve trim combinations and face-to-face dimensions available.

Educational Services

For information on available courses for the Fisher DFA Desuperheater, as well as a variety of other products, contact:

Emerson Automation Solutions
 Educational Services - Registration
 Phone: 1-641-754-3771 or 1-800-338-8158
 E-mail: education@emerson.com
 emerson.com/fishervalvetraining

Principle of Operation

The DFA desuperheater reduces steam temperatures through the introduction of cooling water directly into the hot steam flow stream. By regulating the quantity of water that is injected, accurate downstream steam temperature can be both controlled and maintained.

The rate of vaporization, and/or cooling, is a function of droplet size, distribution, mass flow, and temperature. Steam velocity is critical and should be maintained at 6.1 to 9.1 meters per second (20 to 30 feet per second) as the minimum. Actual minimum steam velocity requirements will vary by application. As steam velocity increases, a longer distance is required to achieve homogeneous mixing and to complete vaporization.

In DFA desuperheater nozzle styles, the spraywater quantity is controlled by internal control valve which responds to signals received from the temperature control system. The water enters the main tube of the desuperheater, passes through the spray nozzle, and discharges into the steam line as a fine, atomized spray (see figure 4).

Each particular nozzle, or set of nozzles, in the sprayhead is tailored to meet a specific set of operating conditions. The nozzle design optimizes the spraywater droplet size promoting rapid atomization and complete vaporization of water in the steam flow stream to obtain precise temperature control. The DFA desuperheater uses a variable geometry AF nozzle. In the AF nozzle design (see figure 4), water enters the swirl chamber via compound angled orifices, thus creating a rotational flow stream. This flow stream is further accelerated as it is forced up and out through the spray annulus. The cone-shaped plug varies the geometry of the spray annulus using a force balance principle between water pressure and the preload exerted by a helical spring. This variable geometry design sprays a thin hollow cone over a wide range of flow rates, resulting in excellent temperature control over a wide range of operating conditions.

Figure 2. AF Nozzle Cross Section

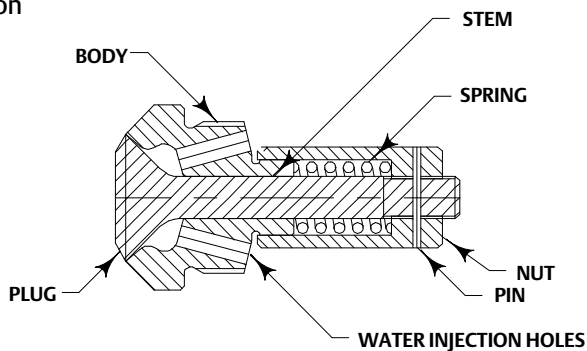

A7191

Installation

⚠ WARNING

Always wear protective gloves, clothing, and eyewear when performing any installation operations to avoid personal injury.

Personal injury or equipment damage caused by sudden release of pressure may result if the desuperheater is installed where service conditions could exceed the limits of the pressure class noted on the nameplate. To avoid such injury or damage, provide a relief valve for over pressure protection as required by government or accepted industry codes and good engineering practices.

Check with your process or safety engineer for any additional measures that must be taken to protect against process media.

If installing into an existing application, also refer to the WARNING at the beginning of the Maintenance section in this instruction manual.

Table 2. Desuperheater Connection Size

Design	Steam Line Size, NPS	Steam Line Connection	
		Size, NPS	ASME Pressure Rating Raised-Face Flange(1)
DFA	8 - 60	3 or 4	CL150-2500

1. Other standard flanges and connections are also available.

Table 3. Available Valve Connections

Valve Inlet Size, NPS	ASME Pressure Rating Raised-Face Flange(2)	Connection	
		Inlet(1,2,3)	Outlet(1,2)
1, 1-1/2, and 2	CL150-2500	RF, RTJ, BW, and SW	RF

1. End connection style abbreviations: RF-Raised Face, RTJ-Ring Type Joint, BW-Butt weld, SW-Socket Weld.
 2. EN (or other valve body material) ratings and end connections can usually be supplied; consult your [Emerson sales office](#) or Local Business Partner.
 3. Socket weld available on NPS 1, 1-1/2, and 2 only.

Table 4. Fisher DFA Dimensions

DESUPERHEATER BODY FLANGE(1)		E INLET CENTERLINE TO OUTLET FLANGE FACE(2)		F INLET FLANGE FACE TO OUTLET CENTERLINE(2)	
Size, NPS	Pressure Rating	mm	Inches	mm	Inches
3 and 4	CL150-1500	152	6	229	9
	CL2500	178	7	241	9.5

1. The NPS 4 DFA requires a 4.00 inch minimum mounting I.D. Contact your Emerson sales office for NPS 3 DFA minimum mounting I.D.
 2. For different centerline to flange face distances Contact your Emerson Automation Solutions sales office.

Table 5. Fisher DFA Installation Dimensions

DESUPERHEATER BODY FLANGE SIZE, NPS	("D" DIMENSION) PIPE LINE	("B" DIMENSION) INSERTION LENGTH		("T" DIMENSION) T-HEIGHT	
	Size, NPS	mm	Inch	mm	Inch
3 and 4	8	332	13.00	222	8.75
	10	358	14.25	222	8.75
	12	384	15.25	222	8.75
	14	400	15.75	222	8.75
	16	425.4	16.75	222	8.75
	18	451	17.50	216	8.50
	20	477	17.75	222	8.75
	22	502	17.75	222	8.75
	24	527	17.75	222	8.75
	30	600	17.63	219	8.63

Table 6. Fisher DFA Minimum Mounting I.D.

MINIMUM BODY FLANGE SIZE		NOZZLE MODEL	MINIMUM MOUNTING I.D.	
NPS			mm	Inch
3		DFA- A,B,C	66.65	2.624
3		DFA- D, E	73.66	2.9
4		DFA- A through H	101.6	4

⚠ WARNING

When ordered, the desuperheater configuration and construction materials were selected to meet particular pressure, temperature, pressure drop, and fluid conditions. Do not apply any other conditions to the desuperheater without first contacting your [Emerson sales office](#) or Local Business Partner.

1. Mount the DFA desuperheater in a “Tee” piece at the desired location in the pipe, in accordance with standard piping practice. The nozzle should be positioned in the top quadrant of the pipe (see figure 3 for the proper “T” length dimension).
2. Clean and flush out the cooling water line before connecting to the desuperheater. Use only clean sources of cooling water. Use of clean water decreases wear and prevents clogging of the nozzle by solid particles.

⚠ WARNING

Personal injury or property damage could result from clogging of the desuperheater. Installation of a strainer and an isolating valve on the water line between the desuperheater and the water control valve is recommended. Failure to do so may result in clogging of the desuperheater by solid particles, thus hampering temperature control of the steam.

3. A minimum straight run of pipe is required downstream of the desuperheater, before any elbow or reducer, to ensure complete vaporization of cooling water. Consult the desuperheater certified drawing for the required distance of straight pipe.
4. The temperature sensor should be mounted according to the manufacturer's instructions. Typical distance to the sensor is at least 9.1 meters (30 feet) downstream of the desuperheater. This distance changes with higher velocity steam flow, elbows, reducers, and the percentage of spraywater required. Consult the desuperheater certified drawing for this distance.
5. There should be no branching out from or into the steam line to divide the steam flow between the temperature sensor and the desuperheater.
6. A typical installation is illustrated in figure 6. A temperature sensor element (TE) measures changes in temperature and transmits a signal to a remote temperature-indicating controller (TC) or distributed control system (DCS). The output signal from the controller is sent to the positioner on the spraywater control valve. The positioner output signal is piped to the actuator. The actuator strokes the stem/plug of the spraywater control valve, as required, to supply the required cooling water to the desuperheater to maintain temperature setpoint.

Figure 3. Fisher DFA Dimensions (also see tables 4 and 5)

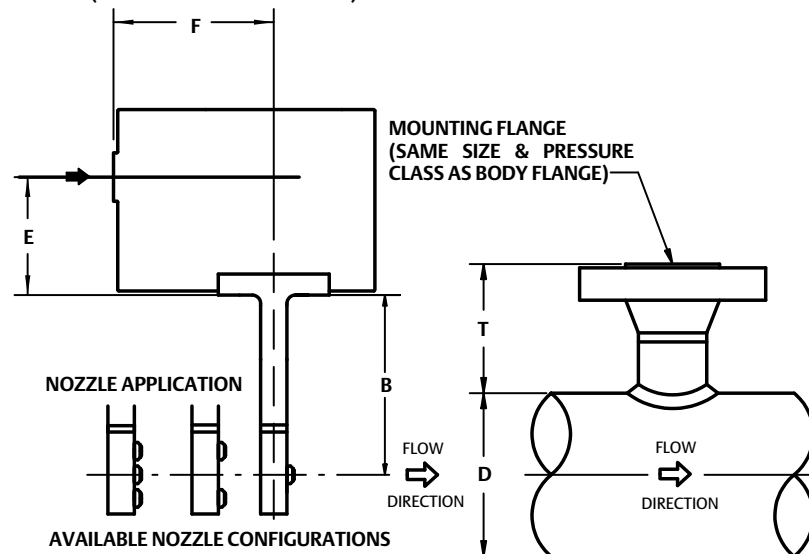

Nozzle Maintenance and Replacement

If it is necessary to remove the DFA desuperheater from service, take note of the following warning.

⚠ WARNING

Avoid personal injury or damage to property from sudden release of pressure or uncontrolled process fluid. Before starting disassembly:

- Always wear protective gloves, clothing, and eyewear when performing any maintenance operations to avoid personal injury.
- Isolate the desuperheater from process pressure. Relieve process pressure on both sides of the desuperheater. Drain the process media from both sides of the desuperheater.
- Use lock-out procedures to be sure that the above measures stay in effect while you work on the equipment.
- Check with your process or safety engineer for any additional measures that must be taken to protect against process media.

When subjected to normal operating conditions, it is possible that wear, blockage, and/or weld fatigue will occur to the desuperheater body or nozzle assembly. During regularly scheduled maintenance, visually inspect the desuperheater welds for cracks and inspect nozzles for wear and blockage. Your local [Emerson sales office](#) or Local Business Partner can help to determine the extent of weld fatigue and the correct course of action. Poor performing nozzles or nozzle failure is typically caused by wear, corrosion, erosion, and/or blockage. The following instruction will help to determine if any of these problems are present and provide a recommended course of action for each.

Note

For optimal performance, nozzles should be inspected every 18-24 months and replaced every 24-36 months.

Figure 4. Fisher AF Nozzle (DFA)

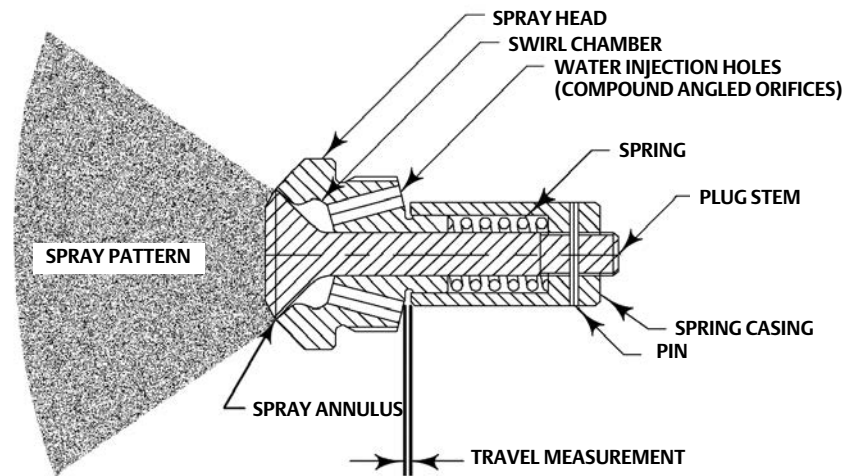

A7191-2D

DFA Desuperheater Variable Geometry Nozzles

1. Inspect the spray annulus surface, the area between the plug stem and spray head, for excessive wear, erosion/corrosion, and/or blockage due to particulate. Wear is defined as any nicks, cuts, or gouges on or immediately around the spray annulus. Erosion/corrosion is defined as any form of rust or erosion of the metal on the plug stem or spray head. Blockages are defined when small particulate becomes trapped between the plug stem and spray head or spring casing and spray head. Replacement of the nozzle is recommended if any of the preceding problems are present.
2. **OPTIONAL:** Figure 4 shows the spray pattern that will need to be present during operation of the AF nozzles. Testing can be performed by attaching the existing or an alternate, similar pressure, water line to the unit. If this spray pattern is not present, replacement is recommended.
3. Grind off the tack welds holding the nozzle in place. Apply a penetrant type thread lubricant and allow to soak prior to unscrewing the nozzle. Using the provided flats on the side of the spray head, unscrew the nozzle.
4. Grind excess tack weld material off of both the nozzle and desuperheater body.
5. In the absence of external forces, the nozzle must be fully closed. If the nozzle is not fully closed, it will need to be replaced.
6. Inspect the water injection holes for reduced or non-circular shape due to erosion. Every hole must be the same size and shape. If any are over-sized or non-circular in shape, the nozzle will need to be replaced.
7. Inspect the interior of the water injection holes for buildup of particulate and/or magnetite. Nozzle replacement will be needed if any buildup is present.

Note

Complete disassembly of the nozzle is strongly discouraged, due to individual spare parts not being available.

8. **OPTIONAL:** To further check the nozzle for buildup of particulate or magnetite, the nozzle can be disassembled. If disassembled, take great care not to damage the sharp edges of the spray annulus on the plug stem and the

sprayhead, as this will greatly affect the spray pattern. Do not compress a removed spring by hand or with a tool, as compression beyond its normal operating range will damage the spring.

To disassemble the nozzle, first remove the pin using a small drill bit as a punch, and unscrew the spring casing from the plug stem. The nozzle can be reassembled by following a reverse order of disassembly, taking care to line the hole in the plug stem up with the hole in the spring casing, then pressing the pin back into place through the two parts.

Table 7. AF Nozzle Specifications

NOZZLE TYPE	PLUG TRAVEL	
	mm	Inches
AF7	0.356	0.014
AF10	0.711	0.028
AF14	0.737	0.029
AF17	0.864	0.034
AF20	0.914	0.036
AF24	1.067	0.042
AF28	1.122	0.048
AF32	1.422	0.056
AF35	1.651	0.065
AF40	1.600	0.063
AF44	1.753	0.069

Figure 5. Spray Nozzle Tack Weld Locations

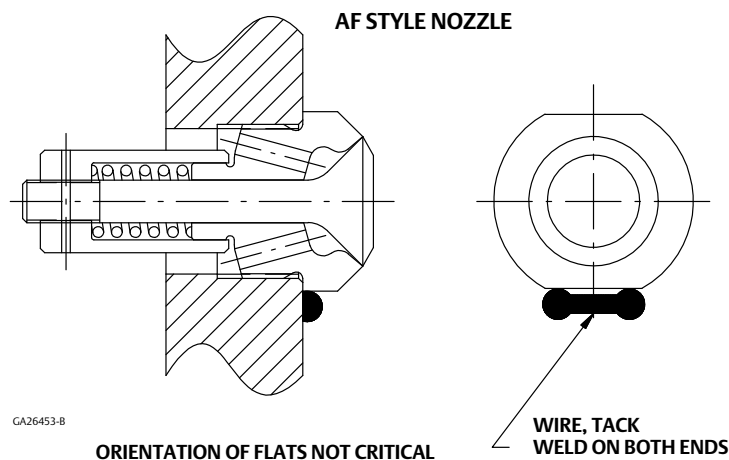

9. The travel can be determined by using a feeler gauge to measure the distance between the nozzle body near the water injection ports to the side of the spring casing as outlined in figure 4. This measurement must match the factory set plug travel for the corresponding nozzle type as shown in table 7.
10. Inspect nozzle threads for damage and clean if needed; if damage is present, nozzle replacement will be necessary.
11. Rinse both the desuperheater body and nozzle to remove particulate.
12. Screw nozzle into the desuperheater body and tighten just until the spray head is flat and tight against the desuperheater body.
13. Tack-weld a small piece of welding wire onto the nozzle mount next to either of the spray head flats to prevent rotation during service (refer to figure 5). Maintain low heat to prevent distortion of the nozzle.
14. Reinstall the desuperheater into the line, using a reverse order of assembly; refer to the installation instructions to complete this step. Make sure the mounting flange gasket (customer supplied) is replaced with a new one.

DFA Installation

Note

Stud(s) and nut(s) should be installed such that the manufacturer's trademark and material grade marking is visible, allowing easy comparison to the materials selected and documented in the Emerson/Fisher serial card provided with this product.

⚠ WARNING

Personal injury or damage to equipment could occur if improper stud and nut materials or parts are used. Do not operate or assemble this product with stud(s) and nut(s) that are not approved by Emerson/Fisher engineering and/or listed on the serial card provided with this product. Use of unapproved materials and parts could lead to stresses exceeding the design or code limits intended for this particular service. Install studs with the material grade and manufacturer's identification mark visible. Contact your [Emerson sales office](#) or Local Business Partner immediately if a discrepancy between actual parts and approved parts is suspected.

1. Place the desuperheater portion of the DFA into the line and align with the pin. Nozzles should face downstream.
2. Insert the gasket into the lower portion of the DFA.
3. Slowly lower the valve body onto the desuperheater portion and ensure that the alignment pin from the lower portion slides into the corresponding hole in the valve body.
4. Completely lower the valve body onto the lower portion and bolt into place using the recommended line gasket bolting torques.

Troubleshooting

Table 8 is intended as a basic first line troubleshooting guide. Contact your local Emerson sales office or Local Business Partner for assistance if you are unable to resolve your field operation problem.

Table 8. Troubleshooting Guide

Problem	Corrective Action
Temperature setpoint is not reached	Check water source availability and pressure
Temperature setpoint is not reached	Check nozzle(s) for plugging
Temperature setpoint is not reached	Make sure that steam saturation pressure is not above setpoint
Temperature setpoint is not reached	Check to ensure full actuator stroke is reached on the spraywater control valve
Temperature setpoint is not reached	Check for proper orientation of nozzle in steam flow
Temperature is below setpoint	Check temperature control loop - reset
Temperature is below setpoint	Check nozzle for fouling/poor spray pattern - clean/replace
Temperature is below setpoint	Check temperature sensor location - relocate per guidelines
Temperature is below setpoint	Check for proper orientation of nozzle in steam flow
Water in steam line	Check that steam traps are functioning properly
Water in steam line when steam line isolated	Check for proper spraywater control valve actuator installation
Water in steam line when steam line isolated	Replace spraywater control valve seat and plug assembly

Figure 6. Typical DFA Installation

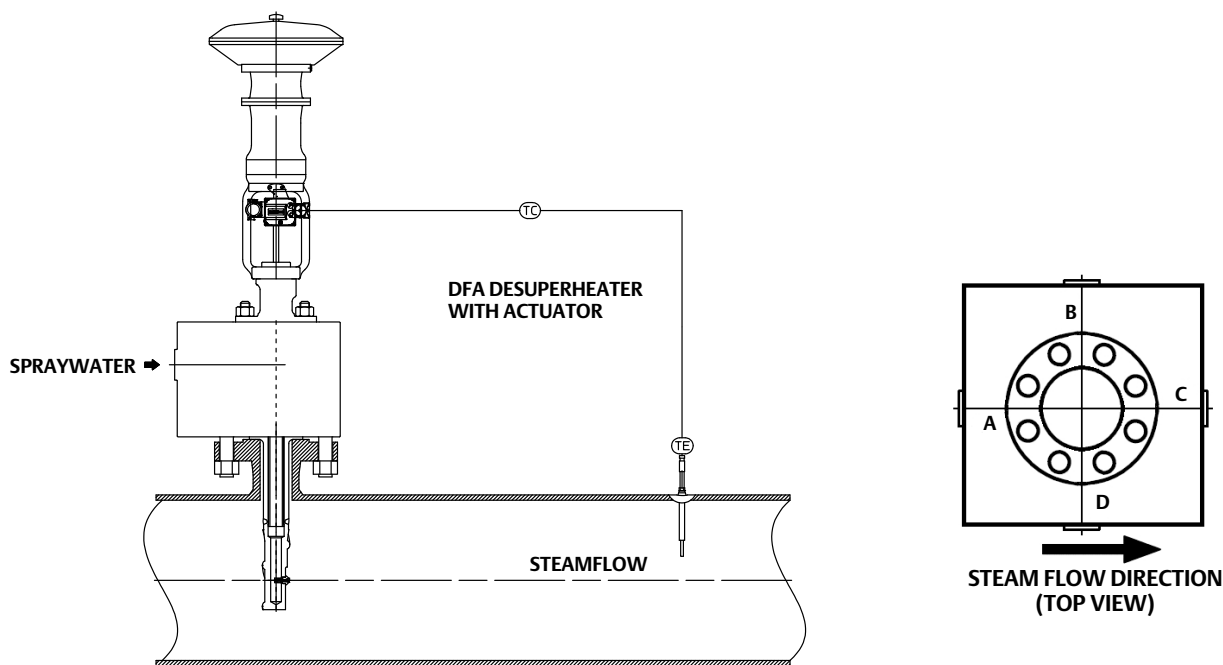

DFA Parts Ordering

Each desuperheater assembly is assigned a serial number which can be found on the mounting flange of the desuperheater. Refer to the serial number when contacting your [Emerson sales office](#) or Local Business Partner for technical assistance. When ordering numbers for each part required, the key numbers on figure 7 can be used to help in part identification.

⚠ WARNING

Use only genuine Fisher replacement parts. Components that are not supplied by Emerson Automation Solutions should not, under any circumstances, be used in any Fisher valve, because they may void your warranty, might adversely affect the performance of the valve, and could cause personal injury and property damage.

Parts List

Key	Description
1	Nozzle Mount
2*	Spray Nozzle
3	Body Flange
4*	Desuperheater Gasket
5	Alignment Pin
6*	Seat Gasket
7*	Seat
8*	Plug Stem Assembly
9*	Cage
10	Valve Body
11*	Bonnet Gasket
12	Bonnet Stud
13	Bonnet Stud Nut
14	Bonnet
15*	Packing Box Ring
16*	Lantern Ring
17*	Packing Rings
18	Packing Follower
19	Packing Flange
20	Packing Flange Nut
21	Packing Flange Stud

Table 9. Desuperheater Gasket

VALVE SIZE, NPS	CLASS	PART NUMBER
3 and 4	CL150 - CL1500	12B4275X042

Table 10. Bonnet Parts

VALVE SIZE, NPS	CLASS	BULLETIN/ INSTRUCTION MANUAL
1, 1-1/2, and 2	CL150 - CL600	EA
1, 1-1/2, and 2	CL900 - CL2500	HPA

Table 11. Trim Parts

VALVE SIZE, NPS	CLASS	BULLETIN/ INSTRUCTION MANUAL
1, 1-1/2, and 2	CL150 - CL600	EA
1, 1-1/2, and 2	CL900 - CL2500	HPA

Table 12. Fisher DFA Weights⁽¹⁾

OUTLET CONNECTION, NPS	INLET CONNECTION, NPS	CLASS	APPROXIMATE WEIGHT	
			kg	lbs
3	1	600	128	283
		1500	183	403
		2500	253	558
	1-1/2	600	137	301
		1500	193	426
		2500	273	602
	2	600	138	304
		1500	206	454
		2500	287	633
4	1	600	179	394
		1500	224	494
		2500	312	688
	1-1/2	600	191	420
		1500	237	522
		2500	337	743
	2	600	193	425
		1500	253	558
		2500	354	781

1. Desuperheater section weighs about 11.4 kg (25 lbs).

Figure 7. DFA Assembly

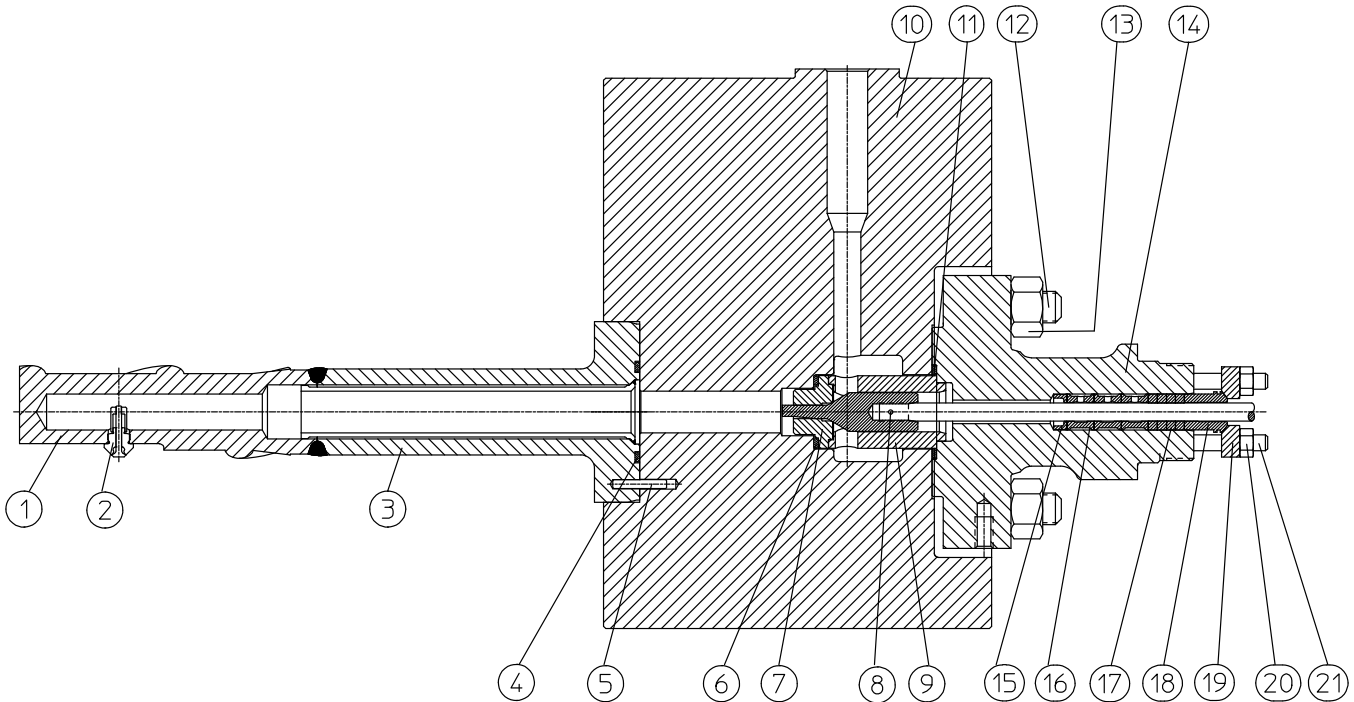

NOTE: IMAGE SHOWN WITH ANTICAV MICROFLAT. OTHER OPTIONS ARE AVAILABLE.

Neither Emerson, Emerson Automation Solutions, nor any of their affiliated entities assumes responsibility for the selection, use or maintenance of any product. Responsibility for proper selection, use, and maintenance of any product remains solely with the purchaser and end user.

Fisher, Cavitrol, and ENVIRO-SEAL are marks owned by one of the companies in the Emerson Automation Solutions business unit of Emerson Electric Co. Emerson Automation Solutions, Emerson, and the Emerson logo are trademarks and service marks of Emerson Electric Co. All other marks are the property of their respective owners.

The contents of this publication are presented for informational purposes only, and while every effort has been made to ensure their accuracy, they are not to be construed as warranties or guarantees, express or implied, regarding the products or services described herein or their use or applicability. All sales are governed by our terms and conditions, which are available upon request. We reserve the right to modify or improve the designs or specifications of such products at any time without notice.

Emerson Automation Solutions
Marshalltown, Iowa 50158 USA
Sorocaba, 18087 Brazil
Cernay 68700 France
Dubai, United Arab Emirates
Singapore 128461 Singapore

www.Fisher.com

