

2012-2021 **NV**

1500/2500/3500 CARGO VAN

BODY BUILDER'S GUIDE

NISSAN

Commercial Vehicles



SHIFT_the way you move

FOREWORD

This manual contains body builder's information for the 2012-2021 Model Years Nissan NV Cargo Van.

For your safety and the proper functioning of the vehicle, this guide should be read thoroughly.

All information in this guide is based on the latest product information at the time of publication. The right is reserved to make changes in specifications and methods at any time without notice. The most accurate and up to date information can be found on www.nissan-techinfo.com

Measurements found within this publication are for reference only. For exact measurements, contact Nissan Commercial and Fleet Aftermarket Engineering for CAD data.

IMPORTANT SAFETY NOTICE

The proper performance of procedures described in this guide is essential for both the safety of the technician and the proper functioning of the vehicle. The methods in this Body Builder's Guide are described in such a manner that they may be performed safely and accurately. Methods vary with the procedures used, the skills of the technician and the tools and parts available. Accordingly, anyone using procedures, tools or parts which are not specifically recommended by Nissan must first be completely satisfied that neither personal safety nor the vehicle's safety will be jeopardized by the method selected.



NISSAN NORTH AMERICA, INC.
Technical Publications Department

Edition: February 2012

Revision: September 2020

Publication Number: BG21EA0C80U0

CONTENTS

GENERAL INFORMATION	5	WEIGHTS — HIGH ROOF, 2021 MODEL YEAR	159
DISCLAIMER	5	INTERIOR MEASUREMENTS — HIGH ROOF	162
SERVICE INFORMATION AND TOOLS	6	EXTERIOR MEASUREMENTS — HIGH ROOF	164
CONTACT INFORMATION	7	BODY DIMENSIONS	167
WARRANTY	8	PASSENGER COMPARTMENT	167
DEFINITIONS OF TERMS	9	CARGO AREA	174
SAFETY INFORMATION	12	SIGN AREA — STANDARD ROOF	183
SUPPLEMENTAL RESTRAINT SYSTEM (SRS) PRE-CAUTIONS	12	SIGN AREA — HIGH ROOF	192
SUPPLEMENTAL RESTRAINT SYSTEM (SRS) COMPONENT LOCATIONS	13	PLACARDS	202
FRONT AIR BAG DEPLOYMENT ZONES	15	EXTERIOR	203
ALTERED VEHICLES	30	FRAME/BODY	213
BRAKE COMPLIANCE GUIDELINES	32	ELECTRICAL	215
CENTER OF GRAVITY (CG)	33	SELF-TEST MODE	215
FMVSS AND CMVSS REGULATION LIST	58	DATA LINK CONNECTOR LOCATION (FOR DIAGNOSTIC SCAN TOOL)	216
PRECAUTIONS	59	TRANSIT AND SHIPPING (EXTENDED STORAGE) MODE CONTROL SYSTEMS	217
MODEL INFORMATION	60	SHIPPING MODE (EXTENDED) STORAGE SYSTEM CANCEL	218
LABEL INFORMATION	60	FUSE AND RELAY INFORMATION	221
VEHICLE CODING INFORMATION	61	GROUNDING	228
CLASS	63	BATTERY VOLTAGE CONTROL SYSTEM	229
GVWR/TOWING CAPACITY	80	BATTERY VOLTAGE CONNECTION	230
VAN OPTION MASS — 2012-2013 MODEL YEARS	82	CUSTOMER PRE-WIRING ACCESS	231
VAN OPTION MASS — 2014 MODEL YEAR	84	HARNESS LAYOUT	235
VAN OPTION MASS — 2015-2016 MODEL YEARS	86	BULBS	260
VAN OPTION MASS — 2017 MODEL YEAR	88	HEADLAMP AIMING	261
VAN OPTION MASS — 2018 MODEL YEAR	90	FRONT FOG LAMP AIMING	264
VAN OPTION MASS — 2019 MODEL YEAR	91	ADDING LIGHTS OR DEVICES	265
VAN OPTION MASS — 2020 MODEL YEAR	92	REGULATIONS FOR ADDING COMMUNICATION EQUIPMENT	266
VAN OPTION MASS — 2021 MODEL YEAR	93	INVERTER SYSTEM	267
RESOURCE CHARTS	94	REMOTE KEYLESS ENTRY SYSTEM	270
WEIGHTS — STANDARD ROOF, 2012 MODEL YEAR	94	FUEL SYSTEMS	271
WEIGHTS — STANDARD ROOF, 2013-2014 MODEL YEARS	97	FUEL SYSTEM PRECAUTIONS	271
WEIGHTS — STANDARD ROOF, 2015-2016 MODEL YEARS	101	FILLER NECK AREAS	273
WEIGHTS — STANDARD ROOF, 2017 MODEL YEAR	105	TANK LOCATION	275
WEIGHTS — STANDARD ROOF, 2018 MODEL YEAR	109	TRAILER TOW	281
WEIGHTS — STANDARD ROOF, 2019 MODEL YEAR	113	WIRING	281
WEIGHTS — STANDARD ROOF, 2020 MODEL YEAR	117	BRAKE CONTROLLER	286
WEIGHTS — STANDARD ROOF, 2021 MODEL YEAR	121	TRAILER HITCH	288
INTERIOR MEASUREMENTS — STANDARD ROOF	125	DESIGN REQUIREMENTS FOR MODIFICATIONS	291
EXTERIOR MEASUREMENTS — STANDARD ROOF	127	COOLING	291
WEIGHTS — HIGH ROOF, 2012 MODEL YEAR	132	HVAC	292
WEIGHTS — HIGH ROOF, 2013-2014 MODEL YEARS	135	SONAR SYSTEM	293
WEIGHTS — HIGH ROOF, 2015-2016 MODEL YEARS	138	EXHAUST	295
WEIGHTS — HIGH ROOF, 2017 MODEL YEAR	143	WHEEL AND TIRE	299
WEIGHTS — HIGH ROOF, 2018 MODEL YEAR	147	STEERING AND SUSPENSION	300
WEIGHTS — HIGH ROOF, 2019 MODEL YEAR	151	DRIVELINE	301
WEIGHTS — HIGH ROOF, 2020 MODEL YEAR	155	TRANSMISSION	302
		FRAME	303
		JACK	304
		HIGH STRENGTH STEEL LOCATIONS	307
		WELDING	309
		VEHICLE INTERIOR	310
		PAINT GENERAL INFORMATION	311
		PAINT WORK — 2012 MODEL YEAR	312
		PAINT WORK — 2013 MODEL YEAR	313
		PAINT WORK — 2014 MODEL YEAR	314

PAINT WORK — 2015 MODEL YEAR	315	SUSPENSION	347
PAINT WORK — 2016-2020 MODEL YEARS	317	TURNING RADIUS	350
PAINT WORK — STARTING WITH 2021 MODEL YEAR	319	WHEEL AND TIRE	351
ADHESIVE INFORMATION	321	BULBS	352
REPLACING BOLTS	322	BATTERY	353
ADD ON EQUIPMENT	323	INVERTER SPECIFICATIONS	354
ANTI-CORROSION PROTECTION	323	OVERHEAD BIN LOAD LIMIT	355
SHELVING AND BULKHEAD INSTALLATION	324	ACRONYMS	356
ROOF RACKS	333	CONVERSION CHARTS	358
SPECIFICATIONS	336	METRIC-ENGLISH CONVERSION CHART	358
RECOMMENDED FLUIDS AND LUBRICANTS — USA AND CANADA	336	INCH-MILLIMETER EQUIVALENTS CHART	360
RECOMMENDED FLUIDS AND LUBRICANTS — MEXICO	343	INDEX	361

GENERAL INFORMATION

DISCLAIMER

Important Regulatory Information

Emission standards and motor vehicle safety standards for new vehicles and equipment have been established by the United States and Canadian Governments under the provisions of the Clean Air Act, the Noise Control Act, and the National Traffic and Motor Vehicle Safety Act in the U.S., and the Canadian Motor Vehicle Safety Act in Canada. These Acts govern Nissan as the original equipment manufacturer of the Nissan NV Cargo Vans. They also govern dealers, body builders, and all others who manufacture and market new motor vehicles and equipment. Part 568 of the Title 49 Code of Federal Regulations (CFR) describes requirements for intermediate manufacturers, final-stage manufacturers, and manufacturers who assume legal responsibility for a vehicle. This Body Builder's Guide (Guide) partially fulfills Nissan's obligations as the original equipment manufacturer. Additionally, this guide identifies regulatory requirements to assist intermediate and final stage manufacturers to determine their obligations to conform with these standards.

Compliance labels affixed to Nissan NV Cargo Vans indicate the status of initial compliance as of the date of manufacture by Nissan. Any subsequent modifications made to this vehicle may affect the final certification of the engine, vehicle or equipment. The body builder, conversion company, or dealer responsible for any modification has the responsibility to certify that the modified vehicle and equipment complies or continues to comply with all applicable motor vehicle safety standards and emissions regulations. The body builder, conversion company, or dealer is responsible for making sure the modifications or installed equipment do not affect the safety of the vehicle, including modifications which may result in a collision, property damage, personal injury or death.

Nissan does not assume responsibility as the final stage manufacturer for modified or altered vehicles. Nissan is not responsible for final certification, product liability claims, or warranty claims, resulting from any component, assembly, or system altered by or at the request of the body builder, conversion company, dealer or vehicle purchaser. Nissan is not responsible for modifications which cause the vehicle to become noncompliant with any of the motor vehicle safety standards, emissions regulations, or modifications that cause the vehicle to be or become defective or unsafe.

Disclaimer

All information, specifications and illustrations in this manual are those in effect at the time of printing. Nissan reserves the right to change specifications or design without notice and without obligation.

The body builder, conversion company, aftermarket equipment manufacturer, second stage manufacturer, upfitter, dealer and the vehicle purchaser are responsible to abide by all regulations issued by the National Highway Traffic Safety Administration (NHTSA), the Occupational Safety and Health Act (OSHA), state, local, or provincial government laws. These regulations and laws may require the installation of additional equipment for the intended use of the vehicle.

© 2020 Nissan North America, Inc. All rights reserved. No part of this Body Builder's Guide may be reproduced or stored in a retrieval system, or transmitted in any form, or by any means, electronic, mechanical, photocopying, recording or otherwise, without the prior written permission of Nissan North America, Inc.

SERVICE INFORMATION AND TOOLS

For service information, refer to www.nissan-techinfo.com.

For special service tools, refer to www.nissantechmate.com.

CONTACT INFORMATION

General

Nissan Commercial and Fleet Aftermarket Engineering 1 (855) 651-6655 or by E-mail at Nissan-AET@Nissan-USA.COM.

WARRANTY**Emissions Control System Warranty**

For Nissan warranty information, refer to the Warranty Information Booklet in the Owner's Manual package.

DEFINITIONS OF TERMS

The following definitions are from Title 49, Code of Federal Regulations, Parts 567.3, 568.3 and 571.3 where noted. Canadian definitions are from Canada Motor Vehicle Safety Regulations, Section 2(1), and are in italics. Nissan definitions are for the purpose of this publication only. Some terms are followed by an abbreviation that is used throughout this publication.

USA

Accessory Reserve Capacity (ARC) — Represents the amount of bolt-on accessory or modification weight permanently attached to a certified vehicle before its unloaded vehicle weight exceeds the unloaded vehicle weight for which Nissan has established FMVSS/CMVSS compliance. Accessory Reserve Capacity designations assume the use of permanently attached components resulting in center of gravity locations generally similar to those of comparable completed vehicles. Any additions or alterations that significantly affect the center of gravity of the total unit could impose more severe conditions than those for which Nissan has established compliance to FMVSS and CMVSS requirements.

Center of Gravity (CG) — The center of mass of a body or system.

Completed Vehicle — A vehicle that requires no further manufacturing operations to perform its intended function, other than the addition of readily attachable components, such as mirrors or tire and rim assemblies, or minor finishing operations such as painting. (49CFR568.3)

Curb Weight — Is the weight of a motor vehicle with standard equipment; maximum capacity of engine fuel, oil, and coolant; and if so equipped, air conditioning and additional weight optional engine. (49CFR571.3)

Engine Control Module (ECM) — The ECM consists of a microcomputer and connectors for signal input and output and for the power supply. The ECM also controls the engine.

Gross Combination Weight Rating (GCWR) — The value specified by the manufacturer as the loaded weight of a combination vehicle. (49CFR571.3)

Gross Vehicle Weight Rating (GVWR) — The value specified by the manufacturer as the loaded weight of a single vehicle. (49CFR571.3)

HO2 Heated Oxygen Sensor — The sensor after the three-way catalyst (manifold) that monitors the oxygen level in the exhaust gas on each bank.

Lamps, Reflective Devices, and Associated Equipment — A lamp that is mounted on a multipurpose passenger vehicle, truck, or bus for the purpose of providing illumination to load or unload cargo.

Maximum Payload — Maximum allowable weight that can be placed in the vehicle, including driver, passengers and aftermarket equipment. Value is reduced by adding optional equipment.

Seating system— Any seating position that can be adjusted to conform to different configurations.

SgRP — The theoretical hip point used by manufacturers when designing a vehicle. More specifically, it describes the relative position of the seated dummy's hip point when the seat is set in the rearmost and lowermost seating position. Also known as the "R-point" (reference point).

Stop Lamp Switch — An electrically powered switch that sends a signal to the BCM, to turn on the stop lamps, when the brake pedal is depressed.

Throttle Position Sensor (TPS) — The electric throttle control actuator that consists of the throttle control motor, throttle position sensor, etc. The throttle position sensor responds to the throttle valve movement.

Truck — A motor vehicle with motive power, except a trailer, designed primarily for the transportation of property or special purpose equipment. (49CFR571.3)

Unloaded Vehicle Weight (UVW) — Weight of a vehicle with maximum capacity of all fluids necessary for operation of the vehicle, but without cargo, occupants, or accessories that are ordinarily removed from the vehicle when it is not in use. (49CFR571.3)

Walk-In Van — A van type of truck in which a person having a height of 1,700 mm (66.93 in) can enter the occupant compartment in an upright position by a front door.

Canada

Accessory Reserve Capacity (ARC) — Represents the amount of bolt-on accessory or modification weight permanently attached to a certified vehicle before its unloaded vehicle weight exceeds the unloaded vehicle weight for which Nissan has established FMVSS/CMVSS compliance. Accessory Reserve Capacity designations assume the use of permanently attached components resulting in center of gravity locations generally similar to those of comparable completed vehicles. Any additions or alterations that significantly affect the center of gravity of the total unit could impose more severe conditions than those for which Nissan has established compliance to FMVSS and CMVSS requirements.

Center of Gravity (CG) — The center of mass of a body or system.

Completed Vehicle — A vehicle that needs no further manufacturing operations to perform its intended function, other than the addition of readily attachable components, such as minor finishing operations such as painting.

Curb Weight — Is the weight of a vehicle with standard equipment and carrying its maximum capacity of fuel, oil, and coolant and includes the weight of any air conditioning equipment on the vehicle and the amount by which the weight of any optional engine with which the vehicle is equipped exceeds the weight of the standard engine.

Engine Control Module (ECM) — The ECM consists of a microcomputer and connectors for signal input and output and for the power supply. The ECM also controls the engine.

Gross Combination Weight Rating — The value specified by the manufacturer as the loaded weight of a combination vehicle.

Gross Vehicle Weight Rating or "GVWR" — The value specified by the vehicle manufacturer as the loaded weight of a single vehicle.

H02 Heated Oxygen Sensor — The sensor after the three-way catalyst (manifold) that monitors the oxygen level in the exhaust gas on each bank.

Lamps, Reflective Devices, and Associated Equipment — A lamp that is mounted on a multipurpose passenger vehicle, truck, or bus for the purpose of providing illumination to load or unload cargo or passenger.

Maximum Payload — Maximum allowable weight that can be placed in the vehicle, including driver, passengers and aftermarket equipment. Value is reduced by adding optional equipment.

Seating System — Any seating position that can be adjusted to conform to different configurations.

SgRP — The theoretical hip point used by manufacturers when designing a vehicle. More specifically, it describes the relative position of the seated dummy's hip point when the seat is set in the rearmost and lowermost seating position. Also known as the "R-point" (reference point).

Stop Lamp Switch — An electrically powered switch that sends a signal to the BCM, to turn on the stop lamps, when the brake pedal is depressed.

Throttle Position Sensor (TPS) — The electric throttle control actuator consisting of the throttle control motor, throttle position sensor, etc. The throttle position sensor responds to the throttle valve movement.

Truck — A motor vehicle designed primarily for the transportation of property or special-purpose equipment, but does not include a competition vehicle, a crawler-mounted vehicle, a three-wheeled vehicle, a trailer, a work vehicle, a vehicle imported temporarily for special purposes, a vehicle designed for operation exclusively off-road or a low-speed vehicle.

Unloaded Vehicle Weight (UVW) — Weight of a vehicle with maximum capacity of all fluids necessary for operation of the vehicle, but without cargo, occupants, or accessories that are ordinarily removed from the vehicle when it is not in use.

Walk In Van — A van type of truck in which a person having a height of 1,700 mm (66.93 in) can enter the occupant compartment in an upright position by a front door.

SAFETY INFORMATION

SUPPLEMENTAL RESTRAINT SYSTEM (SRS) PRECAUTIONS

Precautions for Supplemental Restraint System (SRS) "Air Bag" and "Belt Pre-Tensioner"

**WARNING:**

Always observe the following items for preventing accidental activation:

- To avoid rendering the SRS inoperative, which could increase the risk of personal injury or death in the event of a collision which could result in air bag inflation, it is recommended that all maintenance and repair be performed by an authorized NISSAN/INFINITI dealer.
- Improper repair, including incorrect removal and installation of the SRS, can lead to personal injury caused by unintentional activation of the system or failure of the system to work properly in the event of an accident.
- To avoid rendering the SRS inoperative, which could increase the risk of personal injury or death in the event of a collision which would result in air bag inflation, the front passenger seat cannot be permanently removed.
- Never use electrical test equipment on any circuit related to the SRS. SRS wiring harnesses can be identified by yellow and/or orange harnesses or harness connectors.

Precautions When Using Power Tools (Air or Electric) and Hammers

**WARNING:**

Always observe the following items for preventing accidental activation:

- To avoid rendering the SRS inoperative, which could increase the risk of personal injury or death in the event of a collision which could result in air bag inflation, it is recommended that all maintenance and repair be performed by an authorized NISSAN/INFINITI dealer.
- Improper repair, including incorrect removal and installation of the SRS, can lead to personal injury caused by unintentional activation of the system or failure of the system to work properly in the event of an accident.
- To avoid rendering the SRS inoperative, which could increase the risk of personal injury or death in the event of a collision which would result in air bag inflation, the front passenger seat cannot be permanently removed.
- Never use electrical test equipment on any circuit related to the SRS. SRS wiring harnesses can be identified by yellow and/or orange harnesses or harness connectors.

SUPPLEMENTAL RESTRAINT SYSTEM (SRS) COMPONENT LOCATIONS

[SAFETY INFORMATION]

SUPPLEMENTAL RESTRAINT SYSTEM (SRS) COMPONENT LOCATIONS

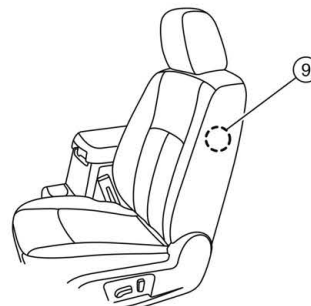
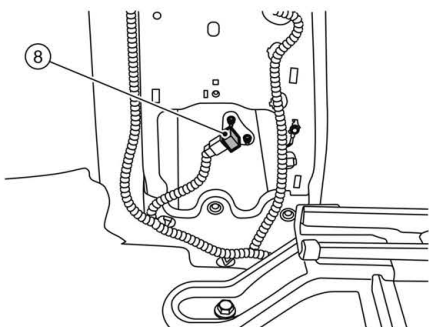
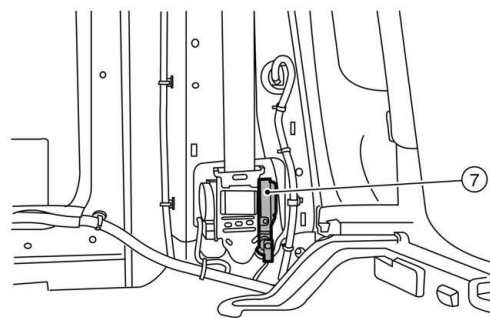
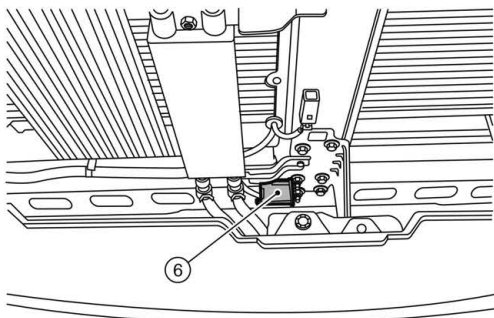
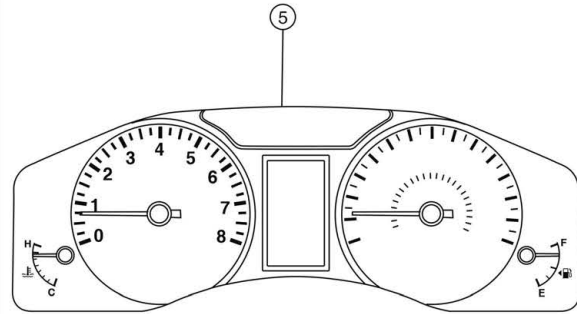
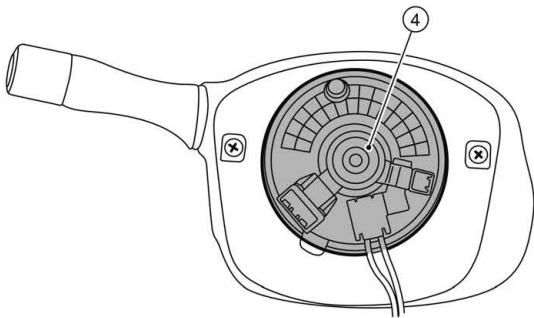
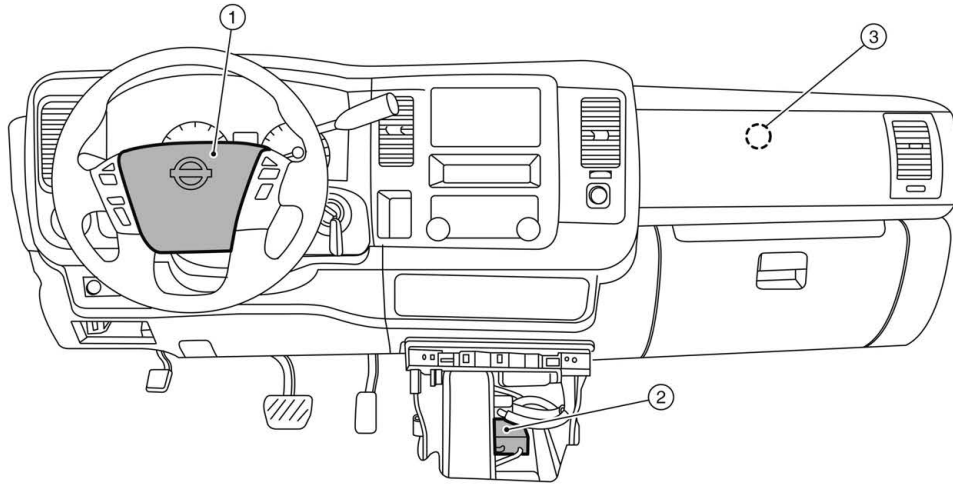

TGAZIA0066ZZ

SUPPLEMENTAL RESTRAINT SYSTEM (SRS) COMPONENT LOCATIONS

[SAFETY INFORMATION]

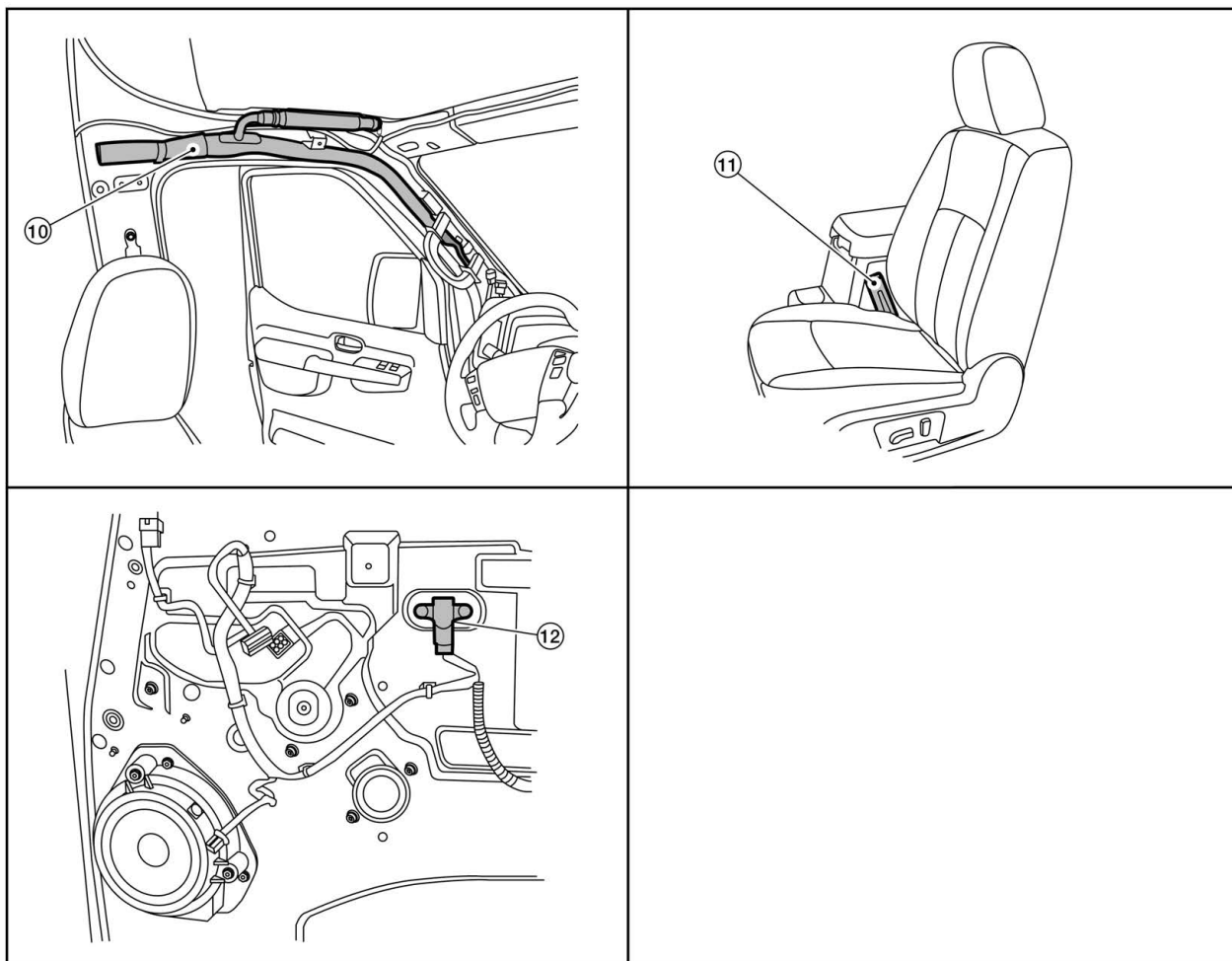

AAZIA0861ZZ

- | | |
|---|---|
| <ul style="list-style-type: none"> 1. Driver air bag module 3. Front passenger air bag module 5. Instrument cluster (SRS warning light) 7. Front LH seat belt pre-tensioner (RH similar) (view with lower center pillar cover removed) 9. Front LH side air bag module (RH similar) 11. Seat belt buckle switch LH (RH similar) | <ul style="list-style-type: none"> 2. Air bag diagnosis sensor unit (view with instrument panel lower center cover removed) 4. Spiral cable (view with steering wheel removed) 6. Crash zone sensor (view with front grille removed) 8. Front side air bag satellite sensor LH (RH similar) (view with front LH seat belt pre-tensioner removed) 10. LH side front curtain air bag module (RH similar) (view with headliner and A-pillar trim removed) 12. Front door satellite sensor RH (If equipped) (LH similar)* |
|---|---|

* Starting with 2016 model year

FRONT AIR BAG DEPLOYMENT ZONES

FRONT AIR BAG MODULE LOCATIONS



WARNING:

Modifications must not interfere with air bag modules or deployment zones. Damage to air bag modules may cause serious personal injury or death. Objects placed within air bag deployment zones may cause serious personal injury or death.

NOTE:

Do not add accessory items that, when installed, will interfere with the installed position of the air bag or the zones of the deploying air bags.

FRONT AIR BAG DEPLOYMENT ZONES

[SAFETY INFORMATION]

Front Air Bag Modules – Overhead View

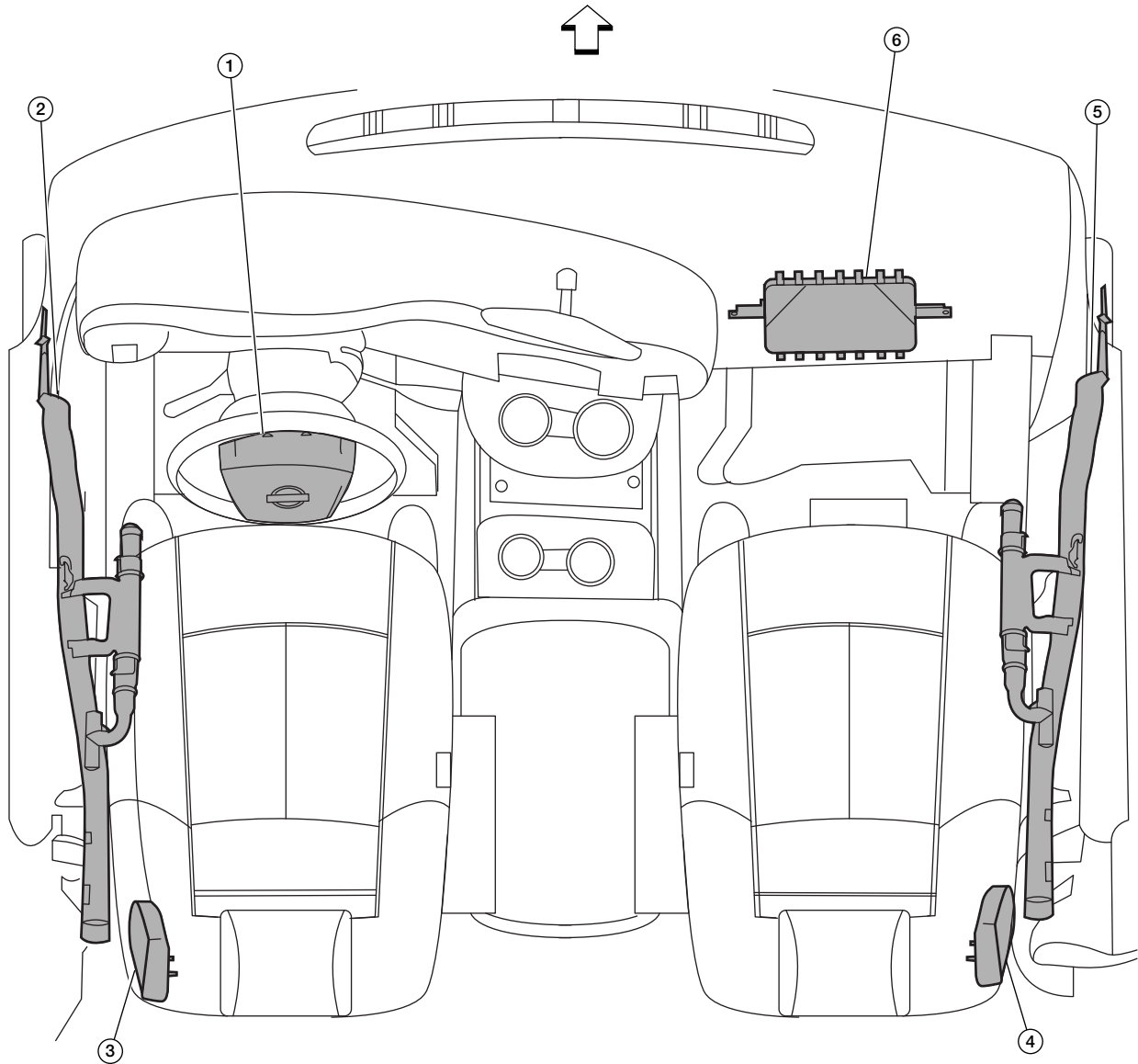

AAZIA0314ZZ

↔: Front of vehicle.

- | | | |
|-----------------------------------|---|--------------------------------|
| 1. Driver air bag | 2. Side curtain air bag module, driver | 3. Side air bag module, driver |
| 4. Side air bag module, passenger | 5. Side curtain air bag module, passenger | 6. Passenger air bag module |

FRONT AIR BAG DEPLOYMENT ZONES

[SAFETY INFORMATION]

Front Air Bag Modules – Driver Side

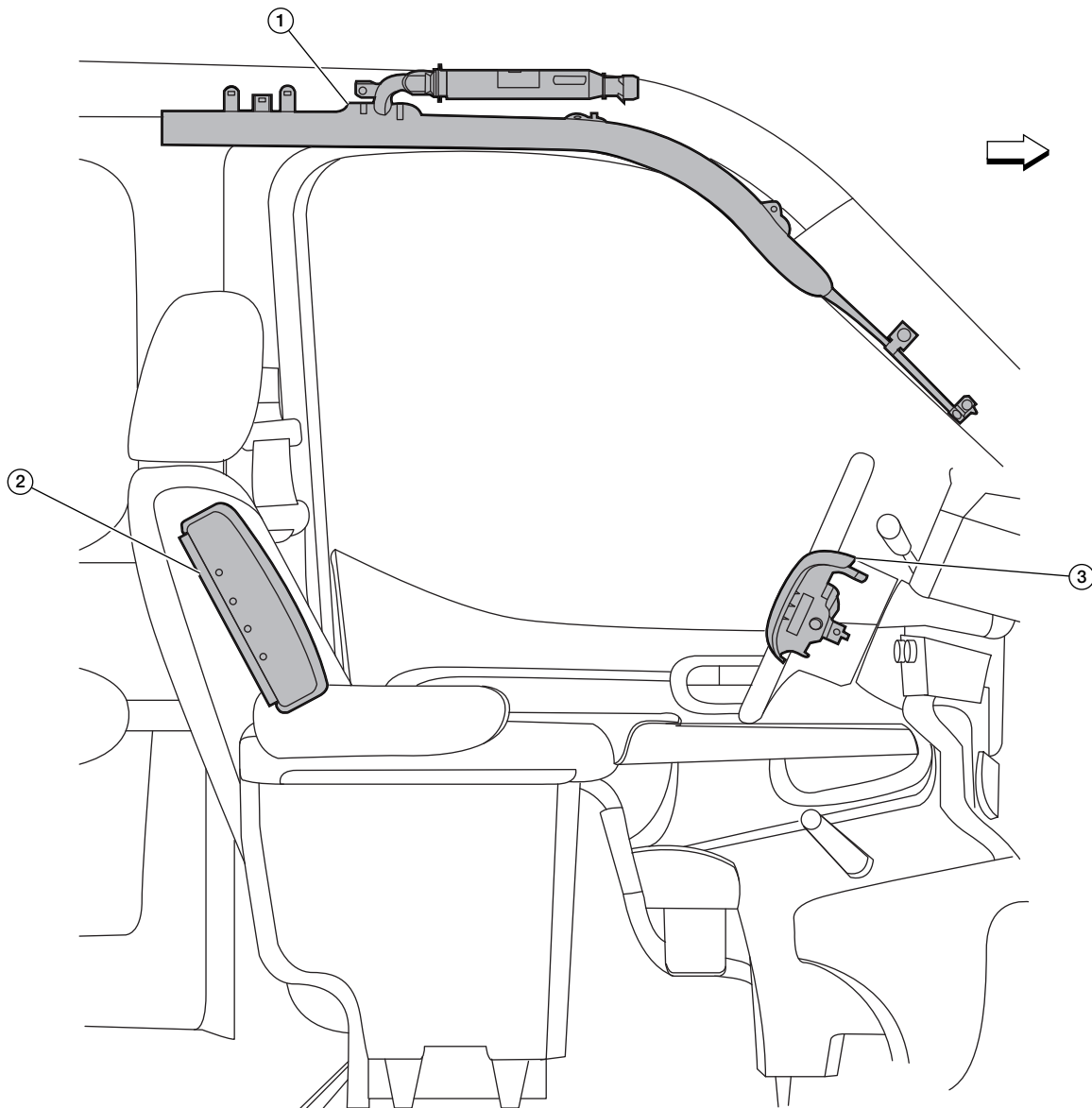

AAZIA0312ZZ

↔: Front of vehicle.

1. Side curtain air bag module

2. Side air bag module

3. Driver air bag module

FRONT AIR BAG DEPLOYMENT ZONES

[SAFETY INFORMATION]

Front Air Bag Modules — Passenger Side

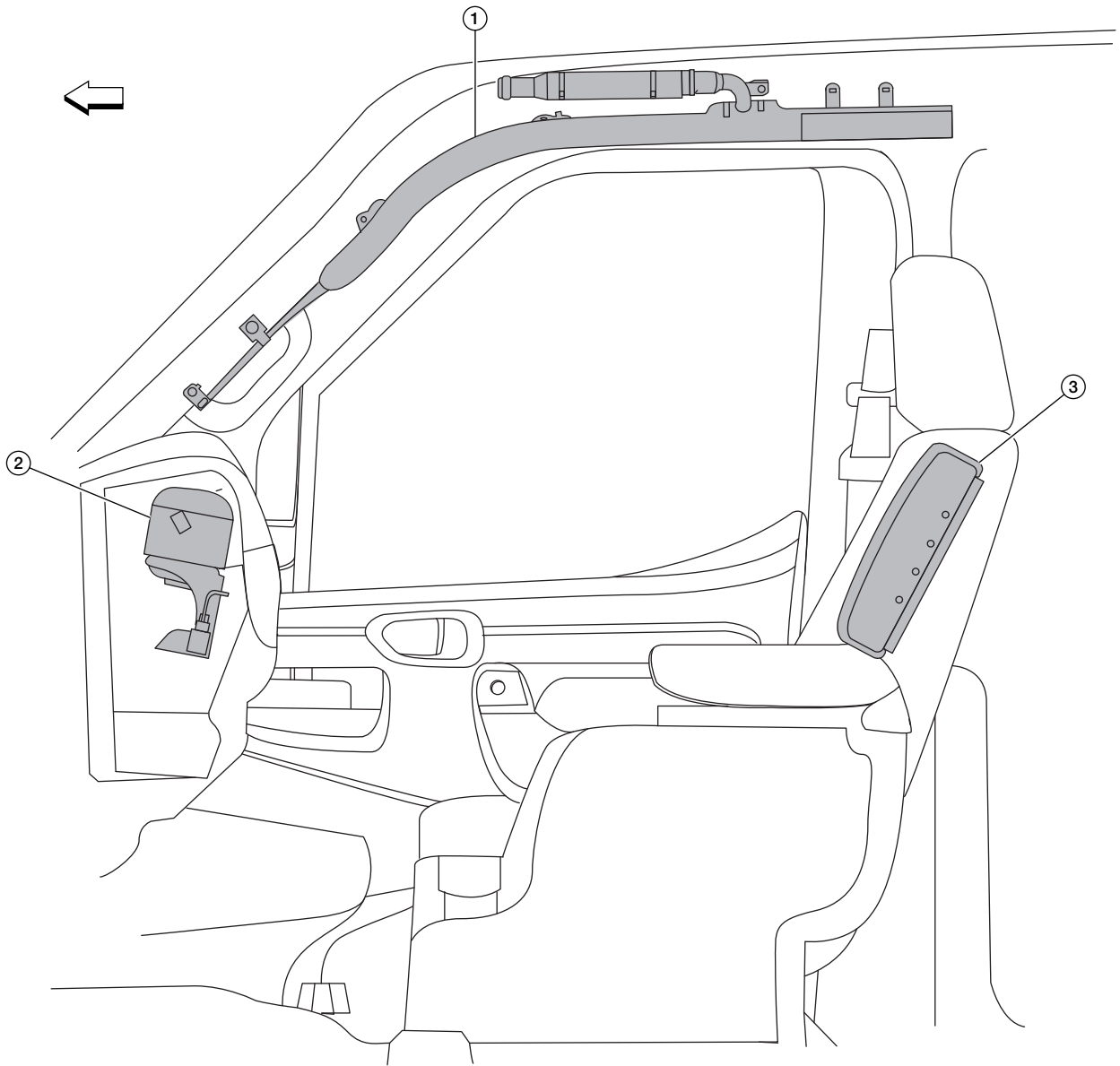

AAZIA0313ZZ

↖: Front of vehicle.

1. Side curtain air bag module

2. Passenger air bag module

3. Side air bag module

FRONT AIR BAG DEPLOYMENT ZONES

[SAFETY INFORMATION]

Driver Air Bag Deployment Width

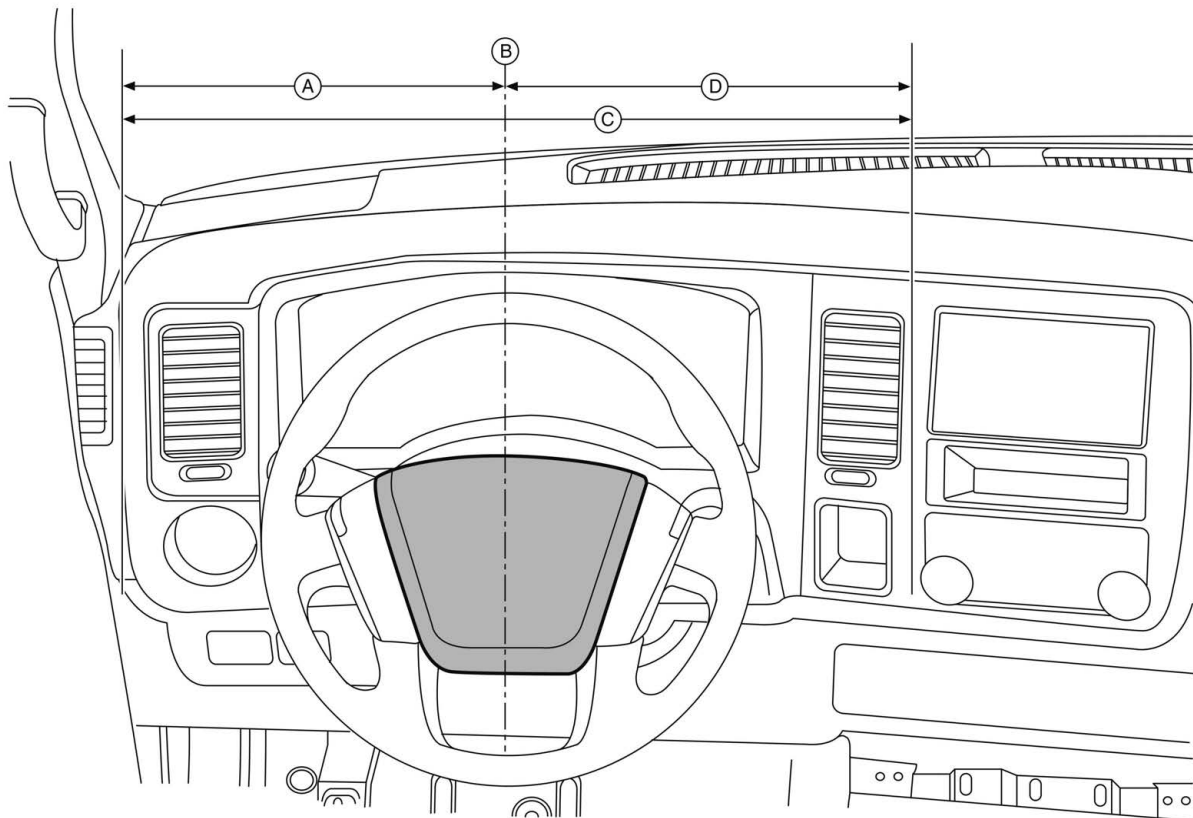

TGAAZIA0068ZZ

A. 300 mm (11.81 in)

B. Center of the driver air bag module housing

C. Maximum lateral projection of the deployed driver air bag 600 mm (23.6 in)

D. 300 mm (11.81 in)

Front Passenger Air Bag Deployment Width

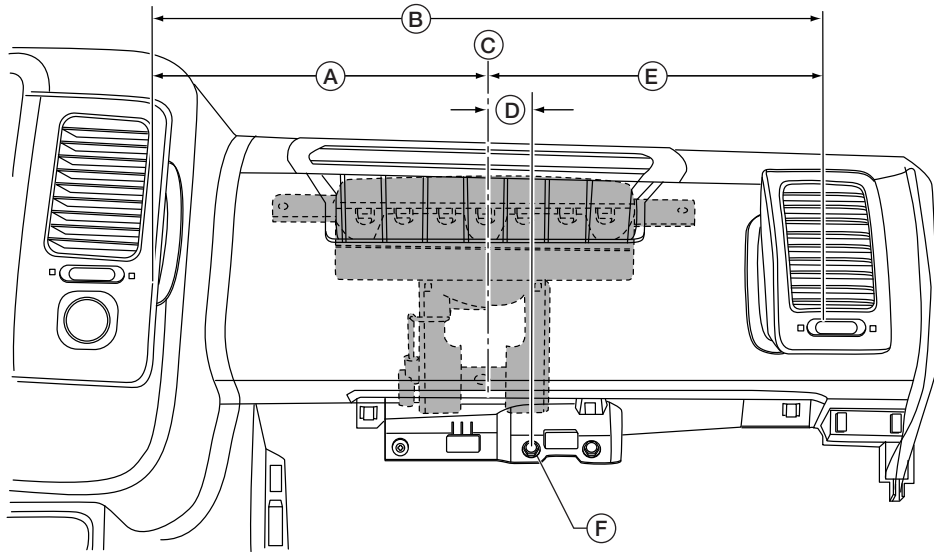

AAZIA0298ZZ

A. 305 mm (12.01 in)

B. Maximum lateral projection of the deployed passenger air bag 610 mm (24.02 in)

C. Center of passenger air bag module housing

D. 38.5 mm (1.52 in)

E. 305 mm (12.01 in)

F. Reference point: glove box striker inboard fastener

FRONT AIR BAG DEPLOYMENT ZONES

[SAFETY INFORMATION]

AIR BAG DEPLOYMENT KEEP-OUT ZONES

Front Air Bag Keep-Out Zones — Overhead View

 = Air Bag Deployment Keep-out Zone (No modifications in this area.)

 = Air Bag Inflation Zones

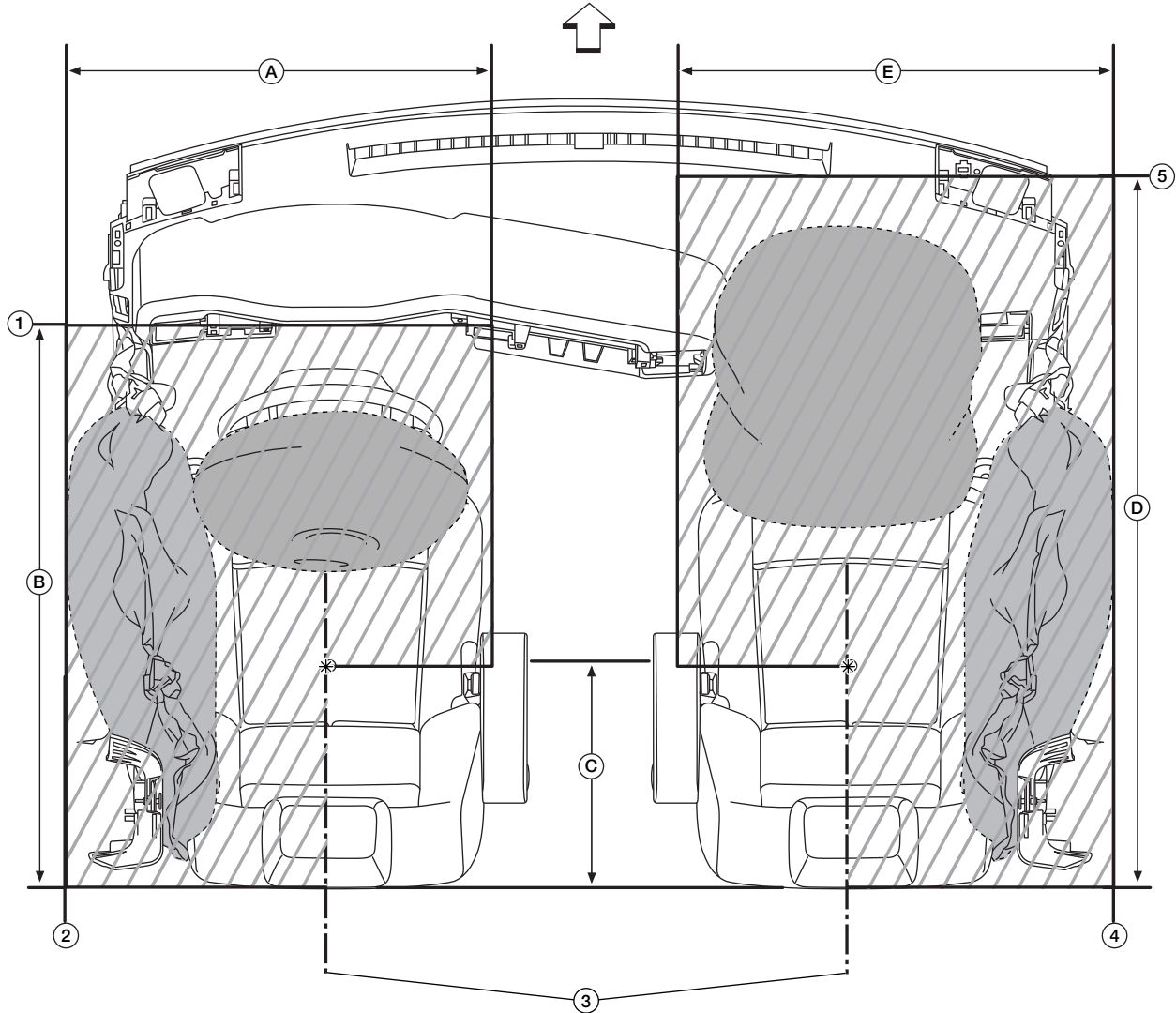

AAZIA0353GB

: Front of vehicle.

1. Reference point: instrument panel edge

4. Reference point: door glass trim edge

B. 1,108 mm (43.62 in)

E. 751 mm (29.57 in)

2. Reference point: door glass trim edge

5. Reference point: instrument panel seam

C. 433 mm (17.05 in)

3. Reference point: seat center lines

A. 743 mm (29.25 in)

D. 1,384 mm (54.49 in)

FRONT AIR BAG DEPLOYMENT ZONES

[SAFETY INFORMATION]

Front Air Bag Keep-Out Zone – Driver Side View

 = Air Bag Deployment Keep-out Zone (No modifications in this area.)

 = Air Bag Inflation Zones

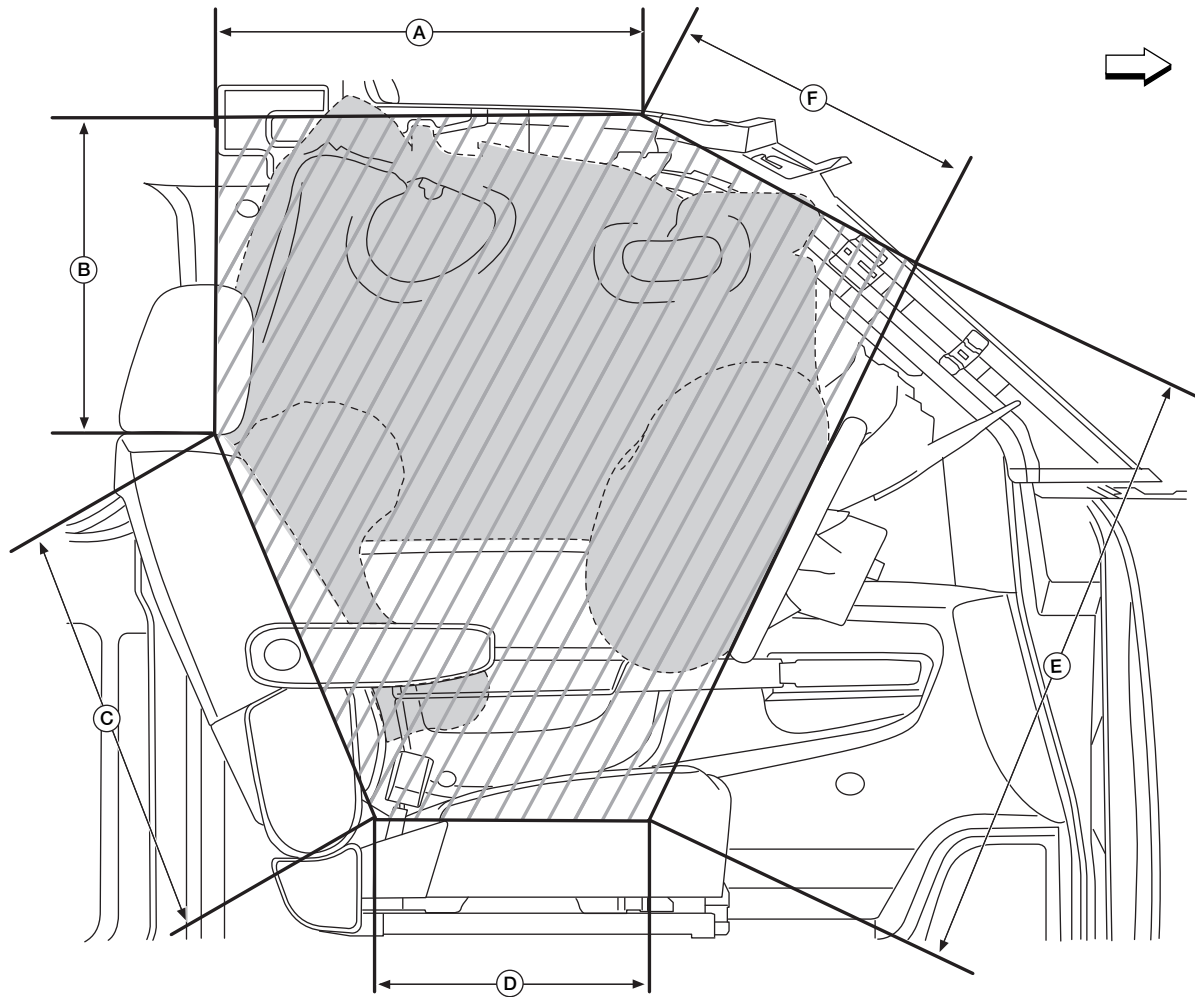

AAZIA0351GB

: Front of vehicle.

A. 662 mm (26.06 in)

B. 395 mm (15.55 in)

C. 642 mm (25.58 in)

D. 310 mm (12.20 in)

E. 905 mm (35.63 in)

F. 315 mm (12.40 in)

FRONT AIR BAG DEPLOYMENT ZONES

[SAFETY INFORMATION]

Front Air Bag Keep-Out Zone – Passenger Side View

 = Air Bag Deployment Keep-out Zone (No modifications in this area.)

 = Air Bag Inflation Zones

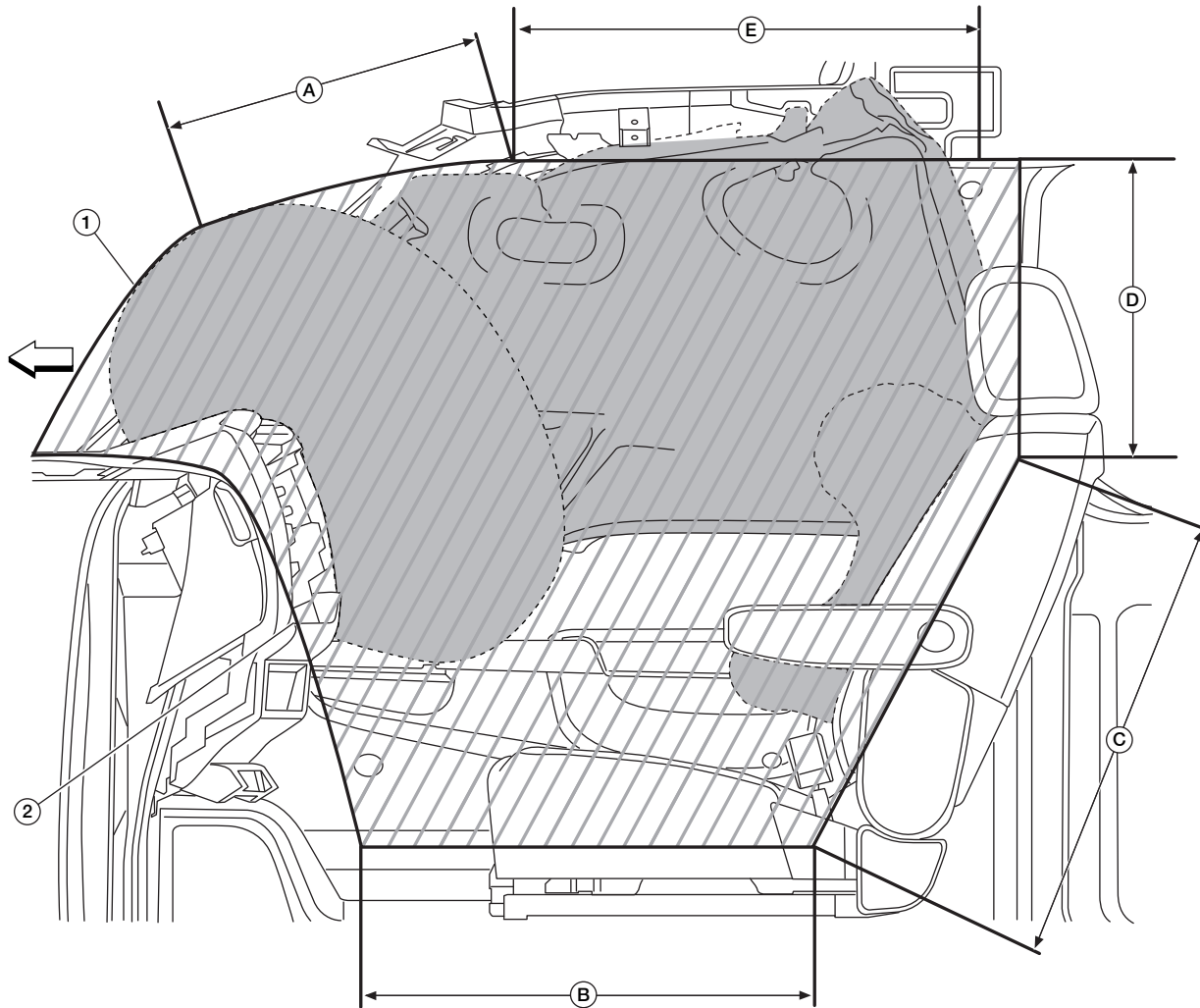

AAZIA0352GB

: Front of vehicle.

1. Reference point: zone follows windshield surface

2. Reference point: zone follows instrument panel surface contour

A. 366 mm (14.41 in)

B. 586 mm (23.07 in)

C. 637 mm (25.08 in)

D. 395 mm (15.55 in)

E. 662 (26.06 in)

FRONT AIR BAG DEPLOYMENT ZONES

[SAFETY INFORMATION]

INFLATED AIR BAG ZONE DIMENSIONS

Driver and Passenger Air Bag Inflation Zones — Forward View

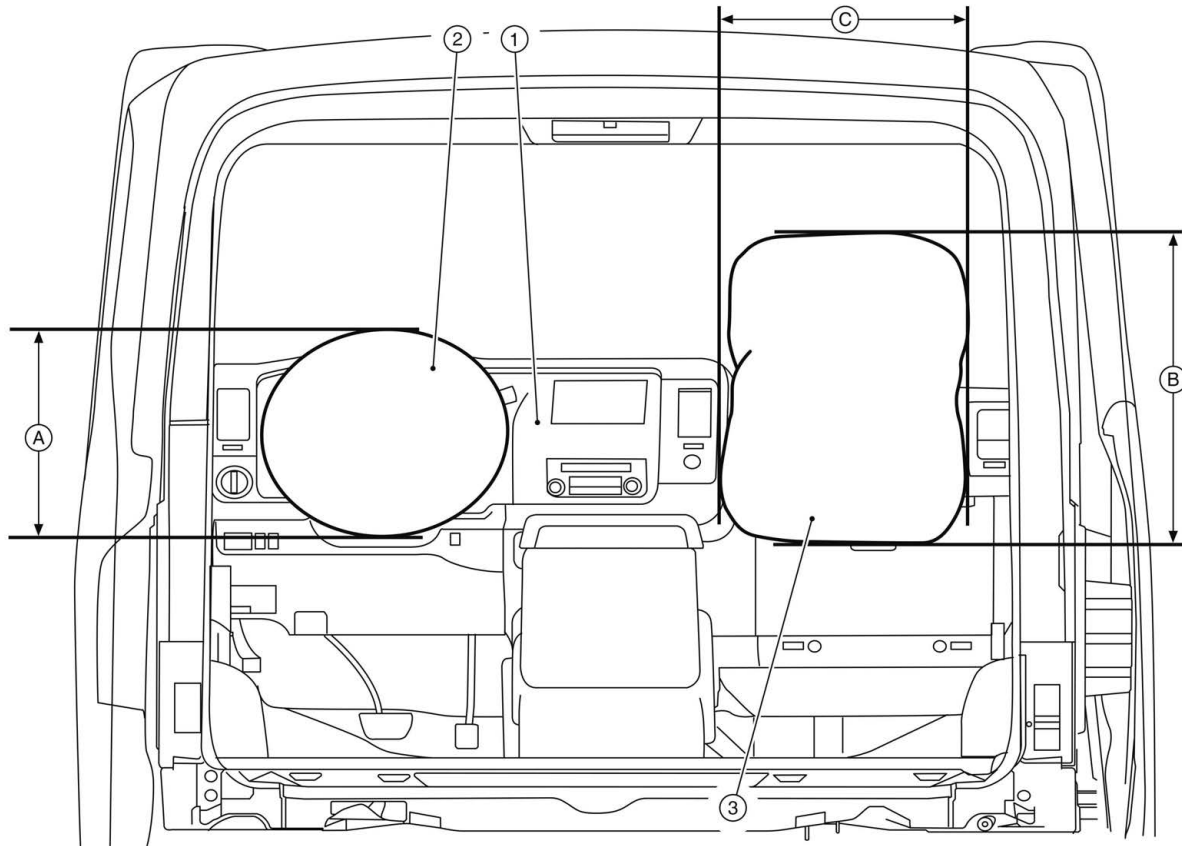

TGAAZIA0069ZZ

1. Reference point: front edge of instrument panel at centerline of driver air bag module

2. Maximum inflated driver air bag

3. Maximum inflated front passenger air bag

A. 481 mm (18.94 in)

B. 713 mm (28.07 in)

C. 480 mm (18.90 in)

FRONT AIR BAG DEPLOYMENT ZONES

[SAFETY INFORMATION]

Front Air Bag Inflation Zones — Overhead View

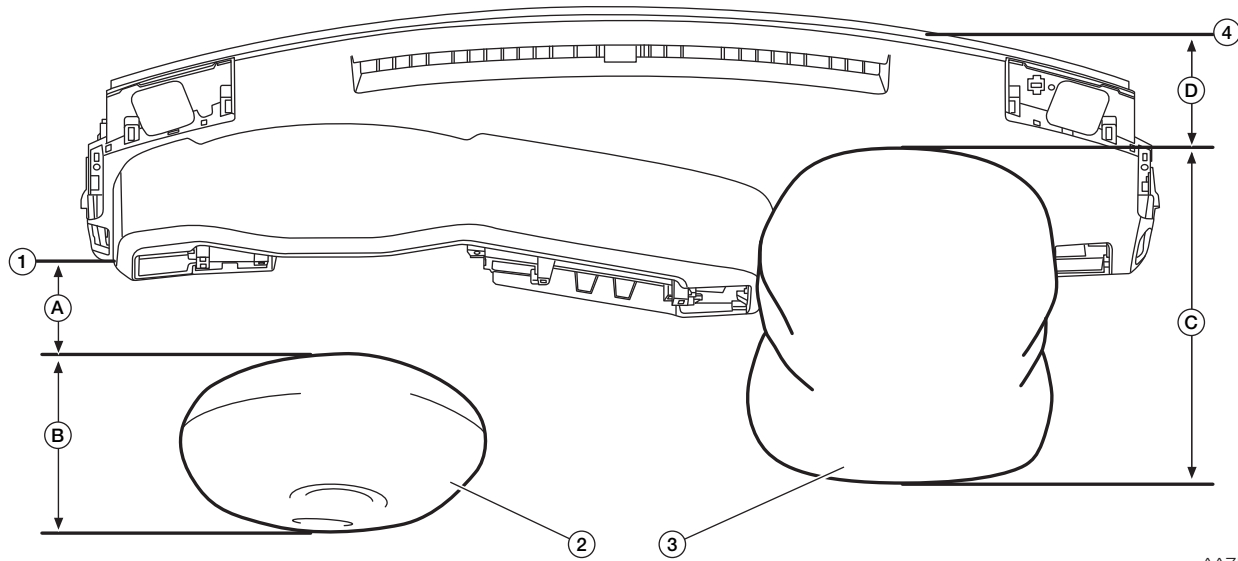

AAZIA0288ZZ

1. Reference point: front edge of instrument panel at centerline of driver air bag module

2. Maximum inflated driver air bag

3. Maximum inflated front passenger air bag

4. Reference point: mating point of windshield and instrument panel at center line of front passenger air bag

A. 190 mm (7.48 in)

B. 301 mm (11.85 in)

C. 599 mm (23.58 in)

D. 203 mm (7.99 in)

FRONT AIR BAG DEPLOYMENT ZONES

[SAFETY INFORMATION]

Front Air Bag Inflation Zones – Driver Side View

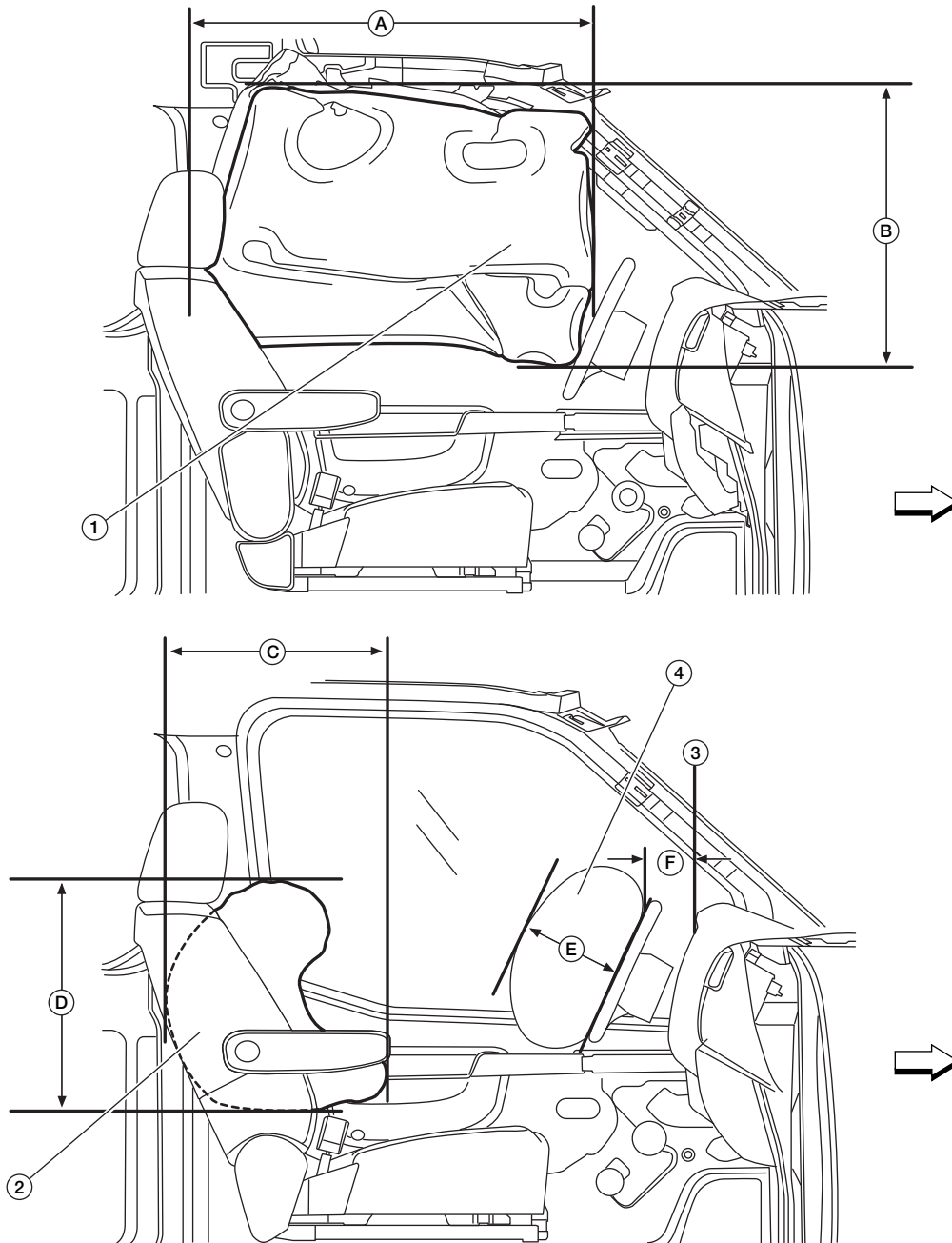

AAZIA0290ZZ

↔: Front of vehicle.

1. Maximum inflated side curtain air bag

4. Maximum inflated driver air bag

C. 408 mm (16.06 in)

F. 153 mm (6.02 in)

2. Maximum inflated side air bag

A. 856 mm (33.70 in)

D. 516 mm (20.31 in)

3. Reference point: front edge of instrument panel

B. 628 mm (24.72 in)

E. 240 mm (9.45 in)

FRONT AIR BAG DEPLOYMENT ZONES

[SAFETY INFORMATION]

Front Air Bag Inflation Zones — Passenger Side View

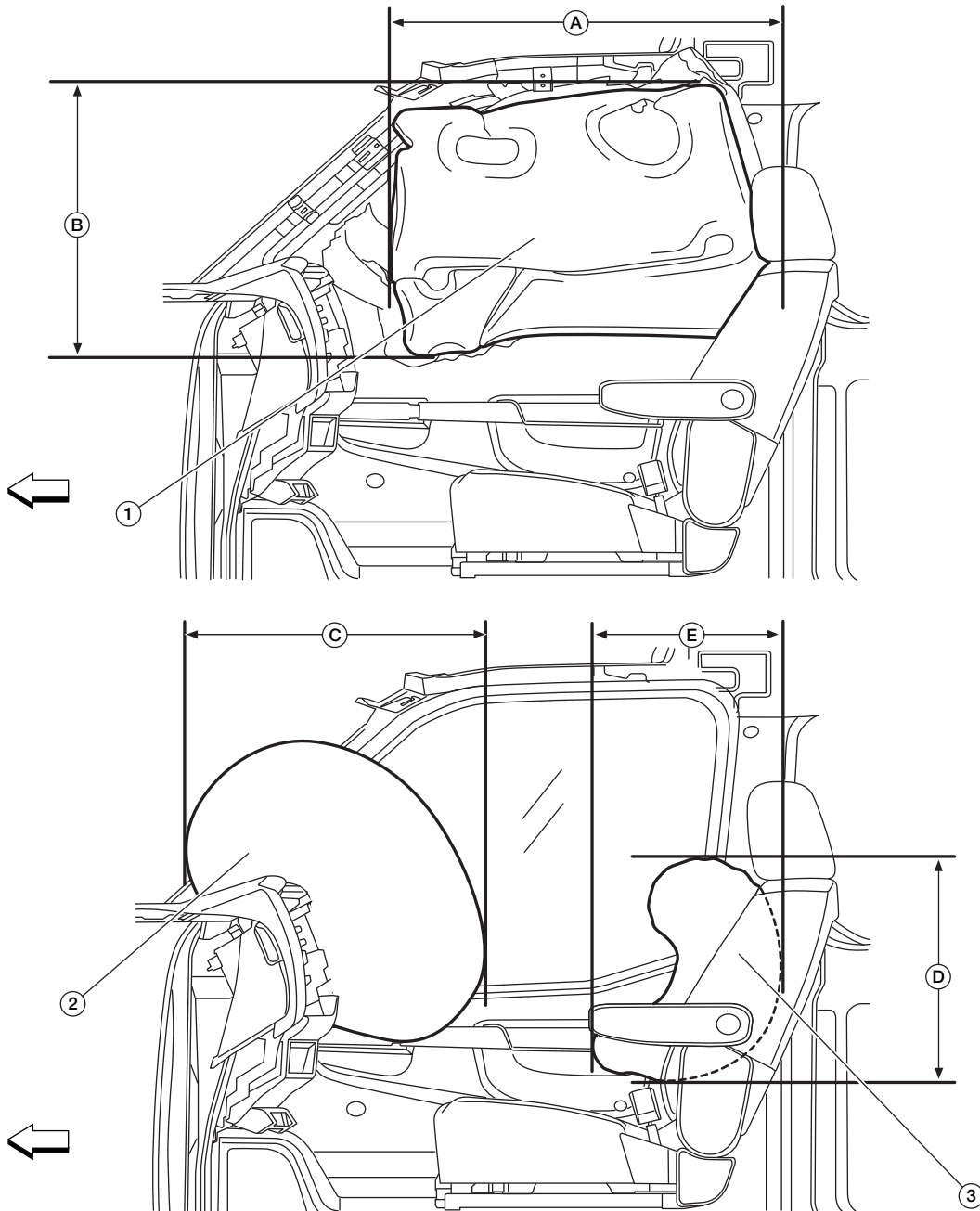

AAZIA0289ZZ

←: Front of vehicle.

1. Maximum inflated side curtain air bag

A. 856 mm (33.70 in)

D. 516 mm (20.31 in)

2. Maximum inflated passenger air bag

B. 628 mm (24.72 in)

E. 408 mm (16.06 in)

3. Maximum inflated side air bag

C. 578 mm (22.76 in)

FRONT AIR BAG DEPLOYMENT ZONES

[SAFETY INFORMATION]

Side Curtain Air Bag Inflation Zones – Overhead View

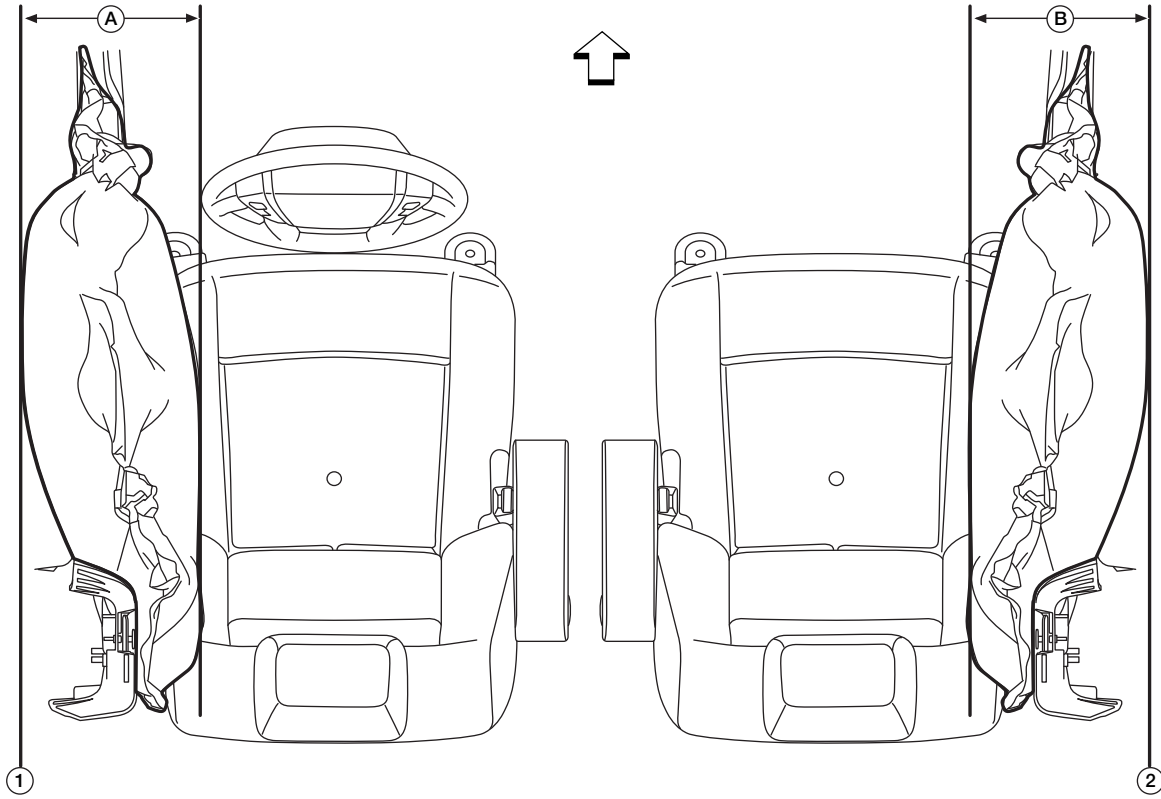

AAZIA0291ZZ

↔: Front of vehicle.

1. Reference point: door glass trim edge

2. Reference point: door glass trim edge

A. 257 mm (10.12 in)

B. 257 mm (10.12 in)

FRONT AIR BAG DEPLOYMENT ZONES

[SAFETY INFORMATION]

Side Air Bag Inflation Zones – Overhead View

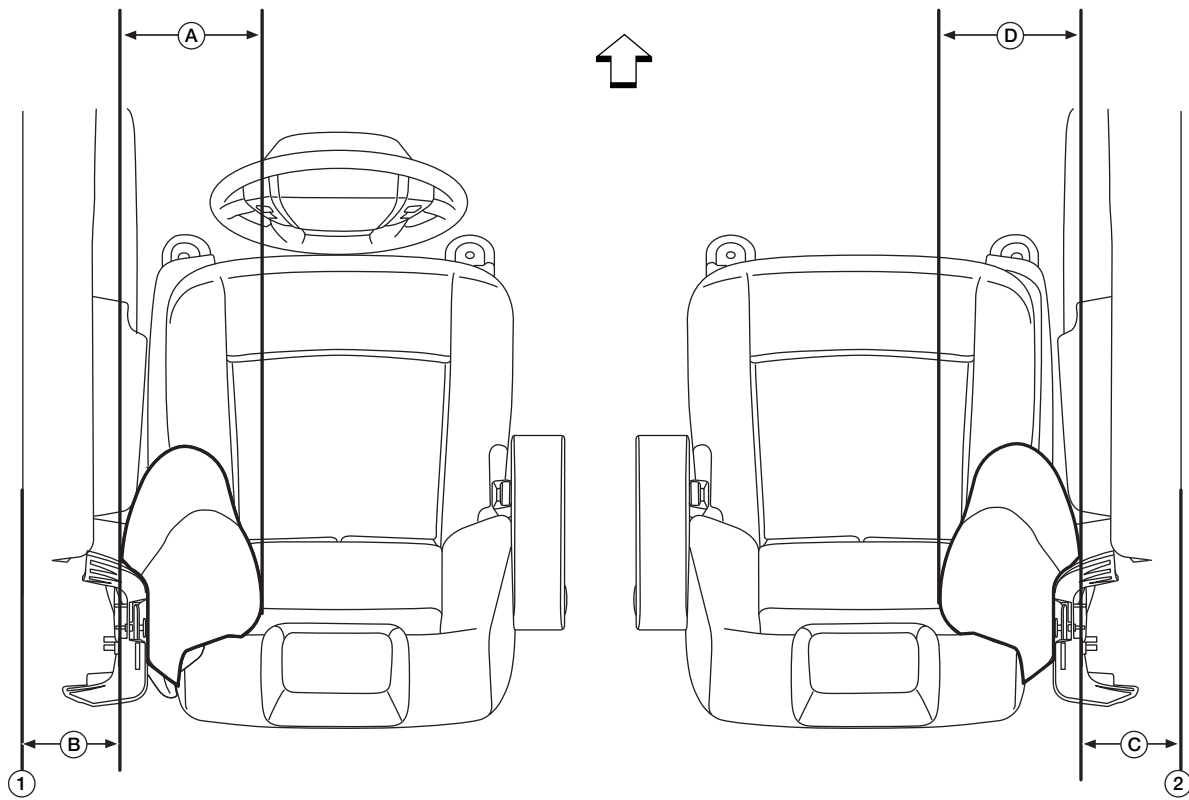

AAZIA0292ZZ

↖: Front of vehicle.

1. Reference point: door glass trim edge

B. 126 mm (4.96 in)

2. Reference point: door glass trim edge

C. 126 mm (4.96 in)

A. 211 mm (8.31 in)

D. 211 mm (8.31 in)

ALTERED VEHICLES

Safety / Emissions

Certification Labels for Altered Vehicles

USA:

A person or company who alters a previously certified vehicle before the first purchase by the final customer in such a manner that its stated weight ratings are revised, is required by Federal Regulation (49 CFR Part 567.7) to affix an Altered Vehicle Certification Label in addition to the FMVSS and CMVSS Certification Label. The label must be affixed to the vehicle in the manner and form described in 49 CFR Part 567.4:

- The label shall, unless riveted, be permanently affixed in such a manner that it cannot be removed without destroying or defacing it.
- The label shall be affixed to either the hinge pillar, B-pillar, or the door edge that meets the door-latch post next to the driver's seating position or, if none of these locations is practicable, to the left side of the instrument panel (other permissible locations are also specified in 49 CFR Part 567.4).
- The lettering on the label shall be of a color that contrasts with the background of the label.
- The label shall contain the required statements in the English language and lettered in block capitals and numerals not less than three thirty-seconds of an inch high.
- The lettering shall be permanent. If typed or written, a protective clear cover may be necessary to prevent information from being wiped off.
- Label must not cover or obscure the FMVSS or CMVSS Certification Label.

NOTE:

The National Highway Traffic Safety Administration (NHTSA) requires that any automobile dealer that installs accessories on a vehicle prior to first retail sale must install a special label ("reduced capacity label") on that vehicle if the total weight of all accessories on that vehicle exceed 1.5 percent of the vehicle's gross vehicle weight rating (GVWR) or 100 lbs., whichever is less. This includes accessories that the dealer puts on (OE and after market), AND accessories installed at the Vehicle Processing Center (VPC).

If the yellow "reduced capacity label" label is applied near the tire and loading information on the driver's side B pillar, the load carrying capacity shown on the yellow label supersedes previous load information.

Canada:

"Alterers" of motor vehicles are required to affix a permanent label on vehicles that they manufacture bearing a statement of compliance as provided by Section 9 of the Canadian Motor Vehicle Safety Regulations. The vehicle alterer should affix a corporate label containing information shown on this page.

- Insert the name of the company that altered the vehicle.
- Insert the month and year during which the alteration of the vehicle was completed.
- Insert a drawing of the National Safety Mark which includes their unique manufacturer number.
- Insert revised GVWR or PNBV capacities in kilograms of the vehicle as altered, where they differ from those shown on the original certification label.
- Insert the GAWR/PNBEs of the vehicle as altered, where they differ from those shown on the original certification label. Also, include the tire size, rim size and tire inflation pressure.
- Insert the vehicle type stated on the safety standard certification label provided by Nissan. The type of vehicle, in both official languages, or the word "TYPE" along with one of the following abbreviations, namely:
 - "AT/PA" to refer to an auto transporter,
 - "ATV/VTT" to refer to an all-terrain vehicle,
 - "B/A" to refer to a bus,
 - "BT/RA" to refer to a bus trailer,
 - "CD/CCC" to refer to a C-dolly,

- "CMC/MCC" to refer to a competition motorcycle,
- "LDD/CRC" to refer to a load divider dolly,
- "MH/AC" to refer to a motor home,
- "MC" to refer to a motorcycle,
- "MPV/VTUM" to refer to a multi-purpose passenger vehicle,
- "RUM/MUR" to refer to a restricted-use motorcycle,
- "SB/AS" to refer to a school bus,
- "TRA/REM" to refer to a trailer,
- "TCD/CDC" to refer to a trailer converter dolly,
- "TRU/CAM" to refer to a truck, and
- "TT/CT" to refer to a truck tractor.

The label must meet the following requirements as described in Section 9:

- Shall be permanently attached.
- Shall be affixed adjacent to the original compliance label required by Section 6.
- The lettering of the label shall be clear, indelible, indented, or embossed, or of a color that contrasts with the background color of the label, and in block capitals and numerals not less than 2.0 mm (0.1 in) high.
- The label shall be permanently affixed to the same surface as that to which the FMVSS or CMVSS label is affixed.

BRAKE COMPLIANCE GUIDELINES

Brake Compliance Guidelines (FMVSS and CMVSS 105)

The calculations and abbreviated definitions necessary for the Center of Gravity (CG) measurements are included in this manual.

Any changes to the vehicle must still comply with FMVSS and CMVSS 105 allowing for the following provisions:

- No alterations, modifications or replacements are made to the following systems:
 - parking brake
 - anti-lock brakes
 - engine vacuum
 - steering
 - wheels or tires
 - brakes
 - indicator lamps and wiring
 - brake system reservoir labeling
 - suspension ride height or spring rate
 - engine belt drive
- The vehicle is re-balanced by the addition of an equivalent weight if components are permanently removed.
- The applicable GAWRs and GVWR weights are not exceeded.
- The applicable center of gravity limitations are met using the calculation methods in [Center of Gravity \(CG\) \(pg. 33\)](#) section.
- The vertical distance from the ground to the completed vehicle center of gravity should not exceed 1,219.2 mm (48 in) at the Gross Vehicle Weight Rating (GVWR).

CENTER OF GRAVITY (CG)

Vehicle Center of Gravity Measurement Process

Introduction

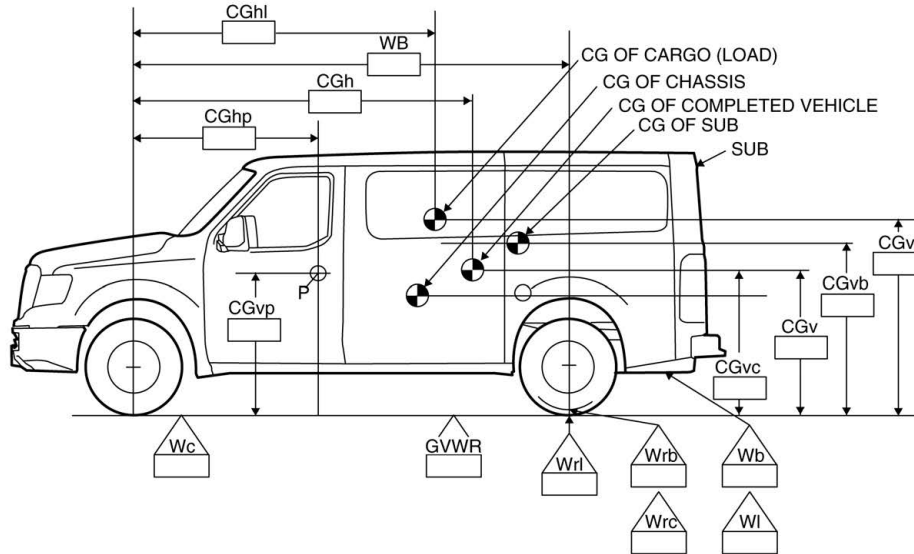

AAZIA0283GB

List of Terms

Term	Definition
CG_h	Horizontal distance from the center line of the front wheels to the center of gravity of the completed vehicle [mm (in)].
CG_{hl}	Horizontal distance from the center line of the front wheels to the center of gravity of the cargo [mm (in)]. If CG_{hl} is not known, it may be estimated as the distance from the center line of the front wheels to the horizontal midpoint of the cargo area.
CG_{hb}	Horizontal distance from the center line of the front wheels to the center of gravity of SUB and/or permanently attached equipment [mm (in)].
CG_{hp}	Horizontal distance from the center line of the front wheels to the center of gravity of the passenger load [mm (in)].
CG_v	Vertical distance from the ground to the center of gravity of the completed vehicle [mm (in)].
CG_{vb}	Vertical distance from the ground to the center of gravity of the SUB and/or permanently attached equipment [mm (in)].
CG_{vc}	Vertical distance from the ground to the center of gravity of the chassis (including cab) [mm (in)].
CG_{vl}	Vertical distance from the ground to the center of gravity of the cargo [mm (in)].
CG_{vp}	Vertical distance from the ground to the center of gravity of the passenger load [1,017 mm (40 in)].
GVW	Actual Gross Vehicle Weight (pounds). $GVW = W_b + W_c + W_l + P$
GVWR	Gross Vehicle Weight Rating of the vehicle [kg (lbs)].
h_f	Vertical distance between the front wheel center to ground line.
h_R	Vertical distance between the rear wheel center to ground line.
P	Two passenger load 136 kg (300 lbs).

Term	Definition
P_f	Passenger front load distribution [kg (lbs)]. $P_f = P - P_r$
P_r	Passenger rear load distribution kg (lbs). $P_r = \frac{P \times CG_{hp}}{WB}$
SUB	A Second Unit Body (SUB) consists of the body structure and/or all the cargo carrying, work performing and/or load bearing components and/or equipment installed by a subsequent stage manufacturer.
W_b	Weight of the SUB and/or permanently attached added equipment [kg (lbs)].
WB	Vehicle wheelbase [mm (in)].
W_c	Weight of the vehicle (chassis and cab with fuel tank full), including options weight [kg (lbs)].
W_F	Weight at the front wheels of the vehicle (chassis and cab with fuel tank full), including options weight at raised position [kg (lbs)].
W_{FO}	Weight at the front wheels of the vehicle (chassis and cab with fuel tank full), including options weight at horizontal position [kg (lbs)].
W_I	Weight of the cargo [kg (lbs)].
W_p	Weight of one passenger 68 kg (150 lbs)
W_R	Weight at the rear wheels of the vehicle (chassis and cab with fuel tank full), including options weight at raised position [kg (lbs)].
W_{rb}	Weight at the rear wheels of the SUB and/or permanently attached added equipment [kg (lbs)].
W_{rI}	Weight at the cargo on the rear wheels [kg (lbs)].
W_{RO}	Weight at the rear wheels of the vehicle (chassis and cab with fuel tank full), including options weight at horizontal position [kg (lbs)].

This information is being used to assist upfitters in determining the vehicle center of gravity height. This has been prepared for the use of knowledgeable test engineers. It is not a how-to document for people without technical training.

Recommended Procedure

Setup

The following vehicle conditions should be verified prior to the measurement:

- Vehicle Mass: Unloaded Vehicle Condition — Full fluids, spare tire, jack and tire tool.
- Vehicle Posture: Unloaded Vehicle Condition — Adjust fender opening height to design value.
- Tire: Production parts shall be used. Tire pressure should be set to the specified pressure on Tire Placard once the vehicle has cooled.
- Steering Wheel: Set to center of stroke with wheels pointing forward.
- Seats: Adjust to reference position:
 - Longitudinal slide: Center of slide
 - Seat Lifter: Lowermost
 - Back angle: Set to normal driving condition or as close to 23° as possible.
- Window Glass: Fully closed.
- Other Parts: Production parts shall be used.
- Road Surface to be used: Flat load cell.
- Measurement Needed: Wheelbase, height of wheel centers from ground, lift heights, axle loads.
- Shift Position: Neutral for both AT and MT vehicles. For safety, apply the parking brake.

Measurement Methods

1. The vehicle should be at its unloaded vehicle condition, with full fluids and equipped with spare tire, jack and tools.
2. Measure the wheelbase of the vehicle (WB) on the left-hand and right-hand sides of the vehicle and use the average value for the calculations. Measure the height of the 4 wheel centers from the ground to get h_f and h_r .
3. Replace the shock absorbers with turnbuckles or solid link to avoid suspension travel.
4. Increase the tire air pressure to the maximum recommended level specified in tire placard or Owner's Manual.
5. Once the vehicle is on the scale, set the parking brake to prevent vehicle from rolling.
6. Measure the Rear Wheel Load (W_{RO}) in a horizontal position.
7. Raise the front of the vehicle with a hoist. Lift height should be at 0.5 m (1.6 ft) to start, with additional lift heights used to improve accuracy. (i.e., 0.5 m (1.6 ft) + a, 0.5 m (1.6 ft) + B).
8. Measure the Rear Wheel Load (W_R) with raised vehicle.
9. Change the lift height and measure the load on the rear wheel to find the relationship between lift and load. Measure two times for each lift height.
10. Follow the same procedure from (7) to (9) by raising the rear wheels.

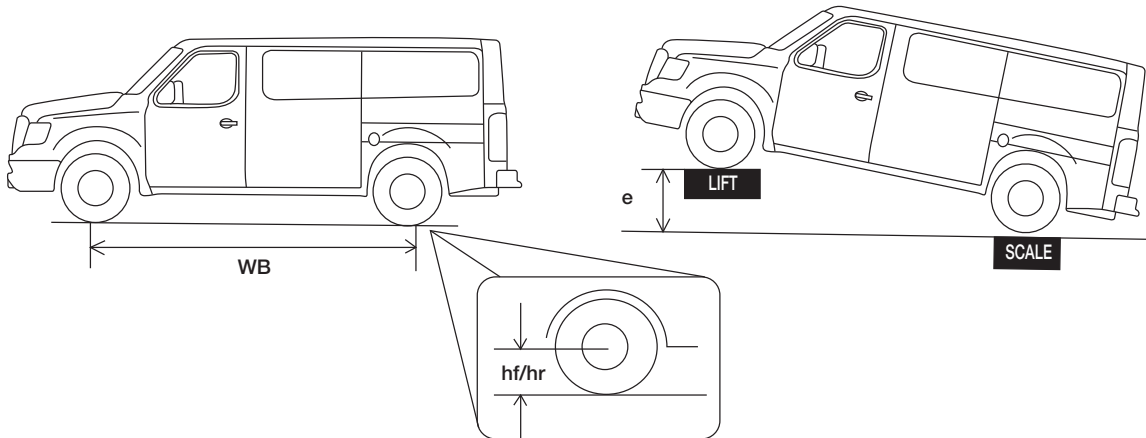

AAZIA0368GB

Analysis Method

1. Plot the relation between the lift height (e) and the load on rear wheels (W_{RO}) for raising the front wheels and the relation between the lift (e) and the load on the front wheels (W_{FO}) for raising the rear wheels. Draw a regression line for both cases with front or rear.
2. Obtain the shifted load (ΔW_{RO} and ΔW_{FO}) for the lift (e) according to the graph. ΔW_{RO} and ΔW_{FO} with e = 0.5 m (1.6 ft.) shall be representative value.
3. Calculate the CG height by using the following equations:

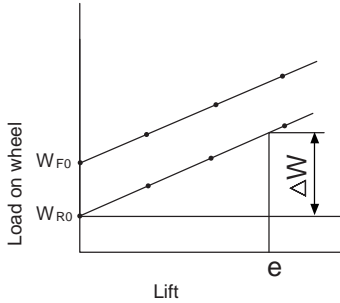

Front wheels raised

$$CG_v = \frac{\Delta W}{W} WB \frac{\sqrt{WB^2 - e^2}}{e} + h_f + \frac{W_{RO}}{W} (h_R - h_f)$$

Rear wheels raised

$$CG_v = \frac{\Delta W}{W} WB \frac{\sqrt{WB^2 - e^2}}{e} + h_R + \frac{W_{FO}}{W} (h_f - h_R)$$

Where,

- CG_v: Height of gravity center m (ft)
- W: Vehicle weight (W=W_{FO}+W_{RO}) kg (lbs)
- W_{FO}: Front wheel load (in horizontal position) kg (lbs)
- W_{RO}: Rear wheel load (in horizontal position) kg (lbs)
- e: Lift m (ft)
- ΔW: shifted load kg (lbs)
- WB: Wheelbase m (ft)
- h_f: Front wheel center height m (ft)
- h_R: Rear wheel center height m (ft)

AAZIA0369GB

Results

The center of gravity height (CG_v) obtained is theoretically the same for both cases with the front or rear wheels raised. The accuracy of the results should be verified by performing several tests and averaging the results.

Vehicle Center of Gravity Envelope – Unloaded Vehicle Weight (UVW)

The diagrams below show the vehicle center of gravity envelope for standard roof and high roof body styles.

The center of gravity zone (CG zone) shall not be exceeded by any upfitter package.

Standard Roof

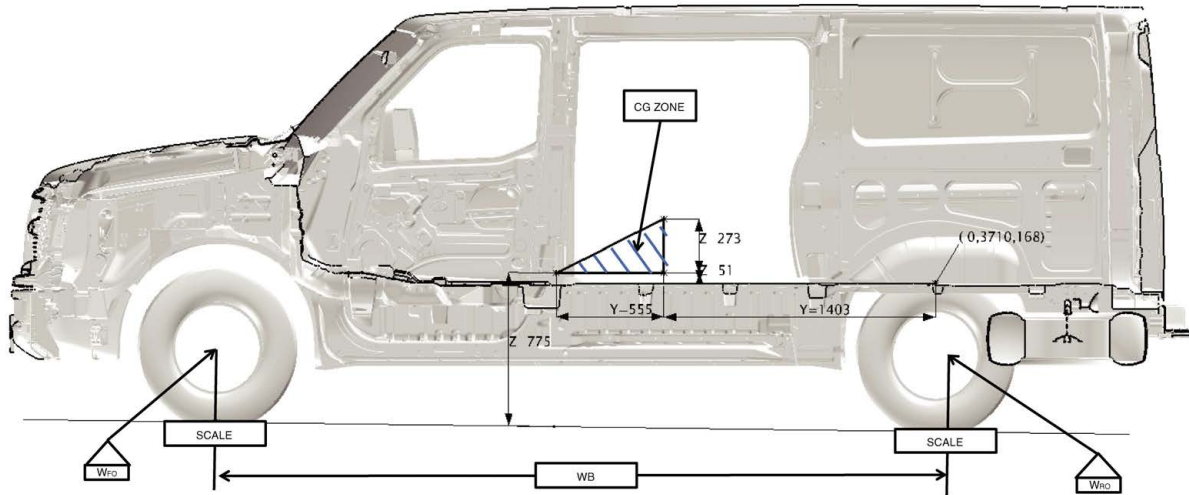

AAZIA0370GB

High Roof

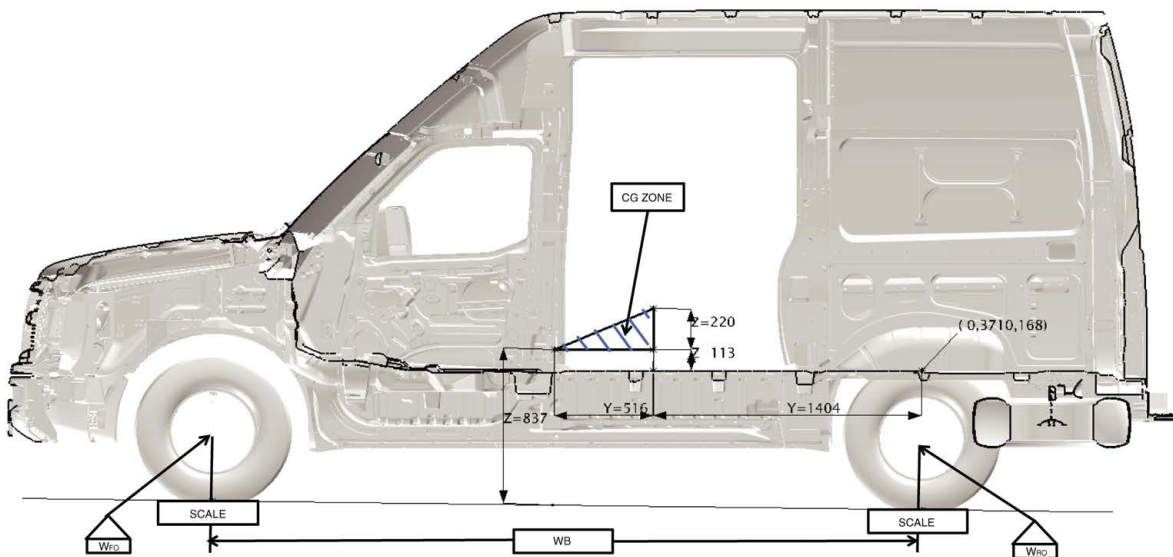

AAZIA0371GB

CENTER OF GRAVITY (CG)

[SAFETY INFORMATION]

Type		Cargo Van						
Class		1500	2500				3500	
Roof		Standard Roof	Standard Roof	High Roof		Standard Roof	High Roof	
Engine		V6 Engine	V6 Engine	V8 Engine	V8 Engine	V8 Engine	V8 Engine	
CG Height	CW*	771.2 mm (30.36 in)	768.4 mm (30.25 in)	760.0 mm (29.92 in)	815.8 mm (32.12 in)	813.3 mm (32.02 in)	784.5 mm (30.89 in)	831.4 mm (32.73 in)
	F1**	778.7 mm (30.66 in)	776.4 mm (30.57 in)	774.4 mm (30.49 in)	822.5 mm (32.38 in)	819.9 mm (32.28 in)	792.5 mm (31.20 in)	838.1 mm (33.00 in)

* CW=Curb Weight

** F1=With Driver

Maximum Unloaded Vehicle Weight (UVW) – Component Identification

NOTE:

The shaded components shown in the illustration are present on vehicles built 08/2014 or later. Vehicles built up to 07/2014 will not have these components. To confirm vehicle build date, check the certification label located on the left-hand B-pillar. Refer to [LABEL INFORMATION \(pg. 60\)](#).

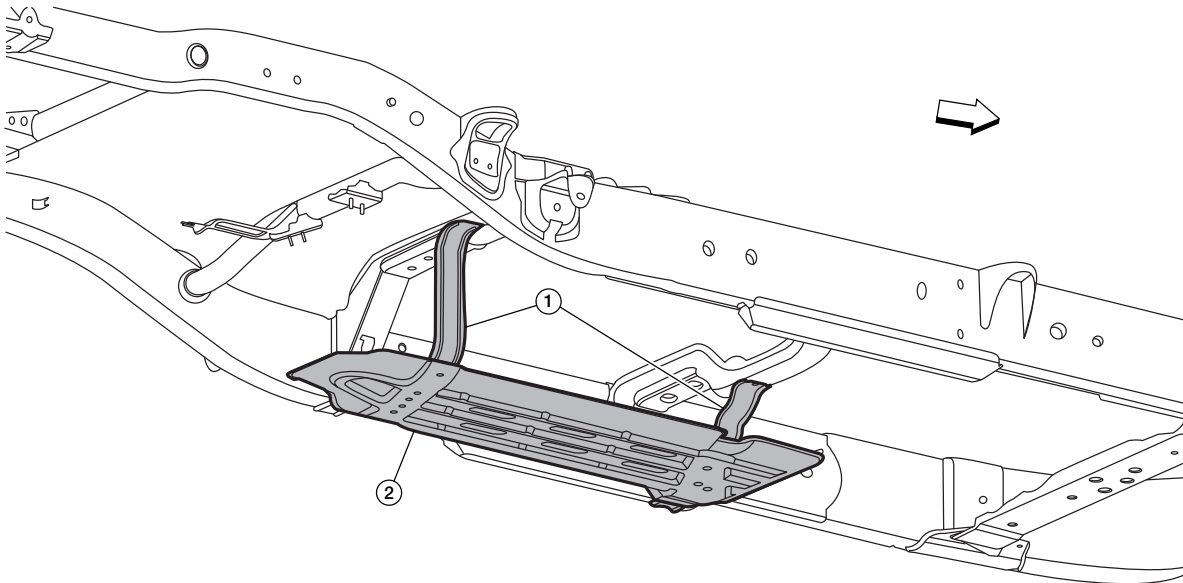

AAZIA0457ZZ

NOTE:

Underside view shown (vehicles built 08/2014 or later only).

↔: Front of vehicle.

1. Frame brackets (Qty.= 2)

2. Fuel tank protector (Qty.= 1)

40 Maximum Unloaded Vehicle Weight (UVW) Resource Chart

The maximum UVW / ARC values are shown below.

NOTE:
 Please, confirm vehicle build date before referring to information below. Vehicles built 08/2014 or later can be identified using the component illustrations in Maximum Unloaded Vehicle Weight (UVW) – Component Identification, earlier in this section. For those vehicles, refer to Chart B. Vehicles built 07/2014 or earlier are not equipped with the components shown in the illustrations. For those vehicles, refer to Chart A. For 2015 and later model year vehicles, refer to the appropriate model year chart following.

Chart A: Cargo Van – Vehicles Built 07/2014 or Earlier													
Model (*1)				Max UVW Kg (lbs)	Max GVWR Kg (lbs)	UVW Payload Kg (lbs) (*2)	Max ARC Kg (lbs) (*3)	Max Cargo Kg (lbs) (*4)	Max GAWR Kg (lbs)		Base Curb Weight Kg (lbs)		
NV Class	Engine	Roof Style	Model Grade						Front	Rear	Front	Rear	Total
1500	V6	Std Roof	S	2,763 (6,091)	3,878 (8,550)	1,175 (2,590)	136 (300)	Refer to "Max C"	1,735 (3,825)	2,665 (5,875)	1,383 (3,049)	1,244 (2,743)	2,627 (5,791)
	V6	Std Roof	SV	2,763 (6,091)	3,878 (8,550)	1,100 (2,425)	102 (225)		1,735 (3,825)	2,665 (5,875)	1,389 (3,062)	1,272 (2,804)	2,661 (5,866)
2500	V6	Std Roof	S	3,013 (6,642)	4,128 (9,100)	1,425 (3,141)	378 (833)		1,735 (3,825)	2,665 (5,875)	1,390 (3,064)	1,246 (2,747)	2,636 (5,811)
	V6	Std Roof	SV	3,013 (6,642)	4,128 (9,100)	1,350 (2,976)	330 (728)		1,735 (3,825)	2,665 (5,875)	1,399 (3,084)	1,284 (2,831)	2,683 (5,915)
	V6	High Roof	S	3,013 (6,642)	4,128 (9,100)	1,350 (2,976)	304 (670)		1,735 (3,825)	2,665 (5,875)	1,406 (3,100)	1,304 (2,875)	2,710 (5,974)
	V6	High Roof	SV	3,013 (6,642)	4,128 (9,100)	1,275 (2,810)	255 (562)		1,735 (3,825)	2,665 (5,875)	1,416 (3,122)	1,342 (2,959)	2,758 (6,080)
	V8	Std Roof	S	3,013 (6,642)	4,128 (9,100)	1,375 (3,031)	349 (769)		1,735 (3,825)	2,665 (5,875)	1,421 (3,133)	1,243 (2,740)	2,664 (5,873)
	V8	Std Roof	SV	3,013 (6,642)	4,128 (9,100)	1,300 (2,866)	301 (664)		1,735 (3,825)	2,665 (5,875)	1,431 (3,155)	1,282 (2,826)	2,713 (5,981)
	V8	High Roof	S	3,013 (6,642)	4,128 (9,100)	1,300 (2,866)	271 (597)		1,735 (3,825)	2,665 (5,875)	1,434 (3,161)	1,308 (2,884)	2,742 (6,045)
	V8	High Roof	SV	3,013 (6,642)	4,128 (9,100)	1,225 (2,700)	248 (547)		1,735 (3,825)	2,665 (5,875)	1,441 (3,177)	1,325 (2,921)	2,766 (6,098)

Chart A: Cargo Van – Vehicles Built 07/2014 or Earlier													
Model (*1)				Max UVW Kg (lbs)	Max GVWR Kg (lbs)	UVW Payload Kg (lbs) (*2)	Max ARC Kg (lbs) (*3)	Max Cargo Kg (lbs) (*4)	Max GAWR Kg (lbs)		Base Curb Weight Kg (lbs)		
NV Class	Engine	Roof Style	Model Grade						Front	Rear	Front	Rear	Total
3500	V8	Std Roof	S	3,376 (7,443)	4,491 (9,900)	1,750 (3,858)	710 (1,565)	Refer to "Max C"	1,735 (3,825)	2,665 (5,875)	1,422 (3,135)	1,244 (2,743)	2,666 (5,877)
	V8	Std Roof	SV	3,376 (7,443)	4,491 (9,900)	1,675 (3,692)	662 (1,459)		1,735 (3,825)	2,665 (5,875)	1,432 (3,157)	1,283 (2,829)	2,715 (5,985)
	V8	High Roof	S	3,376 (7,443)	4,491 (9,900)	1,675 (3,692)	632 (1,393)		1,735 (3,825)	2,665 (5,875)	1,435 (3,164)	1,309 (2,886)	2,744 (6,049)
	V8	High Roof	SV	3,376 (7,443)	4,491 (9,900)	1,600 (3,527)	609 (1,343)		1,735 (3,825)	2,665 (5,875)	1,442 (3,179)	1,326 (2,923)	2,768 (6,102)

*1: Wheelbase for all models is 3,710 mm (146 in).

*2: Load rating representing maximum allowable weight of people, cargo and aftermarket equipment and is reduced by optional equipment weight.

*3: ARC aftermarket equipment Accessory Reserve Capacity for models with standard equipment.

*4: When an ARC is installed, the Max Cargo capacity must be considered by the calculation for Max C.

Chart B: Cargo Van — 2014 Model Year Late Build (after 08/2014)

Model (*1)				Max UVW Kg (lbs)	Max GVWR Kg (lbs)	UVW Payload Kg (lbs) (*2)	Max ARC Kg (lbs) (*3)	Max Cargo Kg (lbs) (*4)	Max GAWR Kg (lbs)		Base Curb Weight Kg (lbs)		
NV Class	Engine	Roof Style	Model Grade						Front	Rear	Front	Rear	Total
1500	V6	Std Roof	S	3,236 (7,134)	3,878 (8,550)	1,175 (2,590)	602 (1,327)	Refer to "Max C"	1,735 (3,825)	2,665 (5,875)	1,386 (3,056)	1,249 (2,754)	2,635 (5,809)
	V6	Std Roof	SV	3,236 (7,134)	3,878 (8,550)	1,100 (2,425)	567 (1,250)		1,735 (3,825)	2,665 (5,875)	1,392 (3,069)	1,277 (2,815)	2,669 (5,884)
2500	V6	Std Roof	S	3,486 (7,685)	4,128 (9,100)	1,425 (3,141)	843 (1,858)		1,735 (3,825)	2,665 (5,875)	1,392 (3,069)	1,251 (2,758)	2,643 (5,827)
	V6	Std Roof	SV	3,486 (7,685)	4,128 (9,100)	1,350 (2,976)	795 (1,753)		1,735 (3,825)	2,665 (5,875)	1,402 (3,091)	1,289 (2,842)	2,691 (5,933)
	V6	High Roof	S	3,486 (7,685)	4,128 (9,100)	1,350 (2,976)	769 (1,695)		1,735 (3,825)	2,665 (5,875)	1,408 (3,104)	1,309 (2,886)	2,717 (5,990)
	V6	High Roof	SV	3,486 (7,685)	4,128 (9,100)	1,275 (2,810)	721 (1,590)		1,735 (3,825)	2,665 (5,875)	1,418 (3,126)	1,347 (2,970)	2,765 (6,096)
	V8	Std Roof	S	3,486 (7,685)	4,128 (9,100)	1,375 (3,031)	814 (1,795)		1,735 (3,825)	2,665 (5,875)	1,424 (3,139)	1,248 (2,751)	2,672 (5,891)
	V8	Std Roof	SV	3,486 (7,685)	4,128 (9,100)	1,300 (2,866)	766 (1,689)		1,735 (3,825)	2,665 (5,875)	1,434 (3,161)	1,286 (2,835)	2,720 (5,997)
	V8	High Roof	S	3,486 (7,685)	4,128 (9,100)	1,300 (2,866)	736 (1,623)		1,735 (3,825)	2,665 (5,875)	1,437 (3,168)	1,313 (2,895)	2,750 (6,063)
	V8	High Roof	SV	3,486 (7,685)	4,128 (9,100)	1,225 (2,700)	713 (1,572)		1,735 (3,825)	2,665 (5,875)	1,444 (3,183)	1,330 (2,932)	2,774 (6,116)
3500	V8	Std Roof	S	3,849 (8,586)	4,491 (9,900)	1,750 (3,858)	1,175 (2,590)	1,735 (3,825)	2,665 (5,875)	1,425 (3,142)	1,249 (2,754)	2,674 (5,895)	
	V8	Std Roof	SV	3,849 (8,586)	4,491 (9,900)	1,675 (3,692)	1,127 (2,485)	1,735 (3,825)	2,665 (5,875)	1,435 (3,164)	1,287 (2,837)	2,722 (6,001)	
	V8	High Roof	S	3,849 (8,586)	4,491 (9,900)	1,675 (3,692)	1,097 (2,418)	1,735 (3,825)	2,665 (5,875)	1,438 (3,170)	1,314 (2,897)	2,752 (6,067)	
	V8	High Roof	SV	3,849 (8,586)	4,491 (9,900)	1,600 (3,527)	1,074 (2,368)	1,735 (3,825)	2,665 (5,875)	1,445 (3,186)	1,331 (2,934)	2,776 (6,120)	

CENTER OF GRAVITY (CG)

[SAFETY INFORMATION]

*1: Wheelbase for all models is 3,710 mm (146 in).

*2: Load rating representing maximum allowable weight of people, cargo and aftermarket equipment and is reduced by optional equipment weight.

*3: ARC aftermarket equipment Accessory Reserve Capacity for models with standard equipment.

*4: When an ARC is installed, the Max Cargo capacity must be considered by the calculation for Max C.

Chart C: Cargo Van — 2015-2016 Model Years

Model (*1)				Max UVW Kg (lbs)	Max GVWR Kg (lbs)	UVW Payload Kg (lbs) (*2)	Max ARC Kg (lbs) (*3)	Max Cargo Kg (lbs) (*4)	Max GAWR Kg (lbs)		Base Curb Weight Kg (lbs)		
NV Class	Engine	Roof Style	Model Grade						Front	Rear	Front	Rear	Total
1500	V6	Std Roof	S	3,236 (7,134)	3,878 (8,550)	1,175 (2,590)	584 (1,288)	Refer to "Max C"	1,735 (3,825)	2,665 (5,875)	1,397 (3,080)	1,255 (2,767)	2,652 (5,847)
	V6	Std Roof	SV	3,236 (7,134)	3,878 (8,550)	1,100 (2,425)	548 (1,288)		1,735 (3,825)	2,665 (5,875)	1,403 (3,093)	1,286 (2,835)	2,689 (5,928)
2500	V6	Std Roof	S	3,486 (7,685)	4,128 (9,100)	1,425 (3,141)	843 (1,858)		1,735 (3,825)	2,665 (5,875)	1,392 (3,069)	1,251 (2,758)	2,643 (5,827)
	V6	Std Roof	SV	3,486 (7,685)	4,128 (9,100)	1,350 (2,976)	782 (1,724)		1,735 (3,825)	2,665 (5,875)	1,410 (3,108)	1,294 (2,853)	2,704 (5,961)
	V6	Std Roof	SL	3,486 (7,685)	4,128 (9,100)	1,350 (2,976)	778 (1,715)		1,735 (3,825)	2,665 (5,875)	1,413 (3,115)	1,295 (2,855)	2,708 (5,970)
	V6	High Roof	S	3,486 (7,685)	4,128 (9,100)	1,350 (2,976)	769 (1,695)		1,735 (3,825)	2,665 (5,875)	1,408 (3,104)	1,309 (2,886)	2,717 (5,990)
	V6	High Roof	SV	3,486 (7,685)	4,128 (9,100)	1,275 (2,810)	708 (1,561)		1,735 (3,825)	2,665 (5,875)	1,426 (3,144)	1,352 (2,981)	2,778 (6,124)
	V6	High Roof	SL	3,486 (7,685)	4,128 (9,100)	1,275 (2,810)	704 (1,552)		1,735 (3,825)	2,665 (5,875)	1,429 (3,150)	1,353 (2,983)	2,782 (6,133)
	V8	Std Roof	S	3,486 (7,685)	4,128 (9,100)	1,375 (3,031)	814 (1,795)		1,735 (3,825)	2,665 (5,875)	1,423 (3,137)	1,249 (2,754)	2,672 (5,891)
	V8	Std Roof	SV	3,486 (7,685)	4,128 (9,100)	1,300 (2,866)	753 (1,660)		1,735 (3,825)	2,665 (5,875)	1,441 (3,177)	1,291 (2,848)	2,733 (6,025)
	V8	Std Roof	SL	3,486 (7,685)	4,128 (9,100)	1,300 (2,866)	749 (1,650)		1,735 (3,825)	2,665 (5,875)	1,444 (3,183)	1,293 (2,851)	2,737 (6,034)
	V8	High Roof	S	3,486 (7,685)	4,128 (9,100)	1,300 (2,866)	736 (1,623)		1,735 (3,825)	2,665 (5,875)	1,437 (3,168)	1,313 (2,895)	2,750 (6,063)
V8	High Roof	SV	3,486 (7,685)	4,128 (9,100)	1,225 (2,700)	675 (1,488)	1,735 (3,825)	2,665 (5,875)	1,455 (3,208)	1,356 (2,989)	2,811 (6,197)		
V8	High Roof	SL	3,486 (7,685)	4,128 (9,100)	1,225 (2,700)	671 (1,480)	1,735 (3,825)	2,665 (5,875)	1,457 (3,212)	1,358 (2,994)	2,815 (6,206)		

CENTER OF GRAVITY (CG)

[SAFETY INFORMATION]

Chart C: Cargo Van — 2015-2016 Model Years														
Model (*1)				Max UVW Kg (lbs)	Max GVWR Kg (lbs)	UVW Payload Kg (lbs) (*2)	Max ARC Kg (lbs) (*3)	Max Cargo Kg (lbs) (*4)	Max GAWR Kg (lbs)		Base Curb Weight Kg (lbs)			
NV Class	Engine	Roof Style	Model Grade						Front	Rear	Front	Rear	Total	
3500	V8	Std Roof	S	3,849 (8,586)	4,491 (9,900)	1,750 (3,858)	1,175 (2,590)	Refer to "Max C"	1,735 (3,825)	2,760 (6,086)	1,425 (3,142)	1,249 (2,754)	2,674 (5,895)	
	V8	Std Roof	SV	3,849 (8,586)	4,491 (9,900)	1,675 (3,693)	1,114 (2,456)		1,735 (3,825)	2,760 (6,086)	1,443 (3,181)	1,292 (2,848)	2,735 (6,030)	
	V8	Std Roof	SL	3,849 (8,586)	4,491 (9,900)	1,675 (3,692)	1,110 (2,456)		1,735 (3,825)	2,760 (6,086)	1,445 (3,186)	1,294 (2,853)	2,739 (6,038)	
	V8	High Roof	S	3,849 (8,586)	4,491 (9,900)	1,675 (3,692)	1,097 (2,419)		1,735 (3,825)	2,760 (6,086)	1,438 (3,170)	1,314 (2,897)	2,752 (6,070)	
	V8	High Roof	SV	3,849 (8,586)	4,491 (9,900)	1,600 (3,527)	1,036 (2,284)		1,735 (3,825)	2,760 (6,086)	1,456 (3,210)	1,357 (2,992)	2,813 (6,202)	
	V8	High Roof	SL	3,849 (8,586)	4,491 (9,900)	1,600 (3,527)	1,032 (2,276)		1,735 (3,825)	2,760 (6,086)	1,458 (3,214)	1,359 (2,996)	2,817 (6,210)	

*1: Wheelbase for all models is 3,710 mm (146 in).

*2: Load rating representing maximum allowable weight of people, cargo and aftermarket equipment and is reduced by optional equipment weight.

*3: ARC aftermarket equipment Accessory Reserve Capacity for models with standard equipment.

*4: When an ARC is installed, the Max Cargo capacity must be considered by the calculation for Max C.

Chart D: Cargo Van — 2017 Model Year

Model (*1)				Max UVW Kg (lbs)	Max GVWR Kg (lbs)	UVW Payload Kg (lbs) (*2)	Max ARC Kg (lbs) (*3)	Max Cargo Kg (lbs) (*4)	Max GAWR Kg (lbs)		Base Curb Weight Kg (lbs)		
NV Class	Engine	Roof Style	Model Grade						Front	Rear	Front	Rear	Total
1500	V6	Std Roof	S	3,236 (7,134)	3,878 (8,550)	1,175 (2,590)	603 (1,329)	Refer to "Max C"	1,735 (3,825)	2,665 (5,875)	1,387 (3,057)	1,247 (2,749)	2,633 (5,806)
	V6	Std Roof	SV	3,236 (7,134)	3,878 (8,550)	1,125 (2,480)	554 (1,221)				1,398 (3,082)	1,284 (2,831)	2,682 (5,913)
2500	V6	Std Roof	S	3,496 (7,707)	4,128 (9,100)	1,425 (3,142)	862 (1,900)		1,735 (3,825)	2,665 (5,875)	1,387 (3,057)	1,247 (2,750)	2,634 (5,807)
	V6	Std Roof	SV	3,496 (7,707)	4,128 (9,100)	1,375 (3,031)	797 (1,758)				1,406 (3,100)	1,293 (2,850)	2,699 (5,950)
	V6	Std Roof	SL	3,496 (7,707)	4,128 (9,100)	1,375 (3,031)	790 (1,743)		1,410 (3,108)	1,296 (2,856)	2,706 (5,965)		
	V6	High Roof	S	3,496 (7,707)	4,128 (9,100)	1,350 (2,976)	788 (1,736)		1,403 (3,093)	1,305 (2,878)	2,708 (5,971)		
	V6	High Roof	SV	3,496 (7,707)	4,128 (9,100)	1,300 (2,866)	723 (1,594)		1,422 (3,136)	1,351 (2,977)	2,773 (6,113)		
	V6	High Roof	SL	3,496 (7,707)	4,128 (9,100)	1,300 (2,866)	716 (1,579)		1,426 (3,144)	1,354 (2,984)	2,780 (6,128)		
	V8	Std Roof	S	3,496 (7,707)	4,128 (9,100)	1,350 (2,976)	764 (1,684)		1,449 (3,194)	1,283 (2,829)	2,732 (6,023)		
	V8	Std Roof	SV	3,496 (7,707)	4,128 (9,100)	1,300 (2,866)	700 (1,542)		1,468 (3,236)	1,328 (2,929)	2,796 (6,165)		
	V8	Std Roof	SL	3,496 (7,707)	4,128 (9,100)	1,275 (2,811)	693 (1,527)		1,472 (3,245)	1,331 (2,935)	2,803 (6,180)		
	V8	High Roof	S	3,496 (7,707)	4,128 (9,100)	1,275 (2,811)	690 (1,521)		1,459 (3,218)	1,347 (2,969)	2,806 (6,186)		
	V8	High Roof	SV	3,496 (7,707)	4,128 (9,100)	1,225 (2,701)	626 (1,379)		1,479 (3,260)	1,391 (3,068)	2,870 (6,328)		
	V8	High Roof	SL	3,496 (7,707)	4,128 (9,100)	1,200 (2,646)	619 (1,364)		1,483 (3,269)	1,394 (3,074)	2,877 (6,343)		

CENTER OF GRAVITY (CG)

[SAFETY INFORMATION]

Chart D: Cargo Van — 2017 Model Year														
Model (*1)				Max UVW Kg (lbs)	Max GVWR Kg (lbs)	UVW Payload Kg (lbs) (*2)	Max ARC Kg (lbs) (*3)	Max Cargo Kg (lbs) (*4)	Max GAWR Kg (lbs)		Base Curb Weight Kg (lbs)			
NV Class	Engine	Roof Style	Model Grade						Front	Rear	Front	Rear	Total	
3500	V8	Std Roof	S	3,849 (8,486)	4,491 (9,900)	1,700 (3,748)	1,113 (2,455)	Refer to "Max C"	1,735 (3,825)	2,760 (6,085)	1,451 (3,198)	1,285 (2,833)	2,736 (6,031)	
	V8	Std Roof	SV	3,849 (8,486)	4,491 (9,900)	1,650 (3,638)	1,049 (2,312)				1,470 (3,240)	1,330 (2,933)	2,800 (6,173)	
	V8	Std Roof	SL	3,849 (8,486)	4,491 (9,900)	1,650 (3,638)	1,042 (2,297)				1,474 (3,249)	1,333 (2,939)	2,807 (6,188)	
	V8	High Roof	S	3,849 (8,486)	4,491 (9,900)	1,625 (3,583)	1,040 (2,292)				1,461 (3,222)	1,348 (2,972)	2,809 (6,194)	
	V8	High Roof	SV	3,849 (8,486)	4,491 (9,900)	1,575 (3,472)	975 (2,150)				1,481 (3,264)	1,393 (3,072)	2,874 (6,336)	
	V8	High Roof	SL	3,849 (8,486)	4,491 (9,900)	1,575 (3,472)	968 (2,135)				1,485 (3,273)	1,396 (3,078)	2,881 (6,351)	

*1: Wheelbase for all models is 3,710 mm (146 in).

*2: Load rating representing maximum allowable weight of people, cargo and aftermarket equipment and is reduced by optional equipment weight.

*3: ARC aftermarket equipment Accessory Reserve Capacity for models with standard equipment.

*4: When an ARC is installed, the Max Cargo capacity must be considered by the calculation for Max C.

Chart E: Cargo Van — 2018 Model Year

Model (*1)				Max UVW Kg (lbs)	Max GVWR Kg (lbs)	UVW Payload Kg (lbs) (*2)	Max ARC Kg (lbs) (*3)	Max Cargo Kg (lbs) (*4)	Max GAWR Kg (lbs)		Base Curb Weight Kg (lbs)		
NV Class	Engine	Roof Style	Model Grade						Front	Rear	Front	Rear	Total
1500	V6	Std Roof	S	3,236 (7,134)	3,878 (8,550)	1,175 (2,590)	603 (1,329)	Refer to "Max C"	1,735 (3,825)	2,665 (5,875)	1,390.2 (3,064.8)	1,248.4 (2,752.2)	2,638.5 (5,817.0)
	V6	Std Roof	SV	3,236 (7,134)	3,878 (8,550)	1,125 (2,480)	554 (1,221)				1,400.7 (3,088.0)	1,284.7 (2,832.2)	2,685.3 (5,920.1)
2500	V6	Std Roof	S	3,496 (7,707)	4,128 (9,100)	1,425 (3,142)	862 (1,900)		1,735 (3,825)	2,665 (5,875)	1,390.3 (3,065.0)	1,249.0 (2,753.5)	2,639.2 (5,818.5)
	V6	Std Roof	SV	3,496 (7,707)	4,128 (9,100)	1,375 (3,031)	797 (1,758)				1,408.8 (3,105.8)	1,293.1 (2,850.7)	2,701.8 (5,956.5)
	V6	Std Roof	SL	3,496 (7,707)	4,128 (9,100)	1,375 (3,031)	790 (1,743)				1,412.6 (3,114.2)	1,295.8 (2,856.7)	2,708.3 (5,970.8)
	V6	High Roof	S	3,496 (7,707)	4,128 (9,100)	1,350 (2,976)	788 (1,736)				1,406.5 (3,100.9)	1,306.9 (2,881.2)	2,713.4 (5,982.1)
	V6	High Roof	SV	3,496 (7,707)	4,128 (9,100)	1,300 (2,866)	723 (1,594)				1,425.0 (3,141.7)	1,351.0 (2,978.4)	2,776.0 (6,120.1)
	V6	High Roof	SL	3,496 (7,707)	4,128 (9,100)	1,300 (2,866)	716 (1,579)				1,428.8 (3,150.1)	1,353.7 (2,984.3)	2,782.5 (6,134.4)
	V8	Std Roof	S	3,496 (7,707)	4,128 (9,100)	1,350 (2,976)	764 (1,684)				1,452.2 (3,201.5)	1,284.8 (2,832.5)	2,737.0 (6,033.9)
	V8	Std Roof	SV	3,496 (7,707)	4,128 (9,100)	1,300 (2,866)	700 (1,542)				1,470.7 (3,242.2)	1,328.9 (2,929.7)	2,799.6 (6,172.0)
	V8	Std Roof	SL	3,496 (7,707)	4,128 (9,100)	1,275 (2,811)	693 (1,527)				1,474.4 (3,250.4)	1,331.6 (2,935.7)	2,806.0 (6,186.1)
	V8	High Roof	S	3,496 (7,707)	4,128 (9,100)	1,275 (2,811)	690 (1,521)				1,462.9 (3,225.1)	1,348.1 (2,972.0)	2,811.0 (6,197.1)
V8	High Roof	SV	3,496 (7,707)	4,128 (9,100)	1,225 (2,701)	626 (1,379)	1,481.5 (3,266.1)	1,391.9 (3,068.6)	2,873.4 (6,334.7)				
V8	High Roof	SL	3,496 (7,707)	4,128 (9,100)	1,200 (2,646)	619 (1,364)	1,485.2 (3,274.2)	1,394.6 (3,074.5)	2,879.8 (6,348.8)				

CENTER OF GRAVITY (CG)

[SAFETY INFORMATION]

Chart E: Cargo Van — 2018 Model Year														
Model (*1)				Max UVW Kg (lbs)	Max GVWR Kg (lbs)	UVW Payload Kg (lbs) (*2)	Max ARC Kg (lbs) (*3)	Max Cargo Kg (lbs) (*4)	Max GAWR Kg (lbs)		Base Curb Weight Kg (lbs)			
NV Class	Engine	Roof Style	Model Grade						Front	Rear	Front	Rear	Total	
3500	V8	Std Roof	S	3,849 (8,486)	4,491 (9,900)	1,700 (3,748)	1,113 (2,455)	Refer to "Max C"	1,735 (3,825)	2,760 (6,085)	1,454.0 (3,205.4)	1,286.6 (2,836.5)	2,740.6 (6,041.9)	
	V8	Std Roof	SV	3,849 (8,486)	4,491 (9,900)	1,650 (3,638)	1,049 (2,312)				1,472.5 (3,246.2)	1,330.7 (2,933.7)	2,803.2 (6,179.9)	
	V8	Std Roof	SL	3,849 (8,486)	4,491 (9,900)	1,650 (3,638)	1,042 (2,297)				1,476.2 (3,254.4)	1,333.4 (2,939.6)	2,809.6 (6,194.0)	
	V8	High Roof	S	3,849 (8,486)	4,491 (9,900)	1,625 (3,583)	1,040 (2,292)				1,464.8 (3,229.2)	1,349.6 (2,975.3)	2,814.4 (6,204.6)	
	V8	High Roof	SV	3,849 (8,486)	4,491 (9,900)	1,575 (3,472)	975 (2,150)				1,483.3 (3,270.0)	1,393.7 (3,072.6)	2,877.0 (6,342.6)	
	V8	High Roof	SL	3,849 (8,486)	4,491 (9,900)	1,575 (3,472)	968 (2,135)				1,487.0 (3,278.2)	1,396.4 (3,078.5)	2,883.4 (6,356.7)	

*1: Wheelbase for all models is 3,710 mm (146 in).

*2: Load rating representing maximum allowable weight of people, cargo and aftermarket equipment and is reduced by optional equipment weight.

*3: ARC aftermarket equipment Accessory Reserve Capacity for models with standard equipment.

*4: When an ARC is installed, the Max Cargo capacity must be considered by the calculation for Max C.

Chart F: Cargo Van — 2019 Model Year

Model (*1)				Max UVW Kg (lbs)	Max GVWR Kg (lbs)	UVW Payload Kg (lbs) (*2)	Max ARC Kg (lbs) (*3)	Max Cargo Kg (lbs) (*4)	Max GAWR Kg (lbs)		Base Curb Weight Kg (lbs)		
NV Class	Engine	Roof Style	Model Grade						Front	Rear	Front	Rear	Total
1500	V6	Std Roof	S	3,236 (7,134)	3,878 (8,550)	1,175 (2,590)	603 (1,329)	Refer to "Max C"	1,735 (3,825)	2,665 (5,875)	1,390.2 (3,064.8)	1,248.4 (2,752.2)	2,638.6 (5,817.0)
	V6	Std Roof	SV	3,236 (7,134)	3,878 (8,550)	1,125 (2,480)	554 (1,221)				1,400.7 (3,088.0)	1,284.7 (2,832.2)	2,685.4 (5,920.2)
2500	V6	Std Roof	S	3,496 (7,707)	4,128 (9,100)	1,425 (3,142)	862 (1,900)		1,735 (3,825)	2,665 (5,875)	1,390.3 (3,065.1)	1,249.0 (2,753.5)	2,639.3 (5,818.6)
	V6	Std Roof	SV	3,496 (7,707)	4,128 (9,100)	1,375 (3,031)	797 (1,758)				1,408.8 (3,105.8)	1,293.1 (2,850.7)	2,701.9 (5,956.6)
	V6	Std Roof	SL	3,496 (7,707)	4,128 (9,100)	1,375 (3,031)	790 (1,743)				1,412.6 (3,114.2)	1,295.8 (2,856.7)	2,708.4 (5,970.9)
	V6	High Roof	S	3,496 (7,707)	4,128 (9,100)	1,350 (2,976)	788 (1,736)				1,406.6 (3,100.9)	1,306.9 (2,881.2)	2,713.5 (5,982.1)
	V6	High Roof	SV	3,496 (7,707)	4,128 (9,100)	1,300 (2,866)	723 (1,594)				1,425.1 (3,141.7)	1,351.0 (2,978.4)	2,776.1 (6,120.1)
	V6	High Roof	SL	3,496 (7,707)	4,128 (9,100)	1,300 (2,866)	716 (1,579)				1,428.9 (3,150.1)	1,353.7 (2,984.3)	2,782.6 (6,134.5)
	V8	Std Roof	S	3,496 (7,707)	4,128 (9,100)	1,350 (2,976)	764 (1,684)				1,452.2 (3,201.5)	1,284.8 (2,832.5)	2,737.0 (6,034.0)
	V8	Std Roof	SV	3,496 (7,707)	4,128 (9,100)	1,300 (2,866)	700 (1,542)				1,470.7 (3,242.3)	1,328.9 (2,929.7)	2,799.6 (6,172.0)
	V8	Std Roof	SL	3,496 (7,707)	4,128 (9,100)	1,275 (2,811)	693 (1,527)				1,474.4 (3,250.4)	1,331.6 (2,935.7)	2,806.0 (6,186.1)
	V8	High Roof	S	3,496 (7,707)	4,128 (9,100)	1,275 (2,811)	690 (1,521)				1,462.9 (3,225.1)	1,348.1 (2,972.1)	2,811.0 (6,197.2)
	V8	High Roof	SV	3,496 (7,707)	4,128 (9,100)	1,225 (2,701)	626 (1,379)				1,481.5 (3,266.1)	1,391.9 (3,068.6)	2,873.4 (6,334.7)
V8	High Roof	SL	3,496 (7,707)	4,128 (9,100)	1,200 (2,646)	619 (1,364)	1,485.2 (3,274.2)		1,394.6 (3,074.6)	2,879.8 (6,348.8)			

CENTER OF GRAVITY (CG)

[SAFETY INFORMATION]

Chart F: Cargo Van — 2019 Model Year														
Model (*1)				Max UVW Kg (lbs)	Max GVWR Kg (lbs)	UVW Payload Kg (lbs) (*2)	Max ARC Kg (lbs) (*3)	Max Cargo Kg (lbs) (*4)	Max GAWR Kg (lbs)		Base Curb Weight Kg (lbs)			
NV Class	Engine	Roof Style	Model Grade						Front	Rear	Front	Rear	Total	
3500	V8	Std Roof	S	3,849 (8,486)	4,491 (9,900)	1,700 (3,748)	1,113 (2,455)	Refer to "Max C"	1,735 (3,825)	2,760 (6,085)	1,454.0 (3,205.5)	1,286.6 (2,836.5)	2,740.6 (6,041.9)	
	V8	Std Roof	SV	3,849 (8,486)	4,491 (9,900)	1,650 (3,638)	1,049 (2,312)				1,472.5 (3,246.3)	1,330.7 (2,933.7)	2,803.2 (6,180.0)	
	V8	Std Roof	SL	3,849 (8,486)	4,491 (9,900)	1,650 (3,638)	1,042 (2,297)				1,476.2 (3,254.4)	1,333.4 (2,939.7)	2,809.6 (6,194.1)	
	V8	High Roof	S	3,849 (8,486)	4,491 (9,900)	1,625 (3,583)	1,040 (2,292)				1,464.8 (3,229.3)	1,349.6 (2,975.4)	2,814.4 (6,204.6)	
	V8	High Roof	SV	3,849 (8,486)	4,491 (9,900)	1,575 (3,472)	975 (2,150)				1,483.3 (3,270.1)	1,393.7 (3,072.6)	2,877.0 (6,342.7)	
	V8	High Roof	SL	3,849 (8,486)	4,491 (9,900)	1,575 (3,472)	968 (2,135)				1,487.0 (3,278.2)	1,396.4 (3,078.6)	2,883.4 (6,356.8)	

*1: Wheelbase for all models is 3,710 mm (146 in).

*2: Load rating representing maximum allowable weight of people, cargo and aftermarket equipment and is reduced by optional equipment weight.

*3: ARC aftermarket equipment Accessory Reserve Capacity for models with standard equipment.

*4: When an ARC is installed, the Max Cargo capacity must be considered by the calculation for Max C.

Chart G: Cargo Van — 2020 Model Year														
Model (*1)					Max UVW Kg (lbs)	Max GVWR Kg (lbs)	UVW Payload Kg (lbs) (*2)	Max ARC Kg (lbs) (*3)	Max Cargo Kg (lbs) (*4)	Max GAWR Kg (lbs)		Base Curb Weight Kg (lbs)		
NV Class	Engine	Roof Style	Market	Model Grade						Front	Rear	Front	Rear	Total
1500	V6	Std Roof	USA	S	3,236 (7,134)	3,878 (8,550)	1,175 (2,590)	597 (1,317)	Refer to "Max C"	1,735 (3,825)	2,665 (5,875)	1,390.2 (3,064.8)	1,248.4 (2,752.2)	2,638.6 (5,817.0)
			CANADA					593 (1,307)				1,392.8 (3,070.6)	1,250.3 (2,756.4)	2,643.1 (5,827.0)
	V6	Std Roof	USA	SV	3,236 (7,134)	3,878 (8,550)	1,125 (2,480)	551 (1,214)				1,400.7 (3,088.0)	1,284.7 (2,832.2)	2,685.4 (5,920.2)
2500	V6	Std Roof	USA	S	3,496 (7,707)	4,128 (9,100)	1,425 (3,142)	857 (1,888)	Refer to "Max C"	1,735 (3,825)	2,665 (5,875)	1,390.3 (3,065.1)	1,249.0 (2,753.5)	2,639.3 (5,818.6)
			CANADA					831 (1,832)				1,405.1 (3,097.7)	1,259.6 (2,776.9)	2,664.7 (5,874.6)
	V6	Std Roof	USA	SV	3,496 (7,707)	4,128 (9,100)	1,375 (3,031)	794 (1,750)				1,408.8 (3,105.8)	1,293.1 (2,850.7)	2,701.9 (5,956.6)
			CANADA					746 (1,644)	1,419.1 (3,128.5)	1,331.2 (2,934.7)	2,750.3 (6,063.3)			
	V6	Std Roof	USA	SL	3,496 (7,707)	4,128 (9,100)	1,375 (3,031)	788 (1,736)	1,412.6 (3,114.2)	1,295.8 (2,856.7)	2,708.4 (5,970.9)			
	V6	High Roof	USA	S	3,496 (7,707)	4,128 (9,100)	1,350 (2,976)	783 (1,725)	Refer to "Max C"	1,735 (3,825)	2,665 (5,875)	1,406.6 (3,100.9)	1,306.9 (2,881.2)	2,713.4 (5,982.1)
			CANADA					757 (1,669)				1,421.4 (3,133.6)	1,317.5 (2,904.5)	2,738.8 (6,038.1)
	V6	High Roof	USA	SV	3,496 (7,707)	4,128 (9,100)	1,300 (2,866)	720 (1,587)				1,425.1 (3,141.7)	1,351.0 (2,978.4)	2,776.0 (6,120.1)
			CANADA					672 (1,480)	1,435.4 (3,164.4)	1,389.1 (3,062.4)	2,824.4 (6,226.8)			
	V6	High Roof	USA	SL	3,496 (7,707)	4,128 (9,100)	1,300 (2,866)	713 (1,573)	1,428.9 (3,150.1)	1,353.7 (2,984.3)	2,782.5 (6,134.4)			
	V8	Std Roof	USA	S	3,496 (7,707)	4,128 (9,100)	1,350 (2,976)	759 (1,673)	1,452.2 (3,201.5)	1,284.8 (2,832.5)	2,737.0 (6,034.0)			
			CANADA					772 (1,702)	1,462.6 (3,224.4)	1,261.3 (2,780.7)	2,723.9 (6,005.1)			

CENTER OF GRAVITY (CG)

[SAFETY INFORMATION]

Chart G: Cargo Van — 2020 Model Year														
Model (*1)					Max UVW Kg (lbs)	Max GVWR Kg (lbs)	UVW Payload Kg (lbs) (*2)	Max ARC Kg (lbs) (*3)	Max Cargo Kg (lbs) (*4)	Max GAWR Kg (lbs)		Base Curb Weight Kg (lbs)		
NV Class	Engine	Roof Style	Market	Model Grade						Front	Rear	Front	Rear	Total
2500	V8	Std Roof	USA	SV	3,496 (7,707)	4,128 (9,100)	1,300 (2,866)	696 (1,535)	Refer to "Max C"	1,735 (3,825)	2,665 (5,875)	1,470.7 (3,242.3)	1,328.9 (2,929.7)	2,799.6 (6,172.0)
			CANADA					687 (1,514)				1,476.3 (3,254.6)	1,332.9 (2,938.6)	2,809.2 (6,193.2)
	V8	Std Roof	USA	SL	3,496 (7,707)	4,128 (9,100)	1,275 (2,811)	690 (1,521)				1,474.4 (3,250.4)	1,331.6 (2,935.7)	2,806.0 (6,186.1)
	V8	High Roof	USA	S	3,496 (7,707)	4,128 (9,100)	1,275 (2,811)	685 (1,510)				1,462.9 (3,225.1)	1,348.1 (2,972.1)	2,811.0 (6,197.2)
			CANADA					699 (1,540)				1,473.1 (3,247.6)	1,324.3 (2,919.6)	2,797.4 (6,167.2)
	V8	High Roof	USA	SV	3,496 (7,707)	4,128 (9,100)	1,225 (2,701)	623 (1,372)				1,481.5 (3,266.1)	1,391.9 (3,068.6)	2,873.4 (6,334.7)
			CANADA					616 (1,375)				1,485.4 (3,274.7)	1,395.0 (3,075.5)	2,880.4 (6,350.2)
	V8	High Roof	USA	SL	3,496 (7,707)	4,128 (9,100)	1,200 (2,646)	616 (1,358)				1,485.2 (3,274.2)	1,394.6 (3,074.6)	2,879.8 (6,348.8)

CENTER OF GRAVITY (CG)

[SAFETY INFORMATION]

Chart G: Cargo Van — 2020 Model Year

Model (*1)					Max UVW Kg (lbs)	Max GVWR Kg (lbs)	UVW Payload Kg (lbs) (*2)	Max ARC Kg (lbs) (*3)	Max Cargo Kg (lbs) (*4)	Max GAWR Kg (lbs)		Base Curb Weight Kg (lbs)		
NV Class	Engine	Roof Style	Market	Model Grade						Front	Rear	Front	Rear	Total
3500	V8	Std Roof	USA	S	3,849 (8,486)	4,491 (9,900)	1,700 (3,748)	1,108 (2,444)	Refer to "Max C"	1,735 (3,825)	2,760 (6,085)	1,454.0 (3,205.5)	1,286.6 (2,836.5)	2,740.6 (6,041.9)
			CANADA					1,120 (2,471)				1,465.0 (3,229.7)	1,263.6 (2,785.8)	2,728.6 (6,015.5)
	V8	Std Roof	USA	SV	3,849 (8,486)	4,491 (9,900)	1,650 (3,638)	1,046 (2,306)				1,472.5 (3,246.3)	1,330.7 (2,933.7)	2,803.2 (6,180.0)
			CANADA					1,035 (2,282)				1,478.9 (3,260.4)	1,335.1 (2,943.4)	2,814.0 (6,203.8)
	V8	Std Roof	USA	SL	3,849 (8,486)	4,491 (9,900)	1,650 (3,638)	1,039 (2,292)				1,476.2 (3,254.4)	1,333.4 (2,939.7)	2,809.6 (6,194.1)
	V8	High Roof	USA	S	3,849 (8,486)	4,491 (9,900)	1,625 (3,583)	1,035 (2,281)				1,464.8 (3,229.3)	1,349.6 (2,975.4)	2,814.4 (6,204.6)
			CANADA					1,047 (2,308)				1,475.8 (3,253.5)	1,326.6 (2,924.7)	2,802.4 (6,178.2)
	V8	High Roof	USA	SV	3,849 (8,486)	4,491 (9,900)	1,575 (3,472)	972 (2,143)				1,483.3 (3,270.1)	1,393.7 (3,072.6)	2,877.0 (6,342.7)
			CANADA					961 (2,120)				1,489.7 (3,284.2)	1,398.1 (3,082.3)	2,887.8 (6,366.5)
	V8	High Roof	USA	SL	3,849 (8,486)	4,491 (9,900)	1,575 (3,472)	966 (2,129)				1,487.0 (3,278.2)	1,396.4 (3,078.6)	2,883.4 (6,356.8)

*1: Wheelbase for all models is 3,710 mm (146 in).

*2: Load rating representing maximum allowable weight of people, cargo and aftermarket equipment and is reduced by optional equipment weight.

*3: ARC aftermarket equipment Accessory Reserve Capacity for models with standard equipment.

*4: When an ARC is installed, the Max Cargo capacity must be considered by the calculation for Max C.

CENTER OF GRAVITY (CG)

[SAFETY INFORMATION]

Chart H: Cargo Van — 2021 Model Year														
Model (*1)					Max UVW Kg (lbs)	Max GVWR Kg (lbs)	UVW Payload Kg (lbs) (*2)	Max ARC Kg (lbs) (*3)	Max Cargo Kg (lbs) (*4)	Max GAWR Kg (lbs)		Base Curb Weight Kg (lbs)		
NV Class	Engine	Roof Style	Market	Model Grade						Front	Rear	Front	Rear	Total
1500	V6	Std Roof	USA	S	3,236 (7,134)	3,878 (8,550)	642 (1,416)	596 (1,315)	Refer to "Max C"	1,735 (3,825)	2,665 (5,875)	1,391.2 (3,067.1)	1,248.5 (2,752.4)	2,639.7 (5,819.5)
			CANADA					592 (1,305)				1,393.8 (3,072.8)	1,250.4 (2,756.6)	2,644.2 (5,829.4)
	V6	Std Roof	USA	SV	3,236 (7,134)	3,878 (8,550)	642 (1,416)	550 (1,211)				1,401.7 (3,090.2)	1,284.8 (2,832.4)	2,686.5 (5,922.7)
2500	V6	Std Roof	USA	S	3,496 (7,707)	4,128 (9,100)	632 (1,393)	856 (1,886)	Refer to "Max C"	1,735 (3,825)	2,665 (5,875)	1,391.3 (3,067.3)	1,249.1 (2,753.7)	2,640.4 (5,821.1)
			CANADA					830 (1,830)				1,406.2 (3,100.2)	1,259.7 (2,777.1)	2,665.9 (5,877.3)
	V6	Std Roof	USA	SV	3,496 (7,707)	4,128 (9,100)	632 (1,393)	793 (1,748)				1,409.8 (3,108.1)	1,293.2 (2,851.0)	2,703.0 (5,959.1)
			CANADA					744 (1,640)	1,420.7 (3,132.1)	1,331.3 (2,935.0)	2,752.0 (6,067.1)			
	V6	High Roof	USA	S	3,496 (7,707)	4,128 (9,100)	632 (1,393)	781 (1,722)	Refer to "Max C"	1,735 (3,825)	2,665 (5,875)	1,407.6 (3,103.2)	1,307.0 (2,881.4)	2,714.6 (5,984.6)
			CANADA					756 (1,666)				1,422.5 (3,136.0)	1,317.6 (2,904.8)	2,740.1 (6,040.8)
	V6	High Roof	USA	SV	3,496 (7,707)	4,128 (9,100)	632 (1,393)	719 (1,584)				1,426.1 (3,144.0)	1,351.1 (2,978.6)	2,777.2 (6,122.6)
			CANADA					670 (1,476)	1,437.0 (3,168.0)	1,389.2 (3,062.6)	2,826.2 (6,230.6)			
	V8	Std Roof	CANADA	S	3,496 (7,707)	4,128 (9,100)	632 (1,393)	771 (1,699)	1,463.6 (3,226.7)	1,261.4 (2,780.9)	2,725.0 (6,007.6)			

CENTER OF GRAVITY (CG)

[SAFETY INFORMATION]

Chart H: Cargo Van — 2021 Model Year														
Model (*1)					Max UVW Kg (lbs)	Max GVWR Kg (lbs)	UVW Payload Kg (lbs) (*2)	Max ARC Kg (lbs) (*3)	Max Cargo Kg (lbs) (*4)	Max GAWR Kg (lbs)		Base Curb Weight Kg (lbs)		
NV Class	Engine	Roof Style	Market	Model Grade						Front	Rear	Front	Rear	Total
2500	V8	Std Roof	USA	SV	3,496 (7,707)	4,128 (9,100)	632 (1,393)	695 (1,533)	Refer to "Max C"	1,735 (3,825)	2,665 (5,875)	1,471.7 (3,244.5)	1,329.0 (2,930.0)	2,800.7 (6,174.5)
			CANADA					686 (1,511)				1,477.4 (3,257.1)	1,333.0 (2,938.8)	2,810.4 (6,195.9)
	V8	High Roof	CANADA	S	3,496 (7,707)	4,128 (9,100)	632 (1,393)	697 (1,537)				1,474.2 (3,250.1)	1,324.4 (2,919.8)	2,798.6 (6,169.9)
	V8	High Roof	USA	SV	3,496 (7,707)	4,128 (9,100)	632 (1,393)	621 (1,370)				1,482.5 (3,268.3)	1,392.0 (3,068.9)	2,874.5 (6,337.2)
			CANADA					614 (1,354)				1,486.5 (3,277.2)	1,395.1 (3,075.7)	2,881.6 (6,352.9)
	V8	Std Roof	CANADA	S	3,849 (8,486)	4,491 (9,900)	642 (1,414)	1,119 (2,468)				1,466.0 (3,232.0)	1,263.7 (2,786.0)	2,729.7 (6,018.0)
3500	V8	Std Roof	USA	SV	3,849 (8,486)	4,491 (9,900)	642 (1,414)	1,045 (2,304)	Refer to "Max C"	1,735 (3,825)	2,760 (6,085)	1,473.5 (3,248.5)	1,330.8 (2,933.9)	2,804.3 (6,182.4)
			CANADA					1,034 (2,280)				1,480.0 (3,262.8)	1,335.2 (2,943.6)	2,815.2 (6,206.5)
	V8	Std Roof	USA	SL	3,849 (8,486)	4,491 (9,900)	642 (1,414)	1,038 (2,289)				1,477.2 (3,256.7)	1,333.5 (2,939.9)	2,810.7 (6,196.5)
	V8	High Roof	CANADA	S	3,849 (8,486)	4,491 (9,900)	642 (1,414)	1,045 (2,305)				1,476.8 (3,255.8)	1,326.7 (2,924.9)	2,803.5 (6,180.7)
	V8	High Roof	USA	SV	3,849 (8,486)	4,491 (9,900)	642 (1,414)	971 (2,141)				1,484.3 (3,272.3)	1,393.8 (3,072.8)	2,878.1 (6,345.1)
			CANADA					960 (2,117)				1,490.8 (3,286.6)	1,398.2 (3,082.5)	2,889.0 (6,369.2)
	V8	High Roof	USA	SL	3,849 (8,486)	4,491 (9,900)	642 (1,414)	964 (2,127)				1,488.0 (3,280.5)	1,396.5 (3,078.8)	2,884.5 (6,359.2)

*1: Wheelbase for all models is 3,710 mm (146 in).

*2: Load rating representing maximum allowable weight of people, cargo and aftermarket equipment and is reduced by optional equipment weight.

*3: ARC aftermarket equipment Accessory Reserve Capacity for models with standard equipment.

*4: When an ARC is installed, the Max Cargo capacity must be considered by the calculation for Max C.

The CG_{hb} can be approximated using the following formula:

$$CG_{hb} = \frac{W_{rb} \times WB}{W_b}$$

The CG_h can be approximated using the following formula:

$$CG_h = \frac{\left(W_{rb} + W_{ro} + \left(\frac{P \times CG_{hp}}{WB} \right) + W_{rl} \right) \times WB}{GVWR}$$

The Max C can be approximated using the following formula:

$$Max\ C = \frac{(FR\ GAWR - W_{FO} - P_t) \times WB}{WB - CG_{hb}}$$

After calculating Max C, GVW can be confirmed using the following formula:

$$GVW = W_c + W_b + Max\ C + P$$

If GVW is greater than GVWR, then Max C must be reduced

FMVSS/CMVSS 126 Electronic Stability Control Systems and FMVSS/CMVSS 135 Light Vehicle Brake Systems

For Body Builder’s use and applicable to FMVSS/CMVSS 126 (1) and 135 (2), the vertical vehicle center of gravity location can be approximated by following the formula below:

$$(1) CG_v = \frac{CG_{vc} W_c + CG_{vb} W_b}{W_c + W_b}$$

$$(2) CG_v = \frac{CG_{vc} W_c + CG_{vb} W_b + CG_{vp} W_p}{W_c + W_b + W_p}$$

AAZIA0183ZZ

The Vertical Center of Gravity of completed vehicle at Unloaded Vehicle Weight + 136 Kg (300 lbs) Passenger Load CG_v (Equation 1 and 2 above) must not exceed 1,016 mm (40 in), when measured from the ground.

FMVSS AND CMVSS REGULATION LIST

Standards

For FMVSS standards, refer to the following website:

www.nhtsa.gov/staticfiles/rulemaking/pdf/FMVSS-QuickRefGuide-HS811439.pdf

For CMVSS standards, refer to the following website:

www.tc.gc.ca/eng/acts-regulations/regulations-crc-c1038.htm

PRECAUTIONS

Precautions For Electrical CAN (Controller Area Network) System

- Do not modify the CAN system.
- For additional information and identification of CAN system, refer to the Service Manual or contact Nissan Commercial and Fleet Aftermarket Engineering 1 (855) 651-6655 or by E-mail at Nissan-AET@Nissan-USA.COM.

MODEL INFORMATION

LABEL INFORMATION

Identification Number

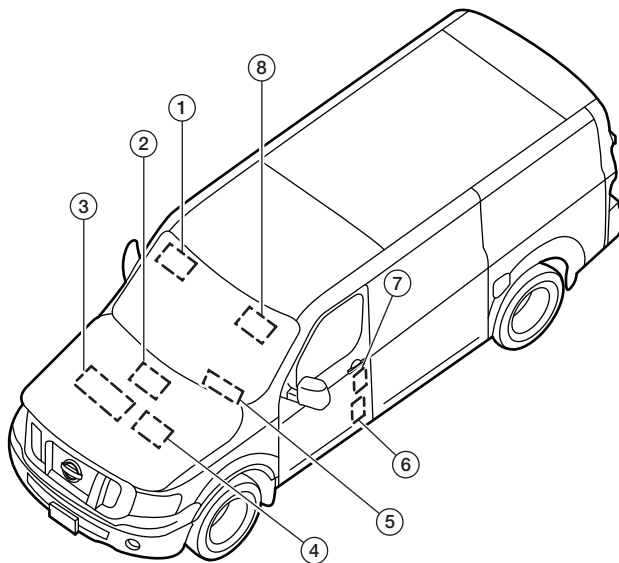

AAZIA0015ZZ

- | | | |
|---|---|---------------------------------------|
| 1. SRS air bag warning label | 2. Vehicle identification number (Chassis number) | 3. Emission control information label |
| 4. Air conditioning specification label | 5. Vehicle identification number (VIN) plate | 6. FMVSS/CMVSS Certification Label |
| 7. Tire and loading information label | 8. SRS air bag warning label | |

VEHICLE CODING INFORMATION

Vehicle Identification

Vehicle Identification Number Arrangement

Position	Character	Qualifier	Definition
1	1N6	Manufacturer	1N6: USA produced Nissan Truck
2			
3			
4	B	Engine type	A: VK56DE (5.6L) – 2012-2016 VK56VD (5.6L) – From 2017
5			B: VQ40DE (4.0L)
6	F0	Vehicle line	F0: Model Code F80
7			
7	L	Body type	L: High Roof Cargo Van
			K: Standard Roof Cargo Van
8	X	Restraint system	L: (2012-2015 Model Years) 2WD, 4-wheel ABS, Class G + Restraint System (2 Seating Capacity) (Driver and Passenger): 3-Point Manual Belts and Frontal Air Bags.
			M: 2WD, 4-wheel ABS, Class G + Restraint System (2 Seating Capacity) (Driver and Passenger): 3-Point Manual Belts, Frontal Air Bags, Side Air Bags and Curtain Side Air Bags.
			X: (2012-2015 Model Years) 2WD, 4-wheel ABS, Class H + Restraint System (2 Seating Capacity) (Driver and Passenger): 3-Point Manual Belts and Frontal Air Bags.
			Y: 2WD, 4-wheel ABS, Class H + Restraint System (2 Seating Capacity) (Driver and Passenger): 3-Point Manual Belts, Frontal Air Bags, Side Air Bags and Curtain Side Air Bags
9	*	Check digit	(0 to 9 or X) The code for the check digit is determined by a mathematical computation.

VEHICLE CODING INFORMATION

[MODEL INFORMATION]

Position	Character	Qualifier	Definition
10	C	Model year	C: 2012
	D		D: 2013
	E		E: 2014
	F		F: 2015
	G		G: 2016
	H		H: 2017
	J		J: 2018
	K		K: 2019
	L		L: 2020
	M		M: 2021
11	N	Manufacturing plant	N: Canton, Mississippi
12	XXXXXX	Vehicle serial number	Chassis number
13			
14			
15			
16			
17			

CLASS**2012–2014 Model Variation****2012–2014 Model Years**

Position	Character	Qualifier	Definition
1	Y	Body type	Y: Van Standard Roof
			Z: Van High Roof
2	PK	Engine	PK: VK56DE (5.6L)
3			LK: VQ40DE (4.0L)
4	V	Axle	V: 2WD
5	L	Drive	L: LH
6	T	Grade	Q: S
			T: SV
7	K	Transmission	K: RE5R05A (5A/T)
8	F80	Model	F80: NV Cargo
9			
10			
11	E	Intake	E: EGI
12	U	Zone	J: Mexico
			N: Canada
			U: USA
13	A	Equipment	A: NV2500
			B: NV3500
			C: NV1500
14	XXXXX	Option Codes	Option Codes
15			
16			
17			
18			

CLASS

[MODEL INFORMATION]

Body	Engine	Transmission	Destination	Grade	Equipment	Model
Standard Roof Van	VK56DE (5.6L)	RE5R05A (A/T)	USA	SV	NV2500	YPKVLTK-EUA
					NV3500	YPKVLTK-EUB
			S	NV2500	YPKVLQK-EUA	
				NV3500	YPKVLQK-EUB	
			Canada	SV	NV2500	YPKVLTK-ENA
					NV3500	YPKVLTK-ENB
	S		NV2500	YPKVLQK-ENA		
			NV3500	YPKVLQK-ENB		
	Mexico		S	NV2500	YPKVLQK-EJA	
	VQ40DE (4.0L)		USA	SV	NV2500	YLKVLTK-EUA
					NV1500	YLKVLTK-EUC
			S	NV2500	YLKVLQK-EUA	
		NV1500		YLKVLQK-EUC		
		Canada	SV	NV2500	YLKVLTK-ENA	
			NV2500	YLKVLQK-ENA		
S		NV2500	YLKVLQK-ENA			
		NV1500	YLKVLQK-ENC			
Mexico	S	NV2500	YLKVLQK-EJA			

Body	Engine	Transmission	Destination	Grade	Equipment	Model
High Roof Van	VK56DE (5.6L)	RE5R05A (A/T)	USA	SV	NV2500	ZPKVLTK-EUA
					NV3500	ZPKVLTK-EUB
			S	NV2500	ZPKVLQK-EUA	
				NV3500	ZPKVLQK-EUB	
			Canada	SV	NV2500	ZPKVLTK-ENA
					NV3500	ZPKVLTK-ENB
	S		NV2500	ZPKVLQK-ENA		
			NV3500	ZPKVLQK-ENB		
	Mexico		S	NV2500	ZPKVLQK-EJA	
	VQ40DE (4.0L)		USA	SV	NV2500	ZLKVLTK-EUA
					NV2500	ZLKVLQK-EUA
			S	NV2500	ZLKVLQK-EUA	
		NV2500		ZLKVLQK-EUA		
		Canada	SV	NV2500	ZLKVLTK-ENA	
			NV2500	ZLKVLQK-ENA		
Mexico	S	NV2500	ZLKVLQK-EJA			

2015-2016 Model Variation

2015-2016 Model Years

Position	Character	Qualifier	Definition
1	Y	Body type	Y: Van Standard Roof
			Z: Van High Roof
2	PK	Engine	PK: VK56DE (5.6L)
3			LK: VQ40DE (4.0L)
4	V	Axle	V: 2WD
5	L	Drive	L: LH
6	T	Grade	Q: S
			B: S with front seat side and front curtain air bag package
			C: S with power basic package
			D: S with front seat side and front curtain air bag package and power basic package
			E: SV with front seat side and front curtain air bag package
			F: SV with technology package (Canada)
			T: SV
			V: SL
7	K	Transmission	K: RE5R05A (5A/T)
8	F80	Model	F80: NV Cargo
9			
10			
11	E	Intake	E: EGI
12	U	Zone	J: Mexico
			N: Canada
			U: USA
13	A	Equipment	A: NV2500
			B: NV3500
			C: NV1500
14	XXXXX	Option Codes	Option Codes
15			
16			
17			
18			

CLASS

[MODEL INFORMATION]

STANDARD ROOF VAN – VQ40DE (4.0L)

Body	Engine	Transmission	Destination	Grade	Equipment	Model		
Standard Roof Van	VQ40DE (4.0L)	RE5R05A (A/T)	USA	SV SL	NV2500	YLKVLTK-EUA		
						YLKVLEK-EUA		
						YLKVLVK-EUA		
				SV	NV1500	YLKVLTK-EUC		
						YLKVLEK-EUC		
				S	NV2500	YLKVLQK-EUA		
						YLKVLBK-EUA		
						YLKVLDK-EUA		
			YLKVLCK-EUA					
			S	NV1500	YLKVLQK-EUC			
					YLKVLBK-EUC			
					YLKVLDK-EUC			
					YLKVLCK-EUC			
			Canada			SV	NV2500	YLKVLTK-ENA
								YLKVLFK-ENA
						S	NV2500	YLKVLQK-ENA
YLKVLCK-ENA								
NV1500	YLKVLQK-ENC							
	YLKVLCK-ENC							

CLASS

[MODEL INFORMATION]

STANDARD ROOF VAN – VK56DE (5.6L)

Body	Engine	Transmission	Destination	Grade	Equipment	Model
Standard Roof Van	VK56DE (5.6L)	RE5R05A (A/T)	USA	SV SL	NV2500	YPKVLTK-EUA
						YPKVLVK-EUA
						YPKVLEK-EUA
					NV3500	YPKVLTK-EUB
				YPKVLVK-EUB		
				YPKVLEK-EUB		
				S	NV2500	YPKVLQK-EUA
						YPKVLBK-EUA
			YPKVLDK-EUA			
			YPKVLCK-EUA			
			NV3500		YPKVLQK-EUB	
					YPKVLBK-EUB	
					YPKVLDK-EUB	
					YPKVLCK-EUB	
			Canada	SV	NV2500	YPKVLTK-ENA
						YPKVLFK-ENA
NV3500	YPKVLTK-ENB					
	YPKVLFK-ENB					
S	NV2500	YPKVLQK-ENA				
		YPKVLCK-ENA				
	NV3500	YPKVLQK-ENB				

HIGH ROOF VAN – VQ40DE (4.0L)

Body	Engine	Transmission	Destination	Grade	Equipment	Model
High Roof Van	VQ40DE (4.0L)	RE5R05A (A/T)	USA	SV SL	NV2500	ZLKVLTK-EUA
						ZLKVLVK-EUA
						ZLKVLEK-EUA
				S	NV2500	ZLKVLQK-EUA
						ZLKVLBK-EUA
						ZLKVLDK-EUA
			Canada	SV	NV2500	ZLKVLTK-ENA
						ZLKVLFK-ENA
				S	NV2500	ZLKVLQK-ENA
						ZLKVLCK-ENA
Mexico	S	NV2500	ZLKVLQK-EJA			

CLASS

[MODEL INFORMATION]

HIGH ROOF VAN – VK56DE (5.6L)

Body	Engine	Transmission	Destination	Grade	Equipment	Model
High Roof Van	VK56DE (5.6L)	RE5R05A (A/T)	USA	SV SL	NV2500	ZPKVLTK-EUA
						ZPKVLVK-EUA
						ZPKVLEK-EUA
				S	NV3500	ZPKVLTK-EUB
						ZPKVLVK-EUB
						ZPKVLEK-EUB
					NV2500	ZPKVLQK-EUA
						ZPKVLBK-EUA
						ZPKVLDK-EUA
			Canada	SV	NV2500	ZPKVLCK-EUA
						ZPKVLQK-EUB
						ZPKVLBK-EUB
				S	NV3500	ZPKVLDK-EUB
						ZPKVLCK-EUB
						ZPKVLTK-ENA
					NV2500	ZPKVLFK-ENA
						ZPKVLTK-ENB
						ZPKVLFK-ENB
NV2500	ZPKVLQK-ENA					
	ZPKVLCK-ENA					
	ZPKVLQK-ENB					
NV3500	ZPKVLCK-ENB					

2017 Model Variation

2017 Model Year

Position	Character	Qualifier	Definition
1	Y	Body type	Y: Van Standard Roof
			Z: Van High Roof
2	PK	Engine	PK: VK56VD (5.6L)
3			LK: VQ40DE (4.0L)
4	V	Axle	V: 2WD
5	L	Drive	L: LH
6	T	Grade	Q: S
			C: S with power basic package
			D: S with front seat side and front curtain air bag package and power basic package
			E: SV with front seat side and front curtain air bag package
			F: SV with technology package (Canada)
			T: SV
			V: SL
7	K	Transmission	K: 5 A/T S: 7 A/T
8	F80	Model	F80: NV Cargo
9			
10			
11	E	Intake	E: EGI
12	U	Zone	N: Canada
			U: USA
13	A	Equipment	A: NV2500
			B: NV3500
			C: NV1500
14	XXXXX	Option Codes	Option Codes
15			
16			
17			
18			

CLASS

[MODEL INFORMATION]

STANDARD ROOF VAN – VQ40DE (4.0L)

Body	Engine	Transmission	Destination	Grade	Equipment	Model
Standard Roof Van	VQ40DE (4.0L)	5 A/T	USA	S	NV1500	YLKVLQK-EUC
					NV2500	YLKVLCK-EUC
					NV2500	YLKVLQK-EUA
				SV	NV1500	YLKVLTK-EUC
					NV2500	YLKVLTK-EUA
					NV2500	YLKVLVK-EUA
			Canada	S	NV1500	YLKVLQK-ENC
					NV1500	YLKVLCK-ENC
					NV2500	YLKVLQK-ENA
				SV	NV2500	YLKVLCK-ENA
					NV2500	YLKVLTK-ENA
					NV2500	YLKVLFK-ENA

STANDARD ROOF VAN – VK56VD (5.6L)

Body	Engine	Transmission	Destination	Grade	Equipment	Model	
Standard Roof Van	VK56VD (5.6L)	7 A/T	USA	S	NV2500	YPKVLQS-EUA	
					NV2500	YPKVLCS-EUA	
					NV3500	YPKVLQS-EUB	
				SV	NV2500	YPKVLTS-EUA	
					NV3500	YPKVLTS-EUB	
					NV2500	YPKVLVS-EUA	
				Canada	S	NV2500	YPKVLQS-ENA
						NV2500	YPKVLCS-ENA
						NV3500	YPKVLQS-ENB
			SV		NV3500	YPKVLCS-ENB	
					NV2500	YPKVLTS-ENA	
					NV2500	YPKVLFS-ENA	
			Canada	SV	NV2500	YPKVLTS-ENB	
					NV3500	YPKVLFS-ENB	
					NV3500	YPKVLFS-ENB	

CLASS

[MODEL INFORMATION]

HIGH ROOF VAN – VQ40DE (4.0L)

Body	Engine	Transmission	Destination	Grade	Equipment	Model
High Roof Van	VQ40DE (4.0L)	5 A/T	USA	S	NV2500	ZLKVLOK-EUA
				SV		ZLKVLCCK-EUA
				SL		ZLKVLTCK-EUA
			Canada	S		ZLKVLVK-EUA
				SV		ZLKVLOK-ENA
						ZLKVLCCK-ENA
						ZLKVLTCK-ENA
						ZLKVLFK-ENA

HIGH ROOF VAN – VK56VD (5.6L)

Body	Engine	Transmission	Destination	Grade	Equipment	Model
High Roof Van	VK56VD (5.6L)	7 A/T	USA	S	NV2500	ZPKVLQS-EUA
						ZPKVLCSS-EUA
					NV3500	ZPKVLQS-EUB
				ZPKVLCSS-EUB		
				SV	NV2500	ZPKVLTS-EUA
					NV3500	ZPKVLTS-EUB
			SL		NV2500	ZPKVLVS-EUA
				NV3500	ZPKVLVS-EUB	
			Canada	S	NV2500	ZPKVLQS-ENA
						ZPKVLCSS-ENA
					NV3500	ZPKVLQS-ENB
						ZPKVLCSS-ENB
				SV	NV2500	ZPKVLTS-ENA
						ZPKVLFS-ENA
NV3500	ZPKVLTS-ENB					
	ZPKVLFS-ENB					

2018 Model Variation

2018 Model Year

Position	Character	Qualifier	Definition
1	Y	Body type	Y: Van Standard Roof
			Z: Van High Roof
2	PK	Engine	PK: VK56VD (5.6L)
3			LK: VQ40DE (4.0L)
4	V	Axle	V: 2WD
5	L	Drive	L: LH
6	T	Grade	W: S
			Y: SV with technology package (Canada)
			X: SV
			K: SL
7	K	Transmission	K: 5 A/T S: 7 A/T
8	F80	Model	F80: NV Cargo
9			
10			
11	E	Intake	E: EGI
12	U	Zone	N: Canada
			U: USA
13	A	Equipment	A: NV2500
			B: NV3500
			C: NV1500
14	XXXXX	Option Codes	Option Codes
15			
16			
17			
18			

CLASS

[MODEL INFORMATION]

STANDARD ROOF VAN – VQ40DE (4.0L)

Body	Engine	Transmission	Destination	Grade	Equipment	Model
Standard Roof Van	VQ40DE (4.0L)	5 A/T	USA	S	NV1500	YLKVLWK-EUC
					NV2500	YLKVLWK-EUA
				SV	NV1500	YLKVLXK-EUC
					NV2500	YLKVLXK-EUA
			Canada	S	NV2500	YLKVLKK-EUA
					NV1500	YLKVLWK-ENC
				SV	NV2500	YLKVLWK-ENA
						YLKVLXK-ENA
YLKVLYK-ENA						

STANDARD ROOF VAN – VK56VD (5.6L)

Body	Engine	Transmission	Destination	Grade	Equipment	Model
Standard Roof Van	VK56VD (5.6L)	7 A/T	USA	S	NV2500	YPKVLWS-EUA
					NV3500	YPKVLWS-EUB
				SV	NV2500	YPKVLXS-EUA
					NV3500	YPKVLXS-EUB
				SL	NV3500	YPKVLKS-EUB
					Canada	S
			NV3500	YPKVLWS-ENB		
			SV	NV2500		YPKVLXS-ENA
						YPKVLYS-ENA
			NV3500	YPKVLXS-ENB		
YPKVLYS-ENB						

HIGH ROOF VAN – VQ40DE (4.0L)

Body	Engine	Transmission	Destination	Grade	Equipment	Model
High Roof Van	VQ40DE (4.0L)	5 A/T	USA	S	NV2500	ZLKVLWK-EUA
				SV		ZLKVLXK-EUA
				SL		ZLKVLKK-EUA
			Canada	S		ZLKVLWK-ENA
				SV		ZLKVLXK-ENA
						ZLKVLYK-ENA

CLASS

[MODEL INFORMATION]

HIGH ROOF VAN – VK56VD (5.6L)

Body	Engine	Transmission	Destination	Grade	Equipment	Model
High Roof Van	VK56VD (5.6L)	7 A/T	USA	S	NV2500	ZPKVLWS-EUA
					NV3500	ZPKVLWS-EUB
				SV	NV2500	ZPKVLXS-EUA
					NV3500	ZPKVLXS-EUB
				SL	NV3500	ZPKVLKS-EUB
				Canada	S	NV2500
			NV3500			ZPKVLWS-ENB
			SV		NV2500	ZPKVLXS-ENA
						ZPKVLYS-ENA
			NV3500	ZPKVLXS-ENB		
ZPKVLYS-ENB						

2019-2020 Model Variations

2019-2020 Model Years

Position	Character	Qualifier	Definition
1	Y	Body type	Y: Van Standard Roof
			Z: Van High Roof
2	PK	Engine	PK: VK56VD (5.6L)
3			LK: VQ40DE (4.0L)
4	V	Axle	V: 2WD
5	L	Drive	L: LH
6	T	Grade	W: S
			Y: SV with technology package or navigation package (Canada)
			X: SV
			K: SL
7	K	Transmission	K: 5 A/T S: 7 A/T
8	F80	Model	F80: NV Cargo
9			
10			
11	E	Intake	E: EGI
12	U	Zone	N: Canada
			U: USA
13	A	Equipment	A: NV2500
			B: NV3500
			C: NV1500
14	XXXXX	Option Codes	Option Codes
15			
16			
17			
18			

CLASS

[MODEL INFORMATION]

STANDARD ROOF VAN – VQ40DE (4.0L)

Body	Engine	Transmission	Destination	Grade	Equipment	Model
Standard Roof Van	VQ40DE (4.0L)	5 A/T	USA	S	NV1500	YLKVLWK-EUC
					NV2500	YLKVLWK-EUA
				SV	NV1500	YLKVLXK-EUC
					NV2500	YLKVLXK-EUA
				SL	NV2500	YLKVLKK-EUA
				Canada	S	NV1500
			NV2500			YLKVLWK-ENA
					SV	YLKVLXK-ENA
					YLKVLYK-ENA	

STANDARD ROOF VAN – VK56VD (5.6L)

Body	Engine	Transmission	Destination	Grade	Equipment	Model
Standard Roof Van	VK56VD (5.6L)	7 A/T	USA	S	NV2500	YPKVLWS-EUA
					NV3500	YPKVLWS-EUB
				SV	NV2500	YPKVLXS-EUA
					NV3500	YPKVLXS-EUB
				SL	NV2500	YPKVLKS-EUA
					NV3500	YPKVLKS-EUB
			Canada	S	NV2500	YPKVLWS-ENA
					NV3500	YPKVLWS-ENB
				SV	NV2500	YPKVLXS-ENA
						YPKVLYS-ENA
					NV3500	YPKVLXS-ENB
						YPKVLYS-ENB

HIGH ROOF VAN – VQ40DE (4.0L)

Body	Engine	Transmission	Destination	Grade	Equipment	Model
High Roof Van	VQ40DE (4.0L)	5 A/T	USA	S	NV2500	ZLKVLWK-EUA
				SV		ZLKVLXK-EUA
				SL		ZLKVLKK-EUA
			Canada	S		ZLKVLWK-ENA
				SV		ZLKVLXK-ENA
						ZLKVLYK-ENA

CLASS

[MODEL INFORMATION]

HIGH ROOF VAN – VK56VD (5.6L)

Body	Engine	Transmission	Destination	Grade	Equipment	Model
High Roof Van	VK56VD (5.6L)	7 A/T	USA	S	NV2500	ZPKVLWS-EUA
					NV3500	ZPKVLWS-EUB
				SV	NV2500	ZPKVLXS-EUA
					NV3500	ZPKVLXS-EUB
				SL	NV2500	ZPKVLKS-EUA
					NV3500	ZPKVLKS-EUB
			Canada	S	NV2500	ZPKVLWS-ENA
					NV3500	ZPKVLWS-ENB
				SV	NV2500	ZPKVLXS-ENA
						ZPKVLYS-ENA
					NV3500	ZPKVLXS-ENB
						ZPKVLYS-ENB

2021 Model Variations

2021 Model Year

Position	Character	Qualifier	Definition
1	Y	Body type	Y: Van Standard Roof
			Z: Van High Roof
2	PK	Engine	PK: VK56VD (5.6L)
3			LK: VQ40DE (4.0L)
4	V	Axle	V: 2WD
5	L	Drive	L: LH
6	T	Grade	W: S
			Y: SV with navigation package
			X: SV
			K: SL
7	K	Transmission	K: 5 A/T S: 7 A/T
8	F80	Model	F80: NV Cargo
9			
10			
11	E	Intake	E: EGI
12	U	Zone	N: Canada
			U: USA
13	A	Equipment	A: NV2500
			B: NV3500
			C: NV1500
14	XXXXX	Option Codes	Option Codes
15			
16			
17			
18			

CLASS

[MODEL INFORMATION]

STANDARD ROOF VAN – VQ40DE (4.0L)

Body	Engine	Transmission	Destination	Grade	Equipment	Model
Standard Roof Van	VQ40DE (4.0L)	5 A/T	USA	S	NV1500	YLKVLWK-EUC
					NV2500	YLKVLWK-EUA
				SV	NV1500	YLKVLXK-EUC
					NV2500	YLKVLXK-EUA
			Canada	S	NV1500	YLKVLWK-ENC
				SV	NV2500	YLKVLWK-ENA
					NV2500	YLKVLYK-ENA

STANDARD ROOF VAN – VK56VD (5.6L)

Body	Engine	Transmission	Destination	Grade	Equipment	Model
Standard Roof Van	VK56VD (5.6L)	7 A/T	USA	SV	NV2500	YPKVLXS-EUA
					NV3500	YPKVLXS-EUB
			Canada	S	NV2500	YPKVLWS-ENA
					NV3500	YPKVLWS-ENB
				SV	NV2500	YPKVLYS-ENA
					NV3500	YPKVLYS-ENB

HIGH ROOF VAN – VQ40DE (4.0L)

Body	Engine	Transmission	Destination	Grade	Equipment	Model
High Roof Van	VQ40DE (4.0L)	5 A/T	USA	S	NV2500	ZLKVLWK-EUA
				SV		ZLKVLXK-EUA
			Canada	S		ZLKVLWK-ENA
				SV		ZLKVLYK-ENA

HIGH ROOF VAN – VK56VD (5.6L)

Body	Engine	Transmission	Destination	Grade	Equipment	Model
High Roof Van	VK56VD (5.6L)	7 A/T	USA	SV	NV2500	ZPKVLXS-EUA
					NV3500	ZPKVLXS-EUB
				SL	NV3500	ZPKVLKS-EUB
			Canada	S	NV2500	ZPKVLWS-ENA
					NV3500	ZPKVLWS-ENB
				SV	NV2500	ZPKVLYS-ENA
NV3500	ZPKVLYS-ENB					

GVWR/TOWING CAPACITY

Gross Vehicle Weight Rating (GVWR) is the weight specified by Nissan as the maximum allowable weight for the loaded vehicle.

The GVW of the towing vehicle must not exceed the Gross Vehicle Weight Rating (GVWR) shown on the FMVSS/CMVSS Certification Label. The GVW equals the combined weight of the unloaded vehicle, passengers, luggage, hitch, trailer tongue load and any other optional equipment. In addition, front or rear GAW must not exceed the Gross Axle Weight Rating (GAWR) shown on the FMVSS/CMVSS Certification Label.

Determining Available Towing Capacity

Towing capacities are calculated assuming a base vehicle with driver and any options, modifications, and additional equipment. Additional passengers, cargo and/or optional equipment, such as the trailer hitch, will add weight to the vehicle and reduce the vehicle's maximum towing capacity and trailer tongue weight.

The vehicle and trailer need to be weighed to confirm the vehicle is within the GVWR, front GAWR, rear GAWR, Gross Combined Weight Rating (GCWR) and towing capacity.

All vehicle and trailer weights can be measured using platform-type scales commonly found at truck stops, highway weigh stations, building supply centers or salvage yards.

To determine the available payload capacity for tongue weight, use the following procedure:

1. Locate the GVWR on the [FMVSS/CMVSS Certification Label](#). (pg. 60)
2. Weigh the vehicle on the scale with all of the passengers and cargo that are normally in the vehicle when towing a trailer.
3. Subtract the actual vehicle weight from the GVWR. The remaining amount is the available maximum tongue weight.

To determine the available towing capacity, use the following procedure:

1. Find the GCWR for the vehicle. Use the appropriate Weights Chart in the Resource Charts section of this manual: [RESOURCE CHARTS](#) (pg. 94).
2. Subtract the actual vehicle weight from the GCWR. The remaining amount is the available maximum towing capacity.

To determine the Gross Trailer Weight, weigh the trailer on a scale with all equipment and cargo that are normally in the trailer when it is towed. Make sure the Gross Trailer Weight is not more than the Gross Trailer Weight Rating shown on the trailer and is not more than the calculated available maximum towing capacity.

Also, weigh the front and rear axles on the scale to make sure the Front Gross Axle Weight and Rear Gross Axle Weight are not more than Front Gross Axle Weight and Rear Gross Axle Weight on the FMVSS/CMVSS Certification Label. The cargo in the trailer and vehicle may need to be moved or removed to meet the specified ratings.

Examples:

- Gross Vehicle Weight (GVW) as weighed on a scale - including passengers, cargo and hitch - 2,812 kg (6,200 lbs).
- Gross Vehicle Weight Rating (GVWR) from FMVSS/CMVSS Certification Label - 3,221 kg (7,100 lbs).
- Gross Combined Weight Rating (GCWR) from Resource Chart - 6,849 kg (15,100 lbs).
- Maximum Trailer towing capacity from Resource Chart - 4,173 kg (9,200 lbs).

GVWR	3,221 kg (7,100 lbs)
- GVW	- 2,812 kg (6,200 lbs)
= Available for tongue weight	
	= 408 kg (900 lbs)
GCWR	6,849 kg (15,100 lbs)
- GVW	- 2,812 kg (6,200 lbs)
= Capacity available for towing	
	= 4,036 kg (8,900 lbs)
Available tongue weight	408 kg (900 lbs)
÷ Available capacity	÷ 4,036 kg (8,900 lbs)
Tongue weight = 10%	

The available towing capacity may be less than the maximum towing capacity due to the passenger and cargo load in the vehicle.

Remember to keep trailer tongue weight between 10 - 15% of the trailer weight or within the trailer tongue weight specification recommended by the trailer manufacturer. If the tongue weight becomes excessive, rearrange the cargo to obtain the proper tongue weight. Do not exceed the maximum tongue weight specification shown in the Resource Chart, even if the calculated available tongue weight is greater than 15%. If the calculated tongue weight is less than 10%, reduce the total trailer weight to match the available tongue weight.

Always verify that available capacities are within the required ratings.

VAN OPTION MASS — 2012-2013 MODEL YEARS

OPTION PACKAGE DESCRIPTION	kg (lb)		
	Total	Front	Rear
Power Basic Package: <ul style="list-style-type: none"> ▪ Power windows ▪ Power locks ▪ Remote keyless entry w/(2) key fobs ▪ Cruise control w/steering switch 	1.78 (3.92)	0.70 (1.54)	1.09 (2.40)
Towing Package (V8 Models Only): <ul style="list-style-type: none"> ▪ Tow mirrors (all mirror options) ▪ Front (2) tow hooks ▪ W/tow mode A/T ▪ Class-IV hitch ▪ 7-pin connector pre-wiring ▪ Brake controller pre-wiring 	38.72 (85.38)	4.62 (10.19)	34.10 (75.19)
Power Basic Package w/Towing Package (USA V8 S-Models Only) <ul style="list-style-type: none"> ▪ Power windows ▪ Power locks ▪ Remote keyless entry w/(2) key fobs ▪ Cruise control w/steering switch ▪ Tow mirrors (all mirror options) ▪ Front (2) tow hooks ▪ W/tow mode A/T ▪ Class-IV hitch ▪ 7-pin connector pre-wiring ▪ Brake controller pre-wiring 	40.50 (89.30)	5.32 (11.73)	35.19 (77.59)
Back Door Glass Package (SV-Models Only): <ul style="list-style-type: none"> ▪ Back door windows ▪ Inside rear view mirror ▪ Back window defogger 	5.80 (12.80)	0.17 (0.37)	5.63 (12.41)
Back Door Glass Package w/o Defogger (S-Models Only): <ul style="list-style-type: none"> ▪ Back door windows ▪ Inside rear view mirror 	3.98 (8.78)	-0.88 (-1.94)	4.85 (10.69)
All Around Window Package (High Roof S-Models Only): <ul style="list-style-type: none"> ▪ Mid-side LH (pop out)/RH (fixed) windows ▪ Rear-side LH/RH windows (fixed) ▪ Back door windows ▪ Inside rear view mirror ▪ Back window defogger 	8.70 (19.20)	3.56 (7.85)	5.13 (11.31)
Sliding Door Window Package: <ul style="list-style-type: none"> ▪ RH Sliding door window (fixed) 	8.17 (18.01)	3.49 (7.70)	4.67 (10.30)
Vinyl Seat Upholstery w/Vinyl Armrest (USA NV1500 Models Only)	1.94 (4.28)	1.12 (2.47)	0.82 (1.81)

VAN OPTION MASS — 2012-2013 MODEL YEARS

[MODEL INFORMATION]

OPTION PACKAGE DESCRIPTION		kg (lb)		
		Total	Front	Rear
Vinyl Seat Upholstery With Vinyl Armrest w/o Center Console Assembly (USA NV2500/NV3500 S-Models Only)		-12.86 (-28.36)	-8.18 (-18.04)	-4.68 (-10.32)
Rear Cargo Mat	2012 Model Year	19.20 (42.34)	2.43 (5.36)	16.77 (36.98)
	2013 Model Year	25.03 (55.18)	3.03 (6.68)	22 (48.50)
Navigation Package w/Rear View Camera (USA SV-Models Only):		5.77 (12.72)	3.96 (8.73)	1.81 (3.99)
<ul style="list-style-type: none"> ▪ Navigation system w/AM/FM, 1CD/MP3, AUX, SAT & USB ▪ Bluetooth® hands free phone w/steering switch ▪ Rear view camera 				
Side and Curtain Air Bag Package:		5.64 (12.44)	3.62 (7.98)	2.02 (4.45)
<ul style="list-style-type: none"> ▪ Front seat side air bag ▪ Front seat curtain air bag 				
Splash Guards (Front & Rear) (USA Models Only)		1.19 (2.62)	0.64 (1.41)	0.55 (1.21)

VAN OPTION MASS — 2014 MODEL YEAR

OPTION PACKAGE DESCRIPTION	kg (lb)		
	Total	Front	Rear
Power Basic Package: <ul style="list-style-type: none"> ▪ Power windows ▪ Power locks ▪ Remote keyless entry w/(2) key fobs ▪ Cruise control w/steering switch 	1.78 (3.92)	0.70 (1.54)	1.09 (2.40)
Appearance Package (SV Models Only): <ul style="list-style-type: none"> ▪ Chrome bumpers and grille ▪ Chrome clad wheels ▪ Chrome door handles ▪ Chrome mirror caps ▪ 8-Way power driver seat ▪ Vehicle security system 	3.89 (8.57)	2.61 (5.75)	1.28 (2.82)
Back Door Glass Package: <ul style="list-style-type: none"> ▪ Back door windows (with privacy glass) ▪ Inside rear view mirror ▪ Back window defogger 	5.80 (12.80)	0.17 (0.37)	5.63 (12.41)
All Around Window Package (High Roof S-Models Only): <ul style="list-style-type: none"> ▪ Mid-side LH (pop out)/RH (fixed) windows ▪ Rear-side LH/RH windows (fixed) ▪ Back door windows (with privacy glass) ▪ Inside rear view mirror ▪ Back window defogger 	8.70 (19.20)	3.56 (7.85)	5.13 (11.31)
Sliding Door Window Package: <ul style="list-style-type: none"> ▪ RH Sliding door window (fixed) 	8.17 (18.01)	3.49 (7.70)	4.67 (10.30)
Vinyl Seat Package (USA NV1500 S-Models Only): <ul style="list-style-type: none"> ▪ Vinyl Seat Upholstery 	1.94 (4.28)	1.12 (2.47)	0.82 (1.81)
Rear Cargo Mat	25.03 (55.18)	3.03 (6.68)	22 (48.50)
Technology Package (SV-Models Only): <ul style="list-style-type: none"> ▪ 5 Inch touch-screen SD navigation system w/AM/FM, 1CD/MP3, AUX, XM Satellite Radio, XM traffic & USB ▪ Bluetooth® hands free phone w/steering switch ▪ Integrated rear view camera 	5.77 (12.72)	3.96 (8.73)	1.81 (3.99)
Side and Curtain Air Bag Package: <ul style="list-style-type: none"> ▪ Front seat side air bag ▪ Front seat curtain air bag 	5.64 (12.44)	3.62 (7.98)	2.02 (4.45)
Splash Guards (Front & Rear)	1.19 (2.62)	0.64 (1.41)	0.55 (1.21)

VAN OPTION MASS — 2014 MODEL YEAR

[MODEL INFORMATION]

OPTION PACKAGE DESCRIPTION	kg (lb)		
	Total	Front	Rear
Tow Package (V8 Only) Canada (SV Models) <ul style="list-style-type: none"> ▪ Tow mirrors (all mirror options) ▪ Front (2) Tow Hooks ▪ w/ Tow Mode AT ▪ Class-IV Receiver Hitch ▪ 7-Pin Connector Pre-Wiring ▪ Brake Controller Pre-Wiring 	38.72 (85.38)	4.62 (10.19)	34.10 (75.19)

VAN OPTION MASS — 2015-2016 MODEL YEARS

OPTION PACKAGE DESCRIPTION	kg (lb)		
	Total	Front	Rear
Power Basic Package: USA (S Models) Canada (S Models) <ul style="list-style-type: none"> • Power windows • Power locks • Remote keyless entry w/(2) key fobs • Cruise control w/steering switch 	1.78 (3.92)	0.70 (1.54)	1.09 (2.40)
Appearance Package (SV Models Only): <ul style="list-style-type: none"> • Chrome bumpers and grille • Chrome clad wheels • Chrome door handles • Chrome mirror caps • 8-Way power driver seat • Vehicle security system 	3.89 (8.57)	2.61 (5.75)	1.28 (2.82)
Back Door Glass Package: USA Canada <ul style="list-style-type: none"> • Back door windows (with privacy glass) • Inside rear view mirror • Back window defogger 	5.80 (12.80)	0.17 (0.37)	5.63 (12.41)
All Around Window Package (High Roof S-Models Only): <ul style="list-style-type: none"> • Mid-side LH (pop out)/RH (fixed) windows • Rear-side LH/RH windows (fixed) • Back door windows (with privacy glass) • Inside rear view mirror • Back window defogger 	8.70 (19.20)	3.56 (7.85)	5.13 (11.31)
Sliding Door Window Package: USA Canada (S, SV Models) <ul style="list-style-type: none"> • RH Sliding door window (fixed) 	8.17 (18.01)	3.49 (7.70)	4.67 (10.30)
Vinyl Seat Package (S-Models Only): USA Canada (SV Models) <ul style="list-style-type: none"> • Vinyl Seat Upholstery 	1.94 (4.28)	1.12 (2.47)	0.82 (1.81)
Rear Cargo Mat	25.03 (55.18)	3.03 (6.68)	22 (48.50)
Technology Package (SV, SL Models Only): <ul style="list-style-type: none"> • 5 Inch touch-screen SD navigation system w/AM/FM, 1CD/MP3, AUX, XM Satellite Radio, XM traffic & USB • Bluetooth® hands free phone w/steering switch • Integrated rear view camera 	5.77 (12.72)	3.96 (8.73)	1.81 (3.99)

VAN OPTION MASS — 2015-2016 MODEL YEARS

[MODEL INFORMATION]

OPTION PACKAGE DESCRIPTION	kg (lb)		
	Total	Front	Rear
Side and Curtain Air Bag Package: USA (S, SV Models) <ul style="list-style-type: none"> ▪ Front seat side air bag ▪ Front seat curtain air bag 	5.64 (12.44)	3.62 (7.98)	2.02 (4.45)
Splash Guards (Front & Rear) Canada (S, SV Models)	1.19 (2.62)	0.64 (1.41)	0.55 (1.21)
Tow Package (V8 Only) Canada (SV Models) <ul style="list-style-type: none"> ▪ Tow mirrors (all mirror options) ▪ Front (2) Tow Hooks ▪ w/ Tow Mode AT ▪ Class-IV Receiver Hitch ▪ 7-Pin Connector Pre-Wiring ▪ Brake Controller Pre-Wiring 	38.72 (85.38)	4.62 (10.19)	34.10 (75.19)
Radio package Mexico <ul style="list-style-type: none"> ▪ Without steering switches ▪ Interior trim Simple trim (Cargo) - Lower part ▪ 2DIN AM/FM, 1CD w/AUX, without Bluetooth® hands free phone ▪ Without Cruise Control ▪ Instrument panel 	7.33 (16.16)	2.59 (5.71)	4.74 (10.45)
Ambulance package Mexico <ul style="list-style-type: none"> ▪ Side Glass Dark Tinted Glass: 2nd RH (fixed) ▪ Back door UV reducing dark tinted glass ▪ Interior rear view mirror Manual anti-dazzling ▪ Carpeting materials Front: PVC durable appearance, Rear: without 	8.17 (18.01)	3.49 (7.69)	4.67 (10.30)

VAN OPTION MASS — 2017 MODEL YEAR

OPTION PACKAGE DESCRIPTION	kg (lb)		
	Total	Front	Rear
Power Basic Package: USA (S Model) Canada (S Model) <ul style="list-style-type: none"> ▪ Power Windows (w/ DR one touch down) ▪ Power door locks w/ central locking ▪ Auto Door Lock Function ▪ Cruise control with steering wheel controls ▪ Remote keyless entry w/ 2 fobs 	1.78 (3.92)	0.70 (1.54)	1.09 (2.40)
Rear Door Glass Package: USA Canada <ul style="list-style-type: none"> ▪ Rear door windows (with privacy glass) ▪ Inside rear view mirror ▪ Rear window defogger 	5.80 (12.80)	0.17 (0.37)	5.63 (12.41)
Technology Package USA (SV, SL Models Only): <ul style="list-style-type: none"> ▪ NissanConnect[®] with navigation and mobile apps ▪ 5.8-inch color touch-screen display ▪ Enhanced voice recognition for navigation and audio ▪ USB connection port for iPod[®] interface and other compatible devices ▪ Bluetooth[®] hands-free phone system ▪ Streaming audio via Bluetooth[®] ▪ Hands-free text messaging assistant ▪ NissanConnect[®] Apps ▪ SiriusXM[®] satellite radio ▪ SiriusXM[®] Traffic ▪ SiriusXM Travel Link[®] (Fuel prices, weather, movie listings, and stock info) ▪ Rear view camera 	4.27 (9.42)	2.06 (4.54)	2.21 (4.87)

VAN OPTION MASS — 2017 MODEL YEAR

[MODEL INFORMATION]

OPTION PACKAGE DESCRIPTION	kg (lb)		
	Total	Front	Rear
Technology Package Canada (SV Model Only): <ul style="list-style-type: none"> ▪ NissanConnect® with navigation and mobile apps ▪ Nissan Navigation System with voice guidance ▪ 5.8-inch color touch-screen display ▪ Nissan voice recognition for navigation and audio ▪ SiriusXM® satellite radio ▪ SiriusXM® Traffic ▪ SiriusXM Travel Link® (Fuel prices, weather, movie listings, and stock info) ▪ USB connection port for iPod® interface and other compatible devices ▪ Bluetooth® hands-free phone system ▪ Streaming audio via Bluetooth® ▪ Hands-free text messaging assistant ▪ NissanConnect® Apps ▪ Rear view monitor 	4.27 (9.42)	2.06 (4.54)	2.21 (4.87)
Vinyl Seat Package (S Model Only): USA Canada (SV Models) <ul style="list-style-type: none"> ▪ Vinyl Seat Upholstery 	-13.56 (-29.90)	-8.74 (-19.27)	-4.82 (-10.62)
Speed Limiter (Fleet Only): USA Canada <ul style="list-style-type: none"> ▪ 72 MPH Speed Limiter 	This option package does not affect vehicle mass.		

VAN OPTION MASS — 2018 MODEL YEAR

OPTION PACKAGE DESCRIPTION	kg (lb)		
	Total	Front	Rear
Rear Door Glass Package: USA Canada <ul style="list-style-type: none"> • Rear Door Windows (with Privacy Glass) • Inside Rear View Mirror • Rear Window Defogger 	7.096 (15.65)	1.029 (2.27)	6.067 (13.38)
Navigation Package: USA Canada <p>NissanConnect[®] with Navigation and Mobile Apps</p> <ul style="list-style-type: none"> • Nissan Navigation System with Voice Guidance • 5.8-inch Color Touch-screen Display • Nissan Voice Recognition for Navigation and Audio • SiriusXM[®] Satellite Radio • SiriusXM[®] Traffic • SiriusXM Travel Link[®] (Fuel prices, weather, movie listings, and stock info) • USB Connection Port for iPod[®] Interface and other compatible devices • Streaming Audio via Bluetooth[®] • Hands-free Text Messaging Assistant • NissanConnect[®] Mobile Apps 	4.27 (9.42)	2.06 (4.54)	2.21 (4.87)
Vinyl Seat Package (S Model Only, USA): <ul style="list-style-type: none"> • Vinyl Seat Upholstery 	1.94 (4.28)	1.12 (2.47)	0.82 (1.81)
Speed Limiter (Fleet Only, USA): <ul style="list-style-type: none"> • 72 MPH Speed Limiter 	This option package does not affect vehicle mass.		

VAN OPTION MASS — 2019 MODEL YEAR

OPTION PACKAGE DESCRIPTION	kg (lb)		
	Total	Front	Rear
Rear Door Glass Package: USA Canada <ul style="list-style-type: none"> ▪ Rear Door Windows (with Privacy Glass) ▪ Interior Rear View Mirror ▪ Rear Window Defroster 	5.796 (12.780)	0.169 (0.373)	5.627 (12.408)
Technology Package: USA Canada <p>NissanConnect[®] with Navigation and Mobile Apps</p> <ul style="list-style-type: none"> ▪ Nissan Navigation System with Voice Guidance ▪ 5.8-inch Color Touch-screen Display ▪ Nissan Voice Recognition for Navigation and Audio ▪ SiriusXM[®] Satellite Radio ▪ SiriusXM[®] Traffic ▪ SiriusXM Travel Link[®] (Fuel prices, Weather, Movie listings, and Stock info) ▪ USB Connection Port for iPod[®] Interface and other Compatible Devices ▪ Bluetooth[®] Hands-free Phone System ▪ Streaming Audio via Bluetooth[®] ▪ Hands-free Text Messaging Assistant ▪ NissanConnect[®] Mobile Apps 	4.27 (9.42)	2.06 (4.54)	2.21 (4.87)
Vinyl Seat Package (S Model Only, USA): <ul style="list-style-type: none"> ▪ Vinyl Seat Upholstery 	1.94 (4.28)	1.12 (2.47)	0.82 (1.81)
Speed Limiter (Fleet Only, USA): <ul style="list-style-type: none"> ▪ 72 MPH Speed Limiter 	This option package does not affect vehicle mass.		

VAN OPTION MASS — 2020 MODEL YEAR

USA

OPTION PACKAGE DESCRIPTION	kg (lb)		
	Total	Front	Rear
Rear Door Glass Package: <ul style="list-style-type: none"> • Rear Door Windows (with Privacy Glass) • Interior Rear View Mirror • Rear Window Defroster 	7.096 (15.647)	1.029 (2.269)	6.067 (13.378)
Navigation Package: NissanConnect® with Navigation and Mobile Apps <ul style="list-style-type: none"> • Nissan Navigation System with Voice Guidance • 5.8-inch Color Touch-screen Display • Nissan Voice Recognition for Navigation and Audio • SiriusXM® Satellite Radio • SiriusXM® Traffic • SiriusXM Travel Link® (Fuel prices, Weather, Movie listings, and Stock info) 	4.27 (9.42)	2.06 (4.54)	2.21 (4.87)
Vinyl Seat Package (S Model Only): <ul style="list-style-type: none"> • Vinyl Seat Upholstery 	1.94 (4.28)	1.12 (2.47)	0.82 (1.81)

Canada

OPTION PACKAGE DESCRIPTION	kg (lb)		
	Total	Front	Rear
Rear Door Glass Package: <ul style="list-style-type: none"> • Rear Door Windows (with Privacy Glass) • Interior Rear View Mirror • Rear Window Defroster 	7.096 (15.647)	1.029 (2.269)	6.067 (13.378)
Navigation Package: NissanConnect® with Navigation and Mobile Apps <ul style="list-style-type: none"> • Nissan Navigation System with Voice Guidance • 5.8-inch Color Touch-screen Display • Nissan Voice Recognition for Navigation and Audio • SiriusXM® Satellite Radio • SiriusXM® Traffic • SiriusXM Travel Link® (Fuel prices, Weather, Movie listings, and Stock info) • USB Connection Port for iPod® Interface and other Compatible Devices 	4.27 (9.42)	2.06 (4.54)	2.21 (4.87)

VAN OPTION MASS — 2021 MODEL YEAR

USA

OPTION PACKAGE DESCRIPTION	kg (lb)		
	Total	Front	Rear
Rear Door Glass Package: <ul style="list-style-type: none"> ▪ Rear Door Windows (with Privacy Glass) ▪ Interior Rear View Mirror ▪ Rear Window Defroster 	5.796 (12.780)	0.169 (0.373)	5.627 (12.407)
Navigation Package: NissanConnect® with Navigation and Mobile Apps <ul style="list-style-type: none"> ▪ Nissan Navigation System with Voice Guidance ▪ 5.8-inch Color Touch-screen Display ▪ Nissan Voice Recognition for Navigation and Audio ▪ SiriusXM® Satellite Radio ▪ SiriusXM® Traffic ▪ SiriusXM Travel Link® (Fuel prices, Weather, Movie listings, and Stock info) 	0.55 (1.21)	0.55 (1.21)	—
Vinyl Seat Package (S Model Only): <ul style="list-style-type: none"> ▪ Vinyl Seat Upholstery 	1.94 (4.28)	1.12 (2.47)	0.82 (1.81)

Canada

OPTION PACKAGE DESCRIPTION	kg (lb)		
	Total	Front	Rear
Rear Door Glass Package: <ul style="list-style-type: none"> ▪ Rear Door Windows (with Privacy Glass) ▪ Interior Rear View Mirror ▪ Rear Window Defroster 	5.796 (12.780)	0.169 (0.372)	5.627 (12.407)

RESOURCE CHARTS

WEIGHTS — STANDARD ROOF, 2012 MODEL YEAR

NOTE:

For Accessory Reserve Capacity (ARC), Center of Gravity (CG) or Unloaded Vehicle Weight (UVW) information, refer to [CENTER OF GRAVITY \(CG\) \(pg. 33\)](#).

NOTE:

All specifications are the same for USA and Canada except where indicated.

WEIGHTS — STANDARD ROOF, 2012 MODEL YEAR									
Item	Model Grade Engine	NV1500 S VQ40DE (4.0L)	NV1500 SV VQ40DE (4.0L)	NV2500 S VQ40DE (4.0L)	NV2500 SV VQ40DE (4.0L)	NV2500 S VK56DE (5.6L)	NV2500 SV VK56DE (5.6L)	NV3500 S VK56DE (5.6L)	NV3500 SV VK56DE (5.6L)
Rear Axle Ratio	—	3.36 : 1	3.36 : 1	3.36 : 1	3.36 : 1	3.54 : 1	3.54 : 1	3.54 : 1	3.54 : 1
Base Curb Weight - Total	USA Kg (lbs)	2,626.9 (5,792.3)	2,655.3 (5,854.9)	2,635.4 (5,811.1)	2,677.6 (5,904.1)	2,664.3 (5,874.8)	2,706.5 (5,967.8)	2,666.3 (2,879.2)	2,708.5 (5,972.2)
	Canada Kg (lbs)	2,633.7 (5,807.3)	—	2,642.3 (5,826.3)	2,685.2 (5,920.9)	2,671.2 (5,890.0)	2,748.3 (6,060.0)	2,673.2 (5,894.4)	2,750.3 (6,064.4)
Base Curb Weight - Rear	USA Kg (lbs)	1,243.8 (2,742.6)	1,266.70 (2,805)	1,245.9 (2,747.2)	1,278.9 (2,820.0)	1,243.2 (2,741.3)	1,276.2 (2,813.5)	1,244.2 (2,743.5)	1,277.2 (2,816.2)
	Canada Kg (lbs)	1,246.4 (2,748.3)	—	1,248.5 (2,752.9)	1,281.9 (2,826.6)	1,245.8 (2,747)	1,311.5 (2,891.9)	1,246.8 (2,749.2)	1,312.5 (2,894.1)
Base Curb Weight - Front	USA Kg (lbs)	1,383.1 (3,049.7)	1,388.6 (3,061.9)	1,389.5 (3,063.8)	1,398.7 (3,084.1)	1,421.1 (3,133.5)	1,430.3 (3,153.8)	1,422.1 (3,135.7)	1,431.3 (3,156.0)
	Canada Kg (lbs)	1,387.3 (3,059.0)	—	1,393.8 (3,073.3)	1,403.3 (3,094.3)	1,425.4 (3,143.0)	1,436.8 (3,168.1)	1,426.4 (3,145.2)	1,437.8 (3,173.3)
Maximum GCWR - With Factory Installed Tow Package	Kg (lbs)	—	—	—	—	7,257 (16,002)	7,257 (16,002)	7,257 (16,002)	7,257 (16,002)
Maximum GCWR - Without Factory Installed Tow Package	Kg (lbs)	6,078 (13,402)	6,078 (13,402)	6,078 (13,402)	6,078 (13,402)	6,123 (13,501)	6,123 (13,501)	6,123 (13,501)	6,123 (13,501)

WEIGHTS — STANDARD ROOF, 2012 MODEL YEAR									
Item	Model Grade Engine	NV1500 S VQ40DE (4.0L)	NV1500 SV VQ40DE (4.0L)	NV2500 S VQ40DE (4.0L)	NV2500 SV VQ40DE (4.0L)	NV2500 S VK56DE (5.6L)	NV2500 SV VK56DE (5.6L)	NV3500 S VK56DE (5.6L)	NV3500 SV VK56DE (5.6L)
Maximum GVWR - Max. Pass., Plus Options and Cargo	USA Kg (lbs)	3,878 (8,551)	3,878 (8,551)	4,128 (9,102)	4,128 (9,102)	4,128 (9,102)	4,128 (9,102)	4,491 (9,902)	4,491 (9,902)
	Canada Kg (lbs)	3,878 (8,551)	—	4,128 (9,102)	4,128 (9,102)	4,128 (9,102)	4,128 (9,102)	4,491 (9,902)	4,491 (9,902)
Max. Tires and Load Rating @ 550kPa (80 psi) - Rear	Kg (lbs)	LT245/70R17 1,360 (3,000)	LT245/70R17 1,360 (3,000)	LT245/70R17 1,360 (3,000)	LT245/70R17 1,360 (3,000)	LT245/70R17 1,360 (3,000)	LT245/70R17 1,360 (3,000)	LT245/75R17 1,450 (3,197)	LT245/75R17 1,450 (3,197)
Max. Tires and Load Rating @ 350kPa (50 psi) - Front	Kg (lbs)	LT245/70R17 1,000 (2,205)	LT245/70R17 1,000 (2,205)	LT245/70R17 1,000 (2,205)	LT245/70R17 1,000 (2,205)	LT245/70R17 1,000 (2,205)	LT245/70R17 1,000 (2,205)	LT245/75R17 1,030 (2,271)	LT245/75R17 1,030 (2,271)
Maximum Factory Installed Tow Package Tongue Weight (pg. 288)	Kg (lbs)	—	—	—	—	430.9 (950.1)	430.9 (950.1)	430.9 (950.1)	430.9 (950.1)
Maximum Towing Capacity With Factory Installed Tow Package (pg. 288)	Kg (lbs)	—	—	—	—	4,309 (9,501)	4,309 (9,501)	4,309 (9,501)	4,309 (9,501)
Maximum Dealer Accessory Hitch Tongue Weight (pg. 288)	Kg (lbs)	317.5 (700.1)	317.5 (700.1)	317.5 (700.1)	317.5 (700.1)	317.5 (700.1)	317.5 (700.1)	317.5 (700.1)	317.5 (700.1)

WEIGHTS — STANDARD ROOF, 2012 MODEL YEAR									
Item	Model Grade Engine	NV1500 S VQ40DE (4.0L)	NV1500 SV VQ40DE (4.0L)	NV2500 S VQ40DE (4.0L)	NV2500 SV VQ40DE (4.0L)	NV2500 S VK56DE (5.6L)	NV2500 SV VK56DE (5.6L)	NV3500 S VK56DE (5.6L)	NV3500 SV VK56DE (5.6L)
Maximum Towing Capacity With Dealer Accessory Hitch (pg. 288)	Kg (lbs)	3,175 (7,001)	3,175 (7,001)	3,175 (7,001)	3,175 (7,001)	3,175 (7,001)	3,175 (7,001)	3,175 (7,001)	3,175 (7,001)
Maximum Bumper Tongue Weight (pg. 288)	Kg (lbs)	90.7 (200)	90.7 (200)	90.7 (200)	90.7 (200)	90.7 (200)	90.7 (200)	90.7 (200)	90.7 (200)
Bumper Towing Capacity (pg. 288)	Kg (lbs)	907 (2,000)	907 (2,000)	907 (2,000)	907 (2,000)	907 (2,000)	907 (2,000)	907 (2,000)	907 (2,000)
Standard Payload	USA Kg (lbs)	1,175 (2,590.4)	1,150 (2,535.3)	1,425 (3,141.6)	1,375 (3,031.4)	1,400 (3,086.5)	1,350 (2,976.2)	1,780 (3,925.0)	1,700 (3,747.9)
	Canada Kg (lbs)	1,175 (2,590.4)	—	1,425 (3,141.6)	1,375 (3,031.4)	1,375 (3,031.4)	1,300 (2,866)	1,750 (3,858.1)	1,675 (3,692.7)
Rear GAWR	Kg (lbs)	2,665 (5,875)	2,665 (5,875)	2,665 (5,875)	2,665 (5,875)	2,665 (5,875)	2,665 (5,875)	2,760 (6,086)	2,760 (6,086)
Front GAWR	Kg (lbs)	1,735 (3,825)	1,735 (3,825)	1,735 (3,825)	1,735 (3,825)	1,735 (3,825)	1,735 (3,825)	1,735 (3,825)	1,735 (3,825)
Roof Load Weight Rating (pg. 333)	Kg (lbs)	226.7 (500)	226.7 (500)	226.7 (500)	226.7 (500)	226.7 (500)	226.7 (500)	226.7 (500)	226.7 (500)
Roof Bow Weld Nut Load Rating (pg. 332)	Kg (lbs)	4 (8.8) per pt. 30 (66) across all 10 pts.							
Bulkhead Roof Bow Weld Nut Load Rating (pg. 324)	Kg (lbs)	5 (11) per pt. 30 (66) across all 5 pts.							

WEIGHTS — STANDARD ROOF, 2013–2014 MODEL YEARS

NOTE:

For Accessory Reserve Capacity (ARC), Center of Gravity (CG) or Unloaded Vehicle Weight (UVW) information, refer to [CENTER OF GRAVITY \(CG\) \(pg. 33\)](#).

NOTE:

All specifications are the same for USA, Canada and Mexico except where indicated.

WEIGHTS — STANDARD ROOF, 2013–2014 MODEL YEARS									
Item	Model Grade Engine	NV1500 S VQ40DE (4.0L)	NV1500 SV VQ40DE (4.0L)	NV2500 S VQ40DE (4.0L)	NV2500 SV VQ40DE (4.0L)	NV2500 S VK56DE (5.6L)	NV2500 SV VK56DE (5.6L)	NV3500 S VK56DE (5.6L)	NV3500 SV VK56DE (5.6L)
Rear Axle Ratio	—	3.36 : 1	3.36 : 1	3.36 : 1	3.36 : 1	3.54 : 1	3.54 : 1	3.54 : 1	3.54 : 1
Base Curb Weight - Total	USA Kg (lbs)	2,626.9 (5,792.3)	2,661.2 (5,867.9)	2,635.4 (5,811.1)	2,683.5 (5,917.1)	2,664.3 (5,874.8)	2,712.4 (5,980.8)	2,666.3 (5,879.2)	2,714.4 (5,985.3)
	Canada Kg (lbs)	2,633.7 (5,807.3)	—	2,642.3 (5,826.3)	2,691.0 (5,933.7)	2,671.2 (5,890.0)	2,754.2 (6,073.0)	2,673.2 (5,894.4)	2,756.2 (6,077.4)
	Mexico Kg (lbs)	—	—	2,668.4 (5,883.8)	—	2,698.3 (5,949.8)	—	—	—
Base Curb Weight - Rear	USA Kg (lbs)	1,243.8 (2,742.6)	1,272.0 (2,804.8)	1,245.9 (2,747.2)	1,284.2 (2,831.7)	1,243.2 (2,741.3)	1,281.5 (2,825.7)	1,244.2 (2,743.5)	1,282.5 (2,827.9)
	Canada Kg (lbs)	1,246.4 (2,748.3)	—	1,248.5 (2,752.9)	1,287.1 (2,838.1)	1,245.8 (2,747)	1,316.8 (2,903.5)	1,246.8 (2,749.2)	1,317.8 (2,905.7)
	Mexico Kg (lbs)	—	—	1,275.9 (2,813.4)	—	1,274.2 (2,809.6)	—	—	—
Base Curb Weight - Front	USA Kg (lbs)	1,383.1 (3,049.7)	1,389.2 (3,063.2)	1,389.5 (3,063.8)	1,399.3 (3,085.5)	1,421.1 (3,133.5)	1,430.9 (3,155.1)	1,422.1 (3,135.7)	1,431.9 (3,157.3)
	Canada Kg (lbs)	1,387.3 (3,059)	—	1,393.8 (3,073.3)	1,403.9 (3,095.6)	1,425.4 (3,143.0)	1,437.4 (3,169.5)	1,426.4 (3,145.2)	1,438.4 (3,171.7)
	Mexico Kg (lbs)	—	—	1,392.5 (3,070.5)	—	1,424.1 (3,140.1)	—	—	—
Maximum GCWR - With Factory Installed Tow Package	Kg (lbs)	—	—	—	—	7,257 (16,002)	7,257 (16,002)	7,257 (16,002)	7,257 (16,002)

WEIGHTS — STANDARD ROOF, 2013–2014 MODEL YEARS									
Item	Model Grade Engine	NV1500 S VQ40DE (4.0L)	NV1500 SV VQ40DE (4.0L)	NV2500 S VQ40DE (4.0L)	NV2500 SV VQ40DE (4.0L)	NV2500 S VK56DE (5.6L)	NV2500 SV VK56DE (5.6L)	NV3500 S VK56DE (5.6L)	NV3500 SV VK56DE (5.6L)
Maximum GCWR - Without Factory Installed Tow Package	Kg (lbs)	6,078 (13,402)	6,078 (13,402)	6,078 (13,402)	6,078 (13,402)	6,123 (13,501)	6,123 (13,501)	6,123 (13,501)	6,123 (13,501)
Maximum GVWR - Max. Pass., Plus Options and Cargo	USA Kg (lbs)	3,878 (8,551)	3,878 (8,551)	4,128 (9,100)	4,128 (9,100)	4,128 (9,100)	4,128 (9,100)	4,491 (9,900)	4,491 (9,900)
	Canada Kg (lbs)	3,878 (8,551)	—	4,128 (9,102)	4,128 (9,102)	4,128 (9,102)	4,128 (9,102)	4,491 (9,902)	4,491 (9,902)
Max. Tires and Load Rating @ 550kPa (80 psi) - Rear	Kg (lbs)	LT245/70R17 1,360 (3,000)	LT245/70R17 1,360 (3,000)	LT245/70R17 1,360 (3,000)	LT245/70R17 1,360 (3,000)	LT245/70R17 1,360 (3,000)	LT245/70R17 1,360 (3,000)	LT245/75R17 1,450 (3,197)	LT245/75R17 1,450 (3,197)
Max. Tires and Load Rating @ 350kPa (50 psi) - Front	Kg (lbs)	LT245/70R17 1,000 (2,205)	LT245/70R17 1,000 (2,205)	LT245/70R17 1,000 (2,205)	LT245/70R17 1,000 (2,205)	LT245/70R17 1,000 (2,205)	LT245/70R17 1,000 (2,205)	LT245/75R17 1,030 (2,271)	LT245/75R17 1,030 (2,271)
Maximum Factory Installed Tow Package Tongue Weight (pg. 288)	Kg (lbs)	—	—	—	—	430.9 (950.1)	430.9 (950.1)	430.9 (950.1)	430.9 (950.1)
Maximum Towing Capacity With Factory Installed Tow Package (pg. 288)	Kg (lbs)	—	—	—	—	4,309 (9,501)	4,309 (9,501)	4,309 (9,501)	4,309 (9,501)

WEIGHTS — STANDARD ROOF, 2013–2014 MODEL YEARS

Item	Model Grade Engine	NV1500 S VQ40DE (4.0L)	NV1500 SV VQ40DE (4.0L)	NV2500 S VQ40DE (4.0L)	NV2500 SV VQ40DE (4.0L)	NV2500 S VK56DE (5.6L)	NV2500 SV VK56DE (5.6L)	NV3500 S VK56DE (5.6L)	NV3500 SV VK56DE (5.6L)
Maximum Dealer Accessory Hitch Tongue Weight (pg. 288)	Kg (lbs)	3175 (700.1)	3175 (700.1)	3175 (700.1)	3175 (700.1)	3175 (700.1)	3175 (700.1)	3175 (700.1)	3175 (700.1)
Maximum Towing Capacity With Dealer Accessory Hitch (pg. 288)	Kg (lbs)	3,175 (7,001)	3,175 (7,001)	3,175 (7,001)	3,175 (7,001)	3,175 (7,001)	3,175 (7,001)	3,175 (7,001)	3,175 (7,001)
Maximum Bumper Tongue Weight (pg. 288)	Kg (lbs)	90.7 (200)	90.7 (200)	90.7 (200)	90.7 (200)	90.7 (200)	90.7 (200)	90.7 (200)	90.7 (200)
Bumper Towing Capacity (pg. 288)	Kg (lbs)	907 (2,000)	907 (2,000)	907 (2,000)	907 (2,000)	907 (2,000)	907 (2,000)	907 (2,000)	907 (2,000)
Standard Payload	USA Kg (lbs)	1,175 (2,591)	1,150 (2,536)	1,425 (3,142)	1,375 (3,032.0)	1,400 (3,087)	1,350 (2,977)	1,780 (3,925)	1,700 (3,749)
	Canada Kg (lbs)	1,175 (2,591)	—	1,425 (3,142)	1,375 (3,032)	1,375 (3,032)	1,300 (2,867)	1,750 (3,859)	1,675 (3,693)
	Mexico Kg (lbs)	—	—	1,425 (3,142)	—	1,400 (3,087)	—	—	—
Rear GAWR	Kg (lbs)	2,665 (5,875)	2,665 (5,875)	2,665 (5,875)	2,665 (5,875)	2,665 (5,875)	2,665 (5,875)	2,760 (6,086)	2,760 (6,086)
Front GAWR	Kg (lbs)	1,735 (3,825)	1,735 (3,825)	1,735 (3,825)	1,735 (3,825)	1,735 (3,825)	1,735 (3,825)	1,735 (3,825)	1,735 (3,825)
Roof Load Maximum Weight Rating (pg. 333)	Kg (lbs)	226.7 (500)	226.7 (500)	226.7 (500)	226.7 (500)	226.7 (500)	226.7 (500)	226.7 (500)	226.7 (500)

WEIGHTS — STANDARD ROOF, 2013–2014 MODEL YEARS									
Item	Model Grade Engine	NV1500 S VQ40DE (4.0L)	NV1500 SV VQ40DE (4.0L)	NV2500 S VQ40DE (4.0L)	NV2500 SV VQ40DE (4.0L)	NV2500 S VK56DE (5.6L)	NV2500 SV VK56DE (5.6L)	NV3500 S VK56DE (5.6L)	NV3500 SV VK56DE (5.6L)
Roof Bow Weld Nut Load Rating (pg. 332)	Kg (lbs)	4 (8.8) per pt. 30 (66) across all 10 pts.							
Bulkhead Roof Bow Weld Nut Load Rating (pg. 324)	Kg (lbs)	5 (11) per pt. 30 (66) across all 5 pts.							

WEIGHTS — STANDARD ROOF, 2015-2016 MODEL YEARS

NOTE:

For Accessory Reserve Capacity (ARC), Center of Gravity (CG) or Unloaded Vehicle Weight (UVW) information, refer to [CENTER OF GRAVITY \(CG\) \(pg. 33\)](#).

NOTE:

All specifications are the same for USA and Canada except where indicated.

WEIGHTS — STANDARD ROOF, 2015-2016 MODEL YEARS												
Item	Model Grade Engine	NV1500 S VQ40DE (4.0L)	NV1500 SV VQ40DE (4.0L)	NV2500 S VQ40DE (4.0L)	NV2500 SV VQ40DE (4.0L)	NV2500 SL VQ40DE (4.0L)	NV2500 S VK56DE (5.6L)	NV2500 SV VK56DE (5.6L)	NV2500 SL VK56DE (5.6L)	NV3500 S VK56DE (5.6L)	NV3500 SV VK56DE (5.6L)	NV3500 SL VK56DE (5.6L)
Rear Axle Ratio	—	3.36 : 1	3.36 : 1	3.36 : 1	3.36 : 1	3.36 : 1	3.54 : 1	3.54 : 1	3.54 : 1	3.54 : 1	3.54 : 1	3.54 : 1
Base Curb Weight - Total	USA Kg (lbs)	2,652 (5,847)	2,689 (5,928)	2,643 (5,827)	2,704 (5,961)	2,708 (5,970)	2,672 (5,891)	2,733 (6,025)	2,737 (6,034)	2,674 (5,895)	2,735 (6,030)	2,739 (6,038)
	Canada Kg (lbs)	2,660 (5,865)	—	2,664 (5,875)	2,713 (5,980)	—	2,654 (5,850)	2,737 (6,035)	—	2,656 (5,855)	2,739 (6,038)	—
Base Curb Weight - Rear	USA Kg (lbs)	1,255 (2,767)	1,286 (2,835)	1,251 (2,758)	1,294 (2,853)	1,294 (2,855)	1,249 (2,754)	1,291 (2,848)	1,293 (2,851)	1,249 (2,754)	1,292 (2,848)	1,294 (2,853)
	Canada Kg (lbs)	1,258 (2,775)	—	1,259 (2,775)	1,297 (2,860)	—	1,222 (2,695)	1,293 (2,850)	—	1,223 (2,695)	1,294 (2,855)	—
Base Curb Weight - Front	USA Kg (lbs)	1,397 (3,080)	1,403 (3,093)	1,392 (3,069)	1,410 (3,108)	1,413 (3,115)	1,423 (3,137)	1,441 (3,177)	1,444 (3,183)	1,425 (3,142)	1,443 (3,181)	1,445 (3,186)
	Canada Kg (lbs)	1,402 (3,090)	—	1,405 (3,100)	1,416 (3,120)	—	1,432 (3,160)	1,444 (3,185)	—	1,433 (3,160)	1,445 (3,185)	—
Maximum GCWR - With Factory Installed Tow Package	Kg (lbs)	—	—	—	—	—	7,257 (16,002)	7,257 (16,002)	7,257 (16,002)	7,257 (16,002)	7,257 (16,002)	7,257 (16,002)

WEIGHTS — STANDARD ROOF, 2015-2016 MODEL YEARS												
Item	Model Grade Engine	NV1500 S VQ40DE (4.0L)	NV1500 SV VQ40DE (4.0L)	NV2500 S VQ40DE (4.0L)	NV2500 SV VQ40DE (4.0L)	NV2500 SL VQ40DE (4.0L)	NV2500 S VK56DE (5.6L)	NV2500 SV VK56DE (5.6L)	NV2500 SL VK56DE (5.6L)	NV3500 S VK56DE (5.6L)	NV3500 SV VK56DE (5.6L)	NV3500 SL VK56DE (5.6L)
Maximum GCWR - Without Factory Installed Tow Package	Kg (lbs)	6,078 (13,402)	6,078 (13,402)	6,078 (13,402)	6,078 (13,402)	6,078 (13,402)	6,123 (13,501)	6,123 (13,501)	6,123 (13,501)	6,123 (13,501)	6,123 (13,501)	6,123 (13,501)
Maximum GVWR - Max. Pass., Plus Options and Cargo	USA Kg (lbs)	3,878 (8,550)	3,878 (8,550)	4,128 (9,100)	4,128 (9,100)	4,128 (9,100)	4,128 (9,100)	4,128 (9,100)	4,128 (9,100)	4,491 (9,900)	4,491 (9,900)	4,491 (9,900)
	Canada Kg (lbs)	3,878 (8,550)	—	4,128 (9,100)	4,128 (9,100)	—	4,128 (9,100)	4,128 (9,100)	—	4,491 (9,900)	4,491 (9,900)	—
Max. Tires and Load Rating @ 550kPa (80 psi) - Rear	Kg (lbs)	LT245/70R17 1,360 (3,000)	LT245/70R17 1,360 (3,000)	LT245/70R17 1,360 (3,000)	LT245/70R17 1,360 (3,000)	LT245/70R17 1,360 (3,000)	LT245/70R17 1,360 (3,000)	LT245/70R17 1,360 (3,000)	LT245/70R17 1,360 (3,000)	LT245/75R17 1,450 (3,197)	LT245/75R17 1,450 (3,197)	LT245/75R17 1,450 (3,197)
Max. Tires and Load Rating @ 350kPa (50 psi) - Front	Kg (lbs)	LT245/70R17 1,000 (2,205)	LT245/70R17 1,000 (2,205)	LT245/70R17 1,000 (2,205)	LT245/70R17 1,000 (2,205)	LT245/70R17 1,000 (2,205)	LT245/70R17 1,000 (2,205)	LT245/70R17 1,000 (2,205)	LT245/70R17 1,000 (2,205)	LT245/75R17 1,030 (2,271)	LT245/75R17 1,030 (2,271)	LT245/75R17 1,030 (2,271)
Maximum Factory Installed Tow Package Tongue Weight (pg. 288)	Kg (lbs)	—	—	—	—	—	430.9 (950.1)	430.9 (950.1)	430.9 (950.1)	430.9 (950.1)	430.9 (950.1)	430.9 (950.1)

WEIGHTS — STANDARD ROOF, 2015-2016 MODEL YEARS												
Item	Model Grade Engine	NV1500 S VQ40DE (4.0L)	NV1500 SV VQ40DE (4.0L)	NV2500 S VQ40DE (4.0L)	NV2500 SV VQ40DE (4.0L)	NV2500 SL VQ40DE (4.0L)	NV2500 S VK56DE (5.6L)	NV2500 SV VK56DE (5.6L)	NV2500 SL VK56DE (5.6L)	NV3500 S VK56DE (5.6L)	NV3500 SV VK56DE (5.6L)	NV3500 SL VK56DE (5.6L)
Maximum Towing Capacity With Factory Installed Tow Package (pg. 288)	Kg (lbs)	—	—	—	—	—	4,309 (9,501)	4,309 (9,501)	4,309 (9,501)	4,309 (9,501)	4,309 (9,501)	4,309 (9,501)
Maximum Dealer Accessory Hitch Tongue Weight (pg. 288)	Kg (lbs)	3175 (700.1)	3175 (700.1)	3175 (700.1)	3175 (700.1)	3175 (700.1)	3175 (700.1)	3175 (700.1)	3175 (700.1)	3175 (700.1)	3175 (700.1)	3175 (700.1)
Maximum Towing Capacity With Dealer Accessory Hitch (pg. 288)	Kg (lbs)	3,175 (7,001)	3,175 (7,001)	3,175 (7,001)	3,175 (7,001)	3,175 (7,001)	3,175 (7,001)	3,175 (7,001)	3,175 (7,001)	3,175 (7,001)	3,175 (7,001)	3,175 (7,001)
Maximum Bumper Tongue Weight (pg. 288)	Kg (lbs)	90.7 (200)	90.7 (200)	90.7 (200)	90.7 (200)	90.7 (200)	90.7 (200)	90.7 (200)	90.7 (200)	90.7 (200)	90.7 (200)	90.7 (200)
Bumper Towing Capacity (pg. 288)	Kg (lbs)	907 (2,000)	907 (2,000)	907 (2,000)	907 (2,000)	907 (2,000)	907 (2,000)	907 (2,000)	907 (2,000)	907 (2,000)	907 (2,000)	907 (2,000)

WEIGHTS — STANDARD ROOF, 2015-2016 MODEL YEARS												
Item	Model Grade Engine	NV1500 S VQ40DE (4.0L)	NV1500 SV VQ40DE (4.0L)	NV2500 S VQ40DE (4.0L)	NV2500 SV VQ40DE (4.0L)	NV2500 SL VQ40DE (4.0L)	NV2500 S VK56DE (5.6L)	NV2500 SV VK56DE (5.6L)	NV2500 SL VK56DE (5.6L)	NV3500 S VK56DE (5.6L)	NV3500 SV VK56DE (5.6L)	NV3500 SL VK56DE (5.6L)
Standard Payload	USA Kg (lbs)	1,175 (2,590)	1,100 (2,425)	1,425 (3,141)	1,350 (2,976)	1,350 (2,976)	1,375 (3,031)	1,300 (2,866)	1,300 (2,866)	1,750 (3,858)	1,675 (3,692)	1,675 (3,692)
	Canada Kg (lbs)	1,175 (2,591)	—	1,425 (3,142)	1,375 (3,031)	—	1,375 (3,032)	1,300 (2,867)	—	1,750 (3,859)	1,675 (3,693)	—
Rear GAWR	Kg (lbs)	2,665 (5,875)	2,665 (5,875)	2,665 (5,875)	2,665 (5,875)	2,665 (5,875)	2,665 (5,875)	2,665 (5,875)	2,665 (5,875)	2,760 (6,086)	2,760 (6,086)	2,760 (6,086)
Front GAWR	Kg (lbs)	1,735 (3,825)	1,735 (3,825)	1,735 (3,825)	1,735 (3,825)	1,735 (3,825)	1,735 (3,825)	1,735 (3,825)	1,735 (3,825)	1,735 (3,825)	1,735 (3,825)	1,735 (3,825)
Roof Load Maximum Weight Rating (pg. 333)	Kg (lbs)	226.7 (500)	226.7 (500)	226.7 (500)	226.7 (500)	226.7 (500)	226.7 (500)	226.7 (500)	226.7 (500)	226.7 (500)	226.7 (500)	226.7 (500)
Roof Bow Weld Nut Load Rating (pg. 332)	Kg (lbs)	4 (8.8) per pt. 30 (66) across all 10 pts.										
Bulkhead Roof Bow Weld Nut Load Rating (pg. 324)	Kg (lbs)	5 (11) per pt. 30 (66) across all 5 pts.										

WEIGHTS — STANDARD ROOF, 2017 MODEL YEAR**NOTE:**

For Accessory Reserve Capacity (ARC), Center of Gravity (CG) or Unloaded Vehicle Weight (UVW) information, refer to [CENTER OF GRAVITY \(CG\) \(pg. 33\)](#).

NOTE:

All specifications are the same for USA and Canada except where indicated.

WEIGHTS — STANDARD ROOF, 2017 MODEL YEAR												
Item	Model Grade Engine	NV1500 S VQ40DE (4.0L)	NV1500 SV VQ40DE (4.0L)	NV2500 S VQ40DE (4.0L)	NV2500 SV VQ40DE (4.0L)	NV2500 SL VQ40DE (4.0L)	NV2500 S VK56VD (5.6L)	NV2500 SV VK56VD (5.6L)	NV2500 SL VK56VD (5.6L)	NV3500 S VK56VD (5.6L)	NV3500 SV VK56VD (5.6L)	NV3500 SL VK56VD (5.6L)
Rear Axle Ratio	—	3.36 : 1					3.54 : 1					
Base Curb Weight - Total	USA Kg (lbs)	2,633 (5,806)	2,682 (5,913)	2,634 (5,807)	2,699 (5,950)	2,706 (5,965)	2,732 (6,023)	2,796 (6,165)	2,803 (6,180)	2,736 (6,031)	2,800 (6,173)	2,807 (6,188)
	Canada Kg (lbs)	2,637 (5,814)	—	2,659 (5,862)	2,708 (5,969)	—	2,718 (5,992)	2,805 (6,185)	—	2,723 (6,003)	2,810 (6,196)	—
Base Curb Weight - Rear	USA Kg (lbs)	1,247 (2,749)	1,284 (2,831)	1,247 (2,750)	1,293 (2,850)	1,296 (2,856)	1,283 (2,829)	1,328 (2,929)	1,331 (2,935)	1,285 (2,833)	1,330 (2,933)	1,333 (2,939)
	Canada Kg (lbs)	1,248 (2,752)	—	1,258 (2,773)	1,296 (2,858)	—	1,259 (2,777)	1,332 (2,937)	—	1,262 (2,782)	1,334 (2,942)	—
Base Curb Weight - Front	USA Kg (lbs)	1,387 (3,057)	1,398 (3,082)	1,387 (3,057)	1,406 (3,100)	1,410 (3,108)	1,449 (3,194)	1,468 (3,236)	1,472 (3,245)	1,451 (3,198)	1,470 (3,240)	1,474 (3,249)
	Canada Kg (lbs)	1,389 (3,062)	—	1,401 (3,089)	1,411 (3,111)	—	1,459 (3,216)	1,473 (3,248)	—	1,461 (3,221)	1,476 (3,254)	—
Maximum GCWR	Kg (lbs)	6,078 (13,400)					7,257 (16,000)					
Maximum GVWR - Max. Pass., Plus Options and Cargo	USA Kg (lbs)	3,878 (8,550)			4,128 (9,100)				4,491 (9,900)			
	Canada Kg (lbs)	3,878 (8,550)	—	4,128 (9,100)		—	4,128 (9,100)		—	4,491 (9,900)		—

WEIGHTS — STANDARD ROOF, 2017 MODEL YEAR													
Item	Model Grade Engine	NV1500 S VQ40DE (4.0L)	NV1500 SV VQ40DE (4.0L)	NV2500 S VQ40DE (4.0L)	NV2500 SV VQ40DE (4.0L)	NV2500 SL VQ40DE (4.0L)	NV2500 S VK56VD (5.6L)	NV2500 SV VK56VD (5.6L)	NV2500 SL VK56VD (5.6L)	NV3500 S VK56VD (5.6L)	NV3500 SV VK56VD (5.6L)	NV3500 SL VK56VD (5.6L)	
Max. Tires and Load Rating @ 550kPa (80 psi) - Rear	Kg (lbs)	LT245/70R17 1,360 (3,000)							LT245/75R17 1,450 (3,197)				
Max. Tires and Load Rating @ 350kPa (50 psi) - Front	Kg (lbs)	LT245/70R17 1,000 (2,205)							LT245/75R17 1,030 (2,271)				
Maximum Factory Installed Tow Package Tongue Weight (pg. 288)	USA Kg (lbs)	—					426 (940)						
	Canada Kg (lbs)	313 (690)	—	313 (690)	—	426 (940)	—	426 (940)	—	—	—		
Maximum Towing Capacity With Factory Installed Tow Package (pg. 288)	USA Kg (lbs)	—					4,264 (9,400)						
	Canada Kg (lbs)	3,130 (6,900)	—	3,130 (6,900)	3,130 (6,900)	—	4,264 (9,400)	4,264 (9,400)	—	4,264 (9,400)	4,264 (9,400)	—	
Maximum Dealer Accessory Hitch Tongue Weight (pg. 288)	USA only Kg (lbs)	313 (690)					—						

WEIGHTS — STANDARD ROOF, 2017 MODEL YEAR													
Item	Model Grade Engine	NV1500 S VQ40DE (4.0L)	NV1500 SV VQ40DE (4.0L)	NV2500 S VQ40DE (4.0L)	NV2500 SV VQ40DE (4.0L)	NV2500 SL VQ40DE (4.0L)	NV2500 S VK56VD (5.6L)	NV2500 SV VK56VD (5.6L)	NV2500 SL VK56VD (5.6L)	NV3500 S VK56VD (5.6L)	NV3500 SV VK56VD (5.6L)	NV3500 SL VK56VD (5.6L)	
Maximum Towing Capacity With Dealer Accessory Hitch (pg. 288)	USA only Kg (lbs)	3,130 (6,900)					—						
Maximum Bumper Tongue Weight (pg. 288)	Kg (lbs)	90.7 (200)											
Bumper Towing Capacity (pg. 288)	Kg (lbs)	907 (2,000)											
Standard Payload	USA Kg (lbs)	1,175 (2,590)	1,125 (2,480)	1,425 (3,142)	1,375 (3,031)	1,375 (3,031)	1,350 (2,976)	1,300 (2,866)	1,275 (2,811)	1,700 (3,748)	1,650 (3,638)	1,650 (3,638)	
	Canada Kg (lbs)	1,175 (2,590)	—	1,425 (3,142)	1,350 (2,976)	—	1,375 (3,031)	1,275 (2,811)	—	1,725 (3,803)	1,650 (3,638)	—	
Rear GAWR	Kg (lbs)	2,665 (5,875)								2,760 (6,085)			
Front GAWR	Kg (lbs)	1,735 (3,825)											
Roof Load Maximum Weight Rating (pg. 333)	Kg (lbs)	226.7 (500)											
Roof Bow Weld Nut Load Rating (pg. 332)	Kg (lbs)	4 (8.8) per pt. 30 (66) across all 10 pts.											

WEIGHTS – STANDARD ROOF, 2017 MODEL YEAR												
Item	Model Grade Engine	NV1500 S VQ40DE (4.0L)	NV1500 SV VQ40DE (4.0L)	NV2500 S VQ40DE (4.0L)	NV2500 SV VQ40DE (4.0L)	NV2500 SL VQ40DE (4.0L)	NV2500 S VK56VD (5.6L)	NV2500 SV VK56VD (5.6L)	NV2500 SL VK56VD (5.6L)	NV3500 S VK56VD (5.6L)	NV3500 SV VK56VD (5.6L)	NV3500 SL VK56VD (5.6L)
Bulkhead Roof Bow Weld Nut Load Rating (pg. 324)	Kg (lbs)	5 (11) per pt. 30 (66) across all 5 pts.										

WEIGHTS — STANDARD ROOF, 2018 MODEL YEAR

NOTE:

For Accessory Reserve Capacity (ARC), Center of Gravity (CG) or Unloaded Vehicle Weight (UVW) information, refer to [CENTER OF GRAVITY \(CG\) \(pg. 33\)](#).

NOTE:

All specifications are the same for USA and Canada except where indicated.

WEIGHTS — STANDARD ROOF, 2018 MODEL YEAR												
Item	Model Grade Engine	NV1500 S VQ40DE (4.0L)	NV1500 SV VQ40DE (4.0L)	NV2500 S VQ40DE (4.0L)	NV2500 SV VQ40DE (4.0L)	NV2500 SL VQ40DE (4.0L)	NV2500 S VK56VD (5.6L)	NV2500 SV VK56VD (5.6L)	NV2500 SL VK56VD (5.6L)	NV3500 S VK56VD (5.6L)	NV3500 SV VK56VD (5.6L)	NV3500 SL VK56VD (5.6L)
Rear Axle Ratio	—	3.36 : 1					3.54 : 1					
Base Curb Weight - Total	USA Kg (lbs)	2,638.5 (5,817.0)	2,685.3 (5,920.1)	2,639.2 (5,818.5)	2,701.8 (5,956.5)	2,708.3 (5,970.8)	2,737.0 (6,033.9)	2,799.6 (6,172.0)	2,806.0 (6,186.1)	2,740.6 (6,041.9)	2,803.2 (6,179.9)	2,809.6 (6,194.0)
	Canada Kg (lbs)	2,642.3 (5,825.3)	—	2,664.0 (5,873.2)	2,710.8 (5,976.4)	—	2,723.0 (6,003.1)	2,808.6 (6,191.8)	—	2,727.8 (6,013.7)	2,813.4 (6,202.4)	—
Base Curb Weight - Rear	USA Kg (lbs)	1,248.4 (2,752.2)	1,284.7 (2,832.2)	1,249.0 (2,753.5)	1,293.1 (2,850.7)	1,295.8 (2,856.7)	1,284.8 (2,832.5)	1,328.9 (2,929.7)	1,331.6 (2,935.7)	1,286.6 (2,836.5)	1,330.7 (2,933.7)	1,333.4 (2,939.6)
	Canada Kg (lbs)	1,250.0 (2,755.7)	—	1,259.3 (2,776.2)	1,296.8 (2,858.9)	—	1,261.0 (2,780.0)	1,332.6 (2,937.9)	—	1,263.2 (2,784.9)	1,334.8 (2,942.7)	—
Base Curb Weight - Front	USA Kg (lbs)	1,390.2 (3,064.8)	1,400.7 (3,088.0)	1,390.3 (3,065.0)	1,408.8 (3,105.8)	1,412.6 (3,114.2)	1,452.2 (3,201.5)	1,470.7 (3,242.2)	1,474.4 (3,250.4)	1,454.0 (3,205.4)	1,472.5 (3,246.2)	1,476.2 (3,254.4)
	Canada Kg (lbs)	1,392.4 (3,069.7)	—	1,404.8 (3,097.0)	1,414.1 (3,117.5)	—	1,462.0 (3,223.1)	1,476.0 (3,253.9)	—	1,464.6 (3,228.8)	1,478.6 (3,259.7)	—
Maximum GCWR	Kg (lbs)	6,078 (13,400)					6,123 (13,500)			7,257 (16,000)		
Maximum GVWR - Max. Pass., Plus Options and Cargo	USA Kg (lbs)	3,878 (8,550)		4,128 (9,100)						4,491 (9,900)		
	Canada Kg (lbs)	3,878 (8,550)	—	4,128 (9,100)		—	4,128 (9,100)		—	4,491 (9,900)		—

WEIGHTS — STANDARD ROOF, 2018 MODEL YEAR												
Item	Model Grade Engine	NV1500 S VQ40DE (4.0L)	NV1500 SV VQ40DE (4.0L)	NV2500 S VQ40DE (4.0L)	NV2500 SV VQ40DE (4.0L)	NV2500 SL VQ40DE (4.0L)	NV2500 S VK56VD (5.6L)	NV2500 SV VK56VD (5.6L)	NV2500 SL VK56VD (5.6L)	NV3500 S VK56VD (5.6L)	NV3500 SV VK56VD (5.6L)	NV3500 SL VK56VD (5.6L)
Max. Tires and Load Rating @ 550kPa (80 psi) - Rear	Kg (lbs)	LT245/70R17 1,360 (3,000)							LT245/75R17 1,450 (3,197)			
Max. Tires and Load Rating @ 350kPa (50 psi) - Front	Kg (lbs)	LT245/70R17 1,000 (2,205)							LT245/75R17 1,030 (2,271)			
Maximum Factory Installed Tow Package Tongue Weight (pg. 288)	USA Kg (lbs)	—					426 (940)					
	Canada Kg (lbs)	313 (690)	—	313 (690)	—	426 (940)	—	426 (940)	—			
Maximum Towing Capacity With Factory Installed Tow Package (pg. 288)	USA Kg (lbs)	—					4,264 (9,400)					
	Canada Kg (lbs)	3,130 (6,900)	—	3,130 (6,900)	3,130 (6,900)	—	4,264 (9,400)	4,264 (9,400)	—	4,264 (9,400)	4,264 (9,400)	—
Maximum Dealer Accessory Hitch Tongue Weight (pg. 288)	USA only Kg (lbs)	313 (690)					—					

WEIGHTS — STANDARD ROOF, 2018 MODEL YEAR													
Item	Model Grade Engine	NV1500 S VQ40DE (4.0L)	NV1500 SV VQ40DE (4.0L)	NV2500 S VQ40DE (4.0L)	NV2500 SV VQ40DE (4.0L)	NV2500 SL VQ40DE (4.0L)	NV2500 S VK56VD (5.6L)	NV2500 SV VK56VD (5.6L)	NV2500 SL VK56VD (5.6L)	NV3500 S VK56VD (5.6L)	NV3500 SV VK56VD (5.6L)	NV3500 SL VK56VD (5.6L)	
Maximum Towing Capacity With Dealer Accessory Hitch (pg. 288)	USA only Kg (lbs)	3,130 (6,900)					—						
Maximum Bumper Tongue Weight (pg. 288)	Kg (lbs)	91 (200)											
Bumper Towing Capacity (pg. 288)	Kg (lbs)	907 (2,000)											
Standard Payload	USA Kg (lbs)	1,238 (2,730)	1,188 (2,620)	1,488 (3,280)	1,424 (3,140)	1,415 (3,120)	1,388 (3,060)	1,324 (2,920)	1,320 (2,910)	1,746 (3,850)	1,687 (3,720)	1,678 (3,700)	
	Canada Kg (lbs)	1,234 (2,720)	—	1,461 (3,220)	1,415 (3,120)	—	1,402 (3,090)	1,315 (2,900)	—	1,760 (3,880)	1,674 (3,690)	—	
Rear GAWR	Kg (lbs)	2,665 (5,875)								2,760 (6,085)			
Front GAWR	Kg (lbs)	1,735 (3,825)											
Roof Load Maximum Weight Rating (pg. 333)	Kg (lbs)	226.7 (500)											
Roof Bow Weld Nut Load Rating (pg. 332)	Kg (lbs)	4 (8.8) per pt. 30 (66) across all 10 pts.											

WEIGHTS – STANDARD ROOF, 2018 MODEL YEAR												
Item	Model Grade Engine	NV1500 S VQ40DE (4.0L)	NV1500 SV VQ40DE (4.0L)	NV2500 S VQ40DE (4.0L)	NV2500 SV VQ40DE (4.0L)	NV2500 SL VQ40DE (4.0L)	NV2500 S VK56VD (5.6L)	NV2500 SV VK56VD (5.6L)	NV2500 SL VK56VD (5.6L)	NV3500 S VK56VD (5.6L)	NV3500 SV VK56VD (5.6L)	NV3500 SL VK56VD (5.6L)
Bulkhead Roof Bow Weld Nut Load Rating (pg. 324)	Kg (lbs)	5 (11) per pt. 30 (66) across all 5 pts.										

WEIGHTS — STANDARD ROOF, 2019 MODEL YEAR

NOTE:

For Accessory Reserve Capacity (ARC), Center of Gravity (CG) or Unloaded Vehicle Weight (UVW) information, refer to [CENTER OF GRAVITY \(CG\) \(pg. 33\)](#).

NOTE:

All specifications are the same for USA and Canada except where indicated.

WEIGHTS — STANDARD ROOF, 2019 MODEL YEAR												
Item	Model Grade Engine	NV1500 S VQ40DE (4.0L)	NV1500 SV VQ40DE (4.0L)	NV2500 S VQ40DE (4.0L)	NV2500 SV VQ40DE (4.0L)	NV2500 SL VQ40DE (4.0L)	NV2500 S VK56VD (5.6L)	NV2500 SV VK56VD (5.6L)	NV2500 SL VK56VD (5.6L)	NV3500 S VK56VD (5.6L)	NV3500 SV VK56VD (5.6L)	NV3500 SL VK56VD (5.6L)
Rear Axle Ratio	—	3.36 : 1					3.54 : 1					
Base Curb Weight - Total	USA Kg (lbs)	2,638.6 (5,817.0)	2,685.4 (5,920.2)	2,639.3 (5,818.6)	2,701.9 (5,956.6)	2,708.4 (5,970.9)	2,737.0 (6,034.0)	2,799.6 (6,172.0)	2,806.0 (6,186.1)	2,740.6 (6,041.9)	2,803.2 (6,180.0)	2,809.6 (6,194.1)
	Canada Kg (lbs)	2,643.1 (5,827.0)	—	2,664.7 (5,874.6)	2,711.6 (5,978.0)	—	2,723.9 (6,005.1)	2,809.2 (6,193.2)	—	2,728.6 (6,015.5)	2,814.0 (6,203.8)	—
Base Curb Weight - Rear	USA Kg (lbs)	1,248.4 (2,752.2)	1,284.7 (2,832.2)	1,249.0 (2,753.5)	1,293.1 (2,850.7)	1,295.8 (2,856.7)	1,284.8 (2,832.5)	1,328.9 (2,929.7)	1,331.6 (2,935.7)	1,286.6 (2,836.5)	1,330.7 (2,933.7)	1,333.4 (2,939.7)
	Canada Kg (lbs)	1,250.3 (2,756.4)	—	1,259.6 (2,776.9)	1,297.1 (2,859.6)	—	1,261.3 (2,780.7)	1,332.9 (2,938.6)	—	1,263.6 (2,785.8)	1,335.1 (2,943.4)	—
Base Curb Weight - Front	USA Kg (lbs)	1,390.2 (3,064.8)	1,400.7 (3,088.0)	1,390.3 (3,065.1)	1,408.8 (3,105.8)	1,412.6 (3,114.2)	1,452.2 (3,201.5)	1,470.7 (3,242.3)	1,474.4 (3,250.4)	1,454.0 (3,205.5)	1,472.5 (3,246.3)	1,476.2 (3,254.4)
	Canada Kg (lbs)	1,392.8 (3,070.6)	—	1,405.1 (3,097.7)	1,414.5 (3,118.4)	—	1,462.6 (3,224.4)	1,476.3 (3,254.6)	—	1,465.0 (3,229.7)	1,478.9 (3,260.4)	—
Maximum GCWR	Kg (lbs)	6,078 (13,400)					6,123 (13,500)			7,257 (16,000)		
Maximum GVWR - Max. Pass., Plus Options and Cargo	USA Kg (lbs)	3,878 (8,550)		4,128 (9,100)					4,491 (9,900)			
	Canada Kg (lbs)	3,878 (8,550)	—	4,128 (9,100)		—	4,128 (9,100)		—	4,491 (9,900)		—

WEIGHTS — STANDARD ROOF, 2019 MODEL YEAR												
Item	Model Grade Engine	NV1500 S VQ40DE (4.0L)	NV1500 SV VQ40DE (4.0L)	NV2500 S VQ40DE (4.0L)	NV2500 SV VQ40DE (4.0L)	NV2500 SL VQ40DE (4.0L)	NV2500 S VK56VD (5.6L)	NV2500 SV VK56VD (5.6L)	NV2500 SL VK56VD (5.6L)	NV3500 S VK56VD (5.6L)	NV3500 SV VK56VD (5.6L)	NV3500 SL VK56VD (5.6L)
Max. Tires and Load Rating @ 550kPa (80 psi) - Rear	Kg (lbs)	LT245/70R17 1,360 (3,000)						LT245/75R17 1,450 (3,197)				
Max. Tires and Load Rating @ 350kPa (50 psi) - Front	Kg (lbs)	LT245/70R17 1,000 (2,205)						LT245/75R17 1,030 (2,271)				
Maximum Factory Installed Tow Package Tongue Weight (pg. 288)	USA Kg (lbs)	—				426 (940)						
	Canada Kg (lbs)	313 (690)	—	313 (690)	—	426 (940)	—	426 (940)	—			
Maximum Towing Capacity With Factory Installed Tow Package (pg. 288)	USA Kg (lbs)	—				4,264 (9,400)						
	Canada Kg (lbs)	3,130 (6,900)	—	3,130 (6,900)	3,130 (6,900)	—	4,264 (9,400)	4,264 (9,400)	—	4,264 (9,400)	4,264 (9,400)	—
Maximum Dealer Accessory Hitch Tongue Weight (pg. 288)	USA only Kg (lbs)	313 (690)				—						

WEIGHTS — STANDARD ROOF, 2019 MODEL YEAR													
Item	Model Grade Engine	NV1500 S VQ40DE (4.0L)	NV1500 SV VQ40DE (4.0L)	NV2500 S VQ40DE (4.0L)	NV2500 SV VQ40DE (4.0L)	NV2500 SL VQ40DE (4.0L)	NV2500 S VK56VD (5.6L)	NV2500 SV VK56VD (5.6L)	NV2500 SL VK56VD (5.6L)	NV3500 S VK56VD (5.6L)	NV3500 SV VK56VD (5.6L)	NV3500 SL VK56VD (5.6L)	
Maximum Towing Capacity With Dealer Accessory Hitch (pg. 288)	USA only Kg (lbs)	3,130 (6,900)					—						
Maximum Bumper Tongue Weight (pg. 288)	Kg (lbs)	91 (200)											
Bumper Towing Capacity (pg. 288)	Kg (lbs)	907 (2,000)											
Standard Payload	USA Kg (lbs)	1,238 (2,730)	1,188 (2,620)	1,488 (3,280)	1,424 (3,140)	1,415 (3,120)	1,388 (3,060)	1,324 (2,920)	1,320 (2,910)	1,746 (3,850)	1,687 (3,720)	1,678 (3,700)	
	Canada Kg (lbs)	1,234 (2,720)	—	1,461 (3,220)	1,415 (3,120)	—	1,402 (3,090)	1,315 (2,900)	—	1,760 (3,880)	1,674 (3,690)	—	
Rear GAWR	Kg (lbs)	2,665 (5,875)								2,760 (6,085)			
Front GAWR	Kg (lbs)	1,735 (3,825)											
Roof Load Maximum Weight Rating (pg. 333)	Kg (lbs)	226.7 (500)											
Roof Bow Weld Nut Load Rating (pg. 332)	Kg (lbs)	4 (8.8) per pt. 30 (66) across all 10 pts.											

WEIGHTS – STANDARD ROOF, 2019 MODEL YEAR												
Item	Model Grade Engine	NV1500 S VQ40DE (4.0L)	NV1500 SV VQ40DE (4.0L)	NV2500 S VQ40DE (4.0L)	NV2500 SV VQ40DE (4.0L)	NV2500 SL VQ40DE (4.0L)	NV2500 S VK56VD (5.6L)	NV2500 SV VK56VD (5.6L)	NV2500 SL VK56VD (5.6L)	NV3500 S VK56VD (5.6L)	NV3500 SV VK56VD (5.6L)	NV3500 SL VK56VD (5.6L)
Bulkhead Roof Bow Weld Nut Load Rating (pg. 324)	Kg (lbs)	5 (11) per pt. 30 (66) across all 5 pts.										

WEIGHTS — STANDARD ROOF, 2020 MODEL YEAR**NOTE:**

For Accessory Reserve Capacity (ARC), Center of Gravity (CG) or Unloaded Vehicle Weight (UVW) information, refer to [CENTER OF GRAVITY \(CG\) \(pg. 33\)](#).

NOTE:

All specifications are the same for USA and Canada except where indicated.

WEIGHTS — STANDARD ROOF, 2020 MODEL YEAR												
Item	Model Grade Engine	NV1500 S VQ40DE (4.0L)	NV1500 SV VQ40DE (4.0L)	NV2500 S VQ40DE (4.0L)	NV2500 SV VQ40DE (4.0L)	NV2500 SL VQ40DE (4.0L)	NV2500 S VK56VD (5.6L)	NV2500 SV VK56VD (5.6L)	NV2500 SL VK56VD (5.6L)	NV3500 S VK56VD (5.6L)	NV3500 SV VK56VD (5.6L)	NV3500 SL VK56VD (5.6L)
Rear Axle Ratio	—	3.36 : 1					3.54 : 1					
Base Curb Weight - Total	USA Kg (lbs)	2,638.6 (5,817.0)	2,685.4 (5,920.2)	2,639.3 (5,818.6)	2,701.9 (5,956.6)	2,708.4 (5,970.9)	2,737.0 (6,034.0)	2,799.6 (6,172.0)	2,806.0 (6,186.1)	2,740.6 (6,041.9)	2,803.2 (6,180.0)	2,809.6 (6,194.1)
	Canada Kg (lbs)	2,643.1 (5,827.0)	—	2,664.7 (5,874.6)	2,750.3 (6,063.3)	—	2,723.9 (6,005.1)	2,809.2 (6,193.2)	—	2,728.6 (6,015.5)	2,814.0 (6,203.8)	—
Base Curb Weight - Rear	USA Kg (lbs)	1,248.4 (2,752.2)	1,284.7 (2,832.2)	1,249.0 (2,753.5)	1,293.1 (2,850.7)	1,295.8 (2,856.7)	1,284.8 (2,832.5)	1,328.9 (2,929.7)	1,331.6 (2,935.7)	1,286.6 (2,836.5)	1,330.7 (2,933.7)	1,333.4 (2,939.7)
	Canada Kg (lbs)	1,250.3 (2,756.4)	—	1,259.6 (2,776.9)	1,331.2 (2,934.7)	—	1,261.3 (2,780.7)	1,332.9 (2,938.6)	—	1,263.6 (2,785.8)	1,335.1 (2,943.4)	—
Base Curb Weight - Front	USA Kg (lbs)	1,390.2 (3,064.8)	1,400.7 (3,088.0)	1,390.3 (3,065.1)	1,408.8 (3,105.8)	1,412.6 (3,114.2)	1,452.2 (3,201.5)	1,470.7 (3,242.3)	1,474.4 (3,250.4)	1,454.0 (3,205.5)	1,472.5 (3,246.3)	1,476.2 (3,254.4)
	Canada Kg (lbs)	1,392.8 (3,070.6)	—	1,405.1 (3,097.7)	1,419.1 (3,128.5)	—	1,462.6 (3,224.4)	1,476.3 (3,254.6)	—	1,465.0 (3,229.7)	1,478.9 (3,260.4)	—
Maximum GCWR	Kg (lbs)	6,078 (13,400)					6,123 (13,500)			7,257 (16,000)		
Maximum GVWR - Max. Pass., Plus Options and Cargo	USA Kg (lbs)	3,878 (8,550)		4,128 (9,100)						4,491 (9,900)		
	Canada Kg (lbs)	3,878 (8,550)	—	4,128 (9,100)		—	4,128 (9,100)		—	4,491 (9,900)		—

WEIGHTS — STANDARD ROOF, 2020 MODEL YEAR												
Item	Model Grade Engine	NV1500 S VQ40DE (4.0L)	NV1500 SV VQ40DE (4.0L)	NV2500 S VQ40DE (4.0L)	NV2500 SV VQ40DE (4.0L)	NV2500 SL VQ40DE (4.0L)	NV2500 S VK56VD (5.6L)	NV2500 SV VK56VD (5.6L)	NV2500 SL VK56VD (5.6L)	NV3500 S VK56VD (5.6L)	NV3500 SV VK56VD (5.6L)	NV3500 SL VK56VD (5.6L)
Max. Tires and Load Rating @ 550kPa (80 psi) - Rear	Kg (lbs)	LT245/70R17 1,360 (3,000)						LT245/75R17 1,450 (3,197)				
Max. Tires and Load Rating @ 350kPa (50 psi) - Front	Kg (lbs)	LT245/70R17 1,000 (2,205)						LT245/75R17 1,030 (2,271)				
Maximum Factory Installed Tow Package Tongue Weight (pg. 288)	USA Kg (lbs)	—				426 (940)						
	Canada Kg (lbs)	313 (690)	—	313 (690)	—	426 (940)	—	426 (940)	—			
Maximum Towing Capacity With Factory Installed Tow Package (pg. 288)	USA Kg (lbs)	—				4,264 (9,400)						
	Canada Kg (lbs)	3,130 (6,900)	—	3,130 (6,900)	3,130 (6,900)	—	4,264 (9,400)	4,264 (9,400)	—	4,264 (9,400)	4,264 (9,400)	—
Maximum Dealer Accessory Hitch Tongue Weight (pg. 288)	USA only Kg (lbs)	313 (690)				—						

WEIGHTS — STANDARD ROOF, 2020 MODEL YEAR													
Item	Model Grade Engine	NV1500 S VQ40DE (4.0L)	NV1500 SV VQ40DE (4.0L)	NV2500 S VQ40DE (4.0L)	NV2500 SV VQ40DE (4.0L)	NV2500 SL VQ40DE (4.0L)	NV2500 S VK56VD (5.6L)	NV2500 SV VK56VD (5.6L)	NV2500 SL VK56VD (5.6L)	NV3500 S VK56VD (5.6L)	NV3500 SV VK56VD (5.6L)	NV3500 SL VK56VD (5.6L)	
Maximum Towing Capacity With Dealer Accessory Hitch (pg. 288)	USA only Kg (lbs)	3,130 (6,900)					—						
Maximum Bumper Tongue Weight (pg. 288)	Kg (lbs)	91 (200)											
Bumper Towing Capacity (pg. 288)	Kg (lbs)	907 (2,000)											
Standard Payload	USA Kg (lbs)	1,238 (2,730)	1,188 (2,620)	1,488 (3,280)	1,424 (3,140)	1,415 (3,120)	1,388 (3,060)	1,324 (2,920)	1,320 (2,910)	1,746 (3,850)	1,687 (3,720)	1,678 (3,700)	
	Canada Kg (lbs)	1,234 (2,720)	—	1,461 (3,220)	1,374 (3,030)	—	1,402 (3,090)	1,315 (2,900)	—	1,760 (3,880)	1,674 (3,690)	—	
Rear GAWR	Kg (lbs)	2,665 (5,875)							2,760 (6,085)				
Front GAWR	Kg (lbs)	1,735 (3,825)											
Roof Load Maximum Weight Rating (pg. 333)	Kg (lbs)	226.7 (500)											
Roof Bow Weld Nut Load Rating (pg. 332)	Kg (lbs)	4 (8.8) per pt. 30 (66) across all 10 pts.											

WEIGHTS — STANDARD ROOF, 2020 MODEL YEAR												
Item	Model Grade Engine	NV1500 S VQ40DE (4.0L)	NV1500 SV VQ40DE (4.0L)	NV2500 S VQ40DE (4.0L)	NV2500 SV VQ40DE (4.0L)	NV2500 SL VQ40DE (4.0L)	NV2500 S VK56VD (5.6L)	NV2500 SV VK56VD (5.6L)	NV2500 SL VK56VD (5.6L)	NV3500 S VK56VD (5.6L)	NV3500 SV VK56VD (5.6L)	NV3500 SL VK56VD (5.6L)
Bulkhead Roof Bow Weld Nut Load Rating (pg. 324)	Kg (lbs)	5 (11) per pt. 30 (66) across all 5 pts.										

WEIGHTS — STANDARD ROOF, 2021 MODEL YEAR

NOTE:

For Accessory Reserve Capacity (ARC), Center of Gravity (CG) or Unloaded Vehicle Weight (UVW) information, refer to [CENTER OF GRAVITY \(CG\) \(pg. 33\)](#).

NOTE:

All specifications are the same for USA and Canada except where indicated.

WEIGHTS — STANDARD ROOF, 2021 MODEL YEAR										
Item	Model Grade Engine	NV1500 S VQ40DE (4.0L)	NV1500 SV VQ40DE (4.0L)	NV2500 S VQ40DE (4.0L)	NV2500 SV VQ40DE (4.0L)	NV2500 S VK56VD (5.6L)	NV2500 SV VK56VD (5.6L)	NV3500 S VK56VD (5.6L)	NV3500 SV VK56VD (5.6L)	NV3500 SL VK56VD (5.6L)
Rear Axle Ratio	—	3.36 : 1				3.54 : 1				
Base Curb Weight - Total	USA Kg (lbs)	2,639.7 (5,819.5)	2,686.5 (5,922.7)	2,640.4 (5,821.1)	2,703.0 (5,959.1)	—	2,800.7 (6,174.5)	2,741.7 (6,044.4)	2,804.3 (6,182.4)	2,810.7 (6,196.5)
	Canada Kg (lbs)	2,644.2 (5,829.4)	—	2,665.9 (5,877.3)	2,752.0 (6,067.1)	2,725.0 (6,007.6)	2,810.4 (6,195.9)	2,729.7 (6,018.0)	2,815.2 (6,206.5)	—
Base Curb Weight - Rear	USA Kg (lbs)	1,248.5 (2,752.4)	1,284.8 (2,832.4)	1,249.1 (2,753.7)	1,293.2 (2,851.0)	—	1,329.0 (2,930.0)	1,286.7 (2,836.7)	1,330.8 (2,933.9)	1,333.5 (2,939.9)
	Canada Kg (lbs)	1,250.4 (2,756.6)	—	1,259.7 (2,777.1)	1,331.3 (2,935.0)	1,261.4 (2,780.9)	1,333.0 (2,938.8)	1,263.7 (2,786.0)	1,335.2 (2,943.6)	—
Base Curb Weight - Front	USA Kg (lbs)	1,391.2 (3,067.1)	1,401.7 (3,090.2)	1,391.3 (3,067.3)	1,409.8 (3,108.1)	—	1,471.7 (3,244.5)	1,455.0 (3,207.7)	1,473.5 (3,248.5)	1,477.2 (3,256.7)
	Canada Kg (lbs)	1,393.8 (3,072.8)	—	1,406.2 (3,100.2)	1,420.7 (3,132.1)	1,463.6 (3,226.7)	1,477.4 (3,257.1)	1,466.0 (3,232.0)	1,480.0 (3,262.8)	—
Maximum GCWR	Kg (lbs)	6,078 (13,400)				7,257 (16,000)				
Maximum GVWR - Max. Pass., Plus Options and Cargo	USA Kg (lbs)	3,878 (8,550)		4,128 (9,100)			4,491 (9,900)			
	Canada Kg (lbs)	3,878 (8,550)	—	4,128 (9,100)		4,128 (9,100)		4,491 (9,900)		—

WEIGHTS — STANDARD ROOF, 2021 MODEL YEAR										
Item	Model Grade Engine	NV1500 S VQ40DE (4.0L)	NV1500 SV VQ40DE (4.0L)	NV2500 S VQ40DE (4.0L)	NV2500 SV VQ40DE (4.0L)	NV2500 S VK56VD (5.6L)	NV2500 SV VK56VD (5.6L)	NV3500 S VK56VD (5.6L)	NV3500 SV VK56VD (5.6L)	NV3500 SL VK56VD (5.6L)
Max. Tires and Load Rating @ 550kPa (80 psi) - Rear	Kg (lbs)	LT245/70R17 1,360 (3,000)						LT245/75R17 1,450 (3,197)		
Max. Tires and Load Rating @ 350kPa (50 psi) - Front	Kg (lbs)	LT245/70R17 1,000 (2,205)						LT245/75R17 1,030 (2,271)		
Maximum Factory Installed Tow Package Tongue Weight (pg. 288)	USA Kg (lbs)	—				426 (940)				
	Canada Kg (lbs)	313 (690)	—	313 (690)		426 (940)		426 (940)		—
Maximum Towing Capacity With Factory Installed Tow Package (pg. 288)	USA Kg (lbs)	—				4,264 (9,400)				
	Canada Kg (lbs)	3,130 (6,900)	—	3,130 (6,900)		4,264 (9,400)		4,264 (9,400)		—
Maximum Dealer Accessory Hitch Tongue Weight (pg. 288)	USA only Kg (lbs)	313 (690)				—				

WEIGHTS — STANDARD ROOF, 2021 MODEL YEAR										
Item	Model Grade Engine	NV1500 S VQ40DE (4.0L)	NV1500 SV VQ40DE (4.0L)	NV2500 S VQ40DE (4.0L)	NV2500 SV VQ40DE (4.0L)	NV2500 S VK56VD (5.6L)	NV2500 SV VK56VD (5.6L)	NV3500 S VK56VD (5.6L)	NV3500 SV VK56VD (5.6L)	NV3500 SL VK56VD (5.6L)
Maximum Towing Capacity With Dealer Accessory Hitch (pg. 288)	USA only Kg (lbs)	3,130 (6,900)				—				
Maximum Bumper Tongue Weight (pg. 288)	Kg (lbs)	91 (200)								
Bumper Towing Capacity (pg. 288)	Kg (lbs)	907 (2,000)								
Standard Payload	USA Kg (lbs)	1,238 (2,730)	1,188 (2,620)	1,483 (3,270)	1,424 (3,140)	—	1,324 (2,920)	1,746 (3,850)	1,683 (3,710)	1,678 (3,700)
	Canada Kg (lbs)	1,234 (2,720)	—	1,461 (3,220)	1,374 (3,030)	1,402 (3,090)	1,315 (2,900)	1,760 (3,880)	1,674 (3,690)	—
Rear GAWR	Kg (lbs)	2,665 (5,875)					2,760 (6,085)			
Front GAWR	Kg (lbs)	1,735 (3,825)								
Roof Load Maximum Weight Rating (pg. 333)	Kg (lbs)	226.7 (500)								
Roof Bow Weld Nut Load Rating (pg. 332)	Kg (lbs)	4 (8.8) per pt. 30 (66) across all 10 pts.								

WEIGHTS — STANDARD ROOF, 2021 MODEL YEAR										
Item	Model Grade Engine	NV1500 S VQ40DE (4.0L)	NV1500 SV VQ40DE (4.0L)	NV2500 S VQ40DE (4.0L)	NV2500 SV VQ40DE (4.0L)	NV2500 S VK56VD (5.6L)	NV2500 SV VK56VD (5.6L)	NV3500 S VK56VD (5.6L)	NV3500 SV VK56VD (5.6L)	NV3500 SL VK56VD (5.6L)
Bulkhead Roof Bow Weld Nut Load Rating (pg. 324)	Kg (lbs)	5 (11) per pt. 30 (66) across all 5 pts.								

INTERIOR MEASUREMENTS — STANDARD ROOF

NOTE:

All specifications are the same for USA, Canada and Mexico except where indicated.

INTERIOR MEASUREMENTS — STANDARD ROOF									
Item	Model Grade Engine	NV1500 S V6 Engine	NV1500 SV V6 Engine	NV2500 S V6 Engine	NV2500 SV/SL* V6 Engine	NV2500 S V8 Engine	NV2500 SV/SL* V8 Engine	NV3500 S V8 Engine	NV3500 SV/SL* V8 Engine
Maximum Cargo Width at Wheel Wells (pg. 174)	mm (in)	1,378 (54.25)	1,378 (54.25)	1,378 (54.25)	1,378 (54.25)	1,378 (54.25)	1,378 (54.25)	1,378 (54.25)	1,378 (54.25)
Maximum Cargo Width at Floor Rear (pg. 174)	mm (in)	1,783 (70.2)	1,783 (70.2)	1,783 (70.2)	1,783 (70.2)	1,783 (70.2)	1,783 (70.2)	1,783 (70.2)	1,783 (70.2)
Maximum Cargo Height (pg. 174)	Without Cargo Mat mm (in)	1,359 (53.5)	1,359 (53.5)	1,359 (53.5)	1,359 (53.5)	1,359 (53.5)	1,359 (53.5)	1,359 (53.5)	1,359 (53.5)
	With Cargo Mat mm (in)	1,350 (53.15)	1,350 (53.15)	1,350 (53.15)	1,350 (53.15)	1,350 (53.15)	1,350 (53.15)	1,350 (53.15)	1,350 (53.15)
Maximum Cargo Length at Floor - Behind Center Console at Vehicle Center	mm (in)	2,954 (116.3)	2,954 (116.3)	2,954 (116.3)	2,954 (116.3)	2,954 (116.3)	2,954 (116.3)	2,954 (116.3)	2,954 (116.3)
Maximum Cargo Length at Floor - Without Center Console at Vehicle Center	mm (in)	3,679 (144.84)	3,679 (144.84)	3,679 (144.84)	3,679 (144.84)	3,679 (144.84)	3,679 (144.84)	3,679 (144.84)	3,679 (144.84)

INTERIOR MEASUREMENTS — STANDARD ROOF									
Item	Model Grade Engine	NV1500 S V6 Engine	NV1500 SV V6 Engine	NV2500 S V6 Engine	NV2500 SV/SL* V6 Engine	NV2500 S V8 Engine	NV2500 SV/SL* V8 Engine	NV3500 S V8 Engine	NV3500 SV/SL* V8 Engine
Maximum Cargo Length at Floor - Behind Seat (pg. 174)	mm (in)	3,016 (118.74)	3,016 (118.74)	3,016 (118.74)	3,016 (118.74)	3,016 (118.74)	3,016 (118.74)	3,016 (118.74)	3,016 (118.74)
Maximum Cargo Length Behind Seat Back (pg. 174)	mm (in)	3,186 (125.43)	3,186 (125.43)	3,186 (125.43)	3,186 (125.43)	3,186 (125.43)	3,186 (125.43)	3,186 (125.43)	3,186 (125.43)
Cargo Volume	m ³ (ft ³)	6.6 (234.1)	6.6 (234.1)	6.6 (234.1)	6.6 (234.1)	6.6 (234.1)	6.6 (234.1)	6.6 (234.1)	6.6 (234.1)

*: SL grade new for 2015 model year.

EXTERIOR MEASUREMENTS — STANDARD ROOF

NOTE:

All specifications are the same for USA, Canada and Mexico except where indicated.

EXTERIOR MEASUREMENTS — STANDARD ROOF									
Item	Model Grade Engine	NV1500 S V6 Engine	NV1500 SV V6 Engine	NV2500 S V6 Engine	NV2500 SV/SL* V6 Engine	NV2500 S V8 Engine	NV2500 SV/SL* V8 Engine	NV3500 S V8 Engine	NV3500 SV/SL* V8 Engine
Vehicle Height (pg. 211)	mm (in)	2,131 (83.9)	2,131 (83.9)	2,131 (83.9)	2,131 (83.9)	2,131 (83.9)	2,131 (83.9)	2,156 (84.9)	2,156 (84.9)
Wheelbase (pg. 211)	mm (in)	3,710 (146.1)	3,710 (146.1)	3,710 (146.1)	3,710 (146.1)	3,710 (146.1)	3,710 (146.1)	3,710 (146.1)	3,710 (146.1)
Wheel Type (pg. 351)	—	Steel	Styled Steel	Styled Steel	SV: Styled Steel	Styled Steel	SV: Styled Steel	Styled Steel	SV: Styled Steel
					SL*: Styled - Chrome Clad		SL*: Styled - Chrome Clad		SL*: Styled - Chrome Clad
Front Tread Width	mm (in)	1,745 (68.7)	1,745 (68.7)	1,745 (68.7)	1,745 (68.7)	1,745 (68.7)	1,745 (68.7)	1,745 (68.7)	1,745 (68.7)
Rear Tread Width	mm (in)	1,750 (68.9)	1,750 (68.9)	1,750 (68.9)	1,750 (68.9)	1,750 (68.9)	1,750 (68.9)	1,750 (68.9)	1,750 (68.9)
Turning Radius (pg. 350)	m (ft)	13.8 (45.2)	13.8 (45.2)	13.8 (45.2)	13.8 (45.2)	13.8 (45.2)	13.8 (45.2)	13.8 (45.2)	13.8 (45.2)
Cargo Area Liftover Height (pg. 211)	mm (in)	725 (28.5)	725 (28.5)	725 (28.5)	725 (28.5)	725 (28.5)	725 (28.5)	725 (28.5)	725 (28.5)

EXTERIOR MEASUREMENTS – STANDARD ROOF									
Item	Model Grade Engine	NV1500 S V6 Engine	NV1500 SV V6 Engine	NV2500 S V6 Engine	NV2500 SV/SL* V6 Engine	NV2500 S V8 Engine	NV2500 SV/SL* V8 Engine	NV3500 S V8 Engine	NV3500 SV/SL* V8 Engine
Slide Door Opening Width - Maximum Clearance, Without Door (pg. 204)	Without Door Seal and Interior Trim mm (in)	1,115 (43.90)	1,115 (43.90)	1,115 (43.90)	1,115 (43.90)	1,115 (43.90)	1,115 (43.90)	1,115 (43.90)	1,115 (43.90)
	With Door Seal and Interior Trim mm (in)	1,106 (43.54)	1,106 (43.54)	1,106 (43.54)	1,106 (43.54)	1,106 (43.54)	1,106 (43.54)	1,106 (43.54)	1,106 (43.54)
Slide Door Opening Width - Maximum Clearance, With Door (pg. 206)	Without Door Seal mm (in)	1,096 (43.15)	1,096 (43.15)	1,096 (43.15)	1,096 (43.15)	1,096 (43.15)	1,096 (43.15)	1,096 (43.15)	1,096 (43.15)
	With Door Seal mm (in)	1,092 (42.99)	1,092 (42.99)	1,092 (42.99)	1,092 (42.99)	1,092 (42.99)	1,092 (42.99)	1,092 (42.99)	1,092 (42.99)

EXTERIOR MEASUREMENTS — STANDARD ROOF									
Item	Model Grade Engine	NV1500 S V6 Engine	NV1500 SV V6 Engine	NV2500 S V6 Engine	NV2500 SV/SL* V6 Engine	NV2500 S V8 Engine	NV2500 SV/SL* V8 Engine	NV3500 S V8 Engine	NV3500 SV/SL* V8 Engine
Slide Door Opening Height - Maximum Clearance (pg. 204)	Without Door Seal and Interior Trim mm (in)	1,512 (59.53)	1,512 (59.53)	1,512 (59.53)	1,512 (59.53)	1,512 (59.53)	1,512 (59.53)	1,512 (59.53)	1,512 (59.53)
	With Door Seal and Interior Trim mm (in)	1,502 (59.13)	1,502 (59.13)	1,502 (59.13)	1,502 (59.13)	1,502 (59.13)	1,502 (59.13)	1,502 (59.13)	1,502 (59.13)
Vehicle Length (pg. 211)	mm (in)	6,112 (240.6)	6,112 (240.6)	6,112 (240.6)	6,112 (240.6)	6,112 (240.6)	6,112 (240.6)	6,112 (240.6)	6,112 (240.6)
Front Overhang (pg. 211)	mm (in)	1,063 (41.9)	1,063 (41.9)	1,063 (41.9)	1,063 (41.9)	1,063 (41.9)	1,063 (41.9)	1,063 (41.9)	1,063 (41.9)
Rear Overhang (pg. 211)	mm (in)	1,339 (52.7)	1,339 (52.7)	1,339 (52.7)	1,339 (52.7)	1,339 (52.7)	1,339 (52.7)	1,339 (52.7)	1,339 (52.7)

EXTERIOR MEASUREMENTS — STANDARD ROOF									
Item	Model Grade Engine	NV1500 S V6 Engine	NV1500 SV V6 Engine	NV2500 S V6 Engine	NV2500 SV/SL* V6 Engine	NV2500 S V8 Engine	NV2500 SV/SL* V8 Engine	NV3500 S V8 Engine	NV3500 SV/SL* V8 Engine
Rear Door Opening Height - Maximum Clearance (pg. 208)	Without Door Seal and Cargo Mat mm (in)	1,302 (51.26)	1,302 (51.26)	1,302 (51.26)	1,302 (51.26)	1,302 (51.26)	1,302 (51.26)	1,302 (51.26)	1,302 (51.26)
	With Door Seal and Cargo Mat mm (in)	1,290 (50.79)	1,290 (50.79)	1,290 (50.79)	1,290 (50.79)	1,290 (50.79)	1,290 (50.79)	1,290 (50.79)	1,290 (50.79)
Rear Door Opening Width - Maximum Clearance (pg. 208)	Without Door Seal mm (in)	1,572 (61.89)	1,572 (61.89)	1,572 (61.89)	1,572 (61.89)	1,572 (61.89)	1,572 (61.89)	1,572 (61.89)	1,572 (61.89)
	With Door Seal mm (in)	1,564 (61.57)	1,564 (61.57)	1,564 (61.57)	1,564 (61.57)	1,564 (61.57)	1,564 (61.57)	1,564 (61.57)	1,564 (61.57)
Vehicle Width - Without Mirrors (pg. 211)	mm (in)	2,030 (79.9)	2,030 (79.9)	2,030 (79.9)	2,030 (79.9)	2,030 (79.9)	2,030 (79.9)	2,030 (79.9)	2,030 (79.9)
Vehicle Width - Without Tow Mirrors (pg. 210)	mm (in)	2,466 (97.09)	2,466 (97.09)	2,466 (97.09)	2,466 (97.09)	2,466 (97.09)	2,466 (97.09)	2,466 (97.09)	2,466 (97.09)
Vehicle Width - With Tow Mirrors Non-Extended (pg. 210)	mm (in)	—	—	2,610 (102.8)	2,610 (102.8)	2,610 (102.8)	2,610 (102.8)	2,610 (102.8)	2,610 (102.8)
Vehicle Width - With Tow Mirrors Extended (pg. 210)	mm (in)	—	—	2,758 (108.6)	2,758 (108.6)	2,758 (108.6)	2,758 (108.6)	2,758 (108.6)	2,758 (108.6)
Ground Clearance	mm (in)	205 (8.1)	205 (8.1)	205 (8.1)	205 (8.1)	205 (8.1)	205 (8.1)	205 (8.1)	205 (8.1)

EXTERIOR MEASUREMENTS – STANDARD ROOF									
Item	Model Grade Engine	NV1500 S V6 Engine	NV1500 SV V6 Engine	NV2500 S V6 Engine	NV2500 SV/SL* V6 Engine	NV2500 S V8 Engine	NV2500 SV/SL* V8 Engine	NV3500 S V8 Engine	NV3500 SV/SL* V8 Engine
Step-in Height - Front	mm (in)	457 (18)	457 (18)	457 (18)	457 (18)	457 (18)	457 (18)	475 (18.7)	475 (18.7)
Step-in Height - Slide Door	mm (in)	493 (19.4)	493 (19.4)	493 (19.4)	493 (19.4)	493 (19.4)	493 (19.4)	513 (20.2)	513 (20.2)
Step-in Height - Rear	mm (in)	503 (19.8)	503 (19.8)	503 (19.8)	503 (19.8)	503 (19.8)	503 (19.8)	531 (20.9)	531 (20.9)

*: SL grade new for 2015 model year.

132 **WEIGHTS — HIGH ROOF, 2012 MODEL YEAR**

NOTE:
For Accessory Reserve Capacity (ARC), Center of Gravity (CG) or Unloaded Vehicle Weight (UVW) information, refer to [CENTER OF GRAVITY \(CG\) \(pg. 33\)](#).

NOTE:
All specifications are the same for USA and Canada except where indicated.

WEIGHTS — HIGH ROOF, 2012 MODEL YEAR							
Item	Model Grade Engine	NV2500 S VQ40DE (4.0L)	NV2500 SV VQ40DE (4.0L)	NV2500 S VK56DE (5.6L)	NV2500 SV VK56DE (5.6L)	NV3500 S VK56DE (5.6L)	NV3500 SV VK56DE (5.6L)
Rear Axle Ratio	—	3.36 : 1	3.36 : 1	3.54 : 1	3.54 : 1	3.54 : 1	3.54 : 1
Base Curb Weight - Total	USA Kg (lbs)	2,709.5 (5,974.4)	2,751.7 (6,067.5)	2,742.4 (6,047.0)	2,784.6 (6,140.0)	2,744.4 (6,051.4)	2,786.6 (6,144.6)
	Canada Kg (lbs)	2,716.4 (5,989.7)	2,759.3 (6,084.3)	2,768.4 (6,104.3)	2,826.4 (6,232.2)	2,751.3 (6,066.6)	2,828.4 (6,236.6)
Base Curb Weight - Rear	USA Kg (lbs)	1,303.8 (2,874.9)	1,336.8 (2,947.6)	1,303.8 (2,874.9)	1,341.3 (2,957.6)	1,309.3 (2,887.0)	1,342.3 (2,959.8.)
	Canada Kg (lbs)	1,306.4 (2,880.6)	1,339.8 (2,954.3)	1,327.6 (2,927.4)	1,376.6 (3,035.4)	1,311.9 (2,892.7)	1,377.6 (3,037.6)
Base Curb Weight - Front	USA Kg (lbs)	1,405.7 (3,099.6)	1,414.9 (3,119.9)	1,434.1 (3,162.2)	1,443.3 (3,182.5)	1,435.1 (3,164.4)	1,444.3 (3,184.7)
	Canada Kg (lbs)	1,410.0 (3,109)	1,419.5 (3,130.0)	1,440.8 (3,177.0)	1,449.8 (3,196.8)	1,439.4 (3,173.9)	1,450.8 (3,199.0)
Maximum GCWR - With Factory Installed Tow Package	Kg (lbs)	—	—	7,257 (16,000)	7,257 (16,000)	7,257 (16,000)	7,257 (16,000)
Maximum GCWR - Without Factory Installed Tow Package	Kg (lbs)	6,078 (13,402)	6,078 (13,402)	6,123 (13,501)	6,123 (13,501)	6,123 (13,501)	6,123 (13,501)
Maximum GVWR - Max. Pass., Plus Options and Cargo	USA Kg (lbs)	3,878 (8,551)	3,878 (8,551)	4,128 (9,100)	4,128 (9,100)	4,491 (9,900)	4,491 (9,900)
	Canada Kg (lbs)	4,128 (9,102)	4,128 (9,102)	4,128 (9,102)	4,128 (9,102)	4,491 (9,902)	4,491 (9,902)

2012-2021 NV 1500/2500/3500 CARGO VAN

WEIGHTS — HIGH ROOF, 2012 MODEL YEAR

[RESOURCE CHARTS]

WEIGHTS — HIGH ROOF, 2012 MODEL YEAR							
Item	Model Grade Engine	NV2500 S VQ40DE (4.0L)	NV2500 SV VQ40DE (4.0L)	NV2500 S VK56DE (5.6L)	NV2500 SV VK56DE (5.6L)	NV3500 S VK56DE (5.6L)	NV3500 SV VK56DE (5.6L)
Max. Tires and Load Rating @ 550kPa (80 psi) - Rear	Kg (lbs)	LT245/70R17 1,360 (3,000)	LT245/70R17 1,360 (3,000)	LT245/70R17 1,360 (3,000)	LT245/70R17 1,360 (3,000)	LT245/75R17 1,450 (3,197)	LT245/75R17 1,450 (3,197)
Max. Tires and Load Rating @ 350kPa (50 psi) - Front	Kg (lbs)	LT245/70R17 1,000 (2,205)	LT245/70R17 1,000 (2,205)	LT245/70R17 1,000 (2,205)	LT245/70R17 1,000 (2,205)	LT245/75R17 1,030 (2,271)	LT245/75R17 1,030 (2,271)
Maximum Factory Installed Tow Package Tongue Weight (pg. 288)	Kg (lbs)	430.9 (950)	430.9 (950)	430.9 (950)	430.9 (950)	430.9 (950)	430.9 (950)
Maximum Towing Capacity With Factory Installed Tow Package (pg. 288)	Kg (lbs)	4,309 (9,501)	4,309 (9,501)	4,309 (9,501)	4,309 (9,501)	4,309 (9,501)	4,309 (9,501)
Maximum Dealer Accessory Hitch Tongue Weight (pg. 288)	Kg (lbs)	317.5 (700)	317.5 (700)	317.5 (700)	317.5 (700)	317.5 (700)	317.5 (700)
Maximum Towing Capacity With Dealer Accessory Hitch (pg. 288)	Kg (lbs)	3,175 (7,001)	3,175 (7,001)	3,175 (7,001)	3,175 (7,001)	3,175 (7,001)	3,175 (7,001)
Maximum Bumper Tongue Weight (pg. 288)	Kg (lbs)	90.7 (200)	90.7 (200)	90.7 (200)	90.7 (200)	90.7 (200)	90.7 (200)
Bumper Towing Capacity (pg. 288)	Kg (lbs)	907 (2,000)	907 (2,000)	907 (2,000)	907 (2,000)	907 (2,000)	907 (2,000)

WEIGHTS — HIGH ROOF, 2012 MODEL YEAR							
Item	Model Grade Engine	NV2500 S VQ40DE (4.0L)	NV2500 SV VQ40DE (4.0L)	NV2500 S VK56DE (5.6L)	NV2500 SV VK56DE (5.6L)	NV3500 S VK56DE (5.6L)	NV3500 SV VK56DE (5.6L)
Standard Payload	USA Kg (lbs)	1,325 (2,921.1)	1,300 (2,866)	1,300 (2,866)	1,250 (2,755.8)	1,650 (3,637.6)	1,625 (3,582.5)
	Canada Kg (lbs)	1,325 (2,921.1)	1,300 (2,866)	1,300 (2,866)	1,225 (2,700.7)	1,650 (3,637.6)	1,600 (3,527.4)
Rear GAWR	Kg (lbs)	2,665 (5,875)	2,665 (5,875)	2,665 (5,875)	2,665 (5,875)	2,760 (6,086)	2,760 (6,086)
Front GAWR	Kg (lbs)	1,735 (3,825)	1,735 (3,825)	1,735 (3,825)	1,735 (3,825)	1,735 (3,825)	1,735 (3,825)
Roof Load Maximum Weight Rating (pg. 333)	Kg (lbs)	136 (300)	136 (300)	136 (300)	136 (300)	136 (300)	136 (300)
Roof Bow Weld Nut Load Rating (pg. 332)	Kg (lbs)	4 (8.8) per pt. 30 (66) across all 10 pts.					
Bulkhead Roof Bow Weld Nut Load Rating (pg. 326)	Kg (lbs)	5 (11) per pt. 30 (66) across all 5 pts.					

WEIGHTS — HIGH ROOF, 2013–2014 MODEL YEARS

NOTE:

For Accessory Reserve Capacity (ARC), Center of Gravity (CG) or Unloaded Vehicle Weight (UVW) information, refer to [CENTER OF GRAVITY \(CG\) \(pg. 33\)](#).

NOTE:

All specifications are the same for USA, Canada and Mexico except where indicated.

WEIGHTS — HIGH ROOF, 2013–2014 MODEL YEARS							
Item	Model Grade Engine	NV2500 S VQ40DE (4.0L)	NV2500 SV VQ40DE (4.0L)	NV2500 S VK56DE (5.6L)	NV2500 SV VK56DE (5.6L)	NV3500 S VK56DE (5.6L)	NV3500 SV VK56DE (5.6L)
Rear Axle Ratio	—	3.36 : 1	3.36 : 1	3.54 : 1	3.54 : 1	3.54 : 1	3.54 : 1
Base Curb Weight - Total	USA Kg (lbs)	2,709.5 (5,974.4)	2,757.6 (6,080.5)	2,742.4 (6,047.0)	2,790.5 (6,153.1)	2,744.4 (6,051.4)	2,792.5 (6,157.5)
	Canada Kg (lbs)	2,716.4 (5,989.7)	2,765.1 (6,097.0)	2,774.3 (6,117.3)	2,832.3 (6,245.2)	2,751.3 (6,066.6)	2,834.3 (6,249.6)
	Mexico Kg (lbs)	2,742.5 (6,047.2)	—	2,777.4 (6,124.2)	—	—	—
Base Curb Weight - Rear	USA Kg (lbs)	1,303.8 (2,874.9)	1,342.1 (2,959.3)	1,303.8 (2,874.9)	1,346.6 (2,969.3)	1,309.3 (2,887.0)	1,347.6 (2,971.5)
	Canada Kg (lbs)	1,306.4 (2,880.6)	1,345.0 (2,966.0)	1,332.9 (2,939.0)	1,381.9 (3,047.1)	1,311.9 (2,892.7)	1,382.9 (3,049.3)
	Mexico Kg (lbs)	1,333.8 (2,941.0)	—	1,339.3 (2,953.2)	—	—	—
Base Curb Weight - Front	USA Kg (lbs)	1,405.7 (3,099.6)	1,415.5 (3,121.2)	1,434.1 (3,162.2)	1,443.9 (3,183.8)	1,435.1 (3,164.4)	1,444.9 (3,186.0)
	Canada Kg (lbs)	1,410.0 (3,109)	1,420.1 (3,131.3)	1,441.4 (3,178.3)	1,450.4 (3,298.1)	1,439.4 (3,173.9)	1,451.4 (3,200.3)
	Mexico Kg (lbs)	1,408.7 (3,106.2)	—	1,438.1 (3,171.0)	—	—	—
Maximum GCWR - With Factory Installed Tow Package	Kg (lbs)	—	—	7,257 (16,002)	7,257 (16,002)	7,257 (16,002)	7,257 (16,002)

WEIGHTS — HIGH ROOF, 2013–2014 MODEL YEARS							
Item	Model Grade Engine	NV2500 S VQ40DE (4.0L)	NV2500 SV VQ40DE (4.0L)	NV2500 S VK56DE (5.6L)	NV2500 SV VK56DE (5.6L)	NV3500 S VK56DE (5.6L)	NV3500 SV VK56DE (5.6L)
Maximum GCWR - Without Factory Installed Tow Package	Kg (lbs)	6,078 (13,402)	6,078 (13,402)	6,123 (13,501)	6,123 (13,501)	6,123 (13,501)	6,123 (13,501)
Maximum GVWR - Max. Pass., Plus Options and Cargo	USA Kg (lbs)	4,128 (9,102)	4,128 (9,102)	4,128 (9,102)	4,128 (9,102)	4,491 (9,902)	4,491 (9,902)
	Canada Kg (lbs)	4,128 (9,102)	4,128 (9,102)	4,128 (9,102)	4,128 (9,102)	4,491 (9,903)	4,491 (9,903)
Max. Tires and Load Rating @ 550kPa (80 psi) - Rear	Kg (lbs)	LT245/70R17 1,360 (3,000)	LT245/70R17 1,360 (3,000)	LT245/70R17 1,360 (3,000)	LT245/70R17 1,360 (3,000)	LT245/75R17 1,450 (3,197)	LT245/75R17 1,450 (3,197)
Max. Tires and Load Rating @ 350kPa (50 psi) - Front	Kg (lbs)	LT245/70R17 1,000 (2,205)	LT245/70R17 1,000 (2,205)	LT245/70R17 1,000 (2,205)	LT245/70R17 1,000 (2,205)	LT245/75R17 1,030 (2,271)	LT245/75R17 1,030 (2,271)
Maximum Factory Installed Tow Package Tongue Weight (pg. 288)	Kg (lbs)	430.9 (950)	430.9 (950)	430.9 (950)	430.9 (950)	430.9 (950)	430.9 (950)
Maximum Towing Capacity With Factory Installed Tow Package (pg. 288)	Kg (lbs)	4,309 (9,501)	4,309 (9,501)	4,309 (9,501)	4,309 (9,501)	4,309 (9,501)	4,309 (9,501)
Maximum Dealer Accessory Hitch Tongue Weight (pg. 288)	Kg (lbs)	317.5 (700)	317.5 (700)	317.5 (700)	317.5 (700)	317.5 (700)	317.5 (700)

WEIGHTS — HIGH ROOF, 2013–2014 MODEL YEARS							
Item	Model Grade Engine	NV2500 S VQ40DE (4.0L)	NV2500 SV VQ40DE (4.0L)	NV2500 S VK56DE (5.6L)	NV2500 SV VK56DE (5.6L)	NV3500 S VK56DE (5.6L)	NV3500 SV VK56DE (5.6L)
Maximum Towing Capacity With Dealer Accessory Hitch (pg. 288)	Kg (lbs)	3,175 (7,001)	3,175 (7,001)	3,175 (7,001)	3,175 (7,001)	3,175 (7,001)	3,175 (7,001)
Maximum Bumper Tongue Weight (pg. 288)	Kg (lbs)	90.7 (200)	90.7 (200)	90.7 (200)	90.7 (200)	90.7 (200)	90.7 (200)
Bumper Towing Capacity (pg. 288)	Kg (lbs)	907 (2,000)	907 (2,000)	907 (2,000)	907 (2,000)	907 (2,000)	907 (2,000)
Standard Payload	USA Kg (lbs)	1,325 (2,922)	1,300 (2,867)	1,300 (2,867)	1,250 (2,756)	1,650 (3,638)	1,625 (3,583)
	Canada Kg (lbs)	1,325 (2,922)	1,300 (2,867)	1,300 (2,867)	1,225 (2,701)	1,650 (3,638)	1,600 (3,528)
	Mexico Kg (lbs)	1,325 (2,922)	—	1,300 (2,867)	—	—	—
Rear GAWR	Kg (lbs)	2,665 (5,875)	2,665 (5,875)	2,665 (5,875)	2,665 (5,875)	2,760 (6,086)	2,760 (6,086)
Front GAWR	Kg (lbs)	1,735 (3,825)	1,735 (3,825)	1,735 (3,825)	1,735 (3,825)	1,735 (3,825)	1,735 (3,825)
Roof Load Maximum Weight Rating (pg. 333)	Kg (lbs)	136 (300)	136 (300)	136 (300)	136 (300)	136 (300)	136 (300)
Roof Bow Weld Nut Load Rating (pg. 332)	Kg (lbs)	4 (8.8) per pt. 30 (66) across all 10 pts.					
Bulkhead Roof Bow Weld Nut Load Rating (pg. 326)	Kg (lbs)	5 (11) per pt. 30 (66) across all 5 pts.					

138 WEIGHTS — HIGH ROOF, 2015-2016 MODEL YEARS

NOTE:
For Accessory Reserve Capacity (ARC), Center of Gravity (CG) or Unloaded Vehicle Weight (UVW) information, refer to [CENTER OF GRAVITY \(CG\) \(pg. 33\)](#).

NOTE:
All specifications are the same for USA, Canada and Mexico except where indicated.

WEIGHTS — HIGH ROOF, 2015-2016 MODEL YEARS										
Item	Model Grade Engine	NV2500 S VQ40DE (4.0L)	NV2500 SV VQ40DE (4.0L)	NV2500 SL VQ40DE (4.0L)	NV2500 S VK56DE (5.6L)	NV2500 SV VK56DE (5.6L)	NV2500 SL VK56DE (5.6L)	NV3500 S VK56DE (5.6L)	NV3500 SV VK56DE (5.6L)	NV3500 SL VK56DE (5.6L)
Rear Axle Ratio	—	3.36 : 1	3.36 : 1	3.36 : 1	3.54 : 1	3.54 : 1	3.54 : 1	3.54 : 1	3.54 : 1	3.54 : 1
Base Curb Weight - Total	USA Kg (lbs)	2,717 (5,990)	2,778 (6,124)	2,782 (6,133)	2,750 (6,063)	2,811 (6,197)	2,815 (6,206)	2,752 (6,070)	2,813 (6,202)	2,817 (6,210)
	Canada Kg (lbs)	2,738 (6,040)	2,787 (6,145)	—	2,732 (6,025)	2,815 (5,985)	—	2,734 (6,030)	2,817 (6,210)	—
	2015 Mexico Kg (lbs)	2,766 (6,100)	—	—	—	—	—	—	—	—
	2016 Mexico Kg (lbs)	2,765 (6,095)	—	—	—	—	—	—	—	—
Base Curb Weight - Rear	USA Kg (lbs)	1,309 (2,886)	1,352 (2,981)	1,353 (2,983)	1,313 (2,895)	1,356 (2,989)	1,358 (2,994)	1,314 (2,897)	1,357 (2,992)	1,359 (2,996)
	Canada Kg (lbs)	1,317 (2,905)	1,355 (2,990)	—	1,287 (2,840)	1,358 (2,995)	—	1,288 (2,840)	1,359 (2,995)	—
	2015 Mexico Kg (lbs)	1,345 (2,965)	—	—	—	—	—	—	—	—
	2016 Mexico Kg (lbs)	1,344 (2,965)	—	—	—	—	—	—	—	—

2012-2021 NV 1500/2500/3500 CARGO VAN

WEIGHTS — HIGH ROOF, 2015-2016 MODEL YEARS
[RESOURCE CHARTS]

WEIGHTS — HIGH ROOF, 2015-2016 MODEL YEARS

Item	Model Grade Engine	NV2500 S VQ40DE (4.0L)	NV2500 SV VQ40DE (4.0L)	NV2500 SL VQ40DE (4.0L)	NV2500 S VK56DE (5.6L)	NV2500 SV VK56DE (5.6L)	NV2500 SL VK56DE (5.6L)	NV3500 S VK56DE (5.6L)	NV3500 SV VK56DE (5.6L)	NV3500 SL VK56DE (5.6L)
Base Curb Weight - Front	USA Kg (lbs)	1,408 (3,104)	1,426 (3,144)	1,429 (3,150)	1,437 (3,168)	1,455 (3,208)	1,457 (3,212)	1,438 (3,170)	1,456 (3,210)	1,458 (3,214)
	Canada Kg (lbs)	1,422 (3,135)	1,432 (3,155)	—	1,445 (3,185)	1,457 (3,215)	—	1,446 (3,190)	1,458 (3,215)	—
	2015 Mexico Kg (lbs)	1,422 (3,135)	—	—	—	—	—	—	—	—
	2016 Mexico Kg (lbs)	1,421 (3,135)	—	—	—	—	—	—	—	—
Maximum GCWR - With Factory Installed Tow Package	Kg (lbs)	—	—	7,257 (16,002)	7,257 (16,002)	7,257 (16,002)	7,257 (16,002)	7,257 (16,002)	7,257 (16,002)	7,257 (16,002)
Maximum GCWR - Without Factory Installed Tow Package	Kg (lbs)	6,078 (13,402)	6,078 (13,402)	6,078 (13,402)	6,123 (13,501)	6,123 (13,501)	6,123 (13,501)	6,123 (13,501)	6,123 (13,501)	6,123 (13,501)
Maximum GVWR - Max. Pass., Plus Options and Cargo	USA Kg (lbs)	4,128 (9,100)	4,128 (9,100)	4,128 (9,100)	4,128 (9,100)	4,128 (9,100)	4,128 (9,100)	4,491 (9,900)	4,491 (9,900)	4,491 (9,900)
	Canada Kg (lbs)	4,128 (9,100)	4,128 (9,100)	—	4,128 (9,100)	4,128 (9,100)	—	4,491 (9,900)	4,491 (9,900)	—
	Mexico Kg (lbs)	4,128 (9,100)	—	—	—	—	—	—	—	—

WEIGHTS — HIGH ROOF, 2015-2016 MODEL YEARS

Item	Model Grade Engine	NV2500 S VQ40DE (4.0L)	NV2500 SV VQ40DE (4.0L)	NV2500 SL VQ40DE (4.0L)	NV2500 S VK56DE (5.6L)	NV2500 SV VK56DE (5.6L)	NV2500 SL VK56DE (5.6L)	NV3500 S VK56DE (5.6L)	NV3500 SV VK56DE (5.6L)	NV3500 SL VK56DE (5.6L)
Max. Tires and Load Rating @ 550kPa (80 psi) - Rear	Kg (lbs)	LT245/70R17 1,360 (3,000)	LT245/70R17 1,360 (3,000)	LT245/70R17 1,360 (3,000)	LT245/70R17 1,360 (3,000)	LT245/70R17 1,360 (3,000)	LT245/70R17 1,360 (3,000)	LT245/75R17 1,450 (3,197)	LT245/75R17 1,450 (3,197)	LT245/75R17 1,450 (3,197)
Max. Tires and Load Rating @ 350kPa (50 psi) - Front	Kg (lbs)	LT245/70R17 1,000 (2,205)	LT245/70R17 1,000 (2,205)	LT245/70R17 1,000 (2,205)	LT245/70R17 1,000 (2,205)	LT245/70R17 1,000 (2,205)	LT245/70R17 1,000 (2,205)	LT245/75R17 1,030 (2,271)	LT245/75R17 1,030 (2,271)	LT245/75R17 1,030 (2,271)
Maximum Factory Installed Tow Package Tongue Weight (pg. 288)	Kg (lbs)	430.9 (950)	430.9 (950)	430.9 (950)	430.9 (950)	430.9 (950)	430.9 (950)	430.9 (950)	430.9 (950)	430.9 (950)
Maximum Towing Capacity With Factory Installed Tow Package (pg. 288)	Kg (lbs)	4,309 (9,501)	4,309 (9,501)	4,309 (9,501)	4,309 (9,501)	4,309 (9,501)	4,309 (9,501)	4,309 (9,501)	4,309 (9,501)	4,309 (9,501)
Maximum Dealer Accessory Hitch Tongue Weight (pg. 288)	Kg (lbs)	317.5 (700)	317.5 (700)	317.5 (700)	317.5 (700)	317.5 (700)	317.5 (700)	317.5 (700)	317.5 (700)	317.5 (700)

WEIGHTS — HIGH ROOF, 2015-2016 MODEL YEARS

Item	Model Grade Engine	NV2500 S VQ40DE (4.0L)	NV2500 SV VQ40DE (4.0L)	NV2500 SL VQ40DE (4.0L)	NV2500 S VK56DE (5.6L)	NV2500 SV VK56DE (5.6L)	NV2500 SL VK56DE (5.6L)	NV3500 S VK56DE (5.6L)	NV3500 SV VK56DE (5.6L)	NV3500 SL VK56DE (5.6L)
Maximum Towing Capacity With Dealer Accessory Hitch (pg. 288)	Kg (lbs)	3,175 (7,001)	3,175 (7,001)	3,175 (7,001)	3,175 (7,001)	3,175 (7,001)	3,175 (7,001)	3,175 (7,001)	3,175 (7,001)	3,175 (7,001)
Maximum Bumper Tongue Weight (pg. 288)	Kg (lbs)	90.7 (200)	90.7 (200)	90.7 (200)	90.7 (200)	90.7 (200)	90.7 (200)	90.7 (200)	90.7 (200)	90.7 (200)
Bumper Towing Capacity (pg. 288)	Kg (lbs)	907 (2,000)	907 (2,000)	907 (2,000)	907 (2,000)	907 (2,000)	907 (2,000)	907 (2,000)	907 (2,000)	907 (2,000)
Standard Payload	USA Kg (lbs)	1,350 (2,976)	1,275 (2,810)	1,275 (2,810)	1,300 (2,866)	1,225 (2,700)	1,225 (2,700)	1,675 (3,692)	1,600 (3,527)	1,600 (3,527)
	Canada Kg (lbs)	1,325 (2,922)	1,300 (2,867)	—	1,300 (2,867)	1,225 (2,701)	—	1,650 (3,638)	1,600 (3,528)	—
	2015 Mexico Kg (lbs)	1,325 (2,922)	—	—	—	—	—	—	—	—
	2016 Mexico Kg (lbs)	1,338 (2,950)	—	—	—	—	—	—	—	—
Rear GAWR	Kg (lbs)	2,665 (5,875)	2,665 (5,875)	2,665 (5,875)	2,665 (5,875)	2,665 (5,875)	2,665 (5,875)	2,760 (6,086)	2,760 (6,086)	2,760 (6,086)
Front GAWR	Kg (lbs)	1,735 (3,825)	1,735 (3,825)	1,735 (3,825)	1,735 (3,825)	1,735 (3,825)	1,735 (3,825)	1,735 (3,825)	1,735 (3,825)	1,735 (3,825)

WEIGHTS — HIGH ROOF, 2015-2016 MODEL YEARS										
Item	Model Grade Engine	NV2500 S VQ40DE (4.0L)	NV2500 SV VQ40DE (4.0L)	NV2500 SL VQ40DE (4.0L)	NV2500 S VK56DE (5.6L)	NV2500 SV VK56DE (5.6L)	NV2500 SL VK56DE (5.6L)	NV3500 S VK56DE (5.6L)	NV3500 SV VK56DE (5.6L)	NV3500 SL VK56DE (5.6L)
Roof Load Maximum Weight Rating (pg. 333)	Kg (lbs)	136 (300)	136 (300)	136 (300)	136 (300)	136 (300)	136 (300)	136 (300)	136 (300)	136 (300)
Roof Bow Weld Nut Load Rating (pg. 332)	Kg (lbs)	4 (8.8) per pt. 30 (66) across all 10 pts.								
Bulkhead Roof Bow Weld Nut Load Rating (pg. 326)	Kg (lbs)	5 (11) per pt. 30 (66) across all 5 pts.								

WEIGHTS — HIGH ROOF, 2017 MODEL YEAR**NOTE:**

For Accessory Reserve Capacity (ARC), Center of Gravity (CG) or Unloaded Vehicle Weight (UVW) information, refer to [CENTER OF GRAVITY \(CG\) \(pg. 33\)](#).

NOTE:

All specifications are the same for USA, Canada and Mexico except where indicated.

WEIGHTS — HIGH ROOF, 2017 MODEL YEAR										
Item	Model Grade Engine	NV2500 S VQ40DE (4.0L)	NV2500 SV VQ40DE (4.0L)	NV2500 SL VQ40DE (4.0L)	NV2500 S VK56VD (5.6L)	NV2500 SV VK56VD (5.6L)	NV2500 SL VK56VD (5.6L)	NV3500 S VK56VD (5.6L)	NV3500 SV VK56VD (5.6L)	NV3500 SL VK56VD (5.6L)
Rear Axle Ratio	—	3.36 : 1			3.54 : 1					
Base Curb Weight - Total	USA Kg (lbs)	2,708 (5,971)	2,773 (6,113)	2,780 (6,128)	2,806 (6,186)	2,870 (6,328)	2,877 (6,343)	2,809 (6,194)	2,874 (6,336)	2,881 (6,351)
	Canada Kg (lbs)	2,733 (6,025)	2,782 (6,133)	—	2,792 (6,155)	2,877 (6,342)	—	2,797 (6,166)	2,884 (6,358)	—
Base Curb Weight - Rear	USA Kg (lbs)	1,305 (2,878)	1,351 (2,977)	1,354 (2,984)	1,347 (2,969)	1,391 (3,068)	1,394 (3,074)	1,348 (2,972)	1,393 (3,072)	1,396 (3,078)
	Canada Kg (lbs)	1,316 (2,900)	1,354 (2,986)	—	1,322 (2,915)	1,394 (3,074)	—	1,325 (2,920)	1,397 (3,081)	—
Base Curb Weight - Front	USA Kg (lbs)	1,403 (3,093)	1,422 (3,136)	1,426 (3,144)	1,459 (3,218)	1,479 (3,260)	1,483 (3,269)	1,461 (3,222)	1,481 (3,264)	1,485 (3,273)
	Canada Kg (lbs)	1,417 (3,125)	1,428 (3,147)	—	1,469 (3,239)	1,482 (3,268)	—	1,472 (3,245)	1,487 (3,278)	—
Maximum GCWR	Kg (lbs)	6,078 (13,400)			7,257 (16,000)					
Maximum GVWR - Max. Pass., Plus Options and Cargo	USA Kg (lbs)	4,128 (9,100)						4,491 (9,900)		
	Canada Kg (lbs)	4,128 (9,100)	—	4,128 (9,100)	—	4,491 (9,900)	—	—	—	—

WEIGHTS — HIGH ROOF, 2017 MODEL YEAR										
Item	Model Grade Engine	NV2500 S VQ40DE (4.0L)	NV2500 SV VQ40DE (4.0L)	NV2500 SL VQ40DE (4.0L)	NV2500 S VK56VD (5.6L)	NV2500 SV VK56VD (5.6L)	NV2500 SL VK56VD (5.6L)	NV3500 S VK56VD (5.6L)	NV3500 SV VK56VD (5.6L)	NV3500 SL VK56VD (5.6L)
Max. Tires and Load Rating @ 550kPa (80 psi) - Rear	Kg (lbs)	LT245/70R17 1,360 (3,000)						LT245/75R17 1,450 (3,197)		
Max. Tires and Load Rating @ 350kPa (50 psi) - Front	Kg (lbs)	LT245/70R17 1,000 (2,205)						LT245/75R17 1,030 (2,271)		
Maximum Factory Installed Tow Package Tongue Weight (pg. 288)	USA Kg (lbs)	—			426 (940)					
	Canada Kg (lbs)	313 (690)	—		426 (940)	—		426 (940)	—	
Maximum Towing Capacity With Factory Installed Tow Package (pg. 288)	USA Kg (lbs)	—			4,264 (9,400)					
	Canada Kg (lbs)	3,130 (6,900)	—		4,264 (9,400)	—		4,264 (9,400)	—	
Maximum Dealer Accessory Hitch Tongue Weight (pg. 288)	USA only Kg (lbs)	313 (690)			—					

WEIGHTS — HIGH ROOF, 2017 MODEL YEAR										
Item	Model Grade Engine	NV2500 S VQ40DE (4.0L)	NV2500 SV VQ40DE (4.0L)	NV2500 SL VQ40DE (4.0L)	NV2500 S VK56VD (5.6L)	NV2500 SV VK56VD (5.6L)	NV2500 SL VK56VD (5.6L)	NV3500 S VK56VD (5.6L)	NV3500 SV VK56VD (5.6L)	NV3500 SL VK56VD (5.6L)
Maximum Towing Capacity With Dealer Accessory Hitch (pg. 288)	USA only Kg (lbs)	3,130 (6,900)			—					
Maximum Bumper Tongue Weight (pg. 288)	Kg (lbs)	90.7 (200)								
Bumper Towing Capacity (pg. 288)	Kg (lbs)	907 (2,000)								
Standard Payload	USA Kg (lbs)	1,350 (2,976)	1,300 (2,866)	1,300 (2,866)	1,275 (2,811)	1,225 (2,701)	1,200 (2,646)	1,625 (3,583)	1,575 (3,472)	1,575 (3,472)
	Canada Kg (lbs)	1,350 (2,976)	1,275 (2,811)	—	1,300 (2,866)	1,200 (2,646)	—	1,650 (3,638)	1,575 (3,472)	—
Rear GAWR	Kg (lbs)	2,665 (5,875)						2,760 (6,085)		
Front GAWR	Kg (lbs)	1,735 (3,825)								
Roof Load Maximum Weight Rating (pg. 333)	Kg (lbs)	136 (300)								
Roof Bow Weld Nut Load Rating (pg. 332)	Kg (lbs)	4 (8.8) per pt. 30 (66) across all 10 pts.								

WEIGHTS — HIGH ROOF, 2017 MODEL YEAR										
Item	Model Grade Engine	NV2500 S VQ40DE (4.0L)	NV2500 SV VQ40DE (4.0L)	NV2500 SL VQ40DE (4.0L)	NV2500 S VK56VD (5.6L)	NV2500 SV VK56VD (5.6L)	NV2500 SL VK56VD (5.6L)	NV3500 S VK56VD (5.6L)	NV3500 SV VK56VD (5.6L)	NV3500 SL VK56VD (5.6L)
Bulkhead Roof Bow Weld Nut Load Rating (pg. 326)	Kg (lbs)	<p>5 (11) per pt. 30 (66) across all 5 pts.</p>								

WEIGHTS — HIGH ROOF, 2018 MODEL YEAR**NOTE:**

For Accessory Reserve Capacity (ARC), Center of Gravity (CG) or Unloaded Vehicle Weight (UVW) information, refer to [CENTER OF GRAVITY \(CG\) \(pg. 33\)](#).

NOTE:

All specifications are the same for USA, Canada and Mexico except where indicated.

WEIGHTS — HIGH ROOF, 2018 MODEL YEAR										
Item	Model Grade Engine	NV2500 S VQ40DE (4.0L)	NV2500 SV VQ40DE (4.0L)	NV2500 SL VQ40DE (4.0L)	NV2500 S VK56VD (5.6L)	NV2500 SV VK56VD (5.6L)	NV2500 SL VK56VD (5.6L)	NV3500 S VK56VD (5.6L)	NV3500 SV VK56VD (5.6L)	NV3500 SL VK56VD (5.6L)
Rear Axle Ratio	—	3.36 : 1			3.54 : 1					
Base Curb Weight - Total	USA Kg (lbs)	2,713.4 (5,982.1)	2,776.0 (6,120.1)	2,782.5 (6,134.4)	2,811.0 (6,197.1)	2,873.4 (6,334.7)	2,879.8 (6,348.8)	2,814.4 (6,204.6)	2,877.0 (6,342.6)	2,883.4 (6,356.7)
	Canada Kg (lbs)	2,738.2 (6,036.7)	2,785.0 (6,139.9)	—	2,796.8 (6,165.8)	2,879.8 (6,348.8)	—	2,801.6 (6,176.4)	2,887.2 (6,365.1)	—
Base Curb Weight - Rear	USA Kg (lbs)	1,306.9 (2,881.2)	1,351.0 (2,978.4)	1,353.7 (2,984.3)	1,348.1 (2,972.0)	1,391.9 (3,068.6)	1,394.6 (3,074.5)	1,349.6 (2,975.3)	1,393.7 (3,072.6)	1,396.4 (3,078.5)
	Canada Kg (lbs)	1,317.2 (2,903.9)	1,354.7 (2,986.6)	—	1,324.0 (2,918.9)	1,394.7 (3,074.8)	—	1,326.2 (2,923.8)	1,397.8 (3,081.6)	—
Base Curb Weight - Front	USA Kg (lbs)	1,406.5 (3,100.9)	1,425.0 (3,141.7)	1,428.8 (3,150.1)	1,462.9 (3,225.1)	1,481.5 (3,266.1)	1,485.2 (3,274.2)	1,464.8 (3,229.2)	1,483.3 (3,270.0)	1,487.0 (3,278.2)
	Canada Kg (lbs)	1,421.0 (3,132.9)	1,430.3 (3,153.4)	—	1,472.8 (3,246.9)	1,485.1 (3,274.0)	—	1,475.4 (3,252.6)	1,489.4 (3,283.5)	—
Maximum GCWR	Kg (lbs)	6,078 (13,400)			6,078 (13,400)			7,257 (16,000)		
Maximum GVWR - Max. Pass., Plus Options and Cargo	USA Kg (lbs)	4,128 (9,100)						4,491 (9,900)		
	Canada Kg (lbs)	4,128 (9,100)	—	—	4,128 (9,100)	—	—	4,491 (9,900)	—	—

WEIGHTS — HIGH ROOF, 2018 MODEL YEAR										
Item	Model Grade Engine	NV2500 S VQ40DE (4.0L)	NV2500 SV VQ40DE (4.0L)	NV2500 SL VQ40DE (4.0L)	NV2500 S VK56VD (5.6L)	NV2500 SV VK56VD (5.6L)	NV2500 SL VK56VD (5.6L)	NV3500 S VK56VD (5.6L)	NV3500 SV VK56VD (5.6L)	NV3500 SL VK56VD (5.6L)
Max. Tires and Load Rating @ 550kPa (80 psi) - Rear	Kg (lbs)	LT245/70R17 1,360 (3,000)						LT245/75R17 1,450 (3,197)		
Max. Tires and Load Rating @ 350kPa (50 psi) - Front	Kg (lbs)	LT245/70R17 1,000 (2,205)						LT245/75R17 1,030 (2,271)		
Maximum Factory Installed Tow Package Tongue Weight (pg. 288)	USA Kg (lbs)	—			426 (940)					
	Canada Kg (lbs)	313 (690)	—		426 (940)	—		426 (940)	—	
Maximum Towing Capacity With Factory Installed Tow Package (pg. 288)	USA Kg (lbs)	—			4,264 (9,400)					
	Canada Kg (lbs)	3,130 (6,900)	—		4,264 (9,400)	—		4,264 (9,400)	—	
Maximum Dealer Accessory Hitch Tongue Weight (pg. 288)	USA only Kg (lbs)	313 (690)			—					

WEIGHTS — HIGH ROOF, 2018 MODEL YEAR										
Item	Model Grade Engine	NV2500 S VQ40DE (4.0L)	NV2500 SV VQ40DE (4.0L)	NV2500 SL VQ40DE (4.0L)	NV2500 S VK56VD (5.6L)	NV2500 SV VK56VD (5.6L)	NV2500 SL VK56VD (5.6L)	NV3500 S VK56VD (5.6L)	NV3500 SV VK56VD (5.6L)	NV3500 SL VK56VD (5.6L)
Maximum Towing Capacity With Dealer Accessory Hitch (pg. 288)	USA only Kg (lbs)	3,130 (6,900)			—					
Maximum Bumper Tongue Weight (pg. 288)	Kg (lbs)	91 (200)								
Bumper Towing Capacity (pg. 288)	Kg (lbs)	907 (2,000)								
Standard Payload	USA Kg (lbs)	1,411 (3,110)	1,352 (2,980)	1,343 (2,960)	1,315 (2,900)	1,252 (2,760)	1,247 (2,750)	1,674 (3,690)	1,610 (3,550)	1,606 (3,540)
	Canada Kg (lbs)	1,388 (3,060)	1,343 (2,960)	—	1,329 (2,930)	1,247 (2,750)	—	1,687 (3,720)	1,601 (3,530)	—
Rear GAWR	Kg (lbs)	2,665 (5,875)						2,760 (6,085)		
Front GAWR	Kg (lbs)	1,735 (3,825)								
Roof Load Maximum Weight Rating (pg. 333)	Kg (lbs)	136 (300)								
Roof Bow Weld Nut Load Rating (pg. 332)	Kg (lbs)	4 (8.8) per pt. 30 (66) across all 10 pts.								

WEIGHTS — HIGH ROOF, 2018 MODEL YEAR										
Item	Model Grade Engine	NV2500 S VQ40DE (4.0L)	NV2500 SV VQ40DE (4.0L)	NV2500 SL VQ40DE (4.0L)	NV2500 S VK56VD (5.6L)	NV2500 SV VK56VD (5.6L)	NV2500 SL VK56VD (5.6L)	NV3500 S VK56VD (5.6L)	NV3500 SV VK56VD (5.6L)	NV3500 SL VK56VD (5.6L)
Bulkhead Roof Bow Weld Nut Load Rating (pg. 326)	Kg (lbs)	<p>5 (11) per pt. 30 (66) across all 5 pts.</p>								

WEIGHTS — HIGH ROOF, 2019 MODEL YEAR

NOTE:

For Accessory Reserve Capacity (ARC), Center of Gravity (CG) or Unloaded Vehicle Weight (UVW) information, refer to [CENTER OF GRAVITY \(CG\) \(pg. 33\)](#).

NOTE:

All specifications are the same for USA, Canada and Mexico except where indicated.

WEIGHTS — HIGH ROOF, 2019 MODEL YEAR											
Item	Model Grade Engine	NV2500 S VQ40DE (4.0L)	NV2500 SV VQ40DE (4.0L)	NV2500 SL VQ40DE (4.0L)	NV2500 S VK56VD (5.6L)	NV2500 SV VK56VD (5.6L)	NV2500 SL VK56VD (5.6L)	NV3500 S VK56VD (5.6L)	NV3500 SV VK56VD (5.6L)	NV3500 SL VK56VD (5.6L)	
Rear Axle Ratio	—	3.36 : 1			3.54 : 1						
Base Curb Weight - Total	USA Kg (lbs)	2,713.5 (5,982.1)	2,776.1 (6,120.1)	2,782.6 (6,134.5)	2,811.0 (6,197.2)	2,873.4 (6,334.7)	2,879.8 (6,348.8)	2,814.4 (6,204.6)	2,877.0 (6,342.7)	2,883.4 (6,356.8)	
	Canada Kg (lbs)	2,738.9 (6,038.1)	2,785.8 (6,141.5)	—	2,797.4 (6,167.2)	2,880.4 (6,350.2)	—	2,802.4 (6,178.2)	2,887.8 (6,366.5)	—	
Base Curb Weight - Rear	USA Kg (lbs)	1,306.9 (2,881.2)	1,351.0 (2,978.4)	1,353.7 (2,984.4)	1,348.1 (2,972.1)	1,391.9 (3,068.6)	1,394.6 (3,074.6)	1,349.6 (2,975.4)	1,393.7 (3,072.6)	1,396.4 (3,078.6)	
	Canada Kg (lbs)	1,317.5 (2,904.6)	1,355.0 (2,987.2)	—	1,324.3 (2,919.6)	1,395.0 (3,075.5)	—	1,326.6 (2,924.7)	1,398.1 (3,082.3)	—	
Base Curb Weight - Front	USA Kg (lbs)	1,406.6 (3,100.9)	1,425.1 (3,141.7)	1,428.9 (3,150.1)	1,462.9 (3,225.1)	1,481.5 (3,266.1)	1,485.2 (3,274.2)	1,464.8 (3,229.3)	1,483.3 (3,270.1)	1,487.0 (3,278.2)	
	Canada Kg (lbs)	1,421.4 (3,133.6)	1,430.8 (3,154.3)	—	1,473.1 (3,274.6)	1,485.4 (3,274.7)	—	1,475.8 (3,253.5)	1,489.7 (3,284.2)	—	
Maximum GCWR	USA Kg (lbs)	6,078 (13,400)			6,123 (13,500)			7,257 (16,000)			
	Canada Kg (lbs)	6,078 (13,400)		—	6,123 (13,500)		—	7,257 (16,000)		—	
Maximum GVWR - Max. Pass., Plus Options and Cargo	USA Kg (lbs)	4,128 (9,100)						4,491 (9,900)			
	Canada Kg (lbs)	4,128 (9,100)		—	4,128 (9,100)		—	4,491 (9,900)		—	

WEIGHTS — HIGH ROOF, 2019 MODEL YEAR										
Item	Model Grade Engine	NV2500 S VQ40DE (4.0L)	NV2500 SV VQ40DE (4.0L)	NV2500 SL VQ40DE (4.0L)	NV2500 S VK56VD (5.6L)	NV2500 SV VK56VD (5.6L)	NV2500 SL VK56VD (5.6L)	NV3500 S VK56VD (5.6L)	NV3500 SV VK56VD (5.6L)	NV3500 SL VK56VD (5.6L)
Max. Tires and Load Rating @ 550kPa (80 psi) - Rear	Kg (lbs)	LT245/70R17 1,360 (3,000)						LT245/75R17 1,450 (3,197)		
Max. Tires and Load Rating @ 350kPa (50 psi) - Front	Kg (lbs)	LT245/70R17 1,000 (2,205)						LT245/75R17 1,030 (2,271)		
Maximum Factory Installed Tow Package Tongue Weight (pg. 288)	USA Kg (lbs)	—			426 (940)					
	Canada Kg (lbs)	313 (690)	—		426 (940)	—		426 (940)	—	
Maximum Towing Capacity With Factory Installed Tow Package (pg. 288)	USA Kg (lbs)	—			4,264 (9,400)					
	Canada Kg (lbs)	3,130 (6,900)	—		4,264 (9,400)	—		4,264 (9,400)	—	
Maximum Dealer Accessory Hitch Tongue Weight (pg. 288)	USA only Kg (lbs)	313 (690)			—					

WEIGHTS — HIGH ROOF, 2019 MODEL YEAR										
Item	Model Grade Engine	NV2500 S VQ40DE (4.0L)	NV2500 SV VQ40DE (4.0L)	NV2500 SL VQ40DE (4.0L)	NV2500 S VK56VD (5.6L)	NV2500 SV VK56VD (5.6L)	NV2500 SL VK56VD (5.6L)	NV3500 S VK56VD (5.6L)	NV3500 SV VK56VD (5.6L)	NV3500 SL VK56VD (5.6L)
Maximum Towing Capacity With Dealer Accessory Hitch (pg. 288)	USA only Kg (lbs)	3,130 (6,900)			—					
Maximum Bumper Tongue Weight (pg. 288)	Kg (lbs)	91 (200)								
Bumper Towing Capacity (pg. 288)	Kg (lbs)	907 (2,000)								
Standard Payload	USA Kg (lbs)	1,411 (3,110)	1,352 (2,980)	1,343 (2,960)	1,315 (2,900)	1,252 (2,760)	1,247 (2,750)	1,674 (3,690)	1,610 (3,550)	1,606 (3,540)
	Canada Kg (lbs)	1,388 (3,060)	1,302 (2,870)	—	1,329 (2,930)	1,247 (2,750)	—	1,687 (3,720)	1,601 (3,530)	—
Rear GAWR	Kg (lbs)	2,665 (5,875)						2,760 (6,085)		
Front GAWR	Kg (lbs)	1,735 (3,825)								
Roof Load Maximum Weight Rating (pg. 333)	Kg (lbs)	136 (300)								
Roof Bow Weld Nut Load Rating (pg. 332)	Kg (lbs)	4 (8.8) per pt. 30 (66) across all 10 pts.								

WEIGHTS — HIGH ROOF, 2019 MODEL YEAR										
Item	Model Grade Engine	NV2500 S VQ40DE (4.0L)	NV2500 SV VQ40DE (4.0L)	NV2500 SL VQ40DE (4.0L)	NV2500 S VK56VD (5.6L)	NV2500 SV VK56VD (5.6L)	NV2500 SL VK56VD (5.6L)	NV3500 S VK56VD (5.6L)	NV3500 SV VK56VD (5.6L)	NV3500 SL VK56VD (5.6L)
Bulkhead Roof Bow Weld Nut Load Rating (pg. 326)	Kg (lbs)	<p>5 (11) per pt. 30 (66) across all 5 pts.</p>								

WEIGHTS — HIGH ROOF, 2020 MODEL YEAR

NOTE:

For Accessory Reserve Capacity (ARC), Center of Gravity (CG) or Unloaded Vehicle Weight (UVW) information, refer to [CENTER OF GRAVITY \(CG\) \(pg. 33\)](#).

NOTE:

All specifications are the same for USA, Canada and Mexico except where indicated.

WEIGHTS — HIGH ROOF, 2020 MODEL YEAR										
Item	Model Grade Engine	NV2500 S VQ40DE (4.0L)	NV2500 SV VQ40DE (4.0L)	NV2500 SL VQ40DE (4.0L)	NV2500 S VK56VD (5.6L)	NV2500 SV VK56VD (5.6L)	NV2500 SL VK56VD (5.6L)	NV3500 S VK56VD (5.6L)	NV3500 SV VK56VD (5.6L)	NV3500 SL VK56VD (5.6L)
Rear Axle Ratio	—	3.36 : 1			3.54 : 1					
Base Curb Weight - Total	USA Kg (lbs)	2,713.4 (5,982.1)	2,776.0 (6,120.1)	2,782.5 (6,134.4)	2,811.0 (6,197.2)	2,873.4 (6,334.7)	2,879.8 (6,348.8)	2,814.4 (6,204.6)	2,877.0 (6,342.7)	2,883.4 (6,356.8)
	Canada Kg (lbs)	2,738.8 (6,038.1)	2,824.4 (6,226.8)	—	2,797.4 (6,167.2)	2,880.4 (6,350.2)	—	2,802.4 (6,178.2)	2,887.8 (6,366.5)	—
Base Curb Weight - Rear	USA Kg (lbs)	1,306.9 (2,881.2)	1,351.0 (2,978.4)	1,353.7 (2,984.3)	1,348.1 (2,972.1)	1,391.9 (3,068.6)	1,394.6 (3,074.6)	1,349.6 (2,975.4)	1,393.7 (3,072.6)	1,396.4 (3,078.6)
	Canada Kg (lbs)	1,317.5 (2,904.5)	1,389.1 (3,062.4)	—	1,324.3 (2,919.6)	1,395.0 (3,075.5)	—	1,326.6 (2,924.7)	1,398.1 (3,082.3)	—
Base Curb Weight - Front	USA Kg (lbs)	1,406.6 (3,100.9)	1,425.1 (3,141.7)	1,428.9 (3,150.1)	1,462.9 (3,225.1)	1,481.5 (3,266.1)	1,485.2 (3,274.2)	1,464.8 (3,229.3)	1,483.3 (3,270.1)	1,487.0 (3,278.2)
	Canada Kg (lbs)	1,421.4 (3,133.6)	1,435.4 (3,164.4)	—	1,473.1 (3,274.6)	1,485.4 (3,274.7)	—	1,475.8 (3,253.5)	1,489.7 (3,284.2)	—
Maximum GCWR	USA Kg (lbs)	6,078 (13,400)			6,123 (13,500)			7,257 (16,000)		
	Canada Kg (lbs)	6,078 (13,400)		—	6,123 (13,500)		—	7,257 (16,000)		—
Maximum GVWR - Max. Pass., Plus Options and Cargo	USA Kg (lbs)	4,128 (9,100)						4,491 (9,900)		
	Canada Kg (lbs)	4,128 (9,100)		—	4,128 (9,100)		—	4,491 (9,900)		—

WEIGHTS — HIGH ROOF, 2020 MODEL YEAR										
Item	Model Grade Engine	NV2500 S VQ40DE (4.0L)	NV2500 SV VQ40DE (4.0L)	NV2500 SL VQ40DE (4.0L)	NV2500 S VK56VD (5.6L)	NV2500 SV VK56VD (5.6L)	NV2500 SL VK56VD (5.6L)	NV3500 S VK56VD (5.6L)	NV3500 SV VK56VD (5.6L)	NV3500 SL VK56VD (5.6L)
Max. Tires and Load Rating @ 550kPa (80 psi) - Rear	Kg (lbs)	LT245/70R17 1,360 (3,000)						LT245/75R17 1,450 (3,197)		
Max. Tires and Load Rating @ 350kPa (50 psi) - Front	Kg (lbs)	LT245/70R17 1,000 (2,205)						LT245/75R17 1,030 (2,271)		
Maximum Factory Installed Tow Package Tongue Weight (pg. 288)	USA Kg (lbs)	—			426 (940)					
	Canada Kg (lbs)	313 (690)	—		426 (940)	—		426 (940)	—	
Maximum Towing Capacity With Factory Installed Tow Package (pg. 288)	USA Kg (lbs)	—			4,264 (9,400)					
	Canada Kg (lbs)	3,130 (6,900)	—		4,264 (9,400)	—		4,264 (9,400)	—	
Maximum Dealer Accessory Hitch Tongue Weight (pg. 288)	USA only Kg (lbs)	313 (690)			—					

WEIGHTS — HIGH ROOF, 2020 MODEL YEAR										
Item	Model Grade Engine	NV2500 S VQ40DE (4.0L)	NV2500 SV VQ40DE (4.0L)	NV2500 SL VQ40DE (4.0L)	NV2500 S VK56VD (5.6L)	NV2500 SV VK56VD (5.6L)	NV2500 SL VK56VD (5.6L)	NV3500 S VK56VD (5.6L)	NV3500 SV VK56VD (5.6L)	NV3500 SL VK56VD (5.6L)
Maximum Towing Capacity With Dealer Accessory Hitch (pg. 288)	USA only Kg (lbs)	3,130 (6,900)			—					
Maximum Bumper Tongue Weight (pg. 288)	Kg (lbs)	91 (200)								
Bumper Towing Capacity (pg. 288)	Kg (lbs)	907 (2,000)								
Standard Payload	USA Kg (lbs)	1,411 (3,110)	1,352 (2,980)	1,343 (2,960)	1,315 (2,900)	1,252 (2,760)	1,247 (2,750)	1,674 (3,690)	1,610 (3,550)	1,606 (3,540)
	Canada Kg (lbs)	1,388 (3,060)	1,302 (2,870)	—	1,329 (2,930)	1,247 (2,750)	—	1,687 (3,720)	1,601 (3,530)	—
Rear GAWR	Kg (lbs)	2,665 (5,875)						2,760 (6,085)		
Front GAWR	Kg (lbs)	1,735 (3,825)								
Roof Load Maximum Weight Rating (pg. 333)	Kg (lbs)	136 (300)								
Roof Bow Weld Nut Load Rating (pg. 332)	Kg (lbs)	4 (8.8) per pt. 30 (66) across all 10 pts.								

WEIGHTS — HIGH ROOF, 2020 MODEL YEAR										
Item	Model Grade Engine	NV2500 S VQ40DE (4.0L)	NV2500 SV VQ40DE (4.0L)	NV2500 SL VQ40DE (4.0L)	NV2500 S VK56VD (5.6L)	NV2500 SV VK56VD (5.6L)	NV2500 SL VK56VD (5.6L)	NV3500 S VK56VD (5.6L)	NV3500 SV VK56VD (5.6L)	NV3500 SL VK56VD (5.6L)
Bulkhead Roof Bow Weld Nut Load Rating (pg. 326)	Kg (lbs)	<p>5 (11) per pt. 30 (66) across all 5 pts.</p>								

WEIGHTS — HIGH ROOF, 2021 MODEL YEAR

NOTE:

For Accessory Reserve Capacity (ARC), Center of Gravity (CG) or Unloaded Vehicle Weight (UVW) information, refer to [CENTER OF GRAVITY \(CG\) \(pg. 33\)](#).

NOTE:

All specifications are the same for USA, Canada and Mexico except where indicated.

WEIGHTS — HIGH ROOF, 2021 MODEL YEAR								
Item	Model Grade Engine	NV2500 S VQ40DE (4.0L)	NV2500 SV VQ40DE (4.0L)	NV2500 S VK56VD (5.6L)	NV2500 SV VK56VD (5.6L)	NV3500 S VK56VD (5.6L)	NV3500 SV VK56VD (5.6L)	NV3500 SL VK56VD (5.6L)
Rear Axle Ratio	—	3.36 : 1		3.54 : 1				
Base Curb Weight - Total	USA Kg (lbs)	2,714.6 (5,984.6)	2,777.2 (6,122.6)	—	2,874.5 (6,337.2)	—	2,878.1 (6,345.1)	2,884.5 (6,359.2)
	Canada Kg (lbs)	2,740.1 (6,040.8)	2,826.2 (6,230.6)	2,798.6 (6,169.9)	2,881.6 (6,352.9)	2,803.5 (6,180.7)	2,889.0 (6,369.2)	—
Base Curb Weight - Rear	USA Kg (lbs)	1,307.0 (2,881.4)	1,351.1 (2,978.6)	—	1,392.0 (3,068.9)	—	1,393.8 (3,072.8)	1,396.5 (3,078.8)
	Canada Kg (lbs)	1,317.6 (2,904.8)	1,389.2 (3,062.6)	1,324.4 (2,919.8)	1,395.1 (3,075.7)	1,326.7 (2,924.9)	1,398.2 (3,082.5)	—
Base Curb Weight - Front	USA Kg (lbs)	1,407.6 (3,103.2)	1,426.1 (3,144.0)	—	1,482.5 (3,268.3)	—	1,484.3 (3,272.3)	1,488.0 (3,280.5)
	Canada Kg (lbs)	1,422.5 (3,136.0)	1,437.0 (3,168.0)	1,474.2 (3,251.0)	1,486.5 (3,277.2)	1,476.8 (3,255.8)	1,490.8 (3,286.6)	—
Maximum GCWR	USA Kg (lbs)	6,078 (13,400)		7,257 (16,000)		7,257 (16,000)		
	Canada Kg (lbs)					7,257 (16,000)		—
Maximum GVWR - Max. Pass., Plus Options and Cargo	USA Kg (lbs)	4,128 (9,100)				4,491 (9,900)		
	Canada Kg (lbs)	4,128 (9,100)		4,128 (9,100)		4,491 (9,900)		—

WEIGHTS — HIGH ROOF, 2021 MODEL YEAR								
Item	Model Grade Engine	NV2500 S VQ40DE (4.0L)	NV2500 SV VQ40DE (4.0L)	NV2500 S VK56VD (5.6L)	NV2500 SV VK56VD (5.6L)	NV3500 S VK56VD (5.6L)	NV3500 SV VK56VD (5.6L)	NV3500 SL VK56VD (5.6L)
Max. Tires and Load Rating @ 550kPa (80 psi) - Rear	Kg (lbs)	LT245/70R17 1,360 (3,000)				LT245/75R17 1,450 (3,197)		
Max. Tires and Load Rating @ 350kPa (50 psi) - Front	Kg (lbs)	LT245/70R17 1,000 (2,205)				LT245/75R17 1,030 (2,271)		
Maximum Factory Installed Tow Package Tongue Weight (pg. 288)	USA Kg (lbs)	—		426 (940)				
	Canada Kg (lbs)	313 (690)	—	426 (940)		426 (940)		—
Maximum Towing Capacity With Factory Installed Tow Package (pg. 288)	USA Kg (lbs)	—		4,264 (9,400)				
	Canada Kg (lbs)	3,130 (6,900)	—	4,264 (9,400)		4,264 (9,400)		—
Maximum Dealer Accessory Hitch Tongue Weight (pg. 288)	USA only Kg (lbs)	313 (690)		—				

WEIGHTS — HIGH ROOF, 2021 MODEL YEAR								
Item	Model Grade Engine	NV2500 S VQ40DE (4.0L)	NV2500 SV VQ40DE (4.0L)	NV2500 S VK56VD (5.6L)	NV2500 SV VK56VD (5.6L)	NV3500 S VK56VD (5.6L)	NV3500 SV VK56VD (5.6L)	NV3500 SL VK56VD (5.6L)
Maximum Towing Capacity With Dealer Accessory Hitch (pg. 288)	USA only Kg (lbs)	3,130 (6,900)			—			
Maximum Bumper Tongue Weight (pg. 288)	Kg (lbs)	91 (200)						
Bumper Towing Capacity (pg. 288)	Kg (lbs)	907 (2,000)						
Standard Payload	USA Kg (lbs)	1,411 (3,110)	1,347 (2,970)	—	1,252 (2,760)	—	1,610 (3,550)	1,606 (3,540)
	Canada Kg (lbs)	1,383 (3,050)	1,302 (2,870)	1,329 (2,930)	1,243 (2,740)	1,687 (3,720)	1,601 (3,530)	—
Rear GAWR	Kg (lbs)	2,665 (5,875)				2,760 (6,085)		
Front GAWR	Kg (lbs)	1,735 (3,825)						
Roof Load Maximum Weight Rating (pg. 333)	Kg (lbs)	136 (300)						
Roof Bow Weld Nut Load Rating (pg. 332)	Kg (lbs)	4 (8.8) per pt. 30 (66) across all 10 pts.						
Bulkhead Roof Bow Weld Nut Load Rating (pg. 326)	Kg (lbs)	5 (11) per pt. 30 (66) across all 5 pts.						

162 INTERIOR MEASUREMENTS — HIGH ROOF

NOTE:

All specifications are the same for USA, Canada and Mexico except where indicated.

INTERIOR MEASUREMENTS — HIGH ROOF							
Item	Model Grade Engine	NV2500 S V6 Engine	NV2500 SV/SL* V6 Engine	NV2500 S V8 Engine	NV2500 SV/SL* V8 Engine	NV3500 S V8 Engine	NV3500 SV/SL* V8 Engine
Maximum Cargo Width at Wheel Wells (pg. 176)	mm (in)	1,378 (54.25)	1,378 (54.25)	1,378 (54.25)	1,378 (54.25)	1,378 (54.25)	1,378 (54.25)
Maximum Cargo Width at Floor Rear (pg. 176)	mm (in)	1,783 (70.2)	1,783 (70.2)	1,783 (70.2)	1,783 (70.2)	1,783 (70.2)	1,783 (70.2)
Maximum Cargo Width Between C-pillars (pg. 176)	mm (in)	1,700 (66.93)	1,700 (66.93)	1,700 (66.93)	1,700 (66.93)	1,700 (66.93)	1,700 (66.93)
Maximum Cargo Height (pg. 176)	Without Cargo Mat mm (in)	1,892 (74.49)	1,892 (74.49)	1,892 (74.49)	1,892 (74.49)	1,892 (74.49)	1,892 (74.49)
	With Cargo Mat mm (in)	1,883 (74.13)	1,883 (74.13)	1,883 (74.13)	1,883 (74.13)	1,883 (74.13)	1,883 (74.13)
Maximum Cargo Length at Floor - Behind Center Console at Vehicle Center	mm (in)	2,954 (116.3)	2,954 (116.3)	2,954 (116.3)	2,954 (116.3)	2,954 (116.3)	2,954 (116.3)
Maximum Cargo Length at Floor - Without Center Console at Vehicle Center	mm (in)	3,679 (144.84)	3,679 (144.84)	3,679 (144.84)	3,679 (144.84)	3,679 (144.84)	3,679 (144.84)
Maximum Cargo Length at Floor - Behind Seat (pg. 176)	mm (in)	3,016 (118.74)	3,016 (118.74)	3,016 (118.74)	3,016 (118.74)	3,016 (118.74)	3,016 (118.74)

INTERIOR MEASUREMENTS — HIGH ROOF

[RESOURCE CHARTS]

INTERIOR MEASUREMENTS – HIGH ROOF							
Item	Model Grade Engine	NV2500 S V6 Engine	NV2500 SV/SL* V6 Engine	NV2500 S V8 Engine	NV2500 SV/SL* V8 Engine	NV3500 S V8 Engine	NV3500 SV/SL* V8 Engine
Maximum Cargo Length Behind Front Seat Back (pg. 176)	mm (in)	3,186 (125.43)	3,186 (125.43)	3,186 (125.43)	3,186 (125.43)	3,186 (125.43)	3,186 (125.43)
Cargo Volume	m ³ (ft ³)	9.1 (323.1)	9.1 (323.1)	9.1 (323.1)	9.1 (323.1)	9.1 (323.1)	9.1 (323.1)

*: SL grade new for 2015 model year.

EXTERIOR MEASUREMENTS — HIGH ROOF

NOTE:

All specifications are the same for USA, Canada and Mexico except where indicated.

EXTERIOR MEASUREMENTS — HIGH ROOF							
Item	Model Grade Engine	NV2500 S V6 Engine	NV2500 SV/SL* V6 Engine	NV2500 S V8 Engine	NV2500 SV/SL* V8 Engine	NV3500 S V8 Engine	NV3500 SV/SL* V8 Engine
Vehicle Height (pg. 212)	mm (in)	2,667 (105)	2,667 (105)	2,667 (105)	2,667 (105)	2,692 (106)	2,692 (106)
Wheelbase (pg. 212)	mm (in)	3,710 (146.1)	3,710 (146.1)	3,710 (146.1)	3,710 (146.1)	3,710 (146.1)	3,710 (146.1)
Wheel Type (pg. 351)	—	Styled Steel	SV: Styled Steel	Styled Steel	SV: Styled Steel	Styled Steel	SV: Styled Steel
			SL*: Styled - Chrome Clad		SL*: Styled - Chrome Clad		SL*: Styled - Chrome Clad
Front Tread Width	mm (in)	1,745 (68.7)	1,745 (68.7)	1,745 (68.7)	1,745 (68.7)	1,745 (68.7)	1,745 (68.7)
Rear Tread Width	mm (in)	1,750 (68.9)	1,750 (68.9)	1,750 (68.9)	1,750 (68.9)	1,750 (68.9)	1,750 (68.9)
Turning Radius (pg. 350)	m (ft)	13.8 (45.2)	13.8 (45.2)	13.8 (45.2)	13.8 (45.2)	13.8 (45.2)	13.8 (45.2)
Cargo Area Liftover Height (pg. 212)	mm (in)	725 (28.5)	725 (28.5)	725 (28.5)	725 (28.5)	725 (28.5)	725 (28.5)
Slide Door Opening Width - Maximum Clearance, Without Door (pg. 205)	Without Door Seal and Interior Trim mm (in)	1,114 (43.86)	1,114 (43.86)	1,114 (43.86)	1,114 (43.86)	1,114 (43.86)	1,114 (43.86)
	With Door Seal and Interior Trim mm (in)	1,104 (43.46)	1,104 (43.46)	1,104 (43.46)	1,104 (43.46)	1,104 (43.46)	1,104 (43.46)

EXTERIOR MEASUREMENTS — HIGH ROOF							
Item	Model Grade Engine	NV2500 S V6 Engine	NV2500 SV/SL* V6 Engine	NV2500 S V8 Engine	NV2500 SV/SL* V8 Engine	NV3500 S V8 Engine	NV3500 SV/SL* V8 Engine
Slide Door Opening Width - Maximum Clearance, With Door (pg. 207)	Without Door Seal mm (in)	1,100 (43.31)	1,100 (43.31)	1,100 (43.31)	1,100 (43.31)	1,100 (43.31)	1,100 (43.31)
	With Door Seal mm (in)	1,096 (43.15)	1,096 (43.15)	1,096 (43.15)	1,096 (43.15)	1,096 (43.15)	1,096 (43.15)
Slide Door Opening Height - Maximum Clearance (pg. 205)	Without Door Seal and Interior Trim mm (in)	1,695 (66.73)	1,695 (66.73)	1,695 (66.73)	1,695 (66.73)	1,695 (66.73)	1,695 (66.73)
	With Door Seal and Interior Trim mm (in)	1,680 (66.14)	1,680 (66.14)	1,680 (66.14)	1,680 (66.14)	1,680 (66.14)	1,680 (66.14)
Vehicle Length (pg. 212)	mm (in)	6,112 (240.6)	6,112 (240.6)	6,112 (240.6)	6,112 (240.6)	6,112 (240.6)	6,112 (240.6)
Front Overhang (pg. 212)	mm (in)	1,063 (41.9)	1,063 (41.9)	1,063 (41.9)	1,063 (41.9)	1,063 (41.9)	1,063 (41.9)
Rear Overhang (pg. 212)	mm (in)	1,339 (52.7)	1,339 (52.7)	1,339 (52.7)	1,339 (52.7)	1,339 (52.7)	1,339 (52.7)
Rear Door Opening Height - Maximum Clearance (pg. 209)	Without Door Seal and Cargo Mat mm (in)	1,845 (72.64)	1,845 (72.64)	1,845 (72.64)	1,845 (72.64)	1,845 (72.64)	1,845 (72.64)
	With Door Seal and Cargo Mat mm (in)	1,822 (71.73)	1,822 (71.73)	1,822 (71.73)	1,822 (71.73)	1,822 (71.73)	1,822 (71.73)

EXTERIOR MEASUREMENTS — HIGH ROOF							
Item	Model Grade Engine	NV2500 S V6 Engine	NV2500 SV/SL* V6 Engine	NV2500 S V8 Engine	NV2500 SV/SL* V8 Engine	NV3500 S V8 Engine	NV3500 SV/SL* V8 Engine
Rear Door Opening Width - Maximum Clearance (pg. 209)	Without Door Seal mm (in)	1,567 (61.69)	1,567 (61.69)	1,567 (61.69)	1,567 (61.69)	1,567 (61.69)	1,567 (61.69)
	With Door Seal mm (in)	1,561 (61.46)	1,561 (61.46)	1,561 (61.46)	1,561 (61.46)	1,561 (61.46)	1,561 (61.46)
Vehicle Width - Without Mirrors (pg. 212)	mm (in)	2,030 (79.9)	2,030 (79.9)	2,030 (79.9)	2,030 (79.9)	2,030 (79.9)	2,030 (79.9)
Vehicle Width - Without Tow Mirrors (pg. 210)	mm (in)	2,466 (97.9)	2,466 (97.9)	2,466 (97.9)	2,466 (97.9)	2,466 (97.9)	2,466 (97.9)
Vehicle Width - With Tow Mirrors Non-Extended (pg. 210)	mm (in)	—	—	2,610 (102.08)	2,610 (102.08)	2,610 (102.08)	2,610 (102.08)
Vehicle Width - With Tow Mirrors Extended (pg. 210)	mm (in)	—	—	2,758 (108.6)	2,758 (108.6)	2,758 (108.6)	2,758 (108.6)
Ground Clearance	mm (in)	205 (8.1)	205 (8.1)	205 (8.1)	205 (8.1)	205 (8.1)	205 (8.1)
Step-in Height - Front	mm (in)	457 (18)	457 (18)	457 (18)	457 (18)	475 (18.7)	475 (18.7)
Step-in Height - Slide Door	mm (in)	493 (19.4)	493 (19.4)	493 (19.4)	493 (19.4)	513 (20.2)	513 (20.2)
Step-in Height - Rear	mm (in)	503 (19.8)	503 (19.8)	503 (19.8)	503 (19.8)	531 (20.9)	531 (20.9)

*: SL grade new for 2015 model year

BODY DIMENSIONS

PASSENGER COMPARTMENT

Front Center Console Removal and Installation



CAUTION:

Before removing the center console, ignition switch OFF.

Removal

1. Remove both front seat armrests (if equipped). Refer to [Front Seat Armrest Removal and Installation \(pg. 168\)](#) in this section.
2. Disconnect the center console harness connector (1) located under floor trim (2) near the front edge of the driver seat.

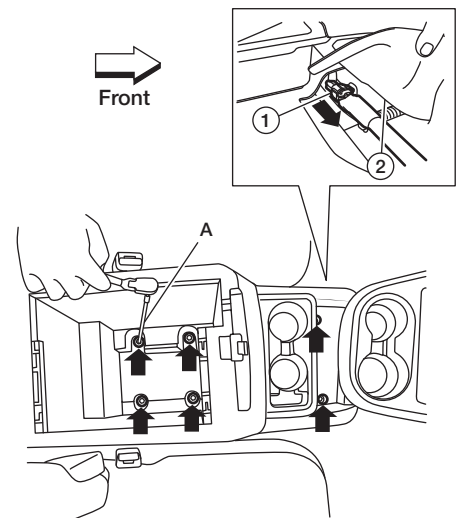

AAZIA0279GB

3. Open the center console lid and remove storage tray (for access). Using a suitable tool (A), remove the four bolts located inside the console.
4. Remove the two bolts located in the front storage tray.
5. Remove center console as an assembly from the floor.



CAUTION:

Always use an assistant to steady the front center console assembly during removal from vehicle interior.

Installation

Installation is in the reverse order of removal.

Front Seat Armrest Removal and Installation

NOTE:

Passenger seat shown, driver seat similar.

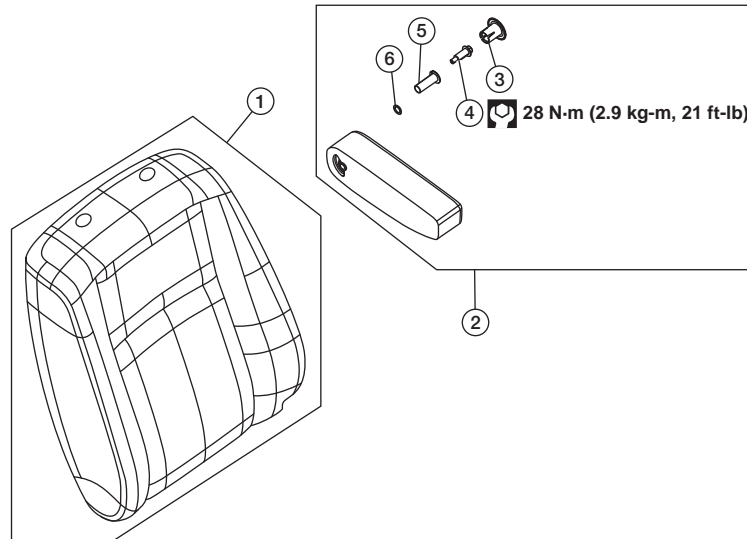

AAZIA0192ZZ

1. Seatback assembly

2. Armrest assembly

3. Armrest bolt cover

4. Armrest bolt

5. Armrest insert

6. Armrest washer

**WARNING:**

Do not leave any objects (screwdrivers, tools, etc.) on the seat during armrest removal and installation. It can lead to personal injury if the side air bag module should accidentally deploy.

**WARNING:**

To avoid possible unexpected deployment or deployment failure, do not damage the side air bag module when installing the armrest assembly. Doing so may result in severe personal injury.

**CAUTION:**

- Handle the armrest assembly carefully to avoid damage when removing or installing it.
- Use a suitable cover to protect the seat from damage when removing and installing the armrest assembly.

Removal

1. Using an appropriate tool, release and remove the armrest bolt cover (3) from the armrest assembly (2).
2. Remove the armrest bolt (4), insert (5), washer (6) and armrest assembly from the seatback assembly. Note part positions for correct assembly.

Installation

Installation is in the reverse order of removal.

Dimensions

Front Center Console Mounting Holes

NOTE:

The center console is not standard equipment on certain cargo van models. A Genuine NISSAN console assembly can be obtained from a NISSAN Dealer (part number 96910-1PA0A).

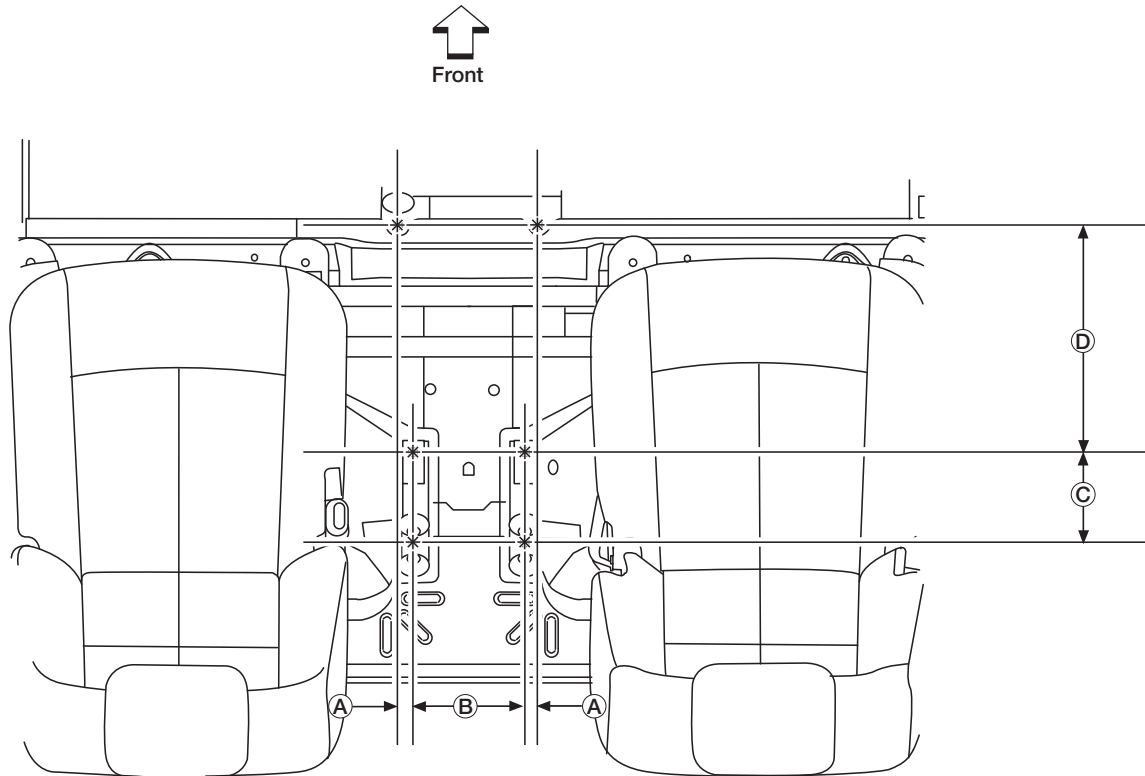

AAZIA0057ZZ

A. 26 mm (1.02 in)

B. 170 mm (6.69 in)

C. 145 mm (5.71 in)

D. 357 mm (14.06 in)

Seat Mounting Holes

Front Seat Mounting Hole Dimensions

**WARNING:**

To avoid rendering the SRS inoperative, which could increase the risk of personal injury or death in the event of a collision which would result in air bag inflation, the front passenger seat cannot be permanently removed.

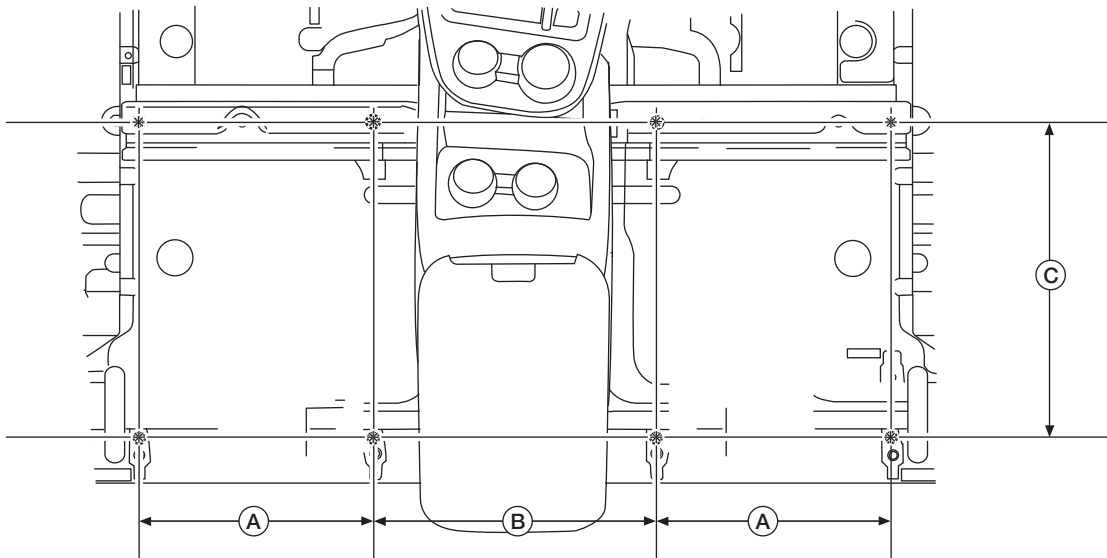

AAZIA0056ZZ

A. 430 mm (16.9 in)

B. 514 mm (20.2 in)

C. 573 mm (22.6 in)

NOTE:

For removal and installation of the seats refer to the SE section in the service manual.

Seat Position Diagrams

SgRP Front Seat Dimension

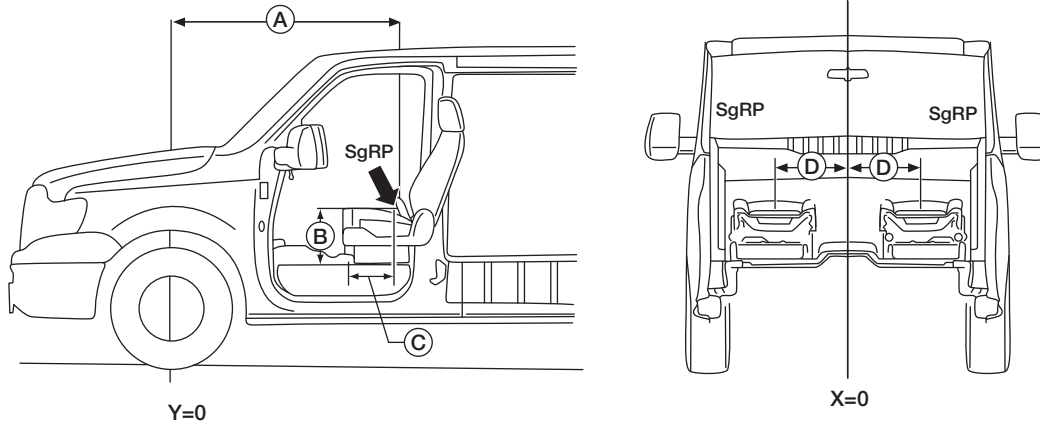

AAZIA0228GB

NOTE:**Seat is in full down and back position.**

A. 1,517 mm (59.7 in)

B. 351.3 mm (13.83 in)

C. 367.9 mm (14.48 in)

D. 455 mm (17.9 in)

PASSENGER COMPARTMENT

[BODY DIMENSIONS]

LH Manual Track

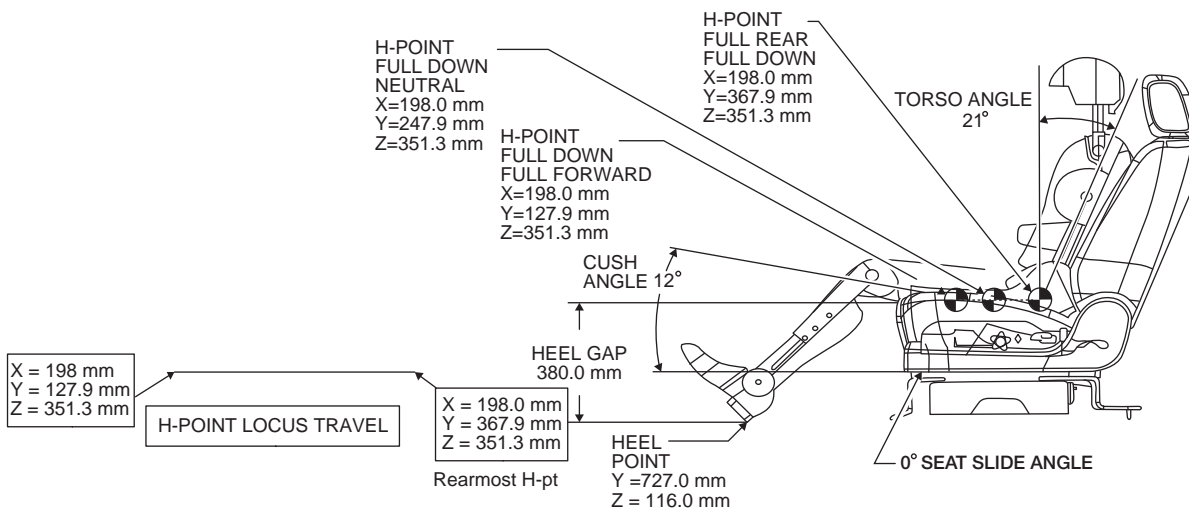

AAZIA0277GB

NOTE:

The X, Y, Z values are measured from the front seat front bolt holes.

LH Power Track

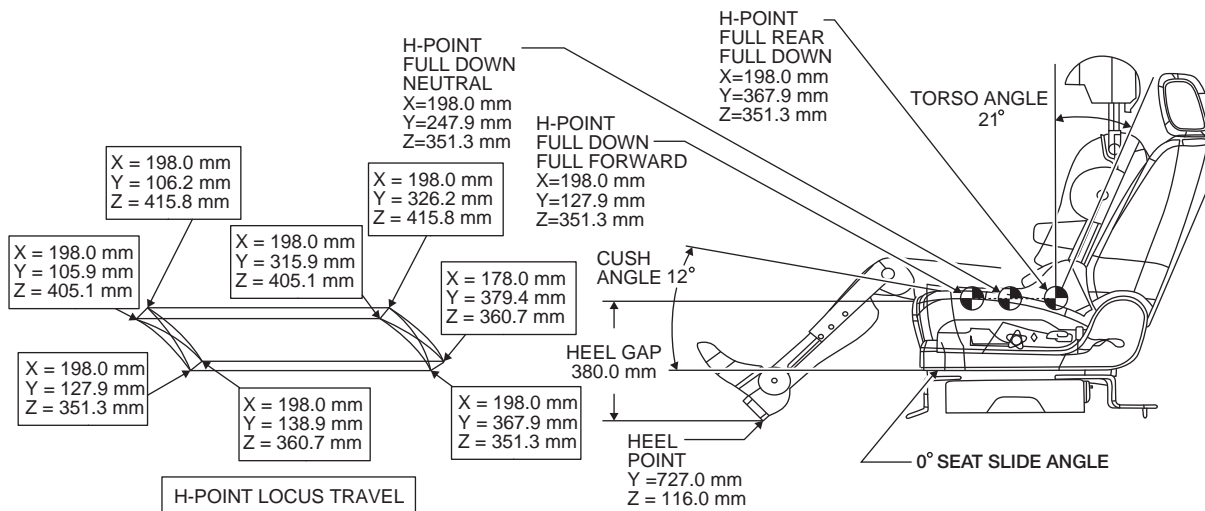

AAZIA0276GB

NOTE:

The X, Y, Z values are measured from the front seat front bolt holes.

RH Manual Track

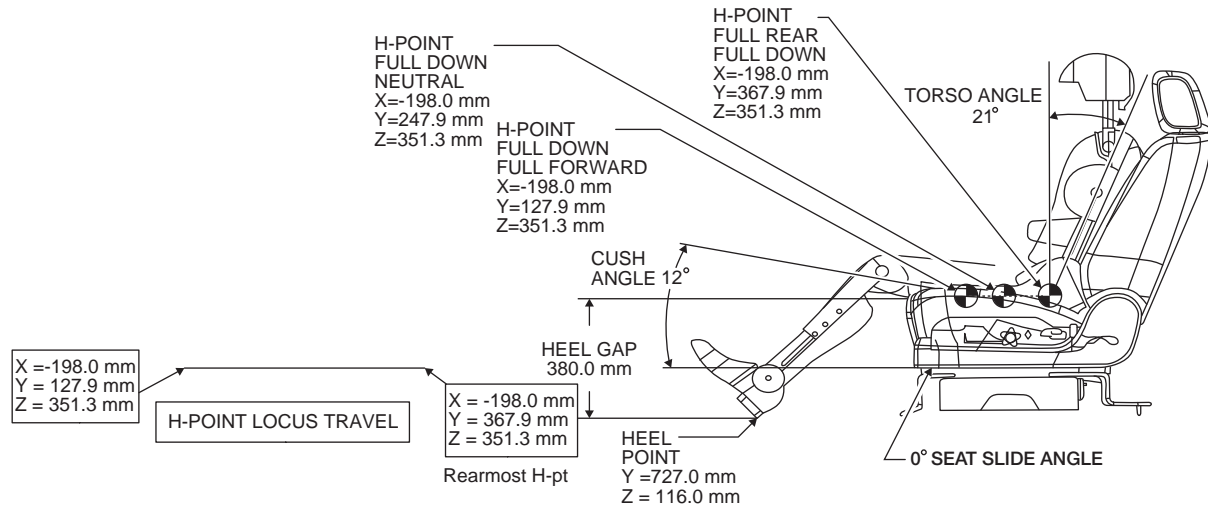

AAZIA0275GB

NOTE:

The X, Y, Z values are measured from the front seat front bolt holes.

CARGO AREA

Interior Dimensions

Overall — Standard Roof

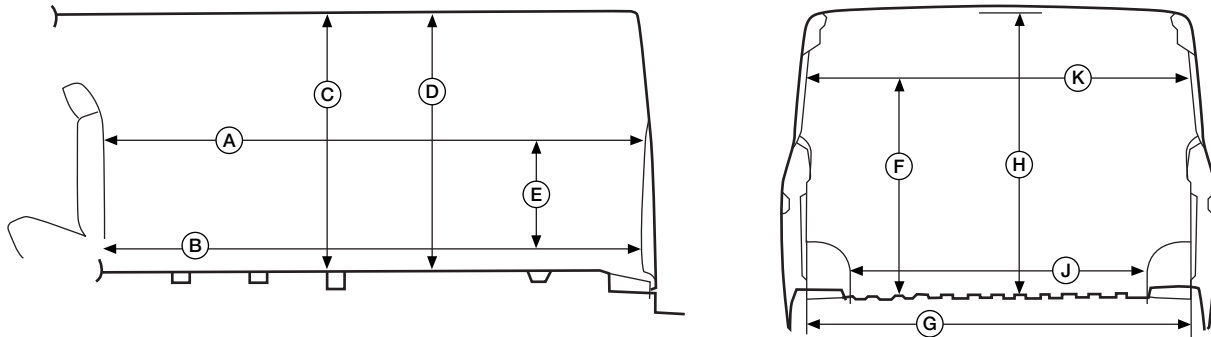

AAZIA0374ZZ

Without Cargo Mat

A. Maximum cargo length behind front seat back (full upright position):

- Rear-most seat position:
2,928 mm (115.28 in)
- Front-most seat position:
3,186 mm (125.43 in)

D. Height at rear wheel center:
1,359 mm (53.50 in)

G. Maximum cargo width at floor rear:
1,783 mm (70.2 in)

K. Width between C-pillars:
1,700 mm (66.93 in)

B. Maximum cargo length at floor behind seat:
3,016 mm (118.74 in)

E. Reference height from floor:
585 mm (23.03 in)

H. Maximum height at rear cargo entrance with striker:
1,262 mm (49.68 in)

L. Maximum cargo width at floor rear:
1,783 mm (70.2 in)

C. Maximum cargo height at C-pillar:
1,359 mm (53.5 in)

F. Reference height from floor:
1,020 mm (40.16 in)

J. Width at floor between wheel wells:
1,378 mm (54.25 in)

M. Width between C-pillars:
1,700 mm (66.93 in)

With Cargo Mat

A. Maximum cargo length behind front seat back (full upright position):

- Rear-most seat position:
2,928 mm (115.28 in)
- Front-most seat position:
3,186 mm (125.43 in)

D. Height at rear wheel center:
1,350 mm (53.15 in)

G. Maximum cargo width at floor rear:
1,783 mm (70.2 in)

K. Width between C-pillars:
1,700 mm (66.93 in)

B. Maximum cargo length at floor behind seat:
3,016 mm (118.74 in)

E. Reference height from floor:
585 mm (23.03 in)

H. Maximum height at rear cargo entrance with striker:
1,244 mm (48.98 in)

L. Maximum cargo width at floor rear:
1,783 mm (70.2 in)

C. Maximum cargo height at C-pillar:
1,350 mm (53.15 in)

F. Reference height from floor:
1,020 mm (40.16 in)

J. Width at floor between wheel wells:
1,378 mm (54.25 in)

M. Width between C-pillars:
1,700 mm (66.93 in)

Overall – High Roof

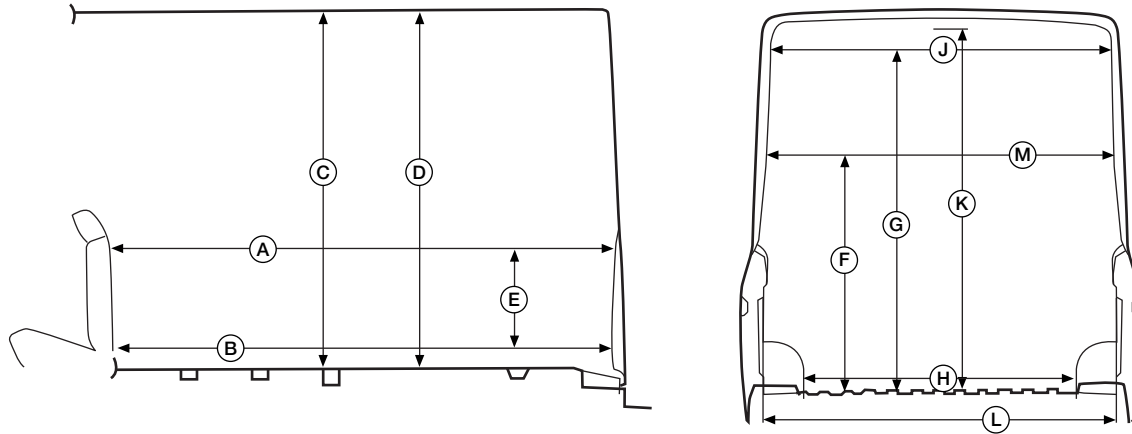

AAZIA0375ZZ

Without Cargo Mat

A. Maximum cargo length behind front seat back (full upright position):

- Rear-most seat position:
2,928 mm (115.28 in)
- Front-most seat position:
3,186 mm (125.43 in)

D. Height at rear wheel center:
1,892 mm (74.49 in)

G. Reference height from floor:
1,725 mm (67.91 in)

K. Maximum height at rear cargo entrance with striker:
1,798 mm (70.79 in)

B. Maximum cargo length at floor behind seat:
3,016 mm (118.74 in)

E. Reference height from floor:
585 mm (23.03 in)

H. Width at floor between wheel wells:
1,378 mm (54.25 in)

L. Maximum cargo width at floor rear:
1,783 mm (70.2 in)

C. Maximum cargo height at C-pillars:
1,892 mm (74.49 in)

F. Reference height from floor:
1,020 mm (40.16 in)

J. Width between C-pillars:
1,532 mm (60.31 in)

M. Width between C-pillars:
1,700 mm (66.93 in)

With Cargo Mat

<p>A. Maximum cargo length behind front seat back (full upright position):</p> <ul style="list-style-type: none"> • Rear-most seat position: 2,928 mm (115.28 in) • Front-most seat position: 3,186 mm (125.43 in) 	<p>B. Maximum cargo length at floor behind seat: 3,016 mm (118.74 in)</p>	<p>C. Maximum cargo height at C-pillars: 1,883 mm (74.13 in)</p>
<p>D. Height at rear wheel center: 1,883 mm (74.13 in)</p>	<p>E. Reference height from floor: 585 mm (23.03 in)</p>	<p>F. Reference height from floor: 1,020 mm (40.16 in)</p>
<p>G. Reference height from floor: 1,725 mm (67.91 in)</p>	<p>H. Width at floor between wheel wells: 1,378 mm (54.25 in)</p>	<p>J. Width between C-pillars: 1,532 mm (60.31 in)</p>
<p>K. Maximum height at rear cargo entrance with striker: 1,762 mm (69.37 in)</p>	<p>L. Maximum cargo width at floor rear: 1,783 mm (70.2 in)</p>	<p>M. Width between C-pillars: 1,700 mm (66.93 in)</p>

CARGO AREA

[BODY DIMENSIONS]

Overall – Top View

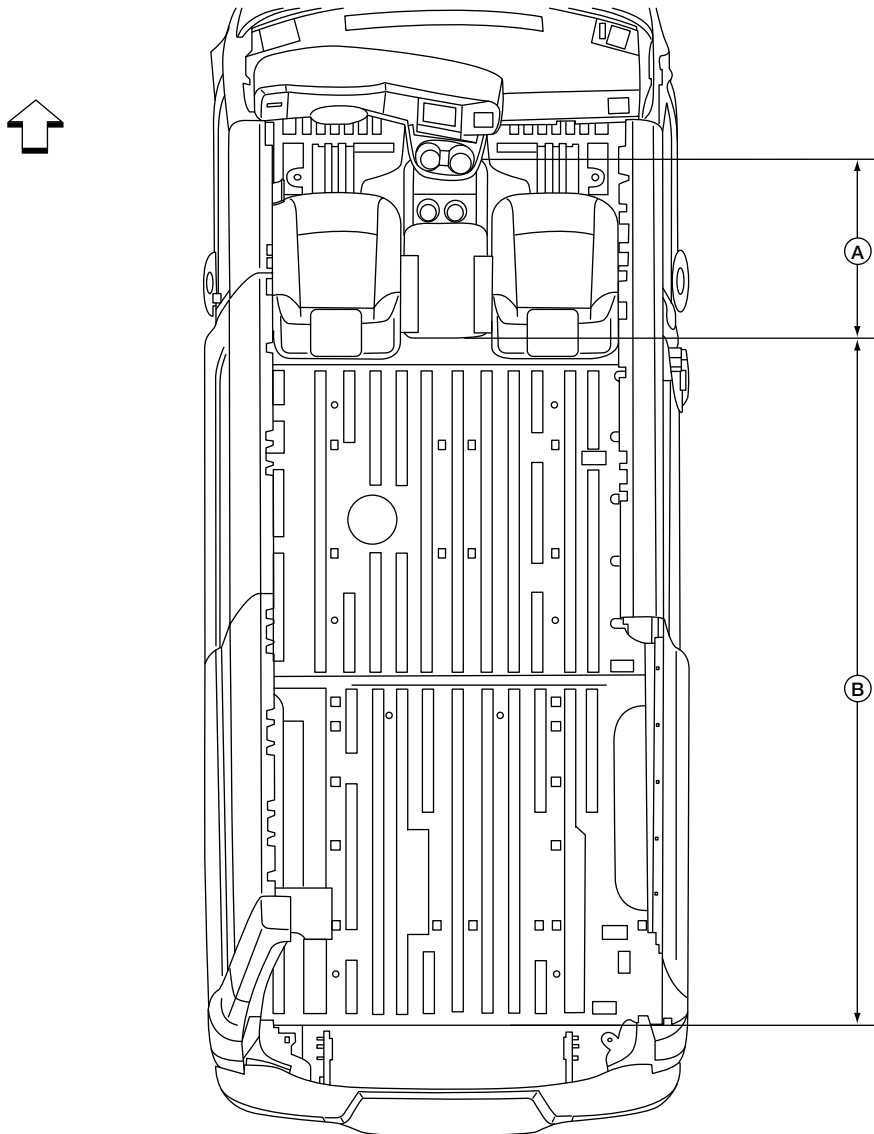

AAZIA0203ZZ

↶: Front of vehicle.

A. 725 mm (28.5 in)

B. 3,095 mm (121.9 in)

Wheel Well Clearance

Cutaway Side View – RH

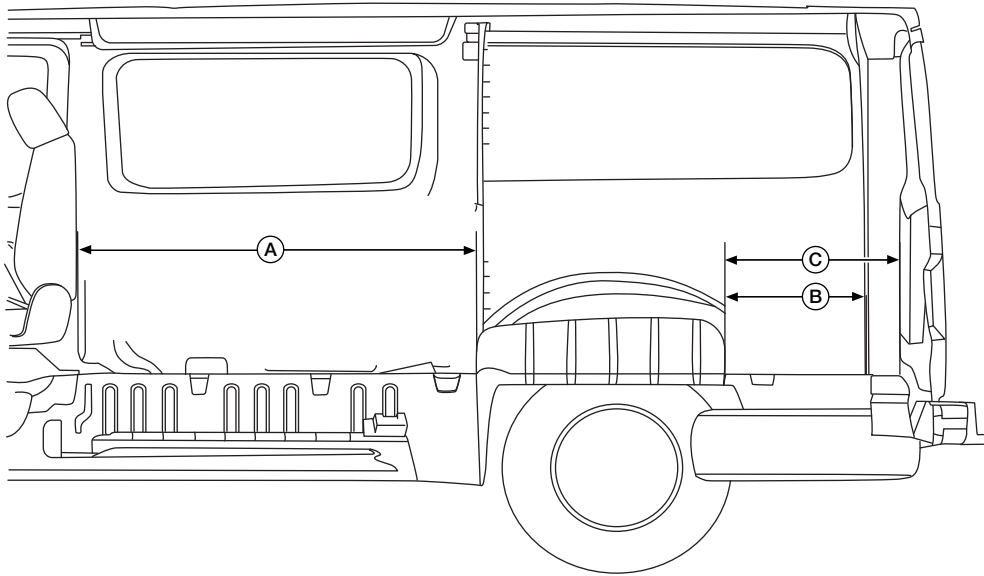

AAZIA0365ZZ

NOTE:

View from inside of vehicle.

1,544 mm (60.79 in)

B. 472 mm (18.58 in)

C. 590 mm (23.23 in)

Cutaway Side View – LH

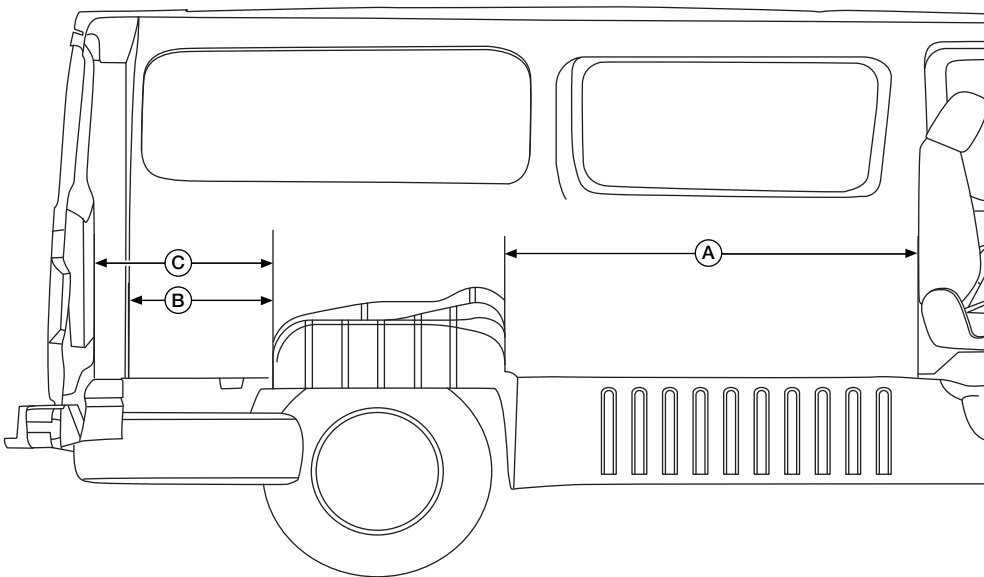

AAZIA0366ZZ

NOTE:

View from inside of vehicle.

A. 1,460 mm (57.48 in)

B. 462 mm (18.19 in)

C. 592 mm (23.31 in)

Cutaway Wheel Well and Rear Views

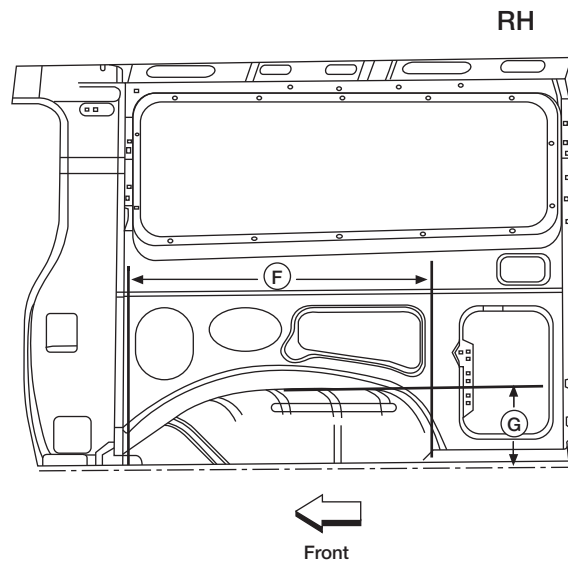
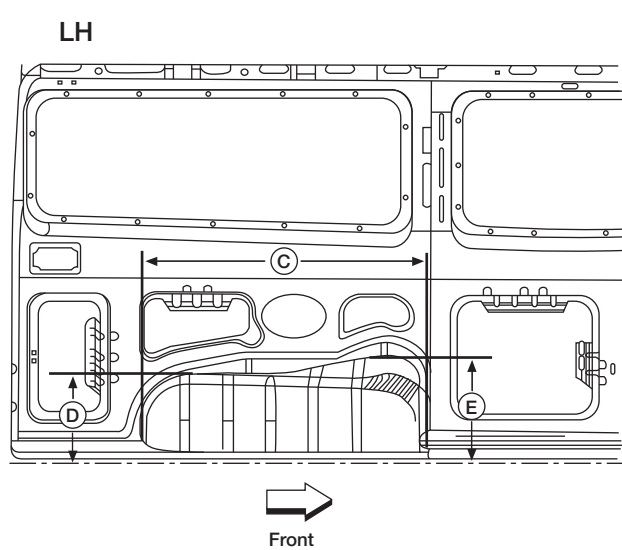
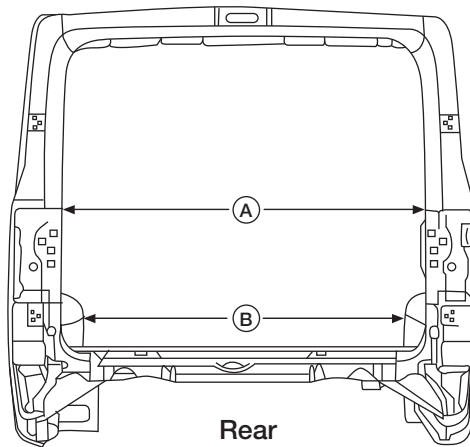

AAZIA0285GB

NOTE:

Standard roof shown, high roof similar.

Without Cargo Mat

A. 1,569 mm (61.77 in)

B. 1,378 mm (54.3 in)

C. 852 mm (33.54 in)

D. 217 mm (8.54 in)

E. 282 mm (11.10 in)

F. 873 mm (34.37 in)

G. 213 mm (8.39 in)

With Cargo Mat

A. 1,569 mm (61.77 in)

B. 1,378 mm (54.25 in)

C. 852 mm (33.54 in)

D. 226 mm (8.90 in)

E. 291 mm (11.46 in)

F. 873 mm (34.37 in)

G. 222 mm (8.74 in)

Cutaway Overhead View

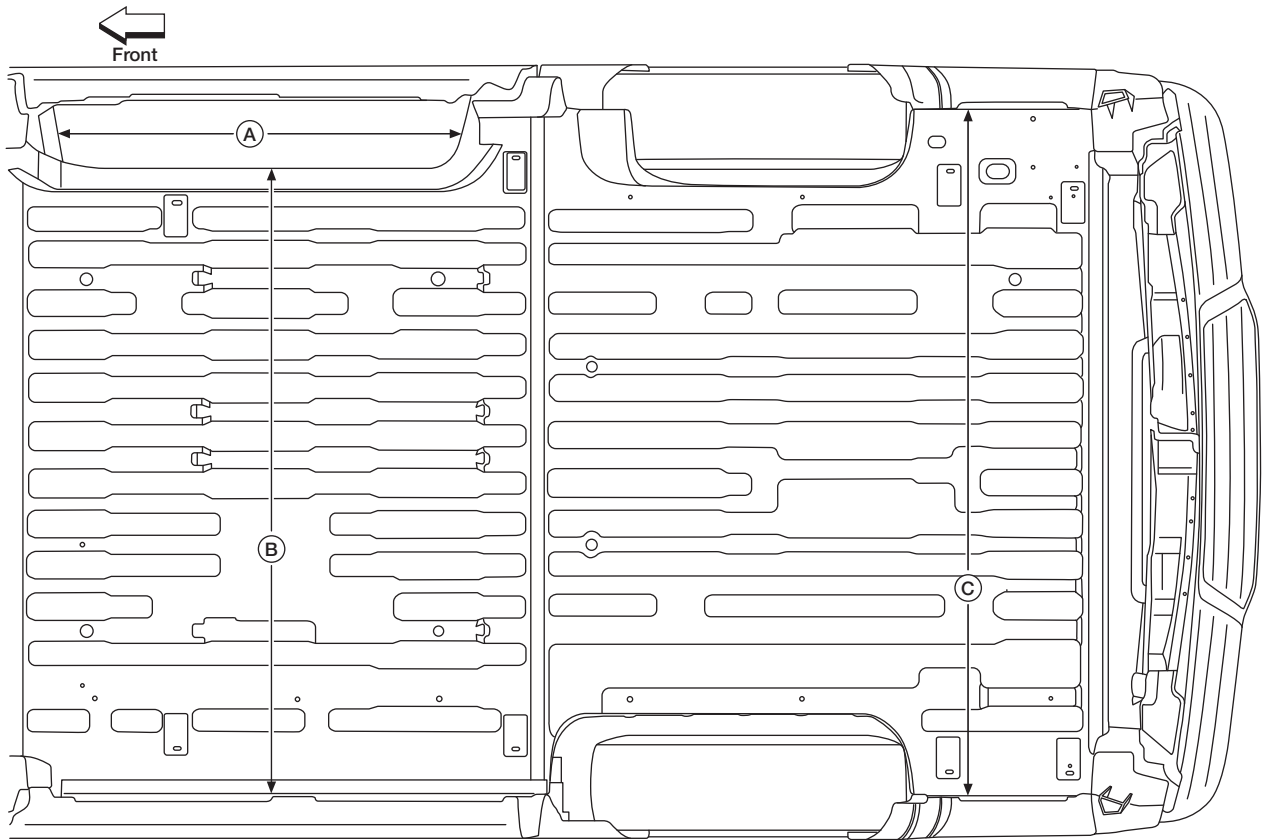

AAZIA0073ZZ

A. 1,051 mm (41.4 in)

B. 1,626 mm (64.0 in)

C. 1,782 mm (70.3 in)

D-Ring Tie-Downs

Cutaway Overhead View

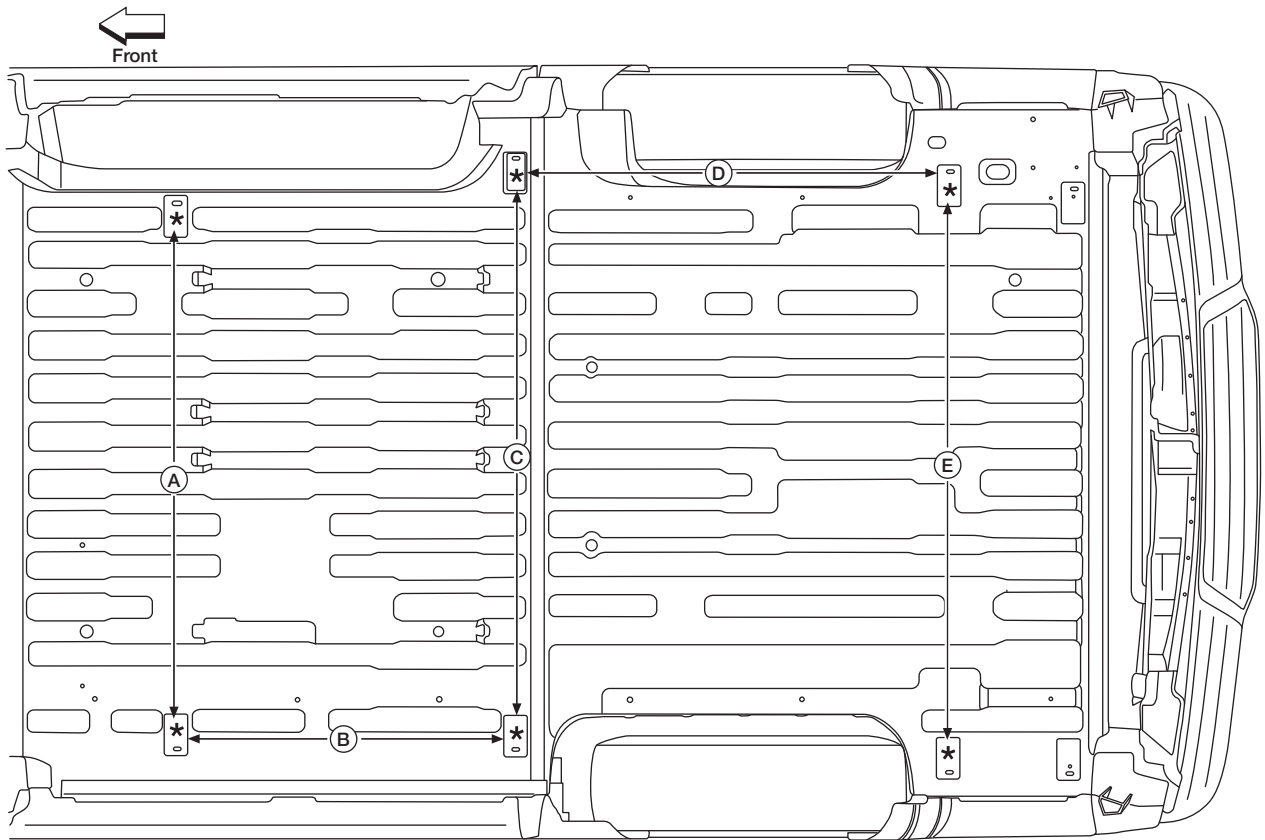

AAZIA0114ZZ



WARNING:

Do not exceed the maximum D-ring tie down loading of 5,000 N (1,124lbs) per D-ring.

* D-ring tie down bolt center.

A. 1,394 mm (54.9 in)

B. 885 mm (34.8 in)

C. 1,510 mm (59.4 in)

D. 1,140 mm (44.9 in)

E. 1,540 mm (60.6 in)

SIGN AREA — STANDARD ROOF

RH Exterior Dimensions

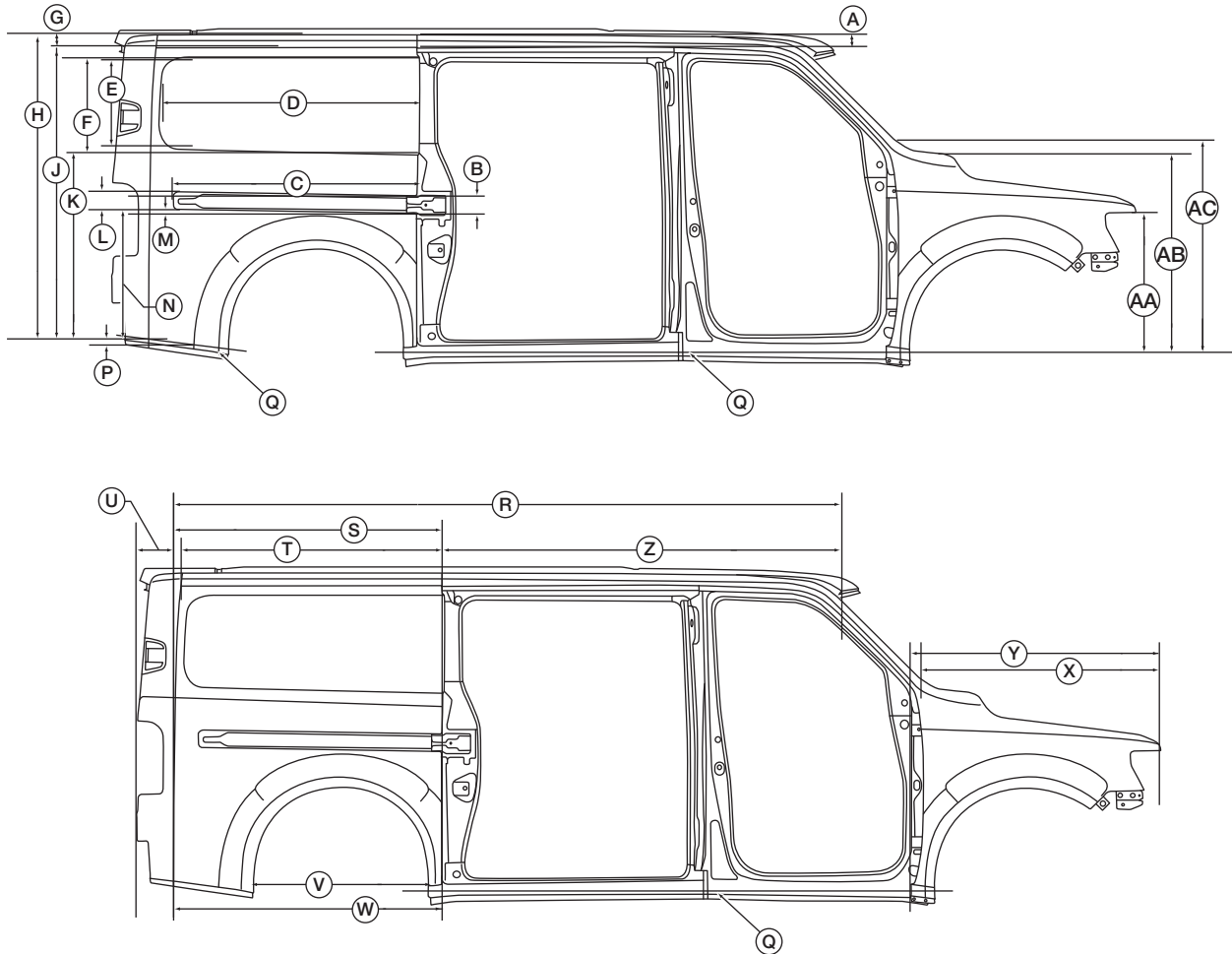

AAZIA005ZZZ

A. 63 mm (2.5 in)
 D. 1,389 mm (54.7 in)
 G. 63 mm (2.5 in)
 K. 1,025 mm (40.4 in)
 N. 710 mm (28 in)

B. 100 mm (3.9 in)
 E. 479 mm (18.9 in)
 H. 1,661 mm (65.4 in)
 L. 100 mm (3.9 in)
 P. 31 mm (1.2 in)

C. 1,305 mm (51.4 in)
 F. 514 mm (20.2 in)
 J. 1,588 mm (62.5 in)
 M. 22 mm (0.9 in)
 Q. Stone guard coating below
 line

R. 3,599 mm (141.7 in)
 U. 201 mm (7.9 in)
 X. 1,289 mm (50.7 in)
 AA. 773 mm (30.4 in)

S. 1,448 mm (57 in)
 V. 943 mm (37.1 in)
 Y. 1,345 mm (53.1 in)
 AB. 1,087 mm (42.8 in)

T. 1,410 mm (55.5 in)
 W. 1,448 mm (57 in)
 Z. 2,146 mm (84.5 in)
 AC. 1,157 mm (45.6 in)

LH Exterior Dimensions

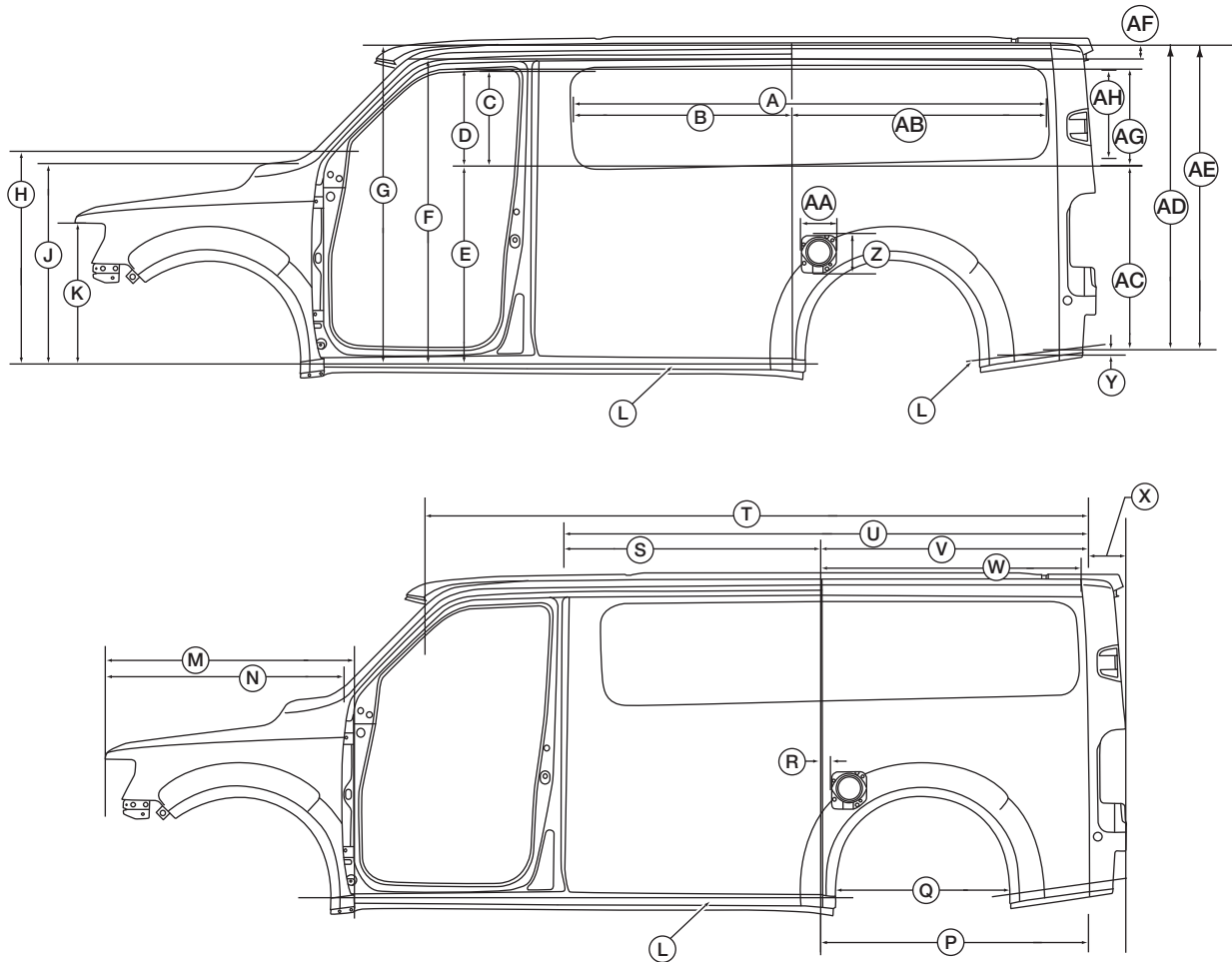

AAZIA0053ZZ

A. 2,558 mm (100.7 in)
 D. 514 mm (20.2 in)
 G. 1,725 mm (67.9 in)
 K. 773 mm (30.4 in)

N. 1,289 mm (50.7 in)
 R. 46 mm (1.8 in)
 U. 2,842 mm (111.9 in)
 X. 201 mm (7.9 in)
 AA. 197 mm (7.8 in)
 AD. 1,588 mm (62.5 in)
 AG. 514 mm (20.2 in)

B. 1,176 mm (46.3 in)
 E. 1,100 mm (43.3 in)
 H. 1,161 mm (45.7 in)
 L. Stone guard coating below
 line

P. 1,446 mm (56.9 in)
 S. 1,388 mm (54.6 in)
 V. 1,446 mm (56.9 in)
 Y. 31 mm (1.2 in)
 AB. 1,374 mm (54.1 in)
 AE. 1,661 mm (65.4 in)
 AH. 479 mm (18.9 in)

C. 528 mm (20.8 in)
 F. 1,668 mm (65.7 in)
 J. 1,087 mm (42.8 in)
 M. 1,348 mm (53.1 in)
 Q. 943 mm (37.1 in)
 T. 3,588 mm (141.3 in)
 W. 1,408 mm (55.4 in)
 Z. 209 mm (8.2 in)
 AC. 1,025 mm (40.4 in)
 AF. 63 mm (2.5 in)

Slide Door Exterior Dimensions

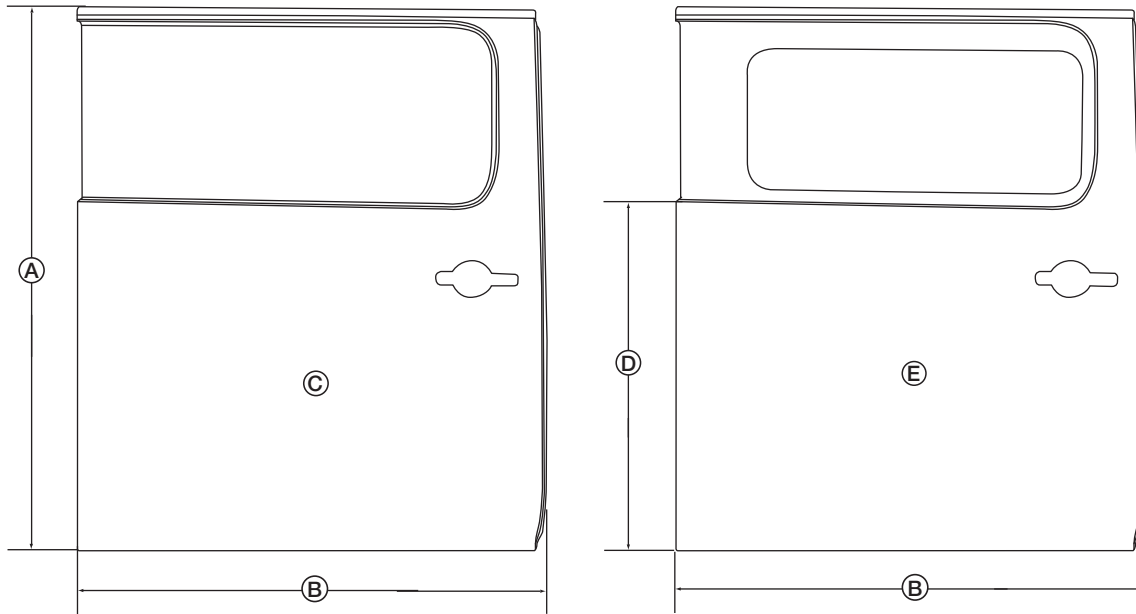

AAZIA0184GB

A. 1,617 mm (63.7 in)

B. 1,386 mm (54.6 in)

C. Slide door without glass —
surface area: 2.2 m² (21.2 ft²)

D. 1,009 mm (39.7 in)

E. Slide door with glass — sur-
face area: 1.4 m² (15.1 ft²)

Hood Surface Exterior Dimensions

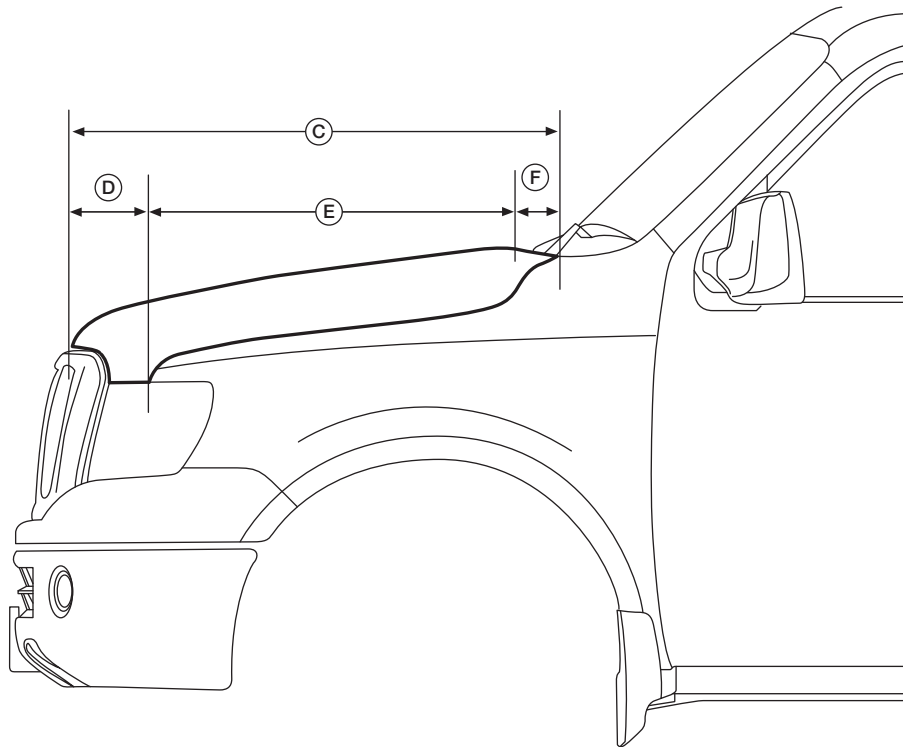
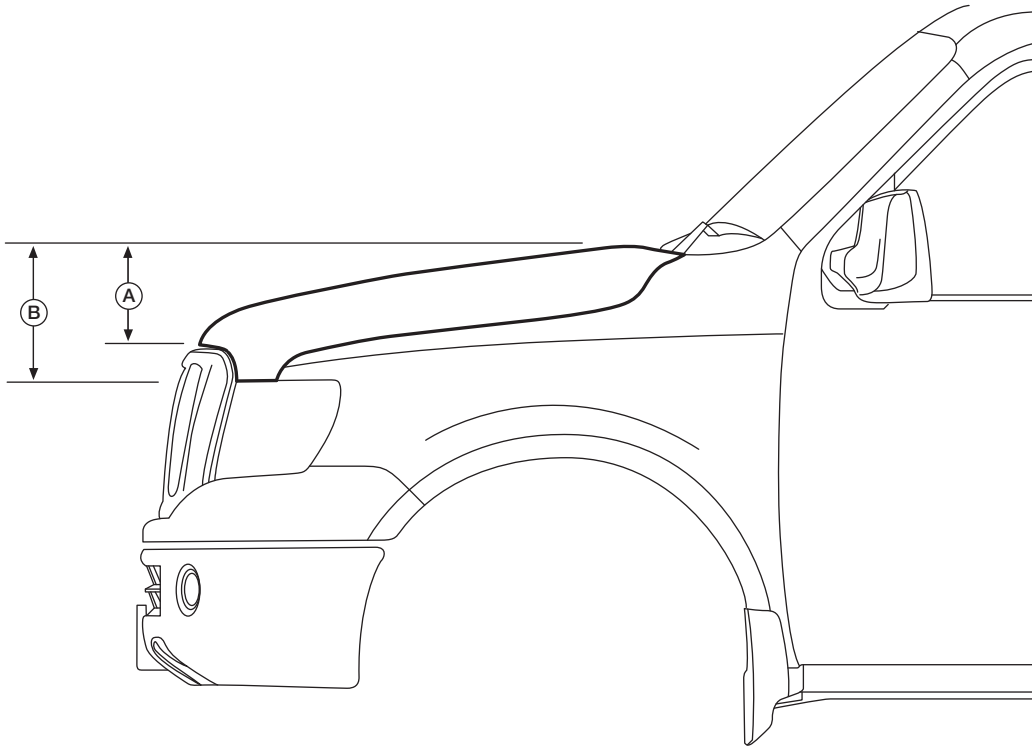

AAZIA0031ZZ

A. 256 mm (10.1 in)
D. 210 mm (8.3 in)

B. 348 mm (13.7 in)
E. 915 mm (36 in)

C. 1,249 mm (49.2 in)
F. 124 mm (5.5 in)

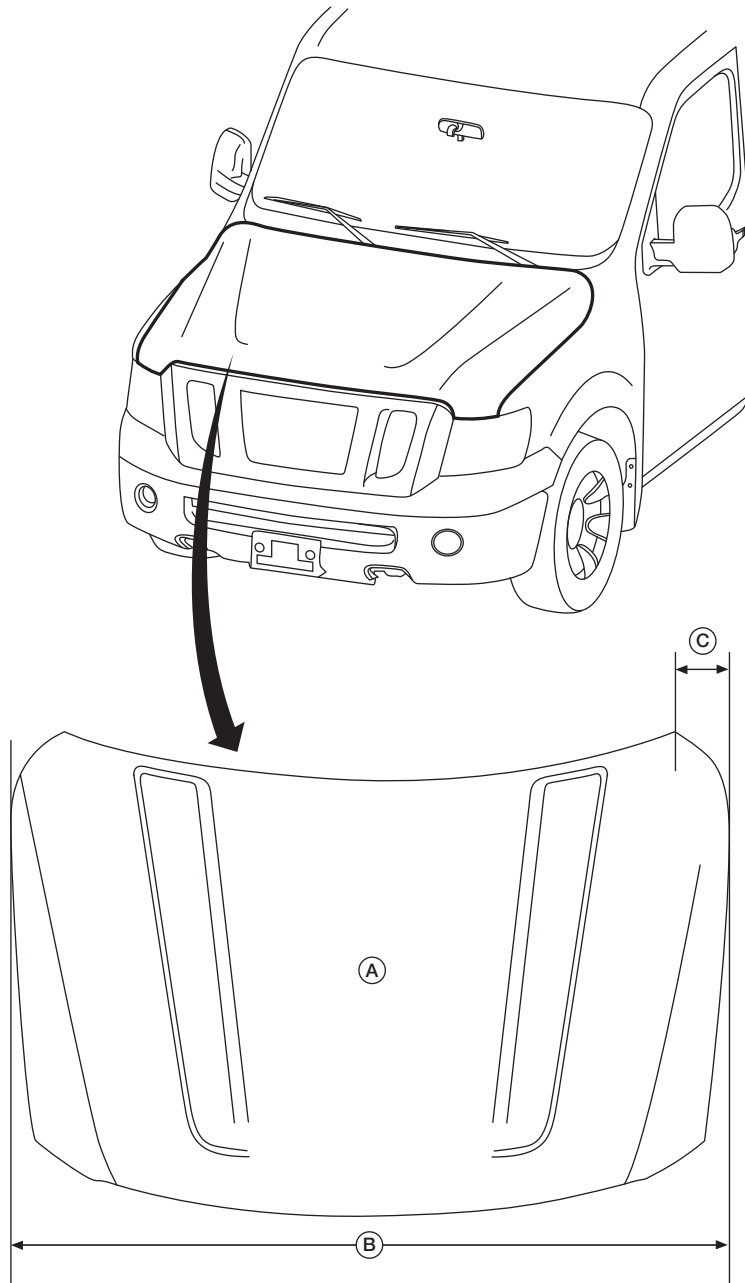

AAZIA003ZZZ

A. Flat surface area: 2.213 m²
(23.82 ft²)

B. 1,848 mm (72.7 in)

C. 140 mm (5.5 in)

Front Driver Door Sign Area

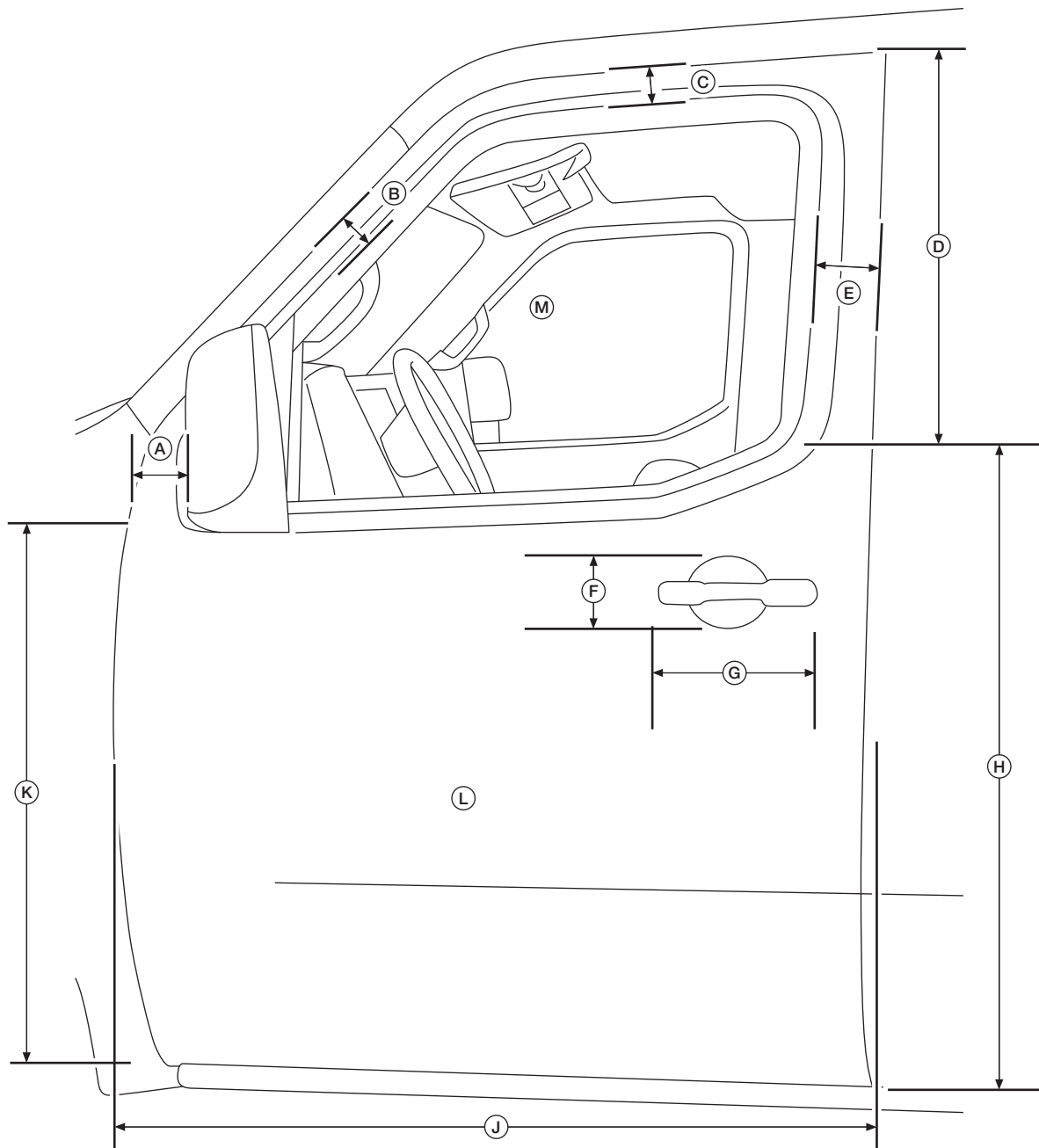

AAZIA0536ZZ

A. 79 mm (3.1 in)
 D. 563 mm (22.2 in)
 G. 226 mm (8.9 in)
 K. 763 mm (30 in)
 L. Full Door Surface area: 1.384
 m² (15 ft²)
 M. Glass and Mirror Surface
 area: .3940 m² (4.2 ft²)

B. 57 mm (2.2 in)
 E. 89 mm (3.5 in)
 H. 913 mm (36 in)

C. 57 mm (2.2 in)
 F. 120 mm (4.8 in)
 J. 1,042 mm (41 in)

Front Passenger Door Sign Area

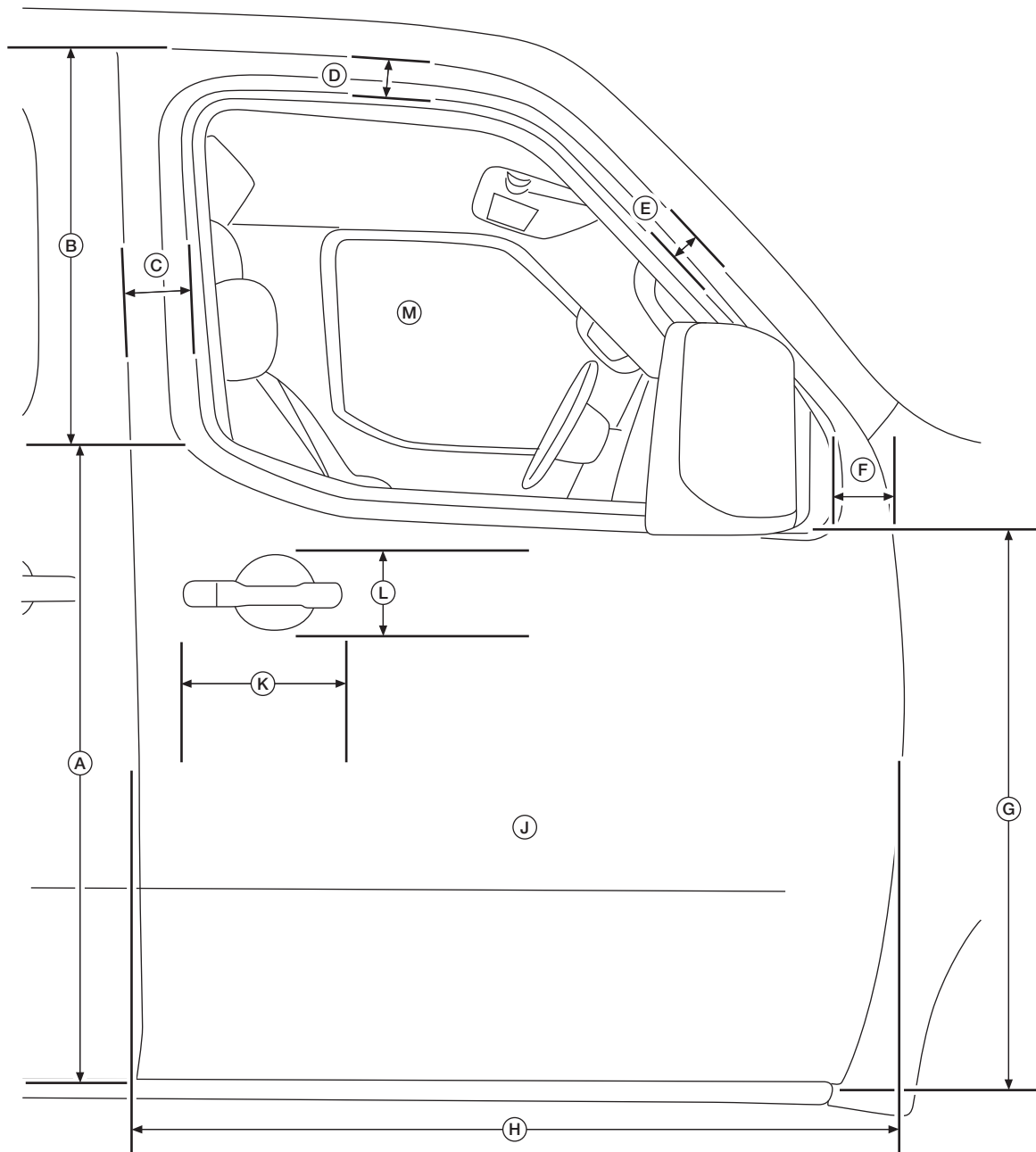

AAZIA0538ZZ

A. 913 mm (36 in)

D. 57 mm (2.2 in)

G. 763 mm (30 in)

J. Full Door Surface area: 1.384
m² (15 ft²)

L. 120 mm (4.8 in)

B. 563 mm (22.2 in)

E. 57 mm (2.2 in)

H. 1,042 mm (41 in)

K. 226 mm (8.9 in)

M. Glass and Mirror Surface
area: .3940 m² (4.2 ft²)

C. 89 mm (3.5 in)

F. 79 mm (3.1 in)

Back Door Sign Area

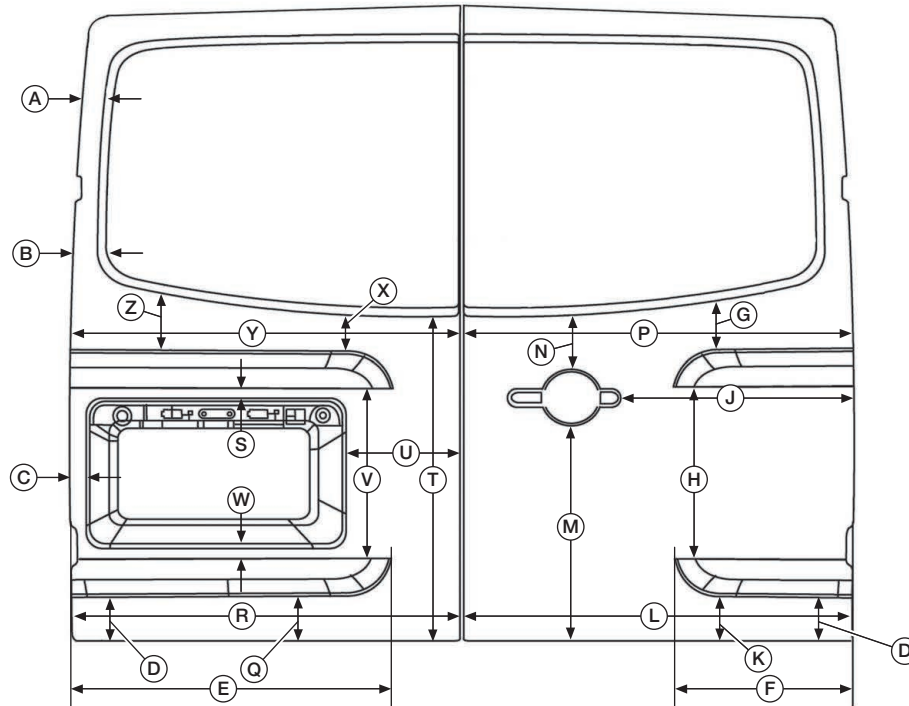

AAZIA0075ZZ

A. 57 mm (2.2 in)
 D. 98 mm (3.9 in)
 G. 123 mm (4.8 in)
 K. 100 mm (3.9 in)
 N. 127 mm (5 in)
 R. 846 mm (33.3 in)
 U. 246 mm (9.7 in)
 X. 87 mm (3.4 in)

B. 61 mm (2.4 in)
 E. 706 mm (27.8 in)
 H. 387 mm (15.2 in)
 L. 849 mm (33.4 in)
 P. 851 mm (33.5 in)
 S. 26 mm (1 in)
 V. 381 mm (15 in)
 Y. 848 mm (33.4 in)

C. 36 mm (1.4 in)
 F. 395 mm (15.6 in)
 J. 514 mm (20.2 in)
 M. 483 mm (19 in)
 Q. 103 mm (4.06 in)
 T. 734 mm (28.9 in)
 W. 28 mm (1.1 in)
 Z. 136 mm (5.4 in)

Back Door Window Opening Sign Area

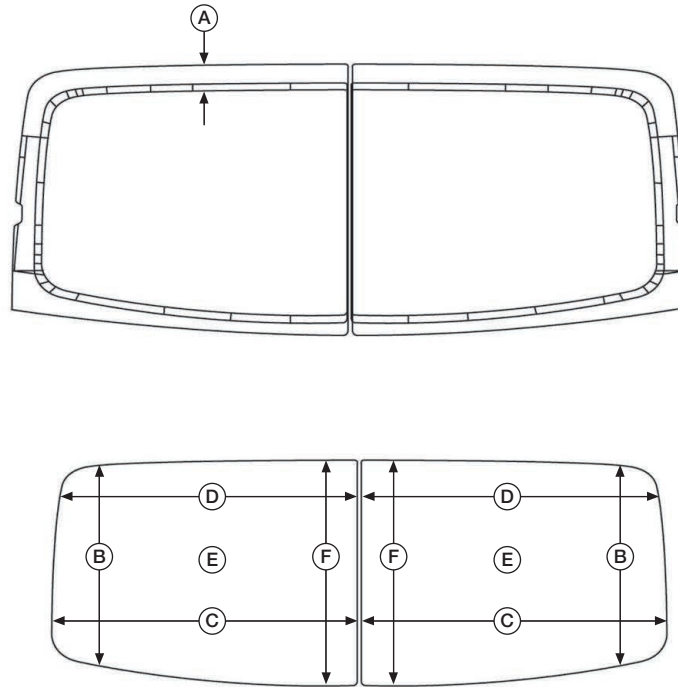

A. 52 mm (2 in)
D. 755 mm (29.7 in)

B. 523 mm (20.6 in)
E. Surface area: 0.4 m² (4.7 ft²)

C. 773 mm (30.4 in)
F. 602 mm (23.7 in)

AAZIA0014ZZ

SIGN AREA — HIGH ROOF

RH Exterior Dimensions

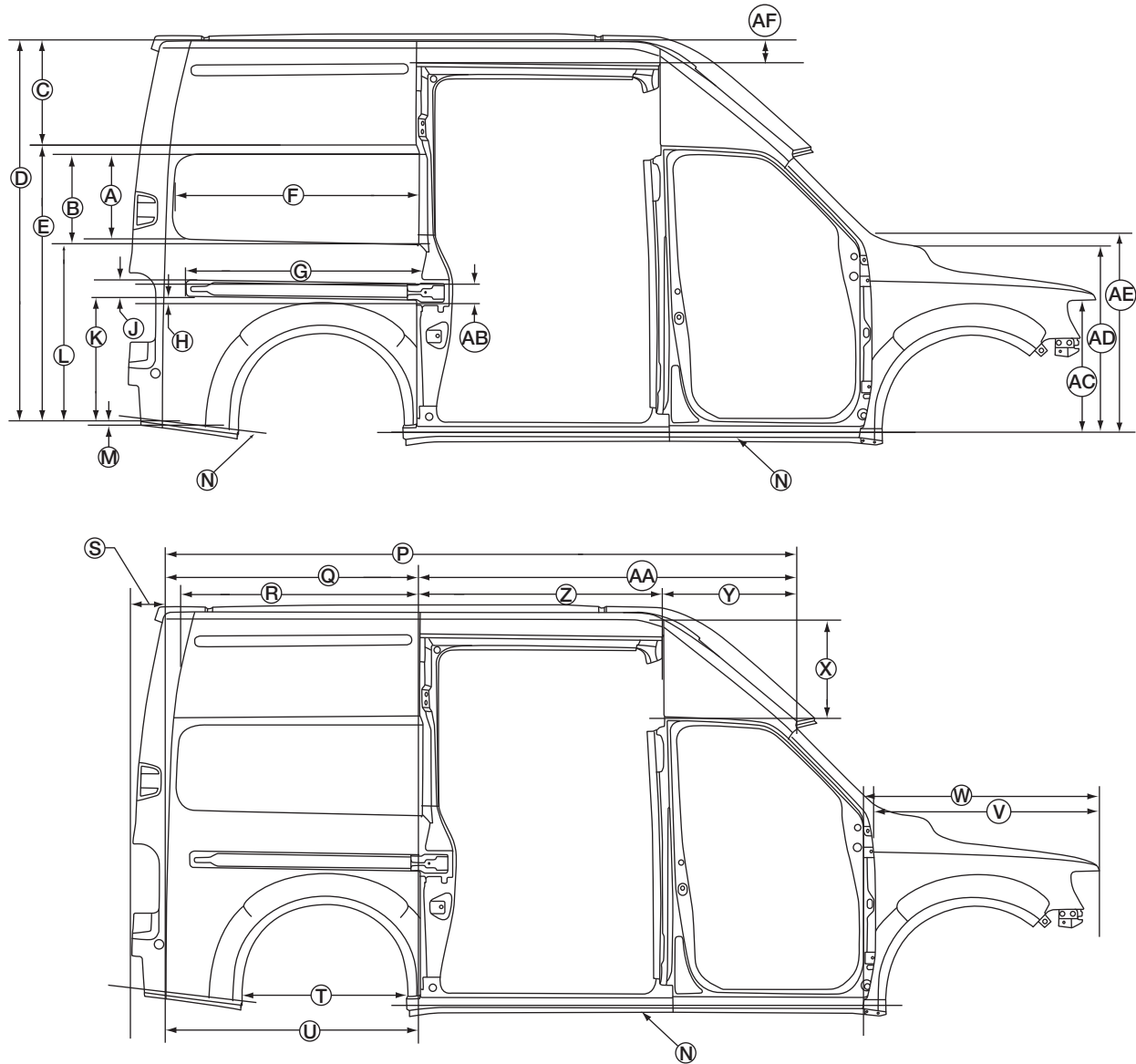

AAZIA0068ZZ

A. 479 mm (18.9 in)	B. 514 mm (20.2 in)	C. 605 mm (23.8 in)
D. 2,205 mm (86.8 in)	E. 1,588 mm (62.5 in)	F. 1,389 mm (54.7 in)
G. 1,305 mm (51.4 in)	H. 22 mm (0.9 in)	J. 100 mm (3.9 in)
K. 710 mm (28.0 in)	L. 1,025 mm (40.4 in)	M. 31 mm (1.2 in)
N. Stone guard coating below line	P. 5,388 mm (212.1 in)	Q. 1,448 mm (57.0 in)
R. 1,363 mm (53.7 in)	S. 201 mm (7.9 in)	T. 943 mm (37.1 in)
U. 1,448 mm (57.0 in)	V. 1,289 mm (50.7 in)	W. 1,345 mm (53.0 in)
X. 567 mm (22.3 in)	Y. 756 mm (29.8 in)	Z. 1,376 mm (54.2 in)
AA. 2,132 mm (83.9 in)	AB. 100 mm (3.9 in)	AC. 733 mm (28.9 in)
AD. 1,087 mm (42.8 in)	AE. 1,157 mm (45.6 in)	AF. 133 mm (5.2 in)

LH Exterior Dimensions

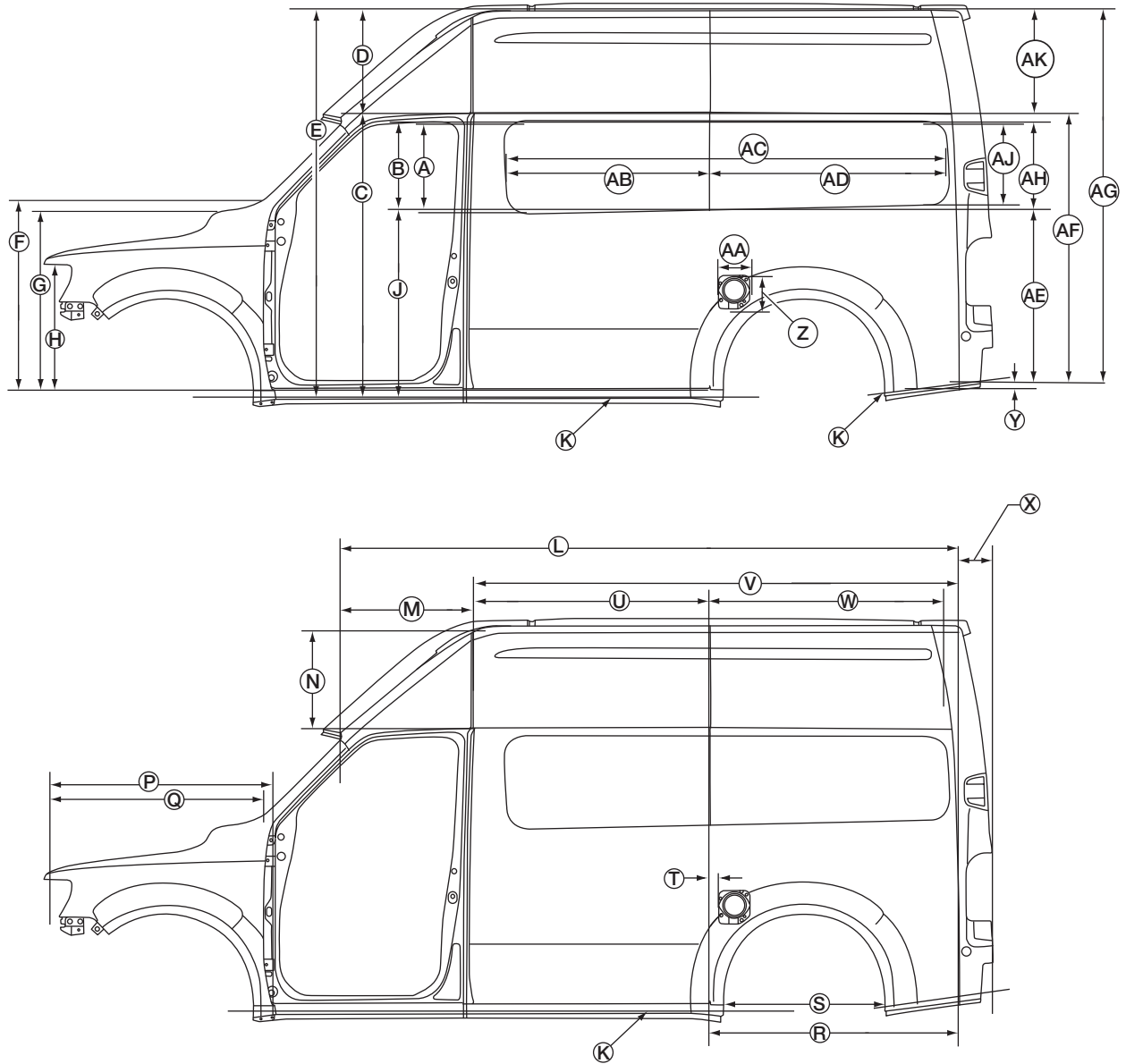

AAZIA0069ZZ

A. 528 mm (20.8 in)	B. 514 mm (20.2 in)	C. 1,668 mm (65.7 in)
D. 605 mm (23.8 in)	E. 2,282 mm (89.9 in)	F. 1,161 mm (45.7 in)
G. 1,087 mm (42.8 in)	H. 773 mm (30.4 in)	J. 1,100 mm (43.3 in)
K. Stone guard coating below line	L. 3,588 mm (141.3 in)	M. 758 mm (29.8 in)
N. 569 mm (22.4 in)	P. 1,348 mm (53.1 in)	Q. 1,289 mm (50.7 in)
R. 1,446 mm (56.9 in)	S. 569 mm (22.4 in)	T. 46 mm (1.8 in)
U. 1,367 mm (53.8 in)	V. 2,821 mm (111.1 in)	W. 1,361 mm (53.6 in)
X. 201 mm (7.9 in)	Y. 31 mm (1.2 in)	Z. 209 mm (8.2 in)
AA. 197 mm (7.8 in)	AB. 1,176 mm (46.3 in)	AC. 2,558 mm (100.7 in)
AD. 1,374 mm (54.1 in)	AE. 1,025 mm (40.4 in)	AF. 1,588 mm (62.5 in)
AG. 2,205 mm (86.8 in)	AH. 514 mm (20.2 in)	AJ. 479 mm (18.9 in)
AK. 605 mm (23.8 in)		

Slide Door Exterior Dimensions

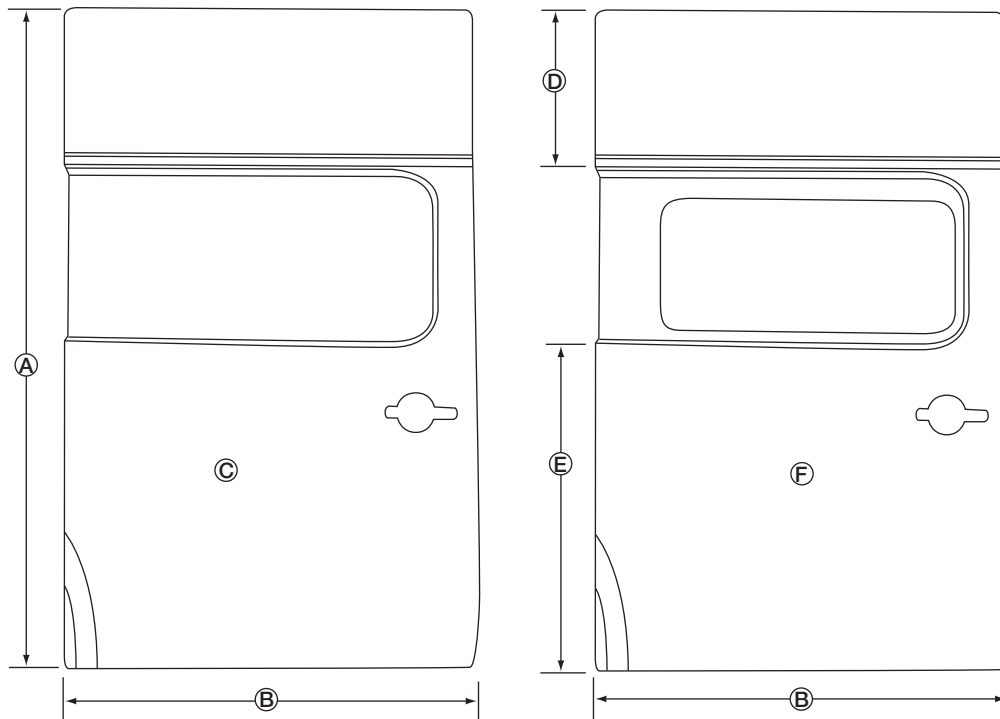

AAZIA0185GB

A. 2,096 mm (82.5 in)

B. 1,386 mm (54.6 in)

D. 519 mm (20.4 in)

E. 1,009 mm (39.7 in)

C. Slide door without glass —
surface area: 2.9 m² (31.3 ft²)
F. Slide door with glass — sur-
face area: 2.1 m² (22.8 ft²)

Front Roof Exterior Dimensions

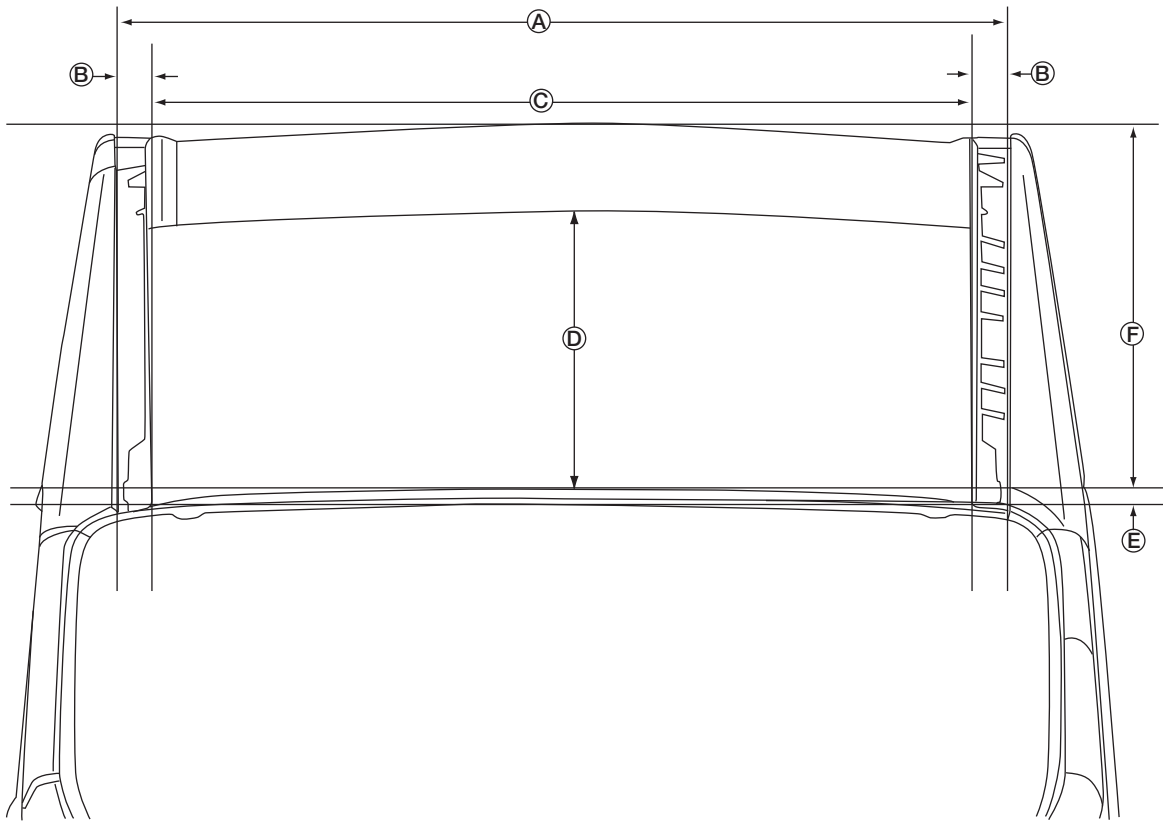

AAZIA0182GB

A. 1,540 mm (60.6 in)
D. 647 mm (25.5 in)

B. 60 mm (2.4 in)
E. 24 mm (0.9 in)

C. 1,419 mm (55.9 in)
F. 647 mm (25.5 in)

Hood Surface Exterior Dimensions

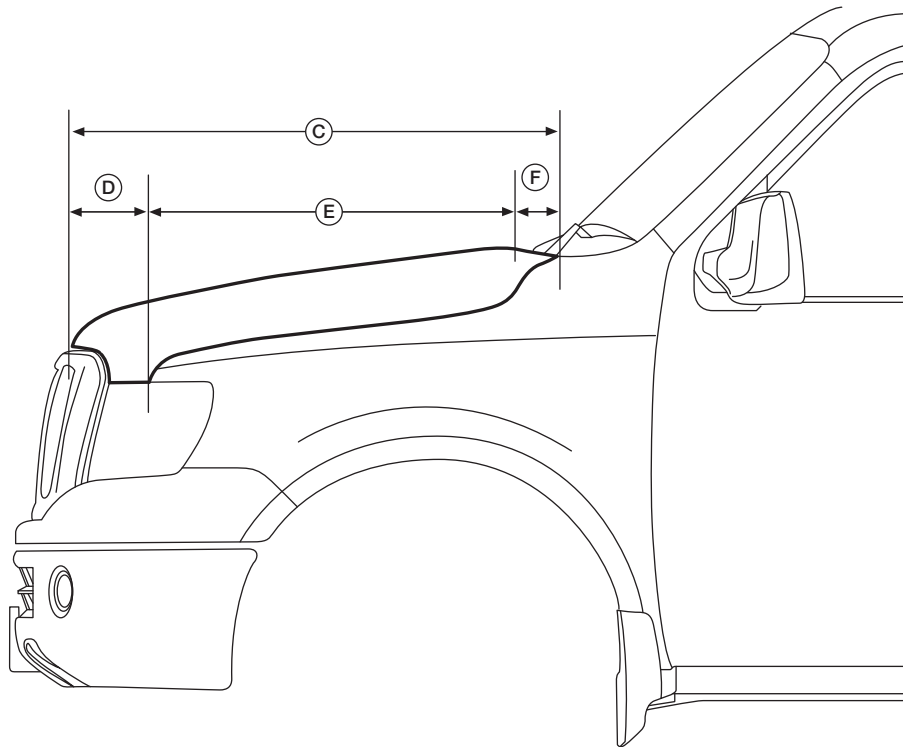
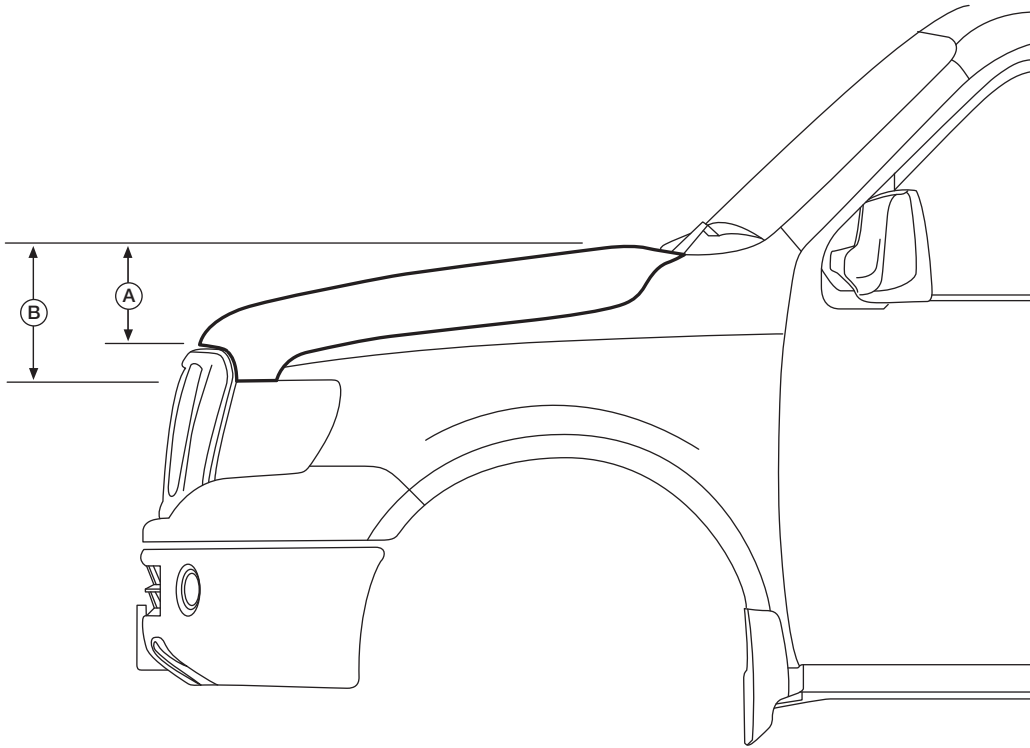

A. 256 mm (10.1 in)
D. 210 mm (8.3 in)

B. 348 mm (13.7 in)
E. 915 mm (36 in)

C. 1,249 mm (49.2 in)
F. 124 mm (5.5 in)

AAZIA0031ZZ

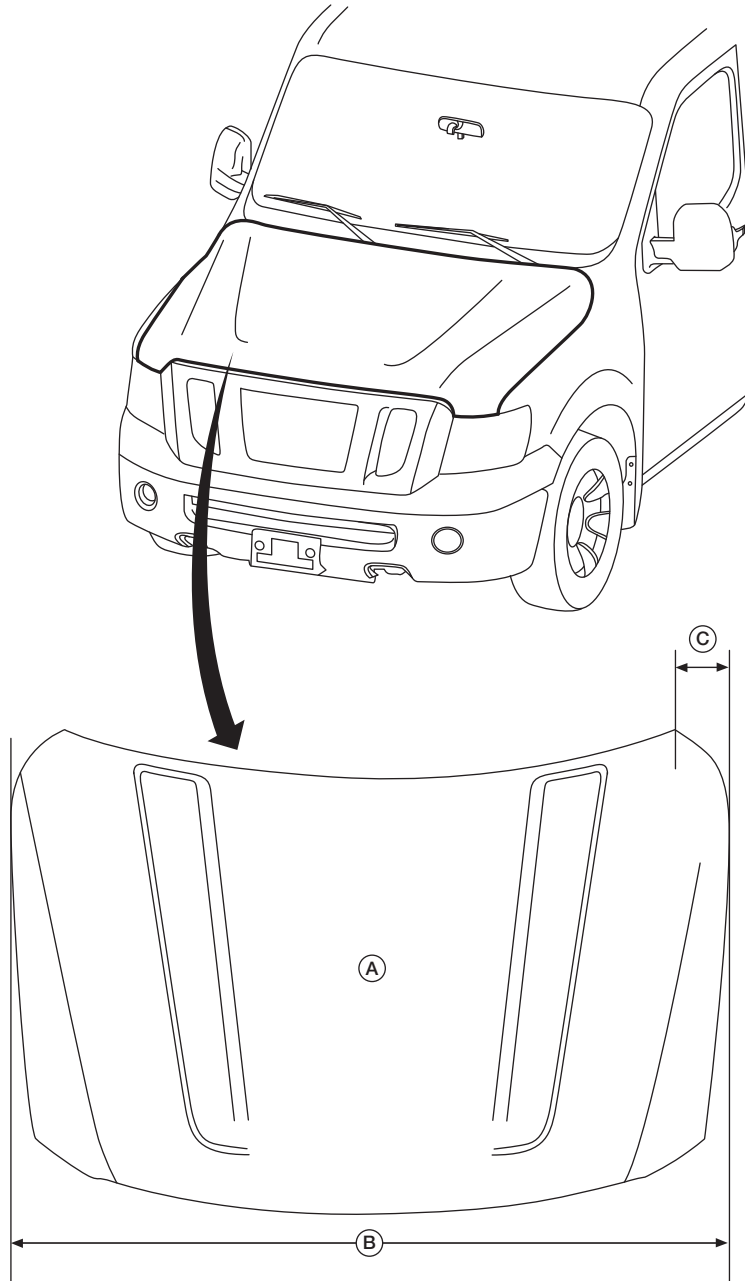

AAZIA003ZZZ

A. Flat surface area: 2.213 m²
(23.82 ft²)

B. 1,848 mm (72.7 in)

C. 140 mm (5.5 in)

Front Driver Door Sign Area

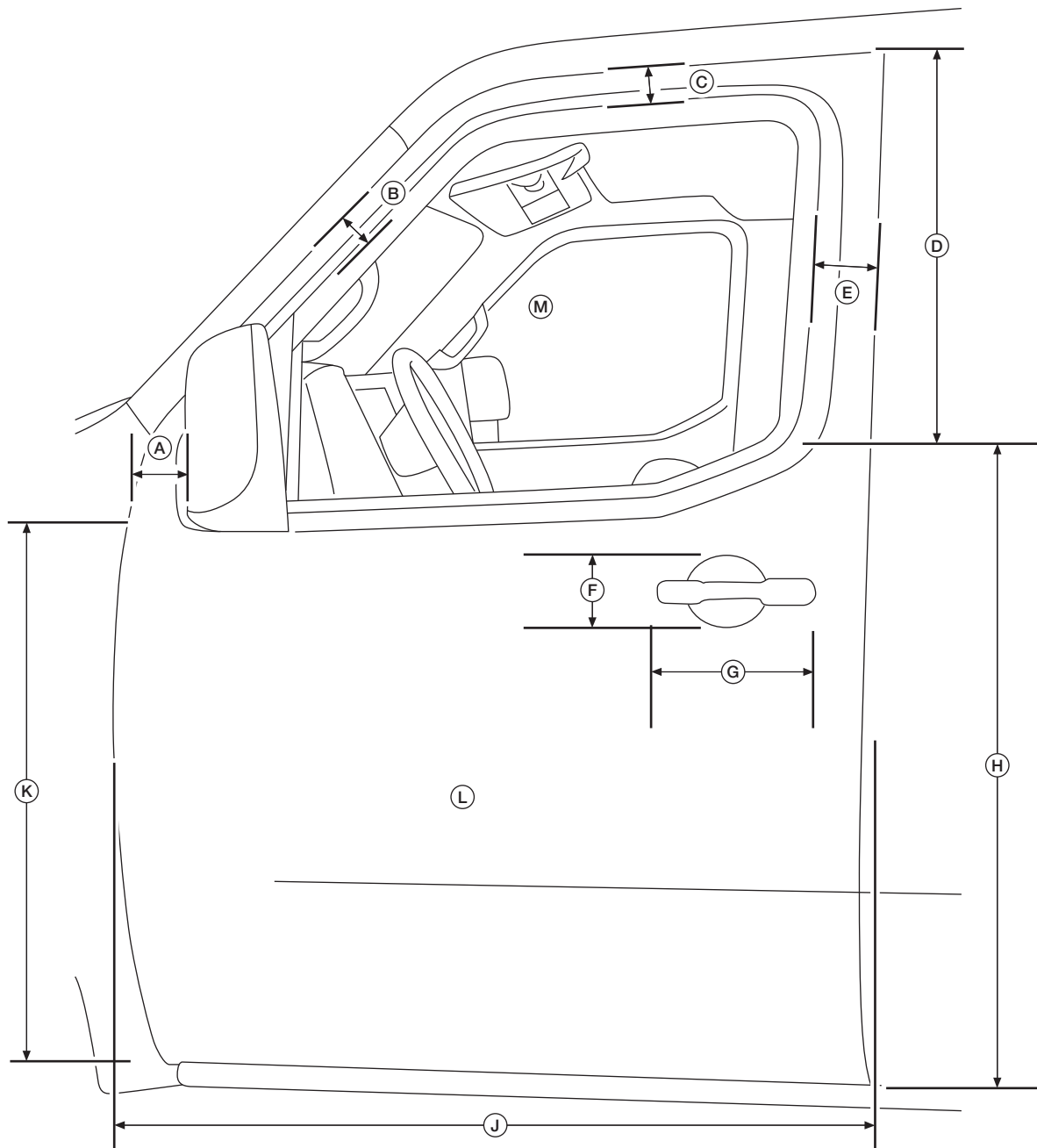

AAZIA0536ZZ

A. 79 mm (3.1 in)
 D. 563 mm (22.2 in)
 G. 226 mm (8.9 in)
 K. 763 mm (30 in)
 L. Full Door Surface area: 1.384
 m² (15 ft²)
 M. Glass and Mirror Surface
 area: .3940 m² (4.2 ft²)

B. 57 mm (2.2 in)
 E. 89 mm (3.5 in)
 H. 913 mm (36 in)

C. 57 mm (2.2 in)
 F. 120 mm (4.8 in)
 J. 1,042 mm (41 in)

Front Passenger Door Sign Area

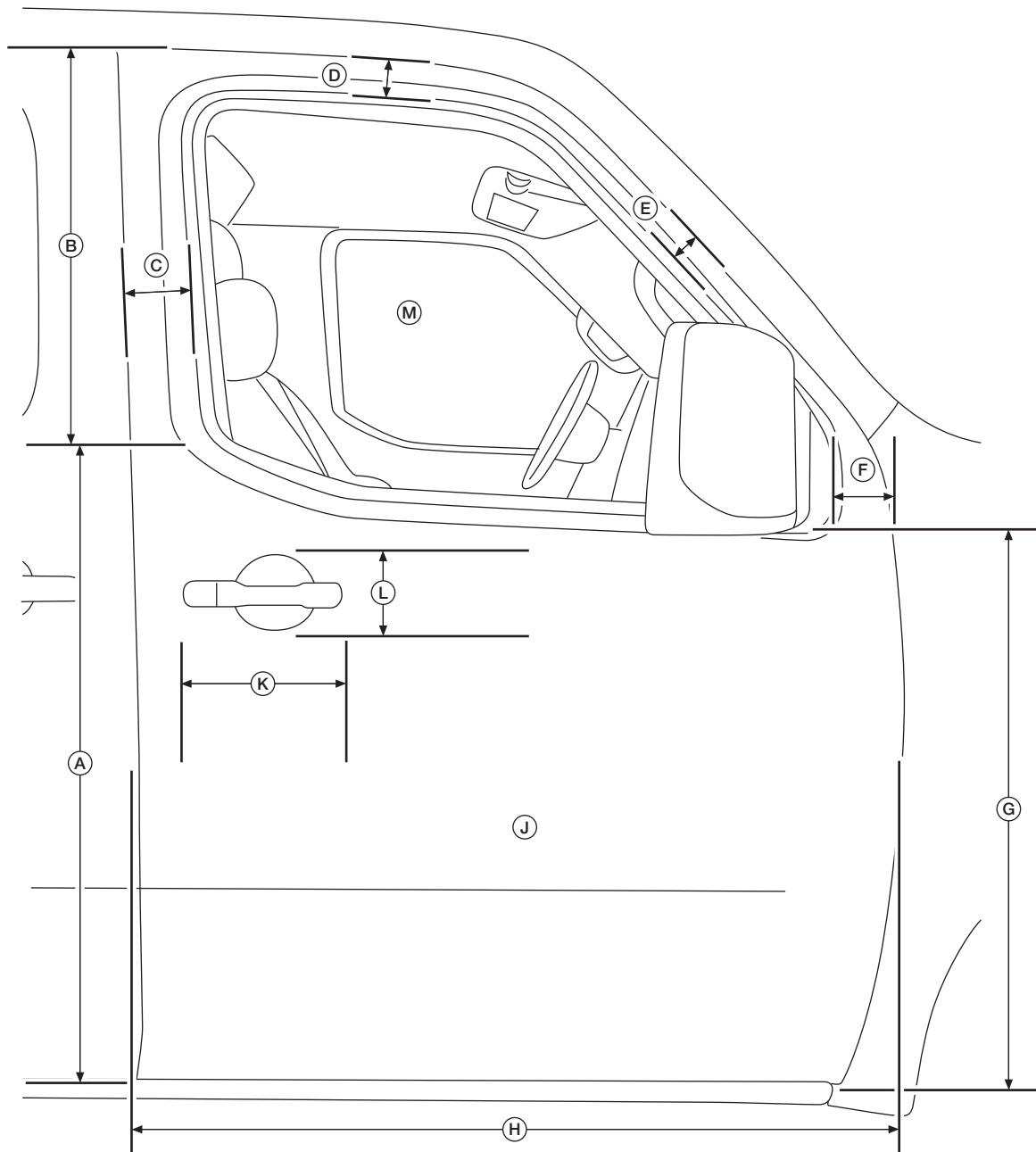

AAZIA0538ZZ

A. 913 mm (36 in)

D. 57 mm (2.2 in)

G. 763 mm (30 in)

J. Full Door Surface area: 1.384
m² (15 ft²)

L. 120 mm (4.8 in)

B. 563 mm (22.2 in)

E. 57 mm (2.2 in)

H. 1,042 mm (41 in)

K. 226 mm (8.9 in)

M. Glass and Mirror Surface
area: .3940 m² (4.2 ft²)

C. 89 mm (3.5 in)

F. 79 mm (3.1 in)

Back Door Sign Area

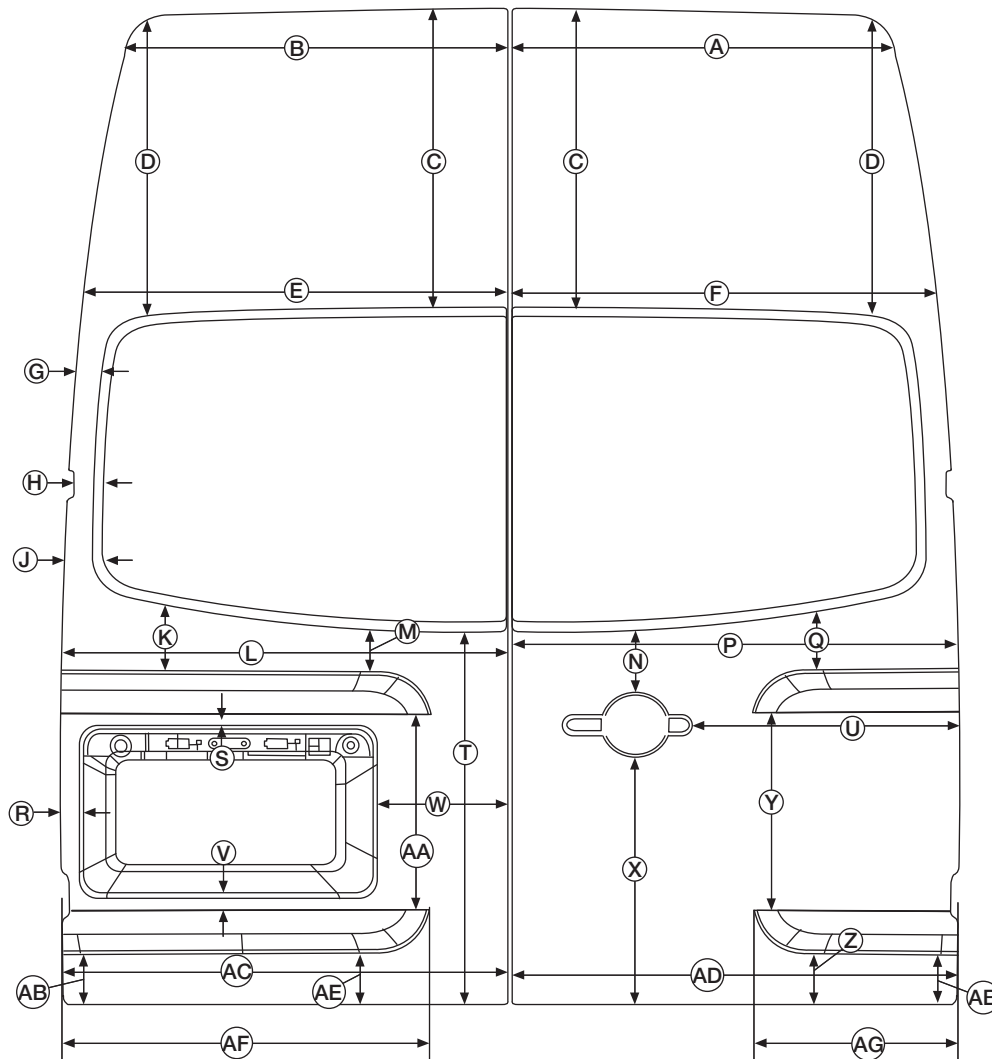

AAZIA0074ZZ

A. 729 mm (28.7 in)
 D. 600 mm (23.6 in)
 G. 57 mm (2.2 in)
 K. 136 mm (5.4 in)
 N. 127 mm (5 in)
 R. 36 mm (1.4 in)
 U. 514 mm (20.2 in)
 X. 483 mm (19 in)
 AA. 381 mm (15 in)
 AD. 849 mm (33.4 in)
 AG. 395 mm (15.6 in)

B. 727 mm (28.6 in)
 E. 810 mm (31.9 in)
 H. 39 mm (1.5 in)
 L. 848 mm (33.4 in)
 P. 851 mm (33.5 in)
 S. 26 mm (1 in)
 V. 28 mm (1.1 in)
 Y. 387 mm (15.2 in)
 AB. 98 mm (3.9 in)
 AE. 103 mm (4 in)

C. 601 mm (23.7 in)
 F. 812 mm (32 in)
 J. 61 mm (2.4 in)
 M. 87 mm (3.4 in)
 Q. 123 mm (4.8 in)
 T. 734 mm (28.9 in)
 W. 246 mm (9.7 in)
 Z. 100 mm (3.9 in)
 AC. 846 mm (33.3 in)
 AF. 706 mm (27.8 in)

Back Door Window Opening Sign Area

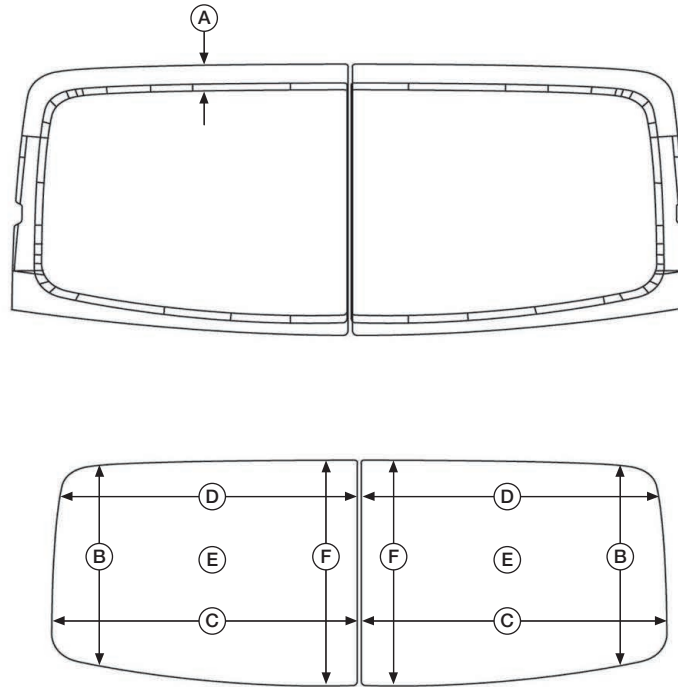

A. 52 mm (2 in)
D. 755 mm (29.7 in)

B. 523 mm (20.6 in)
E. Surface area: 0.4 m² (4.7 ft²)

C. 773 mm (30.4 in)
F. 602 mm (23.7 in)

AAZIA0014ZZ

PLACARDS

To find information and regulations about the placards, refer to the following website:

www.fmcsa.dot.gov

EXTERIOR

Front Door Opening Measurements

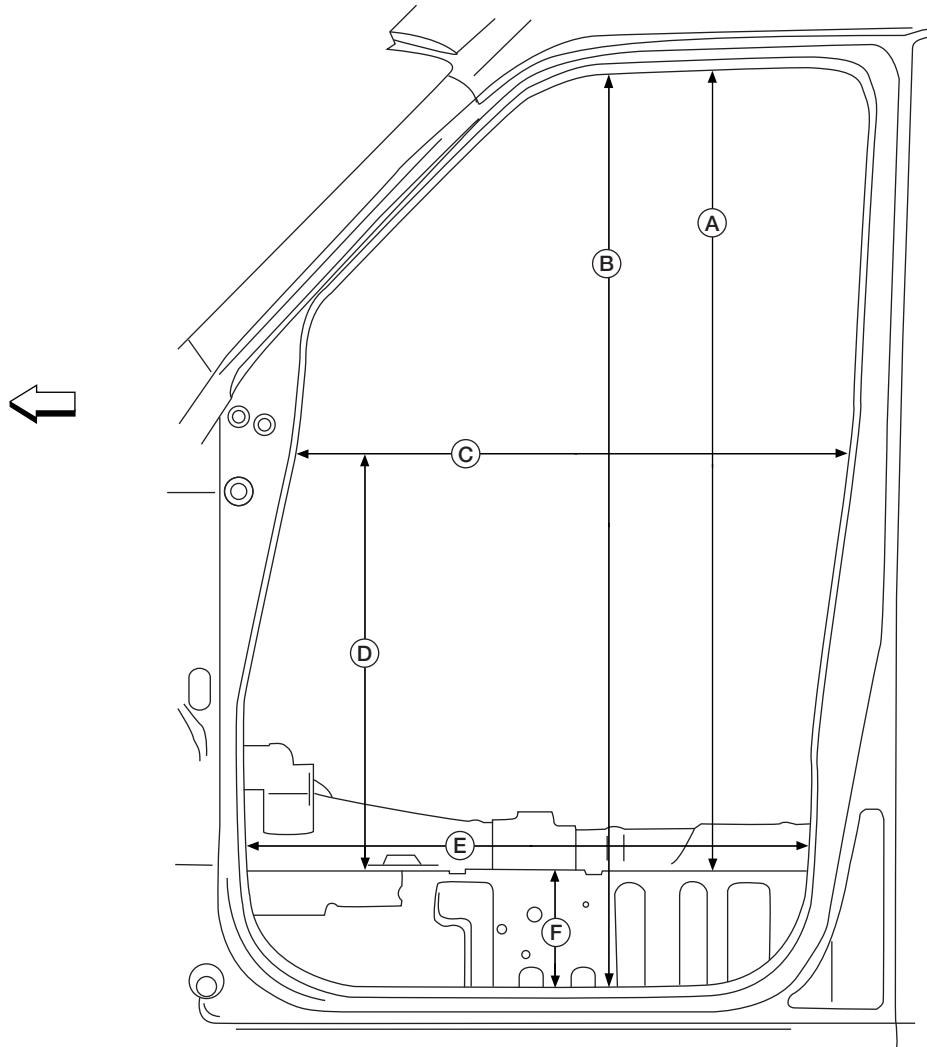

AAZIA0369ZZ

↔: Front of vehicle.

Without Door Seal and Interior Trim

- | | | |
|------------------------|------------------------|----------------------|
| A. 1,268 mm (49.92 in) | B. 1,494 mm (58.82 in) | C. 896 mm (35.28 in) |
| D. 708 mm (27.87 in) | E. 912 mm (35.91 in) | F. 230 mm (9.06 in) |

With Door Seal and Interior Trim

- | | | |
|------------------------|------------------------|----------------------|
| A. 1,258 mm (49.53 in) | B. 1,484 mm (58.43 in) | C. 888 mm (34.96 in) |
| D. 700 mm (27.56 in) | E. 902 mm (35.51 in) | F. 195 mm (7.68 in) |

Slide Door Opening Measurements – Without Slide Door Installed

Standard Roof

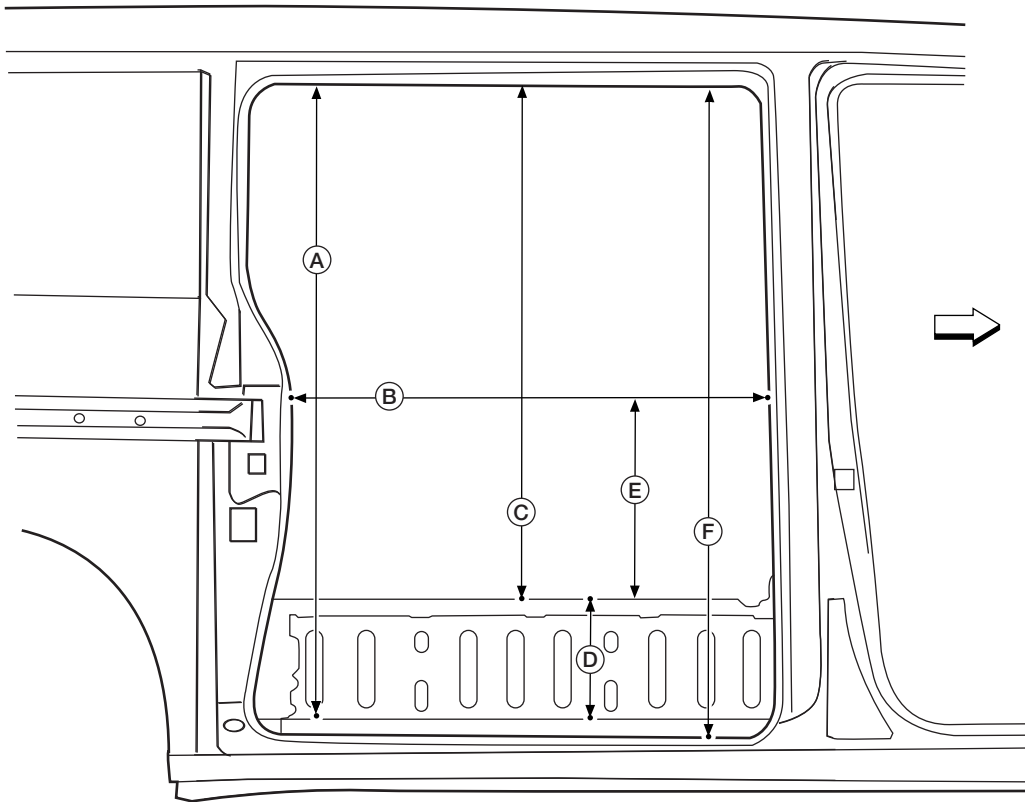

AAZIA0367ZZ

←: Front of vehicle.

Without Door Seal and Interior Trim

A. 1,450 mm (57.09 in)	B. 1,115 mm (43.90 in)	C. 1,232 mm (48.50 in)
D. 221 mm (8.70 in)	E. 450 mm (17.72 in)	F. 1,512 mm (59.53 in)

With Door Seal and Interior Trim

A. 1,432 mm (56.38 in)	B. 1,106 mm (43.54 in)	C. 1,229 mm (48.39 in)
D. 218 mm (8.58 in)	E. 450 mm (17.72 in)	F. 1,502 mm (59.13 in)

High Roof

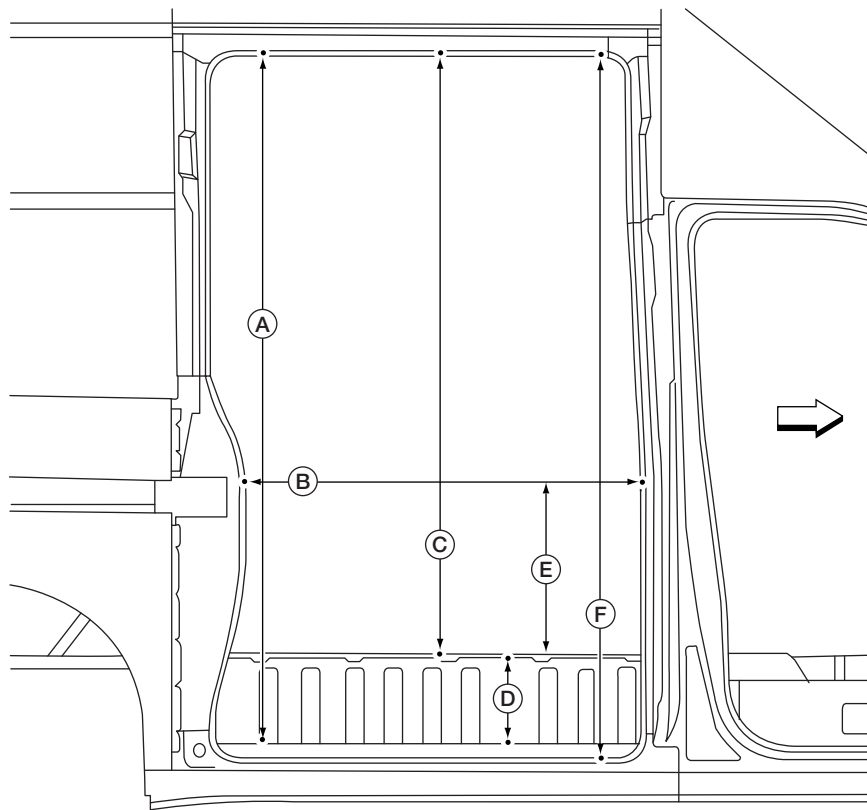

AAZIA0370ZZ

↔: Front of vehicle.

Without Door Seal and Interior Trim

A. 1,920 mm (75.59 in)	B. 1,114 mm (43.86 in)	C. 1,695 mm (66.73 in)
D. 221 mm (8.70 in)	E. 450 mm (17.72 in)	F. 1,985 mm (78.15 in)

With Door Seal and Interior Trim

A. 1,904 mm (74.96 in)	B. 1,104 mm (43.46 in)	C. 1,680 mm (66.14 in)
D. 218 mm (8.58 in)	E. 450 mm (17.72 in)	F. 1,975 mm (77.76 in)

Slide Door Opening Measurements – With Slide Door Installed

Standard Roof

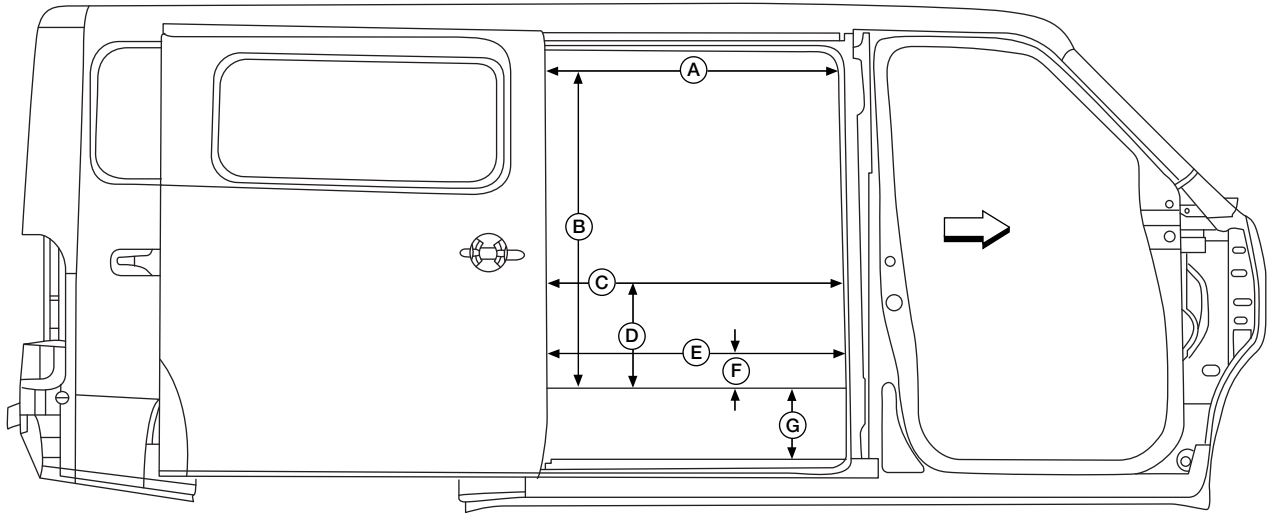

AAZIA0368ZZ

←: Front of vehicle.

Without Door Seal and Interior Trim

- | | | |
|------------------------|------------------------|------------------------|
| A. 1,064 mm (41.89 in) | B. 1,141 mm (44.92 in) | C. 1,096 mm (43.15 in) |
| D. 374 mm (14.72 in) | E. 1,073 mm (42.24 in) | F. 168 mm (6.61 in) |
| G. 218 mm (8.58 in) | | |

With Door Seal and Interior Trim

- | | | |
|------------------------|------------------------|------------------------|
| A. 1,060 mm (41.73 in) | B. 1,141 mm (44.92 in) | C. 1,092 mm (42.99 in) |
| D. 374 mm (14.72 in) | E. 1,069 mm (42.09 in) | F. 168 mm (6.61 in) |
| G. 218 mm (8.58 in) | | |

High Roof

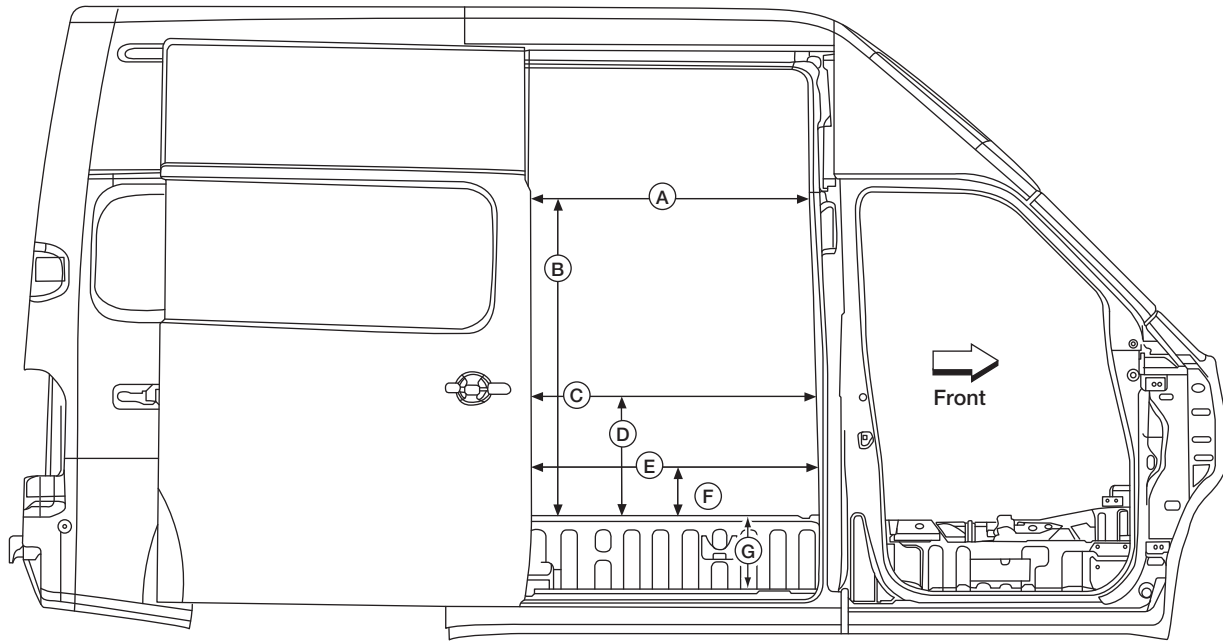

AAZIA0071ZZ

Without Door Seal and Interior Trim

- | | | |
|------------------------|------------------------|------------------------|
| A. 1,064 mm (41.89 in) | B. 1,141 mm (44.92 in) | C. 1,096 mm (43.15 in) |
| D. 374 mm (14.72 in) | E. 1,100 mm (43.31 in) | F. 168 mm (6.61 in) |
| G. 218 mm (8.58 in) | | |

With Door Seal and Interior Trim

- | | | |
|------------------------|------------------------|------------------------|
| A. 1,060 mm (41.73 in) | B. 1,141 mm (44.92 in) | C. 1,092 mm (42.99 in) |
| D. 374 mm (14.72 in) | E. 1,096 mm (43.15 in) | F. 168 mm (6.61 in) |
| G. 218 mm (8.58 in) | | |

Back Door Opening Measurements

Standard Roof

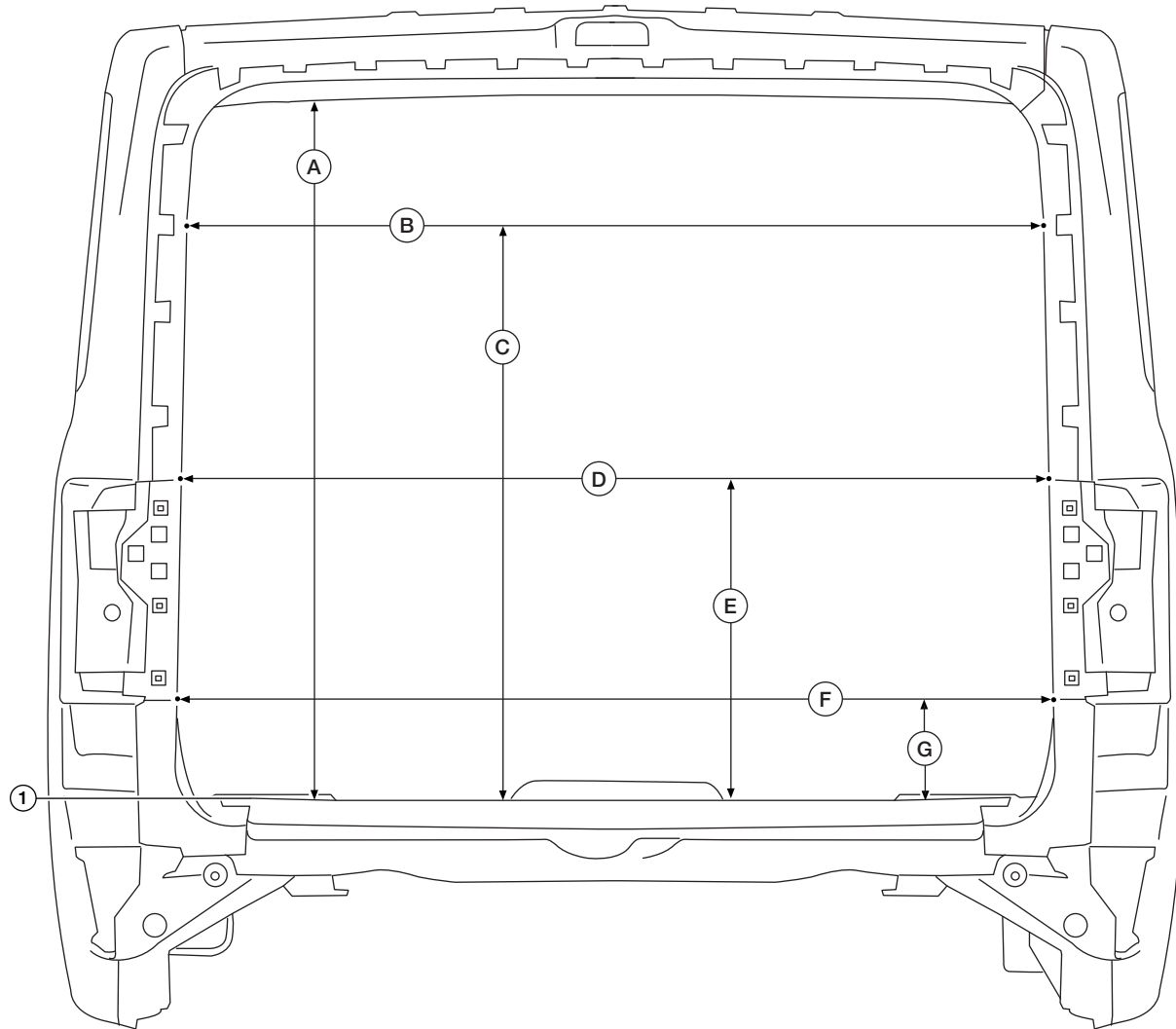

AAZIA0373ZZ

Without Door Seal and Cargo Mat

1. Sheet metal	A. 1,302 mm (51.26 in)	B. 1,528 mm (60.16 in)
C. 1,053 mm (41.46 in)	D. 1,560 mm (61.42 in)	E. 600 mm (23.62 in)
F. 1,572 mm (61.89 in)	G. 170 mm (6.69 in)	

With Door Seal and Cargo Mat

1. Sill trim	A. 1,290 mm (50.79 in)	B. 1,528 mm (60.16 in)
C. 1,035 mm (40.75 in)	D. 1,552 mm (61.10 in)	E. 600 mm (23.62 in)
F. 1,564 mm (61.57 in)	G. 170 mm (6.69 in)	

High Roof

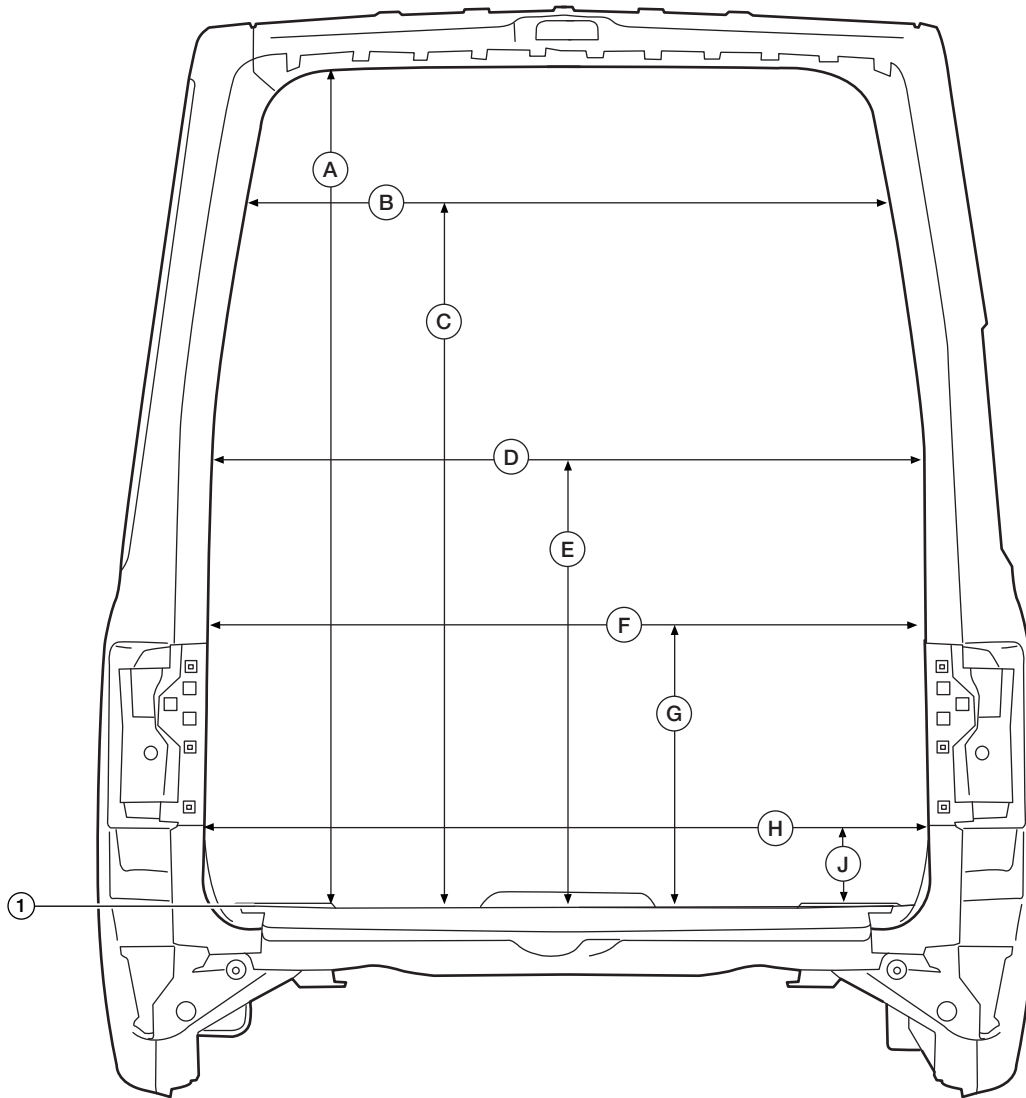

AAZIA0372ZZ

Without Door Seal and Cargo Mat

1. Sheet metal	A. 1,845 mm (72.64 in)	B. 1,370 mm (53.94 in)
C. 1,646 mm (64.80 in)	D. 1,537 mm (60.51 in)	E. 1,053 mm (41.46 in)
F. 1,562 mm (61.50 in)	G. 600 mm (23.62 in)	H. 1,567 mm (61.69 in)
J. 170 mm (6.69 in)		

With Door Seal and Cargo Mat

1. Sill trim	A. 1,822 mm (71.73 in)	B. 1,364 mm (53.70 in)
C. 1,628 mm (64.09 in)	D. 1,531 mm (60.28 in)	E. 1,035 mm (40.75 in)
F. 1,556 mm (61.26 in)	G. 600 mm (23.62 in)	H. 1,561 mm (61.46 in)
J. 170 mm (6.69 in)		

Doors and Mirrors Dimensions
Overhead View

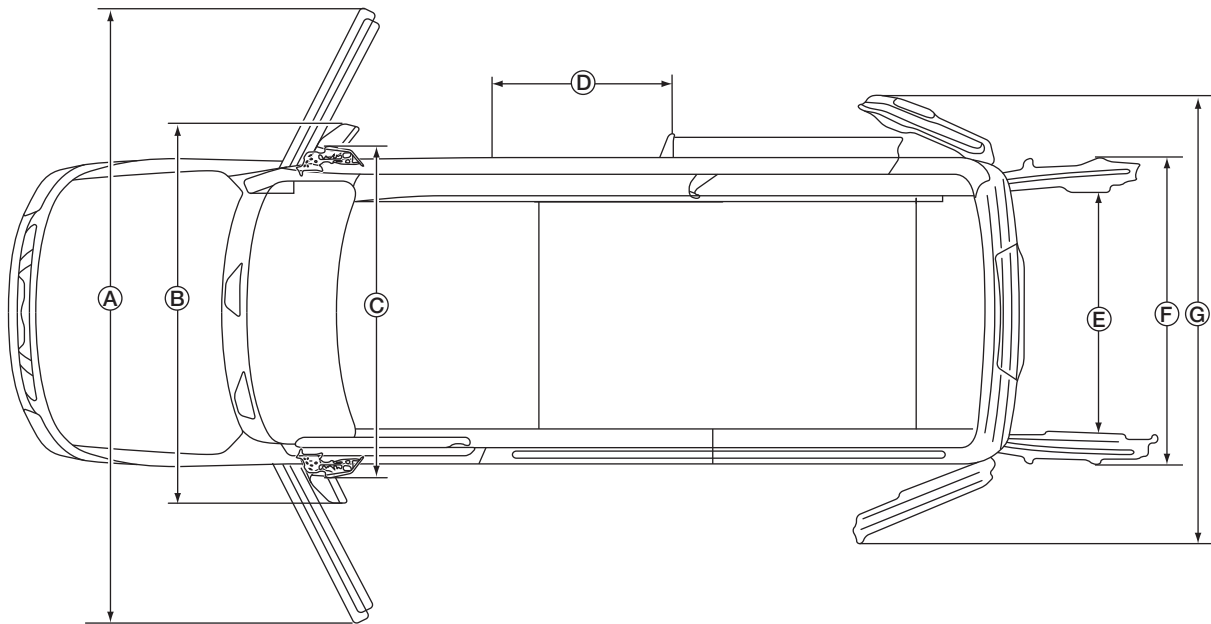

AAZIA0059ZZ

A. 4,055 mm (159.6 in)

B. With Tow Mirrors Extended:
2,758 mm (108.6 in)
With Tow Mirrors Non-Extended:
2,610 mm (102.8 in)
Without Tow Mirrors:
2,466 mm (97.09 in)

C. With Mirrors Folded:
2,179 mm (85.8 in)

D. 1,044 mm (41.1 in)

E. 1,974 mm (77.7 in)

F. 1,985 mm (78.15 in)

G. 2,918 mm (114.9 in)

Exterior Overall Dimensions

Standard Roof

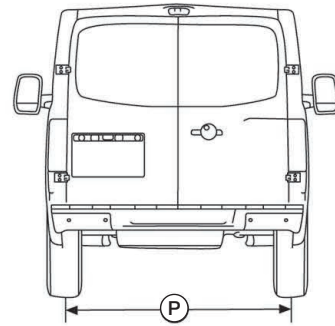
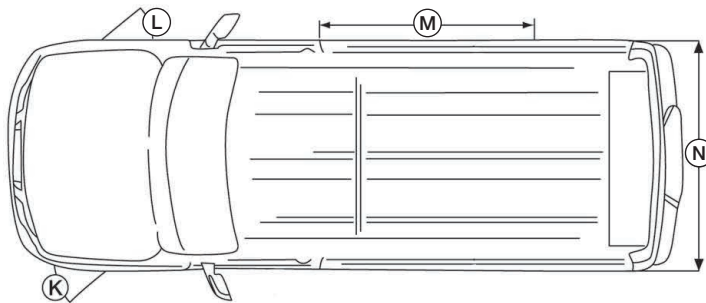
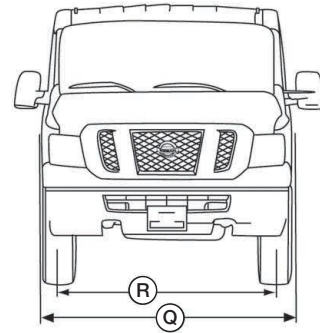
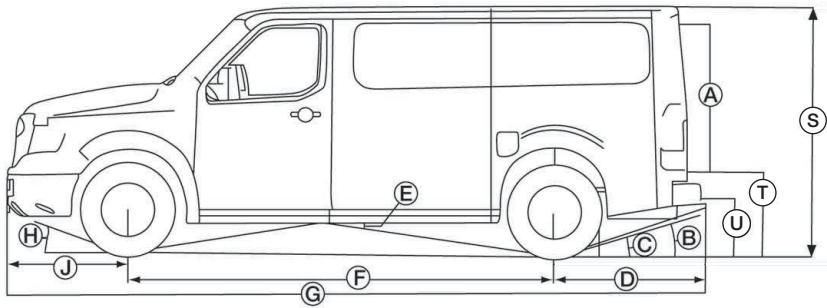

AAZIA0006ZZ

- A. 1,244 mm (49 in)
- D. 1,339 mm (52.7 in)
- G. 6,112 mm (240.6 in)
- K. 39.42°
- N. 2,030 mm (79.9 in)
- R. 1,745 mm (68.7 in)
- U. 502 mm (19.8 in)

- B. 17.4°
- E. 16.2°
- L. 35.19°
- P. 1,750 mm (68.9 in)
- S. 1500/2500 model:
2,131 mm (83.9 in)
- 3500 model:
2,156.5 mm (84.9 in)

- C. 18.4°
- F. 3,710 mm (146.1 in)
- J. 1,063 mm (41.9 in)
- M. 1,065 mm (41.9 in)
- Q. 2,030 mm (79.9 in)
- T. 725 mm (28.5 in)

Exterior Overall Dimensions

High Roof

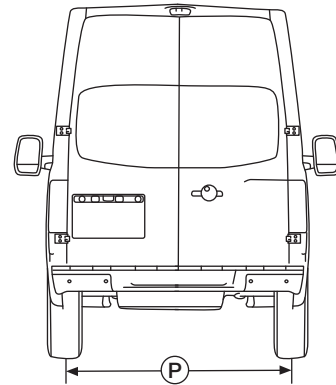
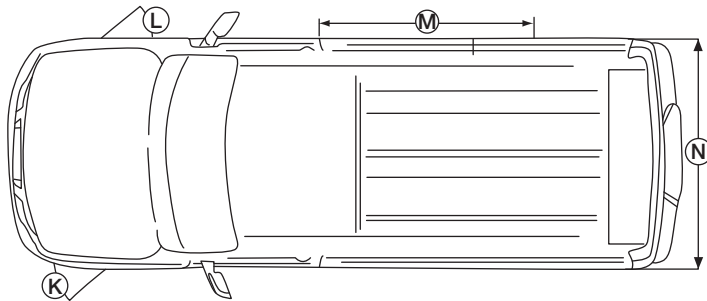
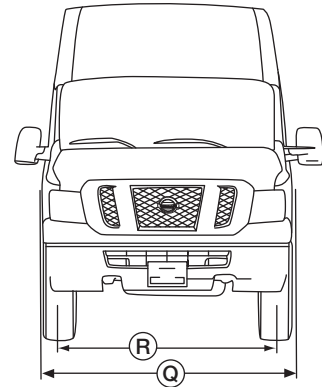
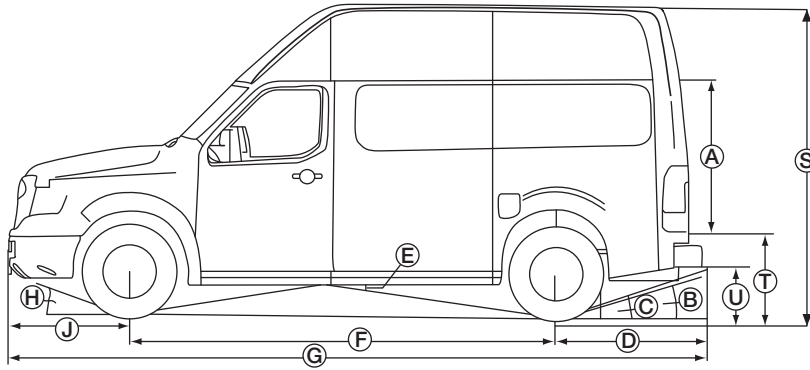

AAZIA0072ZZ

- A. 1,244 mm (49.0 in)
- D. 1,339 mm (52.7 in)
- G. 6,112 mm (240.6 in)
- K. 39.42°
- N. 2,030 mm (79.9 in)
- R. 1,745 mm (68.7 in)

- B. 17.4°
- E. 16.2°
- H. 17.5°
- L. 35.19°
- P. 1,750 mm (68.9 in)
- S. 2500 model:
2,667 mm (105.0 in)
- 3500 model:
2,692 mm (106.0 in)

- C. 18.4°
- F. 3,710 mm (146.1 in)
- J. 1,063 mm (41.9 in)
- M. 1,065 mm (41.9 in)
- Q. 2,030 mm (79.9 in)
- T. 725 mm (28.5 in)

U. 502 mm (19.8 in)

FRAME/BODY

Crossmember and Body Mount Dimensions

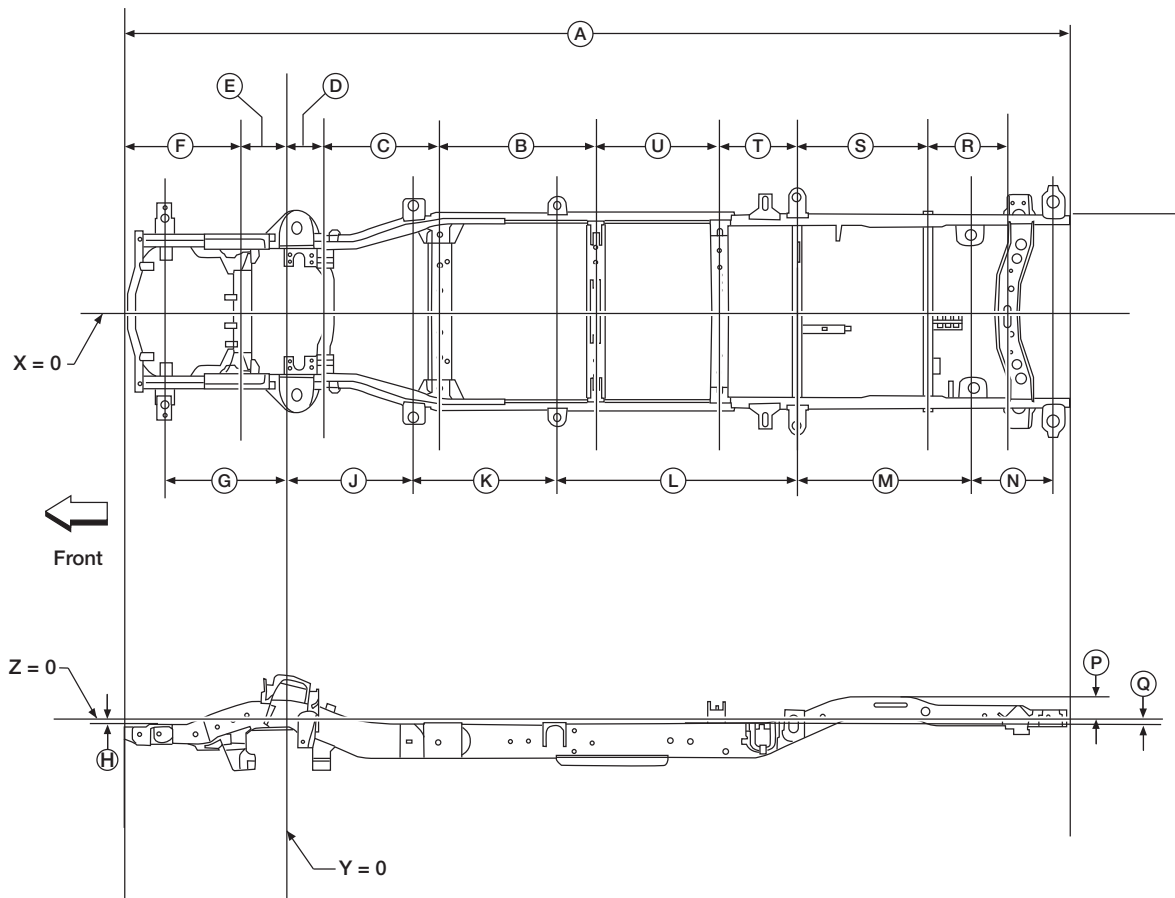

AAZIA0049ZZ

- | | | |
|-----------------------|-----------------------|-----------------------|
| A. 4,771 mm (1878 in) | B. 954 mm (376 in) | C. 706 mm (278 in) |
| D. 208 mm (8.2 in) | E. 310 mm (12.2 in) | F. 647 mm (25.5 in) |
| G. 775 mm (30.5 in) | H. 31 mm (1.2 in) | J. 748 mm (29.4 in) |
| K. 885 mm (34.8 in) | L. 1,467 mm (57.8 in) | M. 1,133 mm (44.6 in) |
| N. 440 mm (17.3 in) | P. 133 mm (5.2 in) | Q. 25 mm (0.98 in) |
| R. 777 mm (30.6 in) | S. 803 mm (31.6 in) | T. 483 mm (19.02 in) |
| U. 760 mm (29.9 in) | | |

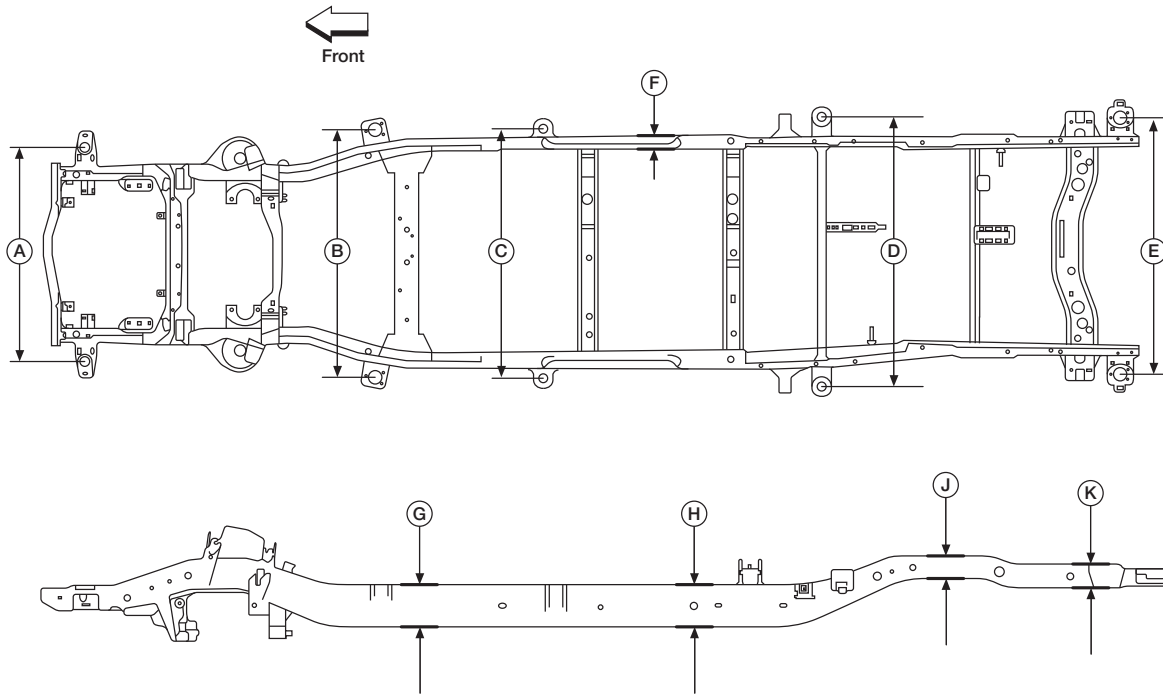

AAZIA0008ZZ

A. 1,123 mm (44.2 in)
 D. 1,385 mm (54.5 in)
 G. 216 mm (8.5 in)
 K. 124 mm (4.9 in)

B. 1,281 mm (50.4 in)
 E. 1,343 mm (52.9 in)
 H. 208 mm (8.2 in)

C. 1,281 mm (50.4 in)
 F. 72 mm (2.8 in)
 J. 121 mm (4.8 in)

ELECTRICAL

SELF-TEST MODE

This vehicle is capable of performing a function test of various systems on the vehicle.

To enter the Self-Test Mode

1. Close the hood and front door RH, and lift the wiper arms from the windshield (to prevent windshield damage due to wiper operation).

NOTE:

When this test mode is performed with hood opened, sprinkle water on windshield beforehand.

2. Ignition switch OFF.
3. Ignition switch ON and, within 20 seconds, press the front door switch LH 10 times. Then ignition switch OFF.
4. Ignition switch ON within 10 seconds. After that, the horn sounds once and the self test starts.

When the vehicle is in Self-Test Mode the following devices on the vehicle will momentarily operate in the order shown to verify that the systems are functioning correctly.

- Oil pressure low warning indicator
- Rear defogger (if equipped)
- Front wipers (HI, LO)
- Tail, license, side marker lamps and parking lamps
- Headlamps (HI, LO)
- Air conditioner compressor (magnetic clutch)
- Engine cooling fan

After the self-test has been completed (3 on/off cycles) the vehicle will be returned to normal operating mode.

NOTE:

Ignition switch OFF during the test will terminate the test early.

DATA LINK CONNECTOR LOCATION (FOR DIAGNOSTIC SCAN TOOL)

Consult Checking System

Vehicle model years 2012-2017 are equipped with a data link connector located underneath the instrument panel below the steering column.

1. Data Link Connector

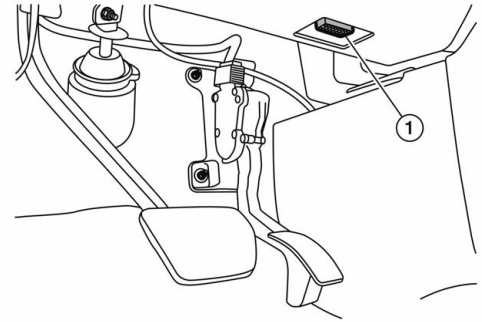

TGAAZIA0017ZZ

Starting with 2018 model year, vehicles are equipped with a data link connector located underneath the instrument panel near the hood release handle.

1. Data Link Connector

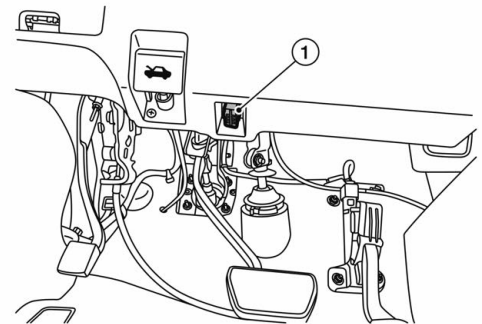

TGAAZIA0018ZZ

The vehicle is diagnosed using the CONSULT-III plus.

- When CONSULT is connected with a data link connector equipped on the vehicle side, it will communicate with the control unit equipped in the vehicle and then enable various kinds of diagnostic tests.
- Refer to "CONSULT-III plus Operation Manual" for more information.

TRANSIT AND SHIPPING (EXTENDED STORAGE) MODE CONTROL SYSTEMS

Determining Shipping (Extended Storage) Mode Status

1. Ignition switch ON.
2. Check that extended storage warning message is not displayed in instrument cluster or display.

If the extended storage warning message is displayed in instrument cluster or display refer to [Canceling Extended Storage \(pg. 218\)](#)

Determining Transit Mode Status – 2012-2016 Model Years

Use the table below to determine the transit mode status.

Status	Symptom
Transit Mode	When ignition switch is turned from OFF to ON, turn signal indicators will illuminate for 1 minute.
Normal Mode	When ignition switch is turned from OFF to ON, turn signal indicators stay OFF (do not illuminate).

If the turn signal indicators illuminate for 1 minute refer to [Transit Mode Canceling Procedure \(pg. 217\)](#)

Transit Mode Canceling Procedure – 2012-2016 Model Years

Transit mode can only be canceled. Once transit mode has been canceled, it cannot be activated again.

1. Ignition switch OFF.
2. Do the following at the same time for 2 seconds:
 - Turn and hold front wiper switch to HI position
 - Move turn signal switch to left position (all the way down)

SHIPPING MODE (EXTENDED) STORAGE SYSTEM CANCEL

Canceling Extended Storage

1. Ignition switch OFF.
2. Press in (turn on) the extended storage switch. Refer to [Extended Storage Switch \(pg. 218\)](#)
3. Ignition switch ON.
4. Ignition switch OFF and wait at least 2 seconds.

Extended Storage Switch

The following switch is mounted on the fuse block (Junction Box) for transportation and storage.

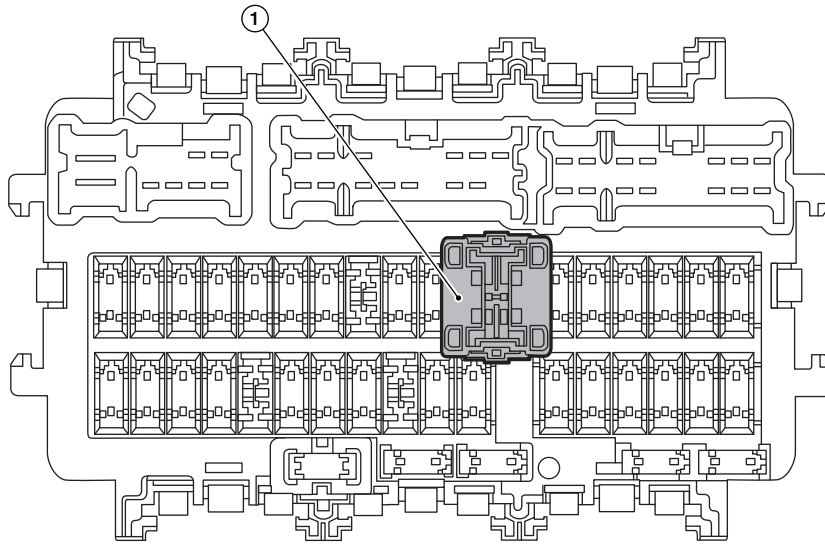

AAZIA0487ZZ

1. Extended storage switch

Remove the extended storage switch if it causes interference when checking fuses, refer to [How to remove the Extended Storage Switch \(pg. 220\)](#).

How to turn the Extended Storage Switch ON/OFF

**CAUTION:**

- Ignition switch OFF when operating the extended storage switch.
- Under normal conditions, keep the extended storage switch in ON state. Never operate the extended storage switch except when necessary.

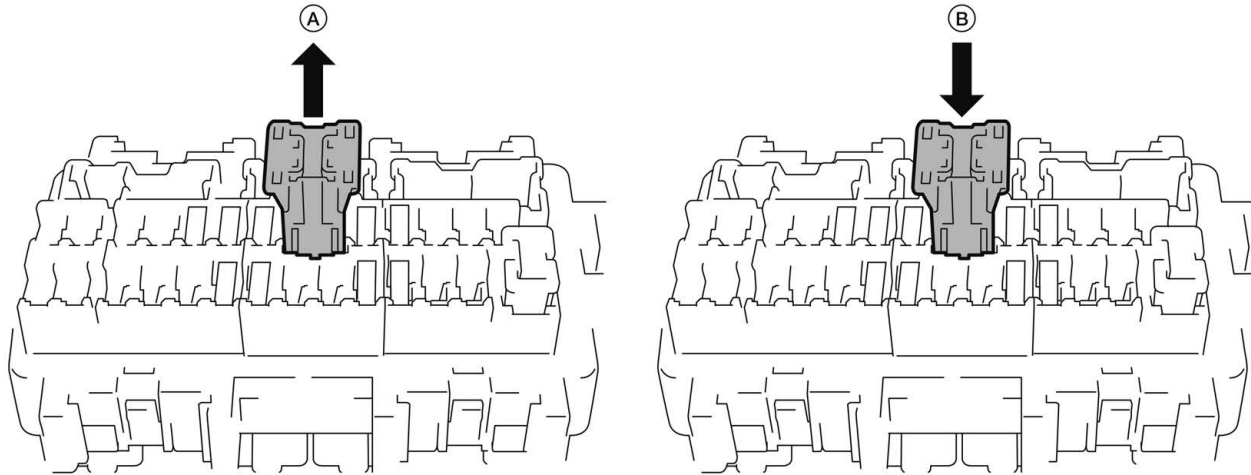

TGAZIA0035ZZ

- To turn the extended storage switch OFF, pull it up in direction A as shown in the figure.
- To turn the extended storage switch ON, press it in direction B as shown in the figure.

How to remove the Extended Storage Switch

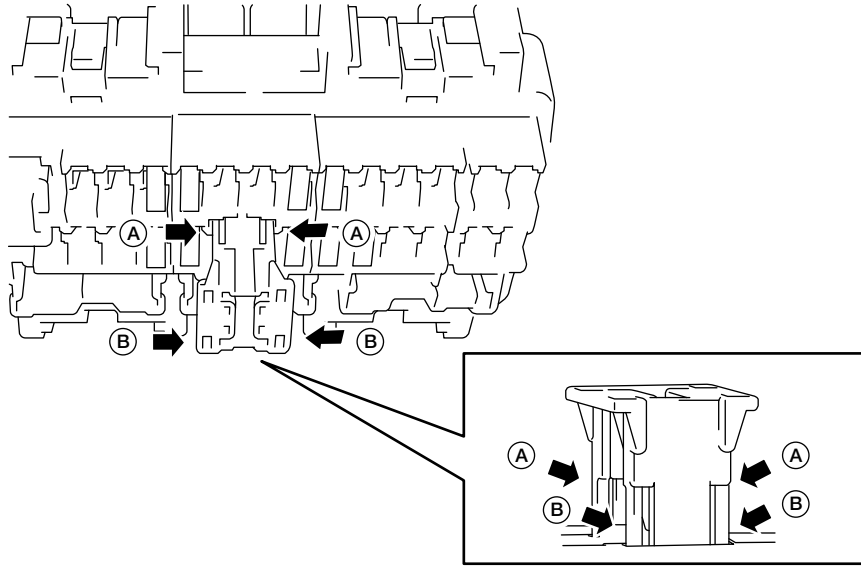

AAZIA0542ZZ

1. Ignition switch OFF.
2. Turn the extended storage switch OFF.
3. Pinch tabs A and tilt to disengage the extended storage switch. Pinch tabs B to remove the extended storage switch.

**CAUTION:**

For bus bar type extended storage switch, never replace bus bar with a fuse, or fuse may continually open.

NOTE:

- **Extended storage switch and fuse (or bus bar) are removed together. Remove fuse (or bus bar) from extended storage switch, if necessary.**
- **Install removed fuse (or bus bar) to fuse block.**
- **Extended storage switch is for transportation and storage. Reinstallation of switch is not required after removal, but fuse (or bus bar) must be reinstalled/pushed back in to activate all electrical systems and turn message off (which may be shown in meter/display).**

FUSE AND RELAY INFORMATION

Fuses and Relays — Engine Compartment



WARNING:

This information is reference only. To avoid damage, modification of the vehicle's electrical systems is not recommended. For pre-wiring access points, refer to **CUSTOMER PRE-WIRING ACCESS. (pg. 231)**

1	F1	RR DEF	15A	F13	H/LAMP HI LH	10A	13
2	F2	RR DEF	15A	F14	H/LAMP HI RH	10A	14
3	F3	DTRL RLY SUPPLY	10A	F15	INJECTOR	15A	15
4	F4	TRAILER TOW	10A	F16	TTOW REV LAMP	10A	16
5	F5	HEATED MIRROR	15A	F17	O2 SENS IGN	15A	17
6	F6	FR WIPER	30A	F18	FUEL PUMP	15A	18
7	F7	TAIL	10A	F19	A/T ECU IGN	10A	19
8	F8	A/C CLUTCH	10A	F20	ABS ECU IGN	10A	20
9	F9	CLEARANCE/L	10A	F21	REV LAMP IGN	10A	21
10	F10	FR FOG LAMP	15A	F22	SPARE	30A	22
11	F11	H/LAMP LO LH	15A	F23	ETC	20A	23
12	F12	H/LAMP LO RH	15A	F24	EGI	20A	24

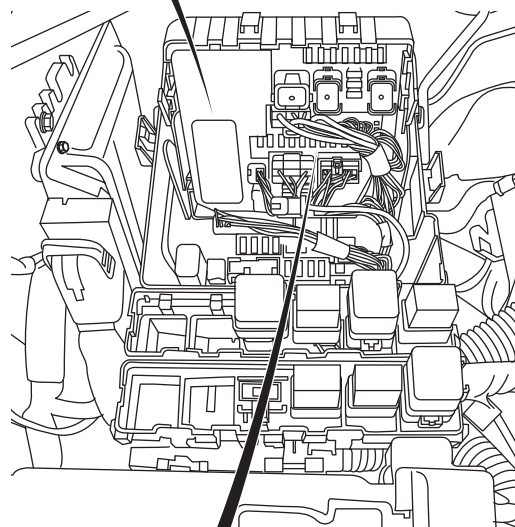
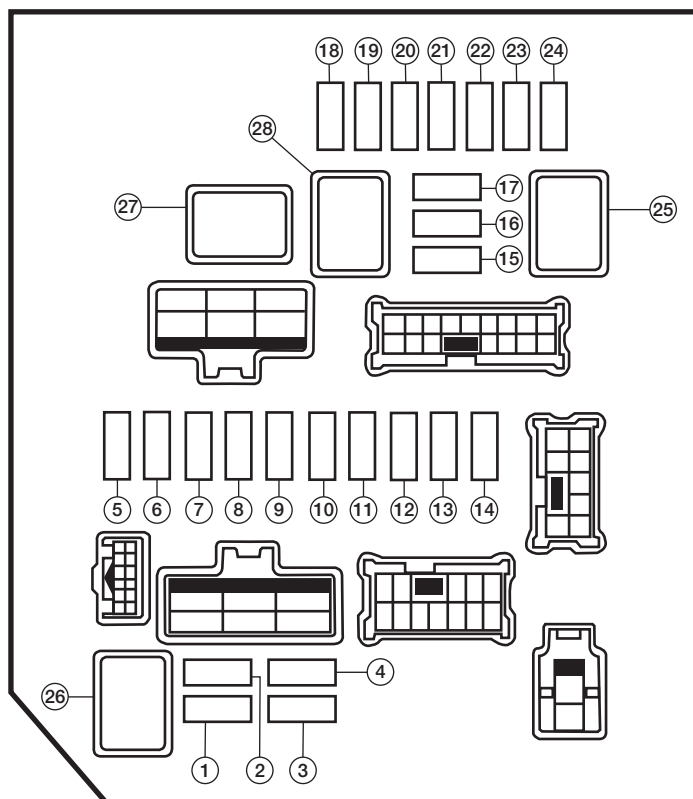

AAZIA0088ZZ

NOTE:

This fuse panel is the intelligent power distribution module engine room (IPDM E/R).

FUSE AND RELAY INFORMATION

[ELECTRICAL]

Item	Fuse/Relay Color	Fuse Rating	Power Supply Condition	Fuse/Relay Name
1	Blue	15A	Battery	Rear window defogger relay
2	Blue	15A	Battery	Rear window defogger relay
3	Red	10A	Battery	Daytime light system
4	Red	10A	Battery	Trailer tow
5	Blue	15A	Battery	Rear window/door mirror defrost
6	Green	30A	Battery	Front wiper relay
7	Red	10A	Battery *1	Parking, license plate and tail lamps (trailer tow)
8	Red	10A	Battery	A/C control, engine control
9	Red	10A	Battery *1	Illumination, parking, license plate and tail lamps
10	Blue	15A	—	Not used
11	Blue	15A	Battery *2	Daytime light system, headlamp (low LH)
12	Blue	15A	Battery *2	Daytime light system, headlamp (low RH)
13	Red	10A	Battery *3	Daytime light system, headlamp (high LH)
14	Red	10A	Battery *3	Daytime light system, headlamp (high RH)
15	Blue	15A	Ignition, Start	Engine control system (injector)
16	Red	10A	Ignition, Start	Sonar system, back-up lamp (trailer tow)
17	Blue	15A	Ignition, Start	Engine control system (O ₂ sensor)
18	Blue	15A	Ignition, Start	Fuel pump
19	Red	10A	Ignition, Start	A/T control system
20	Red	10A	Ignition, Start	ABS control, stop lamp control (trailer tow)
21	Red	10A	Ignition, Start	Back-up lamp control (trailer tow), sonar system
22	Green	30A	—	Spare
23	Yellow	20A	Battery	Throttle control motor relay
24	Yellow	20A	Battery	ECM relay
25	Black	—	—	Ignition relay
26	Black	—	—	Rear window defogger relay
27	Black	—	—	Cooling fan relay - 1
28	Black	—	—	Cooling fan relay - 2

*1: With tail lamps ON.

*2: With low beam headlamps ON.

*3: With high beam headlamps ON.

FUSE AND RELAY INFORMATION

[ELECTRICAL]

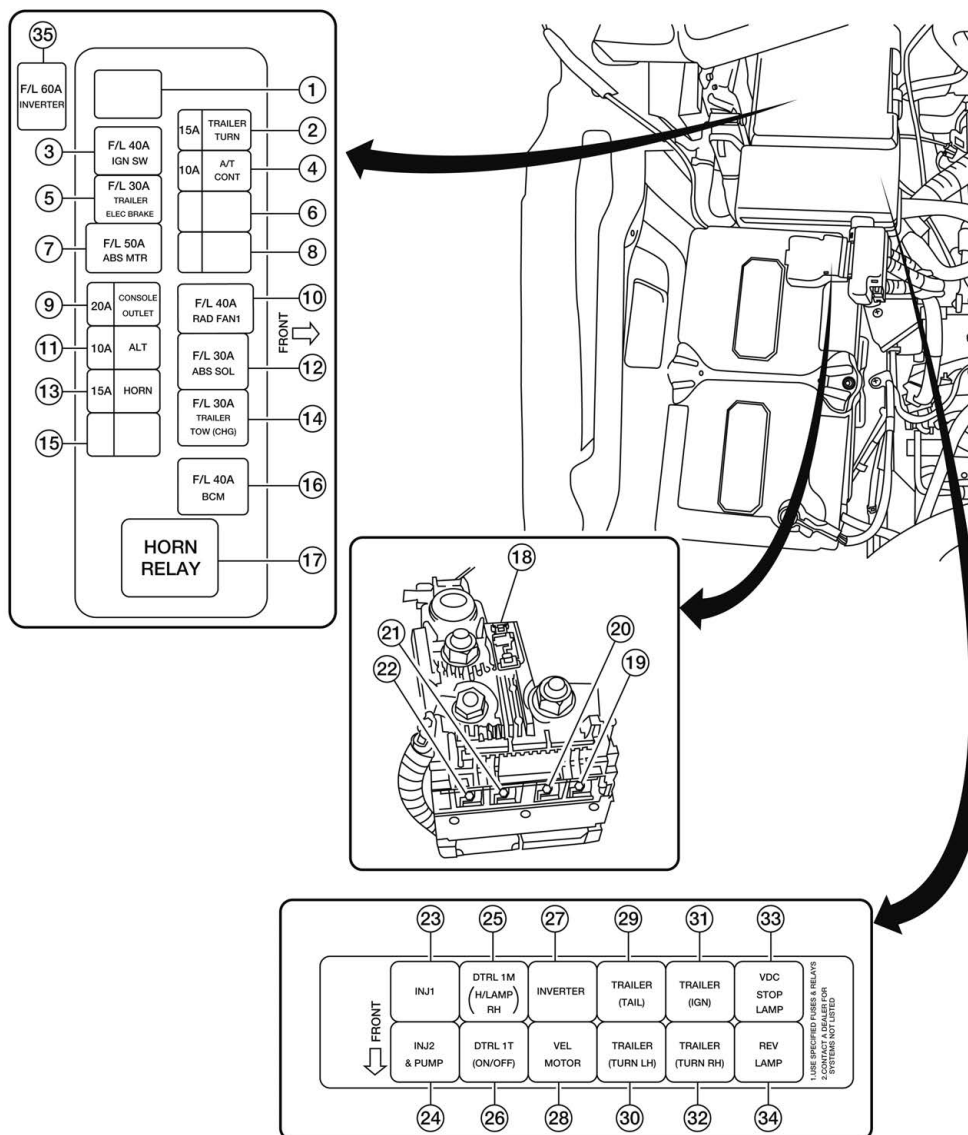

AAZIA0885ZZ

Item	Fuse/Relay Color	Fuse Rating	Power Supply Condition	Fuse/Relay Name
1	—	—	—	Not used
2	Blue	15A	Battery	Turn signal control (trailer tow)
3	Orange	40A	Battery	Starting system
4	Red	10A	Battery	Automatic transmission control system
5	Green	30A	Battery	Electric brake (trailer tow)
6	—	—	—	Not used
7	Red	50A	Battery	ABS Control
8	—	—	—	Not used
9	Yellow	20A	Battery	Console 12V power socket
10	Orange	40A	Battery	Engine cooling fan system

FUSE AND RELAY INFORMATION

[ELECTRICAL]

Item	Fuse/ Relay Color	Fuse Rating	Power Supply Condition	Fuse/Relay Name
11	Red	10A	Battery	Charging system
12	Green	30A	Battery	ABS Control
13	Blue	15A	Battery	Horn
14	Green	30A	Battery	Charging system (trailer tow)
15	—	—	—	Not used
16	Orange	40A	Battery	Body control module (BCM)
17	Black	—	—	Horn relay
18	—	140A 250A*1	Battery	Alternator, BCM, brake control, inverter and engine control transmission control systems
19	—	100A	Battery	Starting, charging and body systems
20	—	80A	Battery	Lighting systems
21	—	60A	Battery	Air conditioner, body and powertrain systems
22	—	80A 100A*1	Battery	Engine control systems
23	—	—	—	Injector 1 relay (VK56VD (5.6L) only)
24	—	—	—	Injector 2 and high pressure fuel pump relay (VK56VD (5.6L) only)
25	Blue	—	—	Daytime light relay - 1
26	Black	—	—	Daytime light relay - 2
27	Black	—	—	Inverter relay
28	—	—	—	Valve event lift motor relay (VK56VD (5.6L) only)
29	Blue	—	—	Tail lamp relay (trailer tow)
30	Blue	—	—	LH turn relay (trailer tow)
31	Brown	—	—	Ignition relay (trailer tow)
32	Blue	—	—	RH turn relay (trailer tow)
33	Blue	—	—	Stop lamp relay
34	Brown	—	—	Back-up lamp relay
35	Yellow	60A	Battery	Inverter system

*1 (VK56VD (5.6L) only)

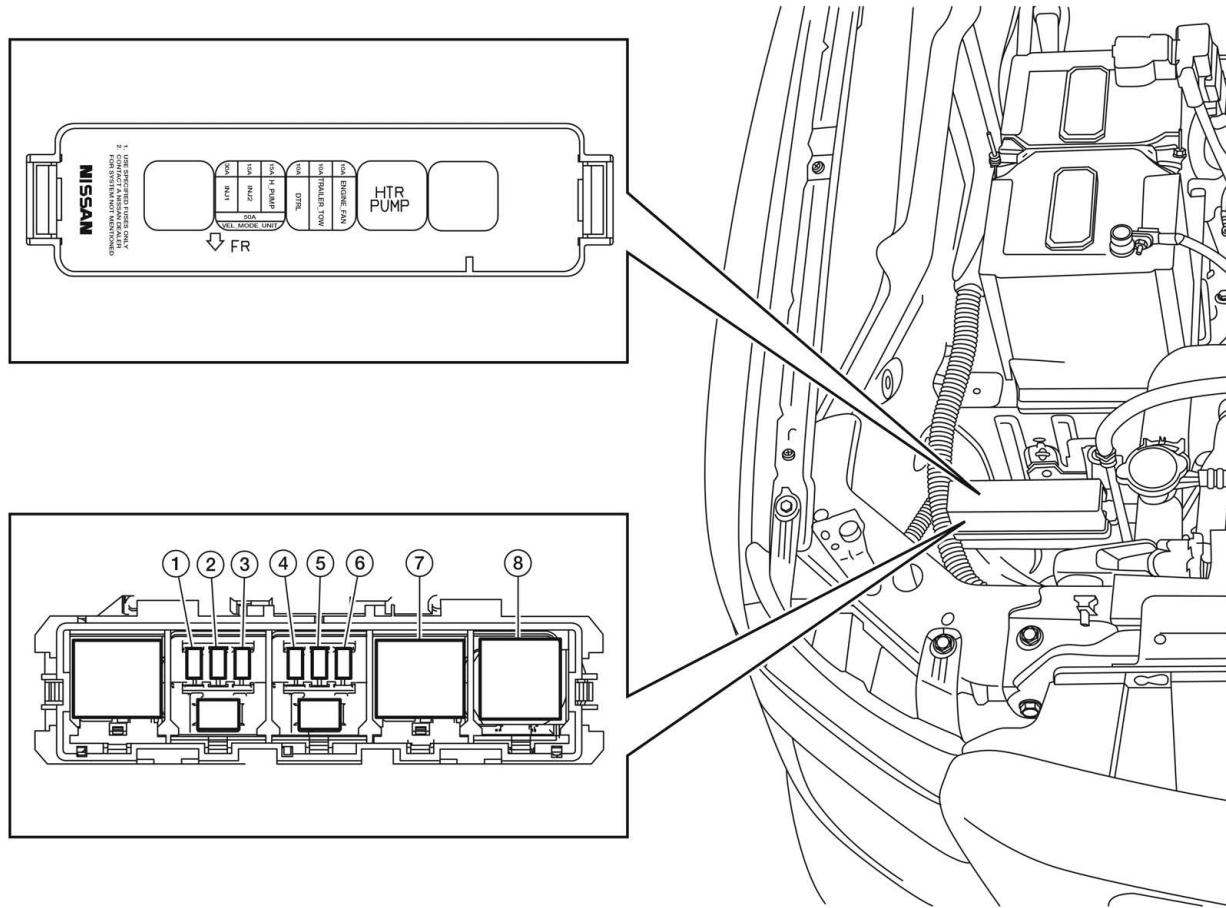

AAZIA0887ZZ

Item	Fuse/Relay Color	Fuse Rating	Power Supply Condition	Fuse/Relay Name
1	Green	30A	B+	Injector 1 fuse
2	Blue	15A	B+	Injector 2 fuse
3	Blue	15A	B+	Heater pump fuse (VK56VD 5.6L engine)
4	Red	10A	B+	Daytime running lamps fuse
5	Red	10A	B+	Trailer tow fuse
6	Red	10A	B+	Radiator fan fuse
7	—	—	—	Not used
8	—	—	—	Not used

Fuses and Relays – Interior

1. USE SPECIFIED FUSE ONLY
2. CONTACT A DEALER FOR SYSTEMS NOT LISTED

①	IGN 10A	ELEC PARTS	IGN 10A	WASHER	⑭
②	IGN 10A	AIRBAG			⑮
③	IGN				⑯
④	IGN		ACC		⑰
⑤	IGN		ACC 20A	FRONT POWER OUTLET	⑱
⑥	BAT 15A	AUDIO/ TELEMATICS	ACC		⑲
⑦	BAT 15A	FRONT BLOWER RELAY	ACC 10A	MIRROR	⑳
⑧	BAT 10A	ELEC PARTS		FUSE PULLER	
⑨	BAT				㉑
⑩	BAT 10A	STOP LAMP	ACC 10A	AUDIO/ TELEMATICS	㉒
⑪	BAT 10A	INTERIOR LAMPS	IGN 15A	FRONT BLOWER	㉓
⑫	20A	SPARE	IGN		㉔
⑬	10A	SPARE	15A	SPARE	㉕

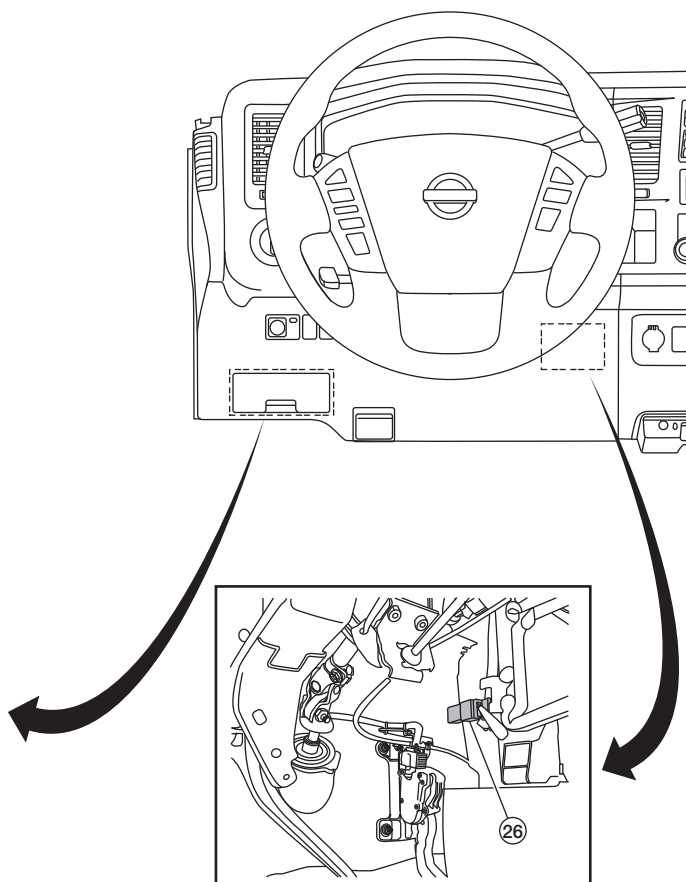

AAZIA0472ZZ

Item	Fuse/Relay Color	Fuse Rating	Power Supply Condition	Fuse/Relay Name
1	Red	10A	Ignition	ABS controller, Body control module (BCM), buzzers and chimes, data link connector (DLC), engine control module (ECM), instrument cluster, inverter system, sonar control unit
2	Red	10A	Ignition	Air bag system
3	—	—	—	Not used
4	—	—	—	Not used
5	—	—	—	Not used
6	Blue	15A	B+	Bluetooth® control unit, radio
7	Blue	15A	B+	Front blower relay
8	Red	10A	B+	Air conditioner control, DLC, instrument cluster
9	—	—	—	Not used
10	Red	10A	B+	Stop lamp system

FUSE AND RELAY INFORMATION

[ELECTRICAL]

Item	Fuse/ Relay Color	Fuse Rating	Power Supply Condition	Fuse/Relay Name
11	Red	10A	B+	BCM, interior lighting, vehicle security system
12	Yellow	20A	—	Spare
13	Red	10A	—	Spare
14	Red	10A	Ignition	Wiper and washer system switch
15	—	—	—	Not used
16	—	—	—	Not used
17	—	—	—	Not used
18	Yellow	20A	Accessory, Ignition	Front 12V power socket
19	—	—	—	Not used
20	Red	10A	Accessory, Ignition	Power door mirrors
21	—	—	—	Not used
22	Red	10A	Accessory	BCM, Bluetooth [®] control unit, instrument cluster, radio
23	Blue	15A	Ignition	Air conditioner control, front blower motor
24	—	—	—	Not used
25	Blue	15A	—	Spare
26	Blue	—	—	Automatic transmission control module relay

GROUNDS



CAUTION:

- Do not ground accessories directly to the battery negative terminal on any Nissan vehicle. Doing so may interfere with the power generation voltage variable control system and cause poor or inoperative battery charging.
- Install electrical accessories using suitable body ground connections or ground to the engine block area. Refer to **BATTERY VOLTAGE CONTROL SYSTEM (pg. 229)** in this section.

It is the responsibility of the vehicle upfitter to install any grounds necessary for equipment from aftermarket or second stage equipment manufacturers. Nissan factory grounds should not be altered.

Permissible Ground Location

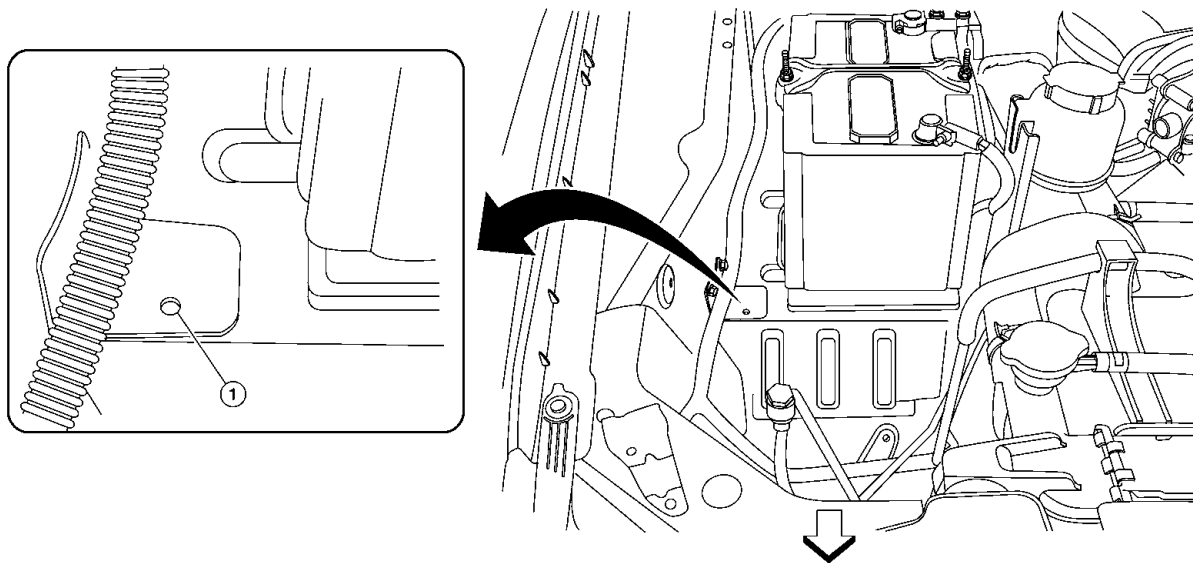

AAZIA0321GB

↙: Front of vehicle

1. Permissible ground location

Use a self-tapping screw with dielectric grease to fasten additional underhood accessory grounds.

BATTERY VOLTAGE CONTROL SYSTEM**CAUTION:**

- **Do not ground accessories directly to the battery negative terminal on any Nissan vehicle. Doing so may interfere with the power generation voltage variable control system and cause poor or inoperative battery charging.**
- **Install electrical accessories using suitable body ground connections or ground to the engine block area.**
- **Use electrical accessories with the engine running to avoid discharging the vehicle battery.**

Adding electrical devices puts more load on the electrical system and the battery. The engine control module (ECM) monitors battery voltage. If battery voltage drops below 12 volts, engine RPM is increased up to 800 RPM (maximum for Park, Neutral and Drive when the engine is at normal operating temperature). RPM will decrease as battery voltage increases. Engine RPM changes are gradually ramped up and down by ECM control.

For battery specifications, refer to [BATTERY \(pg. 353\)](#) in the Specifications section.

BATTERY VOLTAGE CONNECTION

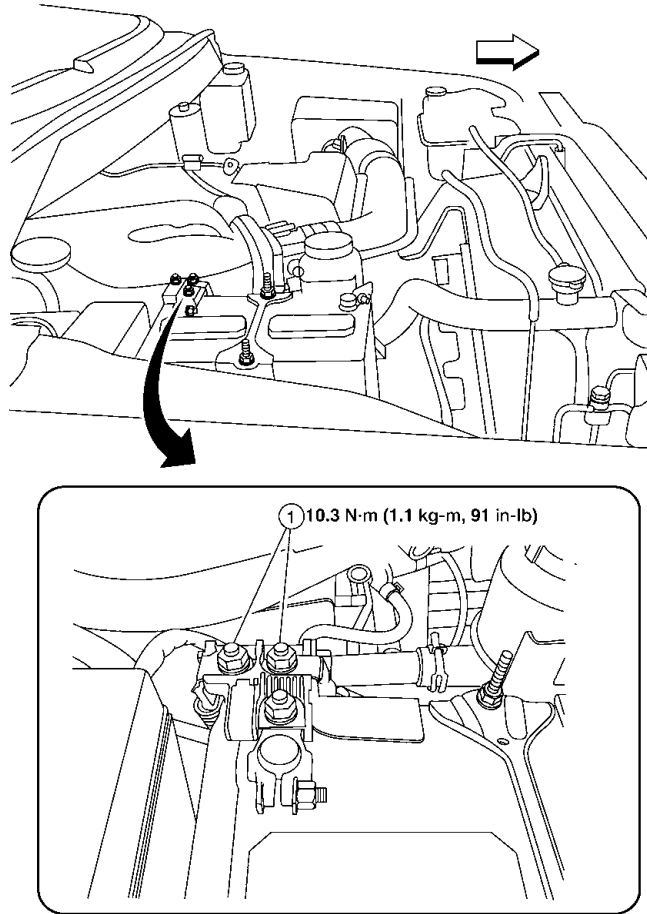

AAZIA0320GB

↔: Front of vehicle

1. Battery fusible link terminal nuts

CUSTOMER PRE-WIRING ACCESS

Upfitter Pre-Wiring

Connector No.	E56
Connector Name	UPFITTER 1
Connector Color	GRAY



Terminal No.	Color of Wire	Signal Name	Wire Gauge	Maximum Load
1	Red	Auxiliary Equipment Power1	10	50A
2	Black	Auxiliary Equipment Power2 (or Ground)	10	50A

Connector No.	E58
Connector Name	UPFITTER 3
Connector Color	GRAY



Terminal No.	Color of Wire	Signal Name	Wire Gauge	Maximum Load
1	White	Auxiliary Circuit 1	20	10A
2	Blue	Auxiliary Circuit 2	20	10A
3	Yellow	Auxiliary Circuit 3	20	10A
4	Green	Auxiliary Circuit 4	20	10A

PREWIRING - UPFITTER

Location - rear left side of engine compartment.

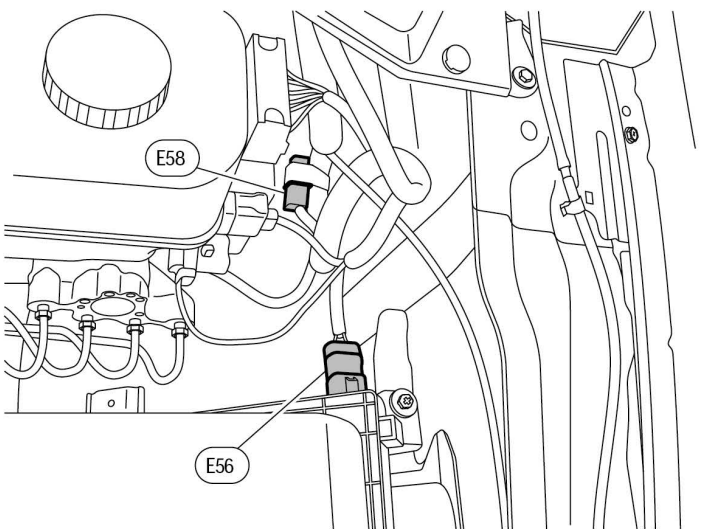

This is pass-through wiring that is pre-installed into the vehicle wiring harness to allow easy connection of auxiliary equipment wiring.

TGAAZIA0028GB

PREWIRING - UPFITTER

Location - lower left side behind kick panel. Remove kick panel for access.

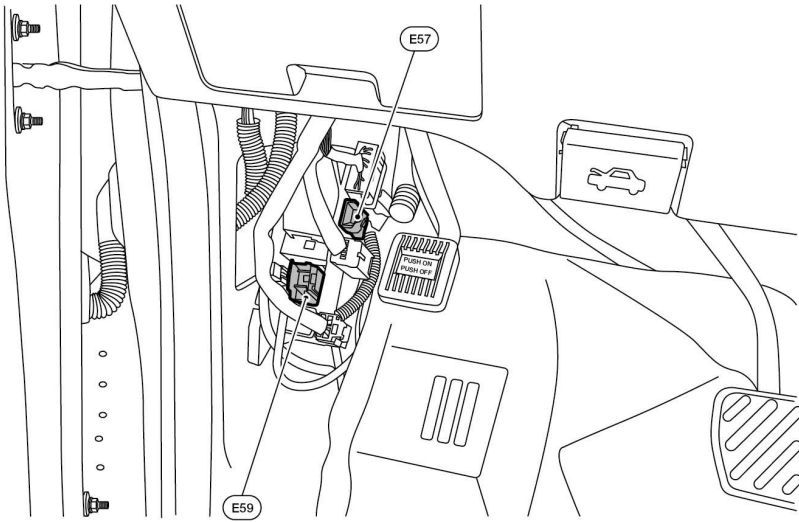

This is pass-through wiring that is pre-installed into the vehicle wiring harness to allow easy connection of auxiliary equipment wiring.

TCAAZIA0029GB

Connector No.	E57
Connector Name	UPFITTER 2
Connector Color	BLACK



Terminal No.	Color of Wire	Signal Name	Wire Gauge	Maximum Load
1	Red	Auxiliary Equipment Power1	10	50A
2	Black	Auxiliary Equipment Power2 (or Ground)	10	50A

Connector No.	E59
Connector Name	UPFITTER 4
Connector Color	WHITE (UP TO 2016), BROWN (FROM 2017)



Terminal No.	Color of Wire	Signal Name	Wire Gauge	Maximum Load
1	White	Auxiliary Circuit 1	20	10A
2	Blue	Auxiliary Circuit 2	20	10A
3	Yellow	Auxiliary Circuit 3	20	10A
4	Green	Auxiliary Circuit 4	20	10A

Telematics Connector Terminal Layout

Connector No.	M7
Connector Name	PRE-WIRING FOR TELEMATICS CONTROL MODULE
Connector Color	WHITE

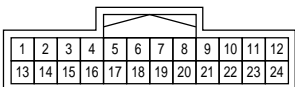

Terminal No.	Color of Wire	Signal Name	Wire Gauge	Maximum Load
3	White	PARK SIGNAL	20	Less than 77 mA
4	Blue	DOMELAMP (GND)	20	2.5 A
5	Red	IGN	20	500 mA
6	White	DOOR AJAR ALL	20	1.5 A (with step lamps) 2 A (without step lamps)
8	Yellow	DOOR UNLOCK	20	–
9	Pink	AIRBAG WARNING	20	Do Not Use
10	Orange	ACC	22	5 A
11	White	COLLISION NOTIFY	20	Less than 10 mA
12	Blue	CAN-H	20	–
16	Green	PARKING BRAKE	20	2 A
17	Orange	REVERSE SIGNAL	20	5 A
18	Purple	ILL+	20	6 A
21	Sky Blue	DOOR LOCK	20	–
22	Black	GND	22	10 A
23	Yellow	B+	22	5.5 A
24	Pink	CAN-L	20	–

UPFITTER PRE-WIRING (TELEMATICS)

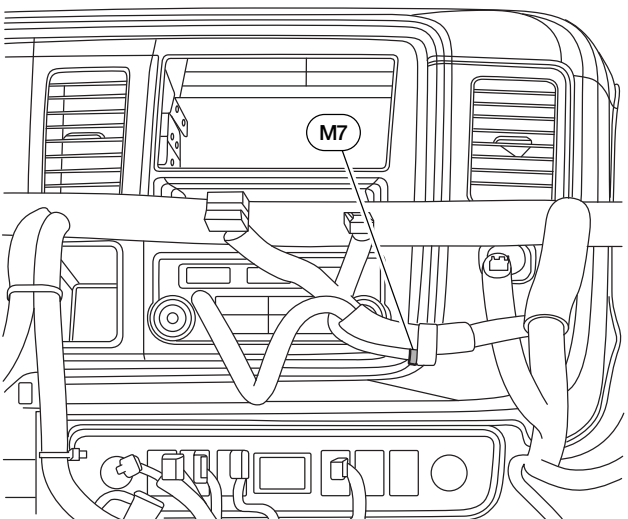

AAZIA0379CB

TGAAZ1A0021GB

REAR SPEAKER WIRING

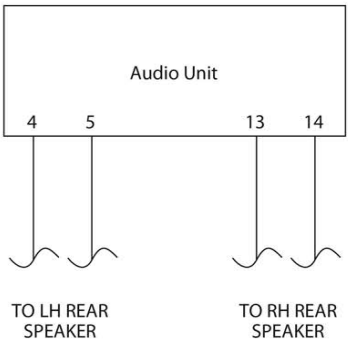

Connector No.	M42 (2012-2017 model years)	M50	M44
Connector Name	AUDIO UNIT (WITH BASE AUDIO SYSTEM)	AUDIO UNIT (WITH MID AUDIO SYSTEM OR DISPLAY AUDIO SYSTEM)	AV CONTROL UNIT (WITH PREMIUM AUDIO SYSTEM OR DISPLAY AUDIO SYSTEM)
Connector Color	WHITE	WHITE	WHITE

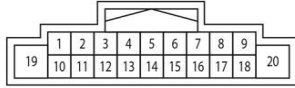

Terminal No.	Signal Name
4	REAR SP LH +
5	REAR SP LH -
13	REAR SP RH +
14	REAR SP RH -

CAUTION: Only use speakers rated at 2 ohms impedance to avoid damaging the audio unit. Connector pins and wiring must be inserted into the connector cavities indicated. Use pin terminals supplied with Genuine Nissan Harness Repair Kit (J-48817).

HARNESS LAYOUT

Harness Outline (High Roof)

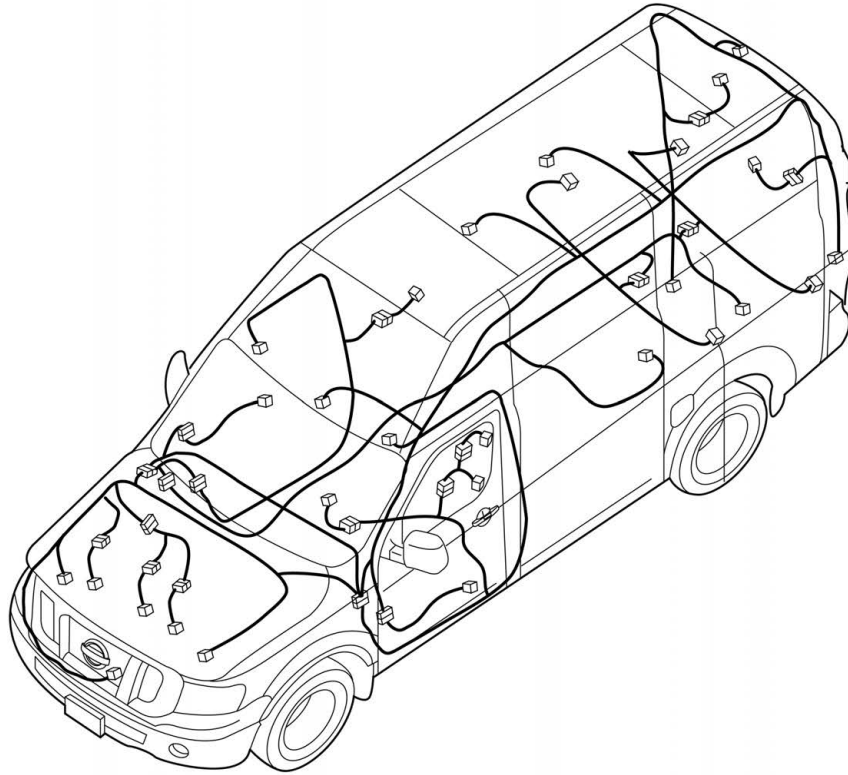

ABMIA2819GB

Harness Outline (Standard Roof)

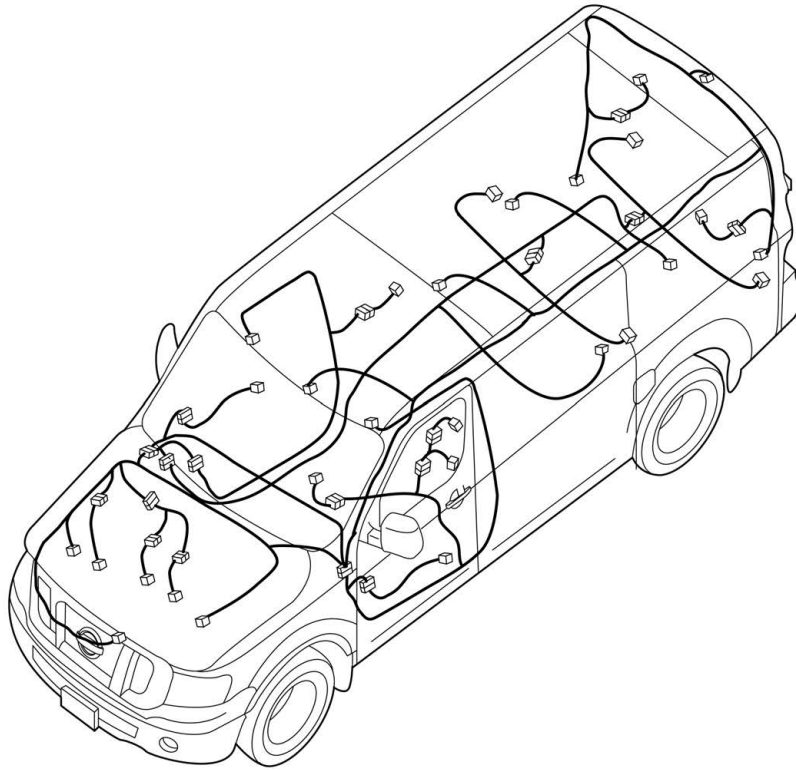

ABMIA2820GB

Main Harness

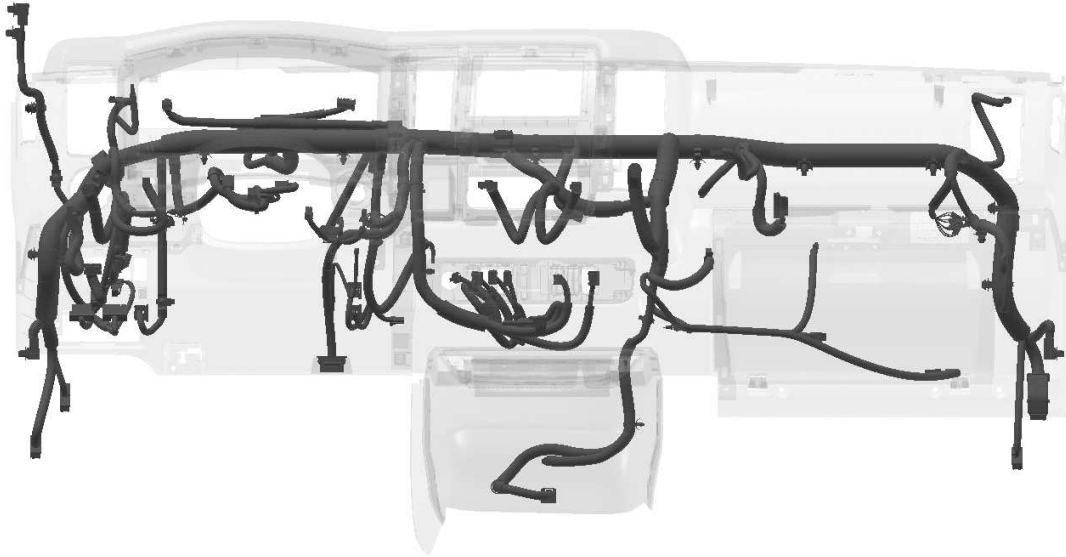

AAZIA0102ZZ

Chassis Harness (Except VK56VD 5.6L) (2012 - 2016 Model Years)

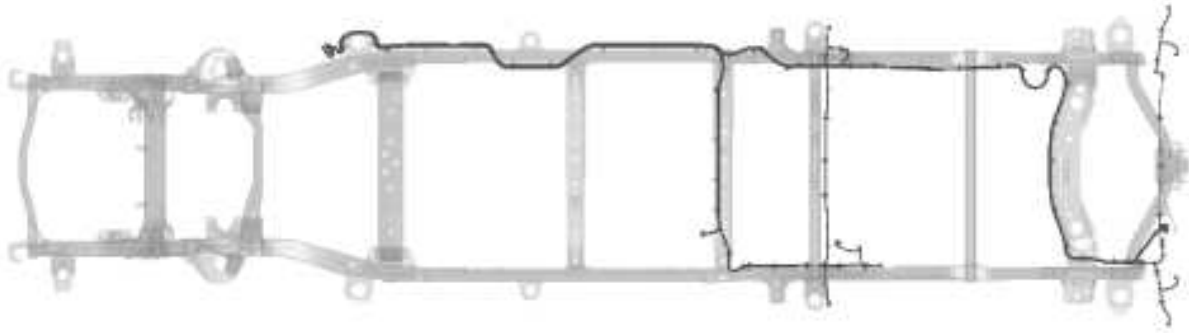

AAZIA0097ZZ

Chassis Harness (VK56VD 5.6L) (Starting in 2017)

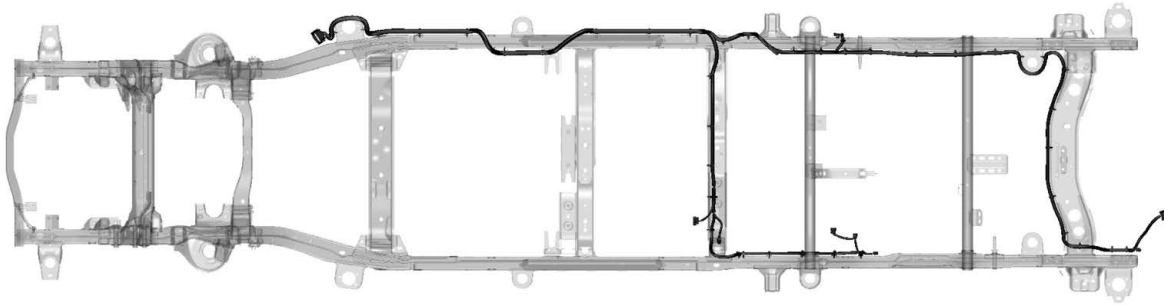

AAZIA0889ZZ

Engine Room Harness (Except VK56VD 5.6L) (2012 - 2017 Model Year)



AAZIA0098ZZ

Engine Room Harness (VK56VD 5.6L) (Starting in 2017)

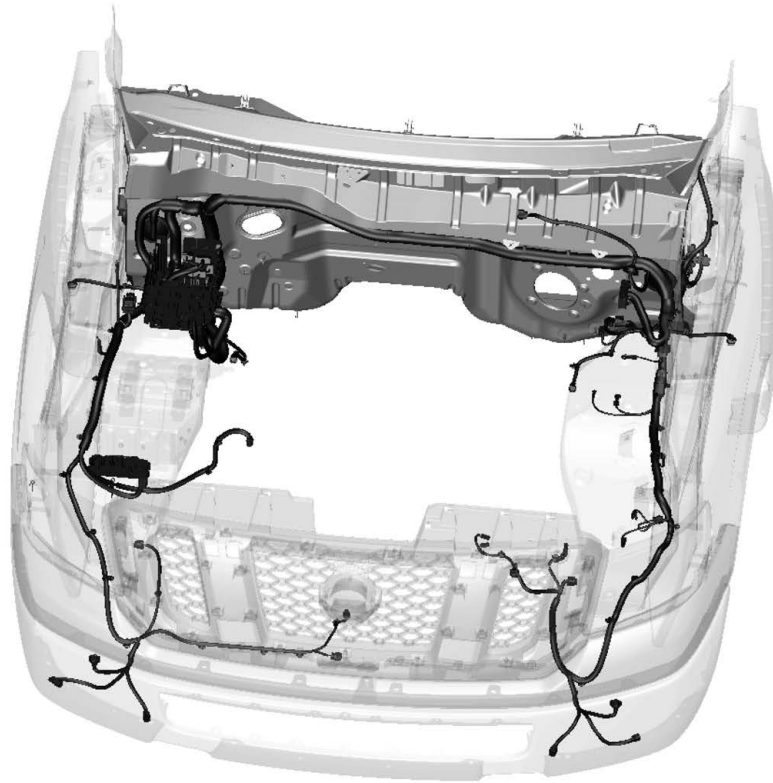

AAZIA0888ZZ

Engine Room Harness (Passenger Compartment)

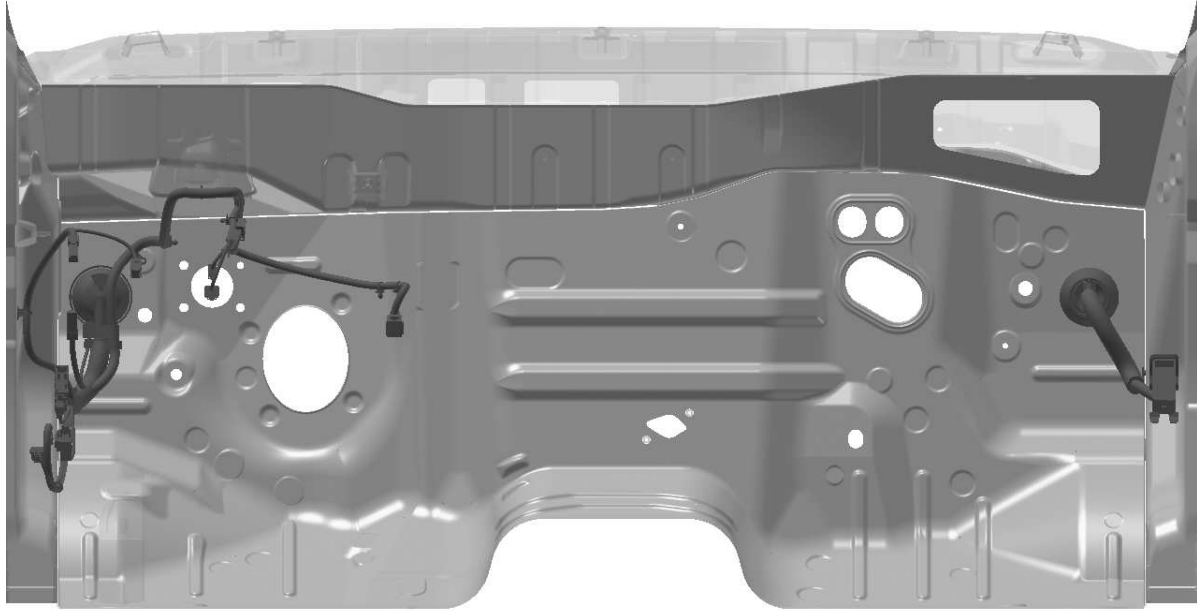

AAZIA0099ZZ

Engine Control Harness (VQ40DE 4.0L)

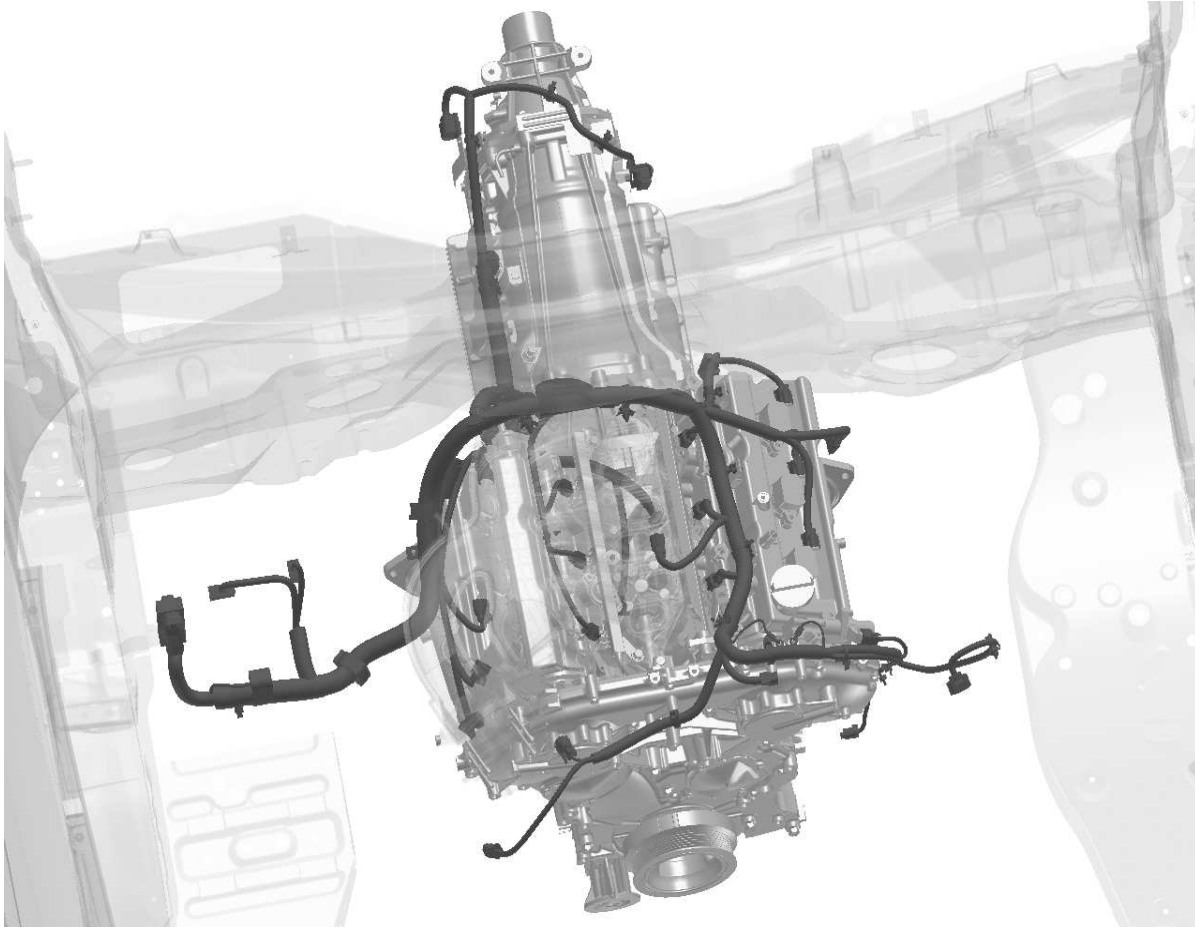

AAZIA0108ZZ

Engine Control Harness (VK56DE 5.6L) (2012–2016 Model Years)

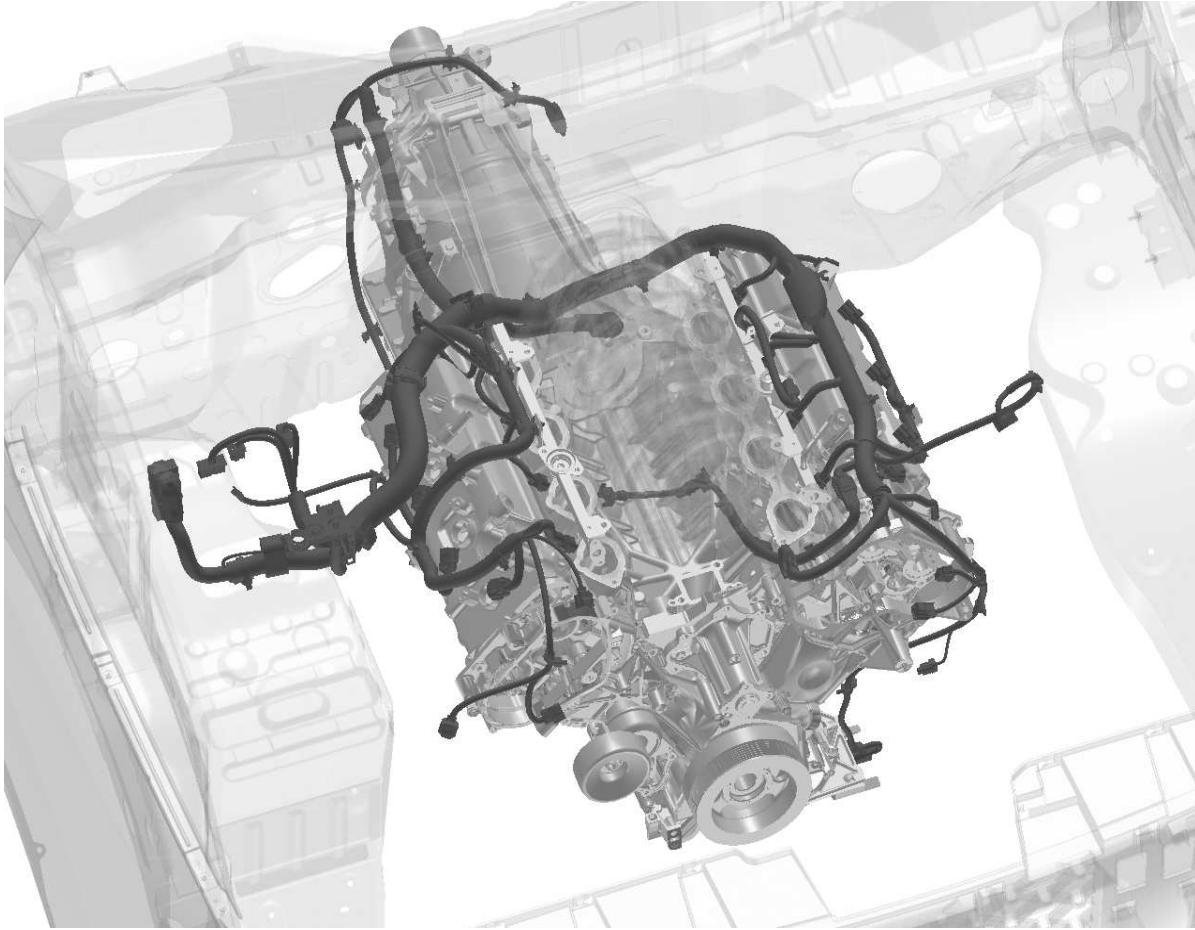

AAZIA0107ZZ

Engine Control Harness (VK56VD 5.6L) (Starting 2017 Model Year)

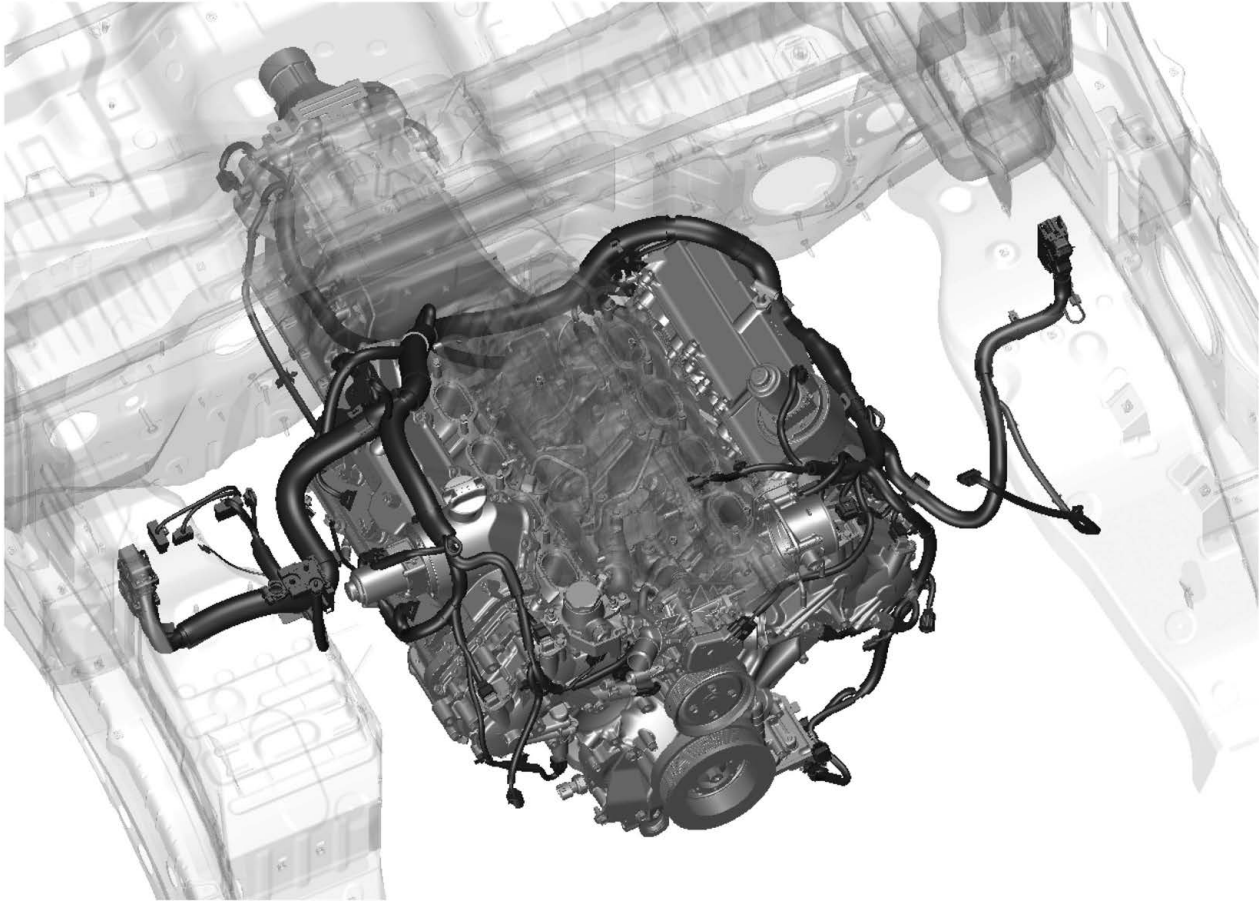

AAZIA0862ZZ

Body Harness (High Roof)

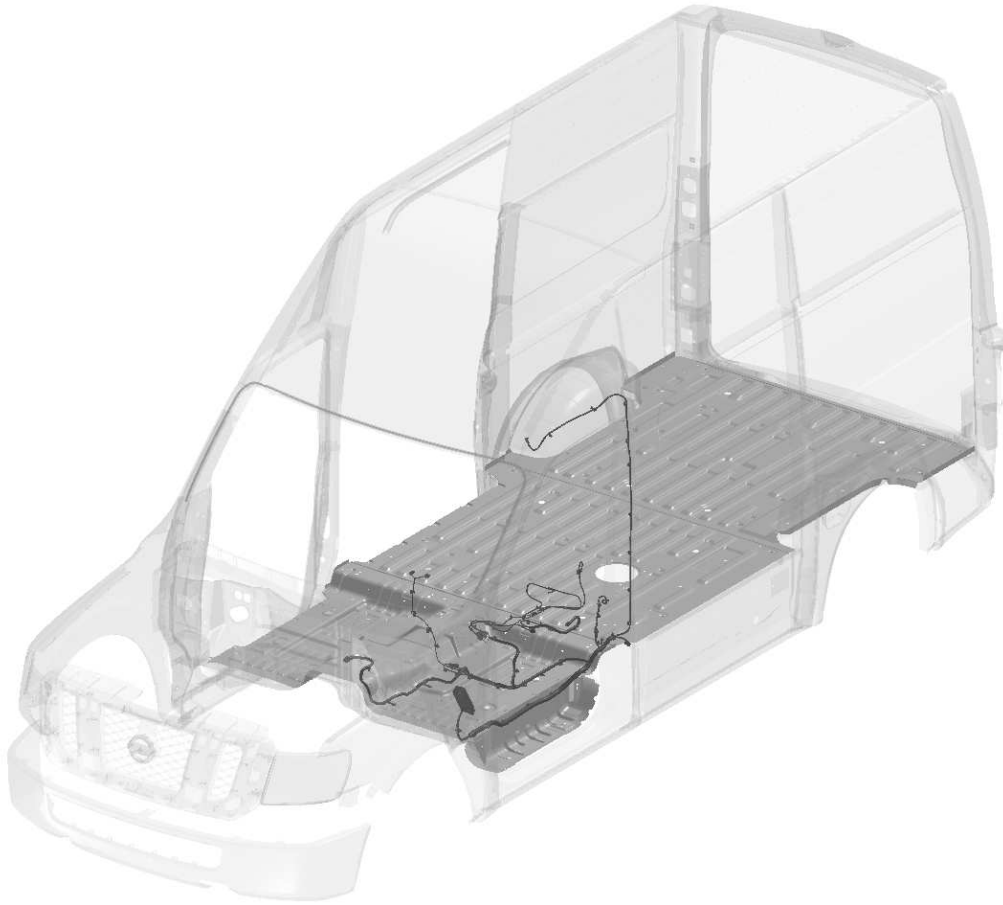

AAZIA0093ZZ

Body Harness (Standard Roof)

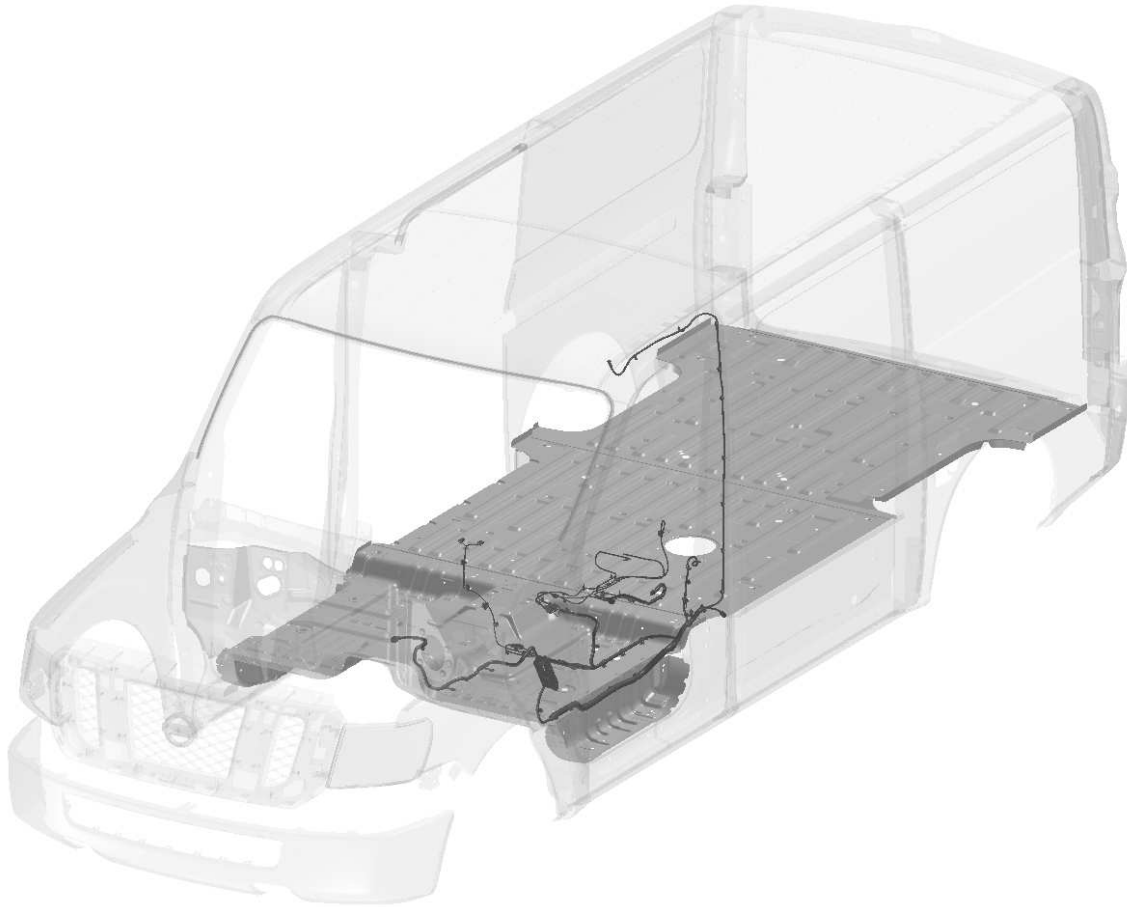

AAZIA0094ZZ

Body No. 2 Harness (High Roof)

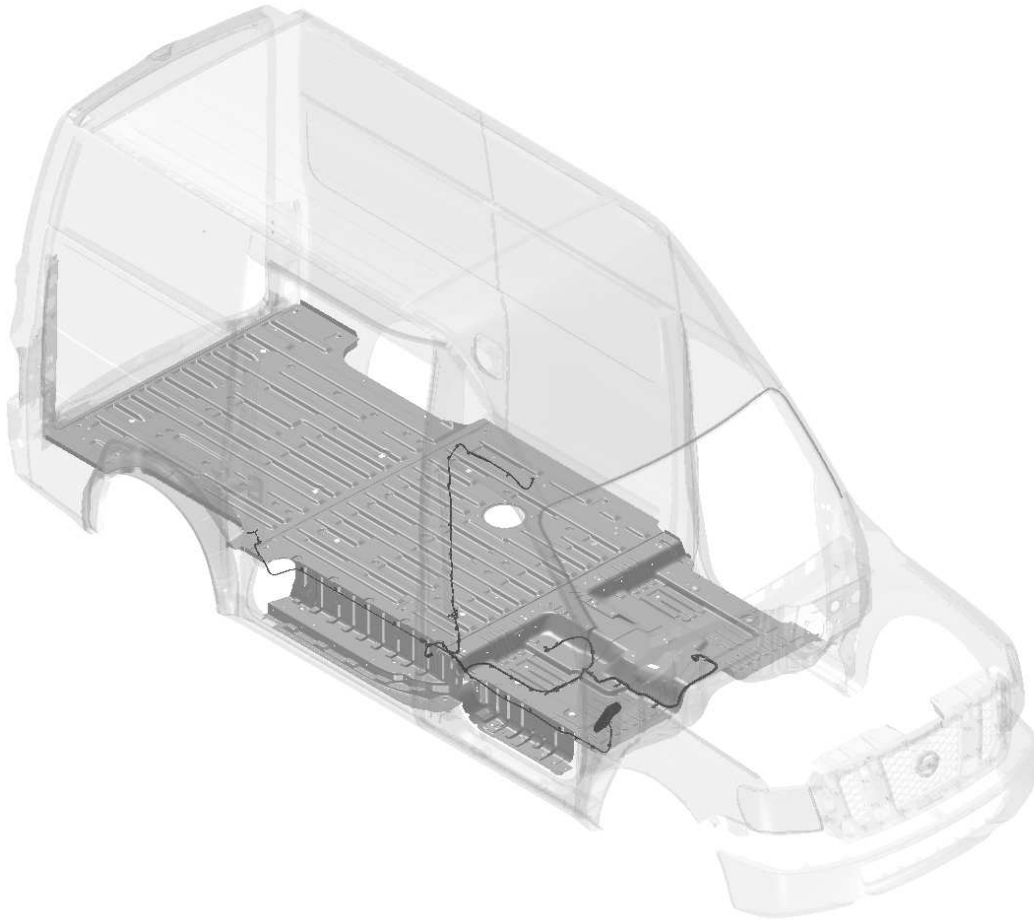

AAZIA0095ZZ

Body No. 2 Harness (Standard Roof)

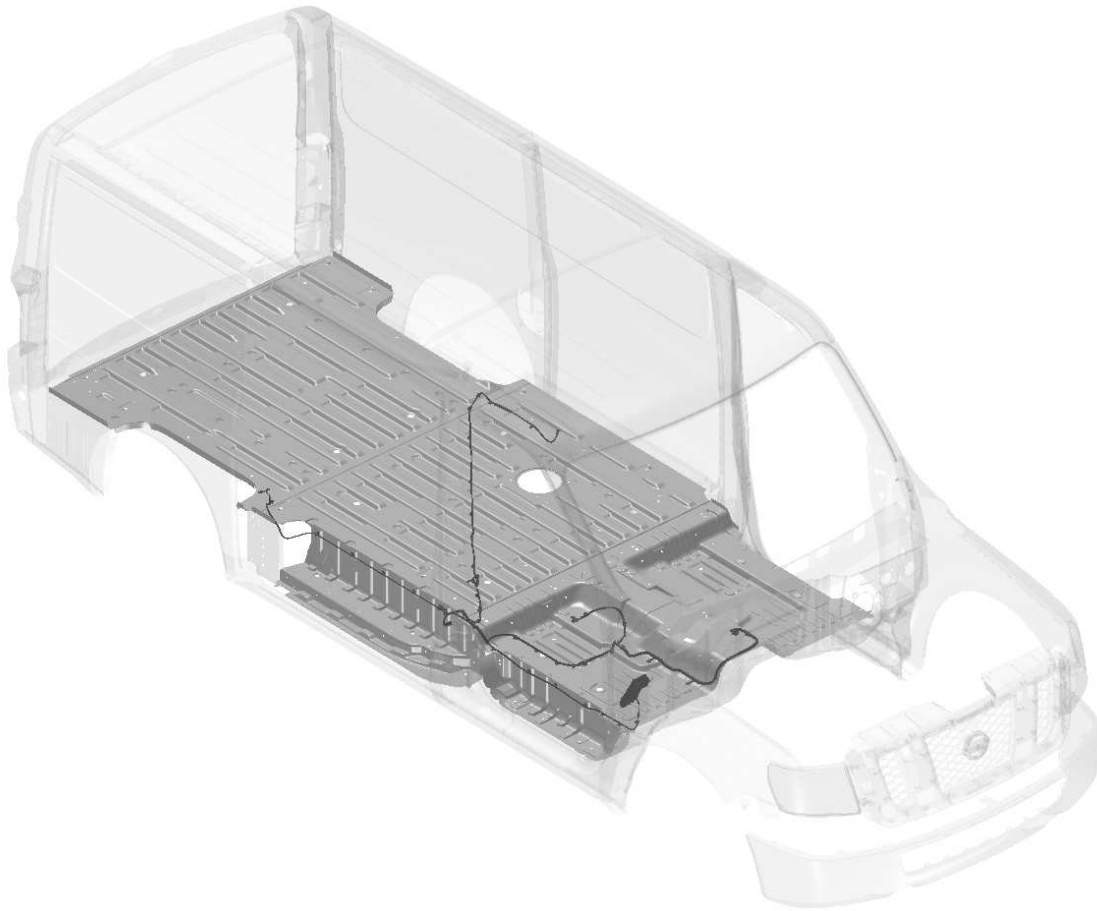

AAZIA0096ZZ

Room Lamp Harness (High Roof)

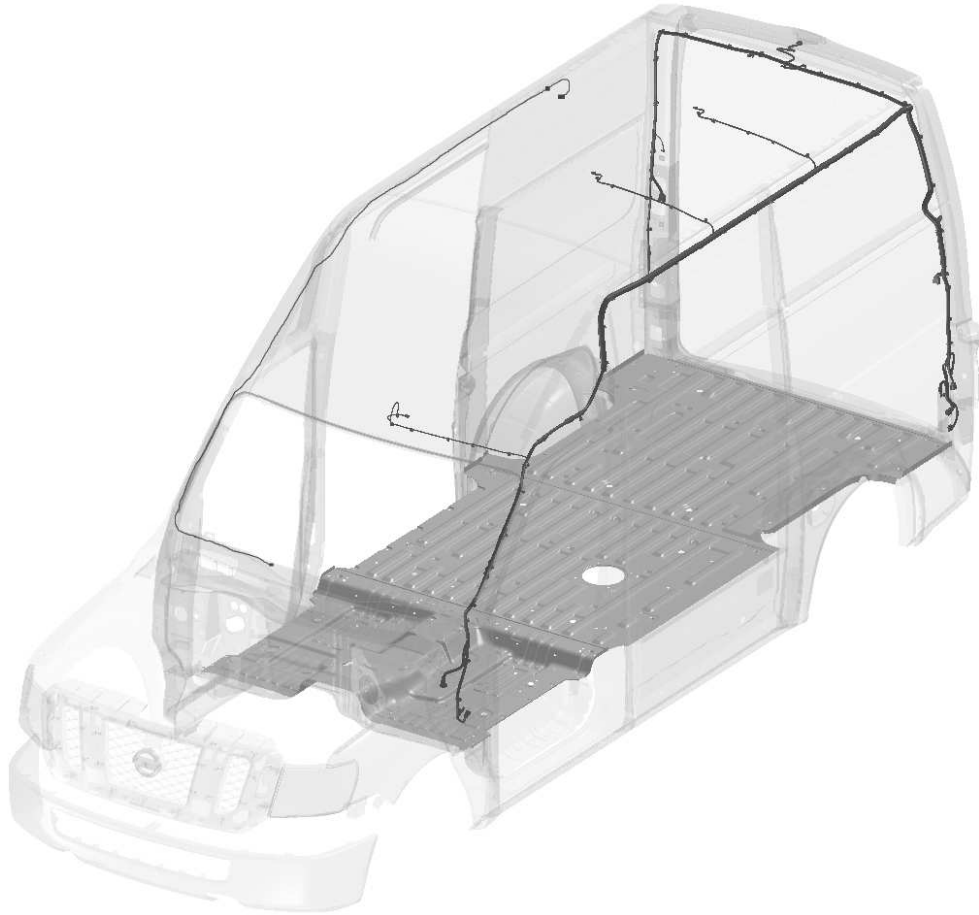

AAZIA0103ZZ

Room Lamp Harness (Standard Roof)

NOTE:

Room lamp harness may be taped back in S-grade NV1500.

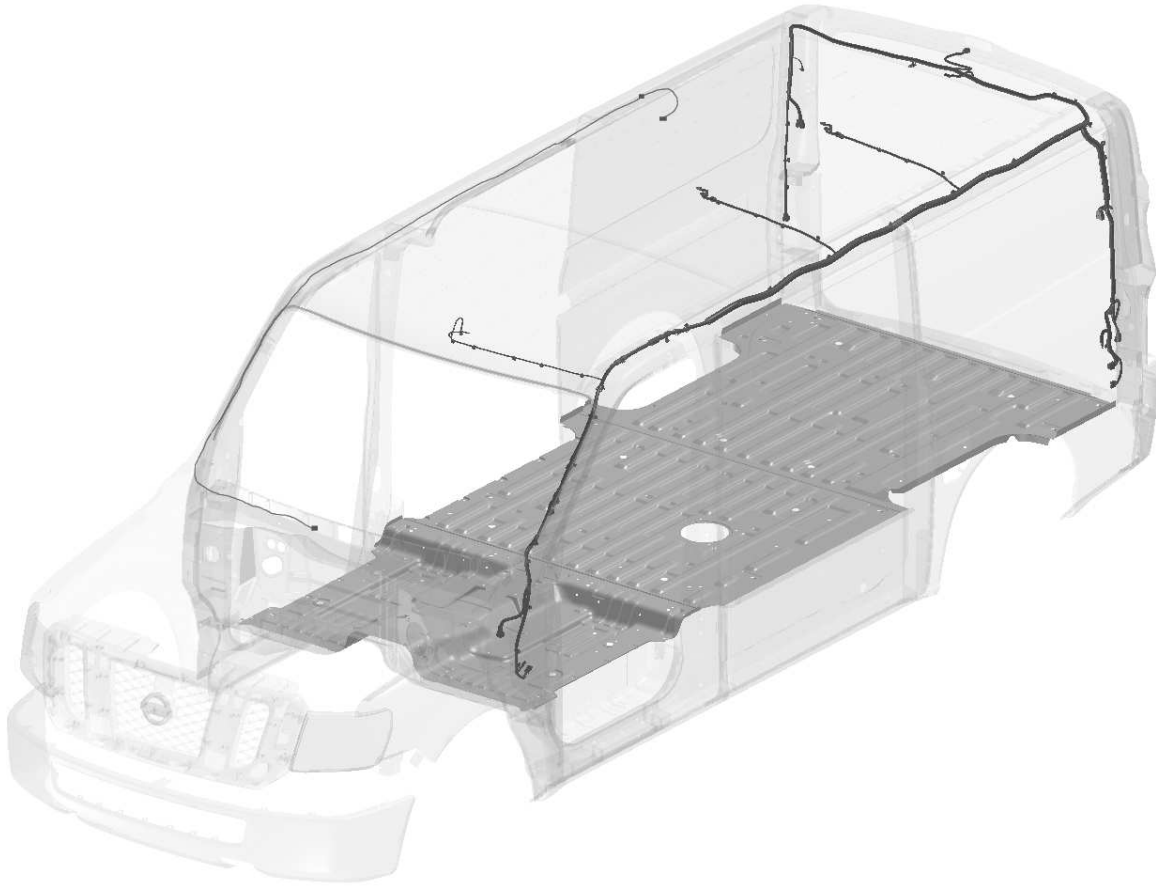

AAZIA0104ZZ

Front Door LH Harness

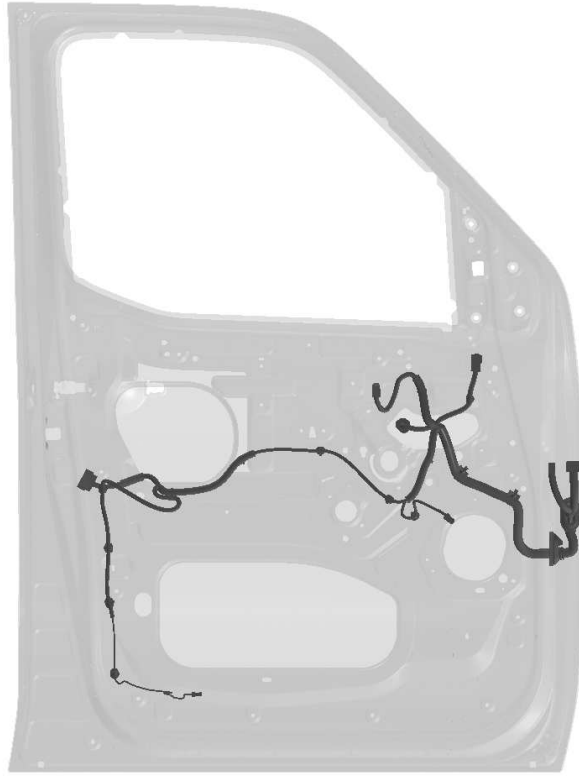

AAZIA0100ZZ

Front Door RH Harness

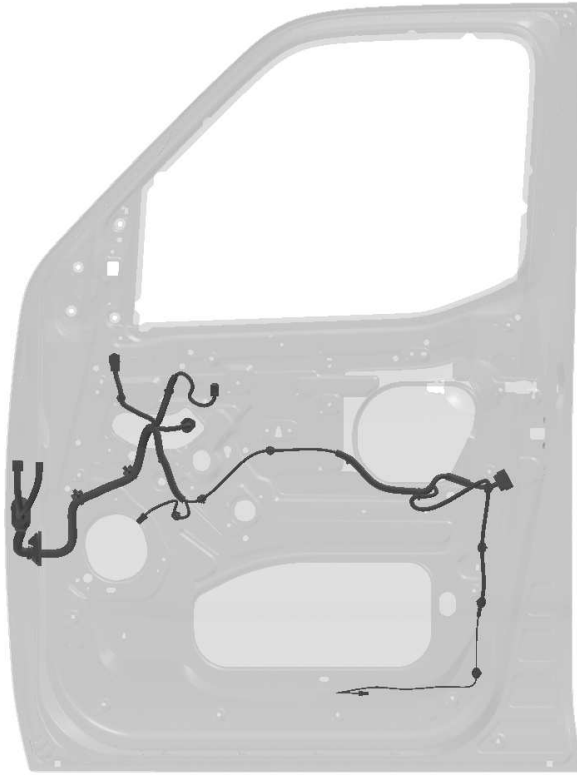

AAZIA0101ZZ

Sliding Door Harness (High Roof)



AAZIA0105ZZ

Sliding Door Harness (Standard Roof)

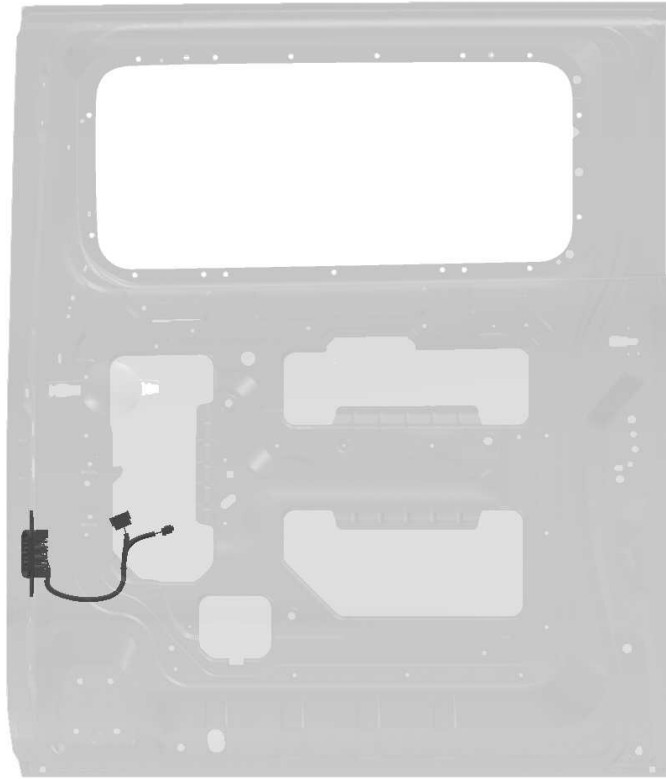

AAZIA0106ZZ

Back Door LH Harness (High Roof)



AAZIA0089ZZ

Back Door LH Harness (Standard Roof)

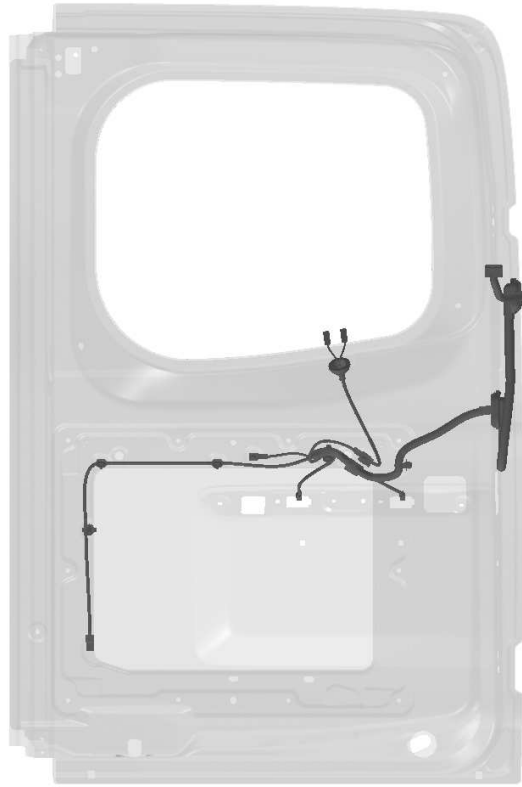

AAZIA0090ZZ

Back Door RH Harness (High Roof)



AAZIA0091ZZ

Back Door RH Harness (Standard Roof)

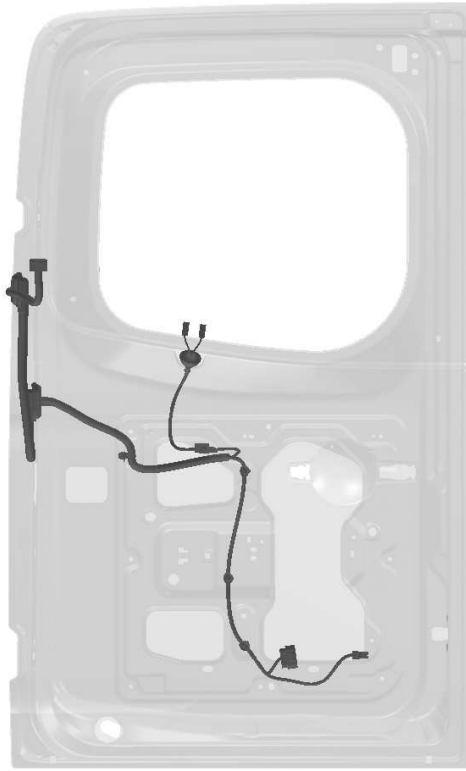

AAZIA0092ZZ

BULBS

Exterior Lamps – 2012-2018 Model Years

Item		Wattage (W)*	Bulb No.*
Front combination lamp	Turn signal/parking lamp	27/7	3157AK
	Side marker	3.8	194K
	Headlamp low/high	55/65	H13
Rear combination lamp	Stop/tail lamp	27/8	3157KXRD
	Turn signal lamp	27	3156AK
	Back-up lamp	18	921
High-mounted stop lamp		18	921
License plate lamp		5	W5W

* Always check with an authorized NISSAN dealer for the latest parts information.

Exterior Lamps – 2019 Model Year

Item		Wattage (W)*	Bulb No.*
Front combination lamp	Turn signal/parking lamp	27/7	3157AK
	Side marker	3.8	194K
	Headlamp low/high	55/60	H13
Rear combination lamp	Stop/tail lamp	27/8	3157KXRD
	Turn signal lamp	27	3156AK
	Back-up lamp	18	921
High-mounted stop lamp		18	921
License plate lamp		5	W5W

* Always check with an authorized NISSAN dealer for the latest parts information.

Exterior Lamps – 2020-2021 model years

Item		Wattage (W)*	Bulb No.*
Front combination lamp	Turn signal/parking lamp	27/7	3157AK
	Side marker	3.8	194
	Headlamp low/high	55/60	H13
Rear combination lamp	Stop/tail lamp	27/8	3157KX
	Turn signal lamp	27	3156AK
	Back-up lamp	18	921
High-mounted stop lamp		18	921
License plate lamp		5	W5W

* Always check with an authorized NISSAN dealer for the latest parts information.

Interior Lamp/Illumination

Item	Wattage (W)*	Bulb No.*
Front room/map lamp	8	—
Cargo lamp	10	—

* Always check with an authorized NISSAN dealer for the latest parts information.

HEADLAMP AIMING

Inspection

NOTE:

The aftermarket equipment manufacturer, second stage manufacturer, and upfitter are responsible for maintaining or restoring the headlamp adjustment after modifications to the vehicle are complete. The upfitter is responsible for maintaining compliance with the Federal or Canadian Motor Vehicle Safety Standards.

Preparation Before Adjusting

Before performing aiming adjustment, check the following:

- Modifications are complete and the vehicle is unladen.
- Adjust the tire pressure to the specification.
- Place the vehicle on a level surface.
- Fill vehicle with fuel, engine coolant, and engine oil.
- Remove cargo to maintain an unloaded vehicle condition.
- Confirm the spare tire, jack, and tools are present and properly stowed.
- Place a driver or equivalent weight of 68.5 kg (150 lbs) on the driver seat.
- By hand, bounce the front and rear of the vehicle to settle the suspension and eliminate any static load.
- Place the front tires in the straight ahead position.
- Carefully wipe off any dirt from the headlamp lens.



CAUTION:

To avoid damage to the headlamp lens, never use organic solvent (thinner, gasoline, etc.).

NOTE:

- For headlamp aiming details, refer to the regulations in your own area.
- Perform headlamp aiming if the vehicle front body has been repaired and/or the front combination lamp has been removed or replaced.
- By regulation, no means for horizontal adjustment is provided. Horizontal aim will only be serviced by combination lamp replacement.

Aiming Adjustment Screw

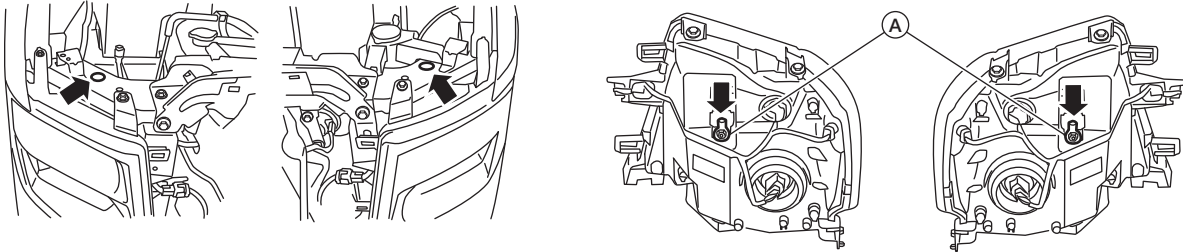

ALLIA0977ZZ

A. Headlamp (UP/DOWN) adjustment screw

- Rotate the headlamp (UP/DOWN) adjustment screw to raise or lower the headlamp vertical beam pattern, using a suitable tool.

A: Rotate counterclockwise to lower beam pattern (DOWN).

B: Rotate clockwise to raise beam pattern (UP).



CAUTION:

Do not rotate headlamp (UP/DOWN) adjustment screw beyond a torque of 1.67 N-m (17 kg-cm, 14.8 in-lb), or damage may occur.

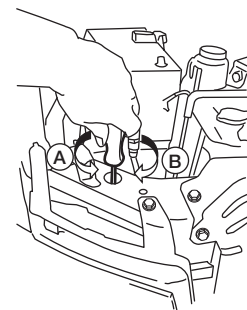

ALLIA0976ZZ

Vertical Aiming Adjustment Procedure

NOTE:

Horizontal adjustment is not possible. If horizontal adjustment is off, then the headlamp assembly from that side should be replaced.

Aiming Chart

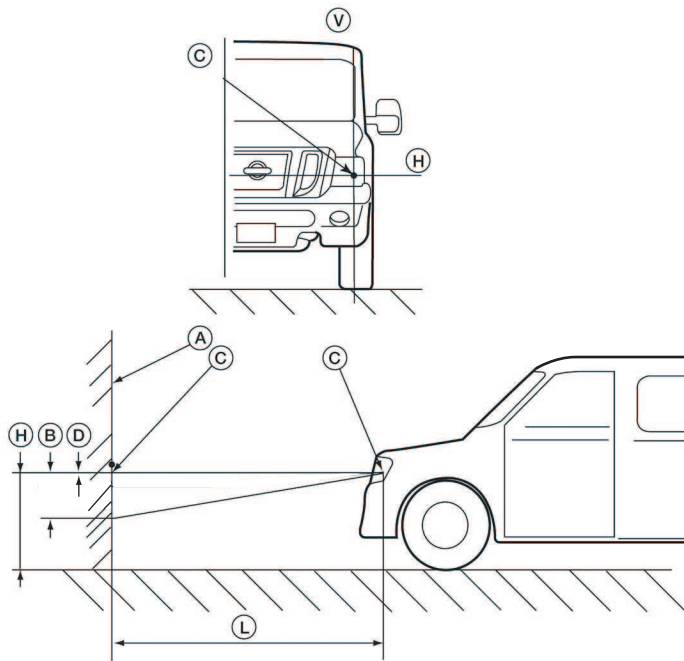

AAZIA0272GB

- | | | |
|--|---|---|
| A. Screen surface | B. Lowest cutoff line height
53.2 mm (2.09 in) (up to 2016)
66.5 mm (2.62 in) (from 2017) | C. Center of headlamp bulb
(H-V point) |
| D. Highest cutoff line height
0.0 mm (0.0 in) | H. Horizontal center line of
headlamp | L. 7.62 m (25 ft) |
| V. Vertical center line of
headlamp | | |

1. Place the screen on the same level and flat surface as the vehicle.

NOTE:

Surface should be free of any debris that would cause a difference in vehicle side-to-side height.

2. Face the front of the vehicle to the screen and measure distance between the headlamp center and the screen surface.
 - Distance between the headlamp center and the screen (L): 7.62 m (25 ft)
3. Block the opposite headlamp from projecting a beam pattern onto the adjustment screen, using a suitable object. Aim each headlamp individually.



CAUTION:

Never cover the lens surface with tape or plastic, etc. The lens is made of resin.

4. Start the engine. Turn the headlamps on.
5. Determine the preferred vertical aim range dimensions, using the aiming chart.
6. Measure the projected beam within the aim evaluation segment on the screen.
7. Adjust the beam pattern of each headlamp until the aim evaluation segment (the area relative to both the highest and lowest cutoff line height) is positioned within the vertical aim range dimensions shown on the aiming chart.

FRONT FOG LAMP AIMING

Aiming Adjustment

NOTE:

Check the following conditions before performing the aiming adjustment.

- Keep all tires inflated to correct pressure.
- Place vehicle on level ground.
- See that vehicle is unloaded (except for full levels of coolant, engine oil and fuel, and spare tire, jack, and tools). Have driver or equivalent weight placed in driver seat.
- When performing adjustment, if necessary, cover the headlamps and opposite fog lamp.

1. Set the distance between the screen and the center of the fog lamp lens as shown.

- (1) Aiming screen or a matte white surface
- (2) 7.62 m (25 ft)
- (3) Ground to center of fog lamp lens
- (4) Ground

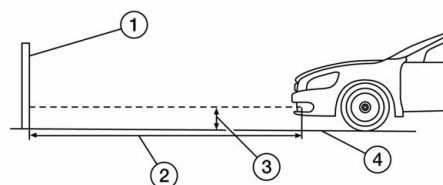

TGAAZIA0032ZZ

2. Turn front fog lamps ON.

3. Using a suitable tool to adjust, rotate screw clockwise to raise pattern and counterclockwise to lower pattern. Adjust front fog lamps using adjusting screw so that the top edge of the high intensity zone is 100 mm (4 in) below the height of the fog lamp centers as shown.

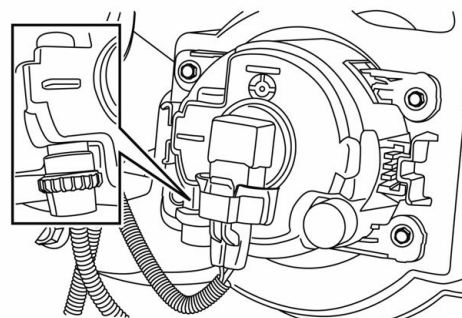

TGAAZIA0033ZZ

NOTE:

Access adjusting screw from underneath front bumper.

- (1) Vertical center line of left fog lamp
- (2) Lamp center above ground
- (3) 100 mm (4 in) (0.76°) below lamp center above ground
- (4) Left fog lamp high intensity area
- (5) Vehicle center axis
- (6) Vertical center line of right fog lamp
- (7) Right fog lamp high intensity area

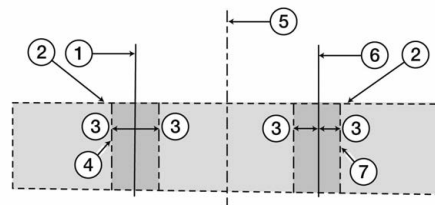

TGAAZIA0034ZZ

ADDING LIGHTS OR DEVICES

Added Lights or Accessories Controlled By Added Switches

This section describes the connection points for added electrical accessories when these accessories are to be controlled by added switches not a part of the Nissan released vehicle. The added switches and wiring must have sufficient electrical capacity for the accessory load and must be protected by appropriate fuses or circuit breakers. Also, added current draw must not cause total loads to exceed capabilities of the base vehicle wiring.

Electrical Wiring – Adding Lights or Electrical Devices



CAUTION:

Improper electrical tie-ins may affect vehicle operation (i.e., engine, transmission). After all electrical or vehicle modifications, confirm that no Diagnostic Trouble Codes (DTCs) are present and all systems operate normally. Road test the vehicle to verify that no DTCs are present. If DTCs are generated, perform the appropriate diagnostic procedures and repairs. Vehicle operation (engine/transmission) may be affected if DTCs are not serviced.

Disconnect the battery negative (ground) cable prior to any vehicle modification. Upon completion of body or equipment installation, all wiring should be checked for proper routing, etc. to preclude electrical shorts upon reconnecting the battery negative cable.

Connect only to the upfitter connections identified in the "customer pre-wiring access" section of this manual. Connecting to any component or wires other than those identified may adversely affect other systems and their operation.

Radio Frequency Interference (RFI)

During modifications to the vehicle, manufacturers, service technicians, owners and users should take the necessary precautions to maintain the RFI integrity of components. (Both the United States and Canada have RFI regulations in effect.) Precautionary procedures and components listed below are examples and do not necessarily represent a complete list.

1. All components required to suppress RFI emissions, which are removed during service, repair, or modification to the vehicle, must be reinstalled in the manner in which they were installed by Nissan.
2. Do not modify or change any RF device in a manner not expressly approved by Nissan.
3. Shields on ignition components must remain installed.
4. Replacement of ignition components which are not OEM is not recommended by Nissan.
5. Electrical grounds on all components must be retained.
6. Metallic components installed on the body or chassis must be grounded to the chassis.
7. Electrical circuits added to the vehicle should not be installed near the ignition components.
8. Only "static conductive" accessory drive belts should be used.
9. Drive belts should be of the OEM type or equivalent that will not build up a static electrical charge.
10. Additional measures may be needed to adequately suppress RFI emissions.

REGULATIONS FOR ADDING COMMUNICATION EQUIPMENT**FCC Regulations**

The FCC rules and regulations are compiled in Title 47 of the Code of Federal Regulations (CFR). They are initially published in the Federal Register. After October 1 of each year, the GPO compiles all the changes, additions, and deletions to the FCC rules and publishes an updated CFR. Refer to the FCC website for the most up-to-date information. The rules are provided in text version and in portable document format (PDF) and can be viewed using the Adobe Acrobat Reader. The FCC does not maintain a database of its rules nor does it print or stock copies of the rules and regulations. To order a copy of Title 47 of the Code of Federal Regulations visit:

www.fcc.gov/encyclopedia/rules-regulations-title-47

FCC Notice:**For USA:**

These devices must comply with Part 15 of the FCC Rules. Operation is subject to the following two conditions:

1. The device may not cause harmful interference.
2. The device must accept any interference received, including interference that may cause undesired operation.

NOTE:

Changes or modifications not expressly approved by the party responsible for compliance could void the user's authority to operate the equipment.

For Canada:

These devices must comply with RSS-210 of Industry Canada. Operation is subject to the following two conditions:

1. The device may not cause interference.
2. The device must accept any interference, including interference that may cause undesired operation of the device.

INVERTER SYSTEM

Description

AC 120-Volt Power Outlet

The AC 120-volt outlets are for devices up to 400-watt. There are 2 operating modes for the inverter system:

1. High power mode for devices between 150-watt and 400-watt which can only be used when the vehicle is in Park (P) with the engine running.
2. Low power mode for devices less than 150-watt which can be used anytime the ignition is in the ON position.



CAUTION:

Operation of the 120-volt system with the ignition in the ON position and the engine not running (idle) will drain the battery charge. This could lead to a dead battery or no start condition.

Do not exceed maximum capacity or use adapters to connect more than one electrical accessory.

NOTE:

Replacement of the OEM inverter with anything other than a Genuine NISSAN specified part is not authorized.

Component Parts Location

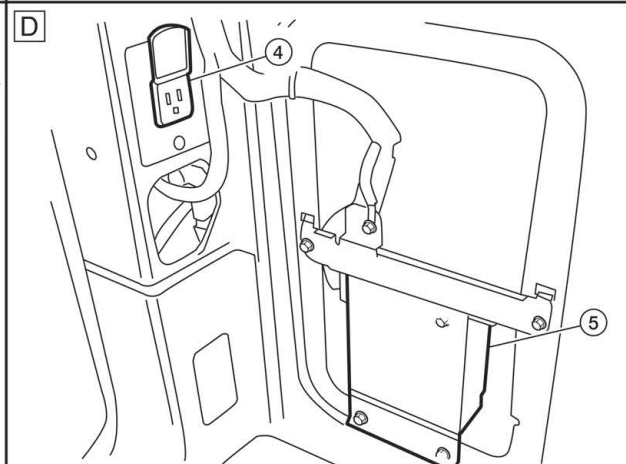
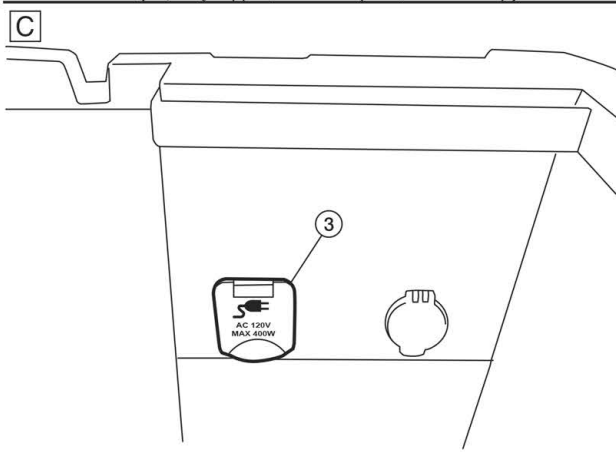
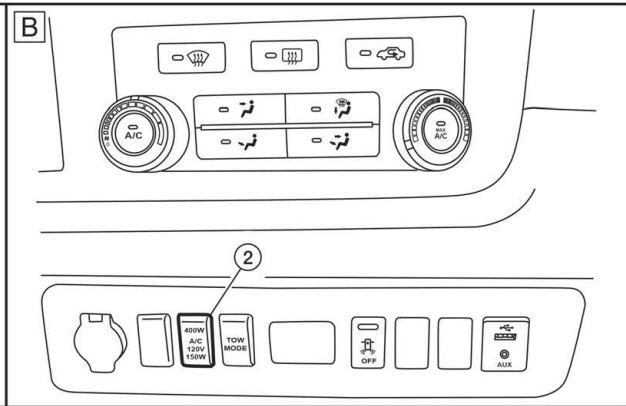
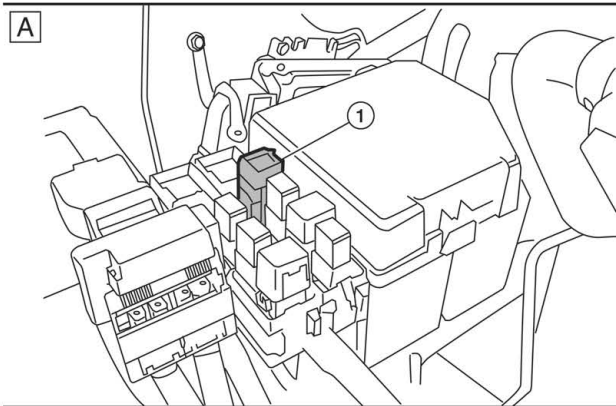
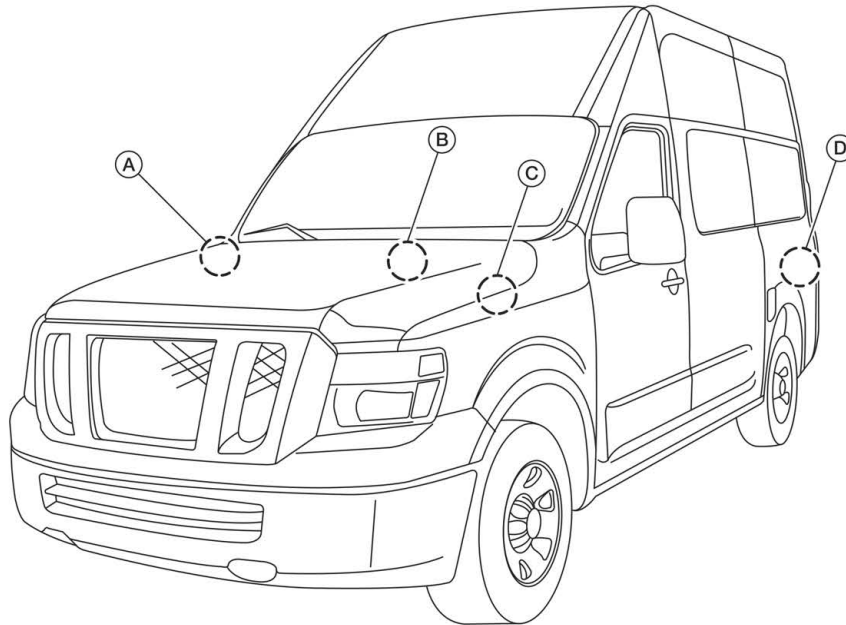

TGAAZIA0073ZZ

INVERTER SYSTEM

[ELECTRICAL]

1. Inverter relay (view with relay box cover removed)
2. AC 120 V outlet main switch
3. AC 120 V outlet front (inside center console)
4. AC 120 V outlet rear
5. Inverter unit (view with left rear finisher panel removed)

INVERTER SPECIFICATIONS

Rated voltage output		AC 120-volt ($\pm 10\%$)
Operating voltage range		DC 11.5-volt to 15-volt (Inverter terminal)
Rated power output	Low power mode	150-watt
	High power mode	400-watt
Output over-current protection	High power mode	3.7A or more
Input over-current protection	Low power mode	13.3A or more
Output frequency		60Hz ($\pm 10\%$)
Parasitic current		Less than 1 mA
Max. input current		45A (during continuous power)
Rated continuous power		400-watt @ 40°C (104°F) Maximum
Overheat protection (Thermistor)		100°C (212°F)

REMOTE KEYLESS ENTRY SYSTEM

System Description

If a key fob is lost, a new key fob can be set up. A maximum of 5 IDs can be set up simultaneously.

Key fob ID Setup

For key fob ID set up and programming, it is recommended to go to an authorized NISSAN dealer.

FUEL SYSTEMS

FUEL SYSTEM PRECAUTIONS

General

Modifications in the fuel system are not recommended, either in the circuit or the components.

 **WARNING:**

When replacing fuel line parts, be sure to observe the following:

- Put a "CAUTION: FLAMMABLE" sign in the workshop.
- Be sure to work in a well-ventilated area and furnish workshop with a CO2 fire extinguisher.
- Do not smoke while servicing fuel system. Keep open flames and sparks away from the work area.

 **WARNING:**

Before removing fuel line parts, carry out the following procedures:

- Put drained fuel in an explosion-proof container and put the lid on securely. Keep the container in safe area.
- Release fuel pressure from the fuel lines. Refer to the [Fuel Pressure Release Procedure \(pg. 272\)](#) in this section.
- Disconnect the battery negative terminal.
- Always replace O-rings and clamps with new ones.
- Do not kink or twist hoses when they are being installed.
- After connecting the fuel tube quick connectors, make sure the quick connectors are secure. Ensure that the connector and resin tube do not contact any adjacent parts.
- After installing tubes, make sure there is no fuel leakage at connections in the following steps:
 - Ignition switch ON to apply fuel pressure to fuel lines (with engine stopped). Then check for fuel leaks at connections.
 - Start the engine and rev it up and check for fuel leaks at connections.
- Use only a Genuine NISSAN fuel filler cap as a replacement. If an incorrect fuel filler cap is used, the MIL may come on.
- For servicing Evaporative Emission System parts, refer to the EC section in the service manual.
- For servicing On Board Refueling Vapor Recovery (ORVR) parts, refer to the EC section in the service manual.

Connection (cross-section)

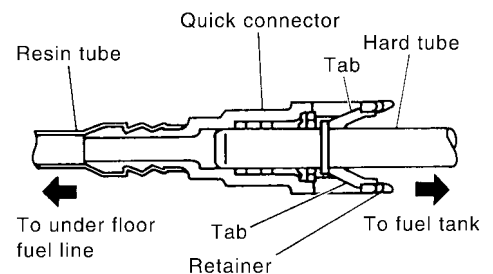

Disconnection

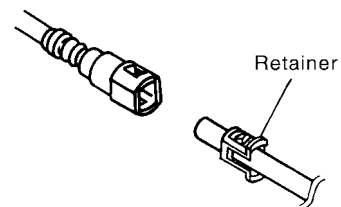

Fuel Pressure Release Procedure

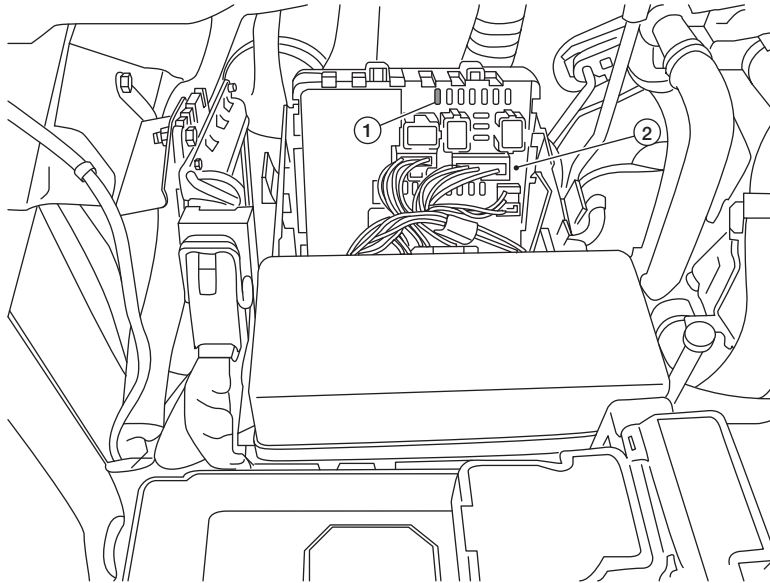

AAZIA0113ZZ

1. Fuel pump fuse

2. Intelligent Power Distribution Module Engine Room (IPDM E/R)

1. Remove fuel pump fuse (1) located in IPDM E/R (2). Refer to [Fuse and Relay Information \(pg. 221\)](#) for fuse layout.
2. Start engine.
3. After engine stalls, crank it two or three times to release all fuel pressure.
4. Ignition switch OFF.
5. Reinstall fuel pump fuse after servicing fuel system.

FILLER NECK AREAS

Chassis

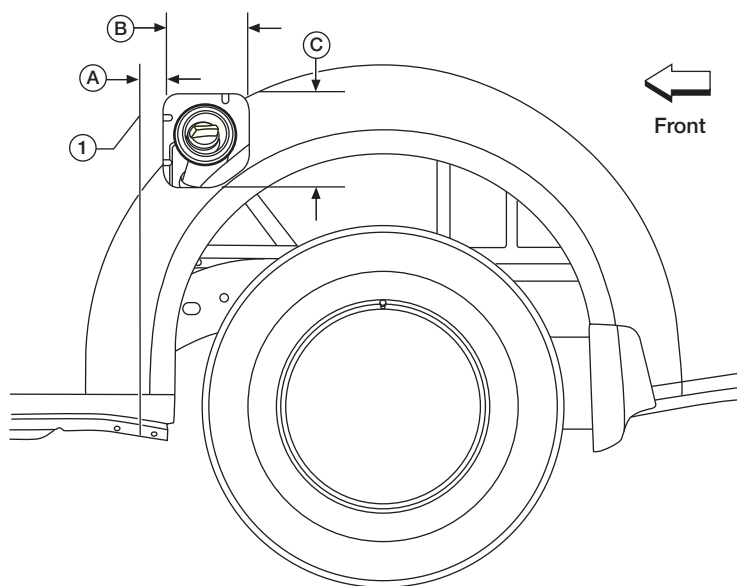

AAZIA0001ZZ

- 1. Body panel seam
- C. 205 mm (8.07 in)

A. 46 mm (1.81 in)

B. 190 mm (7.48 in)

Fuel Filler Pipe and EVAP Canister Location

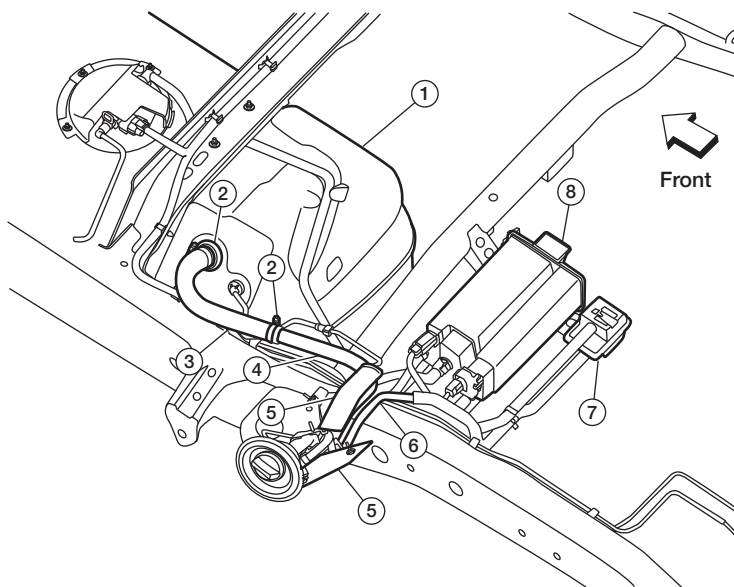

- 1. Fuel tank
- 4. Fuel filler pipe
- 7. EVAP canister filter

- 2. Clamp
- 5. Filler tube protector
- 8. EVAP canister assembly

- 3. Fuel filler hose
- 6. EVAP vent tube

AAZIA0221GB

TANK LOCATION

Tank Mounting

NOTE:

Fuel tank shown without fuel tank protector and frame brackets (vehicles built 08/2014 or later only).

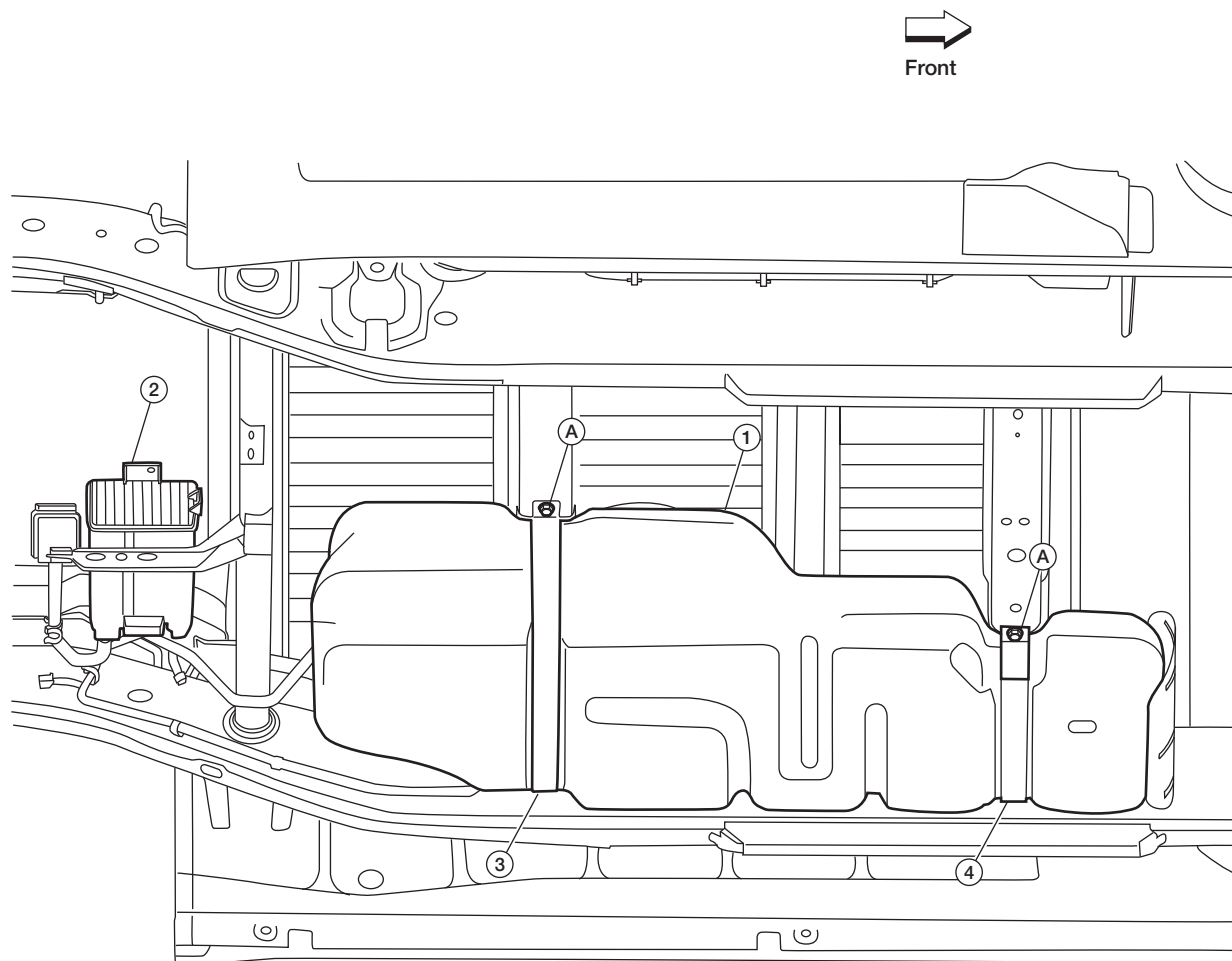

- 1. Fuel tank
- 4. Front tank strap

- 2. EVAP canister assembly
- A. Fuel tank strap bolts

- 3. Rear tank strap

AAZIA0222GB

Drilling Precaution Area**WARNING:**

Do not damage the fuel tank or lines when drilling through the floor in the areas shown or component failure and personal injury may occur.

**CAUTION:**

When any vehicle modifications are performed, check for proper clearance between existing components or newly installed components. Failure to do so may result in vehicle or component damage.

TANK LOCATION

[FUEL SYSTEMS]

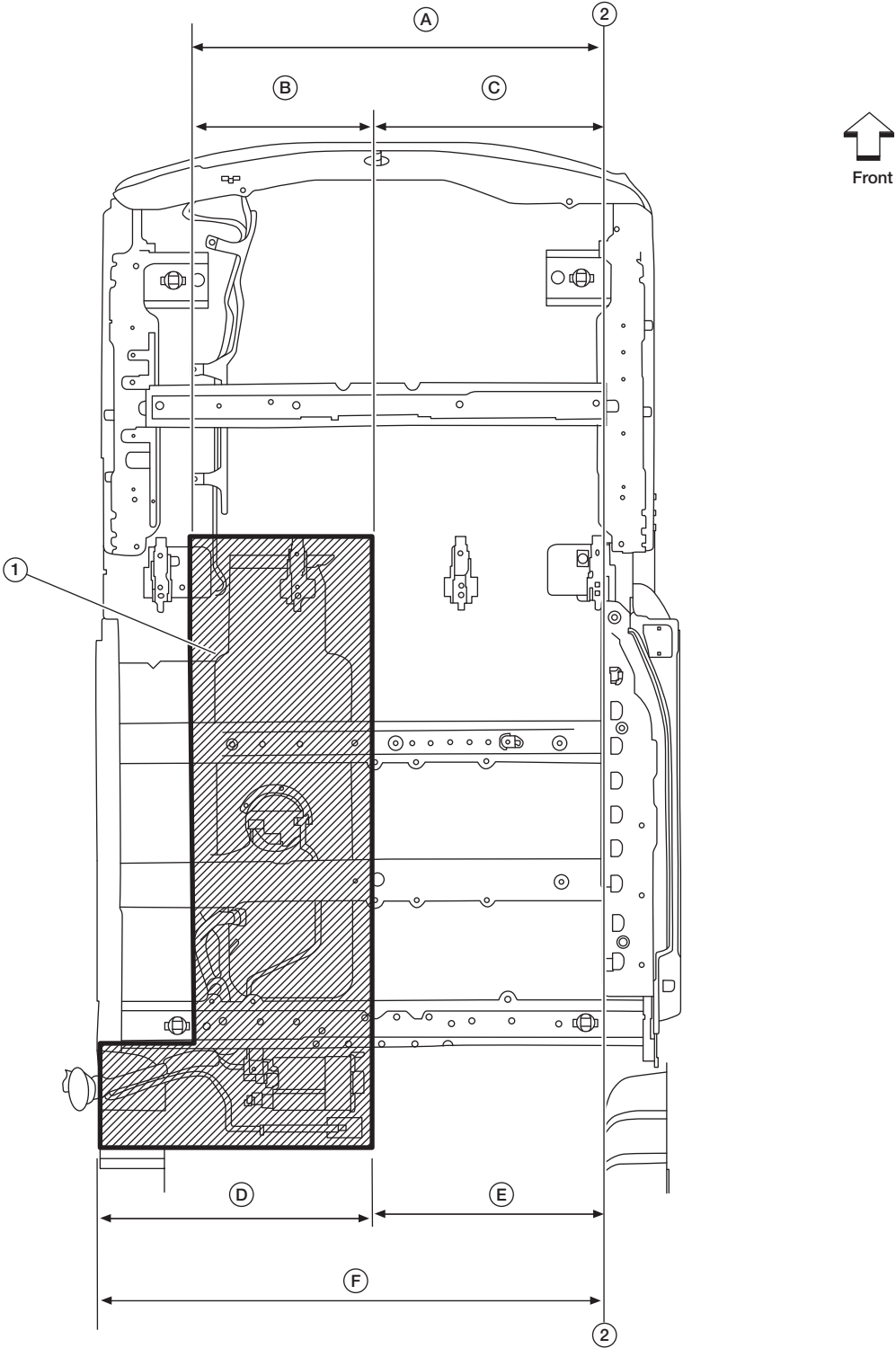

AAZIA0065ZZ

NOTE:
All dimensions and reference lines are shown with cargo mat removed.

TANK LOCATION

[FUEL SYSTEMS]

1. Fuel tank drill precaution zone

A. 1,312.39 mm (51.67 in)

D. 860.81 mm (33.89 in)

2. Slide door step edge (reference line)

B. 576 mm (22.72 in)

E. 735.41 mm (28.95 in)

C. 735.41 mm (28.95 in)

F. 1,596 mm (62.84 in)

TANK LOCATION

[FUEL SYSTEMS]

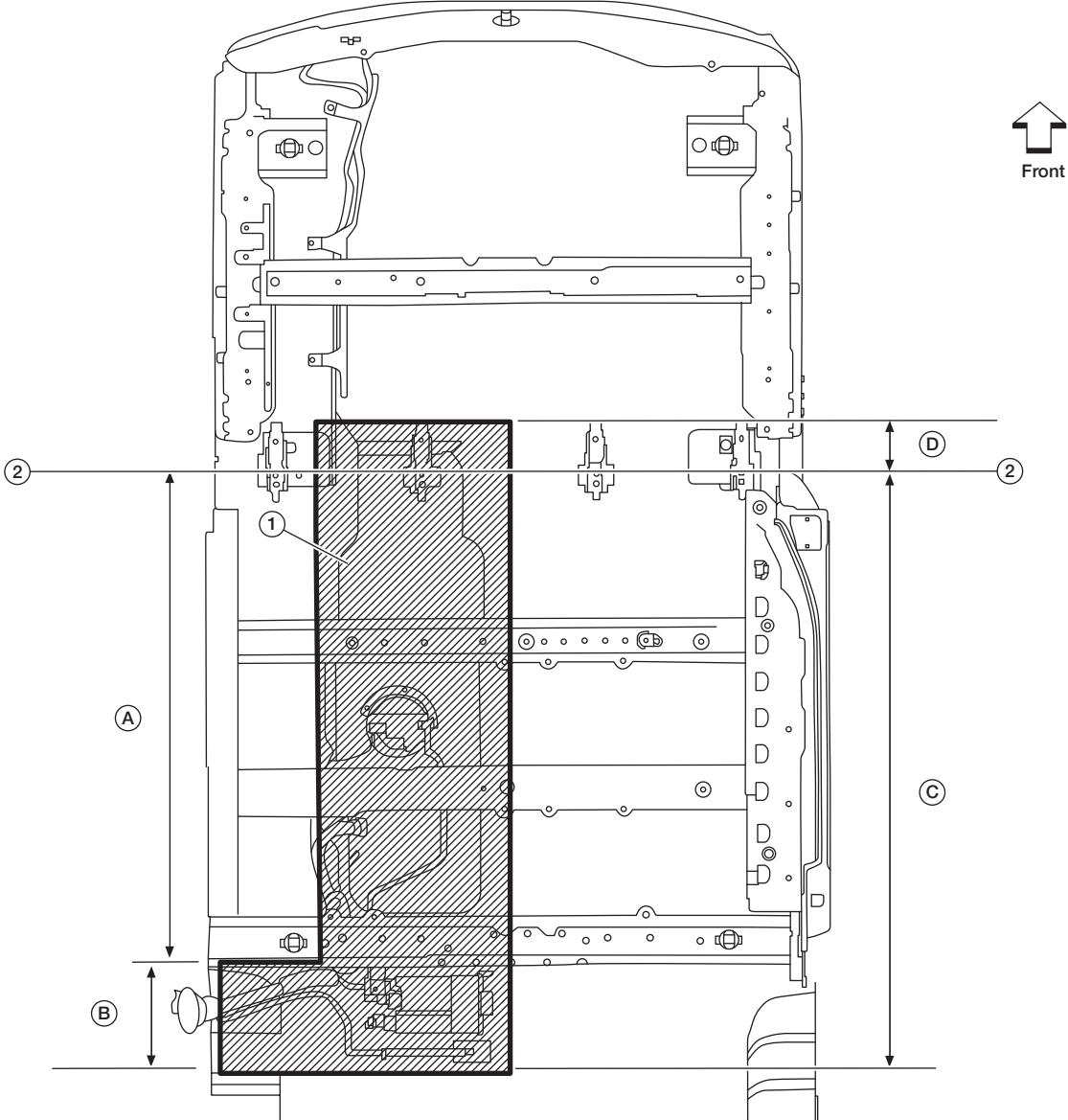

AAZIA0066ZZ

NOTE:
All dimensions and reference lines are shown with cargo mat removed.

TANK LOCATION

[FUEL SYSTEMS]

1. Fuel tank drill precaution zone

A. 1,429.55 mm (56.28 in)

D. 154.27 mm (6.07 in)

2. Front seat's rear mounting nuts (reference line)

B. 344.06 mm (13.55 in)

C. 1,773.61 (69.83 in)

TRAILER TOW

WIRING

Trailer Wiring

The optional factory-installed trailer tow package includes the necessary wiring, relays, and a 7-pin connector (mounted on the tow hitch at the rear of the vehicle). The vehicle-side connector will accommodate any standard 7-pin connector plug from your trailer.

NOTE:

If your vehicle was not equipped with the factory-installed trailer tow package, it is pre-wired to support a Genuine NISSAN accessory trailer wiring kit. To help ensure proper operation, Nissan recommends that only the Genuine NISSAN trailer wiring kit be used. Please contact your Authorized NISSAN Dealer for details. The accessory trailer wiring kit connects to the vehicle harness connector located behind the right front tire. Refer to the following illustration. For accessory trailer wiring kit installation instructions, refer to www.nissan-techinfo.com.

ENGINE HARNESS INLINE CONNECTOR

View behind right front tire with splash shield removed.

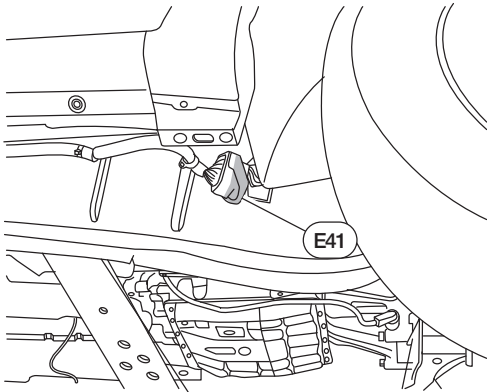

AAZIA0271GB

Connector No.	E41
Connector Name	WIRE TO WIRE
Connector Color	GRAY

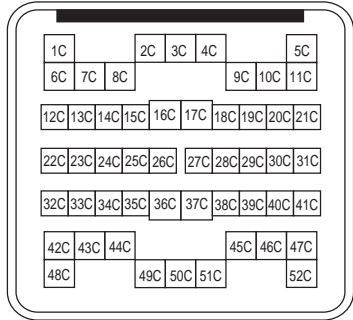

⚠ CAUTION:	Terminal No.	Color of Wire	Signal Name	Wire Gauge	Maximum Load
Do not allow total load across these circuits to exceed the maximum load for the ground circuit. Doing so may result in vehicle damage.	1C	Blue	Electric brake	12	24A
	4C	Black	Ground	8	40A
	6C	Light Green	Running lamps	18	8A
	8C	White	Stop/turn RH	18	6A
	11C	Green	Stop/turn LH	18	6A
	16C	Yellow	Back-up lamps	24	8A
	51C	Red	Ignition	12	24A

Trailer Connector

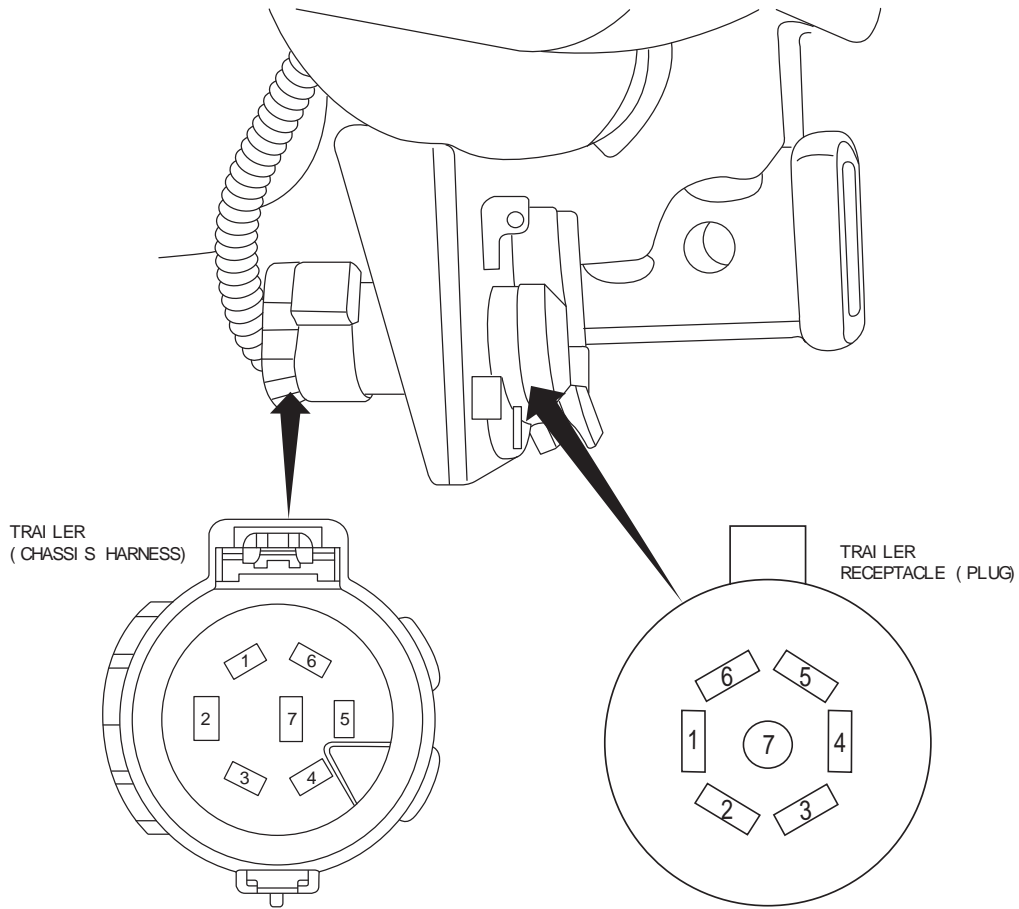

<p>⚠ CAUTION: Do not allow total load across these circuits to exceed the maximum load for the ground circuit. Doing so may result in vehicle damage.</p>	Terminal No.	Vehicle Harness Color of Wire	Signal Name	Maximum Load
	1	Green	Stop/turn LH	6A
	2	Black	Ground	40A
	3	Blue	Electric brake	24A
	4	White	Stop/turn RH	6A
	5	Red	Ignition	24A
	6	Light Green	Running lamps	8A
	7	Yellow	Back-up lamps	8A

AAZIA0254GB

Trailer Tow Component Locations

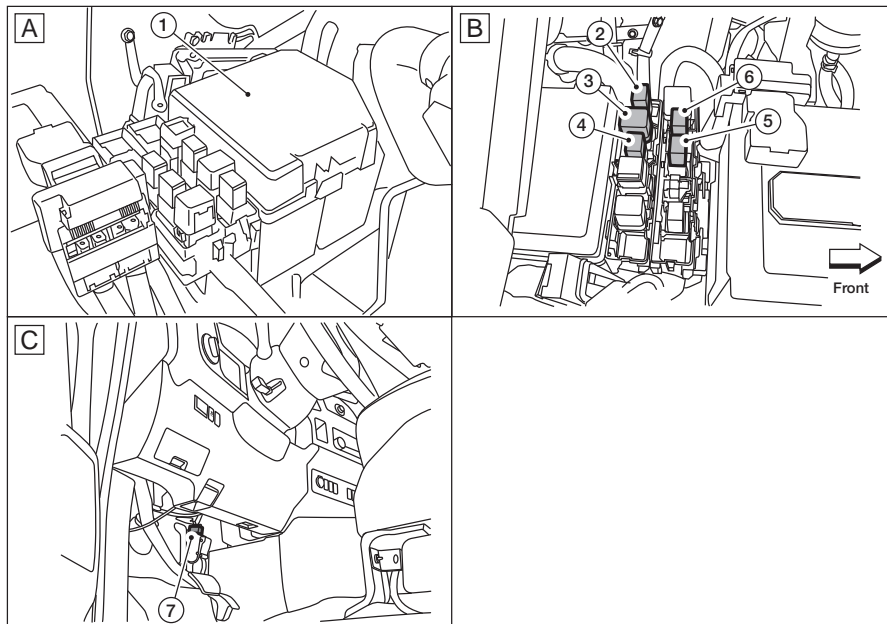
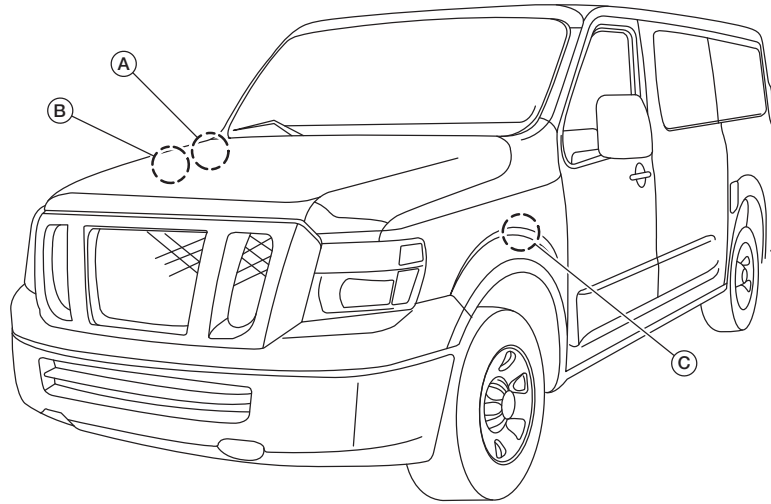

AAZIA0019ZZ

1. Intelligent Power Distribution Module Engine Room (IPDM E/R)

2. Stop lamp relay

3. Trailer tow relay 2

4. Trailer tow relay 1

5. Trailer turn relay LH

6. Trailer turn relay RH

7. Stop lamp switch

System Diagram

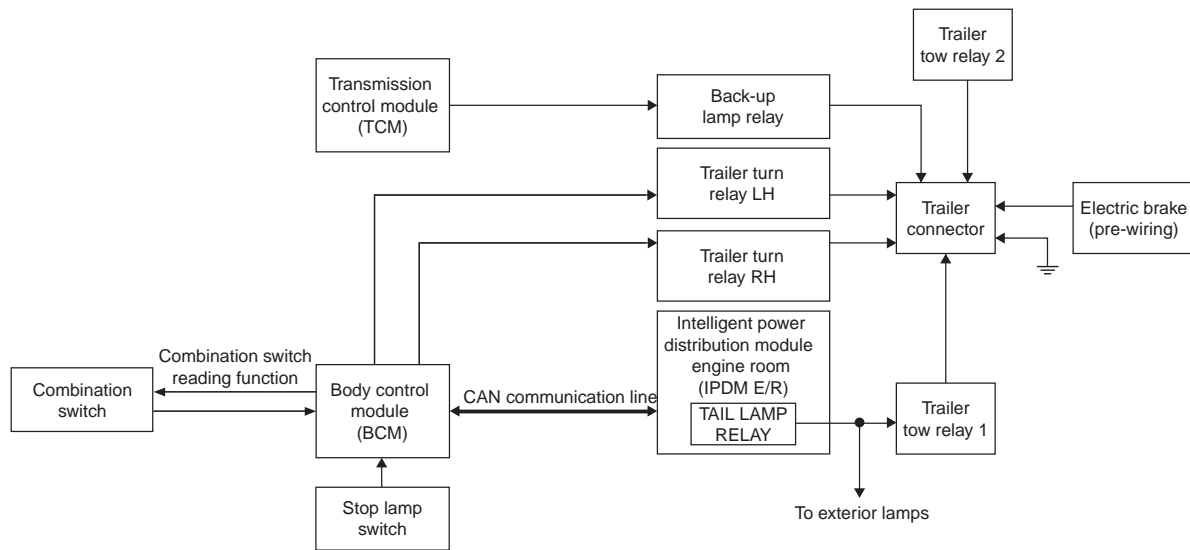

AAZIA0033GB

System Description

Trailer Tail Lamp Operation

The trailer tail lamps are controlled by the trailer tow relay 1. With the combination switch in the 1st position, the BCM detects the LIGHTING SWITCH 1ST POSITION ON. The BCM sends a parking light ON request via the CAN communication lines to the IPDM E/R. The IPDM E/R then activates the tail lamp relay which activates the trailer tow relay 1 and sends power to the trailer receptacle.

Trailer Turn Signal Lamp Operation

The trailer turn signal lamps are controlled by the BCM. When the turn signal switch is in the LH or RH position with the ignition switch ON, the combination switch sends a signal to the BCM. The BCM detects the TURN RH ON or TURN LH ON request. The BCM sends a control signal to the respective trailer turn relay which sends power to the trailer receptacle.

Trailer Hazard Lamp Operation

The trailer hazard lamps are controlled by the BCM. When the hazard switch is pressed, the BCM detects the HAZARD ON request. The BCM then sends a control signal to both trailer turn relays which sends power to the trailer receptacle.

Trailer Brake Lamp Operation

The trailer brake lamps are controlled by the BCM. When the brake pedal is depressed, the BCM receives a stoplamp switch signal from the stoplamp switch. The BCM then sends a control signal to both trailer turn relays which sends power to the trailer receptacle.

Trailer Reverse Lamp Operation

The trailer reverse lamps are controlled by the TCM. When the shift selector is placed in Reverse (R) the TCM receives a reverse signal from the transmission range switch. The TCM then sends a control signal to the back-up lamp relay, which sends power to the trailer receptacle.

BRAKE CONTROLLER

This vehicle may be equipped with either the factory-installed trailer tow package or a Genuine NISSAN accessory trailer wiring kit. This vehicle also includes a 6-pin connector and an electronic brake (pre-wiring) jumper harness (with trailer tow) with specific circuits to support an aftermarket brake controller. The connector is located in the passenger compartment on the driver's side, taped back to the engine room harness near the dash grommet.

Electric Brake (Pre-wiring) Connector

ELECTRIC BRAKE PREWIRING

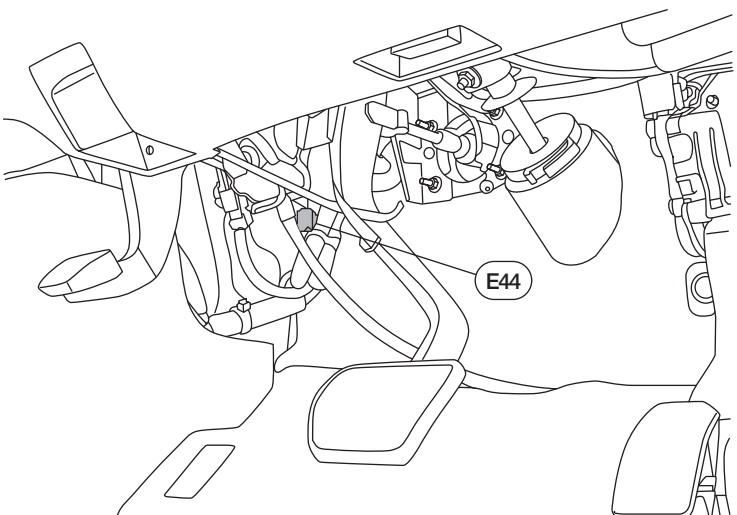

Connector No.	E44
Connector Name	ELECTRIC BRAKE (PRE-WIRING)
Connector Color	WHITE

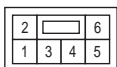

Terminal No.	Color of Wire	Signal Name	Wire Gauge
1	Black	GND	14
2	Light Green	STOP LAMPS	23
3	Blue	TRAILER BRAKE	14
5	Red	B+	14

Connector No.	E62
Connector Name	ELECTRIC BRAKE (PRE-WIRING) (JUMPER HARNESS SIDE)
Connector Color	WHITE

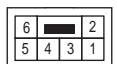

Terminal No.	Color of Wire	Signal Name
1	Black	GND
2	Red/Green	STOP LAMPS
3	Brown/White	TRAILER BRAKE
4	Red/Blue	ILLUMINATION (NOT USED)
5	Red	B+

AAZIA0255GB

TRAILER HITCH

Adding A Hitch



WARNING:

- **Special hitches, which include frame reinforcements, are required for towing above 907 kg (2,000 lbs). Suitable Genuine NISSAN hitches, ball mounts and hitch balls are available through an authorized NISSAN dealer.**
- **The hitch should not be attached to or affect the operation of the impact absorbing bumper.**
- **Do not use axle-mounted hitches.**
- **Do not modify the vehicle exhaust system, brake system, etc., to install a trailer hitch.**
- **To reduce the possibility of additional damage if your vehicle is struck from the rear, where practical, remove the receiver when not in use.**
- **Regularly check that all trailer hitch mounting bolts are securely mounted.**
- **When towing with the hitch ball mounted to the rear bumper, do not make sharp turns. The trailer may contact the bumper and cause damage to the bumper or trailer.**

Weight Distribution Hitch

This type of hitch is also called a "load-leveling" or "equalizing hitch". A set of bars attach to the ball mount and to the trailer to distribute the tongue weight (hitch weight) of your trailer. Many vehicles can't carry the full tongue weight of a given trailer and need some of the tongue weight transferred through the frame and through pushing down on the front wheels. This gives stability to the tow vehicle. A weight distributing hitch system (Class IV) is recommended if you plan to tow trailers with a maximum weight of over 2,267 kg (5,000 lbs). Check with the trailer and towing equipment manufacturers to determine if they recommend the use of a weight distributing hitch system.

NOTE:

A weight distributing hitch system may affect the operation of the trailer surge brakes. If you are considering the use of a weight distributing hitch system with a surge brake-equipped trailer, check with the surge brake, hitch or trailer manufacturer to determine if and how this can be done.

Follow the instructions provided by the manufacturer for installing and using the weight distributing hitch system.

General setup instructions are as follows:

1. Park the unloaded vehicle on a level surface. With the ignition ON and the doors closed, allow the vehicle to stand for several minutes so that it can level.
2. Measure the height of a reference point on the front and rear bumpers at the center of the vehicle.
3. Attach the trailer to the vehicle and adjust the hitch equalizers so that the front bumper height is within 13 mm (0.6 in) of the reference height measured in step 2. The rear bumper should be no higher than the reference height measured in step 2.



WARNING:

Properly adjust the weight distributing hitch so that the rear of the bumper is no higher than the measured reference height when the trailer is attached. If the rear bumper is higher than the measured reference height when loaded, the vehicle may handle unpredictably, which could cause a loss of vehicle control and cause serious personal injury or property damage.

Sway Control Device

Sudden maneuvers, wind gusts, and buffeting caused by other vehicles can affect trailer handling. Sway control devices may be used to help control these effects. If you choose to use one, contact a reputable trailer hitch supplier to make sure that the sway control device will work with the vehicle, hitch, trailer and the trailer's brake system. Follow the instructions provided by the manufacturer for installing and using the sway control device.

Class I Hitch

The Genuine NISSAN step bumper is considered a Class I ball mount. It can be used to tow trailers with a maximum weight of 907 kg (2,000 lbs).

Class II Hitch

Class II trailer hitch equipment (receiver, ball mount and hitch ball) can be used to tow trailers with a maximum weight of 1,587.3 kg (3,500 lbs).

Class III Hitch

Class III trailer hitch equipment (receiver, ball mount and hitch ball) can be used to tow trailers with a maximum weight of 2,267 kg (5,000 lbs).

Class IV Hitch

Class IV trailer hitch equipment (receiver, ball mount and hitch ball) can be used to tow trailers with a maximum weight of 4,535 kg (10,000 lbs). A weight distributing hitch should be used to tow trailers that weigh over 2,267 kg (5,000 lbs). Your vehicle may be equipped with Class IV trailer hitch equipment that has a 4,535 kg (10,000 lbs) maximum weight rating, but your vehicle is only capable of towing up to the maximum trailer weights given in the chart. Find the GCWR for the vehicle. Refer to the appropriate Weights chart in [RESOURCE CHARTS \(pg. 94\)](#).

Trailer Hitch Mounting Hole Dimensions

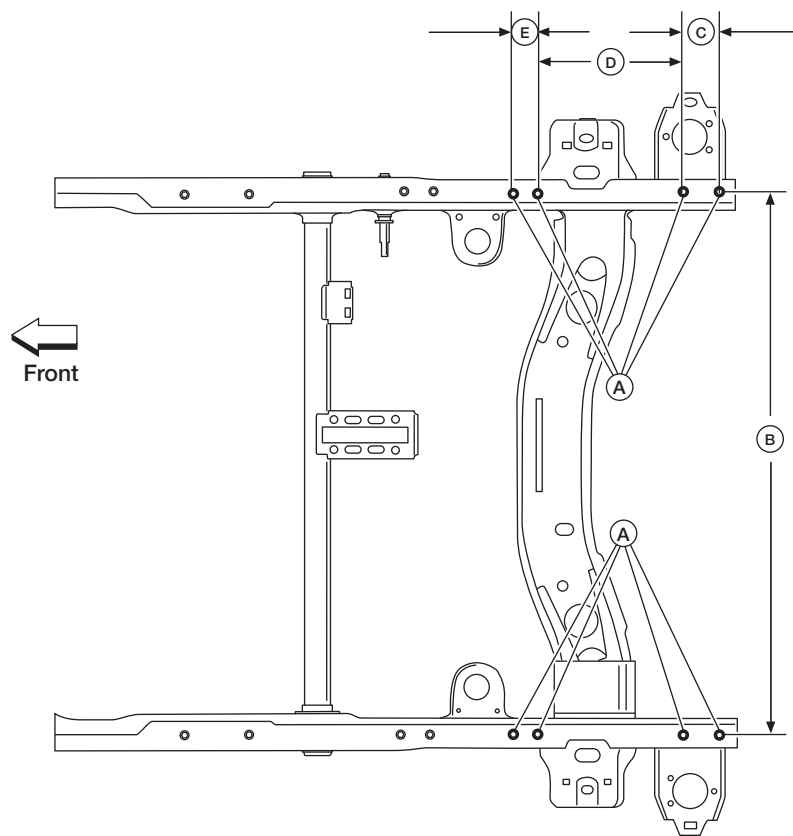

AAZIA0046ZZ

A. Hitch mount weld nuts
M12 x 1.25
D. 300.95 mm (11.85 in)

B. 1,118.36 mm (44.03 in)
E. 50.19 mm (1.98 in)

C. 74.91 mm (2.95 in)

DESIGN REQUIREMENTS FOR MODIFICATIONS

COOLING

Engine Cooling System

**CAUTION:**

No modification to the engine cooling system (radiator, radiator shroud, cooling fans, liquid cooling circuit, etc.) is allowed. Sufficient air passage to the radiator must be maintained, therefore, do not block the air passage through the radiator grille to the radiator with publicity plates, posters, trim or other decorative elements. Reduced air flow can cause overheating and could lead to component damage.

HVAC

Changes To The HVAC System

Changes to the HVAC system are not recommended. For liquid connection information, service data and specifications, refer to the service manual.

HVAC System Component Locations

MANUAL AIR CONDITIONING SYSTEM

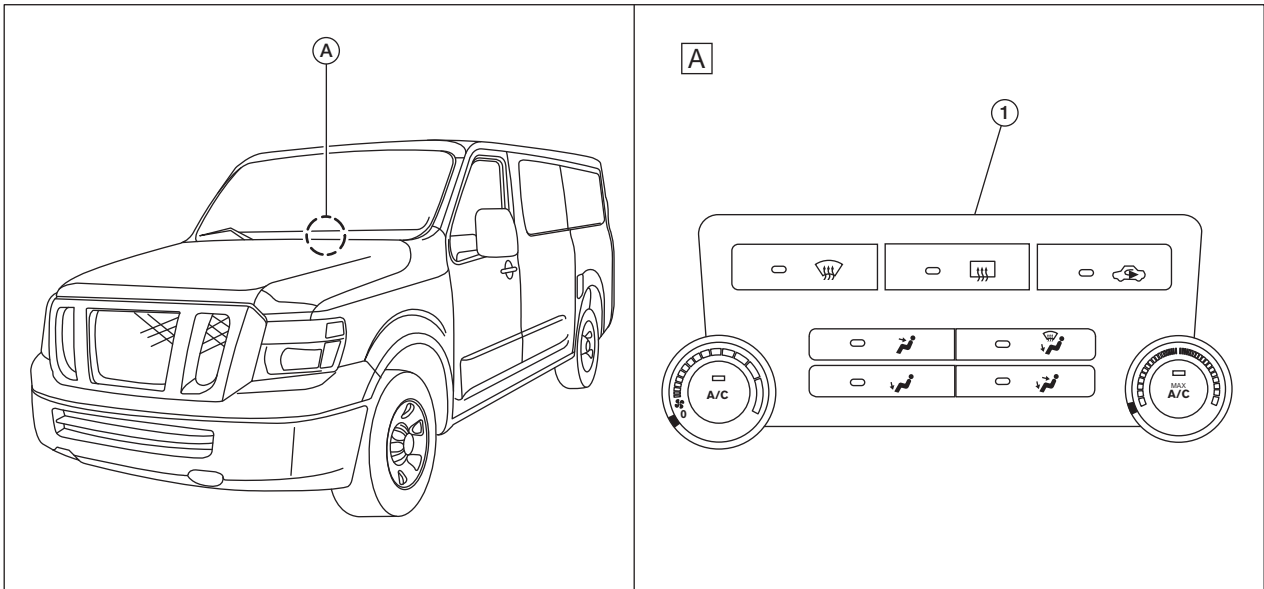

AAZIA0079ZZ

1. Front air control

SONAR SYSTEM

[DESIGN REQUIREMENTS FOR MODIFICATIONS]

SONAR SYSTEM

Rear Sonar System

Component Parts Location

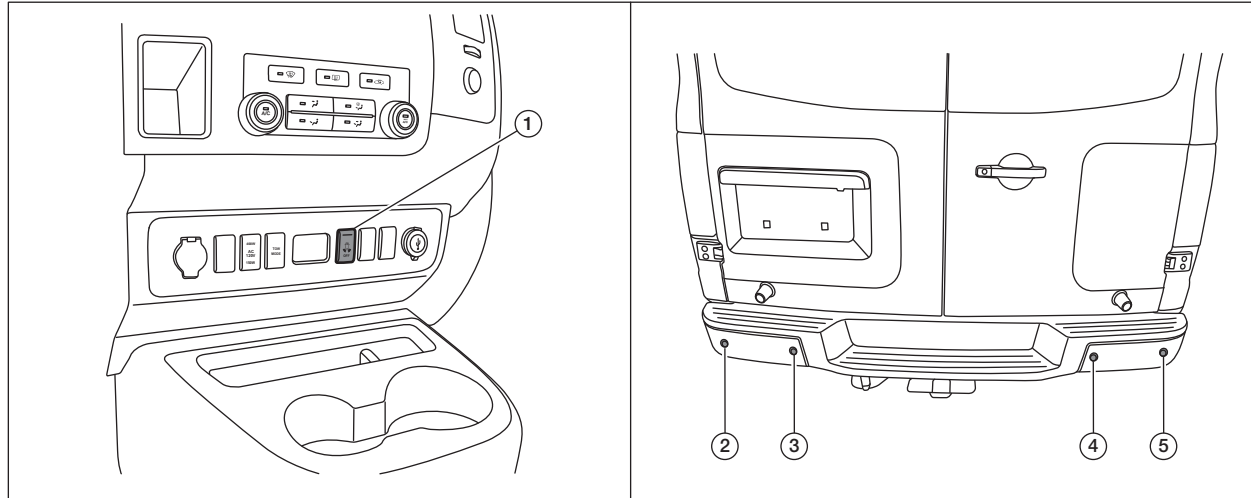

AAZIA0024ZZ

1. Sonar system OFF switch
(with sonar system OFF
indicator)

2. Rear sonar sensor LH outer

3. Rear sonar sensor LH inner

4. Rear sonar sensor RH inner

5. Rear sonar sensor RH outer

Sensor Layout Dimensions

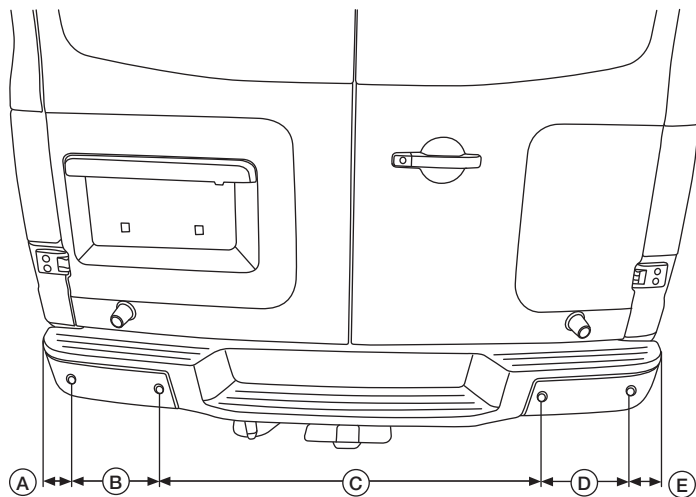

AAZIA0021ZZ

A. 140 mm (5.5 in)

B. 285 mm (11.2 in)

C. 1,110 mm (43.7 in)

D. 285 mm (11.2 in)

E. 140 mm (5.5 in)

SONAR SYSTEM

[DESIGN REQUIREMENTS FOR MODIFICATIONS]

Rear Sonar System Detection Area

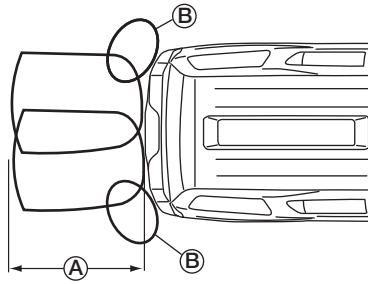

AAZIA0253GB

A. 1,800 mm (70.87 in)

B. Decreased coverage area



CAUTION:

Do not install objects that interfere with the zone specified and the ability of the sonar system to function properly.

The Rear Sonar System (RSS) sounds a tone to warn the driver of obstacles near the rear bumper when the shift selector is in R (Reverse). The system may not detect objects at speeds above 5 km/h (3 mph) and may not detect certain angular or moving objects.

The RSS detects obstacles up to 1.8 m (5.9 feet) from the rear bumper (A) with a decreased coverage area at the outer corners of the bumper (B) (refer to the illustration for approximate zone coverage areas). As you move closer to the obstacle, the rate of the tone increases. When the obstacle is less than 25.0 cm (10 inches) away, the tone will sound continuously. If the RSS detects a stationary or receding object further than 25.0 cm (10 inches) from the side of the vehicle, the tone will sound for only three seconds. Once the system detects an object approaching, the tone will sound again.

The RSS automatically turns on when the shift selector is placed in R (Reverse) and the ignition is ON. The RSS OFF switch on the instrument panel allows the driver to turn the RSS on and off. To turn the RSS off, the ignition must be ON, and the shift selector in R (Reverse). An indicator light on the switch will illuminate when the system is turned off. If the indicator light illuminates when the RSS is not turned off, it may indicate a malfunction in the RSS.

EXHAUST

[DESIGN REQUIREMENTS FOR MODIFICATIONS]

EXHAUST

Exhaust System

Changes to the exhaust system are not recommended.

VQ40DE (4.0L) Exhaust System

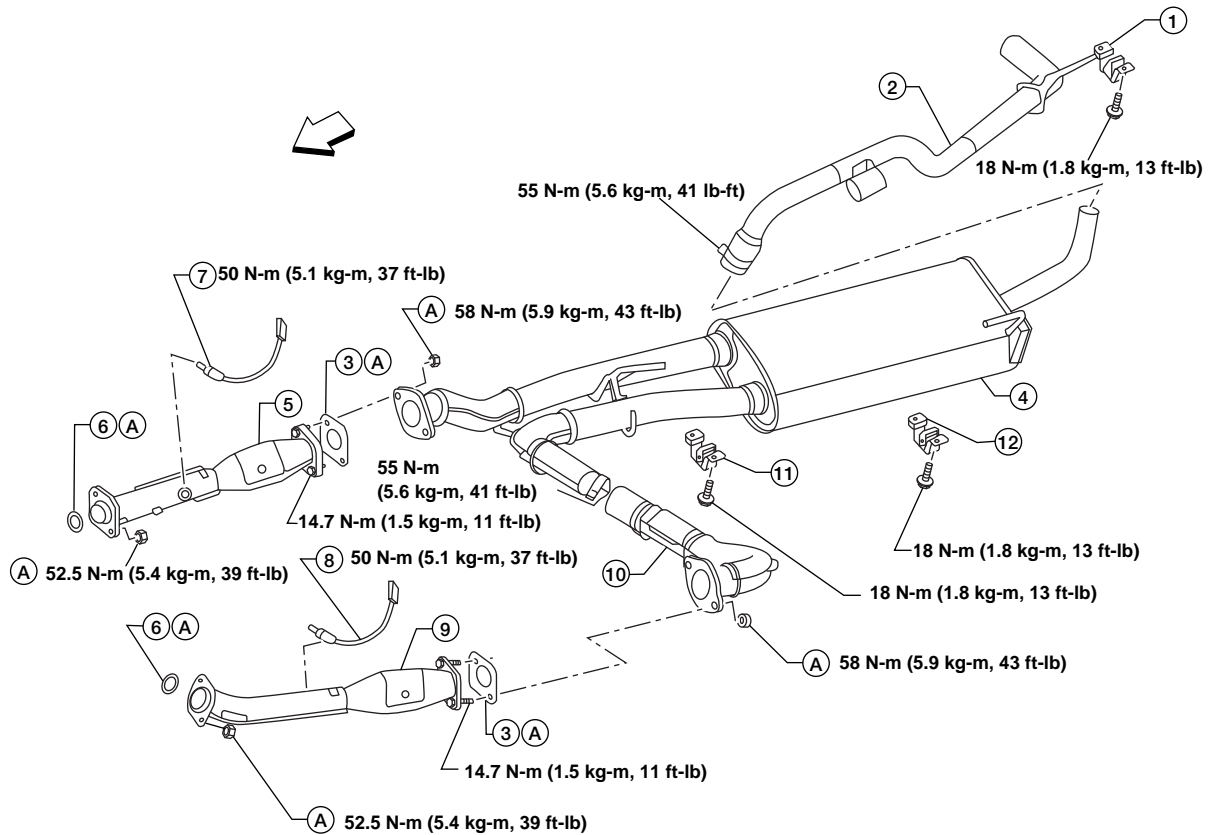

AAZIA0363ZZ

← : Front of vehicle.

1. Tailpipe hanger bracket

2. Tailpipe

3. Gasket

4. Main muffler

5. Right front exhaust tube

6. Ring gasket

7. Heated oxygen sensor 2
(bank 1) (RH)

8. Heated oxygen sensor 2
(bank 2) (LH)

9. Left front exhaust tube

10. Center exhaust tube

11. Muffler hanger bracket front

12. Muffler hanger bracket rear

A. Always replace after every
disassembly

EXHAUST

[DESIGN REQUIREMENTS FOR MODIFICATIONS]

VK56DE (5.6L) and VK56VD (5.6L) Exhaust System

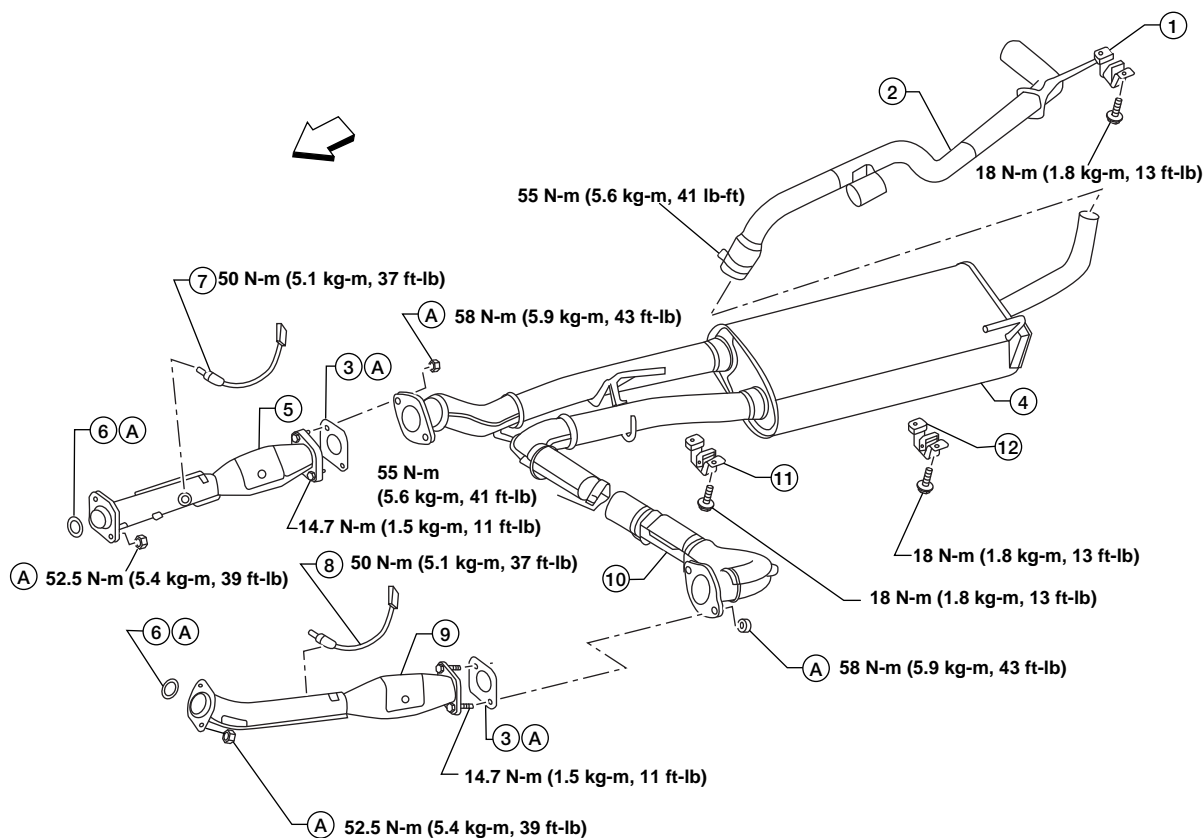

AAZIA0363ZZ

←: Front of vehicle.

1. Tailpipe hanger bracket

2. Tailpipe

3. Gasket

4. Main muffler

5. Right front exhaust tube

6. Ring gasket

7. Heated oxygen sensor 2 (bank 2) (RH)

8. Heated oxygen sensor 2 (bank 1) (LH)

9. Left front exhaust tube

10. Center exhaust tube

11. Muffler hanger bracket front

12. Muffler hanger bracket rear

A. Always replace after every disassembly

EXHAUST

[DESIGN REQUIREMENTS FOR MODIFICATIONS]

Exhaust Measurements

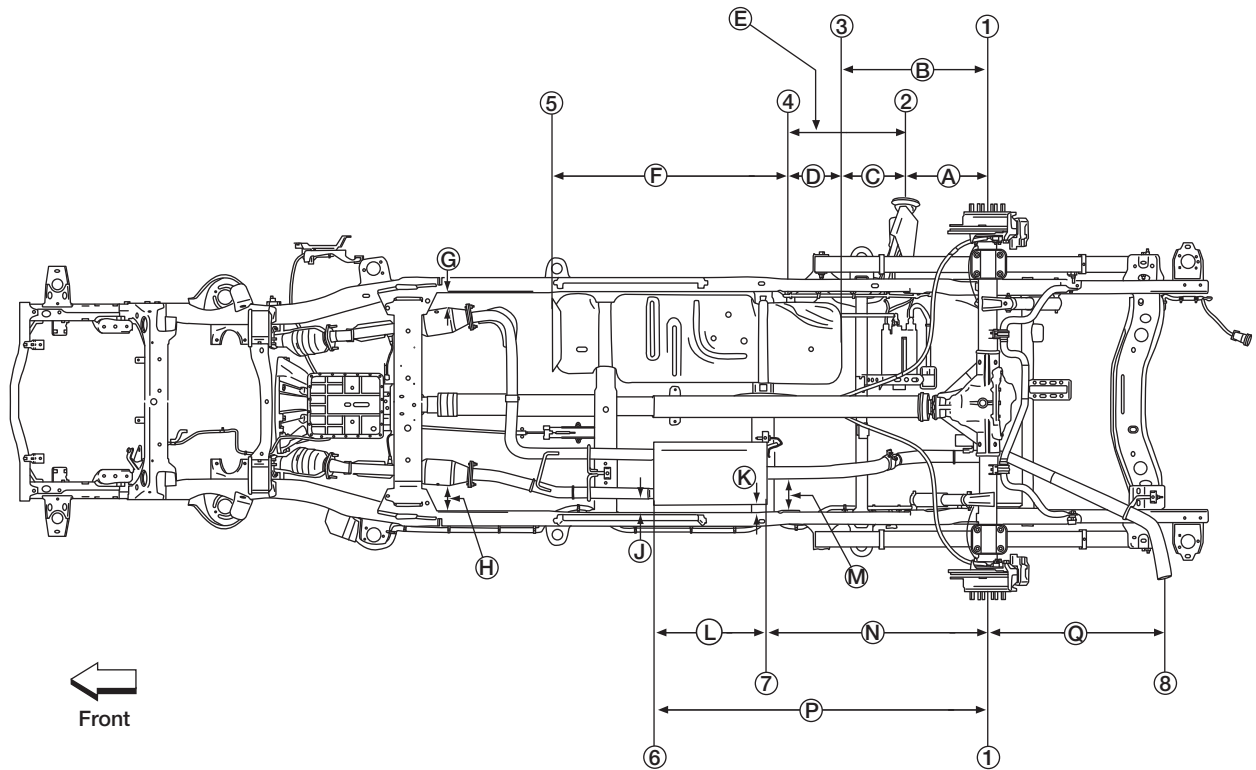

AAZIA0051ZZ

NOTE:

Shown as viewed from below.

- | | | |
|---|-----------------------------|---------------------------|
| 1. Center line of rear axle | 2. Center of fuel filler | 3. Rear edge of fuel tank |
| 4. Center of fuel tank filler neck connection | 5. Front edge of fuel tank | 6. Front edge of muffler |
| 7. Rear edge of muffler | 8. Center of exhaust outlet | A. 395 mm (15.6 in) |
| B. 705 mm (27.8 in) | C. 310 mm (12.2 in) | D. 248 mm (9.8 in) |
| E. 557 mm (21.9 in) | F. 1,150 mm (45.3 in) | G. 76 mm (3 in) |
| H. 123 mm (4.8 in) | J. 64 mm (2.5 in) | K. 26 mm (1 in) |
| L. 549 mm (21.6 in) | M. 155 mm (6.1 in) | N. 1,165 mm (45.9 in) |
| P. 1,614 mm (63.5 in) | Q. 851 mm (33.5 in) | |



CAUTION:

To prevent exhaust gas leaks and possible CO poisoning:

- Always replace exhaust gaskets and ring gaskets with new ones when reassembling.
- Temporarily tighten the nuts on the front and rear of the left front exhaust tube and right front exhaust tube. Check each part for interference with other components, and then tighten the nuts and bolts to specification.
- When connecting the muffler assembly/tailpipe assembly joint make sure that it is not over-installed.

EXHAUST [DESIGN REQUIREMENTS FOR MODIFICATIONS]

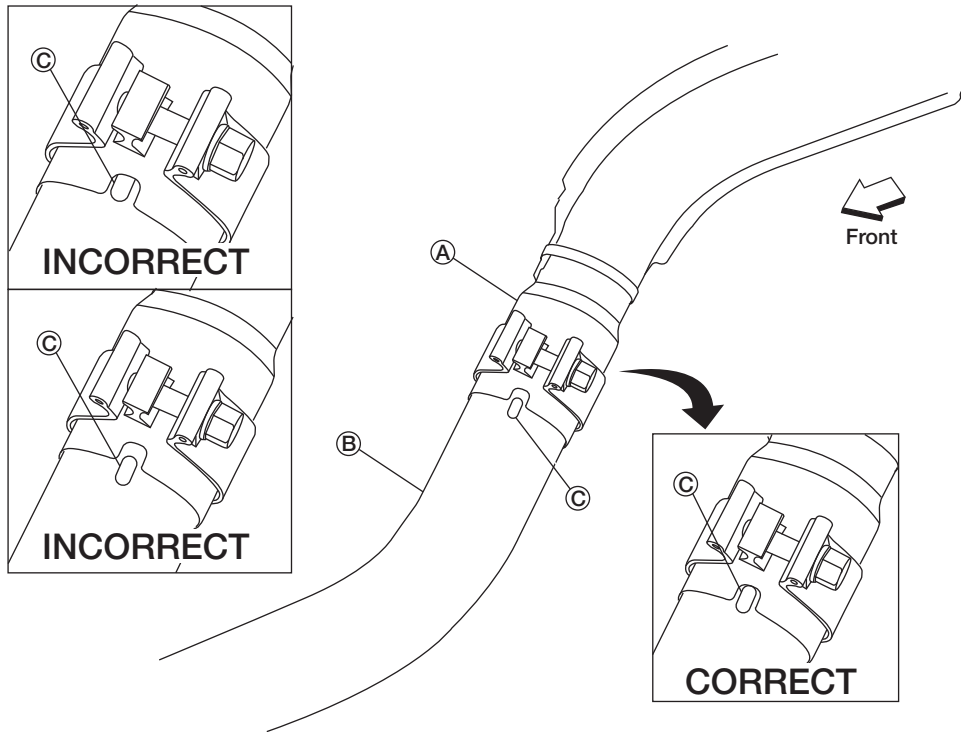

AAZIA0270GB

A. Tailpipe inlet

B. Muffler outlet

C. Dimple

Be sure to align dimple in the exhaust pipe C with notch in the tailpipe inlet A.

Inspection After Installation

- With the engine running, check exhaust tube joints for gas leakage and unusual noises.
- Check to ensure that mounting brackets and rubber insulators are installed properly and free from undue stress. Improper installation could result in excessive noise and vibration.

WHEEL AND TIRE

General

The replacement of the tires with those other than the ones indicated by Nissan is not recommended. Using tires of different make, size, type or characteristics on the same axle is not allowed. Using non-recommended tires could affect the performance of the Vehicle Dynamic Control (VDC) or other vehicle components.

STEERING AND SUSPENSION

Vehicle Handling Information



WARNING:

- Changes made to the vehicle that significantly affect the ride height may cause vehicle control problems during sharp turns or sudden steering maneuvers. Any maneuvers of this type could result in an accident. The steering gear, intermediate shaft, coupling shaft, linkage, column, and steering wheel should not be altered or relocated. Steering linkage travel should not be restricted.



WARNING:

- Because the heat from welding on or near the suspension or steering components may damage or weaken the components, it is not authorized.
- Welding equipment should not be grounded to any of the suspension components.
- Any new components attached to the steering column or its components must not interfere with the steering column performance during either normal operation or crash situations.
- New components and/or the vehicle load must not exceed the front and rear GAWRs or the GVWR.

NOTE:

The aftermarket equipment manufacturer, second stage manufacturer, and upfitter are responsible for maintaining or restoring the front wheel alignment after modifications to the vehicle are complete. The straight ahead orientation of the steering wheel must be maintained when re-adjusting the front wheel alignment. Changes to the vehicle center of gravity will affect handling. The upfitter is responsible for maintaining compliance with the Federal or Canada Motor Vehicle Safety Standards and Nissan guidelines in regards to the center of gravity and vehicle handling characteristics.

DRIVELINE



CAUTION:

- The rear axle vent hose must not be bent, pinched, or obstructed, as the rear axle could be damaged or malfunction.
- Any deviation from Nissan specifications may adversely affect powertrain operation, including engine, transmission, or component reliability. The aftermarket equipment manufacturer, second stage manufacturer, and upfitter are responsible for maintaining the specifications after the completion of any modifications.
- Additional brackets, bars, or supports [including an equalizing-type trailer hitch or auxiliary suspension systems (springs)] must not be welded to the axle assembly.

TRANSMISSION



CAUTION:

- The engine and transmission position relative to the shift linkage must not be altered.
- The transmission vent must not be altered, pinched, collapsed, restricted or relocated.
- The spacing for tool access for transmission adjustments or removal must be maintained.
- Transmission oil cooler lines should not be kinked, bent, or restricted. All oil cooler lines must be properly retained with adequate clips.
- The shift cable, external transmission shift lever, and shift cable bracket must not be altered.
- Transmission identification tags must not be removed or destroyed.
- All transmission wire harness routing, locating clips, heat shielding, and clearance to the exhaust must be maintained as installed by the factory.

FRAME



WARNING:

Failure to follow the recommendations below may weaken the vehicle frame, which could result in death or serious injury.

- Do not weld on any part of the frame.
- Do not modify or alter the front crush horns. Modifications or alterations could adversely affect the vehicle in a crash.
- Only use Genuine NISSAN front tow hooks.
- Drilling holes in the frame is not authorized.

JACK

[DESIGN REQUIREMENTS FOR MODIFICATIONS]

JACK

Jacking and Lifting Points

Jack Storage

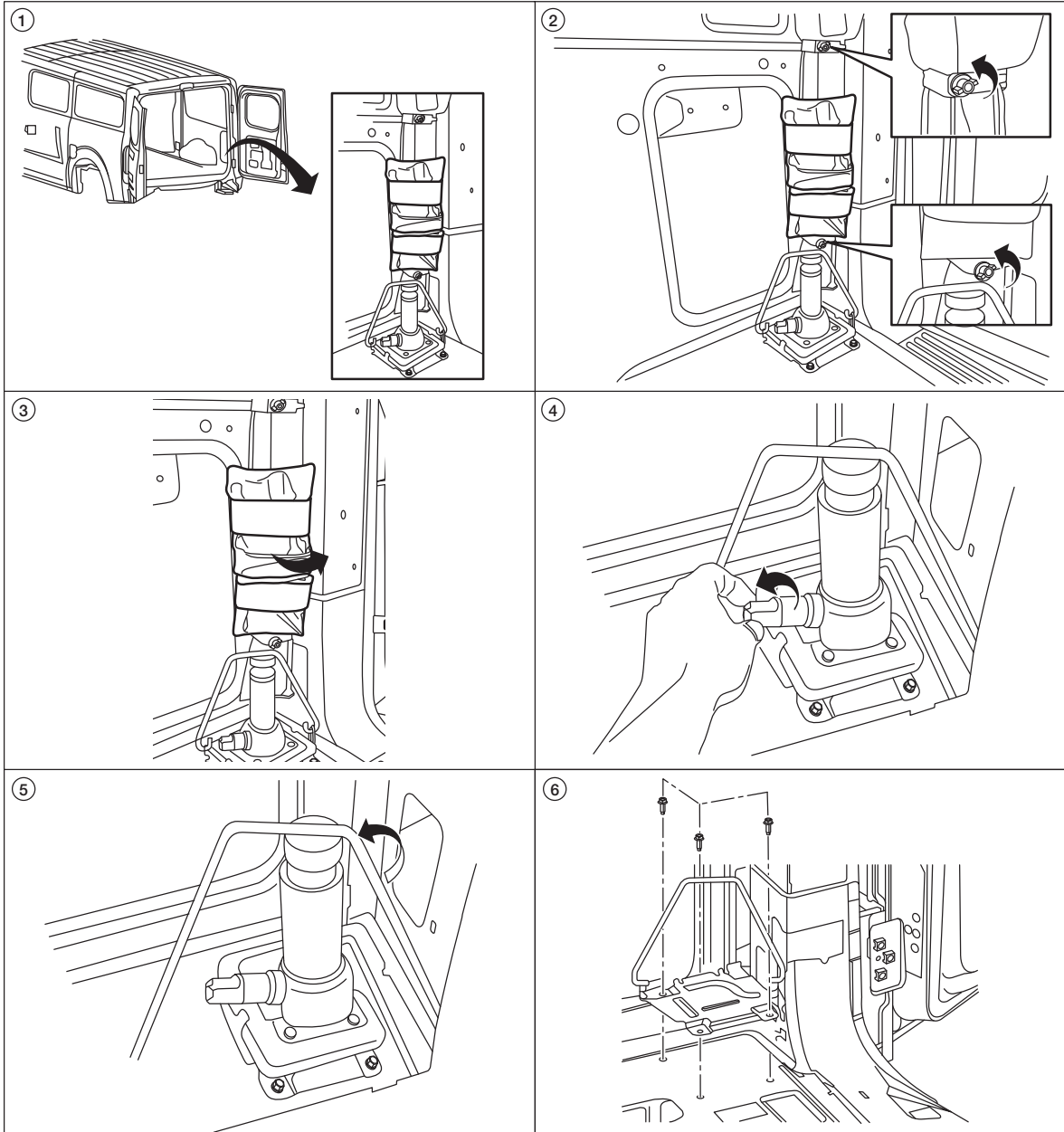

AAZIA0080ZZ

Bottle Jack Points

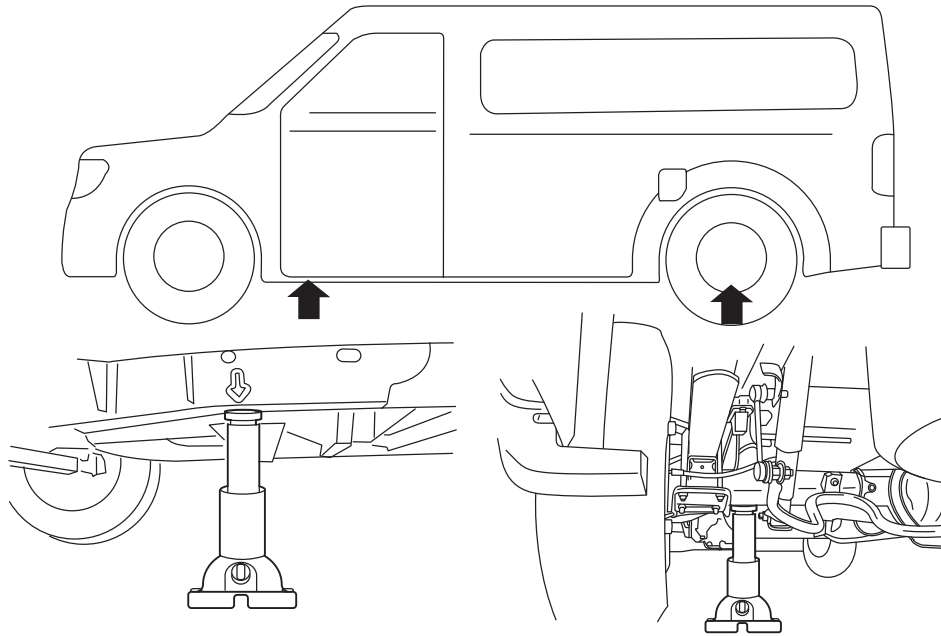

AAZIA0016ZZ

JACK

[DESIGN REQUIREMENTS FOR MODIFICATIONS]

2 Pole Lift Points

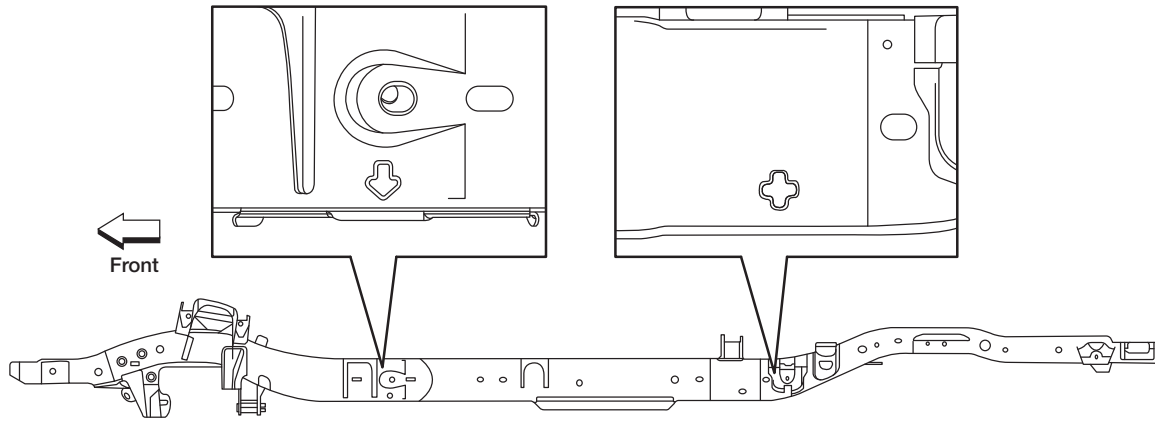

AAZIA0280GB

HIGH STRENGTH STEEL LOCATIONS

Precaution in Repairing High Strength Steel (HSS)



WARNING:

- While working, suitable work clothes, a work cap and safety shoes must be worn. To prevent burns, a long sleeve shirt and trousers must also be worn and must not be taken off under any circumstance.
- Before starting repair work, be sure to disconnect the negative terminal of the battery.
- Pay attention to ventilation and health of the operators.
- Paint and sealants may generate poisonous gases when heated by fire.



WARNING:

Do not heat, bend, or cut high strength steel or the structural integrity of the vehicle may be compromised.

High Strength Steel Locations

The grey shading in the following illustrations indicate body areas with high strength steel (HSS).

Front — Standard Roof

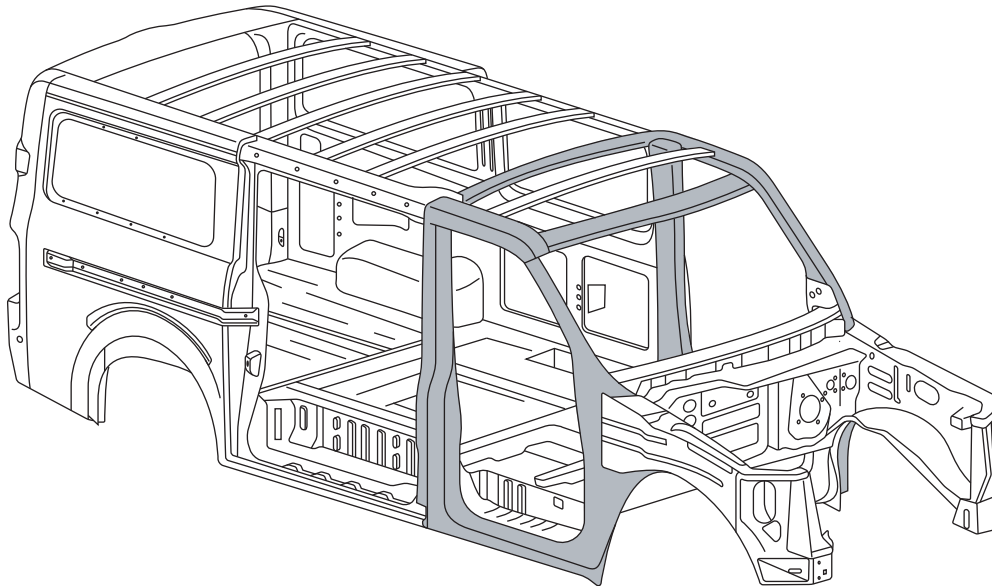

AAZIA0081ZZ

HIGH STRENGTH STEEL LOCATIONS

[DESIGN REQUIREMENTS FOR MODIFICATIONS]

Front — High Roof

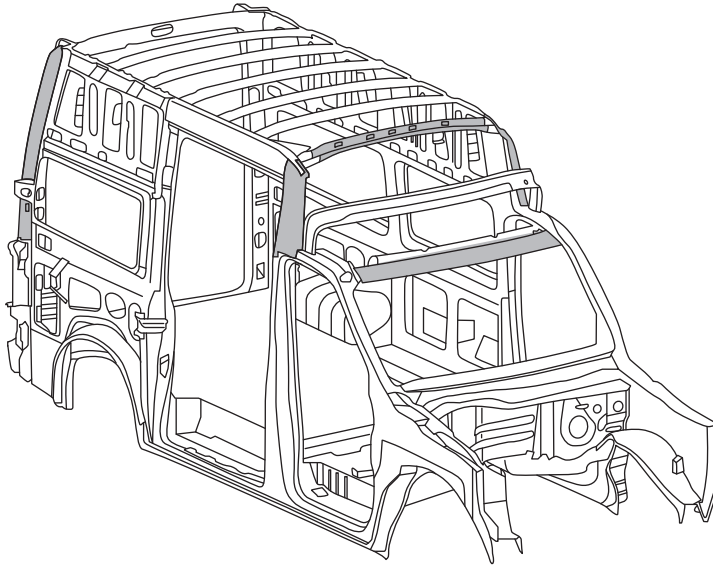

AAZIA0085ZZ

Rear — Standard Roof

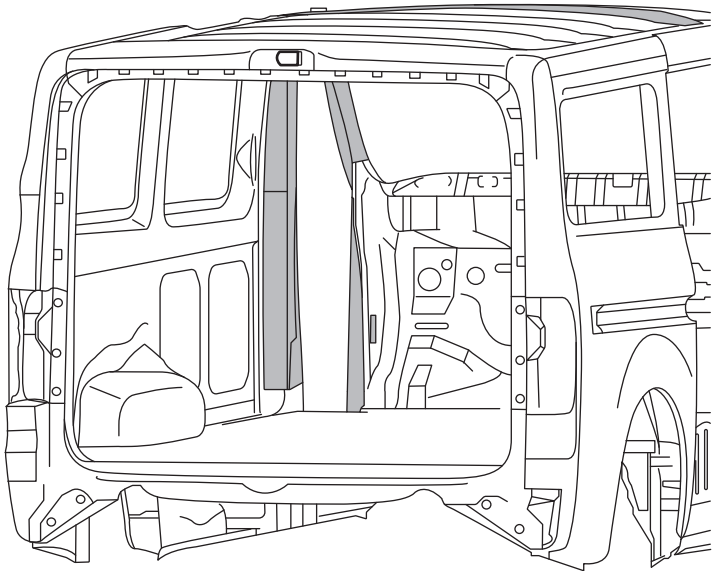

AAZIA0082ZZ

WELDING

[DESIGN REQUIREMENTS FOR MODIFICATIONS]

Rear — High Roof

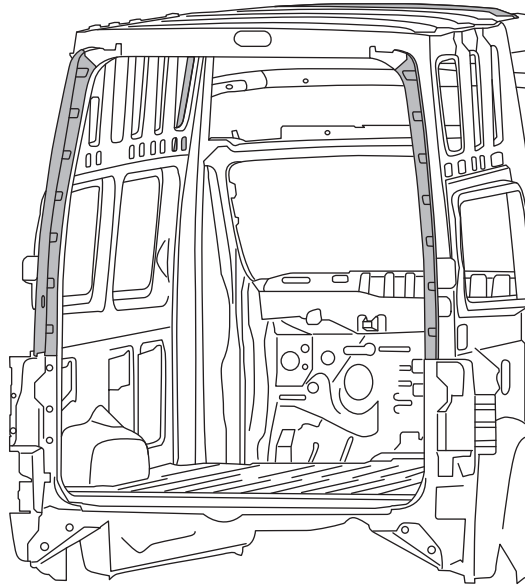

AAZIA0083ZZ

Floor

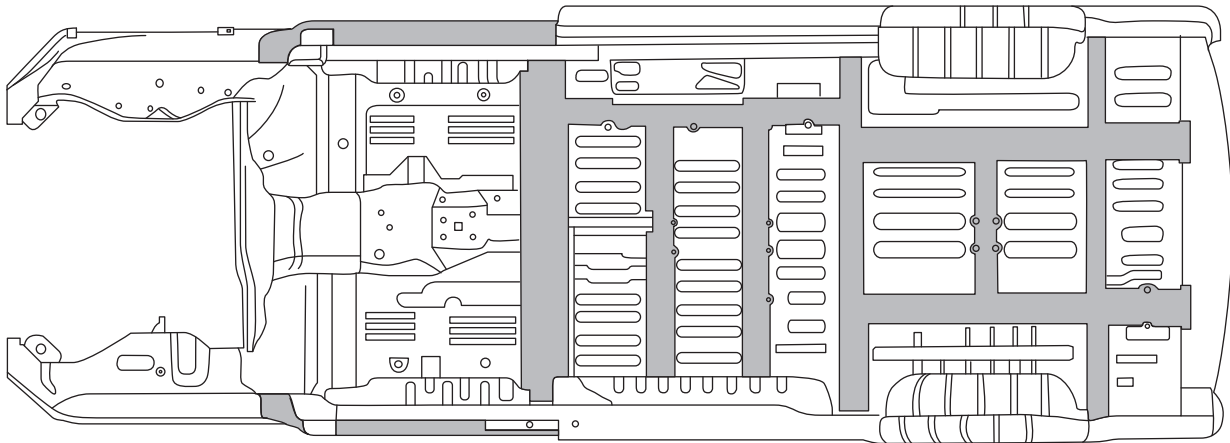

AAZIA0084ZZ

WELDING



WARNING:

Do not heat, bend, or cut high strength steel or the structural integrity of the vehicle may be compromised.

Refer to Service Manual BRM section for welding information.

VEHICLE INTERIOR

Modifications in the Vehicle Interior

General



WARNING:

The body builder, conversion company or dealer are responsible for making sure the modifications or installed equipment do not affect the safety of the vehicle, including modifications which may result in a collision, property damage, personal injury or death, such as but not limited to:

- **The modifications should not affect the operation of the control units (pedals, switches, rods, etc.) located in the area affected by the modification.**
- **The ergonomic access to the controls for the driver must not be prevented by the installation of new components.**
- **The aftermarket equipment manufacturer, second stage manufacturer, and upfitter must ensure that any modifications that have been made to the cabin still meet the legal requirements regarding the interior and exterior characteristics.**

After any modification to the body that affect the acoustic and thermal insulation, the new and/or modified insulation must meet or exceed the original specifications.

Any modifications made by the aftermarket equipment manufacturer, second stage manufacturer, and upfitter must be properly sealed to protect against corrosion.

No new holes should be drilled to allow for attaching any new components to the roof of the cabin.

Modifications in the Roof of the Cabin

When attaching equipment to the roof, make sure that the added weight does not exceed the maximum roof load limit.

All components that pass through the external sheet metal (for electric cables, telephone aerials, etc.) must be properly sealed. Only Nissan approved products should be used.

Changes to the center of gravity should not exceed the maximum authorized height. [CENTER OF GRAVITY \(pg. 33\)](#).

PAINT GENERAL INFORMATION

[DESIGN REQUIREMENTS FOR MODIFICATIONS]

PAINT GENERAL INFORMATION

The aftermarket equipment manufacturer, second stage manufacturer, and upfitter are responsible for repairing any damage to the paint incurred while modifying the vehicle.

Only Nissan specified paint should be used for these repairs. Refer to the BRM section in the Service Manual for information about the paint.

PAINT WORK — 2012 Model Year

[DESIGN REQUIREMENTS FOR MODIFICATIONS]

PAINT WORK — 2012 Model Year

Component	Trim Level	Country	Color code	A20	RAB	K23	KH3	NAB	QAK
			Description	Red	Blue	Silver	Black	Red	White
			Type	S	M	M	S	M	S
			Clear coat	t	t	t	t	t	t
Outside mirror	S	USA and Canada	Molded black						
	SV		Chromium plate						
Bumpers	S	USA and Canada	Black						
	SV		Chromium plate						
Outside handles	S	USA and Canada	Molded black						
	SV		Chromium plate						
Radiator grille	S	USA and Canada	Molded black						
	SV		Chromium plate						

M: Metallic; S: Solid; t: Primerless Diamond Coat Clear

PAINT WORK — 2013 Model Year

[DESIGN REQUIREMENTS FOR MODIFICATIONS]

PAINT WORK — 2013 Model Year

Component	Trim Level	Country	Color code	A20	RAQ	K23	KH3	NAB	QAK
			Description	Red	Blue	Silver	Black	Red	White
			Type	S	M	M	S	M	S
			Clear coat	t	t	t	t	t	t
Outside mirror	S	USA	Molded black (standard), Chromium plate (optional)						
		Canada and Mexico	Molded black						
	SV	USA	Molded black (standard), Chromium plate (optional)						
		Canada	Chromium plate						
Bumpers	S	USA, Canada and Mexico	Black						
	SV	USA and Canada	Chromium plate						
Outside handles	S	USA, Canada and Mexico	Molded black						
	SV								
Radiator grille	S	USA, Canada and Mexico	Molded black						
	SV	USA and Canada	Chromium plate						

M: Metallic; S: Solid; t: Primerless Diamond Coat Clear

PAINT WORK — 2014 Model Year

[DESIGN REQUIREMENTS FOR MODIFICATIONS]

PAINT WORK — 2014 Model Year

Component	Trim Level	Country	Color code	A20	RAQ	K23	KH3	NAB	QAK
			Description	Red	Blue	Silver	Black	Red	White
			Type	S	M	M	S	M	S
			Clear coat	t	t	t	t	t	t
Outside mirror	S	USA, Canada and Mexico	Molded black						
	SV	USA	Molded black (standard) Chromium plate (optional)						
		Canada	Chromium plate						
Bumpers	S	USA, Canada and Mexico	Black						
	SV	USA	Molded black (standard) Chromium plate (optional)						
		Canada	Chromium plate						
Outside handles	S	USA, Canada and Mexico	Molded black						
	SV	USA	Molded black (standard) Chromium plate (optional)						
		Canada	Molded Black						
Radiator grille	S	USA, Canada and Mexico	Molded black						
	SV	USA	Molded black (standard) Chromium plate (optional)						
		Canada	Chromium plate						

M: Metallic; S: Solid; t: Primerless Diamond Coat Clear

PAINT WORK — 2015 Model Year

[DESIGN REQUIREMENTS FOR MODIFICATIONS]

PAINT WORK — 2015 Model Year

Exterior Body Color	Color code	A20	RBG	K23	KH3	NAB	QAK
	Description	Red	Blue	Silver	Black	Red	White
	Type	S	M	M	S	M	S
	Clear coat	t	t	t	t	t	t

Component	Country	Trim Level	Model	Color
Outside mirror	USA	S, SV	1500, 2500 (V6)	Molded black
		S, SV	2500 (V8)	Chromium plate
		SL	2500	
		S, SV, SL	3500	
	Canada	S	1500, 2500, 3500	Molded black
		SV	2500 (V6)	Chromium plate
		SV	2500, 3500 (V8)	
	Mexico	S	2500	Molded black
	Bumpers	USA	S, SV	1500, 2500, 3500
SL			2500, 3500	Chromium plate
Canada		S	1500, 2500, 3500	Black
		SV	2500, 3500	Chromium plate
Mexico		S	2500	Black
Outside handles		USA	S, SV	1500, 2500, 3500
	SL		2500, 3500	Chromium plate (Rear door - Molded Black)
	Canada	S	1500	Molded Black
		S, SV	2500, 3500	Chromium plate (Rear door - Molded Black)
	Mexico	S	2500	Molded Black

PAINT WORK — 2015 Model Year

[DESIGN REQUIREMENTS FOR MODIFICATIONS]

Component	Country	Trim Level	Model	Color
Radiator grille	USA	S, SV	1500, 2500, 3500	Molded black
		SL	2500, 3500	Chromium plate
	Canada	S	1500, 2500, 3500	Molded black
		SV	2500, 3500	Chromium plate
	Mexico	S	2500	Molded black

M: Metallic; S: Solid; t: Primerless Diamond Coat Clear

PAINT WORK — 2016-2020 Model Years

[DESIGN REQUIREMENTS FOR MODIFICATIONS]

PAINT WORK — 2016-2020 Model Years

Exterior Body Color	Color code	RBG *	K23	KH3 *	NAH *	QAK
	Description	Blue	Silver	Black	Red	White
	Type	M	M	S	M	S
	Clear coat	t	t	t	t	t

* Not available in Mexico market

Component	Country	Trim Level	Model	Color
Outside mirror	USA	S, SV	1500, 2500 (V6)	Molded black
		S, SV	2500 (V8)	Chromium plate
		SL	2500	
		S, SV, SL	3500	
	Canada	S	1500, 2500, 3500	Molded black
		SV	2500 (V6)	Chromium plate
		SV	2500, 3500 (V8)	
	Mexico	S	2500	Molded black
	Bumpers	USA	S, SV	1500, 2500, 3500
SL			2500, 3500	Chromium plate
Canada		S	1500, 2500, 3500	Black
		SV	2500, 3500	Chromium plate
Mexico		S	2500	Black
Outside handles	USA	S, SV	1500, 2500, 3500	Molded black
		SL	2500, 3500	Chromium plate (Rear door - Molded Black)
	Canada	S	1500	Molded Black
		S, SV	2500, 3500	Chromium plate (Rear door - Molded Black)
	Mexico	S	2500	Molded Black

PAINT WORK — 2016-2020 Model Years
[DESIGN REQUIREMENTS FOR MODIFICATIONS]

Component	Country	Trim Level	Model	Color
Radiator grille	USA	S, SV	1500, 2500, 3500	Molded black
		SL	2500, 3500	Chromium plate
	Canada	S	1500, 2500, 3500	Molded black
		SV	2500, 3500	Chromium plate
	Mexico	S	2500	Molded black

M: Metallic; S: Solid; t: Primerless Diamond Coat Clear

PAINT WORK — Starting with 2021 Model Year

[DESIGN REQUIREMENTS FOR MODIFICATIONS]

PAINT WORK — Starting with 2021 Model Year

Exterior Body Color	Color code	RBG *	K23	KH3 *	NAH *	QAK
	Description	Blue	Silver	Black	Red	White
	Type	2PM	2M	2S	2PM	2S
	Hard clear coat	x	x	x	x	x

* Not available in Mexico market

Component	Country	Trim Level	Model	Color
Door mirrors	USA	S, SV	1500, 2500 (V6)	Molded black
		S, SV	2500 (V8)	Chromium plate
		SL	2500	
		S, SV, SL	3500	
	Canada	S	1500, 2500, 3500	Molded black
		SV	2500 (V6)	Chromium plate
		SV	2500, 3500 (V8)	
	Mexico	S	2500	Molded black
	Bumpers	USA	S, SV	1500, 2500, 3500
SL			2500, 3500	Chromium plate
Canada		S	1500, 2500, 3500	Black
		SV	2500, 3500	Chromium plate
Mexico		S	2500	Black
Outside door handles	USA	S, SV	1500, 2500, 3500	Molded black
		SL	2500, 3500	Chromium plate
	Canada	S	1500	Molded Black
		S, SV	2500, 3500	Chromium plate (Rear door - Molded Black)
	Mexico	S	2500	Molded Black

PAINT WORK — Starting with 2021 Model Year**[DESIGN REQUIREMENTS FOR MODIFICATIONS]**

Component	Country	Trim Level	Model	Color
Front grille	USA	S, SV	1500, 2500, 3500	Molded black
		SL	2500, 3500	Chromium plate
	Canada	S	1500, 2500, 3500	Molded black
		SV	2500, 3500	Chromium plate
	Mexico	S	2500	Molded black

2M: 2 coat metallic; 2S: 2 coat solid; 2PM: 2 coat pearl metallic

ADHESIVE INFORMATION

[DESIGN REQUIREMENTS FOR MODIFICATIONS]

ADHESIVE INFORMATION

MSDS Information

Contact the product supplier for the latest MSDS (Material Safety Data Sheet) information.

Product Name	Code/Number	Supplier/Emergency Phone Numbers
ED- 6465 CATIONIC PASTE	E6394	PPG Refinish www.ppg.com Technical information: 1-800-647-6050
OPP4648 BLUE PRIMER	OPP4648	Safety information: USA 1-412-434-5415 Canada 1-514 645-1320 Mexico 01-800-00-21-400
Chemfos 700RCAN	CF700RCANI (0820-TO)	China 0532-83889090 Product safety/MSDS information: 412-492-5555
826916PM (sealer)	B129U	EFTEC North America, L.L.C. www.eftec.com
827052PM (coating)	EF6287	24 hour emergency 1-888-853-1758
813598PM (PVC plastisol)	8045	Chemtrec emergency 1-800-424-9300
TEROPHON 23	1284663	Henkel Corporation www.henkel.com
Terotex PTA 165-N2	RS00233446 or 923315	USA 1-248-583-9300 Chemtrec emergency 1-800-424-9300
Betamate (structural adhesive)	1484LTC	Dow Chemical Co. www.dow.com 24 hour emergency 1-989-636-4400 Customer information 1-800-258-2436
Uniseal (Spot weld sealing material)	168.8	Uniseal Corp. www.uniseal.com 1-800-443-6297 1-812-463-5230
Sikaflex-221 (adhesive sealant)	221	Sika Corporation. http://usa.sika.com/en/group.html Information: 1-800-933-7452 Chemtrec emergency 1-800-424-9300

REPLACING BOLTS

[DESIGN REQUIREMENTS FOR MODIFICATIONS]

REPLACING BOLTS

Tightening Torque Table

Grade	Bolt size	Bolt diameter * mm	Pitch mm	Tightening torque (Without lubricant)							
				Hexagon head bolt				Hexagon flange bolt			
				N·m	kg·m	ft·lb	in·lb	N·m	kg·m	ft·lb	in·lb
4T	M6	6.0	1.0	5.5	0.56	4	49	7	0.71	5	62
	M8	8.0	1.25	13.5	1.4	10	—	17	1.7	13	—
			1.0	13.5	1.4	10	—	17	1.7	13	—
	M10	10.0	1.5	28	2.9	21	—	35	3.6	26	—
			1.25	28	2.9	21	—	35	3.6	26	—
	M12	12.0	1.75	45	4.6	33	—	55	5.6	41	—
1.25			45	4.6	33	—	65	6.6	48	—	
M14	14.0	1.5	80	8.2	59	—	100	10	74	—	
7T	M6	6.0	1.0	9	0.92	7	80	11	1.1	8	97
	M8	8.0	1.25	22	2.2	16	—	28	2.9	21	—
			1.0	22	2.2	16	—	28	2.9	21	—
	M10	10.0	1.5	45	4.6	33	—	55	5.6	41	—
			1.25	45	4.6	33	—	55	5.6	41	—
	M12	12.0	1.75	80	8.2	59	—	100	10	74	—
1.25			80	8.2	59	—	100	10	74	—	
M14	14.0	1.5	130	13	96	—	170	17	125	—	
9T	M6	6.0	1.0	11	1.1	8	—	13.5	1.4	10	—
	M8	8.0	1.25	28	2.9	21	—	35	3.6	26	—
			1.0	28	2.9	21	—	35	3.6	26	—
	M10	10.0	1.5	55	5.6	41	—	80	8.2	59	—
			1.25	55	5.6	41	—	80	8.2	59	—
	M12	12.0	1.75	100	10	74	—	130	13	96	—
1.25			100	10	74	—	130	13	96	—	
M14	14.0	1.5	170	17	125	—	210	21	155	—	

* Nominal diameter

1. Special parts are excluded.
2. This standard is applicable to bolts having the following marks embossed on the bolt head.

Grade	Mark
4T 4
7T 7
9T 9

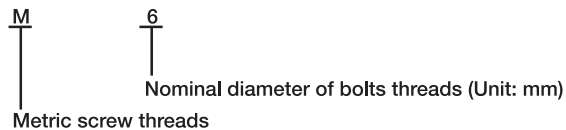

MG1044A

ADD ON EQUIPMENT

ANTI-CORROSION PROTECTION

**CAUTION:**

When any vehicle modifications are performed, check for proper clearance between existing components or newly installed components. Failure to do so may result in vehicle or component damage.

**CAUTION:**

Failure to refinish bare metal will result in corrosion.

The basic steps to refinish bare metal are as follows:

1. Prep the metal surface(s) as follows:
 - A. Remove burrs from the edges with a file or sandpaper.
 - B. Thoroughly clean the metal with solvent and allow to completely dry.
 - C. Apply self-etching primer to all bare metal.
 - D. Allow primer to properly dry.
2. Apply base coat paint and allow to properly dry.
3. Apply clear coat and allow to properly dry.
4. To help prevent internal corrosion, apply cavity wax into any applicable areas.

SHELVING AND BULKHEAD INSTALLATION

Bulkhead

The bulkhead should be attached to the Nissan supplied weld nuts in the roof crossmember and the floor. No new attachment points should be added. Loading should be distributed evenly utilizing as many mounting points as possible.

Standard Roof

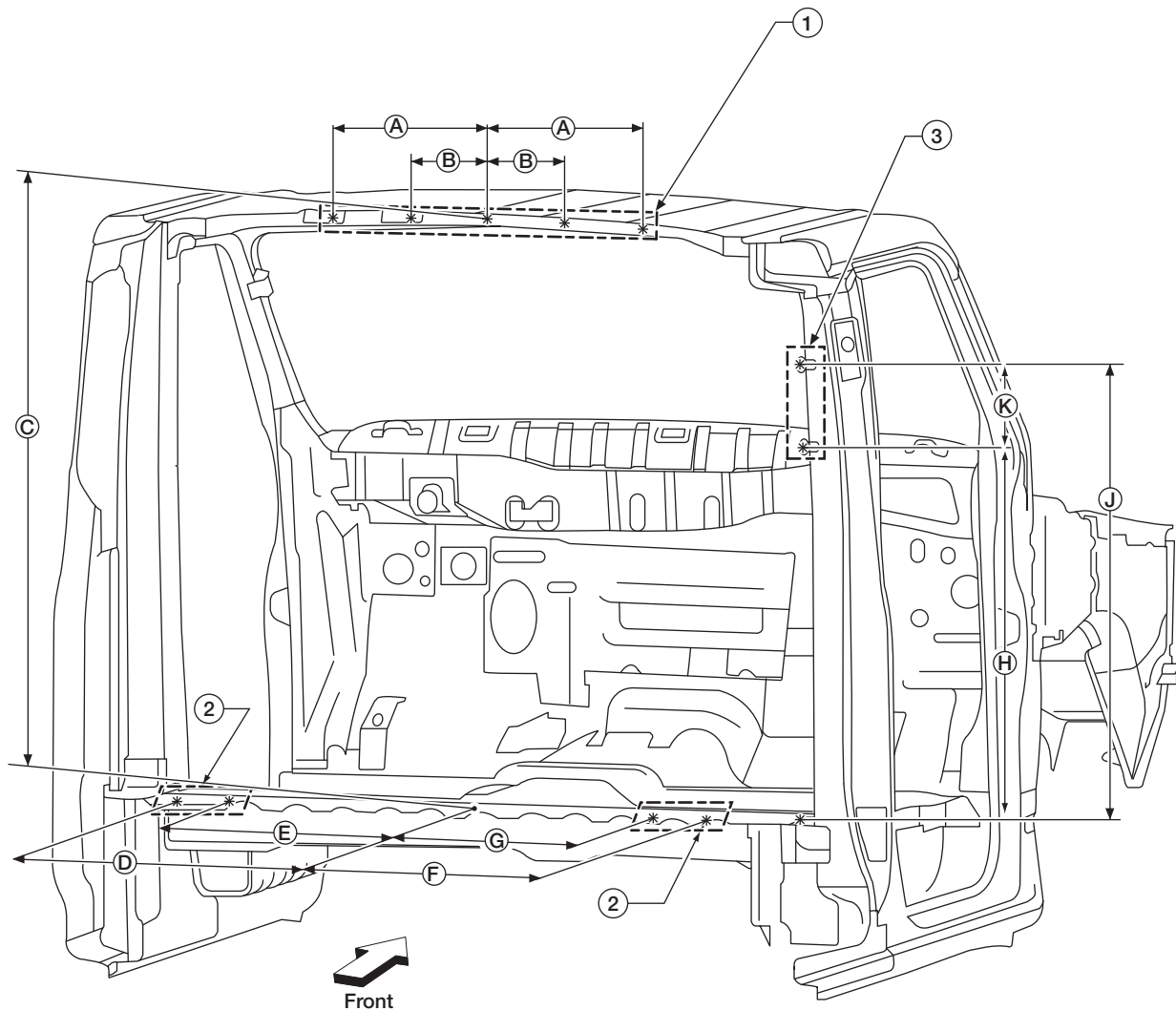

AAZIA0232GB

SHELVING AND BULKHEAD INSTALLATION

[ADD ON EQUIPMENT]

* Weld nut locations for bulkhead installation; All bolts are M8 x 1.25

1. Mounting point loading not to exceed 5 kg (11 lbs) per point. Total loading across these 5 mounting points not to exceed 30 kg (66 lbs).

2. Mounting point loading not to exceed 10 kg (22 lbs) per point.

3. Mounting point loading not to exceed 5 kg (11 lbs) per point. Total loading across these 2 mounting points not to exceed 10 kg (22 lbs).

A. 400 mm (15.7 in)

B. 160 mm (6.3 in)

C. 1,379 mm (54.3 in)

D. 728 mm (28.7 in)

E. 601 mm (23.7 in)

F. 587 mm (23.1 in)

G. 440 mm (17.3 in)

H. 873 mm (34.4 in)

J. 1,063 mm (41.9 in)

K. 190 mm (7.5 in)

High Roof

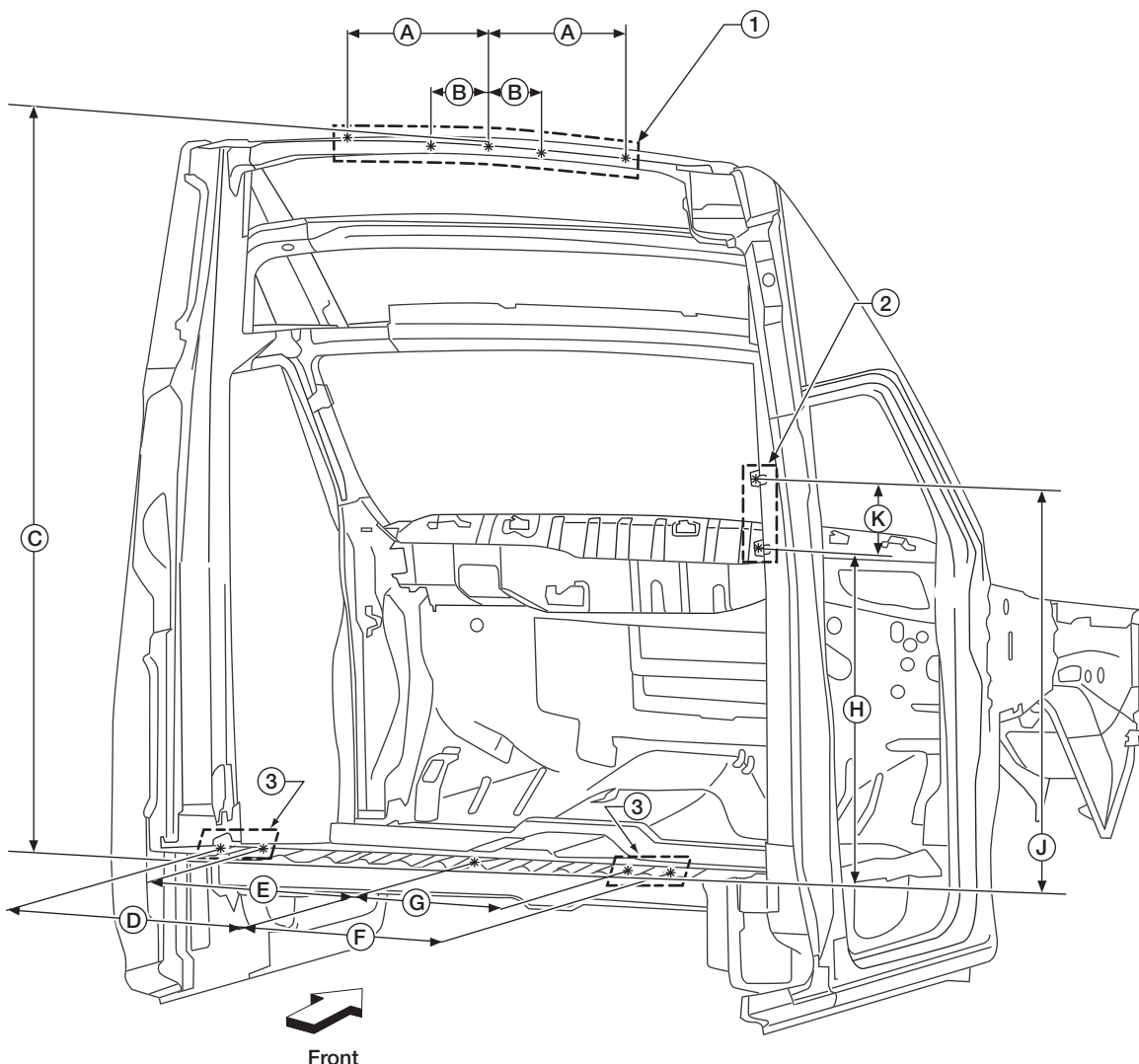

AAZIA0284GB

* Weld nut locations for bulkhead installation; All bolts are M8 x 1.25

1. Mounting point loading not to exceed 5 kg (11 lbs) per point. Total loading across these 5 mounting points not to exceed 30 kg (66 lbs).

2. Mounting point loading not to exceed 5 kg (11 lbs) per point. Total loading across these 2 mounting points not to exceed 10 kg (22 lbs).

3. Mounting point loading not to exceed 10 kg (22 lbs) per point.

A. 400 mm (15.7 in)

B. 160 mm (6.3 in)

C. 1,916 mm (75.4 in)

D. 728 mm (28.7 in)

E. 601 mm (23.7 in)

F. 587 mm (23.1 in)

G. 440 mm (17.3 in)

H. 873 mm (34.4 in)

J. 1,063 mm (41.9 in)

K. 190 mm (7.5 in)

Shelving

The shelving should be attached to the Nissan supplied weld nuts built into the body side inner panels and the floor. No new attachment points should be added. The shelving weld nuts are common between the standard and the high roof vehicles, the high roof is shown. Loading should be distributed evenly utilizing as many mounting points as possible.

Brackets [Kit part number 999T7 HX000]

NOTE:

For high roof models, these brackets are available from a NISSAN dealer. For Mexico high roof models, these brackets are standard equipment installed at the factory.

The brackets are required for shelving installation on high roof vans only.

Without Hardboard Trim

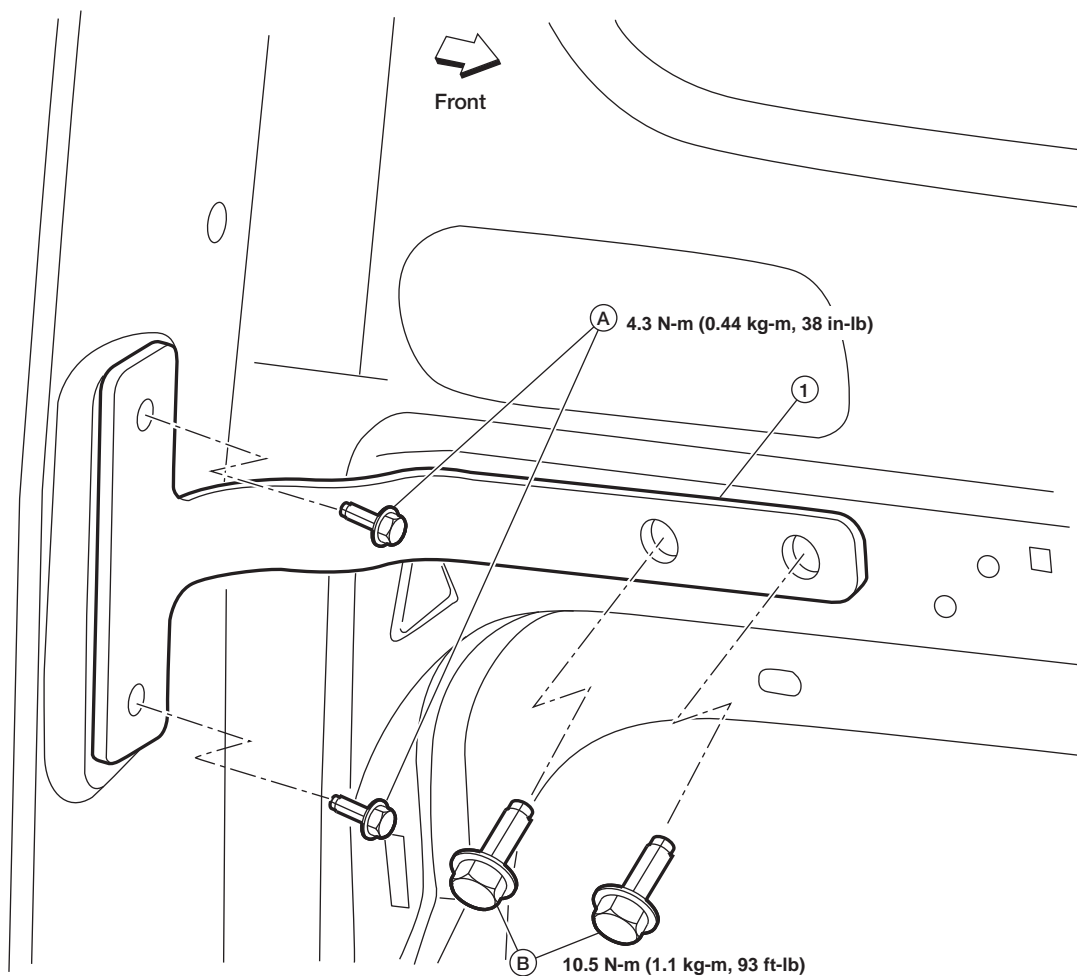

AAZIA0393GB

1. D-pillar bracket

A. M6 x 16 mm bolts

B. M8 x 16 mm bolts

SHELVING AND BULKHEAD INSTALLATION

[ADD ON EQUIPMENT]

With Hardboard Trim

The installation of the brackets on vehicles equipped with hardboard trim will require the use of washers as spacers and the removal of the rear-most trim clip.

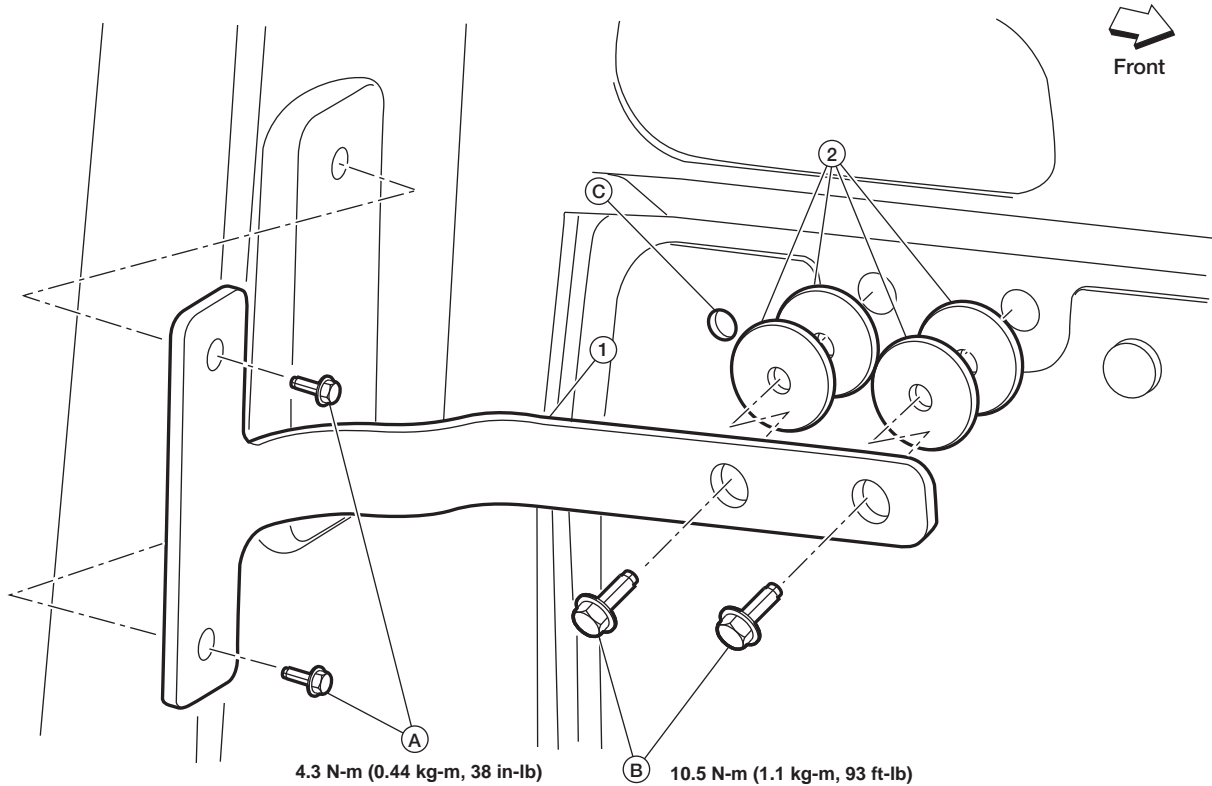

1. D-pillar bracket
B. M8 x 20 mm bolts

2. Fender washers (shims)
C. Trim clip hole

A. M6 x 16 mm bolts

AAZIA0394GB

SHELVING AND BULKHEAD INSTALLATION

[ADD ON EQUIPMENT]

RH Body Side and D-pillar Inner

RH body side inner as viewed from inside the vehicle. Loading should be distributed evenly, utilizing as many mounting points as possible.

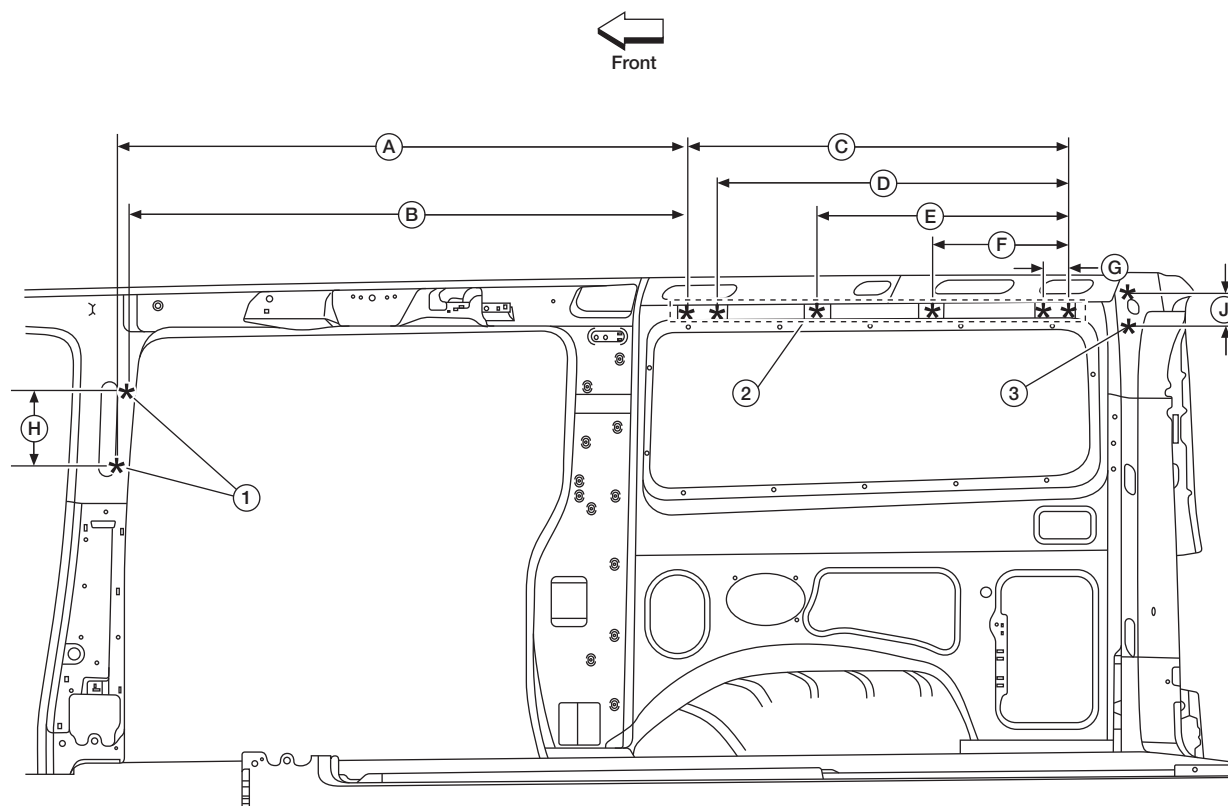

AAZIA0004ZZ

* Weld nut locations; All bolts are M8 x 1.25.

1. Mounting point loading not to exceed 5 kg (11 lbs) per point. Total loading across these 2 mounting points not to exceed 10 kg (22 lbs).

2. Mounting point loading not to exceed 10 kg (22 lbs) per point. Maximum loading across these 8 mounting points not to exceed 60 kg (130 lbs).

3. Mounting point loading not to exceed 10 kg (22 lbs) per point. Total loading across these 2 mounting points not to exceed 20 kg (44 lbs).

A. 1,546 mm (60.9 in)

B. 1,537 mm (60.5 in)

C. 1,056 mm (41.6 in)

D. 1,006 mm (39.6 in)

E. 679 mm (26.7 in)

F. 368 mm (14.5 in)

G. 50 mm (2 in)

H. 190 mm (7.5 in)

J. 63.5 mm (2.5 in)

SHELVING AND BULKHEAD INSTALLATION

[ADD ON EQUIPMENT]

LH Body Side and D-pillar Inner

LH body side inner as viewed from inside the vehicle. Loading should be distributed evenly, utilizing as many mounting points as possible.

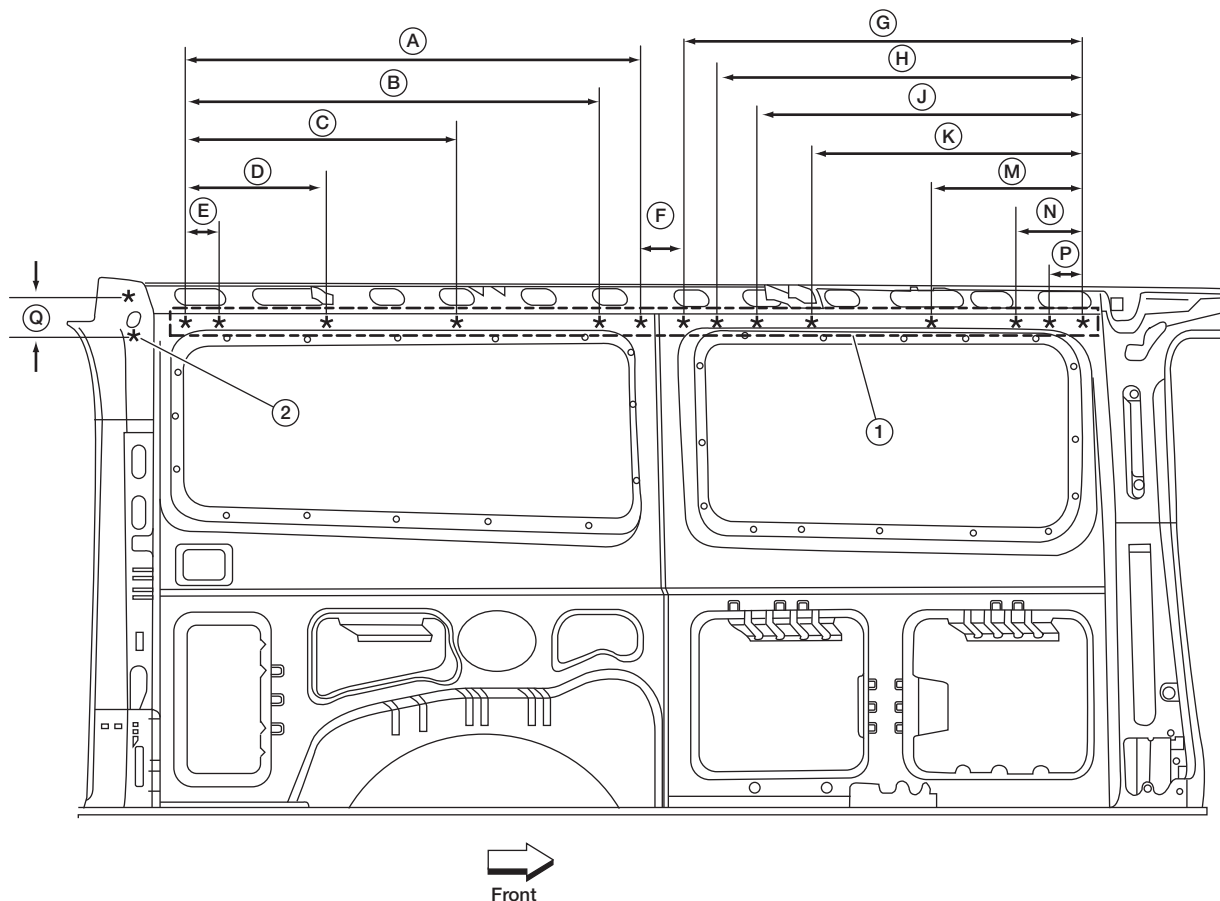

AAZIA0064ZZ

* Weld nut locations; All bolts are M8 x 1.25

1. Mounting point loading not to exceed 10 kg (22 lbs) per point. Total loading across these 14 mounting points not to exceed 120 kg (260 lbs).

2. Mounting point loading not to exceed 10 kg (22 lbs) per point. Total loading across these 2 mounting points not to exceed 20 kg (44 lbs).

A. 1,183 mm (46.6 in)

B. 1,133 mm (44.6 in)

C. 772 mm (30.4 in)

D. 411 mm (16.2 in)

E. 50 mm (2 in)

F. 219 mm (8.6 in)

G. 1,057 mm (41.6 in)

H. 1,007 mm (39.6 in)

J. 917 mm (36.1 in)

K. 694 mm (27.3 in)

M. 403 mm (15.9 in)

N. 140 mm (5.5 in)

P. 50 mm (2 in)

Q. 63.5 mm (2.5 in)

SHELVING AND BULKHEAD INSTALLATION

[ADD ON EQUIPMENT]

Floor

The shelves bolt to the same locations on the floor for both high and standard roof vehicles. Loading should be distributed evenly utilizing as many mounting points as possible.

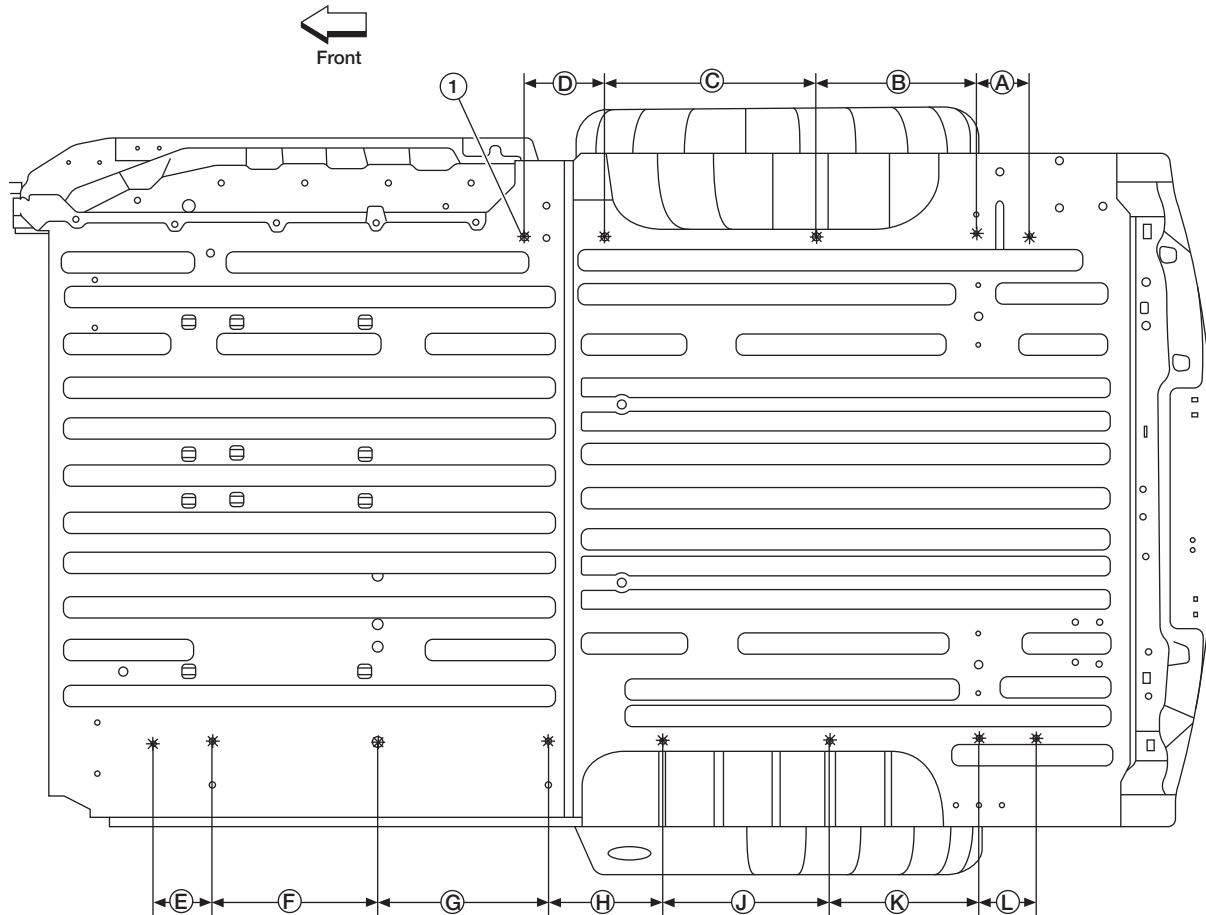

AAZIA0063ZZ

* Weld nut locations for shelving installation; All bolts are M8 x 1.25

1. Mounting point loading not to exceed 30 kg (66 lbs).

A. 139 mm (5.5 in)

B. 419 mm (16.5 in)

C. 559 mm (22.0 in)

D. 157 mm (6.2 in)

E. 162 mm (6.4 in)

F. 435 mm (17.1 in)

G. 451 mm (17.8 in)

H. 300 mm (11.8 in)

J. 441 mm (17.4 in)

K. 393 mm (15.5 in)

L. 150 mm (5.9 in)

Interior Roof Bow Mounting Points

Loading should be distributed evenly, utilizing as many mounting points as possible.

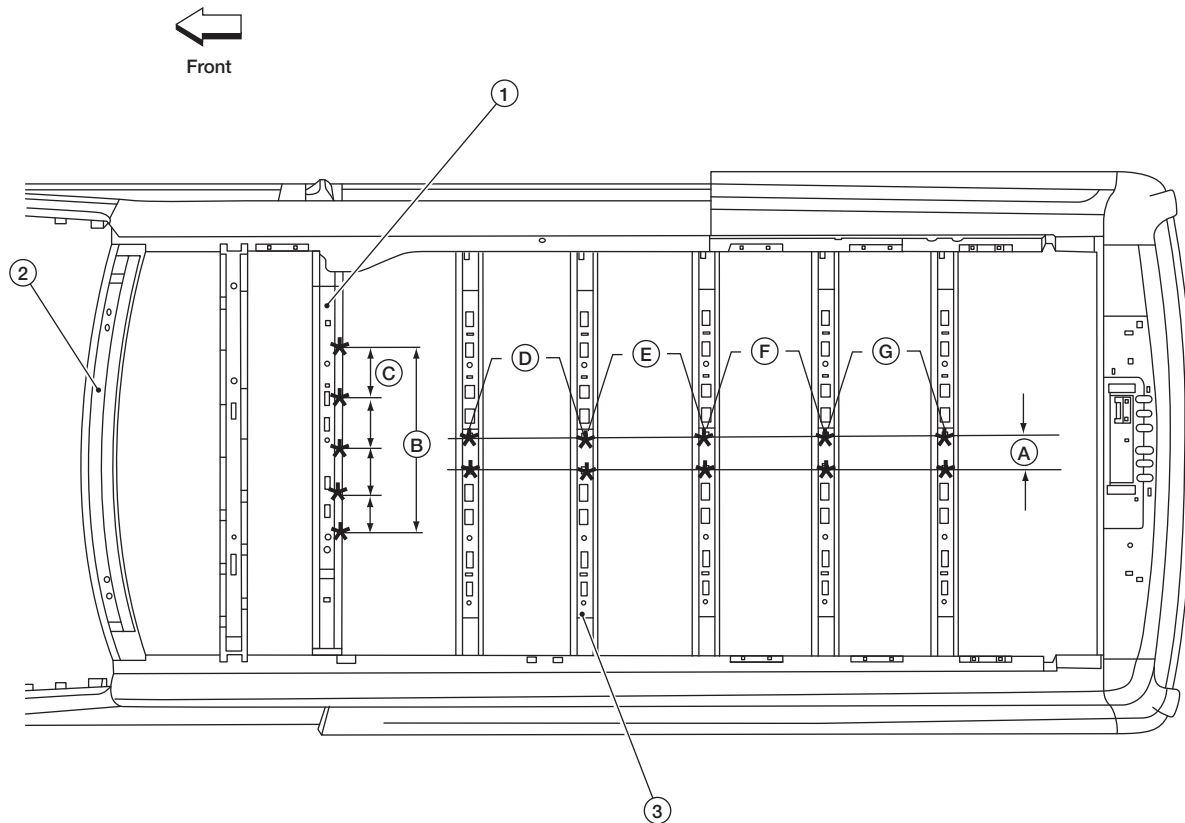

AAZIA0027ZZ

* Weld nut locations

1. Bulkhead roof bow (Mounting point loading not to exceed 5 kg (11 lbs) per point. Total loading across these 5 mounting points not to exceed 30 kg (66 lbs). These 5 weld nuts accept M8 x 1.25 bolts.

2. Windshield header

3. Roof bow (Mounting point loading not to exceed 4 kg (8.8 lbs) per point. Total loading across these 10 mounting points not to exceed 30 kg (66 lbs). These 10 weld nuts accept M6 x 1.0 bolts.

A. 130 mm (5.1 in)

B. 800 mm (31.5 in)

C. 160 mm (6.3 in)

D. 410 mm (16.14 in)

E. 433.4 mm (17.06 in)

F. 431.4 mm (16.98 in)

G. 425 mm (16.73 in)

ROOF RACKS

**WARNING:**

- Drive extra carefully when the vehicle is loaded at or near the cargo carrying capacity, especially if the significant portion of that load is carried on the roof rack.
- Heavy loading of the roof rack has the potential to affect the vehicle stability and handling during sudden or abnormal handling maneuvers.
- Roof rack load should be evenly distributed.
- Do not exceed maximum roof rack load weight capacity.
- Properly secure all cargo with ropes or straps to help prevent it from sliding or shifting. In a sudden stop or collision, unsecured cargo could cause personal injury.
- To avoid personal injury, use care when placing or removing items from the roof rack. If you cannot comfortably lift the items onto the roof rack from the ground, use a ladder or stool.

**CAUTION:**

Do not load more than 226.7 kg (500 lbs) utilizing all 5 pairs of roof rack mounting brackets on the standard roof van and not more than 136 kg (300 lbs) utilizing 4 pairs of roof rack mounting brackets on the high roof van. The maximum load per pair of roof rack mounting brackets is 45 kg (100 lbs).

Standard Roof



CAUTION:

A minimum of 5.0 mm (0.2 in) of clearance is required between the bottom of the bolts and the surface of the roof to prevent damage to the paint or metal.

The satellite radio antenna (if equipped) is located on the roof. Do not cover the module; it may affect the reception of the device.

The factory installed brackets are the only Nissan approved attachment points for the installation of a roof rack. Use J-nuts and bolts for attaching the roof racks to the brackets.

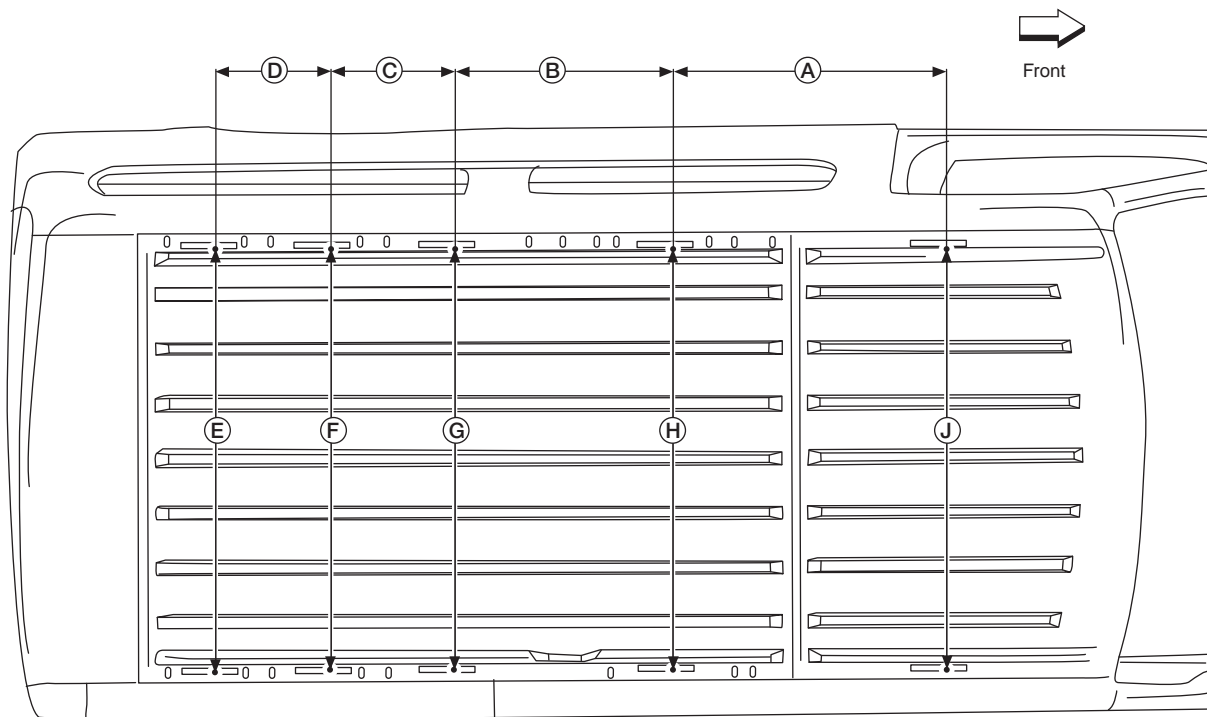

AAZIA0050ZZ

A. 938 mm (36.9 in)
D. 390 mm (15.4 in)
G. 1,474 mm (58 in)

B. 760 mm (29.9 in)
E. 1,474 mm (58 in)
H. 1,474 mm (58 in)

C. 430 mm (16.9 in)
F. 1,474 mm (58 in)
J. 1,474 mm (58 in)

High Roof



CAUTION:

A minimum of 5.0 mm (0.2 in) of clearance is required between the bottom of the bolts and the surface of the roof to prevent damage to the paint or metal.

The satellite radio antenna (if equipped) is located on the roof. Do not cover the module; it may affect the reception of the device.

The factory installed brackets are the only Nissan approved attachment points for the installation of a roof rack. Use J-nuts and bolts for attaching the roof racks to the brackets.

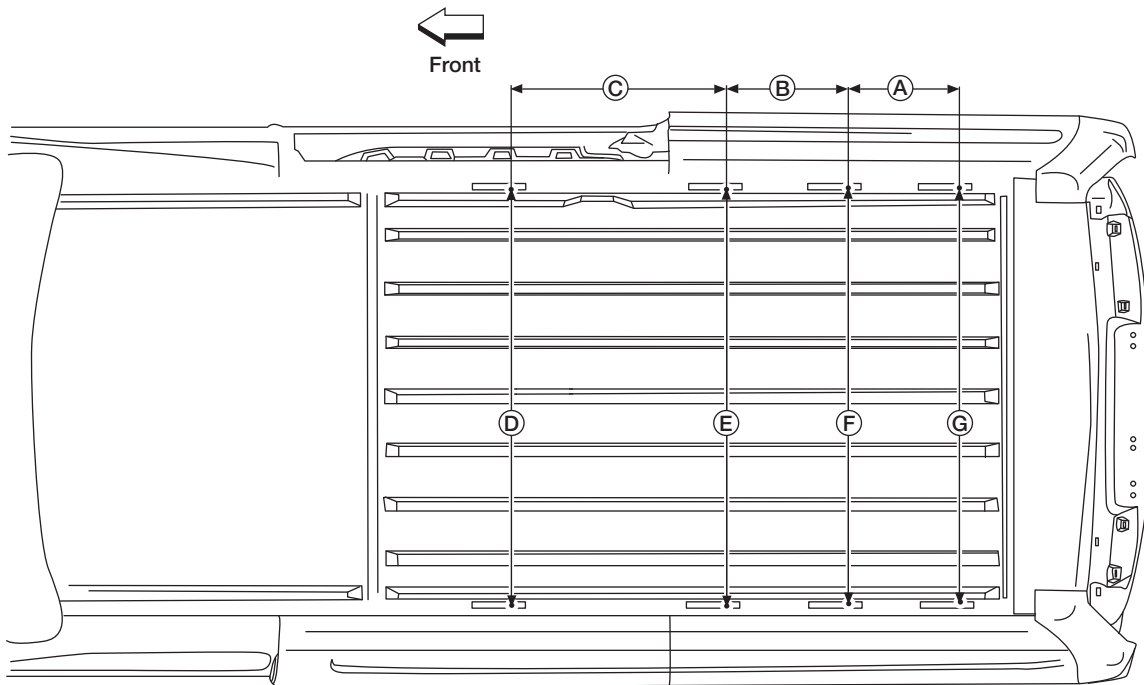

A. 390 mm (15.4 in)
 D. 1,473 mm (58.0 in)
 G. 1,473 mm (58.0 in)

B. 430 mm (16.9 in)
 E. 1,473 mm (58.0 in)

C. 760 mm (29.9 in)
 F. 1,473 mm (58.0 in)

AAZIA0112ZZ

SPECIFICATIONS

RECOMMENDED FLUIDS AND LUBRICANTS — USA AND CANADA

NOTE:

Refer to Service Manual for detailed service procedures.

VQ40DE (4.0L) Engine Equipped Models

Fluid Type		Capacity (Approximate)			Recommended Fluids/ Lubricants
		Metric Measure	US Measure	Imperial Measure	
Fuel		105.8 liters	28 gallons	23¼ gallons	Unleaded gasoline with an octane rating of at least 87 AKI (RON 91) * 1
Engine oil Drain and refill	With oil filter change	5.1 liters	5¾ quarts	4½ quarts	<ul style="list-style-type: none"> Genuine "NISSAN Motor Oil Ester 5W-30 SN" (or equivalent) is recommended If the above motor oil (or engine oil) is not available, a synthetic SAE 5W-30 GF-5 SN motor oil (or engine oil) may be used. Damage caused by the use of motor oil (or engine oil) other than as recommended is not covered under NISSAN's New Vehicle Limited Warranty. For additional information, refer to "Engine oil recommendation"
	Without oil filter change	4.8 liters	5⅛ quarts	4¼ quarts	
Engine coolant	(With reservoir at MAX level)	12.7 liters	13¾ quarts	11 1/8 quarts	Pre-diluted Genuine NISSAN Long Life Antifreeze/Coolant (blue) or equivalent * 2
Automatic transmission fluid (ATF)		10.6 liters	11¼ quarts	9¾ quarts	<ul style="list-style-type: none"> Genuine NISSAN Matic S ATF NISSAN recommends using Genuine NISSAN Matic S ATF in NISSAN automatic transmissions. If Genuine NISSAN Matic S ATF is not available, Genuine NISSAN Matic J ATF may also be used. Do not mix with other fluids. Using fluids that are not equivalent to Genuine NISSAN Matic S ATF or Genuine NISSAN Matic J ATF may damage the automatic transmission. Damage caused by the use of fluids other than as recommended is not covered under the NISSAN's New Vehicle Limited Warranty.

RECOMMENDED FLUIDS AND LUBRICANTS — USA AND CANADA

[SPECIFICATIONS]

Fluid Type	Capacity (Approximate)			Recommended Fluids/ Lubricants
	Metric Measure	US Measure	Imperial Measure	
Rear differential gear oil	2.6 liters	5 1/2 pints	4 5/8 pints	Genuine NISSAN Differential Oil Hypoid Super-S GL-5 synthetic 75W-90 or equivalent *3
Power steering fluid (PSF)	1.4 liters	3 pints	2½ pints	Genuine NISSAN PSF II or equivalent *4
Brake fluid	—	—	—	Genuine NISSAN Super Heavy Duty Brake Fluid *5 or equivalent DOT 3 (US FMVSS No. 116)
Multi-purpose grease	—	—	—	NLGI No.2 (lithium soap base)
Windshield washer fluid	4.5 liters	4 ¾ quarts	4 quarts	Genuine NISSAN Windshield Washer Concentrate Cleaner & Antifreeze or equivalent
Air conditioning system refrigerant	850 ±50 grams	1.87 pounds (±0.11 lb)	1.87 pounds (±0.11 lb)	HFC-134a (R-134a) *6
Air conditioning system oil	180 milliliters	6.1 ounces	6.3 ounces	A/C System Oil Type S (DH-PS) *6

***1:** For additional information, refer to [Precaution for Fuel \(pg. 340\)](#).

***2:** For additional information, refer to [Engine Coolant Recommendation \(pg. 341\)](#).

***3:** See a NISSAN dealer for service for synthetic oil.

***4:** DEXRON™ VI type ATF may also be used.

***5:** Available in mainland U.S.A. through a NISSAN dealer.

***6:** For additional information, see "Air conditioner specification label" on the underside of the hood.

RECOMMENDED FLUIDS AND LUBRICANTS – USA AND CANADA

[SPECIFICATIONS]

VK56DE (5.6L) Engine Equipped Models (2012 - 2016 Model Years)

Fluid Type		Capacity (Approximate)			Recommended Fluids/ Lubricants
		Metric Measure	US Measure	Imperial Measure	
Fuel		105.8 liters	28 gallons	23¼ gallons	Unleaded gasoline with an octane rating of at least 87 AKI (RON 91) *1
Engine oil Drain and refill	With oil filter change	6.5 liters	6⅞ quarts	5¾ quarts	Genuine NISSAN engine oil or equivalent Engine oil with API Certification Mark *2 , Viscosity SAE 5W-30 *3
	Without oil filter change	6.2 liters	6½ quarts	5½ quarts	
Engine coolant	(With reservoir at MAX level)	12.7 liters	13⅜ quarts	11⅞ quarts	Pre-diluted Genuine NISSAN Long Life Antifreeze/Coolant (blue) or equivalent *4
Automatic transmission fluid (ATF)		10.6 liters	11¼ quarts	9⅜ quarts	Genuine NISSAN Matic S ATF *5
Rear differential gear oil		2.6 liters	5½ pints	4⅝ pints	Genuine NISSAN Differential Oil Hypoid Super-S GL-5 synthetic 75W-90 or equivalent
Power steering fluid (PSF)		1.4 liters	3 pints	2½ pints	Genuine NISSAN PSF or equivalent *6
Brake fluid		—	—	—	Genuine NISSAN Super Heavy Duty Brake Fluid *7 or equivalent DOT 3 (US FMVSS No. 116)
Multi-purpose grease		—	—	—	NLGI No.2 (lithium soap base)
Windshield washer fluid		4.5 liters	4¾ quarts	4 quarts	Genuine NISSAN Windshield Washer Concentrate Cleaner & Antifreeze or equivalent
Air conditioning system refrigerant		850 ±50 grams	1.87 pounds (±0.11 lb)	1.87 pounds (±0.11 lb)	HFC-134a (R-134a) *8
Air conditioning system oil		180 milliliters	6.1 ounces	6.3 ounces	A/C System Oil Type S (DH-PS) *8

***1:** For additional information, refer to [Precaution for Fuel \(Unleaded Regular Gasoline Recommended\) – USA and Canada \(pg. 340\)](#).

***2:** For additional information, refer to [Engine Oil Recommendation – USA and Canada \(pg. 340\)](#).

***3:** As an alternative to this recommended oil, SAE 5W-30 or SAE 10W-30 conventional petroleum based oils may be used and meet all specifications and requirements necessary to maintain the New Vehicle Limited Warranty.

***4:** For additional information, refer to [Engine Coolant Recommendation – USA and Canada \(pg. 341\)](#).

RECOMMENDED FLUIDS AND LUBRICANTS – USA AND CANADA

[SPECIFICATIONS]

***5: If Genuine NISSAN Matic S ATF is not available, Genuine Matic J ATF may also be used. Using automatic transmission fluid other than Genuine NISSAN Matic S ATF or Matic J ATF will cause deterioration in driveability and automatic transmission durability, and may damage the automatic transmission, which is not covered by the Nissan new vehicle limited warranty.**

***6:** DEXRON™ VI type ATF may also be used.

***7:** Available in mainland U.S.A. through a NISSAN dealer.

***8:** For additional information, see “Air conditioner specification label” on the underside of the hood.

VK56VD (5.6L) Engine Equipped Models (Starting with 2017 Model Year)

Fluid Type		Capacity (Approximate)			Recommended Fluids/ Lubricants
		Metric Measure	US Measure	Imperial Measure	
Fuel		105.8 liters	28 gallons	23¼ gallons	Unleaded gasoline with an octane rating of at least 87 AKI (RON 91) *1
Engine oil Drain and refill	With oil filter change	6.5 liters	6⅞ quarts	5¾ quarts	<ul style="list-style-type: none"> • Genuine “NISSAN Motor Oil 0W-20 SN” (or equivalent) is recommended • If the above motor oil (or engine oil) is not available, a synthetic 0W-20 GF-5 SN motor oil (or engine oil) may be used. Damage caused by the use of motor oil (or engine oil) other than as recommended is not covered under NISSAN's New Vehicle Limited Warranty. For additional information, refer to “Engine oil recommendation”*2
	Without oil filter change	6.2 liters	6½ quarts	5½ quarts	
Engine coolant	(With reservoir at MAX level)	12.7 liters	13⅜ quarts	11⅞ quarts	Pre-diluted Genuine NISSAN Long Life Antifreeze/Coolant (blue) or equivalent *3
Automatic transmission fluid (ATF)		10.0 liters	10½ quarts	8¾ quarts	Genuine NISSAN Matic S ATF *4
Rear differential gear oil		2.6 liters	5 1/2 pints	4 5/8 pints	Genuine NISSAN Differential Oil Hypoid Super-S GL-5 synthetic 75W-90 or equivalent
Power steering fluid (PSF)		1.4 liters	3 pints	2½ pints	Genuine NISSAN PSF II or equivalent *5
Brake fluid		—	—	—	Genuine NISSAN Super Heavy Duty Brake Fluid *6 or equivalent DOT 3 (US FMVSS No. 116)

RECOMMENDED FLUIDS AND LUBRICANTS – USA AND CANADA

[SPECIFICATIONS]

Fluid Type	Capacity (Approximate)			Recommended Fluids/ Lubricants
	Metric Measure	US Measure	Imperial Measure	
Multi-purpose grease	—	—	—	NLGI No.2 (lithium soap base)
Windshield washer fluid	4.5 liters	4 ³ / ₄ quarts	4 quarts	Genuine NISSAN Windshield Washer Concentrate Cleaner & Antifreeze or equivalent
Air conditioning system refrigerant	850 ±50 grams	1.87 pounds (±0.11 lb)	1.87 pounds (±0.11 lb)	HFC-134a (R-134a) *7
Air conditioning system oil	180 milliliters	6.1 ounces	6.3 ounces	A/C System Oil Type S (DH-PS) *7

*1: For additional information, refer to [Precaution for Fuel \(Unleaded Regular Gasoline Recommended\) – USA and Canada \(pg. 340\)](#).

*2: For additional information, refer to [Engine Oil Recommendation – USA and Canada \(pg. 340\)](#).

*3: For additional information, refer to [Engine Coolant Recommendation – USA and Canada \(pg. 341\)](#).

***4: Using automatic transmission fluid other than Genuine NISSAN Matic S ATF or equivalent may cause deterioration in driveability and automatic transmission durability, and may damage the automatic transmission, which is not covered by the NISSAN New Vehicle Limited Warranty.**

*5: DEXRON™ VI type ATF may also be used.

*6: Available in mainland U.S.A. through a NISSAN dealer.

*7: For additional information, see “Air conditioner specification label” on the underside of the hood.

Precaution for Fuel (Unleaded Regular Gasoline Recommended) – USA and Canada

Use unleaded regular gasoline with an octane rating of at least 87 AKI (Anti-Knock Index) number (Research octane number 91).



CAUTION:

Do not use leaded gasoline. Using leaded gasoline will damage the three-way catalyst. Do not use E-85 fuel (85% fuel ethanol, 15% unleaded gasoline) unless the vehicle is specifically designed for E-85 fuel (i.e., Flexible Fuel Vehicle – FFV Models). Using a fuel other than that specified could adversely affect the emission control devices and systems, and could also affect the warranty coverage validity.

Engine Oil Recommendation – USA and Canada

Nissan recommends the use of a resource conserving oil in order to improve fuel economy. Select only engine oils that meet the American Petroleum Institute (API) certification and International Lubricant Standardization and Approval Committee (ILSAC) certification and SAE viscosity standard. These oils have the API certification mark on the front of the container. Oils which do not have the specified quality label should not be used as they could cause engine damage.

VQ40DE (4.0L) and VK56DE (5.6L) Engines

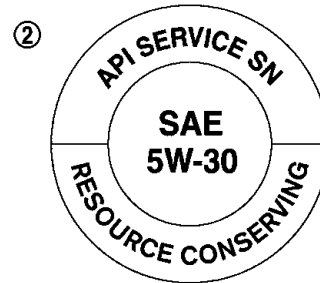

JSPIA0014ZZ

VK56VD (5.6L) Engine

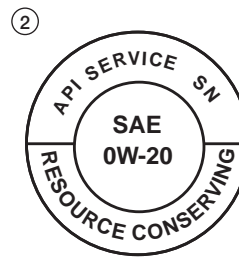
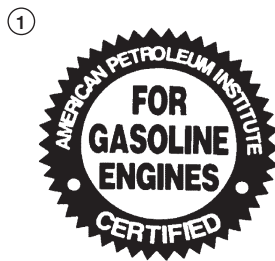

AAZIA0625ZZ

1. API certification mark

2. API service symbol

Engine Coolant Recommendation — USA and Canada

The engine cooling system is filled at the factory with a pre-diluted mixture of 50% Genuine NISSAN Long Life Antifreeze/Coolant (blue) and 50% water to provide year round antifreeze and coolant protection. The antifreeze solution contains rust and corrosion inhibitors. Additional cooling system additives are not necessary.



WARNING:

- **Never remove the radiator or coolant reservoir cap when the engine is hot. Wait until the engine and radiator cool down. Serious burns could be caused by high pressure fluid escaping from the radiator.**
- **The radiator is equipped with a pressure type radiator cap. To prevent engine damage, use only a Genuine NISSAN radiator cap.**

**CAUTION:**

- When adding or replacing coolant, be sure to use only Genuine NISSAN Long Life Antifreeze/Coolant (blue) or equivalent. Genuine NISSAN Long Life Antifreeze/Coolant (blue) is pre-diluted to provide antifreeze protection to -34° F (-37° C). If additional freeze protection is needed due to weather where the vehicle is operated, add Genuine NISSAN long life Antifreeze/Coolant (blue) concentrate following the directions on the container. If an equivalent coolant other than Genuine NISSAN Long Life Antifreeze/Coolant (blue) is used, follow the coolant manufacturer's instructions to maintain minimum antifreeze protection to -34° F (-37° C). The use of other types of coolant solutions other than Genuine NISSAN Long Life Antifreeze/Coolant (blue) or equivalent may damage the engine cooling system.
- Mixing any other type of coolant other than Genuine NISSAN Long Life Antifreeze/Coolant (blue), including Genuine NISSAN Long Life Antifreeze/Coolant (green), or the use of non-distilled water will reduce the life expectancy of the factory filled coolant.

RECOMMENDED FLUIDS AND LUBRICANTS — MEXICO

NOTE:

Refer to Service Manual for detailed service procedures.

VQ40DE (4.0L) Engine Equipped Models

Fluid Type		Capacity (Approximate)			Recommended Fluids/Lubricants
		Metric Measure	US Measure	Imperial Measure	
Fuel		105.8 liters	28 gallons	23¼ gallons	Unleaded gasoline with an octane rating of at least 87 AKI (RON 91)
Engine oil Drain and refill	With oil filter change	5.1 liters	5¾ quarts	4½ quarts	<ul style="list-style-type: none"> • Genuine NISSAN engine oil *1 • API grade SL, SM or SN *1 • ILSAC grade GF-2, GF-3, GF-4 or GF-5 *1
	Without oil filter change	4.8 liters	5⅛ quarts	4¼ quarts	
Engine coolant	(With reservoir at MAX level)	12.7 liters	13¾ quarts	11⅛ quarts	Genuine NISSAN Engine Coolant (blue) or equivalent *2
Automatic transmission fluid (ATF)		10.6 liters	11¼ quarts	9¾ quarts	Genuine NISSAN Matic S ATF *3
Rear differential gear oil		2.6 liters	5½ pints	4⅝ pints	Genuine NISSAN Differential Oil Hypoid Super-S GL-5 synthetic 75W-90 or equivalent
Power steering fluid (PSF)		1.4 liters	3 pints	2½ pints	Genuine NISSAN PSF or equivalent *4
Brake fluid		—	—	—	Genuine NISSAN Brake Fluid or equivalent DOT 3 or DOT 4 (US FMVSS No. 116) *6
Multi-purpose grease		—	—	—	NLGI No.2 (lithium soap base)
Windshield washer fluid		4.5 liters	4¾ quarts	4 quarts	Windshield washer fluid
Air conditioning system refrigerant		850 ±50 grams	1.87 pounds (±.11 lb)	1.87 pounds (±.11 lb)	HFC-134a (R-134a) *5
Air conditioning system oil		180 milliliters	6.1 ounces	6.3 ounces	A/C System Oil Type S (DH-PS) *5

***1:** For further details, refer to [Gasoline Engine Oil — Mexico \(pg. 345\)](#).

***2:** Use Genuine NISSAN Engine Coolant or equivalent in its quality, in order to avoid possible aluminium corrosion within the engine cooling system caused by the use of non-genuine engine coolant. Note that any repairs for the incidents within the engine cooling system while using non-genuine engine coolant may not be covered by the warranty even if such incidents occurred during the warranty period.

RECOMMENDED FLUIDS AND LUBRICANTS — MEXICO

[SPECIFICATIONS]

***3: If Genuine NISSAN Matic S ATF is not available, Genuine Matic J ATF may also be used. Using automatic transmission fluid other than Genuine NISSAN Matic S ATF or Matic J ATF will cause deterioration in driveability and automatic transmission durability, and may damage the automatic transmission, which is not covered by the NISSAN new vehicle limited warranty.**

***4:** DEXRON™ VI type ATF may also be used.

***5:** For further details, see “Air conditioner specification label” on the underside of the hood.

***6:** Never mix different types of brake fluids (DOT3 and DOT4).

VK56DE Engine Equipped Models — 2012-2014 Model Years

Fluid Type		Capacity (Approximate)			Recommended Fluids/Lubricants
		Metric Measure	US Measure	Imperial Measure	
Fuel		105.8 liters	28 gallons	23¼ gallons	Unleaded gasoline with an octane rating of at least 87 AKI (RON 91)
Engine oil Drain and refill	With oil filter change	6.5 liters	6⅞ quarts	5¾ quarts	<ul style="list-style-type: none"> • Genuine NISSAN engine oil *1 • API grade SL, SM or SN *1 • ILSAC grade GF-2, GF-3, GF-4 or GF-5 *1 • Viscosity SAE 5W-30 *1
	Without oil filter change	6.2 liters	6½ quarts	5½ quarts	
Engine coolant	(With reservoir at MAX level)	12.7 liters	13⅜ quarts	11⅞ quarts	Genuine NISSAN Engine Coolant (blue) or equivalent *2
Automatic transmission fluid (ATF)		10.6 liters	11¼ quarts	9⅜ quarts	Genuine NISSAN Matic S ATF *3
Rear differential gear oil		2.6 liters	5½ pints	4⅝ pints	Genuine NISSAN Differential Oil Hypoid Super-S GL-5 synthetic 75W-90 or equivalent *4
Power steering fluid (PSF)		1.4 liters	3 pints	2½ pints	Genuine NISSAN PSF or equivalent *5
Brake fluid		—	—	—	Genuine NISSAN Brake Fluid, or equivalent DOT 3 (US FMVSS No. 116)
Multi-purpose grease		—	—	—	NLGI No.2 (lithium soap base)
Windshield washer fluid		4.5 liters	4¾ quarts	4 quarts	Windshield washer fluid
Air conditioning system refrigerant		850 ±50 grams	1.87 pounds (±.11 lb)	1.87 pounds (±.11 lb)	HFC-134a (R-134a) *6
Air conditioning system oil		180 milliliters	6.1 ounces	6.3 ounces	A/C System Oil Type S (DH-PS) *6

***1:** For further details, refer to [Gasoline Engine Oil — Mexico \(pg. 345\)](#).

***2:** Use Genuine NISSAN Engine Coolant (blue) or equivalent in its quality, in order to avoid possible aluminium corrosion within the engine cooling system caused by the use of non-genuine engine coolant. Note that any repairs for the incidents within the engine cooling system while using non-genuine engine coolant may not be covered by the warranty even if such incidents occurred during the warranty period.

***3: If Genuine NISSAN Matic S ATF is not available, Genuine Matic J ATF may also be used. Using automatic transmission fluid other than Genuine NISSAN Matic S ATF or Matic J ATF will cause deterioration in driveability and automatic transmission durability, and may damage the automatic transmission, which is not covered by the NISSAN new vehicle limited warranty.**

***4:** It is recommended to see a NISSAN dealer for service for synthetic oil.

***5:** DEXRON™ VI type ATF may also be used.

***6:** For further details, see “Air conditioner specification label” on the underside of the hood.

SAE Viscosity Number — Mexico

Gasoline Engine Oil — Mexico

- 5W-30 is preferable. 10W-30 is also preferable and will improve fuel economy. If 5W-30 is not available, select the viscosity from the chart, that is suitable for the outside temperature range.

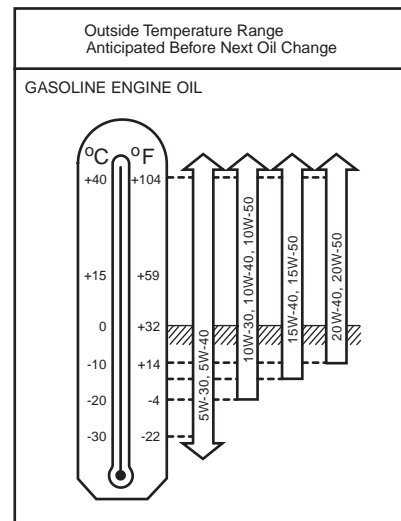

AAZIA0338GB

Engine Coolant Mixture Ratio

MIXTURE RATIO

The engine cooling system is filled at the factory with a high-quality, year-round, anti-freeze coolant solution. The anti-freeze solution contains rust and corrosion inhibitors. Therefore, additional cooling system additives are not necessary.

Protection for outside temperature down to:		Genuine NISSAN Engine Coolant or equivalent	Demineralized water or distilled water
°C	°F		
-15°	5°	30%	70%
-35°	-30°	50%	50%



CAUTION:

- When adding or replacing coolant, be sure to use only Genuine NISSAN Engine Coolant or equivalent in quality with the proper mixture ratio as specified.
- Other types of coolant solutions may damage your cooling system.

When checking the engine coolant mixture ratio with the coolant hydrometer, use the following chart to correct the hydrometer reading (specific gravity) according to the coolant temperature as show in the table.

Mixed Coolant Specific Gravity

Engine coolant mixture ratio	Coolant temperature °C (°F)			
	15° (59°)	25° (77°)	35° (95°)	45° (113°)
	Specific gravity			
30%	1.046 - 1.050	1.042 - 1.046	1.038 - 1.042	1.033 - 1.038
50%	1.076 - 1.080	1.070 - 1.076	1.065 - 1.071	1.059 - 1.065



WARNING:

Do not remove the radiator cap when the engine is hot. Serious burns could be caused by high pressure fluid escaping from the radiator. Wait until the engine and radiator cool down.

SUSPENSION

General Specification (Front)

Suspension type	Independent double wishbone coil over shock
Shock absorber type	Double-acting hydraulic
Stabilizer	Standard equipment

Wheel Alignment (Modified and Unladen*1)

Vehicle type		NV1500/2500	NV3500
Camber Degree minute (decimal degree)	Minimum RH	-0° 49' (-0.817°)	
	Nominal RH	0° 00' (0.00°)	
	Maximum RH	0° 49' (0.817°)	
	Minimum LH	-0° 31' (-0.517°)	
	Nominal LH	0° 18' (0.30°)	
	Maximum LH	1° 07' (1.117°)	
	Cross camber (LH-RH)	1° 07' (1.117°) MAX -0° 31' (-0.517°) MIN	
Caster Degree minute (decimal degree)	Minimum	5° 16' (5.27°)	5° 01' (5.02°)
	Nominal	6° 10' (6.17°)	5° 55' (5.92°)
	Maximum	7° 04' (7.07°)	6° 49' (6.82°)
	Cross caster	0° 49' (0.817°) or less	
Kingpin inclination (reference only) Degree minute (decimal degree)	8° 55' (8.92°)		

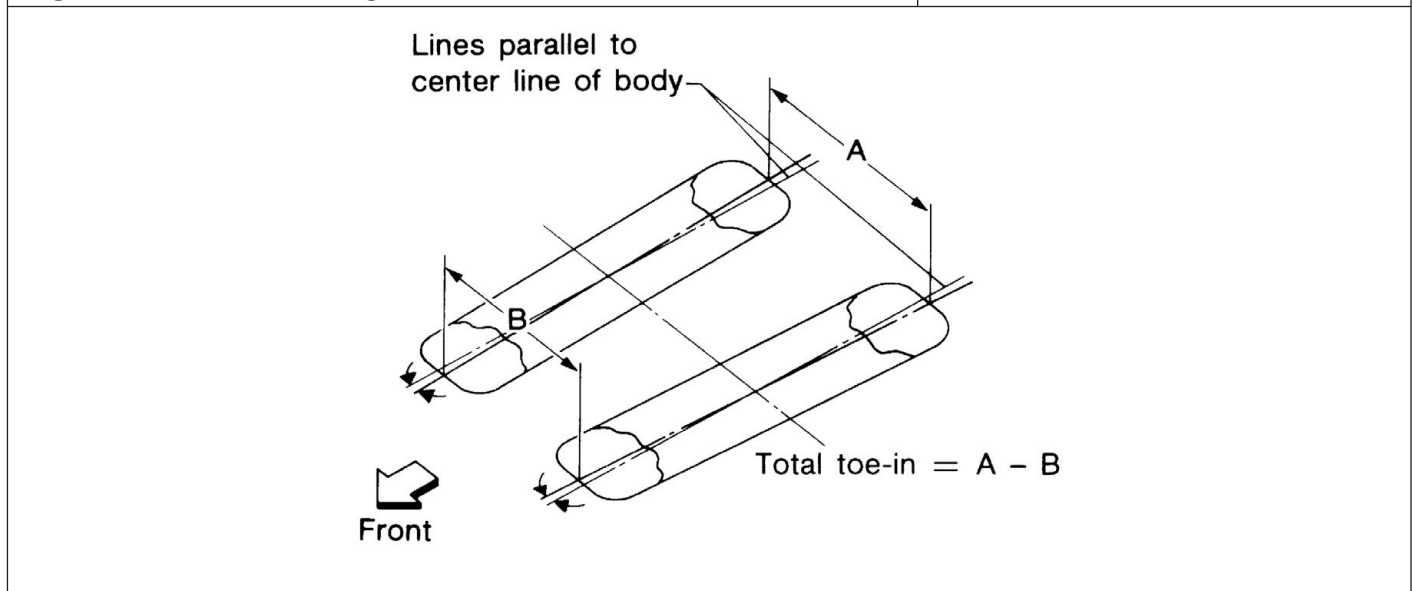

SUSPENSION

[SPECIFICATIONS]

Vehicle type		NV1500/2500	NV3500	
Toe-in	Distance (A – B)	Minimum	2.6 mm (0.102 in)	
		Nominal	6.0 mm (0.236 in)	
		Maximum	9.4 mm (0.370 in)	
	Angle (left or right) Degree minute (decimal degree)	Minimum	0° 10' (0.17°)	
		Nominal	0° 26' (0.44°)	
		Maximum	0° 43' (0.71°)	
Wheel turning angle (full turn) engine off	Inside Degree minute (decimal degree)	35° 30' – 39° 30' ^{*2} (35.50° – 39.50°)	35° 30' – 39° 30' ^{*2} (35.50° – 39.50°)	
	Outside Degree minute (decimal degree)	35° 30' (35.50°)	35° 30' (35.50°)	

*1: Fuel, engine coolant and engine oil full. Spare tire, jack, hand tools and mats in designated positions.

*2: Target value 38° 31' (38.52°)

General Specification (Rear)

Suspension type	Rigid axle with semi-elliptic leaf spring
Shock absorber type	Double-acting hydraulic

Wheelarch Height at Offline Curb Weight (Unladen*¹)

Vehicle type	NV1500/2500	NV3500
Tire Size	LT245/70R17	LT245/75R17
Front wheelarch height (Hf)	888 mm (35.0 in)	900 mm (35.4 in)
Rear wheelarch height (Hr)	922 mm (36.3 in)	947 mm (37.3 in)

*1: Fuel, engine coolant and engine oil full. Spare tire, jack, hand tools and mats in designated positions.

Wheelarch Height at Maximum Payload Weight*1

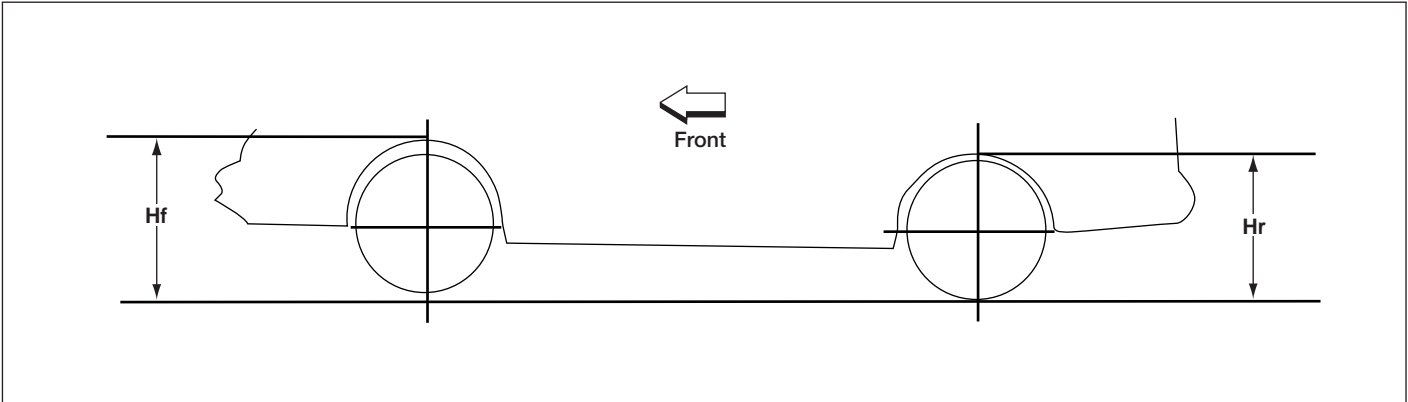

Vehicle type	NV1500/2500	NV3500
Tire Size	LT245/70R17	LT245/75R17
Front wheelarch height (Hf)	868 mm (34.2 in)	873 mm (34.4 in)
Rear wheelarch height (Hr)	850 mm (33.5 in)	869 mm (34.2 in)

*1: Fuel, engine coolant and engine oil full. Spare tire, jack, hand tools and mats in designated positions.

TURNING RADIUS

Curb-to-Curb

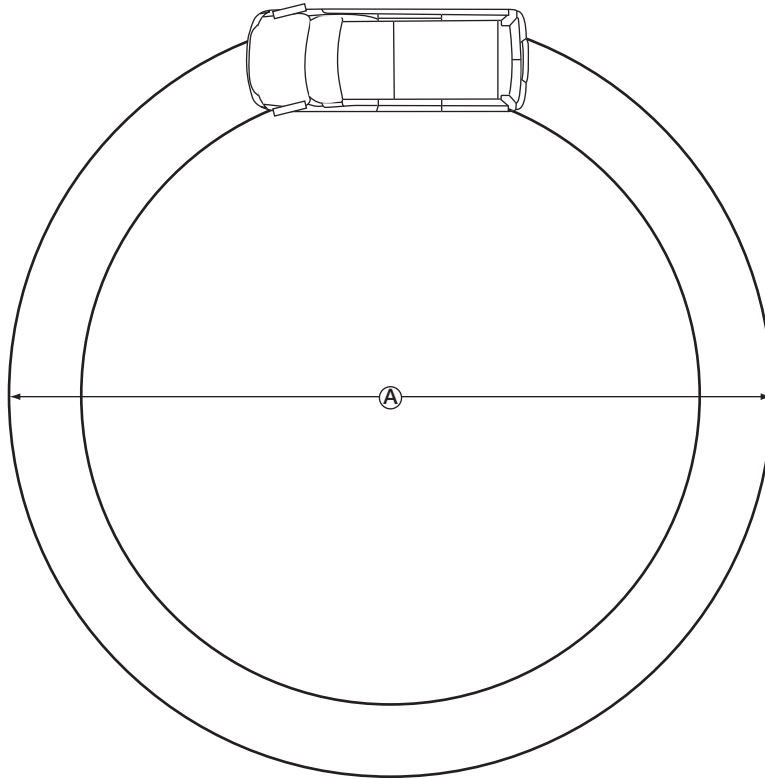

A. 13.8 m (45.2 ft)

AAZIA0062ZZ

WHEEL AND TIRE

Wheels and Tires

Equipment	Grade	Road wheel	Tire Size	Spare tire size
NV1500	S	17X7.5J Steel	LT245/70R17	LT245/70R17
	SV	17X7.5J Styled Steel		
NV2500	S, SV	17X7.5J Styled Steel	LT245/70R17	LT245/70R17
	SL*	17X7.5J Styled - Chrome Clad		
NV3500	S, SV	17X7.5J Styled Steel	LT245/75R17	LT245/75R17
	SL*	17X7.5J Styled - Chrome Clad		

*: SL grade new for 2015 model year.

Wheel Dimensions	
Diameter	17 in
Width	7.5 in
Offset	40 mm (1.6 in)
Bolt pattern	8 x 165.1 mm
Center bore	121.04 + 0.1 mm / -0.00 mm
Lug nut thread pitch	M14 x 1.5
Brake caliper clearance	4 mm (0.2 in)

BULBS

Exterior Lamps – 2012-2018 Model Years

Item		Wattage (W)*	Bulb No.*
Front combination lamp	Turn signal/parking lamp	27/7	3157AK
	Side marker	3.8	194K
	Headlamp low/high	55/65	H13
Rear combination lamp	Stop/tail lamp	27/8	3157KXRD
	Turn signal lamp	27	3156AK
	Back-up lamp	18	921
High-mounted stop lamp		18	921
License plate lamp		5	W5W

* Always check with an authorized NISSAN dealer for the latest parts information.

Exterior Lamps – 2019 Model Year

Item		Wattage (W)*	Bulb No.*
Front combination lamp	Turn signal/parking lamp	27/7	3157AK
	Side marker	3.8	194K
	Headlamp low/high	55/60	H13
Rear combination lamp	Stop/tail lamp	27/8	3157KXRD
	Turn signal lamp	27	3156AK
	Back-up lamp	18	921
High-mounted stop lamp		18	921
License plate lamp		5	W5W

* Always check with an authorized NISSAN dealer for the latest parts information.

Exterior Lamps – 2020-2021 model years

Item		Wattage (W)*	Bulb No.*
Front combination lamp	Turn signal/parking lamp	27/7	3157AK
	Side marker	3.8	194
	Headlamp low/high	55/60	H13
Rear combination lamp	Stop/tail lamp	27/8	3157KX
	Turn signal lamp	27	3156AK
	Back-up lamp	18	921
High-mounted stop lamp		18	921
License plate lamp		5	W5W

* Always check with an authorized NISSAN dealer for the latest parts information.

Interior Lamp/Illumination

Item	Wattage (W)*	Bulb No.*
Front room/map lamp	8	—
Cargo lamp	10	—

* Always check with an authorized NISSAN dealer for the latest parts information.

BATTERY

Battery — 2012-2016 Model Years

Application	Standard	Optional
Type*	GR24F	GR27F
Capacity (20 HR) minimum V-AH	12 - 70	12 - 80
Cold Cranking Current A [For reference value at -18°C (0°F)]	650	710

* Always check with an authorized NISSAN dealer for the latest parts information.

Battery — Starting with 2017 Model Year

Application	Standard
Type*	GR27F
Capacity (20 HR) minimum V-AH	12 - 80
Cold Cranking Current A [For reference value at -18°C (0°F)]	710

* Always check with an authorized NISSAN dealer for the latest parts information.

INVERTER SPECIFICATIONS

Rated voltage output		AC 120-volt (±10%)
Operating voltage range		DC 11.5-volt to 15-volt (Inverter terminal)
Rated power output	Low power mode	150-watt
	High power mode	400-watt
Output over-current protection	High power mode	3.7A or more
Input over-current protection	Low power mode	13.3A or more
Output frequency		60Hz (±10%)
Parasitic current		Less than 1 mA
Max. input current		45A (during continuous power)
Rated continuous power		400-watt @ 40°C (104°F) Maximum
Overheat protection (Thermistor)		100°C (212°F)

OVERHEAD BIN LOAD LIMIT

Overhead Bin Load Limit (High Roof Models Only)

Metric Measure	US Measure
4.54 kg	10 lbs

ACRONYMS

ACRONYM LIST

Acronym	Description
2WD	Two Wheel Drive
ABS	Anti-lock Braking System
AC	Alternating Current
A/C	Air Conditioning
AKI	Anti-Knock Index
AM/FM	Amplitude Modulated/Frequency Modulated
API	American Petroleum Institute
ARC	Accessory Reserve Capacity
A/T	Automatic Transmission
AT	Auto Transporter
ATV	All-Terrain Vehicle
BCM	Body Control Module
BT	Bus Trailer
CAN	Controller Area Network
CAN-H	Controller Area Network – High
CAN-L	Controller Area Network – Low
CD	C-Dolly
CG	Center of Gravity
CMVSS	Canadian Motor Vehicle Safety Standards
DTCs	Diagnostic Trouble Codes
ECM	Engine Control Module
EGI	Electronic Gasoline Injection
EVAP	Evaporative Emission
FCC	Federal Communications Commission (USA)
FFV	Flexible Fuel Vehicle
FMVSS	Federal Motor Vehicle Safety Standards
GAW	Gross Axle Weight
GAWR	Gross Axle Weight Rating
GCWR	Gross Combination Weight Rating
GVW	Gross Vehicle Weight
GVWR	Gross Vehicle Weight Rating
H.S.	Harness Side
HSS	High Strength Steel
HVAC	Heating, Ventilation, & Air Conditioning
IC	Inflatable Curtain
IDs	Identifications

Acronym	Description
ILSAC	International Lubricant Standardization and Approval Committee
IPDM E/R	Intelligent Power Distribution Module Engine Room
LDD	Load Divider Dolly
MH	Motor Home
MIL	Malfunction Indicator Light
MPV	Multi-purpose Passenger Vehicle
MSDS	Material Safety Data Sheet
NHTSA	National Highway Traffic Safety Administration
NNA	NISSAN North America
OEM	Original Equipment Manufacturer
ORVR	On-Board Refueling Vapor Recovery
OSHA	Occupational Safety and Health Act
PSF	Power Steering Fluid
RF	Radio Frequency
RFI	Radio Frequency Interference
RKE	Remote Keyless Entry
RPM	Revolutions Per Minute
RSS	Rear Sonar System
SAE	Society of Automotive Engineers
SB	School Bus
SgRP	Seating Reference Point
SRS	Supplemental Restraint System
SUB	Second Unit Body
TCD	Trailer Converter Dolly
TCM	Transmission Control Module
TPS	Throttle Position Sensor
TRA	Trailer
TRU	Truck
TT	Truck Tractor
USB	Universal Serial Bus
UVW	Unloaded Vehicle Weight
VDC	Vehicle Dynamic Control
VIN	Vehicle Identification Number

CONVERSION CHARTS

METRIC-ENGLISH CONVERSION CHART

Conversion Unit Type	Indicated Unit	Conversion Coefficient		
Length	km (mile)	km	mile	: 0.6214
	m (ft)	m	ft	: 3.281
	mm (in)	mm	in	: 0.03937
Temperature Difference	°C (°F)	°C	°F	: 1.8°C + 32
Mass	kg (lb)	kg	lb	: 2.205
	g (oz)	g	oz	: 0.03527
Force	kN (ton, US ton, Imp ton)	ton	kN	: 9.807
			US ton	: 1.102
			Imp ton	: 0.9842
	N (kg, lb)	kg	N	: 9.807
			lb	: 2.205
	N (g, oz)	g	N	: 0.009807
oz			: 0.03527	
Pressure	kPa (bar, kg/cm ² , psi)	kg/cm ²	kPa	: 98.07
			bar	: 0.9807
			psi	: 14.22
	kPa (mbar, mmHg, inHg)	mmHg	kPa	: 0.1333
			mbar	: 1.333
			inHg	: 0.03937
	kPa (mbar, mmH ₂ O, inH ₂ O)	mmH ₂ O	kPa	: 0.009807
			mbar	: 0.09807
			inH ₂ O	: 0.03937
Inflation Pressure	kg/cm ² , (kPa, bar, psi)	kg/cm ²	kPa	: 98.07
			bar	: 0.9807
			psi	: 14.22
Speed	m/s (ft/s)	m/s	ft/s	: 3.281
	km/h (MPH)	km/h	MPH	: 0.6214
Cooling / Heating Capacity	kW (kcal/h, BTU/h)	kcal/h	kW	: 0.001163
			BTU/h	: 3.968
Unbalance	g·cm (oz·in)	g·cm	kcal/h	: 859.8
			oz·in	: 0.01389
Torque	N·m (kg·m, ft·lb, in·lb)	kg·m	N·m	: 9.807
			ft·lb	: 7.233
			in·lb	: 86.80
	N·m (kg·cm, in·lb)	kg·cm	N·m	: 0.09807
			in·lb	: 0.8680

METRIC-ENGLISH CONVERSION CHART

[CONVERSION CHARTS]

Conversion Unit Type	Indicated Unit	Conversion Coefficient			
Volume	<Fluid> ℓ (US gal, Imp gal)	ℓ	US gal	: 0.2642	
			Imp gal	: 0.2200	
	ℓ (US qt, Imp qt)		US qt	: 1.057	
			Imp qt	: 0.8801	
	ℓ (US pt, Imp pt)		US pt	: 2.114	
			Imp pt	: 1.760	
	<Fluid> ml (US fl oz, Imp fl oz)		ml	US fl oz	: 0.03381
				Imp fl oz	: 0.03520
<Displacement> cm ³ / (cu in)	cm ³	cu in	: 0.06102		
Spring Constant	N/mm (kg/mm, lb/in)	kg/mm	N/mm	: 9.807	
			lb/in	: 56.00	

INCH-MILLIMETER EQUIVALENTS CHART

[CONVERSION CHARTS]

INCH-MILLIMETER EQUIVALENTS CHART

Fraction inches	Decimal inches	Metric mm
1/64	0.015625	0.39688
1/32	0.03125	0.79375
3/64	0.046875	1.19062
1/16	0.0625	1.58750
5/64	0.078125	1.98437
3/32	0.09375	2.38125
7/64	0.109375	2.77812
1/8	0.125	3.1750
9/64	0.140625	3.57187
5/32	0.15625	3.96875
11/64	0.171875	4.36562
3/16	0.1875	4.76250
13/64	0.203125	5.15937
7/32	0.21875	5.55625
15/64	0.234375	5.95312
1/4	0.250	6.35000
17/64	0.265625	6.74687
9/32	0.28125	7.14375
19/64	0.296875	7.54062
5/16	0.3125	7.93750
21/64	0.328125	8.33437
11/32	0.34375	8.73125
23/64	0.359375	9.12812
3/8	0.375	9.52500
25/64	0.390625	9.92187
13/32	0.40625	10.31875
27/64	0.421875	10.71562
7/16	0.4375	11.11250
29/64	0.453125	11.50937
15/32	0.46875	11.90625
31/64	0.484375	12.30312
1/2	0.500	12.70000

Fraction inches	Decimal inches	Metric mm
33/64	0.51625	13.09687
17/32	0.53125	13.49375
35/64	0.546875	13.89062
9/16	0.5625	14.28750
37/64	0.578125	14.68437
19/32	0.59375	15.08125
39/64	0.609375	15.47812
5/8	0.625	15.87500
41/64	0.640625	16.27187
21/32	0.65625	16.66875
43/64	0.671875	17.06562
11/16	0.6875	17.46250
45/64	0.703125	17.85937
23/32	0.71875	18.25625
47/64	0.734375	18.65312
3/4	0.750	19.05000
49/64	0.765625	19.44687
25/32	0.78125	19.84375
51/64	0.796875	20.24062
13/16	0.8125	20.63750
53/64	0.828125	21.03437
27/32	0.84375	21.43125
55/64	0.859375	21.82812
7/8	0.875	22.22500
57/64	0.890625	22.62187
29/32	0.90625	23.01875
59/64	0.921875	23.41562
15/16	0.9375	23.81250
61/64	0.953125	24.20937
31/32	0.96875	24.60625
63/64	0.984375	25.00312
1	1.00	25.40000

ACRONYMS

ACRONYM LIST 356

ADD ON EQUIPMENT

ANTI-CORROSION PROTECTION 323
 Bulkhead 324
 High Roof 335
 ROOF RACKS 333
 Shelving 327
 SHELVING AND BULKHEAD INSTALLATION 324
 Standard Roof 334

BODY DIMENSIONS

Back Door Opening Measurements 208
 CARGO AREA 174
 Crossmember and Body Mount Dimensions 213
 D-Ring Tie-Downs 182
 Dimensions 169
 Doors and Mirrors Dimensions 210
 EXTERIOR 203
 Exterior Overall Dimensions 211
 FRAME/BODY 213
 Front Center Console Removal and Installation 167
 Front Door Opening Measurements 203
 Front Seat Armrest Removal and Installation 168
 High Roof 209
 Interior Dimensions 174
 PASSENGER COMPARTMENT 167
 PLACARDS 202
 Seat Mounting Holes 170
 Seat Position Diagrams 171
 SIGN AREA — HIGH ROOF 192
 SIGN AREA — STANDARD ROOF 183
 Slide Door Opening Measurements — With Slide
 Door Installed 206
 Slide Door Opening Measurements — Without Slide
 Door Installed 204
 Wheel Well Clearance 179

CONVERSION CHARTS

INCH-MILLIMETER EQUIVALENTS CHART 360
 METRIC-ENGLISH CONVERSION CHART 358

DESIGN REQUIREMENTS FOR MODIFICATIONS

ADHESIVE INFORMATION 321
 Changes To The HVAC System 292
 COOLING 291
 DRIVELINE 301
 Engine Cooling System 291
 EXHAUST 295
 Exhaust System 295
 FRAME 303
 General 299
 HIGH STRENGTH STEEL LOCATIONS 307
 HVAC 292
 HVAC System Component Locations 292

JACK 304
 Jacking and Lifting Points 304
 Modifications in the Vehicle Interior 310
 MSDS Information 321
 PAINT GENERAL INFORMATION 311
 PAINT WORK — 2012 Model Year 312
 PAINT WORK — 2013 Model Year 313
 PAINT WORK — 2014 Model Year 314
 PAINT WORK — 2015 Model Year 315
 PAINT WORK — 2016-2020 Model Years 317
 PAINT WORK — Starting with 2021 Model Year 319
 Rear Sonar System 293
 REPLACING BOLTS 322
 SONAR SYSTEM 293
 STEERING AND SUSPENSION 300
 Tightening Torque Table 322
 TRANSMISSION 302
 Vehicle Handling Information 300
 VEHICLE INTERIOR 310
 WELDING 309
 WHEEL AND TIRE 299

ELECTRICAL

Added Lights or Accessories Controlled By Added
 Switches 265
 ADDING LIGHTS OR DEVICES 265
 Back Door LH Harness (High Roof) 256
 Back Door LH Harness (Standard Roof) 257
 Back Door RH Harness (High Roof) 258
 Back Door RH Harness (Standard Roof) 259
 BATTERY VOLTAGE CONNECTION 230
 BATTERY VOLTAGE CONTROL SYSTEM 229
 Body Harness (High Roof) 246
 Body Harness (Standard Roof) 247
 Body No. 2 Harness (High Roof) 248
 Body No. 2 Harness (Standard Roof) 249
 BULBS 260
 Chassis Harness (Except VK56VD 5.6L) (2012 - 2016
 Model Years) 238
 Chassis Harness (VK56VD 5.6L) (Starting in
 2017) 239
 Component Parts Location 268
 CUSTOMER PRE-WIRING ACCESS 231
 DATA LINK CONNECTOR LOCATION (FOR DIAGNOS-
 TIC SCAN TOOL) 216
 Description 267
 Electrical Wiring — Adding Lights or Electrical
 Devices 265
 Engine Control Harness (VK56DE 5.6L) (2012-2016
 Model Years) 244
 Engine Control Harness (VK56VD 5.6L) (Starting 2017
 Model Year) 245
 Engine Control Harness (VQ40DE 4.0L) 243
 Engine Room Harness (Except VK56VD 5.6L) (2012 -
 2017 Model Year) 240

Engine Room Harness (Passenger Compartment) 242

Engine Room Harness (VK56VD 5.6L) (Starting in 2017) 241

Front Door LH Harness 252

Front Door RH Harness 253

FRONT FOG LAMP AIMING 264

FUSE AND RELAY INFORMATION 221

GROUNDS 228

HARNESS LAYOUT 235

Harness Outline (High Roof) 235

Harness Outline (Standard Roof) 236

HEADLAMP AIMING 261

Inspection 261

INVERTER SPECIFICATIONS 269

INVERTER SYSTEM 267

Main Harness 237

Permissible Ground Location 228

Radio Frequency Interference (RFI) 265

REGULATIONS FOR ADDING COMMUNICATION EQUIPMENT 266

REMOTE KEYLESS ENTRY SYSTEM 270

Room Lamp Harness (High Roof) 250

Room Lamp Harness (Standard Roof) 251

SELF-TEST MODE 215

SHIPPING MODE (EXTENDED) STORAGE SYSTEM CANCEL 218

Sliding Door Harness (High Roof) 254

Sliding Door Harness (Standard Roof) 255

Speaker Wiring 234

Telematics Connector Terminal Layout 233

TRANSIT AND SHIPPING (EXTENDED STORAGE) MODE CONTROL SYSTEMS 217

Upfitter Pre-Wiring 231

Vertical Aiming Adjustment Procedure 262

FUEL SYSTEMS

Chassis 273

Drilling Precaution Area 276

FILLER NECK AREAS 273

Fuel Filler Pipe and EVAP Canister Location 274

Fuel Pressure Release Procedure 272

FUEL SYSTEM PRECAUTIONS 271

General 271

TANK LOCATION 275

Tank Mounting 275

GENERAL INFORMATION

Canada 10

CONTACT INFORMATION 7

DEFINITIONS OF TERMS 9

Disclaimer 5

DISCLAIMER 5

Important Regulatory Information 5

SERVICE INFORMATION AND TOOLS 6

USA 9

WARRANTY 8

MODEL INFORMATION

2012–2014 Model Variation 63

2015–2016 Model Variation 65

2017 Model Variation 69

2018 Model Variation 72

2019–2020 Model Variations 75

2021 Model Variations 78

CLASS 63

Determining Available Towing Capacity 80

GVWR/TOWING CAPACITY 80

Identification Number 60

LABEL INFORMATION 60

VAN OPTION MASS — 2012–2013 MODEL YEARS 82

VAN OPTION MASS — 2014 MODEL YEAR 84

VAN OPTION MASS — 2015–2016 MODEL YEARS 86

VAN OPTION MASS — 2017 MODEL YEAR 88

VAN OPTION MASS — 2018 MODEL YEAR 90

VAN OPTION MASS — 2019 MODEL YEAR 91

VAN OPTION MASS — 2020 MODEL YEAR 92

VAN OPTION MASS — 2021 MODEL YEAR 93

VEHICLE CODING INFORMATION 61

Vehicle Identification 61

RESOURCE CHARTS

EXTERIOR MEASUREMENTS — HIGH ROOF 164

EXTERIOR MEASUREMENTS — STANDARD ROOF 127

INTERIOR MEASUREMENTS — HIGH ROOF 162

INTERIOR MEASUREMENTS — STANDARD ROOF 125

WEIGHTS — HIGH ROOF, 2012 MODEL YEAR 132

WEIGHTS — HIGH ROOF, 2013–2014 MODEL YEARS 135

WEIGHTS — HIGH ROOF, 2015–2016 MODEL YEARS 138

WEIGHTS — HIGH ROOF, 2017 MODEL YEAR 143

WEIGHTS — HIGH ROOF, 2018 MODEL YEAR 147

WEIGHTS — HIGH ROOF, 2019 MODEL YEAR 151

WEIGHTS — HIGH ROOF, 2020 MODEL YEAR 155

WEIGHTS — HIGH ROOF, 2021 MODEL YEAR 159

WEIGHTS — STANDARD ROOF, 2012 MODEL YEAR 94

WEIGHTS — STANDARD ROOF, 2013–2014 MODEL YEARS 97

WEIGHTS — STANDARD ROOF, 2015–2016 MODEL YEARS 101

WEIGHTS — STANDARD ROOF, 2017 MODEL YEAR 105

WEIGHTS — STANDARD ROOF, 2018 MODEL YEAR 109

WEIGHTS — STANDARD ROOF, 2019 MODEL YEAR 113

WEIGHTS — STANDARD ROOF, 2020 MODEL YEAR 117

WEIGHTS — STANDARD ROOF, 2021 MODEL YEAR 121

SAFETY INFORMATION

ALTERED VEHICLES 30

BRAKE COMPLIANCE GUIDELINES 32

CENTER OF GRAVITY (CG) 33

FMVSS AND CMVSS REGULATION LIST 58

FRONT AIR BAG DEPLOYMENT ZONES 15

PRECAUTIONS 59

Precautions For Electrical CAN (Controller Area Network) System	59	BULBS	352
Precautions for Supplemental Restraint System (SRS) "Air Bag" and "Belt Pre-Tensioner"	12	INVERTER SPECIFICATIONS	354
Precautions When Using Power Tools (Air or Electric) and Hammers	12	OVERHEAD BIN LOAD LIMIT	355
Recommended Procedure	34	RECOMMENDED FLUIDS AND LUBRICANTS — MEXICO	343
Safety / Emissions	30	RECOMMENDED FLUIDS AND LUBRICANTS — USA AND CANADA	336
Standards	58	SUSPENSION	347
SUPPLEMENTAL RESTRAINT SYSTEM (SRS) COMPONENT LOCATIONS	13	TURNING RADIUS	350
SUPPLEMENTAL RESTRAINT SYSTEM (SRS) PRECAUTIONS	12	WHEEL AND TIRE	351
Vehicle Center of Gravity Envelope — Unloaded		TRAILER TOW	
Vehicle Weight (UVW)	37	Adding A Hitch	288
Vehicle Center of Gravity Measurement Process	33	BRAKE CONTROLLER	286
SPECIFICATIONS		System Description	285
BATTERY	353	System Diagram	285
		TRAILER HITCH	288
		Trailer Wiring	281
		WIRING	281