

New for 2018

# WEBTEC









## Short Form Catalogue



Hydraulic measurement and control



## Contents

	General Information	2 - 3
	Portable Hydraulic Testers	4 - 8
	Flowmeters, Pressure Transducers, Temperature Sensors, Readouts and Hydraulic Data Acquisition Equipment	9 - 16
	'MecMeter' <sup>™</sup> In-Line Flowmeters & Flow Test Kits	17 - 18
	WP Series Low Cost In-Line Flowmeters	19
	Pressure Test Kits, Gauges & Pressure Test Points	20 - 21
	Custom hydraulic test kits	22
	Hydraulic Components; Valves, Pumps & Motors	23 - 28
	Technical Information	29 - 44



## Hydraulic measurement and control

### Experience

Over 50 years of product development enhanced by constant technical innovation to meet the ever changing needs of fluid power users.

### Support

Located in Milwaukee, Wisconsin, with distributors across North and Central America, we provide product engineering and support before, during and after the sale. We aim for same day shipment on stock items. Other locations include England, France, Germany and Hong Kong for worldwide support.

### Quality

Dedication to quality starts with design and is carried through all stages of manufacture. This commitment and ability to meet demanding criterion is demonstrated by our accreditation to ISO9001.

### A Complete Line

Over 350 different portable hydraulic testers, flowmeters, pressure transducers, temperature sensors, speed sensors, hydraulic data acquisition systems and digital display units all designed to be easy to use, accurate and durable. For trouble shooting & testing of components or commissioning hydraulic circuits on mobile equipment, industrial machinery, hydraulic test stands or in the laboratory, we can help you perform your job quickly, efficiently and professionally. We also offer a range of high quality zero leak directional control valves available in aluminum or SST body. Our enhanced line of pressure compensated fixed and variable priority flow controls offer exceptional stability and optimized energy efficiency.

## General Information

### Customer Satisfaction

We strive to provide the highest level of customer service possible while manufacturing the most progressive and the highest quality line of hydraulic test equipment available on the market today. If for any reason you are not satisfied with the performance of the item purchased or the level of service you receive, please call and let us know.

**A satisfied customer is the best and most honest form of advertising we know.**

### How to get Technical Information

Call, fax, email or mail us. Call toll free in the US or Canada, **800-WEBTEST (800-932-8378)**, telephone: **(414) 769-6400**, Toll Free Fax: **866-FLOWMETER (866-356-9637)** or **414-769-6591**. Our email address is **sales-us@webtec.com**. Our website address is **www.webtec.com**. Correspondence can be sent to 1290 E. Waterford Ave. Milwaukee, WI 53235.

### How to Open an Account

NET 30 day accounts can be opened with approved credit. To apply send bank reference, two trade references and your federal tax ID number. Credit card orders or COD shipments can be made for other accounts, as well as overdue accounts.

### How to get Delivery Information

Call, fax, email or mail us. Our toll free phone number is **800-WEBTEST (800-932-8378)** or **414-769-6400**, Our Toll Free Fax is: **866-FLOWMETER (866-356-9637)** or **414-769-6591** and our email is **sales-us@webtec.com**. We aim to ship same day via UPS standard service on orders placed before 1:00 pm - our UPS driver collects around 3:00 pm and we like to have a couple of hours to process paperwork and package the goods. However if you need something shipped same day by next day air or second day air the major carriers will pickup until 7:00 pm - we will do our best to process your order, even if you call after 1:00 pm. We can also ship Federal Express, Emery, Burlington or TNT.

### How to Order

To order, call, fax, email or mail us. Our toll free phone number is **800-WEBTEST (800-932-8378)** or **414-769-6400**, Our Toll Free Fax is: **866-FLOWMETER (866-356-9637)** or **414-769-6591** and our email is **sales-us@webtec.com**. The order desk is manned from 8:00 am to 5:00 pm Central Time, Monday through Friday - ask for the order desk. Outside these hours there is an automated attendant system, leave a message with your name and number and we will get back to you. The fax machine has its own line and is always open. Please note, we have a minimum order for the most up-to-date and complete information, please visit <https://www.webtec.com/about/our-certificates> and download our Terms and Conditions.

### Stocking Policy

We endeavor to hold stock of popular items in Milwaukee. If you are a distributor and have a good established pattern you may want to hold stock to ensure faster product availability.

### How to get Literature

Call our toll free phone number **800-WEBTEST (800-932-8378)** or email us at **sales-us@webtec.com**

Our website [www.webtec.com](http://www.webtec.com) has all literature available for download in several different languages.

### How to Process Repairs

We like to think our equipment never goes wrong but if it does we will do our best for you. Call for an RGA# before returning your repair. A written estimate will be provided before we proceed. Occasionally we get units back with no paperwork at all - no address, no phone, no name. Please be sure to get your RGA # before returning any unit as we can not provide the high level of service you deserve without this important information.

### Shortages / Damaged in Transit / Returned Goods

Shortages must be reported within 10 days of shipment. Goods damaged in shipment are the responsibility of the carrier and all claims must be submitted to the carrier.

**Returned goods not proven to be defective due to materials or workmanship will be subject to a minimum 25% restocking fee.**

**Mastercard, Visa, and American Express are all accepted.**



To read our full terms and conditions of business please go to [www.webtec.com](http://www.webtec.com)

# DHT 1 & 2 Series Digital Hydraulic Testers

## Standard Features:

- High Contrast LCD Digital readout
- Bi-directional Loading Valve with “**INTERPASS**”™ Burst Disc Protection
- Bi-directional flow & pressure readings
- Flow accuracy 1% of reading
- US & Metric units, button select (DHTxx2 series only)
- Portable (DHT402 only 14 lbs)
- RPM input circuitry (DHTxx2 series)



- EP seals optional
- Remote flow & temperature input is easily field calibrated for any LT series flowmeter (DHTxx2 series only)
- DHT 1 Series features simple on/off control
- CMOS low-power circuitry with “Auto-Off” extends battery life
- 6,000 psi Pressure Gauge (8500 psi DHT802) DHT802/801

Model Number	Flow range (US gpm)	Inlet/Outlet Ports	Max. Pressure (psi)	Remote Flow Input	Weight (lbs)	Approximate Dimensions (W x D x H)	Temperature Range Internal	RPM Range & Remote
DHT401-S-6	2.5 - 100	1-5/16" -12UN #16 SAE ORB	6000	N/A	14	9.5" x 7.9" x 7.9"	32 - 250 °F (°C and lpm engineering units available)	N/A
DHT801-F-3*	5 - 210	1-1/2" #24 SAE Code 61 4-bolt flange	3000		22	9.7" x 8.9" x 8.9"		
DHT801-S-7*	5 - 210	1-7/8" -12UN #24 SAE ORB	7000		22	9.7" x 8.9" x 8.9"		
DHT302-S-6	2 - 80	1-5/16" -12UN #16 SAE ORB	6000	DHT Series 2 Testers EXTernal input is easily configured in the field to any LT series flowmeter	14	9.5" x 7.9" x 7.9"	32 - 250 °F 0 - 120 °C Push Button Select	0 - 6000
DHT402-S-6	2.5 - 100							
DHT602-S-7*	5 - 160	1-7/8" -12UN #24 SAE ORB	7000		22	9.7" x 8.9" x 8.9"		
DHT602-F-3*	5 - 160	1-1/2" #24 SAE Code 61 4-bolt flange	3000		22			
DHT802-F-3*	5 - 210							
DHT802-S-7*	5 - 210	1-7/8" -12UN #24 SAE ORB	7000		22			

# DHM 4 Series Digital Hydraulic Multimeter

## Standard Features:

- PRODUCE an electronic report for immediate email to the customer
- FLOW 10-800 lpm, 2.5-210 US gpm
- PRESSURE 480 bar, 7000 psi
- PEAK PRESSURE capture at 1000 times/s
- ACCURATE measurements and FAST response bar graphs to aid diagnosis.
- BUILT-IN loading valve.



- BI-DIRECTIONAL operation.
- INTERNAL oil by-pass protects the meter and system against overpressure.
- AUTOMATIC calculation of hydraulic power and volumetric efficiency.
- RECORD data to robust, non-volatile memory.
- PORTABLE, robust and sealed to IP54.

Model number	Flow range	Pressure range	Fluid temp. range	Inlet/outlet ports
DHM404-B-6	10 - 400 LPM	0 - 420 bar	0 - 105°C	1" BSPP
DHM404-S-6	2.5 - 100 US gpm	0 - 6000 psi	32 - 220 °F	1-5/16" -12UN #16 SAE ORB
DHM804-S-7-L*	20 - 800 LPM	0 - 480 bar	0 - 105 °C	1-7/8" -12UN #24 SAE ORB
DHM804-S-7*	5 - 210 US gpm	0 - 7000 psi	32 - 220 °F	1-7/8" -12UN #24 SAE ORB

\* DHM804 has limited pressure control below 86 lpm (23 US gpm). The maximum controllable pressure in this region is calculated by:  $\text{max pressure (in bar)} = 5 \times \text{flow (lpm)} + 30$

# HT 2 Series Analog Hydraulic Testers

## Standard Features:

- Analog readout of flow, pressure, temperature & RPM
- Bi-directional Loading Valve with "INTERPASS"™ Burst Disc Protection
- Bi-directional flow & pressure
- Flow Accuracy  $\pm 1\%$  FSD
- Dual Scale, US & Metric
- High/Low flow scales offer improved resolution
- Portable (HT402 only 14 lbs)
- Battery test switch position



- RPM input accepts signal from TH3 phototach for shaft rotational speed display
- CMOS low-power circuitry
- "Auto-Off" extends battery life
- Pressure gauge is connected via built-in shuttle valve always indicating high pressure side of load valve regardless of flow direction
- EP seals optional

Model Number	Calibrated Flow Range (US gpm)		Inlet/Outlet Ports	Max. Pressure (psi)	Weight (lbs)	Approximate Dimensions (W x D x H)	Temperature Range Internal & Remote	rpm Range 1 PPR - Phototach
	Low Scale	High Scale						
HT302-S-6	3 - 20	13 - 80	1-5/16" -12UN #16 SAE ORB	6000	14	9.5" x 7.9" x 7.9"	32 - 250 °F 0 - 120 °C Dual Scale	300 - 3000
HT402-S-6	3 - 25	13 - 105						300 - 4000
HT602-S-7*	6 - 40	25 - 160	1-7/8" -12UN #24 SAE ORB	7000	22	9.7" x 8.9" x 8.9"	32 - 250 °F 0 - 120 °C Dual Scale	300 - 6000
HT602-F-3*	6 - 40	25 - 160	1-1/2" #24 SAE Code 61 4-bolt flange	3000	22			300 - 6000
HT802-F-3*	6 - 50	25 - 210						300 - 5000
HT802-S-7*	6 - 50	25 - 210	1-7/8" -12UN #24 SAE ORB	7000	22			300 - 5000

## \* Performance Notes

All 600 and 800 Testers have limited pressure control below 23 USgpm (86 lpm). The maximum controllable pressure in this region is calculated by: max pressure (psi) = 289 x flow (gpm) +436.

# RFIK Series Mechanical Hydraulic Tester

## Standard Features:

- Flow: 0.5 - 54 US gpm
- Pressure: Up to 6000 psi
- Temperature: 68 - 248 °F
- Allows reverse flow
- No batteries required



- Flow Accuracy within 4% FSD
- Large clear easy to read dials
- Smooth pressure control up to 6000 psi
- Safe to use, with "INTERPASS"™ internal safety protection system. Protects system and operator against accidental over-pressure in both flow directions

Model Number	Calibrated Flow Range (lpm)		Inlet fitting	Outlet fitting
	Low Scale	High Scale		
RFIK030-S-6	2 - 30	0.5 - 8	1-1/16" - 12UN JIC Male	1-1/16" - 12UN JIC Male
RFIK060-S-6	5 - 60	1 - 16	1-1/16" - 12UN JIC Male	1-1/16" - 12UN JIC Male
RFIK120-S-6	10 - 120	4 - 32	1-5/16" - 12UN JIC Male	1-5/16" - 12UN JIC Male
RFIK200-S-6	10 - 200	4 - 54	1-5/16" - 12UN JIC Male	1-5/16" - 12UN JIC Male

## DHCR Series Digital hydraulic readout

### Standard Features:

- Remote digital readout
- Bi-directional flow & pressure
- Flow accuracy up to 1% of Reading
- 2 Flow & temp inputs, 1 RPM input
- US & Metric units selectable
- 9 V battery powered
- EP seals optional
- M16x2 male pressure connection



DHCR Remote Digital Hydraulic Tester

- “Auto-Off” extends battery life
- Remote flow & temperature input is easily field calibrated for any LT series flowmeter
- Flow meters available with built-in loading valve “**INTERPASS**”™ burst disc safety feature
- Build a test system by selecting the DHCR readout, LT or LTR flow meter, cable/hose assembly & optional carry case.

Model number	Max Pressure (psi)
DHCR-6	6000
DHCR-7	7000

## Choose your Flow block

### LT Series Turbine flow meters with frequency output

#### Standard Features:

- Flow: 0.25 - 400 US gpm
- Pressure: Up to 7000 psi
- Accuracy: Up to 1% of indicated reading
- Frequency Output
- M16 x 2 male test point included



- Bi-directional operation
- Temperature: sensor built-in
- Fluids: Wide range of hydraulic oil, lubrication oil, and fuels
- Calibration: 21 cSt as standard. Special calibration possible

Model Number	Main ports	Top ports	Flow Range (US gpm)	Maximum pressure (psi)
LT15-FM-S-S-6	3/4" -16UN #8 SAE ORB	7/16" -20UN #4 SAE ORB*	0.25 - 4	6000
LT60-FM-S-S-6	1-1/16" -12UN #12 SAE ORB	7/16" -20UN #4 SAE ORB	0.8 - 16	6000
LT150-FM-S-S-6	1-1/16" -12UN #12 SAE ORB	7/16" -20UN #4 SAE ORB	1.3 - 40	6000
LT300-FM-S-S-6	1-5/16" -12UN #16 SAE ORB	7/16" -20UN #4 SAE ORB	2 - 80	6000
LT400-FM-S-S-6	1-5/16" -12UN #16 SAE ORB	7/16" -20UN #4 SAE ORB	2.5 - 100	6000
LT600-FM-S-S-5	1-5/8" -12UN #20 SAE ORB	7/16" -20UN #4 SAE ORB	4 - 160	5000
LT600-FM-F-S-3	1-1/2" #24 SAE Code 61 4-bolt flange	7/16" -20UN #4 SAE ORB	4 - 160	3000
LT800-FM-S-S-7	1-7/8" -12UN #24 SAE ORB	7/16" -20UN #4 SAE ORB	5 - 210	7000
LT800-FM-F-S-3	1-1/2" #24 SAE Code 61 4-bolt flange	7/16" -20UN #4 SAE ORB	5 - 210	3000
LT1500-FM-F-S-6	2" #32 SAE Code 62 4-bolt flange	7/16" -20UN #4 SAE ORB	12.5 - 400	6000

\* Only one test port

### LTR Series Turbine flow meters with built-in loading valve

#### Standard Features:

- Flow: 2 - 210 gpm
- Pressure: Up to 7000 psi
- Accuracy: Up to 1% of indicated reading
- Frequency Output
- Bi-directional operation
- Temperature: sensor built-in
- Fluids: Wide range of hydraulic oil, lubrication oil, and fuels



- Calibration: 21 cSt as standard. Special calibration possible
- Loading Valve: with bi-directional flow and pressure loading capability
- “**INTERPASS**”™ safety disc system, bypasses oil internally in the event of the valve being over pressurised
- M16x2 male test point included

Model Number	Main ports	Top ports	Flow Range (US gpm)	Maximum pressure (psi)
LT300R-FM-S-S-6	1-5/16" -12UN #16 SAE ORB	7/16" -20UN #4 SAE ORB	2 - 80	6000
LT400R-FM-S-S-6	1-5/16" -12UN #16 SAE ORB	7/16" -20UN #4 SAE ORB	2.5 - 100	6000
LT600R-FM-S-S-7	1-7/8" -12UN #24 SAE ORB	7/16" -20UN #4 SAE ORB	4 - 160 *	7000
LT800R-FM-S-S-7	1-7/8" -12UN #24 SAE ORB	7/16" -20UN #4 SAE ORB	5 - 210 *	7000

\* LT600/800R has limited pressure control below 23 US gpm (86 lpm). The maximum controllable pressure in this region is calculated by: max pressure (psi) = 289 x flow (gpm). For connecting cable/hoses see accessories section



## Complete hydraulic test kit to measure flow, pressure, and temperature under load

### DHCR-LT1500 kit

- Flow: Up to 400 US gpm
- Pressure: Up to 6000 psi
- Accuracy:  $\pm 1\%$  of indicated reading
- Fast checks on pumps, motors, valves, cylinders and hydrostatic transmissions.
- Remote Inputs: 2 Flow and Temperature, Pressure and Speed
- Economical low power consumption from standard battery. Automatic "Power Off" feature.
- Infra-red Phototachometer with 'On Target' indicator.
- Measures flow in both directions (Note: LT1500 is uni-directional when used with HV1500 kit)



### HV1500 kit

- Smooth progressive pressure control
- High tensile aluminium body rated at 6000 psi
- Connecting flange for use with DHCR-LT1500 kit included, with seals and bolts
- Pilot operated over pressure internal bypass valve
- Spare burst discs included
- Uni-directional

### DHCR-LT1500 kit

#### Contents

DHCR, LT1500, connecting hose and cable assembly, user manuals all housed in a rugged carry case.  
Case Dimensions: 626 x 492 x 350 (24.6 x 19.4 x 13.8)  
Total Weight (Inc Case): 24 kg (53 lbs)

#### Operating specification for all parts

Ambient temperature: 15 to 40 °C (59 to 104 °F)  
Ambient humidity: 10 to 95% RH  
Altitude: up to 2000m (6,500 feet)  
Oil temperature range: 15 to 90 °C (59 to 194 °F)  
Oil cleanliness: ISO 18/15/12 (NAS 6) or better  
Fluid type: Mineral oil only typically ISO 15 -68 oil  
Viscosity Range: 10 centi-stokes to 100 centi-stokes  
Max pressure: 420 bar (6,000 psi)  
Seals: Viton

#### DHCR

Inputs: 1 pressure, 1 speed, 2 flow and temperature  
Max pressure: 6000 psi  
Engineering units: (selectable)  
Flow: lpm, US gpm, l gpm  
Temperature: °C or °F  
Dimensions: 200 x 160 x 90 (7.8 x 6.3 x 3.5)  
Weight: 2.6 kg (5.7 lbs)  
See separate Bulletin for further information.

#### LT1500

Main ports: 2" #32 SAE Code 62 4-bolt flange  
Top ports: 7/16" -20UN #4 SAE ORB x 2  
Flow range: 13 to 400 gpm  
Accuracy\*: 1% of indicated reading over 15 to 100% of flow range. (Below 15% of flow range  $\pm 2.25$  lpm) \* When used with DHCR  
Dimensions: 260 x 140 x 100 (10 x 5.5 x 4)  
Weight: 10 kg (22 lbs)

#### Frequency Output

Frequency: 20 - 2000 Hz  
Impedance: 3700 Ohm +25% - 20%  
Inductance: 1 kHz: 1,55H +25% - 20%

#### Construction

High tensile aluminium block houses a six blade turbine rotating on a combination axial/radial needle roller bearing and alloy steel shaft.

#### Filtration

It is recommended that a 25 micron filter is installed in the hydraulic circuit prior to the flow meter.

### HV1500 kit

Dimensions in Millimetres (Inches)

#### Contents

HV1500 load valve, 2" #32 SAE Code 62 4-bolt flange Connector and fitting kit, user manual, all housed in a rugged carry case.  
Case Dimensions: 626 x 492 x 350 (24.6 x 19.4 x 13.8)  
Total Weight (Inc Case): 39 kg (86 lbs)

#### Specification

Controllable flow range: 100 - 1500 lpm (26 - 400 US gpm)  
Ports, load valve: 2" #32 SAE Code 62 4-bolt flange  
Ports, connector: 2" #32 SAE Code 62 4-bolt flange  
Dimensions: 300 x 250 x 140 (12 x 10 x 5.5)  
Weight: 28 kg (61.6 lbs)

#### Construction

Wetted parts:  
High tensile aluminium block, Steel 212A42 electroless nickel plated and alloy steel.

#### Ordering information

Description	Order code / model number
DHCR / LT1500 kit	DHCR1500K
HV1500 kit	HV1500K

## HV Series Loading Valves

### Standard Features:

- Flow: Up to 210 gpm
- Pressure: Up to 6000 psi
- Bi-directional loading
- **"INTERPASS"**™ internal safety protection system with replaceable burst discs



- Smooth progressive pressure control
- High tensile aluminium body rated at 6000 psi
- Easy to retro-fit

Model number	Flow range (US gpm)	Port one	Port two
HV200-S-N-6	50	1-1/16" -12UN #12 SAE ORB	1-1/16" -12UN #12 SAE ORB
HV400-S-N-6	100	1-5/16" -12UN #16 SAE ORB	1-5/16" -12UN #16 SAE ORB
HV800-S-N-6	210 *	1-7/8" -12UN #24 SAE ORB	1-7/8" -12UN #24 SAE ORB

\* Pressure control is limited below 23 US gpm (86 lpm). The maximum controllable pressure in this region is calculated by: max pressure (psi) = 289 x flow (gpm) +436.

## TH3 - Tachometer Probe

### Standard Features:

- Rugged design
- Narrow beam IRED
- Very high sensing speed



- Low power consumption
- Precision glass lens
- Wide range of accessories

Model number	Part number	Description
TH3	FT9251	Sensor with cable and 5 pin plug

### Accessories

Model number	Part number	Description
BA20	FT9351 FT1800	Magnetic base with 230 mm (9") flexible arm and sensor holder Reflective tape - 900mm long (36")

## Safety Burst Discs

Replacement Burst Discs (10 per Package)		
0 - 100 gpm Testers & Load Valves (300 / 400 models)		
Part Number	Color Code	Nominal Burst Pressure (psi)
FT10791-6	Red	6000
FT10791-5	Blue	5000
FT10791-4	Green	4000
FT10791-3	Yellow	3000
160 gpm & 200 gpm Testers (600 / 800 models)		
FT10792-7	Orange	7000
FT10792-6	Red	6000
FT10792-5	Blue	5000

Note: Two discs required per replacement

## Repair & Calibration Services

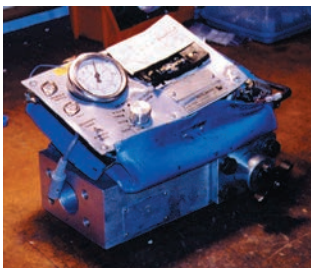

**We can repair it!**

### Description

- Certificate of Conformity, reissue
- Traceable flow test c/w data & graph
- Traceable pressure test c/w data & graph
- Operating manual, reissue
- HT series tester complete rebuild\* (1 year warranty)
- DHT series tester complete rebuild\* (1 year warranty)

Repairs quoted on a time & material basis

\* (Complete rebuilds include turbine assembly, load valve, pressure gauge, new electronics, user manual, labor, calibration and certificate of conformity)

**We offer calibration and repair services with traceable flow & pressure facilities for all products. We also offer Trade-Up discounts for obsolete or non-repairable models.**

## CT Series Turbine flow meters with conditioned output

### Standard Features:

- Flow: 0.25 - 400 US gpm
- Pressure: Up to 7000 psi
- Output Options: 4 - 20 mA, 0 - 5 V
- Bi-directional operation
- Fluids: Wide range of hydraulic oil, lubrication oils, and fuels



- Calibration: 21 cSt as standard. Special calibration possible
- Comprehensive range of accessories available including pressure transducers, temperature sensors panel meters and cables. See MPT, TP125 and DP130 bulletin for details or contact Webtec sales office

Model Number	Outputs available	Main ports	Top ports*	Flow range (US gpm)	Max. pressure (psi)
CT15-**-S-S-6	5V, mA	3/4" -16UN #8 SAE ORB	7/16" -20UN #4 SAE ORB	0.25 - 4	6000
CT60-**-S-S-6	5V, mA	1-1/16" -12UN #12 SAE ORB	7/16" -20UN #4 SAE ORB	0.8 - 16	6000
CT150-**-S-S-6	5V, mA	1-1/16" -12UN #12 SAE ORB	7/16" -20UN #4 SAE ORB	1.3 - 40	6000
CT300-**-S-S-6	5V, mA	1-5/16" -12UN #16 SAE ORB	7/16" -20UN #4 SAE ORB	2 - 80	6000
CT400-**-S-S-6	5V, mA	1-5/16" -12UN #16 SAE ORB	7/16" -20UN #4 SAE ORB	2.5 - 100	6000
CT600-**-S-S-5	5V, mA	1-5/8" -12UN #24 SAE ORB	7/16" -20UN #4 SAE ORB	4 - 160	5000
CT800-**-S-S-7	5V, mA	1-7/8" -12UN #24 SAE ORB	7/16" -20UN #4 SAE ORB	5 - 210	7000
CT800-**-F-S-3	5V, mA	1-1/2" #24 SAE Code 61 4-bolt flange	7/16" -20UN #4 SAE ORB	5 - 210	3000
CT800-**-F-B-6	mA	1-1/2" ~24 SAE Code 62 4-bolt flange	1/4" BSPP	20 - 800 lpm	420 bar
CT1500-**-F-S-6	5V, mA	1-1/2" #24 SAE Code 62 4-bolt flange	7/16" -20UN #4 SAE ORB	12.5 - 400	6000

Replace \*\* with mA or 5V to give complete model number. \*CT 15 has one of the specified top ports.

## CTR Series Turbine flow meters with conditioned output and built-in loading valve

### Standard Features:

- Flow: 2 - 210 US gpm
- Pressure: Up to 7000 psi
- Output Options: 4 - 20 mA, 0 - 5 V
- Loading Valve: with bi-directional flow and pressure loading capability \*
- "INTERPASS"™ safety disc system, bypasses oil internally in the event of the valve being over pressurised
- Fluids: Wide range of hydraulic oil, lubrication oils, and fuels



- Calibration: 21 cSt as standard. Special calibration possible
- Comprehensive range of accessories available including pressure transducers, temperature sensors panel meters and cables. See MPT, TP125 and DP130 bulletins for details or contact Webtec sales office

Model Number	Outputs available	Main ports	Top ports*	Flow range (US gpm)	Max. pressure (psi)
CT300R-**-S-S-6	5V, mA	1-5/16" -12UN #16 SAE ORB	7/16" -20UN #4 SAE ORB	2 - 80	6000
CT400R-**-S-S-6	5V, mA	1-5/16" -12UN #16 SAE ORB	7/16" -20UN #4 SAE ORB	2.5 - 100	6000
CT600R-**-F-S-3	5V, mA	1-1/2" #24 SAE Code 61 4-bolt flange	7/16" -20UN #4 SAE ORB	5 - 160	3000
CT800R-**-F-S-3	5V, mA	1-1/2" #24 SAE Code 61 4-bolt flange	7/16" -20UN #4 SAE ORB	5 - 210	3000
CT600R-**-S-S-7	5V, mA	1-7/8" -12UN #24 SAE ORB	7/16" -20UN #4 SAE ORB	4 - 160	7000
CT800R-**-S-S-7	5V, mA	1-7/8" -12UN #24 SAE ORB	7/16" -20UN #4 SAE ORB	5 - 210	7000

Replace \*\* with mA, PU, 5V to give complete model number.

CT600, 750, 800 has limited pressure control below 23 US gpm (86 lpm). The maximum controllable pressure in this region is calculated by: max pressure (psi) = 289 x flow (gpm) +436. For cables and connectors see next page.

## Compact Turbine Flowmeters

### Standard Features:

- Flow: 0.8 - 100 US gpm
- Pressure: Up to 6000 psi
- Accuracy: ± 1% of indicated reading over a wide range (depending on readout)
- Bi-Directional: operation



- Temperature: sensor built-in
- Fluids: Wide range of hydraulic, lubrication oil, and fuels
- Calibration: 21 cSt as standard. Special calibration possible

Model Number	Main ports	Top ports	Flow range (US gpm)	Max Pressure (psi)
LTE50-S-S-6	1-1/16" -12UN #12 SAE ORB	7/16" -20UN #4 SAE ORB	0.8 - 16	6000
LTE125-S-S-6	1-1/16" -12UN #12 SAE ORB	7/16" -20UN #4 SAE ORB	1.3 - 40	6000
LTE250-S-B-6	1-5/16" -12UN #16 SAE ORB	1/4" BSPP	2 - 80	6000
LTE400-S-B-6	1-5/16" -12UN #16 SAE ORB	1/4" BSPP	2.5 - 100	6000

# Gear Flowmeters

## GF Series Positive displacement flow meters with conditioned output

**Standard Features:**

- Flow: 0.1 - 150 lpm, 0.03 - 40 US gpm
- Pressure: up to 420 bar, 6000 psi.
- Output Options: 4-20 mA & pulse (both linearized)
- Bi-Directional operation



- Calibration: 21 cSt as standard. Special calibration possible. Calibration certificate supplied as standard.
- Fluids Oils, fuels, water glycol, water oil emulsions, phosphate esters.
- Stainless Steel Body, gears and transducer as standard.

Model number	Male Fitting	Flow range	Pressure
GF025-MAP-B-6	1/2" -14 BSPP	0.1 to 25 lpm	420 bar
GF025-MAP-S-6	3/4" -16UNF-2B JIC Male	0.03 to 7 US gpm	6000 psi
GF070-MAP-B-6	3/4" -14 BSPP	0.5 to 70 lpm	420 bar
GF070-MAP-S-6	1-1/16" 12UN-2B JIC Male	0.15 to 19 US gpm	6000 psi
GF150-MAP-B-6	3/4" BSPP	1 to 150 lpm	420 bar
GF150-MAP-S-6	1-1/16" -12UN-2B JIC Male	0.26 to 40 US gpm	6000 psi

## Cables and Connectors

**Model No.**

**Description**

- |   |   |
|---|---|
| <p>FT9880<br/>                 FT10228-05<br/>                 FT10541-06<br/>                 FT10521-06</p> | <p>Connector, M12 x 1 5 Pin, for use with CT and CTR flow meters (mA, 5V version), TP125, MPT and SP-TTL<br/>                 Cable, 16 ft. Use with LT, LTR, CT, CTR, TP125, MPT and SP-TTL. One M12 x1 connector included.<br/>                 Cable, Flow &amp; Temperature, 20 ft. to connect LT series flowmeter to portable tester remote input.<br/>                 Cable hose assembly, 20 ft, to connect LT to DHCR.</p> |
|---|---|

# Pressure Transducers

## MPT Series Low Cost Pressure Transducers

**Standard Features:**

- Accurate ( $\pm 0.25\%$  Full Scale)
- Economically priced
- Rugged design
- Output Options:  
4 - 20mA or 0 - 5V



- Stainless Steel wetted parts
- Connector: Male 4 pin M12 x1.0
- Two thread forms available

Model number	Outputs available	Pressure range (Gauge)	Pressure Connection
MPT200PU**	5V, mA	200 psi	7/16" -20UN #4 SAE ORB Male
MPT600PU**	5V, mA	600 psi	7/16" -20UN #4 SAE ORB Male
MPT1K5PU**	5V, mA	1500 psi	7/16" -20UN #4 SAE ORB Male
MPT4K0PU**	5V, mA	4000 psi	7/16" -20UN #4 SAE ORB Male
MPT6K0PU**	5V, mA	6000 psi	7/16" -20UN #4 SAE ORB Male
MPT7K5PU**	5V, mA	7500 psi	7/16" -20UN #4 SAE ORB Male
MPT10K0PU**	5V, mA	10000 psi	7/16" -20UN #4 SAE ORB Male
MPT3K0PU**	5V, mA	3000 psi	7/16" -20UN #4 SAE ORB Male

Replace \*\* with mA or 5V to give complete model number

## TP125 Temperature Transmitter

### Standard Features:

- Max. Temperature: 257 °F
- Pressure Rating: 7000 psi
- Material: Stainless Steel / Aluminium



- Connector: Male 5 pin M12 x1.0
- Output Options: 4 - 20mA or 0 - 5V
- Three thread forms available

Model number	Output type	Fluid connection
TP125-5V-N	3 wire 0 - 5V	1/4" NPTF
TP125-5V-S	3 wire 0 - 5V	7/16" -20UN #4 SAE ORB Male
TP125-mA-N	2 wire 4 - 20mA	1/4" NPTF
TP125-mA-S	2 wire 4 - 20mA	7/16" -20UN #4 SAE ORB Male

Note: All NPTF threads are to ANSI B1.20.3 -1976 Class 1. As stated in the standard it is recommended that "sealing is accomplished by the means of a sealant applied to the thread". NPT fittings may also be used to connect to NPTF ports (also with a sealant applied to the thread)

## HPM110 Digital Pressure Gauge

### Standard Features:

- Accurate ( $\pm 0.5\%$  Full Scale)
- Economically priced
- Rugged design



- Digital display with bar graph
- Stainless Steel wetted parts
- Peak Pressure 10 ms scan rate
- Back lit display

Model number	Max pressure (psi)	Overload pressure (psi)	Burst pressure (psi)	Thread
SR-HPM-110-UN-1500	1500	3000	6000	7/16" -20UN #4 SAE ORB Male
SR-HPM-110-UN-8700	8700	17400	31900	7/16" -20UN #4 SAE ORB Male

## Speed Sensors

### SP-TTL Speed Sensor

Magnetic speed pickup with conditioned output

### Standard Features:

- Wide range 1 - 2000 Hertz
- Steel and aluminium housing
- 0 - 5 volt square wave output



- Two lock nuts provide
- M12 5 pin connection

Model number	Output	Frequency range
SP-TTL	Pulse	1 - 2000 Hertz

For cables and connectors see previous page

# Digital Panel Mount Readouts

## APM

APM Advanced Panel Meters Digital process meters for analog sensors.

### Standard Features:

- Combined digital and bar graph display.
- USB port for custom user settings
- Warning flash backlight.
- 0.1% accuracy for voltage inputs and 0.01% accuracy for current inputs
- Less than 2.1" deep.
- Visibility:
- User-adjustable backlight brightness and colour (red, green, white).



- Wide viewing angle (horizontal and vertical).
- Custom annunciators.
- Programmable:
  - I Display Range (Both Min & Max values)
- Two independent alarm set-points.
- Two independent outputs or 4-20mA analog monitor outputs.

### Specification

Code	Input Type	Analog Outputs <sup>1</sup>	Reset Input for peak value <sup>2</sup>
APM-MA	4-20mA	2 x 4-20mA	Yes
APM-5V	0-5V	2 X 4-20mA	Yes

<sup>1</sup> Analog and digital outputs share the same terminals.

<sup>2</sup> Preconfigured to reset the peak value after 14 seconds

## CAN sensors for hydraulic system monitoring of flow, pressure and temperature on pumps, valves and hydrostatic transmissions

The CT turbine flow meter range with configurable CAN output is a convenient solution to measure flow and temperature in hydraulic systems. The flow meter can be installed anywhere in the hydraulic circuit for production testing, commissioning, development testing and analysis of control systems. With the addition of the manual loading valve on the CTR meters further test scenarios can be simulated and monitored such as pump efficiency.

Pressure sensors also with CAN capability are also available to compliment the CT Flow meters. With a pressure sensor all the fundamental parameters of a hydraulic system can be monitored in a single, compact unit with one cable supporting the CAN protocol.

### Standard Features:

#### Flowmeters

- Flow: 1-1500 lpm 0.25 - 400 US gpm
- Temperature signal via flow transducer connection
- Pressure: Up to 480 bar, 7000 psi
- Porting: BSPP or SAE  
Bi-directional operation
- Built-in loading valve optional
- Output: CAN compatible (configured to customer's specification, e.g. J1939, CAN open)



- Fluids: Wide range of hydraulic oil, lubrication oils, and fuels
- Calibration: 21 cSt as standard. Special calibration possible
- Pressure Transducers
  - Pressure transducers
  - Pressure: 0 to 1000 bar (0 - 14500 psi)

## HPM4000 Hydraulic data logger

### Standard Features:

- Complete range of sensors – pressure, flow, temperature, tachometer
- Intelligent digital sensors (CAN protocol) for easier wiring and auto configuration (HPM4030 only)
- Analog SR sensors with sensor recognition (HPM4020 only)



- Large 3.5” back-lit display for quick and easy readings
- IP67 rated for use in extreme conditions (HPM4030)
- Kits available with carry case, charger & 1 x pressure transducer.
- Supplied with with HPMComm version 7 - PC software

Model number	Inputs (Number and type of sensors)
SR-HPM-4020-05-0C	2 'SR' sensors – up to four channels
SR-HPM-4030-05-0C-CAN	3 Intelligent Digital (CAN) sensors – up to six channels

*Note: Some sensors, such as the PTT pressure transducers that include a temperature sensor built-in, are one sensor that uses two channels.*

## HPM540 Hydraulic data logger

### Standard Features:

- Digital Readout of Pressure, Temperature, Flow, Differential Pressure\* (\*requires two transducers of same range)
- Windows Compatible Software
- Accuracy: Pressure within 0.5% of full scale  
Flow within 1% of full scale.
- Pressure up to 9000 psi, peaks to 14,000 psi.



- Auto configuration / sensor recognition
- Analog SR sensors with Sensor Recognition
- Battery Powered standard 9 Volt battery. Optional rechargeable unit.
- Min / Max memory
- USB connection

Model number	Description
SR-HPM-540-05-0C	4 input readout / data logger with USB data output & Windows compatible analysis software

## HPM6000 Hydraulic data logger

### Standard Features:

- Complete range of sensors - pressure, flow, temperature, tachometer
- Intelligent digital sensors (CAN protocol) for easier wiring and auto configuration
- Analog sensor inputs (HPM6116, HPM6216) including HPM-SR range, mA, volts
- Internal storage for over 36 million readings - expandable to over 1 billion readings
- Logging interval of 1 ms to 24 hours



- Re-chargeable internal battery - mains charger included
- Full colour 5.7 inch display
- IP64 and rubberised case surround for protection in harsh environments
- Supplied with HPMComm version 7 - PC software
- Connectivity - USB Host, USB slave, Ethernet

Model number	Intelligent Digital inputs (CAN)	Analog input channel
SR-HPM-6016-05-0C-CAN	2 lines - max of 8 sensors per line, 16 sensors in total (up to 32 channels)	None
SR-HPM-6116-05-0C-CAN	2 lines - max of 8 sensors per line, 16 sensors in total (up to 32 channels)	3 SR sensors (up to 6 channels) 2 configurable auxiliary inputs
SR-HPM-6216-05-0C-CAN	2 lines - max of 8 sensors per line, 16 sensors in total (up to 32 channels)	6 SR sensors (up to 12 channels) 4 configurable auxiliary inputs

*Note: Some sensors, such as the PTT pressure transducers that include a temperature sensor built-in, are one sensor that uses two channels.*

## HPM sensor range overview

Check the type and number of sensors your unit can accommodate. Sensors with built in temperature only count as one sensor.

Base Units - Model number	SR inputs	Intelligent Digital inputs (CAN)		Auxiliary analog inputs	Total sensors
		Number of lines	Max sensors per line		
SR-HPM-4020-05-0C	2	0	0	0	2
SR-HPM-4030-05-0C-CAN	0	1	3	0	3
SR-HPM-540-05-0C	4	0	0	0	4
SR-HPM-6016-05-0C-CAN	None	2	8	0	16
SR-HPM-6116-05-0C-CAN	3	2	8	2	21
SR-HPM-6216-05-0C-CAN	6	2	8	4	26

### Standard Features:

#### Turbine Flowmeters

- Flow: 0.25 - 200 US gpm
- Pressure: Up to 7000 psi
- Porting: SAE, BI directional operation

#### Pressure transducers

- With and without temperature built in
- Pressure: -14.5 to 14500 psi
- Temperature: -13 - 221 °F

#### Turbine Flowmeters with loading valve

- Flow: 0.25 - 200 US gpm
- Pressure: Up to 7000 psi
- Porting: SAE
- BI directional operation
- "INTERPASS"™ safety system, bypasses oil internally in the event of valve being over pressurised

#### Accessories

- Cables: 0.5 to 20 meter long

### Turbine Flowmeters

Model Number	Main ports	Top ports*	Flow range	Max. pressure
CT15-***-B-B-6	1/2" BSPP	1/4" BSPP	1 - 15 lpm	420 bar
CT15-***-S-S-6	3/4" -16UN #8 SAE ORB	7/16" -20UN #4 SAE ORB	0.25 - 4 US gpm	6000 psi
CT60-***-B-B-6	3/4" BSPP	1/4" BSPP	3 - 60 lpm	420 bar
CT60-***-S-S-6	1-1/16" -12UN #12 SAE ORB	7/16" -20UN #4 SAE ORB	0.8 - 16 US gpm	6000 psi
CT150-***-B-B-6	3/4" BSPP	1/4" BSPP	5 - 150 lpm	420 bar
CT150-***-S-S-6	1-1/16" -12UN #12 SAE ORB	7/16" -20UN #4 SAE ORB	1.3 - 40 US gpm	6000 psi
CT300-***-B-B-6	1" BSPP	1/4" BSPP	8 - 300 lpm	420 bar
CT300-***-S-S-6	1-5/16" -12UN #16 SAE ORB	7/16" -20UN #4 SAE ORB	2 - 80 US gpm	6000 psi
CT600-***-B-B-5	1-1/4" BSPP	1/4" BSPP	15 - 600 lpm	350 bar
CT600-***-S-S-5	1-5/8" -12UN #24 SAE ORB	7/16" -20UN #4 SAE ORB	4 - 160 US gpm	5000 psi
CT750-***-S-B-7	1-7/8" -12UN #24 SAE ORB	1/4" BSPP	20 - 750 lpm	480 bar
CT750-***-S-S-7	1-7/8" -12UN #24 SAE ORB	7/16" -20UN #4 SAE ORB	5 - 200 US gpm	7000 psi
CT750-SR-F-B-3 SR	1-1/2" #24 SAE Code 61 4-bolt flange	1/4" BSPP	20 - 750 lpm	210 bar
CT750-SR-F-S-3 SR	1-1/2" #24 SAE Code 61 4-bolt flange	7/16" -20UN #4 SAE ORB	5 - 200 US gpm	3000 psi

Replace \*\*\* with CAN or SR to give complete model number. \*CT 15 has one of the specified top ports.

### Turbine Flowmeters with loading valve

Model Number	Main ports	Top ports	Flow range	Max. pressure
CT300R-***-B-B-6	1" BSPP	1/4" BSPP	8 - 300 lpm	420 bar
CT300R-***-S-S-6	1-5/16" -12UN #16 SAE ORB	7/16" -20UN #4 SAE ORB	2 - 80 US gpm	6000 psi
CT600R-SR-F-B-3	1-1/2" #24 SAE Code 61 4-bolt flange	1/4" BSPP	20 - 600 lpm	210 bar
CT600R-SR-F-S-3	1-1/2" #24 SAE Code 61 4-bolt flange	7/16" -20UN #4 SAE ORB	5 - 160 US gpm	3000 psi
CT600R-SR-S-B-7	1-7/8" -12UN #24 SAE ORB	1/4" BSPP	20 - 600 lpm	480 bar
CT600R-SR-S-S-7	1-7/8" -12UN #24 SAE ORB	7/16" -20UN #4 SAE ORB	5 - 160 US gpm	7000 psi
CT750R-***-S-B-7	1-7/8" -12UN #24 SAE ORB	1/4" BSPP	20 - 750 lpm	480 bar
CT750R-***-S-S-7	1-7/8" -12UN #24 SAE ORB	7/16" -20UN #4 SAE ORB	5 - 200 US gpm	7000 psi
CT750R-SR-F-B-3	1-1/2" #24 SAE Code 61 4-bolt flange	1/4" BSPP	20 - 750 lpm	210 bar
CT750R-SR-F-S-3	1-1/2" #24 SAE Code 61 4-bolt flange	7/16" -20UN #4 SAE ORB	5 - 200 US gpm	3000 psi

Replace \*\*\* with CAN or SR to give complete model number.

**Positive displacement flow meters with Intelligent digital sensors (CAN protocol) coming in 2016. Please contact the sales office for further information.**



## Pressure Transducers

### CAN (ID)

Model Number	Pressure range
SR-PT*-016-05-0C-CAN	-1 - 16 bar
SR-PT*-060-05-0C-CAN	0 - 60 bar
SR-PT*-160-05-0C-CAN	0 - 160 bar
SR-PT*-400-05-0C-CAN	0 - 400 bar
SR-PT*-600-05-0C-CAN	0 - 600 bar
SR-PT*-1K0-05-0C-CAN	0 - 1000 bar

### SR

Model Number	Pressure range
SR-PT*-015-05-0C	-1 - 15 bar
SR-PT*-060-05-0C	0 - 60 bar
SR-PT*-150-05-0C	0 - 150 bar
SR-PT*-400-05-0C	0 - 400 bar
SR-PT*-600-05-0C	0 - 600 bar
SR-PT*-1K0-05-0C	0 - 1000 bar

Replace \* with 'N' for no temperature and with 'T' for unit with temperature. Supplied with M16 x 2 test point connector

#### SR-PTN-\*\*\*-0C-CAN

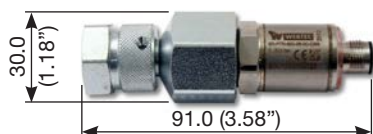

#### SR-PTN-\*\*\*-05-0C

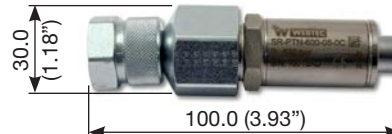

#### SR-PTT-\*\*\*-0C-CAN



#### SR-PTT-\*\*\*-05-0C



### Functional specification

<b>Ambient temperature:</b>	-25 to 85 °C (-13 - 185 °F)
<b>Fluid type:</b>	Oils, fuels, water glycol, water oil emulsions
<b>Fluid temperature:</b>	-25 to 105 °C (-13 - 221 °F)
<b>Accuracy:</b>	Pressure: ± 0.5% full scale Temperature: ± 3 °C (SR-PTT-* ONLY)

### Electrical specification

<b>Power supply:</b>	CAN: 8 - 40 VDC SR: 7-15 VDC SR
<b>Response Time:</b>	1 ms

### Construction material

<b>Main body:</b>	Stainless steel 1.4301
<b>Sealing:</b>	Viton® (FKM)
<b>Degree of protection*:</b>	SR - IP54 (EN60529) CAN - IP66 (EN60529) *With cable connected

**Wetted parts:** Stainless steel 1.4301, Viton® (FKM)

**Dimensions:** 95.6 mm x 26.9 mm

**Weight approx.:** 170 g

### CAN (ID) Connection cables

Model Number	Length
SR-CBL-0.5-MF-CAN	0.5m
SR-CBL-02-MF-CAN	2m
SR-CBL-05-MF-CAN	5m
SR-CBL-10-MF-CAN	10m
SR-CBL-20-MF-CAN	20m
SR-CBL-0.05-Y-CAN	Splitter no cable
SR-CBL-0.3-Y-CAN	CAN Y splitter, including 0.3 m cable
SR-CBL-000-R-CAN	CAN terminating resistor
SR-CONN-ADPT-M8	Cable adapter M8x1 4pol Digital IN/OUT
SR-CONN-ADPT-M12	Cable adapter M12x1 5pol analog

### Accessories / spares

Model Number	Description
SR-PSU-HPM6000	HPM6000 power pack
SR-HPM6000-00-0C-STP	HPM6000 neck strap
SR-CAB-540-PC-USB	HPM540 PC Cable to USB
SR-USB-HPM6000	USB cable type A to B
SR-LAN-HPM6000	LAN cable
SR-HPM-PSU-MC-1C	Power supply for HPM540
SR-HPM-CHG-03-0C	In car charger adaptor
SR-HAND-HPM6000	Replacement handle for HPM6000

### SR Cables

Model Number	Length	Type
SR-CBL-003-55-MM	3m	Connecting
SR-CBL-005-55-MF	5m	Extension
SR-CBL-002-54-MM	2m	Adaptor 5 to 4 pin

### Other sensors & accessories

Model Number	Description
SR-RPM-300-05-3C	SR Tach with 5 pin fixed cable
SR-RPM-WHL-00-0C	Tach contact wheel
SR-RPM-ADP-00-0C	Focus adaptor
SR-EXT-TRG-05-1C	External trigger box
SR-VADC-700	SR/CAN voltage, current & frequency converter
SR-TTP-190-05-0C	SR Temperature transducer -40 to 150 °C 1/4" BSPP
SR-TTP-190-05-0C-CAN	CAN Temperature transducer -40 to 150 °C 1/4" BSPP
SR-ICM*	ICM Contamination Monitor Kit for HPM6000

\* Only NAS code is transmitted to the HPM6000 as standard.  
Other options available - please consult sales office.

# C2000 Hydraulic data acquisition system

## A complete hydraulic solution to provide professional test certificates for your customers

The C2000 is a 3rd generation solution for displaying, logging and reporting hydraulic test information, designed for use on pump test stands.

The C2000 offers the latest in data monitoring and logging capability. The super panel offers easy user configuration of up to 12 channels in either digital or slider mode.

### Standard Features:

- Modular 8 - 64 inputs
- Windows™ compatible Software
- Hydraulic test solution



- Print test Certificates
- TCP/IP network ready
- Dedicated high-speed controller

### Receive a pump . . .



Receive the pump (or other hydraulic component) from your customer

### Check on-screen values . . .



Following repair, run oil through the pump and display real-time hydraulic values (Flow, pressure, temperature, speed plus custom measurements)

### Record test data



Using your own test procedure you can display real time values and record test results on a keypress

### Print your certificate



Print the test certificate at the touch of a button, ready to send back to the customer with the pump.

### Features:

- Up to 64 channels

### Sensors available:

- Flow meters 0.25 to 400 gpm
- Pressure transducers 15 to 15000 psi
- Temperature transducer 32 to 257°F
- Speed sensor
- Fluid ISO particle count
- Standard 4 - 20 mA or TTL inputs for additional sensors

### Three logging modes:

- Log on a keypress
- Profile logging
- Continuous logging
- Logging speed up to 2 kHz per channel
- Over 8 million readings capability

### Four monitoring screens:

- Super panel
- Two standard panels
- Real time graphing
- User defined screen layouts & calculated channels

### Other:

- Analysis of results
- Ethernet connection
- Industrial control unit included as standard
- Optional 19" rack
- Help on line
- Export files to other packages
- Easy upgrade path for future expansion if needed

### C2000 mid-box

Up to 5 modules as standard 5U height  
Expansion box adds up to an additional 3 modules 4U height

### Input signal type

4 - 20 mA signals - measurement 8 channels per module  
TTL - frequency measurement - 6 channels per module

## FI750 Series In-Line Flow Indicator

### Standard Features:

- Flow: 0.5 - 48 US gpm
- Pressure: 6000 psi
- Accuracy within 4% FSD
- Built-In thermometer available
- Direct reading
- Dual scale lpm/US gpm



- Horizontal or vertical mounting
- Large clear dial
- Low cost rugged design
- Pressure gauge port
- Wide operating range

Model Number with temperature	Model number without temperature	Calibrated flow range (US gpm)	Main ports	Top port	Max. pressure (psi)
FI750-16ANOT	FI750-16ANO	0.5 - 4	3/4" NPSF	1/4" NPTF	6000
FI750-30ANOT	FI750-30ANO	0.5 - 8	3/4" NPSF	1/4" NPTF	6000
FI750-60ANOT	FI750-60ANO	0.5 - 16	3/4" NPSF	1/4" NPTF	6000
FI750-120ANOT	FI750-120ANO	1 - 32	3/4" NPSF	1/4" NPTF	6000
FI750-180ANOT	FI750-180ANO	4 - 48	3/4" NPSF	1/4" NPTF	6000
FI750-16ASOT	FI750-16ASO	0.5 - 4	1 - 1/16" - 12 UNF #12 SAE ORB	1/4" NPTF	6000
FI750-30ASOT	FI750-30ASO	0.5 - 8	1 - 1/16" - 12 UNF #12 SAE ORB	1/4" NPTF	6000
FI750-60ASOT	FI750-60ASO	0.5 - 16	1 - 1/16" - 12 UNF #12 SAE ORB	1/4" NPTF	6000
FI750-120ASOT	FI750-120ASO	1 - 32	1 - 1/16" - 12 UNF #12 SAE ORB	1/4" NPTF	6000
FI750-180ASOT	FI750-180ASO	4 - 48	1 - 1/16" - 12 UNF #12 SAE ORB	1/4" NPTF	6000

## FI750/1500 Series Brass In-Line Flow Indicator

### Standard Features:

- Flow: 0.5 - 100 US gpm
- Pressure: 6000 psi
- Accuracy within 4% FSD
- Built-In thermometer available
- Direct reading
- Dual scale water/oil



- Horizontal or vertical mounting
- Large clear dial
- Low cost rugged design
- Pressure gauge port
- Wide operating range

Model Number with temperature	Model number without temperature	Calibrated flow range (US gpm)		Main ports	Top port	Max. pressure (psi)
		Water	Oil			
FI750-30BNWT	FI750-30BNW	0.5 - 8	0.5 - 8	3/4" NPSF	1/4" NPTF	6000
FI750-60BNWT	FI750-60BNW	0.8 - 8	0.5 - 16	3/4" NPSF	1/4" NPTF	6000
FI750-120BNWT	FI750-120BNW	1 - 37	1 - 32	3/4" NPSF	1/4" NPTF	6000
FI1500-200BSWT	FI1500-200BSW	2.5 - 50	2.5 - 50	1-7/8" -12UN #24 SAE ORB	1/4" NPTF	5000
FI1500-400BSWT	FI1500-400BSW	5 - 100	5 - 100	1-7/8" -12UN #24 SAE ORB	1/4" NPTF	5000

## FI1500 Series In-Line Flow Indicator

### Standard Features:

- Flow: 0.5 - 100 US gpm
- Pressure: 6000 psi
- Accuracy within 4% FSD
- Built-In thermometer available
- Direct reading
- Dual scale lpm/US gpm



- Horizontal or vertical mounting
- Large clear dial
- Low cost rugged design
- Pressure gauge port
- Wide operating range

Model Number with temperature	Model number without temperature	Calibrated flow range (US gpm)	Main ports	Top port	Max. pressure (psi)
FI1500-200ASOT	FI1500-200ASO	5 - 50	1-7/8" -12UN #24 SAE ORB	1/4" NPTF	5000
FI1500-300ASOT	FI1500-300ASO	4 - 80	1-7/8" -12UN #24 SAE ORB	1/4" NPTF	5000
FI1500-400ASOT	FI1500-400ASO	5 - 100	1-7/8" -12UN #24 SAE ORB	1/4" NPTF	5000

## Flow and temperature: Measure, display, switch, transmit

### Standard Features:

- Flow: 0.25 - 100 US gpm
- Pressure: 6,000 psi
- Designed for permanent installation (few wearing parts)
- Easy to operate: 4 digit LED display, 3 large keys
- Accuracy better than 3% FSD
- Repeatability better than 1%
- Temperature measurement built-in



- Wide range of options: Choice of outputs V or mA. Two programmable switches. Complete with adaptors fitted (BSP or JIC Male). Engineering units lpm or US gpm (°C or °F)
- Easy installation: Mount in any orientation, Install straight after a bend
- Allows reverse flow
- Traceable calibration on request

### Model configuration

#### Example

HF100 - TRNMA-3 - S100V  
Code 1                      Code 2                      Code 3

Above model number is a FlowHUB Transmitter: Flow range: 2 - 100 US gpm, Maximum pressure: 3000 psi (210 bar), Temperature: °F, Output: 4 - 20 mA, no switches, 1 5/16" JIC Male adaptors.

### Step 1 - Choose flow range and engineering units

EU flow range (lpm)			US flow range (US gpm)		
Code 1	Flow range	Standard adaptors	Code 1	Flow Range	Standard adaptors
HF030	1 - 30	1/2" or 3/4" BSPP	HF008	0.3 - 8	1-1/16" -12UN JIC Male or 3/4" -16UN JIC Male
HF060	2 - 60	1/2" or 3/4" BSPP	HF016	0.5 - 16	1-1/16" -12UN JIC Male or 3/4" -16UN JIC Male
HF120	4 - 120	3/4" or 1" BSPP	HF032	1 - 32	1-1/16" -12UN JIC Male or 1-5/16" -12UN JIC Male
HF240	8 - 240	1" BSPP	HF064	2 - 64	1-5/16" -12UN JIC Male
HF360	8 - 360	1" BSPP	HF100	2 - 100	1-5/16" -12UN JIC Male

### Step 2 - Choose electronics and maximum pressure

Electronic control and maximum pressure options		
Code 2	Maximum working pressure (psi)	Function description
SWTNA-3	3,000	Two programmable switches
TRN5V-3	3,000	Output 0 - 5 Volt
TRNMA-3	3,000	Output 4 - 20 mA
ULT5V-6	6,000	Two programmable switches, output 0 - 5 Volt
ULTMA-6	6,000	Two programmable switches, output 4 - 20 mA

### Step 3 - Choose adaptors

Adaptors			
BSPP options		SAE options	
Code 3	Description	Code 3	Description
B050V	1/2" BSPP	S050V	3/4" -16UN JIC Male
B075V	3/4" BSPP	S075V	1-1/16" -12UN JIC Male
B100V	1" BSPP	S100V	1-5/16" -12UN JIC Male

Custom configurations are available, please contact sales.

### Build your own FlowHUB

-  -   
Code 1                      Code 2                      Code 3

Order connecting cable separately - contact sales office

# WP Series Low Cost In-Line Flowmeters

## Standard Features:

- Advanced sharp edge orifice design provides measurement stability over wide viscosity range
- Reliable and economical design
- Direct reading, dual calibrated scale, gpm/lpm, special scales available.
- Available in Aluminium, Brass or Stainless Steel to suit fluid
- Line sizes 1/2", 3/4", 1", 1-1/2" & 2"
- Flowrates available; 0.05 to 150 gpm - liquids. 1.5 - 1350 SCFM - gases
- Max pressure rating 3500 & 6000 psi liquids, 1000 psi gases.



- Accurate within 2% FSD
- Ports available in SAE, NPT or BSP
- Optional single or dual flow switch, high temperature versions, transmitter version and phosphate ester models.
- Unrestricted mounting in any orientation, horizontal, vertical or inverted.
- High strength cast ALNICO magnet for superior coupling performance
- Available with free reverse flow or bidirectional reading

## Product Selector

Standard Flow Meter Part Number (For custom units, consult the Sales Office)

Series # WP    -    -   Webtec Part Number

Step 1 - Style	
BASIC in line for liquid	= B
Pneumatic for air and gas	= G
High Temp 400 °F (200 °C)	= H
Flow alarm, 1 switch	= M
Flow alarm, 2 switches	= N
Flow transmitter	= R
Phosphate esters	= P

Step 2 - Port / Line Size	
1/4" - 1/2"	= 3
3/4" - 1"	= 4
1 1/4" - 2"	= 5

Step 3 - Material	
Aluminium	= A
Brass	= B
Stainless Steel	= S

Step 4 - Pressure rating maximum	
600 psi (Air and gas / Aluminium and brass)	= 4
1000 psi (Air and gas / Stainless steel)	= 5
3500 psi (Liquids / Aluminium and brass)	= 6
6000 psi (Liquids / Stainless steel)	= 7

Step 5 - Fluid	
Air and Gases	= A
Oil and 0.873 specific gravity	= H
Water and 1.0 specific gravity	= W

Step 6 - Thread porting	
<b>Size 3 available threads</b>	
1/4" NPTF	= S
3/8" NPTF	= A
1/2" NPTF	= B
9/16" -18UN #6 SAE ORB	= E
3/4" -16UN #8 SAE ORB	= F
7/8" -14UN #10 SAE ORB	= G
3/8" BSPP	= R
1/2" BSPP	= T
<b>Size 4 available threads</b>	
3/4" NPTF	= C
1" NPTF	= D
1-1/16" -12UN #12 SAE ORB	= H
1-5/16" -12UN #16 SAE ORB	= J
3/4" BSPP	= U
1" BSPP	= V
<b>Size 5 available threads</b>	
1-1/4" NPTF	= K
1-1/2" NPTF	= L
2" NPTF	= M
1-5/8" -12UN #20 SAE ORB	= N
1-7/8" -12UN #24 SAE ORB	= P
2" -12UN #32 SAE ORB	= Q
1-1/4" BSPP	= W
1-1/2" BSPP	= Y
2" BSPP	= X

Please note - SAE porting not available in brass

Step 7 - Flow ranges			
Oil and Water	@100 PSIG		
lpm (US gpm)	SCFM		Size
0.5 - 4 (0.05 - 1)	1.5 -12	= 01	3 only
0.5 - 4 (0.1 - 1) water			
1 - 8 (0.2 - 2)	4 - 23	= 02	3 & 4
2 - 19 (0.5 - 5)	5 - 50	= 05	3 & 4
4 - 38 (1 - 10)	10 - 100	= 10	3 & 4
4 - 56 (1 - 15)	25 - 150	= 15	3 & 4
10 - 75 (2 - 20)	20 - 215	= 20	4 only
10 - 100 (2 - 25)	20 - 250	= 25	4 & 5
10 - 115 (3 - 30)	30 - 330	= 30	4 only
15 - 150 (4 - 40)	30 - 400	= 40	4 only
15 - 190 (5 - 50)	40 - 500	= 50	4 only
15 - 190 (5 - 50)	30 - 470	= 50	5 only
30 - 280 (8 - 75)	30 - 750	= 75	5 only
40 - 375 (10 - 100)	150 - 900	= 88	5 only
75 - 550 (20 - 150)	150 - 1300	= 99	5 only

Step 8 - Optional flow directions	
Uni-directional	=
Bi directional	= BI
Reverse flow	= RF

Bi-directional option not available for Pneumatic (G), Alarm (M&N), Transmitter (R).

Bi-directional option only available in the following flow ranges:

- Size code 3 - flow range 5,10 and 15 gpm only
- Size code 4 - flow range 10,15, 20 and 30 gpm only
- Size code 5 - flow range 50, 75 and 100 gpm only

## Lower Cost Case Drain Monitor

Series # WPC   -    -   Webtec Part Number

Port / Line Size	
1/2"	= 3
3/4" - 1"	= 4

Material	
Aluminium	= A

Pressure Rating Max.	
1000 psi	= 5

Fluid Media	
Oil and 0.873 specific gravity	= H
Water and 1.0 specific gravity	= W

Thread Type	
Porting (All Female)	Size
1/2" BSPP	= T 3 only
3/4" BSPP	= U 4 only
1" BSPP	= V 4 only
1/2" NPTF, dry seal	= B 3 only
3/4" NPTF, dry seal	= C 4 only
1" NPTF, dry seal	= D 4 only

Flow ranges (oil and water)		
lpm (US gpm)		Size
0.5 - 4 (0.1 - 1)	= 01	3 only
1 - 8 (0.2 - 2)	= 02	3 & 4
2 - 19 (0.5 - 5)	= 05	3 & 4
4 - 38 (1 - 10)	= 10	3 & 4
4 - 56 (1 - 15)	= 15	3 & 4
10 - 75 (2 - 20)	= 20	4 only
10 - 100 (2 - 25)	= 25	4 & 5
10 - 115 (3 - 30)	= 30	4 only

## Fully customizable Pressure Test Kits

### Standard Features:

- Custom built to your specification - pick and mix from huge range.
- Pressure Test Kits provide a complete test system for rapid pressure testing.
- Pressure test points can be fitted anywhere in the circuit for instant pressure checks saving installation costs of piping and gauges.
- Test hoses can be connected by hand under full system pressure without loss of oil or ingress of dirt. Oil samples can be taken and circuits bled of air.



- The kit includes gauges, hoses, test points and adaptors.
- The case provides ample storage and the gauge panel can be removed for convenient use while testing the machine. (PT4 and PT6 only)
- Three models available - completely assembled`

	Model No.	Contents
	PT200-2	Rugged Plastic case 2 gauges from table 1 1 hose 2 meters long from table 2 2 test points from table 3 2 adaptors from table 4
	PT100-4	Metal Case - removable gauge panel 4 gauges from table 1 2 hoses 2 meters long from table 2 4 test points from table 3 4 adaptors from table 4
	PT100-6	Metal Case - removable gauge panel 6 gauges from table 1 6 hoses 2 meters long from table 2 6 test points from table 3 4 adaptors from table 4
	PT200-8	Compact case 8 gauges from table 1 (complete with rubber cover) 3 hoses 2 meters long from table 2 7 test points from table 3 2 adaptors from table 4

**See Contents tables on next page**

Test kits can be modified or assembled to your specifications, Please contact sales office

# Pressure Test Kit Contents Tables

## Order specification sheet

### Choose kit type

Kit	Part Number	No. reqd
PT200-2	FT9213	
PT100-4	FT5823	
PT100-6	FT7915	
PT200-8	FT10278	

### PT200-2 Contents

#### Compact case

2 gauges from table 1  
1 hose 2 meters long from table 2  
1 test point from table 3  
2 adaptors from table 4

### PT100-4 Contents

#### Metal Case - removable gauge panel

4 gauges from table 1  
2 hoses 2 meters long from table 2  
4 test points from table 3  
4 adaptors from table 4

### PT100-6 Contents

#### Metal Case - removable gauge panel

6 gauges from table 1  
6 hoses 2 meters long from table 2  
6 test points from table 3  
4 adaptors from table 4

### PT200-8 Contents

#### Compact case

8 gauges from table 1 (with rubber cover)  
3 hoses 2 meters long from table 2  
7 test points from table 3  
2 adaptors from table 4

**Table 1 - Pressure Gauges**

Glycerine filled, scale in both bar and psi

Pressure range: bar (psi)	Part number	No. reqd
0 - 10 (0 - 140)	FT5274-1	
0 - 20 (0 - 290)	FT5274-2	
0 - 40 (0 - 580)	FT5274-3	
0 - 70 (0 - 1000)	FT5274-6	
0 - 140 (0 - 2000)	FT5274-5	
0 - 200 (0 - 2900)	FT5274-7	
0 - 280 (0 - 4000)	FT5274-8	
0 - 400 (0 - 5800)	FT5274-4	



**Table 2 - High pressure hoses**

Pressure rating 420 bar (6000 psi) at 50 °C.  
Minimum bend radius 18mm.

Length 'L' mm (inches)	Part number	No. reqd
300 (12)	FT9128-030	
1000 (39)	FT9128-100	
2000 (78)	FT9128-200	
2500 (98)	FT9128-250	
4000 (157)	FT9128-400	

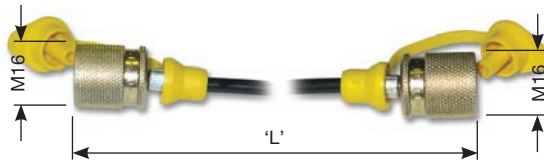

**Table 3 - Pressure test points, Pressure rating 400 bar max.**

Thread G	L1	AF	Part number	No. reqd
1/8" BSPT	36	17	8172675	
1/8" BSPP	37	17	8172671	
1/4" BSPT	36	17	8172676	
1/4" BSPP	40	19	FT9742-1	
M8 x1	38	17	8172666	
M10 x1	38	17	8172667	
M12 x 1.5	40	17	8172668	
M14 x 1.5	40	19	8172669	
M16 x 1.5	37	22	8172670	
7/16" -20UN #4 SAE ORB	38	17	FT9738-1	
1/8" NPT	38	17	8112618	
1/4" NPT	40	17	8172677	
9/16" -18UN #6 SAE ORB	40	19	8172678	
1/2" -20UN #5 SAE ORB	37	17	FT6777	

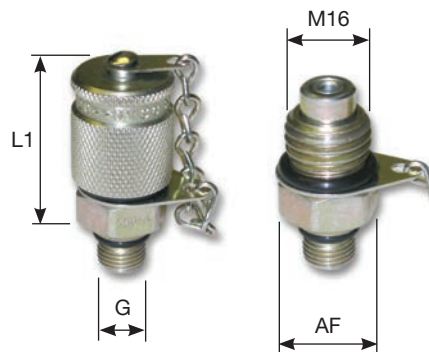

**Table 4 - Adaptor fittings**

Thread G	L1	L2	AF	Part number	No. reqd
3/8" BSPP	25	12	25	FT1609	
1/2" BSPP	27	10	25	FT2771	
3/4" BSPP	32	10	32	FT5305	
M18 x 1.5	27	12	25	FT5306	
9/16" -18UN JIC Male	28	15	19	FT1607	
3/4" -16UN JIC Male	25	8	25	FT1606	
7/8" -14UN JIC Male	31	10	25	FT1605	

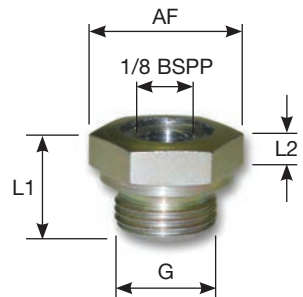

### Options

Coupling to connect two hoses: Part number 8173667  
Spare gauge connectors: Part number 8112625

Other gauge connectors available  
consult sales for information

# Custom hydraulic test kits

If you are using diagnostic test equipment, there is a very high chance that you will be using it for field service, wherever that may be. It is important that when you get on site, the equipment is easily and quickly accessible and ready to use.

In response to customer demand, Webtec offers individual kits to store and easily transport your hydraulic test equipment on-site. So, now rather than having several separate boxes to carry you can have a dedicated kit to

manage the transport of your test equipment using the internationally renowned Pelican™ case system.

The Pelican™ cases are rugged, durable, waterproof and airline approved, ensuring that you arrive on-site with your Webtec test equipment intact and ready to use, no matter what the conditions. On the larger Pelican™ cases, a set of wheels and a carry handle are also included for even easier transportation.

**Standard Features:**

- Customised kits for your needs
- Easy to transport
- Rugged, durable, waterproof and airline approved.



- Renowned and internationally recognised Pelican™ case brand
- Wheels and carry handle on larger cases



Standard DHCR kit with high density foam



Custom and branded kits also available

# Custom hydraulic components

## Hydraulic solutions designed to your specification

Give your machine the edge over your competitors. Working with you and your team Webtec will research, develop, test and manufacture a special hydraulic solution that can include many different components.

Typical applications are on mobile machinery used in the Construction, Mining, Agricultural or Energy industries and benefits include:

**Standard Features:**

- Combination flow / pressure / directional control monoblock valves to reduce envelope size, piping and assembly costs
- Custom high-efficiency flow control valves to reduce energy wastage and prevent overheating
- Real-time hydraulic system monitoring of flow, pressure, temperature and contamination to reduce down time or warranty claims





## ILFC Series In-Line Fixed Flow Control

Flow Control Valves maintain the flow rate of hydraulic fluid to a specified value.

### Features:

- Pressure compensated to ensure a constant flow rate under varying pressures.
- Pre-set in factory to customer requirements at any flow rate between 0.4 to 4.2 gpm.
- Uncontrolled flow is permitted in reverse direction.



- Zinc plated clear passivate.
- Cartridge version available, without steel body.

**Flow Ranges:** 0.4 - 3.7 gpm (1/4" ports), 0.4 - 4.2 gpm (3/8" ports)

**Maximum Pressure:** 3000 psi

**Ports:** BSPP, NPTF & SAE

## VFC Series Variable flow pressure compensated control valve

Variable Flow Control Valves maintain the flow rate of hydraulic fluid to a selected value.

### Features:

- Pressure compensated to ensure a constant flow rate under varying pressures.
- Knurled knob enables fast, accurate adjustment of flow rate in one direction (under pressure)
- Knurled knob can be locked in position by a grub (set) screw and provides weatherproof sealing to prevent the adjusting screw from corroding or seizing.

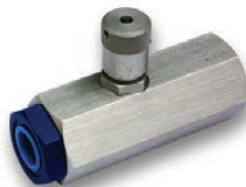

- Free (uncontrolled) flow is permitted in reverse direction.
- Special, Uni-directional version available on request.

**Flow Ranges:** 0.4 - 5.2 gpm (1/4" ports), 0.5 - 10 gpm (3/8" ports), 0.5 - 14.5 gpm (1/2" ports)

**Maximum Pressure:** 3000 psi

**Ports:** BSPP, NPTF & SAE

## FV120 Series Fixed Priority Flow Dividers

Priority Type Flow Dividers split a single input flow into a 'Priority' (regulated) flow and a 'By-Pass' (excess) flow which can be returned directly to the oil reservoir or used to

power a second system. This often dispenses with the need for another pump to operate a second system.

### Features:

- 'Priority' flow rate is preset in factory to customer specifications at any value between 3.78 lpm and 34.1 lpm in increments of 3.78 lpm. Flow through the 'Priority' port will remain constant at the pre-set value as long as input flow equals or exceeds the Priority flow value.



- Pressure compensated permitting both 'Priority' and 'By-Pass' flows to be used simultaneously at varying pressures without effecting the 'Priority' flow rate.
- Optional built-in pressure relief valve protects the 'Priority' circuit from excess pressure and is adjustable from 34.5 bar to 210 bar (Factory set 82.7 bar unless otherwise specified).

**Total Flow Capacity:** 20 gpm

**Maximum Pressure:** Up to 6000 psi

**Ports:** BSPP, NPTF & SAE

## FV200 Series Proportional Flow Dividers

Proportional Flow Dividers split a single input flow into two output flows, each output being a fixed proportion of the input. For example, a 50/50 flow divider will always split a single input flow into two equal output flows which could

be used to operate two motors at equal speeds. The actual rate of flow from each output is not fixed but will vary as the input flow rate varies.

### Features:

- Pressure compensated to keep each output flow at a fixed percentage of the input flow, regardless of pressure variations between the output ports.



- Standard proportional splits are available (see ordering codes). Other non-standard proportional splits are available upon request.
- Four Input flow ranges are available

**Total Flow Capacity:** 20 gpm

**Maximum Pressure:** Up to 6000 psi

**Ports:** BSPP, NPTF & SAE

## VFD50 Series Variable Priority Flow Divider

Priority Type Flow Dividers split a single input flow into a 'Priority' (regulated) flow and a 'By-Pass' (excess) flow which can be returned directly to the oil reservoir or used to

power a second system. In many instances this dispenses with the need for another pump to operate a second system.

### Features:

- Clearly marked hand-dial permits fast visual adjustments to pre-determined 'Priority' flow and fast easy adjustment of 'Priority' circuit to meet varying requirements.



- Pressure compensated permitting both 'Priority' and 'By-Pass' flows to be used simultaneously at varying pressures without effecting the Priority flow rate.

**Flow Ranges:** 0 - 4 gpm, 0 - 8 gpm

**Maximum Pressure:** 3600 psi

**Ports:** 3/8" BSPP x 3 Ports, Manifold Mounted, 3/8" NPTF x 3 Ports

## VFD120 Series Variable Priority Flow Dividers (2FV2V replacement)

Aimed at mobile and industrial applications the VFD120 can be used for controlling hydraulic motor and cylinder speeds by manually adjusting the flow rate.

Variable priority flow dividers split a single input (P) flow into a priority (REG) flow and an excess or by-pass (BP) flow which can be returned directly to the oil reservoir or

used to power a second system. This is possible due to the valve's adaptive pressure compensation characteristics meaning both the priority and by-pass flows can be used to drive separate circuits, even under varying loads. In many instances this dispenses with the need for another pump to operate a second system.

### Features:

- Clearly marked single-turn hand dial permits fast visual adjustments to pre-determined 'Priority' flow.
- Pressure compensated permitting both 'Priority' and 'By-Pass' to be used simultaneously at varying pressures without affecting the 'Priority' flow rate.



- Anti-tamper locknut option available. Contact Sales Office for more information.
- Reverse flow capable (Depending upon control knob position) Contact Sales office for more information.

**Flow Ranges:** 0 - 3.0 gpm, 0 - 5.0 gpm, 0 - 8.0 gpm, 0 - 16.0 gpm, 0 - 20.0 gpm, 0 - 25.0 gpm

**Maximum Pressure:** 6000 psi

**Port Threads Inlet Regulated Flow and Excess Flow:**

1/2" BSPP, 3/4" BSPP, 1-1/16" -12UN #12 SAE ORB, 3/4" NPTF \*1, M22 x 1.5

Two bolt - M8 or 5/16"

## Other Variable Priority Flow Dividers available

- **RV2FV2V** Variable Priority Flow Divider with Relief Internally Drained. Specifications as above with relief from Priority to Bypass.
- **AC2FV2V** Variable Priority Flow Divider with Anti Cavitation Check from Priority to Bypass



- **CK2FV2V** Variable Priority Flow Divider with Reverse Flow Check from Priority to Inlet

## VFD120 Motor-Driven Series Variable Priority Flow Divider with Remote Proportional Control.

The VFD120MD remote control flow divider is ideally suited for the agricultural and industrial user seeking a cost-effective method of controlling hydraulic

motor speed. The priority flow port gives an output independent of load pressure while the By-Pass port can be used to power a secondary circuit.

### Features:

- Minimum to maximum priority flow in less than 10 seconds (at full pressure)
- 1 – 28 Vdc supply enables unit to be powered from a vehicle supply
- Remote control using:
  - Potentiometer
  - 0.5 - 5 Vdc
  - 4 - 20 mA loop
- Set and Forget
- No external control box needed. All electronics are self-contained inside the canister.



- Easy setup on-field. All connections made via M12 connector
- Pressure compensated permitting both 'priority' and 'By-Pass' flow to be used simultaneously at varying pressures without affecting the 'priority' flow rate.
- Automatic current limiting to prevent overheating and motor overload
- Valve settings immune to power failure
- Certified to IP66 (with cable connected)

**Flow Ranges:** 0\* - 3.0 gpm, 0\* - 5.0 gpm, 0\* - 8.0 gpm, 0\* - 12.0 gpm, 0.5\* - 16.0 gpm, 0.5\* - 20.0 gpm, 1\* - 25.0 gpm, 1.5\* - 30.0 gpm

**Maximum Pressure:** 6000 psi

### Port Threads Inlet Regulated Flow and Excess Flow:

1/2" BSPP, 3/4" BSPP, 1-1/16" -12UN #12 SAE ORB, 3/4" NPTF<sup>2</sup>, M22 x 1.5

## 2FV2V Series Manifold Mounted Variable Priority Flow Divider

Priority Type Flow Dividers split a single input flow into a 'Priority' (regulated) flow and a 'By-Pass' (excess) flow which can be returned directly to the oil reservoir or used to power

a second system. In many instances this dispenses with the need for another pump to operate a second system.

### Features:

- Pressure compensated permitting both 'Priority' and 'By-Pass' flows to be used simultaneously at varying pressures without affecting the 'Priority' flow rate.
- Can be used as uni-directional two port in line flow control by plugging the 'By-Pass' flow port. (**Note:** in this configuration a relief valve must be used on the inlet line).



- Manifold Mounted.
- Anti-tamper locknut option available for all models, Contact sales office for more information.
- For intermittent reverse flow, needle valve 'pull back' facility available on request.

**Flow Ranges:** 0 - 3 gpm, 0 - 5 gpm, 0 - 8 gpm, 0 -12.5 gpm

**Maximum Pressure:** 3600 psi

**Ports:** Manifold Mounted

## VFD190 Series Variable Priority Flow Dividers

Aimed at mobile and industrial applications the VFD190 can be used for controlling hydraulic motor and cylinder speeds by manually adjusting the flow rate.

Variable priority flow dividers split a single input (P) flow into a priority (REG) flow and an excess or by-pass (BP) flow which can be returned directly to the oil reservoir or used to power a second system. This is possible due to the valve's adaptive pressure compensation characteristics

### Features:

- Clearly marked single-turn hand dial permits fast visual adjustments to pre-determined 'Priority' flow and fast easy adjustments of 'Priority' circuit to meet varying requirements.
- Pressure compensated permitting both 'Priority' and 'By-Pass' to be used simultaneously at varying pressures without affecting the 'Priority' flow rate.



- Needle Valve can be pulled back to allow intermittent reverse flow
- Anti-tamper locknut option available for all models, Contact Sales Office for more information.

### Flow Ranges:

**Nominal Regulated Flow:** 20 gpm, 25 gpm, 30 gpm, 35 gpm, 40 gpm

**Nominal Input Flow:** 25 gpm, 32 gpm, 37 gpm, 44 gpm, 50 gpm

**Maximum Pressure:** 6000 psi

**Ports:** Contact sales for detailed Porting information

## FDC60 Fixed Flow Divider

A Flow Divider-Combiner will divide a single flow into two separate flows which will always be in the same ratio to each other regardless of any pressure differential between the two lines. If the flow is reversed (e.g. return stroke of

two cylinders) the return flows are held in the same ratio to each other and combined into a single flow, regardless of individual loads on the cylinders

### Features:

- Pressure compensated to keep the two divided flow rates at the same ratio regardless of pressure variations between them.
- Flow ratios are pre-set at factory from 50% - 50% up to 10% - 90%.



- Flow ranges are available from 1.3 - 18.5 gpm.
- Cast iron/hardened steel construction (no aluminium) makes it suitable for mining applications.

**Flow Ranges:** 0.5 - 1.3 gpm, 1.3 - 2.6 gpm, 2.1 - 5.3 gpm, 4.2 - 8 gpm, 6.6 - 10 gpm, 9 - 13 gpm, 12 - 16 gpm, 14.5 - 18.5 gpm

**Maximum Pressure:** 4500 psi

**Ports:** Contact sales for detailed Porting information

## SV80 Series Diverter Valve

A Diverter Valve provides an alternative to the standard directional control valve when a neutral position is not required. It allows flow to be directed into either of two lines

which enables fast changing from one system to another, or from one system to tank thus providing an idling circuit.

### Features:

- Flow may be directed by mechanically pushing the spool with spring offset or by a mechanical push pull operation in which case the valve stem is threaded or fitted with a moulded knob.



- Customer can select from one of two spool types allowing flow to be diverted from one line to another or from system to tank.
- A choice of port threads are available.
- Special versions also available.

**Maximum Flow:** 20 gpm, **Maximum Pressure:** 3000 psi

**Ports:** 1/2" BSPP, 7/8" -14UN #10 SAE ORB, M22 x 1.5, 1/2" NPTF

**Operation:** Spring Offset, Mechanical Push - Manual, Push - Pull - Threaded, Push - Pull

## DV80 Series Diverter Valve

A Diverter Valve provides an alternative to the standard directional control valve when a neutral position is not required. It allows flow to be directed into either of two lines

which enables fast changing from one system to another, or from one system to tank thus providing an idling circuit.

### Features:

- Flow may be directed by mechanically pushing the spool with spring offset.
- Customer can select from one of two spool types allowing flow to be diverted from one line to another or from system to tank.



- A choice of port threads and spool end types are available.
- Spring and spool end protected from environment in sealed housing.
- Special versions also available

**Maximum Flow:** 20 gpm, **Maximum Pressure:** 3000 psi

**Ports:** 1/2" BSPP, 7/8" -14UN #10 SAE ORB

**Operation:** Roller, Ball, Manual

## 180 Series Manual Directional Control Valve

The 180 series of high-pressure aluminium hydraulic rotary shear directional control valves are the ideal solution for control of hydraulic actuators on mobile and industrial applications where internal leakage must be minimised.

The valves utilise an optically flat rotary spool with pressure loaded seats, to ensure either zero or near zero leakage. They have excellent tolerance to contaminants.

### Features:

- 6 Center conditions
- 3 position / 2 position
- Flow throttling capability
- Zero leakage
- Spring to center or detent action



- Position lock version available (button or removable key type)
- Option of a pressurised tank port with additional drain
- Maximum Tank line pressure 17.2 bar, 250 psi

**Flow Ranges:** up to 10 gpm, three sizes available

**Maximum Pressure:** up to 10000 psi

**Ports:** SAE, NPTF, BSPP, Manifold Mount & D03 adapter available

## 280 Series Stainless Steel Rotary Control Valve

The 280 series of high-pressure 316 stainless steel hydraulic rotary control valves are the ideal solution for control of hydraulic actuators used in arduous environments where internal leakage must be minimised.

The valves utilise an optically flat rotary spool with pressure loaded seats, to ensure either zero or near zero leakage (depending on flow size). The Valve is compatible with water glycol hydraulic fluids.

### Features:

- Over 4000 possible configurations
- 3 position / 2 position
- 4 port / 3 port
- Zero leakage (15 lpm version)
- Maximum tank line pressure up to 1450 psi (100 bar)
- BS EN13463-1:2009 (ATEX) rating of 'II 3G TX'



- Standard documentation:-
  - Manual
  - Certificate of Conformity
  - Performance test Certificate
  - Declaration of Conformity to 'ATEX'
- Option of manufacture to EN10204-3.1
- Same day dispatch available

**Flow Ranges:** up to 10 gpm, three sizes available

**Maximum Pressure:** up to 10000 psi

**Ports:** SAE, NPTF, BSPP, Manifold Mount & D03 adapter available

## BG4D Lever Operated Directional Control Valve

Rugged directional control valve ideal for general mobile and industrial hydraulic applications. Features low spool leakage and 3625 psi tank port rating. Also available with

cam actuation and air or oil pilot operation. 5 spool types including a special hose rewind spool and 2 position option.

### Features:

- Nominal flow rate: 14.5 gpm
- Max. operating pressure: 3625 psi
- Max. pressure on 'T' port: 3625 psi
- Recommended operating viscosity range: min. 13 Cst - max 400 Cst
- Recommended operating temperature range: min. -22 °F - max 176 °F
- Available with relief valve from P-T, 3000 psi max.



**Ports:** Contact sales office for details

- Recommended filtration: 25 microns or better
- Seals medium nitrile (contact Technical Sales for alternatives)
- Leakage: typical max. allowable on works test 0.004 gpm at 2000 psi, oil 35 cSt at 104 °F
- Mounting unrestricted
- Lever, Cam, Air or Oil pilot actuation

## YB Series Pumps

Compact, light weight aluminium gear pumps available in six displacements from 0.15 to 0.73 in<sup>3</sup>/rev at pressures to 2000 psi continuous, 2500 psi intermittent duty.



## MYB Series Motors

Compact, light weight aluminium gear motors available in four displacements from 0.29 to 1.73 in<sup>3</sup>/rev. Efficient performance at speeds to 5000 rpm & supply pressure to 2000 psi.

## B Series Pumps

Basic - cast iron fixed clearance gear pumps available in nine displacements from 0.11 to 0.74 in<sup>3</sup>/rev at pressures to 3500 psi.



## MB Series Motors

Basic - cast iron fixed clearance gear motors available in seven displacements from 0.15 to 0.59 in<sup>3</sup>/rev at supply pressure to 2500 psi.

## YC Series Pumps

Compact, light weight aluminium gear pumps with pressure balanced design available in six displacements from 0.58 to 1.94 in<sup>3</sup>/rev at pressures to 2500 psi.



## MYC Series Motors

Compact, light weight aluminium gear motors with pressure balanced design available in six displacements from 0.58 to 1.94 in<sup>3</sup>/rev and speeds to 5000 rpm.

## K Series Pumps

Highly flexible multi-section, rugged, dependable gear pumps with pressure balanced wear plate available in nine displacements from 0.86 to 3.88 in<sup>3</sup>/rev.



## MK Series Motors

Highly flexible, rugged, dependable gear motors available in seven displacements from 1.29 to 3.88 in<sup>3</sup>/rev with 1300 lb-in torque at speeds to 2000 rpm with 2500 psi supply pressure.

### Imperial Hydraulic Motor or Engine Torque

$$T = \frac{5252 \times \text{HP}}{\text{rpm}}$$

Where: T = Torque in pounds feet  
 HP = Horsepower  
 rpm = Engine speed in revolutions per minute

**Example:** What is the torque of an engine that develops 40 HP at 2500 rpm?

$$T = \frac{5252 \times 40}{2500} = 84 \text{ lbs} \cdot \text{feet}$$

### Axle Torque

The torque available at the driving axle is the hydraulic motor torque multiplied by gear reduction through the transmission and axle.

Where Ta = T x Rta x Ra  
 Ta = Axle torque (lb in)  
 Ra = Axle gear reduction  
 Rta = Gear reduction through auxiliary transmission if used  
 T = Motor torque (lb in)

**Example:** What is the rear axle torque in high gear on a vehicle having 1000 lb in motor torque, an auxiliary ratio of 4:1, and an axle ratio of 20:1.

$$Ta = 1000 \times 4 \times 20 = 80,000 \text{ lb in.}$$

### Hydraulic Motor Torque Required

The torque required to slip the wheels is the vehicle weight over the driving tires times the coefficient of friction of the driving tires on rolling surface times the rolling radius of tires divided by the overall gear reduction.

$$ST = \frac{VW \times u \times r}{R}$$

Where VW: = Vehicle weight over driving tires VW (lbs)  
 u = Coefficient of friction of tires on average road surface, generally 0.6.  
 T = Rolling radius of loaded driving tire in inches.  
 R = Overall gear reduction in both axle and transmission.

### Hydraulic Motor Torque To Slip Wheels

**Example:** What is the motor torque required to slip wheels of a vehicle where the weight over the driving tire is 2000lb, the coefficient of friction of the tires is 0.6., the rolling radius is 15 inches. The total reduction of power train is 10.

$$ST = \frac{2000 \times .6 \times 15}{10} = 1800 \text{ lb in}$$

### Hydraulic Motor Speed From mph

The motor speed is obtained by multiplying 168 by the ratio of the power train by the miles per hour and dividing this sum by the rolling radius of the tire.

$$\text{rpm} = \frac{168 \times R \times \text{mph}}{r}$$

### Metric Hydraulic Motor or Engine Torque

$$T = \frac{9.545 \times P}{\text{rpm}}$$

Where: T = Torque in newton metre (N m)  
 P = Power in watts (W)  
 rpm = Engine speed in revolutions per minute

**Example:** What is the torque of an engine that develops 30,000w at 2500 rpm?

$$T = \frac{9.545 \times 30,000}{2500} = 114.54 \text{ N} \cdot \text{m}$$

### Axle Torque

The torque available at the driving axle is the hydraulic motor torque multiplied by gear reduction through the transmission and axle.

Where Ta = T x Rta x Ra  
 Ta = Axle torque (N m)  
 Ra = Axle gear reduction  
 Rta = Gear reduction through auxiliary transmission if used  
 T = Motor torque (N m)

**Example:** What is the rear axle torque in high gear on a vehicle having 100 Nm in motor torque, an auxiliary ratio of 5:1, and an axle ratio of 20:1.

$$Ta = 100 \times 5 \times 20 = 10,000 \text{ N m.}$$

### Hydraulic Motor Torque Required

The torque required to slip the wheels is the vehicle weight over the driving tires times the coefficient of friction of the driving tires on rolling surface times the rolling radius of tires divided by the overall gear reduction.

$$ST = \frac{VW \times u \times r}{R \times 101.97}$$

Where VW: = Vehicle weight over driving tires VW (kg)  
 u = Coefficient of friction of tires on average road surface, generally 0.6.  
 r = Rolling radius of loaded driving tire in millimetres.  
 R = Overall gear reduction in both axle and transmission.

### Hydraulic Motor Torque To Slip Wheels

**Example:** What is the motor torque required to slip wheels of a vehicle where the weight over the driving tire is 1000 kg, the coefficient of friction of the tires is 0.6., the rolling radius is 400 mm. The total reduction of power train is 10.

$$ST = \frac{1000 \times 0.6 \times 400}{10 \times 101.97} = 235.36 \text{ Nm}$$

### Hydraulic Motor Speed From kph

The motor speed is obtained by multiplying 2651.51 by the ratio of the power train by the kilometres per hour and dividing this sum by the rolling radius of the tire.

$$\text{rpm} = \frac{2651.51 \times R \times \text{kph}}{r}$$

## Imperial

168	=	Factor
rpm	=	Revolutions per minute of engine
r	=	Rolling radius of loaded drive tire in inches
R	=	Overall gear reduction including both axle and transmission
mph	=	Vehicle speed in miles per hour

**Example:** Find the motor speed where the overall gear reduction is 10, vehicle speed is 15 mph and rolling radius of driving tire is 15 inches. 1680 rpm

$$\text{rpm} = \frac{168 \times 10 \times 15}{15} = 1680 \text{ rpm}$$

### Miles Per Hour From Motor Speed

Vehicles speed in miles per hour is the rolling radius of loaded driving tire multiplied by the motor rpm and divided by 168 times the overall gear reduction of the power train.

$$\text{mph} = \frac{\text{rpm} \times r}{168 \times R}$$

168	=	Factor
rpm	=	Revolutions per minute of the motor
r	=	Rolling radius of loaded driving tire in inches
R	=	Overall gear reduction including both axle and transmission
mph	=	Vehicle speed in miles per hour

**Example:** Find the mph of a vehicle where the motor speed is 1680 rpm, the rolling radius of loaded driving tire is 15 inches and the overall gear reduction is 10.

$$\text{mph} = \frac{1680 \times 15}{168 \times 10} = 15 \text{ mph}$$

### Tractive Effort

The tractive effort is obtained by multiplying the torque by the total ratio of power train and dividing this sum by the rolling radius of the driving tires.

$$\text{TE} = \frac{T \times R}{r}$$

Where: T	=	Motor torque in lb. in.
R	=	Overall gear reduction including both axle and transmission.
r	=	Rolling radius of loaded driving tire in inches.

**Example:** Find the tractive effort where the rolling radius of driving tires is 15 inches, the total ratio of power train is 10, the motor torque is 1000 lb in.

$$\text{TE} = \frac{1000 \times 10}{15} = 667$$

### Overall Gear Reduction

The overall gear reduction is the rpm times the rolling radius of the loaded driving tire divided by 168 times the vehicle speed in miles per hour.

$$R = \frac{\text{rpm} \times r}{168 \times \text{mph}}$$

## Metric

2651.51	=	Factor
rpm	=	Revolutions per minute of engine
r	=	Rolling radius of loaded drive tire in millimetres
R	=	Overall gear reduction including both axle and transmission
mph	=	Vehicle speed in kilometres per hour

**Example:** Find the motor speed where the overall gear reduction is 10, vehicle speed is 20 kph and rolling radius of driving tire is 400 millimetres.

$$\text{rpm} = \frac{2651.51 \times 10 \times 20}{400} = 1325.75 \text{ rpm}$$

### Kilometres Per Hour From Motor Speed

Vehicles speed in kilometres per hour is the rolling radius of loaded driving tire multiplied by the motor rpm and divided by 2651.51 times the overall gear reduction of the power train.

$$\text{kph} = \frac{\text{rpm} \times r}{2651.51 \times R}$$

2651.51	=	Factor
rpm	=	Revolutions per minute of the motor
r	=	Rolling radius of loaded driving tire in millimetres
R	=	Overall gear reduction including both axle and transmission
kph	=	Vehicle speed in kilometres per hour

**Example:** Find the kph of a vehicle where the motor speed is 1326 rpm, the rolling radius of loaded driving tire is 400 millimetres and the overall gear reduction is 10.

$$\text{kph} = \frac{1326 \times 400}{2651.51 \times 10} = 20 \text{ kph}$$

### Tractive Effort

The tractive effort is obtained by multiplying the torque by the total ratio of power train and dividing this sum by the rolling radius of the driving tires.

$$\text{TE} = \frac{T \times R \times 1000}{r}$$

Where: T	=	Motor torque in lb in.
R	=	Overall gear reduction including both axle and transmission.
r	=	Rolling radius of loaded driving tire in millimeters.

**Example:** Find the tractive effort where the rolling radius of driving tires is 400 millimetres, the total ratio of power train is 10, the motor torque is 115 Nm.

$$\text{TE} = \frac{115 \times 10 \times 1000}{400} = 2875 \text{ N}$$

### Overall Gear Reduction

The overall gear reduction is the rpm times the rolling radius of the loaded driving tire divided by 2651.51 times the vehicle speed in kilometres per hour.

$$R = \frac{\text{rpm} \times r}{2651.51 \times \text{kph}}$$



## Imperial

168	=	Factor
rpm	=	Revolutions per minute of engine
r	=	Rolling radius of loaded driving tire in inches
R	=	Overall gear reduction including both axle and transmission
mph	=	Vehicle speed in miles per hour

**Example:** Find out overall gear reduction of a vehicle where the motor speed is 1680 rpm, the rolling radius of loaded driving tire is 15 inches and the mph is 15.

$$R = \frac{1680 \times 15}{168 \times 15} = 10 \text{ to } 1$$

### Rolling Radius Of Loaded Driving Tire

The rolling radius of loaded driving tire is 168 times the overall gear reduction times the miles per hour divided by the engine speed.

$$r = \frac{168 \times R \text{ mph}}{\text{rpm}}$$

168	=	Factor
rpm	=	Revolutions per minute of the motor
r	=	Rolling radius of loaded driving tires in inches
R	=	Overall gear reduction including both axle and transmission
mph	=	Vehicle speed in miles per hour

**Example:** Find the rolling radius of loaded driving tire of a vehicle where the overall gear reduction is 10, the miles per hour 15 and the engine speed 1680 rpm.

$$r = \frac{168 \times 10 \times 15}{1680} = 15 \text{ inches}$$

### Road Rolling Resistance

The road rolling resistance is the force required to push a vehicle over the surface it is rolling over and maybe expressed in several ways. One, in terms of pounds resistance per thousand pounds of gross weight. Other methods are derived from this basic expression. Following is a table of rolling resistance in pounds per thousand pounds of gross weight for various road surfaces.

Rolling resistance is the gross vehicle weight in lbs, times the rolling resistance of the surface divided by 1000.

$$RR = \frac{GVW \times R}{1000}$$

Where: RR	=	Road rolling resistance in pounds
GVW	=	Gross vehicle weight in pounds
R	=	Rolling resistance in pounds per thousand pounds vehicle weight
1000	=	A constant to determine number of thousand pounds in vehicle

**Example:** What is the rolling resistance of a vehicle with a gross weight of 10,000 pounds on poor asphalt

$$RR = \frac{10,000 \times 22}{1000} = 220 \text{ lbs}$$

## Metric

2651.51	=	Factor
rpm	=	Revolutions per minute of engine
r	=	Rolling radius of loaded driving tire in millimetres
R	=	Overall gear reduction including both axle and transmission
kph	=	Vehicle speed in kilometres per hour

**Example:** Find out overall gear reduction of a vehicle where the motor speed is 1680 rpm, the rolling radius of loaded driving tire is 381mm and the kph is 24.

$$R = \frac{1680 \times 381}{2651.51 \times 24} = 10 \text{ to } 1$$

### Rolling Radius Of Loaded Driving Tire

The rolling radius of loaded driving tire is 2651.51 times the overall gear reduction times the kilometres per hour divided by the engine speed.

$$r = \frac{2651.51 \times R \times \text{kph}}{\text{rpm}}$$

2651.51	=	Factor
rpm	=	Revolutions per minute of the motor
r	=	Rolling radius of loaded driving tires in millimetres
R	=	Overall gear reduction including both axle and transmission
kph	=	Vehicle speed in kilometers per hour

**Example:** Find the rolling radius of loaded driving tire of a vehicle where the overall gear reduction is 10, the kilometres per hour 20 and the engine speed 1500 rpm.

$$r = \frac{2651.51 \times 10 \times 20}{1500} = 353.5 \text{ mm}$$

### Road Rolling Resistance

The road rolling resistance is the force required to push a vehicle over the surface it is rolling over a maybe expressed in several ways. One, in terms of newtons resistance per hundred kilograms of gross weight. Other methods are derived from this basic expression. Following is a table of rolling resistance in pounds per thousand pounds of gross weight for various road surfaces.

Rolling resistance in Newton per hundred kilograms is the gross vehicle weight in kg, times the rolling resistance of the surface divided by 100.

$$RR = \frac{GVW \times R}{100}$$

Where: RR	=	Road rolling resistance in newtons
GVW	=	Gross vehicle weight in kilograms
R	=	Rolling resistance in newtons per hundred kilograms vehicle weight
100	=	A constant to determine number of 100 kg in vehicle

**Example:** What is the rolling resistance of a vehicle with a gross weight of 4,500 kg on poor asphalt

$$RR = \frac{4,500 \times 22}{100} = 990 \text{ lbs}$$

## Imperial

Many formula are arranged to use the rolling resistance in the table below as a factor. To set the table data up in factor form divide the resistance in lbs by 1000.

$$Q = \frac{R}{1000}$$

- Where: Q = Rolling resistance factor per pound of gross vehicle weight.  
 R = Rolling resistance in pounds per thousand pounds vehicle weight.

**Example:** What is the rolling resistance factor per pound of gross vehicle weight on poor concrete?

$$Q = \frac{20}{1000} = .02$$

Another method of expressing road rolling resistance is percent of grade. To express rolling resistance in percent of grade multiply rolling resistance per thousand pounds vehicle by 100 and divide by 1000.

$$RR\% = \frac{R \times 100}{1000}$$

- Where: RR% = Road rolling resistance in percent Grade of grade  
 R = Rolling resistance pounds per thousand pounds vehicle weight  
 100 = A constant to express percent.

**Example:** What is the road rolling resistance expressed in percent of grade of a vehicle on poor concrete?

$$RR\% = \frac{20 \times 100}{1000} = 2\%$$

**Table Of Rolling Resistance In Pounds Per 1000 Pounds Of Gross Weight**

Concrete, excellent	10 lbs
Concrete, good	15 lbs
Concrete, poor	20 lbs
Asphalt, good	12 lbs
Asphalt, fair	17 lbs
Asphalt, poor	22 lbs
Macadam, good	15 lbs
Macadam, fair	22 lbs
Macadam, poor	37 lbs
Cobbles, ordinary	55 lbs
Cobbles, poor	85 lbs
Snow, 2 inch	25 lbs
Snow, 4 inch	37 lbs
Dirt, smooth	25 lbs
Dirt, sandy	37 lbs
Mud	37 lbs to 150 lbs
Sand, level soft sand	60 lbs to 150 lbs
Sand, dune	160 lbs to 300 lbs

## Metric

Many formula are arranged to use the rolling resistance in the table below as a factor. To set the table data up in factor form divide the resistance in N by 100

$$Q = \frac{R}{100}$$

- Where: Q = Rolling resistance factor per kilogram of gross vehicle weight.  
 R R = Rolling resistance in newtons per hundred kilograms vehicle weight.

**Example:** What is the rolling resistance factor per kilogram of gross vehicle weight on poor concrete?

$$Q = \frac{20}{100} = .2$$

Another method of expressing road rolling resistance is percent of grade. To express rolling resistance in percent of grade multiply rolling resistance per hundred kilograms vehicle by 100 and divide by 1000.

$$RR\% = \frac{R \times 100}{1000}$$

- Where: = Road rolling resistance in percent of RR% grade  
 R = Rolling resistance newtons per hundred kilograms vehicle weight  
 100 = A constant to express percent.  
 1000 = 100 x 10 (factor to account for discrepancy between newtons and kilograms).

**Example:** What is the road rolling resistance expressed in percent of grade of a vehicle on poor concrete?

$$RR\% = \frac{20 \times 100}{1000} = 2\%$$

**Table Of Rolling Resistance In Newtons Per 100 Kilogram Of Gross Weight**

Concrete, excellent	10 N
Concrete, good	15 N
Concrete, poor	20 N
Asphalt, good	12 N
Asphalt, fair	17 N
Asphalt, poor	22 N
Macadam, good	15 N
Macadam, fair	22 N
Macadam, poor	37 N
Cobbles, ordinary	55 N
Cobbles, poor	85 N
Snow, 2 inch	25 N
Snow, 4 inch	37 N
Dirt, smooth	25 N
Dirt, sandy	37 N
Mud	37 N to 150 N
Sand, level soft sand	60 N to 150 N
Sand, dune	160 N to 300 N

## Imperial Draw Bar Pull

The torque on the driving axle creates a force between the tires and the road which is used to propel the vehicle. This gross force is termed the tractive effort and the net force, that is, gross force minus rolling resistance is the draw bar pull.

$$DP = \frac{T \times R}{r} - \frac{RR}{1000} \times GVW$$

Where: DP = Draw bar pull in lbs  
 T = Motor torque in lb-in  
 R = Overall gear reduction including both axle and transmission  
 r = Rolling radius of loaded driving tire in inches  
 RR = Road rolling resistance in pounds  
 GVW = Gross vehicle weight of motive vehicle in pounds

**Example:** What is the draw bar pull of a vehicle with a motor torque of 1000 lb-in, an overall gear reduction of 10:1 and rolling radius of the driving tire is 15 inches and a GVW of 10,000 lbs over good concrete?

$$DP = \frac{1000 \times 10}{15} - \frac{15}{1000} \times 10000 = 516 \text{ lbs}$$

### Gradeability

Obviously, the tractive effort available at the wheels must be greater than the sum of the rolling resistance encountered. If this is not so, the transmission must be shifted to a lower gear in order to increase the tractive effort. The percentage of grade which can be negotiated is given by the formula.

$$G = \frac{100 \times T \times R}{r \times GVW} - RR$$

Where: 100 = A constant expressing percentage grade and inches.  
 T = Motor torque in lb inches  
 R = Overall gear reduction including both axle and transmission  
 r = Rolling radius of loaded driving tire in inches  
 GVW = Gross vehicle weight in pounds  
 RR = Rolling resistance expressed in percentage grade.

**Example:** What percentage grade can be negotiated by a vehicle having a hydraulic motor torque of 1000 lb inches, an overall gear reduction in high of 12 to 1, a tire rolling radius of 15 inches and a gross vehicle weight of 10,000 lbs over good concrete.

$$G = \frac{100 \times 1000 \times 12}{15 \times 10,000} - 1.5\%$$

$$G = 8 - 1.5 = 6.5\%$$

### Grade Resistance

The grade resistance of a vehicle is .01 times the gross weight times the percentage grade.

GR = .01 x GVW x % grade  
 Where: GR = Grade resistance  
 GVW = Gross vehicle weight

**Example:** What is the grade resistance of a vehicle having a gross weight of 10,000 lbs. on a 5% grade?

$$GR = .01 \times 10,000 \times 5 = 500 \text{ lbs}$$

## Metric Draw Bar Pull

The torque on the driving axle creates a force between the tires and the road which is used to propel the vehicle. This gross force is termed the tractive effort and the net force, that is, gross force minus rolling resistance is the draw bar pull.

$$DP = \frac{T \times R}{r} - \frac{RR}{100} \times GVW$$

Where: DP = Draw bar pull in newtons  
 T = Motor torque in newton metre's  
 R = Overall gear reduction including both axle and transmission  
 r = Rolling radius of loaded driving tire in millimetres  
 RR = Road rolling resistance in newtons  
 GVW = Gross vehicle weight of motive vehicle in kilograms

**Example:** What is the draw bar pull of a vehicle with a motor torque of 115 N m, an overall gear reduction of 10:1 and rolling radius of the driving tire is 400 millimetres and a GVW of 4,500 kilograms

$$DP = \frac{115 \times 10 \times 1000}{15} - \frac{15}{100} \times 4500 = 2200 \text{ N}$$

### Gradeability

Obviously, the tractive effort available at the wheels must be greater than the sum of the rolling resistances encountered. If this is not so, the transmission must be shifted to a lower gear in order to increase the tractive effort. The percentage of grade which can be negotiated is given by the formula.

$$G = \frac{T \times R \times 10200}{r \times GVW} - RR$$

Where: 1000 = Factor  
 T = Motor torque in newton metre's  
 R = Overall gear reduction including both axle and transmission  
 r = Rolling radius of loaded driving type in millimetres  
 GVW = Gross vehicle weight in kilograms  
 RR = Rolling resistance expressed percentage grade.

**Example:** What percentage grade can be negotiated by a vehicle having a hydraulic motor torque of 117 newton metre's, an overall gear reduction in high of 12 to 1, a tire rolling radius of 400 mm and a gross vehicle weight of 4,500 kg over good concrete.

$$G = \frac{117 \times 121 \times 200}{400 \times 4500} - 1.5\%$$

$$G = 8 - 1.5 = 6.5\%$$

### Grade Resistance

The grade resistance of a vehicle is 0.0981 times the gross weight times the percentage grade.

GR = 0.0981 x GVW x % grade  
 Where: GR = Grade resistance in newtons  
 GVW = Gross vehicle weight in kilograms

**Example:** What is the grade resistance of a vehicle having a gross weight of 4,500 kg. on a 5% grade?

$$GR = 0.0981 \times 4,500 \times 5 = 2207.25 \text{ N}$$

## Imperial Air Resistance

The air resistance against a vehicle is a force in lbs equal to .0025 times the miles per hour squared times the frontal area.

Where: AR = .0025 mph<sup>2</sup> x FA  
 AR = Air resistance in lbs  
 mph = Speed in miles per hour  
 FA = Frontal area of vehicle in sq. ft

**Example:** What is the air resistance of a vehicle travelling 40 miles per hour and having a frontal area of 80 square feet?

$$AR = .0025 \times (40)^2 \times 80 = 320 \text{ lbs}$$

## Horsepower Required To Overcome Air Resistance

The horsepower required to overcome air resistance is the speed in miles per hour, cubed, times the frontal area in square feet divided by 150,000

$$HP = \frac{\text{mph}^3 \times FA}{150,000}$$

mph = Speed in miles per hour  
 FA = Frontal area in square feet  
 HP = Horsepower  
 150,000 = A conversion constant

**Example:** What is the horsepower required to overcome air resistance of a vehicle travelling 40 miles per hour and having a frontal area of 80 square feet?

$$HP = \frac{40^3 \times 80}{150,000} = 34.13$$

## Ground Speed Of Track Laying Vehicle

The ground speed of a track laying vehicle is the hydraulic motor rpm times the circumference of the driving sprocket divided by 168 times 2 times 3.1416 times the overall gear reduction of the power train.

$$V = \frac{\text{rpm} \times C}{168 \times 2 \times 3.1416 \times R}$$

Where: V = Ground speed in mph  
 rpm = Rev. per min. of engine  
 C = Circumference  
 C = N x L  
 N = No. of teeth in sprocket  
 L = Length of links in inches  
 R = Overall gear reduction

**Example:** Find the ground speed in miles per hour where the motor speed is 1800 rpm, the number of teeth in the sprocket is 41, the length of link 8", and the total reduction of power train is 61 to 1.

$$C = 41 \times 8 = 328$$

$$V = \frac{1800 \times 328}{168 \times 2 \times 3.1416} \times 61 = 9.169 \text{ mph}$$

## Metric Air Resistance

The air resistance against a vehicle is a force in newtons equal to 0.0462 times the kilometres per hour squared times the frontal area.

Where: AR = 0.0462 x kph<sup>2</sup> x FA  
 AR = Air resistance in newtons  
 kph = Speed in kilometres per hour  
 FA = Frontal area of vehicle in sq. metre's

What is the air resistance of a vehicle travelling 65 kilometres per hour and having a frontal area of 7.5 m<sup>2</sup>?

$$AR = 0.0462 \times (65)^2 \times 7.5 = 1464 \text{ N}$$

## Horsepower Required To Overcome Air Resistance

The power required to overcome air resistance is the speed in kilometres per hour, cubed, times the frontal area in divided by 77.86

$$P = \frac{\text{kph}^3 \times FA}{77.86}$$

kph = Speed in kilometres per hour  
 FA = Frontal area in square meters  
 P = Power in watt  
 77.86 = A conversion factor

What power is required to overcome air resistance of a vehicle travelling 65 kilometres per hour and having a frontal area of 7.5 m<sup>2</sup>?

$$P = \frac{(65^3) \times 7.5}{77.86} = 26453.73 \text{ Watts}$$

## Ground Speed Of Track Laying Vehicle

The ground speed of a track laying vehicle is the hydraulic motor rpm times the circumference of the driving sprocket divided by 16660 times the overall gear reduction of the power train.

$$V = \frac{\text{rpm} \times C}{16660 \times R}$$

Where: V = Ground speed in kph  
 rpm = Rev. per min. of engine  
 C = Circumference  
 C = N x L  
 N = No. of teeth in sprocket  
 L = Length of links in millimetres  
 R = Overall gear reduction

Find the ground speed in kilometres per hour where the motor speed is 1800 rpm, the number of teeth in the sprocket is 41, the length of link 200 mm, and the total reduction of power train is 61 to 1.

$$C = 41 \times 200 = 8200$$

$$V = \frac{1800 \times 8200}{16660 \times 61} = 14.524 \text{ kph}$$

## Viscosity of Hydraulic Oil

The internal resistance to flow of a liquid is measured as viscosity. More precisely absolute viscosity ( $\mu$ ) which is defined in terms of the shear force between two parallel layers of fluid for a certain slip velocity between them.

This is represented by Newton's equation ( $\tau = \mu \frac{\partial u}{\partial y}$ ).

Very often a hydraulic fluid will be selected on the basis of its viscosity and the operating temperature of the system. A fluid will flow more easily the less viscous it is, since less energy is required to overcome the internal frictional forces. Any saving in energy must be balanced against an increase in leakage due to the lower fluid viscosity.

There are two measures of viscosity: absolute (also known as dynamic) and kinematic. The S.I. unit for absolute viscosity is  $\text{N s m}^{-2}$  or Pa.s. The non-S.I. unit is the poise (P) equivalent to  $0.1 \text{ N s m}^{-2}$  (not to be confused with the poiseuille (Pl), used in France, and equal to 10 poise) though the centipoise (cP) is more commonly used. In the hydraulics industry kinematic viscosity is more frequently used, where:

$$\text{kinematic viscosity} = \frac{\text{dynamic viscosity}}{\text{density}}$$

The S.I. unit for kinematic viscosity ( $\nu$ ) is  $\text{mm}^2 \text{ s}^{-1}$  which corresponds to the older but still commonly used unit the centistoke (cSt).

Past measures of viscosity using arbitrary scales like Redwood No 1 seconds, Saybolt Universal Seconds (SUS), or degrees Engler should no longer be used. These units have been superseded by the empirical measures previously mentioned; conversion tables do exist but are only true at a fixed temperature.

## Effect of temperature on viscosity

The temperature and viscosity of hydraulic oil are inversely related; as temperature increases, viscosity decreases. In order to define the kinematic viscosity of oil, its viscosity is quoted at a set temperature ( $40^\circ\text{C}$  for the ISO standard) and the oil is given a value according to the viscosity index (V.I.). For example an oil quoted as conforming to ISO 22 will have a viscosity of  $22 \text{ mm}^2\text{s}^{-1}/\text{cSt}$  at  $40^\circ\text{C}$ .

## Viscosity Index

The viscosity index is a single number representation of the viscosity temperature characteristics of a fluid. The greater the value of the V.I. the smaller the change in viscosity for a given change in temperature, and vice-versa. Oils with a V.I. of 80 or more are said to have a high V.I. value. Oils with a V.I. between 80 and 40 are said to have a medium value and those below 40 a low value. Typically mineral oils used by the fluid power industry have a high V.I. of about 100. If temperature and kinematic viscosity are plotted to give a linear relationship (using logarithmic scales) then the V.I. is a measure of the gradient of the line. As the V.I. is increased the gradient is reduced. A typical temperature-viscosity curve for ISO oils can be seen opposite.

## Effect of pressure on viscosity

Contrary to popular belief, varying pressure can lead to significant variations in viscosity. In a closed flow circuit at a fixed temperature, a change in pressure of 6000 psi (400 bar) can lead to a change of up to 8% in viscosity. However there are problems in calculating this variation.

## Density and specific volume

The density of mineral oils is typically around  $870\text{kg m}^{-3}$  (In comparison synthetic oils usually have a density of around  $1200\text{kg m}^{-3}$ ). The specific gravity, the ratio of the density of the fluid to the density of water, is a dimensionless quantity typically 0.87 for mineral oils.

## Graph of Temperature versus Kinematic Viscosity

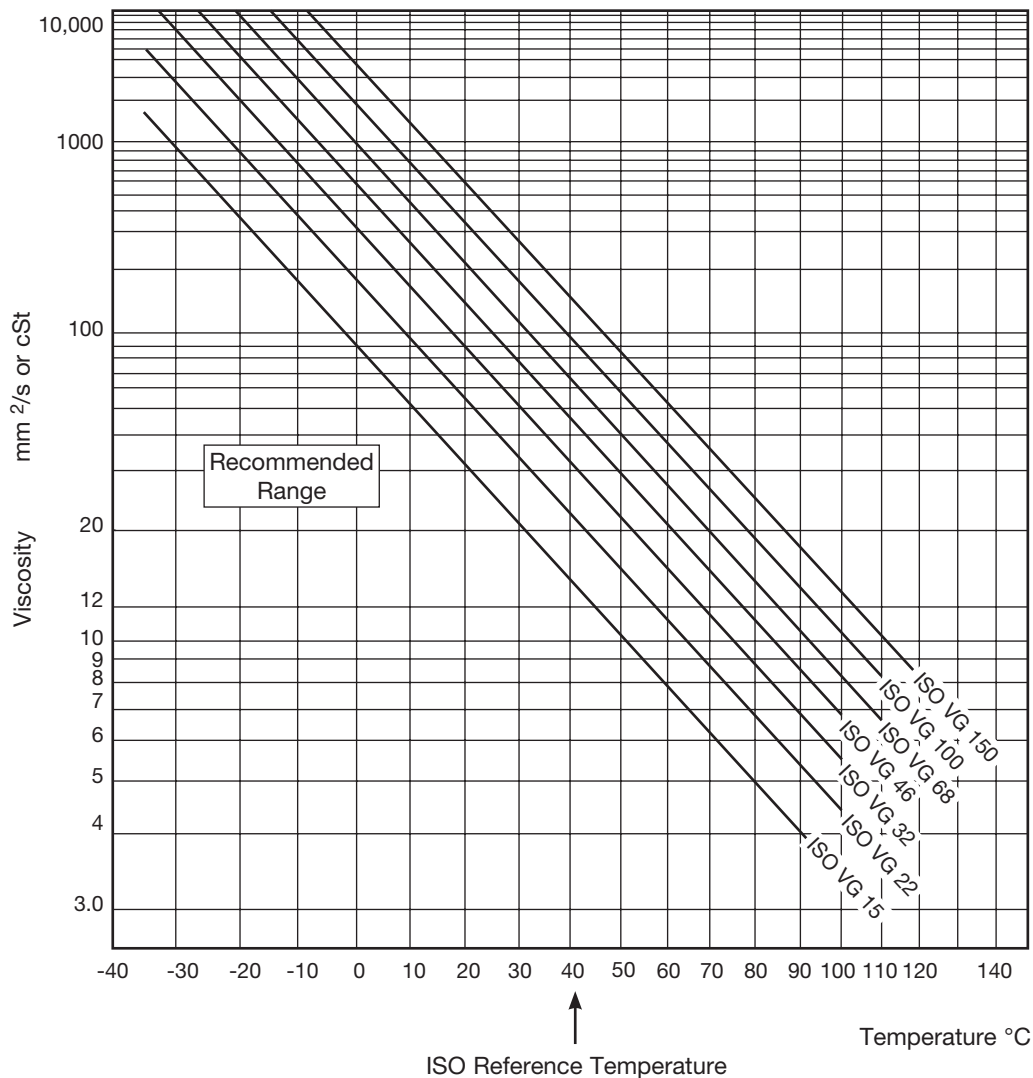

## Metric Conversion Factors

Symbols of SI units, multiples and submultiples are given in parentheses in the right hand column

Multiply	By	To Obtain
<b>Length</b>		
centimetre	0.03280840	foot
centimetre	0.3937008	inch
fathom	1.8288*	metre (m)
foot	0.3048*	metre (m)
foot	30.48*	centimetre (cm)
foot	304.8*	millimetres (mm)
inch	0.0254*	metre (m)
inch	2.54*	centimetre (cm)
inch	25.4*	millimetre (mm)
kilometre	0.6213712	mile (US statute)
metre	39.37008	inch
metre	0.5468066	fathom
metre	3.280840	foot
metre	0.1988388	rod
metre	1.093613	yard
metre	0.0006213712	mile (US statute)
microinch	0.0254*	micrometre (micron)(um)
Micrometre (Micron)	39.37008	microinch
mile (US statute)	1,609.344*	metre (m)
mile (US statute)	1.609.344*	kilometre (km)
millimetre	0.003280840	foot
millimetre	0.03937008	inch
rod	5.0292*	metre (m)
yard	0.9144*	metre (m)
<b>Area</b>		
acre	4046.856	metre <sup>2</sup> (m <sup>2</sup> )
acre	0.4046856	hectare
centimetre <sup>2</sup>	0.1550003	inch <sup>2</sup>
centimetre <sup>2</sup>	0.001076391	foot <sup>2</sup>
foot <sup>2</sup>	0.09290304*	metre <sup>2</sup> (m <sup>2</sup> )
foot <sup>2</sup>	929.0304*	centimetre <sup>2</sup> (cm <sup>2</sup> )
foot <sup>2</sup>	92,903.04*	millimetre <sup>2</sup> (mm <sup>2</sup> )
hectare	2.471054	acre
inch <sup>2</sup>	645.16*	millimetre <sup>2</sup> (mm <sup>2</sup> )
inch <sup>2</sup>	6.4516*	centimetre <sup>2</sup> (cm <sup>2</sup> )
inch <sup>2</sup>	0.00064516*	metre <sup>2</sup> (m <sup>2</sup> )
metre <sup>2</sup>	1,550.003	inch <sup>2</sup>
metre <sup>2</sup>	10.763910	foot <sup>2</sup>
metre <sup>2</sup>	1.195990	yard <sup>2</sup>
metre <sup>2</sup>	0.0002471054	acre
millimetre <sup>2</sup>	0.00001076391	foot <sup>2</sup>
millimetre <sup>2</sup>	0.001550003	inch <sup>2</sup>
yard <sup>2</sup>	0.8361274	metre <sup>2</sup> (m <sup>2</sup> )

\* Where an Asterisk is shown, the figure is exact.

Multiply	By	To Obtain
<b>Volume (including Capacity)</b>		
centimetre <sup>3</sup>	0.06102376	inch <sup>3</sup>
foot <sup>3</sup>	0.02831685	metre <sup>3</sup> (m <sup>3</sup> )
foot <sup>3</sup>	28.31685	litre
gallon (UK liquid)	0.004546092	metre <sup>3</sup> (m <sup>3</sup> )
gallon (UK liquid)	4.546092	litre
gallon (US liquid)	0.003785412	metre <sup>3</sup> (m <sup>3</sup> )
gallon (US liquid)	3.785412	litre
inch <sup>3</sup>	16.38706	milliliter <sup>3</sup> (ml <sup>3</sup> )
inch <sup>3</sup>	16.38706	centimetre <sup>3</sup> (cm <sup>3</sup> )
inch <sup>3</sup>	0.0000168706	metre <sup>3</sup> (m <sup>3</sup> )
litre	0.001*	metre <sup>3</sup> (m <sup>3</sup> )
litre	0.2199692	gallon (UK liquid)
litre	0.2641720	gallon (US liquid)
litre	0.03531466	foot <sup>3</sup>
metre <sup>3</sup>	219.9692	gallon (UK liquid)
metre <sup>3</sup>	264.1720	gallon (US liquid)
metre <sup>3</sup>	35.31466	foot <sup>3</sup>
metre <sup>3</sup>	1.307951	yard <sup>3</sup>
metre <sup>3</sup>	1000.	litre
metre <sup>3</sup>	61.023.76	inch <sup>3</sup>
millimetre <sup>3</sup>	0.00006102376	inch <sup>3</sup>
yard <sup>3</sup>	0.7645549	metre <sup>3</sup> (m <sup>3</sup> )
<b>Velocity, Acceleration, and Flow</b>		
centimetre/second	1.968504	foot/minute
centimetre/second	0.03280840	foot/second
centimetre/minute	0.3937008	inch/minute
foot/hour	0.00008466667	metre/second (m/s)
foot/hour	0.00508*	metre/minute
foot/hour	0.3048*	metre/hour
foot/minute	0.508*	centimetre/second
foot/minute	18.288*	metre/hour
foot/minute	0.3048*	metre/minute
foot/minute	0.00508*	metre/second (m/s)
foot/second	30.48*	centimetre/second
foot/second	18.288*	metre/minute
foot/second	0.3048	metre/second (m/s)
foot/second <sup>2</sup>	0.3048*	metre/second <sup>2</sup> (m/s <sup>2</sup> )
foot <sup>3</sup> /minute	28.31685	litre/minute
foot <sup>3</sup> /minute	0.0004719474	metre <sup>3</sup> /second (m <sup>3</sup> /s)
gallons/min (US liquid)	0.003785412	metre <sup>3</sup> /minute
gallons/min (US liquid)	0.00006309020	metre <sup>3</sup> /second (m <sup>3</sup> /s)
gallons/min (US liquid)	0.06309020	litre/second
gallons/min (US liquid)	3.785412	litre/minute
gallons/min (US liquid)	0.004546092	metre <sup>3</sup> /minute
gallons/min (US liquid)	0.00007576820	metre <sup>3</sup> /second (m <sup>3</sup> /s)
inch/minute	25.4*	millimetre/minute
inch/minute	2.54*	centimetre/minute
inch/minute	0.0254*	metre/minute
inch/second <sup>3</sup>	0.0254*	metre/second <sup>3</sup> (m/s <sup>3</sup> )



Multiply	By	To Obtain
<b>Velocity, Acceleration and Flow (Continued)</b>		
kilometre/hour	0.6213712	mile/hour (US statute)
litre/minute	0.03531466	foot <sup>3</sup> /minute
litre/minute	0.2641720	gallons/min (US liquid)
litre/second	15.85032	gallons/min (US liquid)
mile/hour	1.609344*	kilometre/hour
millimetre/minute	0.03937008	inch/minute
metre/second	11,811.02	foot/hour
metre/second	196.8504	foot/minute
metre/second	3.280840	foot/second
metre/second <sup>2</sup>	3.280840	foot/second <sup>2</sup>
metre/second <sup>2</sup>	39.37008	inch/second <sup>2</sup>
metre/minute	3.280840	foot/minute
metre/minute	0.05468067	foot/second
metre/minute	39.37008	inch/minute
metre/hour	3.280840	foot/hour
metre/hour	0.05468067	foot/minute
metre <sup>3</sup> /second	2118.880	foot <sup>3</sup> /minute
metre <sup>3</sup> /second	13,198.15	gallon/minute (UK liquid)
metre <sup>3</sup> /second	15,850.32	gallon/minute (US liquid)
metre <sup>3</sup> /minute	219.9692	gallon/minute (UK liquid)
metre <sup>3</sup> /minute	264.1720	gallon/minute (US liquid)
<b>Mass and Density</b>		
grain(1/7000 lb avoirdupois)	0.06479891	gram (g)
gram	15.43236	grain
gram	0.001*	kilogram (kg)
gram	0.03527397	ounce (avoirdupois)
gram	0.03215074	ounce (troy)
gram/centimetre <sup>3</sup>	0.03612730	pound/inch <sup>3</sup>
hundredweight (long)	50.80235	kilogram (kg)
hundredweight (short)	45.35924	kilogram (kg)
kilogram	1000.*	gram (g)
kilogram	35.27397	ounce (avoirdupois)
kilogram	32.15074	ounce (troy)
kilogram	2.204622	pound (avoirdupois)
kilogram	0.06852178	slug
kilogram	0.0009842064	ton (long)
kilogram	0.001102311	ton (short)
kilogram	0.001*	ton (metric)
kilogram	0.001*	tonne
kilogram	0.01968413	hundredweight (long)
kilogram	0.02204622	hundredweight (short)
kilogram/metre <sup>3</sup>	0.06242797	pound/foot <sup>3</sup>
kilogram/metre <sup>3</sup>	0.01002242	pound/gallon (UK liquid)
kilogram/metre <sup>3</sup>	0.008345400	pound/gallon (US liquid)
ounce (avoirdupois)	28.34952	gram (g)
ounce (avoirdupois)	0.02834952	kilogram (kg)
ounce (troy)	31.10348	gram (g)
ounce (troy)	0.03110348	kilogram (kg)
pound (avoirdupois)	0.4535924	kilogram (kg)
pound/foot <sup>3</sup>	16.01846	kilogram/metre <sup>3</sup> (kg/m <sup>3</sup> )

Multiply	By	To Obtain
<b>Mass and Density (Continued)</b>		
pound/inch <sup>3</sup>	27.67990	gram/centimetre <sup>3</sup> (g/cm <sup>3</sup> )
pound/gal (US liquid)	119.8264	kilogram/metre <sup>3</sup> (kg/m <sup>3</sup> )
pound/gal (UK liquid)	99.77633	kilogram/metre <sup>3</sup> (kg/m <sup>3</sup> )
slug	14.59390	kilogram (kg)
ton (long 2240 lb)	1.016.047	kilogram (kg)
ton (short 2000 lb)	907.1847	kilogram (kg)
ton (metric)	1,000.*	kilogram (kg)
tone	1,000.*	kilogram (kg)
<b>Force and Force / Length</b>		
Dyne	0.00001*	newton (N)
kilogram - force	9.806650*	newton (N)
kilopond	9.806650*	newton (N)
newton	0.1019716	kilogram - force
newton	0.1019716	kilopond
newton	0.2248089	pound - force
newton	100.000.*	dyne
newton	7.23301	poundal
newton	3.596942	ounce - force
newton/metre	0.005710148	pound/inch
newton/metre	0.06852178	pound/foot
ounce - force	0.2780139	newton (N)
pound - force	4.448222	newton (N)
poundal	0.1382550	newton (N)
pound/inch	175.1268	newton/metre (N/m)
pound/foot	14.59390	newton/metre (N/m)
<b>Moment of Inertia and Section Modulus</b>		
moment of inertia (kg.m <sup>2</sup> )	23.73036	pound - foot <sup>2</sup>
moment of inertia (kg.m <sup>2</sup> )	3.417.171	pound - inch <sup>2</sup>
moment of inertia (lb.ft <sup>2</sup> )	0.042.14011	kilogram - metre <sup>2</sup> (kg.m <sup>2</sup> )
moment of inertia (lb.inch <sup>2</sup> )	0.0002926397	kilogram - metre <sup>2</sup> (kg.m <sup>2</sup> )
moment of section (foot <sup>4</sup> )	0.008630975	metre <sup>4</sup> (m <sup>4</sup> )
moment of section (inch <sup>4</sup> )	41.62314	centimetre <sup>4</sup>
moment of section (metre <sup>4</sup> )	115.8618	foot <sup>4</sup>
moment of section (centimetre <sup>4</sup> )	0.02402510	inch <sup>4</sup>
section modulus (foot <sup>3</sup> )	0.02831685	metre <sup>3</sup> (m <sup>3</sup> )
section modulus (inch <sup>3</sup> )	0.00001638706	metre <sup>3</sup> (m <sup>3</sup> )
section modulus (metre <sup>3</sup> )	35.31466	foot <sup>3</sup>
section modulus (metre <sup>3</sup> )	61,023.76	inch <sup>3</sup>

Multiply	By	To Obtain
<b>Bending Moment or Torque</b>		
dyne - centimetre	0.0000001.*	newton - metre (N-m)
kilogram - metre	9.806650.*	newton - metre (N-m)
ounce - inch	7.061552	newton - millimetre
ounce - inch	0.007061552	newton - metre (N - m)
newton - metre	0.7375621	pound - foot
newton - metre	10,000,000.*	dyne - centimetre
newton - metre	0.1019716	kilogram - metre
newton - metre	141.6119	ounce - inch
newton - millimetre	0.1416119	ounce - inch
pound - foot	1.355818	newton - metre (N-m)
<b>Momentum</b>		
kilogram - metre/second	7.233011	pound - foot/second
kilogram - metre/second	86.79614	pound - inch/second
pound - foot/second	0.1382550	kilogram - metre/second (kg.m/s)
pound - inch/second	0.01152125	kilogram - metre/second (kg.m/s)
<b>Energy and Work</b>		
Btu (International Table)	1,055.056	joule (J)
Btu (mean)	1,055.87	joule (J)
calorie (mean)	4.19002	joule (J)
foot - pound	1.355818	joule (J)
foot - poundal	0.04214011	joule (J)
joule	0.0009478170	Btu (International table)
joule	0.0009470863	Btu (mean)
joule	0.2386623	calorie (mean)
joule	0.7375621	foot - pound
joule	23.73036	foot - poundal
joule	0.9998180	joule (International US)
joule	0.9999830	joule (US legal, 1948)
joule (International US)	1.000182	joule (J)
joule (US legal, 1948)	1.000017	joule (J)
joule	0002777778	watt - hour
watt - hour	3600.*	joule (J)

Multiply	By	To Obtain
<b>Pressure and Stress</b>		
atmosphere (14.6959 lb/inch <sup>2</sup> )	101,325	pascal (Pa)
bar	100,000.*	pascal (Pa)
bar	14.50377	pounds/inch <sup>2</sup>
bar	100,000.*	newton/metre <sup>2</sup> (N/m <sup>2</sup> )
hectobar	0.6474898	ton (long)/inch <sup>2</sup>
kilogram/centimetre <sup>2</sup>	14.22334	pounds/inch <sup>2</sup>
kilogram/metre <sup>2</sup>	9.806650*	newton/metre <sup>2</sup> (N/m <sup>2</sup> )
kilogram/metre <sup>2</sup>	9.806650*	pascal (Pa)
kilogram/metre <sup>2</sup>	0.2048161	pound/foot <sup>2</sup>
kilonewton/metre <sup>2</sup>	0.1450377	pound/inch <sup>2</sup>
newton/centimetre <sup>2</sup>	1.450377	pound/inch <sup>2</sup>
newton/metre <sup>2</sup>	0.00001*	bar
newton/metre <sup>2</sup>	1.0*	pascal (Pa)
newton/metre <sup>2</sup>	0.0001450377	pound/inch <sup>2</sup>
newton/metre <sup>2</sup>	0.1019716	kilogram/metre <sup>2</sup>
newton/millimetre <sup>2</sup>	145.0377	pound/inch <sup>2</sup>
pascal	0.00000986923	atmosphere
pascal	0.00001*	bar
pascal	0.1019716	kilogram/metre <sup>2</sup>
pascal	1.0*	newton/metre <sup>2</sup> (N/m <sup>2</sup> )
pascal	0.02088543	pound/foot <sup>2</sup>
pascal	0.0001450377	pound/inch <sup>2</sup>
pound/foot <sup>2</sup>	4.882429	kilogram/metre <sup>2</sup>
pound/foot <sup>2</sup>	47.88026	pascal (PA)
pound/inch <sup>2</sup>	0.06894757	bar
pound/inch <sup>2</sup>	0.07030697	kilogram/centimetre <sup>2</sup>
pound/inch <sup>2</sup>	0.6894757	newton/centimetre <sup>2</sup>
pound/inch <sup>2</sup>	6.894757	kilonewton/metre <sup>2</sup>
pound/inch <sup>2</sup>	6,894.757	newton/metre <sup>2</sup> (N/m <sup>2</sup> )
pound/inch <sup>2</sup>	0.006894757	newton/millimetre <sup>2</sup> (N/m <sup>2</sup> )
pound/inch <sup>2</sup>	6,894.757	pascal (Pa)
ton (long)/inch <sup>2</sup>	1.544426	hectobar

Multiply	By	To Obtain
<b>Power</b>		
Btu/Hour (International Table)	0.2930711	watt (W)
foot-pound/hour	0.0003766161	watt (W)
foot-pound/minute	0.02259697	watt (W)
horsepower (550 ft-lb/s)	0.7456999	kilowatt (kW)
horsepower (500 ft-lb/s)	745.6999	watt (W)
horsepower (electric)	746.*	watt (W)
horsepower (metric)	735.499	watt (W)
horsepower (UK)	745.70	watt (W)
Kilowatt	1.341022	horsepower (550 ft - lb/s)
watt	2,655.224	foot-pound/hour
watt	44.25372	foot-pound/minute
watt	0.001341022	horsepower (550 ft-lb/s)
watt	0.001340483	horsepower (electric)
watt	0.001359621	horsepower (metric)
watt	0.001341022	horsepower (UK)
watt	3.412141	Btu/Hour (International Table)
<b>Viscosity</b>		
centipose	0.001*	pascal-second (Pa.s)
centistoke	0.000001*	metre <sup>2</sup> /second (m <sup>2</sup> /s)
metre <sup>2</sup> /second	1,000,000.*	centistoke
metre <sup>2</sup> /second	10,000.*	stoke
pascal-second	1000.*	centipose
pascal-second	10.*	poise
poise	0.1*	pascal-second (Pa.s)
stoke	0.0001.*	metre <sup>2</sup> /second (m <sup>2</sup> /s)
<b>Temperature</b>		
temperature Celsius, tC	temperature Kelvin,tK	$tK = tC + 273.15$
temperature Fahrenheit,tF	temperature Kelvin,tK	$tK = tF + 459.67/1.8$
temperature Celsius,tC	temperature Fahren,tF	$tF = 1.8 tc + 32$
temperature Fahrenheit,tF	temperature Celsius,tC	$tC = tF - 32/1.8$
temperature Kelvin,tK	temperature Celcius,tC	$tC = tK - 273.15$
temperature Kelvin,tK	temperature Fahren,tF	$tF = 1.8 tK - 459.67$
temperature Kelvin,tK	temperature Rankine,tR	$tR = 9/5 tK$
temperature Rankine tR	temperature Kelvin,tK	$tK = 5/9 tR$

Formula For	Word Formula	Formula
<b>Fluid Pressure</b> (In Pounds/Square Inch)	<b>Pressure</b> = $\frac{\text{Force (pounds)}}{\text{Unit Area (Square Inches)}}$	$P = \frac{F}{A}$ or $\text{psi} = \frac{F}{A}$
<b>Cylinder Area</b> (In Square Inches)	<b>Area</b> = $\pi \times \text{Radius}^2$ (Inches) = $\frac{\pi}{4} \times \text{Diameter}^2$ (Inches)	$A = \pi r^2$ $A = \frac{\pi D^2}{4}$ or $A = 0.785 D^2$
<b>Cylinder Force</b> (In Pounds, Push or Pull)	<b>Force</b> = <b>Pressure (psi)</b> x <b>Net Area (Square Inches)</b>	$F = \text{psi} \times A$ or $F = PA$
<b>Cylinder Velocity or Speed</b> (In Feet/Second)	<b>Velocity</b> = $\frac{231 \times \text{Flow Rate (gpm)}}{12 \times 60 \times \text{Net Area (Square Inches)}}$	$v = \frac{231}{720A}$ or $v = \frac{0.3208}{A}$
<b>Cylinder Volume Capacity</b> In Gallons of Fluid	<b>Volume</b> = $\frac{\pi \times \text{Radius}^2 \text{ (Inches)} \times \text{Stroke (Inches)}}{231}$ = $\frac{\text{Net Area (Square Inches)} \times \text{Stroke (Inches)}}{231}$	$V = \frac{\pi r^2 L}{231}$ $V = \frac{AL}{231}$
<b>Cylinder Flow Rate</b> In Gallons per minute	<b>Flow Rate</b> = $\frac{12 \times 60 \times \text{Velocity (feet/sec)} \times \text{Net Area (Square Inches)}}{231}$	$Q = \frac{720vA}{231}$ or $Q = 3.11 vA$
<b>Fluid Motor Torque</b> (In Inch Pounds)	<b>Torque</b> = $\frac{\text{Pressure (psi)} \times \text{Displacement (cu.in,rev)}}{2\pi}$ = $\frac{\text{Horsepower} \times 63025}{\text{rpm}}$ = $\frac{\text{Flow Rate (gpm)} \times \text{Pressure (psi)} \times 36.77}{\text{rpm}}$	$T = \frac{\text{psi } d}{2\pi}$ or $\frac{pd}{2\pi}$ $T = \frac{63025 \text{ HP}}{n}$ $T = \frac{36.77 QP}{n}$ or $T = \frac{36.77 Q \text{ psi}}{n}$
<b>Fluid Motor Torque</b> (100 psi in Inch Pounds)	<b>Torque /100psi</b> = $\frac{\text{FM Displacement (Cu, Inches/Rev)}}{0.0628}$	$T/100 \text{ psi} = \frac{d}{0.0628}$
<b>Fluid Motor Speed</b> (In Rev/Min)	<b>Speed</b> = $\frac{231 \times \text{Flow Rate (gpm)}}{\text{FM Displacement (Cu, In/Rev)}}$	$n = \frac{231 Q}{d}$
<b>Fluid Motor Power</b> (In Horsepower Output)	<b>Horsepower Input</b> = $\frac{\text{Torque Output (Inches/Pounds)} \times \text{rpm}}{63025}$	$HP = \frac{Tn}{63025}$
<b>Pump Outlet Flow</b> In Gallons/min	<b>Flow</b> = $\frac{\text{rpm} \times \text{Pump Displacement (Cu, In/Rev)}}{231}$	$Q = \frac{nd}{231}$
<b>Pump Input Power</b> (In Horsepower Required)	<b>Horsepower</b> = $\frac{\text{Flow Rate Output (gpm)} \times \text{Pressure (psi)}}{1714 \times \text{Efficiency (Overall)}}$	$HP = \frac{QP}{1714 \text{ Eff}}$ or $\frac{\text{gpm} \times \text{psi}}{1714 \text{ Eff}}$
<b>Flow Rate Through Piping</b> (In Feet/second Velocity)	<b>Velocity</b> = $\frac{0.3207 \times \text{Flow Rate through ID (gpm)}}{\text{Internal Area (square inches)}}$	$v = \frac{0.3207Q}{A}$
<b>Compressibility 1/2% Of Oil</b>	<b>Additional Volume</b> = $\frac{\text{Pressure (psi)} \times \text{Volume of Oil Under Pressure}}{250,000}$	$V_a = \frac{PV}{250,000}$ Approx. 1/2% per 1000 psi
<b>Flow</b> In Gallons/min	<b>Flow</b> = $\text{Flow Coefficient} \times \sqrt{\frac{\text{Pressure Drop}}{\text{Specific Gravity}}}$	$Q = CA \times \sqrt{\frac{P1 - P2}{Sg}}$
<b>Flow</b> (Cu, Ft, Sec)	<b>Flow</b> = $\frac{\text{Orifice Coefficient} \times \text{Area (sq.ft)} \times \sqrt{2 \times \text{Press Head (ft)} \times \text{Specific Gravity}}}{\text{Specific Gravity}}$	$Q = CA \times \sqrt{2HSg}$
<b>Heat Dissipation</b> (Btu/hr)	<b>Cooling Capacity</b> = $2 \times T_o - T_a \times \text{Area of Reservoir (sq. ft)}$	$\text{Btu/hr} = 2 \text{ deltaTA}$

# WEBTEC 2018

## Hydraulic test equipment



January							
M	T	W	T	F	S	S	
1	2	3	4	5	6	7	1
8	9	10	11	12	13	14	2
15	16	17	18	19	20	21	3
22	23	24	25	26	27	28	4
29	30	31					5

February							
M	T	W	T	F	S	S	
			1	2	3	4	5
5	6	7	8	9	10	11	6
12	13	14	15	16	17	18	7
19	20	21	22	23	24	25	8
26	27	28					9

March							
M	T	W	T	F	S	S	
			1	2	3	4	9
5	6	7	8	9	10	11	10
12	13	14	15	16	17	18	11
19	20	21	22	23	24	25	12
26	27	28	29	30	31		13

April							
M	T	W	T	F	S	S	
						1	13
2	3	4	5	6	7	8	14
9	10	11	12	13	14	15	15
16	17	18	19	20	21	22	16
23	24	25	26	27	28	29	17
30							18

sales-us@webtec.com

Hydraulic measurement and control

www.webtec.com

# WEBTEC 2018

## Hydraulic components



May							
M	T	W	T	F	S	S	
	1	2	3	4	5	6	18
7	8	9	10	11	12	13	19
14	15	16	17	18	19	20	20
21	22	23	24	25	26	27	21
28	29	30	31				22

June							
M	T	W	T	F	S	S	
				1	2	3	22
4	5	6	7	8	9	10	23
11	12	13	14	15	16	17	24
18	19	20	21	22	23	24	25
25	26	27	28	29	30		26

July							
M	T	W	T	F	S	S	
						1	26
2	3	4	5	6	7	8	27
9	10	11	12	13	14	15	28
16	17	18	19	20	21	22	29
23	24	25	26	27	28	29	30
30	31						31

August							
M	T	W	T	F	S	S	
		1	2	3	4	5	31
6	7	8	9	10	11	12	32
13	14	15	16	17	18	19	33
20	21	22	23	24	25	26	34
27	28	29	30	31			35

sales-us@webtec.com

Hydraulic measurement and control

www.webtec.com

# WEBTEC 2018

## Service and recalibration



September							
M	T	W	T	F	S	S	
					1	2	35
3	4	5	6	7	8	9	36
10	11	12	13	14	15	16	37
17	18	19	20	21	22	23	38
24	25	26	27	28	29	30	39

October							
M	T	W	T	F	S	S	
1	2	3	4	5	6	7	40
8	9	10	11	12	13	14	41
15	16	17	18	19	20	21	42
22	23	24	25	26	27	28	43
29	30	31					44

November							
M	T	W	T	F	S	S	
			1	2	3	4	44
5	6	7	8	9	10	11	45
12	13	14	15	16	17	18	46
19	20	21	22	23	24	25	47
26	27	28	29	30			48

December							
M	T	W	T	F	S	S	
					1	2	48
3	4	5	6	7	8	9	49
10	11	12	13	14	15	16	50
17	18	19	20	21	22	23	51
24	25	26	27	28	29	30	52
31							01

sales-us@webtec.com

Hydraulic measurement and control

www.webtec.com



1290 E. Waterford Ave. Milwaukee, WI 53235, USA  
Toll free: 1-800-932-8378  
Ph: 414-769-6400  
Fax: 414-769-6591

[sales-us@webtec.com](mailto:sales-us@webtec.com)  
[www.webtec.com](http://www.webtec.com)

For Sales & Service, Contact Your Webtec Distributor:





# Safety Burst Discs

Safety burst discs are an integral part of Webtec loading valves, acting as a hydraulic fuse, providing a safe rupture return path for the system fluid. The safety burst discs are precision manufactured, verified devices that are guaranteed to rupture within their tolerance. They protect the meters from accidental over-pressurisation.

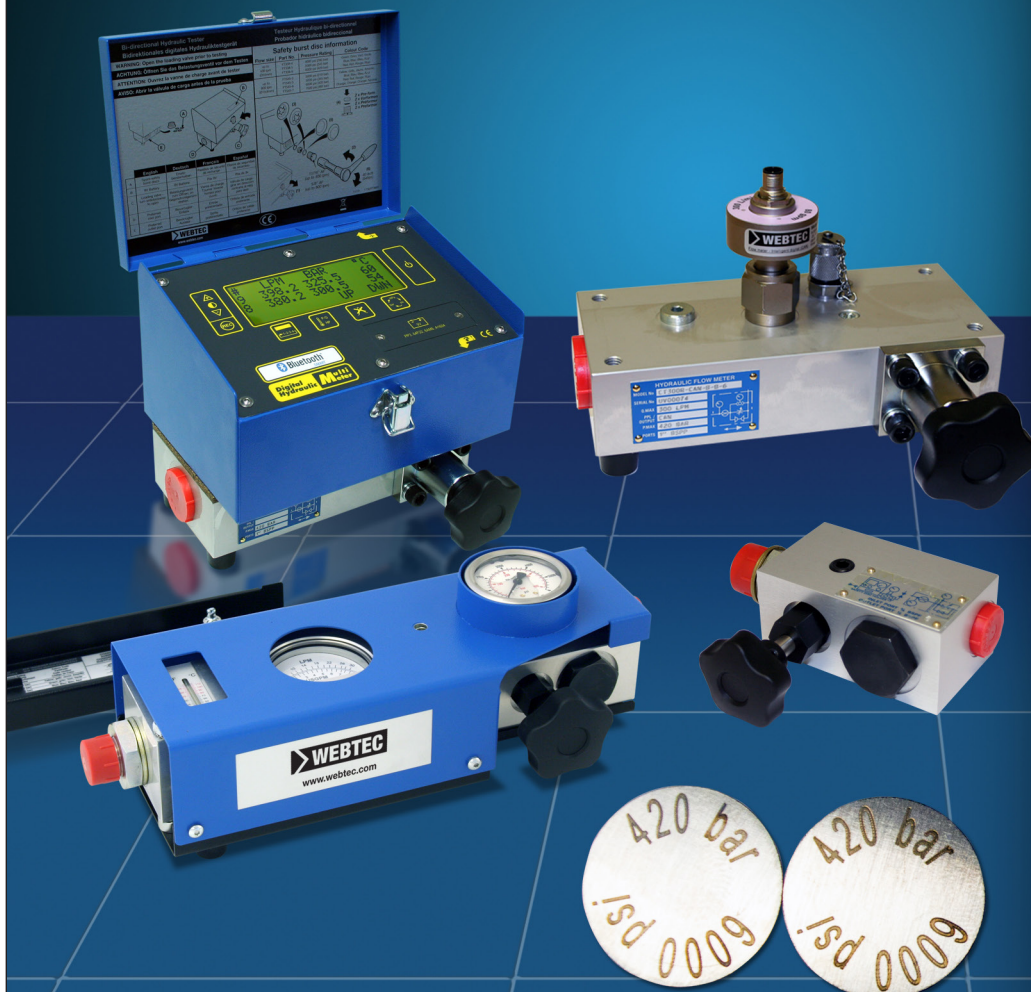

Hydraulic measurement and control



Milwaukee, WI 53235, USA  
Tel: +1 (414) 769-6400  
sales-us@webtec.com

St. Ives, Cambs. PE27 3LZ, UK  
Tel: +44 (0) 1480 397 400  
sales-uk@webtec.com

[www.webtec.com](http://www.webtec.com)

## Features

- Guaranteed to rupture within the specified pressure range.
- Protects the load valve from accidental over-pressurisation.
- Fast and easy to replace.



BURST-BU-ENG-3648.pdf 04/18  
(Issue 2)

## Safety burst disc rupture tolerances

Etched Identification	psi tolerance	bar tolerance
1000 psi 70 bar	-0% / +10%	-1.5% / +8.5%
2000 psi 140 bar	-0% / +10%	-1.5% / +8.5%
3000 psi 210 bar	-0% / +10%	-1.5% / +8.5%
4000 psi 280 bar	-0% / +10%	-1.5% / +8.5%
5000 psi 345 bar	-0% / +10%	-0% / +10%
6000 psi 420 bar	-0% / +10%	-1.5% / +8.5%
7000 psi 480 bar	-0% / +10%	+0.5% / +10.5%

NB. Burst disc ratings at 22°C

The fluid operating temperature affects when the safety burst discs' rupture, a high temperature reduces the expected failure pressure. The % changes from nominal burst pressure are summarised below:

Fluid Temperature	40°C 104°F	50°C 122°F	60°C 140°F	70°C 158°F	80°C 176°F	90°C 194°F	100°C 212°F
Disc Ø19.8mm-S.S 1.4044	-3.2%	-5.2%	-7.0%	-8.0%	-9.6%	-11.3%	-12.9%
Disc Ø16mm-Nickel 2.4066	-2.2%	-3.3%	-4.5%	-5.2%	-6.1%	-7.1%	-8.1%

NB. This data is estimated from physical tests and should be considered as a guide.

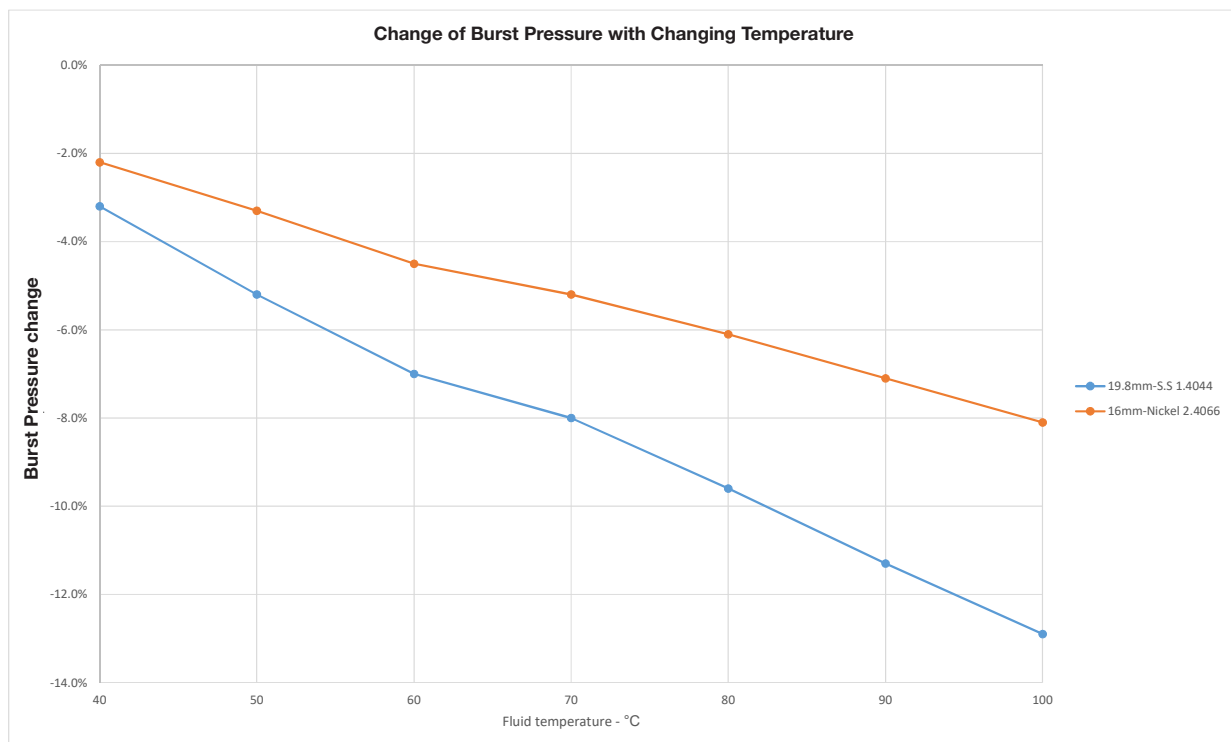

## Safety burst disc

Flow Size/Model	Part No. (PK of 10)	Nominal rating	Colour
up to 400lpm 100USgpm (Ø16mm) HV1500 (Ø16mm)	FT10791-1	1000 psi, 70 bar	White
	FT10791-2	2000 psi, 140 bar	Brown
	FT10791-3	3000 psi, 210 bar	Yellow
	FT10791-4	4000 psi, 280 bar	Green
	FT10791-5	5000 psi, 345 bar	Blue
	FT10791-6	6000 psi, 420 bar	Red
	FT10791-7	7000 psi, 480 bar	Orange
>400lpm up to 800lpm 210USgpm (Ø19.8mm)	FT10792-3	3000 psi, 210 bar	Yellow
	FT10792-5	5000 psi, 345 bar	Blue
	FT10792-6	6000 psi, 420 bar	Red
	FT10792-7	7000 psi, 480 bar	Orange

NB. Colour is being phased out.

# SR & Intelligent Digital (CAN) sensors and accessories for use with HPM Series

Up to

- 750 lpm, 200 US gpm flow measurement
- 1000 bar, 14500 psi pressure measurement

## Wide range of cables and accessories

All Intelligent Digital (ID) sensors use the CAN protocol and feature a LED to enable easy identification. The SR sensors also have identification built in so the handsets can recognise the type and size of sensor being used.

There is a wide range of cables and connectors to suit all applications. The ID sensors are connected in-line with one another, by way of a Y cable, often resulting in shorter cable lengths.

The CT and CTR series of turbine flow meters, provide a complete solution to the flow and temperature measurement of hydraulic systems on test stands, machine tools and other fixed or mobile applications. The flow meter can be installed anywhere in the hydraulic circuit for production testing, commissioning, development testing and control systems. The compact design allows the flow meters to be installed where space is limited.

The integral loading valve built into the CTR series provides smooth progressive pressure control in both flow directions allowing components such as cylinders or motors to be tested without re-plumbing the test connections.

The pressure sensors are available in six different ranges up to 1000 bar and all measure temperature as well. The whole unit is housed in a stainless steel body, sealed to IP67.

600 bar ID pressure transducer

ID connection cable

ID Y cable

ID termination resistor



Hydraulic measurement and control



Milwaukee, WI 53235, USA

Tel: +1 (414) 769-6400

sales-us@webtec.com

St. Ives, Cambs. PE27 3LZ, UK

Tel: +44 (0) 1480 397 400

sales-uk@webtec.com

www.webtec.com

## Features

### Flowmeters

- **FLOW:** – 1 -750 lpm  
0.25 - 200 US gpm
- **PRESSURE:** Upto  
480 bar, 7000 psi
- **PORTING:** BSPP or SAE  
BI directional operation

### Flowmeters with Loading Valve

- **FLOW:** – 1 -750 lpm  
0.25 - 200 US gpm
- **PRESSURE:** Upto  
480 bar, 7000 psi
- **PORTING:** BSPP or SAE
- **BI DIRECTIONAL**  
operation 'INTERPASS™'  
safety system, bypasses  
oil internally in the event  
of valve being over  
pressurised
- **FLOWMETER**  
**TEMPERATURE:**  
-25 to 125°C (-13 to 257 °F)

### Pressure transducers

- **PRESSURE:** -1 to 1000  
bar (-14.5 to 14500 psi)
- **TEMPERATURE:** -25 to  
105 °C (-13 - 221 °F)

### Accessories

- **CABLES:** 0.5 to 20 meter  
long

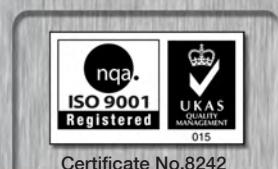

HPMACC-BU-ENG-2699.pdf 06/14  
(Issue 13)

# Flowmeters

## Specifications

Model Number	Main ports	Top ports*	Flow range	Max. pressure
CT15-***-B-B-6	1/2" BSPP	1/4" BSPP	1 - 15 lpm	420 bar
CT15-***-S-S-6	3/4" -16UN #8 SAE ORB	7/16" -20UN #4 SAE ORB	0.25 - 4 US gpm	6000 psi
CT60-***-B-B-6	3/4" BSPP	1/4" BSPP	3 - 60 lpm	420 bar
CT60-***-S-S-6	1-1/16" -12UN #12 SAE ORB	7/16" -20UN #4 SAE ORB	0.8 - 16 US gpm	6000 psi
CT150-***-B-B-6	3/4" BSPP	1/4" BSPP	5 - 150 lpm	420 bar
CT150-***-S-S-6	1-1/16" -12UN #12 SAE ORB	7/16" -20UN #4 SAE ORB	1.3 - 40 US gpm	6000 psi
CT300-***-B-B-6	1" BSPP	1/4" BSPP	8 - 300 lpm	420 bar
CT300-***-S-S-6	1-5/16" -12UN #16 SAE ORB	7/16" -20UN #4 SAE ORB	2 - 80 US gpm	6000 psi
CT600-***-B-B-5	1-1/4" BSPP	1/4" BSPP	15 - 600 lpm	350 bar
CT600-***-S-S-5	1-5/8" -12UN #20 SAE ORB	7/16" -20UN #4 SAE ORB	4 - 160 US gpm	5000 psi
CT750-***-S-B-7	1-7/8" -12UN #24 SAE ORB	1/4" BSPP	20 - 750 lpm	480 bar
CT750-***-S-S-7	1-7/8" -12UN #24 SAE ORB	7/16" -20UN #4 SAE ORB	5 - 200 US gpm	7000 psi
CT750-SR-F-B-3 SR	1-1/2" #24 SAE Code 61 4-bolt flange	1/4" BSPP	20 - 750 lpm	210 bar
CT750-SR-F-S-3 SR	1-1/2" #24 SAE Code 61 4-bolt flange	7/16" -20UN #4 SAE ORB	5 - 200 US gpm	3000 psi

Replace \*\*\* with CAN or SR to give complete model number. \*CT 15 has one of the specified top ports.

Dimensions in mm (inches)

Model Number	A	B	C	D	E	Weight kg (lbs)
CT15	37 (1-1/2")	136 (5-3/8")	37 (1-1/2")	123 (5")	69.5 (2-3/4")	0.7 (1.5)
CT60	62 (2-1/2")	190 (7-1/2")	50 (2")	136 (5-3/8")	103 (4")	1.6 (3.5)
CT150	62 (2-1/2")	190 (7-1/2")	50 (2")	136 (5-3/8")	103 (4")	1.6 (3.5)
CT300	62 (2-1/2")	190 (7-1/2")	50 (2")	140 (5-1/2")	103 (4")	1.7 (3.7)
CT400	62 (2-1/2")	190 (7-1/2")	50 (2")	140 (5-1/2")	103 (4")	1.7 (3.7)
CT600	62 (2-1/2")	212 (8-3/8")	75 (3")	156 (6")	127 (5")	2.7 (6)
CT600-**-F-**-*	100 (4")	212 (8-3/8")	75 (3")	160 (6-1/4")	126 (5")	5.0 (11)
CT750	100 (4")	212 (8-3/8")	75 (3")	160 (6-1/4")	126 (5")	5.0 (11)

SR version is 9mm (3/8") shorter on the D dimensions

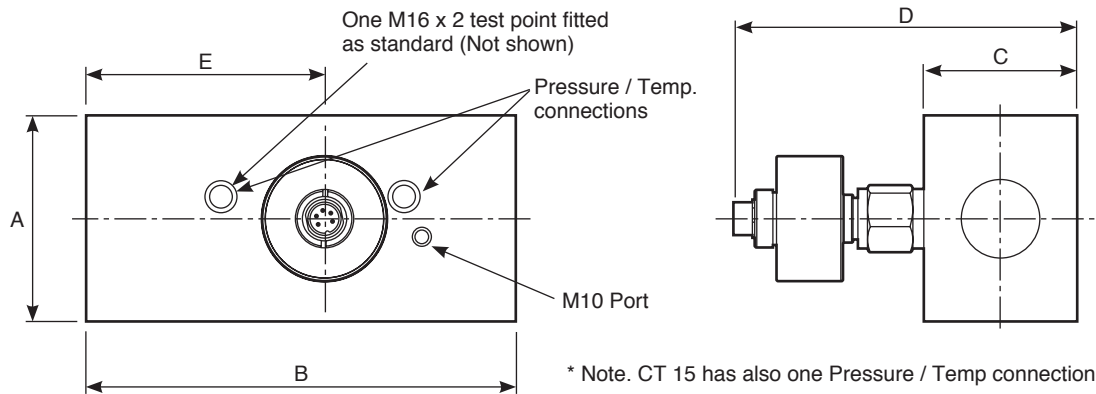

# Flowmeters with loading valve

## Specifications

Model Number	Main ports	Top ports	Flow range	Max. pressure
CT300R-***-B-B-6	1" BSPP	1/4" BSPP	8 - 300 lpm	420 bar
CT300R-***-S-S-6	1-5/16" -12UN #16 SAE ORB	7/16" -20UN #4 SAE ORB	2 - 80 US gpm	6000 psi
CT600R-SR-F-B-3	1-1/2" #24 SAE Code 61 4-bolt flange	1/4" BSPP	20 - 600 lpm	210 bar
CT600R-SR-F-S-3	1-1/2" #24 SAE Code 61 4-bolt flange	7/16" -20UN #4 SAE ORB	5 - 160 US gpm	3000 psi
CT600R-SR-S-B-7	1-7/8" -12UN #24 SAE ORB	1/4" BSPP	20 - 600 lpm	480 bar
CT600R-SR-S-S-7	1-7/8" -12UN #24 SAE ORB	7/16" -20UN #4 SAE ORB	5 - 160 US gpm	7000 psi
CT750R-***-S-B-7	1-7/8" -12UN #24 SAE ORB	1/4" BSPP	20 - 750 lpm	480 bar
CT750R-***-S-S-7	1-7/8" -12UN #24 SAE ORB	7/16" -20UN #4 SAE ORB	5 - 200 US gpm	7000 psi
CT750R-SR-F-B-3	1-1/2" #24 SAE Code 61 4-bolt flange	1/4" BSPP	20 - 750 lpm	210 bar
CT750R-SR-F-S-3	1-1/2" #24 SAE Code 61 4-bolt flange	7/16" -20UN #4 SAE ORB	5 - 200 US gpm	3000 psi

Replace \*\*\* with CAN or SR to give complete model number.

Dimensions in mm (inches)

Model No	A	B	C	D	E	F	G	Weight kg (lbs)
CT300R	49 (2")	100 (4")	182 (7-1/8")	222 (8-3/4")	102.5 (4")	47.6 (1-7/8")	138 (5-1/2")	3.7 (8.1)
CT400R	49 (2")	100 (4")	182 (7-1/8")	222 (8-3/4")	102.5 (4")	47.6 (1-7/8")	138 (5-1/2")	3.7 (8.1)
CT600R	75 (3")	125 (5")	211 (8-3/8")	235 (9-3/4")	99 (3-7/8")	63 (2-1/2")	157 (6-1/8")	7.5 (16.5)
CT750R	75 (3")	125 (5")	211 (8-3/8")	235 (9-3/4")	99 (3-7/8")	63 (2-1/2")	157 (6-1/8")	7.5 (16.5)

Add 20mm (3/4") to G for full height including feet.

SR version is 9mm (3/8") shorter on the G dimensions

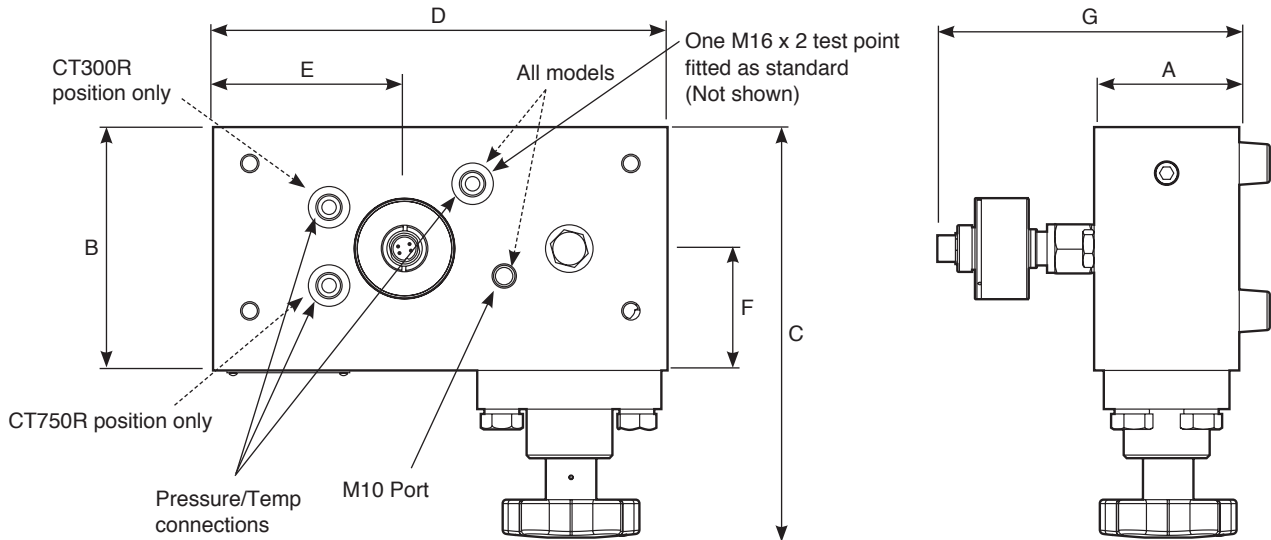

### Functional specification

#### CT and CTR flow meters

##### Ambient temperature:

-10 to 50 °C (14 - 122 °F)

##### Fluid type:

Oils, fuels, water glycol, water oil emulsions

##### Fluid temperature:

-20 to 90 °C (-4 - 194 °F) continuous use.

##### Filtration

25 µm (10 µm for CT15-CAN)

##### Viscosity range

10...100 cSt

##### Temperature display:

-25 to +125 °C (-13 to +257 °F). NB. CAN flow transducers only.

##### Accuracy:

15 to 100% of range - 1% of indicated reading  
Below 15% fixed accuracy of 1% of 15% of full scale (CT15 is 1% of full scale)  
Temperature ± 2 °C (CAN only).

##### Repeatability:

Better than ± 0.2%

##### Degree of protection\*:

CT-SR – IP54 (EN60529)  
CT-CAN – IP66 (EN60529) \*With cable connected

### Electrical specification

##### Power supply:

CAN: 8 - 40 VDC, SR: 7-15 VDC

##### Response Time:

50 ms

### Construction material

##### Flow body:

600/750 High tensile Aluminium 2014A T6  
15/60/150/300/400 High tensile Aluminium 2011 T6

##### Internal parts:

Aluminium, Steel, Stainless Steel.

##### Transducer:

Body and nut - steel 212A42 electroless nickel plated, Housing and Lid - Aluminium 2011 T3

##### Seals:

Viton seals as standard EPDM are available - please consult sales office.

## Pressure Transducers

### CAN (ID)

Model Number	Pressure range
SR-PT*-016-05-0C-CAN	-1 - 16 bar
SR-PT*-060-05-0C-CAN	0 - 60 bar
SR-PT*-160-05-0C-CAN	0 - 160 bar
SR-PT*-400-05-0C-CAN	0 - 400 bar
SR-PT*-600-05-0C-CAN	0 - 600 bar
SR-PT*-1K0-05-0C-CAN	0 - 1000 bar

### SR

Model Number	Pressure range
SR-PT*-015-05-0C	-1 - 15 bar
SR-PT*-060-05-0C	0 - 60 bar
SR-PT*-150-05-0C	0 - 150 bar
SR-PT*-400-05-0C	0 - 400 bar
SR-PT*-600-05-0C	0 - 600 bar
SR-PT*-1K0-05-0C	0 - 1000 bar

Replace \* with 'N' for no temperature and with 'T' for unit with temperature. Supplied with M16 x 2 test point connector

#### SR-PTN-\*\*\*-0C-CAN

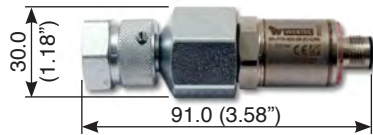

#### SR-PTN-\*\*\*-05-0C



#### SR-PTT-\*\*\*-0C-CAN



#### SR-PTT-\*\*\*-05-0C

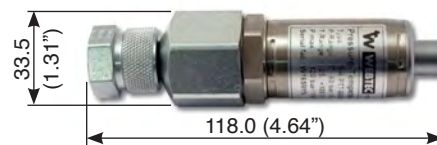

### Functional specification

<b>Ambient temperature:</b>	-25 to 85 °C (-13 - 185 °F)
<b>Fluid type:</b>	Oils, fuels, water glycol, water oil emulsions
<b>Fluid temperature:</b>	-25 to 105 °C (-13 - 221 °F)
<b>Accuracy:</b>	Pressure: ± 0.5% full scale Temperature: ± 3 °C (SR-PTT-* ONLY)

### Electrical specification

<b>Power supply:</b>	CAN: 8 - 40 VDC SR: 7-15 VDC SR
<b>Response Time:</b>	1 ms

### Construction material

<b>Main body:</b>	Stainless steel 1.4301
<b>Sealing:</b>	Viton® (FKM)
<b>Degree of protection*:</b>	SR – IP54 (EN60529) CAN – IP66 (EN60529) *With cable connected

<b>Wetted parts:</b>	Stainless steel 1.4301, Viton® (FKM)
<b>Dimensions:</b>	95.6 mm x 26.9 mm
<b>Weight approx.:</b>	170 g

### CAN (ID) Connection cables

Model Number	Length
SR-CBL-0.5-MF-CAN	0.5m
SR-CBL-02-MF-CAN	2m
SR-CBL-05-MF-CAN	5m
SR-CBL-10-MF-CAN	10m
SR-CBL-20-MF-CAN	20m
SR-CBL-0.05-Y-CAN	Splitter no cable
SR-CBL-0.3-Y-CAN	CAN Y splitter, including 0.3 m cable
SR-CBL-000-R-CAN	CAN terminating resistor
SR-CONN-ADPT-M8	Cable adapter M8x1 4pol Digital IN/OUT
SR-CONN-ADPT-M12	Cable adapter M12x1 5pol analog

### SR Cables

Model Number	Length	Type
SR-CBL-003-55-MM	3m	Connecting
SR-CBL-005-55-MM	5m	Extension
SR-CBL-002-54-MM	2m	Adaptor 5 to 4 pin

### Accessories / spares

Model Number	Description
SR-PSU-HPM6000	HPM6000 power pack
SR-HPM6000-00-0C-STP	HPM6000 neck strap
SR-CAB-540-PC-USB	HPM540 PC Cable to USB
SR-USB-HPM6000	USB cable type A to B
SR-LAN-HPM6000	LAN cable
SR-HPM-PSU-MC-1C	Power supply for HPM540
SR-HPM-CHG-03-0C	In car charger adaptor
SR-HAND-HPM6000	Replacement handle for HPM6000

### Other sensors & accessories

Model Number	Description
SR-RPM-300-05-3C	SR Tach with 5 pin fixed cable
SR-RPM-WHL-00-0C	Tach contact wheel
SR-RPM-ADP-00-0C	Focus adaptor
SR-EXT-TRG-05-1C	External trigger box
SR-VADC-1C	SR Sensor input box and cable
SR-FQC	SR frequency converter
SR-TTP-190-05-0C	SR Temperature transducer -40 to 150 °C 1/4" BSPP
SR-TTP-190-05-0C	CAN Temperature transducer -40 to 150 °C 1/4" BSPP



APPROVED