

APX™ TWO-WAY RADIOS



APX 7500 MULTI-BAND CONSOLETTTE SYSTEM PLANNER



Manual Revisions

Changes which occur after this manual is printed are described in PMRs (Publication Manual Revisions). These PMRs provide complete replacement pages for all added, changed, and deleted items, including pertinent parts list data, schematics, and component layout diagrams.

Computer Software Copyrights

The Motorola products described in this manual may include copyrighted Motorola computer programs stored in semiconductor memories or other media. Laws in the United States and other countries preserve for Motorola certain exclusive rights for copyrighted computer programs, including, but not limited to, the exclusive right to copy or reproduce in any form the copyrighted computer program. Accordingly, any copyrighted Motorola computer programs contained in the Motorola products described in this manual may not be copied, reproduced, modified, reverse-engineered, or distributed in any manner without the express written permission of Motorola. Furthermore, the purchase of Motorola products shall not be deemed to grant either directly or by implication, estoppel, or otherwise, any license under the copyrights, patents or patent applications of Motorola, except for the normal non-exclusive license to use that arises by operation of law in the sale of a product.

Documentation Copyrights

No duplication or distribution of this document or any portion thereof shall take place without the express written permission of Motorola. No part of this manual may be reproduced, distributed, or transmitted in any form or by any means, electronic or mechanical, for any purpose without the express written permission of Motorola.

Disclaimer

The information in this document is carefully examined, and is believed to be entirely reliable. However no responsibility is assumed for inaccuracies. Furthermore, Motorola reserves the right to make changes to any products herein to improve readability, function, or design. Motorola does not assume any liability arising out of the applications or use of any product or circuit described herein; nor does it cover any license under its patent rights nor the rights of others.

Trademarks

MOTOROLA, MOTO, MOTOROLA SOLUTIONS and the Stylized M logo are trademarks or registered trademarks of Motorola Trademark Holdings, LLC and are used under license. All other trademarks are the property of their respective owners.

© 2012 by Motorola Solutions, Inc.

The AMBE+2™ voice coding Technology embodied in this product is protected by intellectual property rights including patent rights, copyrights and trade secrets of Digital Voice Systems, Inc.

This voice coding Technology is licensed solely for use within this Communications Equipment. The user of this Technology is explicitly prohibited from attempting to decompile, reverse engineer, or disassemble the Object Code, or in any other way convert the Object Code into a human-readable form.

U.S. Pat. Nos. #5,870,405, #5,826,222, #5,754,974, #5,701,390, #5,715,365, #5,649,050, #5,630,011, #5,581,656, #5,517,511, #5,491,772, #5,247,579, #5,226,084 and #5,195,166.

Section 1 *Introduction*

1.1 Welcome to APX™ 7500 Multi-Band Consolette	1
1.2 Software Version	2

Section 2 *Consolette Capabilities to Consider for Your Applications*

2.1 Remote Control Capability	3
2.2 Channel Selection	3
2.3 Signaling Types and RF Band Support	4
2.4 Duty Cycle	4
2.5 Functionality	4

Section 3 *Feature Comparison*

3.1 Consolette Overview	7
3.2 Front Panel Functionality	8
3.3 Rear Panel Functionality	9
3.4 General	10

Section 4 *Supported Features*

4.1 Powering the Consolette	11
4.1.1 AC and DC Power Inputs	11
4.1.2 Power On/Off	11
4.2 O5 Control Head (L999_ Required)	12
4.3 Limited Feature Front Panel (L998_)	12
4.4 Keypad Operation (L999_ Required)	12
4.5 Front Panel Microphone (L999_ Required)	12
4.6 Auxiliary GCAI Connector	12
4.7 Front Panel Speaker (L999_ Required)	13
4.8 Auxiliary Display Operation	13
4.9 Softmenu Buttons on the Auxiliary Display	13
4.10 Clock Operation	14
4.11 VU Meter Operation	14
4.12 Speaker Mute Operation (L999_ Required)	14
4.13 Front Panel Programmable Buttons	15
4.14 Emergency Alarm Decode	15
4.15 Wireline Interface	16
4.15.1 E&M with Wireline	16
4.15.2 Tone Remote Control Operation	16
4.15.2.1 TRC Supported Functionality	17
4.15.2.2 Tone Tables on the Wireline Interface	18

4.15.3 ACIM Interface	19
4.15.3.1 System Overview.....	19
4.15.3.2 Supported Functionality:.....	20
4.16 MCD 5000 Interface	24
4.17 Headsets (L999_ Required)	25
4.17.1 Operation	25
4.18 PTT Footswitch (L999_ Required)	25
4.19 Crosspatch	26
4.19.1 Connection	26
4.20 APCO Interface	26
4.21 Over-the-air Alert Tones Operation (L999_ Required).....	27
4.22 Battery (AC Power Fail) Alert Tone Operation	27
4.23 Revert to Low RF Power Operation	27
4.24 Recorder Operation.....	28
4.25 External PA Operation.....	28
4.25.1 Firehouse Day/Night switch	28
4.26 VIP Operation.....	28
4.26.1 VIP Inputs.....	29
4.26.2 VIP Outputs.....	29
4.27 External Speaker.....	30
4.28 Audio Jack.....	30
4.29 Crossmute Operation	30
4.29.1 Connection and Operation	31
4.30 Emergency	31

Section 5 *Programming Applications*

5.1 Programming the Console.....	33
5.1.1 PC and Network Requirements.....	33
5.1.1.1 PC requirements for APX CPS	33
5.1.1.2 PC requirements for On Board Configuration Application	33
5.1.1.3 Network security requirements for On Board Configuration Application	33
5.1.1.4 Network Performance for On Board Configuration Application	34
5.1.2 APX CPS Codeplug Programming.....	34
5.1.3 Controller Card Configuration using a Web Browser	34
5.1.3.1 Establishing a connection to the Console.....	34

Section 6 *Ordering Guide*

6.1 Ordering steps.....	37
6.2 Ordering Options	37

6.2.1 Required Options	37
6.2.1.1 Step 1: APX 7500 Console Main Model	37
6.2.1.2 Step 2: Operation Mode	37
6.2.1.3 Step 3: System Enhancement Software	38
6.2.1.4 Step 3B: System Enhancement Software.....	38
6.2.1.5 Step 4: Front Panel Configuration	38
6.2.1.6 Step 5: Microphones.....	38
6.2.1.7 Step 6: Power Cords.....	38
6.2.2 Optional Features.....	39
6.2.3 Aftermarket Accessories	39
6.3 Ordering Examples.....	40
6.3.1 Example 1	40
6.3.2 Example 2	41
 Section 7 <i>Recommended Cabling</i>	
 Section 8 <i>Specifications</i>	
8.1 APX 7500 Project 25 Multi-Band Console.....	45
8.1.1 Transmitter Specification.....	45
8.1.2 Receiver Specification.....	46
8.1.3 Power and Battery Specification	46
8.1.4 Regulatory Certifications	47
8.1.5 Environmental Specification.....	47
8.1.6 FCC Certification ID	47
8.1.7 General	48
8.1.8 Others	48
 Section 9 <i>Commercial Warranty</i>	
9.1 Limited Warranty	51
9.1.1 MOTOROLA COMMUNICATION PRODUCTS	51
9.1.1.1 What This Warranty Covers And For How Long.....	51
 Section 10 <i>Acronyms And Definitions</i>	
10.1 Terms and Definitions	55
 Section 11 <i>Frequently Asked Questions (FAQ)</i>	
11.1 Questions and Answers	57
 Section A <i>Replacement Parts Ordering</i>	
A.1 Basic Ordering Information	61
A.2 Motorola Online.....	61

A.3 Mail Orders	61
A.4 Telephone Orders	61
A.5 Fax Orders	61
A.6 Parts Identification	61
A.7 Product Customer Service	62
A.8 Motorola System Support Center (SSC)	62

SECTION 1 INTRODUCTION

1.1 Welcome to APX™ 7500 Multi-Band Console

The Motorola APX™ 7500 Multi-Band Console is the next generation Console design that incorporates the APX 7500 mobile transceiver and the O5 control head to complement Motorola's APCO PHASE II dual band product line.

The Console is a key device in many Motorola voice systems offering a low cost RF control station solution to customers that are within a communication system and want a wireless dispatch solution. The Console is also used as an emergency backup station when the infrastructure is off-line, as a low cost dispatch center for federal, state and local agencies, and as a fire station alerting system.

The APX 7500 Console is available in the 7/800MHz, VHF, UHF R1, and UHF R2 bands (mid power models only). Configurations include both the limited front panel and the full featured front panel (contains the O5 control head). Rear panel interfaces include: Tone Remote Control (TRC), ACIM, Ethernet and E&M (Ear and Mouth) for interfacing to remote consoles and desksets such as the MC 2000, the MCC 5500, Gold Series Elite Console, MCD 5000 and the MCC 7500.

All models are equipped with an internal AC to DC power supply and support Battery Revert operation. Additionally there is an auxiliary display with corresponding soft menus and status indications for support of a VU Meter and Clock.

In addition to the above mentioned functionality, the APX 7500 Console supports the following functionality via its rear panel: recorder interface, connection for up to 2 headsets, interface for connection of an external PA, connection for a second speaker, and a crosspatch interface.

1.2 Software Version

All the features described in the System Planner are supported by the APX 7500 Console with controller board software version **R02.00.00** and above.

SECTION 2 CONSOLETTA CAPABILITIES TO CONSIDER FOR YOUR APPLICATIONS

The Consolette is a mid-tier offering between the lower tier Mobile Control Station (typically referred to as a Mobile-in-a-tray) and the higher tier complete base station and zone controller system. There are 4 main distinguishing factors to consider when selecting your Consolette configuration.

2.1 Remote Control Capability

Customers may require the user controls of the unit to be remotely located from the transceiver which may be in a separate equipment room. Both the Consolette and the full zone controller system allow for remote control; the Mobile-in-a-tray does not.

- NOTE:** 1) The Mobile-in-a-tray can be combined with an external Tone Remote Adaptor and Tone Remote Deskset to allow for limited remote control capability.
2) Typically the Consolette is located such that the antenna cable length is minimized.

Remote Control setups have trade-offs with installation distance between the transceiver and the remote user. In addition, the distance to the antenna should be also taken into consideration.

- E&M remote control – cable length is 5 feet maximum
- TRC control – allows for long distances, but requires conditioned leased lines
- ACIM control – this is an RS232 interface and is limited to 50 feet

NOTE: Error correcting modems can be added to extend this distance.

- MCD 5000 control – 100 meters with direct Ethernet connection, unlimited over IP network.

2.2 Channel Selection

Customers may require the ability to access multiple channels in the transceiver. If local control is required, both the Consolette and Mobile-in-a-tray allow access to all channels in the transceiver via the O5 control head. In the APX 7500, this is currently 1250 channels.

If remote control is required, then the number of channels accessible to the remote user depends on the remote control method:

- Mobile-in-a-tray with an external tone remote adaptor and tone deskset will allow access to 1 channel only.
- The Consolette supports E&M, TRC, MCD 5000 and ACIM remote control.
 - E&M control allows user access to 1 channel only
 - TRC control allows user access to 16 channels
 - ACIM control allows user access to 255 channels using the MCC 7500/CCGW
 - MCD 5000 control allows user access to the full channel capability of the radio (ex. 1250)

2.3 Signaling Types and RF Band Support

Customers may require interoperability between different systems within a single transceiver.

Both the Consolette and the Mobile-in-a-tray are capable of the full suite of signaling types in each unit including: Analog (including MDC), ASTRO Conventional, Type II Trunking, APCO Trunking (including Phase 2 TDMA). Similarly the Consolette and the Mobile-in-a-tray are capable of dual band operation allowing the user the ability to communicate on one band, then change channels and communicate on another band.

2.4 Duty Cycle

Both the Consolette and the Mobile-in-a-tray are rated for the EIA/TIA Intermittent Duty Cycle (this is a 1 minute transmit, 4 minute receive duty cycle). A 100% continuous duty cycle is not supported.

2.5 Functionality

The following chart contains additional information regarding the functionality trade-offs of the various interfaces of the Consolette:

Table 2.1 Types of Connection between APX 7500 Consolette and Remote Console

Feature at Remote	E&M Interface	TRC	ACIM (AIS over RS232)	ACIM (AIS over RS232)	Ethernet Interface
Remote Console Models supported	MCC 7500, CENTRACOM, Gold Series Elite, MCC5500, Command Star Lite, MIP5000	MCC 7500, CENTRACOM, Gold Series Elite, MCC5500, Command Star Lite, MC 2000, MIP 5000, MCD 5000	Gold Series Elite, MCC5500	MCC 7500 with CCGW (GGM8000)	MCD 5000
Distance allowed between Consolette and remote	5 feet	infinite (wireline)	50 feet*	50 feet*	infinite (network)
Maximum number of radio channels that can be accessed from the remote	1	14 (Gold Elite) 16	8 (Gold Elite) 16 (MCC 5500)	255	1250
Emergency ID Decode supported (Alarm and Call) at Remote	No	No	Yes; alarm and call	Yes; alarm and call	Yes; alarm and call
PTT ID Aliasing at Remote	No	No	Yes; cross referenced at Console	Yes; cross referenced at Console	Yes

Feature at Remote	E&M Interface	TRC	ACIM (AIS over RS232)	ACIM (AIS over RS232)	Ethernet Interface
Extended Dispatch Operation (Option GA00469A): - Status/Message Update Decode - Status Request Encode - Radio Enable/Disable Encode - Radio Check Encode - Remote Monitor Encode	No	No	Yes; on conventional signalling types only.	Yes; on conventional signalling types only.	No
Emergency Alarm ACK Encode	No	No	Yes; conventional only	Yes; conventional only	Yes; conventional only
Conventional Call Alert Encode	No	No	Yes; on conventional signalling types only	Yes; on conventional signalling types only	Yes; on conventional and trunking signalling

NOTE: This is the distance to the CCGW and/or ACIM card. Error correcting modems can be added to extend this distance.

Notes

SECTION 3 FEATURE COMPARISON

The APX 7500 Consolette is available in two different front panel styles: Limited Front Panel (option L998_) or Full Featured Front Panel (option L999_). The following comparison shows the differences between the two styles.

3.1 Consolette Overview



Figure 3-1 APX™ 7500 Consolette Full Feature Front Panel (L999_)



Figure 3-2 APX™ 7500 Consolette Limited Front Panel (L998_)

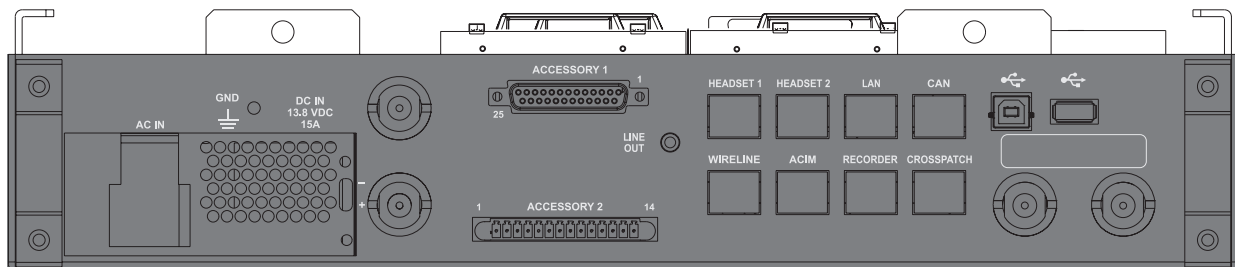

Figure 3-3 APX™ 7500 Consolette Back Panel

3.2 Front Panel Functionality

Features (requires appropriate options ordered)	APX™ 7500 Console Full Feature Front Panel (L999_)	APX™ 7500 Console Limited Front Panel (L998_)
Local Control Head Supported	√	No
GCAI Paddle mic supported	√	No
Internal local speaker	√	No
Clock	√	√
VU Meter	√	√
Auxiliary Display	√	√
Numeric Keypad	√	No
Programmable Buttons	√	Limited to 3 programming buttons
External Keyload Port	√	√
External Programming Port(s)	√	√
External IV&D Port	√	√
Tactical OTAR Port	√	√
Control head on/off switch	√	No

3.3 Rear Panel Functionality

Features (requires appropriate options ordered)	APX™ 7500 Consolette Full Feature Front Panel (L999_)	APX™ 7500 Consolette Limited Front Panel (L998_)
TRC* with Wireline	√	√
E&M* with Wireline	√	√
ACIM* with Wireline	√	√
MCD 5000** via Ethernet	√	√
APCO Interface	√	√
Crosspatch Interface	√	√
Crossmute Interface	√	√
Recorder	√	√
Auxiliary Audio Jack	√	√
Auxiliary External Mobile speaker	√	√
Headset Interface (2)	√	No
General Purpose Inputs/ Outputs	√	√
Emergency Footswitch	√	√

* Wireline features TRC, ACIM, and E&M operation are mutually exclusive. Eg. if TRC enabled, then ACIM and E&M with Wireline are disallowed

** Operation requires MCD 5000 software R2.0 or later and APX Controller board software R2.0 or later. MCD 5000 via Ethernet operation is mutually exclusive with other remote control interfaces including TRC and ACIM. Eg. if MCD 5000 operation is enabled, then TRC and ACIM are disallowed.

NOTE: Local control including Headset operation is not allowed on limited feature configuration.

3.4 General

Features (requires appropriate options ordered)	APX™ 7500 Consolette Full Feature Front Panel (L999_)	APX™ 7500 Consolette Limited Front Panel (L998_)
Power supply with battery revert	√	√
AC Power on/off switch	√	√
Intermittent Duty Cycle (EIA/ TIA)	√	√
Dual Band supported	√	√

NOTE: Legacy desksets MC 3000 and DGT 9000s are not supported.

SECTION 4 SUPPORTED FEATURES

4.1 Powering the Consolette

4.1.1 AC and DC Power Inputs

The Consolette is intended for connection to an AC wall outlet. It supports an internal power supply that accepts an AC input of 110-220VAC 50-60Hz via a standard IEC 320 power inlet. The power supply is auto switching so setting of an internal switch for 110VAC or 220VAC operation is not required. An AC power cord ships with each Consolette. Refer to Section 6.2.1.7 for information on the cable styles available for the various countries.

The Consolette also supports a connection to a DC battery. This functionality is standard, ordering a separate DC option is not required. It supports a DC input of 13.8VDC +/- 10%. An optional DC power cable with an inline 20 amp fuse can be ordered with each Consolette. The Consolette does not provide charging capabilities on this connection. Refer to Section 4.22 for information regarding an AC Power Fail alert when powered using DC.

The Consolette provides an LED on the front panel to indicate when it is operating on AC power or DC power.

4.1.2 Power On/Off

The Consolette can be powered on/off in four different ways:

- Factory Default settings and using AC: Apply AC to the unit, then move the I/O switch on the rear panel to the I setting. The unit will now power up and remain on as long as AC is present. When AC is interrupted, the unit will turn off. When AC is restored, the unit will power back on.
 - Factory Default settings and using DC: Apply DC to the unit. The unit will now power up and remain on as long as DC is present. The position of the I/O switch has no effect on the DC input. When DC is interrupted, the unit will turn off. When DC is restored, the unit will power back on.
 - Factory Default settings and using both AC and DC: The unit will power up once DC power is supplied. It will automatically switch to AC if present when the I/O switch is set to the I setting. When AC is interrupted, the unit will automatically revert to using the DC source. When AC is restored, the unit will then automatically revert to using the AC source again without interruption in operation.
 - Codeplug set by user to enable the on/off button on the O5 control head: Reprogram the Consolette to enable the O5 control head On/Off button. Apply AC (or DC) to the unit, then move the I/O switch on the rear panel to the I setting. The unit will remain off until the user presses the On button on the O5 control head. Press the On button on the O5 control head and the unit will now power up. In the event AC is interrupted (and DC not present), the unit will turn off. When AC is restored, the unit will power back on. When the O5 control head On/Off button is enabled and AC power is lost and then restored the unit will revert to the state it was in before the AC power interruption (On or Off).
-

4.2 O5 Control Head (L999_ Required)

The Consolette can be ordered with the Full Featured Front Panel (L999_ option) which includes an O5 control head. Refer to the O5 User's Guide (6875947M01) for information regarding all of the features of the radio that can be accessed from the O5 control head.

4.3 Limited Feature Front Panel (L998_)

Some users may only have an operator at a remote deskset/console position and want to ensure that no one tampers with the Consolette. A limited feature front panel (option L998) is available where the O5 control head, the numeric keypad, and the speaker are not present.

Functions such as TRC Interface, ACIM Interface and MCD 5000 Interface continue to operate in this configuration unlike past Consolette models. Microphone and Headset connections are intended to be made at the remote deskset/console position.

4.4 Keypad Operation (L999_ Required)

On models with the full feature front panel, the Consolette contains a standard 3x4 numeric keypad for interaction with the O5 control head. The digits follow the keypad microphone layout and are marked with numeric (0-9, *, #) and alpha-numeric characters. The primary purpose of this keypad is for dialing, etc, through the radio.

4.5 Front Panel Microphone (L999_ Required)

A paddle mic (RMN5070) can be used with the Consolette. It connects to the GCAI connector on the O5 control head. The paddle mic supports a microphone and two functions: monitor enable/disable and transmit enable/disable.

4.6 Auxiliary GCAI Connector

The Consolette is equipped with a GCAI connector on the front panel in addition to the one on the O5 control head. The primary purpose for this Auxiliary GCAI is keyloading and mobile programming.

4.7 Front Panel Speaker (L999_ Required)

Models with the O5 present also contain an internally housed speaker. Receive audio, tones, and remote transmit audio are present at this speaker. The audio loudness can be controlled by the rotary volume knob on the O5 control head.

The normal operation of the front panel speaker can be overridden by:

- connection of a Headset to the Consolette
- activation of the MUTE_IN signal to the rear of the Consolette
- activation of the Speaker Mute Button from the front panel

4.8 Auxiliary Display Operation

The Consolette comes equipped with an auxiliary display to supplement the display provided by the O5 control head. It supports a Clock, a VU Meter, icons representing the state of Consolette features, soft menus with custom labels, and text updates indicating the state of Consolette features.



Figure 4-1 Auxiliary Display

4.9 Softmenu Buttons on the Auxiliary Display

The Consolette supports three buttons underneath its auxiliary display for accessing up to eight softmenus. These softmenus are used to activate or control certain Consolette features. Each supports a custom label on the display that can be programmed by the user. The label may consist of up to five printable US-ASCII characters. Consolette features currently supported via the soft menu are:

- Crosspatch Enable/Disable
- Auxiliary Control Enable/Disable
- Over-the-Air Alert Tones (L999_ Required)
- Setup functions including Clock Set and IP Address View

4.10 Clock Operation

The Consolette supports a Clock on its auxiliary display for displaying the current time. The clock shows hours and minutes and can be configured for 12 hour format or 24 hour format. It can also be disabled completely. In 12 hour format an AM/PM indication is shown. The clock feature does not provide the date, or seconds resolution.

Setting the clock is accessed through the SETUP softmenu underneath the auxiliary display.

Timekeeping is done by the RTC circuitry on the controller card within the Consolette. Optionally, the time can be retrieved from the NTP server when connected to the network.

The Consolette now contains a battery backup circuit for use with the Clock. If power is completely interrupted to the Consolette, the internal coin cell battery will maintain the time. Once power is restored to the Consolette, the display will show the time and not need to be reset by the user. The Consolette ships from the factory with a coin cell installed. It is a CR2032 or equivalent battery size and is rated for a nominal voltage of 3.0 Volts.

4.11 VU Meter Operation

The Consolette supports a VU Meter on its auxiliary display. The VU Meter is a bar-graph representation of the audio level on the currently selected transmit audio input. The VU Meter can be enabled/disabled using the onboard Consolette Configuration application.

4.12 Speaker Mute Operation (L999_ Required)

The Consolette supports a Speaker Mute button on units with a control head present. This button can be used to mute the front panel speaker for a programmable duration or until the button is pressed again.

When the Speaker Mute button is activated, its backlight will change to red as an indicator to the operator. Also, an icon on the auxiliary display is shown to indicate when the speaker is muted.

There are audio interactions between the Speaker Mute button and some rear panel inputs including: the Headset and the Mute_In* input (Crossmute feature). When the Headset is attached, the local speaker is automatically muted and the Speaker Mute button is disabled for as long as the Headset is attached. Additionally, if the Mute_In* signal on the rear of the Consolette is activated, the local speaker is automatically muted.

The Consolette can be configured to have the Speaker Mute button disabled.

4.13 Front Panel Programmable Buttons

The Consolette supports three programmable buttons on units with a control head present. These are located underneath the Speaker Mute Button. These three buttons may be assigned to either Radio or Consolette functions.

When configured for Radio Functions, the functionality that can be programmed onto these buttons is the same as that defined in the APX CPS for the Keypad Mic programmable sidebuttons.

Consolette functionality that may be assigned to the dedicated buttons currently includes:

- Crosspatch Enable/Disable
- Auxiliary Control Enable/Disable
- Over-the-Air Alert Tones

NOTE: There is no softmenu or label support on the auxiliary display to indicate the functionality of these buttons.

4.14 Emergency Alarm Decode

The Consolette supports Emergency Alarm decode on MDC Conventional, ASTRO Conventional, Type II Trunking and APCO P25 Trunking signaling types. Using APX CPS, the Consolette can be configured to display the ID on the attached O5 control head (if present), sound an alert tone, and activate a general purpose output when an Emergency Alarm is decoded.

NOTE: The Consolette's transceiver can only detect trunking Emergency Alarms when on the control channel. If the Consolette is on a voice channel, it will not be able to decode the control channel and will miss the Emergency Alarm. This feature is not recommended for high usage systems where the Consolette is the only device decoding the alarms.

IDs can also be provided to the ACIM interface. New with the APX 7500 Consolette is the ability to generate an Emergency ACK in response to the Emergency Alarm via its ACIM interface. Refer to the ACIM Section 4.15.3 for further details.

IDs can also be provided to the MCD 5000 interface. The APX Consolette has the ability to generate an automatic Emergency ACK in response to receiving the Emergency Alarm. Refer to the MCD 5000 Section 4.16 for further details.

4.15 Wireline Interface

The Consolette supports a balanced Wireline Interface on a dedicated RJ45 on its rear panel.

The Wireline supports:

- 2-wire or 4-wire operation
- 600-ohm loading or open bridge on both the receive and transmit paths

This interface can be used in conjunction with an E&M interface, Tone Remote Control, or ACIM interface.

4.15.1 E&M with Wireline

E&M operation is provided by the Wireline Interface in conjunction with:

- Hardware PTT – an input to the rear panel DB25 that when asserted by an external device causes the Consolette to transmit the audio that is currently on the wireline path.
- Chan_Act_Relay_Out – a rear panel DB25 output of a normally open onboard relay which closes (and routes rear panel DB25 relay input Chan_Act_Relay_In) when the Consolette is receiving qualified audio.

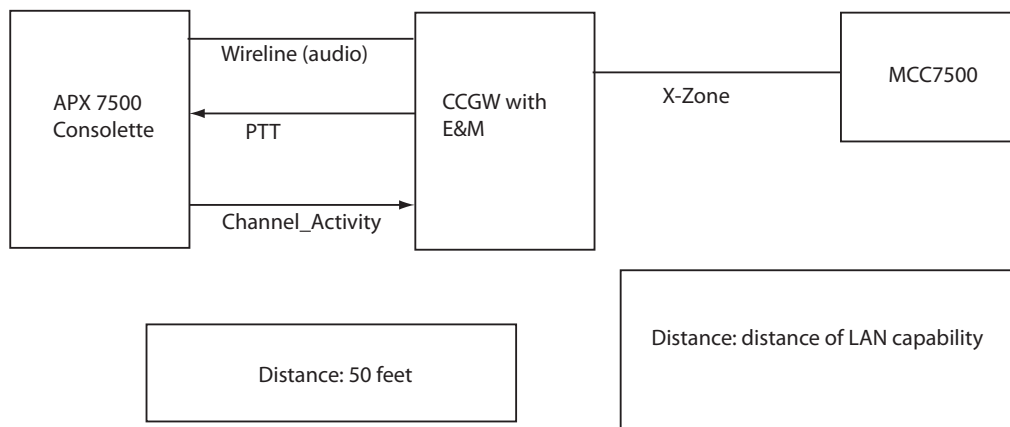

Figure 4-2 APX 7500 Consolette to MCC7500 topology

4.15.2 Tone Remote Control Operation

The Wireline Interface can be used in conjunction with a Tone Remote Control (TRC) Deskset or Console. The Consolette supports the following remote control functionality via Tone Remote Control:

- Channel Select
- Secure On/Off
- PTT Press/Release
- Monitor
- Receive Voice
- Transmit Voice
- ID Reporting

- NOTE:** 1) Enabling and disabling Scan operation is not supported from a Tone Remote Deskset
 2) When TRC is selected, the ACIM link will also be enabled for received call and ID reporting only.

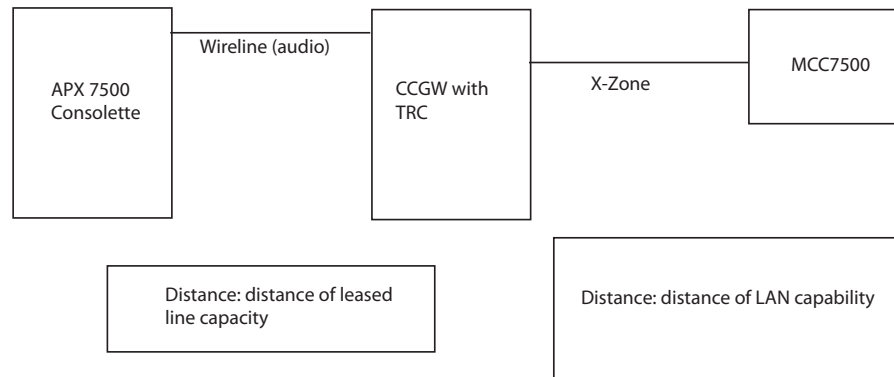

Figure 4-3 APX 7500 Consolette to MCC7500 topology

4.15.2.1 TRC Supported Functionality

Channel – The dispatch console user uses the Select Frequency command to change the Consolette’s radio channel. This will select items such as a talk group and an air interface type. The number of channels that can be changed by the dispatcher is 14.

NOTE: Selection of 16 channels is possible if the tone table is set up to not use Coded/Clear operation.

When a Select Frequency command is received from the Console, the Consolette will send a message to the mobile radio to steer it to the channel requested. The channel number from the Console is mapped linearly to a zone and channel in the mobile radio. For example, if each zone has 5 channels, and the Console requests channel 8, the Consolette will steer the mobile to channel 3 in zone 2. If the mobile does not allow the indicated channel, the Consolette will generate a “bonk” tone and remain in the current channel.

NOTE: The Consolette is capable of 1250 channels and these can be accessed from the O5 control head.

Coded/Clear – When a coded or clear (encryption on or off) command is received, the Consolette will send a message to the mobile radio to set encryption to the indicated state. If the mobile does not allow the indicated encryption state on the current channel, the Consolette will generate a “bonk” tone and remain in the prior state.

PTT – To make a voice transmission, first select the desired channel using the Select Frequency feature. Then the console user also ensures that the correct secure mode (if configured) is chosen.

NOTE: For encrypted voice calls, the Console sends the request for secure mode to the Consolette so the Consolette can encrypt the audio. The Console does not encrypt the audio associated with coded mode calls.

Once all of the selections are made the console user invokes a PTT to start their transmission. The requested transmission is then performed by the Consolette which routes audio from the wireline TX interface to the radio for transmit. The transmission goes out on the currently selected air interface (and talk group if one is chosen) using the unit ID of the Consolette's radio (not the Console's unit ID). Once the LLGT is no longer detected by the Consolette or if the Console operator dekeys, the Consolette will dekey. AGC can be enabled on this interface. If the mobile configuration does not allow the PTT (RX Only Channel for example) or if any of the Channel/Coded/Clear commands included in the PTT sequence are disallowed, the Consolette will generate a "bonk" tone and not Key Up.

Monitor – When a monitor command is received, the Consolette will send a message to the mobile radio to cause it to enter the monitor state (ex. disables Receive PL on Conventional channels). Whenever a subsequent PTT command ends, a message is sent to exit the monitor state.

Receiving a Voice Transmission – When the Consolette receives a voice transmission, the audio is provided on the wireline RX interface to the Console. There is no ID reporting available with the TRC interface. If ID reporting is needed, refer to section 4.20 for information regarding the use of an external MDC decoder or section 4.15.3 for information regarding the ACIM interface.

Sending a Voice Transmission – When the Console/Deskset sends a voice transmission, the audio is provided to the wireline TX interface of the Consolette. AGC can be enabled for the transmit audio on t

4.15.2.2 Tone Tables on the Wireline Interface

The Consolette now supports customer configuration of the TRC tone tables. The Consolette also supports additional guard tone and function tone frequencies.

Supported High Level Guard Tone (HLGT) frequencies include:

- 2100 Hz
- 2175 Hz
- 2300 Hz
- 2325 Hz

Supported range of function tone frequencies include: 450Hz to 2050Hz in 100Hz increments. The frequencies can be mapped to the supported functions. The Consolette supports pre-defined tone tables and also allows the user to customize the tone table with any desired assignment of functions to tones. The pre-defined tables currently supported are:

Function Tone	Standard Table	CentraCom II	No Mode	Mode 1 Only	No Mode 1
2175 Hz	Guard Tone/PTT	Guard Tone/PTT	Guard Tone/PTT	Guard Tone/PTT	Guard Tone/PTT
2050 Hz	Monitor	Monitor	Monitor	Monitor	Monitor
1950 Hz	Mode 1 Select	Mode 1 Select	No effect	Mode 1 Select	Mode 2 Select
1850 Hz	Mode 2 Select	Mode 2 Select	No effect	No effect	Mode 2 Select
1750 Hz	Mode 7 Select	Mode 7 Select	No effect	No effect	Mode 7 Select
1650 Hz	Mode 8 Select	Mode 8 Select	No effect	No effect	Mode 8 Select

Function Tone	Standard Table	CentraCom II	No Mode	Mode 1 Only	No Mode 1
1550 Hz	Mode 5 Select	Mode 5 Select	No effect	No effect	Mode 5 Select
1450 Hz	Mode 6 Select	Mode 6 Select	No effect	No effect	Mode 6 Select
1350 Hz	Mode 3 Select	Mode 3 Select	No effect	No effect	Mode 3 Select
1250 Hz	Mode 4 Select	Mode 4 Select	No effect	No effect	Mode 4 Select
1150 Hz	Secure Coded Select	Mode 5 Select	Secure Coded Select	Secure Coded Select	Secure Coded Select
1050 Hz	Secure Clear Select	Mode 6 Select	Secure Clear Select	Secure Clear Select	Secure Clear Select

Figure 4-4 Pre-defined Tone Tables

4.15.3 ACIM Interface

4.15.3.1 System Overview

Typical Dispatch Console configurations with Consolette include:

1. Trunking Fall Back Operation – The Consolettes provide communications in the event the main trunking system is no longer accessible to the console. This provides additional communications in the event of the following situations:
 - The situation where a dispatch center has lost communications with the rest of the trunking system.
 - The situation where a trunked RF site is operating in site trunking or failsoft mode.

The trunked Consolettes are located such that they can provide the desired communication capabilities either on the main trunking system or on an RF site. This approach allows the dispatchers to communicate with radio users and to use the various supplemental signaling features that are supported by the Consolette (e.g.,PTT ID, Emergency Alarm).

This scenario requires the customer to have a Conventional Site Controller (CSC) located at the console site so that the console site can operate in Site Conventional mode (see Figure 1). The console site also requires a local CCGW with the ACIM Link connected to the Consolette which is operating on a Trunking air interface. When the console site loses connectivity to the Zone Controller the console site switches to local mode and can still access the CCGW's ACIM Link channel. This allows the dispatcher to access trunking talk groups via the ACIM Link channel.

2. Wireless Access to Different System Types

Customers can use an ACIM Link channel to access system types that they normally do not have regular access to. For instance there may be a local 3600 Trunking system that they want to access but do not have the infrastructure available to do so. They can use an ACIM Link channel with a Consolette to access talk groups on the 3600 Trunking system.

Customers can also use ACIM Link channels to access other systems that the product can interface to but the customer does not have wireline access. For example, accessing an ASTRO conventional channel in a neighboring community.

Additionally, Motorola radio system customers often interact with other organizations during large incidents, joint operations or special events. These interactions often require the dispatchers be able to communicate with the radio users from the other organization.

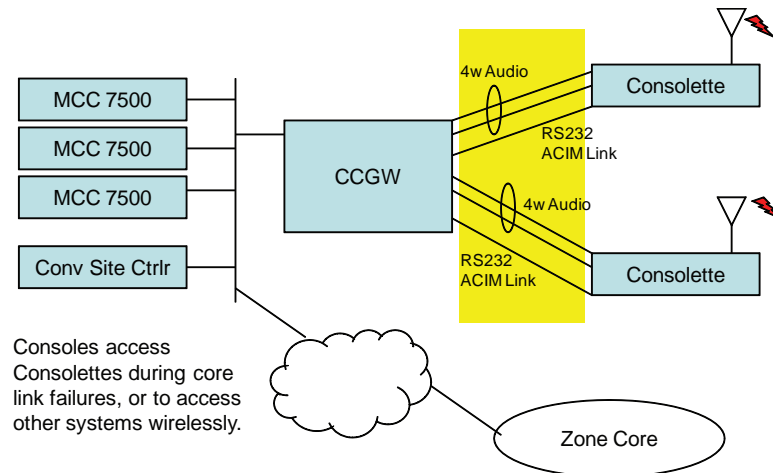

Figure 4-5 MC7500 and CCGW with ACIM Typical System Architecture

4.15.3.2 Supported Functionality:

The Wireline Interface can be used in conjunction with the ACIM Interface. The Wireline is for audio, and the ACIM Interface is for digital control messages. The ACIM interface has a dedicated RJ45 connection on the rear panel. It is an RS232 interface set up for 9600 baud, 8 data bits, no parity, 1 stop bit.

The user may initiate the following commands to a Consolette from a Console via the ACIM interface (or CCGW):

- Channel Select (Console dependent; up to 255 with newer Consoles)
- Secure On/Off
- PTT Press/Release
- Monitor On
- Monitor Off (based on PTT release)
- Encryption Key (CKR) Select*
- Outbound Call Alerts
- Emergency Alarm ACK Encode
- Extended Console Operation (Option GA00469 required)

* Option W969 for Multiple Key Encryption Operation is required for this operation.

Additionally the following information is made available to the Console from a Consolette via the ACIM interface (or CCGW):

- Encryption Key (CKR) Reporting*
- ID Reporting

* Option W969 for Multiple Key Encryption Operation is required for this operation.

NOTE: Enabling and disabling Scan operation is not supported via the ACIM interface.

1. Channel – The dispatch console user uses the Select Frequency command to change the Console's radio channel. This will select items such as a talk group and an air interface type. The number of channels that can be changed by the dispatcher is dependent on the Console. Gold Series Elite has the capability for up to 12 channels. The MCC7500 has the capability for up to 255 channels through the new T255R255 base type.

The Console is capable of 1250 channels and these can be accessed from the O5 control head. When a Select Frequency command is received from the Console, the Console will send a message to the mobile radio to steer it to the channel requested. Note that the channel number from the Console is mapped linearly to a zone and channel in the mobile radio. For example, if each zone has 5 channels, and the Console requests channel 8, the Console will steer the mobile to channel 3 in zone 2. If the mobile does not allow the indicated channel, the Console will generate a "bonk" tone and remain in the current channel.

2. Coded/Clear – When a coded or clear (encryption on or off) command is received, the Console will send a message to the mobile radio to set encryption to the indicated state. If the mobile does not allow the indicated encryption state on the current channel, the Console will generate a "bonk" tone and remain in the prior state.
3. Transmitting Voice – A console user makes a voice transmission on an ACIM Link channel using the same procedures they use on an ASTRO conventional channel. First they ensure that the desired mode is set through the Select Frequency feature. Then the console user also ensures that the correct secure mode and CKR (if configured and coded mode is desired) are chosen. If the mobile configuration does not allow the PTT (RX Only Channel for example) or if any of the Channel/Coded/Clear/CKR commands included in the PTT sequence are disallowed, the Console will generate a "bonk" tone and not Key Up.

NOTE: For encrypted voice calls, the Console sends the request for secure mode and the associated CKR to the Console so the Console can encrypt the audio. The Console does not encrypt the audio associated with coded mode calls.

Once all of the selections are made the console user invokes a PTT (through a mouse click or footswitch) to start their transmission. The requested transmission is then performed by the Console routing audio from the wireline TX interface to the radio for transmit. The transmission goes out on the currently selected air interface (and talk group if one is chosen) using the unit ID of the Console's radio (not the Console's unit ID). Once the PTT Keepup is no longer detected by the Console or if the Console operator dekeys, the Console will dekey.

NOTE: Outbound voice selective calls (ex. Private Calls) are not supported on the ACIM Link.

4. Encryption Key (CKR) Select* – The Console user has the ability to select a specific CKR value to be used during transmit operation. When a CKR select command is received, the Console will send a message to the mobile radio to cause it to use the requested CKR on future transmissions.

* Option W969 for Multiple Key Encryption Operation is required for this operation.

NOTE: If the radio does not allow the indicated encryption state on the current channel, the Console will generate a "bonk" tone and remain in the prior state.

5. Outbound Call Alerts – allows the Console user the ability to transmit a Call Alert to a subscriber on the selected channel. The request is sent from the Console to the Console which will transmit the Call Alert over-the-air to a subscriber. The Call Alert will contain the Console's ID, not the Console's. The corresponding ACK is received by the Console and provided to the Console.

NOTE: Operation on Conventional channels is supported at product launch. Operation on Trunking channels is not supported.

6. Emergency Alarm ACK – A subscriber unit can send an emergency alarm over-the-air at any time. The Consolette will receive it, decode it and provide it to the Console. The corresponding ACK from the Console is then transmitted by the Consolette over-the-air back to the specified subscriber on Conventional channels only. The ACK is auto generated by the system, not user initiated.

NOTE: Emergency Alarm decode is supported on both trunking and conventional air interfaces, but the corresponding ACK is only allowed on conventional air interfaces. It is recommended that only one Consolette per conventional system be enabled to acknowledge alarms. Emergency Alarms on a Trunking air interface are always acknowledged by the Trunking System.

Emergency Alarm ACK Encode is standard on Consolette models beginning with R09.00.00 radio software. Option GA00469 is no longer required for this functionality.

7. Monitor – When a monitor command is received, the Consolette will send a message to the mobile radio to cause it to enter the monitor state (ex. disables Receive PL on Conventional channels). Whenever a subsequent PTT command ends, a message is sent to exit the monitor state.
8. Receiving a Voice Transmission including IDs – When the Consolette receives a voice transmission it is reported via the ACIM Link. The console user will see it as an inbound call on the ACIM Link channel.

The Console GUI may show the alias (or Unit ID) of the source of the transmission if a Unit ID was received with the transmission. The Consolette supports inbound group calls, Voice Selective Calls, Trunking Private Calls and Emergency Calls. Not all air interface types support all inbound voice transmission types.

Note that Voice Selective Calls and Private Calls are only supported locally to the Consolette and are reported to the Console as Group Calls. Only Unit-to-Unit Call Alerts are reported to the MCC7500 Console, Group Call Alerts are not reported.

The following table describes the IDs that are supported:

	Unit-to-Unit Call Alert	PTT-ID*	Emergency Call PTT-ID*	Emergency Alarm PTT-ID
Analog Conventional	Not Reported	Not Reported	Not Reported	Not Reported
Analog Conventional with MDC (Optional)	Reported	Reported	Reported	Reported
APCO Conventional	Reported	Reported	Reported	Reported
Type II Trunking - Analog TG	Reported	Reported	Reported	Reported
Type II Trunking - Digital TG	Reported	Reported	Reported	Reported
ASTRO 25 Trunking	Reported	Reported	Reported	Reported

Figure 4-6 Supported ID

9. Encryption Key (CKR) Reporting* – The Consolette supports receiving encrypted calls in both ASTRO and analog modes. For all air interfaces the Consolette will also report the received CKR which can be displayed on the console GUI. Received encrypted calls are decrypted at the Consolette, not the Console.

* Option W969 for Multiple Key Encryption Operation is required for this operation

10. Inbound Call Alert directed to Console – a subscriber unit can direct a call alert over-the-air to the Console via the Consolette on Conventional APCO and MDC channels. The Consolette will receive it and pass it to the Console. The corresponding ACK will come from the Console to the Consolette and is transmitted over-the-air back to the specified subscriber with the Console's ID.
11. Extended Dispatch Operation – The Consolette supports a set of features needed for typical Console operation. These features are allowed on Analog Conventional with MDC and ASTRO P25 Conventional channels only. The Consolette does not act as a trunked station, and as a result, these features are not supported on Trunking channels. To enable this extended functionality, the Extended Dispatch Operation option (GA00469) must be ordered and the field enabled in the radio CPS for each System. The Console user interface for these messages is the same as its user interface for ASTRO conventional channels.

NOTE: It is recommended that Scan operation not be used simultaneously with the Extended Dispatch functionality. This is to prevent inadvertent responses such as ACKs on a different channel than what the originating message was received on. Responses are transmitted on the selected channel, not the scanned to channel.

4.15.3.2.1 Decode Functionality

When the Consolette receives a supplementary data transmission it is reported via the ACIM Link. The features supported are based on the current selected air interface. The supplementary data messages that can be received are:

- Status Update – a subscriber unit can send a status update over-the-air at any time. The Consolette will receive it, decode it and provide it to the Console. The corresponding ACK from the Console is then transmitted by the Consolette over-the-air back to the specified subscriber.
- Message Update – a subscriber unit can send a message update over-the-air at any time. The Consolette will receive it, decode it and provide it to the Console. The corresponding ACK from the Console is then transmitted by the Consolette over-the-air back to the specified subscriber.

4.15.3.2.2 Encode Functionality

When the Console users wish to transmit a supplementary data message to a subscriber in the field, they do it in the same manner as for ASTRO conventional channels. The request is sent from the Console to the Consolette which will then transmit the supplementary data over-the-air to a subscriber. The features supported by the Consolette are based on the currently selected air interface. The supplementary data messages that can be transmitted are:

- Status Request – allows the Console user the ability to remotely determine a specific subscriber's status.
 - Radio Enable/Disable – allows the Console user the ability to make unusable (Inhibit) a specific subscriber and correspondingly restore a unit to normal operation (Un-Inhibit).
 - Radio Check – allows the Console user the ability to remotely ping a specific subscriber.
 - Remote Monitor – allows the Console user the ability to remotely put a specific subscriber into transmit mode.
-

The corresponding ACK transmitted by the specified subscriber and then received by the Console will be passed up to the Console. The Console retries supplementary data messages when the required acknowledgment is not received in time.

Inbound	Outbound	Type	Analog Conv	MDC Conv	APCO Conv	9600 AP Trk	3600 Ast Trk	3600 AnaTrk
EMER Alarm		ACTLICW	NO	YES	YES	YES	YES	YES
	EMER Alarm ACK*	ACTLICW	NO	YES	YES	NO	NO	NO
Status Update	Status Update ACK	ACTLICW	NO	YES	YES	NO	NO	NO
Msg Update	Msg Update ACK	ACTLICW	NO	YES	YES	NO	NO	NO
Status Query Resp	Status Query	ACTLICW	NO	YES	YES	NO	NO	NO
Radio Monitor ACK	Radio Monitor	ACTLICW	NO	YES	YES	NO	NO	NO
Radio Check ACK	Radio Check	ACTLICW	NO	YES	YES	NO	NO	NO
Subscriber Inhibit ACK	Subscriber Inhibit	ACTLICW	NO	YES	YES	NO	NO	NO
Subscriber Un-Inhibit ACK	Subscriber Un-Inhibit	ACTLICW	NO	YES	YES	NO	NO	NO

Figure 4-7 ACK Transmit

* Option GA00469 no longer required for Emergency Alarm ACK operation.

NOTE: For Trunking Channels the system will Ack the Emergency Alarm

4.16 MCD 5000 Interface

The Console supports connection to an MCD 5000 Deskset System via the LAN connector on the Rear Panel. The MCD 5000 emulates the radio control head (ex. O5 control head) and provides access to the radio's functionality (Eg. Zone/channel displays, softmenus, PTT ID information including alias, icons and TMS). A single MCD 5000 Deskset may be directly connected using a standard CAT5 cable (limit of 100m cable length). Multiple Desksets may be connected, or the distance extended, using an MCD 5000 RGU. Refer to the MCD 5000 System Planner for further details.

Refer to the following MCD 5000 system product manuals for additional information on supported system topologies and setup information:

6802987C94	MCD 5000 Deskset User Guide
6802988C45	MCD 5000 Deskset Quick Start Guide
6802987C54	MCD 5000 Deskset Quick Reference Guide
6802987C53	MCD 5000 RGU Quick Reference Guide
6802987C97	MCD 5000 Deskset System Without OMC Installation & Configuration Guide
6802987C96	MCD 5000 Deskset System With OMC Installation & Configuration Guide
6802987C99	MCD 5000 Deskset System Administrator Control Panel User Guide

Figure 4-8 MCD 5000 System Product Manuals

NOTE: Emergency Alarm ACK Encode is standard on Consolette models beginning with R09.00.00 radio software. Option GA00469 is no longer required for this functionality. The GA00469A Extended Dispatch features are not supported by the MCD 5000 Deskset System.

4.17 Headsets (L999_ Required)

Connections for up to two headsets are provided at the rear panel of the Consolette. The two RJ45 connectors are designed specifically for the Headset Jack Box (FHN7470_) in conjunction with the Headset Amplifier Module Base with PTT switch (CDN6281). One Headset Interface Box is required for each RJ45 headset connector on the Consolette. Standard Plantronics Headsets with phono style plugs can then be plugged into the jack box.

NOTE: 1) The FHN7470_ Headset Jack Box kit includes cable kit (FKN8694A) which is incompatible with the Consolette. This cable must be modified or replaced with a customer supplied 1-to-1 cable between the Jack Box and Consolette Rear Panel Headset connector.
2) Headset connections are only supported on Consolette models with a full featured front panel. They are not active on limited front panel units.

4.17.1 Operation

When a Headset Interface Box is connected to the rear panel, the Consolette will mute the front panel speaker. When receive audio is present from the radio, the Consolette routes the audio to both headsets. The user can control the level of audio to the headset speakers by adjusting the volume control knob on the O5 control head. When the PTT signal from either headset is pressed, the microphone audio from the two headsets are combined and sent to the radio for transmit operation.

4.18 PTT Footswitch (L999_ Required)

The Consolette provides two Headset connections one of which can be used with a PTT Footswitch for hands free operation. A headset is connected to one of the RJ45 Headset connectors to provide the microphone audio and speaker audio signals. The Footswitch is then connected to the other RJ45 Headset connector. The user would have to modify the footswitch connector to attach to the Consolette. Refer to the Consolette manual for pinout information.

Signals include:

- HDSTx_PTT - This is a logic input to cause the radio to transmit. The radio will transmit when this input is pulled to less than 0.8VDC to ground.

NOTE: Enabling/Disabling Monitor is not supported on this interface.

4.19 Crosspatch

The Consolette supports a Crosspatch Interface on a dedicated RJ45 connector on the rear panel. The Crosspatch allows connecting two Consolettes such that each will rebroadcast the audio received on the other, to allow cross-system communications. This is especially useful when a user has two systems in two different bands that need to communicate. Consolette Crosspatch operation is not recommended between two repeaters with hangtime enabled, an infinite cycling loop may occur.

4.19.1 Connection

The Consolette comes equipped with the Crosspatch functionality. To operate the feature, first connect a cable between two Consolettes via the dedicated RJ45 Crosspatch connector on the rear panel. Cables are not provided by Motorola. Refer to the manual for the cabling diagram.

The Crosspatch feature can be enabled in the Consolette codeplug via the Configuration App. To disable the Crosspatch functionality, disconnect the cable or set the feature to disabled in the codeplug. Additionally, a softmenu on the auxiliary display or one of the 3 programmable buttons on the front panel can be assigned to the Crosspatch feature allowing a user to toggle the feature on or off without having to remove the cable or modify the codeplug.

4.20 APCO Interface

The Consolette supports an interface providing a set of signals that allow customers flexibility with connecting within their system. This interface is referred to as the APCO Interface and the signals are available on the DB25 connection on the rear of the Consolette. Signals include:

Function	Pin Abbreviation	Definition
Transmit Audio	A(tx)	This is an unbalanced low level transmit audio input relative to ground. The input sensitivity is 300mVrms nominal for rated transmit analog deviation.
Receive Audio	A(rx)	This is an unbalanced receive audio output relative to ground. The output is 300mVrms nominal for rated receive analog deviation. This output is muted when there is not valid audio present.
Push-to-Talk	PTT	This is a logic input to cause the radio to transmit. The radio will transmit when this input is pulled to less than 0.8VDC to ground.
Qualified Audio Presence	A(p)	This signal is the output of an onboard relay(CHAN_ACT_RELAY_OUT). Its level is what is applied to the relay input(CHAN_ACT_RELAY_IN). The normally open relay is activated/closed when there is valid receive audio present. Note: This output is not a simple carrier detect output. It cannot be used as a "Channel Busy" indication.
Monitor	Monitor	This is a logic input to cause the Consolette to toggle the HUB state of the radio. This input is combined with all other active sources of Monitor and HUB within the Consolette.

Figure 4-9 Consolette Signals

One application of using the APCO interface, is the support of external MDC encoders/decoders.

- MDC Encoders – Consolettes can be connected to an external MDC encoder. Encoders are typically used to generate tones that are provided to the Consolette via the audio connection for transmit over the air. An associated Push-to-Talk signal is also provided to key up the Consolette.
- MDC Decoders – Consolettes can be connected to an external MDC decoder. Tones are received over the air by the Consolette and provided on the receive audio path on its rear panel.

NOTE: The auxiliary (APCO) PTT input is mutually exclusive with the Crosspatch CP_PTT. As a result, when Crosspatch is enabled, the APCO PTT is disabled and A(tx) is no longer routed.

4.21 Over-the-air Alert Tones Operation (L999_ Required)

Over-the-air alert tones allow the Consolette operator to advise a fielded subscriber of a critical communication. The Consolette supports this functionality from its front panel. There are three predefined alert tones that can be assigned to either the softmenus underneath the auxiliary display or to the dedicated programmable buttons. The predefined alert tones are:

- Alert 1 sends a 1 kilohertz tone
- Alert 2 sends a pulsed 1500 hertz tone alternating with an 800 hertz tone
- Alert 3 sends a pulsed 1500 hertz tone only

The alert tone is transmitted by the Consolette when the operator presses and holds the alert softkey (or programmed button). The alert tone will continue to transmit for as long as the button is pressed. After the button is released, the Consolette will remain keyed for a programmable period of time (hangtime). The alert tone will be audible on the local speaker. When the operator hears the alert tone stop, the operator will be able to resume normal Consolette operation (ex. key the unit from any supported PTT source).

4.22 Battery (AC Power Fail) Alert Tone Operation

The Consolette can detect when it is operating on a DC input and as a result can generate an alert tone to its local speaker, to a remote user via the wireline, and over-the-air if the Consolette is currently transmitting. This is useful for when remote notification of an AC power failure at the Consolette site is needed. This feature can be enabled in the Consolette codeplug.

This alert tone is predefined and is a 1200 Hz tone transmitted for a duration of 125mS, repeated every 10 seconds. The alert is automatically cleared when AC power is restored.

4.23 Revert to Low RF Power Operation

The Consolette can detect when it is operating on a DC input and as a result can automatically revert to using the low power setting as defined in the radio CPS on any future transmissions. This will help extend the life of the backup battery in cases of AC power failure. Note that when AC is restored, the Consolette will automatically revert back to the power settings defined in the APX CPS for that selected channel. This Revert to Low RF Power Operation can be enabled/disabled in the Consolette codeplug.

4.24 Recorder Operation

The Consolette supports an RJ45 style connector on its rear panel for connection to an external recorder.

The recorder output from the Consolette can be configured as follows:

- Receive audio including tones (ex. Keyfail and Trunking)
- Receive audio including tones plus transmit audio
- Disabled

The audio to the recorder (REC_AUDIO) is an unbalanced low impedance signal at a fixed level of 300mVrms. A logical output (REC_ACTIVITY) is provided to indicate when activity is on the recorder output audio pin. When there is activity on the recorder output audio pin, it will be pulled to less than 0.8VDC.

4.25 External PA Operation

The Consolette supports a connection to an external Public Address amplifier via the DB25 connector on the rear panel.

This audio output (EXT_PA_AUD) from the Consolette can be configured as follows:

- Receive audio without tones (ex. Keyfail and Trunking)
- Receive audio without tones plus transmit audio
- Receive audio including tones plus transmit audio
- Disabled

The audio for use with the external Public Address amplifier (EXT_PA_AUDIO) is an unbalanced low impedance signal at a fixed level of 300mVrms. A logical output (EXT_PA_ACTIVITY) is provided to indicate when activity is on this output audio pin. When there is activity on the output audio pin, it will be pulled to less than 0.8VDC.

4.25.1 Firehouse Day/Night switch

The Consolette supports a feature called Auxiliary Control. This is where a button press on the front panel of the Consolette can control the activation of a general purpose output on the rear of the unit. The general purpose output can be connected to an external relay that could be used to mute/unmute an external PA system. A typical use case is in a firehouse where the PA system needs to be turned off in the evening and then re-enabled during the day.

4.26 VIP Operation

The Consolette supports 3 general purpose outputs and 3 general purpose inputs, also referred to as VIP Outs and VIP Ins. These I/O are available on the rear of the Consolette on a 14 pin terminal connector. A mating adaptor is provided with each Consolette. These I/O can function when a control head is present and also when the control head is not present on the Consolette.

4.26.1 VIP Inputs

The general purpose inputs are active low. A signal of 0.8VDC or lower will activate the input. These signals are pulled high to 5VDC internal to the Consolette. VIP input functionality can be assigned to a radio function and configured using APX CPS. When active, they are pulled to ground.

4.26.2 VIP Outputs

The VIP outputs are open drain N-channel FETs which are driven low by logic within the Consolette when active. The VIP outputs can sink 150mA of current and are primarily used to control external relays. These relays should be connected between the respective VIP output pin and SWB+. There are three SWB+ pins on the 14 pin terminal connector dedicated for use with the three VIP outputs. VIP output functionality can be assigned to a radio function and configured using APX 7500 CPS.

Functionality is programmable by the user. Popular configurations for Consolette users include:

- **Emergency Alarm Receive Indicator** – The Consolette can be set up via APX CPS to activate a VIP output in the event that the Consolette receives an Emergency Alarm.
 - **Auxiliary Control Indication** – The Consolette can be configured such that a button press will activate a VIP output. The buttons that can be programmed to support the Auxiliary Control functionality are the O5 control head programmable buttons and the 3 function buttons on the front of the Consolette. Additionally, the Auxiliary Control functionality can be assigned to the softmenus on the auxiliary display. These softkeys can be programmed with text to help identify what the output is used for (ex. DOOR, ALRM).
 - **Trunking System Status Indication** – The Consolette can be configured via APX 7500 CPS to activate its VIP outputs in the event that the Consolette enters the following Trunking system states: Out of Range, Site Trunking or Failsoft. Each indication can be assigned a specific VIP Output. This can be used to provide real-time feedback to the radio dispatchers for when the trunked site exits Wide Area operation. Typically the VIP outputs are tied to the Aux I/O interface of the console, an external relay or compatible accessory.
 - **Horn and Lights** – The Consolette can be configured via APX 7500 CPS to activate its VIP outputs based on the Radio's External Horn and Lights Alarm feature. The External Alarm is activated by an incoming Call Alert / Page, Selective / Private Call, Phone Call, or Message. Once activated, the External Alarm can trigger externally attached hardware such as flashing lights, a PA, or a horn.
-

4.27 External Speaker

The Consolette supports connection on its rear panel to the 8-ohm mobile speaker. The mobile speaker cable must be modified in order to connect to the 14-pin terminal connector, J103 pins 1 (EXT_SPKR+) and 2 (EXT_SPKR-).

NOTE: EXT_SPKR- and EXT_SPKR+ should never be grounded. If they are grounded, this will damage the radio.

This speaker provides receive audio and alert tones but not transmit audio. The speaker may be configured using APX CPS to either maintain a fixed volume, or to track the O5 volume knob. Additionally, there is an external speaker active output which indicates when the external speaker is unmuted. EXT_SPKR_ACTIVITY (driven low when valid audio activity is present on the secondary speaker) is located on the DB25 Accessories Connector J104 pin 23.

The normal operation of the external speaker can be configured to be overridden by:

- connection of a Headset to the Consolette when tracking local speaker.
- activation of the MUTE_IN signal to the rear of the Consolette.
- activation of the Speaker Mute Button from the front panel when tracking local speaker.

4.28 Audio Jack

The Consolette supports a dedicated connection for use with a powered speaker or a computer soundcard input. This output is a fixed level “line out” audio output at a nominal 300mVrms. This audio includes receive audio and alert tones (no transmit audio). When there is no valid audio, this audio path is muted.

NOTE: Refer to the external equipment’s manual to ensure its maximum input audio specification is not exceeded.

The connection is a dedicated 3.5 mm audio jack provided at the rear panel of the Consolette. A three-conductor 3.5 mm TRS (tip, ring, sleeve) connector or stereo plug should be used in conjunction with this jack. The Consolette does not provide a true stereo output at this jack; however, the same receive audio and alert tones are supplied to both the right and left speaker connections.

4.29 Crossmute Operation

The Consolette supports a Crossmute Interface on the DB25 connector on the rear panel. Crossmute allows an automated method of muting a Consolette while a second Consolette in close proximity is transmitting. This prevents noise due to RF desense from being heard on the speakers of the nearby, non-transmitting units.

4.29.1 Connection and Operation

The Consolette comes equipped with the Crossmute functionality. To operate the feature, first connect a cable between two Consolettes via the DB25 connector on each rear panel. Cables are not provided by Motorola. Refer to the manual for the cabling diagram.

When the Crossmute cable is connected, the Crossmute feature will function automatically. To disable the Crossmute functionality, disconnect the cable.

The TX_ACTIVITY output of one Consolette can be connected to the MUTE_IN input of another Consolette and vice versa. The Crossmute hardware is designed such that the TX_ACTIVITY output from one Consolette is the correct level to drive the MUTE_IN input on another. When Crossmute is enabled on the Consolette and it is transmitting, the Consolette will assert its TX_ACTIVITY output pin. This output will then activate the MUTE_IN input of the connected Consolette causing the Consolette to mute its local speaker.

4.30 Emergency

The Consolette supports a logic input that when asserted can trigger an over-the-air Emergency Alarm as if the user pressed the Emergency button on the front of the O5 control head.

This interface can be used with an Emergency Footswitch. The user would have to modify the accessory to attach to the DB25 connector on the rear of the Consolette. To activate this input, the EMERGENCY signal must be pulled to a logic low (less than 0.8VDC).

Notes

SECTION 5 PROGRAMMING APPLICATIONS

5.1 Programming the Consolelette

Programming and setup of the Consolelette is required prior to use. Refer to the APX 7500 Consolelette detailed service manual for more details regarding the configuration of the Consolelette using a web browser. Initial programming involves two programming methods:

- Setup of the transceiver codeplug using APX CPS.
- Setup of the internal Consolelette controller card using a web browser to access the built-in Configuration App.

NOTE: All programming can be accomplished without removal of the Consolelette lid.

5.1.1 PC and Network Requirements

5.1.1.1 PC requirements for APX CPS

- Processor 2 GHz dual core or higher Pentium grade processor
- Memory 2 GB RAM
- Aero capable graphics card with 128 MB graphics memory
- 250 MB minimum free hard disk space
- USB Port or parallel port for iButton dongle
- USB Port for radio communication
- CD-ROM for software installation
- Operating Systems: Windows XP Home or Professional (SP 2 or higher)
Vista Home Premium 32-bit (SP 1 or higher)
Vista Business 32-bit (SP 1 or higher)

5.1.1.2 PC requirements for On Board Configuration Application

Consolelette configuration is performed using a standard web browser interface, either by way of the Ethernet network or the USB port. The Consolelette configuration pages have been tested with Internet Explorer 6, 7, 8 and with Firefox 3.x, and should be compatible with any comparable browser. Consolelette configuration requires the browser to have Javascript enabled.

5.1.1.3 Network security requirements for On Board Configuration Application

Consolelette configuration is protected by a basic username/password. The Consolelette does not support secure browsing (e.g. HTTPS or SSL). If a higher level of security is required by the customer, the Consolelette should be placed on a secured network. Physical access to the Ethernet and USB connectors should be restricted to approved personnel.

5.1.1.4 Network Performance for On Board Configuration Application

No specific level of network performance is required to support Consolette configuration. The Consolette defaults to an unroutable address (169.254.132.2) on the Ethernet interface and to an unroutable address (192.168.144.1) on the USB interface. These addresses can be set as required during the initial unit configuration.

5.1.2 APX CPS Codeplug Programming

The APX CPS application is used for set up of the transceiver features including the transmit and receive frequencies, the zones and channels, the conventional and trunking personalities, and the O5 display. This requires the GCAI USB cable (HKN6184_) for connection between the PC and either the GCAI connector on the O5 control head or on the auxiliary GCAI connector on the front panel of the Consolette.

For details on the operation of the transceiver and its settings, refer to the APX 7500 Detailed Service Manual, 6875963M01, and the O5 Control Head User's Guide, 6875947M01.

Additionally, the APX CPS application is used to Flash upgrade the O5 control head, the transceiver, and the Consolette controller card firmware if needed. This requires the GCAI USB cable (HKN6184_) for connection between the PC and either the GCAI connector on the O5 control head or on the auxiliary GCAI connector on the front panel of the Consolette.

5.1.3 Controller Card Configuration using a Web Browser

The Consolette controller card is configured using a standard web browser running on a computer. Additional programming software is not required as the application resides within the Consolette. Supported connection methods include USB and Ethernet.

NOTE: Recommended web browsers include Internet Explorer and Firefox.

5.1.3.1 Establishing a connection to the Consolette

5.1.3.1.1 Connection by USB

The Consolette may be locally configured by USB. The Consolette supports a USB/RNDIS networking interface. Connect the Consolette to the PC using the USB device port (the square port) on the back panel of the Consolette.

NOTE: The Consolette default address is 192.168.144.1. For the PC to recognize the Consolette, it is necessary to install the setup information file MotorolaRadioRNDIS.inf on the PC. This is the same file used by other Motorola radios for USB connectivity (e.g. for packet data applications) and may already be present on the PC as it is a file normally installed by the APX Family CPS; however, if Windows cannot locate a driver for the Consolette even though this file is already installed, a newer version of the file may be required.

5.1.3.1.2 Connection by Ethernet

The Consolette may be configured remotely over a LAN. The Consolette supports a standard 10/100 Ethernet network interface. Connect the Consolette to the network using a CAT-5 cable from the LAN port on the rear panel of the Consolette.

NOTE: The Consolette default address is the non-routable address 169.254.132.2. The address must be configured appropriately for use on a LAN. The Consolette LAN port supports automatic cable detection and crossover. For initial configuration a computer may be directly connected to the Consolette LAN port with a CAT-5 cable.

Notes

SECTION 6 ORDERING GUIDE

6.1 Ordering steps

Refer to the following steps in this section for information on ordering the APX 7500 Console.

Optional Features can be ordered depending on the required functionality.

6.2 Ordering Options

6.2.1 Required Options

6.2.1.1 Step 1: APX 7500 Console Main Model

Required Main Model (Must Select One)	
	Mid Power Models
(Must Select One)	a. L30URS9PW1_N Single Band 7/800 MP b. L30KSS9PW1_N Single Band VHF MP c. L30QSS9PW1_N Single Band UHF R1 MP d. L30SSS9PW1_N Single Band UHF R2 MP e. L30TSS9PW1_N Dual Band MP
Dual Band Options (Required on Dual Band Model only)	
PRIMARY BAND OPTIONS (Must select ONE if choosing Dual Band Model)	a. GA00244 7/800MHZ Primary Band b. GA00306 VHF MP Primary Band c. GA00341 UHF R1 MP Primary Band d. GA00345 UHF R2 MP Primary Band
SECONDARY BAND OPTIONS (Must select ONE if choosing Dual Band Model)	a. GA00225 7/800MHZ Secondary Band b. GA00308 VHF MP Secondary Band c. GA00343 UHF R1 MP Secondary Band d. GA00346 UHF R2 MP Secondary Band
ENABLE DUAL BAND OPTION (Must select if enabling secondary band)	a. GA00579 Enable Dual Band Option

6.2.1.2 Step 2: Operation Mode

Required Options (Steps 1–9)	
(Must Select One)	a. G241 Analog b. G806 Digital CAI Operation

6.2.1.3 Step 3: System Enhancement Software

System Enhancement Software (Must Select)	
(Must Select One)	a. G48 Conventional b. G50 SMARTNET* c. G51 SMARTZONE*

* When G50 or G51 is chosen then you must also select one of the following: QA01648 Advance System Key Hardware or QA01749 Advance System Key Software.

6.2.1.4 Step 3B: System Enhancement Software

Optional System Enhancement Software	
(Optional)	a. G173 SMARTZONE OMNILINK b. G361 APCO P25 Trunking c. GA00580 TDMA Operation d. GA01767 Add: Radio Authentication (requires option G361 to be ordered)

6.2.1.5 Step 4: Front Panel Configuration

Required Options (Steps 1–9)	
(Must Select One)	a. L999AA FULL FP b. L998AA LIMITED FP

6.2.1.6 Step 5: Microphones

Required Option (if L999_ is ordered)	
(Must Select One)	a. G90 NO MICROPHONE NEEDED b. W382 CONTROL STATION DESK GCAI MIC

6.2.1.7 Step 6: Power Cords

Required Options	
(Must Select One)	a. CA01598 Add: AC Line Cord US b. CA01600 Add: AC Line Cord BS1363 Plug UK c. CA01602 Add: AC Line Cord AS3112 Plug Australia d. CA01608 Add: AC Line Cord Brazil e. GA00200 Add: Argentina Power Cord

6.2.2 Optional Features

Optional Features	
System Enhancement Options (Optional)	a. G387 MULTICAST VOTING SCAN b. G996 OVER THE AIR PROVISIONING c. W947 PACKET DATA INTERFACE d. GA00469AA EXTENDED DISPATCH OPERATION
Hardware Encryption Algorithms (Optional)	a. W969 MULTIPLE KEY ENCRYPTION (Hardware)* b. GA00236 3 DAY KEY RETENTION APX c. G298 P25 & MDC OTAR d. G843 AES ENCRYPTION e. G851 AES/DES-XL/DES-OFB f. G625 DES/DES-XL/DES-OFB g. W797 DVP-XL
DC Cord (Optional)	a. CA01942 DC Cord
Service Options (Optional)	a. G77 1YR RSA b. G78 2YR RSA c. GA00232 3YR RSA
Amplifier (Optional)	a. W12 RF PREAMP

* W969 - Required for ACIM configurations where Secure Key Select and Secure Key In is utilized.

6.2.3 Aftermarket Accessories

External Speaker (Optional)	HSN4018 AUXILIARY SPKR 7.5 WATT
Rack Mount Tray (Optional)	HKN6233_
Spare 14-pin Adaptor (Optional)	28009234001
Spare Coin Cell Battery (Optional)	6071032M01
Packing Kit (Required for field return)	HBN5097_
APX CPS	RVN5224
Headset Jack Box (Optional)	FHN7470_
Headset Base w/PTT (Optional)	CDN6281

6.3 Ordering Examples

6.3.1 Example 1

Ordering a Mid Power Dual Band APCO P25 Trunking Equipped Console

1	L30TSS9PW1_N	ASTRO APX 7500 MULTI BAND Console	Comments
1A	GA00244	700/800 mHZ Primary Band	Choose Primary band (operational band)
1B	GA00308	VHF MP Secondary Band	Choose Secondary Band (additional cost to enable)
1C	GA00579	Enable Dual Band Operation	Select this option to enable secondary band (primary band is automatically enabled)
1D	G806	Software ASTRO Digital CAI Operation	Select Operation Mode
1E	G51	SMARTZONE Operation	Select System Enhancement Software
1F	G361	ASTRO Project 25 Trunking Software	Select an Optional System Enhancement Software
1G	L999_	Full FP w/O5/Keypad/Clock/ VU	Select Control Head Hardware
1H	QA01749	SW Key Supplemental Data	Select the Auxiliary Programming Port Style
1I	W382	Control Station Desk GCAI MIC	Select Microphone
1J	CA01598	AC Line Cord US	Select Power Cord

Order the APX 7500 Console Series as the main line item.

- A Primary Band MUST be ordered with each hardware model.
- A Secondary Band MUST be ordered with each hardware model.
- If you want the secondary band enabled, you MUST select the "enable dual band operation" option.
- You must choose an Operation Mode.
- You must choose a System Enhancement Software package.
- A front panel configuration (with control head or without control head) must be selected.
- When L999_ is ordered then you must select a microphone selection. G90, no microphone needed, is a valid microphone selection.
- When ordering G50 or G51 then you must also select QA01749 or QA01648.
- You must choose a power cord.

NOTE: APX 7500 Console ships with 12 month standard warranty.

6.3.2 Example 2

Ordering a Mid Power Single Band APCO P25 Trunking Equipped Console.

1	L30KSS9PW1_N	ASTRO APX 7500 VHF SINGLE BAND Console
1A	G806	ENH: ASTRO DIGITAL CAI OP APX
1B	G51	ENH: SMARTZONE OPERATION APX
1C	G361	ASTRO PROJECT 25 TRUNKING SOFTWARE
1D	L998_	ADD: LIMITED FRONT PANEL W/CLOCK/VU
1E	QA01749	ADD: ADVANCED SYSTEM KEY - SOFTWARE KEY
1F	CA01598	ADD: AC LINE CORD US

Order the APX 7500 Console Series as the main line item.

- You must choose an Operation Mode.
- You must choose a System Enhancement Software package.
- When ordering G50 or G51 A SOFTWARE or HARDWARE KEY is REQUIRED to be purchased. HARDWARE KEY will still REQUIRE a DVN4046 to be purchased.
- A front panel configuration (with control head or without control head) must be selected.
- If L999_ is ordered, either Add Microphone or Delete Microphone must be selected. If L998_ is ordered, a microphone option is not available.
- You must choose a power cord.

NOTE: APX 7500 Console ships with 12 month standard warranty.

Notes

SECTION 7 RECOMMENDED CABLING

The APX 7500 Consolette has several ports and supports many different style cables. The chart in this section describes the functionality required along with the corresponding Consolette port locations and the supported cable kits.

Description	Connector Location	Cable
CPS Programming (USB) the transceiver	GCAI on O5 Control Head or AUX GCAI on Front Panel	HKN6184_
Flash Programming (USB) both the transceiver and the Consolette controller card.	GCAI on O5 Control Head or AUX GCAI on Front Panel	HKN6184_
Radio data applications (USB)	GCAI on O5 Control Head or AUX GCAI on Front Panel	HKN6184_
Radio data applications (RS232)	GCAI on O5 Control Head or AUX GCAI on Front Panel	HKN6183_
Tactical OTAR (RS232)	GCAI on O5 Control Head or AUX GCAI on Front Panel	HKN6183_
Consolette Configuration (Ethernet)	Ethernet/LAN connector on rear of Consolette	OTS CAT5 Ethernet cabling
Consolette Configuration (USB)	USB-B connector on rear of Consolette	OTS USB-A to USB-B cable
Keyloading (all keys)	Aux GCAI on front of Consolette	TKN8531_ HKN6182_
TRC	RJ45 wireline on rear panel	Customer provided cabling
ACIM	RJ45 wireline and RJ45 ACIM on rear panel	Customer provided cabling
E&M	RJ45 wireline and DB25 on rear panel	Customer provided cabling
MCD 5000	RJ45 LAN on rear panel	OTS CAT5 Ethernet cabling

Notes

SECTION 8 SPECIFICATIONS

8.1 APX 7500 Project 25 Multi-Band Console

8.1.1 Transmitter Specification

	700 MHz	800 MHz	VHF	UHF R1	UHF R2
Frequency Range/ Bandplits	764-776 MHz 794-806 MHz	806-824 MHz 851-870 MHz	136-174 MHz	380-470 MHz	450-520 MHz
Channel Spacing	25/12.5 kHz	25/20/12.5 kHz	30/25/12.5 kHz	25/12.5 kHz	25/12.5 kHz
Maximum Frequency Separation	Full Bandsplit	Full Bandsplit	Full Bandsplit	Full Bandsplit	Full Bandsplit
Rated RF Output Power Adj*	10-30 Watts	10-35 Watts	10-50 Watts	10-40 Watts	10-45 Watts (450-485 MHz) 10-40 Watts (485-512 MHz) 10-25 Watts (512-520 MHz)
Frequency Stability* (-30°C to +60°C; +25°C Ref.)	±0.00015 %	±0.00015 %	±0.0002 %	±0.0002 %	±0.0002 %
Modulation Limiting*	±5 kHz/±2.5 kHz	±5 kHz/±4 kHz (NPSPEC) /±2.5 kHz	±5 kHz/±2.5 kHz	±5 kHz/±2.5 kHz	±5 kHz/±2.5 kHz
Modulation Fidelity (C4FM) 12.5kHz Digital Channel	±2.8 kHz	±2.8 kHz	±2.8 kHz	±2.8 kHz	±2.8 kHz
Emissions*	Conducted+ Radiated+ -70/-85 dBc -20/-40 dBm	Conducted+ Radiated+ -70 dBc -20 dBm	Conducted+ Radiated+ -85 dBc -20 dBm	Conducted+ Radiated+ -85 dBc -20 dBm	Conducted+ Radiated+ -85 dBc -20 dBm
Audio Response*	+1, -3 dB (EIA)	+1, -3 dB (EIA)	+1, -3 dB (EIA)	+1, -3 dB (EIA)	+1, -3 dB (EIA)
FM Hum & Noise (25 & 20 KHz/12.5 KHz)	40/34 dB	40/34 dB	50/40 dB	45/40 dB	45/40 dB
Audio Distortion*	2%	2%	2%	2%	2%

8.1.2 Receiver Specification

	700 MHz	800 MHz	VHF	UHF R1	UHF R2
Frequency Range/Bandsplits	700 MHz 764-776	800 MHz 851-870 MHz	VHF 136-174 MHz	UHF R1 380-470 MHz	UHF R2 450-520 MHz
Channel Spacing	25/12.5 kHz	25/20/12.5 kHz	30/25/12.5 kHz	25/12.5 kHz	25/12.5 kHz
Maximum Frequency Separation	Full Bandsplit	Full Bandsplit	Full Bandsplit	Full Bandsplit	Full Bandsplit
Audio Output Power at 3% distortion*	2.5W++	2.5W++	2.5W++	2.5W++	2.5W++
Frequency Stability* (-30°C to +60°C; +25°C Ref.)	±0.00015 %	±0.00015 %	±0.0002 %	±0.0002 %	±0.0002 %
Analog Sensitivity* 12 dB SINAD	0.25 µV	0.25 µV	Pre-Amp Standard 0.2 µV 0.3 µV	Pre-Amp Standard 0.2 µV 0.3 µV	Pre-Amp Standard 0.2 µV 0.3 µV
Digital Sensitivity 1% BER	0.3 µV	0.3 µV	0.25 µV 0.25 µV	0.25 µV 0.4 µV	0.25 µV 0.4 µV
5% BER	0.25 µV	0.25 µV	0.2 µV 0.2 µV	0.2 µV 0.3 µV	0.2 µV 0.3 µV
Intermodulation	80 dB	80 dB	80 dB 85 dB	80 dB 85 dB	80 dB 85 dB
Spurious Rejection	90 dB	90 dB	90 dB	90 dB	90 dB
Audio Distortion at rated*	3.00%	3.00%	3.00%	3.00%	3.00%
Selectivity* 25 kHz	80 dB	80 dB	-	82 dB	82 dB
12.5 kHz	65 dB	65 dB	70 dB	70 dB	70 dB
30 kHz	-	-	90 dB	-	-

8.1.3 Power and Battery Specification

Minimum RF Power Output	10-35 Watts (764-870 MHz), 10-50 Watts (136-174 MHz), 10-40 Watts (380-470 MHz), 10-45 Watts (450-485 MHz), 10-40 Watts (485-512 MHz), 10-25 Watts (512-520 MHz)
RF Connector	N-type coaxial
AC Operation	110 to 220VAC 50-60Hz
AC Current	110VAC: 0.85A (Idle/Rx), 1.7A (Tx) 220VAC: 0.42A (Idle/Rx), 0.85A (Tx)
AC Surge Spec	EN6100-4-5 Level 5
DC Operation	13.8VDC ±20% Negative Ground
Standby at 13.8V	1.25A (764-870 MHz), 1.25A (136-174 MHz), 1.25A (380-470 MHz), 1.25A (450-520 MHz)
Receive Current at Rated Audio at 13.8V	1.5A (764-870 MHz), 1.5A (136-174 MHz), 1.5A (380-470 MHz), 1.5A (450-520 MHz)
Transmit Current (A) at Rated Power	136-174 MHz (10-50 Watts) 13A (50W) 8A (15W) 380-470 MHz (10-40 Watts) 11A (40W) 8A (15W) 450-520 MHz (10-45 Watts) 11A (45W) 8A (15W) 764-870 MHz (10-35 Watts) 12A (35W) 8A (15W)

8.1.4 Regulatory Certifications

FCC Part 90
FCC Part 15, Class B
FCC Part 68/TIA968 -A
UL and CSA approval (UL60950)

8.1.5 Environmental Specification

Operating Temperature	-30°C /+60°C
Storage Temperature	-40°C /+85°C
Humidity	95% relative humidity
ESD	IEC 61000-4-2
Duty Cycle	EIA/TIA Intermittent Duty Cycle

8.1.6 FCC Certification ID

FCC ID	Model/ IC Model Number	IC Designation	Band and Power Level	RF Band Combination
AZ492FT3824	L30KSS9PW1AN	109U-92FT3824	10-50 Watts (136-174 MHz)	VHF
AZ492FT4894	L30QSS9PW1AN	109U-92FT4894	10-40 Watts (380-470 MHz)	U1
AZ492FT4895	L30TSS9PW1AN L_MHUT1008A	109U-92FT4895	10-50 Watts (136-174 MHz) and 10-40Watts (380-470 MHz)	VHF/U1
AZ492FT4896	L30SSS9PW1AN	109U-92FT4896	10-45 Watts (450-520 MHz)	U2
AZ492FT4904	L30TSS9PW1AN		10-40 Watts (380-470 MHz) and 10-45 Watts (450-520 MHz)	U1/U2
AZ492FT5858	L30URS9PW1AN	109U-92FT5858	10-35 Watt (764-870 MHz)	7/800 MHz
AZ492FT7037	L30TSS9PW1AN	109U-92FT7037	10-50 Watts (136-174 MHz) and 10-35 Watt (764-870 MHz)	7/800/VHF
AZ492FT7043	L30TSS9PW1AN L_MHUS1008A	109U-92FT7043	10-40 Watts (380-470 MHz) and 10-35 Watts (764-870 MHz)	7/800/U1
AZ492FT7044	L30TSS9PW1AN L_MHUS1006A	109U-92FT7044	10-45 Watts (450-520 MHz) and 10-35 Watts (764-870 MHz)	7/800/U2
AZ492FT7047	L30TSS9PW1AN L_MHUT1010A	109U-92FT7047	10-50 Watts (136-174 MHz) and 10-45 Watts (450-520 MHz)	VHF/U2

8.1.7 General

Limited Front Panel Configuration (Dimension W x D X H)	16" x 18.1" x 4.2" (406 x 457 x 107mm)
Full Feature Front Panel Configuration (Dimension W x D x H)	16" x 18.75" x 4.2" (406 x 476 x 107mm)
Limited Front Panel Configuration (Weight)	18.5 lbs (8.4 kg)
Full Feature Front Panel Configuration (Weight)	19.5 lbs (8.9 kg)

8.1.8 Others

Wireline Specification	
Wireline Configuration	2-wire or 4-wire capable; 600ohm or bridging impedances.
Guard Tones	2175Hz(Default), 2100Hz, 2300Hz and 2325Hz.
Function Tones	450Hz - 2050Hz in 100Hz increments.
Tone Tolerance	±10Hz
Range of detection	-30dBm to +13dBm
Wireline Connector	RJ45
Wireline Surge	TIA-968-A, Section 4.2.2 Type A Surge Metallic: A peak voltage of at least 800V and a peak short circuit current of at least 100A. Type A Surge Longitudinal: A peak voltage of at least 1500V and a peak short circuit current of at least 200A.

ACIM Specification	
ACIM Signal Levels	RS232; 2-wire operation only
ACIM Connector Type	RJ45

USB Specifications	
USB Connector Type	Type A (Host), Type B (Device)
Data Rate	USB 1.1 Full Speed Compliant
Allowable Accessories	See Target Peripheral List

E&M Specifications	
Input	Qty 1, for PTT, active LOW
Input Rating	5.5V, 12mA MAX
Relay Output	Qty 1, follows channel activity.
Relay Output Type	Form A, SPST, normally open solid state relay, 350V, 120 mA MAX.

E&M Connector	DB25
---------------	------

LAN Specifications

Bandwidth	10/100-Base-T
-----------	---------------

VIP Specifications

Input Rating	5.5V, 12mA MAX
--------------	----------------

Output Rating	Open Drain N-channel FET, 28V, 150mA MAX
---------------	--

VIP Connector Type	14-pin terminal connector, adapter connector shipped with unit.
--------------------	---

Crosspatch Specifications

Crosspatch Connector Type	RJ45
---------------------------	------

Recorder Specifications

Recorder Connector Type	RJ45
-------------------------	------

Recorder Configurations	Off, Receive, Receive and Transmit
-------------------------	------------------------------------

Recorder Activity Output	Open Drain N-channel FET, 28V, 150mA MAX
--------------------------	--

Specifications subject to change without notice.

Notes

SECTION 9 COMMERCIAL WARRANTY

9.1 Limited Warranty

9.1.1 MOTOROLA COMMUNICATION PRODUCTS

9.1.1.1 What This Warranty Covers And For How Long

MOTOROLA SOLUTIONS INC. ("MOTOROLA") warrants the MOTOROLA manufactured Communication Products listed below ("Product") against defects in material and workmanship under normal use and service for a period of time from the date of purchase as scheduled below:

ASTRO APX 7500 Console Radio	One (1) Year
Product Accessories	One (1) Year

Motorola, at its option, will at no charge either repair the Product (with new or reconditioned parts), replace it (with a new or reconditioned Product), or refund the purchase price of the Product during the warranty period provided it is returned in accordance with the terms of this warranty. Replaced parts or boards are warranted for the balance of the original applicable warranty period. All replaced parts of Product shall become the property of MOTOROLA.

This express limited warranty is extended by MOTOROLA to the original end user purchaser only and is not assignable or transferable to any other party. This is the complete warranty for the Product manufactured by MOTOROLA. MOTOROLA assumes no obligations or liability for additions or modifications to this warranty unless made in writing and signed by an officer of MOTOROLA. Unless made in a separate agreement between MOTOROLA and the original end user purchaser, MOTOROLA does not warrant the installation, maintenance or service of the Product.

MOTOROLA cannot be responsible in any way for any ancillary equipment not furnished by MOTOROLA which is attached to or used in connection with the Product, or for operation of the Product with any ancillary equipment, and all such equipment is expressly excluded from this warranty. Because each system which may use the Product is unique, MOTOROLA disclaims liability for range, coverage, or operation of the system as a whole under this warranty.

9.1.1.1.1 General Provisions

This warranty sets forth the full extent of MOTOROLA'S responsibilities regarding the Product. Repair, replacement or refund of the purchase price, at MOTOROLA's option, is the exclusive remedy. THIS WARRANTY IS GIVEN IN LIEU OF ALL OTHER EXPRESS WARRANTIES. IMPLIED WARRANTIES, INCLUDING WITHOUT LIMITATION, IMPLIED WARRANTIES OF MERCHANTABILITY AND FITNESS FOR A PARTICULAR PURPOSE, ARE LIMITED TO THE DURATION OF THIS LIMITED WARRANTY. IN NO EVENT SHALL MOTOROLA BE LIABLE FOR DAMAGES IN EXCESS OF THE PURCHASE PRICE OF THE PRODUCT, FOR ANY LOSS OF USE, LOSS OF TIME, INCONVENIENCE, COMMERCIAL LOSS, LOST PROFITS OR SAVINGS OR OTHER INCIDENTAL, SPECIAL OR CONSEQUENTIAL DAMAGES ARISING OUT OF THE USE OR INABILITY TO USE SUCH PRODUCT, TO THE FULL EXTENT SUCH MAY BE DISCLAIMED BY LAW.

9.1.1.1.2 State Law Rights

SOME STATES DO NOT ALLOW THE EXCLUSION OR LIMITATION OF INCIDENTAL OR CONSEQUENTIAL DAMAGES OR LIMITATION ON HOW LONG AN IMPLIED WARRANTY LASTS, SO THE ABOVE LIMITATION OR EXCLUSIONS MAY NOT APPLY.

This warranty gives specific legal rights, and there may be other rights which may vary from state to state.

9.1.1.1.3 How To Get Warranty Service

You must provide proof of purchase (bearing the date of purchase and Product item serial number) in order to receive warranty service and, also, deliver or send the Product item, transportation and insurance prepaid, to an authorized warranty service location. Warranty service will be provided by Motorola through one of its authorized warranty service locations. If you first contact the company which sold you the Product, it can facilitate your obtaining warranty service. You can also call Motorola at 1-888-567-7347 US/Canada.

9.1.1.1.4 What This Warranty Does Not Cover

- a. Defects or damage resulting from use of the Product in other than its normal and customary manner.
 - b. Defects or damage from misuse, accident, water, or neglect.
 - c. Defects or damage from improper testing, operation, maintenance, installation, alteration, modification, or adjustment.
 - d. Breakage or damage to antennas unless caused directly by defects in material workmanship.
 - e. A Product subjected to unauthorized Product modifications, disassemblies or repairs (including, without limitation, the addition to the Product of non-Motorola supplied equipment) which adversely affect performance of the Product or interfere with Motorola's normal warranty inspection and testing of the Product to verify any warranty claim.
 - f. Product which has had the serial number removed or made illegible.
 - g. Rechargeable batteries if:
 - any of the seals on the battery enclosure of cells are broken or show evidence of tampering.
-

- the damage or defect is caused by charging or using the battery in equipment or service other than the Product for which it is specified.
- h. Freight costs to the repair depot.
- i. A Product which, due to illegal or unauthorized alteration of the software/firmware in the Product, does not function in accordance with MOTOROLA's published specifications or the FCC certification labeling in effect for the Product at the time the Product was initially distributed from MOTOROLA.
- j. Scratches or other cosmetic damage to Product surfaces that does not affect the operation of the Product.
- k. Normal and customary wear and tear.

9.1.1.1.5 Patent And Software Provisions

MOTOROLA will defend, at its own expense, any suit brought against the end user purchaser to the extent that it is based on a claim that the Product or parts infringe a United States patent, and MOTOROLA will pay those costs and damages finally awarded against the end user purchaser in any such suit which are attributable to any such claim, but such defense and payments are conditioned on the following:

- a. that MOTOROLA will be notified promptly in writing by such purchaser of any notice of such claim;
- b. that MOTOROLA will have sole control of the defense of such suit and all negotiations for its settlement or compromise; and
- c. should the Product or parts become, or in MOTOROLA's opinion be likely to become, the subject of a claim of infringement of a United States patent, that such purchaser will permit MOTOROLA, at its option and expense, either to procure for such purchaser the right to continue using the Product or parts or to replace or modify the same so that it becomes noninfringing or to grant such purchaser a credit for the Product or parts as depreciated and accept its return. The depreciation will be an equal amount per year over the lifetime of the Product or parts as established by MOTOROLA.

MOTOROLA will have no liability with respect to any claim of patent infringement which is based upon the combination of the Product or parts furnished hereunder with software, apparatus or devices not furnished by MOTOROLA, nor will MOTOROLA have any liability for the use of ancillary equipment or software not furnished by MOTOROLA which is attached to or used in connection with the Product. The foregoing states the entire liability of MOTOROLA with respect to infringement of patents by the Product or any parts thereof.

Laws in the United States and other countries preserve for MOTOROLA certain exclusive rights for copyrighted MOTOROLA software such as the exclusive rights to reproduce in copies and distribute copies of such Motorola software. MOTOROLA software may be used in only the Product in which the software was originally embodied and such software in such Product may not be replaced, copied, distributed, modified in any way, or used to produce any derivative thereof. No other use including, without limitation, alteration, modification, reproduction, distribution, or reverse engineering of such MOTOROLA software or exercise of rights in such MOTOROLA software is permitted. No license is granted by implication, estoppel or otherwise under MOTOROLA patent rights or copyrights.

9.1.1.1.6 Governing Law

This Warranty is governed by the laws of the State of Illinois, USA.

Notes

SECTION 10 ACRONYMS AND DEFINITIONS

10.1 Terms and Definitions

The following items listed below are the terms and definitions:

Term	Definition
10/100-BASE-T	10/100 Megabit Twisted Pair Ethernet Network
2W	Two-Wire Interface (Transmit and Receive on same copper pair)
4W	Four-Wire Interface (Transmit and Receive on different copper pairs)
ACIM	ASTRO Console Interface Module; a Motorola proprietary digital RS232 interface to the Console via the CCGW
AGC	Automatic Gain Control
ASTRO	Brand name for APCO 25 compliant product
CCGW	Conventional Channel Gateway
Channel	The multiple frequencies/talkgroups that a Consolette station can support
Channel Activity	Another name for the base station's E-Lead. An output from the station indicating it is receiving a qualified signal.
CPS	Customer Programming Software; a PC-based software tool that allows customizing radio functionality, including transmit and receive frequencies.
E&M Keying	Ear and Mouth Keying. See PTT and Channel Activity.
FCC	Federal Communications Commission
FT (Function Tone)	The short tone bursts that follow high level guard tone. These bursts are mapped to functions in the station. For instance, Setting the repeat mode, choosing a frequency, etc. Typically function tone is 40 ms in length. Dual function tone may be needed if encryption is supported.
GCAI	Global Core Accessory Interface; Motorola proprietary accessory port for use with Motorola approved cables; USB and RS232 styles supported
HLGT (High Level Guard Tone)	The initial tone of a TRC sequence begins with High Level Guard Tone. Typically a 120 ms burst of guard tone at an elevated level.
ID	Identification
IP	Internet Protocol
LAN	Local Area Network
LED	Light Emitting Diode
LLGT (Low Level Guard Tone)	If the base station is to remain keyed the last function tone is followed by low level guard tone. As long as low level guard tone is present the station will remain keyed. When voice is routed to the station, it is summed with low-level guard tone in order to keep the station keyed.
MDC1200	Motorola signaling format used on radio transmissions

Term	Definition
NIC	Network Interface Card
OS	Operating System
OTS	Off-the-shelf
PC	Personal Computer
PTT	Push-to-talk; Another name for the base station's M-Lead. An input to the station to cause it to transmit over the air.
RoHS	Restriction of Hazardous Substances, European Union Regulation
RS232	A TIA/EIA standard for serial transmission between computers and peripheral devices, officially known since 1984 as TIA/EIA-232-E.
RTP	Real-time Transport Protocol
RTTE	Radio Equipment and Telecommunications Terminal Equipment
TCP/IP	Transmission Control Protocol / Internet Protocol
TRC	Tone Remote Control
UDP	User Datagram Protocol
USB	Universal Serial Bus
VoIP	Voice over Internet Protocol
VPN	Virtual Private Network
WAN	Wide Area Network
WEEE	Waste Electrical and Electronic Equipment

SECTION 11 FREQUENTLY ASKED QUESTIONS (FAQ)

11.1 Questions and Answers

Question	Answer
Does the APX 7500 Consolette support a VU Meter/Clock?	The APX 7500 Consolette does support a VU Meter and also a Clock display on the auxiliary display on its front panel. Each unit comes equipped with this auxiliary display and as a result, a specific option for the VU Meter and/or Clock is not required. The clock can be set by network time if connected to the network.
Does the APX 7500 Consolette support battery revert operation?	Back by popular demand, the APX 7500 Consolette supports battery revert operation. In the event of AC failure, the APX 7500 Consolette will automatically switch over to use its DC input without service interruption. Once AC is restored, the unit will return to using the AC input. There is no charging capability on this DC input.
Does the APX 7500 Consolette support 100% duty cycle?	No. The APX 7500 Consolette specification is for the Intermittent Duty Cycle as defined by EIA/TIA. This is a 1 minute transmit followed by a 4 minute receive operation.
Is the APX 7500 Consolette offered in a dual band model?	Yes, the APX 7500 Consolette is available as a single band model or as a dual band model. Refer to the ECATs/Price Pages for more details.
What signaling types does the APX 7500 Consolette support?	With the proper ordered options the APX 7500 Consolette can support the following signaling types: Analog Conventional, Analog Conventional with MDC, APCO Conventional, Type II Trunking (both analog and digital talkgroups), APCO P25 Trunking (including the new F2 support).
Does the APX 7500 Consolette support the ACIM interface?	The APX 7500 Consolette supports the ACIM interface on each model; ordering of the L146 option is no longer required.
Does the APX 7500 Consolette support Tone Remote Control?	The APX 7500 Consolette supports Tone Remote Control on each model; ordering of the L146 option is no longer required.
Can the APX 7500 Consolette support FSK keying?	FSK signaling can be sent to the APX Consolette for over the air transmission when configured for a Flat Audio channel; however, the length of transmission time is controlled by the external equipment. In some cases, the external equipment does not assert the PTT long enough for the transmission to propagate through the APX 7500 Consolette system. Due to the varying nature of these external devices, the APX 7500 Consolette is not certified to support them.

Question	Answer
Does the APX 7500 Consolette support a COR output?	The APX 7500 Consolette supports a relay that is closed when the Consolette receives qualified audio. This relay can be used to switch in a DC voltage specified by the user. For example, when the balanced Wireline Interface is unmuted to receive audio, the CHAN_ACT_RELAY_OUT on the DB25 on the rear panel will be driven with the signal that is provided on CHAN_ACT_RELAY_IN. This signal passes through a relay on the Consolette. This is especially useful when the customer's setup has a signal with a high voltage or if the customer wants to switch in a ground signal. The relay circuitry has a maximum load voltage of 350V and a maximum load current of 120 mA.
Does the APX 7500 Consolette support E&M control?	Yes; the APX 7500 Consolette supports a balanced wireline input and a single-ended TX audio input, either of which can be used in conjunction with a hardware PTT input. Additionally the Consolette provides a relay that closes when there is receive activity. Note that this relay only closes when there is valid qualified audio being received; it does not close based on true COR output behavior which is active anytime there is any RF activity on that receive frequency.
How many channels does the APX 7500 Consolette support?	The user can select up to 16 channels via the TRC interface, up to 1250 via the O5 control head or MCD 5000, up to 12 with the Gold Series Elite's ACIM interface, and up to 255 with the MCC7500's CCGW/ACIM interface. "Channels" refers to the number of radio transceiver channels that can be accessed.
Are there field kits to convert between a W7 and W9 control head style for the APX 7500 Consolette?	The APX 7500 Consolette does not support either the W7 or the W9 control head styles any longer; instead it supports the newer O5 control head. In the past, customers needed to convert between the W7 model to the W9 model in order to correctly configure their Consolette for the appropriate remote control method. This is no longer needed as the APX 7500 Consolette is designed to support all rear panel functionality regardless of the front panel configuration (blank versus full feature model).
Does the blank panel configuration of the APX 7500 Consolette support Tone Remote Control?	Yes, the APX 7500 Consolette supports Tone Remote Control on both the blank panel configuration and the full feature configuration.
Can the PLN1360 and PLN1687 tone remote controller cards be reused in the APX 7500 Consolette?	No. The APX 7500 Consolette is a complete redesign – there is no reuse from previous Consolette designs.
Can the APX 7500 Consolette be used over the Internet?	The Consolette can be configured remotely over an IP connection. Remote control from the MCD 5000 via an IP interface is also supported.
Does the APX 7500 Consolette support the MCD 5000?	Yes, the APX 7500 Consolette supports the MCD 5000 via its LAN interface.

Question	Answer
Does the full-feature front panel configuration of the APX 7500 Consolette support attachment of the MCD 5000 Deskset?	Yes, both the full feature and blank front configurations support the MCD 5000 Deskset. All O5 control head features remain available when the full feature Consolette is used with the MCD 5000.
Can the APX 7500 Consolette decode an Emergency Alarm?	The APX 7500 Consolette can decode Emergency Alarms. Emergency Alarms are typically generated by a subscriber when the user presses the orange button. This alarm is sent over the air to the Consolette. The Consolette can decode this and if configured can report it to the console via the ACIM interface, generate a display message on the O5 control head, an alert tone, and also assert a VIP output. Supported signaling types include: MDC, ASTRO Conventional, Type II Trunking (both analog and digital talkgroups) and APCO P25 Trunking. Note that on trunking systems, the Consolette can only decode Emergency alarms while on the control channel. This means that once the Consolette is on a voice channel, it cannot receive the control channel any longer and may miss emergency alarms. The Consolette will move from the control channel to the voice channel during trunking voice calls. The SCAN feature may also cause the Consolette to miss Emergency Alarms.
Can the APX 7500 Consolette be used with the MC 2000 Tone Remote Control Deskset?	Yes. Up to 10 MC2000s can be connected in parallel.
Can the APX 7500 Consolette be used with DGT 9000s/RCH 3000s/MC 3000s/MIP 5000s?	No. The APX 7500 Consolette supports the MCD 5000 Deskset. The APX 7500 Consolette does not support remote controlhead style desksets such as the DGT 9000, RCH 3000, MC 3000, and MIP 5000. Note: There are other configurations of the MIP 5000 that are supported such as the TRC configuration and the E&M configuration.
Are VIP Outs available on the APX 7500 Consolette and if so, what are they used for?	There are 3 VIP Outs available on the rear panel of the Consolette. The connector style is a 14-pin terminal connector and each Consolette ships with a mating connector. These outputs can be configured to activate for a variety of things but the most popular for Consolette users are: <ol style="list-style-type: none"> 1. To activate in the event of decoding an Emergency Alarm. 2. To activate in the event of user's button press on the front panel (ex. Aux Control). 3. To activate in the event of going into Failsoft or Wide Area or Site Trunking.
Are VIP Outs only available on models with the O5 control head present?	The VIP Outs are now supported on the rear panel of the Consolette on all models – both the model with the O5 control head and the model without the O5 control head. To activate in the event of an incoming Call Alert / Page, Selective / Private Call, Phone Call, or Message (i.e. Horn and Lights Alarm feature).
Are Headsets supported on the APX 7500 Consolette?	Yes. There are connections provided on the rear panel for two headsets. These connections are designed for the Headset Jackbox FHN7470_ and the corresponding Headset Base with PTT CDN6281. Various Plantronics headsets are supported – refer to the price pages for more information.

Question	Answer
Is there special software required to access the codeplug programming of the APX 7500 Consolette?	APX family CPS is required to program the radio transceiver parameters of the APX 7500 Consolette. This must be purchased – see ECAT/Price Pages for more details. The APX 7500 Consolette also supports an onboard web server for configuration of Consolette specific settings such as the wireline (ex. 2-wire versus 4-wire). In the past, these settings were made with onboard dipswitches. These have been designed out in the APX 7500 Consolette. To access these settings from a laptop, the user must have an web browser such as Internet Explorer. No additional application software is needed.
Does the APX 7500 Consolette support aliasing?	There can be multiple end user points in the APX Consolette system where IDs and/or aliases can be viewed, including the O5 control head and remote console GUI (various). O5 Display: The radio transceiver can be programmed via CPS to display either the numeric ID or the alias on the O5 control head. Console Display: The ID is provided by the Consolette to the Console via the ACIM/RS232 interface in numeric format. The conversion to its alias is done at the console if it supports this functionality. For example, the MCC5500 can convert the numeric ID to its alias but requires the alias database option. Refer to the specifications of your connected console for details on its capabilities in this area.
Does the APX 7500 Consolette support an output for a recorder?	Yes. The recorder is on a dedicated RJ45 connector and can be configured to provide either a.) receive audio including tones or b.) receive audio including tones and including transmit audio. A logic signal is provided on this same connector to indicate when there is activity on this connector.
Can the APX 7500 Consolette provide received over-the-air MDC-1200 tones on its receive audio path for external decoding?	Yes. The APX 7500 Consolette can be configured to provide the MDC-1200 tones on its receive audio path. The radio transceiver must be programmed with an MDC System and properly configured to unmute during the MDC-1200 data burst. If an external decoder is used in the system, it is recommended that MDC ID decode be disabled on the ACIM path in order to prevent multiple reportings of the same ID to the Console user.
Where can I find training for the APX 7500 Consolette?	Specific training for the Consolette is not available; however, training is available for the APX 7500 and CPS. To access go to: https://techtrain.motorola.com
Where can I get additional information about the APX 7500 Consolette?	Refer to ECATs/Price Pages for the latest production information. Additionally refer to the Detailed Service Manual, 68009482001, available online at https://businessonline.motorola.com

APPENDIX A REPLACEMENT PARTS ORDERING

A.1 Basic Ordering Information

When ordering replacement parts or equipment information, the complete identification number should be included. This applies to all components, kits, and chassis. If the component part number is not known, the order should include the number of the chassis or kit of which it is a part, and sufficient description of the desired component to identify it.

A.2 Motorola Online

Motorola Online users can access our online catalog at

<http://www.motorola.com/businessonline>

To register for online access, please call 1-800-422-4210 (for U.S. and Canada Service Centers only). International customers can obtain assistance at <http://www.motorola.com/businessonline>

A.3 Mail Orders

Mail orders are only accepted by the U.S. Federal Government Markets Division (USFGMD):

Motorola Inc.
7031 Columbia Gateway Drive
3rd Floor - Order Processing
Columbia, MD 21046
U.S.A.

A.4 Telephone Orders

Radio Products and Solutions Organization*
(United States and Canada)
7:00 AM to 7:00 PM (Central Standard Time)
Monday through Friday (Chicago, U.S.A.)
1-800-422-4210
1-847-538-8023 (United States and Canada)

U.S. Federal Government Markets Division (USFGMD)
1-877-873-4668
8:30 AM to 5:00 PM (Eastern Standard Time)

A.5 Fax Orders

Radio Products and Solutions Organization*
(United States and Canada)
1-800-622-6210
1-847-576-3023 (International)

USFGMD
(Federal Government Orders)
1-800-526-8641 (For Parts and Equipment Purchase Orders)

A.6 Parts Identification

Radio Products and Solutions Organization*
(United States and Canada)
1-800-422-4210

A.7 Product Customer Service

After collecting the required information and writing a detailed problem report, contact one of the following support centers to help with the problem:

- Motorola System Support Center (SSC)

A.8 Motorola System Support Center (SSC)

The Motorola System Support Center (SSC) is the primary Motorola contact. Call Motorola System Support Center (SSC):

- Prior to any software reload.
- To confirm troubleshooting results and analysis prior to removing and replacing a Field Replaceable Unit (FRU) or Field Replaceable Equipment (FRE) to repair the system.

Motorola System Support Center (SSC):

Phone: (800) 221-7144 for domestic calls and (847) 576-7300 for international calls

Fax: (847) 725-4073



Motorola Solutions, Inc.
1303 East Algonquin Road
Schaumburg, Illinois 60196 U.S.A.

MOTOROLA, MOTO, MOTOROLA SOLUTIONS and
the Stylized M logo are trademarks or registered trademarks
of Motorola Trademark Holdings, LLC and are used under license.
All other trademarks are the property of their respective owners.
© 2012 Motorola Solutions, Inc. All rights reserved.
October 2012.



68009483001-D